

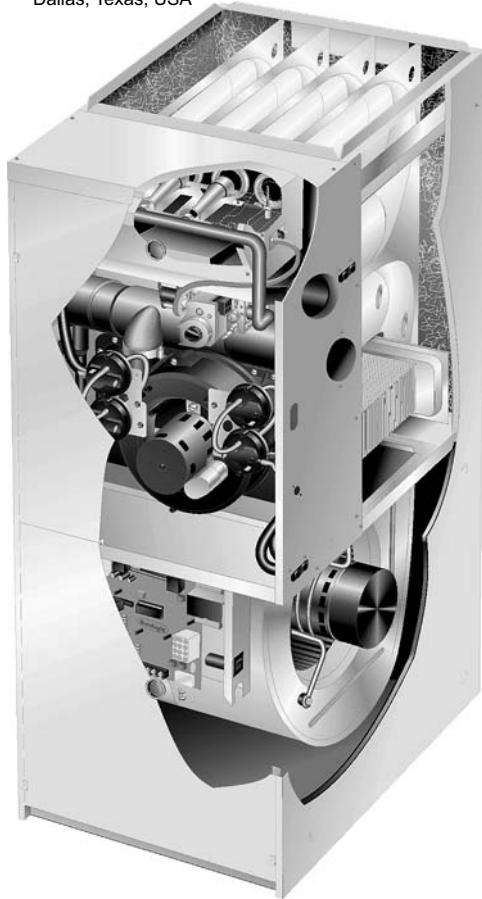

© 2011 Lennox Industries Inc.
Dallas, Texas, USA



THIS MANUAL MUST BE LEFT WITH THE HOMEOWNER FOR FUTURE REFERENCE

INSTALLATION INSTRUCTIONS

G61MPV SERIES UNITS

GAS UNITS
506506-01
01/2011
Supersedes 07/2010

TP Technical Publications
Litho U.S.A.

Table of Contents

Unit Dimensions	2
G61MPV Parts Arrangement	3
Shipping and Packing List	4
Safety Information	4
Use of Furnace as Construction Heater	5
General	6
Combustion, Dilution & Ventilation Air	6
Installation - Setting Equipment	9
Filters	15
Duct System	16
Pipe & Fittings Specifications	16
Vent Piping Guidelines	19
Joint Cementing Procedure	20
Venting Practices	21
Gas Piping	36
Electrical	38
Integrated Control Board	45
Unit Start-Up	55
Gas Pressure Adjustment	56
High Altitude Information	57
Other Unit Adjustments	59
Service	60
Ignition Control Board Diagnostic Codes	63
Troubleshooting	64
Repair Parts List	69
Vent Pipe Sizing Worksheet	70
Start-Up & Performance Check List	71



⚠ WARNING

FIRE OR EXPLOSION HAZARD.

Failure to follow safety warnings exactly could result in serious injury, death, or property damage.



Do not store or use gasoline or other flammable vapors and liquids in the vicinity of this or any other appliance.

Installation and service must be performed by a qualified installer, service agency or the gas supplier.

WHAT TO DO IF YOU SMELL GAS:

- **Do not try to light any appliance.**
- **Do not touch any electrical switch; do not use any phone in your building.**
- **Leave the building immediately.**
- **Immediately call your gas supplier from a neighbor's phone. Follow the gas supplier's instructions.**
- **If you cannot reach your gas supplier, call the fire department.**



G61MPV Unit Dimensions - inches (mm)

*60C and 60D size units installed in upflow applications that require air volumes over 1800 cfm (850 L/s) must have one of the following:

1. Single side return air with transition, to accommodate 20 x 25 x 1 in. (508 x 635 x 25 mm) air filter. Required to maintain proper air velocity.
2. Single side return air with optional RAB Return Air Base
3. Bottom return air.
4. Return air from both sides.
5. Bottom and one side return air.

Refer to Engineering Handbook for additional information.

****Consider sizing requirements for optional IAQ equipment before cutting side return opening.**

¹ Optional External Side Return Air Filter Kit is not for use with the optional RAB Return Air Base.

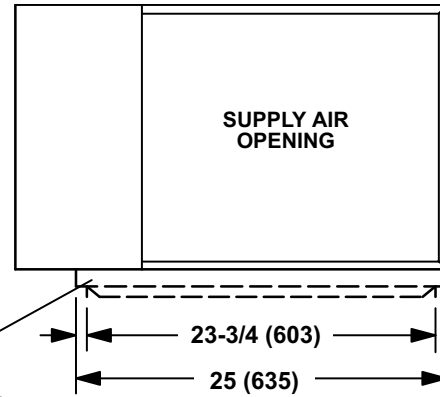

¹OPTIONAL EXTERNAL SIDE RETURN AIR FILTER KIT (Either Side)

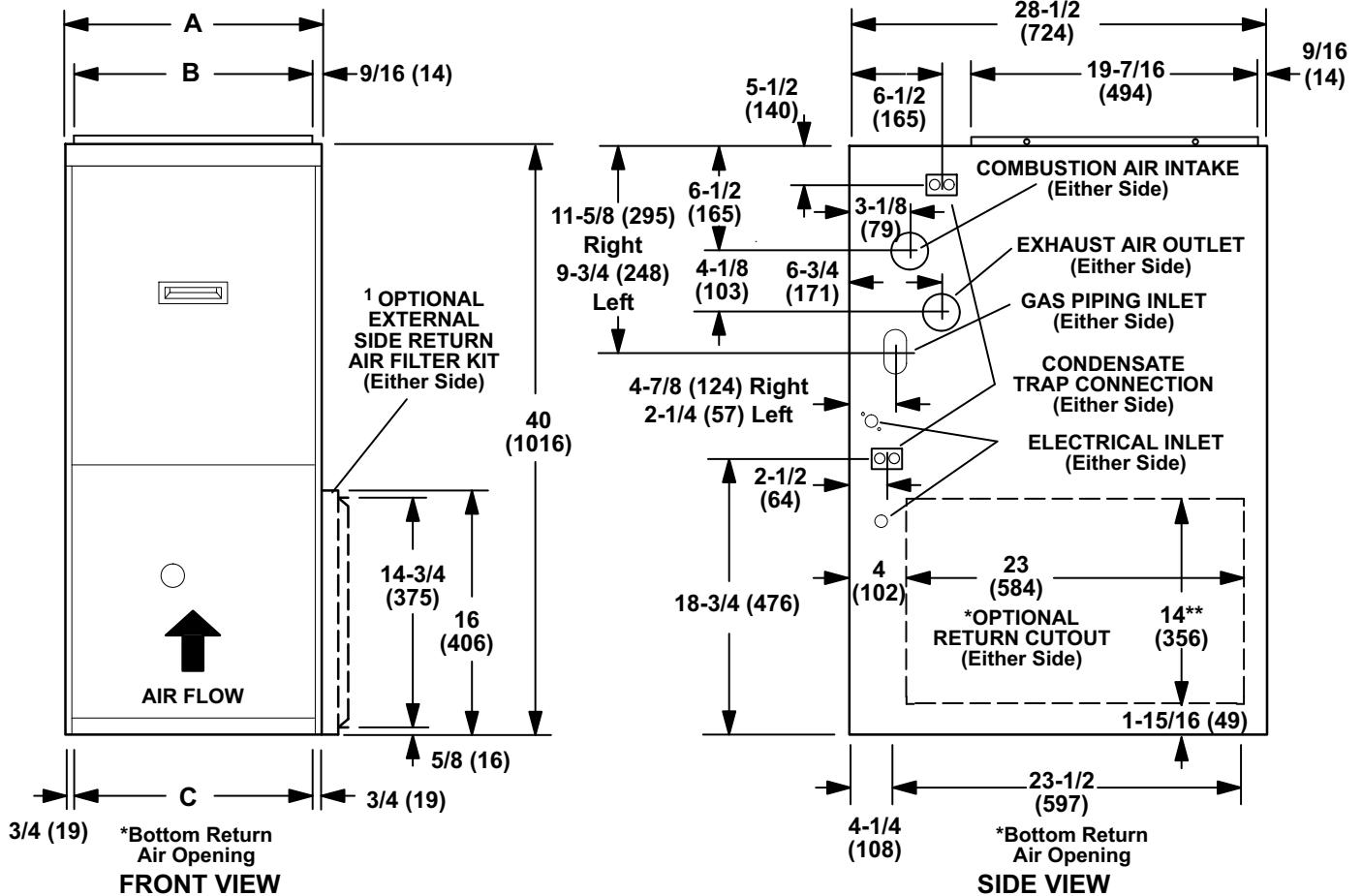

Model No.	A		B		C	
	in.	mm	in.	mm	in.	mm
G61MPV-36B-045 G61MPV-36B-070 G61MPV-36B-071	17-1/2	446	16-3/8	416	16	406
G61MPV-36C-090 G61MPV-60C-090 G61MPV-60C-091 G61MPV-60C-110 G61MPV-60C-111	21	533	19-7/8	505	19-1/2	495
G61MPV-60D-135	24-1/2	622	23-3/8	546	23	584

G61MPV Parts Arrangement

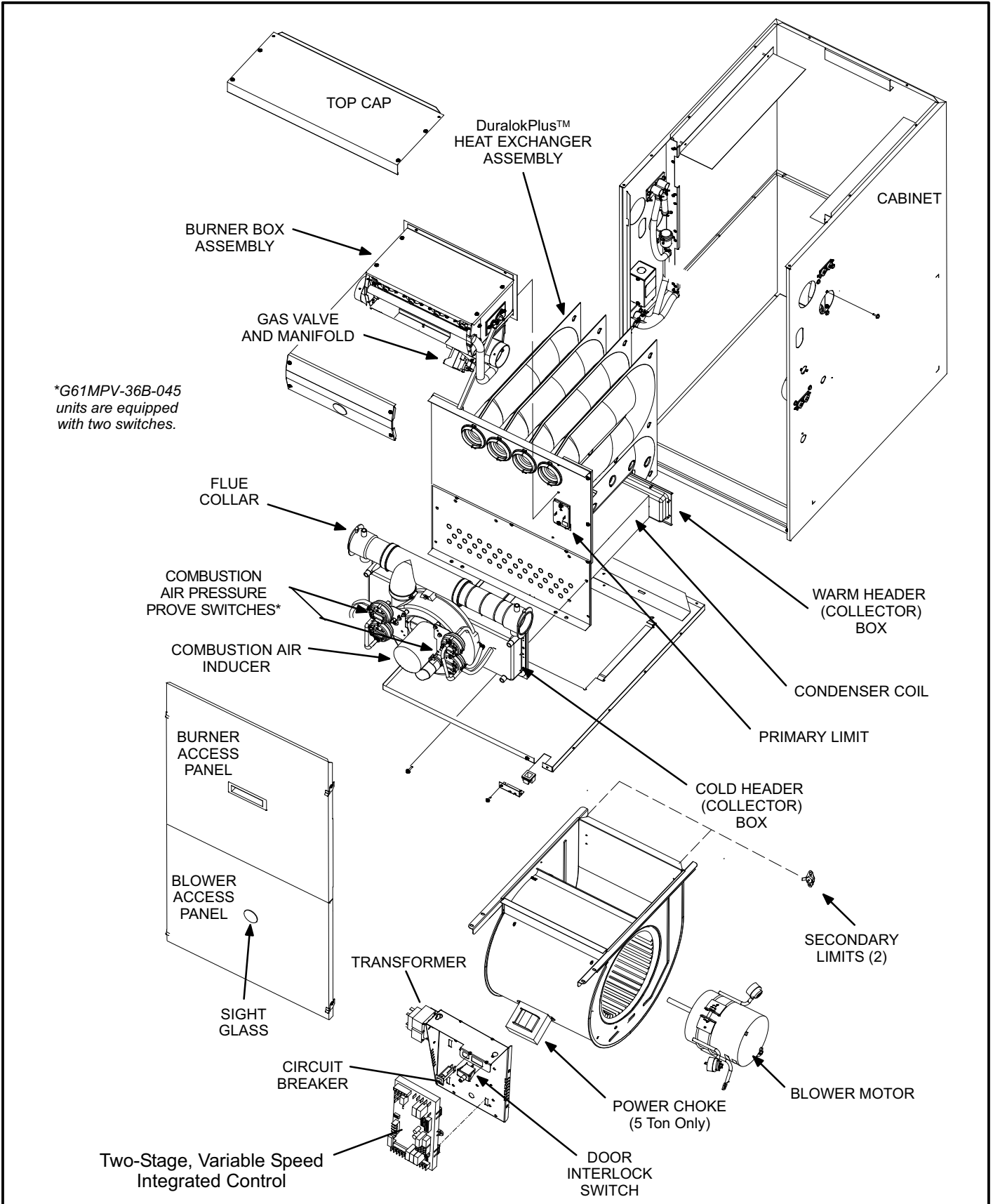

FIGURE 1

G61MPV Gas Furnace

The G61MPV category IV gas furnace is equipped with a two-stage, variable speed integrated control. This control ensures compatibility with Lennox' Harmony III zone control system, as well as a thermostat which provides humidity control. Each G61MPV is shipped ready for installation in the upflow, downflow, horizontal left air discharge or horizontal right air discharge position. The furnace is shipped with the bottom panel in place. The bottom panel must be removed if the unit is to be installed in upflow applications with bottom return air. The bottom panel must also be removed and discarded in all downflow or horizontal applications.

The furnace is equipped for installation in natural gas applications. A conversion kit (ordered separately) is required for use in propane/LP gas applications.

The G61MPV can be installed as either a Direct Vent or a Non-Direct Vent gas central furnace.

NOTE - In Direct Vent installations, combustion air is taken from outdoors and flue gases are discharged outdoors. In Non-Direct Vent installations, combustion air is taken from indoors and flue gases are discharged outdoors. See figure 2 for applications involving roof termination.

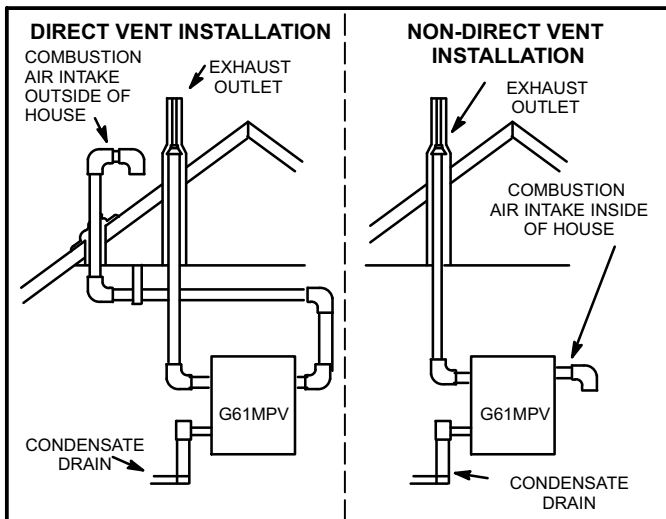

FIGURE 2

Shipping and Packing List

Package 1 of 1 contains

- 1 - Assembled G61MPV unit
- 1 - Bag assembly containing the following:
 - 3 - Screws
 - 3 - Wire nuts
 - 1 - Snap bushing
 - 1 - Snap plug
 - 1 - Wire tie
 - 1 - Condensate trap
 - 1 - Condensate trap cap
 - 2 - 2" diameter vent / intake plugs

- 1 - 3" diameter cabinet plug (intake)
- 1 - 2" diameter debris screen
- 1 - Logo sticker (for use in downflow applications)

NOTE - G61MPV-60C-110 and G61MPV-60C-111 units also include a 2" diameter PVC street elbow, which is shipped on the blower deck in the heating compartment. G61MPV-60D-135 units are shipped with a 3" to 2" PVC reducing elbow.

Canadian Installations Only - Replace the provided 2" street elbow shipped with the G61MPV-60C-110 and G61MPV-60C-111 units with 2" street elbow Y0162. Replace the provided 3" X 2" reducing elbow shipped with the G61MPV-60D-135 units with 3" X 2" reducing elbow 40W22. Y0162 and 40W22 meet B149 vent requirements.

The following items may also be ordered separately:

- 1 - Thermostat
- 1 - Propane/LP changeover kit

⚠ DANGER

Danger of explosion.

There are circumstances in which odorant used with LP/propane gas can lose its scent. In case of a leak, LP/propane gas will settle close to the floor and may be difficult to smell. An LP/propane leak detector should be installed in all LP applications.

Check equipment for shipping damage. If you find any damage, immediately contact the last carrier.

Safety Information

⚠ WARNING

Improper installation, adjustment, alteration, service or maintenance can cause property damage, personal injury or loss of life. Installation and service must be performed by a licensed professional installer (or equivalent), service agency or the gas supplier.

⚠ CAUTION

As with any mechanical equipment, personal injury can result from contact with sharp sheet metal edges. Be careful when you handle this equipment.

Use only the type of gas approved for use with this furnace. Refer to unit nameplate.

G61MPV units are CSA International certified to ANSI Z21.47 and CSA 2.3 standards.

In the USA, installation of gas furnaces must conform with local building codes. In the absence of local codes, units must be installed according to the current National Fuel Gas Code (ANSI-Z223.1/NFPA 54). The National Fuel Gas Code is available from the following address:

American National Standards Institute, Inc.
11 West 42nd Street
New York, NY 10036

In Canada, installation must conform with current National Standard of Canada CSA-B149 Natural Gas and Propane Installation Codes, local plumbing or waste water codes and other applicable local codes.

In order to ensure proper unit operation in non-direct vent applications, combustion and ventilation air supply must be provided according to the current National Fuel Gas Code or CSA-B149 standard.

This furnace is CSA International certified for installation clearances to combustibles as listed on the unit nameplate and in the tables in figures 8, 13 and 17. Accessibility and service clearances must take precedence over fire protection clearances.

NOTE - For installation on combustible floors, the furnace shall not be installed directly on carpeting, tile, or other combustible material other than wood flooring.

For installation in a residential garage, the furnace must be installed so that the burner(s) and the ignition source are located no less than 18 inches (457 mm) above the floor. The furnace must be located or protected to avoid physical damage by vehicles. When a furnace is installed in a public garage, hangar, or other building that has a hazardous atmosphere, the furnace must be installed according to recommended good practice requirements and current National Fuel Gas Code or CSA B149 standard.

NOTE - Furnace must be adjusted to obtain a temperature rise within the range specified on the unit nameplate. Failure to do so may cause erratic limit operation.

This G61MPV furnace may be used as a high-static unit heater. The G61MPV may also be installed in an aircraft hangar in accordance with the Standard for Aircraft Hangars (ANSI/NFPA No. 408-1990).

Installation in parking structures must be in accordance with the Standard for Parking Structures (ANSI/NFPA No. 88A-1991). Installation in repair garages must be in accordance with the Standard for Repair Garages (ANSI/NFPA No. 88B-1991).

This G61MPV furnace must be installed so that its electrical components are protected from water.

When this furnace is used with cooling units, it shall be installed in parallel with, or on the upstream side of, cooling units to avoid condensation in the heating compartment. With a parallel flow arrangement, a damper (or other means to control the flow of air) must adequately prevent chilled air

from entering the furnace. If the damper is manually operated, it must be equipped to prevent operation of either the heating or the cooling unit, unless it is in the full **HEAT** or **COOL** setting.

When installed, this furnace must be electrically grounded according to local codes. In addition, in the United States, installation must conform with the current National Electric Code, ANSI/NFPA No. 70. The National Electric Code (ANSI/NFPA No. 70) is available from the following address:

National Fire Protection Association
1 Battery March Park
Quincy, MA 02269

In Canada, all electrical wiring and grounding for the unit must be installed according to the current regulations of the Canadian Electrical Code Part I (CSA Standard C22.1) and/or local codes.

NOTE - This furnace is designed for a minimum continuous return air temperature of 60°F (16°C) or an intermittent operation down to 55°F (13°C) dry bulb for cases where a night setback thermostat is used. Return air temperature must not exceed 85°F (29°C) dry bulb.

The G61MPV furnace may be installed in alcoves, closets, attics, basements, garages, and utility rooms.

This furnace design has not been CSA certified for installation in mobile homes, recreational vehicles, or outdoors.

Never use an open flame to test for gas leaks. Check all connections using a commercially available soap solution made specifically for leak detection.

Use of Furnace as Construction Heater

Lennox does not recommend the use of G61MPV units as a construction heater during any phase of construction. Very low return air temperatures, harmful vapors and operation of the unit with clogged or misplaced filters will damage the unit.

G61MPV units may be used for heating of buildings or structures under construction, if the following conditions are met:

- *The vent system must be permanently installed per these installation instructions.*
- *A room thermostat must control the furnace. The use of fixed jumpers that will provide continuous heating is not allowed.*
- *The return air duct must be provided and sealed to the furnace.*
- *Return air temperature range between 60°F (16°C) and 80°F (27°C) must be maintained.*
- *Air filters must be installed in the system and must be maintained during construction.*
- *Air filters must be replaced upon construction completion.*

- The input rate and temperature rise must be set per the furnace rating plate.
- One hundred percent (100%) outdoor air must be provided for combustion air requirements during construction. Temporary ducting may supply outdoor air to the furnace. Do not connect duct directly to the furnace. Size the temporary duct following these instructions in section for Combustion, Dilution and Ventilation Air in a confined space with air from outside.
- The furnace heat exchanger, components, duct system, air filters and evaporator coils must be thoroughly cleaned following final construction clean-up.
- All furnace operating conditions (including ignition, input rate, temperature rise and venting) must be verified according to these installation instructions.

General

These instructions are intended as a general guide and do not supersede local codes in any way. Consult authorities having jurisdiction before installation.

In addition to the requirements outlined previously, the following general recommendations must be considered when installing a G61MPV furnace:

- Place the furnace as close to the center of the air distribution system as possible. The furnace should also be located close to the chimney or vent termination point.
- When the furnace is installed in non-direct vent applications, do not install the furnace where drafts might blow directly into it. This could cause improper combustion and unsafe operation.
- When the furnace is installed in non-direct vent applications, do not block the furnace combustion air opening with clothing, boxes, doors, etc. Air is needed for proper combustion and safe unit operation.
- When the furnace is installed in an attic or other insulated space, keep insulation away from the furnace.
- When the furnace is installed in an unconditioned space, consider provisions required to prevent freezing of condensate drain system.

⚠ CAUTION

G61MPV unit should not be installed in areas normally subject to freezing temperatures.

⚠ WARNING

Product contains fiberglass wool.

Disturbing the insulation in this product during installation, maintenance, or repair will expose you to fiberglass wool. Breathing this may cause lung cancer. (Fiberglass wool is known to the State of California to cause cancer.)

Fiberglass wool may also cause respiratory, skin, and eye irritation.

To reduce exposure to this substance or for further information, consult material safety data sheets available from address shown below, or contact your supervisor.

**Lennox Industries Inc.
P.O. Box 799900
Dallas, TX 75379-9900**

Combustion, Dilution & Ventilation Air

If the G61MPV is installed as a Non-Direct Vent Furnace, follow the guidelines in this section.

NOTE - In Non-Direct Vent installations, combustion air is taken from indoors and flue gases are discharged outdoors.

⚠ WARNING

Insufficient combustion air can cause headaches, nausea, dizziness or asphyxiation. It will also cause excess water in the heat exchanger resulting in rusting and premature heat exchanger failure. Excessive exposure to contaminated combustion air will result in safety and performance related problems. Avoid exposure to the following substances in the combustion air supply:

**Permanent wave solutions
Chlorinated waxes and cleaners
Chlorine base swimming pool chemicals
Water softening chemicals
De-icing salts or chemicals
Carbon tetrachloride
Halogen type refrigerants
Cleaning solvents (such as perchloroethylene)
Printing inks, paint removers, varnishes, etc.
Hydrochloric acid
Cements and glues
Antistatic fabric softeners for clothes dryers
Masonry acid washing materials**

In the past, there was no problem in bringing in sufficient outdoor air for combustion. Infiltration provided all the air that was needed. In today's homes, tight construction practices make it necessary to bring in air from outside for combustion. Take into account that exhaust fans, appliance vents, chimneys, and fireplaces force additional

air that could be used for combustion out of the house. Unless outside air is brought into the house for combustion, negative pressure (outside pressure is greater than inside pressure) will build to the point that a downdraft can occur in the furnace vent pipe or chimney. As a result, combustion gases enter the living space creating a potentially dangerous situation.

In the absence of local codes concerning air for combustion and ventilation, use the guidelines and procedures in this section to install G61MPV furnaces to ensure efficient and safe operation. You must consider combustion air needs and requirements for exhaust vents and gas piping. A portion of this information has been reprinted with permission from the National Fuel Gas Code (ANSI-Z223.1/NFPA 54). This reprinted material is not the complete and official position of the ANSI on the referenced subject, which is represented only by the standard in its entirety.

In Canada, refer to the standard CSA B149 installation codes.

▲ CAUTION

Do not install the furnace in a corrosive or contaminated atmosphere. Meet all combustion and ventilation air requirements, as well as all local codes.

All gas-fired appliances require air for the combustion process. If sufficient combustion air is not available, the furnace or other appliance will operate inefficiently and unsafely. Enough air must be provided to meet the needs of all fuel-burning appliances and appliances such as exhaust fans which force air out of the house. When fireplaces, exhaust fans, or clothes dryers are used at the same time as the furnace, much more air is required to ensure proper combustion and to prevent a downdraft. Insufficient air causes incomplete combustion which can result in carbon monoxide.

In addition to providing combustion air, fresh outdoor air dilutes contaminants in the indoor air. These contaminants may include bleaches, adhesives, detergents, solvents and other contaminants which can corrode furnace components.

The requirements for providing air for combustion and ventilation depend largely on whether the furnace is installed in an unconfined or a confined space.

Unconfined Space

An unconfined space is an area such as a basement or large equipment room with a volume greater than 50 cubic feet (1.42 m³) per 1,000 Btu (.29 kW) per hour of the combined input rating of all appliances installed in that space. This space also includes adjacent rooms which are not

separated by a door. Though an area may appear to be unconfined, it might be necessary to bring in outdoor air for combustion if the structure does not provide enough air by infiltration. If the furnace is located in a building of tight construction with weather stripping and caulking around the windows and doors, follow the procedures in the air from outside section.

Confined Space

A confined space is an area with a volume less than 50 cubic feet (1.42 m³) per 1,000 Btu (.29 kW) per hour of the combined input rating of all appliances installed in that space. This definition includes furnace closets or small equipment rooms. When the furnace is installed so that supply ducts carry air circulated by the furnace to areas outside the space containing the furnace, the return air **must be** handled by ducts which are sealed to the furnace casing and which terminate outside the space containing the furnace. This is especially important when the furnace is mounted on a platform in a confined space such as a closet or small equipment room. Even a small leak around the base of the unit at the platform or at the return air duct connection can cause a potentially dangerous negative pressure condition. Air for combustion and ventilation can be brought into the confined space either from inside the building or from outside.

Air from Inside

If the confined space that houses the furnace adjoins a space categorized as unconfined, air can be brought in by providing two permanent openings between the two spaces. Each opening must have a minimum free area of 1 square inch (645 mm²) per 1,000 Btu (.29 kW) per hour of total input rating of all gas-fired equipment in the confined space. Each opening must be at least 100 square inches (64516 mm²). One opening shall be within 12 inches (305 mm) of the top of the enclosure and one opening within 12 inches (305 mm) of the bottom. See figure 3.

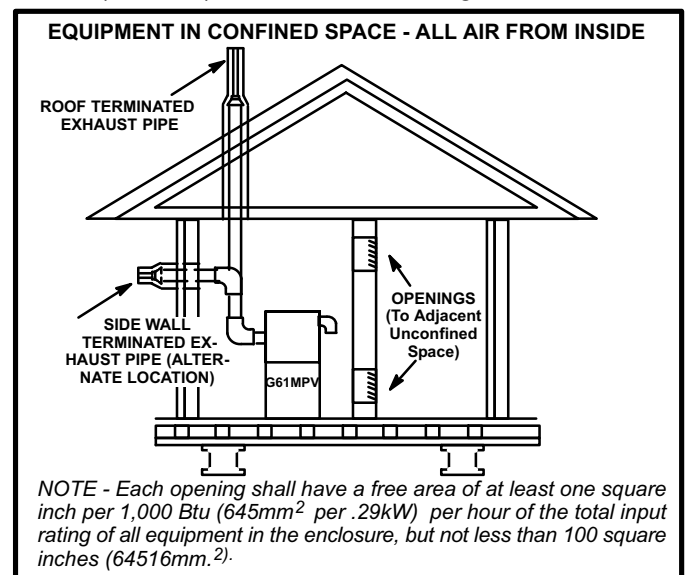

FIGURE 3

Air from Outside

If air from outside is brought in for combustion and ventilation, the confined space shall be provided with two permanent openings. One opening shall be within 12" (305mm) of the top of the enclosure and one within 12" (305mm) of the bottom. These openings must communicate directly or by ducts with the outdoors or spaces (crawl or attic) that freely communicate with the outdoors or indirectly through vertical ducts. Each opening shall have a minimum free area of 1 square inch per 4,000 Btu (645mm² per 1.17kW) per hour of total input rating of all equipment in the enclosure. When communicating with the outdoors through horizontal ducts, each opening shall have a minimum free area of 1 square inch per 2,000 Btu (645mm² per .59kW) per total input rating of all equipment in the enclosure (See figure 4).

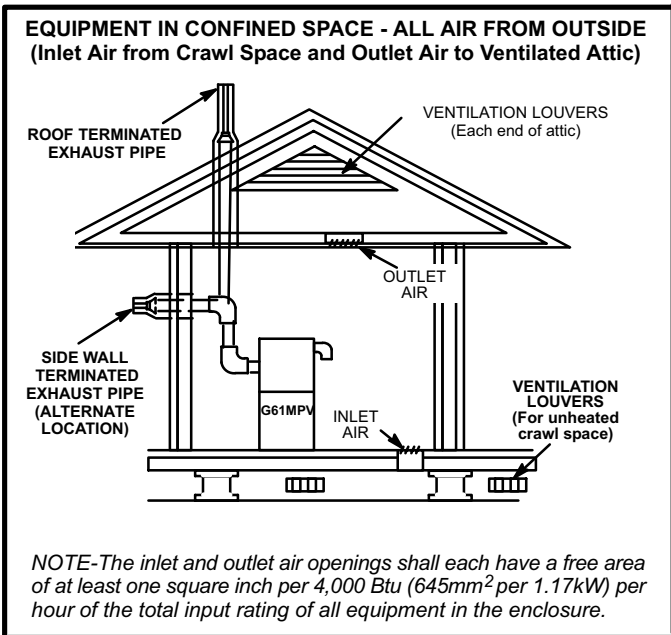

FIGURE 4

If air from outside is brought in for combustion and ventilation, the confined space must have two permanent openings. One opening shall be within 12 inches (305 mm) of the top of the enclosure and one opening within 12 inches (305 mm) of the bottom. These openings must communicate directly or by ducts with the outdoors or spaces (crawl or attic) that freely communicate with the outdoors or indirectly through vertical ducts. Each opening shall have a minimum free area of 1 square inch (645 mm²) per 4,000 Btu (1.17 kW) per hour of total input rating of all equipment in the enclosure. See figures 4 and 5. When communicating with the outdoors through horizontal ducts, each opening shall have a minimum free area of 1 square inch (645 mm²) per 2,000 Btu (.56 kW) per total input rating of all equipment in the enclosure. See figure 6.

When ducts are used, they shall be of the same cross-sectional area as the free area of the openings to which they connect. The minimum dimension of rectangular air ducts shall be no less than 3 inches (75 mm). In calculating free area, the blocking effect of louvers, grilles, or screens must be considered. If the design and free area of protective covering is not known for calculating the size opening required, it may be assumed that wood louvers will have 20 to 25 percent free area and metal louvers and grilles will have 60 to 75 percent free area. Louvers and grilles must be fixed in the open position or interlocked with the equipment so that they are opened automatically during equipment operation.

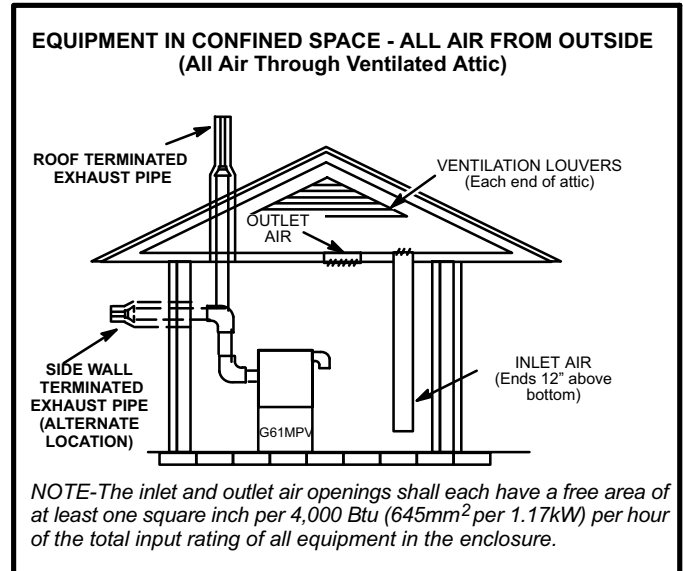

FIGURE 5

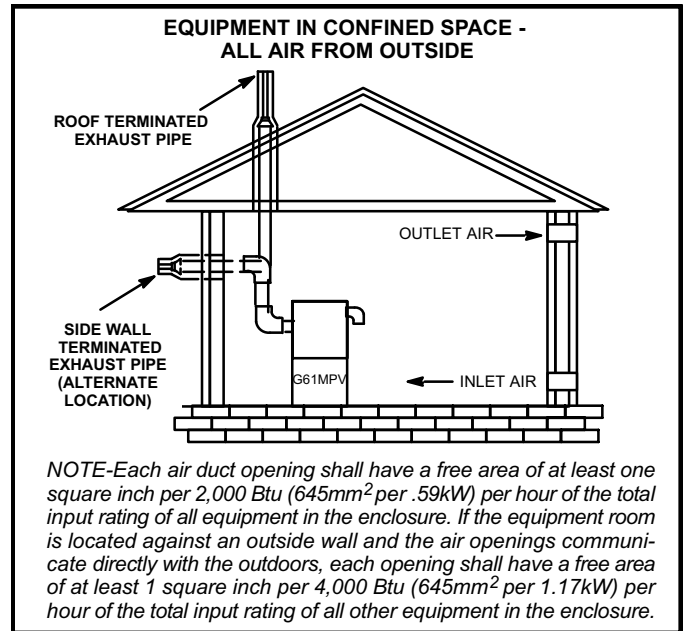

FIGURE 6

Installation - Setting Equipment

⚠ WARNING

Do not install the furnace on its front or its back. Do not connect the return air ducts to the back of the furnace. Doing so will adversely affect the operation of the safety control devices, which could result in personal injury or death.

Select a location that allows for the required clearances that are listed on the unit nameplate. Also consider gas supply connections, electrical supply, vent connection, condensate trap and drain connections, and installation and service clearances [24 inches (610 mm) at unit front]. *The unit must be level from front to back and side to side.*

The unit may be tilted slightly (maximum 1/2 in.) from back to front to aid in the draining of the heat exchanger. See figure 7.

*NOTE - G61MPV-36B and -36C units with 1/2 hp blower motors are equipped with three flexible legs and one rigid leg. The rigid leg is equipped with a shipping bolt and a flat white plastic washer (rather than the rubber mounting grommet used with a flexible mounting leg). **The bolt and washer must be removed before the furnace is placed into operation.** After the bolt and washer have been removed, the rigid leg will not touch the blower housing.*

NOTE - G61MPV-60D-135 units are equipped with a shipping pad under the blower housing. Remove the shipping pad prior to operation.

Allow for clearances to combustible materials as indicated on the unit nameplate. Minimum clearances for closet or alcove installations are shown in figures 8, 13 and 17.

⚠ WARNING

Blower access panel must be securely in place when blower and burners are operating. Gas fumes, which could contain carbon monoxide, can be drawn into living space resulting in personal injury or death.

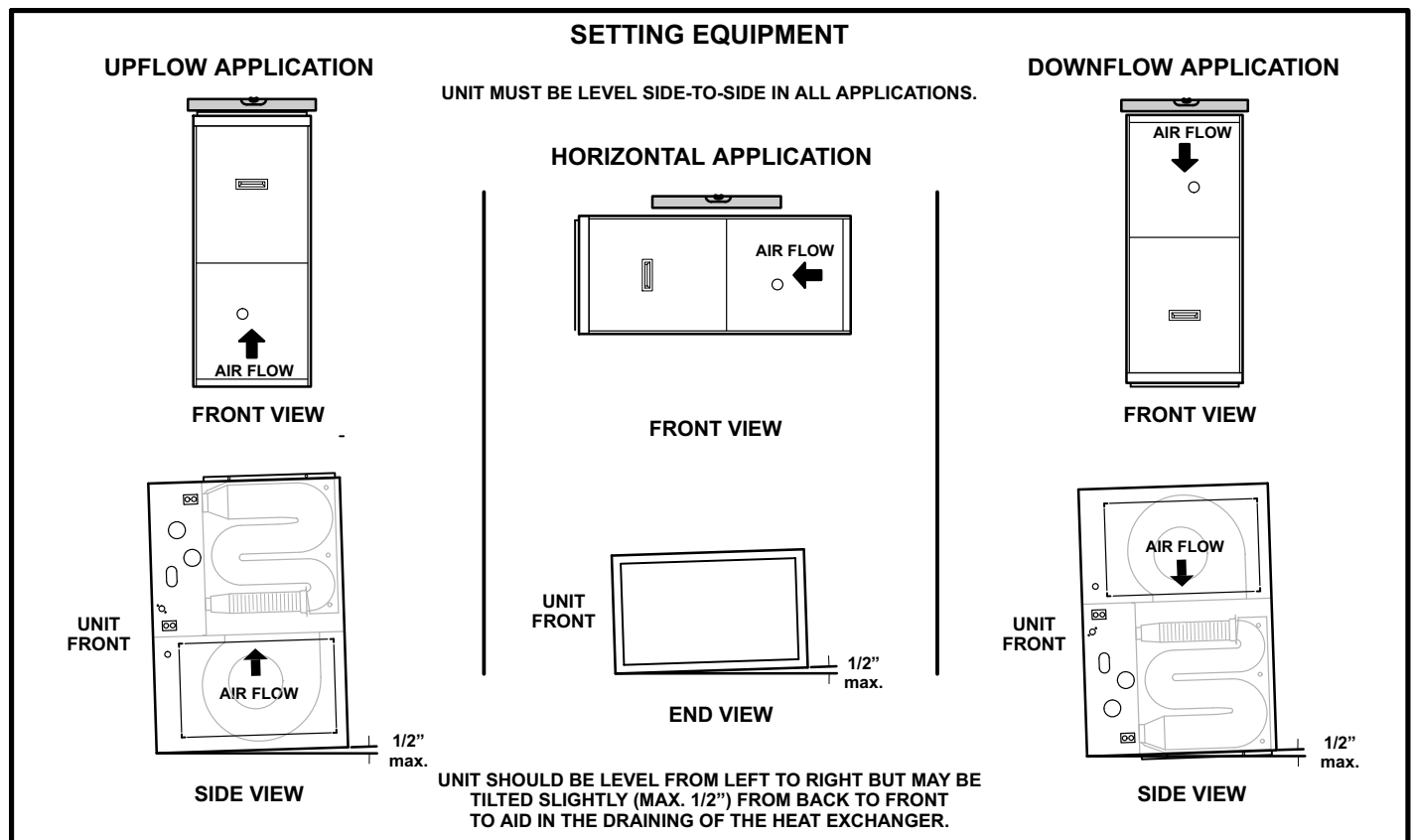

FIGURE 7

⚠ WARNING

Improper installation of the furnace can result in personal injury or death. Combustion and flue products must never be allowed to enter the return air system or air in the living space. Use sheet metal screws and joint tape to seal return air system to furnace. In platform installations with furnace return, the furnace should be sealed airtight to the return air plenum. A door must never be used as a portion of the return air duct system. The base must provide a stable support and an airtight seal to the furnace. Allow absolutely no sagging, cracks, gaps, etc. For no reason should return and supply air duct systems ever be connected to or from other heating devices such as a fireplace or stove, etc. Fire, explosion, carbon monoxide poisoning, personal injury and/or property damage could result.

Upflow Applications

The G61MPV gas furnace can be installed as shipped in the upflow position. Refer to figure 8 for clearances.

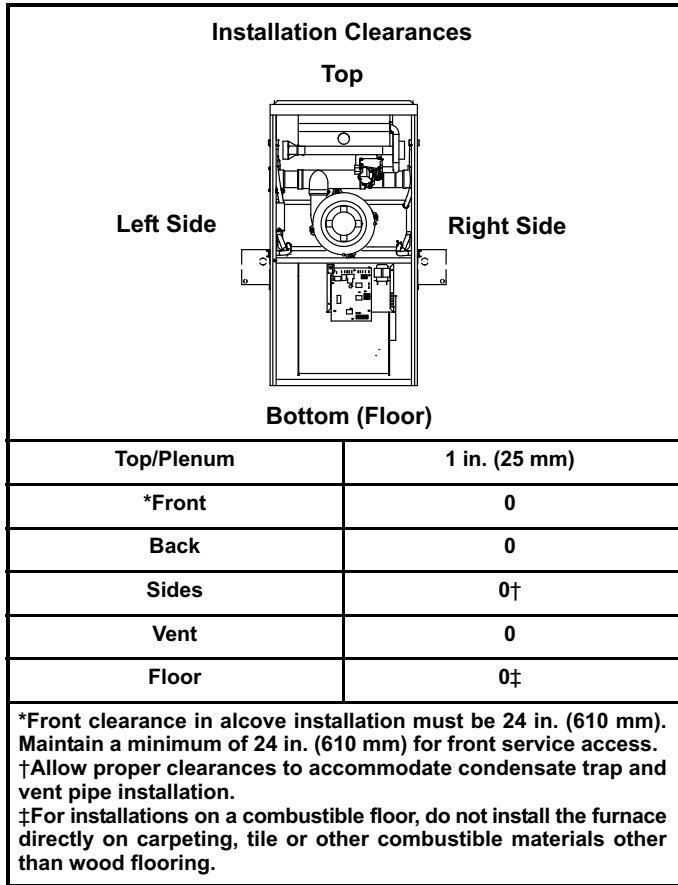

FIGURE 8

Return Air -- Upflow Units

Return air can be brought in through the bottom or either side of the furnace installed in an upflow application. If the furnace is installed on a platform with bottom return, make

an airtight seal between the bottom of the furnace and the platform to ensure that the furnace operates properly and safely. The furnace is equipped with a removable bottom panel to facilitate installation.

Markings are provided on both sides of the furnace cabinet for installations that require side return air. Cut the furnace cabinet at the maximum dimensions shown on page 2.

NOTE - When air volumes over 1800 cfm (850 L/s) are required with 60C or 60D models in an upflow application, the following return air options are available:

- 1 - Return air from single side with transition which will accommodate 20 x 25 x 1 in. (508 x 635 x 25 mm) air filter. (Required to maintain proper air velocity.) See figure 9.
- 2 - Return air from single side with optional RAB Return Air Base. See figure 11.
- 3 - Return air from bottom.
- 4 - Return air from both sides.
- 5 - Return air from bottom and one side.

Refer to Engineering Handbook for additional information.

G61MPV applications which include side return air and a condensate trap installed on the same side of the cabinet require either a return air base or field-fabricated transition to accommodate an optional IAQ accessory taller than 14.5".

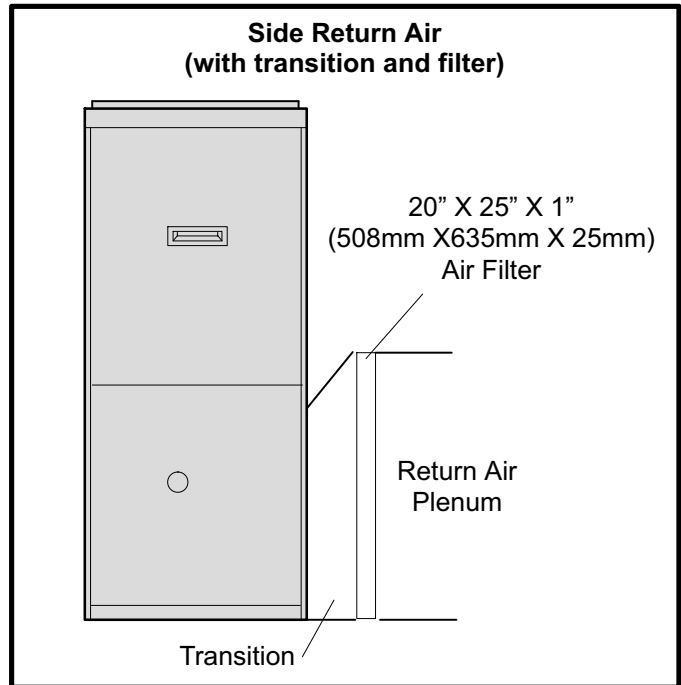

FIGURE 9

Removing the Bottom Panel

Remove the two screws that secure the bottom cap to the furnace. Pivot the bottom cap down to release the bottom panel. Once the bottom panel has been removed, reinstall the bottom cap. See figure 10.

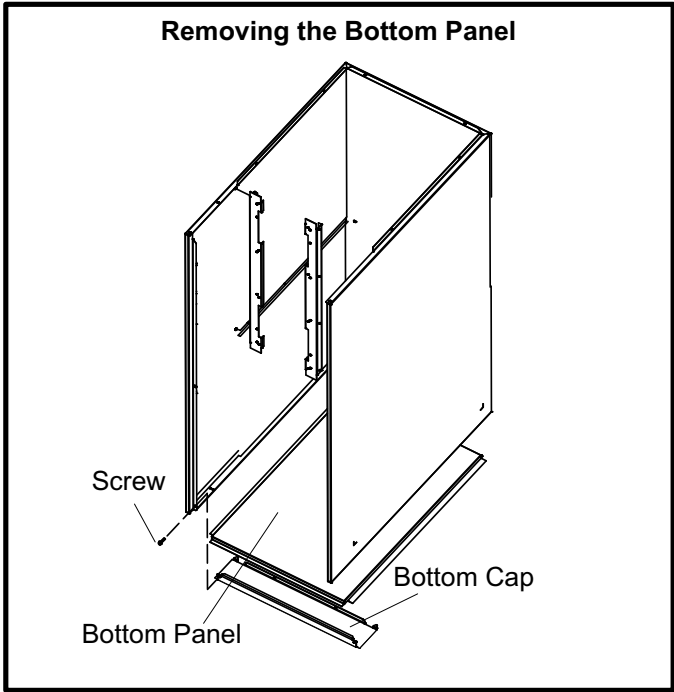

FIGURE 10

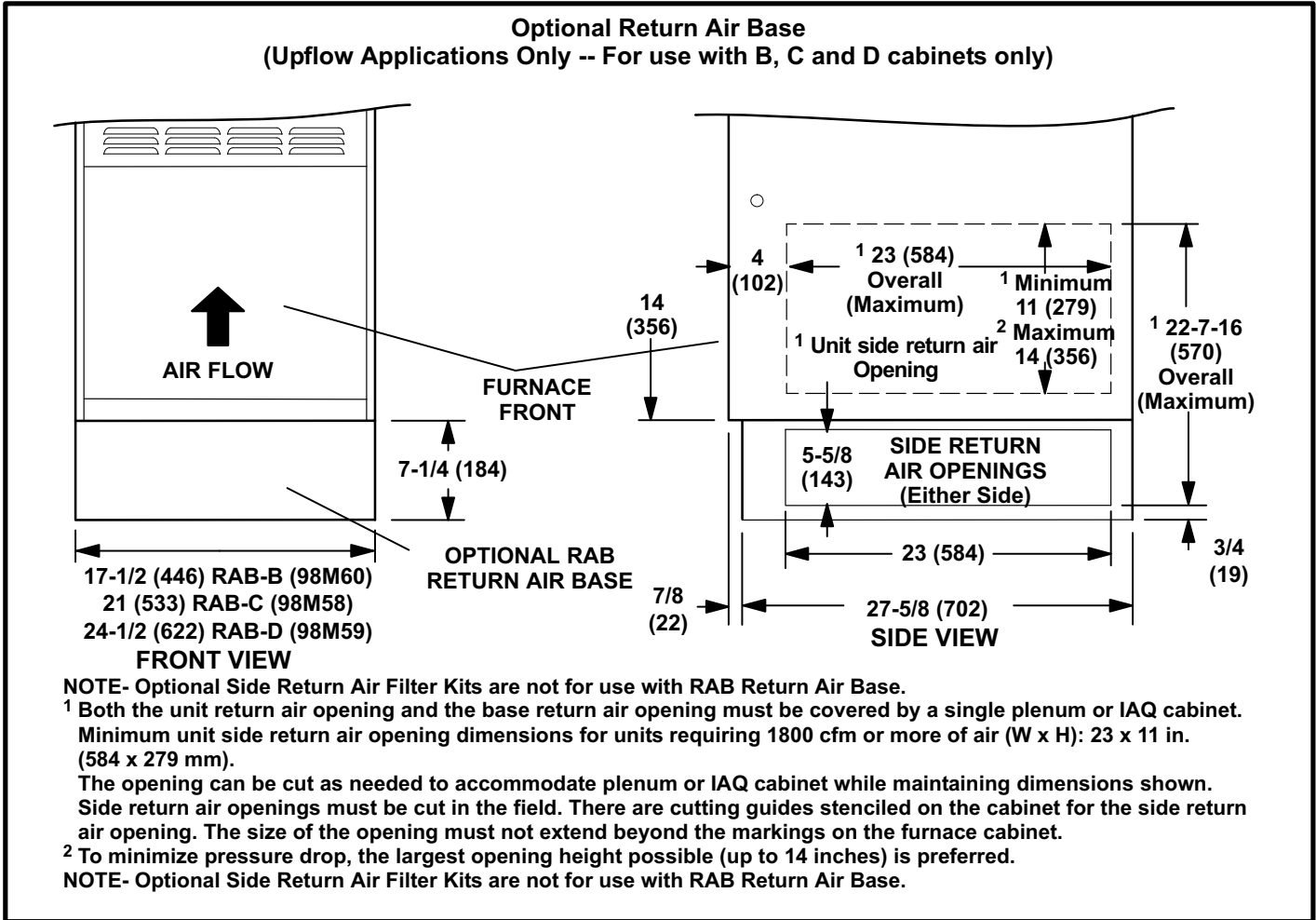

FIGURE 11

Setting an Upflow Unit

When the side return air inlets are used in an upflow application, it may be necessary to install leveling bolts on the bottom of the furnace. Use field-supplied corrosion-resistant 5/16 inch machine bolts (4) and nuts (8). See figure 12.

NOTE - The maximum length of the bolt is 1-1/2 inches.

- 1 - Lie the furnace on its back and drill a 5/16 inch diameter hole in each corner of the furnace's bottom. See figure 12 for the correct location of the holes. Drill through the bottom panel and the bottom flange of the cabinet.
- 2 - Install one bolt and two nuts into each hole. Screw the first nut onto a bolt and then insert the bolt into a hole. A flat washer may be added between the nut and the bottom of the unit.
- 3 - Screw another nut onto the bolt on the inside of the furnace base. A flat washer may be added between the nut and the bottom of the unit.
- 4 - Adjust the outside nut to the appropriate height and tighten the inside nut to secure the arrangement.

NOTE - The unit may be tilted back-to-front a maximum of 1". This will ensure proper draining of the heat exchanger.

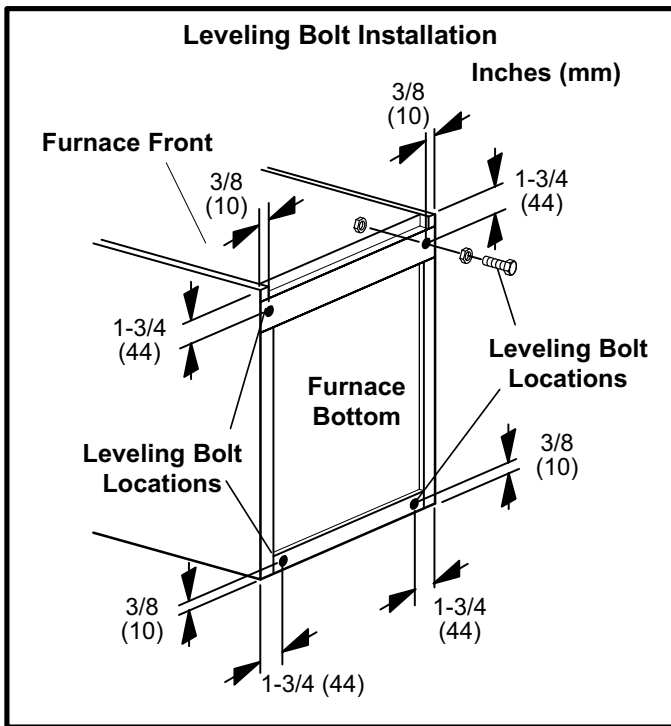

FIGURE 12

Downflow Applications

The unit may be installed three ways in downflow applications: on non-combustible flooring, on combustible flooring using an additive base, or on a reverse-flow cooling cabinet. **Do not drag the unit across the floor in the downflow position. Flange damage will result.**

After unit has been properly set in place, position provided logo over existing logo and affix sticker on front panel.

Refer to figure 13 for clearances in downflow applications.

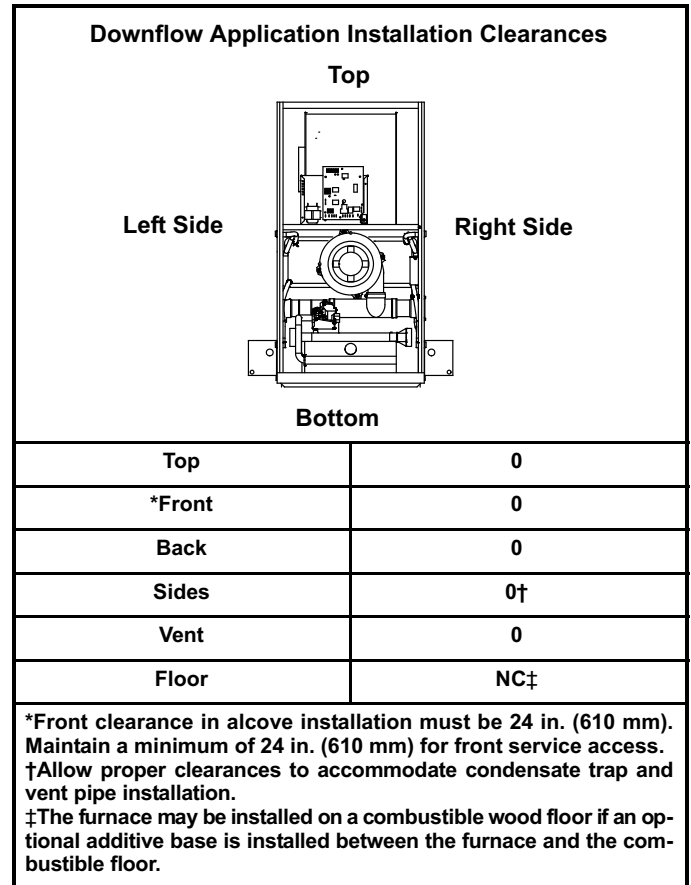

FIGURE 13

Installation on Non-Combustible Flooring

- 1 - Cut floor opening keeping in mind clearances listed on unit rating plate. Also keep in mind gas supply connections, electrical supply, flue and air intake connections and sufficient installation and servicing clearances. See table 1 for correct floor opening size.
- 2 - Flange warm air plenum and lower the plenum into the opening.
- 3 - Set the unit over the plenum and seal the plenum to the unit.
- 4 - Ensure that the seal is adequate.

TABLE 1
NON-COMBUSTIBLE FLOOR OPENING SIZE

Model No.	Front to Rear		Side to Side	
	in.	mm	in.	mm
B Cabinet (17.5")	19 - 3/4	502	16 - 5/8	422
C Cabinet (21")	19 - 3/4	502	20-1/8	511
D Cabinet (24.5")	19 - 3/4	502	23 - 5/8	600

NOTE - Floor opening dimensions listed are 1/4 inch (6 mm) larger than the unit opening. See dimension drawing on page 2.

Installation on Combustible Flooring

- 1 - When unit is installed on a combustible floor, an additive base must be installed between the furnace and the floor. The base must be ordered separately. See table 2 for opening size to cut in floor.

⚠ CAUTION

The furnace and additive base shall not be installed directly on carpeting, tile, or other combustible material other than wood flooring.

**TABLE 2
ADDITIVE BASE FLOOR OPENING SIZE**

Cabinet Width	Catalog Number	Front to Rear		Side to Side	
		in.	mm	in.	mm
B Cabinet (17.5")	11M60	22	559	18 - 3/4	476
C Cabinet (21")	11M61	22	559	22 - 3/4	578
D Cabinet (24.5")	11M62	22	559	25 - 3/4	654

- 2 - After opening is cut, set additive base into opening.
- 3 - Check fiberglass strips on additive base to make sure they are properly glued and positioned.
- 4 - Lower supply air plenum into additive base until plenum flanges seal against fiberglass strips.
NOTE - Be careful not to damage fiberglass strips. Check for a tight seal.
- 5 - Set the furnace over the plenum.
- 6 - Ensure that the seal between the furnace and plenum is adequate.

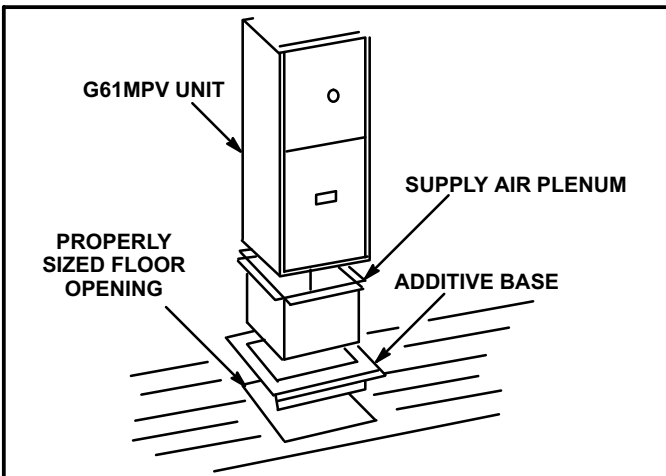

FIGURE 14

Installation on Cooling Coil Cabinet

- 1 - Refer to reverse-flow coil installation instructions for correctly sized opening in floor and installation of cabinet.
- 2 - When cooling cabinet is in place, set and secure the furnace according to the instructions that are provided with the cooling coil. Secure the furnace to the cabinet.
- 3 - Seal the cabinet and check for air leaks.

Return Air Opening -- Downflow Units

Return air may be brought in only through the top opening of a furnace installed in the downflow position. The following steps should be taken when installing plenum:

- 1 - Bottom edge of plenum should be flanged with a hemmed edge (See figure 15 or 16).
- 2 - Sealing strips should be used to ensure an airtight seal between the cabinet and the plenum.
- 3 - In all cases, plenum should be secured to top of furnace using sheet metal screws.
- 4 - Make certain that an adequate seal is made.

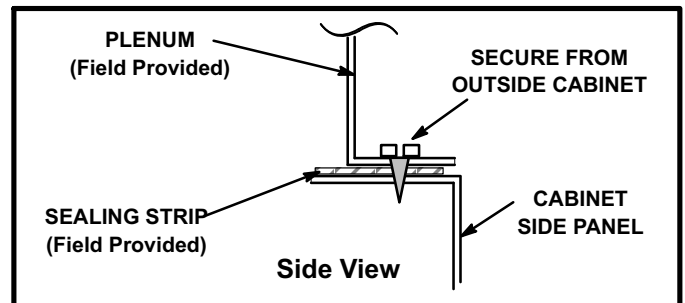

FIGURE 15

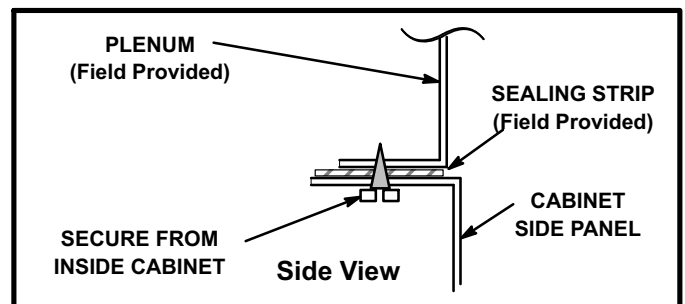

FIGURE 16

Horizontal Applications

The G61MPV furnace can be installed in horizontal applications with either right- or left-hand air discharge.

The G61MPV may also be installed as a unit heater. Either suspend the furnace as shown in figure 18, or install the furnace on a field-fabricated raised platform. The unit must be supported at both ends and beneath the blower deck to prevent sagging.

Refer to figure 17 for clearances in horizontal applications.

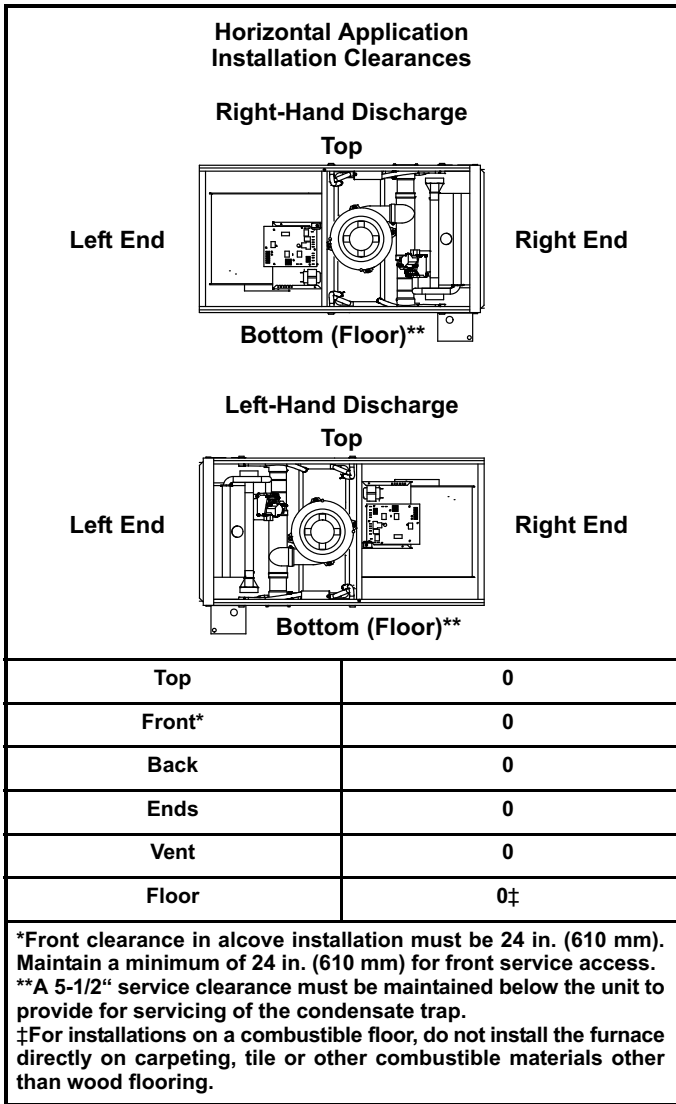

FIGURE 17

Suspended Installation of Horizontal Unit

NOTE - If unit is suspended in attic or crawl space, horizontal support kit (Cat No. 56J18 ordered separately) must be used to ensure proper unit support and coil drainage.

- 1 - Select location for unit keeping in mind service and other necessary clearances. See figure 17.
- 2 - Provide service platform in front of unit.
- 3 - If unit is installed above finished space, fabricate a drain pan fitted with a 1/2 inch or 3/4 inch N.P.T. fitting.
- 4 - Using 3/8 inch rods and support frame kit or field-fabricated supports, fabricate suspension hangers, keeping in mind front service access clearances.
- 5 - Mount unit on support frame as shown in figure 18.
- 6 - Continue with exhaust, condensate and intake line piping instructions.

- 7 - If unit is suspended above finished space, hang the field-provided drain pan below the support frame as shown in figure 18. Leave 5-1/2 inches for service clearance below unit for condensate trap.
- 8 - Route auxiliary drain line so that water draining from this outlet will be easily noticed by the homeowner. If necessary, run the condensate line into a condensate pump to meet drain line slope requirements. The pump must be rated for use with condensing furnaces. Protect the condensate discharge line from the pump to the outside to avoid freezing.

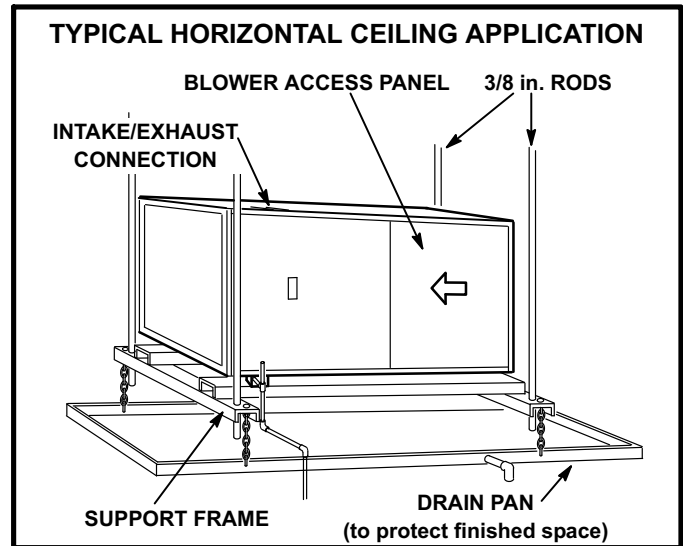

FIGURE 18

Platform Installation of Horizontal Unit

- 1 - Select location for unit keeping in mind service and other necessary clearances. See figure 17.
- 2 - Construct a raised wooden frame and cover frame with a plywood sheet. Provide a service platform in front of unit. If unit is installed above finished space, fabricate a drain pan to be installed under unit. When installing the unit in a crawl space, a proper support platform may be created using cement blocks and the horizontal support frame kit (ordered separately, Lennox part number 56J18). Position the support frame on top of the blocks and install the unit on the frame. Leave 5-1/2 inches for service clearance for condensate trap.
- 3 - Route auxiliary drain line so that water draining from this outlet will be easily noticed by the homeowner. If necessary, run the condensate line into a condensate pump to meet drain line slope requirements. The pump must be rated for use with condensing furnaces. Protect the condensate discharge line from the pump to the outside to avoid freezing.

- 4 - Set unit in drain pan as shown in figure 19. Leave 5-1/2 inches for service clearance below unit for condensate trap.
- 5 - Continue with exhaust, condensate and intake piping installation according to instructions.

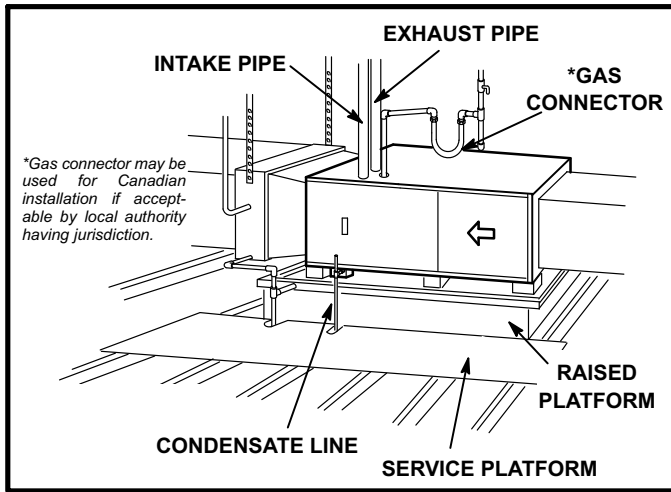

FIGURE 19

G61MPV Installed in Unit Heater Applications

The G61MPV may also be installed as a unit heater. Either suspend the furnace from roof rafters or floor joists, as shown in figure 18, or install the furnace on a field-fabricated raised platform, as shown in figure 19. The unit must be supported at both ends and beneath the blower deck to prevent sagging. The condensate trap must be installed where it can be serviced at a later date.

Unit Heater Discharge Duct Guidelines

A field-fabricated and installed discharge air duct and grille cabinet is suitable for use with the G61MPV heater. Keep the following items in mind when constructing the cabinet.

- 1 - Outer dimensions of cabinet should match those of the unit heater, so the duct/grille cabinet installs flush with the unit heater cabinet. See figure 20.
- 2 - Flange both ends of duct/grille cabinet so that screws can be used to secure cabinet to discharge end of unit heater.
- 3 - To ensure proper operation, the duct/grille cabinet must be at least 18 inches long.

- 4 - Use #10-16 x 1/2 inch sheet metal screws to secure duct/grille cabinet to unit, taking care not to damage internal components of unit heater when drilling holes or installing screws. See figure 20.
- 5 - Use adjustable, double-deflection grille(s) to distribute discharge air. Adjust static pressure to be in the 0.06 inch to 0.10 inch w.c. range.

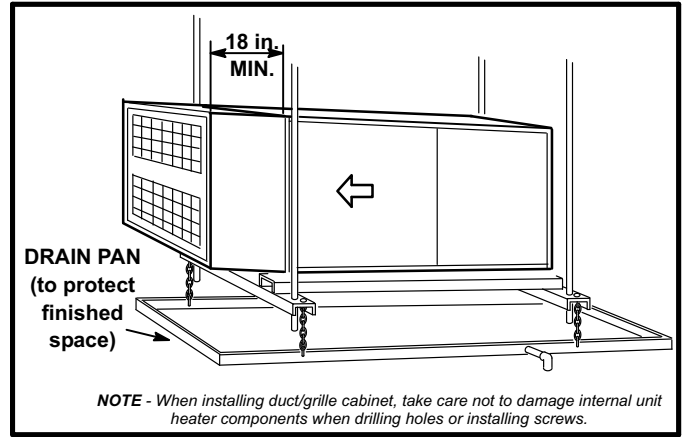

FIGURE 20

Return Air -- Horizontal Applications

Return air may be brought in only through the end of a furnace installed in the horizontal position. The furnace is equipped with a removable bottom panel to facilitate installation. See figure 10.

Filters

This unit is not equipped with a filter or rack. A field-provided filter is required for the unit to operate properly. Table 3 lists recommended filter sizes.

A filter must be in place whenever the unit is operating.

NOTE - In upflow applications where side return air filter is installed on same side as the condensate trap, filter rack must be installed beyond condensate trap to avoid interference.

TABLE 3

Furnace Cabinet Width	Filter Size	
	Side Return	Bottom Return
17-1/2"	16 X 25 X 1 (1)	16 X 25 X 1 (1)
21"	16 X 25 X 1 (1)	20 X 25 X 1 (1)
24-1/2"	16 X 25 X 1 (2)	24 X 25 X 1 (1)

Duct System

Use industry-approved standards to size and install the supply and return air duct system. This will result in a quiet and low-static system that has uniform air distribution.

NOTE - Operation of this furnace in heating mode (indoor blower operating at selected heating speed) with an external static pressure which exceeds 0.8 inches w.c. may result in erratic limit operation.

Supply Air Plenum

If the furnace is installed without a cooling coil, a removable access panel should be installed in the supply air duct. The access panel should be large enough to permit inspection (by reflected light) of the heat exchanger for leaks after the furnace is installed. If present, this access panel must always be in place when the furnace is operating and it must not allow leaks into the supply air duct system.

Return Air Plenum

NOTE - Return air must not be drawn from a room where this furnace, or any other gas-fueled appliance (i.e., water heater), or carbon monoxide-producing device (i.e., wood fireplace) is installed.

When return air is drawn from a room, a negative pressure is created in the room. If a gas appliance is operating in a room with negative pressure, the flue products can be pulled back down the vent pipe and into the room. This reverse flow of the flue gas may result in incomplete combustion and the formation of carbon monoxide gas. This toxic gas might then be distributed throughout the house by the furnace duct system.

Return air can be brought in through the bottom or either side of the furnace. If a furnace with bottom return air is installed on a platform, make an airtight seal between the bottom of the furnace and the platform to ensure that the unit operates properly and safely. Use fiberglass sealing strips, caulking, or equivalent sealing method between the plenum and the furnace cabinet to ensure a tight seal. If a filter is installed, size the return air duct to fit the filter frame.

Pipe & Fittings Specifications

All pipe, fittings, primer and solvent cement must conform with American National Standard Institute and the American Society for Testing and Materials (ANSI/ASTM) standards. The solvent shall be free flowing and contain no lumps, undissolved particles or any foreign matter that ad-

versely affects the joint strength or chemical resistance of the cement. The cement shall show no gelation, stratification, or separation that cannot be removed by stirring. Refer to the table 4 below for approved piping and fitting materials.

⚠ CAUTION

Solvent cements for plastic pipe are flammable liquids and should be kept away from all sources of ignition. Do not use excessive amounts of solvent cement when making joints. Good ventilation should be maintained to reduce fire hazard and to minimize breathing of solvent vapors. Avoid contact of cement with skin and eyes.

**TABLE 4
PIPING AND FITTINGS SPECIFICATIONS**

PIPE & FITTING MATERIAL	ASTM SPECIFICATION
Schedule 40 PVC (Pipe)	D1785
Schedule 40 PVC (Cellular Core Pipe)	F891
Schedule 40 PVC (Fittings)	D2466
Schedule 40 CPVC (Pipe)	F441
Schedule 40 CPVC (Fittings)	F438
SDR-21 PVC or SDR-26 PVC (Pipe)	D2241
SDR-21 CPVC or SDR-26 CPVC (Pipe)	F442
Schedule 40 ABS Cellular Core DWV (Pipe)	F628
Schedule 40 ABS (Pipe)	D1527
Schedule 40 ABS (Fittings)	D2468
ABS-DWV (Drain Waste & Vent) (Pipe & Fittings)	D2661
PVC-DWV (Drain Waste & Vent) Pipe & Fittings)	D2665
PRIMER & SOLVENT CEMENT	ASTM SPECIFICATION
PVC & CPVC Primer	F656
PVC Solvent Cement	D2564
CPVC Solvent Cement	F493
ABS Solvent Cement	D2235
PVC/CPVC/ABS All Purpose Cement For Fittings & Pipe of the same material	D2564, D2235, F493
ABS to PVC or CPVC Transition Solvent Cement	D3138
CANADA PIPE & FITTING & SOLVENT CEMENT	MARKING
PVC & CPVC Pipe and Fittings	ULCS636
PVC & CPVC Solvent Cement	
ABS to PVC or CPVC Transition Cement	

Use PVC primer and solvent cement or ABS solvent cement meeting ASTM specifications, refer to Table 4. As an alternate, use all purpose cement, to bond ABS, PVC, or CPVC pipe when using fittings and pipe made of the same materials. Use transition solvent cement when bonding ABS to either PVC or CPVC.

Low temperature solvent cement is recommended. Metal or plastic strapping may be used for vent pipe hangers. Uniformly apply a liberal coat of PVC primer for PVC or use a clean dry cloth for ABS to clean inside socket surface of fitting and male end of pipe to depth of fitting socket.

Canadian Applications Only - Pipe, fittings, primer and solvent cement used to vent (exhaust) this appliance must be certified to ULC S636 and supplied by a single manufacturer as part of an approved vent (exhaust) system. When bonding the vent system to the furnace, use ULC S636 approved One-Step Transition Cement to bond the pipe to the flue collar, or to bond the 90° elbow or reducing 90° elbow to the flue collar. In addition, the first three feet of vent pipe from the furnace flue collar must be accessible for inspection.

Table 5 lists the available exhaust termination kits, as well as vent pipe equivalencies which must be used when sizing vent pipe. All Lennox vent terminations are PVC.

**TABLE 5
OUTDOOR TERMINATION KITS AND CORRESPONDING EQUIVALENCIES**

UNIT MODEL	VENT PIPE DIA. (in.)	Vent Pipe Length Equivalency (feet)									
		Outdoor Exhaust Accelerator (Dia. X Length)	Outdoor Exhaust Accelerator (Dia. X Length)	1-1/2" Concentric Kit	2" Concentric Kit	3" Concentric Kit	2" Wall Plate Kit	3" Wall Plate Kit	2" Wall Ring Kit	Flush Mount Termination	
		1-1/2" X 12"	2" X 12"	71M80 or †44W92††	69M29 or †44W92††	60L46 or 44W93†	22G44 or 30G28†	44J40 or 81J20†	15F74	51W11 with 1-1/2" accelerator	51W11 without 1-1/2" accelerator
36B-045	2	4	Not Allowed	12	Not Allowed	Not Allowed	4	4*	4	4	Not Allowed
	2-1/2	5	Not Allowed	15	Not Allowed	Not Allowed	5	5*	5	7****	Not Allowed
	3	7	Not Allowed	21	Not Allowed	Not Allowed	7	7*	7	7	Not Allowed
	4	14	Not Allowed	42	Not Allowed	Not Allowed	14	14*	14	Not Allowed	Not Allowed
36B-070 36B-071	2	4	Not Allowed	12	Not Allowed	Not Allowed	4	4*	4	4	Not Allowed
	2-1/2	5	Not Allowed	15	Not Allowed	Not Allowed	5	5*	5	7****	Not Allowed
	3	8	Not Allowed	24	Not Allowed	Not Allowed	8	8*	8	8	Not Allowed
	4	14	Not Allowed	42	Not Allowed	Not Allowed	14	14*	14	Not Allowed	Not Allowed
36B-091 60C-090	2	Not Allowed	1	Not Allowed	3	3	Not Allowed	1	1**	4	Not Allowed
	2-1/2	Not Allowed	2	Not Allowed	6	6	Not Allowed	2	2**	7****	Not Allowed
	3	Not Allowed	2	Not Allowed	6	6	Not Allowed	2	2**	8	Not Allowed
	4	Not Allowed	4	Not Allowed	12	12	Not Allowed	4	4**	Not Allowed	Not Allowed
60C-110 60C-111	2	Not Allowed	1	Not Allowed	3	3	Not Allowed	1	1**	Not Allowed	1
	2-1/2	Not Allowed	2	Not Allowed	6	6	Not Allowed	2	2***	Not Allowed	4****
	3	Not Allowed	2	Not Allowed	6	6	Not Allowed	2	2***	Not Allowed	7
	4	Not Allowed	4	Not Allowed	12	12	Not Allowed	4	4***	Not Allowed	Not Allowed
60D-135	3	Not Allowed	6	Not Allowed	Not Allowed	15	Not Allowed	6	6***	Not Allowed	7
	4	Not Allowed	10	Not Allowed	Not Allowed	25	Not Allowed	10	10***	Not Allowed	Not Allowed

*Requires field-provided and installed 1-1/2" exhaust accelerator.

**Requires field-provided and installed 2" exhaust accelerator.

***For use only in non-direct vent applications, when snow riser is not required. Requires field-provided and installed 2" exhaust accelerator.

**** Requires field-provided and installed 2"-2-1/2" coupling on G61MPV-36B-045, G61MPV-36B-070, 071, G61MPV-36B-090,091 and G61MPV-60C-110 furnaces

† Termination kits 44W92, 44W93, 30G28 & 81J20 are ULC-636 approved for Canadian Installation.

†† The 44W92 Concentric kit is provided with a 1-1/2" accelerator which must be installed on the exhaust outlet when this kit is used with the G61MPV-36B-045, G61MPV-36B-070 & 071 furnaces.

Vent Piping Guidelines

The G61MPV can be installed as either a Non-Direct Vent or a Direct Vent gas central furnace.

NOTE - In Non-Direct Vent installations, combustion air is taken from indoors and flue gases are discharged outdoors. In Direct Vent installations, combustion air is taken from outdoors and flue gases are discharged outdoors.

Intake and exhaust pipe sizing in Direct Vent applications and exhaust pipe sizing in Non-Direct Vent applications -- Size pipe according to tables 6 and 7. Table 6 lists the minimum equivalent vent pipe lengths permitted. Table 7 lists the maximum equivalent pipe lengths permitted.

Maximum vent length is defined as:

Total length (linear feet) of pipe,
Plus Equivalent length (feet) of fittings,
Plus Equivalent length (feet) of termination.

NOTE - Include ALL pipe and ALL fittings, both in doors and outdoors.

Regardless of the diameter of pipe used, the standard roof and wall terminations described in section *Exhaust Piping Terminations* should be used. Exhaust vent termination pipe is sized to optimize the velocity of the exhaust gas as it exits the termination. Refer to table 8.

NOTE - The exhaust pipe should be offset a minimum of 12 inches to avoid the possibility of water droplets being released from the exhaust termination. The minimum exhaust vent length is 15 ft. Shorter exhaust vent lengths may result in the discharge of water droplets from the exhaust termination, in spite of the 12-inch vertical offset. See figure 21.

Each 90° elbow (including those provided with the furnace) of any diameter is equivalent to 5 feet (1.52m) of vent pipe of the same diameter. Two 45° elbows are equivalent to one 90° elbow of the same diameter. One 45° elbow is equal to 2.5 feet (.76m) of vent pipe of the same diameter.

NOTE - On G61MPV-071, -091 and -111 units, sweep elbows must be used for all 90° elbows in the venting system when 2", 2-1/2" or 3" vent pipe is used. On G61MPV-135, sweep elbows must be used for all 90° elbows in the venting system when 3" vent pipe is used. Sweep elbows are recommended for use in vent systems of other G61MPV units.

In some applications which permit the use of several different sizes of vent pipe, a combination vent pipe may be used. Contact Lennox' Application Department for assistance in sizing vent pipe in these applications.

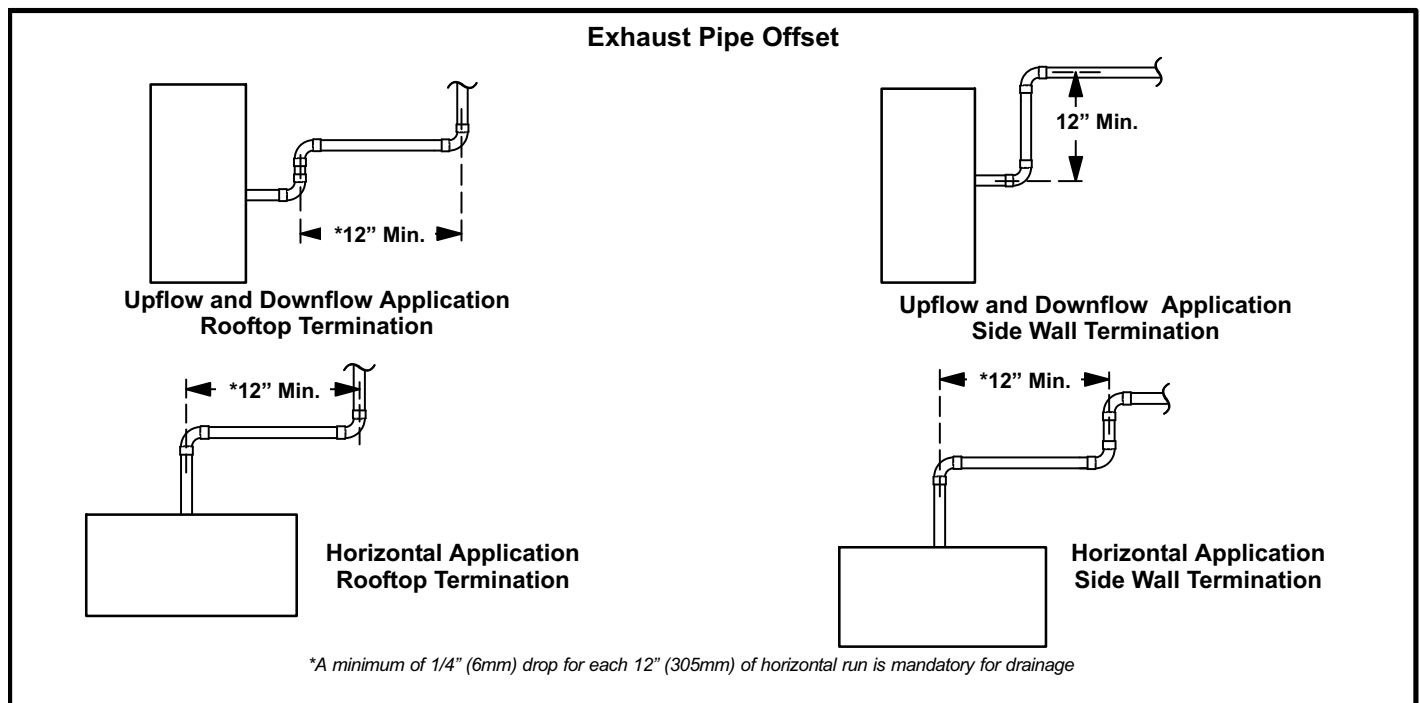

FIGURE 21

NOTE - The flue collar on all models is sized to accommodate 2" Schedule 40 flue pipe. When vent pipe which is larger than 2" must be used in an upflow application, a 2" elbow must be applied at the flue collar in order to properly transition to the larger diameter flue pipe. This elbow must be added to the elbow count used to determine acceptable vent lengths. Assign an equivalent feet value to this elbow according to the larger size pipe being used. Contact the Application Department for more information concerning sizing of vent systems which include multiple pipe sizes.

Use the following steps to correctly size vent pipe diameter. **Refer to Vent Pipe Size Determination Worksheet on page 65.**

- 1 - Determine the vent termination and its corresponding equivalent feet value according to table 5.
- 2 - Determine the number of 90° elbows required for both indoor and outdoor (e.g. snow riser) use. Calculate the corresponding equivalent feet of vent pipe.
- 3 - Determine the number of 45° elbows required for both indoor and outdoor use. Calculate the corresponding equivalent feet of vent pipe.
- 4 - Determine the length of straight pipe required.
- 5 - Add the total equivalent feet calculated in steps 1 through 4 and compare that length to the maximum values given in table 7 for the proposed vent pipe diameter. If the total equivalent length required exceeds the maximum equivalent length listed in the appropriate table, evaluate the next larger size pipe.

⚠ IMPORTANT

Do not use screens or perforated metal in exhaust terminations. Doing so will cause freeze-ups and may block the terminations.

**TABLE 6
MINIMUM VENT PIPE LENGTHS**

G61MPV MODEL	MIN. EQUIV. VENT LENGTH	EXAMPLE
045, 070, 071, 090, 091	15 ft.*	5 ft. plus 2 elbows of 2", 2-1/2", 3" or 4" diameter pipe
110		5 ft. plus 2 elbows of 2-1/2" 3" or 4" diameter pipe
135***		5 ft. plus 2 elbows of 3" or 4" diameter pipe

*Any approved termination may be added to the minimum equivalent length listed.

**G61MPV-60C-110 and -111 must have 90° street ell (supplied or field replacement Canadian kit) installed directly into unit flue collar.

***G61MPV-60D-135 must have 3" to 2" reducing ell (supplied or field replacement Canadian kit) installed directly into unit flue collar.

**TABLE 7
MAXIMUM VENT PIPE LENGTHS**

ALTITUDE	G61MPV MODEL	MAXIMUM EQUIVALENT VENT LENGTH FEET			
		2" PIPE	2-1/2" PIPE	3" PIPE	4" PIPE
0 - 4500 (0 - 1371 m)	045	59	65	77	234
	070	59	65	78	214
	071†	59	65	78	214
	090	26	42	72	204
	091†	26	42	72	204
	110*	n/a	32	72	179
	111*†	n/a	32	72	179
135**‡	n/a	n/a	61	160	
4501-7500 (1372-2286 m)	045	59	65	77	234
	070	59	65	78	214
	071†	59	65	78	214
	090	26	42	72	204
	091†	26	42	72	204
	110*	n/a	32	72	179
	111*†	n/a	32	72	179
135**‡	n/a	n/a	46	160	
7501 - 10000 (2287 - 3048 m)	045	59	65	77	234
	070	59	65	78	214
	071†	59	65	78	214
	090	26	42	72	204
	091†	26	42	72	204
	110*	n/a	32	72	179
	111*†	n/a	32	72	179
135**‡	n/a	n/a	46	160	

n/a -- Not allowed.

*G61MPV-60C-110 and -111 must have 90° street ell (supplied or field replacement Canadian kit) installed directly into unit flue collar.

**G61MPV-60D-135 must have 3" to 2" reducing ell (supplied or field replacement Canadian kit) installed directly into unit flue collar.

†On G61MPV-071, -091 and -111 units, sweep elbows must be used for all 90° elbows in the venting system when 2", 2-1/2" or 3" vent pipe is used. Sweep elbows are recommended for use in vent systems of other G61MPV units.

‡On G61MPV-60D-135 units, sweep elbows must be used for all 90° elbows in the vent system when 3" vent pipe is used.

Joint Cementing Procedure

All cementing of joints should be done according to the specifications outlined in ASTM D 2855.

⚠ WARNING

DANGER OF EXPLOSION!

Fumes from PVC glue may ignite during system check. Allow fumes to dissipate for at least 5 minutes before placing unit into operation.

- 1 - Measure and cut vent pipe to desired length.
- 2 - Debur and chamfer end of pipe, removing any ridges or rough edges. If end is not chamfered, edge of pipe may remove cement from fitting socket and result in a leaking joint.
- 3 - Clean and dry surfaces to be joined.
- 4 - Test fit joint and mark depth of fitting on outside of pipe.

- 5 - Uniformly apply a liberal coat of PVC primer for PVC or use a clean dry cloth for ABS to clean inside socket surface of fitting and male end of pipe to depth of fitting socket.

NOTE - Furnace flue collar and air inlet fitting are both made of ABS material. Use transition solvent cement when bonding ABS to either PVC or CPVC, refer to the procedure specified in ASTM D3138..

- 6 - Promptly apply solvent cement to end of pipe and inside socket surface of fitting. Cement should be applied lightly but uniformly to inside of socket. Take care to keep excess cement out of socket. Apply second coat to end of pipe.

NOTE - Time is critical at this stage. Do not allow primer to dry before applying cement.

- 7 - Immediately after applying last coat of cement to pipe, and while both inside socket surface and end of pipe are wet with cement, forcefully insert end of pipe into socket until it bottoms out. Turn PVC pipe 1/4 turn during assembly (but not after pipe is fully inserted) to distribute cement evenly. DO NOT turn ABS or cellular core pipe.

NOTE - Assembly should be completed within 20 seconds after last application of cement. Hammer blows should not be used when inserting pipe.

- 8 - After assembly, wipe excess cement from pipe at end of fitting socket. A properly made joint will show a bead around its entire perimeter. Any gaps may indicate a defective assembly due to insufficient solvent.
- 9 - Handle joints carefully until completely set.

Venting Practices

The thickness of construction through which vent pipes may be installed is 24" (610mm) maximum and 3/4" (19mm) minimum. If a G61MPV furnace replaces a furnace which was commonly vented with another gas appliance, the size of the existing vent pipe for that gas appliance must be checked. Without the heat of the original furnace flue products, the existing vent pipe is probably oversized for the single water heater or other appliance. The vent should be checked for proper draw with the remaining appliance.

- 1 - Use recommended piping materials for exhaust piping.
- 2 - Secure all joints so that they are gas-tight using approved cement.

Suspend piping using hangers at a minimum of every 5 feet (1.52m) for schedule 40 PVC and every 3 feet (.91m) for ABS-DWV, PVC-DWV, SPR-21 PVC, and SDR-26 PVC piping. A suitable hanger can be fabricated by using metal or plastic strapping or a large wire tie.

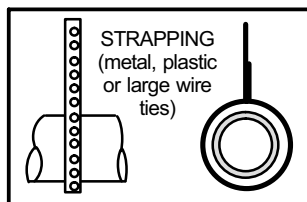

FIGURE 22

- 3 - In areas where piping penetrates joists or interior walls, hole must be large enough to allow clearance on all sides of pipe through center of hole using a hanger.

- 4 - Isolate piping at the point where it exits the outside wall or roof in order to prevent transmission of vibration to the structure.

- 5 - When furnace is installed in a residence where unit is shut down for an extended period of time, such as a vacation home, make provisions for draining condensate collection trap and lines.

Exhaust Piping (Figures 23 and 24)

NOTE - A 2" diameter PVC street ell is located on the blower deck of 60C-110 and 60C-111 units. **In upflow or downflow applications** the street ell **must be** glued using transition solvent cement directly into the unit flue collar. See figure 23. A 3" to 2" PVC reducing ell is located on the blower deck of the 60D-135 units. **In upflow or downflow applications**, the reducing ell **must be** glued using transition solvent cement directly into the unit flue collar.

- 1 - Choose the appropriate side for venting in upflow or downflow positions. Exhaust piping exits from the top of the unit in horizontal air discharge applications. Glue the field-provided exhaust vent pipe (or provided street ell or reducing ell in upflow or downflow applications) to the flue collar. All PVC cement joints should be made according to the specifications outlined in ASTM D 2855. Refer to pipe and fittings specifications and gluing procedures.

▲ IMPORTANT

Exhaust piping and condensate trap must be installed on the same side of the unit in upflow and downflow applications or use alternate drain kit 76M20.

- 2 - All horizontal runs of exhaust pipe must slope back toward unit. A minimum of 1/4" (6mm) drop for each 12" (305mm) of horizontal run is mandatory for drainage. Horizontal runs of exhaust piping must be supported every 5 feet (1.52m) using hangers.

NOTE - Exhaust piping should be checked carefully to make sure there are no sags or low spots.

- 3 - On the opposite side of the cabinet, glue the provided 2" ABS vent plug into the unused ABS flue collar with ABS or all purpose solvent cement.
- 4 - Route piping to outside of structure. Continue with installation following instructions given in piping termination section.

▲ CAUTION

Do not discharge exhaust into an existing stack or stack that also serves another gas appliance. If vertical discharge through an existing unused stack is required, insert PVC pipe inside the stack until the end is even with the top or outlet end of the metal stack.

▲ CAUTION

The exhaust vent pipe operates under positive pressure and must be completely sealed to prevent leakage of combustion products into the living space.

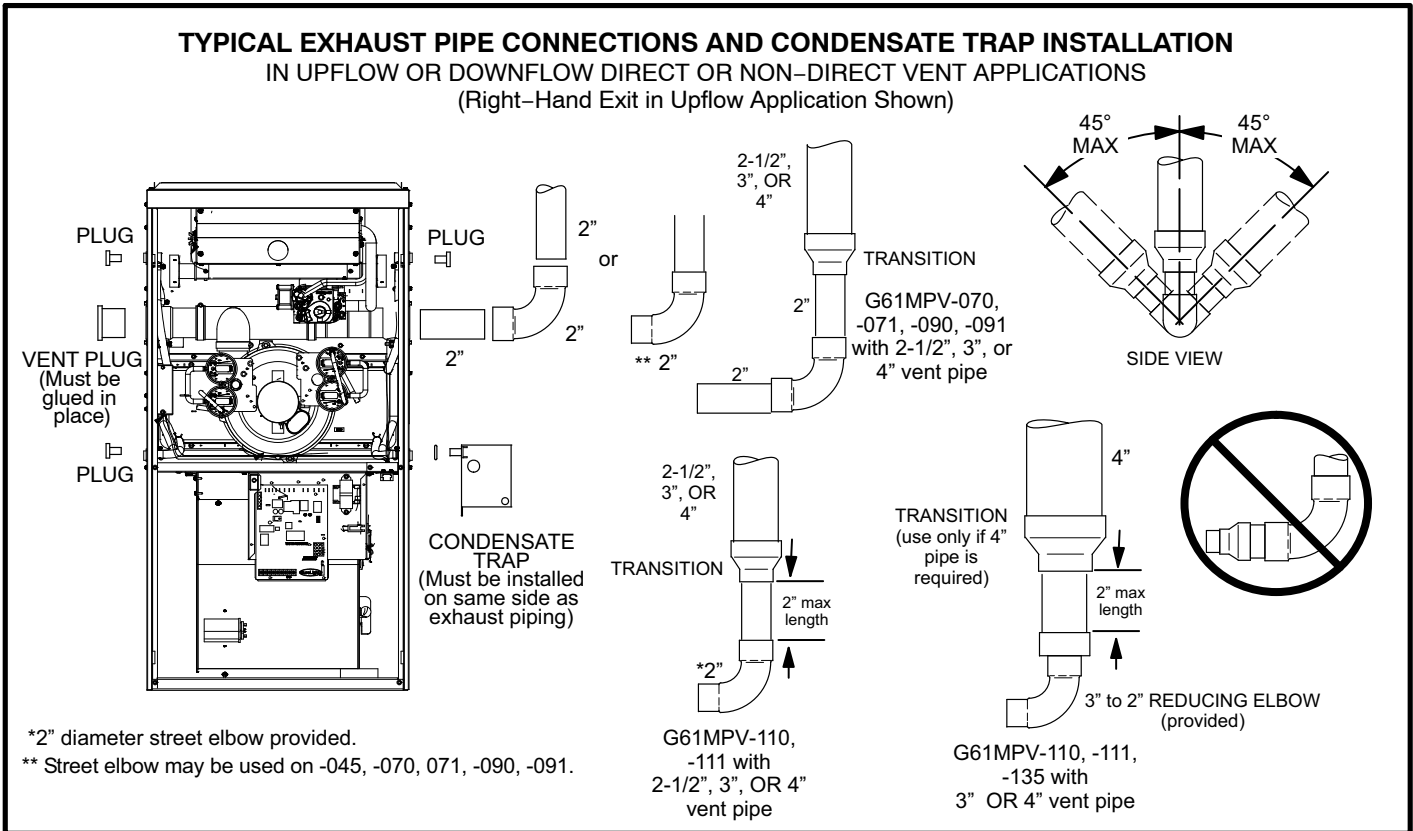

FIGURE 23

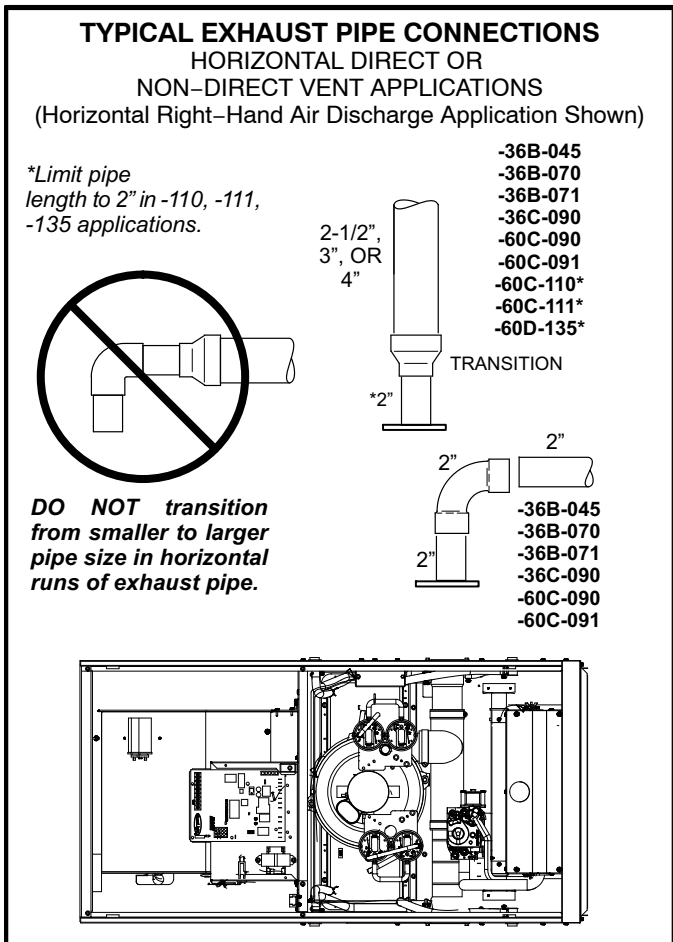

FIGURE 24

Intake Piping

The G61MPV furnace may be installed in either **direct vent** or **non-direct vent** applications. In non-direct vent applications, when intake air will be drawn into the furnace from the surrounding space, the indoor air quality must be considered and guidelines listed in Combustion, Dilution and Ventilation Air section must be followed.

The G61MPV unit is designed for either left-side or right-side air intake connections in either upflow or downflow applications. In horizontal applications, air intake must be brought in through the top. Intake air piping is independent of exhaust piping.

Follow the next four steps when installing the unit in **direct vent applications**, where combustion air is taken from outdoors and flue gases are discharged outdoors. **The provided air intake screen must not be used in direct vent applications.**

- 1 - Use transition solvent cement to connect PVC pipe to the ABS slip connector located on the side of the burner box.
- 2 - Use a sheet metal screw to secure the intake pipe to the connector, if desired. A pilot indentation is provided in the slip connector to assist in locating and starting the fastener.
- 3 - Glue the provided 2" ABS plug into the unused ABS air intake connector on the opposite side of the cabinet with ABS all purpose cement.
- 4 - Route piping to outside of structure. Continue with installation following instructions given in general guide lines for piping terminations and in intake and exhaust piping terminations for direct vent sections. Refer to figure 25 for pipe sizes.

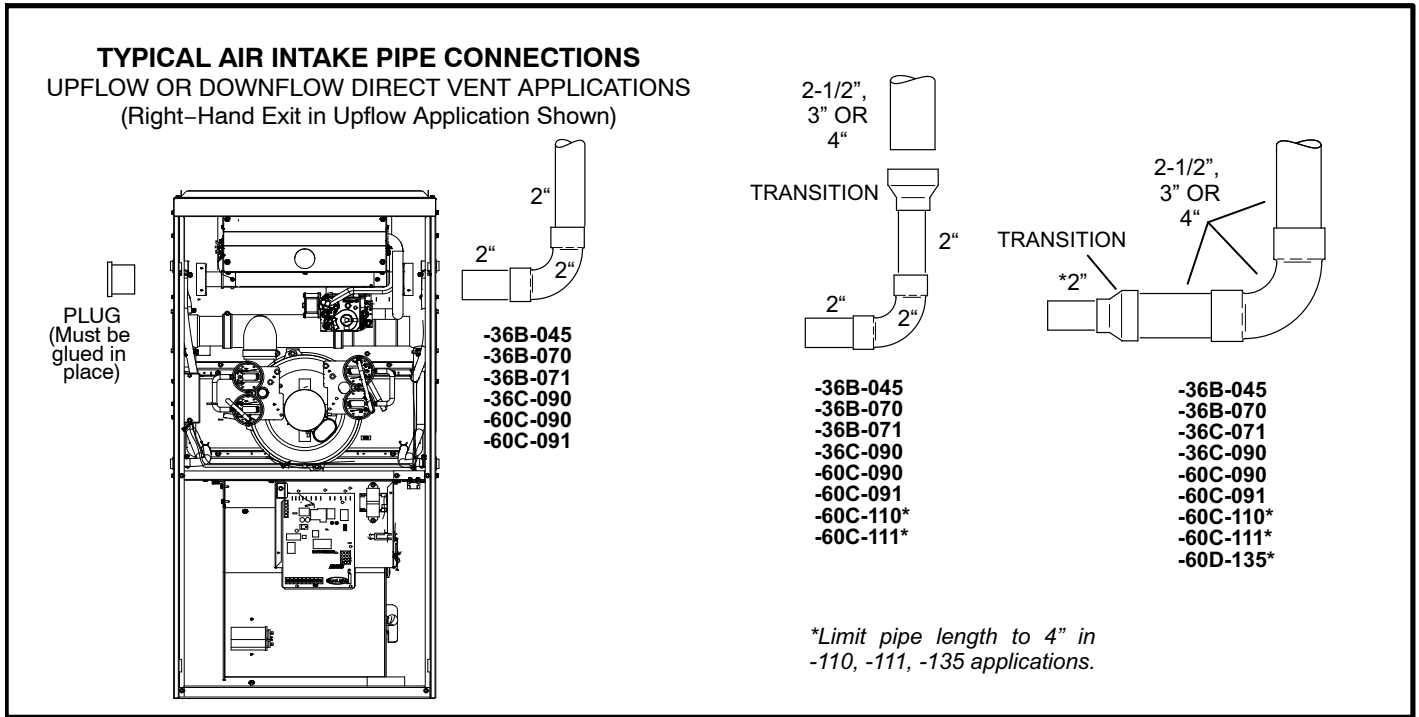

FIGURE 25

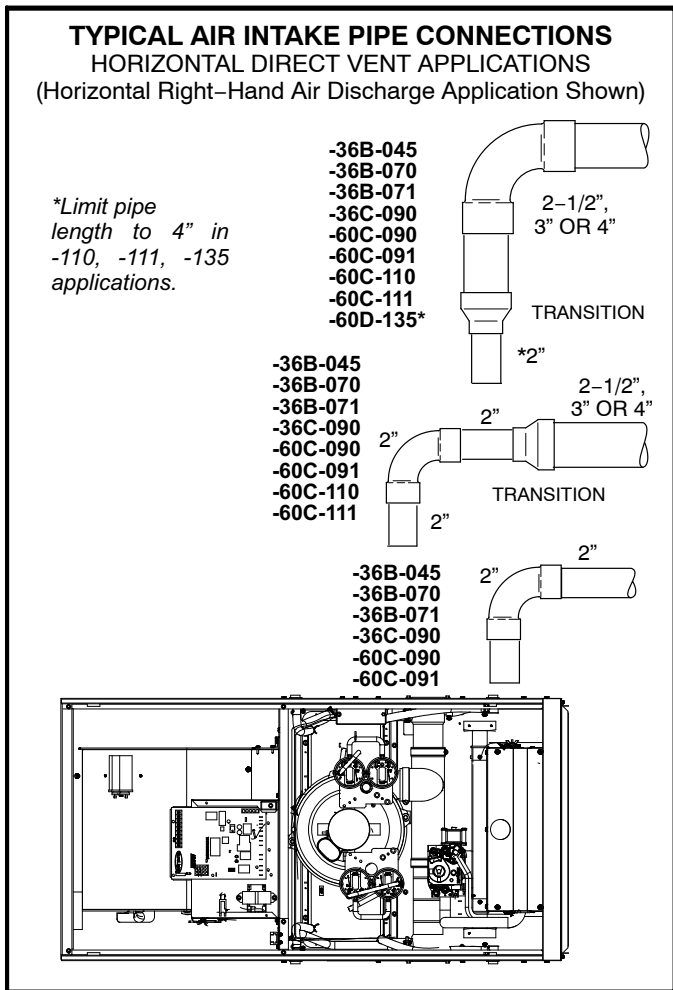

FIGURE 26

Follow the next three steps when installing the unit in **Non-Direct Vent applications** where combustion air is taken from indoors and flue gases are discharged outdoors.

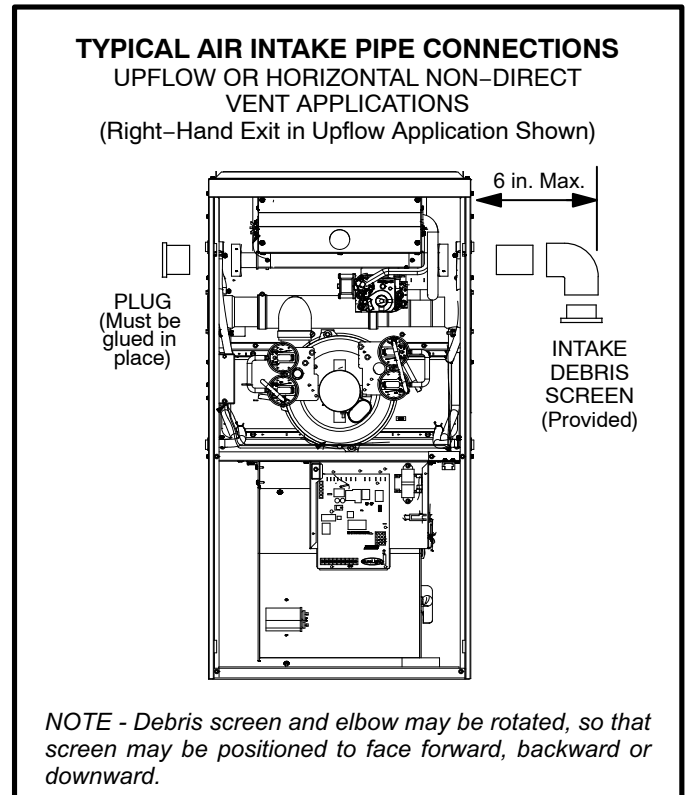
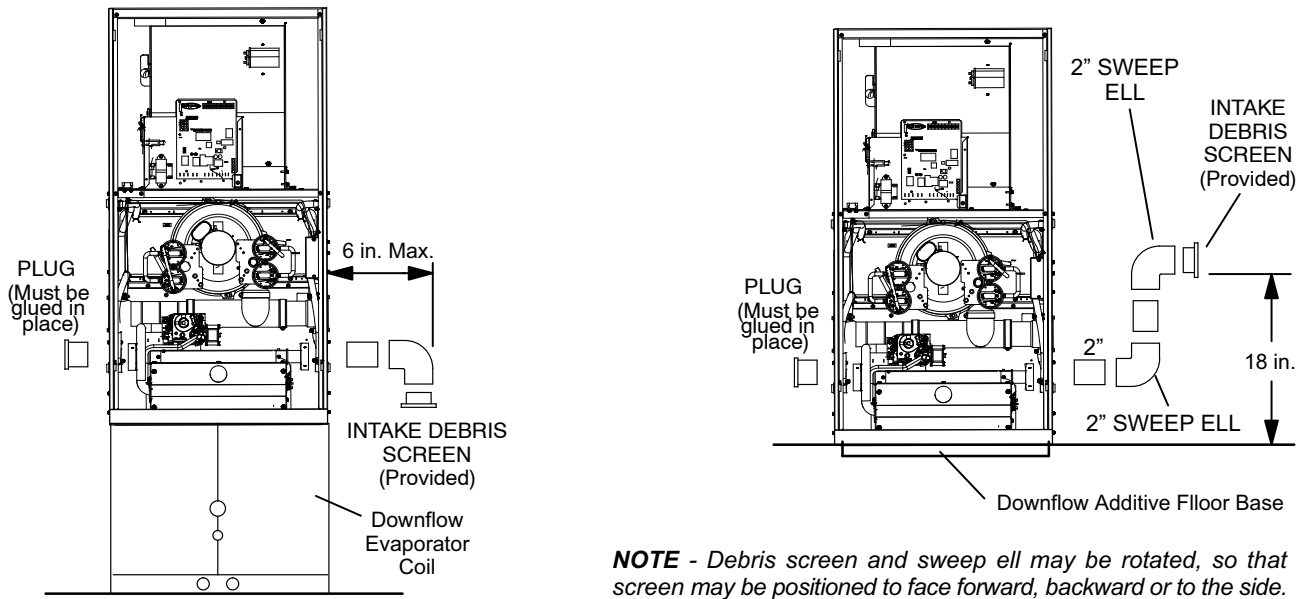

FIGURE 27

TYPICAL AIR INTAKE PIPE CONNECTIONS
DOWNFLOW NON-DIRECT VENT APPLICATIONS
 (Right-Hand Exit in Downflow Applications Shown)



NOTE - Debris screen and sweep ell may be rotated, so that screen may be positioned to face forward, backward or to the side.

FIGURE 28

1 - Use field-provided materials and the factory-provided air intake screen to route the intake piping as shown in figures 27 and 28. Maintain a minimum clearance of 3" (76mm) around the air intake opening. The air intake opening (with the protective screen) should always be directed either downward or straight out. Use 2" pipe and fittings only and make sure that the air intake does not extend more than 6" beyond the G61MPV cabinet. **The air intake connector must not be located near the floor. To avoid this complication in downflow applications which do not include a downflow**

evaporator coil, the intake air routing should be modified as shown in figure 28.

- 2 - Use a sheet metal screw to secure the intake pipe to the connector, if desired. A pilot indentation is provided in the slip connector to assist in locating and starting the fastener.
- 3 - Glue the provided 2" ABS plug into the unused ABS air intake connector on the opposite side of the cabinet with ABS or all purpose solvent cement.

General Guidelines for Vent Terminations

In Non-Direct Vent applications, combustion air is taken from indoors and the flue gases are discharged to the outdoors. The G61MPV is then classified as a non-direct vent, Category IV gas furnace.

In Direct Vent applications, combustion air is taken from outdoors and the flue gases are discharged to the outdoors. The G61MPV is then classified as a direct vent, Category IV gas furnace.

In both Non-Direct Vent and Direct Vent applications, the vent termination is limited by local building codes. In the absence of local codes, refer to the current National Fuel Gas Code ANSI Z223-1/NFPA 54 in U.S.A., and current CSA-B149 Natural Gas and Propane Installation Codes in Canada for details.

Position termination according to location given in figure 29 or 30. In addition, position termination so it is free from any obstructions and 12" above the average snow accumulation.

At vent termination, care must be taken to maintain protective coatings over building materials (prolonged exposure to exhaust condensate can destroy protective coatings). It is recommended that the exhaust outlet not be located within 6 feet (1.8m) of a condensing unit because the condensate can damage the painted coating.

NOTE - If winter design temperature is below 32°F (0°C), exhaust piping should be insulated with 1/2" (13mm), Armaflex or equivalent when run through unheated space. Do not leave any surface area of exhaust pipe open to outside air; exterior exhaust pipe should be insulated with 1/2" (13mm) Armaflex or equivalent. In extreme cold climate areas, 3/4" (19mm) Armaflex or equivalent may be necessary. Insulation on outside runs of exhaust pipe must be painted or wrapped to protect insulation from deterioration. Exhaust pipe insulation may not be necessary in some specific applications.

NOTE - During extremely cold temperatures, below approximately 20°F (6.7°C), units with long runs of vent pipe through unconditioned space, even when insulated, may form ice in the exhaust termination that prevents the unit from operating properly. Longer run times of at least 5 minutes will alleviate most icing problems. Also, a heating cable may be installed on exhaust piping and termination to prevent freeze-ups. Heating cable installation kit is available from Lennox. See Condensate Piping section for part numbers.

IMPORTANT

Do not use screens or perforated metal in exhaust terminations. Doing so will cause freeze-ups and may block the terminations.

IMPORTANT

**For Canadian Installations Only:
In accordance to CSA International B149 installation codes, the minimum allowed distance between the combustion air intake inlet and the exhaust outlet of other appliances shall not be less than 12 inches (305mm).**

VENT TERMINATION CLEARANCES FOR NON-DIRECT VENT INSTALLATIONS IN THE USA AND CANADA

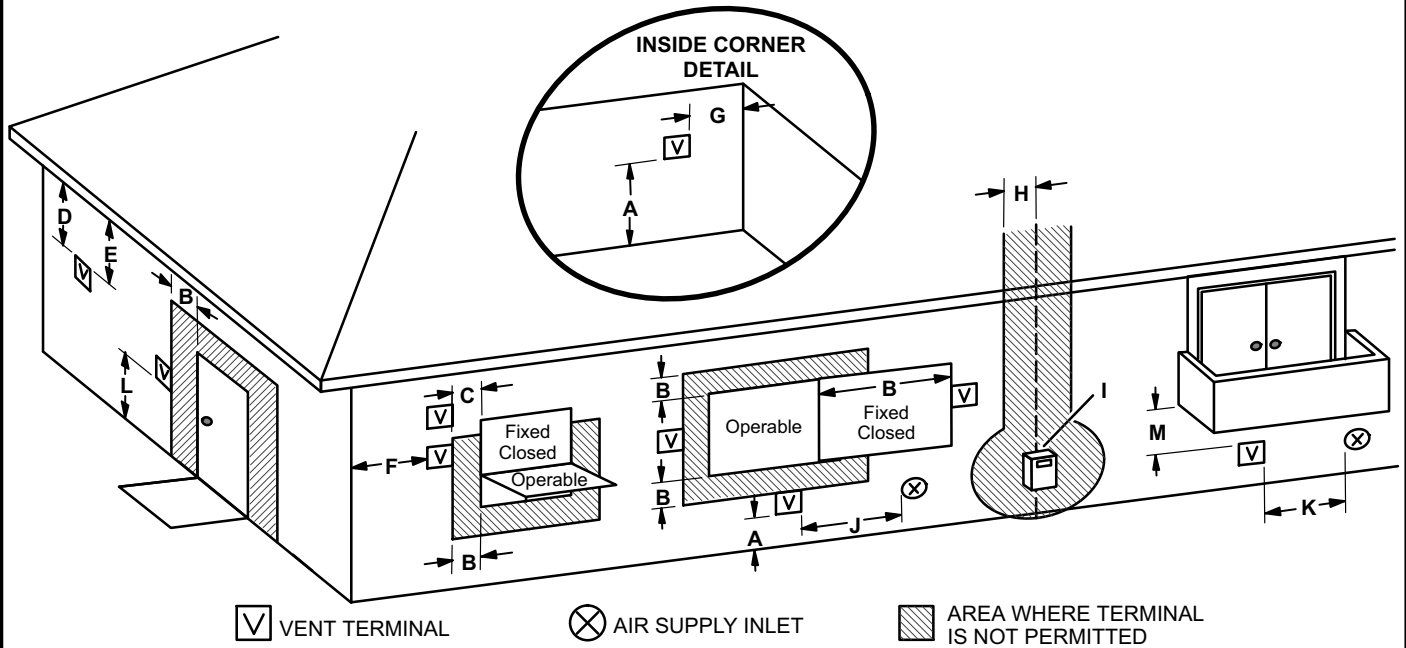

	US Installations ¹	Canadian Installations ²	
A =	Clearance above grade, veranda, porch, deck or balcony	12 inches (305mm) or 12 in. 305mm above average snow accumulation.	12 inches (305mm) or 12 in. 305mm above average snow accumulation.
B =	Clearance to window or door that may be opened	4 feet (1.2 m) below or to side of opening; 1 foot (30 cm) above opening	6 inches (152mm) for appliances <10,000 Btuh (3kw), 12 inches (305mm) for appliances > 10,000 Btuh (3kw) and <100,000 Btuh (30kw), 36 inches (.9m) for appliances > 100,000 Btuh (30kw)
C =	Clearance to permanently closed window	* 12"	* 12"
D =	Vertical clearance to ventilated soffit located above the terminal within a horizontal distance of 2 feet (mm) from the center line of the terminal	* Equal to or greater than soffit depth.	* Equal to or greater than soffit depth.
E =	Clearance to unventilated soffit	* Equal to or greater than soffit depth.	* Equal to or greater than soffit depth.
F =	Clearance to outside corner	* No minimum to outside corner	* No minimum to outside corner
G =	Clearance to inside corner	*	*
H =	Clearance to each side of center line extended above meter / regulator assembly	* 3 feet (.9m) within a height 15 feet (4.5m) above the meter / regulator assembly	3 feet (.9m) within a height 15 feet (4.5m) above the meter / regulator assembly
I =	Clearance to service regulator vent outlet	* 3 feet (.9m)	3 feet (.9m)
J =	Clearance to non-mechanical air supply inlet to building or the combustion air inlet to any other appliance	4 feet (1.2 m) below or to side of opening; 1 foot (30 cm) above opening	6 inches (152mm) for appliances <10,000 Btuh (3kw), 12 inches (305mm) for appliances > 10,000 Btuh (3kw) and <100,000 Btuh (30kw), 36 inches (.9m) for appliances > 100,000 Btuh (30kw)
K =	Clearance to mechanical air supply inlet	3 feet (.9m) above if within 10 feet (3m) horizontally	6 feet (1.8m)
L =	Clearance above paved sidewalk or paved driveway located on public property	7 feet (2.1m)†	7 feet (2.1m)†
M =	Clearance under veranda, porch, deck or balcony	*12 inches (305mm)‡	12 inches (305mm)‡

¹ In accordance with the current ANSI Z223.1/NFPA 54 Natural Fuel Gas Code

² In accordance with the current CSA B149.1, Natural Gas and Propane Installation Code

† A vent shall not terminate directly above a sidewalk or paved driveway that is located between two single family dwellings and serves both dwellings.

‡ Permitted only if veranda, porch, deck or balcony is fully open on a minimum of two sides beneath the floor. Lennox recommends avoiding this location if possible.

*For clearances not specified in ANSI Z223.1/NFPA 54 or CSA B149.1, clearance will be in accordance with local installation codes and the requirements of the gas supplier and these installation instructions."

FIGURE 29

VENT TERMINATION CLEARANCES FOR DIRECT VENT INSTALLATIONS IN THE USA AND CANADA

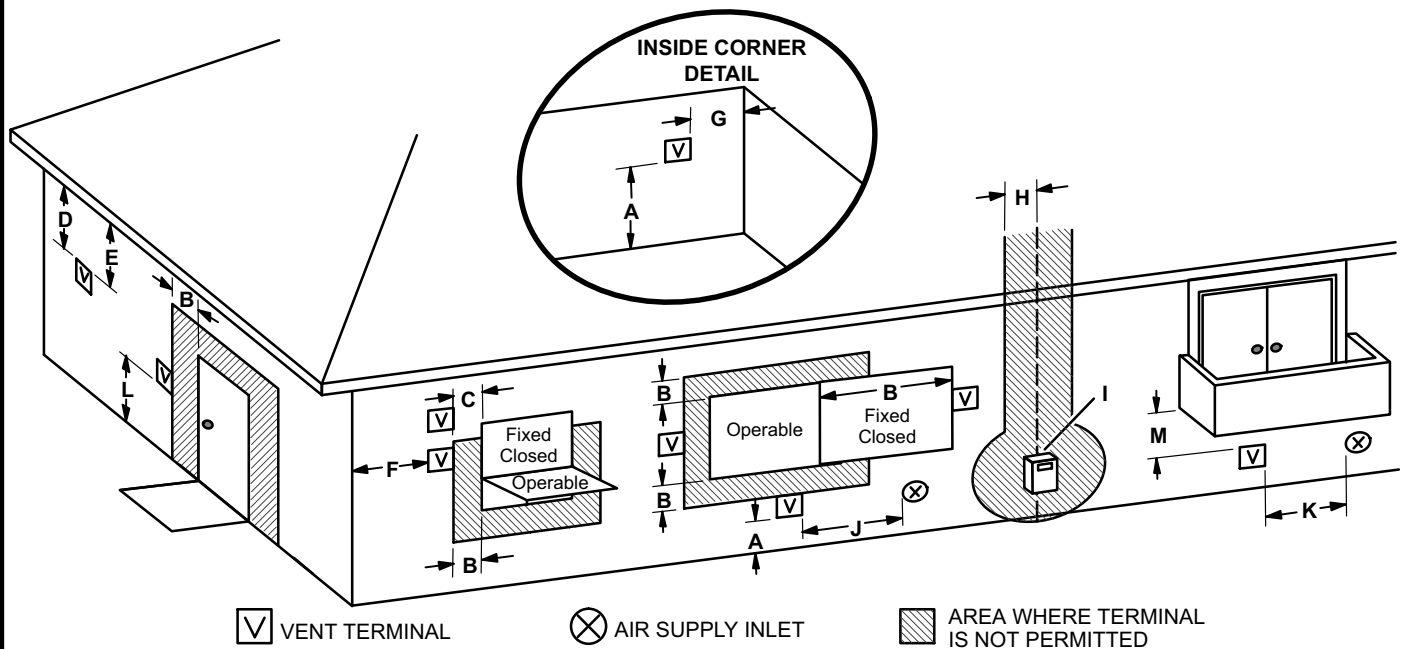

	US Installations ¹	Canadian Installations ²	
A =	Clearance above grade, veranda, porch, deck or balcony	12 inches (305mm) or 12 in. 305mm above average snow accumulation.	12 inches (305mm) or 12 in. 305mm above average snow accumulation.
B =	Clearance to window or door that may be opened	6 inches (152mm) for appliances <10,000 Btuh (3kw), 9 inches (mm) for appliances > 10,000 Btuh (3kw) and <50,000 Btuh (15 kw), 12 inches (305mm) for appliances > 50,000 Btuh (15kw)	6 inches (152mm) for appliances <10,000 Btuh (3kw), 12 inches (305mm) for appliances > 10,000 Btuh (3kw) and <100,000 Btuh (30kw), 36 inches (.9m) for appliances > 100,000 Btuh (30kw)
C =	Clearance to permanently closed window	* 12"	* 12"
D =	Vertical clearance to ventilated soffit located above the terminal within a horizontal distance of 2 feet (mm) from the center line of the terminal	* Equal to or greater than soffit depth	* Equal to or greater than soffit depth
E =	Clearance to unventilated soffit	* Equal to or greater than soffit depth	* Equal to or greater than soffit depth
F =	Clearance to outside corner	* No minimum to outside corner	* No minimum to outside corner
G =	Clearance to inside corner	*	*
H =	Clearance to each side of center line extended above meter / regulator assembly	3 feet (.9m) within a height 15 feet (4.5m) above the meter / regulator assembly	3 feet (.9m) within a height 15 feet (4.5m) above the meter / regulator assembly
I =	Clearance to service regulator vent outlet	* 3 feet (.9m)	3 feet (.9m)
J =	Clearance to non-mechanical air supply inlet to building or the combustion air inlet to any other appliance	6 inches (152mm) for appliances <10,000 Btuh (3kw), 9 inches (mm) for appliances > 10,000 Btuh (3kw) and <50,000 Btuh (15 kw), 12 inches (305mm) for appliances > 50,000 Btuh (15kw)	6 inches (152mm) for appliances <10,000 Btuh (3kw), 12 inches (305mm) for appliances > 10,000 Btuh (3kw) and <100,000 Btuh (30kw), 36 inches (.9m) for appliances > 100,000 Btuh (30kw)
K =	Clearance to mechanical air supply inlet	3 feet (.9m) above if within 10 feet (3m) horizontally	6 feet (1.8m)
L =	Clearance above paved sidewalk or paved driveway located on public property	* 7 feet (2.1m)	7 feet (2.1m)†
M =	Clearance under veranda, porch, deck or balcony	*12 inches (305mm)‡	12 inches (305mm)‡

¹ In accordance with the current ANSI Z223.1/NFPA 54 Natural Fuel Gas Code

² In accordance with the current CSA B149.1, Natural Gas and Propane Installation Code

† A vent shall not terminate directly above a sidewalk or paved driveway that is located between two single family dwellings and serves both dwellings.

‡ Permitted only if veranda, porch, deck or balcony is fully open on a minimum of two sides beneath the floor. Lennox recommends avoiding this location if possible.

*For clearances not specified in ANSI Z223.1/NFPA 54 or CSA B149.1, clearance will be in accordance with local installation codes and the requirements of the gas supplier and these installation instructions."

FIGURE 30

Details of Intake and Exhaust Piping Terminations for Direct Vent Installation

NOTE - In Direct Vent installations, combustion air is taken from outdoors and flue gases are discharged to outdoors.

NOTE - Flue gas may be slightly acidic and may adversely affect some building materials. If any vent termination is used and the flue gasses may impinge on the building material, a corrosion-resistant shield (minimum 24 inches square) should be used to protect the wall surface. If the optional tee is used, the protective shield is recommended. The shield should be constructed using wood, plastic, sheet metal or other suitable material. All seams, joints, cracks, etc. in the affected area should be sealed using an appropriate sealant. See figure 35.

Intake and exhaust pipes may be routed either horizontally through an outside wall or vertically through the roof. In attic or closet installations, vertical termination through the roof is preferred. Figures 31 through 43 show typical terminations.

- 1 - Exhaust and intake exits must be in same pressure zone. Do not exit one through the roof and one on the side. Also, do not exit the intake on one side and the exhaust on another side of the house or structure.
- 2 - Intake and exhaust pipes should be placed as close together as possible at termination end (refer to illustrations). Maximum separation is 3" (76mm) on roof terminations and 6" (152mm) on side wall terminations.
- 3 - On roof terminations, the intake piping should terminate straight down using two 90° elbows (See figure 31).
- 4 - Exhaust piping must terminate straight out or up as shown. A reducer may be required on the exhaust piping at the point where it exits the structure to improve the velocity of exhaust away from the intake piping. See table 8.

NOTE - Care must be taken to avoid recirculation of exhaust back into intake pipe.

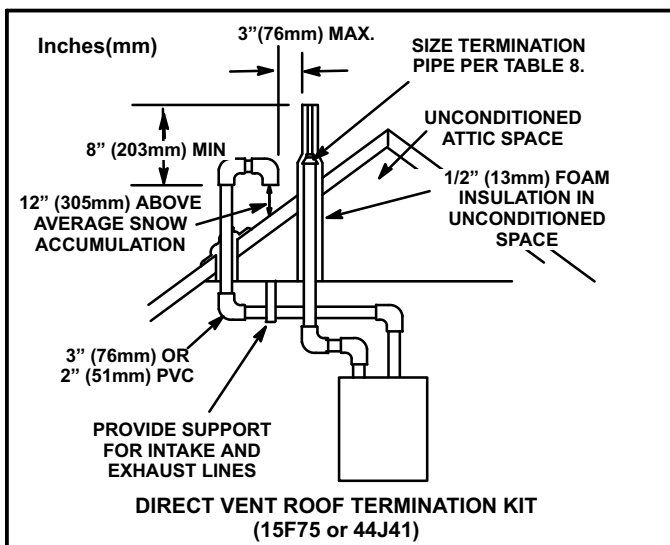

FIGURE 31

FIELD SUPPLIED WALL TERMINATION OR (15F74) WALL RING TERMINATION KIT

NOTE - FIELD PROVIDED REDUCER MAY BE REQUIRED TO ADAPT LARGER VENT PIPE SIZE TO TERMINATION

1/2" (13mm) ARMAFLEX INSULATION IN UNCONDITIONED SPACE

SIZE TERMINATION PER TABLE 8

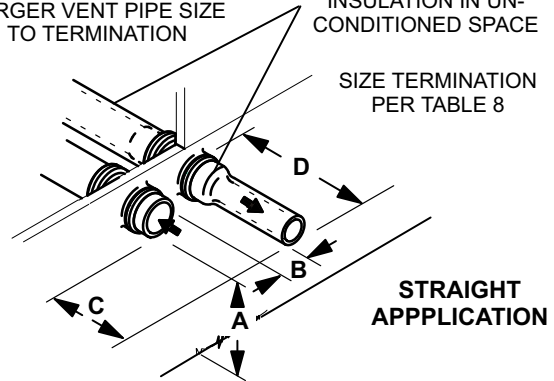

1/2" (13mm) ARMAFLEX INSULATION IN UNCONDITIONED SPACE

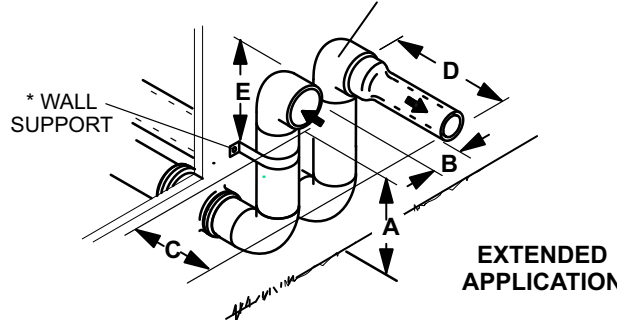

See venting table 7 for maximum venting lengths with this arrangement.

* Use wall support every 24" (610 mm). Use two wall supports if extension is greater than 24" (610 mm) but less than 48" (1219 mm). NOTE - One wall support must be 6" (152 mm) from top of each pipe (intake and exhaust)

	2" (51mm) Vent Pipe	3" (76mm) Vent Pipe
A -Minimum clearance above grade or average snow accumulation	12" (508MM)	12" (508MM)
B -Maximum horizontal separation between intake and exhaust	6" (152MM)	6" (152MM)
C -Minimum from end of exhaust to inlet of intake	8" (203MM)	8" (203MM)
D -Maximum exhaust pipe length	12" (305MM)	20" (508MM)
E -Maximum wall support distance from top of each pipe (intake/exhaust)	6" (152MM)	6" (152MM)

FIGURE 32

FIELD SUPPLIED WALL TERMINATION OR (15F74) WALL RING TERMINATION KIT With INTAKE ELBOW

NOTE - FIELD PROVIDED REDUCER MAY BE REQUIRED TO ADAPT LARGER VENT PIPE SIZE TO TERMINATION

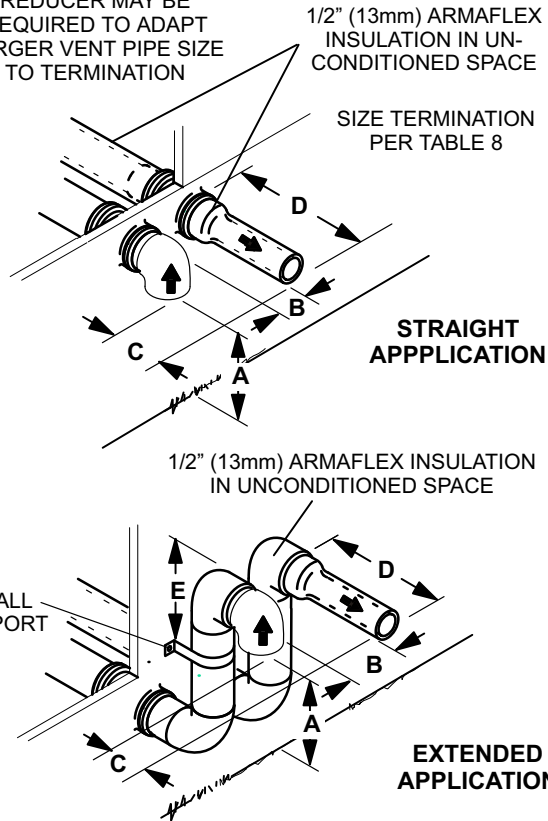

See venting table 7 for maximum venting lengths with this arrangement.

* Use wall support every 24" (610 mm). Use two wall supports if extension is greater than 24" (610 mm) but less than 48" (1219 mm). NOTE - One wall support must be 6" (152 mm) from top of each pipe (intake and exhaust)

	2" (51mm) Vent Pipe	3" (76mm) Vent Pipe
A -Minimum clearance above grade or average snow accumulation	12" (508MM)	12" (508MM)
B -Maximum horizontal separation between intake and exhaust	6" (152MM)	6" (152MM)
C -Minimum from end of exhaust to inlet of intake	6" (152MM)	6" (152MM)
D -Maximum exhaust pipe length	12" (305MM)	20" (508MM)
E -Maximum wall support distance from top of each pipe (intake/exhaust)	6" (152MM)	6" (152MM)

FIGURE 33

TABLE 8 EXHAUST PIPE TERMINATION SIZE REDUCTION

G61MPV MODEL	Exhaust Pipe Size	Termination Pipe Size
045, 070, 071	2" (51mm), 2-1/2" (64mm), 3" (76mm) or 4" (102mm)	1-1/2" (38mm)
090, 091		2" (51mm)
110, 111	3" (76mm) or 4" (102mm)	2" (51mm)
135		2" (51mm)

- On field supplied terminations for side wall exit, exhaust piping may extend a maximum of 12 inches (305mm) for 2" PVC and 20 inches (508mm) for 3" (76mm) PVC beyond the outside wall. Intake piping should be as short as possible. See figures 32 and 33.
- On field supplied terminations, a minimum distance between the end of the exhaust pipe and the end of the intake pipe without a termination elbow is 8" and a minimum distance of 6" with a termination elbow. See figures 32 and 33.
- If intake and exhaust piping must be run up a side wall to position above snow accumulation or other obstructions, piping must be supported every 24" (610mm) as shown in figures 32 and 33. In addition, close coupled wall termination kits must be extended for use in this application. See figures 41 and 42. When exhaust and intake piping must be run up an outside wall, the exhaust piping must be terminated with pipe sized per table 8. The intake piping may be equipped with a 90° elbow turndown. Using turndown will add 5 feet (1.5m) to the equivalent length of the pipe.
- Based on the recommendation of the manufacturer, a multiple furnace installation may use a group of up to four terminations assembled together horizontally, as shown in figure 38.

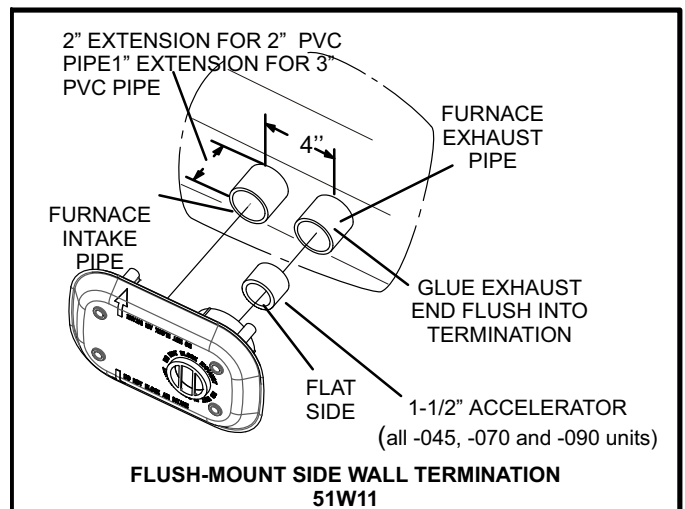

FIGURE 34

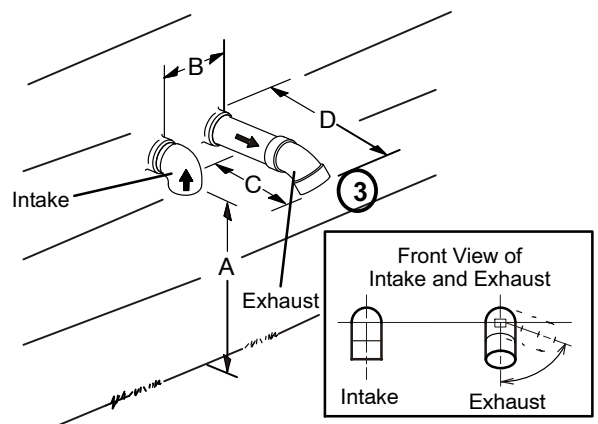
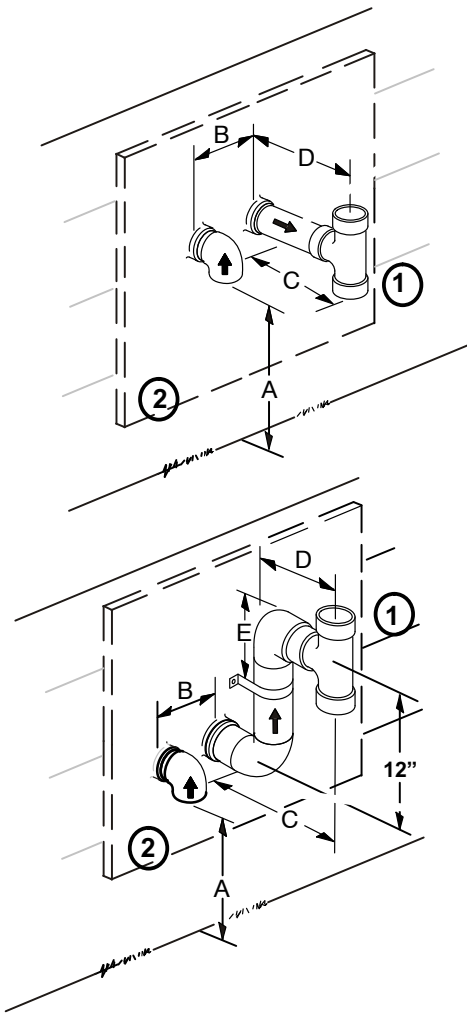

TABLE 9

	2" (51mm) Vent Pipe	3" (76mm) Vent Pipe
A- Clearance above grade or average snow accumulation	12" (508MM) Min.	12" (508MM) Min.
B- Horizontal separation between intake and exhaust	6" (152MM) Min. 24" (610 MM) Max	6" (152MM) Min. 24" (610 MM) Max
C- Minimum from end of exhaust to inlet of intake	9" (227MM) Min.	9" (227MM) Min.
D- Exhaust pipe length	12" (305MM) Min. 16" (405 MM) Max.	12" (305MM) Min. 20" (508MM) Max.
E- Wall support distance from top of each pipe (intake/exhaust)	6" (152MM) Max.	6" (152MM) Max.

¹ The exhaust termination tee should be connected to the 2" or 3" PVC flue pipe as shown in the illustration. Do not use an accelerator in applications that include an exhaust termination tee. The accelerator is not required.

² As required. Flue gas may be acidic and may adversely affect some building materials. If a side wall vent termination is used and flue gases will impinge on the building materials, a corrosion-resistant shield (24 inches square) should be used to protect the wall surface. If optional tee is used, the protective shield is recommended. The shield should be constructed using wood, sheet metal or other suitable material. All seams, joints, cracks, etc. in affected area, should be sealed using an appropriate sealant.

³Exhaust pipe 45° elbow can be rotated to the side away from the combustion air inlet to direct exhaust away from adjacent property. The exhaust must never be directed toward the combustion air inlet.

FIGURE 35

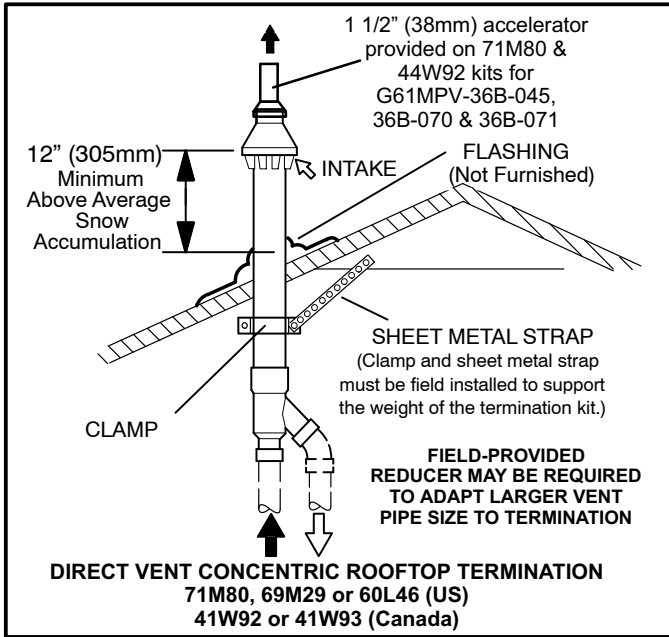

FIGURE 36

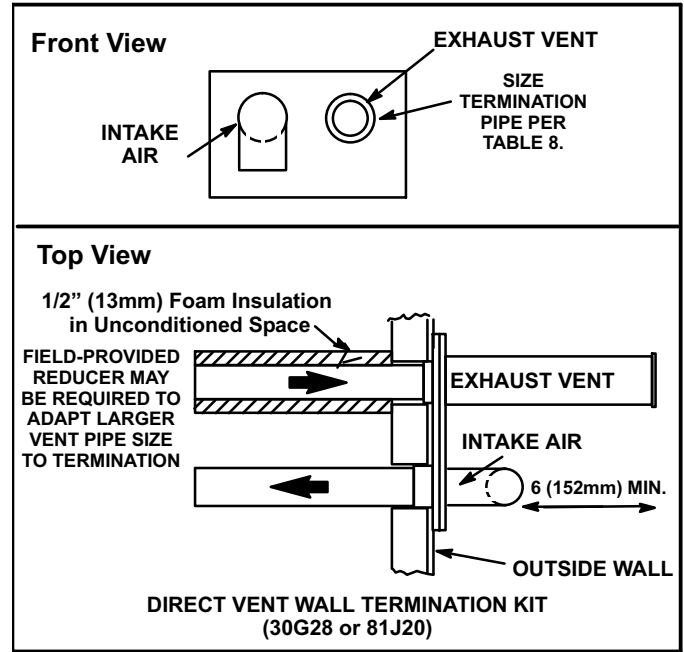

FIGURE 39

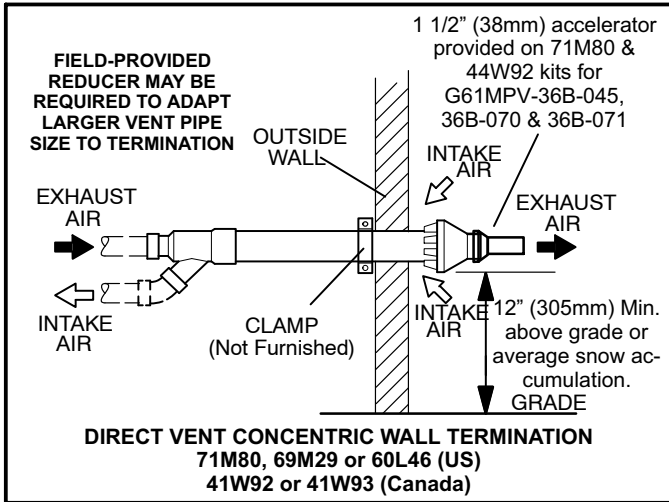

FIGURE 37

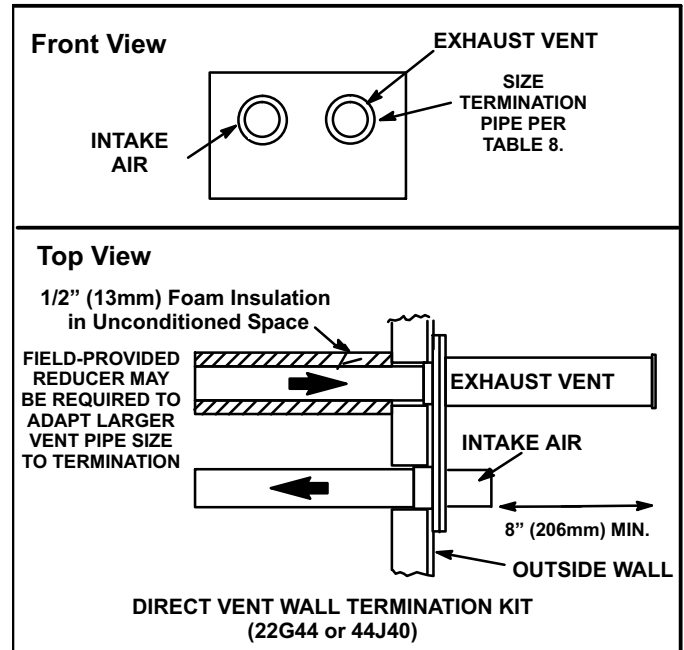

FIGURE 40

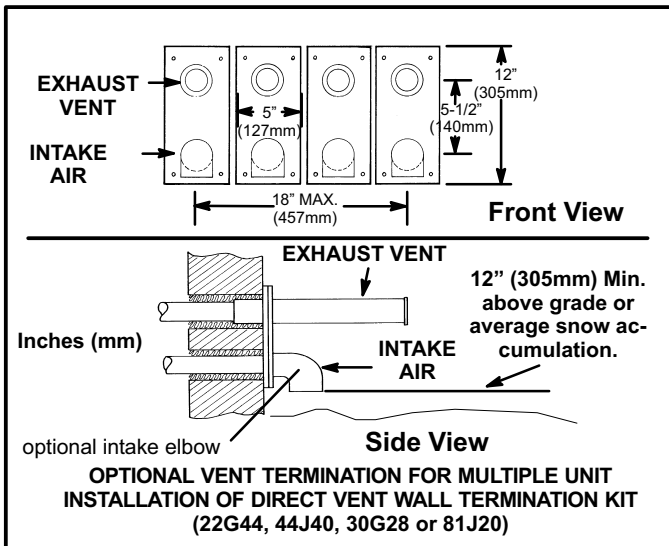
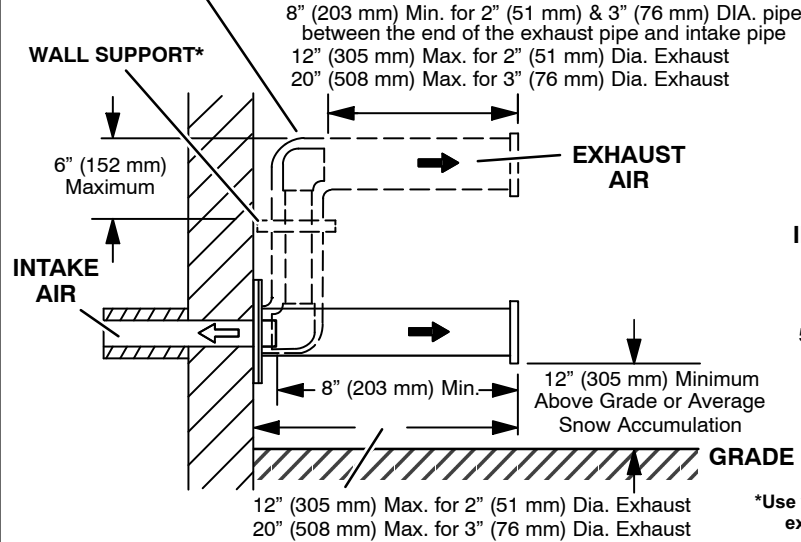

FIGURE 38

**WALL TERMINATION KITS (CLOSE-COUPLE)
EXTENDED VENT FOR GRADE CLEARANCE
2 inch (51 mm) 22G44 (US)
3 inch (76 mm) 44J40 (US)**

If Intake and Exhaust Pipe is less than 12 in. (305 mm) above snow accumulation or other obstructions, field fabricated piping must be installed.



**FIELD-PROVIDED
REDUCER MAY BE REQUIRED TO ADAPT
LARGER VENT PIPE SIZE TO TERMINATION**

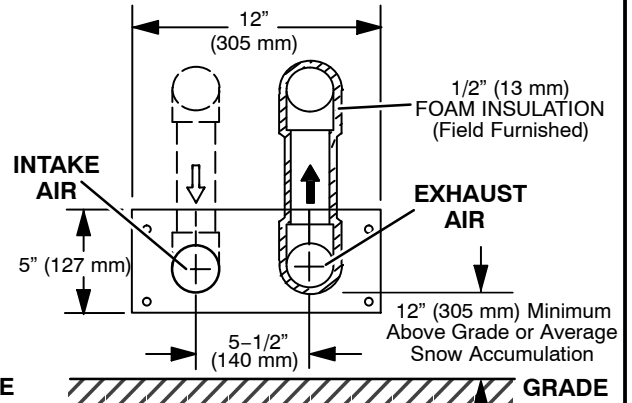

*Use wall support every 24" (610). Use two supports if extension is greater than 24" but less than 48".

FIGURE 41

**WALL TERMINATION KITS (CLOSE-COUPLE)
EXTENDED VENT FOR GRADE CLEARANCE
2 inch (51 mm) 30G28 (WTK Canada)
3 inch (76 mm) 81J20 (WTK Canada)**

See Installation Instructions for additional information.

If Intake and Exhaust Pipe is less than 12 in. (305 mm) above snow accumulation or other obstructions, field fabricated piping must be installed.

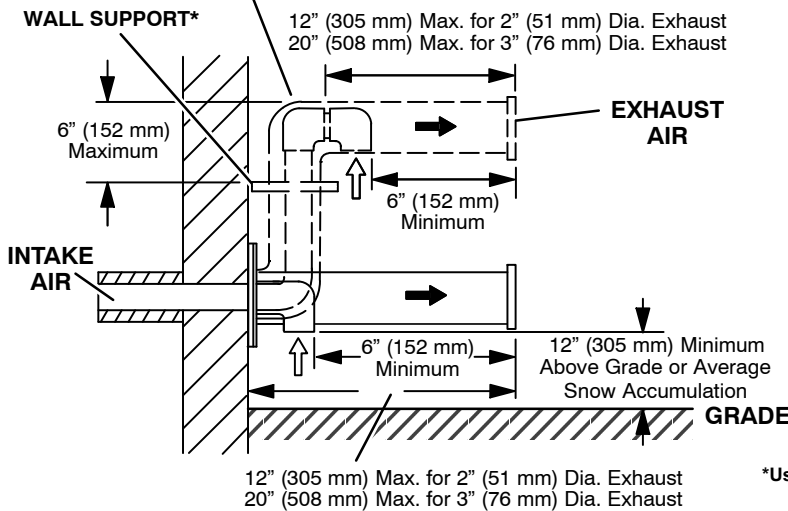

**FIELD-PROVIDED
REDUCER MAY BE REQUIRED TO ADAPT
LARGER VENT PIPE SIZE TO TERMINATION**

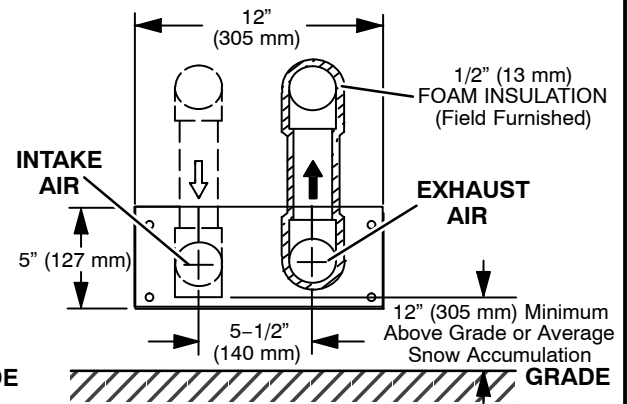

*Use wall support every 24" (610). Use two supports if extension is greater than 24" but less than 48".

FIGURE 42

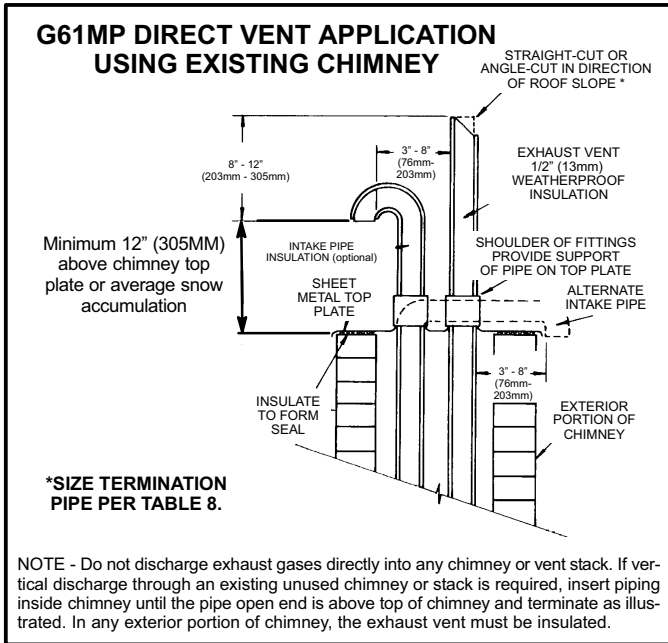

FIGURE 43

Details of Exhaust Piping Terminations for Non-Direct Vent Applications

Exhaust pipes may be routed either horizontally through an outside wall or vertically through the roof. In attic or closet installations, vertical termination through the roof is preferred. Figures 44 through 47 show typical terminations.

- 1 - Exhaust piping must terminate straight out or up as shown. The termination pipe must be sized as listed in table 8. The specified pipe size ensures proper velocity required to move the exhaust gases away from the building.
- 2 - On field supplied terminations for side wall exit, exhaust piping may extend a maximum of 12 inches (305mm) for 2" PVC and 20 inches (508mm) for 3" (76mm) PVC beyond the outside wall. See figure 45.

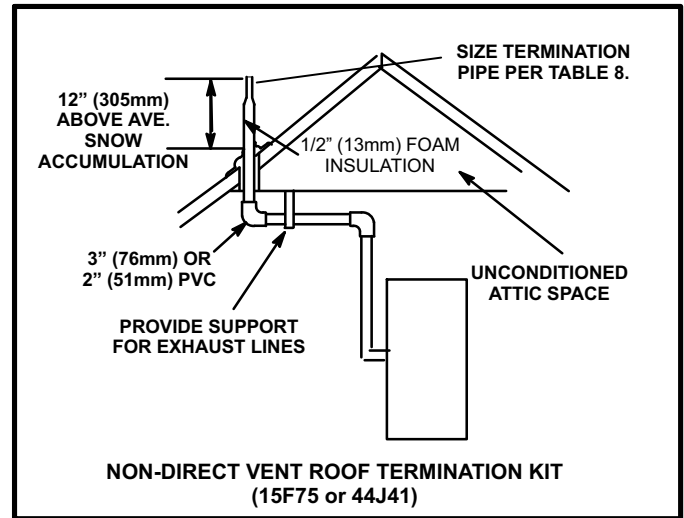

FIGURE 44

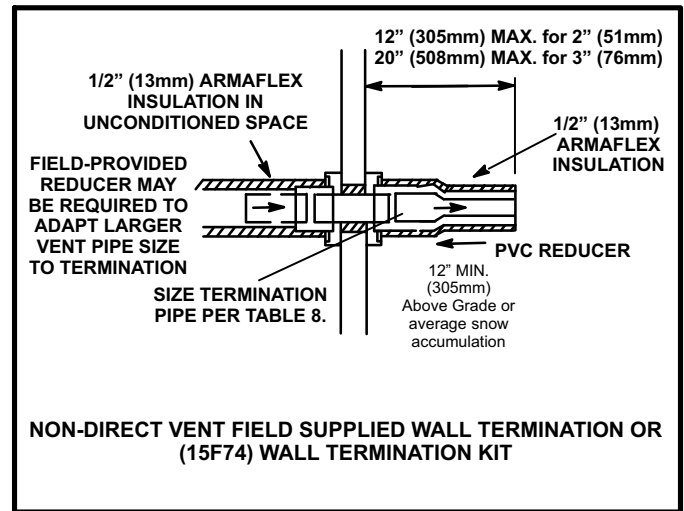

FIGURE 45

- 3 - If exhaust piping must be run up a side wall to position above snow accumulation or other obstructions, piping must be supported every 24 inches (610mm) as shown in figure 46. When exhaust piping must be run up an outside wall, any reduction in exhaust pipe size must be done after the final elbow.

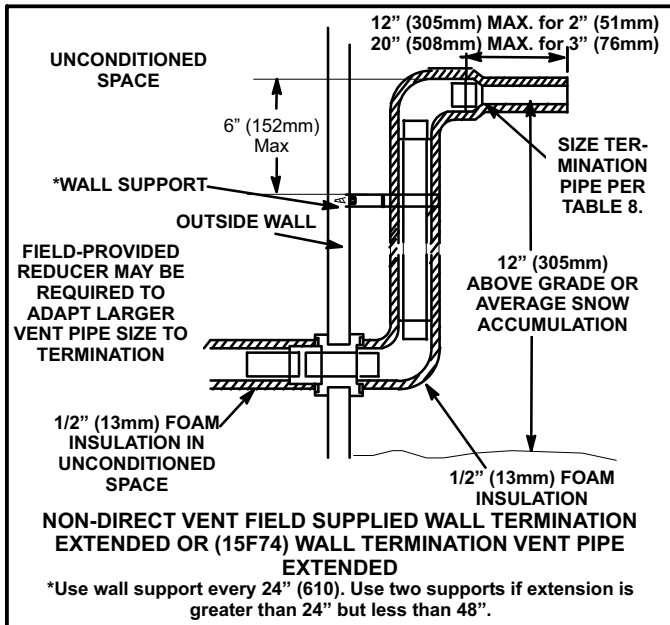

FIGURE 46

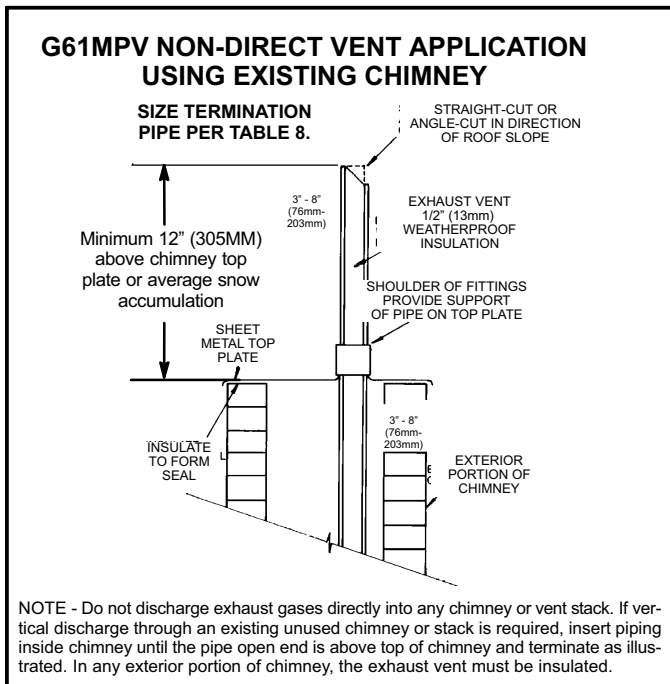

FIGURE 47

Condensate Piping

This unit is designed for either right- or left-side exit of condensate piping in either upflow or downflow applications; however, it must be installed on the same side of the unit as the exhaust piping. In horizontal applications, the condensate trap should extend below the unit. A 5-1/2" service clearance is required for the condensate trap. Refer to figure 48 for condensate trap locations.

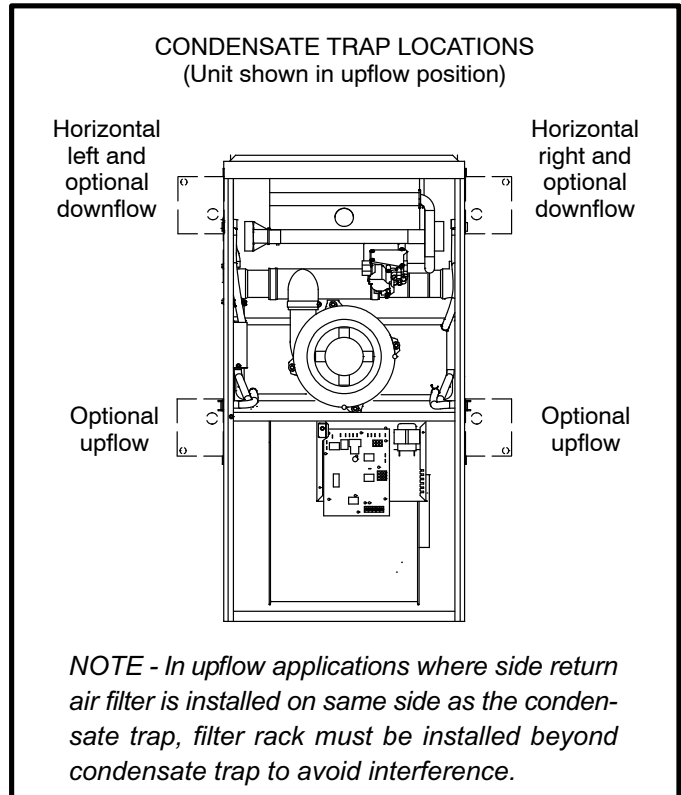

FIGURE 48

- 1 - Determine which side condensate piping will exit the unit. Remove plugs from the condensate collar at the appropriate location on the side of the unit.

NOTE - The condensate trap is factory-shipped with two rubber O-rings and two rubber clean-out caps installed. Check to make sure that these items are in place before installing the trap assembly.

- 2 - Install condensate trap onto the condensate collar. Use provided HI/LO screws to secure two upper flanges of the trap to the collar. Use provided sheet metal screw to secure bottom trap flange to side of unit. **DO NOT apply glue to secure condensate trap to cabinet.** All other joints must be glued. See figure 49.

NOTE - In upflow and downflow applications, condensate trap must be installed on the same side as exhaust piping.

⚠ CAUTION

DO NOT use a power driver to tighten screws which secure condensate trap to cabinet. Screws should be hand-tightened using a screw driver to avoid the possibility of damage to the trap assembly.

- 3 - The condensate trap provided with the unit is manufactured using ABS material. Use ABS to PVC transition solvent cement to glue a field-provided PVC coupling or PVC pipe to the trap. Install a tee and vent pipe near the trap.

NOTE - The condensate trap drain stubs (both sides) have an outer diameter which will accept a standard 3/4" PVC coupling. The inner diameter of each stub will accept standard 1/2" diameter PVC pipe.

NOTE - Vinyl tubing may be used for condensate drain. Tubing must be 1-1/4" OD X 1" ID and should be attached to the drain stubs on the trap using a hose clamp.

- 4 - Glue the field-provided drain line to the tee. Route the drain line to an open drain. As an alternate, clear vinyl tubing may be used to drain condensate away from the trap. Secure the vinyl tubing to the drain stubs on the trap using a hose clamp. Do not overtighten the hose clamp.

Condensate line must be sloped downward away from condensate trap to drain. If drain level is above condensate trap, condensate pump must be used. Condensate drain line should be routed within the conditioned space to avoid freezing of condensate and blockage of drain line. If this is not possible, a heat cable kit may be used on the condensate trap and line. Heating cable kit is available from Lennox in various lengths; 6 ft. (1.8m) - kit no. 26K68; 24 ft. (7.3m) - kit no. 26K69; and 50 ft. (15.2m) - kit no. 26K70.

- 5 - If unit will be started immediately upon completion of installation, prime trap per procedure outlined in Unit Start-Up section.
- 6 - Glue the provided cap onto the unused condensate drain line stub.

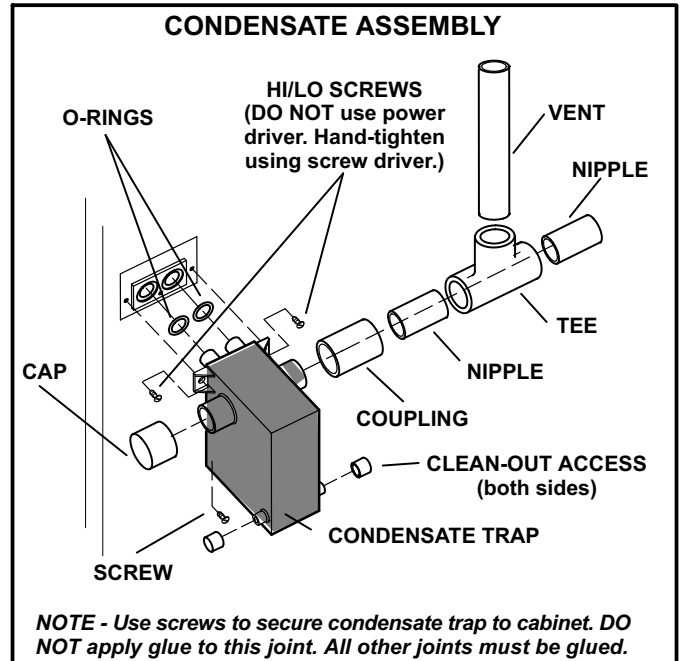

FIGURE 49

CAUTION
Do not use copper tubing or existing copper condensate lines for drain line.

Gas Piping

⚠ CAUTION

If a flexible gas connector is required or allowed by the authority that has jurisdiction, black iron pipe shall be installed at the gas valve and extend outside the furnace cabinet.

⚠ WARNING

Do not exceed 600 in-lbs (50 ft-lbs) torque when attaching the gas piping to the gas valve.

- 1 - Gas piping may be routed into the unit through either the left- or right-hand side. Supply piping enters into the gas valve from the side of the valve as shown in figures 51 and 52.
- 2 - When connecting gas supply, factors such as length of run, number of fittings and furnace rating must be considered to avoid excessive pressure drop. Table 10 lists recommended pipe sizes for typical applications.
NOTE - Use two wrenches when connecting gas piping to avoid transferring torque to the manifold.
- 3 - Gas piping must not run in or through air ducts, clothes chutes, chimneys or gas vents, dumb waiters or elevator shafts. Center gas line through piping hole. Gas line should not touch side of unit. See figures 51 and 52.
- 4 - Piping should be sloped 1/4 inch per 15 feet (6mm per 5.6m) upward toward the gas meter from the furnace. The piping must be supported at proper intervals, every 8 to 10 feet (2.44 to 3.05m), using suitable hangers or straps. Install a drip leg in vertical pipe runs to serve as a trap for sediment or condensate.
- 5 - A 1/8" N.P.T. plugged tap or pressure post is located on the gas valve to facilitate test gauge connection. See figures 59 and 60.
- 6 - In some localities, codes may require installation of a manual main shut-off valve and union (furnished by installer) external to the unit. Union must be of the ground joint type.

⚠ IMPORTANT

Compounds used on threaded joints of gas piping must be resistant to the actions of liquified petroleum gases.

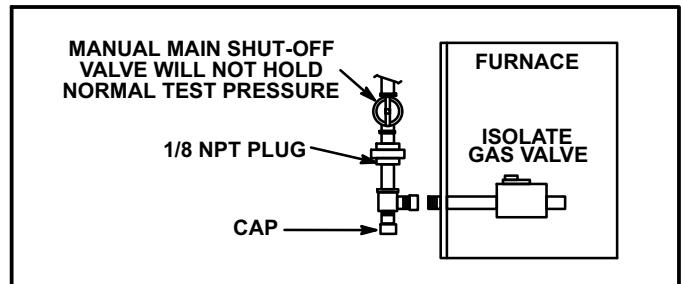

FIGURE 50

Leak Check

After gas piping is completed, carefully check all piping connections (factory- and field-installed) for gas leaks. Use a leak detecting solution or other preferred means.

The furnace must be isolated from the gas supply system by closing its individual manual shut-off valve during any pressure testing of the gas supply system at pressures less than or equal to 1/2 psig (3.48 kPa, 14 inches w.c.).

⚠ IMPORTANT

When testing gas lines using pressures in excess of 1/2 psig (3.48 kPa), gas valve must be disconnected and isolated. See figure 50. Gas valves can be damaged if subjected to pressures greater than 1/2 psig (3.48 kPa).

⚠ WARNING

FIRE OR EXPLOSION HAZARD

Failure to follow the safety warnings exactly could result in serious injury, death, or property damage. Never use an open flame to test for gas leaks. Check all connections using a commercially available soap solution made specifically for leak detection. Some soaps used for leak detection are corrosive to certain metals. Carefully rinse piping thoroughly after leak test has been completed.

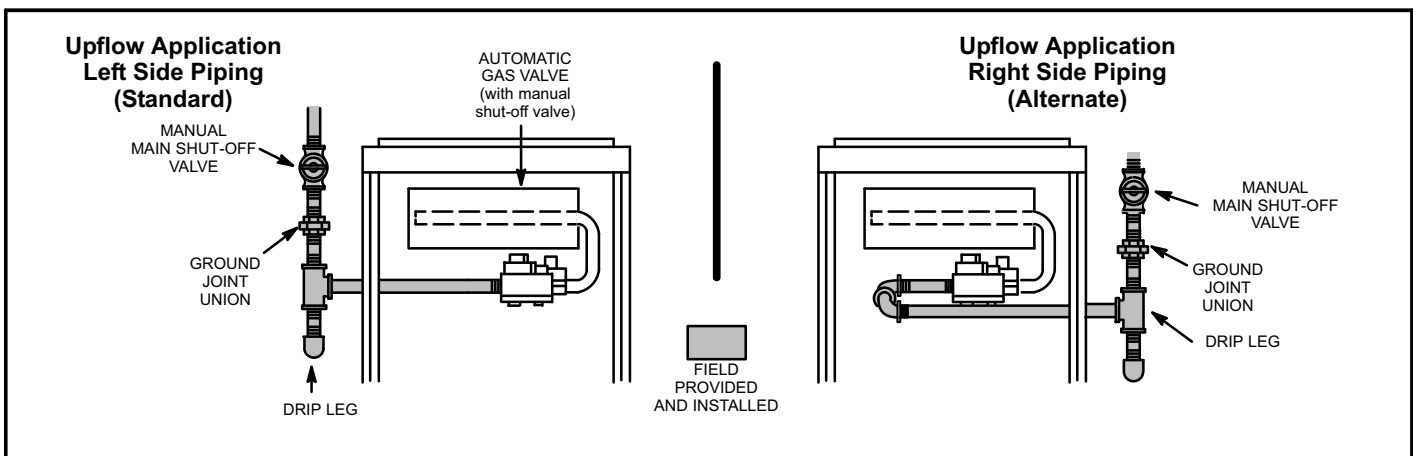

FIGURE 51

**Horizontal Applications
Possible Gas Piping Configurations**

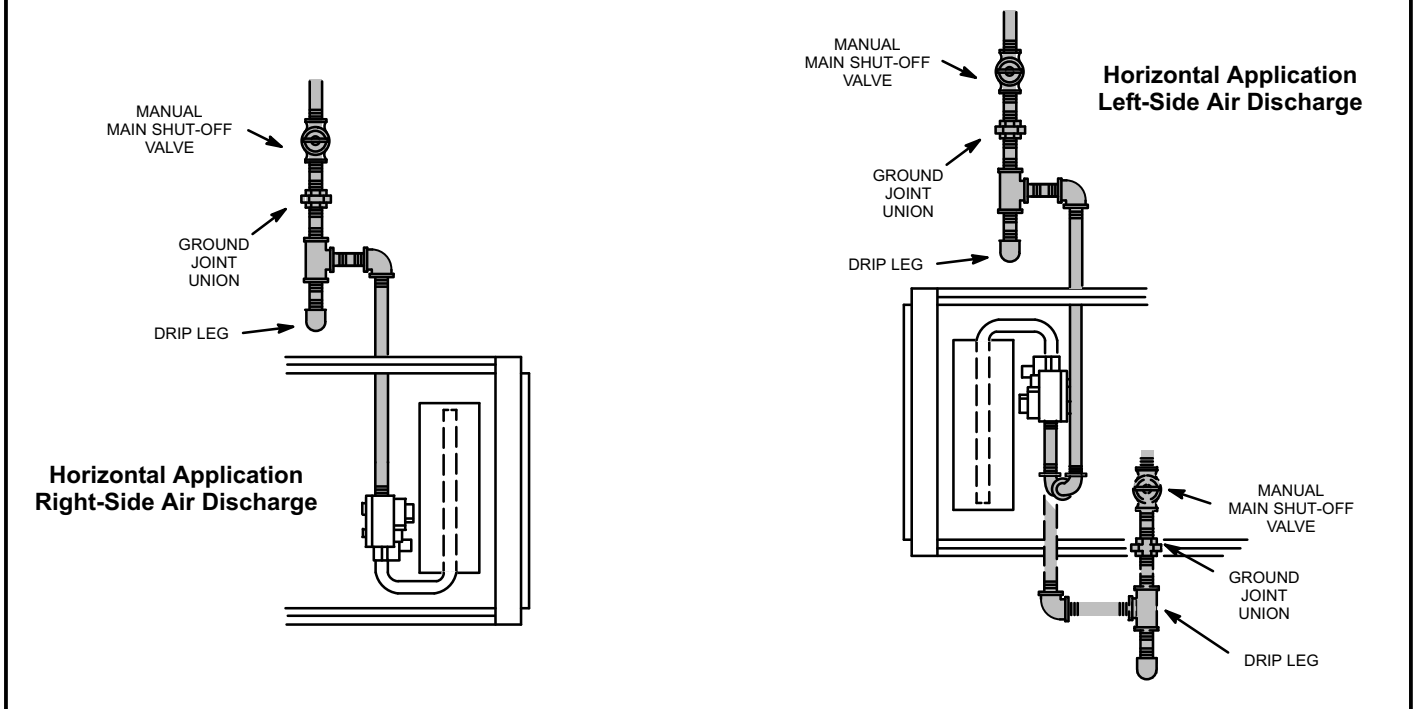

FIGURE 52

**TABLE 10
GAS PIPE CAPACITY - FT³/HR (kL/HR)**

Nominal Iron Pipe Size -Inches(mm)	Internal Diameter -Inches(mm)	Length of Pipe-Feet(m)									
		10 (3.048)	20 (6.096)	30 (9.144)	40 (12.192)	50 (15.240)	60 (18.288)	70 (21.336)	80 (24.384)	90 (27.432)	100 (30.480)
1/4 (6.35)	.364 (9.246)	43 (1.13)	29 (.82)	24 (.68)	20 (.57)	18 (.51)	16 (.45)	15 (.42)	14 (.40)	13 (.37)	12 (.34)
3/8 (9.53)	.493 (12.522)	95 (2.69)	65 (1.84)	52 (1.47)	45 (1.27)	40 (1.13)	36 (1.02)	33 (.73)	31 (.88)	29 (.82)	27 (.76)
1/2 (12.7)	.622 (17.799)	175 (4.96)	120 (3.40)	97 (2.75)	82 (2.32)	73 (2.07)	66 (1.87)	61 (1.73)	57 (1.61)	53 (1.50)	50 (1.42)
3/4 (19.05)	.824 (20.930)	360 (10.19)	250 (7.08)	200 (5.66)	170 (4.81)	151 (4.28)	138 (3.91)	125 (3.54)	118 (3.34)	110 (3.11)	103 (2.92)
1 (25.4)	1.049 (26.645)	680 (19.25)	465 (13.17)	375 (10.62)	320 (9.06)	285 (8.07)	260 (7.36)	240 (6.80)	220 (6.23)	205 (5.80)	195 (5.52)
1-1/4 (31.75)	1.380 (35.052)	1400 (39.64)	950 (26.90)	770 (21.80)	660 (18.69)	580 (16.42)	530 (15.01)	490 (13.87)	460 (13.03)	430 (12.18)	400 (11.33)
1-1/2 (38.1)	1.610 (40.894)	2100 (59.46)	1460 (41.34)	1180 (33.41)	990 (28.03)	900 (25.48)	810 (22.94)	750 (21.24)	690 (19.54)	650 (18.41)	620 (17.56)
2 (50.8)	2.067 (52.502)	3950 (111.85)	2750 (77.87)	2200 (62.30)	1900 (53.80)	1680 (47.57)	1520 (43.04)	1400 (39.64)	1300 (36.81)	1220 (34.55)	1150 (32.56)
2-1/2 (63.5)	2.469 (67.713)	6300 (178.39)	4350 (123.17)	3520 (99.67)	3000 (84.95)	2650 (75.04)	2400 (67.96)	2250 (63.71)	2050 (58.05)	1950 (55.22)	1850 (52.38)
3 (76.2)	3.068 (77.927)	11000 (311.48)	7700 (218.03)	6250 (176.98)	5300 (150.07)	4750 (134.50)	4300 (121.76)	3900 (110.43)	3700 (104.77)	3450 (97.69)	3250 (92.03)
4 (101.6)	4.026 (102.260)	23000 (651.27)	15800 (447.39)	12800 (362.44)	10900 (308.64)	9700 (274.67)	8800 (249.18)	8100 (229.36)	7500 (212.37)	7200 (203.88)	6700 (189.72)

NOTE - Capacity given in cubic feet of gas per hour (kilo liters of gas per hour) and based on 0.60 specific gravity gas.

Electrical

ELECTROSTATIC DISCHARGE (ESD)

Precautions and Procedures

⚠ CAUTION

Electrostatic discharge can affect electronic components. Take precautions during furnace installation and service to protect the furnace's electronic controls. Precautions will help to avoid control exposure to electrostatic discharge by putting the furnace, the control and the technician at the same electrostatic potential. Neutralize electrostatic charge by touching hand and all tools on an unpainted unit surface, such as the gas valve or blower deck, before performing any service procedure.

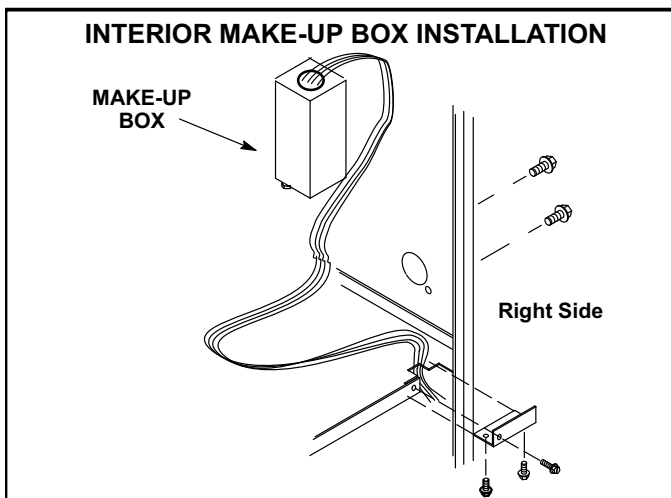

FIGURE 53

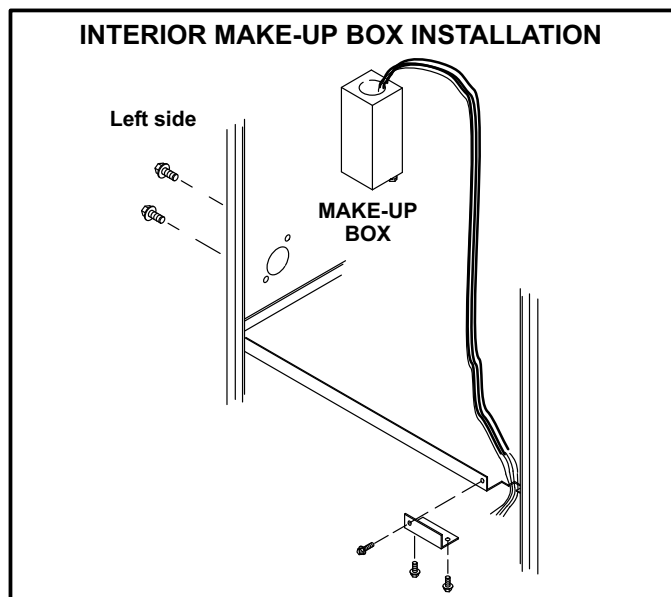

FIGURE 54

The unit is equipped with a field make-up box. The make-up box may be moved to the right side of the furnace to facilitate installation. If the make-up box is moved to the right side, the excess wire must be pulled into the blower compartment. Secure the excess wire to the existing harness to protect it from damage.

Refer to figure 55 and table 11 for field wiring and figure 58 for schematic wiring diagram and troubleshooting.

- 1 - The power supply wiring must meet Class I restrictions. Protected by either a fuse or circuit breaker, select circuit protection and wire size according to unit nameplate.

NOTE - Unit nameplate states maximum current draw. Maximum Over-Current Protection allowed is 20AMP.

- 2 - Holes are on both sides of the furnace cabinet to facilitate wiring.
- 3 - Install a separate (properly sized) disconnect switch near the furnace so that power can be turned off for servicing.
- 4 - Before connecting the thermostat or the power wiring, check to make sure the wires will be long enough for servicing at a later date. Remove the blower access panel to check the length of the wire.
- 5 - Complete the wiring connections to the equipment. Use the provided unit wiring diagram and the field wiring diagram shown in figure 55 and table 11. Use 18-gauge wire or larger that is suitable for Class II rating for thermostat connections.

NOTE - Do NOT make a wire connection between the room thermostat L terminal and the L terminal of the G61MPV integrated control.

- 6 - Electrically ground the unit according to local codes or, in the absence of local codes, according to the current National Electric Code (ANSI/NFPA No. 70) for the USA and current Canadian Electric Code part 1 (CSA standard C22.1) for Canada. A green ground wire is provided in the field make-up box.

NOTE - The G61MPV furnace contains electronic components that are polarity sensitive. Make sure that the furnace is wired correctly and is properly grounded.

- 7 - One line voltage "EAC" 1/4" spade terminal is provided on the furnace control board. Any electronic air cleaner rated up to one amp can be connected to this terminal with the neutral leg of the circuit being connected to one of the provided neutral terminals. See figure 56 for control board configuration. This terminal is energized when the indoor blower is operating.
- 8 - One line voltage "HUM" 1/4" spade terminal is provided on the furnace control board. Any humidifier rated up to one amp can be connected to this terminal with the neutral leg of the circuit being connected to one of the

provided neutral terminals. See figure 56 for control board configuration. This terminal is energized in the heating mode when the combustion air inducer is operating.

- 9 - One 24V "H" terminal is provided on the furnace control board terminal block. Any humidifier rated up to 0.5 amp can be connected to this terminal with the ground leg of the circuit being connected to either ground or the "C" terminal. See figure 56 for control board configuration.
- 10 - Install the room thermostat according to the instructions provided with the thermostat. See table 11 for thermostat connections. If the furnace is being

matched with a heat pump, refer to the instruction packaged with the dual fuel thermostat.

Indoor Blower Speeds

- 1 - When the thermostat is set to "FAN ON," the indoor blower will run continuously at approximately 38% of the second-stage cooling speed when there is no cooling or heating demand.
- 2 - When the G61MPV is running in the heating mode, the indoor blower will run on the heating speed designated by the positions of DIP switches 11 and 12.
- 3 - When there is a cooling demand, the indoor blower will run on the cooling speed designated by the positions of DIP switches 5 and 6.

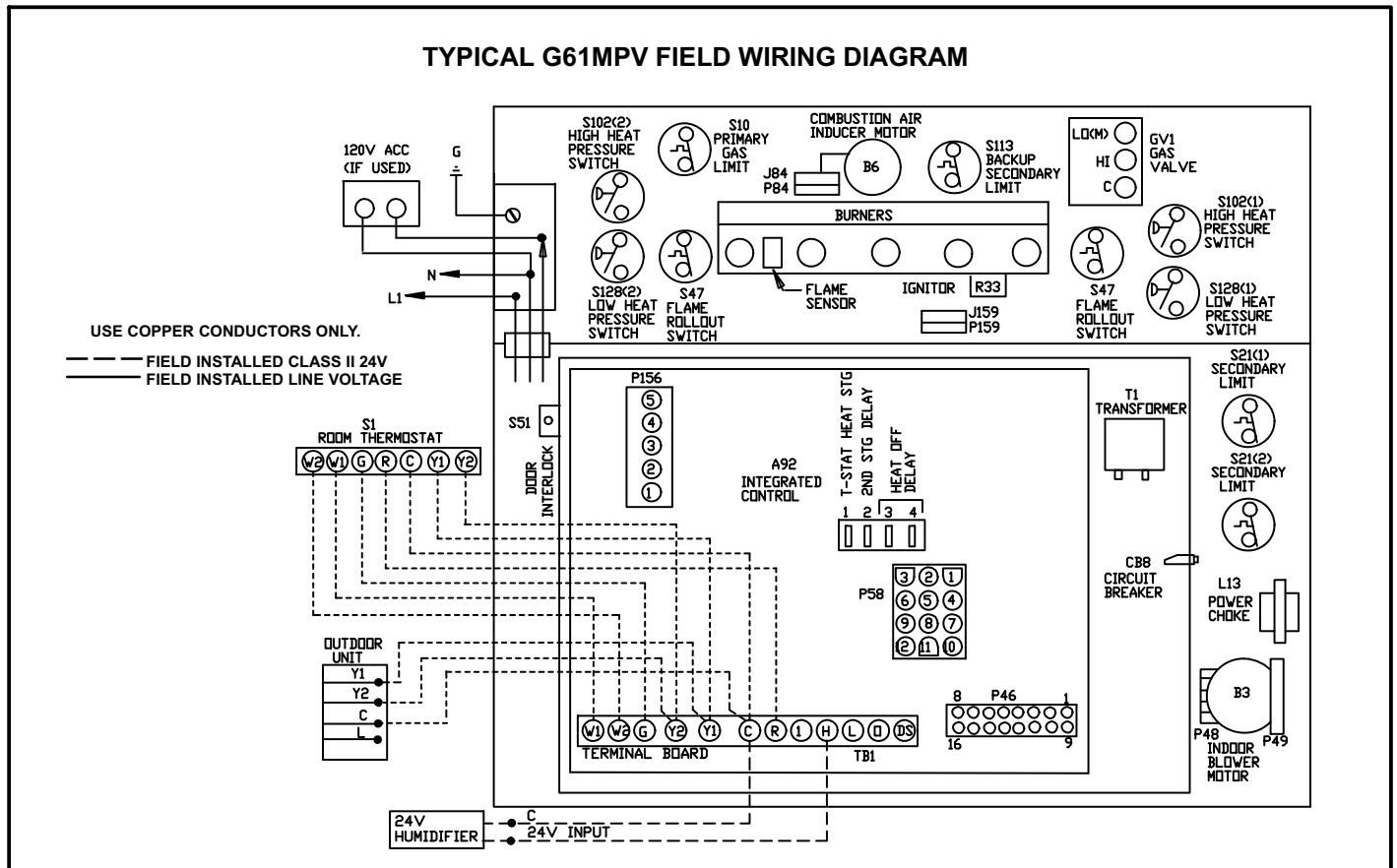

FIGURE 55

TABLE 11
Field Wiring Applications

Thermostat	Dip Switch Settings and On Board Links (See figure 56)				Wiring Connections
	DIP Switch 1	W915 Two-Stage Cooling	W914 Dehumidification or Harmony III™	W951 Heat Pumps	
1Heat / 1 Cool <i>NOTE - Use DIP switch 2 to set second-stage heat ON delay. OFF-10 minutes. ON-15 minutes.</i>	ON	Intact	Intact	Intact	
1 Heat / 2 Cool <i>NOTE - Use DIP switch 2 to set second-stage heat ON delay. OFF-10 minutes. ON-15 minutes.</i>	ON	Cut	Intact	Intact	
1 Heat / 2 Cool with t'stat with humidity control <i>NOTE - Use DIP switch 2 to set second-stage heat ON delay. OFF-10 minutes. ON-15 minutes.</i>	ON	Cut	Cut	Intact	

TABLE 11
Field Wiring Applications (Continued)

Thermostat	Dip Switch Settings and On Board Links (See figure 56)				Wiring Connections
	DIP Switch 1	W915 Two-Stage Cooling	W914 Dehumidification or Harmony III™	W951 Heat Pumps	
2 Heat / 2 Cool	OFF	Cut	Intact	Intact	
2 Heat / 2 Cool with t'stat with humidity control	OFF	Cut	Cut	Intact	
2 Heat / 1 Cool	OFF	Intact	Intact	Intact	

TWO-STAGE, VARIABLE SPEED INTEGRATED CONTROL BOARD

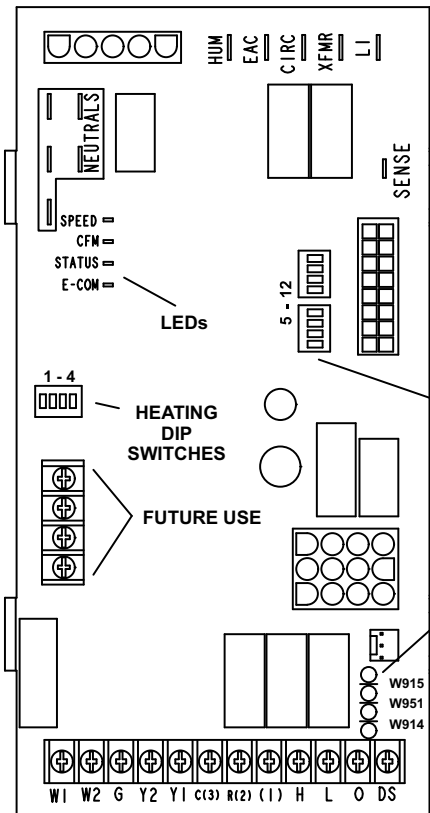

1/4" QUICK CONNECT TERMINALS

HUM = 120 VAC OUTPUT TO HUMIDIFIER
 XMFR = 120 VAC OUTPUT TO TRANSFORMER
 LI = 120 VAC INPUT TO CONTROL
 CIRC = 120 VAC OUTPUT TO CIRCULATING BLOWER
 EAC = 120 VAC OUTPUT TO ELECTRONIC AIR CLEANER
 NEUTRALS= 120 VAC NEUTRAL

THERMOSTAT CONNECTIONS (TB1)

DS= DEHUMIDIFICATION SIGNAL
 W2= HEAT DEMAND FROM 2ND STAGE T'STAT
 W1= HEAT DEMAND FROM 1ST STAGE T'STAT
 R= CLASS 2 VOLTAGE TO THERMOSTAT
 G= MANUAL FAN FROM T'STAT
 C= THERMOSTAT SIGNAL GROUND CONNECTED TO TRANSFORMER GROUND (TR) & CHASSIS GROUND (GRD)
 Y1= THERMOSTAT 1st STAGE COOL SIGNAL
 Y2= THERMOSTAT 2nd STAGE COOL SIGNAL
 O= THERMOSTAT SIGNAL TO HEAT PUMP REVERSING VALVE
 H= 24V HUMIDIFIER OUTPUT
 L= DO NOT USE
 1= FUTURE USE

DIP SWITCH FUNCTIONS

HTG DIP SWITCH(ES)	FUNCTION
1	T'stat Heat Stages (single or two-stage)
2	Second Stage ON Delay (single-stage t'stat)
3 and 4	Heating Fan OFF Delay
INDOOR BLOWER DIP SWITCH(ES)	
5 and 6	Cooling Mode Blower Speed
7 and 8	Blower Speed Adjustment
9 and 10	Cooling Mode Blower Ramping Profile
11 and 12	Heating Mode Blower Speed

FIGURE 56

INTEGRATED CONTROL BOARD DIP SWITCH SETTINGS AND JUMPERS

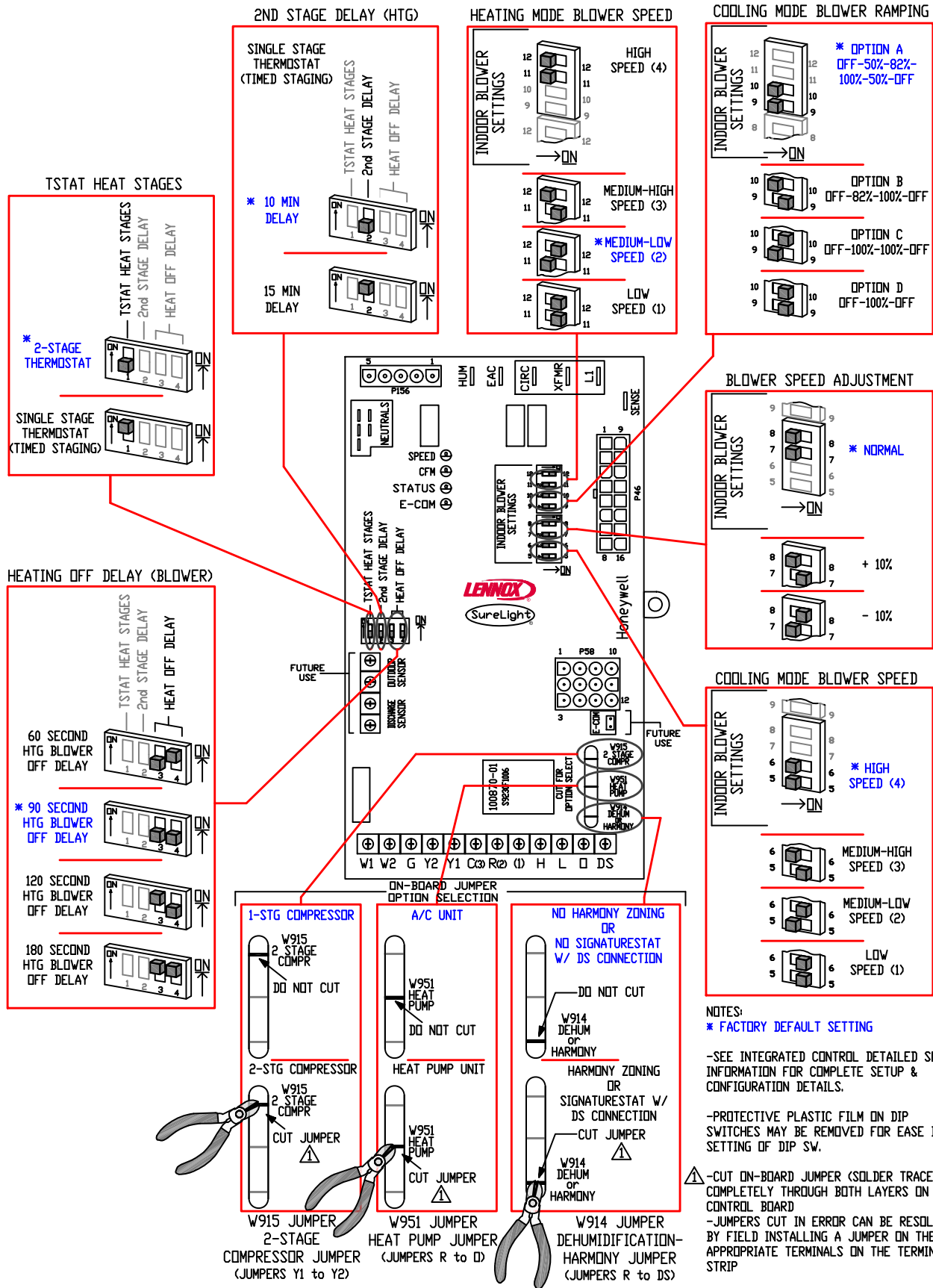

FIGURE 57

TYPICAL G61MPV WIRING DIAGRAM

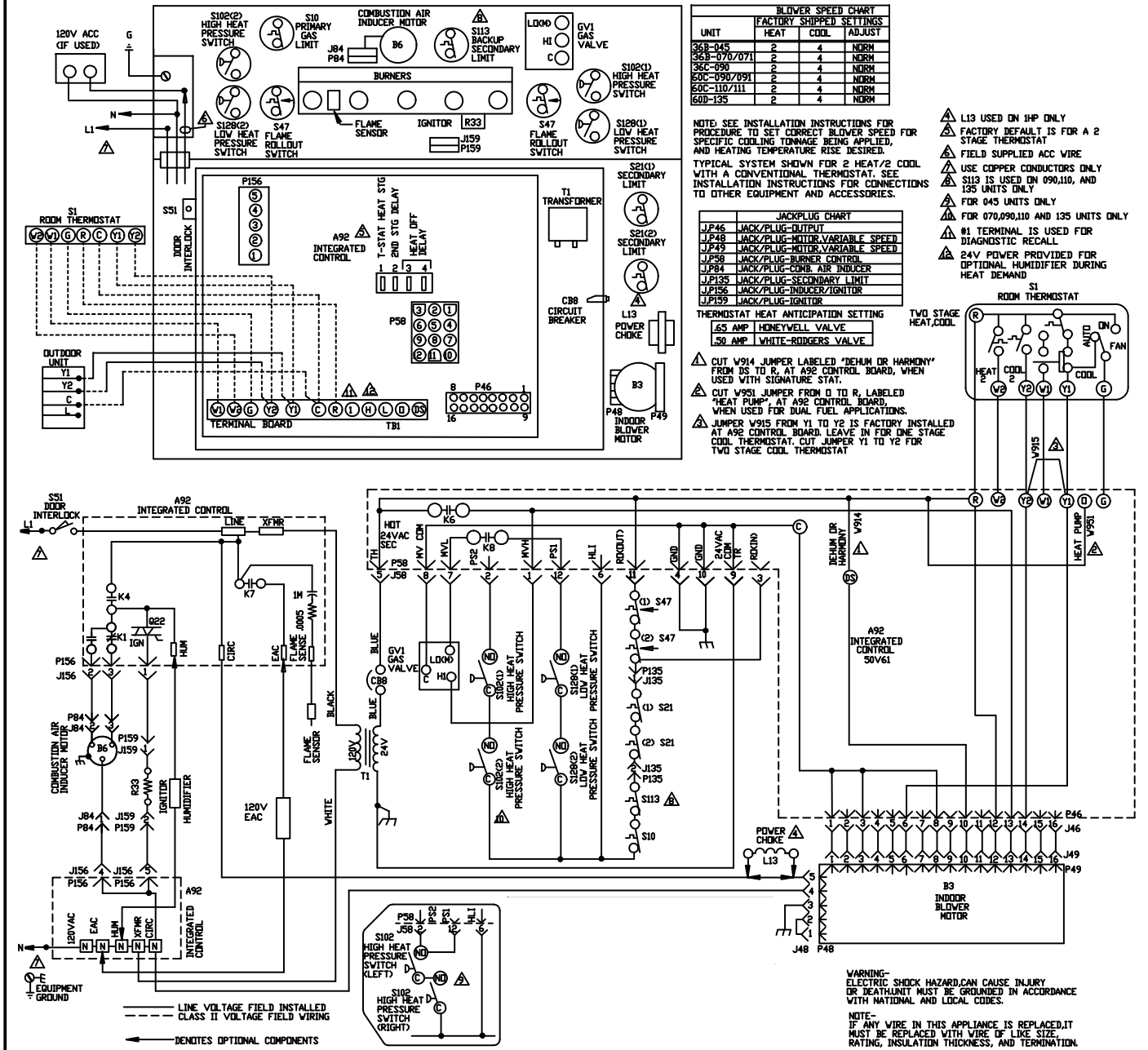

FIGURE 58

Integrated Control Board

G61MPV units are equipped with a two-stage, variable speed integrated control. This control manages ignition timing, heating mode fan off delays and indoor blower speeds based on selections made using the control dip switches and jumpers. The control includes an internal watchdog feature which automatically resets the ignition control when it has been locked out. After one hour of continuous thermostat demand for heat, the watchdog will break and remake thermostat demand to the furnace and automatically reset the control to relight the furnace.

Heating Operation DIP Switch Settings -- Figure 57

Switch 1 -- Thermostat Selection -- This unit may be used with either a single-stage or two-stage thermostat. The thermostat selection is made using a DIP switch which must be properly positioned for the particular application. The DIP switch is factory-positioned for use with a two-stage thermostat. If a single-stage thermostat is to be used, the DIP switch must be repositioned.

- a - Select "OFF" for two-stage heating operation controlled by a two-stage heating thermostat (factory setting);
- b - Select "ON" for two-stage heating operation controlled by a single-stage heating thermostat. This setting provides a timed delay before second-stage heat is initiated.

Switch 2 -- Second Stage Delay (Used with Single-Stage Thermostat Only) -- This switch is used to determine the second stage on delay when a single-stage thermostat is being used. The switch is factory-set in the OFF position, which provides a 10-minute delay before second-stage heat is initiated. If the switch is toggled to the ON position, it will provide a 15-minute delay before second-stage heat is initiated. This switch is only activated when the thermostat selector jumper is positioned for SINGLE-stage thermostat use.

Switches 3 and 4 -- Blower-Off Delay -- The blower-on delay of 45 seconds is not adjustable. The blower-off delay (time that the blower operates after the heating demand has been satisfied) can be adjusted by moving switches 3 and 4 on the integrated control board. The unit is shipped from the factory with a blower-off delay of 90 seconds. The blower off delay affects comfort and is adjustable to satisfy individual applications. Adjust the blower off delay to achieve a supply air temperature between 90° and 110°F at the exact moment that the blower is de-energized. Longer off delay settings provide lower supply air temperatures; shorter settings provide higher supply air temperatures. Table 12 provides the blower off timings that will result from different switch settings.

**TABLE 12
Blower Off Delay Switch Settings**

Blower Off Delay (Seconds)	Switch 3	Switch 4
60	Off	On
90	Off	Off
120	On	Off
180	On	On

Indoor Blower Operation DIP Switch Settings -- Figure 57

Switches 5 and 6 -- Cooling Mode Blower Speed -- Switches 5 and 6 are used to select cooling blower motor speed. The unit is shipped from the factory with the DIP switches positioned for high speed (4) indoor blower motor operation during the cooling mode. The table below provides the cooling mode blower speeds that will result from different switch settings. Refer to tables 17 through 28 for corresponding cfm values.

**TABLE 13
Cooling Mode Blower Speeds**

Speed	Switch 5	Switch 6
1 - Low	On	On
2 - Medium Low	Off	On
3 - Medium High	On	Off
4 - High (Factory)	Off	Off

Switches 7 and 8 -- Blower Speed Adjustment -- Switches 7 and 8 are used to select blower speed adjustment settings. The unit is shipped from the factory with the DIP switches positioned for NORMAL (no) adjustment. The DIP switches may be positioned to adjust the blower speed by +10% or -10% to better suit the application. The table below provides blower speed adjustments that will result from different switch settings. Refer to tables 17 through 28 for corresponding cfm values.

**TABLE 14
Blower Speed Adjustment**

Adjustment	Switch 7	Switch 8
+10% (approx.)	On	Off
NORMAL (Factory)	Off	Off
-10% (approx.)	Off	On

Switches 9 and 10 -- Cooling Mode Blower Speed Ramping -- Switches 9 and 10 are used to select cooling mode blower speed ramping options. Blower speed ramping may be used to enhance dehumidification performance. The switches are factory set at option A which has the greatest effect on blower motor performance. Table 15 provides the cooling mode blower speed ramping options that will result from different switch settings. The cooling mode blower speed ramping options are detailed on the next page.

NOTE - The off portion of the selected ramp profile only applies during heat pump operation in dual fuel applications.

TABLE 15
Cooling Mode Blower Speed Ramping

Ramping Option	Switch 9	Switch 10
A (Factory)	Off	Off
B	On	Off
C	Off	On
D	On	On

Ramping Option A (Factory Selection)

- Motor runs at 50% for 30 seconds.
- Motor then runs at 82% for approximately 7-1/2 minutes.
- If demand has not been satisfied after 7-1/2 minutes, motor runs at 100% until demand is satisfied.
- Once demand is met, motor runs at 50% for 30 seconds then ramps down to stop.

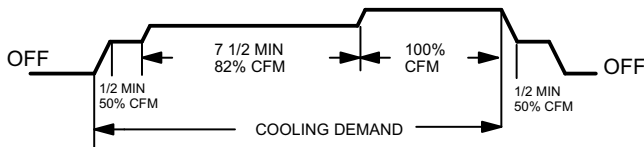

Ramping Option B

- Motor runs at 82% for approximately 7-1/2 minutes. If demand has not been satisfied after 7-1/2 minutes, motor runs at 100% until demand is satisfied.
- Once demand is met, motor ramps down to stop.

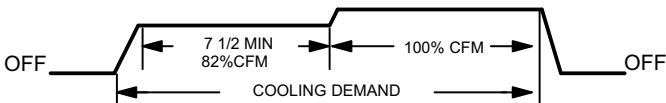

Ramping Option C

- Motor runs at 100% until demand is satisfied.
- Once demand is met, motor runs at 100% for 45 seconds then ramps down to stop.

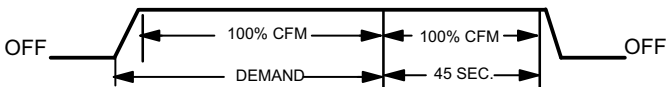

Ramping Option D

- Motor runs at 100% until demand is satisfied.
- Once demand is met, motor ramps down to stop.

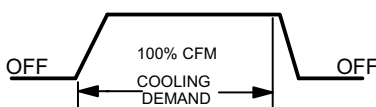

Switches 11 and 12 -- Heating Mode Blower Speed --

Switches 11 and 12 are used to select heating mode blower motor speed. The unit is shipped from the factory with the dip switches positioned for medium low (2) speed indoor blower motor operation during the heating mode. The table below provides the heating mode blower speeds that will result from different switch settings. Refer to tables 17 through 28 for corresponding cfm values.

TABLE 16
Heating Mode Blower Speeds

Speed	Switch 11	Switch 12
1 - Low	On	On
2 - Medium Low (Factory)	Off	On
3 - Medium High	On	Off
4 - High	Off	Off

On-Board Jumper W914 -- Figure 57

On-board jumper W914, which connects terminals DS and R on the integrated control board, must be cut when the furnace is installed with either the Harmony III™ zone control board or a thermostat which features humidity control. If the jumper is left intact the PMW signal from the Harmony III control will be blocked and also lead to control damage. Refer to table 29 for operation sequence in applications including G61MPV, a thermostat which features humidity control and a single-speed outdoor unit. Table 30 gives the operation sequence in applications with a two-speed outdoor unit.

On-Board Jumper W951 -- Figure 57

On-board jumper W951, which connects terminals R and O on the integrated control board, must be cut when the furnace is installed in applications which include a heat pump unit and a thermostat which features dual fuel use. If the jumper is left intact, terminal "O" will remain energized eliminating the HEAT MODE in the heat pump.

On-Board Jumper W915 -- Figure 57

On-board jumper W915, which connects terminals Y1 and Y2 on the integrated control board, must be cut if two-stage cooling will be used. If the jumper is not cut the outdoor unit will operate in second-stage cooling only.

LEDs (SPEED, CFM, STATUS, E-COM) -- Figure 56

The green SPEED LED indicates circulating blower speed in response to the DS signal. The LED is lit during normal blower operation and is off during a dehumidification demand. In Harmony III applications, the brightness of the LED indicates the requested blower speed.

The green CFM LED indicates the blower air flow. Count the number of blinks between the two-second pauses to determine the CFM. Each blink represents approximately 100 CFM.

The STATUS LED flashes diagnostic codes, which are detailed on page 43.

The green E-COM LED indicates that the control is receiving and processing commands and inputs. The LED may flash rapidly or may display a single flash, depending upon the activity.

TABLE 17
G61MPV-36B-045 BLOWER MOTOR PERFORMANCE (LESS FILTER)
0.0" to 0.8" w.g. (0 through 200 Pa) External Static Pressure Range
Factory Settings: Heating Speed - 2; Cooling Speed - 4; Speed Adjust - NORM

"ADJUST" Switch Positions	Speed Switch Positions															
	Second Stage "HEAT" Speed								Second Stage "COOL" Speed							
	1		2		3		4		1		2		3		4	
	cfm	L/s	cfm	L/s	cfm	L/s	cfm	L/s	cfm	L/s	cfm	L/s	cfm	L/s	cfm	L/s
+	915	430	1070	505	1320	625	1370	645	1055	500	1235	580	1330	625	1420	670
NORM	830	395	965	455	1205	570	1255	590	945	445	100	520	1185	560	1295	610
—	740	350	860	405	1055	500	1095	515	840	395	970	460	1050	495	1150	540

"ADJUST" Switch Positions	First Stage "HEAT" Speed								First Stage "COOL" Speed							
	1		2		3		4		1		2		3		4	
	cfm	L/s	cfm	L/s	cfm	L/s	cfm	L/s	cfm	L/s	cfm	L/s	cfm	L/s	cfm	L/s
+	830	390	970	460	1210	570	1255	590	720	340	820	385	890	420	970	455
NORM	755	355	880	415	1080	510	1120	530	665	310	745	350	795	375	875	410
—	690	325	795	375	950	450	995	470	610	290	685	325	725	340	785	370

N/A - First and second stage HEAT positions shown cannot be used on this model.

NOTES - The effect of static pressure is included in air volumes shown.

First stage HEAT is approximately **91%** of the same second stage HEAT speed position.

First stage COOL (two-stage air conditioning units only) is approximately **70%** of the same second stage COOL speed position.

Continuous Fan Only speed is approximately **38%** of the same second stage COOL speed position - minimum 500 cfm (235 L/s).

Lennox Harmony III™ Zone Control Applications - Minimum blower speed is 442 cfm (210 L/s).

TABLE 18
G61MPV-36B-070 and G61MPV-36B-071 BLOWER MOTOR PERFORMANCE (LESS FILTER)
0.0" to 0.8" w.g. (0 through 200 Pa) External Static Pressure Range
Factory Settings: Heating Speed - 2; Cooling Speed - 4; Speed Adjust - NORM

"ADJUST" Switch Positions	Speed Switch Positions															
	Second Stage "HEAT" Speed								Second Stage "COOL" Speed							
	1		2		3		4		1		2		3		4	
	cfm	L/s	cfm	L/s	cfm	L/s	cfm	L/s	cfm	L/s	cfm	L/s	cfm	L/s	cfm	L/s
+	895	420	1025	485	1290	610	1340	630	1015	480	1190	560	1280	605	1395	660
NORM	820	385	940	445	1155	545	1210	570	930	440	1065	505	1155	545	1270	600
—	N/A	N/A	840	395	1020	480	1055	495	830	390	950	450	1010	475	1105	520

"ADJUST" Switch Positions	First Stage "HEAT" Speed								First Stage "COOL" Speed							
	1		2		3		4		1		2		3		4	
	cfm	L/s	cfm	L/s	cfm	L/s	cfm	L/s	cfm	L/s	cfm	L/s	cfm	L/s	cfm	L/s
+	820	385	930	440	1160	550	1210	570	730	345	815	385	865	410	935	440
NORM	760	360	865	410	1045	495	1090	515	680	320	755	355	795	375	855	405
—	N/A	N/A	775	365	930	440	965	455	625	295	695	330	730	345	775	365

N/A - First and second stage HEAT positions shown cannot be used on this model.

NOTES - The effect of static pressure is included in air volumes shown.

First stage HEAT is approximately **91%** of the same second stage HEAT speed position.

First stage COOL (two-stage air conditioning units only) is approximately **70%** of the same second stage COOL speed position.

Continuous Fan Only speed is approximately **38%** of the same second stage COOL speed position - minimum 500 cfm (235 L/s).

Lennox Harmony III™ Zone Control Applications - Minimum blower speed is 458 cfm (215 L/s).

TABLE 19
G61MPV-36C-090 BLOWER MOTOR PERFORMANCE (LESS FILTER)
0.0" to 0.8" w.g. (0 through 200 Pa) External Static Pressure Range
Factory Settings: Heating Speed - 2; Cooling Speed - 4; Speed Adjust - NORM

"ADJUST" Switch Positions	Speed Switch Positions															
	Second Stage "HEAT" Speed								Second Stage "COOL" Speed							
	1		2		3		4		1		2		3		4	
	cfm	L/s	cfm	L/s	cfm	L/s	cfm	L/s	cfm	L/s	cfm	L/s	cfm	L/s	cfm	L/s
+	N/A	N/A	1040	490	1285	605	1340	630	1020	480	1185	560	1275	600	1395	660
NORM	N/A	N/A	915	430	1150	540	1200	565	905	430	1060	500	1145	540	1270	600
—	N/A	N/A	N/A	N/A	1020	480	1055	495	800	380	925	435	1010	475	1100	520

"ADJUST" Switch Positions	First Stage "HEAT" Speed								First Stage "COOL" Speed							
	1		2		3		4		1		2		3		4	
	cfm	L/s	cfm	L/s	cfm	L/s	cfm	L/s	cfm	L/s	cfm	L/s	cfm	L/s	cfm	L/s
+	N/A	N/A	940	445	1160	550	1210	570	705	335	790	375	845	400	920	435
NORM	N/A	N/A	840	395	1040	490	1075	510	650	305	730	345	770	365	830	395
—	N/A	N/A	N/A	N/A	915	430	945	445	600	285	670	315	705	330	750	355

N/A - First and second stage HEAT positions shown cannot be used on this model.

NOTES - The effect of static pressure is included in air volumes shown.

First stage HEAT is approximately **91%** of the same second stage HEAT speed position.

First stage COOL (two-stage air conditioning units only) is approximately **70%** of the same second stage COOL speed position.

Continuous Fan Only speed is approximately **38%** of the same second stage COOL speed position - minimum 500 cfm (235 L/s).

Lennox Harmony III™ Zone Control Applications - Minimum blower speed is 479 cfm (225 L/s).

TABLE 20
G61MPV-60C-090 and G61MPV-60C-091 BLOWER MOTOR PERFORMANCE (LESS FILTER)
0.0" to 0.8" w.g. (0 through 200 Pa) External Static Pressure Range
Factory Settings: Heating Speed - 2; Cooling Speed - 4; Speed Adjust - NORM.
Return Air Options: Bottom; both sides; or bottom and one side.

"ADJUST" Switch Positions	Speed Switch Positions															
	Second Stage "HEAT" Speed								Second Stage "COOL" Speed							
	1		2		3		4		1		2		3		4	
	cfm	L/s	cfm	L/s	cfm	L/s	cfm	L/s	cfm	L/s	cfm	L/s	cfm	L/s	cfm	L/s
+	1500	710	1675	790	1880	885	2090	985	1605	760	1710	805	1925	910	2165	1020
NORM	1355	640	1545	730	1720	810	1900	895	1440	680	1560	735	1755	825	1960	925
—	1194	565	1365	645	1540	730	1695	800	1275	600	1380	650	1590	750	1755	830

"ADJUST" Switch Positions	First Stage "HEAT" Speed								First Stage "COOL" Speed							
	1		2		3		4		1		2		3		4	
	cfm	L/s	cfm	L/s	cfm	L/s	cfm	L/s	cfm	L/s	cfm	L/s	cfm	L/s	cfm	L/s
+	1360	640	1560	735	1730	815	1910	900	1105	520	1185	560	1355	640	1545	730
NORM	1220	575	1405	665	1585	750	1740	820	995	470	1080	510	1205	570	1345	635
—	1105	520	1235	585	1410	665	1570	740	890	420	960	455	1090	515	1215	575

NOTES - The effect of static pressure is included in air volumes shown.

First stage HEAT is approximately **91%** of the same second stage HEAT speed position.

First stage COOL (two-stage air conditioning units only) is approximately **70%** of the same second stage COOL speed position.

Continuous Fan Only speed is approximately **38%** of the same second stage COOL speed position - minimum 500 cfm (235 L/s).

Lennox Harmony III™ Zone Control Applications - Minimum blower speed is 449 cfm (210 L/s).

TABLE 21
G61MPV-60C-090 and G61MPV-60C-091 BLOWER MOTOR PERFORMANCE (LESS FILTER)
0.0" to 0.8" w.g. (0 through 200 Pa) External Static Pressure Range
Factory Settings: Heating Speed - 2; Cooling Speed - 4; Speed Adjust - NORM.

Return Air Options: Single side return air - Bold volumes require field-fabricated transition to accommodate 20 x 25 x 1 in. (508 x 635 x 25 mm) cleanable air filter in order to maintain proper air velocity across the filter.

"ADJUST" Switch Positions	Speed Switch Positions															
	Second Stage "HEAT" Speed								Second Stage "COOL" Speed							
	1		2		3		4		1		2		3		4	
	cfm	L/s	cfm	L/s	cfm	L/s	cfm	L/s	cfm	L/s	cfm	L/s	cfm	L/s	cfm	L/s
+	1450	685	1640	775	1820	860	2055	970	1575	745	1690	795	1895	895	2135	1005
NORM	1320	625	1510	710	1700	800	1870	880	1405	665	1530	720	1735	820	1935	910
—	1165	550	1320	625	1500	705	1665	785	1250	590	1355	640	1560	735	1735	820

"ADJUST" Switch Positions	First Stage "HEAT" Speed								First Stage "COOL" Speed							
	1		2		3		4		1		2		3		4	
	cfm	L/s	cfm	L/s	cfm	L/s	cfm	L/s	cfm	L/s	cfm	L/s	cfm	L/s	cfm	L/s
+	1315	620	1510	715	1695	800	1875	885	1080	510	1160	545	1315	620	1490	705
NORM	1190	560	1365	645	1545	730	1715	810	985	465	1060	500	1185	560	1330	625
—	1075	510	1205	570	1370	645	1520	715	865	410	930	440	1065	500	1185	560

NOTES - The effect of static pressure is included in air volumes shown.
 First stage HEAT is approximately **91%** of the same second stage HEAT speed position.
 First stage COOL (two-stage air conditioning units only) is approximately **70%** of the same second stage COOL speed position.
 Continuous Fan Only speed is approximately **38%** of the same second stage COOL speed position - minimum 500 cfm (235 L/s).
 Lennox Harmony III™ Zone Control Applications - Minimum blower speed is 449 cfm (210 L/s).

TABLE 22
G61MPV-60C-090 and G61MPV-60C-091 BLOWER MOTOR PERFORMANCE (LESS FILTER)
0.0" to 0.8" w.g. (0 through 200 Pa) External Static Pressure Range
Factory Settings: Heating Speed - 2; Cooling Speed - 4; Speed Adjust - NORM.
Return Air Options: Single side return with optional RAB return air base

"ADJUST" Switch Positions	Speed Switch Positions															
	Second Stage "HEAT" Speed								Second Stage "COOL" Speed							
	1		2		3		4		1		2		3		4	
	cfm	L/s	cfm	L/s	cfm	L/s	cfm	L/s	cfm	L/s	cfm	L/s	cfm	L/s	cfm	L/s
+	1440	680	1630	770	1810	855	2015	950	1525	720	1655	780	1860	880	2100	990
NORM	1300	615	1485	700	1655	780	1830	865	1385	655	1500	710	1695	800	1905	900
—	1155	545	1310	620	1480	700	1640	775	1240	585	1320	625	1510	710	1695	800

"ADJUST" Switch Positions	First Stage "HEAT" Speed								First Stage "COOL" Speed							
	1		2		3		4		1		2		3		4	
	cfm	L/s	cfm	L/s	cfm	L/s	cfm	L/s	cfm	L/s	cfm	L/s	cfm	L/s	cfm	L/s
+	1320	625	1490	700	1665	785	1840	870	1060	500	1135	535	1285	605	1455	685
NORM	1180	555	1345	635	1515	715	1680	795	960	455	1035	490	1165	550	1310	620
—	1055	500	1180	560	1340	630	1490	705	865	405	920	435	1050	495	1165	550

NOTES - The effect of static pressure is included in air volumes shown.
 First stage HEAT is approximately **91%** of the same second stage HEAT speed position.
 First stage COOL (two-stage air conditioning units only) is approximately **70%** of the same second stage COOL speed position.
 Continuous Fan Only speed is approximately **38%** of the same second stage COOL speed position - minimum 500 cfm (235 L/s).
 Lennox Harmony III™ Zone Control Applications - Minimum blower speed is 449 cfm (210 L/s).

TABLE 23
G61MPV-60C-110 and G61MPV-60C-111 BLOWER MOTOR PERFORMANCE (LESS FILTER)
0.0" to 0.8" w.g. (0 through 200 Pa) External Static Pressure Range
Factory Settings: Heating Speed - 2; Cooling Speed - 4; Speed Adjust - NORM.
Return Air Options: Bottom; both sides; or bottom and one side.

"ADJUST" Switch Positions	Speed Switch Positions															
	Second Stage "HEAT" Speed								Second Stage "COOL" Speed							
	1		2		3		4		1		2		3		4	
	cfm	L/s	cfm	L/s	cfm	L/s	cfm	L/s	cfm	L/s	cfm	L/s	cfm	L/s	cfm	L/s
+	1505	710	1710	805	1915	905	2130	1005	1625	770	1745	825	1990	940	2210	1045
NORM	1370	645	1565	740	1765	835	1945	920	1465	690	1580	745	1790	845	1995	940
—	1205	570	1380	650	1565	740	1740	820	1290	610	1405	660	1605	760	1790	845
"ADJUST" Switch Positions	First Stage "HEAT" Speed								First Stage "COOL" Speed							
	1		2		3		4		1		2		3		4	
	cfm	L/s	cfm	L/s	cfm	L/s	cfm	L/s	cfm	L/s	cfm	L/s	cfm	L/s	cfm	L/s
+	1370	645	1570	740	1760	830	1945	920	945	445	1020	480	1160	545	1300	615
NORM	1235	585	1420	670	1600	755	1780	840	840	395	910	430	1055	500	1180	555
—	1105	525	1250	590	1420	670	1580	745	740	350	800	380	920	435	1045	495

NOTES - The effect of static pressure is included in air volumes shown.
 First stage HEAT is approximately **91%** of the same second stage HEAT speed position.
 First stage COOL (two-stage air conditioning units only) is approximately 70% of the same second stage COOL speed position.
 Continuous Fan Only speed is approximately **38%** of the same second stage COOL speed position - minimum 500 cfm (235 L/s).
 Lennox Harmony III™ Zone Control Applications - Minimum blower speed is 463 cfm (220 L/s).

TABLE 24
G61MPV-60C-110 and G61MPV-60C-111 BLOWER MOTOR PERFORMANCE (LESS FILTER)
0.0" to 0.8" w.g. (0 through 200 Pa) External Static Pressure Range
Factory Settings: Heating Speed - 2; Cooling Speed - 4; Speed Adjust - NORM.
Return Air Options: Single side return air - Bold volumes require field-fabricated transition to accommodate
20 x 25 x 1 in. (508 x 635 x 25 mm) cleanable air filter in order to maintain proper air velocity across the filter.

"ADJUST" Switch Positions	Speed Switch Positions															
	Second Stage "HEAT" Speed								Second Stage "COOL" Speed							
	1		2		3		4		1		2		3		4	
	cfm	L/s	cfm	L/s	cfm	L/s	cfm	L/s	cfm	L/s	cfm	L/s	cfm	L/s	cfm	L/s
+	1485	700	1675	790	1870	885	2080	980	1585	750	1700	800	1905	900	2135	1005
NORM	1350	637	1525	720	1725	815	1895	895	1435	680	1535	725	1740	820	1930	910
—	1175	555	1335	630	1505	710	1670	790	1280	605	1385	655	1570	740	1755	830
"ADJUST" Switch Positions	First Stage "HEAT" Speed								First Stage "COOL" Speed							
	1		2		3		4		1		2		3		4	
	cfm	L/s	cfm	L/s	cfm	L/s	cfm	L/s	cfm	L/s	cfm	L/s	cfm	L/s	cfm	L/s
+	1325	625	1505	710	1695	800	1870	885	935	440	1025	485	1155	545	1285	605
NORM	1195	565	1365	645	1550	730	1720	810	840	395	915	430	1050	495	1175	555
—	1080	510	1205	570	1365	645	1530	720	750	355	800	380	925	435	1050	495

NOTES - The effect of static pressure is included in air volumes shown.
 First stage HEAT is approximately **91%** of the same second stage HEAT speed position.
 First stage COOL (two-stage air conditioning units only) is approximately 70% of the same second stage COOL speed position.
 Continuous Fan Only speed is approximately **38%** of the same second stage COOL speed position - minimum 500 cfm (235 L/s).
 Lennox Harmony III™ Zone Control Applications - Minimum blower speed is 463 cfm (220 L/s).

TABLE 25
G61MPV-60C-110 and G61MPV-60C-111 BLOWER MOTOR PERFORMANCE (LESS FILTER)
0.0" to 0.8" w.g. (0 through 200 Pa) External Static Pressure Range
Factory Settings: Heating Speed - 2; Cooling Speed - 4; Speed Adjust - NORM.
Return Air Options: Single side return air with optional RAB return base. -
20 x 25 x 1 in. (508 x 635 x 25 mm) cleanable air filter in order to maintain proper air velocity across the filter.

"ADJUST" Switch Positions	Speed Switch Positions															
	Second Stage "HEAT" Speed								Second Stage "COOL" Speed							
	1		2		3		4		1		2		3		4	
	cfm	L/s	cfm	L/s	cfm	L/s	cfm	L/s	cfm	L/s	cfm	L/s	cfm	L/s	cfm	L/s
+	1475	695	1670	790	1865	880	2070	980	1555	735	1685	795	1895	895	2130	1005
NORM	1345	635	1500	710	1695	800	1865	880	1415	670	1540	725	1735	820	1930	910
—	1180	555	1345	635	1510	710	1685	795	1245	590	1350	635	1545	730	1725	815

"ADJUST" Switch Positions	First Stage "HEAT" Speed								First Stage "COOL" Speed							
	1		2		3		4		1		2		3		4	
	cfm	L/s	cfm	L/s	cfm	L/s	cfm	L/s	cfm	L/s	cfm	L/s	cfm	L/s	cfm	L/s
+	1330	625	1510	715	1695	800	1875	885	1085	510	1155	545	1310	620	1475	695
NORM	1195	565	1375	650	1550	730	1725	815	955	450	1050	495	1185	560	1335	630
—	1080	510	1210	570	1370	645	1520	715	850	400	920	435	1070	505	1195	565

NOTES - The effect of static pressure is included in air volumes shown.
 First stage HEAT is approximately **91%** of the same second stage HEAT speed position.
 First stage COOL (two-stage air conditioning units only) is approximately **70%** of the same second stage COOL speed position.
 Continuous Fan Only speed is approximately **38%** of the same second stage COOL speed position - minimum 500 cfm (235 L/s).
 Lennox Harmony III™ Zone Control Applications - Minimum blower speed is 463 cfm (220 L/s).

TABLE 26
G61MPV-60D-135 BLOWER MOTOR PERFORMANCE (LESS FILTER)
0.0" to 0.8" w.g. (0 through 200 Pa) External Static Pressure Range
Factory Settings: Heating Speed - 2; Cooling Speed - 4; Speed Adjust - NORM.
Return Air Options: Bottom; both sides; or bottom and one side.

"ADJUST" Switch Positions	Speed Switch Positions															
	Second Stage "HEAT" Speed								Second Stage "COOL" Speed							
	1		2		3		4		1		2		3		4	
	cfm	L/s	cfm	L/s	cfm	L/s	cfm	L/s	cfm	L/s	cfm	L/s	cfm	L/s	cfm	L/s
+	1505	710	1705	805	1900	900	2110	995	1615	760	1730	815	1945	920	2190	1035
NORM	1365	645	1550	730	1740	820	1920	905	1455	685	1580	745	1780	840	1985	935
—	1225	580	1380	650	1545	730	1720	810	1305	615	1400	660	1600	755	1780	840

"ADJUST" Switch Positions	First Stage "HEAT" Speed								First Stage "COOL" Speed							
	1		2		3		4		1		2		3		4	
	cfm	L/s	cfm	L/s	cfm	L/s	cfm	L/s	cfm	L/s	cfm	L/s	cfm	L/s	cfm	L/s
+	1385	655	1570	740	1760	830	1930	910	1135	535	1205	570	1365	645	1540	725
NORM	1250	590	1425	670	1595	755	1775	835	1025	485	1105	520	1235	580	1390	655
—	1135	535	1265	595	1430	675	1585	750	915	430	985	465	1115	525	1235	585

NOTES - The effect of static pressure is included in air volumes shown.
 First stage HEAT is approximately **91%** of the same second stage HEAT speed position.
 First stage COOL (two-stage air conditioning units only) is approximately **70%** of the same second stage COOL speed position.
 Continuous Fan Only speed is approximately **38%** of the same second stage COOL speed position - minimum 500 cfm (235 L/s).
 Lennox Harmony III™ Zone Control Applications - Minimum blower speed is 470 cfm (210 L/s).

TABLE 27
G61MPV-60D-135 BLOWER MOTOR PERFORMANCE (LESS FILTER)
0.0" to 0.8" w.g. (0 through 200 Pa) External Static Pressure Range

Factory Settings: Heating Speed - 2; Cooling Speed - 4; Speed Adjust - NORM.

Return Air Options: Single side return air - Bold volumes require field-fabricated transition to accommodate 20 x 25 x 1 in. (508 x 635 x 25 mm) cleanable air filter in order to maintain proper air velocity across the filter.

"ADJUST" Switch Positions	Speed Switch Positions															
	Second Stage "HEAT" Speed								Second Stage "COOL" Speed							
	1		2		3		4		1		2		3		4	
	cfm	L/s	cfm	L/s	cfm	L/s	cfm	L/s	cfm	L/s	cfm	L/s	cfm	L/s	cfm	L/s
+	1470	695	1650	780	1845	870	2040	965	1585	750	1705	805	1905	900	2130	1005
NORM	1325	625	1495	705	1680	795	1865	880	1430	675	1545	730	1765	835	1975	930
—	N/A	N/A	1335	630	1505	710	1670	790	1275	600	1370	645	1565	740	1755	830

"ADJUST" Switch Positions	First Stage "HEAT" Speed								First Stage "COOL" Speed							
	1		2		3		4		1		2		3		4	
	cfm	L/s	cfm	L/s	cfm	L/s	cfm	L/s	cfm	L/s	cfm	L/s	cfm	L/s	cfm	L/s
+	1335	630	1510	710	1695	800	1870	885	1105	520	1180	555	1330	630	1500	710
NORM	1210	570	1370	645	1540	725	1710	810	990	465	1075	505	1210	570	1355	640
—	N/A	N/A	1225	575	1375	650	1515	715	890	420	950	450	1085	515	1210	570

N/A - First and second stage HEAT positions shown cannot be used on this model.

NOTES - The effect of static pressure is included in air volumes shown.

First stage HEAT is approximately **91%** of the same second stage HEAT speed position.

First stage COOL (two-stage air conditioning units only) is approximately **70%** of the same second stage COOL speed position.

Continuous Fan Only speed is approximately **38%** of the same second stage COOL speed position - minimum 500 cfm (235 L/s).

Lennox Harmony III™ Zone Control Applications - Minimum blower speed is 470 cfm (220 L/s).

TABLE 28
G61MPV-60D-135 BLOWER MOTOR PERFORMANCE (LESS FILTER)
0.0" to 0.8" w.g. (0 through 200 Pa) External Static Pressure Range

Factory Settings: Heating Speed - 2; Cooling Speed - 4; Speed Adjust - NORM.

Return Air Options: Single side return air with optional RAB return air base 20 x 25 x 1 in. (508 x 635 x 25 mm) cleanable air filter in order to maintain proper air velocity across the filter.

"ADJUST" Switch Positions	Speed Switch Positions															
	Second Stage "HEAT" Speed								Second Stage "COOL" Speed							
	1		2		3		4		1		2		3		4	
	cfm	L/s	cfm	L/s	cfm	L/s	cfm	L/s	cfm	L/s	cfm	L/s	cfm	L/s	cfm	L/s
+	1445	685	1635	770	1825	860	2025	955	1550	730	1660	785	1875	885	2105	995
NORM	1305	615	1475	695	1660	785	1840	870	1400	660	1510	715	1720	810	1920	905
—	N/A	N/A	1315	620	1480	700	1650	780	1250	590	1345	635	1530	725	1715	810

"ADJUST" Switch Positions	First Stage "HEAT" Speed								First Stage "COOL" Speed							
	1		2		3		4		1		2		3		4	
	cfm	L/s	cfm	L/s	cfm	L/s	cfm	L/s	cfm	L/s	cfm	L/s	cfm	L/s	cfm	L/s
+	1315	620	1490	705	1675	790	1855	875	1080	510	1155	545	1310	620	1478	695
NORM	1195	565	1365	645	1530	725	1695	800	985	465	1055	500	1190	560	1325	625
—	N/A	N/A	1210	570	1360	640	1500	710	875	410	945	445	1060	500	1190	560

N/A - First and second stage HEAT positions shown cannot be used on this model.

NOTES - The effect of static pressure is included in air volumes shown.

First stage HEAT is approximately **91%** of the same second stage HEAT speed position.

First stage COOL (two-stage air conditioning units only) is approximately **70%** of the same second stage COOL speed position.

Continuous Fan Only speed is approximately **38%** of the same second stage COOL speed position - minimum 500 cfm (235 L/s).

Lennox Harmony III™ Zone Control Applications - Minimum blower speed is 470 cfm (220 L/s).

**TABLE 29
OPERATING SEQUENCE
G61MPV, SignatureStat™ Thermostat and Single-Stage Outdoor Unit**

OPERATING SEQUENCE		SYSTEM DEMAND							SYSTEM RESPONSE			
System Condition	Step	Thermostat Demand					Relative Humidity		Compressor	Blower CFM (COOL)	Comments	
		Y1		O	G	W 1	Status	D				
<i>NO CALL FOR DEHUMIDIFICATION</i>												
Normal Operation	1	On		On	On		Acceptable	24 VAC	High	100%	Compressor and indoor blower follow thermostat demand	
<i>BASIC MODE (only active on a Y1 thermostat demand)</i>												
Normal Operation	1	On		On	On		Acceptable	24 VAC	High	100%	SignatureStat™ thermostat energizes Y1 and de-energizes D on a call for de-humidification	
Dehumidification Call	2	On		On	On		Demand	0 VAC	High	70%		
<i>PRECISION MODE (operates independent of a Y1 thermostat demand)</i>												
Normal Operation	1	On		On	On		Acceptable	24 VAC	High	100%	Dehumidification mode begins when humidity is greater than set point	
Dehumidification call	2	On		On	On		Demand	0 VAC	High	70%		
Dehumidification call ONLY	1	On		On	On		Demand	0 VAC	High	70%	SignatureStat™ thermostat will keep outdoor unit energized after cooling temperature setpoint has been reached in order to maintain room humidity setpoint.*	
Jumpers at indoor unit with a single stage outdoor unit With Condensing unit - Cut W914 (R to DS) on SureLight® board With Heat Pump - Cut W914 (R to DS) & W951 (R to O) on SureLight® board												

**In Precision mode, SignatureStat™ thermostat will allow room temperatures up to 2 °F (1.2°C) cooler than room setting.*

**TABLE 30
OPERATING SEQUENCE
G61MPV, SignatureStat™ Thermostat and Two-Stage Outdoor Unit**

OPERATING SEQUENCE		SYSTEM DEMAND								SYSTEM RESPONSE		
System Condition	Step	Thermostat Demand						Relative Humidity		Compressor	Blower CFM (COOL)	Comments
		Y1	Y2	O	G	W 1	W 2	Status	D			
NO CALL FOR DEHUMIDIFICATION												
Normal Operation - Y1	1	On		On	On			Acceptable	24 VAC	Low	70%	Compressor and indoor blower follow thermostat demand
Normal Operation - Y2	2	On	On	On	On			Acceptable	24 VAC	High	100%	
ROOM THERMOSTAT CALLS FOR FIRST STAGE COOLING												
<i>BASIC MODE (only active on a Y1 thermostat demand)</i>												
Normal Operation	1	On		On	On			Acceptable	24 VAC	Low	70%	SignatureStat™ thermostat energizes Y2 and de-energizes D on a call for dehumidification
Dehumidification Call	2	On	On	On	On			Demand	0 VAC	High	70%	
<i>PRECISION MODE (operates independent of a Y1 thermostat demand)</i>												
Normal Operation	1	On		On	On			Acceptable	24 VAC	Low	70%	Dehumidification mode begins when humidity is greater than set point
Dehumidification call	2	On	On	On	On			Demand	0 VAC	High	70%	
Dehumidification call ONLY	1	On	On	On	On			Demand	0 VAC	High	70%	SignatureStat™ thermostat will keep outdoor unit energized after cooling temperature setpoint has been reached in order to maintain room humidity setpoint.*
ROOM THERMOSTAT CALLS FOR FIRST AND SECOND STAGE COOLING												
<i>BASIC MODE (only active on a Y1 thermostat demand)</i>												
Normal Operation	1	On	On	On	On			Acceptable	24 VAC	High	100%	SignatureStat™ thermostat energizes Y2 and de-energizes D on a call for dehumidification
Dehumidification Call	2	On	On	On	On			Demand	0 VAC	High	70%	
<i>PRECISION MODE (operates independent of a Y1 thermostat demand)</i>												
Normal Operation	1	On		On	On			Acceptable	24 VAC	Low	70%	Dehumidification mode begins when humidity is greater than set point
Dehumidification call	2	On	On	On	On			Demand	0 VAC	High	70%	
Dehumidification call ONLY	1	On	On	On	On			Demand	0 VAC	High	70%	SignatureStat™ thermostat will keep outdoor unit energized after cooling temperature setpoint has been reached in order to maintain room humidity setpoint.*
Jumpers at indoor unit with a two stage outdoor unit Cut factory jumper from Y1 to Y2 or cut W915 (Y1 to Y2) on SureLight® board With Condensing unit - Cut W914 (R to DS) on SureLight® board With Heat Pump - Cut W914 (R to DS) & W951 (R to O) on SureLight® board											SignatureStat™ thermostat will keep outdoor unit energized after cooling temperature setpoint has been reached in order to maintain room humidity setpoint.*	

*In Precision mode, SignatureStat™ thermostat will allow room temperature up to 2 °F (1.2°C) cooler than room setting.

Unit Start-Up

FOR YOUR SAFETY READ BEFORE OPERATING

⚠ WARNING

Do not use this furnace if any part has been underwater. A flood-damaged furnace is extremely dangerous. Attempts to use the furnace can result in fire or explosion. Immediately call a qualified service technician to inspect the furnace and to replace all gas controls, control system parts, and electrical parts that have been wet or to replace the furnace, if deemed necessary.

⚠ WARNING



Danger of explosion. Can cause injury or product or property damage. Should the gas supply fail to shut off or if overheating occurs, shut off the gas valve to the furnace before shutting off the electrical supply.

⚠ CAUTION

Before attempting to perform any service or maintenance, turn the electrical power to unit OFF at disconnect switch.

Priming Condensate Trap

The condensate trap should be primed with water prior to start-up to ensure proper condensate drainage. Either pour 10 fl. oz. (300 ml) of water into the trap, or follow these steps to prime the trap:

- 1 - Follow the lighting instructions to place the unit into operation.
- 2 - Set the thermostat to initiate a heating demand.
- 3 - Allow the burners to fire for approximately 3 minutes.
- 4 - Adjust the thermostat to deactivate the heating demand.
- 5 - Wait for the combustion air inducer to stop. Set the thermostat to initiate a heating demand and again allow the burners to fire for approximately 3 minutes.
- 6 - Adjust the thermostat to deactivate the heating demand and again wait for the combustion air inducer to stop. At this point, the trap should be primed with sufficient water to ensure proper condensate drain operation.

BEFORE LIGHTING the unit, smell all around the furnace area for gas. Be sure to smell next to the floor because some gas is heavier than air and will settle on the floor.

The gas valve on the G61MPV is equipped with a gas control switch (lever). Use only your hand to turn the gas control switch. Never use tools. If the the switch will not move by hand, do not try to repair it. Force or attempted repair may result in a fire or explosion.

Placing the furnace into operation:

G61MPV units are equipped with an automatic ignition system. Do not attempt to manually light burners on this furnace. Each time the thermostat calls for heat, the burners will automatically light. The ignitor does not get hot when there is no call for heat on units with this ignition system.

⚠ WARNING

If you do not follow these instructions exactly, a fire or explosion may result causing property damage, personal injury or death.

Gas Valve Operation (Figures 59 and 60)

- 1 - **STOP!** Read the safety information at the beginning of this section.
- 2 - Set the thermostat to the lowest setting.
- 3 - Turn off all electrical power to the unit.
- 4 - This furnace is equipped with an ignition device which automatically lights the burners. Do **not** try to light the burners by hand.
- 5 - Remove the upper access panel.
- 6 - *White Rodgers 36E Gas Valve* - Move gas valve switch to **OFF**. See figure 59 for the White Rodgers 36E valve.
Honeywell VR8205 Gas Valve - Turn switch on gas valve clockwise  to **OFF**. Do not force. See figure 60.
- 7 - Wait five minutes to clear out any gas. If you then smell gas, **STOP!** Immediately call your gas supplier from a neighbor's phone. Follow the gas supplier's instructions. If you do not smell gas go to next step.

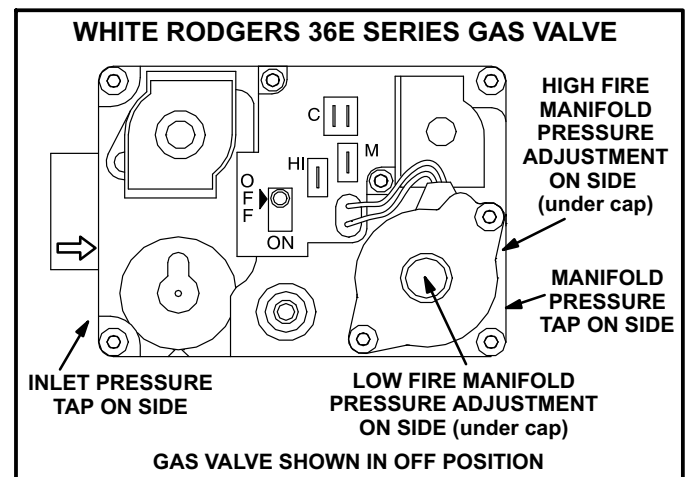

FIGURE 59

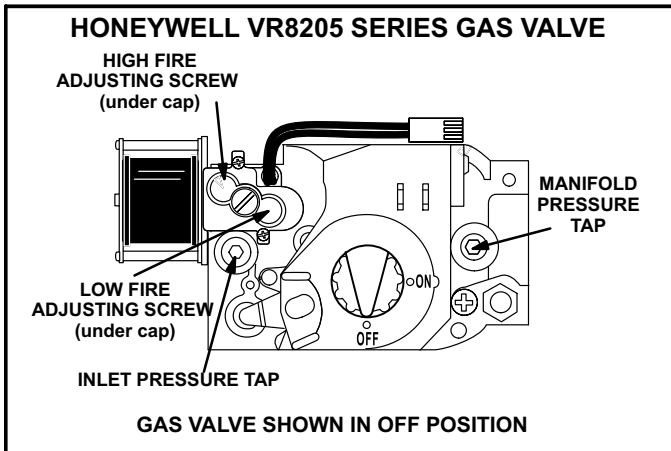



FIGURE 60

8 - *White Rodgers 36E Gas Valve* - Move gas valve switch to **ON**. See figure 59 for the White Rodgers 36E valve.

Honeywell VR8205 Gas Valve - Turn switch on gas valve counterclockwise  to **ON**. Do not force.

9 - Replace the upper access panel.

10- Turn on all electrical power to the unit.

11- Set the thermostat to desired setting.

NOTE - When unit is initially started, steps 1 through 11 may need to be repeated to purge air from gas line.

12- If the appliance will not operate, follow the instructions "Turning Off Gas to Unit" and call the gas supplier.

Turning Off Gas to Unit

1 - Set the thermostat to the lowest setting.

2 - Turn off all electrical power to the unit if service is to be performed.

3 - Remove the upper access panel.

4 - *White Rodgers 36E Gas Valve* - Move switch on gas valve to **OFF**.

Honeywell VR8205 Gas Valve - Turn switch on gas valve clockwise  to **OFF**. Do not force.

5 - Replace the upper access panel.

Gas Pressure Adjustment

Gas Flow (Approximate)

1 - Operate unit at least 15 minutes before checking gas flow. Determine the time in seconds for one revolutions of gas through the meter. A portable LP gas meter (17Y44) is available for LP applications.

2 - Compare the number of seconds and the gas meter size in table 31 to determine the gas flow rate. Multiply the gas flow rate by the heating value to determine the unit input rate. If manifold pressure is correct and the unit input rate is incorrect, check gas orifices for proper size and restriction.

3 - Remove temporary gas meter if installed.

NOTE - To obtain accurate reading, shut off all other gas appliances connected to meter.

TABLE 31

Seconds for 1 Revolution	Gas Flow Rate (Ft. ³ /Hr.)	
	Gas Meter Size	
	1/2 cu ft Dial	1 cu ft Dial
10	180	360
12	150	300
14	129	257
16	113	225
18	100	200
20	90	180
22	82	164
24	75	150
26	69	138
28	64	129
30	60	120
32	56	113
34	53	106
36	50	100
38	47	95
40	45	90
42	43	86
44	41	82
46	39	78
48	38	75
50	36	72
52	35	69
54	33	67
56	32	64
58	31	62
60	30	60

Manifold Pressure Measurement & Adjustment

Supply Pressure Measurement

A threaded plug on the inlet side of the gas valve provides access to the supply pressure tap. Remove the threaded plug, install a field-provided barbed fitting and connect a manometer to measure supply pressure. Replace the threaded plug after measurements have been taken.

Manifold Pressure Measurement

To correctly measure manifold pressure, the differential pressure between the positive gas manifold and the negative burner box must be considered. Use *pressure test adapter kit (available as Lennox part 10L34)* to assist in measurement.

- 1 - Remove the threaded plug from the outlet side of the gas valve and install a field-provided barbed fitting. Connect test gauge “+” connection to barbed fitting to measure manifold pressure.

- 2 - Tee into the gas valve regulator vent hose and connect test gauge “-” connection.
- 3 - Start unit on low heat (68% rate) and allow 5 minutes for unit to reach steady state.
- 4 - While waiting for the unit to stabilize, notice the flame. Flame should be stable and should not lift from burner. Natural gas should burn blue.
- 5 - After allowing unit to stabilize for 5 minutes, record manifold pressure and compare to value given in table 32.
- 6 - Repeat steps 3, 4 and 5 on high heat.

NOTE - Shut unit off and remove manometer as soon as an accurate reading has been obtained. Take care to remove barbed fitting and replace threaded plug.

 CAUTION
Do not attempt to make adjustments to the gas valve.

TABLE 32
Manifold Pressure (Outlet)

Model Number	Fuel	Altitude (feet)											
		0-2000		2001-4500		4501-5500		5501-6500		6501-7500		7501-10000	
		Low Fire	High Fire	Low Fire	High Fiire	Low Fire	High Fiire	Low Fire	High Fiire	Low Fire	High Fiire	Low Fire	High Fiire
045, 070, 071, 090, 110, 135	Natural	1.7	3.5	1.7	3.5	1.7	3.5	1.7	3.5	1.7	3.5	1.7	3.5
	Propane	4.9	10.0	4.9	10.0	4.9	10.0	4.9	10.0	4.9	10.0	4.9	10.0
091, 111	Natural	1.7	3.5	1.7	3.4	1.7	3.3	1.7	3.2	1.7	3.1	1.7	3.5
	Propane	4.9	10.0	4.9	10.0	4.9	10.0	4.9	10.0	4.9	10.0	4.9	10.0

High Altitude Information

NOTE - In Canada, certification for installations at elevations over 4500 feet (1372 m) is the jurisdiction of local authorities.

The manifold pressure may require adjustment to ensure proper operation at higher altitudes. Refer to table 32 for manifold pressure and table 33 for required pressure

switch changes and conversion kits at varying altitudes.

The combustion air pressure switches are factory-set and require no adjustment.

NOTE - A natural to L.P. propane gas changeover kit is necessary to convert this unit. Refer to the changeover kit installation instruction for the conversion procedure.

TABLE 33
Conversion Kit Requirements

Input	High Altitude Orifice Kit Natural Gas Only 7501-10,000 ft.	High Altitude Pressure Switch Kit ORDER TWO EACH			LPG/Propane Kit		LPG/Propane to Natural Gas Kit	
		2000-4500 ft.	4501-7500 ft.	7501-10,000 ft.	0-7500 ft.	7501-10,000 ft.	0-7500 ft.	¹ 7501-10,000 ft.
-045	44W51	---	---	---	44W48	44W50	44W49	44W49 + 44W51
-070	44W51	---	---	56M23	44W48	44W50	44W49	44W49 + 44W51
-071	44W51	75M22	75M22	56M21	44W48	44W50	44W49	44W49 + 44W51
-090	44W51	---	75M22	56M21	44W48	44W50	44W49	44W49 + 44W51
-091	47M82	26W85	26W85	26W86	44W48	44W50	44W49	44W49 + 47M82
-110	44W51	---	56M23	75M22	44W48	44W50	44W49	44W49 + 44W51
-111	47M82	56M22	56M22	56M23	44W48	44W50	44W49	44W49 + 47M82
-135	44W51	---	56M93	56M93	44W48	44W50	44W49	44W49 + 44W51

¹ High Altitude Orifice Kit is required and must be ordered separately for applications from 7501 to 10,000 ft.

Testing for Proper Venting and Sufficient Combustion Air for Non-Direct Vent Applications

WARNING

CARBON MONOXIDE POISONING HAZARD!

Failure to follow the steps outlined below for each appliance connected to the venting system being placed into operation could result in carbon monoxide poisoning or death.

The following steps shall be followed for each appliance connected to the venting system being placed into operation, while all other appliances connected to the venting system are not in operation.

After the G61MPV gas furnace has been started, the following test should be conducted to ensure proper venting and sufficient combustion air has been provided to the G61MPV, as well as to other gas-fired appliances which are separately vented.

If a G61MPV furnace replaces a Category I furnace which was commonly vented with another gas appliance, the size of the existing vent pipe for that gas appliance must be checked. Without the heat of the original furnace flue products, the existing vent pipe is probably oversized for the single water heater or other appliance. The vent should be checked for proper draw with the remaining appliance.

The test should be conducted while all appliances (both in operation and those not in operation) are connected to the venting system being tested. If the venting system has been installed improperly, or if provisions have not been made for sufficient amounts of combustion air, corrections must be made as outlined in the previous section.

- 1 - Seal any unused openings in the venting system.
- 2 - Visually inspect the venting system for proper size and

horizontal pitch. Determine there is no blockage or restriction, leakage, corrosion, or other deficiencies which could cause an unsafe condition.

- 3 - To the extent that it is practical, close all building doors and windows and all doors between the space in which the appliances connected to the venting system are located and other spaces of the building.
- 4 - Close fireplace dampers.
- 5 - Turn on clothes dryers and any appliances not connected to the venting system. Turn on any exhaust fans, such as range hoods and bathroom exhausts, so they will operate at maximum speed. Do not operate a summer exhaust fan.
- 6 - Follow the lighting instruction to place the appliance being inspected into operation. Adjust thermostat so appliance will operate continuously.
- 7 - Use the flame of match or candle to test for spillage of flue gases at the draft hood relief opening after 5 minutes of main burner operation.
- 8 - If improper venting is observed during any of the above tests, the venting system must be corrected or sufficient combustion/make-up air must be provided. The venting system should be re-sized to approach the minimum size as determined by using the appropriate tables in appendix G in the current standards of the National Fuel Gas Code ANSI-Z223.1/NPFA 54 in the U.S.A., and the appropriate Natural Gas and Propane appliances venting sizing tables in the current standard of the CSA-B149 Natural Gas and Propane Installation Codes in Canada.
- 9 - After determining that each appliance remaining connected to the common venting system properly vents when tested as indicated in step 3, return doors, windows, exhaust fans, fireplace dampers and any other gas-burning appliance to their previous condition of use.

Other Unit Adjustments

Primary and Secondary Limits

The primary limit is located on the heating compartment vestibule panel. The secondary limits are located in the blower compartment, attached to the back side of the blower. These limits are factory set and require no adjustment.

Flame Rollout Switches (Two)

These manually reset switches are located on the burner box. If tripped, check for adequate combustion air before resetting.

Pressure Switches (Two or Four)

The pressure switches are located in the heating compartment on the combustion air inducer. These switches check for proper combustion air inducer operation before allowing ignition trial. The switches are factory-set and require no adjustment.

Back-Up Secondary Limit (090, 091, 110, 111 & 135)

The back-up secondary limit is located on the combustion air inducer. This switch protects the plastic components from overheating due to indoor blower motor failure. If tripped, check for proper blower operation before resetting.

Temperature Rise

After the furnace has been started and supply and return air temperatures have been allowed to stabilize, check the temperature rise. If necessary, adjust the blower speed to maintain the temperature rise within the range shown on the unit nameplate. Increase the blower speed to decrease the temperature. Decrease the blower speed to increase the temperature rise. Failure to adjust the temperature rise may cause erratic limit operation.

Thermostat Heat Anticipation

Set the heat anticipator setting (if adjustable) according to the amp draw listed on the wiring diagram that is attached to the unit.

Electrical

- 1 - Check all wiring for loose connections.
- 2 - Check for the correct voltage at the furnace (furnace operating).
- 3 - Check amp-draw on the blower motor.
Motor Nameplate _____ Actual _____

NOTE - Do not secure the electrical conduit directly to the air ducts or structure.

Electronic Ignition

The integrated control has an added feature of an internal Watchguard control. The feature serves as an automatic reset device for ignition control lockout caused by ignition failure. This type of lockout is usually due to low gas line pressure. After one hour of continuous thermostat demand for heat, the Watchguard will break and remake thermostat demand to the furnace and automatically reset the control to begin the ignition sequence.

Exhaust and Air Intake Pipe

- 1 - Check exhaust and air intake connections for tightness and to make sure there is no blockage.
- 2 - Are pressure switches closed? Obstructed exhaust pipe will cause unit to shut off at pressure switches. Check termination for blockages.
- 3 - Reset manual flame rollout switches on burner box cover.

Failure To Operate

If the unit fails to operate, check the following:

- 1 - Is the thermostat calling for heat?
- 2 - Are access panels securely in place?
- 3 - Is the main disconnect switch closed?
- 4 - Is there a blown fuse?
- 5 - Is the filter dirty or plugged? Dirty or plugged filters will cause the limit control to shut the unit off.
- 6 - Is gas turned on at the meter?
- 7 - Is the manual main shut-off valve open?
- 8 - Is the internal manual shut-off valve open?
- 9 - Is the unit ignition system in lock out? If the unit locks out again, inspect the unit for blockages.

Heating Sequence of Operation

NOTE - The thermostat selection DIP switch on the control board is factory-set in the "TWO-STAGE" position.

Applications Using a Two-Stage Thermostat

A - Heating Sequence -- Control Board Thermostat Selection DIP switch in "Two-Stage" Position (Factory Setting)

- 1 - On a call for heat, thermostat first-stage contacts close sending a signal to the integrated control. The integrated control runs a self-diagnostic program and checks high temperature limit switches for normally closed contacts and pressure switches for normally open contacts. The combustion air inducer is energized at low speed and the humidifier terminal is energized.
- 2 - Once the control receives a signal that the low-fire pressure switch has closed, the combustion air inducer begins a 15-second pre-purge in low speed.
- 3 - After the pre-purge is complete, a 20-second initial ignitor warm-up period begins. The combustion air inducer continues to operate at low speed.
- 4 - After the 20-second warm-up period has ended, the gas valve is energized on low fire (first stage) and ignition occurs. At the same time, the control module sends a signal to begin an indoor blower 45-second ON-delay. When the delay ends, the indoor blower motor is energized on the low fire heating speed and the 24V humidifier terminal is energized. The furnace will continue this operation as long as the thermostat has a first-stage heating demand.
- 5 - If second-stage heat is required, the thermostat second-stage heat contacts close and send a signal to the integrated control. The integrated control initiates a 30-second second-stage recognition delay.
- 6 - At the end of the recognition delay, the integrated control energizes the combustion air inducer at high speed. The control also checks the high-fire (second stage) pressure switch to make sure it is closed. Once

the the control receives a signal that the high-fire pressure switch is close, the high-fire (second stage) gas valve is energized and the indoor blower motor is energized for operation at the high-fire heating speed.

- 7 - When the demand for high-fire (second stage) heat is satisfied, the combustion air inducer is switched to the low-fire heating speed and the high-fire (second stage) gas valve is de-energized. The low-fire (first stage) gas valve continues operation. The indoor blower motor is switched to the low-fire heating speed.
- 8 - When the thermostat demand for low-fire (first stage) heat is satisfied, the gas valve is de-energized and the field-selected indoor blower off delay begins. The combustion air inducer begins a 5-second post-purge period.
- 9 - When the combustion air post-purge period is complete, the inducer and humidifier terminal are de-energized. The indoor blower is de-energized at the end of the off delay.

Applications Using A Single-Stage Thermostat

B - Heating Sequence -- Control Board Thermostat Selection DIP switch in "Single-Stage" Position

NOTE - In these applications, two-stage heat will be initiated by the integrated control if heating demand has not been satisfied after the field adjustable period (10 or 15 minutes).

- 1 - On a call for heat, thermostat first-stage contacts close sending a signal to the integrated control. The integrated control runs a self-diagnostic program and checks high temperature limit switches for normally closed contacts and pressure switches for normally open contacts. The combustion air inducer is energized at low speed and the 120 VAC humidifier terminal is energized.
- 2 - Once the control receives a signal that the low-fire pressure switch has closed, the combustion air inducer begins a 15-second pre-purge in low speed.
- 3 - After the pre-purge is complete, a 20-second initial ignitor warm-up period begins. The combustion air inducer continues to operate at low speed.
- 4 - After the 20-second warm-up period has ended, the gas valve is energized on low fire (first stage) and ignition occurs. At the same time, the control module sends a signal to begin an indoor blower 45-second ON-delay. When the delay ends, the indoor blower motor is energized on the low-fire heating speed and the 24V humidifier terminal is energized. The integrated control also initiates a second-stage on delay (factory-set at 10 minutes; adjustable to 15 minutes).
- 5 - If the heating demand continues beyond the second-stage on delay, the integrated control energizes the combustion air inducer at high speed. The control also checks the high-fire (second stage) pressure switch to make sure it is closed. Once the control receives a signal the high-fire pressure switch is closed, the high-fire (second stage) gas valve is energized and the indoor blower motor is energized for operation at the high-fire heating speed.
- 6 - When the thermostat heating demand is satisfied, the combustion air inducer begins a 5-second post-purge. The field-selected indoor blower off delay begins.

- 7 - When the combustion air post-purge period is complete, the inducer and humidifier terminal are de-energized. The indoor blower is de-energized at the end of the off delay.

Service

⚠ WARNING

ELECTRICAL SHOCK, FIRE, OR EXPLOSION HAZARD.

Failure to follow safety warnings exactly could result in dangerous operation, serious injury, death or property damage.

Improper servicing could result in dangerous operation, serious injury, death, or property damage.

Before servicing, disconnect all electrical power to furnace.

When servicing controls, label all wires prior to disconnecting. Take care to reconnect wires correctly. Verify proper operation after servicing.

At the beginning of each heating season, system should be checked as follows by a qualified service technician:

Blower

Check the blower wheel for debris and clean if necessary. The blower motors are prelubricated for extended bearing life. No further lubrication is needed.

⚠ WARNING

The blower access panel must be securely in place when the blower and burners are operating. Gas fumes, which could contain carbon monoxide, can be drawn into living space resulting in personal injury or death.

Filters

All G61MPV filters are installed external to the unit. Filters should be inspected monthly. Clean or replace the filters when necessary to ensure proper furnace operation. Table 3 lists recommended filter sizes.

Exhaust and air intake pipes

Check the exhaust and air intake pipes and all connections for tightness and to make sure there is no blockage.

NOTE - After any heavy snow, ice or frozen fog event the furnace vent pipes may become restricted. Always check the vent system and remove any snow or ice that may be obstructing the plastic intake or exhaust pipes.

Electrical

- 1 - Check all wiring for loose connections.
- 2 - Check for the correct voltage at the furnace (furnace operating).
- 3 - Check amp-draw on the blower motor.
Motor Nameplate _____ Actual _____

Winterizing and Condensate Trap Care

- 1 - Turn off power to the unit.

- 2 - Have a shallow pan ready to empty condensate water.
- 3 - Remove the drain plug from the condensate trap and empty water. Inspect the trap then reinstall the drain plug.

Cleaning Heat Exchanger

If cleaning the heat exchanger becomes necessary, follow the below procedures and refer to figure 1 when disassembling unit. Use papers or protective covering in front of furnace while removing heat exchanger assembly.

- 1 - Turn off electrical and gas supplies to the furnace.
- 2 - Remove the upper and lower furnace access panels.
- 3 - Mark all gas valve wires and disconnect them from valve.
- 4 - Remove gas supply line connected to gas valve. Remove gas valve/manifold assembly.
- 5 - Remove sensor wire from sensor. Disconnect 2-pin plug from the ignitor.
- 6 - Disconnect wires from flame roll-out switches.
- 7 - Remove burner box cover and remove four burner box screws at the vestibule panel and remove burner box. Set burner box assembly aside.
NOTE - G61MPV-135 units are secured to the vestibule panel by two additional screws. These screws must be removed for servicing; however it is not necessary to replace the screws.
NOTE - If necessary, clean burners at this time. Follow procedures outlined in Burner Cleaning section.
- 8 - Loosen three clamps and remove flexible exhaust tee.
- 9 - Remove 3/8 inch rubber cap from condensate drain plug and drain. Replace cap after draining.
- 10 - Disconnect condensate drain line from the condensate trap. Remove condensate trap (it may be necessary to cut drain pipe). Remove screws that secure condensate collars to either side of the furnace and remove collars. Remove drain tubes from cold end header collector box.
- 11 - Disconnect condensate drain tubing from flue collar. Remove screws that secure both flue collars into place. Remove flue collars. It may be necessary to cut the exiting exhaust pipe for removal of the fittings.
- 12 - Mark and disconnect all combustion air pressure tubing from cold end header collector box.
- 13 - Mark and remove wires from pressure switches. Remove pressure switches. Keep tubing attached to pressure switches.
- 14 - Disconnect the 3-pin plug from the combustion air inducer. Disconnect the two wires to the backup secondary limit, if applicable. Remove four screws which secure combustion air inducer to collector box. Remove combustion air inducer assembly. Remove ground wire from vest panel.
- 15 - Remove electrical junction box from the side of the furnace.

- 16 - Mark and disconnect any remaining wiring to heating compartment components. Disengage strain relief bushing and pull wiring and bushing through the hole in the blower deck.
- 17 - Remove the primary limit from the vestibule panel.
- 18 - Remove two screws from the front cabinet flange at the blower deck. Spread cabinet sides slightly to allow clearance for removal of heat exchanger.
- 19 - Remove screws along vestibule sides and bottom which secure vestibule panel and heat exchanger assembly to cabinet. Remove two screws from blower rail which secure bottom heat exchanger flange. Remove heat exchanger from furnace cabinet.
- 20 - Back wash heat exchanger with soapy water solution or steam. **If steam is used it must be below 275°F (135°C) .**
- 21 - Thoroughly rinse and drain the heat exchanger. Soap solutions can be corrosive. Take care to rinse entire assembly.
- 22 - Reinstall heat exchanger into cabinet making sure that the clamshells of the heat exchanger assembly are resting on the support located at the rear of the cabinet. Remove the indoor blower to view this area through the blower opening.
- 23 - Re-secure the supporting screws along the vestibule sides and bottom to the cabinet.
- 24 - Reinstall cabinet screws on front flange at blower deck.
- 25 - Reinstall the primary limit on the vestibule panel.
- 26 - Route heating component wiring through hole in blower deck and reinsert strain relief bushing.
- 27 - Reinstall electrical junction box.
- 28 - Reinstall the combustion air inducer. Reconnect the 3-pin plug to the wire harness. Reconnect the two wires to the backup secondary limit, if applicable.
- 29 - Reinstall pressure switches and reconnect pressure switch wiring.
- 30 - Carefully connect combustion air pressure switch hosing from pressure switches to proper stubs on cold end header collector box.
- 31 - Reinstall condensate collars on each side of the furnace. Reconnect drain tubing to collector box.
- 32 - Reinstall condensate trap on same side as exhaust pipe. Reconnect condensate drain line to the condensate trap.
- 33 - Use securing screws to reinstall flue collars to either side of the furnace. Reconnect exhaust piping and exhaust drain tubing.
- 34 - Replace flexible exhaust tee on combustion air inducer and flue collars. Secure using three existing hose clamps.
- 35 - Reinstall burner box assembly in vestibule area.
- 36 - Reconnect flame roll-out switch wires.
- 37 - Reconnect sensor wire and reconnect 2-pin plug from ignitor.

- 38 - Secure burner box assembly to vestibule panel using four existing screws. **Make sure burners line up in center of burner ports.**
- 39 - Reinstall gas valve manifold assembly. Reconnect gas supply line to gas valve.
- 40 - Reinstall burner box cover.
- 41 - Reconnect wires to gas valve.
- 42 - Replace the blower compartment access panel.
- 43 - Refer to instruction on verifying gas and electrical connections when re-establishing supplies.
- 44 - Follow lighting instructions to light and operate furnace for 5 minutes to ensure that heat exchanger is clean and dry and that furnace is operating properly.
- 45 - Replace heating compartment access panel.

Cleaning the Burner Assembly

- 1 - Turn off electrical and gas power supplies to furnace. Remove upper and lower furnace access panels.
- 2 - Mark all gas valve wires and disconnect them from the valve.
- 3 - Disconnect the gas supply line from the gas valve. Remove gas valve/manifold assembly.
- 4 - Mark and disconnect sensor wire from the sensor. Disconnect 2-pin plug from the ignitor at the burner box.
- 5 - Remove burner box cover and remove four screws which secure burner box assembly to vest panel. Remove burner box from the unit.
NOTE - G61MPV-135 units are secured to the vestibule panel by two additional screws. These screws must be removed for servicing; however it is not necessary to replace the screws.
- 6 - Use the soft brush attachment on a vacuum cleaner to gently clean the face of the burners. Visually inspect the inside of the burners and crossovers for any blockage caused by foreign matter. Remove any blockage.
- 7 - Reconnect the sensor wire and reconnect the 2-pin plug to the ignitor wiring harness.
- 8 - Reinstall the burner box assembly using the existing four screws. Make sure that the burners line up in the center of the burner ports.
- 9 - Reinstall the gas valve manifold assembly. Reconnect the gas supply line to the gas valve. Reinstall the burner box cover.
- 10 - Reconnect the gas valve wires to the gas valve.
- 11 - Replace the blower compartment access panel.
- 12 - Refer to instruction on verifying gas and electrical connections when re-establishing supplies.

- 13 - Follow lighting instructions to light and operate furnace for 5 minutes to ensure that heat exchanger is clean and dry and that furnace is operating properly.
- 14 - Replace heating compartment access panel.

Planned Service

A service technician should check the following items during an annual inspection. Power to the unit must be shut off for safety.

Fresh air grilles and louvers (on the unit and in the room where the furnace is installed) - Must be open and unobstructed to provide combustion air.

Burners - Must be inspected for rust, dirt, or signs of water.

Vent pipe - Must be inspected for signs of water, damaged, cracked or sagging pipe, or disconnected joints.

Unit appearance - Must be inspected for rust, dirt, signs of water, burnt or damaged wires, or components.

Blower access door - Must be properly in place and provide a seal between the return air and the room where the furnace is installed.

Return air duct - Must be properly attached and provide an air seal to the unit.

Operating performance - Unit must be observed during operation to monitor proper performance of the unit and the vent system.

Combustion gases - Flue products must be analyzed and compared to the unit specifications.

Problems detected during the inspection may make it necessary to temporarily shut down the furnace until the items can be repaired or replaced.

Instruct the homeowners to pay attention to their furnace. Situations can arise between annual furnace inspections that may result in unsafe operation. For instance, items innocently stored next to the furnace may obstruct the combustion air supply. This could cause incomplete combustion and the production of carbon monoxide gas.

Ignition Control Board Diagnostic Codes (Red LED)

FLASH CODE (X + Y)	STATUS / ERROR DESCRIPTION
FLASH CODE DESCRIPTIONS	
Pulse	A 1/4 second flash followed by four seconds of off time.
Heartbeat	Constant 1/2 second bright and 1/2 second dim cycles.
X + Y	LED flashes X times at 2Hz, remains off for two seconds, flashes Y times at 2Hz, remains off for four seconds, then repeats.
Pulse	Power on - Standby.
Heartbeat	Normal operation - signaled when heating demand initiated at thermostat.
FLAME CODES	
1 + 2	Low flame current -- run mode.
1 + 3	Flame sensed out of sequence -- flame still present.
PRESSURE SWITCH CODES	
2 + 3	Low pressure switch failed open.
2 + 4	Low pressure switch failed closed.
2 + 5	High pressure switch failed open.
2 + 6	High pressure switch failed closed.
2 + 7	Low pressure switch opened during ignition trial or heating demand.
LIMIT CODE	
3 + 1	Limit switch open.
WATCHGUARD CODES	
4 + 1	Watchguard -- Exceeded maximum number of retries.
4 + 2	Watchguard -- Exceeded maximum number of retries or last retry was due to pressure switch opening.
4 + 3	Watchguard -- Exceeded maximum number of retries or last retry was due to flame failure.
4 + 5	Watchguard -- Limit remained open longer than three minutes.
4 + 6	Watchguard -- Flame sensed out of sequence; flame signal gone.
4 + 7	Ignitor circuit fault -- Failed ignitor or triggering circuitry.
4 + 8	Low line voltage.
HARD LOCKOUT CODES	
5 + 1	Hard lockout -- Rollout circuit open or previously opened.
5 + 2	Control failed self check, internal error (control will restart if error recovers).
5 + 3	No Earth ground (control will restart if error recovers).
5 + 4	Reversed line voltage polarity (control will restart if the error recovers).
5 + 6	Low secondary (24VAC) voltage.

Troubleshooting: Heating Sequence of Operation

HEATING SEQUENCE OF OPERATION NORMAL AND ABNORMAL HEATING MODE

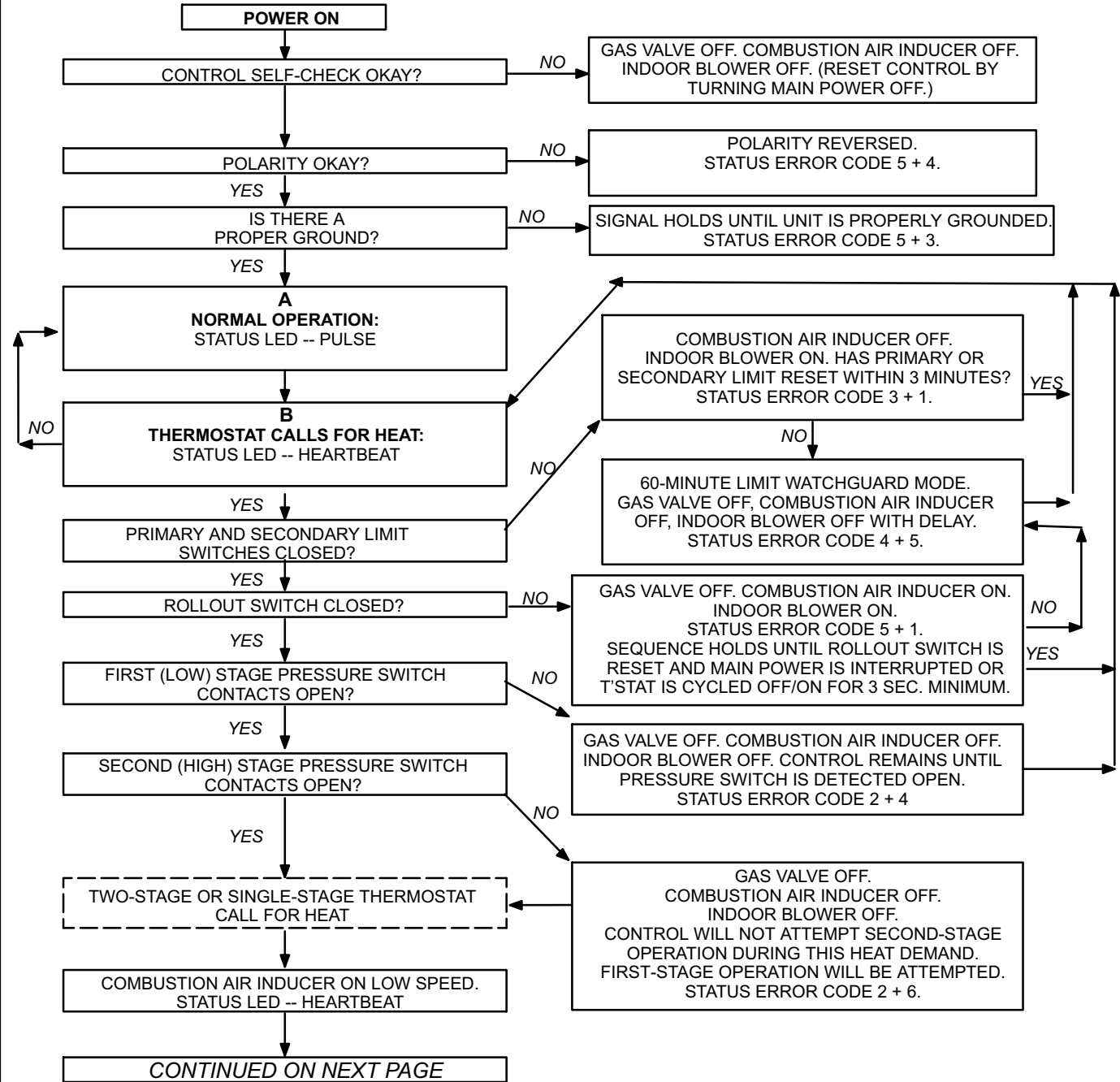

Troubleshooting: Heating Sequence of Operation (Continued)

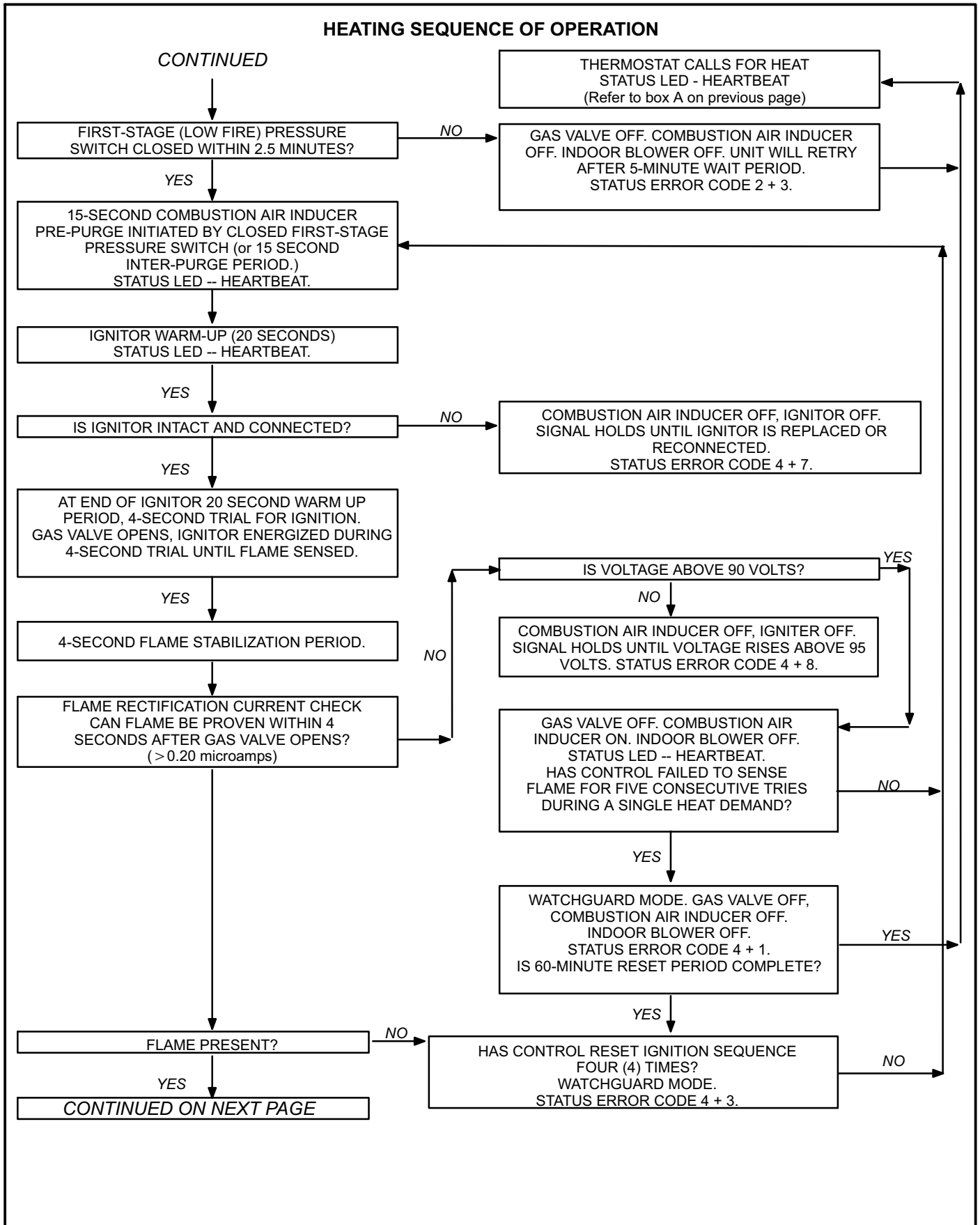

Troubleshooting: Heating Sequence of Operation (Continued)

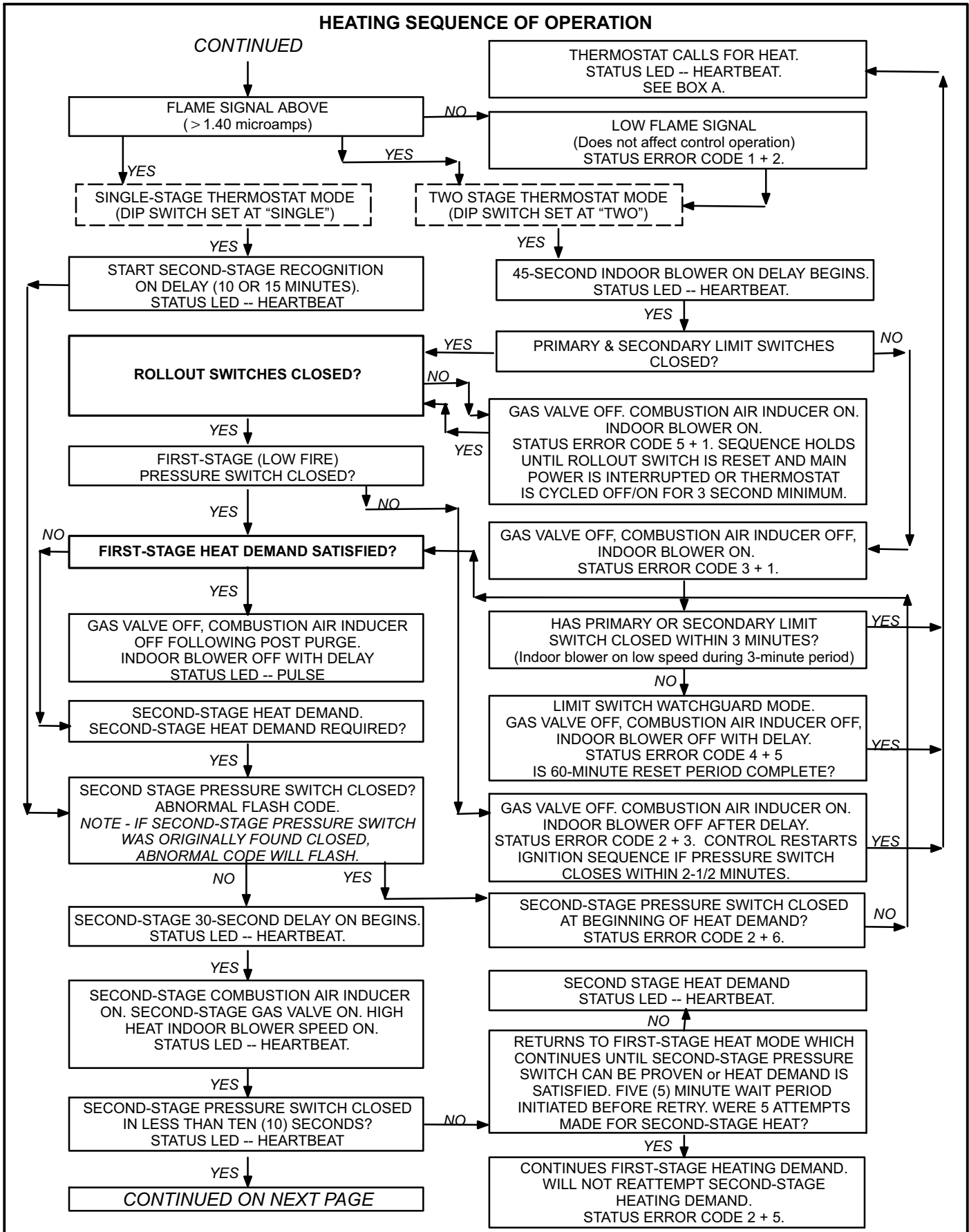

Troubleshooting: Heating Sequence of Operation (Continued)

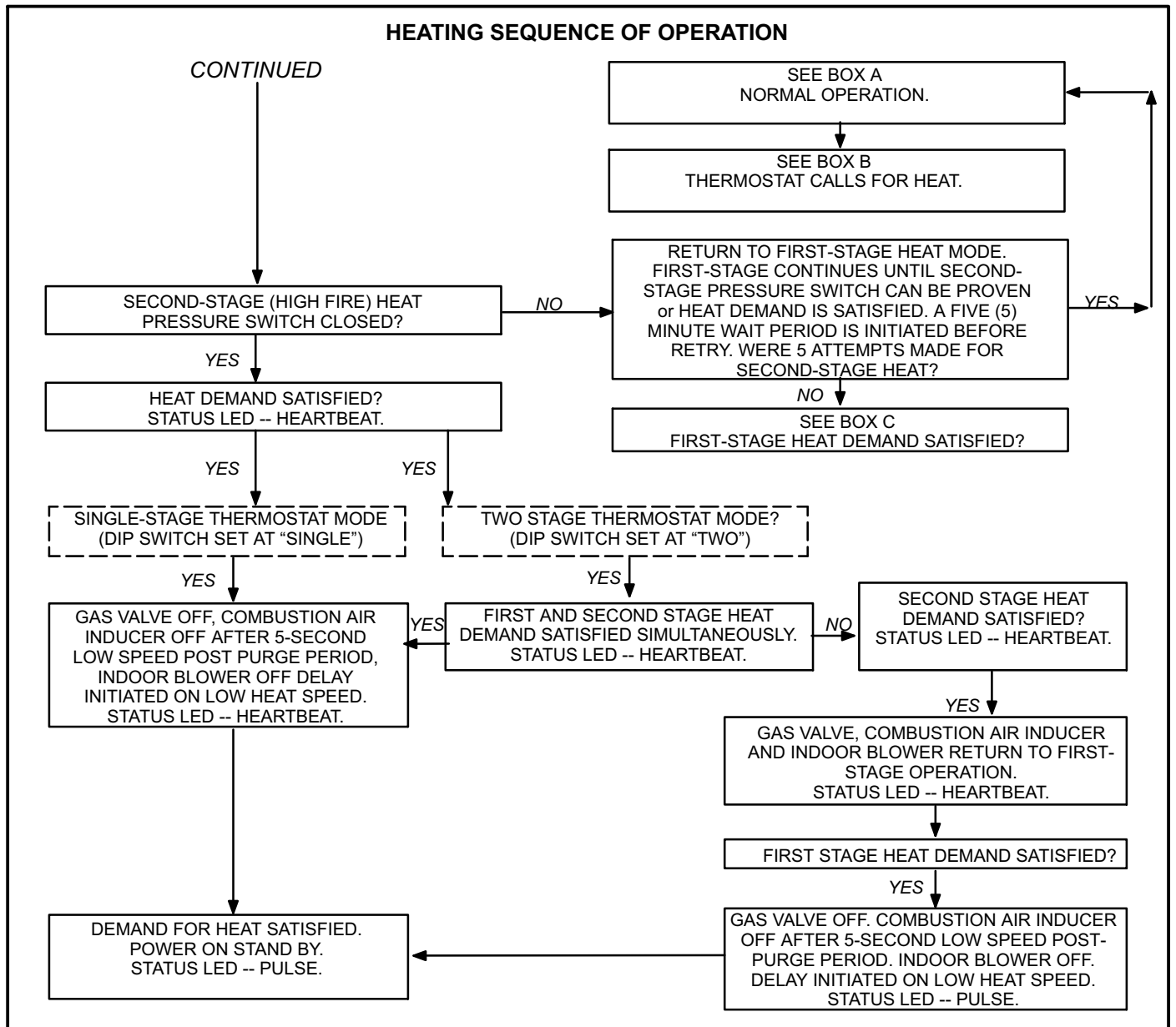

Troubleshooting: Cooling Sequence of Operation

COOLING SEQUENCE OF OPERATION

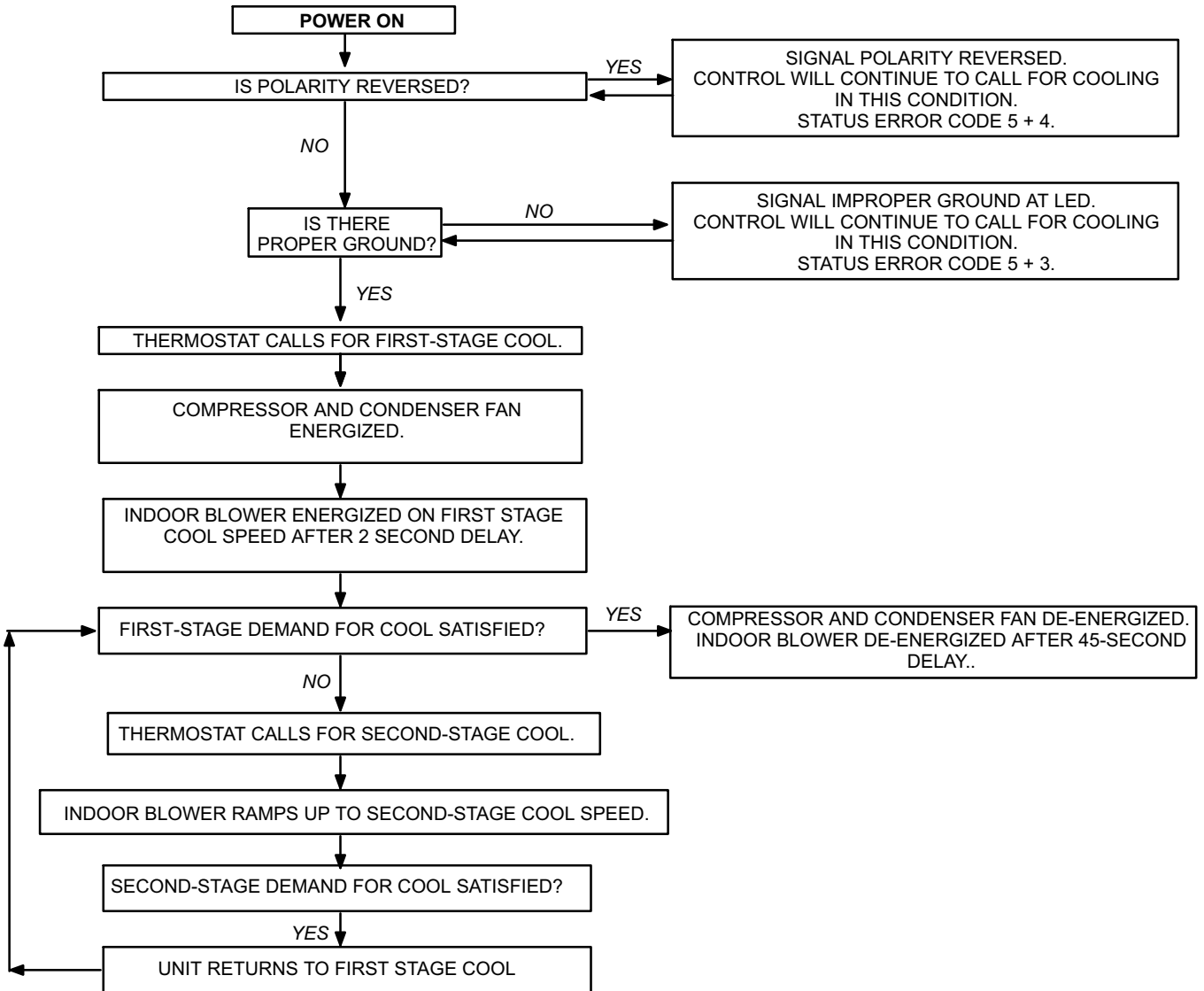

Troubleshooting: Continuous Fan Sequence of Operation

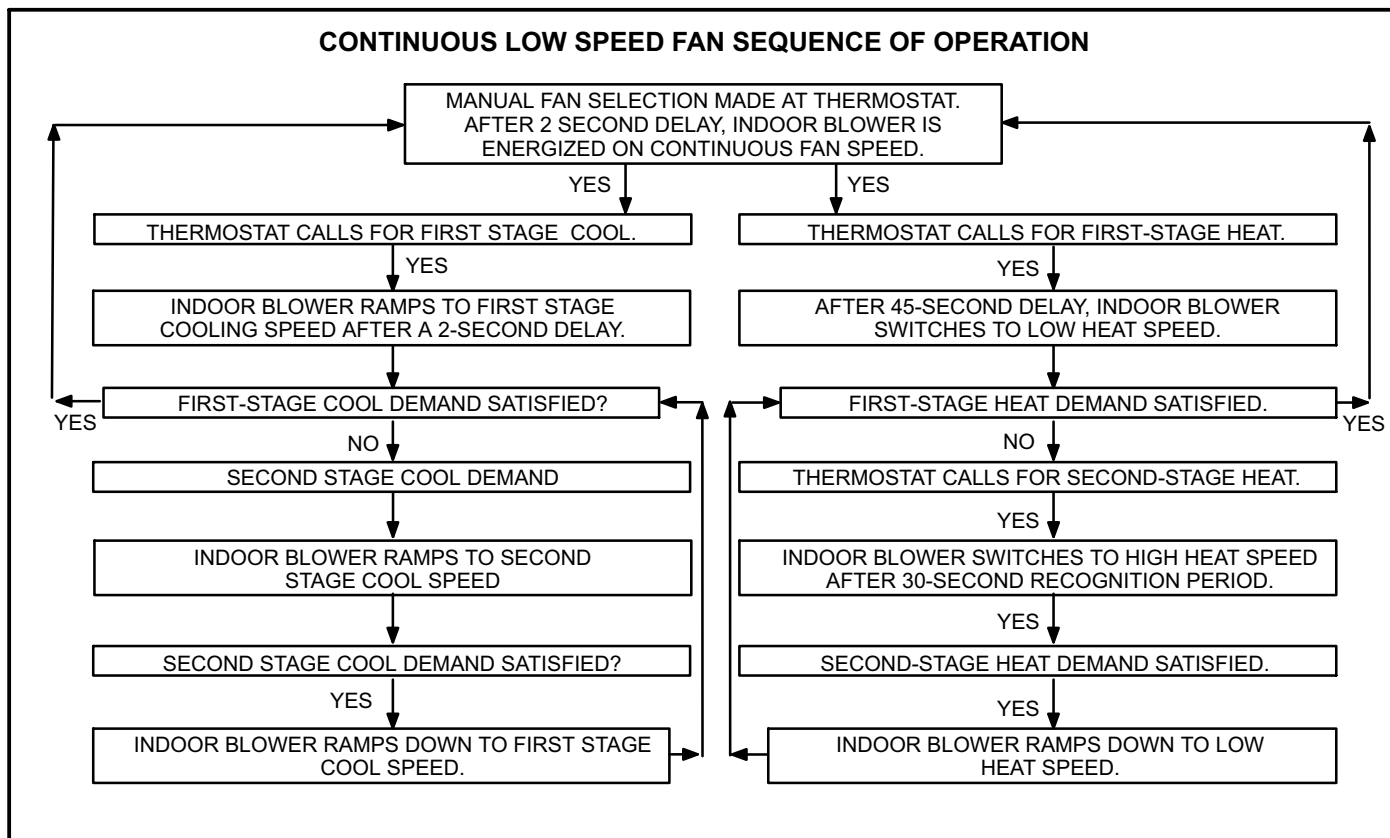

Repair Parts List

The following repair parts are available through Lennox dealers. When ordering parts, include the complete furnace model number listed on the CSA nameplate -- Example: G61MPV-36B-070-7. **All service must be performed by a licensed professional installer (or equivalent), service agency, or gas supplier.**

Cabinet Parts

- Upper access panel
- Blower access panel
- Top Cap

Control Panel Parts

- Transformer
- Integrated control board
- Door interlock switch
- Circuit Breaker

Blower Parts

- Blower wheel
- Motor
- Motor mounting frame
- Power choke (1 hp only)
- Blower housing cutoff plate

Heating Parts

- Flame Sensor
- Heat exchanger assembly
- Gas manifold
- Combustion air inducer
- Gas valve
- Main burner cluster
- Main burner orifices
- Pressure switches
- Ignitor
- Primary limit control
- Secondary limit control
- Flame rollout switches
- Combustion air inducer auxiliary limit

Vent Pipe Sizing Worksheet

Step 1	Proposed vent pipe size : _____	Equivalent Feet
Step 2	Termination kit catalog number : _____ Vent pipe equivalency value from table 5 : _____	
Step 3	Total number of 90° elbows required (indoors and outdoors) _____ X 5 = _____ equivalent feet of pipe	
Step 4	Total number of 45° elbows required (indoors and outdoors) _____ X 2.5 = _____ equivalent feet of pipe	
Step 5	Linear feet of straight pipe required : _____	
Step 6	Add equivalent feet of vent pipe listed in steps 2 through 5.	TOTAL

If the total is equal to, or less than, the allowable maximum given in table 7, the proposed pipe size is acceptable. If the total exceeds the maximum allowed vent pipe length, repeat the process above using the next larger diameter pipe until an acceptable total is achieved.

NOTE - In Direct Vent systems, total the equivalent length of either the exhaust OR intake piping run, depending upon which will be LONGER. Intake and exhaust pipe diameter must be the same size and must be terminated in the same pressure zone. Intake and exhaust pipe should be roughly the same length.

G61MPV Start-Up & Performance Check List

Job Name _____ Job No. _____ Date _____
Job Location _____ City _____ State _____
Installer _____ City _____ State _____
Unit Model No. _____ Technician _____
Serial No. _____

Heating Section

Electrical Connections Tight?
Supply Voltage _____ Blower Motor H.P. _____
Blower Motor Amps Gas Piping Connections
Tight & Leak-Tested?
Fuel Type: Natural Gas? LP/Propane Gas?
Furnace Btu Input _____
Line Pressure _____
Regulator Pressure _____ w.c. - Nat.: _____ w.c. - LP/Propane
Flue Connections Tight? Proper Draft?
Condensate Connections Tight?
Combustion Gas Tested? CO₂ CO
Fan Control Setting
(45 Seconds Fixed On) _____
Fan Control Off Setting _____ Temperature Rise _____
Filter Clean & Secure? Vent Clear?

Thermostat

Calibrated? Heat Anticipator Properly Set? Level?

Requirements for Commonwealth of Massachusetts

Modifications to NFPA-54, Chapter 10

Revise NFPA-54 section 10.8.3 to add the following requirements:

For all side wall, horizontally vented, gas-fueled equipment installed in every dwelling, building or structure used in whole or in part for residential purposes, including those owned or operated by the Commonwealth and where the side wall exhaust vent termination is less than seven (7) feet above the finished grade in the area of the venting, including but not limited to decks and porches, the following requirements shall be satisfied:

- 1 - **INSTALLATION OF CARBON MONOXIDE DETECTORS.** At the time of installation of the side wall, horizontally vented, gas-fueled equipment, the installing plumber or gasfitter shall observe that a hard-wired carbon monoxide detector with an alarm and battery backup is installed on the floor level where the gas equipment is to be installed. In addition, the installing plumber or gasfitter shall observe that a battery-operated or hard-wired carbon monoxide detector with an alarm is installed on each additional level of the dwelling, building or structure served by the side wall, horizontally vented, gas-fueled equipment. It shall be the responsibility of the property owner to secure the services of qualified licensed professionals for the installation of hard-wired carbon monoxide detectors.
 - a - In the event that the side wall, horizontally vented, gas-fueled equipment is installed in a crawl space or an attic, the hard-wired carbon monoxide detector with alarm and battery back-up may be installed on the next adjacent floor level.
 - b - In the event that the requirements of this subdivision cannot be met at the time of completion of installation, the owner shall have a period of thirty (30) days to comply with the above requirements; provided, however, that during said thirty (30) day period, a battery-operated carbon monoxide detector with an alarm shall be installed.
- 2 - **APPROVED CARBON MONOXIDE DETECTORS.** Each carbon monoxide detector as required in accordance with the above provisions shall comply with NFPA 720 and be ANSI/UL 2034 listed and IAS certified.
- 3 - **SIGNAGE.** A metal or plastic identification plate shall be permanently mounted to the exterior of the building at a minimum height of eight (8) feet above grade directly in line with the exhaust vent terminal for the horizontally vented, gas-fueled heating appliance or equipment. The sign shall read, in print size no less than one-half (1/2) inch in size, "GAS VENT DIRECTLY BELOW. KEEP CLEAR OF ALL OBSTRUCTIONS."

- 4 - **INSPECTION.** The state or local gas inspector of the side wall, horizontally vented, gas-fueled equipment shall not approve the installation unless, upon inspection, the inspector observes carbon monoxide detectors and signage installed in accordance with the provisions of 248 CMR 5.08(2)(a) 1 through 4.

EXEMPTIONS: The following equipment is exempt from 24 CMR 5.08(2)(a) 1 through 4:

- 1 - The equipment listed in Chapter 10 entitled "Equipment Not Required to Be Vented" in the most current edition of NFPA 54 as adopted by the Board; and
- 2 - Product Approved side wall, horizontally vented, gas-fueled equipment installed in a room or structure separate from the dwelling, building or structure used in whole or in part for residential purposes.

MANUFACTURER REQUIREMENTS - GAS EQUIPMENT VENTING SYSTEM PROVIDED.

When the manufacturer of Product Approved side wall, horizontally vented, gas-fueled equipment provides a venting system design or venting system components with the equipment, the instructions provided by the manufacturer for installation of the equipment and the venting system shall include:

- 1 - Detailed instructions for the installation of the venting system design or the venting system components: and
- 2 - A complete parts list for the venting system design or venting system.

MANUFACTURER REQUIREMENTS - GAS EQUIPMENT VENTING SYSTEM NOT PROVIDED.

When the manufacturer of Product Approved side wall, horizontally vented, gas-fueled equipment does not provide the parts for venting the flue gases, but identifies "special venting systems," the following requirements shall be satisfied by the manufacturer:

- 1 - The referenced "special venting system" instructions shall be included with the appliance or equipment installation instructions; and
- 2 - The "special venting systems" shall be Product Approved by the Board, and the instructions for that system shall include a parts list and detailed installation instructions.

A copy of all installation instructions for all Product Approved side wall, horizontally vented, gas-fueled equipment, all venting instructions, all parts lists for venting instructions, and/or all venting design instructions shall remain with the appliance or equipment at the completion of the installation.