

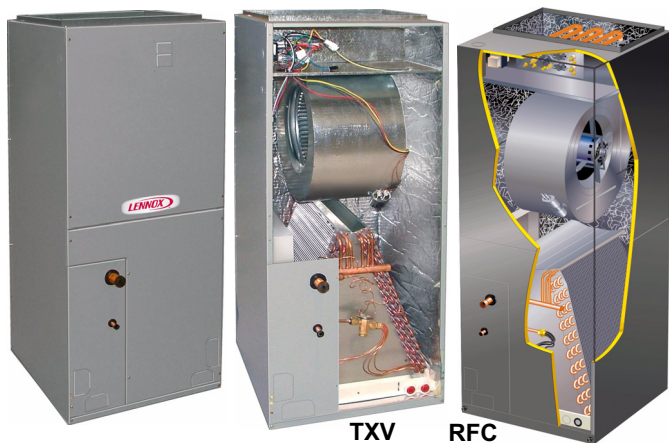

©2011 Lennox Industries Inc.  
Dallas, Texas, USA

# INSTALLATION INSTRUCTIONS

## CB(X)26UH(-R) Series Units



AIR HANDLERS  
505,059M (65937170)  
07/11  
Supersedes 05/11

TPD Technical  
Publications  
Litho U.S.A.

### Table of Contents

Shipping and Packing List	1
Unit Dimensions	2
CB(X)26UH Series Units	3
Requirements	3
Installation Clearances	4
Installation	4
Condensate Drain	7
Duct System and Filters	8
Connecting Refrigerant Lines	9
Sealing the Unit	9
Electrical Connections	9
Airflow - Cooling Blower Speed	12
Check-Out Procedures	15
Operation	15
Maintenance	16
Accessories	16
Cabinet Insulation	16

**RETAIN THESE INSTRUCTIONS  
FOR FUTURE REFERENCE**

### **⚠ WARNING**

Improper installation, adjustment, alteration, service or maintenance can cause property damage, personal injury or loss of life. Installation and service must be performed by a qualified installer or service agency.

### **⚠ CAUTION**

Physical contact with metal edges and corners while applying excessive force or rapid motion can result in personal injury. Be aware of, and use caution when working near these areas during installation or while servicing this equipment.

### **⚠ IMPORTANT**

The Clean Air Act of 1990 bans the intentional venting of refrigerant (CFCs and HCFCs and HFCs) as of July 1, 1992. Approved methods of recovery, recycling or reclaiming must be followed. Fines and/or incarceration may be levied for noncompliance.

### **⚠ IMPORTANT**

This unit must be matched with an outdoor unit as specified in Lennox Engineering Handbook.

### Shipping and Packing List

**Package 1 of 1 contains the following:**

1 - Assembled air handler unit for upflow or horizontal air discharge application (includes upflow and horizontal drain pans)

*NOTE — For downflow application, order kit 12W61 (0658731-75).*

Check equipment for shipping damage. If found, immediately report damage to the last carrier. Check the unit rating plate to confirm that delivered unit matches order.

### **⚠ WARNING**

Product contains fiberglass wool.

Disturbing the insulation in this product during installation, maintenance, or repair will expose you to fiberglass wool. Breathing this may cause lung cancer. (Fiberglass wool is known to the State of California to cause cancer.)

Fiberglass wool may also cause respiratory, skin, and eye irritation.

To reduce exposure to this substance or for further information, consult material safety data sheets available from address shown below, or contact your supervisor.

Lennox Industries Inc.  
P.O. Box 799900  
Dallas, TX 75379-9900



**CB(X)26UH Unit Dimensions - inches (mm)**

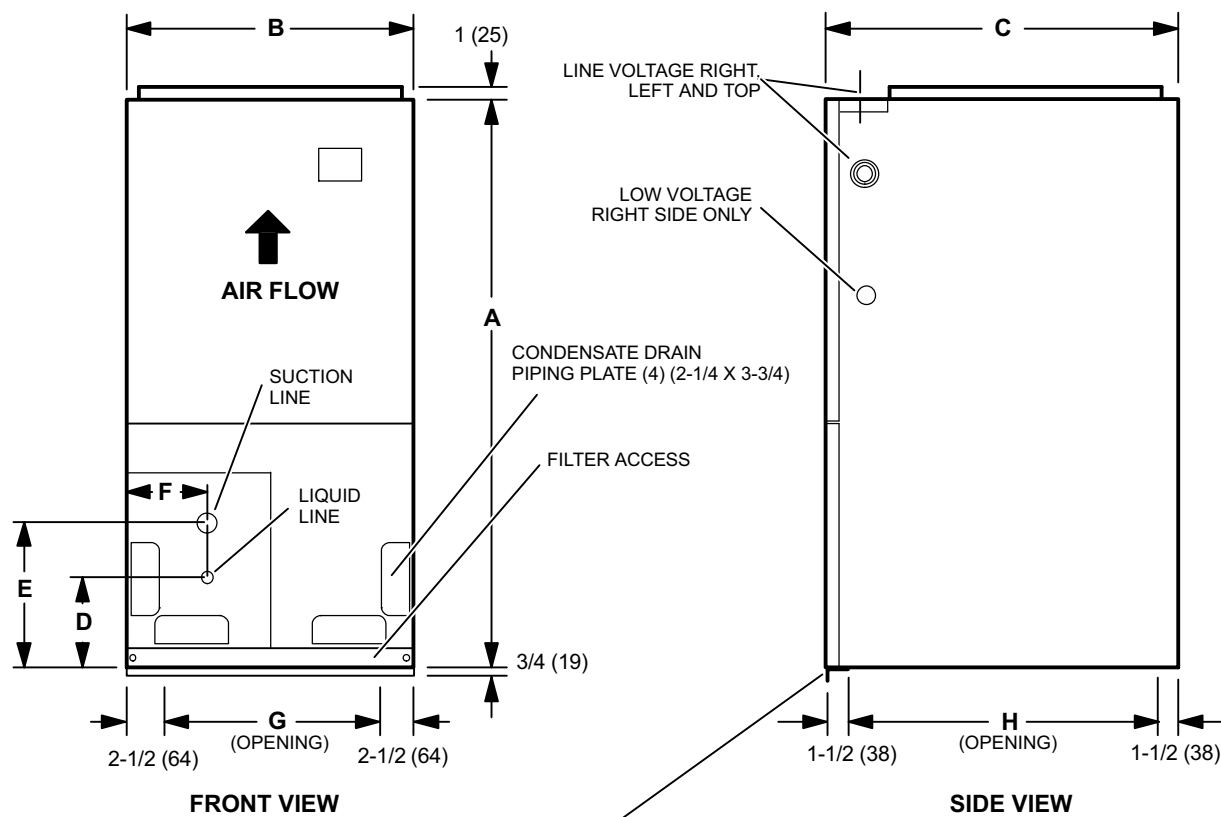

OPTIONAL DUCT ADAPTOR KIT (KIT ALLOWS DIRECT CONNECTION OF THE DUCTWORK TO THE RETURN AIR OPENING OF THE AIR HANDLER, NOT REQUIRED IF AN EXTERNAL FILTER IS USED.)

CB(X)26UH Dimensions (for Upflow and LH/RH Horizontal Air Discharge Applications)									
Dimension	-018, -024		-030, -036		-037*, -042, -048*		-060		
	inches	mm	inches	mm	inches	mm	inches	mm	
<b>A</b>	46-3/4	1187	51	1295	54	1372	60	1524	
<b>B</b>	18-1/2	470	21-1/4	540	21-1/4	540	21-1/4	540	
<b>C</b>	22	559	22	559	26	660	26	660	
<b>D</b>	11	279	12-1/2	318	12	305	11-3/4	298	
<b>E</b>	16	406	18-1/2	470	16-3/4	425	17	432	
<b>F</b>	5-1/2	140	6	152	4	102	4	102	
<b>G</b>	13-1/2	343	16	406	16	406	16	406	
<b>H</b>	19	483	19	483	23	584	23	584	
<b>Supply Air Opening</b>	Depth	17	432	17	432	21	533	21	533
	Width	16-1/2	419	19-1/4	489	19-1/4	489	19-1/4	489
<b>Return Air Opening</b>	Depth	18-1/4	464	18-1/4	464	22-1/4	565	22-1/4	565
	Width	13-1/2	343	16-1/4	413	16-1/4	413	16-1/4	413

\* -037 and -048 units not available in RFC model.

## CB(X)26UH Series Air Handlers

All CB(X)26UH air handlers are designed for indoor installation only. As shipped, the units are ready for installation in either upflow or horizontal left-hand air discharge applications. All units may be installed with optional field-installed electric heat and a matched remote outdoor unit.

- CBX26UH air handlers may be installed with a matched **HFC-410A** remote outdoor unit. These units are completely assembled, including a factory installed check/expansion valve.
- CB26UH air handlers may be installed with a matched **HCFC-22** remote outdoor unit. These units are completely assembled, including a factory installed check/expansion valve.

**Table 1. Orifice (RFC) Part Number (Sizes - in.)**

Model	HCFC-22 NOTE 1	HFC-410A NOTE 2
	13HPD / HP13	XC13 / XP13
018	100484-08 (0.057)	Refer to orifice table in outdoor unit installation manual
024	100484-11 (0.061)	
030	100484-21 (0.072)	
036	100484-23 (0.074)	
042	100484-30 (0.082)	
037, 048	not supported	
060	100484-44 (0.098)	
	Note 1 - Orifice ships with Air Handler.	Note 2 - Orifice ships with outdoor units.

- CB26UH-R (RFC) units may be installed with a matched remote 13HPD/ HP13 outdoor unit. These units are equipped with an HCFC-22 refrigerant flow control device (see orifice table 1). Also, these units can be used with HCFC-22 (13ACD/AC13), or HFC-410A refrigerant provided the RFC shipped with the outdoor unit is installed in place of the RFC device shipped with the CB26UH-R unit.

## Requirements

**⚠ WARNING**

**Excessive Weight Hazard - Use two or more people when moving and installing the unit. Failure to do so can result in back or other type of injury.**

These instructions are intended as a general guide and do not supersede local or national codes in any way. Consult authorities having jurisdiction before installation.

Compliance with all local, state, or national codes pertaining to this type of equipment should be determined prior to installation. Read this instruction manual, as well as the instructions supplied in separate equipment, before starting the installation.

In addition to conforming to manufacturer's installation instructions and local municipal building codes, installation of Lennox air handler units (with or without optional electric heat), MUST conform with National Fire Protection Association (NFPA) standards: "Standard for Installation

of Air Conditioning and Ventilation Systems" (NFPA No. 90A) and "Standard for Installation of Residence Type Warm Air Heating and Air Conditioning Systems" (NFPA No. 90B).

**⚠ IMPORTANT**

The CB(X)26UH units are designed to match, and must be used with, outdoor units as rated. The indoor sections are manufactured with a check/expansion valve (TXV) or refrigerant flow control (RFC) device to provide optimum refrigerant control and system performance with a variety of different capacities of outdoor units.

**TXV units**—In some cases, the rating of the outdoor unit may require that the coil assembly installed TXV be changed to obtain rated performance.

All models are designed for indoor installation only. The installation of the air handler, field wiring, duct system, etc. must conform to the requirements of the National Electrical Code, ANSI/NFPA No. 70 (latest edition) in the United States, and any state laws, and local ordinances (including plumbing or wastewater codes). Local authorities having jurisdiction should be consulted before installation is made. Such applicable regulations or requirements take precedence over the general instructions in this manual. Install the conditioned air plenum, ducts and air filters (not provided) in accordance with NFPA 90B Standard for the Installation of Warm Air Heating and Air-Conditioning Systems (latest edition).

The air handler is shipped from the factory completely assembled. The unit is provided with flanges for the connection of the duct system.

Do not remove the cabinet knockouts until it has been determined which knockouts will need to be removed for the installation.

Select the final air discharge position which best suits the site conditions. Consider required clearances, space, routing requirements for refrigerant line, condensate disposal, filters, duct system, wiring, and accessibility for service. Refer to the air handler rating plate on the air handler for specific information.

**⚠ WARNING**

**Danger of explosion. Keep flammable materials and vapors, such as gasoline, away from air handler. Place air handler so that heating elements are at least 18 inches (46 cm) above the floor for a garage installation. Failure to follow these instructions can result in death, explosion, or fire.**

**NOTES —**

*During cooling operation, excessive sweating may occur if the air handler is installed in a very humid space.*

*If installed in an unconditioned space, sealant should be applied around the electrical wires, refrigerant tubing, and condensate lines where they enter the cabinet.*

*Electrical wires should be sealed on the inside where they exit the conduit opening. Sealant is required to prevent air leakage into, and condensate from forming inside of, the air handler, the control box, and on the electrical controls.*

This unit is approved for installation clearance to combustible material as stated on the unit rating plate. Accessibility and service clearances must take precedence over combustible material clearances.

The air handler must be installed so that free access is allowed to the coil/filter compartment and blower/control compartment.

Horizontal applications of the air handler must be installed sloped (approximately 5/8 inch) toward the drain pan openings to ensure proper condensate drainage.

## Installation Clearances

### NON-DUCTED RETURN CLOSET INSTALLATION

The air handler can be installed in a closet with a false bottom to form a return air plenum. It may also be installed with a return air plenum under the air handler.

Louvers or return air grilles are field-supplied. Local codes may limit application of systems without a ducted return to single story buildings.

When a CB(X)26UH unit is installed in a closet with a louvered return opening, the minimum open area for the louvers will be:

- 320 square inches for -018 and -024 models;
- 360 square inches for -030 and -036 models;
- 450 square inches for -042 thru -060 models.

If the free area is not known, assume a 25% free area for wood or a 75% free area for metal louvers or grilles. Using the louver dimensions and the 25% or 75% assumption, determine if the open area meets the minimum open area listed above.

If a return air plenum is used, the return air grille should be immediately in front of the opening in the plenum to allow for the free flow of return air. When not installed in front of the opening, there must be adequate clearance around the air handler to allow for the free flow of return air.

## Installation

### GENERAL INFORMATION

## ⚠ WARNING

Improper installation, adjustment, alteration, service or maintenance can cause property damage, personal injury or loss of life. Installation and service must be performed by a qualified installer or service agency.

CB(X)26UH units are factory-assembled and configured for installation in upflow or horizontal left-hand air discharge applications.

Each unit consists of a blower assembly, refrigerant coil, and controls, in an insulated galvanized steel factory finished enclosure. Knockouts are provided for electrical wiring entrance.

For ease in installation, it is best to make any necessary coil configuration changes before setting air handler in place.

If a filter is to be installed at the air handler, early models require a filter rack be formed using factory-supplied flanges. Lay the unit on its back and pry out the filter rack tabs as shown in figure 1. Repeat procedure on opposite side.

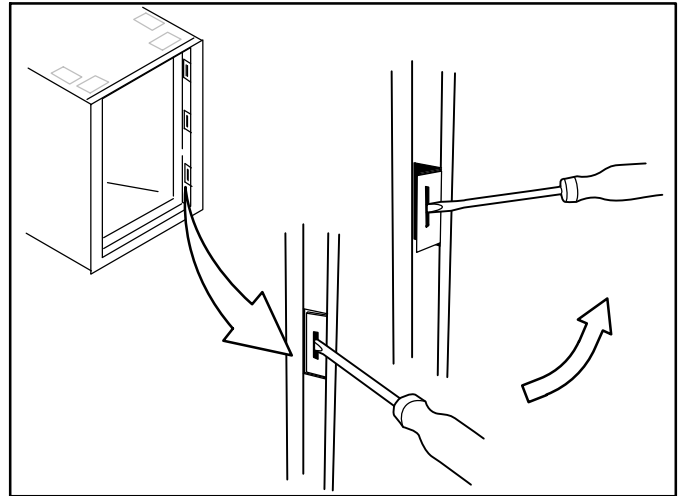

Figure 1. Filter Rack Tabs (Pre April 2006)

Later models are equipped with rails in which the filter slides. Two screws and a bracket must be removed to insert and remove the filter (see figure 2).

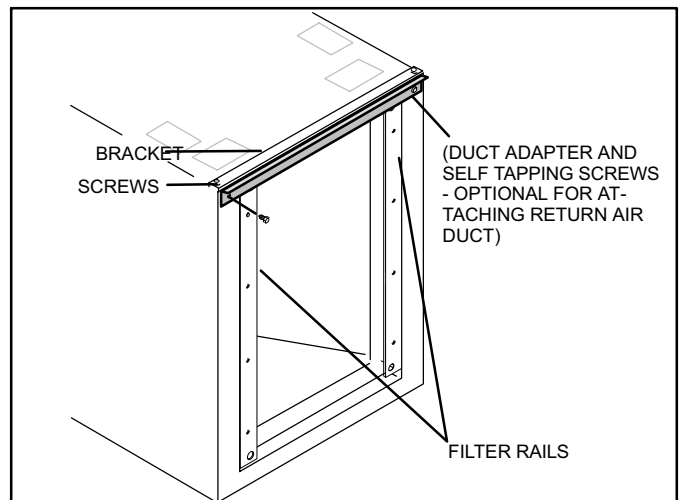
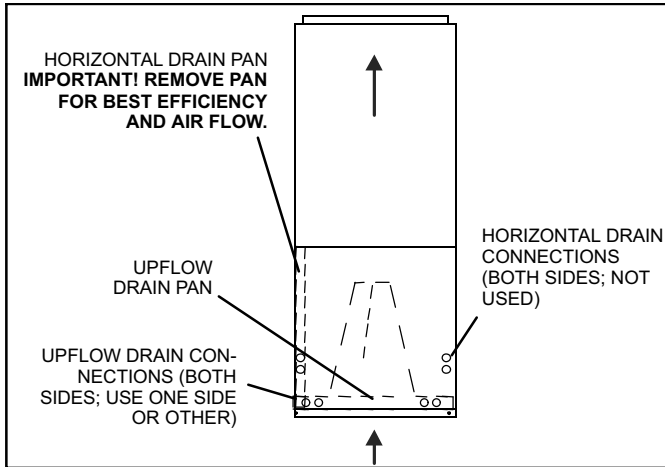

Figure 2. Filter Rails (April 2006 and Later)

### UPFLOW APPLICATION

1. The air handler must be supported on the bottom only and set on solid floor or field-supplied support frame. Securely attach the air handler to the floor or support frame.
2. If installing a unit in an upflow application, remove the horizontal drain pan. **IMPORTANT - The horizontal drain pan is not required in upflow air discharge installations; its removal provides the best efficiency and air flow.**
3. Place the unit in the desired location and level it. Connect return and supply air plenums as required using sheet metal screws.

4. Install units that have no return air plenum on a stand that is at least 14" from the floor. This will allow proper air return.

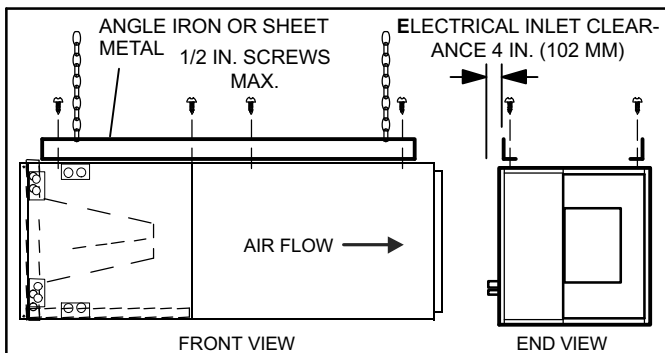

**Figure 3. Upflow Configuration**

**HORIZONTAL APPLICATIONS**

**⚠ IMPORTANT**

When removing the coil, there is possible danger of equipment damage and personal injury. Be careful when removing the coil assembly from a unit installed in right- or left-hand applications. The coil may tip into the drain pan once it is clear of the cabinet. Support the coil when removing it.



**Figure 4. Suspending Horizontal Unit**

*NOTE* — When the unit is installed in horizontal applications, a secondary drain pan is recommended. Refer to local codes.

*NOTE* — For applications where return air ducting is to be connected to the bottom of the coil blower, Lennox offers a duct adapter kit which mounts on the filter door side of the end of the unit (shown in figure 2). This provides a metal edge for attaching the return air duct. One duct adapter and two self-tapping screws are needed for each installation. Packages of 10 adapters/20 screws are available: 0658731-85 (Catalog No. X8103) for the -018/-024 size units; 0658731-86 (Catalog No. X8104) for the -030 to -060 size units.

*NOTE* — This unit may be installed in left-hand or right-hand air discharge horizontal applications. Adequate support must be provided to ensure cabinet integrity. Ensure that there is adequate room to remove service and access panels if installing in the horizontal position.

1. Determine whether left-hand or right-hand air discharge is required. If right-hand is required, perform *Right-Hand Discharge Modification* on page 6.
2. Determine knockouts required for drain line connections.
3. With access door removed, knock out drain line opening for installing drain lines.
4. Set unit so that it is sloped toward the drain pan end of the unit (see figure 10 on page 7).
5. The horizontal configuration is shown in figure 5.
6. If the unit is suspended, the entire length of the cabinet must be supported. If you use a chain or strap, use a piece of angle iron or sheet metal attached to the unit (either above or below) to support the length of the cabinet. Use securing screws no longer than 1/2 inch to avoid damaging the coil or filter. See figure 4. Use sheet metal screws to connect the return and supply air plenums as required.

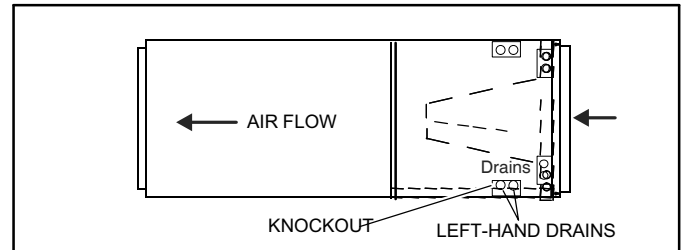

**Figure 5. Left-Hand Discharge Configuration  
RIGHT-HAND AIR DISCHARGE MODIFICATION**

For horizontal right-hand air discharge, the following field modifications are required.

1. Remove and set aside blower and coil access covers.
2. Remove the coil support bracket (detail A, figure 7).
3. Remove coil assembly, bottom drain pan and horizontal drain pan as one assembly from the air handler.
4. Remove two screws, blow off prevention bracket (where used; see table 2), and horizontal drip shield. Rotate the brackets 180° and reinstall using the same screws.
5. Move the horizontal drain pan to the opposite side of the coil. Be sure drain holes toward the back of the unit are plugged (see figure 8). Remove the plugs from the front drain pan ports.
6. Re-install modified coil/drain pan assembly in air handler in the same orientation as before.

7. Install the coil support bracket on the opposite side of the air handler (figure 7, detail B).

**Table 2. Blow Off Prevention Bracket**

Model	Front	Rear
-018	None	None
-024	None	None
-030	Yes	Yes
-036	Yes	Yes
-037	None	None
-042	None	None
-048*	Yes	None
-060	Yes	None

\* -048 model supported in TXV units only.

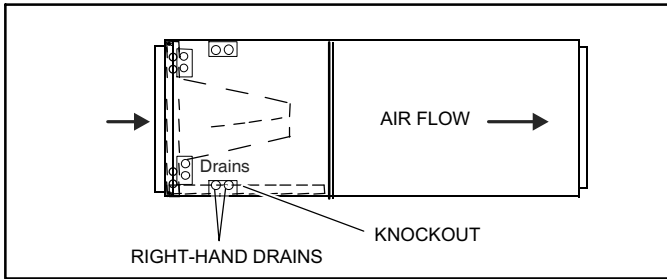

**Figure 6. Right-Hand Discharge Configuration**

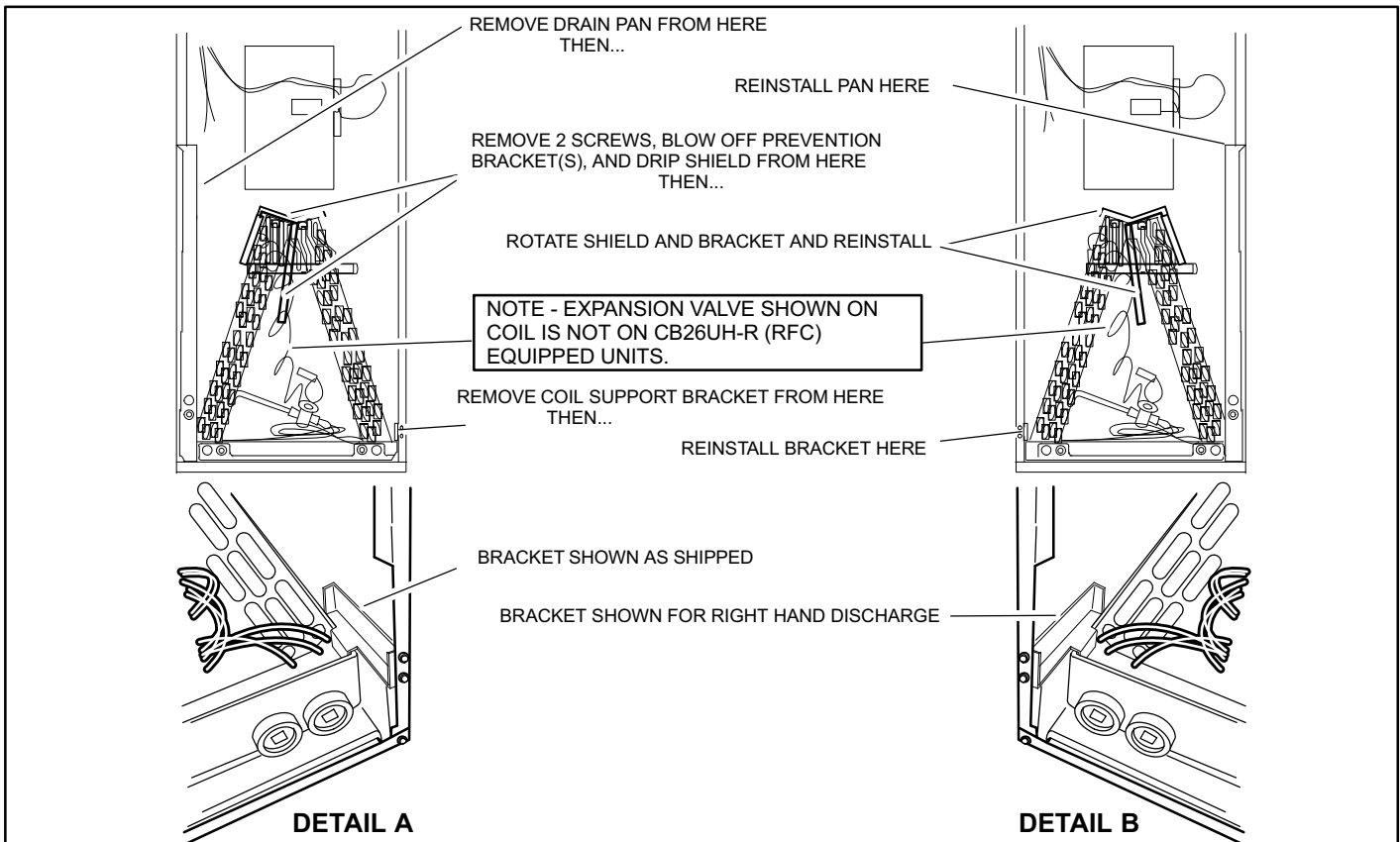

**Figure 7. Field Modification for Right-Hand Discharge**

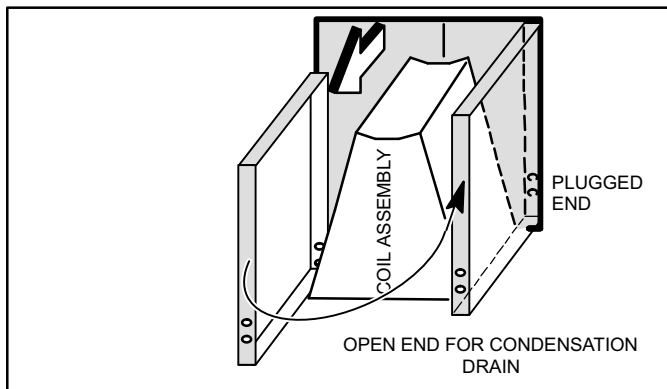

**Figure 8. Right-Hand Drain Plug Location**

**REFRIGERANT METERING DEVICE**

*NOTE — See the outdoor unit installation instructions and the Lennox Engineering Handbook for approved fixed orifice match-ups and application information.*

CB26UH-R units are equipped with a factory-installed refrigerant flow control (RFC) device (see table 1 on Page 3).

**⚠ IMPORTANT**

If a unit equipped with an RFC device is used in an application which requires conversion to an expansion valve, the fixed orifice must be removed before the expansion valve is installed.

The coil has a fixed orifice in the liquid line (see figure 9). Remove the rubber plug from the vapor line of the coil.

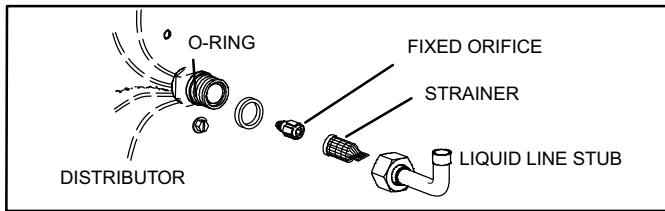

**Figure 9. Metering Device Installation**

## Condensate Drain

### ⚠ IMPORTANT

On units of this type, where the blower “draws” rather than “blows” air through the coil, traps must be installed in the condensate drain lines (primary and auxiliary, if used). Traps prevent the blower from drawing air through the drain lines into the air supply.

### ⚠ IMPORTANT

A field-fabricated secondary drain pan, with a drain pipe to the outside of the building, is required in all installations over a finished living space or in any area that may be damaged by overflow from the main drain pan. In some localities, local codes may require an secondary drain pan for any horizontal installation.

The air handler is provided with 3/4” NPT condensate drain connections.

### SLOPING THE DRAIN

Make sure the unit is sloped (similar to the slope shown in figure 10) so that the drain pan will empty completely without water standing in the pan.

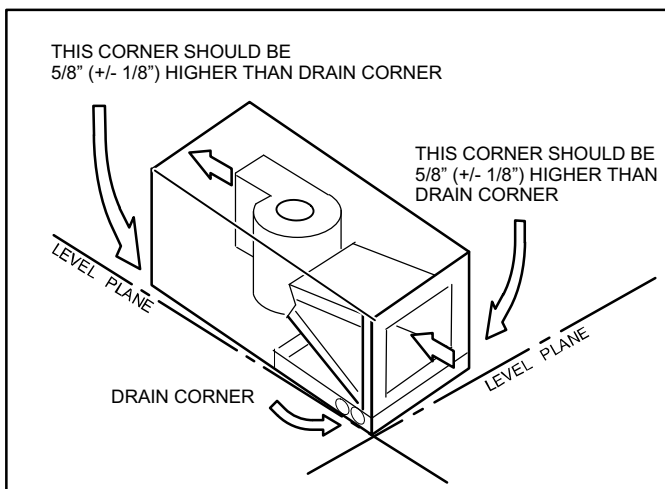

**Figure 10. Sloping the Drain**

## INSTALL CONDENSATE DRAIN

1. Remove the appropriate drain knockouts. If necessary, remove the indoor coil assembly from the cabinet.
2. Connect primary drain line connection to the primary drain pan connection. The primary drain connection is flush with the bottom of the inside of the pan. Secondary connection is raised above the bottom of the inside of the pan.

*NOTE — When making drain fitting connections to the drain pan, hand tighten the fitting and use a sealant. Over-tightening the fittings can split connections on the drain pan.*

3. If the auxiliary drain line is to be used, remove the plug and route the drain line so that water draining from the outlet will be easily noticed by the homeowner.
4. After removal of drain pan plugs, check the drain port to see if holes have been drilled. If not drilled, use a 19/32” bit to drill out the primary drain hole; use a 3/8” drill bit for the secondary drain hole. Remove all drill shavings.
5. Make sure drain ports and drain pan are free of all debris.
6. Plug and check any unused drain pan openings for tightness. Torque plugs to 30 in. lb. to prevent water leaks or seepage from the drain pan.
7. Install a 2” trap in the primary drain lines as close to the unit as practical (see figure 11). Make sure the top of the trap is below the connection to the drain pan to allow complete drainage of the pan.

*NOTE — Horizontal runs must have an anti-siphon air vent (standpipe) installed ahead of the horizontal run (See figure 11). An extremely long horizontal run may require an oversized drain line to eliminate air trapping.*

*NOTE — Do not operate air handler without a drain trap. The condensate drain is on the negative pressure side of the blower; therefore, air being pulled through the condensate line will prevent positive drainage without a proper trap.*

8. Route the drain line to the outside or to an appropriate drain. Drain lines must be installed so they do not block service access to the front of the air handler. A 24” clearance is required for filter, coil, or blower removal and service access.

*NOTE — Check local codes before connecting the drain line to an existing drainage system.*

Insulate the drain lines where sweating could cause water damage.

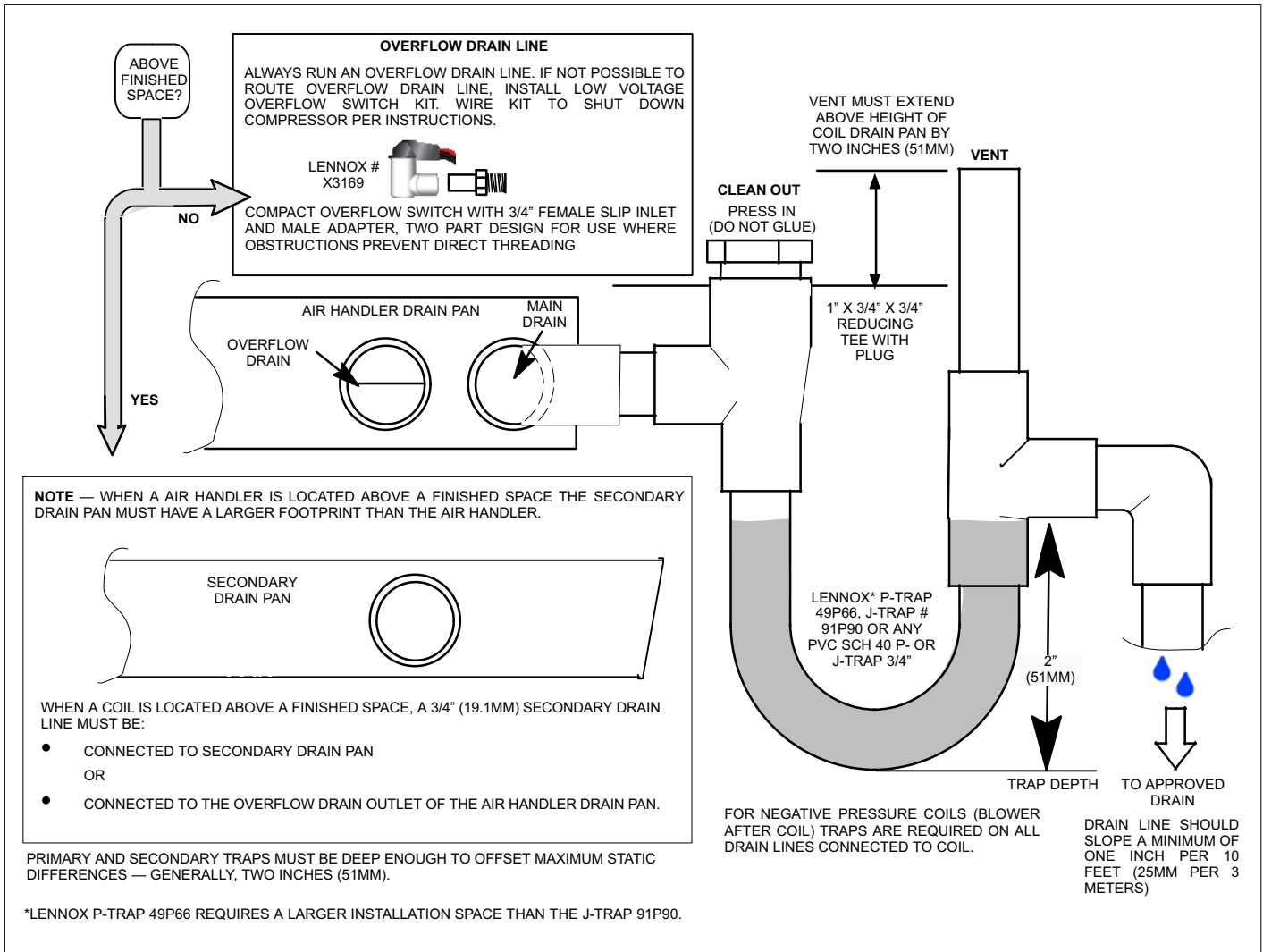

Figure 11. Typical Main and Overflow Drain

**TEST CONDENSATE DRAIN**

Test the drain pan and drain line after installation:

1. Pour several quarts of water into drain pan, enough to fill drain trap and line.
2. Check to make sure the drain pan is draining completely, no leaks are found in drain line fittings, and water is draining from the end of the primary drain line.
3. Correct any leaks found.

**Duct System and Filters**

**DUCT SYSTEM**

The air handler is provided with flanges for the connection of the plenum and ducts. The air handler is equipped with flanges that can form a filter rack for the installation of the air filter, or the filter may be installed as part of the return air duct system.

Supply and return duct system must be adequately sized to meet the system's air requirements and static pressure capabilities. The duct system should be insulated with a minimum of 1" thick insulation with a vapor barrier in conditioned areas or 2" minimum in unconditioned areas.

Table 3. Unit Air Filter Size Chart

Model	Filter Size
-018 / -024	15" x 20" (Effective 22 Mar 11)
-030 / -036	18" x 20"
-037 through -060	18" x 25"

Supply plenum should be the same size as the flanged opening provided around the blower outlet and should extend at least 3 ft. from the air handler before turning or branching off plenum into duct runs. The plenum forms an extension of the blower housing and minimizes air expansion losses from the blower.

**INSTALLING DUCT SYSTEM**

Install the conditioned air plenum, ducts and air filters (not provided) in accordance with NFPA 90B Standard for the Installation of Warm Air Heating and Air-Conditioning Systems (latest edition).

Connect supply air duct to the flange on top of the air handler. If an isolation connector is used, it must be nonflammable.



A return air duct system is recommended. If the unit is installed in a confined space or closet, a return connection must be run, full size, to a location outside the closet.

### Connecting Refrigerant Lines

Refrigerant lines must be connected by a qualified technician in accordance with established procedures.

### ! IMPORTANT

Refrigerant lines must be clean, dehydrated, refrigerant-grade copper lines. Air handler coils should be installed only with specified line sizes for approved system combinations.

Handle the refrigerant lines gently during the installation process. Sharp bends or possible kinking in the lines will cause a restriction.

Do not remove the caps from the lines or system connection points until connections are ready to be completed.

1. Route the suction and liquid lines from the fittings on the indoor coil to the fittings on the outdoor unit. Run the lines in as direct a path as possible avoiding unnecessary turns and bends.
2. Make sure that the suction line is insulated over the entire exposed length and that neither suction nor liquid lines are in direct contact with floors, walls, duct system, floor joists, or other piping.
3. Connect the suction and liquid lines to the evaporator coil.
4. To avoid damaging the rubber grommets in the cabinet while brazing, slide the rubber grommets over the refrigerant lines until they are away from the heat source.
5. Braze using an alloy of silver or copper and phosphorus with a melting point above 1,100°F.

*NOTE — Do not use soft solder.*

6. Reinstall the rubber grommets after brazing is finished.
7. Make sure outdoor unit has been put in place according to the Installation Instructions and is connected to the refrigerant lines.

### Sealing the Unit

Seal the unit so that warm air is not allowed into the cabinet. Warm air introduces moisture, which results in water blow-off problems. This is especially important when the unit is installed in an unconditioned area.

### ! WARNING

There must be an airtight seal between the bottom of the air handler and the return air plenum. Use fiberglass sealing strips, caulking, or equivalent sealing method between the plenum and the air handler cabinet to ensure a tight seal. Return air must not be drawn from a room where this air handler or any gas-fueled appliance (i.e., water heater), or carbon monoxide-producing device (i.e., wood fireplace) is installed.

### ! IMPORTANT

When sealing the cabinet, be sure to seal closed any space around the holes where the drain lines exit the cabinet using duct tape and/or Permagum. Warm air must not be allowed to enter through any gaps or holes in the cabinet.

Make sure the liquid line and suction line entry points are sealed with either Armaflex material or with Permagum. Permagum may also be used to seal around the main and auxiliary drains and around open areas of electrical inlets.

### Electrical Connections

### ! WARNING



Electric shock hazard! - Disconnect all power supplies before servicing.

Replace all parts and panels before operating.

Failure to do so can result in death or electrical shock.

### ! WARNING

Electric Shock Hazard.

Can cause injury or death.

Foil-faced insulation has conductive characteristics similar to metal. Be sure there are no electrical connections within a 1/2" of the insulation. If the foil-faced insulation comes in contact with electrical voltage, the foil could provide a path for current to pass through to the outer metal cabinet. While the current produced may not be enough to trip existing electrical safety devices (e.g. fuses or circuit breakers), the current can be enough to cause an electric shock hazard that could cause personal injury or death.

- All field wiring must be done in accordance with National Electrical Code, applicable requirements of UL and local codes, where applicable.
- Electrical wiring, disconnect means and over-current protection are to be supplied by the installer. Refer to the air handler rating plate for maximum over-current

protection, minimum circuit ampacity, as well as operating voltage.

- The power supply must be sized and protected according to the specifications supplied on the product.
- This air handler is factory-configured for 240 volt, single phase, 60 cycles. For 208-volt applications, see "208 Volt Conversion" later in this section.
- For optional field-installed electric heat applications, refer to the instructions provided with the accessory for proper installation.

**⚠ WARNING**  
**USE COPPER CONDUCTORS ONLY**

1. Disconnect all power supplies.
2. Remove the air handler access panel.
3. Route the field supply wires to the air handler electrical connection box.

**⚠ WARNING**

 Electrically ground air handler. Connect ground wire to ground terminal marked "GND". Failure to do so can result in death or electrical shock.

4. Use UL-listed wire nuts to connect the field supply conductors to the unit black and yellow leads, and the ground wire to ground terminal marked "GND."

5. Replace the air handler access panel.

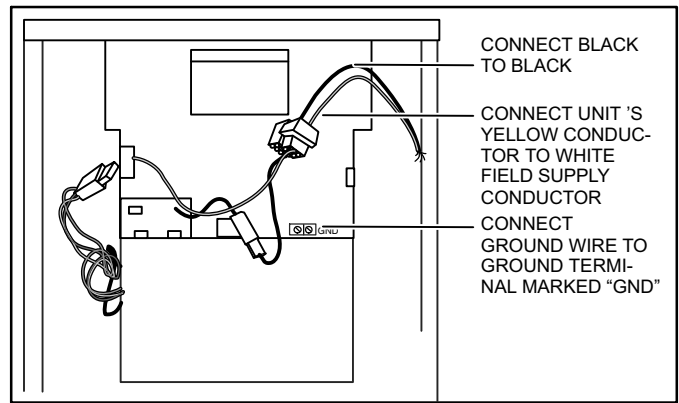

**Figure 12. Making Electrical Connections**  
**208 VOLT CONVERSION**

**⚠ WARNING**

 Electric shock hazard! - Disconnect all power supplies before servicing. Replace all parts and panels before operating. Failure to do so can result in death or electrical shock.

1. Disconnect all power supplies.
2. Remove the air handler access panel.
3. Using the wiring diagram in figure 13 as a reference, move the 2 connected black transformer leads from the 240 volt terminal on the transformer to the 208 volt terminal on the transformer.

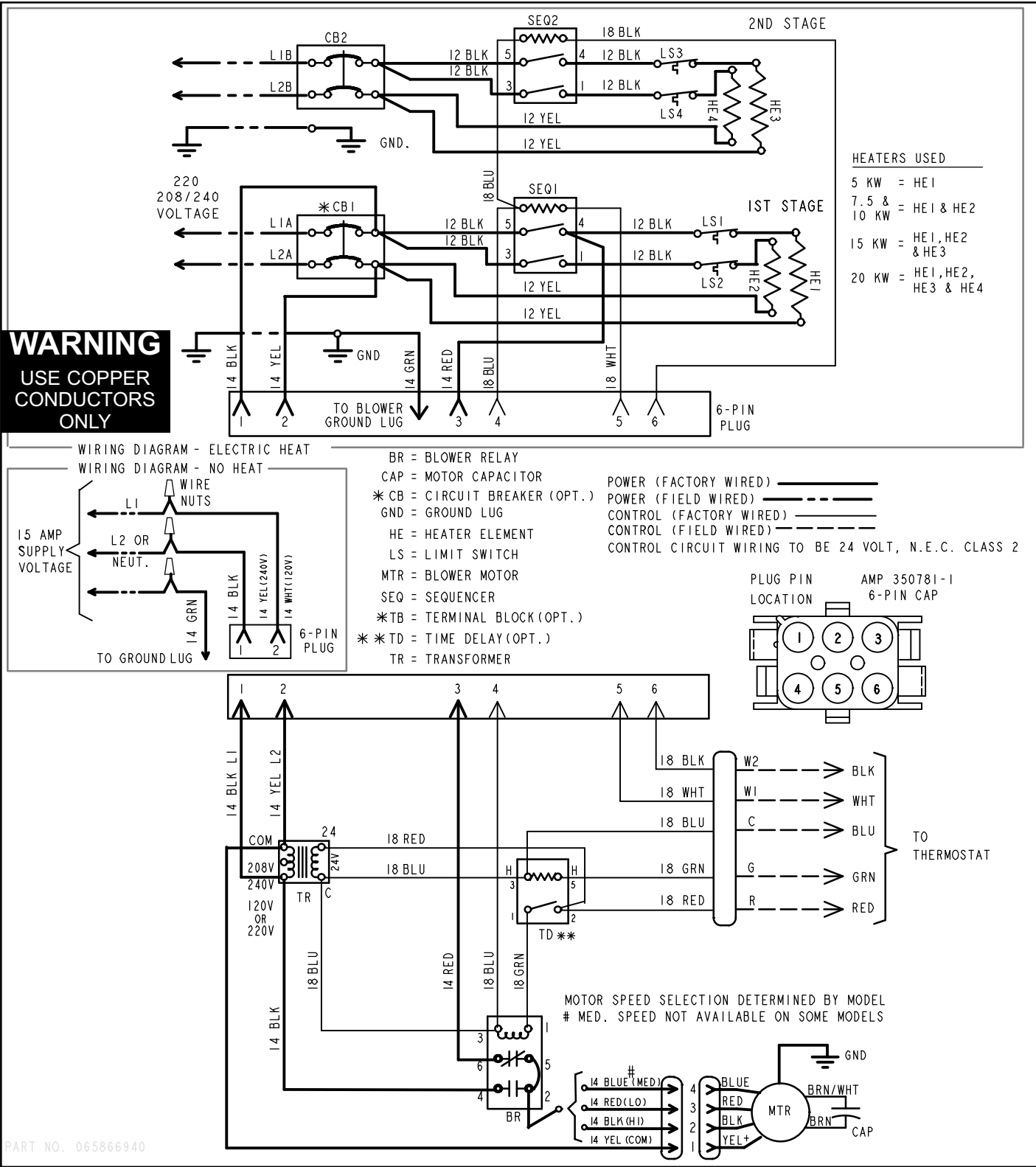
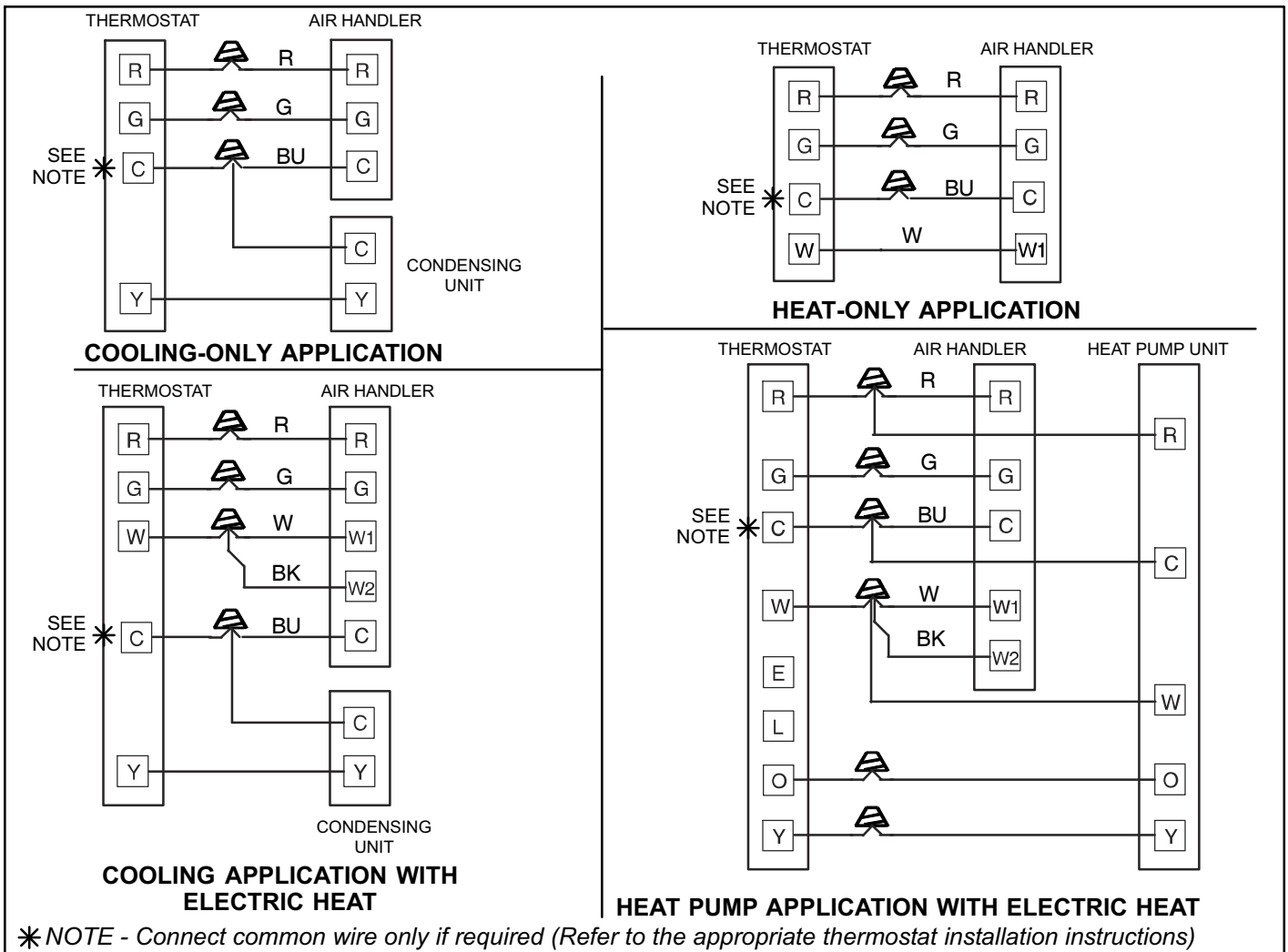

Figure 13. Wiring Diagram



### Airflow — Cooling Blower Speed

The cooling blower speed is factory configured to provide correct airflow for an outdoor unit that matches the maximum cooling capacity rating of the air handler.

If the outdoor unit is smaller than the maximum cooling capacity rating for the air handler, the cooling blower speed may need to be changed. Refer to Blower Performance Chart, table 4.

### CHANGE BLOWER SPEED

*NOTE* — Refer to wiring diagram (figure 13) and blower performance (table 4).

## ⚠ WARNING



Electric shock hazard! - Disconnect all power supplies before servicing.

Replace all parts and panels before operating.

Failure to do so can result in death or electrical shock.

1. Disconnect all power supplies.
  2. Remove the air handler access panel.
  3. Locate pin number 2 on the blower relay. Two black wires are connected to this terminal pin. One connects to pin number 5 on the blower relay, one connects to an in-line splice connecting to a red wire.
  4. Remove the wire going to the 4-pin blower motor connector from the splice.
  5. Connect the blower lead [Red (LO), Black (HI)] onto the splice from the 4-pin blower motor connector.
- NOTE* — Reuse the factory-installed plastic cap on whichever wire is not used.
6. Replace all panels.
  7. Reconnect power.

NOTES FOR TABLE 4 - All air data measured external to unit with 1 inch non-pleated air filter in place.

Electric heaters have no appreciable air resistance.

All factory settings are high-speed.

All data given while air handler is operating with a dry dx coil.

**Table 4. CB(X)26UH Blower Performance (2-Speed)**

Model	External Static Pressure		Air Volume at Specific Blower Taps			
			High (Black)		Low (Red)	
	in. w.g.	Pa	cfm	L/s	cfm	L/s
<b>-018 (LOW SPEED)</b>	.10	25	1020	460	755	340
	.20	50	960	435	715	325
	.30	75	885	400	675	305
	.40	100	800	365	625	285
	.50	125	690	315	570	260
	.60	150	525	250	500	235
<b>-024 (MEDIUM SPEED)</b>	.10	25	1040	470	1000	455
	.20	50	980	445	940	425
	.30	75	905	410	870	395
	.40	100	815	370	785	355
	.50	125	705	320	680	310
	.60	150	535	250	530	250
<b>-030 (MEDIUM SPEED)</b>	.10	25	1350	610	1145	520
	.20	50	1290	585	1090	495
	.30	75	1225	555	1030	465
	.40	100	1150	520	960	435
	.50	125	1065	485	875	395
	.60	150	965	455	775	365
<b>-036 (LOW SPEED)</b>	.10	25	1560	705	1405	635
	.20	50	1480	670	1340	610
	.30	75	1390	630	1270	575
	.40	100	1290	585	1185	540
	.50	125	1170	530	1090	495
	.60	150	1015	480	975	460
<b>-037 (LOW SPEED)</b>	.10	25	1570	740	1330	625
	.20	50	1520	715	1310	620
	.30	75	1440	680	1250	590
	.40	100	1300	615	1180	555
	.50	125	1170	550	1070	505
	.60	150	950	450	840	395
<b>-042 (MEDIUM SPEED)</b>	.10	25	1940	880	1785	810
	.20	50	1845	835	1705	775
	.30	75	1745	790	1615	730
	.40	100	1630	740	1515	685
	.50	125	1495	680	1400	635
	.60	150	1330	630	1265	595
<b>-048 (supported in TXV only) (MEDIUM SPEED)</b>	.10	25	1945	880	1870	850
	.20	50	1860	845	1790	810
	.30	75	1765	800	1700	770
	.40	100	1660	755	1600	725
	.50	125	1540	700	1485	675
	.60	150	1395	660	1350	635
<b>-060 (MEDIUM SPEED)</b>	.10	25	2160	980	2075	940
	.20	50	2065	935	1985	900
	.30	75	1960	890	1885	855
	.40	100	1845	835	1775	805
	.50	125	1710	775	1645	745
	.60	150	1550	730	1495	705

**Table 5. CB(X)26UH Blower Performance (3-Speed)**

Model	Ext. Static Pressure		Air Volume at Specific Blower Taps					
			Low (Red)		Med (Blue)		High (Black)	
	in. w.g.	Pa	cfm	L/s	cfm	L/s	cfm	L/s
<b>-018 (LOW SPEED)</b>	0.10	25	655	309	794	375	1074	507
	0.20	50	647	305	786	371	1000	472
	0.30	75	628	296	747	353	913	431
	0.40	100	578	273	672	317	809	382
	0.50	125	480	227	555	262	672	317
	0.60	150						
<b>-024 (MEDIUM SPEED)</b>	0.10	25	655	309	794	375	1074	507
	0.20	50	647	305	786	371	1000	472
	0.30	75	628	296	747	353	913	431
	0.40	100	578	273	672	317	809	382
	0.50	125	480	227	555	262	672	317
	0.60	150						
<b>-030 (MEDIUM SPEED)</b>	0.10	25	860	406	1020	481	1199	566
	0.20	50	851	402	1006	475	1195	564
	0.30	75	842	397	1003	473	1182	558
	0.40	100	813	384	963	454	1121	529
	0.50	125	721	340	886	418	1033	487
	0.60	150						
<b>-036 (LOW SPEED)</b>	0.10	25	1135	536	1354	639	1494	705
	0.20	50	1120	529	1345	635	1469	693
	0.30	75	1112	525	1317	621	1417	669
	0.40	100	1079	509	1260	595	1336	630
	0.50	125	995	470	1090	514	1250	590
	0.60	150						
<b>-042 (MEDIUM SPEED)</b>	0.10	25	1202	567	1404	663	1540	727
	0.20	50	1192	563	1413	667	1530	722
	0.30	75	1160	547	1386	654	1507	711
	0.40	100	1116	527	1303	615	1386	654
	0.50	125	998	471	1192	563	1254	592
	0.60	150						
<b>-048 (MEDIUM SPEED)</b>	0.10	25	1593	752	1759	830	1886	890
	0.20	50	1582	747	1709	806	1820	859
	0.30	75	1526	720	1636	772	1742	822
	0.40	100	1444	681	1538	726	1606	758
	0.50	125	1318	622	1395	658	1446	682
	0.60	150						
<b>-060 (MEDIUM SPEED)</b>	0.10	25	1782	841	2066	975	2109	995
	0.20	50	1755	828	1960	925	2067	975
	0.30	75	1672	789	1860	878	1949	920
	0.40	100	1554	733	1714	809	1770	835
	0.50	125	1393	657	1476	697	1586	748
	0.60	150						

## Check-out Procedures

### IMPORTANT

During installation, service or maintenance, make sure that copper tubing does not rub against metal edges or other copper tubing. Care should also be taken to ensure that tubing does not become kinked. Use wire ties to secure tubing to prevent movement.

Do not secure electrical wires to tubing that carries hot refrigerant gas. Heat from the tubing may melt the wiring insulation causing a short circuit.

*NOTE - Refer to outdoor unit installation instructions for system start-up instructions and refrigerant charging instructions.*

#### PRE-START-UP CHECKS

- Is the air handler properly and securely installed?
- If horizontally configured, is the unit sloped up to 1/4 inch toward drain lines?
- Will the unit be accessible for servicing?
- Has an auxiliary pan been provided under the unit with separate drain for units installed above a finished ceiling or in any installation where condensate overflow could cause damage?
- Have ALL unused drain pan ports been properly plugged?
- Has the condensate line been properly sized, run, trapped, pitched, and tested?
- Is the duct system correctly sized, run, sealed, and insulated?
- Have all cabinet openings and wiring been sealed?
- Is the indoor coil factory-installed TXV properly sized for the outdoor unit being used?
- Have all unused parts and packaging been disposed of?
- Is the filter clean, in place, and of adequate size?
- Is the wiring neat, correct, and in accordance with the wiring diagram?
- Is the unit properly grounded and protected (fused)?
- Is the thermostat correctly wired and in a good location?
- Are all access panels in place and secure?

#### CHECK BLOWER OPERATION

- Set thermostat to FAN ON.
- The indoor blower should come on.

#### CHECK COOLING OPERATION

- Set thermostat to force a call for cooling (approximately 5°F lower than the indoor ambient temperature).
- The outdoor unit should come on immediately and the indoor blower should start between **30 - 60** seconds later.
- Check the airflow from a register to confirm that the system is moving cooled air.

- Set the thermostat 5°F higher than the indoor temperature. The indoor blower and outdoor unit should cycle off.

#### CHECK ELECTRIC HEATER (IF USED)

- Set thermostat to call for auxiliary heat (approximately 5°F above ambient temperature). The indoor blower and auxiliary heat should come on together. Allow a minimum of 3 minutes for all sequencers to cycle on.
- Set the thermostat so that it does not call for heat. Allow up to 5 minutes for all sequencers to cycle off.

## Operation

#### COOLING (COOLING ONLY OR HEAT PUMP)

When the thermostat calls for cooling, 24 volts is put on the blower time-delay relay coil. After a delay, the indoor blower relay energizes. The normally open contacts close, causing the indoor blower motor to operate. The circuit between R and Y is completed, closing the circuit to the contactor in the outdoor unit, starting the compressor and outdoor fan motor.

On heat pumps, circuit R and O energizes the reversing valve, switching the valve to the cooling position. (The reversing valve remains energized as long as the thermostat selector switch is in the COOL position.)

At the completion of the cooling demand and after the relay's time-delay, the compressor and outdoor fan will cycle off.

#### HEATING (ELECTRIC HEAT ONLY)

When the thermostat calls for heat, the circuit between R and W is completed, and the heat sequencer is energized. A time delay follows before the heating elements and the indoor blower motor come on. Units with a second heat sequencer can be connected with the first sequencer to W on the thermostat subbase, or they may also be connected to a second stage on the subbase.

#### HEATING (HEAT PUMP)

When the thermostat calls for heating, 24 volts is put on the blower time-delay relay coil. After a delay, the normally open contacts close, causing the indoor blower motor to operate. The circuit between R and Y is completed, closing the circuit to the contactor in the outdoor unit, starting the compressor and outdoor fan motor. Circuit R and G energizes the blower relay, starting the indoor blower motor.

If the room temperature should continue to fall, the circuit between R and W1 is completed by the second-stage heat room thermostat. Circuit R-W1 energizes a heat sequencer. The completed circuit will energize supplemental electric heat (if applicable). Units with a second heat sequencer can be connected with the first sequencer to W1 on the thermostat. They may also be connected to a second heating stage W2 on the thermostat subbase.

#### TIME DELAY RELAY

On early production units, the indoor blower relay energizes after a **30** second delay and it remains energized for **30** seconds after the call is satisfied. The indoor blower will remain on for approximately 30 seconds before cycling off.

In January 2006, the blower relay was changed to 1 second delay **ON** and **45** second delay **OFF**.

### EMERGENCY HEAT (HEATING HEAT PUMP)

If the selector switch on the thermostat is set to the emergency heat position, the heat pump will be locked out of the heating circuit, and all heating will be electric heat (if applicable). A jumper should be placed between W2 and E on the thermostat subbase so that the electric heat control will transfer to the first-stage heat on the thermostat. This will allow the indoor blower to cycle on and off with the electric heat when the fan switch is in the AUTO position.

### Accessories

Contact your Lennox dealer for the following accessories:

- Electric Heat Kit—See the accessory kit label on the front panel of the air handler for the electric heat kit options and accessories.

### Maintenance

## ⚠ IMPORTANT

Do not operate system without a filter. A filter is required to protect the coil, blower, and internal parts from excessive dirt and dust. The filter is placed in the return duct by the installer.

- Inspect air filters at least once a month and replace or clean as required. Dirty filters are the most common cause of inadequate heating or cooling performance.
- Replace disposable filters. Cleanable filters can be cleaned by soaking in mild detergent and rinsing with cold water.
- Install new/clean filters with the arrows on the side pointing in the direction of airflow. Do not replace a cleanable (high velocity) filter with a disposable (low velocity) filter unless return air system is properly sized for it.
- If water should start coming from the secondary drain line, a problem exists which should be investigated and corrected. Contact a qualified service technician.

### Cabinet Insulation

## ⚠ IMPORTANT

**DAMAGED INSULATION MUST BE REPAIRED OR REPLACED** before the unit is put back into operation. Insulation loses its insulating value when wet, damaged, separated or torn.

Matt- or foil-faced insulation is installed in indoor equipment to provide a barrier between outside air conditions (surrounding ambient temperature and humidity) and the varying conditions inside the unit. If the insulation barrier is damaged (wet, ripped, torn or separated from the cabinet walls), the surrounding ambient air will affect the inside surface temperature of the cabinet. The temperature/humidity difference between the inside and outside of the cabinet can cause condensation on the inside or outside of the cabinet which leads to sheet metal corrosion and subsequently, component failure.

### REPAIRING DAMAGED INSULATION

Areas of condensation on the cabinet surface are an indication that the insulation is in need of repair.

If the insulation in need of repair is otherwise in good condition, the insulation should be cut in an X pattern, peeled open, glued with an appropriate all-purpose glue and placed back against the cabinet surface, being careful to not overly compress the insulation so the insulation can retain its original thickness. If such repair is not possible, replace the insulation. If using foil-faced insulation, any cut, tear, or separations in the insulation surface must be taped with a similar foil-faced tape.

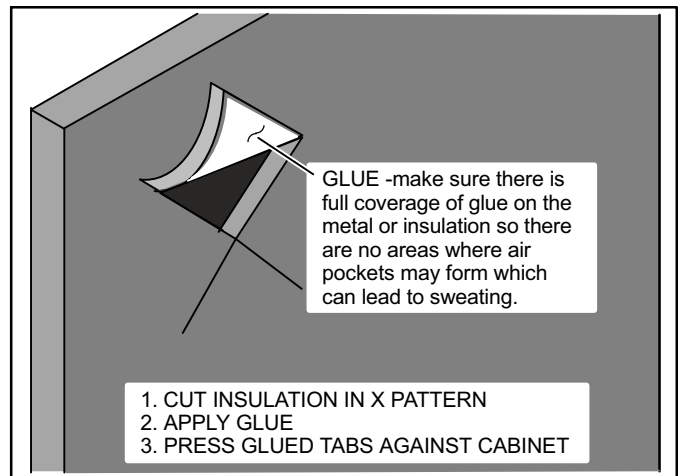

Figure 15. Repairing Insulation