

ZCD

RAIDER® ROOFTOP UNITS

Standard Efficiency | Environ™ Coil | **R-454B** | 60Hz



**COMMERCIAL
PRODUCT SPECIFICATIONS (EHB)**

3 to 6 Tons

Net Cooling Capacity – 35,000 to 67,000 Btuh

Optional Electric Heat - 5 to 30 kW

RAIDER

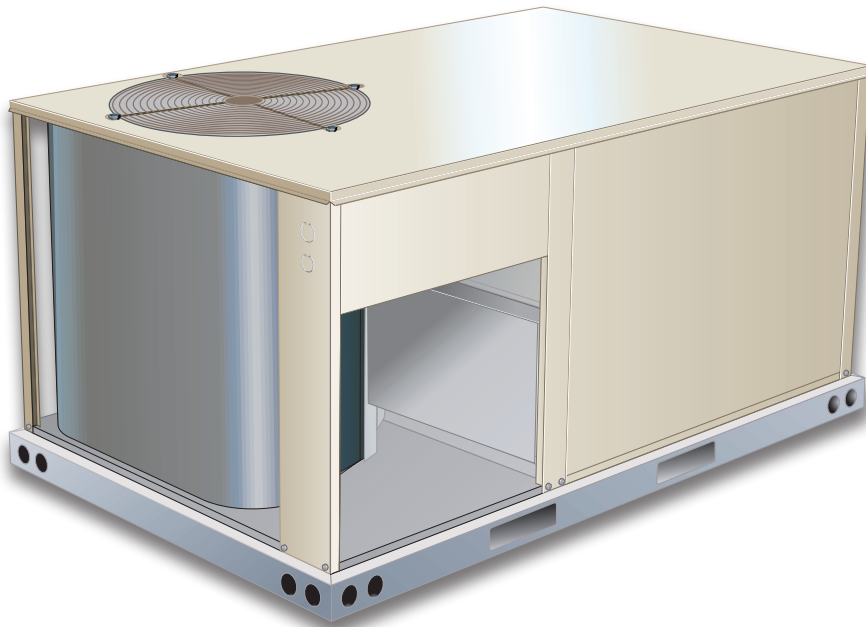

ASHRAE
Standard
90.1

MODEL NUMBER IDENTIFICATION

Z C D 060 S 5 B N 1 Y

Brand/Family
Z = Raider®

Unit Type
C = Packaged Electric Cooling w/ optional Electric Heat

Major Design Sequence
D = 4th Generation

Nominal Cooling Capacity - Tons
036 = 3 Tons
048 = 4 Tons
060 = 5 Tons
074 = 6 Tons

Cooling Efficiency
S = Standard Efficiency

Refrigerant Type
5 = R-454B

Voltage
P = 208/230V-1 phase-60Hz
Y = 208/230V-3 phase-60Hz
G = 460V-3 phase-60Hz
J = 575V-3 phase-60Hz

Minor Design Sequence
1 = 1st Revision

Factory Installed Electric Heat
N = No Heat

Blower Type
B = Belt Drive
T = Belt Drive (Two-Speed)

FEATURE HIGHLIGHTS

Raider® rooftop units from Lennox Commercial are the new standard for cost efficient reliable, efficient rooftop units built for long-lasting performance that can significantly improve indoor environments.

1. Scroll Compressor
2. Environ™ Coil System
3. Outdoor Coil Fan Motor
4. Heavy Gauge Steel Cabinet
5. Smoke Detector (option)
(Supply and Return)
6. Supply Air Blower
7. Disconnect Switch (option)
8. Electric Heat (option)
9. GFI Service Outlet (option)

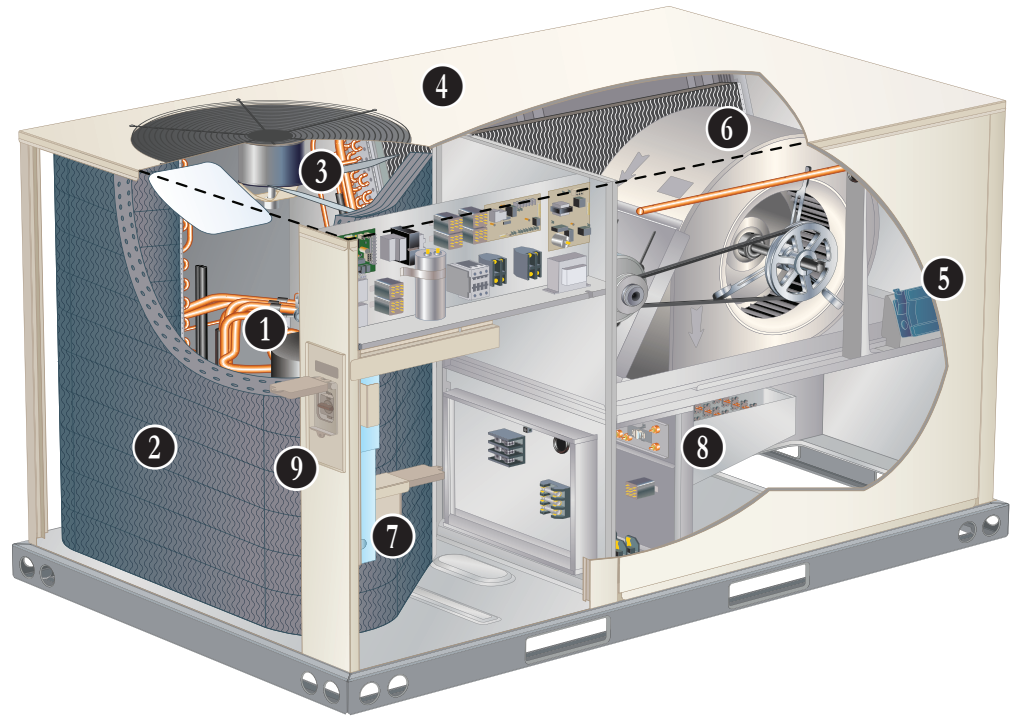

CONTENTS

Approvals And Warranty	3
Blower Data	16
Dimensions - Accessories	33
Dimensions - Unit	32
Electrical Accessories	27
- Disconnects	27
- Fuse Blocks	28
Electrical/Electric Heat Data	23
Electric Heat Capacities	29
Features And Benefits	3
Model Number Identification	1
Optional Conventional Temperature Control Systems	9
Options / Accessories	10
Outdoor Sound Data	29
Ratings	14
Specifications	13
Unit Clearances	30
Weight Data	31

APPROVALS AND WARRANTY

APPROVALS

- All 2-5 ton models are AHRI Standard 210/240-2024 certified
- All 6 ton models are AHRI Standard 340/360-2022 certified
- ETL and CSA listed
- All models are ASHRAE 90.1-2025 compliant
- All models meet DOE 2023 energy efficiency standards
- All models are listed to UL 60335-1 and UL 60335-2-40 and meet the Refrigerant Detection and Dissipation Requirements
- Components are bonded for grounding to meet safety standards for servicing required by ETL, NEC and CEC
- All 6 ton models meet California Code of Regulations, Title 24 and ASHRAE 90.1-2025 Section 6.4.3.10 requirements for staged airflow
- All models have been sound tested in accordance with test conditions included in AHRI Standard 270 or 370
- All models have FSA approval and are compliant with standard ASCE 7-22 (ASD) and the Florida Building Code Eighth Edition (2023)
- Units are charged with virgin refrigerant to comply with NYCRR Part 494
- All models are fully charged and run tested to verify unit operation and functionality

WARRANTY

- Compressors - Limited five years
- Environ™ Coil System - Limited three years
- High Performance Economizers (optional) - Limited five years
- All other covered components - Limited one year

FEATURES AND BENEFITS

COOLING SYSTEM

- Designed to maximize sensible and latent cooling performance at design conditions
- System can operate from 35°F to 125°F without any additional controls

R-454B Refrigerant

- Low GWP (Global Warming Potential)
- Zero ODP (Ozone Depletion Potential)
- Low Toxicity/Lower Flammability - A2L
- Unit is factory pre-charged

1 Single-Stage Scroll Compressor (036 through 060 Models)

- Resiliently mounted on rubber grommets for quiet operation
- Scroll compressor for high performance, reliability and quiet operation

Two-Stage Compressor (074 Models)

- Two-stage scroll compressors for increased part load efficiency, high performance, reliability and quiet operation
- Resiliently mounted on rubber grommets for quiet operation

Compressor Crankcase Heater

- Protects against refrigerant migration that can occur during low ambient operation or during extended off cycles

Refrigerant Metering Orifice (036 to 060 Models)

- Accurately meters refrigerant in system
- Refrigerant control is accomplished by exact sizing of refrigerant metering orifice

Thermal Expansion Valve (074 Models)

- Ensures optimal performance throughout the application range.
- Removable element head

Filter/Drier

- High capacity filter/drier protects the system from dirt and moisture

High Pressure Switch

- Protects the compressor from overload conditions such as dirty condenser coils, blocked refrigerant flow or loss of outdoor fan operation

Low Pressure Switch

- Protects the compressor from low pressure conditions such as low refrigerant charge or low/no airflow.

2 Environ™ Coil System

- Condenser and evaporator coil
- Lightweight, all aluminum brazed fin construction
- Constructed of three components:
 - A flat extrusion tube
 - Fins in-between the flat extrusion tube
 - Two refrigerant manifolds

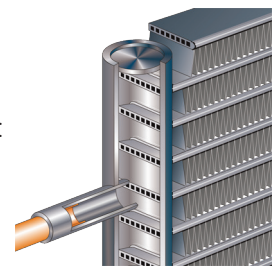

FEATURES AND BENEFITS

COOLING SYSTEM (continued)

Environ™ Coil System Features:

- Improved heat transfer performance due to high primary surface area (flat tubes) versus secondary surface (fins)
- Smaller internal volume (reduced refrigerant charge)
- High durability
- All aluminum construction
- Fewer brazed joints
- Compact design
- Reduced unit weight
- Easy maintenance/cleaning
- Mounting brackets with rubber inserts secure coil to unit providing vibration dampening and corrosion protection

Antimicrobial Condensate Drain Pan

- Composite pan, sloped to meet drainage requirements of ASHRAE 62.1
- Antimicrobial additive resists growth of mold and mildew on drain pan, which improves indoor air quality and reduces drain line blockage
- End drain connection

3 Outdoor Coil Fan Motor

- Thermal overload protected
- Totally enclosed
- Permanently lubricated bearings
- Shaft down
- Fan guard mount

Outdoor Coil Fan Guard

- PVC coated fan guard furnished

Required Selections

Cooling Capacity

- Specify nominal cooling capacity

Options/Accessories

Field Installed

Condensate Drain Trap

- Available in copper or PVC

Drain Pan Overflow Switch

- Monitors condensate level in drain pan
- Shuts down unit if drain becomes clogged

Low Ambient Kit (0°F)

- Cycles the outdoor fans while allowing compressor operation in the cooling cycle
- Intermittent fan operation allows the system to operate without icing the evaporator coil and losing capacity
- Designed for use in ambient temperatures no lower than 0°F

LOW GWP REFRIGERANT DETECTION SYSTEM (RDS)

- Complies with UL 60335-2-40 approved standard
- Required for all systems using R-454B refrigerant
- Factory installed on all units
- Consists of a refrigerant detection sensor(s) and a mitigation control
- Ensures safe operation for systems equipped with R-454B refrigerant
- Sensor(s) monitors indoor coil area for R-454B refrigerant
- If R-454B refrigerant is detected the refrigerant detection system will prevent compressor and heating operation until R-454B refrigerant is no longer detected
- Refrigeration detection system energizes blower if any R-454B refrigerant is detected to mitigate any concentrations of refrigerant from the unit and the system

CABINET

Construction

- 4** • Heavy-gauge steel panels
- Full perimeter heavy-gauge galvanized steel base rail
- Base rails have rigging holes
- Three sides of the base rail have forklift slots
- Raised edges around duct and power entry openings in the bottom of the unit for water protection

Airflow Choice

- Units are shipped in downflow (vertical) return air flow configuration

NOTE - Units can be field converted to horizontal airflow.

Power Entry

- Electrical lines can be routed through the unit base or through horizontal access knock-outs

NOTE - Optional Bottom Power Entry Kit is available.

Exterior Panels

- Constructed of heavy-gauge, galvanized steel
- Textured pre-paint with polyurethane finish
- Cyclic salt fog and UV exposure up to 1,680 hours per ASTM D5894

Insulation

- Fully insulated with non-hygroscopic fiberglass insulation (conditioned areas)

Access Panels

- Compressor
- Heating
- Controls
- Blower
- Air filter/economizer section

FEATURES AND BENEFITS

CABINET (Continued)

Options/Accessories

Field Installed

Combination Coil/Hail Guards

- Heavy gauge steel frame
- Painted to match cabinet
- Expanded metal mesh protects outdoor coil

CONTROLS

Compressor Monitor Control

- Anti-short cycle control (5 minutes)
- High and low pressure switch monitoring with five-strike lockout protection
- LEDs for diagnostic and troubleshooting

Refrigerant Detection System (RDS) Control

- Monitors leak detection sensor
- Terminal strip for thermostat, float switch and RDS alarm connections
- LED for power and sensor status

24V Transformer

- For all control voltage
- Resettable pop-up fuse

Options/Accessories

Field Installed

5 Smoke Detector

- Photoelectric type
- Installed in supply air section, return air section or both sections
- Available with power board and single sensor (supply or return) or power board and two sensors (supply and return)
- Power board located in unit blower compartment

Thermostats

- Control system and thermostat options, see page 9

BLOWER

A wide selection of supply air blower options are available to meet a variety of air flow requirements

Motor

- Overload protected
- Ball bearings
- Belt drive motors are offered on all models and are available in several different sizes to maximize air performance
- Two-speed belt drive motor (low static/high static) is available on 074 models

6 Supply Air Blower

- Forward curved blades
- Blower wheel statically and dynamically balanced.
- Ball bearings
- Adjustable pulley (allows speed change)

MSAV® Multi-Stage Air Volume Operation (2-Speed Blower Units)

- MSAV® Multi-Stage Air Volume stages the amount of airflow according to compressor stages, heating demand and ventilation demand
- Units utilize a 2-Speed induction blower motor to stage the supply air blower airflow
 - Low Speed - 1st Stage cooling, and ventilation mode
 - High Speed - 2nd Stage (Full load) cooling and all heat modes
- High speed blower operation is set by adjusting the motor pulley to deliver the desired air volume

NOTE: Ventilation speed is same as low speed for improved energy savings. Lower operating costs are obtained when the blower is operated on lower speeds.

NOTE: Part-load airflow in cooling mode should not be set below 220 cfm/nominal full load ton to reduce the risk of evaporator coil freeze-up.

MSAV® Multi-Stage Air Volume Sequence of Operation (2-Speed Blower Units)

- Blower operates in low speed with (G) demand
- Blower operates in low speed for mechanical cooling (Y1)
- Blower operates in high-speed for any other mode: (Y1+Y2), and heating
- Economizer damper minimum position is fully closed in unoccupied mode
- In occupied mode, the economizer damper minimum position is determined by the economizer minimum position of the potentiometer
- When Outdoor air is not suitable the blower operates on low speed for (Y1) and switches to high-speed for (Y1+Y2)
- In free cooling, the blower operates on low speed for (Y1)

NOTE: Economizer position is determined by mixed air sensor when unit is in free cooling.

Required Selections

Supply Air Blower

- Order blower motor horsepower and drive kit number required when base unit is ordered
- See Drive Kit Specifications Table

FEATURES AND BENEFITS

ELECTRICAL

Marked & Color-Coded Wiring

- All electrical wiring is color-coded and marked to identify which components it is connecting

Electrical Plugs

- Positive connection electrical plugs are used to connect common accessories or maintenance parts for easy removal or installation

Required Selections

Voltage Choice

- Specify when ordering base unit

Options/Accessories

Factory or Field Installed

7 Disconnect Switch

- Accessible from outside of unit
- Spring loaded weatherproof cover furnished

Field Installed

Bottom Power Entry Kit

- Kit reduces the number of penetrations in the roof
- Kit includes bulkhead connectors to provides power and control wiring routing through the roof curb

8 Electric Heat

- Helix wound nichrome elements
- Individual element limit controls
- Wiring harness

NOTE - See Options / Accessories tables for ordering information.

NOTE - Unit Fuse Block is required and must be ordered separately. See Electrical / Electric Heat tables for ordering information.

9 GFI Service Outlets (2)

- 115V ground fault circuit interrupter (GFCI) type
- Field installed, non-powered, field-wired
- Waterproof heavy-duty UV resistant polycarbonate case cover furnished

INDOOR AIR QUALITY

Air Filters

- Disposable 2 inch MERV 4 filters furnished as standard

Options/Accessories

Field Installed

Indoor Air Quality (CO₂) Sensor

- Monitors CO₂ levels adjusts economizer dampers as needed for Demand Control Ventilation

OPTIONS / ACCESSORIES

ECONOMIZER

Economizer (Downflow or Horizontal) (Standard and High Performance Common Features)

- Outdoor Air Hood is furnished
- Includes Barometric Relief Dampers with Exhaust Hood
- Barometric Relief Dampers allow relief of excess air,
- Aluminum blade dampers prevent blow back and outdoor air infiltration during off cycle
- Exhaust hood with bird screen furnished
- Demand Control Ventilation (DCV) ready using optional CO₂ sensors
- Single temperature control is furnished with Economizer
- Outdoor air sensor enables Economizer if the outdoor temperature is less than the setpoint of the control

NOTE - Horizontal Economizer is field installed only.

Field Installed

Standard Economizer Features (Not for Title 24)

- Gear-driven action
- Return air and outdoor air dampers
- Plug-in connections to unit
- Nylon bearings
- Neoprene seals
- 24-volt
- Fully-modulating spring return motor

Standard Economizer Control Module

The Standard Economizer Control Module can be adjusted to operate based on outdoor air temperatures

Economizer Controls:

- **Damper Minimum Position** - Can be set lower than traditional minimum air requirements resulting in cost savings
- **IAQ Sensor** - Signals dampers to modulate and maintain 55°F when CO₂ is higher than the CO₂ setpoint
- **Demand Control Ventilation (DCV) LED** - A steady green Demand Control Ventilation LED indicates the IAQ reading is higher than setpoint and requires more fresh air
- **Free Cool LED** - A steady green LED indicates outdoor air is suitable for free cooling

NOTE - Free Cooling runs when outdoor air temperature is lower than the set temperature on the economizer control.

NOTE: The Free Cooling default setting for outdoor air temperature sensor is 55°F.



OPTIONS / ACCESSORIES

ECONOMIZER (continued)

Factory or Field Installed

High Performance Economizer Control Module

- Provides inputs and outputs to control economizer based on parameter settings
- Free cooling based on single dry bulb temperature, or combination temperature + humidity sensors
- Automatic switchover for different control modes
- Parameter settings based on climate zone, using GPS functionality in the Climatix Mobile application
- LED indication for free cooling operation, sensor operation and damper operation
- Quick installation and easy commissioning with the Climatix Mobile App on a mobile device

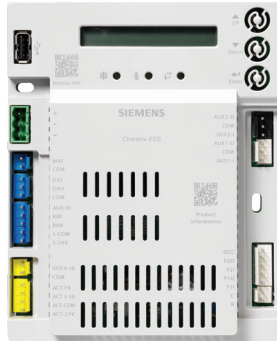

NOTE - WLAN Stick is required for App connection to module(s).

- Module displays any alarm messages (fault detection and diagnostics) as an aid in troubleshooting
- RS585 port for BACnet MSTP or Modbus RTU communication
- USB port for firmware updates and WLAN connection for setup and commissioning
- QR codes on module for quick access to download Climatix Mobile App and user documentation
- User Interface for normal operation, parameter setup and, alarm notifications with an LCD display and three operation buttons:
 1. **Up Button** - Move to the previous value, step or category
 2. **Down Button** - Move to the next value, step or category
 3. **Enter Button** -
 - Press to edit the current value or option
 - Press to confirm a newly selected value or option
 - Press Enter + Up to jump up one category
 - Press Enter + Down to jump down one category

NOTE - The Free Cooling setpoint for Title 24 applications must be set based on the Climate Zone where the system is installed. See Section 140.4 "Prescriptive Requirements for Space Conditioning Systems" of the California Energy Commission's 2013 Building Energy Efficiency Standards.

NOTE - Refer to Installation Instructions for complete setup information and menu parameters available.

Field Installed

Single Enthalpy Temperature Control

- Outdoor air enthalpy sensor enables economizer if the outdoor enthalpy is less than the setpoint of the control

Differential Enthalpy Control (Not for Title 24)

- Order one for factory installed economizer
- Order two for field installed economizer
 - One is field installed in the return air section
 - One in the outdoor air section
- Allows the economizer control board to select between outdoor air or return air, whichever has lower enthalpy

WLAN Stick

- Required for Climatix Mobile App usage
- Plugs into USB port on Module to provide a temporary WLAN connection for setup, commissioning, and servicing

NOTE - Only one WLAN Stick is required and can be used on multiple modules.

OPTIONS / ACCESSORIES

EXHAUST

Field Installed

Power Exhaust Fan - Downflow or Horizontal

- Installs external to unit for applications with Economizer option
- Provides exhaust air pressure relief
- Interlocked to run when supply air blower is operating
- Fan runs when outdoor air dampers are 50% open (adjustable)
- Motor is overload protected
- Fan is 12 in. diameter
- Five fan blades
- 1/2 HP motor.

NOTE - Not available for 460V.

OUTDOOR AIR

Field Installed

Outdoor Air Dampers - Downflow

- Single blade damper
- 0 to 25% (fixed) outdoor air adjustable
- Installs in unit
- Motorized model features fully modulating spring return damper motor with plug-in connection
- Manual model features a slide damper

NOTE - Maximum mixed air temperature in cooling mode is 100°F.

ROOF CURBS

Field Installed

Hybrid Roof Curbs, Downflow

- Nail strip furnished; mates to unit
- US National Roofing Contractors approved
- Shipped knocked down
- Interlocking tabs fasten corners together
- No tools required for assembly
- Can also be fastened together with furnished hardware
- Available in 8, 14, 18, and 24 inch heights

Adaptor Curbs (not shown)

- Curbs are regionally sourced
- Dimensions will vary based upon the source

NOTE - Contact your local sales representative for a detailed cut sheet with applicable dimensions

CEILING DIFFUSERS

Field Installed

- Flush or Step-Down
- White powder coat finish on diffuser face and grilles
- Insulated UL listed duct liner
- Diffuser box has collars for duct connection
- Step-down diffusers have double deflection blades
- Flush diffusers have fixed blades
- Provisions for suspending
- Internally sealed to prevent recirculation
- Removable return air grille
- Adapts to T-bar ceiling grids or plaster ceilings

Transitions (Supply and Return)

NOTE - Ceiling Diffuser Transitions are not furnished and must be field fabricated.

OPTIONAL CONVENTIONAL TEMPERATURE CONTROL SYSTEMS

CS7500 Commercial 7-Day Programmable Thermostat



- Premium Universal Thermostat
- Full Color Touchscreen Interface
- Up To 4 Heat / 3 Cool
- Built-In Sensors For Temperature and Humidity
- Remote Sensors Options For Temperature, Discharge Air, Outdoor Air
- 5-2 or 7-Day Scheduling
- Smooth Setback Recovery
- Heat/Cool Auto-Changeover
- FDD, ASHRAE, IECC Compliant

CS3000 Commercial 5-2 Day Programmable Thermostat

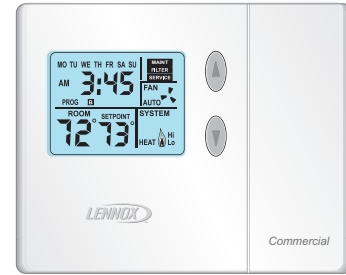

- Conventional Multi-Stage Thermostat
- Intuitive Display
- Push-Button Operation
- Up To 2 Heat / 2 Cool
- Built-In Temperature Sensor
- Remote Temperature Sensing
- Up to 5-2 Day Scheduling
- Smooth Setback Recovery
- Heat/Cool Auto-changeover

BACnet Compatible Thermostat With Reheat



Description	Order Number
CS7500 Commercial 7-Day Programmable Thermostat	
CS7500 7-Day Thermostat	24K41
Sensors/	¹ Remote non-adjustable wall-mount 20k 47W36
Accessories	¹ Remote non-adjustable wall-mount 10k 47W37
	Remote non-adjustable discharge air (duct mount) 19L22
	Outdoor temperature sensor X2658
CS3000 5-2 Day Programmable Thermostat	
CS3000 5-2 Day Thermostat	11Y05
Sensor/	Remote non-adjustable wall mount 10k averaging 47W37
Accessories	Thermostat wall mounting plate X2659
BACnet 7-Day Programmable Thermostat	
BACnet	² 7-Day BACnet Thermostat 24C57
Controls	³ BACnet Module 16X70
⁴ BACnet	With Display 97W23
Room Sensors	Without Display 97W24
Universal Thermostat Guard with Lock (clear)	
Inside Dimensions (H x W x D)	5-7/8 x 8-3/8 x 3 in. 39P21

¹ 1 Remote wall-mount sensors can be applied in any of the following combinations:
 One Sensor - (1) 47W36, Two Sensors - (2) 47W37, Three Sensors - (2) 47W36 and (1) 47W37
 Four Sensors - (4) 47W36, Five Sensors - (3) 47W36 and (2) 47W37

² 2 BACnet Thermostat (24C57) will control units with and without the Humiditrol® option. If there is a mix of units equipped with and without Humiditrol on the same site, this thermostat can be used for all units if suitable.

³ 3 Not compatible with units equipped with Humiditrol® option.

⁴ 4 Only compatible with BACnet Module (16X70).

- 7-Day Programmable
- For units with or without Humiditrol®
- BTL listed MS/TP ensures compatibility with any BACnet system
- Built-in control programs for conventional and heat pump applications
- Conventional systems up to 3-stage heat and 3-stage cool
- Heat pumps with 1 or 2 compressors and up to 2-stage auxiliary heat
- On-board temperature and humidity sensor
- Multiple configurable inputs and outputs enable advanced control strategies
- Set-up Wizard enables rapid system configuration
- No special tools required for installation or commissioning
- Seven-day (2, 4 or 6 event) occupancy scheduling per day
- Backlit 5-inch LCD touchscreen

OPTIONS / ACCESSORIES

Item	Order Number	Size				
		036	048	060	074	
COOLING SYSTEM						
Condensate Drain Trap	PVC	38R23	X	X	X	X
	Copper	38V21	X	X	X	X
Drain Pan Overflow Switch		38A64	X	X	X	X
Low Ambient Kit		99W67	X	X	X	X
BLOWER - SUPPLY AIR						
Motors	Belt Drive - .75 HP (203/230V-1ph)	Factory	O			
	Belt Drive - 1 HP (208/230V, 460V, 575V-3ph)	Factory	O	O		
	Belt Drive - 1.5 HP (208/230V-1ph)	Factory		O	O	
	Belt Drive - 1.5 HP (208/230V, 460V, 575V-3ph)	Factory			O	
	Belt Drive - 2 HP (208/230V, 460V, 575V-3ph) (2 Speed)	Factory				O
Drive Kits See Blower Data Tables for selection	Kit #ZA01 - 678-1035 rpm	Factory	O			
	Kit #ZA02 - 803-1226 rpm	Factory		O		
	Kit #ZA03 - 906-1383 rpm	Factory			O	
	Kit #ZA04 - 964-1471 rpm	Factory	O			
	Kit #ZA05 - 1098-1490 rpm	Factory			O	
	Kit #ZAA02 - 632-875 rpm	Factory				O
	Kit #ZAA03 - 798-1105 rpm	Factory				O
	Kit #ZAA04 - 921-1226 rpm	Factory				O
CABINET						
Coil/Hail Guards		12X19	X	X		
		12X20			X	X
CONTROLS						
Smoke Detector - Supply or Return (Power board and one sensor)		39U76	X	X	X	X
Smoke Detector - Supply and Return (Power board and two sensors)		39U75	X	X	X	X
NOTE - See Conventional Thermostat Control Systems on page XX for Additional Options.						
ELECTRICAL						
Voltage 60 Hz	208/230V - 1 phase	Factory	O	O	O	
	208/230V - 3 phase	Factory	O	O	O	O
	460V - 3 phase	Factory	O	O	O	O
	575V - 3 phase	Factory	O	O	O	O
Bottom Power Entry Kit		98W08	X	X	X	X
Disconnect	See Electrical/Electric Heat Tables for selection		OX	OX	OX	OX
GFI Service Outlets with Cover	15 amp non-powered, field-wired (208/230V, 460V only)	39U74	X	X	X	X
	¹ 20 amp non-powered, field-wired (208/230V, 460V, 575V)	39U77	X	X	X	X

¹ Canada requires a minimum 20 amp circuit. Select 20 amp, non-powered, field-wired GFI.

NOTE - Order numbers shown are for ordering field installed accessories.

OX - Field Installed or Configure to Order (factory installed)

O - Configure to Order (Factory Installed)

X - Field Installed.

OPTIONS / ACCESSORIES

Item	Order Number	Size				
		036	048	060	074	
ELECTRIC HEAT						
5 kW	208/240V-1ph	30U97	X	X	X	
	208/240V-3ph	30U98	X	X	X	
	460V-3ph	30U99	X	X	X	
	575V-3ph	30V01	X	X	X	
7.5 kW	208/240V-1ph	30V02	X	X	X	
	208/240V-3ph	30V03	X	X	X	X
	460V-3ph	30V04	X	X	X	X
	575V-3ph	30V05	X	X	X	X
10 kW	208/240V-1ph	30V06	X	X	X	
	208/240V-3ph	30V07	X	X	X	X
	460V-3ph	30V08	X	X	X	X
	575V-3ph	30V09	X	X	X	X
15 kW	208/240V-1ph	30V10	X	X	X	
	208/240V-3ph	30V11	X	X	X	X
	460V-3ph	30V12	X	X	X	X
	575V-3ph	30V13	X	X	X	X
22.5 kW	208/240V-1ph	30V14		X	X	
	208/240V-3ph	30V15		X	X	X
	460V-3ph	30V16		X	X	X
	575V-3ph	30V17		X	X	X
30 kW	208/240V-3ph	30V18				X
	460V-3ph	30V19				X
	575V-3ph	30V20				X
ELECTRICAL ACCESSORIES						
Unit Fuse Block (required) - See Electrical/Electric Heat Tables for Selection			X	X	X	X

NOTE - Order numbers shown are for ordering field installed accessories.

OX - Field Installed or Configure to Order (factory installed)

O - Configure to Order (Factory Installed)

X - Field Installed.

OPTIONS / ACCESSORIES

Item	Order Number	Size			
		036	048	060	074
ECONOMIZER					
Standard Economizer With Outdoor Air Hood (Not for Title 24)					
Standard Economizer (Downflow) Includes Barometric Relief Dampers and Exhaust Hood	14D94	X	X	X	X
Standard Economizer (Horizontal) Includes Barometric Relief Dampers and Exhaust Hood	14D92	X	X	X	X
Standard Economizer Controls (Not for Title 24)					
Single Enthalpy Control	21Z09	X	X	X	X
High Performance Economizer (Sensible Control) (Approved for California Title 24 Building Standards / AMCA Class 1A Certified)					
High Performance Economizer (Downflow) Includes Barometric Relief Dampers and Exhaust Hood	24J59	OX	OX	OX	OX
High Performance Economizer (Horizontal) Includes Barometric Relief Dampers and Exhaust Hood	24J60	X	X	X	X
High Performance Economizer Controls					
Single Enthalpy Control	23G26	X	X	X	X
OUTDOOR AIR					
Outdoor Air Dampers With Outdoor Air Hood					
Motorized	15D19	X	X	X	X
Manual	15D20	X	X	X	X
POWER EXHAUST FAN					
Standard Static (Downflow) 208/230V-1 or 3ph	21E01	X	X	X	X
Standard Static (Horizontal) 208/230V-1 or 3ph	24E01	X	X	X	X
575V Transformer Kit	59E02	X	X	X	X
INDOOR AIR QUALITY					
Indoor Air Quality (CO₂) Sensors					
Sensor - Wall-mount, off-white plastic cover with LCD display	77N39	X	X	X	X
Sensor - Wall-mount, black plastic case, no display, rated for plenum mounting	87N54	X	X	X	X
CO ₂ Sensor Duct Mounting Kit - for downflow applications	23Y47	X	X	X	X
Aspiration Box - for duct mounting non-plenum rated CO ₂ sensor (77N39)	90N43	X	X	X	X
ROOF CURBS					
Hybrid Roof Curbs, Downflow					
8 in. height	11F76	X	X	X	X
14 in. height	11F77	X	X	X	X
18 in. height	11F78	X	X	X	X
24 in. height	11F79	X	X	X	X
CEILING DIFFUSERS					
Step-Down - Order one	RTD9-65S	13K60	X	X	X
	RTD11-95S	13K61			X
Flush - Order one	FD9-65S	13K55	X	X	X
	FD11-95S	13K56			X

NOTE - Ceiling Diffuser Transitions are not furnished and must be field fabricated.
NOTE - Order 575V Transformer Kit with 208/230V Power Exhaust Fan for 575V applications.

NOTE - Order numbers shown are for ordering field installed accessories.
OX - Field Installed or Configure to Order (factory installed)
O - Configure to Order (Factory Installed)
X - Field Installed.

SPECIFICATIONS

Model		ZCD036S5B	ZCD048S5B	ZCD060S5B	ZCD074S5T
Nominal Tonnage		3	4	5	6
Efficiency Type		Standard	Standard	Standard	Standard
Blower Type		Single Speed Belt Drive	Single Speed Belt Drive	Single Speed Belt Drive	Two Speed Belt Drive
Cooling Performance	Gross Cooling Capacity (Btuh)	36,200	46,700	58,300	68,500
	¹ Net Cooling Capacity (Btuh)	35,000	45,500	57,000	67,000
	¹ AHRI Rated Air Flow (cfm)	1190	1380	1725	2200
	¹ SEER2 (Btuh/Watt)	13.4	13.4	13.4	---
	¹ EER2 (Btuh/Watt)	11.5	11.5	11.5	---
	¹ IEER (Btuh/Watt)	---	---	---	15.5
	¹ EER (Btuh/Watt)	---	---	---	11.2
	Total Unit Power (kW)	3.0	4.1	5.0	5.8
Sound Rating Number	dBA	78	80	78	84
Refrigerant	Type	R-454B	R-454B	R-454B	R-454B
	Charge Furnished	4 lbs. 1 oz.	4 lbs. 4 oz.	4 lbs. 10 oz.	5 lbs. 0 oz.
Electric Heat Available - page 29		5, 7.5, 10, 15 kW	5, 7.5, 10, 15, 22.5 kW		7.5, 15, 22.5, 30 kW
Compressor Type (one per unit)		Single-Stage Scroll (1)	Single-Stage Scroll (1)	Single-Stage Scroll (1)	Two-Stage Scroll (1)
Outdoor Coil	Net face area - ft. ²	15.2	15.2	19.9	19.9
	Rows	1	1	1	1
	Fins - in.	23	23	23	23
Outdoor Coil Fan	Motor HP (number and type)	(1) 1/4	(1) 1/4	(1) 1/4	(1) 1/3
	Rpm	825	825	825	1075
	Watts	315	315	315	365
	Diameter (Number) - in.	(1) 22	(1) 22	(1) 22	(1) 22
	Blades	4	4	4	3
	Total air volume - cfm	3700	3700	3700	4270
Indoor Coil	Net face area - ft. ²	7.2	7.2	7.2	9.5
	Rows	1	1	1	1
	Fins - in.	18	18	18	18
	Condensate drain size (NPT) - in.	(1) 3/4	(1) 3/4	(1) 3/4	(1) 3/4
	Expansion device type	Balanced Port Thermostatic Expansion Valve			
² Indoor Blower & Drive Selection	Nominal Motor HP 1ph	0.75	1.5	1.5	---
	3ph	1	1	1.5	2
	Maximum Usable Motor HP (US)	0.86, 1.15	1.7, 1.15	1.7	2.3
	Available Drive Kits	Kit #ZA01 678-1035 rpm	Kit #ZA02 803-1226 rpm	Kit #ZA03 906-1383 rpm	Kit #ZAA02 632-875 rpm
		Kit #ZA04 964-1471 rpm		Kit #ZA05 1098-1490 rpm	Kit #ZAA03 798-1105 rpm Kit #ZAA04 921-1228 rpm
	Wheel (Number) diameter x width - in.	(1) 10 x 10	(1) 10 x 10	(1) 10 x 10	(1) 15 x 9
Filters	Type	Disposable			
	Number and size - in.	(4) 14 x 20 x 2		(2) 16 x 20 x 2 (2) 20 x 20 x 2	
Line voltage data (Volts-Phase-Hz)		208/230-1-60 208/230-3-60 460-3-60 575-3-60	208/230-1-60 208/230-3-60 460-3-60 575-3-60	208/230-1-60 208/230-3-60 460-3-60 575-3-60	208/230-3-60 460-3-60 575-3-60

NOTE - Net capacity includes evaporator blower motor heat deduction. Gross capacity does not include evaporator blower motor heat deduction.

¹ AHRI Certified to AHRI Standard 210/240 or 340/360: 95°F outdoor air temperature and 80°F db/67°F wb entering evaporator air; minimum external duct static pressure.

² Using total air volume and system static pressure requirements determine from blower performance tables rpm and motor HP required. Maximum usable HP of motors furnished are shown. In Canada, nominal motor HP is also maximum usable motor HP output. If motors of comparable HP are used, be sure to keep within the service factor limitations outlined on the motor nameplate.

RATINGS

NOTE – For Temperatures and Capacities not shown in tables, see bulletin – Cooling Unit Rating Table Correction Factor Data in Miscellaneous Engineering Data section.

3 TON - ZCD036S5

Entering Wet Bulb Temperature	Total Air Volume	Outdoor Air Temperature Entering Outdoor Coil																			
		85°F					95°F					105°F					115°F				
		Total Cool Cap.	Comp. Motor Input	Sensible To Total Ratio (S/T)			Total Cool Cap.	Comp. Motor Input	Sensible To Total Ratio (S/T)			Total Cool Cap.	Comp. Motor Input	Sensible To Total Ratio (S/T)			Total Cool Cap.	Comp. Motor Input	Sensible To Total Ratio (S/T)		
				Dry Bulb					Dry Bulb					Dry Bulb					Dry Bulb		
cfm	kBtuh	kW	75°F	80°F	85°F	kBtuh	kW	75°F	80°F	85°F	kBtuh	kW	75°F	80°F	85°F	kBtuh	kW	75°F	80°F	85°F	
63°F	960	37.1	2.02	0.74	0.87	0.99	35.4	2.29	0.75	0.89	1	33.6	2.6	0.77	0.91	1	31.8	2.95	0.79	0.94	1
	1200	39.2	2.03	0.79	0.94	1	37.5	2.29	0.81	0.97	1	35.6	2.59	0.83	0.99	1	33.8	2.93	0.86	1	1
	1440	41.2	2.03	0.85	1	1	39.5	2.29	0.87	1	1	37.7	2.58	0.9	1	1	35.7	2.92	0.93	1	1
67°F	960	39.6	2.03	0.59	0.71	0.83	37.7	2.29	0.6	0.72	0.85	35.8	2.59	0.61	0.74	0.88	33.7	2.93	0.62	0.76	0.9
	1200	41.5	2.03	0.62	0.77	0.91	39.6	2.29	0.63	0.79	0.93	37.5	2.58	0.64	0.81	0.96	35.2	2.92	0.66	0.83	0.99
	1440	43.1	2.03	0.66	0.83	0.98	40.9	2.29	0.67	0.85	1	38.7	2.58	0.69	0.87	1	36.4	2.91	0.71	0.9	1
71°F	960	42.2	2.03	0.45	0.57	0.68	40.3	2.29	0.46	0.58	0.7	38.3	2.58	0.46	0.59	0.71	36	2.91	0.47	0.6	0.74
	1200	44.3	2.03	0.47	0.6	0.74	42.2	2.28	0.47	0.62	0.76	39.9	2.57	0.48	0.63	0.78	37.5	2.9	0.48	0.65	0.81
	1440	45.8	2.03	0.48	0.64	0.8	43.6	2.28	0.49	0.66	0.82	41.2	2.57	0.5	0.67	0.85	38.7	2.89	0.5	0.69	0.88

4 TON - ZCD048S5

Entering Wet Bulb Temperature	Total Air Volume	Outdoor Air Temperature Entering Outdoor Coil																			
		85°F					95°F					105°F					115°F				
		Total Cool Cap.	Comp. Motor Input	Sensible To Total Ratio (S/T)			Total Cool Cap.	Comp. Motor Input	Sensible To Total Ratio (S/T)			Total Cool Cap.	Comp. Motor Input	Sensible To Total Ratio (S/T)			Total Cool Cap.	Comp. Motor Input	Sensible To Total Ratio (S/T)		
				Dry Bulb					Dry Bulb					Dry Bulb					Dry Bulb		
cfm	kBtuh	kW	75°F	80°F	85°F	kBtuh	kW	75°F	80°F	85°F	kBtuh	kW	75°F	80°F	85°F	kBtuh	kW	75°F	80°F	85°F	
63°F	1280	49.3	2.87	0.74	0.87	0.99	47.3	3.27	0.75	0.89	1	45.2	3.69	0.77	0.91	1	42.9	4.17	0.79	0.94	1
	1600	52.2	2.87	0.8	0.95	1	50	3.27	0.81	0.97	1	47.8	3.7	0.83	0.99	1	45.5	4.18	0.85	1	1
	1920	54.6	2.86	0.85	1	1	52.6	3.27	0.87	1	1	50.4	3.7	0.9	1	1	48.1	4.19	0.92	1	1
67°F	1280	52.5	2.87	0.59	0.72	0.84	50.3	3.27	0.6	0.73	0.86	47.9	3.7	0.61	0.74	0.88	45.4	4.18	0.62	0.76	0.9
	1600	55	2.86	0.62	0.77	0.92	52.6	3.27	0.63	0.79	0.94	50.1	3.7	0.65	0.81	0.96	47.5	4.18	0.66	0.83	0.99
	1920	56.8	2.85	0.66	0.83	0.99	54.4	3.26	0.67	0.85	1	51.8	3.7	0.69	0.87	1	49.2	4.19	0.7	0.9	1
71°F	1280	56	2.86	0.46	0.57	0.69	53.6	3.26	0.46	0.58	0.7	51.2	3.7	0.46	0.59	0.72	48.6	4.19	0.47	0.6	0.73
	1600	58.5	2.84	0.47	0.61	0.75	56	3.26	0.47	0.62	0.76	53.3	3.7	0.48	0.63	0.78	50.6	4.18	0.48	0.65	0.81
	1920	60.4	2.83	0.48	0.65	0.81	57.8	3.25	0.49	0.66	0.83	54.9	3.69	0.5	0.68	0.85	52	4.18	0.5	0.69	0.88

5 TON - ZCD060S5

Entering Wet Bulb Temperature	Total Air Volume	Outdoor Air Temperature Entering Outdoor Coil																			
		85°F					95°F					105°F					115°F				
		Total Cool Cap.	Comp. Motor Input	Sensible To Total Ratio (S/T)			Total Cool Cap.	Comp. Motor Input	Sensible To Total Ratio (S/T)			Total Cool Cap.	Comp. Motor Input	Sensible To Total Ratio (S/T)			Total Cool Cap.	Comp. Motor Input	Sensible To Total Ratio (S/T)		
				Dry Bulb					Dry Bulb					Dry Bulb					Dry Bulb		
cfm	kBtuh	kW	75°F	80°F	85°F	kBtuh	kW	75°F	80°F	85°F	kBtuh	kW	75°F	80°F	85°F	kBtuh	kW	75°F	80°F	85°F	
63°F	1600	58.4	3.53	0.75	0.88	0.99	56.2	4.06	0.76	0.89	1	53.7	4.61	0.77	0.91	1	51	5.22	0.79	0.94	1
	2000	61.6	3.53	0.8	0.95	1	59.4	4	0.82	0.97	1	56.8	4.66	0.83	0.99	1	54.2	5.26	0.86	1	1
	2400	64.7	3.55	0.86	1	1	62.6	4.04	0.88	1	1	60	4.57	0.9	1	1	57.4	5.24	0.93	1	1
67°F	1600	62.1	3.53	0.59	0.72	0.84	59.6	4.01	0.6	0.73	0.86	57.2	4.66	0.61	0.74	0.88	54	5.26	0.62	0.76	0.9
	2000	65	3.55	0.63	0.78	0.92	62.6	4.04	0.64	0.79	0.94	59.8	4.57	0.65	0.81	0.96	56.6	5.29	0.66	0.83	0.99
	2400	67.4	3.56	0.66	0.84	0.99	64.5	4.04	0.68	0.86	1	61.8	4.58	0.69	0.88	1	58.5	5.26	0.71	0.9	1
71°F	1600	66.2	3.55	0.46	0.57	0.69	63.8	4.04	0.46	0.58	0.7	61	4.57	0.46	0.59	0.72	58	5.24	0.47	0.6	0.74
	2000	69.3	3.57	0.47	0.61	0.75	66.5	4.05	0.47	0.62	0.77	63.5	4.59	0.48	0.63	0.79	60.3	5.25	0.48	0.65	0.81
	2400	71.4	3.58	0.49	0.65	0.81	68.5	4.06	0.49	0.66	0.83	65.3	4.6	0.5	0.68	0.85	62	5.24	0.51	0.69	0.88

RATINGS

NOTE – For Temperatures and Capacities not shown in tables, see bulletin – Cooling Unit Rating Table Correction Factor Data in Miscellaneous Engineering Data section.

6 TON - ZCD074S5T (PART LOAD)

Entering Wet Bulb Temperature	Total Air Volume	Outdoor Air Temperature Entering Outdoor Coil																			
		65°F					75°F					85°F					95°F				
		Total Cool Cap.	Comp. Motor Input	Sensible To Total Ratio (S/T)			Total Cool Cap.	Comp. Motor Input	Sensible To Total Ratio (S/T)			Total Cool Cap.	Comp. Motor Input	Sensible To Total Ratio (S/T)			Total Cool Cap.	Comp. Motor Input	Sensible To Total Ratio (S/T)		
				Dry Bulb					Dry Bulb					Dry Bulb					Dry Bulb		
cfm	kBtuh	kW	75°F	80°F	85°F	kBtuh	kW	75°F	80°F	85°F	kBtuh	kW	75°F	80°F	85°F	kBtuh	kW	75°F	80°F	85°F	
63°F	1200	46.9	2.79	0.68	0.82	0.96	43.1	3.23	0.69	0.84	0.99	39.3	3.74	0.7	0.87	1	35.1	4.25	0.71	0.91	1
	1600	51.4	2.78	0.76	0.94	1	47.5	3.22	0.78	0.96	1	43.4	3.7	0.8	1	1	39.5	4.23	0.83	1	1
	2000	55.5	2.76	0.84	1	1	51.7	3.21	0.87	1	1	47.8	3.69	0.9	1	1	43.6	4.22	0.94	1	1
67°F	1200	50.9	2.78	0.53	0.66	0.78	47.1	3.22	0.53	0.66	0.8	42.9	3.7	0.53	0.67	0.83	38.7	4.25	0.52	0.69	0.86
	1600	55.4	2.76	0.58	0.73	0.89	51.1	3.21	0.58	0.75	0.93	46.6	3.7	0.59	0.77	0.96	42.1	4.23	0.59	0.8	1
	2000	58.5	2.75	0.63	0.81	0.99	53.8	3.2	0.64	0.84	1	49.3	3.69	0.65	0.87	1	44.5	4.22	0.66	0.91	1
71°F	1200	55.5	2.76	0.41	0.52	0.63	51.5	3.21	0.39	0.52	0.64	47.2	3.69	0.38	0.51	0.65	42.6	4.23	0.37	0.51	0.66
	1600	60	2.75	0.43	0.57	0.71	55.6	3.19	0.42	0.57	0.72	51	3.68	0.41	0.58	0.74	46.1	4.22	0.4	0.59	0.77
	2000	63.2	2.74	0.45	0.62	0.79	58.4	3.19	0.44	0.63	0.81	53.4	3.68	0.44	0.64	0.84	48.3	4.21	0.44	0.66	0.88

6 TON - ZCD074S5T (FULL LOAD)

Entering Wet Bulb Temperature	Total Air Volume	Outdoor Air Temperature Entering Outdoor Coil																			
		85°F					95°F					105°F					115°F				
		Total Cool Cap.	Comp. Motor Input	Sensible To Total Ratio (S/T)			Total Cool Cap.	Comp. Motor Input	Sensible To Total Ratio (S/T)			Total Cool Cap.	Comp. Motor Input	Sensible To Total Ratio (S/T)			Total Cool Cap.	Comp. Motor Input	Sensible To Total Ratio (S/T)		
				Dry Bulb					Dry Bulb					Dry Bulb					Dry Bulb		
cfm	kBtuh	kW	75°F	80°F	85°F	kBtuh	kW	75°F	80°F	85°F	kBtuh	kW	75°F	80°F	85°F	kBtuh	kW	75°F	80°F	85°F	
63°F	1920	70.2	4.01	0.74	0.88	1	67	4.55	0.76	0.91	1	63.9	5.14	0.77	0.93	1	60.3	5.8	0.79	0.97	1
	2400	74	4.06	0.8	0.97	1	70.8	4.59	0.82	1	1	67.5	5.2	0.85	1	1	64.1	5.86	0.88	1	1
	2880	77.8	4.1	0.87	1	1	74.6	4.65	0.89	1	1	71.1	5.25	0.92	1	1	67.4	5.91	0.96	1	1
67°F	1920	74.4	4.06	0.59	0.72	0.85	71	4.6	0.6	0.73	0.87	67.3	5.19	0.61	0.75	0.9	63.4	5.85	0.62	0.77	0.93
	2400	77.6	4.1	0.62	0.78	0.94	74.1	4.64	0.64	0.8	0.97	70.1	5.23	0.65	0.82	1	65.9	5.89	0.67	0.85	1
	2880	80.3	4.13	0.66	0.85	1	76.4	4.67	0.68	0.87	1	72.4	5.26	0.69	0.9	1	68.2	5.92	0.72	0.94	1
71°F	1920	79.3	4.12	0.45	0.57	0.69	75.6	4.66	0.45	0.58	0.71	71.6	5.25	0.46	0.59	0.72	67.5	5.91	0.46	0.6	0.75
	2400	82.5	4.16	0.46	0.61	0.75	78.6	4.7	0.47	0.62	0.78	74.7	5.31	0.48	0.64	0.79	69.9	5.95	0.48	0.65	0.83
	2880	84.8	4.19	0.48	0.65	0.82	80.8	4.72	0.49	0.67	0.84	76.7	5.34	0.5	0.68	0.87	71.6	5.97	0.51	0.71	0.91

BLOWER DATA

ZCD036S5B

BLOWER TABLE INCLUDES RESISTANCE FOR BASE UNIT ONLY WITH DRY INDOOR COIL AND AIR FILTERS IN PLACE.

FOR ALL UNITS ADD:

1 - Any factory installed options air resistance (heat section, economizer, wet coil, etc.).

2 - Any field installed accessories air resistance (duct resistance, diffuser, etc.).

See page 21 for blower motors and drives and wet coil and options/accessory air resistance data.

DOWNFLOW

Air Volume cfm	External Static - in. w.g.															
	0.10		0.20		0.30		0.40		0.50		0.60		0.70		0.80	
	RPM	BHP	RPM	BHP	RPM	BHP	RPM	BHP	RPM	BHP	RPM	BHP	RPM	BHP	RPM	BHP
900	562	0.16	629	0.18	699	0.19	771	0.20	840	0.22	904	0.24	962	0.26	1015	0.29
1000	586	0.18	654	0.20	725	0.21	796	0.23	864	0.25	927	0.27	983	0.30	1034	0.33
1100	612	0.20	681	0.22	752	0.24	823	0.26	890	0.28	950	0.31	1004	0.34	1054	0.37
1200	641	0.23	711	0.25	783	0.27	852	0.29	917	0.32	975	0.35	1027	0.39	1074	0.42
1300	673	0.25	744	0.28	815	0.30	882	0.33	944	0.36	1000	0.40	1050	0.44	1096	0.48
1400	709	0.29	779	0.32	849	0.34	914	0.37	973	0.41	1026	0.45	1074	0.49	1118	0.53
1500	747	0.33	816	0.36	883	0.39	945	0.42	1001	0.46	1052	0.51	1098	0.55	1141	0.59

Air Volume cfm	External Static - in. w.g.															
	0.90		1.00		1.10		1.20		1.30		1.40		1.50		1.60	
	RPM	BHP	RPM	BHP	RPM	BHP	RPM	BHP	RPM	BHP	RPM	BHP	RPM	BHP	RPM	BHP
900	1065	0.32	1112	0.35	1158	0.38	1202	0.41	1243	0.44	1284	0.48	1323	0.52	1364	0.55
1000	1082	0.36	1128	0.39	1173	0.42	1216	0.45	1257	0.49	1297	0.53	1336	0.57	1375	0.60
1100	1100	0.40	1145	0.44	1189	0.47	1231	0.51	1272	0.54	1311	0.58	1349	0.62	1388	0.66
1200	1119	0.45	1163	0.49	1206	0.52	1247	0.56	1287	0.60	1326	0.64	1364	0.68	1402	0.72
1300	1139	0.51	1182	0.55	1224	0.58	1265	0.62	1304	0.66	1342	0.71	1379	0.75	1416	0.79
1400	1160	0.57	1202	0.61	1243	0.65	1283	0.69	1322	0.73	1359	0.78	1396	0.82	1432	0.87
1500	1182	0.64	1223	0.68	1263	0.72	1303	0.76	1341	0.81	1378	0.85	1414	0.90	1449	0.94

HORIZONTAL

Air Volume cfm	External Static - in. w.g.															
	0.10		0.20		0.30		0.40		0.50		0.60		0.70		0.80	
	RPM	BHP	RPM	BHP	RPM	BHP	RPM	BHP	RPM	BHP	RPM	BHP	RPM	BHP	RPM	BHP
900	580	0.14	649	0.17	721	0.19	794	0.22	868	0.24	938	0.27	998	0.30	1045	0.33
1000	612	0.17	681	0.19	752	0.22	825	0.25	897	0.27	963	0.30	1017	0.33	1061	0.37
1100	647	0.20	717	0.23	788	0.26	858	0.28	926	0.31	986	0.34	1036	0.38	1077	0.41
1200	687	0.23	757	0.26	826	0.29	893	0.32	955	0.35	1008	0.39	1054	0.42	1095	0.46
1300	730	0.27	798	0.30	864	0.33	926	0.37	982	0.40	1030	0.44	1073	0.47	1116	0.51
1400	775	0.31	840	0.34	902	0.38	959	0.42	1009	0.46	1054	0.50	1096	0.53	1140	0.56
1500	820	0.36	881	0.40	939	0.44	993	0.49	1039	0.53	1082	0.56	1124	0.59	1168	0.62

Air Volume cfm	External Static - in. w.g.															
	0.90		1.00		1.10		1.20		1.30		1.40		1.50		1.60	
	RPM	BHP	RPM	BHP	RPM	BHP	RPM	BHP	RPM	BHP	RPM	BHP	RPM	BHP	RPM	BHP
900	1091	0.36	1140	0.38	1188	0.40	1232	0.43	1272	0.46	1309	0.49	1346	0.53	1383	0.57
1000	1105	0.40	1154	0.42	1201	0.45	1245	0.47	1284	0.50	1321	0.54	1357	0.58	1394	0.62
1100	1121	0.44	1169	0.47	1216	0.49	1259	0.52	1298	0.56	1335	0.60	1370	0.64	1406	0.69
1200	1139	0.49	1187	0.52	1234	0.54	1276	0.58	1314	0.62	1350	0.66	1385	0.71	1421	0.75
1300	1161	0.54	1208	0.57	1254	0.60	1295	0.64	1332	0.69	1366	0.73	1401	0.78	1436	0.83
1400	1185	0.59	1232	0.63	1276	0.67	1315	0.71	1351	0.76	1384	0.81	1419	0.86	1454	0.90
1500	1212	0.66	1257	0.70	1299	0.74	1337	0.79	1371	0.84	1404	0.89	1438	0.94	1473	0.99

BLOWER DATA

ZCD048S5B

BLOWER TABLE INCLUDES RESISTANCE FOR BASE UNIT ONLY WITH DRY INDOOR COIL AND AIR FILTERS IN PLACE.

FOR ALL UNITS ADD:

1 - Any factory installed options air resistance (heat section, economizer, wet coil, etc.).

2 - Any field installed accessories air resistance (duct resistance, diffuser, etc.).

See page 21 for blower motors and drives and wet coil and options/accessory air resistance data.

DOWNFLOW

Air Volume cfm	External Static - in. w.g.															
	0.10		0.20		0.30		0.40		0.50		0.60		0.70		0.80	
	RPM	BHP	RPM	BHP	RPM	BHP	RPM	BHP	RPM	BHP	RPM	BHP	RPM	BHP	RPM	BHP
1200	641	0.23	711	0.25	783	0.27	852	0.29	917	0.32	975	0.35	1027	0.39	1074	0.42
1300	673	0.25	744	0.28	815	0.30	882	0.33	944	0.36	1000	0.40	1050	0.44	1096	0.48
1400	709	0.29	779	0.32	849	0.34	914	0.37	973	0.41	1026	0.45	1074	0.49	1118	0.53
1500	747	0.33	816	0.36	883	0.39	945	0.42	1001	0.46	1052	0.51	1098	0.55	1141	0.59
1600	787	0.38	854	0.41	918	0.44	976	0.48	1030	0.52	1078	0.56	1123	0.61	1164	0.66
1700	827	0.43	892	0.46	952	0.49	1007	0.53	1058	0.58	1105	0.63	1148	0.68	1189	0.73
1800	868	0.48	929	0.52	986	0.55	1038	0.59	1087	0.64	1132	0.69	1174	0.75	1214	0.80
1900	907	0.54	966	0.58	1019	0.62	1069	0.66	1116	0.71	1160	0.77	1200	0.82	1240	0.88
2000	946	0.60	1001	0.65	1053	0.69	1101	0.74	1146	0.79	1188	0.85	1228	0.91	1267	0.98

Air Volume cfm	External Static - in. w.g.															
	0.90		1.00		1.10		1.20		1.30		1.40		1.50		1.60	
	RPM	BHP	RPM	BHP	RPM	BHP	RPM	BHP	RPM	BHP	RPM	BHP	RPM	BHP	RPM	BHP
1200	1119	0.45	1163	0.49	1206	0.52	1247	0.56	1287	0.60	1326	0.64	1364	0.68	1402	0.72
1300	1139	0.51	1182	0.55	1224	0.58	1265	0.62	1304	0.66	1342	0.71	1379	0.75	1416	0.79
1400	1160	0.57	1202	0.61	1243	0.65	1283	0.69	1322	0.73	1359	0.78	1396	0.82	1432	0.87
1500	1182	0.64	1223	0.68	1263	0.72	1303	0.76	1341	0.81	1378	0.85	1414	0.9	1449	0.94
1600	1205	0.70	1245	0.75	1284	0.79	1323	0.84	1361	0.88	1397	0.93	1432	0.98	1467	1.03
1700	1228	0.78	1268	0.82	1307	0.87	1345	0.92	1382	0.97	1417	1.02	1452	1.07	1486	1.11
1800	1253	0.85	1292	0.91	1331	0.96	1368	1.01	1404	1.06	1439	1.11	1473	1.16	1506	1.21
1900	1279	0.94	1317	1.00	1355	1.05	1392	1.10	1427	1.16	1461	1.21	1494	1.26	1527	1.31
2000	1305	1.04	1343	1.10	1380	1.15	1416	1.21	1450	1.26	1484	1.32	1516	1.37	1549	1.42

HORIZONTAL

Air Volume cfm	External Static - in. w.g.															
	0.10		0.20		0.30		0.40		0.50		0.60		0.70		0.80	
	RPM	BHP	RPM	BHP	RPM	BHP	RPM	BHP	RPM	BHP	RPM	BHP	RPM	BHP	RPM	BHP
1200	687	0.23	757	0.26	826	0.29	893	0.32	955	0.35	1008	0.39	1054	0.42	1095	0.46
1300	730	0.27	798	0.30	864	0.33	926	0.37	982	0.40	1030	0.44	1073	0.47	1116	0.51
1400	775	0.31	840	0.34	902	0.38	959	0.42	1009	0.46	1054	0.50	1096	0.53	1140	0.56
1500	820	0.36	881	0.40	939	0.44	993	0.49	1039	0.53	1082	0.56	1124	0.59	1168	0.62
1600	864	0.42	921	0.46	976	0.51	1027	0.56	1072	0.6	1113	0.63	1155	0.66	1198	0.69
1700	907	0.48	961	0.53	1013	0.58	1061	0.63	1105	0.67	1146	0.70	1187	0.73	1230	0.77
1800	948	0.56	999	0.61	1049	0.66	1096	0.71	1139	0.75	1180	0.78	1221	0.82	1262	0.86
1900	987	0.64	1037	0.69	1086	0.74	1132	0.79	1174	0.83	1214	0.86	1255	0.90	1295	0.95
2000	1028	0.73	1076	0.78	1123	0.83	1168	0.87	1210	0.91	1250	0.96	1289	1.00	1328	1.06

Air Volume cfm	External Static - in. w.g.															
	0.90		1.00		1.10		1.20		1.30		1.40		1.50		1.60	
	RPM	BHP	RPM	BHP	RPM	BHP	RPM	BHP	RPM	BHP	RPM	BHP	RPM	BHP	RPM	BHP
1200	1139	0.49	1187	0.52	1234	0.54	1276	0.58	1314	0.62	1350	0.66	1385	0.71	1421	0.75
1300	1161	0.54	1208	0.57	1254	0.60	1295	0.64	1332	0.69	1366	0.73	1401	0.78	1436	0.83
1400	1185	0.59	1232	0.63	1276	0.67	1315	0.71	1351	0.76	1384	0.81	1419	0.86	1454	0.90
1500	1212	0.66	1257	0.70	1299	0.74	1337	0.79	1371	0.84	1404	0.89	1438	0.94	1473	0.99
1600	1242	0.73	1284	0.77	1324	0.82	1360	0.88	1394	0.93	1426	0.99	1460	1.04	1495	1.08
1700	1272	0.81	1312	0.86	1350	0.92	1385	0.98	1418	1.04	1451	1.09	1485	1.14	1519	1.19
1800	1302	0.90	1341	0.96	1377	1.02	1411	1.08	1444	1.15	1477	1.20	1510	1.25	1544	1.30
1900	1334	1.01	1371	1.07	1406	1.13	1439	1.20	1471	1.26	1504	1.32	1537	1.37	1571	1.41
2000	1365	1.12	1401	1.19	1435	1.25	1468	1.32	1500	1.38	1532	1.44	1565	1.49	1598	1.53

BLOWER DATA

ZCD060S5B

BLOWER TABLE INCLUDES RESISTANCE FOR BASE UNIT ONLY WITH DRY INDOOR COIL AND AIR FILTERS IN PLACE.

FOR ALL UNITS ADD:

1 - Any factory installed options air resistance (heat section, economizer, wet coil, etc.).

2 - Any field installed accessories air resistance (duct resistance, diffuser, etc.).

See page 21 for blower motors and drives and wet coil and options/accessory air resistance data.

DOWNFLOW

Air Volume cfm	External Static - in. w.g.															
	0.10		0.20		0.30		0.40		0.50		0.60		0.70		0.80	
	RPM	BHP	RPM	BHP	RPM	BHP	RPM	BHP	RPM	BHP	RPM	BHP	RPM	BHP	RPM	BHP
1600	764	0.46	823	0.51	882	0.56	940	0.60	997	0.65	1048	0.69	1094	0.72	1140	0.75
1700	806	0.53	863	0.58	919	0.62	975	0.67	1028	0.71	1075	0.75	1119	0.78	1164	0.81
1800	849	0.60	903	0.65	957	0.69	1010	0.74	1058	0.78	1102	0.82	1145	0.85	1189	0.88
1900	892	0.68	944	0.72	995	0.77	1045	0.82	1089	0.86	1131	0.89	1174	0.92	1217	0.95
2000	935	0.76	984	0.81	1033	0.86	1079	0.91	1122	0.95	1163	0.97	1204	1.00	1247	1.03
2100	977	0.85	1024	0.90	1070	0.95	1114	1.00	1155	1.03	1196	1.06	1237	1.09	1278	1.12
2200	1018	0.95	1063	0.99	1107	1.04	1149	1.09	1190	1.12	1230	1.15	1270	1.18	1310	1.22
2300	1057	1.04	1100	1.09	1143	1.14	1185	1.18	1225	1.22	1264	1.25	1303	1.29	1342	1.33
2400	1096	1.14	1137	1.18	1179	1.23	1220	1.27	1260	1.31	1299	1.35	1337	1.40	1375	1.45

Air Volume cfm	External Static - in. w.g.															
	0.90		1.00		1.10		1.20		1.30		1.40		1.50		1.60	
	RPM	BHP	RPM	BHP	RPM	BHP	RPM	BHP	RPM	BHP	RPM	BHP	RPM	BHP	RPM	BHP
1600	1185	0.79	1229	0.81	1271	0.84	1313	0.86	1354	0.90	1393	0.94	1431	0.98	1468	1.03
1700	1208	0.84	1252	0.87	1294	0.90	1335	0.94	1375	0.98	1413	1.02	1449	1.07	1485	1.12
1800	1233	0.91	1276	0.94	1318	0.98	1358	1.02	1397	1.06	1434	1.11	1469	1.16	1504	1.21
1900	1261	0.98	1303	1.02	1343	1.06	1382	1.11	1420	1.16	1455	1.21	1490	1.26	1525	1.31
2000	1289	1.07	1330	1.11	1370	1.16	1407	1.21	1444	1.27	1478	1.32	1513	1.37	1547	1.42
2100	1319	1.16	1359	1.21	1397	1.27	1433	1.32	1468	1.38	1502	1.44	1536	1.49	1570	1.53
2200	1350	1.27	1388	1.32	1424	1.38	1459	1.45	1494	1.51	1527	1.56	1561	1.61	1594	1.65
2300	1380	1.38	1417	1.45	1452	1.51	1486	1.58	1520	1.63	1553	1.68	1587	1.73	1620	1.78
2400	1411	1.51	1446	1.58	1480	1.65	1514	1.71	1547	1.77	1580	1.81	1614	1.86	1648	1.90

HORIZONTAL

Air Volume cfm	External Static - in. w.g.															
	0.10		0.20		0.30		0.40		0.50		0.60		0.70		0.80	
	RPM	BHP	RPM	BHP	RPM	BHP	RPM	BHP	RPM	BHP	RPM	BHP	RPM	BHP	RPM	BHP
1600	752	0.40	818	0.45	882	0.50	943	0.55	999	0.59	1050	0.62	1097	0.66	1142	0.69
1700	792	0.46	855	0.52	917	0.56	975	0.61	1028	0.64	1077	0.68	1123	0.72	1166	0.75
1800	832	0.53	894	0.58	952	0.63	1007	0.67	1058	0.70	1105	0.74	1149	0.78	1192	0.82
1900	873	0.60	932	0.65	988	0.69	1040	0.73	1088	0.77	1134	0.81	1177	0.85	1219	0.90
2000	914	0.67	970	0.72	1023	0.76	1073	0.80	1120	0.85	1163	0.89	1205	0.94	1246	0.99
2100	955	0.74	1009	0.79	1059	0.84	1107	0.89	1152	0.93	1194	0.98	1235	1.03	1275	1.09
2200	995	0.83	1047	0.88	1095	0.93	1141	0.98	1184	1.03	1225	1.08	1265	1.14	1304	1.20
2300	1036	0.92	1085	0.97	1132	1.02	1175	1.08	1217	1.13	1257	1.19	1296	1.26	1334	1.32
2400	1077	1.01	1124	1.07	1168	1.13	1210	1.19	1251	1.25	1290	1.32	1328	1.39	1365	1.46

Air Volume cfm	External Static - in. w.g.															
	0.90		1.00		1.10		1.20		1.30		1.40		1.50		1.60	
	RPM	BHP	RPM	BHP	RPM	BHP	RPM	BHP	RPM	BHP	RPM	BHP	RPM	BHP	RPM	BHP
1600	1185	0.72	1228	0.75	1270	0.79	1310	0.83	1349	0.88	1387	0.93	1423	0.98	1459	1.03
1700	1209	0.78	1251	0.82	1292	0.87	1331	0.92	1370	0.97	1407	1.02	1443	1.07	1478	1.12
1800	1234	0.86	1275	0.91	1315	0.96	1354	1.01	1391	1.06	1428	1.11	1463	1.17	1498	1.22
1900	1260	0.95	1300	1.00	1340	1.05	1377	1.11	1414	1.16	1450	1.22	1485	1.27	1519	1.32
2000	1287	1.04	1326	1.10	1365	1.16	1402	1.21	1437	1.27	1472	1.33	1507	1.38	1541	1.43
2100	1314	1.15	1353	1.21	1391	1.27	1427	1.33	1462	1.39	1496	1.44	1530	1.50	1564	1.55
2200	1343	1.26	1381	1.33	1417	1.39	1453	1.45	1487	1.51	1521	1.56	1555	1.62	1589	1.67
2300	1372	1.39	1409	1.45	1445	1.52	1480	1.58	1513	1.64	1547	1.69	1580	1.75	1614	1.80
2400	1402	1.52	1438	1.59	1473	1.65	1507	1.71	1541	1.77	1574	1.83	1607	1.88	1641	1.93

BLOWER DATA

ZCD074S5T

BLOWER TABLE INCLUDES RESISTANCE FOR BASE UNIT ONLY WITH DRY INDOOR COIL AND AIR FILTERS IN PLACE.

FOR ALL UNITS ADD:

1 - Any factory installed options air resistance (heat section, economizer, wet coil, etc.).

2 - Any field installed accessories air resistance (duct resistance, diffuser, etc.).

See page 21 for blower motors and drives and wet coil and options/accessory air resistance data.

DOWNFLOW

Air Volume cfm	External Static - in. w.g.															
	0.10		0.20		0.30		0.40		0.50		0.60		0.70		0.80	
	RPM	BHP	RPM	BHP	RPM	BHP	RPM	BHP	RPM	BHP	RPM	BHP	RPM	BHP	RPM	BHP
1900	578	0.44	610	0.49	643	0.54	678	0.60	714	0.65	749	0.70	785	0.76	819	0.82
2000	600	0.50	632	0.56	665	0.61	699	0.66	734	0.71	769	0.77	803	0.83	837	0.90
2100	623	0.57	655	0.62	688	0.68	721	0.73	755	0.79	789	0.84	822	0.91	854	0.98
2200	647	0.65	678	0.70	711	0.75	743	0.81	776	0.86	809	0.93	841	1.00	872	1.06
2300	671	0.73	702	0.78	734	0.83	766	0.89	798	0.95	829	1.02	860	1.09	890	1.16
2400	696	0.81	726	0.87	757	0.92	788	0.98	819	1.04	850	1.11	880	1.19	909	1.26
2500	720	0.90	750	0.95	780	1.01	811	1.07	841	1.14	871	1.22	900	1.30	929	1.37
2600	745	0.99	774	1.05	804	1.11	834	1.17	864	1.25	893	1.33	921	1.41	949	1.49
2700	770	1.09	799	1.15	828	1.21	858	1.28	887	1.36	916	1.44	943	1.53	969	1.61
2800	795	1.19	824	1.25	853	1.33	882	1.40	911	1.48	939	1.56	965	1.65	990	1.73
2900	820	1.30	849	1.37	878	1.45	907	1.53	935	1.61	962	1.70	988	1.78	1012	1.86

Air Volume cfm	External Static - in. w.g.															
	0.90		1.00		1.10		1.20		1.30		1.40		1.50		1.60	
	RPM	BHP	RPM	BHP	RPM	BHP	RPM	BHP	RPM	BHP	RPM	BHP	RPM	BHP	RPM	BHP
1900	853	0.88	885	0.94	915	0.99	944	1.05	971	1.11	996	1.17	1021	1.23	1045	1.29
2000	869	0.96	899	1.01	929	1.07	957	1.13	984	1.19	1009	1.25	1033	1.31	1058	1.38
2100	885	1.04	915	1.10	944	1.15	971	1.22	997	1.28	1022	1.34	1046	1.40	1070	1.46
2200	902	1.13	931	1.19	959	1.24	986	1.31	1012	1.37	1036	1.43	1060	1.50	1084	1.56
2300	920	1.23	948	1.29	975	1.35	1001	1.41	1027	1.47	1051	1.53	1075	1.60	1098	1.66
2400	938	1.33	965	1.39	992	1.45	1017	1.52	1042	1.58	1066	1.64	1090	1.70	1113	1.77
2500	956	1.44	983	1.51	1009	1.57	1034	1.63	1059	1.69	1082	1.75	1105	1.82	1128	1.88
2600	975	1.56	1001	1.63	1026	1.69	1051	1.75	1075	1.81	1098	1.87	1121	1.93	1143	2.00
2700	995	1.68	1020	1.75	1044	1.81	1069	1.87	1092	1.93	1114	1.99	1136	2.06	1158	2.13
2800	1015	1.81	1039	1.87	1063	1.94	1086	2.00	1109	2.06	1131	2.12	1152	2.19	1174	2.26
2900	1035	1.94	1058	2.00	1081	2.07	1104	2.13	1126	2.19	1147	2.26	1168	2.33	1189	2.40

HORIZONTAL

Air Volume cfm	External Static - in. w.g.															
	0.10		0.20		0.30		0.40		0.50		0.60		0.70		0.80	
	RPM	BHP	RPM	BHP	RPM	BHP	RPM	BHP	RPM	BHP	RPM	BHP	RPM	BHP	RPM	BHP
1900	581	0.44	618	0.49	655	0.54	692	0.59	729	0.64	765	0.69	800	0.75	833	0.80
2000	602	0.50	639	0.55	676	0.61	713	0.66	749	0.71	784	0.76	818	0.82	850	0.88
2100	625	0.57	661	0.62	698	0.67	735	0.73	770	0.78	804	0.84	837	0.90	868	0.96
2200	648	0.64	685	0.69	721	0.75	757	0.80	791	0.86	824	0.92	856	0.98	886	1.05
2300	673	0.71	709	0.77	745	0.83	780	0.88	813	0.94	845	1.01	876	1.08	905	1.15
2400	699	0.79	734	0.85	769	0.91	803	0.97	835	1.04	866	1.11	896	1.18	924	1.25
2500	725	0.88	759	0.94	793	1.00	826	1.07	857	1.14	887	1.21	916	1.28	944	1.36
2600	752	0.97	785	1.04	818	1.10	850	1.17	880	1.25	909	1.32	937	1.40	964	1.48
2700	779	1.07	811	1.14	843	1.21	873	1.29	902	1.37	931	1.44	958	1.52	984	1.60
2800	805	1.18	837	1.26	868	1.33	897	1.41	925	1.49	952	1.57	979	1.66	1004	1.74
2900	832	1.30	863	1.38	892	1.46	921	1.54	948	1.63	974	1.71	1000	1.80	1024	1.88

Air Volume cfm	External Static - in. w.g.															
	0.90		1.00		1.10		1.20		1.30		1.40		1.50		1.60	
	RPM	BHP	RPM	BHP	RPM	BHP	RPM	BHP	RPM	BHP	RPM	BHP	RPM	BHP	RPM	BHP
1900	864	0.87	895	0.93	924	0.99	953	1.06	980	1.12	1007	1.18	1032	1.25	1056	1.31
2000	881	0.95	911	1.01	940	1.08	967	1.14	994	1.21	1020	1.27	1044	1.34	1068	1.40
2100	898	1.03	927	1.10	955	1.17	982	1.23	1008	1.30	1033	1.37	1057	1.43	1080	1.50
2200	916	1.12	944	1.19	971	1.26	998	1.33	1023	1.40	1047	1.47	1071	1.54	1093	1.60
2300	934	1.22	961	1.29	988	1.36	1014	1.43	1038	1.50	1062	1.58	1085	1.65	1107	1.71
2400	952	1.32	979	1.40	1005	1.47	1030	1.54	1054	1.62	1077	1.69	1099	1.76	1121	1.83
2500	971	1.43	997	1.51	1022	1.59	1046	1.66	1069	1.74	1092	1.81	1114	1.88	1135	1.95
2600	990	1.55	1015	1.63	1039	1.71	1063	1.79	1086	1.86	1108	1.94	1129	2.01	1150	2.07
2700	1009	1.68	1034	1.76	1057	1.84	1080	1.92	1102	1.99	1124	2.07	1145	2.14	1166	2.21
2800	1028	1.82	1052	1.9	1075	1.98	1097	2.06	1119	2.13	1140	2.21	1161	2.28	1182	2.34
2900	1048	1.96	1071	2.04	1093	2.12	1115	2.20	1136	2.28	1157	2.35	1177	2.42	1198	2.48

BLOWER DATA

BELT DRIVE KIT SPECIFICATIONS - ZCD036-060

Model	Motor HP		Voltage	Speeds	Drive Kits and RPM Range				
	Nominal	Maximum			ZA01	ZA02	ZA03	ZA04	ZA05
ZCD036	0.75	0.86	208/230V-1ph	1	678 - 1035	---	---	964 - 1471	---
	1	1.15	208/230V-3ph	1	678 - 1035	---	---	964 - 1471	---
ZCD048	1	1.15	208/230V-3ph	1	---	803 - 1226	---	---	---
	1.5	1.7	208/230V-1ph	1	---	803 - 1226	---	---	---
ZCD060	1.5	1.7	208/230V-1 or 3ph	1	---	---	906 - 1383	---	1098 - 1490

BELT DRIVE KIT SPECIFICATIONS - ZCD074

Model	Motor HP		Speeds	Drive Kits and RPM Range		
	Nominal	Maximum		ZAA02	ZAA03	ZAA04
ZCD074S5T	2	2.3	2	632 - 875	798 - 1105	921 - 1228

NOTE - Using total air volume and system static pressure requirements determine from blower performance tables rpm and motor HP required. Maximum usable HP of motors furnished are shown. In Canada, nominal motor HP is also maximum usable motor HP. If motors of comparable HP are used, be sure to keep within the service factor limitations outlined on the motor nameplate.

POWER EXHAUST FAN PERFORMANCE

Return Air System Static Pressure - in. w.g.	Air Volume Exhausted cfm
0.00	1865
0.05	1785
0.10	1710
0.15	1630
0.20	1545
0.25	1450
0.30	1350
0.35	1240

BLOWER DATA

OPTIONS / ACCESSORIES AIR RESISTANCE - in. w.g.

Air Volume cfm	Wet Indoor Coil		Electric Heat	Economizer	
	ZCD036, ZCD048	ZCD060, ZCD074		Downflow	Horizontal
900	0.01	---	0.05	0.03	0.04
1000	0.02	---	0.06	0.03	0.05
1100	0.02	---	0.08	0.04	0.05
1200	0.02	---	0.09	0.05	0.06
1300	0.03	---	0.12	0.05	0.07
1400	0.03	---	0.17	0.06	0.08
1500	0.04	---	0.22	0.07	0.08
1600	0.04	0.03	0.26	0.08	0.09
1700	0.05	0.03	0.30	0.09	0.10
1800	0.05	0.03	0.33	0.10	0.11
1900	0.06	0.04	0.33	0.11	0.12
2000	0.06	0.04	0.31	0.12	0.13
2100	---	0.05	0.27	0.13	0.14
2200	---	0.05	0.29	0.14	0.15
2300	---	0.05	0.31	0.15	0.16
2400	---	0.06	0.32	0.16	0.18
2500	---	0.06	0.34	0.18	0.19
2600	---	0.07	0.38	0.19	0.20
2700	---	0.07	0.42	0.20	0.21
2800	---	0.07	0.45	0.22	0.23
2900	---	0.08	0.49	0.23	0.24

BLOWER DATA

CEILING DIFFUSERS AIR RESISTANCE (in. w.g.)

Air Volume cfm	RTD9-65S Step-Down Diffuser			FD9-65S Flush Diffuser	RTD11-95S Step-Down Diffuser			FD11-95S Flush Diffuser
	2 Ends Open	1 Side & 2 Ends Open	All Ends & Sides Open		2 Ends Open	1 Side & 2 Ends Open	All Ends & Sides Open	
800	0.15	0.13	0.11	0.11	---	---	---	---
1000	0.19	0.16	0.14	0.14	---	---	---	---
1200	0.25	0.20	0.17	0.17	---	---	---	---
1400	0.33	0.26	0.20	0.20	---	---	---	---
1600	0.43	0.32	0.20	0.24	---	---	---	---
1800	0.56	0.40	0.30	0.30	0.13	0.11	0.09	0.09
2000	0.73	0.50	0.36	0.36	0.15	0.13	0.11	0.10
2200	0.95	0.63	0.44	0.44	0.18	0.15	0.12	0.12
2400	---	----	---	---	0.21	0.18	0.15	0.14
2600	---	----	---	---	0.24	0.21	0.18	0.17
2800	---	----	---	---	0.27	0.24	0.21	0.20
3000	---	----	---	---	0.32	0.29	0.25	0.25
3200	---	----	---	---	0.41	0.37	0.32	0.31
3400	---	----	---	---	0.50	0.45	0.39	0.37
3600	---	----	---	---	0.61	0.54	0.48	0.44

CEILING DIFFUSER AIR THROW DATA

Air Volume - cfm	¹ Effective Throw - ft.	
	RTD9-65S	FD9-65S
800	10 - 17	14 - 18
1000	10 - 17	15 - 20
1200	11 - 18	16 - 22
1400	12 - 19	17 - 24
1600	12 - 20	18 - 25
1800	13 - 21	20 - 28
2000	14 - 23	21 - 29
2200	16 - 25	22 - 30
Model	RTD11-95S	FD11-95S
2600	24 - 29	19 - 24
2800	25 - 30	20 - 28
3000	27 - 33	21 - 29
3200	28 - 35	22 - 29
3400	30 - 37	22 - 30
3600	25 - 33	22 - 24

¹ Effective throw based on terminal velocities of 75 ft. per minute.

ELECTRICAL/ELECTRIC HEAT DATA

3 TON

Model		ZCD036S5			
		208/230V - 1 Ph	208/230V - 3 Ph	460V - 3 Ph	575V - 3 Ph
¹ Voltage - 60Hz					
Compressor (Non-Inverter)	Rated Load Amps	14.4	9	4.1	3.3
	Locked Rotor Amps	86	70	39	29
Outdoor Fan Motor	Full Load Amps (1 Non-ECM)	1.7	1.7	0.9	0.7
Power Exhaust (1) 0.33 HP	Full Load Amps	2.4	2.4	1.3	1
Service Outlet 115V GFI (amps)		15	15	15	20
Indoor Blower Motor	Horsepower	0.75	1	1	1
	Full Load Amps	7.6	4.6	2.1	1.7
² Maximum Overcurrent Protection (MOCP)	Unit Only	40	25	15	15
	With (1) 0.33 HP Power Exhaust	40	25	---	15
³ Minimum Circuit Ampacity (MCA)	Unit Only	28	18	9	7
	With (1) 0.33 HP Power Exhaust	30	20	---	8

ELECTRIC HEAT DATA

Electric Heat Voltage			208	240	208	240	480	600
² Maximum Overcurrent Protection (MOCP)	Unit+ Electric Heat	5 kW	40	40	25	25	15	15
		7.5 kW	45	50	30	30	15	15
		10 kW	60	70	35	40	20	15
		15 kW	80	90	45	60	30	25
³ Minimum Circuit Ampacity (MCA)	Unit+ Electric Heat	5 kW	33	36	19	21	11	9
		7.5 kW	44	49	26	29	14	12
		10 kW	55	62	32	36	18	15
		15 kW	78	88	45	51	26	21
² Maximum Overcurrent Protection (MOCP)	Unit+ Electric Heat and (1) 0.33 HP Power Exhaust	5 kW	40	40	25	25	---	15
		7.5 kW	50	60	30	35	---	15
		10 kW	60	70	35	40	---	20
		15 kW	90	100	50	60	---	25
³ Minimum Circuit Ampacity (MCA)	Unit+ Electric Heat and (1) 0.33 HP Power Exhaust	5 kW	36	39	22	24	---	10
		7.5 kW	47	52	29	32	---	13
		10 kW	58	65	35	39	---	16
		15 kW	81	91	48	54	---	22

NOTE - All units have a minimum Short Circuit Current Rating (SCCR) of 5000 amps.

¹ Extremes of operating range are plus and minus 10% of line voltage.

² HACR type breaker or fuse.

³ Refer to National or Canadian Electrical Code manual to determine wire, fuse and disconnect size requirements.

ELECTRICAL/ELECTRIC HEAT DATA
4 TON

Model		ZCD048S5			
		208/230V - 1 Ph	208/230V - 3 Ph	460V - 3 Ph	575V - 3 Ph
¹ Voltage - 60Hz					
Compressor (Non-Inverter)	Rated Load Amps	19.4	12	6.3	4.4
	Locked Rotor Amps	102	123	60	41
Outdoor Fan Motor	Full Load Amps (1 Non-ECM)	1.7	1.7	0.9	0.7
Power Exhaust (1) 0.33 HP	Full Load Amps	2.4	2.4	1.3	1
Service Outlet 115V GFI (amps)		15	15	15	20
Indoor Blower Motor	Horsepower	1.5	1	1	1
	Full Load Amps	11	4.6	2.1	1.7
² Maximum Overcurrent Protection (MOCP)	Unit Only	50	30	15	15
	With (1) 0.33 HP Power Exhaust	50	35	---	15
³ Minimum Circuit Ampacity (MCA)	Unit Only	37	22	11	8
	With (1) 0.33 HP Power Exhaust	40	24	---	9

ELECTRIC HEAT DATA

Electric Heat Voltage			208	240	208	240	480	600
² Maximum Overcurrent Protection (MOCP)	Unit+ Electric Heat	5 kW	50	50	30	30	15	15
		7.5 kW	50	60	30	30	15	15
		10 kW	60	70	35	40	20	15
		15 kW	90	100	45	60	30	25
		22.5 kW	125	150	70	80	40	30
³ Minimum Circuit Ampacity (MCA)	Unit+ Electric Heat	5 kW	37	40	22	22	11	9
		7.5 kW	48	53	26	29	14	12
		10 kW	59	66	32	36	18	15
		15 kW	82	92	45	51	26	21
		22.5 kW	116	131	65	74	37	30
² Maximum Overcurrent Protection (MOCP)	Unit+ Electric Heat and (1) 0.33 HP Power Exhaust	5 kW	50	50	35	35	---	15
		7.5 kW	60	60	35	35	---	15
		10 kW	70	70	35	40	---	20
		15 kW	90	100	50	60	---	25
		22.5 kW	125	150	70	80	---	35
³ Minimum Circuit Ampacity (MCA)	Unit+ Electric Heat and (1) 0.33 HP Power Exhaust	5 kW	40	43	24	24	---	10
		7.5 kW	51	56	29	32	---	13
		10 kW	62	69	35	39	---	16
		15 kW	85	95	48	54	---	22
		22.5 kW	119	134	68	77	---	31

NOTE - All units have a minimum Short Circuit Current Rating (SCCR) of 5000 amps.

¹ Extremes of operating range are plus and minus 10% of line voltage.

² HACR type breaker or fuse.

³ Refer to National or Canadian Electrical Code manual to determine wire, fuse and disconnect size requirements.

ELECTRICAL/ELECTRIC HEAT DATA

5 TON

Model		ZCD060S5			
		208/230V - 1 Ph	208/230V - 3 Ph	460V - 3 Ph	575V - 3 Ph
¹ Voltage - 60Hz					
Compressor (Non-Inverter)	Rated Load Amps	23.7	16	7.1	6.4
	Locked Rotor Amps	157	156	69	47.8
Outdoor Fan Motor	Full Load Amps (1 Non-ECM)	1.7	1.7	0.9	0.7
Power Exhaust (1) 0.33 HP	Full Load Amps	2.4	2.4	1.3	1
Service Outlet 115V GFI (amps)		15	15	15	20
Indoor Blower Motor	Horsepower	1.5	1.5	1.5	1.5
	Full Load Amps	11	6.6	3	2.4
² Maximum Overcurrent Protection (MOCP)	Unit Only	60	40	15	15
	With (1) 0.33 HP Power Exhaust	60	45	---	15
³ Minimum Circuit Ampacity (MCA)	Unit Only	43	29	13	12
	With (1) 0.33 HP Power Exhaust	45	31	---	13

ELECTRIC HEAT DATA

Electric Heat Voltage		208	240	208	240	480	600	
² Maximum Overcurrent Protection (MOCP)	Unit+ Electric Heat	5 kW	60	60	40	40	15	15
		7.5 kW	60	60	40	40	20	15
		10 kW	60	70	40	40	20	20
		15 kW	90	100	50	60	30	25
		22.5 kW	125	150	70	80	40	35
³ Minimum Circuit Ampacity (MCA)	Unit+ Electric Heat	5 kW	43	43	29	29	13	12
		7.5 kW	48	53	29	31	16	13
		10 kW	59	66	35	39	19	16
		15 kW	82	92	48	54	27	22
		22.5 kW	116	131	67	76	38	31
² Maximum Overcurrent Protection (MOCP)	Unit+ Electric Heat and (1) 0.33 HP Power Exhaust	5 kW	60	60	45	45	---	15
		7.5 kW	60	60	45	45	---	15
		10 kW	70	70	45	45	---	20
		15 kW	90	100	60	60	---	25
		22.5 kW	125	150	70	80	---	35
³ Minimum Circuit Ampacity (MCA)	Unit+ Electric Heat and (1) 0.33 HP Power Exhaust	5 kW	45	45	31	31	---	13
		7.5 kW	51	56	31	34	---	14
		10 kW	62	69	38	42	---	17
		15 kW	85	95	51	57	---	23
		22.5 kW	119	134	70	79	---	32

NOTE - All units have a minimum Short Circuit Current Rating (SCCR) of 5000 amps.

¹ Extremes of operating range are plus and minus 10% of line voltage.

² HACR type breaker or fuse.

³ Refer to National or Canadian Electrical Code manual to determine wire, fuse and disconnect size requirements.

ELECTRICAL/ELECTRIC HEAT DATA

6 TON

Model		ZCD074S5T		
¹ Voltage - 60Hz		208/230V - 3 Ph	460V - 3 Ph	575V - 3 Ph
Compressor (Non-Inverter)	Rated Load Amps	19.2	9.1	6.2
	Locked Rotor Amps	162.3	70.8	58.2
Outdoor Fan Motors	Full Load Amps (1 Non-ECM)	1.7	1	0.9
Power Exhaust (1) 0.33 HP	Full Load Amps	2.4	1.3	1
Service Outlet 115V GFI (amps)		15	15	20
Indoor Blower Motor	Horsepower	2	2	2
	Full Load Amps	7.5	3.4	2.7
² Maximum Overcurrent Protection (MOCP)	Unit Only	50	20	15
	with (1) 0.33 HP Power Exhaust	50	---	15
³ Minimum Circuit Ampacity (MCA)	Unit Only	34	16	12
	with (1) 0.33 HP Power Exhaust	36	---	13

ELECTRIC HEAT DATA

Electric Heat Voltage			208V	240V	480V	600V
² Maximum Overcurrent Protection (MOCP)	Unit + Electric Heat	7.5 kW	50	50	20	15
		10 kW	50	50	20	20
		15 kW	50	60	30	25
		22.5 kW	70	80	40	35
		30 kW	90	100	50	40
³ Minimum Circuit Ampacity (MCA)	Unit + Electric Heat	7.5 kW	34	34	16	13
		10 kW	36	40	20	16
		15 kW	49	55	27	22
		22.5 kW	69	78	39	31
		30 kW	88	100	50	40
² Maximum Overcurrent Protection (MOCP)	Unit+ Electric Heat and (1) 0.33 HP Power Exhaust	7.5 kW	50	50	---	15
		10 kW	50	50	---	20
		15 kW	60	60	---	25
		22.5 kW	80	90	---	35
		30 kW	100	110	---	45
³ Minimum Circuit Ampacity (MCA)	Unit+ Electric Heat and (1) 0.33 HP Power Exhaust	7.5 kW	36	36	---	14
		10 kW	39	43	---	17
		15 kW	52	58	---	23
		22.5 kW	72	81	---	32
		30 kW	91	103	---	41

NOTE - All units have a minimum Short Circuit Current Rating (SCCR) of 5000 amps.

¹ Extremes of operating range are plus and minus 10% of line voltage.

² HACR type breaker or fuse.

³ Refer to National or Canadian Electrical Code manual to determine wire, fuse and disconnect size requirements.

ELECTRICAL ACCESSORIES

DISCONNECTS

3 TON | ZCD036S5

Motor Horsepower	0.75		1		1	1
Electric Heat Voltage	208V-1 Ph	240V-1 Ph	208V-3 Ph	240V-3 Ph	480V-3 Ph	600V-3 Ph
Unit Only	39U72	39U72	39U72	39U72	39U72	39U72
+ Power Exhaust	39U72	39U72	39U72	39U72	39U72	39U72
+ Electric Heat 5 kW to 15 kW	39U72	39U72	39U72	39U72	39U72	39U72
+ Power Exhaust + Electric Heat 5 kW to 15 kW	39U72	39U72	39U72	39U72	- - -	39U72

4 TON | ZCD048S5

Motor Horsepower	1.5		1		1	1
Electric Heat Voltage	208V-1 Ph	240V-1 Ph	208V-3 Ph	240V-3 Ph	480V-3 Ph	600V-3 Ph
Unit Only	39U72	39U72	39U72	39U72	39U72	39U72
+ Power Exhaust	39U72	39U72	39U72	39U72	39U72	39U72
+ Electric Heat 5 kW to 10 kW	39U72	39U72	39U72	39U72	39U72	39U72
+ Electric Heat 15 kW	¹ N/A	39U72	¹ N/A	39U72	39U72	39U72
+ Electric Heat 22.5 kW	¹ N/A	¹ N/A	¹ N/A	¹ N/A	39U72	39U72
+ Power Exhaust + Electric Heat 5 kW to 10 kW	39U72	39U72	39U72	39U72	- - -	39U72
+ Power Exhaust + Electric Heat 15 kW	¹ N/A	39U72	¹ N/A	39U72	- - -	39U72
+ Power Exhaust + Electric Heat 22.5 kW	¹ N/A	¹ N/A	¹ N/A	¹ N/A	- - -	39U72

5 TON | ZCD060S5

Motor Horsepower	1.5		1.5		1.5	1.5
Electric Heat Voltage	208V-1 Ph	240V-1 Ph	208V-3 Ph	240V-3 Ph	480V-3 Ph	600V-3 Ph
Unit Only	39U71	39U71	39U71	39U71	39U71	39U71
+ Power Exhaust	39U71	39U71	39U71	39U71	39U71	39U71
+ Electric Heat 5 kW to 10 kW	39U71	39U71	39U71	39U71	39U71	39U71
+ Electric Heat 15 kW	¹ N/A	39U71	¹ N/A	39U71	39U71	39U71
+ Electric Heat 22.5 kW	¹ N/A	¹ N/A	¹ N/A	¹ N/A	39U71	39U71
+ Power Exhaust + Electric Heat 5 kW to 10 kW	39U71	39U71	39U71	39U71	- - -	39U71
+ Power Exhaust + Electric Heat 15 kW	¹ N/A	39U71	¹ N/A	39U71	- - -	39U71
+ Power Exhaust + Electric Heat 22.5 kW	¹ N/A	¹ N/A	¹ N/A	¹ N/A	- - -	39U71

6 TON | ZCD074S55T

Motor Horsepower	2		2		2	2
Electric Heat Voltage	208V-3ph		240V-3 Ph		480V-3 Ph	600V-3 Ph
Unit Only	39U71		39U71		39U71	39U71
+ Power Exhaust	39U71		39U71		39U71	39U71
+ Electric Heat 7.5 kW to 15 kW	39U71		39U71		39U71	39U71
+ Electric Heat 22.5 kW	¹ N/A		¹ N/A		39U71	39U71
+ Electric Heat 30 kW	¹ N/A		¹ N/A		39U71	39U71
+ Power Exhaust + Electric Heat 7.5 kW to 15 kW	39U71		39U71		- - -	39U71
+ Power Exhaust + Electric Heat 22.5 kW	¹ N/A		¹ N/A		- - -	39U71
+ Power Exhaust + Electric Heat 30 kW	¹ N/A		¹ N/A		- - -	39U71

Disconnect - **39U72** - 80A (Short Cabinet)
39U71 - 80A (Tall Cabinet)

¹ Disconnect must be field furnished.

ELECTRICAL ACCESSORIES**FUSE BLOCKS****3 TON | ZCD036S5**

Motor Horsepower	0.75		1		1	1
Electric Heat Voltage	208V-1 Ph	240V-1 Ph	208V-3 Ph	240V-3 Ph	480V-3 Ph	600V-3 Ph
Unit Only	10A26	10A26	10A27	10A27	10A29	10A29
Unit + Power Exhaust	10A26	10A26	10A27	10A27	---	10A29

4 TON | ZCD048S5

Motor Horsepower	1.5		1		1	1
Electric Heat Voltage	208V-1 Ph	240V-1 Ph	208V-3 Ph	240V-3 Ph	480V-3 Ph	600V-3 Ph
Unit Only	10A26	10A26	10A27	10A27	10A29	10A29
Unit + Power Exhaust	10A26	10A26	10A27	10A27	---	10A29

5 TON | ZCD060S5

Motor Horsepower	1.5		1.5		1.5	1.5
Electric Heat Voltage	208V-1 Ph	240V-1 Ph	208V-3 Ph	240V-3 Ph	480V-3 Ph	600V-3 Ph
Unit Only	10A26	10A26	10A28	10A28	10A29	10A29
Unit + Power Exhaust	10A26	10A26	10A28	10A28	---	10A29

6 TON | ZCD074S55T

Motor Horsepower	2		2		2	2
Electric Heat Voltage	208V-3 Ph		240V-3 Ph		480V-3 Ph	600V-3 Ph
Unit Only	10A28		10A28		10A29	10A29
Unit + Power Exhaust	10A28		10A28		---	10A29

ELECTRIC HEAT CAPACITIES

Input Voltage	5 kW			7.5 kW			10 kW		
	Stages	kW input	Btuh Output	Stages	kW input	Btuh Output	Stages	kW input	Btuh Output
208	1	3.8	12,800	1	5.6	19,200	1	7.5	25,600
220	1	4.2	14,300	1	6.3	21,500	1	8.4	28,700
230	1	4.6	15,700	1	6.9	23,500	1	9.2	31,400
240	1	5.0	17,100	1	7.5	25,600	1	10.0	34,200
440	1	4.2	14,300	1	6.3	21,500	1	8.4	28,700
460	1	4.6	15,700	1	6.9	23,500	1	9.2	31,400
480	1	5.0	17,100	1	7.5	25,600	1	10.0	34,200
550	1	4.2	14,300	1	6.3	21,500	1	8.4	28,700
575	1	4.6	15,700	1	6.9	23,500	1	9.2	31,400
600	1	5.0	17,100	1	7.5	25,600	1	10.0	34,200
Input Voltage	15 kW			22.5 kW			30 kW		
	Stages	kW input	Btuh Output	Stages	kW input	Btuh Output	Stages	kW input	Btuh Output
208	1	11.2	38,400	1	16.9	57,700	1	22.5	76,800
220	1	12.6	43,000	1	18.9	64,500	1	25.2	86,000
230	1	13.8	47,000	1	20.7	70,700	1	27.5	93,900
240	1	15.0	51,200	1	22.5	76,800	1	30.0	102,400
440	1	12.6	43,000	1	18.9	64,500	1	25.2	86,000
460	1	13.8	47,000	1	20.7	70,700	1	27.5	93,900
480	1	15.0	51,200	1	22.5	76,800	1	30.0	102,400
550	1	12.6	43,000	1	18.9	64,500	1	25.2	86,000
575	1	13.8	47,000	1	20.7	70,700	1	27.5	93,900
600	1	15.0	51,200	1	22.5	76,800	1	30.0	102,400

FIELD WIRING NOTES

- For use with copper wiring only
- Field wiring not furnished
- All wiring must conform to NEC or CEC and local electrical codes
- For specific wiring information, please refer to the installation instructions

OUTDOOR SOUND DATA

Size	Octave Band Sound Power Levels dBA, re 10 ⁻¹² Watts - Center Frequency - Hz							1 Sound Rating Number dBA
	125	250	500	1000	2000	4000	8000	
036	66	70	73	72	70	67	60	78
048	68	71	75	74	71	68	63	80
060	64	68	72	73	69	67	63	78
074	73	76	80	78	73	68	66	84

¹ Sound Rating Number according to AHRI Standard 270-2008. Sound Rating Number is the overall A-Weighted Sound Power Level, (LWA), dB (100 Hz to 10,000 Hz).

UNIT CLEARANCES

UNIT WITH DOWNFLOW ECONOMIZER

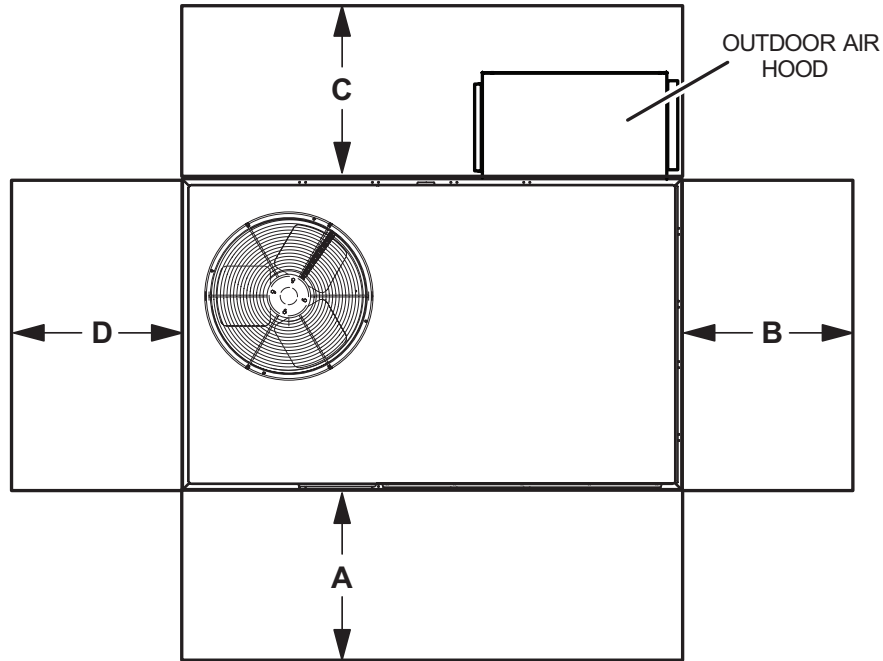

UNIT WITH HORIZONTAL ECONOMIZER

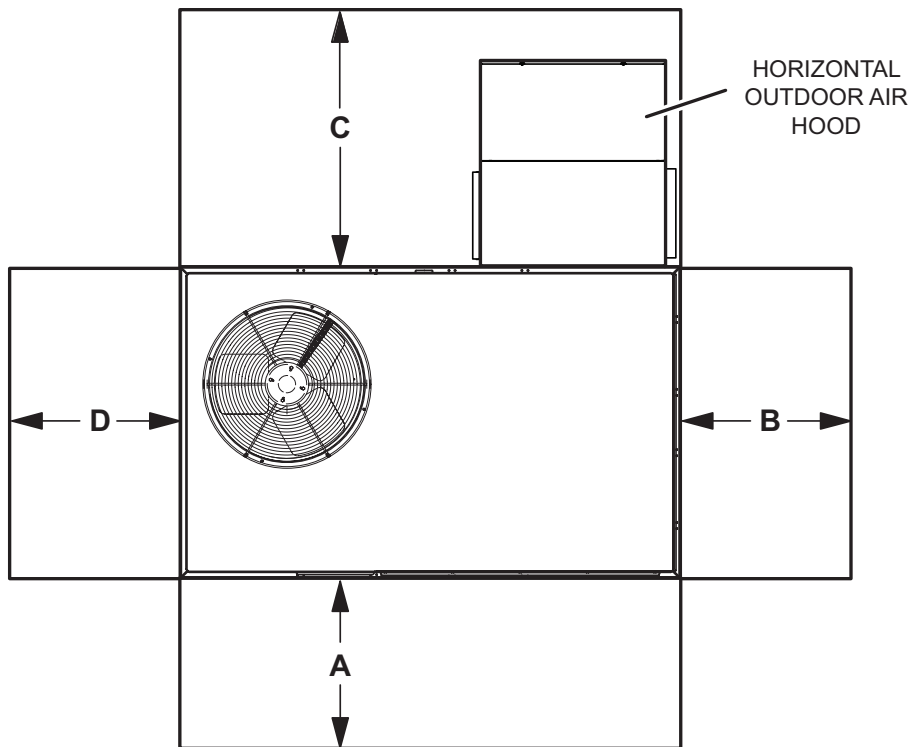

1 Unit Clearance	A		B		C Downflow		C Horizontal		D		Top Clearance
	in.	mm	in.	mm	in.	mm	in.	mm	in.	mm	
Service Clearance	36	914	36	914	36	914	60	1524	36	914	Unobstructed
Minimum Operation Clearance	36	914	36	914	36	914	60	1524	36	914	

NOTE - Entire perimeter of unit base requires support when elevated above the mounting surface.

¹ Service Clearance - Required for removal of serviceable parts.

Minimum Operation Clearance - Required clearance for proper unit operation.

WEIGHT DATA

Model	Net				Shipping			
	Base		Max.		Base		Max.	
	lbs.	kg	lbs.	kg	lbs.	kg	lbs.	kg
ZCD036S	437	198	507	230	442	201	512	249
ZCD048S	446	202	516	234	451	205	521	236
ZCD060S	531	241	584	265	536	243	589	267
ZCD074S	572	259	626	284	577	262	631	286

Base Unit - The unit with NO OPTIONS.

Max. Unit - The unit with ALL OPTIONS Installed. (Economizer, etc.)

FACTORY / FIELD INSTALLED OPTIONS AND ACCESSORIES - NET WEIGHTS

Description	lbs.	kg	
ECONOMIZER / OUTDOOR AIR / POWER EXHAUST			
Economizer			
Downflow	75	34	
Horizontal	102	46	
Outdoor Air Dampers			
Motorized	39	18	
Manual	29	13	
Power Exhaust			
Downflow	54	24	
Horizontal	41	19	
ELECTRIC HEAT			
5 kW	25	11	
7.5 kW	26	12	
10 kW	27	12	
15 kW	27	12	
22.5 kW	29	13	
30 kW	30	14	
COMBINATION COIL/HAIL GUARDS			
036/048	45	20	
060/074	50	23	
ROOF CURBS			
Hybrid Roof Curbs, Downflow			
8 in. height	63	29	
14 in. height	83	38	
18 in. height	93	42	
24 in. height	113	51	
CEILING DIFFUSERS			
Step-Down	RTD9-65S	80	36
	RTD11-95S	118	54
Flush	FD9-65S	80	36
	FD11-95S	118	54

DIMENSIONS - UNIT

Size	CORNER WEIGHTS																CENTER OF GRAVITY							
	AA				BB				CC				DD				EE				FF			
	Base		Max.		Base		Max.		Base		Max.		Base		Max.		Base		Max.		Base		Max.	
	lbs.	kg	lbs.	kg	lbs.	kg	lbs.	kg	lbs.	kg	lbs.	kg	lbs.	kg	in.	mm	in.	mm	in.	mm	in.	mm	in.	mm
036	117	53	134	61	112	51	129	59	120	54	138	63	125	57	143	65	38.75	984	36.75	933	22.75	578	24.5	622
048	119	54	136	62	115	52	131	59	122	55	140	64	127	58	145	66	38.75	984	36.75	933	22.75	578	24.5	622
060	156	71	176	80	140	64	158	72	129	59	145	66	143	65	161	73	40	1016	38	965	24.5	622	26	660
074	136	62	149	68	136	62	149	68	148	67	162	73	148	67	162	73	38	965	36	914	22.5	572	24	610

Base Unit - The unit with NO OPTIONS.

Max. Unit - The unit with ALL OPTIONS Installed. (Economizer, largest blower motor, etc.).

BOTTOM POWER ENTRY

Holes required for Optional Bottom Power Entry Kit

	Threaded Conduit Fittings (Provided in Kit)	Wire Use	Hole Diameter Required in Unit Base (Max.)
A	1/2	ACC	7/8 (23)
B	1/2	24V	7/8 (23)
C	3/4	POWER	1-1/8 (29)

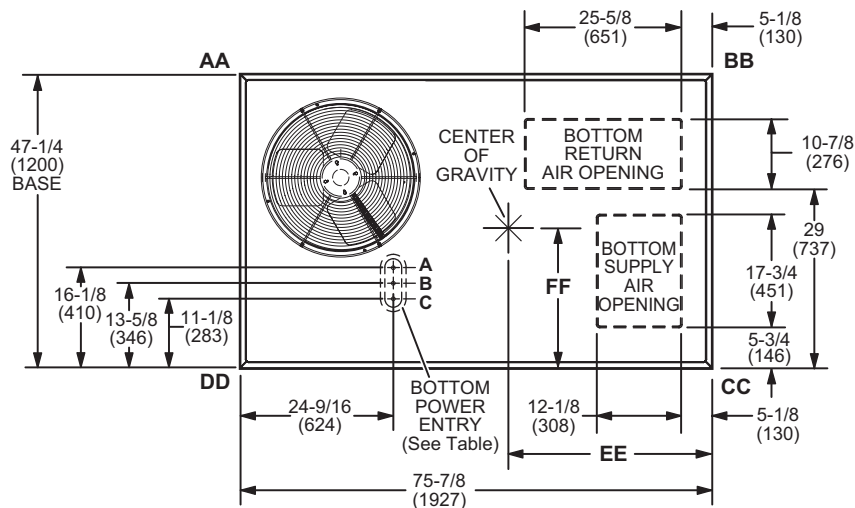

TOP VIEW (Base)

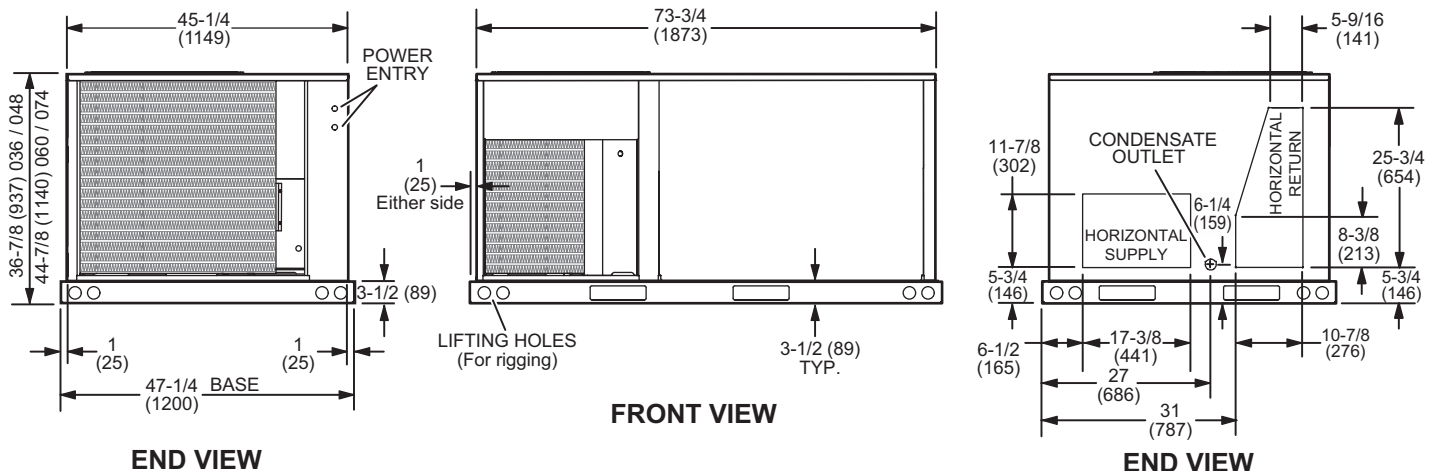

END VIEW

FRONT VIEW

END VIEW

DIMENSIONS - ACCESSORIES

OUTDOOR AIR HOOD DETAIL FOR OPTIONAL ECONOMIZER (Downflow Applications)

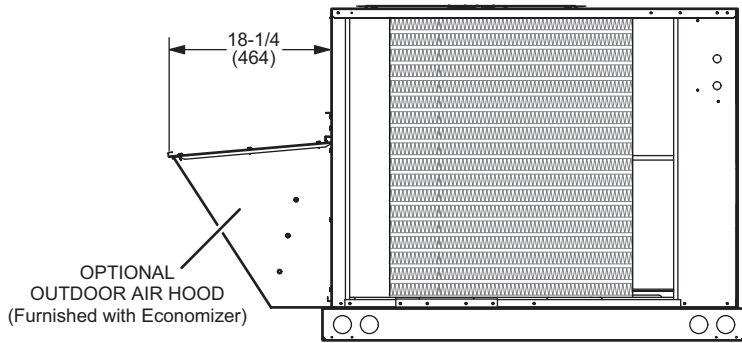

SIDE VIEW

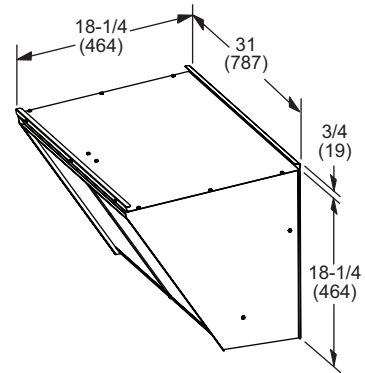

OUTDOOR AIR DAMPER HOOD DETAIL (Downflow or Horizontal Applications)

MANUAL OUTDOOR AIR HOOD

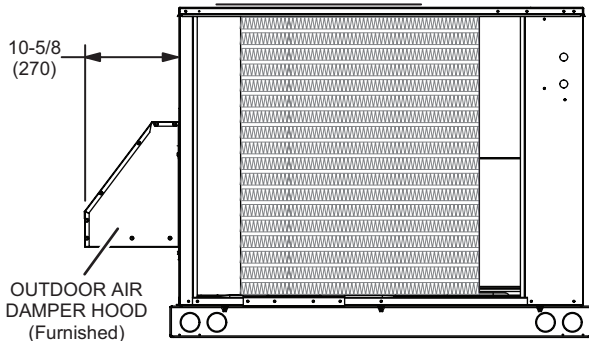

END VIEW

MOTORIZED OUTDOOR AIR HOOD

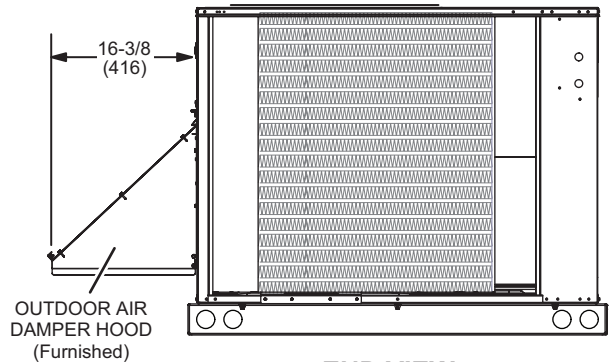

END VIEW

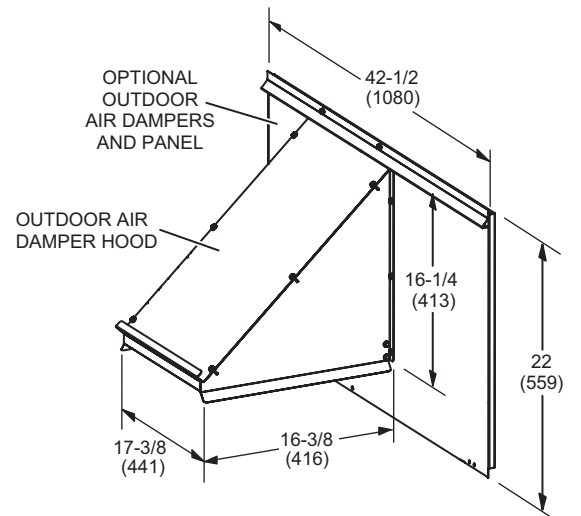
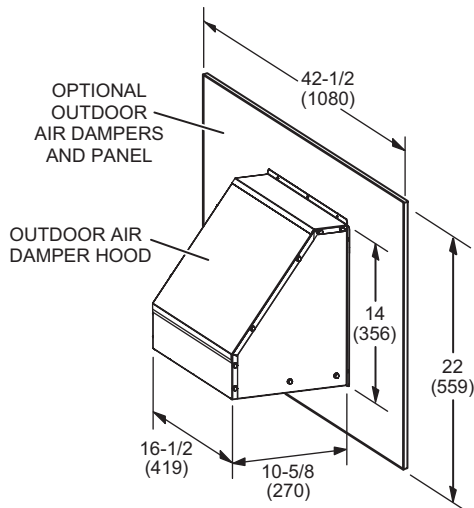

DIMENSIONS - ACCESSORIES

**OUTDOOR AIR HOOD DETAIL WITH OPTIONAL ECONOMIZER AND BAROMETRIC RELIEF DAMPERS
(Horizontal Applications)**

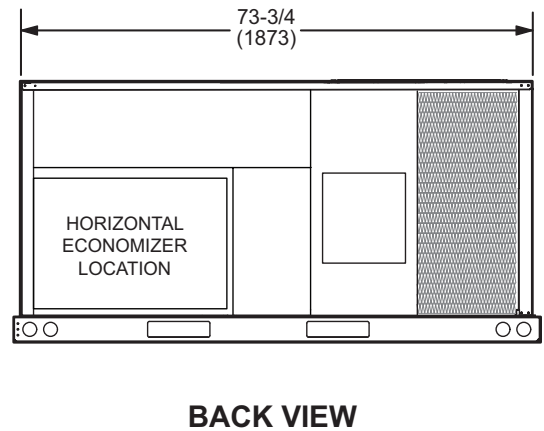
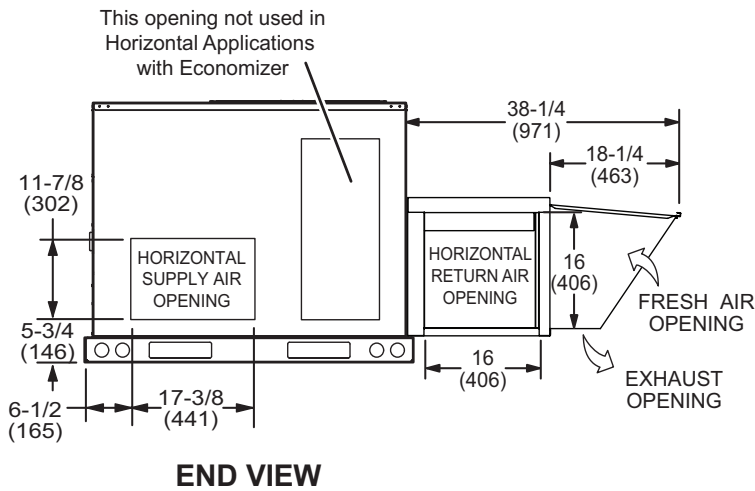
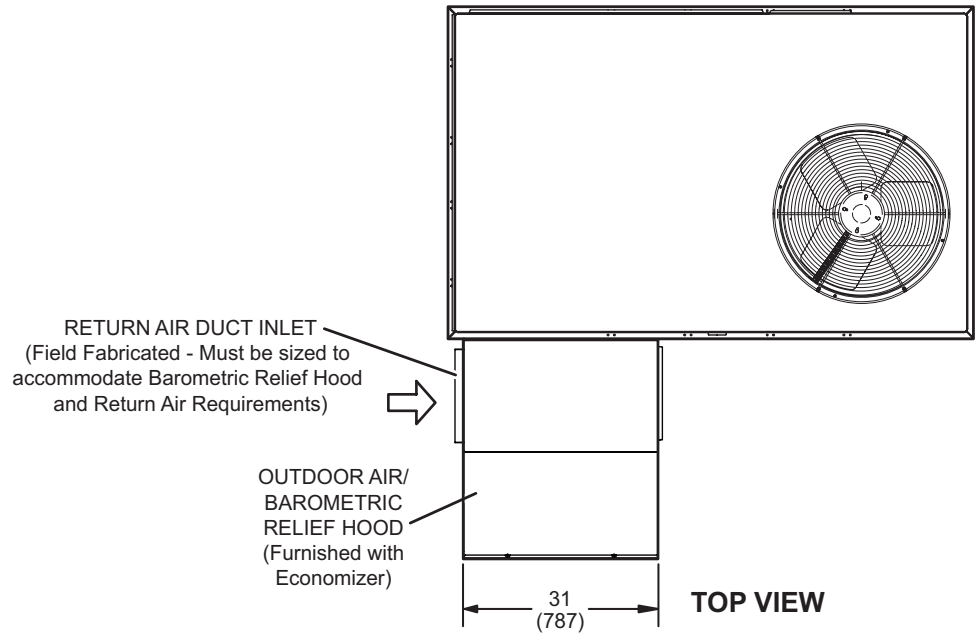

Note - Return Air Duct and Transition must be supported.

DIMENSIONS - ACCESSORIES

HYBRID ROOF CURBS - DOUBLE DUCT OPENING

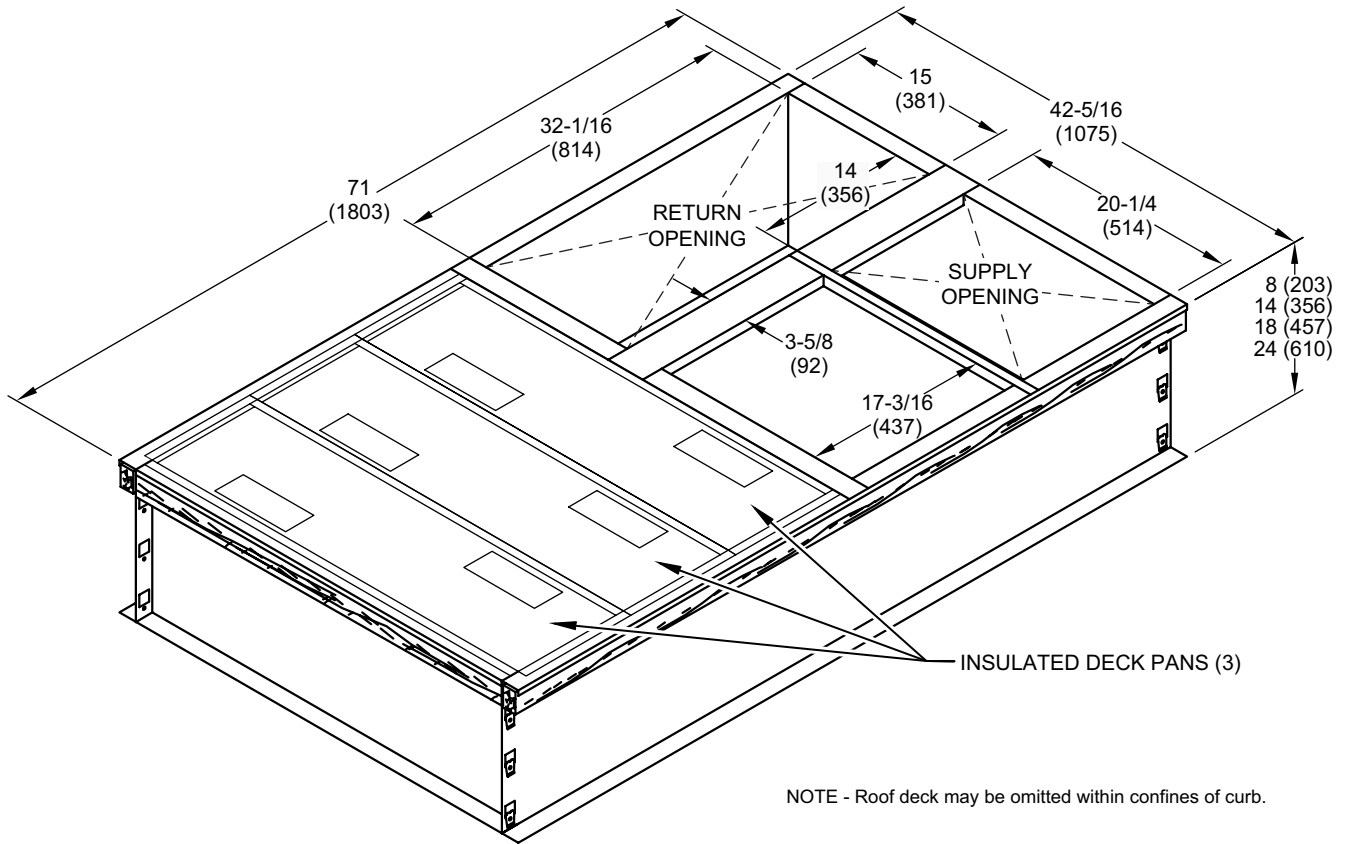

TYPICAL FLASHING DETAIL FOR ROOF CURB

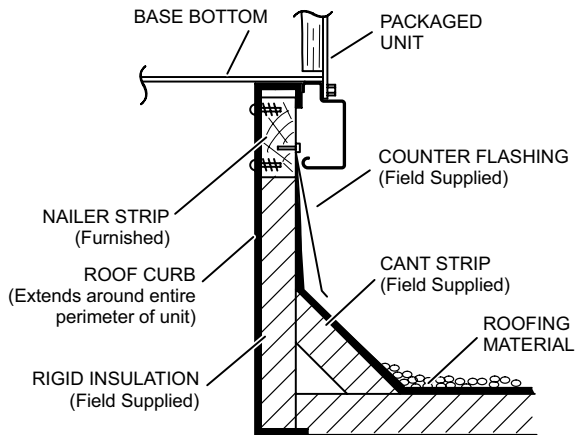

DETAIL ROOF CURB

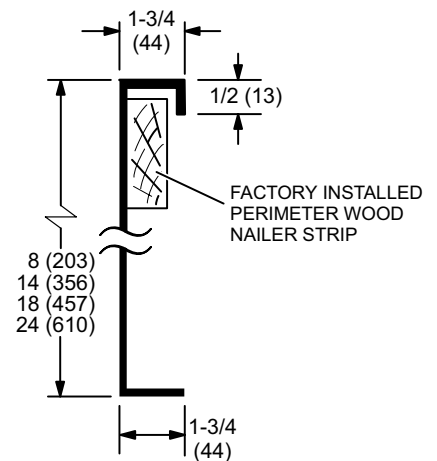

DIMENSIONS - ACCESSORIES

COMBINATION CEILING SUPPLY AND RETURN DIFFUSERS

STEP-DOWN CEILING DIFFUSER

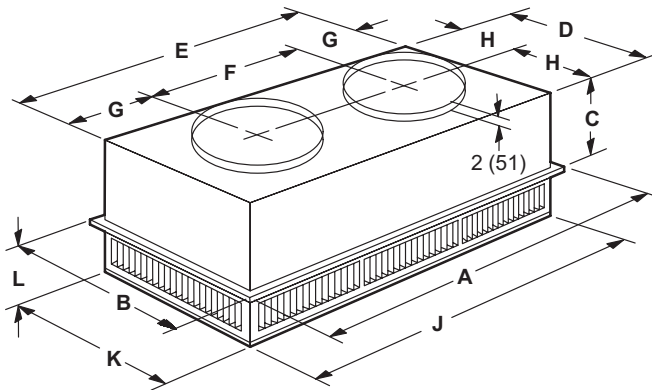

FLUSH CEILING DIFFUSER

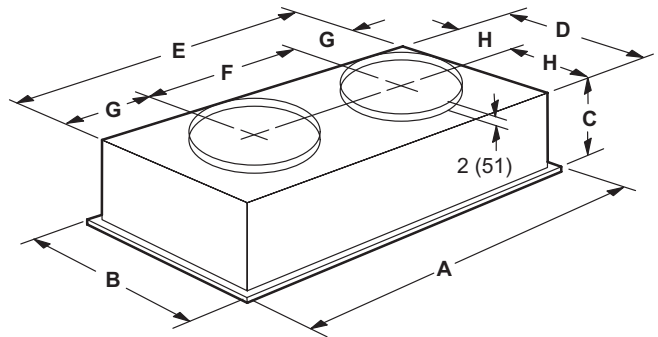

Model Number		RTD9-65S	RTD11-95S
A	in.	47-5/8	47-5/8
	mm	1159	1159
B	in.	23-5/8	29-5/8
	mm	600	752
C	in.	11-3/8	14-3/8
	mm	289	365
D	in.	21-1/2	27-1/2
	mm	546	699
E	in.	45-1/2	45-1/2
	mm	1156	1158
F	in.	22-1/2	22-1/2
	mm	572	572
G	in.	11-1/2	11-1/2
	mm	292	292
H	in.	10-3/4	13-3/4
	mm	273	349
J	in.	45-1/2	45-1/2
	mm	1156	1156
K	in.	21-1/2	27-1/2
	mm	546	699
L	in.	7-1/8	8-1/8
	mm	181	206
Duct Size	in.	18 round	20 round
	mm	457 round	508 round

Model Number		FD9-65S	FD11-95S
A	in.	47-5/8	47-5/8
	mm	1159	1159
B	in.	23-5/8	29-5/8
	mm	600	752
C	in.	13-1/2	16-5/8
	mm	343	422
D	in.	21	27
	mm	533	686
E	in.	45	45
	mm	1143	1143
F	in.	22-1/2	22-1/2
	mm	572	572
G	in.	11-1/4	11-1/4
	mm	286	286
H	in.	10-1/2	13-1/2
	mm	267	343
Duct Size	in.	18 round	20 round
	mm	457 round	508 round

REVISIONS

Sections	Description of Change
Options / Accessories	Added Smoke Detectors, GFI Outlets, and Disconnects as options.
Electrical Accessories - Disconnects	New Section.
Electrical Accessories - Fuse Blocks	New Section.



Visit us at www.Lennox.com

For the latest technical information, www.LennoxCommercial.com

Contact us at 1-800-4-LENNOX

NOTE - Due to Lennox' ongoing commitment to quality, Specifications, Ratings and Dimensions subject to change without notice and without incurring liability. Improper installation, adjustment, alteration, service or maintenance can cause property damage or personal injury. Installation and service must be performed by a qualified installer and servicing agency.

©2026 Lennox Industries, Inc.