

# LGM

## MODEL L™ ROOFTOP UNITS

Ultra-High Efficiency | Lennox® CORE Controller | Environ™ Coil | **R-454B** | 60Hz



COMMERCIAL  
PRODUCT SPECIFICATIONS (EHB)

13 to 25 Tons

Net Cooling Capacity | 150,000 to 270,000 Btuh  
Gas Input Heat Capacity | 85,000 to 480,000 Btuh

# MODEL / L



SMART WIRE™ SYSTEM



### MODEL NUMBER IDENTIFICATION

**L G M 240 U 5 M S 2 Y**

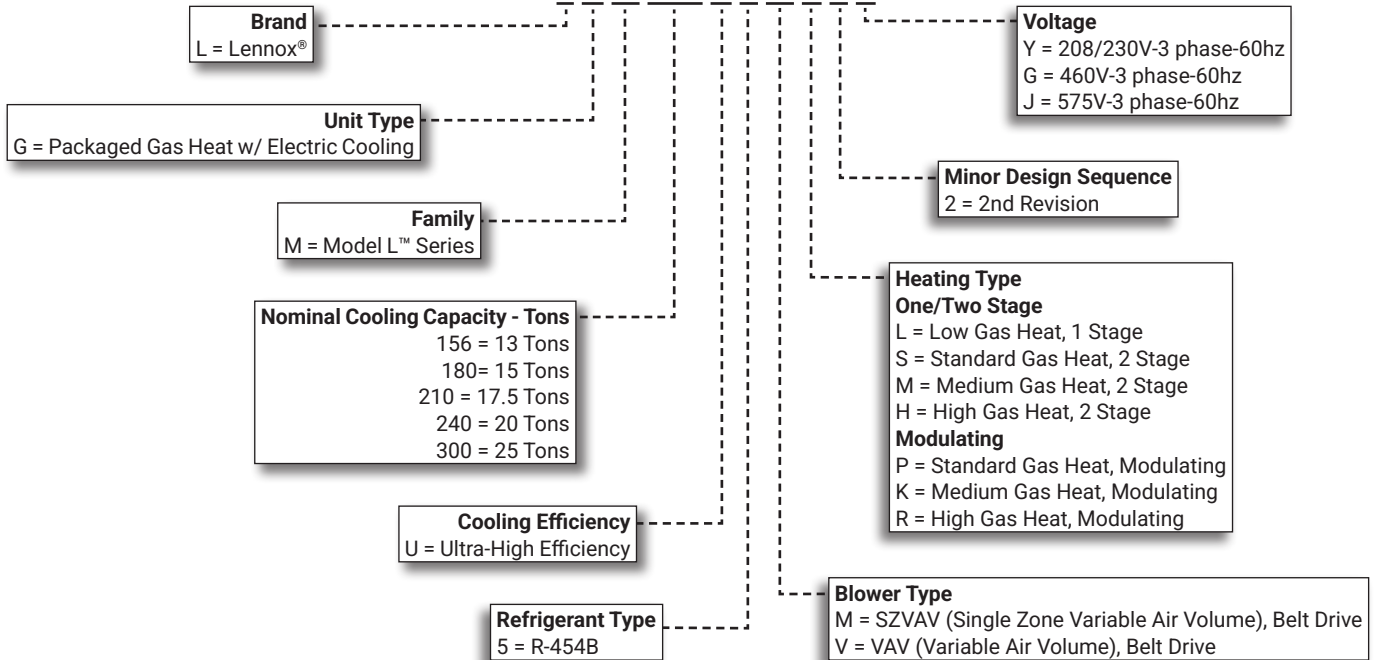

## FEATURE HIGHLIGHTS

The Model L™ packaged rooftop line is engineered with advanced variable speed technology to offer some of the highest energy efficiencies in the industry while delivering superior temperature and humidity control in a wide variety of commercial applications.

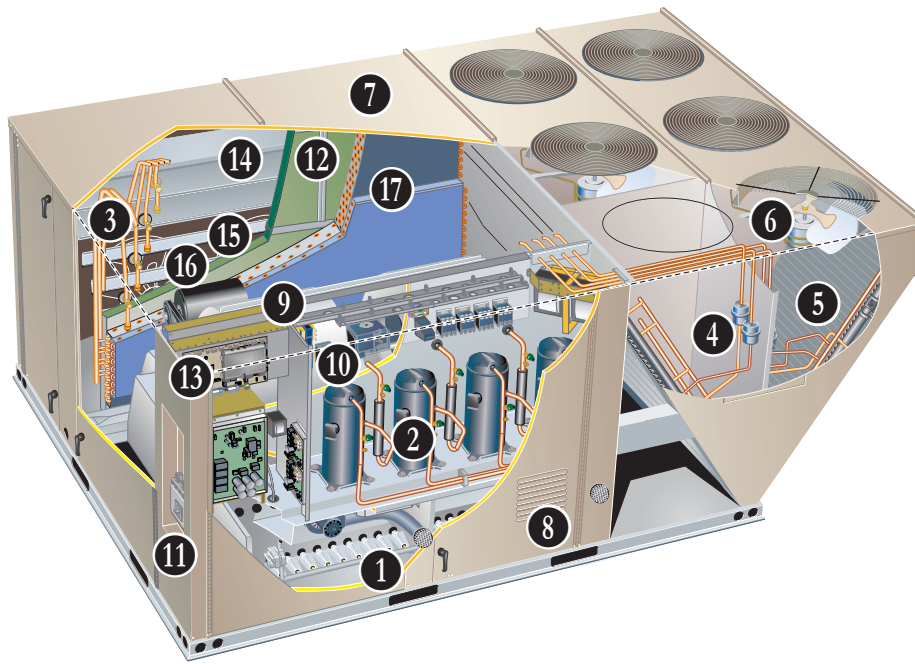

1. Aluminized Steel Inshot Burners
2. Variable Capacity Scroll Compressor (1) and Fixed Capacity Scroll Compressors (2 or 3)
3. Thermal Expansion Valves
4. Filters/Driers
5. Condenser Coil
6. Variable-Speed ECM Outdoor Coil Fan Motors (4) 156-180 and (6) 210-300
7. Heavy-Gauge Steel Cabinet
8. Hinged Access Panels
9. Supply Air Blower
10. Variable-Frequency Drive (VFD)
11. Disconnect Switch (option)
12. Air Filters
13. Lennox® CORE Control System
14. Economizer (option)
15. Downflow Barometric Relief Dampers (option)
16. Power Exhaust Fans (option)
17. Humiditrol™+ Dehumidification System (option)

## CONTENTS

Approvals And Warranty . . . . .	3
Blower Data . . . . .	38
Control System . . . . .	10
Cooling Ratings . . . . .	30
Dimensions . . . . .	47
- Accessories . . . . .	49
- LGM156   LGM180 . . . . .	47
- LGM210   LGM240   LGM300 . . . . .	48
Electrical Data . . . . .	41
- 13 Ton . . . . .	41
- 15 Ton . . . . .	41
- 17.5 Ton . . . . .	42
- 20 Ton . . . . .	42
- 25 Ton . . . . .	43
Features And Benefits . . . . .	3
High Altitude Derate . . . . .	29
Humiditrol™+ Dehumidification System Option . . . . .	14
Humiditrol™+ Dehumidification System Ratings . . . . .	35
Model Number Identification . . . . .	1
Optional Conventional Temperature Control Systems . . . . .	16
Options / Accessories . . . . .	22
Outdoor Sound Data . . . . .	45
Sequence Of Operation . . . . .	18
Specifications . . . . .	26
- 13 Ton . . . . .	26
- 15 Ton   17.5 Ton . . . . .	27
- 20 Ton   25 Ton . . . . .	28
Specifications - Gas Heat . . . . .	29
Weight Data . . . . .	46

## APPROVALS AND WARRANTY

### APPROVALS

- All models are AHRI Standard 340/360-2023 certified
- ENERGY STAR® certified
- ETL and CSA listed
- All models are ASHRAE 90.1-2025 compliant
- All models meet DOE 2023 energy efficiency standards
- All models are listed to UL 60335-1 and UL 60335-2-40 and meet the Refrigerant Detection and Dissipation Requirements
- Components are bonded for grounding to meet safety standards for servicing required by ETL, NEC and CEC
- All models have been sound tested in accordance with test conditions included in AHRI Standard 270 or 370
- ISO 9001 Registered Manufacturing Quality System
- All models meet California Code of Regulations, Title 24 and ASHRAE 90.1-2025 Section 6.4.3.10 requirements for staged airflow
- All models have HCAI (formerly OSHPD) OSP and Special Seismic Certification (Number: [OSP-0596](#)), and meet 2021 International Building Code (IBC), 2022 California Building Code (CBC) ASCE 7, and ICC-ES AC156
- All models have FSA approval and are compliant with standard ASCE 7-22 (ASD) and the Florida Building Code Eighth Edition (2023)
- Units are charged with virgin refrigerant to comply with NYCRR Part 494
- All models are fully charged and run tested to verify unit operation and functionality

### WARRANTY

- Aluminized Steel Heat Exchanger - Limited ten years
- Stainless Steel Heat Exchanger (optional) - Limited fifteen years
- Compressors - Limited five years
- Lennox® CORE Unit Controller - Limited three years
- Variable-Frequency Drive (VFD) - Limited five years
- High Performance Economizers (optional) - Limited five years
- All other covered components - Limited one year

## FEATURES AND BENEFITS

### HEATING SYSTEM

#### 1 Heat Exchanger

- Tubular construction, aluminized steel
- Life-cycle tested

**NOTE** - Optional Stainless Steel Heat Exchanger is required if mixed air temperature is below 45°F.

- Aluminized steel inshot burners
- Direct spark ignition
- Electronic flame sensor
- Combustion air inducer
- Redundant automatic gas valves with manual shut-off

#### Electronic Pilot Ignition

- Electronic spark igniter provides positive direct ignition of burners on each operating cycle
- Permits main gas valve to stay open only when the burners are proven to be lit
- If loss of flame occurs, gas valve closes, shutting off the gas to the burners
- LED indicates status and aids in troubleshooting
- Watchguard circuit on module automatically resets ignition controls after one hour of continuous thermostat demand after unit lockout, eliminating nuisance service calls

- Factory installed in the gas heating compartment

#### Limit Controls

- Redundant limit controls with fixed temperature setting
- Protects heat exchanger and other components from overheating

#### Safety Switches

- Flame roll-out switch
- Flame sensor
- Combustion air inducer proving switch
- Protects system operation

#### One-Stage Gas Heat (156-210 Models)

- Single stage gas valve heating output

#### Two-Stage Gas Heat (240-300)

- Two-Stage gas valve adjusts heat for low and high output

**NOTE** – One-Stage Gas Heat is standard with 156-210 models.

Two-Stage Gas Heat is standard with 240-300 models.

Two-Stage Gas Heat can be ordered as an option for 156-210 models.

**NOTE** – Modulating Gas Heat may be ordered as a factory installed option. See Options/Accessories table.

## FEATURES AND BENEFITS

### HEATING SYSTEM (continued)

#### Required Selections

##### Gas Input Choice - Order one:

- Low Gas Heat - 1 Stage (156-210 models) - 169,000 Btuh
- Standard Gas Heat - 2 Stages or Modulating (all models) - 169,000-260,000 Btuh
- Medium Gas Heat - 2 Stages or Modulating (all models) - 234,000-360,000 Btuh
- High Gas Heat - 2 Stages or Modulating (180-300 models) - 312,000-480,000 Btuh

**NOTE** – Two-stage heat models can be operated with four stages of gas heating when controlled in either room sensor, Discharge Air Control, or fresh air tempering mode on the Lennox® CORE Unit Controller. See Gas Heating Specifications table.

#### Options/Accessories

##### Factory Installed

##### Two-Stage Gas Heat (156-180 Models)

- Two-Stage gas valve adjusts heat for low and high output

##### Modulating Gas Heat

- Modulating gas valve adjusts heat output in real time based on demand for smoother temperature control
- Includes two factory-installed sensors:
  - Mixed Air Sensor
  - Indirect Sensing Discharge Air Temperature Sensor

**NOTE** - Modulating Gas Heat for Horizontal Applications requires a Remote Discharge Air Temperature Sensor / Fresh Air Tempering. Sensor is shipped with the unit for field installation if unit is configured at the factory. Sensor must be ordered separately for field installation if unit is not factory configured.

##### Stainless Steel Heat Exchanger

- Required if mixed air temperature is below 45°F

##### Field Installed

##### Bottom Gas Piping Kit

- Allows bottom gas entry

#### Options/Accessories

##### Field Installed

##### Combustion Air Intake Extensions

- Recommended for use with existing flue extension kits in areas where high snow can block intake air
- Order two kits

##### Low Temperature Vestibule Heater

- Electric heater automatically controls minimum temperature in gas burner compartment when temperature is below -40°F
- CSA certified to allow operation of unit down to -60°F

##### LPG/Propane Kits

- Conversion kit to field change over units from Natural Gas to LPG/Propane
- Order two kits

##### Vertical Vent Extension Kit

- Use to exhaust flue gases vertically above unit
- Required when unit vent is too close to fresh air intakes per building codes
- Also prevents ice formation on intake louvers
- Kit contains vent transition, vent tee, drain cap and installation hardware

**NOTE** - Straight vent pipes (4 in. B-Vent) and caps are not furnished and must be field supplied. Refer to kit instructions for additional information.

### COOLING SYSTEM

- Designed to maximize sensible and latent cooling performance at design conditions
- System can operate from 0°F to 125°F without any additional controls

##### R-454B Refrigerant

- Low GWP (Global Warming Potential)
- Zero ODP (Ozone Depletion Potential)
- Low Toxicity/Lower Flammability - A2L
- Unit is factory pre-charged

## 2 Multiple Compressors

Cooling system consists of one variable capacity scroll compressor and multiple fixed capacity scroll compressors (two for 156-180 models, three for 210-300 models)

##### Variable Capacity Scroll Compressor

- High performance, reliability and quiet operation
- Operates on a variable-frequency determined to vary capacity based on the cooling load required

##### Fixed Capacity Scroll Compressors

- High performance, reliability and quiet operation
- Resiliently mounted on rubber grommets for quiet operation

##### DC Inverter Control (for Variable Capacity Compressor)

- Converts AC line voltage into filtered variable DC voltage
- Provides continuous compressor operation, while adjusting the capacity according to discharge air temperature
- Adjusts compressor output in increments as small as 1%
- Prevents frequent changes in capacity and ensures efficient, economical operation
- Power Factor Correction (PFC) circuit monitors the DC bus for high, low and abnormal voltage conditions to protect the compressor
- Two LEDs (red and green) indicate inverter operating status and aid in troubleshooting
- Noise filter reduces unwanted electromagnetic interference (EMI)
-

## FEATURES AND BENEFITS

### **COOLING SYSTEM (continued)**

- Inverter reactor adds inductance to the line between the inverter and the compressor to limit current rise and protect the compressor

#### **Compressor Crankcase Heaters**

- Protects against refrigerant migration that can occur during low ambient operation or during extended off cycles

### **3 Thermal Expansion Valves**

- Ensures optimal performance throughout the application range
- Removable element head

### **4 Filter/Driers**

- High capacity filter/drier protects the system from dirt and moisture

#### **High Pressure Switches**

- Protects the compressors from overload conditions such as dirty condenser coils, blocked refrigerant flow, or loss of outdoor fan operation

#### **Low Pressure Switches**

- Protects the compressors from low pressure conditions such as low refrigerant charge or low/no airflow

#### **Diagnostic and Sensor System**

- Multiple thermistors continuously monitor the refrigeration system, providing optimum performance and complete circuit protection at all operating conditions

#### **Indoor Coil Freeze Protection**

- Protects the evaporator coil from damaging ice build-up due to conditions such as low/no airflow or low refrigerant charge

### **5 Condenser Coil - Environ™ Coil System**

- Lightweight, all aluminum brazed fin construction
- Constructed of three components
  - A flat extrusion tube
  - Fins in-between the flat extrusion tube
  - Two refrigerant manifolds

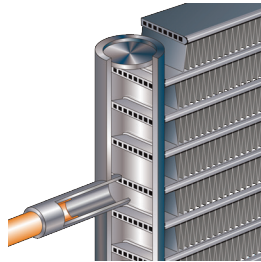

#### **Environ™ Coil System Features:**

- Improved heat transfer performance due to high primary surface area (flat tubes) versus secondary surface (fins)
- Smaller internal volume (reduced refrigerant charge)
- High durability
- All aluminum construction
- Fewer brazed joints
- Compact design
- Reduced unit weight
- Easy maintenance/cleaning
- Mounting brackets with rubber inserts secure coil to unit providing vibration dampening and corrosion protection

#### **Evaporator Coil**

- Copper tube construction
- Enhanced rippled-edge aluminum fins

- Flared shoulder tubing connections
- Silver soldered construction for improved heat transfer
- Factory leak tested
- Cross-row circuiting with rifled tubing optimizes both sensible and latent cooling capacity

#### **Anti-Microbial Condensate Drain Pan**

- Plastic pan, sloped to meet drainage requirements per ASHRAE 62.1
- Anti-Microbial additive resists growth of mold and mildew on drain pan, which improves indoor air quality and reduces drain line blockage
- Side or bottom drain connections

### **6 Variable-Speed ECM Outdoor Coil Fan Motors**

- Fan speed is directly controlled by the Lennox® CORE Unit Controller
- Thermal overload protected
- Totally enclosed
- Permanently lubricated ball bearings
- Shaft up
- Wire basket mount

#### **Outdoor Coil Fans**

- PVC coated fan guards furnished

### **Required Selections**

#### **Cooling Capacity**

- Specify nominal cooling capacity

### **Options/Accessories**

#### **Factory or Field Installed**

##### **Drain Pan Overflow Switch**

- Monitors condensate level in drain pan
- Shuts down unit if drain becomes clogged

##### **Field Installed**

##### **Condensate Drain Trap**

- Available in copper or PVC

### **LOW GWP REFRIGERANT DETECTION SYSTEM (RDS)**

- Complies with UL 60335-2-40 approved standard
- Required for all systems using R-454B refrigerant
- Factory installed on all units
- Consists of a refrigerant detection sensor(s) and a mitigation control
- Ensures safe operation for systems equipped with R-454B refrigerant
- Sensor(s) monitors indoor coil area for R-454B refrigerant
- If R-454B refrigerant is detected the refrigerant detection system will prevent compressor and heating operation until R-454B refrigerant is no longer detected
- Refrigeration detection system energizes blower if any R-454B refrigerant is detected to mitigate any concentrations of refrigerant from the unit and the system

## FEATURES AND BENEFITS

### **CABINET**

#### **7** Construction

- Heavy-gauge steel panels
- Full perimeter heavy-gauge galvanized steel base rail
- Base rails have rigging holes
- Three sides of the base rail have forklift slots
- Raised edges around duct and power entry openings in the bottom of the unit for water protection

#### Airflow Choice

- Units are shipped in downflow (vertical) configuration

**NOTE** - Units can be field converted to horizontal air flow with optional Horizontal Return Air Panel Kit and Horizontal Roof Curb.

#### Power/Gas Entry

- Electrical and gas lines can be routed through the unit base or through horizontal access knock-outs

#### Exterior Panels

- Constructed of heavy-gauge, galvanized steel
- Textured pre-paint with polyurethane finish
- Cyclic salt fog and UV exposure up to 1680 hours per ASTM D5894

#### Insulation

- Fully insulated with non-hygroscopic fiberglass insulation (conditioned areas)
- Unit base is fully insulated
- Base insulation serves as an air seal to the roof curb, eliminating the need to add a seal during installation

#### **8** Hinged Access Panels

- Filter section
- Blower section
- Heating section
- Compressor/controls section
- Panel seals and quarter-turn latching handles provide a tight air and water seal

### Required Selections

#### Airflow Configuration

- Specify downflow or horizontal

### Options/Accessories

#### **Factory Installed**

##### Corrosion Protection

- Completely flexible immersed coating
- Electrodeposited dry film process (AST ElectroFin E-Coat)
- ASTM B117 / DIN 53167 Salt Spray - 15,000+ hours
- ASTM G85 Annex A3 SWAAT Modified Salt Spray - 3000 hours
- VA Master Construction Specification Division 23 for High Humidity Installations
- CID AA-52474A (GSA)
- Indoor Corrosion Protection:
  - Coated coil
  - Coated reheat coil (Humiditrol™+)
  - Painted blower housing
  - Painted indoor base
- Outdoor Corrosion Protection:
  - Coated coil
  - Painted outdoor base

#### **Factory or Field Installed**

##### Combination Coil/Hail Guards

- Heavy gauge steel frame
- Painted to match cabinet
- Expanded metal mesh protects outdoor coil

#### **Field Installed**

##### Horizontal Return Air Panel Kit

- Required for horizontal applications with Horizontal Roof Curb
- Contains panel with return air opening for field replacement of existing unit panel and panel to cover bottom return air opening in unit
- See dimension drawings

##### Burglar Bars

- Heavy gauge galvanized frame
- Fully welded
- 3/4 in. bar meets ASTM specification
- Frame meets ASTM A446, A525, A526 and A527 specification
- Burglar bars designed to fit ductwork

## FEATURES AND BENEFITS

### **BLOWER**

A wide selection of supply air blower options are available to meet a variety of airflow requirements

#### **Motor**

- Overload protected, equipped with ball bearings
- Belt drive motors are offered on all models and are available in several different sizes to maximize air performance

#### **Motor Efficiency**

- All blower motors 5 HP and above meet minimum energy efficiency standards in accordance with the Energy Independence and Security Act (EISA) of 2007

### **9 Supply Air Blower**

- Forward curved blades
- Double inlet
- Blower wheel is statically and dynamically balanced
- Ball bearings
- Adjustable pulley (allows speed change)
- Blower assembly slides out of unit for servicing
- Grease fittings furnished

#### **Blower Proving Switch**

- Monitors blower operation, shuts down unit if blower fails

#### **Supply Static Pressure Transducer (VAV Models Only)**

- Sends information to the Lennox® CORE Unit Controller to control VFD blower speed
- Shipped with the unit for remote field installation in the supply duct

### **Required Selections**

#### **Select SZVAV (Single Zone Variable Air Volume) or Variable Air Volume (VAV) Models**

- SZVAV (Single Zone Variable Air Volume) modulates the amount of airflow according to cooling demand, heating demand, ventilation demand or smoke alarm
  - Variable Air Volume (VAV) modulates the air volume to maintain a constant duct static pressure
- 10**
- Utilizes a Variable-Frequency Drive (VFD) to modulate the supply blower airflow
    - VFD alters the frequency and voltage of the power supply to the blower to control blower speed
    - The amount of airflow for each stage can be set according to a parameter in the Lennox® CORE unit controller
    - Unit is shipped from the factory with preset airflows
    - SZVAV can be ordered with or without an Electronic Bypass Control
    - If equipped with the bypass control the SZVAV features manual (default) or automatic electronic bypass control of the VFD
    - In case of a VFD malfunction, a VFD alarm is generated by the Lennox® CORE unit controller

- VFD can be manually bypassed to continue unit operation at full blower speed or the unit controller can be set to automatically switch to full blower speed if a VFD alarm is generated
- VFD has an operational range of -40 to 125°F outdoor air ambient temperature
- Lower operating costs are obtained when the blower is operated on lower speeds

**NOTE** - Variable-Frequency Drive (VFD) is designed to operate on balanced, three-phase power. Operating units on unbalanced three-phase power will reduce the reliability of all electrical components in the unit. Unbalanced power is a result of the power delivery system supplied by the local utility company. Factory-installed inverters are sized to drive blower motors with an equivalent current rating using balanced three-phase power. If unbalanced three-phase power is supplied; the installer must replace the existing factory-installed inverter with an inverter that has a higher current rating to allow for the imbalance. Refer to the installation instructions for additional information and replacement information

#### **Ordering Information**

- Specify motor horsepower and drive kit number when base unit is ordered

### **Options/Accessories**

#### **Field Installed**

##### **Blower Belt Auto-Tensioner**

- Provides proper tension to belt drive blower belt without the need for regular adjustments
- Maintains airflow and proper performance

## FEATURES AND BENEFITS

### **ELECTRICAL**

#### **SmartWire™ System**

- Advanced wiring connectors are keyed and color-coded to prevent miswiring
- Wire coloring scheme is standardized across all models
- Each connection is intuitively labeled to make troubleshooting and servicing quick and easy

#### **Electrical Plugs**

- Positive connection electrical plugs connect common accessories or maintenance parts for easy removal or installation

#### **Phase/Voltage Detection Phase**

- Monitors power supply to ensure phase is correct at unit start-up
- If phase is incorrect, the unit will not start and an alarm code is reported to the unit controller
- Protects unit from being started with incorrect phasing which could lead to issues such as compressors running backwards
- Voltage detection monitors power supply voltage to ensure proper voltage
- If voltage is not correct (over/under voltage conditions) the unit will not start and an alarm code is reported to the unit controller

### **Required Selections**

#### **Voltage Choice**

- Specify when ordering base unit

### **Options/Accessories**

#### **Factory Installed**

##### **Circuit Breakers**

- HACR type
- For overload and short circuit protection
- Factory wired and mounted in the power entry panel
- Current sensitive and temperature activated
- Manual reset

##### **Short-Circuit Current Rating (SCCR)**

- Higher short circuit protection up to 100kA

**NOTE** - Disconnect Switch is furnished and factory installed with High SCCR option.

#### **Factory or Field Installed**

##### **11 Disconnect Switch**

- Accessible from outside of unit
- Spring loaded weatherproof cover furnished

##### **GFI Service Outlets (2)**

- 115V ground fault circuit interrupter (GFCI) type
- Available non-powered, field-wired or factory-wired and powered

#### **Field Installed**

##### **GFI Weatherproof Cover**

- Single-gang cover
- Heavy-duty UV-resistant polycarbonate case construction
- Hinged base cover with gasket

## FEATURES AND BENEFITS

### INDOOR AIR QUALITY

12

#### Air Filters

- Disposable 2 inch MERV 4 filters furnished as standard

#### Options/Accessories

#### Factory or Field Installed

##### Healthy Climate® High Efficiency Air Filters

- Disposable MERV 8, MERV 13 or MERV 16 (Minimum Efficiency Reporting Value based on ASHRAE 52.2) efficiency 2-inch pleated filters

#### Field Installed

##### Healthy Climate® UVC Germicidal Lamps

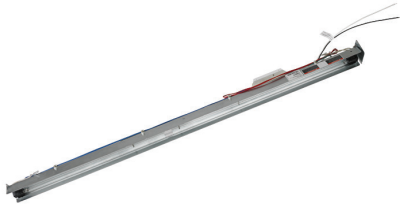

- Germicidal lamps emit ultra-violet (UV-C) energy, which has been proven to be effective in reducing microbes such as viruses, bacteria, yeasts, and molds
- This process either destroys the organism or controls its ability to reproduce
- UV-C energy greatly reduces the growth and proliferation of mold and other bioaerosols (bacteria and viruses) on illuminated surfaces (particularly coil and drain pan)
- Installed in the blower/evaporator coil section
- Safety interlock switch automatically shuts off power to the UVC light when panel is removed
- Interlock switch is factory installed or field installed in the blower/evaporator coil section panel
- All necessary hardware for installation is included
- Lamps operate on 110/230V, 1 phase power supply

**NOTE** - Step-down transformer may be ordered for field installed UVC lamps when used with 460V and 575V rooftop units. Step-down transformer is furnished with lamps when factory installed.

- Approved by ETL

##### Needlepoint Bipolar Ionization (NPBI) Kit

- NPBI technology integrates with system controls for effective air treatment
- Ionization has been shown to effectively reduce harmful pathogens, pollutants and odors

**NOTE** - Please visit [www.sciencedirect.com](http://www.sciencedirect.com) for additional information.

- Brush-type ionizer introduces a high concentration of both positive and negative ions into the airstream
- These bipolar ions are then dispersed into the occupied space through the duct system proactively reducing the airborne contaminants
- Ions travel within the building air stream and attach to particles, pathogens, and gas molecules, making them larger and easier to capture in the filtration system
- UL 2998 certified for zero ozone emission

##### Indoor Air Quality (CO<sub>2</sub>) Sensors

- Monitors CO<sub>2</sub> levels, reports to the Lennox® CORE Unit Controller which adjusts Economizer dampers as needed

##### Replacement Filter Media Kit With Frame

- Replaces existing pleated filter media
- Includes washable metal mesh screen and metal frame with clip for holding replaceable non-pleated filter

## CONTROL SYSTEM

### LENNOX® CORE CONTROL SYSTEM

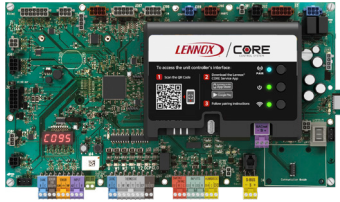

The Lennox® CORE Control System is designed to accelerate equipment install and service. Standard with all Model L™ rooftop units, control system integrates key technologies that lower installation costs, drive system efficiency, and protect your investments.

- 13** The Lennox® CORE Unit Controller is a microprocessor-based controller that provides flexible control of all unit functions.

#### CORE Mobile Service App

- Guided Setup with progress indicators, detailed help, and exportable summaries to manage simple, trouble-free setup, reducing commissioning times
- Enhanced Test Functionality provides real-time sensor readings, trending, and reports that enable easy troubleshooting
- Ability to set and configure parameters of the CORE Control System to manage sequence of operation
- Economizer test function ensures economizer is operating correctly



#### Additional Features:

- Built-In 7-Segment Display shows Unit Status and active alarms for easy troubleshooting
- Buttons for test and clearing delays
- SmartWire™ System with keyed and removable screw terminals ensure correct field wiring
- Built-in BACnet MS/TP and IP allow open integration to building management systems.
- Two-port Ethernet Switch enables daisy chaining for BACnet IP and automatic firmware updates

**NOTE** - Unit Internet Connection required.

- Profile setup copies key settings between units with the same configuration to reduce setup time
- USB port allows a technician to download and transfer unit information to help verify service was performed
- USB software updates on the Lennox® CORE Unit Controller enhance functionality without the need to change components
- Unit Controller Software

#### Configurable Built-In Functions

- Full modulation of variable speed compressor for discharge air temperature control in room sensor or thermostat mode
- Discharge Air Cooling Control
- Up to 3 distinct Cooling Airflows in Thermostat Mode

- Programmable independent heating, ventilation and cooling blower speeds
- Discharge Air Heating Control
- Economizer Control Options (See Economizer / Exhaust Air / Outdoor Air sections)
- Exhaust Fan Control Modes for fresh air damper position
- Configurable Morning Warm-up
- Night Setback Mode
- Fresh Air Tempering for Improved Ventilation
- Demand Control Ventilation
- Low Ambient Controls for operation down to 0°F
- Humiditrol™+ Operation
- Enhanced Dehumidification (Latent Demand Control without reheat)

#### Component Protection / Unit Safeguards:

- Compressor Time-Off Delay
- Adjustable Blower On/Off Delay
- Return Air Temperature Limit Control
- Safety Switch Input allows Controller to respond to a external safety switch trip
- Service Relay Output
- Thermostat Bounce Delay
- Smoke Alarm Mode has four choices (unit off, positive pressure, negative pressure, purge)
- "Strike Three" Protection
- Gas Valve Time Delay Between First and Second Stage
- Minimum Compressor Run Time

#### Control Methods / Interfaces:

- DDC and 24V Thermostat
- BACnet MS/TP and IP
- LONTalk (Factory and Field Option)
- Lennox SBUS
- Zone Temperature Sensor Input
- Dehumidistat and Humidity Sensor Inputs
- Indoor Air Quality Inputs (2)
- Built-in Control Parameter Defaults
- Permanent Diagnostic Code Storage
- Field Adjustable Control Parameters (Over 200 settings)
- Multiple Configurable Digital Inputs
- LED Indicators
- PC Interface connects the Lennox® CORE Unit Controller to a PC with the Lennox Unit Controller Software

**NOTE** - Lennox® CORE Control System features vary with the type of rooftop unit in which the control is installed.

## CONTROL SYSTEM

### LENNOX® CORE CONTROL SYSTEM (continued)

#### Control Options

#### Factory or Field Installed

##### Dirty Filter Switch

- Senses static pressure increase and issues alarm if necessary

##### Fresh Air Tempering

- Used in applications with high outside air requirements
- Controller energizes the first stage heat as needed to maintain a minimum supply air temperature for comfort, regardless of the thermostat demand
- When ordered as a factory option, sensor ships with the unit for field installation

##### Smoke Detector

- Photoelectric type
- Installed in supply air section, return air section or both sections
- Available with power board and single sensor (supply or return) or power board and two sensors (supply and return)
- Power board located in unit control compartment

### COMMERCIAL CONTROL SYSTEMS

#### Interoperability via BACnet® or LonTalk® Protocols

- Communication compatible with third-party automation systems that support the BACnet Application Specific Controller device profile, LonMark® Space Comfort Controller functional profile, or LonMark Discharge Air Controller functional profile

#### Field Installed

##### Thermostats and Room Sensors

- Control system and thermostat options, see page 16

## OPTIONS / ACCESSORIES

### ECONOMIZER

- Economizer operation is set and controlled by the Lennox® CORE Unit Controller
- Simple plug-in connections from Economizer to unit controller for easy installation
- All Model L™ rooftop units are equipped with factory installed CEC Title 24 approved sensors for outside, return and discharge air temperature monitoring

**NOTE** - Optional sensors may be used instead of unit sensors to determine whether outdoor air is suitable for free cooling. See Options/Accessories table.

#### Factory or Field Installed

#### 14 High Performance Economizer

- Approved for California Title 24 building standards
- Low leakage dampers are Air Movement and Control Association International (AMCA) Class 1A Certified - Maximum 3 CFM per sq. ft. leakage at 1 in. w.g.
- ASHRAE 90.1 and IECC compliant
- Downflow or Horizontal with Outdoor Air Hood
- Outdoor Air Hood with mist elimination is included when Economizer is factory installed and is furnished with Economizer when ordered for field installation

**NOTE** - Downflow or horizontal economizer applications require optional Downflow or Horizontal Barometric Relief Dampers with Exhaust Hood.

- Linked damper action
- High torque 24-volt fully-modulating spring return damper motor
- Return air and outdoor air dampers
- Plug-in connections to unit

**NOTE** - High Performance Economizers are not approved for use with enthalpy controls in Title 24 applications.

**NOTE** - The Free Cooling setpoint for Title 24 applications must be set based on the Climate Zone where the system is installed. See Section 140.4 "Prescriptive Requirements for Space Conditioning Systems" of the California Energy Commission's 2022 Building Energy Efficiency Standards.

**NOTE** - Refer to Installation Instructions for complete setup information.

#### Differential Sensible Control

- Factory setting
- Uses outdoor air and return air sensors that are furnished with the unit
- The Lennox® CORE Unit Controller compares outdoor air temperature with return air
- When the outdoor air is below the configured setpoint and cooler than return air, the controller activates the Economizer

## OPTIONS / ACCESSORIES

### ECONOMIZER (continued)

#### Factory or Field Installed (continued)

**NOTE** - Differential Sensible Control can be configured in the field to provide Offset Differential Sensible Control or Single Sensible Control.

**NOTE** - In Offset Differential Sensible Control mode, the Economizer is enabled if the temperature differential (offset) between outdoor air and return air reaches the configured setpoint. In Single Sensible Control mode, the Economizer is enabled when outdoor air temperature falls below the configured setpoint.

#### Global Control

- The unit controller communicates with a DDC system with one global sensor (enthalpy or sensible)
- Determines whether outside air is suitable for free cooling on all units connected to the control system
- Sensor must be field provided

#### Single Enthalpy Temperature Control (Not for Title 24)

- Outdoor air enthalpy sensor enables Economizer if the outdoor enthalpy is less than the setpoint of the control

#### Differential Enthalpy Control (Not for Title 24)

- Order two Single Enthalpy Controls
- One is field installed in the return air section
- One is installed in the outdoor air section
- Allows the Economizer control to select between outdoor air or return air, whichever has lower enthalpy

#### Field Installed

##### Outdoor Air CFM Control

- Maintains constant outdoor air volume levels on the supply air fan and varying unit airflows
- Velocity sensor located in the rooftop unit outdoor air section, the Lennox® CORE Unit Controller changes the Economizer position to help minimize the effect of supply fan speed changes on outdoor air volume levels
- Setpoint for outdoor air volume is established by field testing

**NOTE** - Not available with Demand Control Ventilation (CO<sub>2</sub> Sensor) or Building Pressure Control.

##### Building Pressure Control

- Maintains constant building pressure level
- Includes a static pressure transducer and outdoor static pressure assembly
- Using differential pressure information between the outdoor air and the building air, the Lennox® CORE Unit Controller changes the Economizer position to help maintain a constant building pressure

**NOTE** - Not available with Demand Control Ventilation (CO<sub>2</sub> Sensor) or Outdoor Air CFM Control.

### EXHAUST

#### Factory or Field Installed

##### **15** Downflow Barometric Relief Dampers

- Allow relief of excess air
- Aluminum blade dampers prevent blow back and outdoor air infiltration during off cycle
- Exhaust hood is factory installed when dampers are factory installed with Economizer
- Exhaust hood is furnished with dampers when ordered for field installation
- Bird screen furnished

##### **16** Power Exhaust Fans

- Install internal to unit for downflow applications only with Economizer option
- Provides exhaust air pressure relief
- Interlocked to run when supply air blower is operating
- Fans run when outdoor air dampers are 50% open (adjustable)
- Motor is overload protected
- Dual propeller type fans are 20 in. diameter
- Five blades
- Two 1/3 HP motors
- SCCR rated

**NOTE** - Requires Economizer with furnished Outdoor Air Hood and Downflow Barometric Relief Dampers.

**NOTE** - SZVAV (Single Zone Variable Air Volume) and VAV (Variable Air Volume) models are equipped with 2-stage power exhaust fans. Power exhaust operates in 1st stage (one fan) up to 70% of supply air blower speed. Both exhaust fans operate in 2nd stage when supply air blower speed is above 70% (adjustable) of full speed.

#### Field Installed

##### Horizontal Barometric Relief Dampers

- For use when unit is configured for horizontal applications requiring an Economizer
- Allows relief of excess air
- Aluminum blade dampers prevent blow back and outdoor air infiltration during off cycle
- Field installed in return air duct
- Bird screen and hood furnished

## OPTIONS / ACCESSORIES

### **OUTDOOR AIR**

#### **Factory or Field Installed**

##### **Motorized Outdoor Air Dampers**

- Linked mechanical dampers
- Fully modulating spring return damper motor with plug-in connection
- 0 to 25% (fixed) outdoor air adjustable
- Installs in unit
- Outdoor air hood with bird screen included

**NOTE** - Outdoor Air Hood is shipped separately in the unit with factory installed dampers for field installation.

#### **Field Installed**

##### **Manual Outdoor Air Damper**

- Adjustable slide damper
- Installed in unit
- Outdoor air hood with bird screen included

### **ROOF CURBS**

#### **Field Installed**

- Nailer strip furnished (downflow only)
- Mates to unit
- US National Roofing Contractors Approved
- Shipped knocked down

#### **Downflow**

##### **Hybrid Roof Curbs**

- Interlocking tabs fasten corners together
- No tools required
- Can also be fastened together with furnished hardware
- Available in 8, 14, 18, and 24 inch heights

##### **Adjustable Pitch Curb**

- Fully adjustable pitch curbs (3/4 in. per foot in any direction) provide a level platform for rooftop units allowing flexible installations on roofs with uneven or sloped angles
- Interlocking tabs fasten corners together
- No tools required
- Hardware is furnished to connect upper curb with lower curb
- Available in 14 inch height

#### **Horizontal**

- Meet National Roofing Code requirements
- Converts unit from downflow to horizontal (side) air flow
- Return air is on unit, supply air is on curb
- See dimension drawings
- Available in 26, 30, 37 and 41 inch heights

**NOTE** - Requires Horizontal Return Air Panel Kit.

**NOTE** - Optional Insulation Kit is available to help prevent sweating.

### **Adaptor Curbs (not shown)**

- Curbs are regionally sourced
- Dimensions vary based upon the source

**NOTE** - Contact your local sales representative for a detailed cut sheet with applicable dimensions.

### **CEILING DIFFUSERS**

#### **Field Installed**

##### **Ceiling Diffusers (Flush or Step-Down)**

- White powder coat finish on diffuser face and grilles
- Insulated UL listed duct liner
- Diffuser box has collars for duct connection
- Step-down diffusers have double deflection blades
- Flush diffusers have fixed blades
- Provisions for suspending
- Internally sealed to prevent recirculation
- Removable return air grille
- Adapts to T-bar ceiling grids or plaster ceilings

##### **Transitions (Supply and Return)**

- Used with diffusers
- Installs in roof curb
- Galvanized steel construction
- Flanges furnished for duct connection to diffusers
- Fully insulated

## HUMIDITROL™+ DEHUMIDIFICATION SYSTEM OPTION

### OVERVIEW

- Factory installed option designed to control humidity
- 17 • Humiditrol™+ utilizes advanced control algorithms, variable speed technology and a reheat coil to efficiently control humidity levels independent of room temperature
- Provides dehumidification on demand using ASHRAE 90.1 recommended method for comfort conditioning humidity control
- Unit comes equipped with one row reheat coil and solenoid valve

**NOTE** - A dehumidification demand from a relative humidity sensor, dehumidistat, a DDC controller or building automation system is required to control humidity

### BENEFITS

- Improves indoor air quality
- Discharge air control for overcool protection
- Adjustable discharge air temperature setpoint
- Energy efficient dehumidification
- Modulating latent and sensible capacity
- Helps prevent damage due to high humidity levels
- Improves comfort levels by reducing space humidity levels

### OPERATION

#### **No Dehumidification Demand**

- The unit will operate conventionally whenever there is a demand for cooling or heating and no dehumidification demand
- Free cooling is only permitted when there is no demand for dehumidification

#### **Dehumidification Demand Only**

- Reheat operation will initiate on a dehumidification demand and does not require a cooling demand
- The unit will operate in hot gas reheat dehumidification mode until the relative humidity of the conditioned space is below the setpoint
- A solenoid valve diverts hot gas from the compressor to the reheat coil
- The cooled and dehumidified air from the evaporator is reheated as it passes through the reheat coil
- The de-superheated and partially condensed refrigerant continues to the outdoor condenser coil where condensing is completed
- Unit will continue to operate in this mode until the dehumidification demand is satisfied
- The reheat coil is sized to provide optimal reheat performance without overheating supply air
- The compressor will modulate based on dehumidification load
- The outdoor fans modulate speed to provide discharge air temperature control in reheat mode

#### **Dehumidification and Cooling Demand (Thermostat/ Room Sensor Application)**

- If both a dehumidification and a cooling demand occur, the system will operate in cooling until the cooling demand is satisfied
- Then the system will energize the dehumidification mode

**NOTE** - See Sequence of Operation for additional information.

# HUMIDITROL™ + DEHUMIDIFICATION SYSTEM OPTION

## REFRIGERANT SCHEMATIC (156 AND 180 MODELS)

NOTE - Two refrigerant circuits operate during reheat.

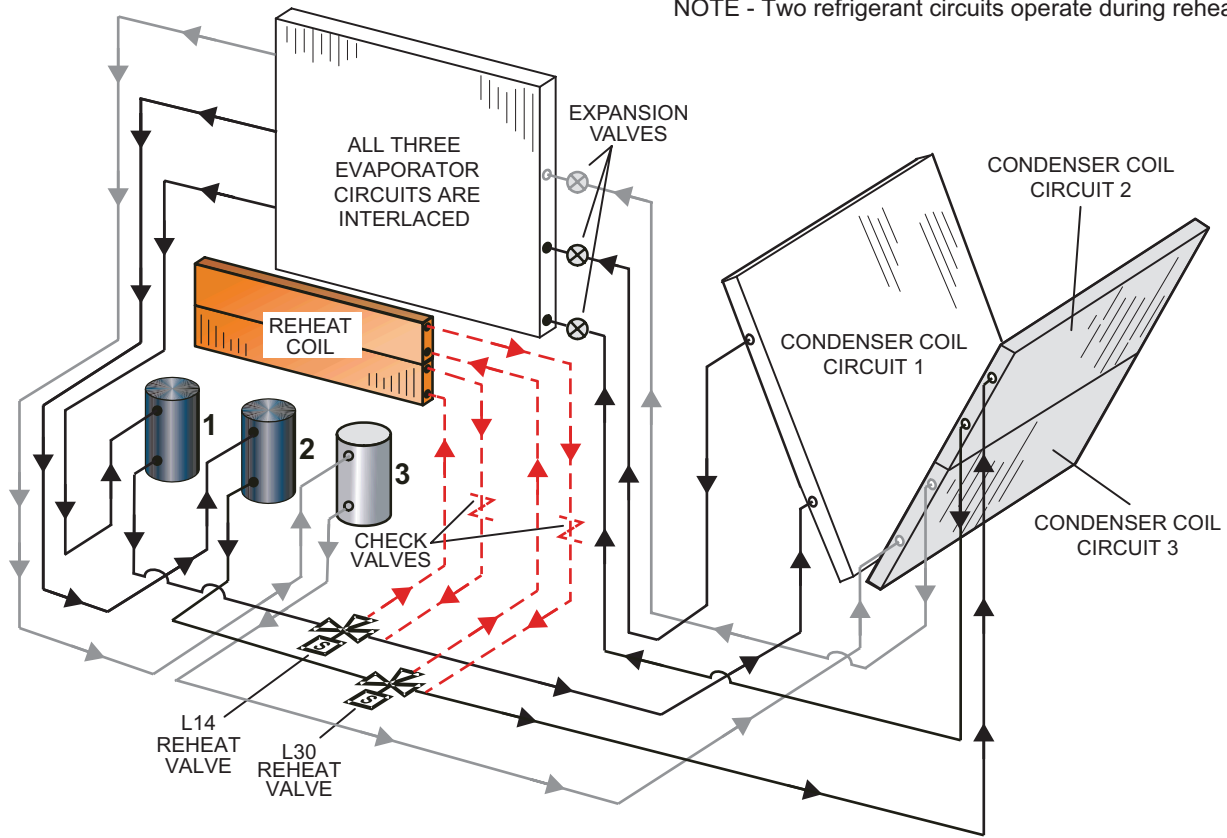

## REFRIGERANT SCHEMATIC (210, 240 and 300 MODELS ONLY)

NOTE - Two refrigerant circuits operate during reheat.

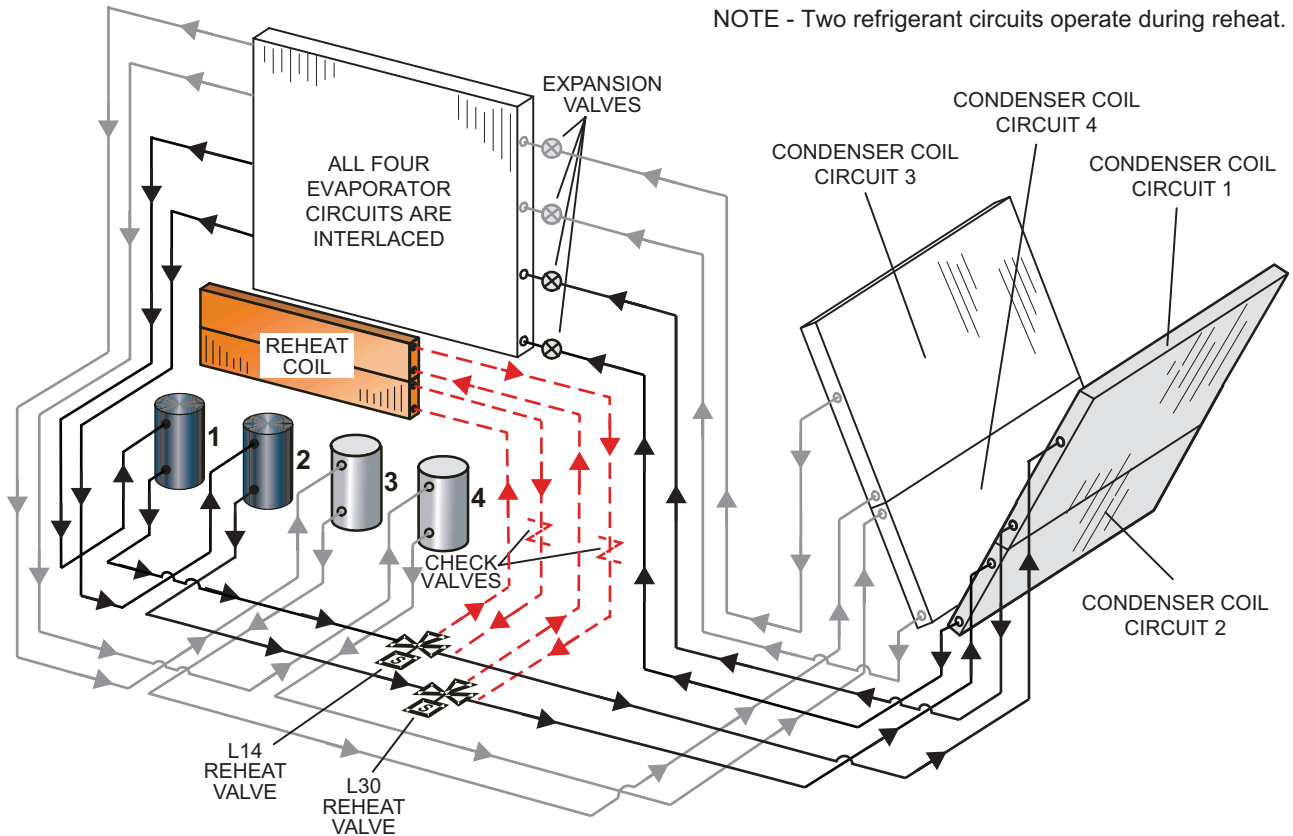

## OPTIONAL CONVENTIONAL TEMPERATURE CONTROL SYSTEMS

### CS8500 Commercial 7-Day Programmable Thermostat

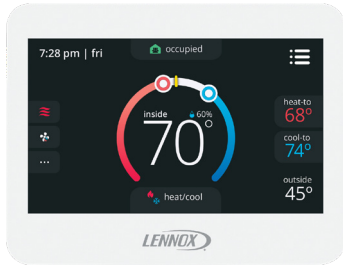

- Fully Communicating Sensor
- Full Color Touchscreen Interface
- Variable Speed System Control (On Compatible Units)
- Up To 4 Heat / 4 Cool
- Built-In Sensors For Temperature, Humidity And Optional CO<sub>2</sub>
- Remote Sensor Options For Occupancy, Temperature
- BACnet Capable Options
- 5-2 or 7-Day Scheduling
- Smooth Setback Recovery
- Heat/Cool Auto-Changeover
- Four-Wire Installation
- FDD, ASHRAE, IECC Compliant

### CS7500 Commercial 7-Day Programmable Thermostat



- Premium Universal Thermostat
- Full Color Touchscreen Interface
- Up To 4 Heat / 3 Cool
- Built-In Sensors For Temperature and Humidity
- Remote Sensors Options For Temperature, Discharge Air, Outdoor Air
- 5-2 or 7-Day Scheduling
- Smooth Setback Recovery
- Heat/Cool Auto-Changeover
- FDD, ASHRAE, IECC Compliant

### CS3000 Commercial 5-2 Day Programmable Thermostat

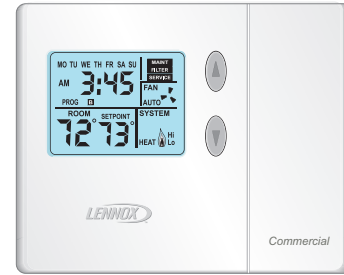

- Conventional Multi-Stage Thermostat
- Intuitive Display
- Push-Button Operation
- Up To 2 Heat / 2 Cool
- Built-In Temperature Sensor
- Remote Temperature Sensing
- Up to 5-2 Day Scheduling
- Smooth Setback Recovery
- Heat/Cool Auto-changeover

### Wired Temperature/Humidity Room Sensor (Non-Communicating)



- Terminal blocks for wiring connections
- Five-wire sensor connection
- Off-white plastic enclosure
- Non-adjustable
- Relative humidity range: 0 -100%
- +/- 3% Accuracy

## OPTIONAL CONVENTIONAL TEMPERATURE CONTROL SYSTEMS

Description	Order Number
<b>CS8500 Commercial 7 Day Programmable Thermostat</b>	
CS8500 7-Day Thermostat	No CO <sub>2</sub> Sensing <b>24K55</b>
	With CO <sub>2</sub> Sensing <b>24K53</b>
Sensors/Accessories	<sup>1</sup> Remote non-adjustable wall-mount 10k <b>47W37</b>
	<sup>1</sup> Remote non-adjustable wall-mount 11k <b>94L61</b>
<b>Sysbus Network Cable (Yellow) for CS8500 and LCS-5030 Wired Room Sensor</b>	
Twisted pair 100% shielded communication cable, Red and Black	500 ft. box <b>27M19</b>
22 AWG, yellow jacket, rated at 75°C, 300V, Plenum rated	1000 ft. box <b>94L63</b>
Insulation - Low smoke PVC, NEC, CMP	2500 ft. roll <b>68M25</b>
<b>CS7500 Commercial 7-Day Programmable Thermostat</b>	
CS7500 7-Day Thermostat	<b>24K41</b>
Sensors/Accessories	<sup>2</sup> Remote non-adjustable wall-mount 20k <b>47W36</b>
	<sup>2</sup> Remote non-adjustable wall-mount 10k <b>47W37</b>
	Remote non-adjustable discharge air (duct mount) <b>19L22</b>
	Outdoor temperature sensor <b>X2658</b>
<b>CS3000 Commercial 5-2 Day Programmable Thermostat</b>	
CS3000 5-2 Day Thermostat	<b>11Y05</b>
Sensors/Accessories	Remote non-adjustable wall mount 10k averaging <b>47W37</b>
	Thermostat wall mounting plate <b>X2659</b>
<b>Universal Thermostat Guard with Lock (clear)</b>	
	Inside Dimensions (H x W x D) 5-7/8 x 8-3/8 x 3 in. <b>39P21</b>
<b>Temperature/Humidity Room Sensor</b>	
A335MT13AE1 Wired Temperature/Humidity Room Sensor (Non-Communicating)	<b>21W06</b>

<sup>1</sup> Up to nine of the same type remote temperature sensors can be connected in parallel.

<sup>2</sup> Remote wall-mount sensors can be applied in any of the following combinations:

One Sensor - (1) 47W36, Two Sensors - (2) 47W37, Three Sensors - (2) 47W36 and (1) 47W37

Four Sensors - (4) 47W36, Five Sensors - (3) 47W36 and (2) 47W37

## SEQUENCE OF OPERATION

### COOLING

#### **A-Two-Stage Thermostat**

1 - Economizer With Outdoor Air Suitable

##### **Y1 Demand**

- Compressors Off
- Blower Cooling Low
- Dampers Modulate

*NOTE - If dampers are at maximum open for five minutes, blower runs at cooling high.*

##### **Y2 Demand**

- Compressors Modulate
- Blower Cooling High
- Dampers Maximum Open

2 - No Economizer or Outdoor Air Not Suitable

##### **Y1 Demand**

- Compressors Modulate
- Blower Cooling Low
- Dampers Minimum Position

##### **Y2 Demand**

- Compressors Modulate
- Blower Cooling High
- Dampers Minimum Position

#### **B-Three-Stage Thermostat**

1 - Economizer With Outdoor Air Suitable

##### **Y1 Demand**

- Compressors Off
- Blower Cooling Low
- Dampers Modulate

*NOTE - If dampers are at maximum open for five minutes, blower runs at cooling intermediate.*

##### **Y2 Demand**

- Compressors Modulate
- Blower Cooling Intermediate
- Dampers Maximum Open

##### **Y3 Demand**

- Compressors Modulate
- Blower Cooling High
- Dampers Maximum Open

## SEQUENCE OF OPERATION

### COOLING (CONTINUED)

2 - No Economizer or Outdoor Air Not Suitable

#### **Y1 Demand**

- Compressors Modulate
- Blower Cooling Low
- Dampers Minimum Position

#### **Y2 Demand**

- Compressors Modulate
- Blower Cooling Intermediate
- Dampers Minimum Position

#### **Y3 Demand**

- Compressors Modulate
- Blower Cooling High
- Dampers Minimum Position

### **C - Room Sensor**

1 - Economizer With Outdoor Air Suitable

- Compressors Off
- Blower Modulates
- Dampers Modulate

*NOTE - If dampers are at maximum open for five minutes, compressors are energized and the blower modulates.*

2 - No Economizer or Outdoor Air Not Suitable

- Compressors Modulate
- Blower Modulates
- Dampers Minimum Position

*NOTE - Free cooling is locked out when a dehumidification demand is received. The unit operates in dehumidification.*

### **HEATING**

*NOTE - Heating Mode can be set to 2 stage in thermostat mode or at 4 stage in room sensor mode control options.*

#### **2 STAGE OPERATION:**

##### **W1 Demand:**

- Both gas valves are open on Low Fire (stage 1 on units with 2-stage gas valves) and supply air blower operates at heating speed

##### **W2 Demand:**

- Both gas valves are open on High Fire (stage 2 on units with 2-stage gas valves) and supply air blower operates at heating speed

#### **4 STAGE OPERATION:**

##### **W1 Demand:**

- Left heat exchanger gas valve is open on Low Fire (stage 1 on units with 4-stage gas valves) and supply air blower operates at heating speed

##### **W2 Demand:**

- Both gas valves are open on Low Fire (stage 2 on units with 4-stage gas valves) and supply air blower operates at heating speed

##### **W3 Demand:**

- Left heat exchanger gas valve will open on High Fire and the right heat exchanger will remain open on Low Fire (stage 3 on units with 4-stage gas valves) and supply air blower operates at heating speed

##### **W4 Demand:**

- Both gas valves are open on High Fire (stage 4 on units with 4-stage gas valves) and supply air blower operates at heating speed

## SEQUENCE OF OPERATION

### **HEATING - MODULATING**

#### **Modulating Heating Mode: Thermostat (Up to 2 stages W1, W2)**

##### W1 or Low Heating Demand

Supply fan operates at low heating speed and Gas valves stage up/down and modulate to maintain Discharge Air Temperature (DAT) set-point.

##### W2 or High Heating Demand

Supply fan operates at high heating speed and Gas valves stage up/down and modulates to maintain Discharge Air Temperature (DAT) set-point.

##### Modulating Heating Mode: Zone Sensor

Heating demand is based on delta and duration of Zone Air Temperature (ZAT) away from ZAT set-point. Based on heating demand, supply fan modulates between low heating speed and high heating speed while Gas valves stage up/down and modulate to maintain Discharge Air Temperature (DAT) set-point as the blower speed changes.

## SEQUENCE OF OPERATION

### **HUMIDITROL™+**

#### **A - Thermostat Mode With 24V Humidistat**

Dehumidification Demand (DI4) and No Cooling Demand

Compressor 1 operates at 100% and reheat valve is energized, blower and outdoor fans modulate to maintain indoor coil and discharge air temperatures, all other compressors are off.

*NOTE: After 5 minutes of only a Dehumidification demand (DI4), compressor 2 is turned on and reheat valve is energized.*

Y1 and DI4 Demand

Compressors are modulating, blower is on cooling low, and the reheat valves are de-energized.

Y2 and DI4 Demand

Compressors are modulating, blower is on cooling high, and the reheat valves are de-energized.

#### **B - Thermostat Mode With Zone Relative Humidity Sensor**

Dehumidification Demand (RH% Setpoint < Zone RH% < RH% Setpoint +2%) and No Cooling Demand

Compressor 1 modulates based on zone relative humidity, blower and outdoor fans modulate to maintain indoor coil and discharge air temperatures, reheat valve is energized. All other compressors are off.

Dehumidification Demand (RH% Setpoint < Zone RH% for 5 minutes or Zone RH% > RH% Setpoint +2%) and No Cooling Demand

Compressor 1 modulates based on zone relative humidity and reheat valve is energized, Compressor 2 is on and reheat valve is energized, blower and outdoor fans modulate to maintain indoor coil and discharge air temperatures. All other compressors are off.

Y1 and Dehumidification Demand

Compressors are modulating, blower is on low, and the reheat valves are de-energized.

Y2 and Dehumidification Demand

Compressors are modulating, blower is on high, reheat valves are de-energized.

#### **C - Room Sensor Mode With 24V Humidistat**

Dehumidification Demand (DI4) and No Cooling Demand

Compressor 1 operates at 100%, blower and outdoor fans modulate to maintain indoor coil and discharge air temperatures, reheat valve is energized.

*NOTE: After 5 minutes of only a Dehumidification demand (DI4), compressor 2 is turned on and the reheat valve is energized.*

Cooling and Dehumidification Demand

Compressors are modulating, blower is modulating, reheat valves are de-energized.

#### **D - Room Sensor Mode With Zone Relative Humidity Sensor**

Dehumidification Demand (RH% Setpoint < Zone RH% < RH% Setpoint +2%) and No Cooling Demand

Compressor 1 modulates based on zone relative humidity, blower and outdoor fans modulate to maintain indoor coil and discharge air temperatures, reheat valve is energized. All other compressors are off.

Dehumidification Demand (RH% Setpoint < Zone RH% for 5 minutes or Zone RH% > RH% Setpoint +2%) and No Cooling Demand

Compressor 1 modulates based on zone relative humidity and reheat valve is energized, Compressor 2 is on and reheat valve is energized, blower and outdoor fans modulate to maintain indoor coil and discharge air temperatures. All other compressors are off.

Cooling and Dehumidification Demand

Compressors are modulating, blower is modulating, and the reheat valves are de-energized.

## OPTIONS / ACCESSORIES

Item Description	Order Number	Size					
		156	180	210	240	300	
<b>COOLING SYSTEM</b>							
Condensate Drain Trap	PVC	<b>22H54</b>	X	X	X	X	X
	Copper	<b>76W27</b>	X	X	X	X	X
Corrosion Protection	Factory		O	O	O	O	O
Drain Pan Overflow Switch	<b>21Z07</b>		OX	OX	OX	OX	OX
<b>HEATING SYSTEM</b>							
Bottom Gas Piping Kit	<b>85M31</b>		X	X	X	X	X
Combustion Air Intake Extensions (order two)	<b>89L97</b>		X	X	X	X	X
Gas Heat	Two-Stage Gas Heat	Factory	O	O	O	O	O
	<sup>1</sup> Modulating Gas Heat	Factory	O	O	O	O	O
Gas Heat Input	Low - 169,000 Btuh	Factory	O	O	O		
	Standard -169,000-260,000 Btuh	Factory	O	O	O	O	O
	Medium - 234,000-360,000 Btuh	Factory	O	O	O	O	O
	High - 312,000-480,000 Btuh	Factory		O	O	O	O
LPG/Propane Conversion Kits (Order 2 kits)	Low Heat	<b>14N28</b>	O				
	Standard Heat	<b>39J84</b>	O	O	O	O	O
	Medium Heat	<b>39J85</b>	O	O	O	O	O
	High Heat	<b>39J84</b>		O	O	O	O
Low Temperature Vestibule Heater	208/230V-3ph	<b>22H58</b>	X	X	X	X	X
	460V-3ph	<b>22H59</b>	X	X	X	X	X
	575V-3ph	<b>22V43</b>	X	X	X	X	X
Stainless Steel Heat Exchanger	Factory	O	O	O	O	O	
Vertical Vent Extension Kit (Order two kits)	<b>42W16</b>		X	X	X	X	X
<b>BLOWER - SUPPLY AIR</b>							
<b>Blower Option</b>							
	SZVAV (Single Zone Variable Air Volume) - With VFD Bypass Control	Factory	O	O	O	O	O
	SZVAV (Single Zone Variable Air Volume) - Without VFD Bypass Control	Factory	O	O	O	O	O
	VAV (Variable Air Volume) - Without VFD Bypass Control	Factory	O	O	O	O	O
Motors	Belt Drive (standard efficiency) - 3 HP	Factory	O	O	O		
	Belt Drive (standard efficiency) - 5 HP	Factory	O	O	O	O	O
	Belt Drive (standard efficiency) - 7.5 HP	Factory		O	O	O	O
	Belt Drive (standard efficiency) - 10 HP	Factory				O	O
Drive Kits See Blower Data Tables for usage and selection	Kit #1 535-725 rpm	Factory	O	O	O		
	Kit #2 710-965 rpm	Factory	O	O	O		
	Kit #3 685-856 rpm	Factory	O	O	O	O	O
	Kit #4 850-1045 rpm	Factory	O	O	O	O	O
	Kit #5 945-1185 rpm	Factory	O	O	O	O	O
	Kit #6 850-1045 rpm	Factory		O	O	O	O
	Kit #7 945-1185 rpm	Factory		O	O	O	O
	Kit #8 1045-1285 rpm	Factory		O	O	O	O
	Kit #10 1045-1285 rpm	Factory				O	O
	Kit #11 1135-1365 rpm	Factory				O	O
		Blower Belt Auto-Tensioner	<b>24B80</b>	X	X	X	X
<b>CONTROLS</b>							
Commercial Controls	LonTalk® Module - For Lennox® CORE Control System	<b>54W27</b>	OX	OX	OX	OX	OX
	Novar® LSE	Factory	O	O	O	O	O
Dirty Filter Switch		<b>53W68</b>	OX	OX	OX	OX	OX
<sup>1</sup> Remote Discharge Air Temperature Sensor		<b>21Z08</b>	OX	OX	OX	OX	OX
Fresh Air Tempering		<b>21Z08</b>	OX	OX	OX	OX	OX
Smoke Detector - Supply or Return (Power board and one sensor)		<b>37G73</b>	OX	OX	OX	OX	OX
Smoke Detector - Supply and Return (Power board and two sensors)		<b>37G74</b>	OX	OX	OX	OX	OX

<sup>1</sup> Modulating Gas Heat for Horizontal Applications requires a Remote Discharge Air Temperature Sensor (21Z08). Sensor is shipped with the unit for field installation if unit is configured at the factory. Sensor must be ordered separately for field installation if unit is not factory configured.

NOTE - Order numbers shown are for ordering optional accessories if a field installed option is available.

OX - Configure To Order (Factory Installed) or Field Installed

O = Configure To Order (Factory Installed)

X = Field Installed

## OPTIONS / ACCESSORIES

Item Description	Order Number	Size					
		156	180	210	240	300	
<b>INDOOR AIR QUALITY</b>							
<b>Air Filters</b>							
Healthy Climate® High Efficiency Air Filters 24 x 24 x 2 in.	MERV 8 (Order 6)	<b>54W67</b>	OX	OX	OX	OX	OX
	MERV 13 (Order 6)	<b>52W40</b>	OX	OX	OX	OX	OX
	MERV 16 (Order 6)	<b>21U52</b>	OX	OX	OX	OX	OX
Replacement Media Filter With Metal Mesh Frame 24 x 24 x 2 in. (includes non-pleated filter media)	(Order 6)	<b>44N61</b>	X	X	X	X	X
<b>Indoor Air Quality (CO<sub>2</sub>) Sensors</b>							
Sensor - Wall-mount, off-white plastic cover with LCD display		<b>77N39</b>	X	X	X	X	X
Sensor - Wall-mount, off-white plastic cover, no display		<b>87N53</b>	X	X	X	X	X
Sensor - Black plastic case, LCD display, rated for plenum mounting		<b>87N52</b>	X	X	X	X	X
Sensor - Black plastic case, no display, rated for plenum mounting		<b>87N54</b>	X	X	X	X	X
CO <sub>2</sub> Sensor Duct Mounting Kit - for downflow applications		<b>85L43</b>	X	X	X	X	X
Aspiration Box - for duct mounting non-plenum rated CO <sub>2</sub> sensors ( <b>77N39</b> )		<b>90N43</b>	X	X	X	X	X
<b>Needlepoint Bipolar Ionization (NPBI)</b>							
Needlepoint Bipolar Ionization (NPBI) Kit		<b>21U37</b>	X	X	X		
		<b>21U38</b>				X	
		<b>21U39</b>					X
<b>UVC Germicidal Light Kit</b>							
<sup>2</sup> Healthy Climate® UVC Light Kit (110/230v-1ph)		<b>21A94</b>	X	X	X	X	X
Step-Down Transformer	460V primary, 230V secondary	<b>10H20</b>	X	X	X	X	X
	575V primary, 230V secondary	<b>10H21</b>	X	X	X	X	X
<b>ELECTRICAL</b>							
Voltage 60 Hz	208/230V - 3 phase	Factory	O	O	O	O	O
	460V - 3 phase	Factory	O	O	O	O	O
	575V - 3 phase	Factory	O	O	O	O	O
HACR Circuit Breakers		Factory	O	O	O	O	O
<sup>3</sup> Short-Circuit Current Rating (SCCR) of 100kA (includes Phase/Voltage Detection)		Factory	O	O	O	O	O
Disconnect Switch (see Disconnect Table for usage, page 44)	80 amp		OX	OX	OX	OX	OX
	150 amp		OX	OX	OX	OX	OX
	250 amp						OX
GFI Service Outlets	15 amp non-powered, field-wired (208/230V, 460V only)	<b>74M70</b>	OX	OX	OX	OX	OX
	15 amp factory-wired and powered (208/230V, 460V only)	Factory	O	O	O	O	O
	<sup>4</sup> 20 amp non-powered, field-wired (208/230V, 460V, 575V)	<b>67E01</b>	X	X	X	X	X
	<sup>4</sup> 20 amp non-powered, field-wired (575V only)	Factory	O	O	O	O	O
Weatherproof Cover for GFI		<b>10C89</b>	X	X	X	X	X

<sup>2</sup> Lamps operate on 110-230V single-phase power supply. Step-down transformer may be ordered separately for 460V and 575V units. Alternately, 110V power supply may be used to directly power the UVC ballast(s).

<sup>3</sup> Disconnect Switch is furnished and factory installed with High SCCR option.

<sup>4</sup> Canada requires a minimum 20 amp circuit. Select 20 amp, non-powered, field wired GFI.

NOTE - Order numbers shown are for ordering optional accessories if a field installed option is available.

OX - Configure To Order (Factory Installed) or Field Installed

O = Configure To Order (Factory Installed)

X = Field Installed

## OPTIONS / ACCESSORIES

Item Description	Order Number	Size				
		156	180	210	240	300
<b>ECONOMIZER</b>						
<b>High Performance Economizer (Approved for California Title 24 Building Standards AMCA Class 1A Certified)</b>						
High Performance Economizer (Downflow or Horizontal) Includes Economizer Dampers with Outdoor Air Hood Downflow Applications - Use furnished Outdoor Air Hood - Order Downflow Barometric Relief Dampers with Exhaust Hood separately Horizontal Applications - Use furnished Outdoor Air Hood - Order Horizontal Barometric Relief Dampers with Exhaust Hood separately	22J18	OX	OX	OX	OX	OX
<b>Economizer Controls</b>						
Differential Enthalpy (Not for Title 24)	Order 2 21Z09	OX	OX	OX	OX	OX
Sensible Control	Sensor is Furnished Factory	O	O	O	O	O
Single Enthalpy (Not for Title 24)	21Z09	OX	OX	OX	OX	OX
Global Control	Sensor Field Provided Factory	O	O	O	O	O
Building Pressure Control	13J77	X	X	X	X	X
Outdoor Air CFM Control	13J76	X	X	X	X	X
<b>Barometric Relief Dampers With Exhaust Hood (required with economizer)</b>						
Downflow Barometric Relief Dampers	54W78	OX	OX	OX	OX	OX
Horizontal Barometric Relief Dampers	16K99	X	X	X	X	X
<b>OUTDOOR AIR</b>						
<b>Outdoor Air Dampers With Outdoor Air Hood</b>						
Motorized	22J27	OX	OX	OX	OX	OX
Manual	13U05	X	X	X	X	X
<b>5 POWER EXHAUST (DOWNFLOW APPLICATIONS ONLY)</b>						
Standard Static, SCCR Rated	208/230V 22H90	OX	OX	OX	OX	OX
	460V 22H91	OX	OX	OX	OX	OX
	575V 22V34	OX	OX	OX	OX	OX
<b>HUMIDITROL™+ HOT GAS REHEAT OPTION - SZVAV MODELS ONLY</b>						
Humiditrol+ Dehumidification Option	Factory	OX	OX	OX	OX	OX
Humidity Sensor Kit, Remote mounted (required)	17M50	X	X	X	X	X
<b>CABINET</b>						
Burglar Bars	(US) 44N20	X	X	X	X	X
	(CA) X2889	X	X	X	X	X
Combination Coil/Hail Guards	23U71	OX	OX	OX	OX	OX
Corrosion Protection	Factory	O	O	O	O	O

<sup>5</sup> Field installed Power Exhaust requires Economizer with Outdoor Air Hood and Downflow Barometric Relief Dampers with Exhaust Hood. Must be ordered separately.

NOTE - Order numbers shown are for ordering optional accessories if a field installed option is available.

OX - Configure To Order (Factory Installed) or Field Installed

O = Configure To Order (Factory Installed)

X = Field Installed

## OPTIONS / ACCESSORIES

Item Description	Order Number	Size				
		156	180	210	240	300
<b>ROOF CURBS</b>						
<b>Hybrid Roof Curbs, Downflow</b>						
8 in. height	<b>11F58</b>	X	X	X	X	X
14 in. height	<b>11F59</b>	X	X	X	X	X
18 in. height	<b>11F60</b>	X	X	X	X	X
24 in. height	<b>11F61</b>	X	X	X	X	X
<b>Adjustable Pitch Curb</b>						
14 in. height	<b>43W26</b>	X	X	X	X	X
<b>Standard Roof Curbs, Horizontal - Requires Horizontal Return Air Panel Kit</b>						
26 in. height - slab applications	<b>11T89</b>	X	X	X	X	
30 in. height - slab applications	<b>11T90</b>					X
37 in. height - rooftop applications	<b>11T96</b>	X	X	X	X	
41 in. height - rooftop applications	<b>11T97</b>					X
<b>Insulation Kit For Standard Horizontal Roof Curbs</b>						
for 26 in. height curb	<b>73K32</b>	X	X	X	X	
for 30 in. height curb	<b>73K33</b>					X
for 37 in. height curb	<b>73K34</b>	X	X	X	X	
for 41 in. height curb	<b>73K35</b>					X
<b>Horizontal Return Air Panel Kit</b>						
Required for Horizontal Applications with Roof Curb	<b>87M00</b>	X	X	X	X	X
<b>CEILING DIFFUSERS</b>						
Step-Down - Order one	RTD11-185S	<b>13K63</b>	X	X		
	RTD11-275S	<b>13K64</b>			X	X
Flush - Order one	FD11-185S	<b>13K58</b>	X	X		
	FD11-275S	<b>13K59</b>			X	X
Transitions (Supply and Return) - Order one	C1DIFF33C-1	<b>12X68</b>	X	X		
	C1DIFF34C-1	<b>12X70</b>			X	X

NOTE - Order numbers shown are for ordering optional accessories if a field installed option is available.

OX - Configure To Order (Factory Installed) or Field Installed

O = Configure To Order (Factory Installed)

X = Field Installed

**SPECIFICATIONS**
**13 TON**

Model	LGM156U5M		LGM156U5V	
<b>Nominal Tonnage</b>	13 Ton		13 Ton	
<b>Efficiency Type</b>	Ultra-High		Ultra-High	
<b>Blower Type</b>	SZVAV (Single Zone Variable Air Volume)		VAV (Variable Air Volume)	
<b>Cooling Performance</b>	Gross Cooling Capacity (Btuh)	154,000	154,000	
	<sup>1</sup> Net Cooling Capacity (Btuh)	150,000	150,000	
	<sup>1</sup> AHRI Rated Air Flow (cfm)	4100	4100	
	<sup>1</sup> IEER (Btuh/Watt)	19.0	18.5	
	<sup>1</sup> EER (Btuh/Watt)	12.0	12.0	
	Total Unit Power (kW)	12.5	12.5	
<b>Sound Rating Number</b>	dBA	86	86	
<b>Refrigerant Charge</b>	Refrigerant Type	R-454B	R-454B	
	Without Reheat Option	Circuit 1	6 lbs. 3 oz.	6 lbs. 3 oz.
		Circuit 2	5 lbs. 5 oz.	5 lbs. 5 oz.
		Circuit 3	5 lbs. 11 oz.	5 lbs. 11 oz.
	With Reheat Option	Circuit 1	6 lbs. 3 oz.	- - -
		Circuit 2	5 lbs. 5 oz.	- - -
		Circuit 3	5 lbs. 11 oz.	- - -
<b>Gas Heating Options Available</b>	See page 29			
<b>Compressor Type (number)</b>	Variable Capacity Scroll (1) Fixed Capacity Scroll (2)			
<b>Outdoor Coils</b>	Net face area - ft. <sup>2</sup>	55.2	55.2	
	Rows	1	1	
	Fins - in.	20	20	
<b>Outdoor Coil Fans</b>	Motor HP (number and type)	1/3 (4 ECM)	1/3 (4 ECM)	
	Rpm	450-1075	450-1075	
	Watts	155 - 1150	155 - 1150	
	Diameter (Number) - in.	(4) 24	(4) 24	
	Blades	3	3	
	Total Air volume - cfm	16,000	16,000	
<b>Indoor Coils</b>	Net face area - ft. <sup>2</sup>	21.40	21.40	
	Tube diameter - in.	3/8	3/8	
	Rows	3	3	
	Fins - in.	14	14	
	Condensate drain size (NPT) - in.	(1) 1	(1) 1	
	Expansion device type	Balanced Port Thermostatic Expansion Valve,removable power head		
<sup>2</sup> <b>Indoor Blower and Drive Selection</b>	Nominal motor HP	3, 5		
	Maximum usable motor HP (US)	3.45, 5.75		
	Motor - Drive kit number	3 HP		
		Kit 1 535-725 rpm		
		Kit 2 710-965 rpm		
	5 HP			
	Kit 3 685-856 rpm			
	Kit 4 850-1045 rpm			
	Kit 5 945-1185 rpm			
	Blower wheel nominal diameter x width - in.	(2) 15 x 15 in.	(2) 15 x 15 in.	
<b>Filters</b>	Type of filter	MERV 4, Disposable		
	Number and size - in.	(6) 24 x 24 x 2		
<b>Line voltage data (Volts-Phase-Hz)</b>	208/230-3-60, 460-3-60, 575-3-60			

NOTE - Net capacity includes evaporator blower motor heat deduction. Gross capacity does not include evaporator blower motor heat deduction.

<sup>1</sup> AHRI Certified to AHRI Standard 340/360; 95°F outdoor air temperature and 80°F db/67°F wb entering evaporator air; minimum external duct static pressure.

<sup>2</sup> Using total air volume and system static pressure requirements determine from blower performance tables rpm and motor output required. Maximum usable output of motors furnished are shown. In Canada, nominal motor output is also maximum usable motor output. If motors of comparable output are used, be sure to keep within the service factor limitations outlined on the motor nameplate.

NOTE – Blower motor service factor = 1.0.

**SPECIFICATIONS**

**15 TON | 17.5 TON**

Model		LGM180U5M	LGM180U5V	LGM210U5M	LGM210U5V	
<b>Nominal Tonnage</b>		15 Ton	15 Ton	17.5 Ton	17.5 Ton	
<b>Efficiency Type</b>		Ultra-High	Ultra-High	Ultra-High	Ultra-High	
<b>Blower Type</b>		SZVAV (Single Zone Variable Air Volume)	VAV (Variable Air Volume)	SZVAV (Single Zone Variable Air Volume)	VAV (Variable Air Volume)	
<b>Cooling Performance</b>	Gross Cooling Capacity (Btuh)	176,000	176,000	206,000	206,000	
	<sup>1</sup> Net Cooling Capacity (Btuh)	172,000	172,000	200,000	200,000	
	<sup>1</sup> AHRI Rated Air Flow (cfm)	5250	5250	6100	6100	
	<sup>1</sup> IEER (Btuh/Watt)	19.0	17.5	18.8	18.0	
	<sup>1</sup> EER (Btuh/Watt)	12.0	12.0	12.0	12.0	
	Total Unit Power (kW)	14.3	14.3	16.7	16.7	
<b>Sound Rating Number</b>	dBA	86	86	90	90	
<b>Refrigerant Charge</b>	Refrigerant Type	R-454B	R-454B	R-454B	R-454B	
	Without Reheat Option	Circuit 1	6 lbs. 4 oz.	6 lbs. 4 oz.	5 lbs. 14 oz.	5 lbs. 14 oz.
		Circuit 2	6 lbs. 2 oz.	6 lbs. 2 oz.	5 lbs. 12 oz.	5 lbs. 12 oz.
		Circuit 3	5 lbs. 8 oz.	5 lbs. 8 oz.	5 lbs. 0 oz.	5 lbs. 0 oz.
		Circuit 4	- - -	- - -	5 lbs. 4 oz.	5 lbs. 4 oz.
	With Reheat Option	Circuit 1	6 lbs. 4 oz.	- - -	5 lbs. 14 oz.	- - -
		Circuit 2	6 lbs. 2 oz.	- - -	5 lbs. 12 oz.	- - -
		Circuit 3	5 lbs. 8 oz.	- - -	5 lbs. 0 oz.	- - -
		Circuit 4	- - -	- - -	5 lbs. 4 oz.	- - -
<b>Gas Heating Options Available</b>		See page 29				
<b>Compressor Type (number)</b>		Variable Capacity Scroll (1) Fixed Capacity Scroll (2)	Variable Capacity Scroll (1) Fixed Capacity Scroll (3)			
<b>Outdoor Coils</b>	Net face area - ft. <sup>2</sup>	55.2	55.2	55.2	55.2	
	Rows	1	1	1	1	
	Fins - in.	20	20	20	20	
<b>Outdoor Coil Fans</b>	Motor HP (number and type)	1/3 (4 ECM)	1/3 (4 ECM)	1/3 (6 ECM)	1/3 (6 ECM)	
	Rpm	280-1075	280-1075	640-950	640-950	
	Watts	150 -1350	150 -1350	290 -1250	290 -1250	
	Diameter (Number) - in.	(4) 24	(4) 24	(6) 24	(6) 24	
	Blades	3	3	3	3	
	Total Air volume - cfm	16,000	16,000	18,600	18,600	
<b>Indoor Coils</b>	Net face area - ft. <sup>2</sup>	21.40	21.40	21.40	21.40	
	Tube diameter - in.	3/8	3/8	3/8	3/8	
	Rows	3	3	3	3	
	Fins - in.	14	14	14	14	
	Condensate drain size (NPT) - in.	(1) 1	(1) 1	(1) 1	(1) 1	
	Expansion device type	Balanced Port Thermostatic Expansion Valve, removable power head				
<b><sup>2</sup> Indoor Blower and Drive Selection</b>	Nominal motor HP	3, 5, 7.5				
	Maximum usable motor HP (US)	3.45, 5.75, 8.62				
	Motor - Drive kit number	3 HP				
		Kit 1 535-725 rpm				
		Kit 2 710-965 rpm				
		5 HP				
		Kit 3 685-856 rpm				
		Kit 4 850-1045 rpm				
		Kit 5 945-1185 rpm				
		7.5 HP				
Blower wheel nominal diameter x width - in.	Kit 6 850-1045 rpm					
	Kit 7 945-1185 rpm					
<b>Filters</b>	Type of filter	MERV 4, Disposable				
	Number and size - in.	(6) 24 x 24 x 2				
<b>Line voltage data (Volts-Phase-Hz)</b>		208/230-3-60, 460-3-60, 575-3-60				

NOTE - Net capacity includes evaporator blower motor heat deduction. Gross capacity does not include evaporator blower motor heat deduction.

<sup>1</sup> AHRI Certified to AHRI Standard 340/360; 95°F outdoor air temperature and 80°F db/67°F wb entering evaporator air; minimum external duct static pressure.

<sup>2</sup> Using total air volume and system static pressure requirements determine from blower performance tables rpm and motor output required. Maximum usable output of motors furnished are shown. In Canada, nominal motor output is also maximum usable motor output. If motors of comparable output are used, be sure to keep within the service factor limitations outlined on the motor nameplate.

NOTE – Blower motor service factor = 1.0.

**SPECIFICATIONS**

**20 TON | 25 TON**

Model		LGM240U5M	LGM240U5V	LGM300U5M	LGM300U5V	
<b>Nominal Tonnage</b>		20 Ton	20 Ton	25 Ton	25 Ton	
<b>Efficiency Type</b>		Ultra-High	Ultra-High	Ultra-High	Ultra-High	
<b>Blower Type</b>		SZVAV (Single Zone Variable Air Volume)	VAV (Variable Air Volume)	SZVAV (Single Zone Variable Air Volume)	VAV (Variable Air Volume)	
<b>Cooling Performance</b>	Gross Cooling Capacity (Btuh)	235,000	235,000	277,000	277,000	
	<sup>1</sup> Net Cooling Capacity (Btuh)	228,000	228,000	270,000	270,000	
	<sup>1</sup> AHRI Rated Air Flow (cfm)	6450	6450	7400	7400	
	<sup>1</sup> IEER (Btuh/Watt)	18.4	17.5	17.5	16.5	
	<sup>1</sup> EER (Btuh/Watt)	12	12	10.6	10.6	
	Total Unit Power (kW)	19	19	25.5	25.5	
<b>Sound Rating Number</b>	dBA	90	90	90	90	
<b>Refrigerant Charge</b>	Refrigerant Type	R-454B	R-454B	R-454B	R-454B	
	Without Reheat Option	Circuit 1	6 lbs. 1 oz.	6 lbs. 1 oz.	6 lbs. 12 oz.	6 lbs. 12 oz.
		Circuit 2	5 lbs. 11 oz.	5 lbs. 11 oz.	6 lbs. 12 oz.	6 lbs. 12 oz.
		Circuit 3	5 lbs. 2 oz.	5 lbs. 2 oz.	6 lbs. 3 oz.	6 lbs. 3 oz.
		Circuit 4	5 lbs. 8 oz.	5 lbs. 8 oz.	5 lbs. 15 oz.	5 lbs. 15 oz.
	With Reheat Option	Circuit 1	6 lbs. 14 oz.	---	6 lbs. 12 oz.	---
		Circuit 2	6 lbs. 13 oz.	---	6 lbs. 12 oz.	---
		Circuit 3	4 lbs. 11 oz.	---	6 lbs. 3 oz.	---
		Circuit 4	4 lbs. 13 oz.	---	5 lbs. 15 oz.	---
<b>Gas Heating Options Available</b>		See page 29				
<b>Compressor Type (number)</b>		Variable Capacity Scroll (1) Fixed Capacity Scroll (3)				
<b>Outdoor Coils</b>	Net face area - ft. <sup>2</sup>	55.2	55.2	55.2	55.2	
	Number of rows	1	1	1	1	
	Fins - in.	20	20	20	20	
<b>Outdoor Coil Fans</b>	Motor HP (number and type)	1/3 (6 ECM)	1/3 (6 ECM)	1/3 (6 ECM)	1/3 (6 ECM)	
	Rpm	450 - 950	450 - 950	515 - 1000	515 - 1000	
	Watts	130 -1530	130 -1530	180 - 1730	180 - 1730	
	Diameter (Number) - in.	(6) 24	(6) 24	(6) 24	(6) 24	
	Blades	3	3	3	3	
	Total Air volume - cfm	18,000	18,000	18,300	18,300	
<b>Indoor Coils</b>	Net face area - ft. <sup>2</sup>	21.40	21.40	21.40	21.40	
	Tube diameter - in.	3/8	3/8	3/8	3/8	
	Rows	4	4	4	4	
	Fins - in.	14	14	14	14	
	Condensate drain size (NPT) - in.	(1) 1	(1) 1	(1) 1	(1) 1	
	Expansion device type	Balanced Port Thermostatic Expansion Valve,removable power head				
<b><sup>2</sup> Indoor Blower and Drive Selection</b>	Nominal motor HP	5, 7.5, 10				
	Maximum usable motor HP (US)	5.75, 8.62, 11.5				
	Motor - Drive kit number	5 HP				
		Kit 3 685-856 rpm				
		Kit 4 850-1045 rpm				
		Kit 5 945-1185 rpm				
		7.5 HP				
		Kit 6 850-1045 rpm				
		Kit 7 945-1185 rpm				
		Kit 8 1045-1285 rpm				
		10 HP				
Kit 7 945-1185 rpm						
Kit 10 1045-1285 rpm						
Kit 11 1135-1330 rpm						
	Blower wheel nominal diameter x width - in.	(2) 15 x 15				
<b>Filters</b>	Type of filter	MERV 4, Disposable				
	Number and size - in.	(6) 24 x 24 x 2				
<b>Line voltage data (Volts-Phase-Hz)</b>		208/230-3-60, 460-3-60, 575-3-60				

NOTE - Net capacity includes evaporator blower motor heat deduction. Gross capacity does not include evaporator blower motor heat deduction.

<sup>1</sup> AHRI Certified to AHRI Standard 340/360; 95°F outdoor air temperature and 80°F db/67°F wb entering evaporator air; minimum external duct static pressure.

<sup>2</sup> Using total air volume and system static pressure requirements determine from blower performance tables rpm and motor output required. Maximum usable output of motors furnished are shown. In Canada, nominal motor output is also maximum usable motor output. If motors of comparable output are used, be sure to keep within the service factor limitations outlined on the motor nameplate.

NOTE – Blower motor service factor = 1.0.

## SPECIFICATIONS - GAS HEAT

Model			LGM156 LGM180 LGM210	LGM156 LGM180 LGM210 LGM240 LGM300	LGM180 LGM210 LGM240 LGM300	
<b>Heat Input Type</b>			<b>Low (L)</b>	<b>Standard (S)</b>	<b>Medium (M)</b>	<b>High (H)</b>
<b>Gas Heating Performance</b>	Input - Btuh	Minimum	169,000	85,000	117,000	156,000
		Maximum	169,000	260,000	360,000	480,000
	Output - Btuh	Maximum	135,000	211,000	292,000	389,000
Temperature Rise Range - °F			15-45	15-45	30-60	40-70
Minimum Air Volume - cfm			3000	4500	4500	5125
Thermal Efficiency			80%	81%	81%	81%
Gas Supply Connections			1 in. NPT	1 in. NPT	1 in. NPT	1 in. NPT
Recommended Gas Supply Pressure - in. w.g.	Natural		7	7	7	7
	LPG/Propane		11	11	11	11
Gas Supply Pressure Range	Min./Max. (Natural)		4.7 - 10.5 in. w.g.			
	Min./Max. (LPG)		10.8 - 13.5 in.w.g.			

NOTE - Modulating Gas Heat operates between the minimum and maximum gas heat inputs shown.

NOTE - Air volume may modulate below minimum volume if heat input is below maximum.

## HIGH ALTITUDE DERATE

**NOTE** - Units may be installed at altitudes up to 2000 feet above sea level without any modification.

At altitudes above 2000 feet, units must be derated to match gas manifold pressures shown in table below.

At altitudes above 4500 feet units must be derated 4% for each 1000 feet above sea level.

**NOTE** - This is the only permissible derate for these units.

**NOTE** - Low Heat Input does not need to be derated.

Refer to the Installation Instructions for more detailed information.

Heat Input Type	Altitude Feet	Gas Manifold Pressure - in. w.g.		Input Rate (Btuh)	
		Natural Gas	LPG/Propane Gas	Minimum	Maximum
Standard	2001 - 4500	1.6 / 3.1	4.4 / 8.9	85,000	239,000
Medium	2001 - 4500	1.6 / 3.1	4.4 / 8.9	117,000	331,000
High	2001 - 4500	1.6 / 3.1	4.4 / 8.9	156,000	442,000

# COOLING RATINGS

NOTE – For Temperatures and Capacities not shown in tables, see bulletin – Cooling Unit Rating Table Correction Factor Data in Miscellaneous Engineering Data section.

## 13 TON - LGM156U5M/V (ONE COMPRESSOR OPERATING)

Entering Wet Bulb Temperature	Total Air Volume	Outdoor Air Temperature Entering Outdoor Coil																			
		65°F					75°F					85°F					95°F				
		Total Cool Cap.	Comp. Motor Input	Sensible To Total Ratio (S/T)			Total Cool Cap.	Comp. Motor Input	Sensible To Total Ratio (S/T)			Total Cool Cap.	Comp. Motor Input	Sensible To Total Ratio (S/T)			Total Cool Cap.	Comp. Motor Input	Sensible To Total Ratio (S/T)		
				Dry Bulb					Dry Bulb					Dry Bulb					Dry Bulb		
cfm	kBtuh	kW	75°F	80°F	85°F	kBtuh	kW	75°F	80°F	85°F	kBtuh	kW	75°F	80°F	85°F	kBtuh	kW	75°F	80°F	85°F	
63°F	1200	31.3	0.76	0.83	0.98	1	29.4	0.94	0.83	0.98	1	27.5	1.17	0.84	0.99	1	25.6	1.43	0.86	1	1
	1500	32.9	0.74	0.89	1	1	31.1	0.94	0.91	1	1	29.2	1.17	0.93	1	1	27.3	1.43	0.94	1	1
	1800	34.5	0.73	0.95	1	1	32.6	0.93	0.96	1	1	30.7	1.17	0.96	1	1	28.7	1.43	0.97	1	1
67°F	1200	33	0.74	0.53	0.78	0.96	31.1	0.94	0.53	0.79	0.97	29.1	1.17	0.52	0.8	0.98	27.1	1.43	0.52	0.82	0.98
	1500	34.6	0.73	0.57	0.85	0.99	32.5	0.93	0.57	0.87	0.99	30.5	1.17	0.57	0.89	1	28.4	1.43	0.57	0.93	1
	1800	35.7	0.72	0.62	0.93	1	33.6	0.92	0.62	0.94	1	31.5	1.16	0.62	0.95	1	29.3	1.43	0.63	0.96	1
71°F	1200	35	0.73	0.25	0.5	0.74	33	0.93	0.23	0.5	0.75	31	1.17	0.21	0.5	0.76	28.9	1.43	0.18	0.49	0.78
	1500	36.5	0.72	0.25	0.55	0.81	34.5	0.92	0.23	0.55	0.83	32.3	1.17	0.21	0.55	0.85	30.1	1.43	0.19	0.55	0.87
	1800	37.7	0.71	0.26	0.59	0.88	35.5	0.92	0.24	0.6	0.92	33.3	1.17	0.23	0.61	0.94	31	1.43	0.21	0.61	0.95

NOTE - Compressor operating at maximum capacity.

## 13 TON - LGM156U5M/V (TWO COMPRESSORS OPERATING)

Entering Wet Bulb Temperature	Total Air Volume	Outdoor Air Temperature Entering Outdoor Coil																			
		65°F					75°F					85°F					95°F				
		Total Cool Cap.	Comp. Motor Input	Sensible To Total Ratio (S/T)			Total Cool Cap.	Comp. Motor Input	Sensible To Total Ratio (S/T)			Total Cool Cap.	Comp. Motor Input	Sensible To Total Ratio (S/T)			Total Cool Cap.	Comp. Motor Input	Sensible To Total Ratio (S/T)		
				Dry Bulb					Dry Bulb					Dry Bulb					Dry Bulb		
cfm	kBtuh	kW	75°F	80°F	85°F	kBtuh	kW	75°F	80°F	85°F	kBtuh	kW	75°F	80°F	85°F	kBtuh	kW	75°F	80°F	85°F	
63°F	3120	114	4.08	0.72	0.84	0.93	108.3	4.74	0.73	0.85	0.94	103	5.46	0.74	0.86	0.95	97.6	6.27	0.75	0.87	0.96
	3900	120.8	4.06	0.77	0.88	0.97	114.6	4.74	0.79	0.89	0.98	109.4	5.48	0.79	0.9	0.99	103.3	6.29	0.79	0.91	1
	4680	126.3	4.05	0.8	0.92	0.99	120	4.74	0.82	0.93	1	114.2	5.48	0.82	0.94	1	108.3	6.31	0.83	0.95	1
67°F	3120	120.3	4.05	0.55	0.69	0.82	113.9	4.73	0.54	0.7	0.82	108.3	5.47	0.54	0.7	0.83	102.4	6.28	0.53	0.7	0.84
	3900	126.2	4.04	0.56	0.74	0.86	119.4	4.72	0.58	0.75	0.87	113.2	5.47	0.57	0.76	0.87	106.9	6.3	0.57	0.77	0.89
	4680	130.4	4.02	0.6	0.78	0.89	123.3	4.71	0.59	0.8	0.91	116.8	5.47	0.61	0.8	0.92	110.5	6.31	0.6	0.82	0.93
71°F	3120	126.8	4.03	0.37	0.51	0.65	120.3	4.71	0.35	0.51	0.65	114.2	5.46	0.34	0.51	0.66	108.2	6.3	0.33	0.5	0.66
	3900	133.1	4.01	0.36	0.54	0.71	126.1	4.71	0.36	0.54	0.72	119.8	5.48	0.35	0.55	0.72	113.3	6.32	0.34	0.55	0.74
	4680	137.7	3.99	0.38	0.58	0.75	130.3	4.71	0.37	0.58	0.76	123.7	5.48	0.36	0.58	0.79	116.9	6.33	0.35	0.58	0.79

NOTE - Compressors operating at maximum capacity.

## 13 TON - LGM156U5M/V (THREE COMPRESSORS OPERATING)

Entering Wet Bulb Temperature	Total Air Volume	Outdoor Air Temperature Entering Outdoor Coil																			
		85°F					95°F					105°F					115°F				
		Total Cool Cap.	Comp. Motor Input	Sensible To Total Ratio (S/T)			Total Cool Cap.	Comp. Motor Input	Sensible To Total Ratio (S/T)			Total Cool Cap.	Comp. Motor Input	Sensible To Total Ratio (S/T)			Total Cool Cap.	Comp. Motor Input	Sensible To Total Ratio (S/T)		
				Dry Bulb					Dry Bulb					Dry Bulb					Dry Bulb		
cfm	kBtuh	kW	75°F	80°F	85°F	kBtuh	kW	75°F	80°F	85°F	kBtuh	kW	75°F	80°F	85°F	kBtuh	kW	75°F	80°F	85°F	
63°F	4160	155.7	7.78	0.71	0.82	0.93	146.9	8.92	0.71	0.83	0.94	139.2	10.25	0.71	0.84	0.96	130.4	11.74	0.73	0.86	0.98
	5200	165.5	7.78	0.75	0.87	0.98	156.4	8.93	0.76	0.89	0.99	148.4	10.27	0.77	0.9	1	138.8	11.72	0.78	0.92	1
	6240	173	7.77	0.79	0.92	1	163.6	8.94	0.8	0.94	1	154.4	10.26	0.81	0.96	1	144.8	11.73	0.83	0.98	1
67°F	4160	163.6	7.77	0.55	0.68	0.8	152.7	8.91	0.56	0.69	0.81	145.6	10.24	0.55	0.69	0.82	134.9	11.72	0.55	0.72	0.83
	5200	170.6	7.76	0.59	0.74	0.85	161.6	8.92	0.58	0.74	0.86	152.4	10.25	0.6	0.75	0.88	142.8	11.72	0.6	0.76	0.9
	6240	177.8	7.76	0.61	0.77	0.9	168.1	8.94	0.62	0.78	0.92	158.6	10.26	0.63	0.79	0.94	148.1	11.74	0.63	0.81	0.96
71°F	4160	173.4	7.76	0.41	0.54	0.66	164.2	8.93	0.4	0.53	0.68	153	10.24	0.4	0.56	0.69	143.2	11.72	0.4	0.56	0.69
	5200	180.3	7.75	0.43	0.58	0.72	170.5	8.93	0.43	0.59	0.73	162.3	10.27	0.42	0.58	0.73	151.6	11.75	0.41	0.59	0.75
	6240	186.4	7.73	0.43	0.61	0.76	178.1	8.95	0.44	0.62	0.77	166.4	10.27	0.43	0.63	0.79	155	11.75	0.43	0.63	0.8

NOTE - Compressors operating at maximum capacity.

# COOLING RATINGS

NOTE – For Temperatures and Capacities not shown in tables, see bulletin – Cooling Unit Rating Table Correction Factor Data in Miscellaneous Engineering Data section.

## 15 TON - LGM180U5M/V (ONE COMPRESSOR OPERATING)

Entering Wet Bulb Temperature	Total Air Volume	Outdoor Air Temperature Entering Outdoor Coil																			
		65°F					75°F					85°F					95°F				
		Total Cool Cap.	Comp. Motor Input	Sensible To Total Ratio (S/T)			Total Cool Cap.	Comp. Motor Input	Sensible To Total Ratio (S/T)			Total Cool Cap.	Comp. Motor Input	Sensible To Total Ratio (S/T)			Total Cool Cap.	Comp. Motor Input	Sensible To Total Ratio (S/T)		
				Dry Bulb					Dry Bulb					Dry Bulb					Dry Bulb		
cfm	kBtuh	kW	75°F	80°F	85°F	kBtuh	kW	75°F	80°F	85°F	kBtuh	kW	75°F	80°F	85°F	kBtuh	kW	75°F	80°F	85°F	
63°F	1600	46.8	0.67	1	1	1	43.6	0.82	1	1	1	40.6	1.01	1	1	1	37.7	1.23	1	1	1
	2000	49.8	0.65	1	1	1	46.6	0.81	1	1	1	43.5	1	1	1	1	40.4	1.23	1	1	1
	2400	52.2	0.65	1	1	1	48.9	0.8	1	1	1	45.6	1	1	1	1	42.4	1.22	1	1	1
67°F	1600	49.5	0.66	1	1	1	46.1	0.81	1	1	1	42.8	1.01	1	1	1	39.4	1.23	1	1	1
	2000	51.6	0.65	1	1	1	48.1	0.8	1	1	1	44.7	1	1	1	1	41.2	1.22	1	1	1
	2400	53.2	0.64	1	1	1	49.6	0.8	1	1	1	46.1	1	1	1	1	42.6	1.22	1	1	1
71°F	1600	52.7	0.65	0.93	1	1	49.2	0.8	0.82	1	1	45.8	1	0.74	1	1	42.3	1.23	0.61	1	1
	2000	54.7	0.64	0.98	1	1	51.1	0.8	0.89	1	1	47.5	1	0.8	1	1	44	1.22	0.7	1	1
	2400	56.2	0.64	1	1	1	52.5	0.8	0.98	1	1	48.8	1	0.9	1	1	45.2	1.23	0.8	1	1

NOTE - Compressor operating at maximum capacity.

## 15 TON - LGM180U5M/V (TWO COMPRESSORS OPERATING)

Entering Wet Bulb Temperature	Total Air Volume	Outdoor Air Temperature Entering Outdoor Coil																			
		65°F					75°F					85°F					95°F				
		Total Cool Cap.	Comp. Motor Input	Sensible To Total Ratio (S/T)			Total Cool Cap.	Comp. Motor Input	Sensible To Total Ratio (S/T)			Total Cool Cap.	Comp. Motor Input	Sensible To Total Ratio (S/T)			Total Cool Cap.	Comp. Motor Input	Sensible To Total Ratio (S/T)		
				Dry Bulb					Dry Bulb					Dry Bulb					Dry Bulb		
cfm	kBtuh	kW	75°F	80°F	85°F	kBtuh	kW	75°F	80°F	85°F	kBtuh	kW	75°F	80°F	85°F	kBtuh	kW	75°F	80°F	85°F	
63°F	3600	120	3.88	0.79	0.9	0.97	113.1	4.52	0.78	0.91	0.97	105.7	5.22	0.79	0.91	0.98	99.1	6	0.79	0.92	0.99
	4500	127.8	3.84	0.85	0.93	0.99	120.8	4.49	0.84	0.94	0.99	113.2	5.2	0.84	0.95	1	105.7	5.99	0.86	0.96	1
	5400	134	3.81	0.88	0.96	1	126.3	4.46	0.87	0.97	1	118.5	5.18	0.88	0.97	1	110.9	5.98	0.89	0.98	1
67°F	3600	127	3.83	0.58	0.76	0.88	119.8	4.47	0.58	0.75	0.89	111.6	5.19	0.57	0.75	0.89	104.2	5.98	0.56	0.75	0.9
	4500	133.4	3.79	0.61	0.81	0.91	125.7	4.45	0.62	0.81	0.92	117.4	5.17	0.61	0.83	0.93	109.1	5.96	0.59	0.84	0.94
	5400	138	3.75	0.65	0.86	0.94	129.4	4.43	0.64	0.86	0.95	121.4	5.15	0.65	0.87	0.96	113.5	5.96	0.63	0.88	0.97
71°F	3600	134.9	3.77	0.38	0.55	0.72	127	4.44	0.36	0.56	0.71	118.9	5.15	0.35	0.55	0.71	111.6	5.96	0.32	0.54	0.71
	4500	141.6	3.73	0.39	0.59	0.78	133.4	4.4	0.37	0.58	0.78	124.9	5.14	0.37	0.59	0.79	116.8	5.95	0.35	0.59	0.79
	5400	146.5	3.69	0.42	0.62	0.82	137.9	4.38	0.4	0.63	0.84	129.1	5.13	0.39	0.62	0.85	120.8	5.94	0.37	0.64	0.85

NOTE - Compressors operating at maximum capacity.

## 15 TON - LGM180U5M/V (THREE COMPRESSORS OPERATING)

Entering Wet Bulb Temperature	Total Air Volume	Outdoor Air Temperature Entering Outdoor Coil																			
		85°F					95°F					105°F					115°F				
		Total Cool Cap.	Comp. Motor Input	Sensible To Total Ratio (S/T)			Total Cool Cap.	Comp. Motor Input	Sensible To Total Ratio (S/T)			Total Cool Cap.	Comp. Motor Input	Sensible To Total Ratio (S/T)			Total Cool Cap.	Comp. Motor Input	Sensible To Total Ratio (S/T)		
				Dry Bulb					Dry Bulb					Dry Bulb					Dry Bulb		
cfm	kBtuh	kW	75°F	80°F	85°F	kBtuh	kW	75°F	80°F	85°F	kBtuh	kW	75°F	80°F	85°F	kBtuh	kW	75°F	80°F	85°F	
63°F	4800	175.4	9.5	0.7	0.82	0.92	164.2	10.83	0.7	0.82	0.93	152.8	12.32	0.71	0.83	0.95	141.1	14.03	0.71	0.84	0.96
	6000	187.2	9.53	0.75	0.86	0.97	175.9	10.86	0.75	0.88	0.98	163.5	12.37	0.76	0.89	0.99	150.9	14.08	0.76	0.91	1
	7200	196.5	9.55	0.78	0.91	1	184.6	10.89	0.79	0.93	1	171.5	12.4	0.8	0.95	1	158.3	14.11	0.81	0.97	1
67°F	4800	183.9	9.52	0.55	0.68	0.79	172.4	10.85	0.54	0.69	0.8	160.5	12.35	0.53	0.7	0.81	147	14.04	0.53	0.69	0.82
	6000	193.5	9.53	0.57	0.72	0.84	181.8	10.87	0.58	0.73	0.85	169.4	12.38	0.57	0.73	0.87	156.5	14.09	0.56	0.74	0.88
	7200	202.3	9.55	0.62	0.77	0.89	189.8	10.9	0.6	0.77	0.9	176.8	12.42	0.62	0.78	0.92	163.2	14.14	0.6	0.79	0.94
71°F	4800	196.5	9.54	0.41	0.53	0.67	184.6	10.89	0.38	0.54	0.67	171.6	12.39	0.38	0.53	0.67	158.1	14.1	0.35	0.52	0.68
	6000	206.8	9.56	0.41	0.58	0.71	193.8	10.92	0.41	0.57	0.72	180.3	12.44	0.39	0.56	0.72	164.6	14.12	0.37	0.58	0.73
	7200	212.5	9.56	0.44	0.61	0.75	199	10.92	0.42	0.6	0.76	187.1	12.47	0.41	0.61	0.77	171.6	14.18	0.41	0.61	0.78

NOTE - Compressors operating at maximum capacity.

# COOLING RATINGS

NOTE – For Temperatures and Capacities not shown in tables, see bulletin – Cooling Unit Rating Table Correction Factor Data in Miscellaneous Engineering Data section.

## 17.5 TON - LGM210U5M/V (ONE COMPRESSOR OPERATING)

Entering Wet Bulb Temperature	Total Air Volume	Outdoor Air Temperature Entering Outdoor Coil																				
		65°F						75°F					85°F					95°F				
		Total Cool Cap.	Comp. Motor Input	Sensible To Total Ratio (S/T)			Total Cool Cap.	Comp. Motor Input	Sensible To Total Ratio (S/T)			Total Cool Cap.	Comp. Motor Input	Sensible To Total Ratio (S/T)			Total Cool Cap.	Comp. Motor Input	Sensible To Total Ratio (S/T)			
				Dry Bulb					Dry Bulb					Dry Bulb					Dry Bulb			
cfm	kBtuh	kW	75°F	80°F	85°F	kBtuh	kW	75°F	80°F	85°F	kBtuh	kW	75°F	80°F	85°F	kBtuh	kW	75°F	80°F	85°F		
63°F	1600	48.2	1.57	0.82	0.95	1	44.9	1.86	0.82	0.96	1	41.7	2.19	0.82	0.96	1	38.2	2.55	0.82	0.97	1	
	2000	51	1.57	0.88	0.98	1	47.6	1.86	0.88	0.98	1	44	2.19	0.88	0.99	1	40.9	2.56	0.89	0.99	1	
	2400	53.2	1.57	0.91	0.99	1	49.8	1.86	0.91	1	1	46	2.2	0.92	1	1	42.8	2.57	0.93	1	1	
67°F	1600	51.1	1.57	0.53	0.78	0.94	47.8	1.86	0.51	0.78	0.94	44.5	2.19	0.49	0.77	0.94	41.1	2.56	0.46	0.77	0.95	
	2000	53.9	1.57	0.56	0.85	0.97	50.3	1.86	0.55	0.85	0.97	46.6	2.2	0.54	0.85	0.98	43.3	2.57	0.52	0.87	0.98	
	2400	55.9	1.57	0.6	0.89	0.99	52.3	1.87	0.59	0.89	0.99	48.4	2.21	0.58	0.9	1	44.8	2.58	0.57	0.91	1	
71°F	1600	54.7	1.57	0.23	0.49	0.73	51.3	1.86	0.2	0.48	0.73	47.9	2.2	0.16	0.46	0.73	44.4	2.57	0.11	0.44	0.73	
	2000	57.3	1.57	0.24	0.53	0.8	53.8	1.87	0.2	0.52	0.8	49.9	2.21	0.17	0.51	0.81	46.5	2.58	0.13	0.5	0.82	
	2400	59.3	1.57	0.24	0.57	0.86	55.3	1.87	0.21	0.57	0.87	51.6	2.21	0.18	0.56	0.88	47.8	2.59	0.15	0.55	0.89	

NOTE - Compressor operating at maximum capacity.

## 17.5 TON - LGM210U5M/V (TWO COMPRESSORS OPERATING)

Entering Wet Bulb Temperature	Total Air Volume	Outdoor Air Temperature Entering Outdoor Coil																				
		65°F						75°F					85°F					95°F				
		Total Cool Cap.	Comp. Motor Input	Sensible To Total Ratio (S/T)			Total Cool Cap.	Comp. Motor Input	Sensible To Total Ratio (S/T)			Total Cool Cap.	Comp. Motor Input	Sensible To Total Ratio (S/T)			Total Cool Cap.	Comp. Motor Input	Sensible To Total Ratio (S/T)			
				Dry Bulb					Dry Bulb					Dry Bulb					Dry Bulb			
cfm	kBtuh	kW	75°F	80°F	85°F	kBtuh	kW	75°F	80°F	85°F	kBtuh	kW	75°F	80°F	85°F	kBtuh	kW	75°F	80°F	85°F		
63°F	2800	101	3.86	0.72	0.85	0.97	94.6	4.47	0.72	0.86	0.98	87.8	5.16	0.72	0.87	0.99	81	5.94	0.73	0.88	1	
	3500	107.9	3.88	0.77	0.91	1	100.7	4.49	0.77	0.93	1	94	5.2	0.78	0.94	1	86.7	5.98	0.78	0.96	1	
	4200	113.3	3.9	0.81	0.97	1	106	4.52	0.82	0.98	1	98.7	5.23	0.83	0.99	1	91.7	6.02	0.84	1	1	
67°F	2800	107.6	3.88	0.57	0.71	0.83	100.5	4.49	0.57	0.71	0.83	93.2	5.19	0.56	0.71	0.84	86.5	5.98	0.55	0.71	0.86	
	3500	114	3.9	0.61	0.75	0.89	106.8	4.52	0.6	0.76	0.9	99.2	5.23	0.6	0.76	0.92	91.4	6.01	0.59	0.77	0.93	
	4200	118.9	3.92	0.64	0.8	0.94	111	4.54	0.64	0.81	0.96	103.7	5.26	0.63	0.81	0.97	95.6	6.04	0.63	0.83	0.99	
71°F	2800	114.2	3.9	0.43	0.57	0.69	106.9	4.52	0.41	0.56	0.69	99.7	5.22	0.4	0.55	0.69	92.1	6.01	0.38	0.55	0.7	
	3500	121.2	3.92	0.45	0.6	0.74	113.3	4.55	0.44	0.6	0.74	105.4	5.27	0.42	0.6	0.75	97.7	6.06	0.41	0.59	0.76	
	4200	125.9	3.94	0.46	0.63	0.78	117.9	4.58	0.46	0.63	0.79	109.7	5.3	0.44	0.63	0.8	101.7	6.1	0.42	0.63	0.82	

NOTE - Compressors operating at maximum capacity.

## 17.5 TON - LGM210U5M/V (THREE COMPRESSORS OPERATING)

Entering Wet Bulb Temperature	Total Air Volume	Outdoor Air Temperature Entering Outdoor Coil																				
		85°F						95°F					105°F					115°F				
		Total Cool Cap.	Comp. Motor Input	Sensible To Total Ratio (S/T)			Total Cool Cap.	Comp. Motor Input	Sensible To Total Ratio (S/T)			Total Cool Cap.	Comp. Motor Input	Sensible To Total Ratio (S/T)			Total Cool Cap.	Comp. Motor Input	Sensible To Total Ratio (S/T)			
				Dry Bulb					Dry Bulb					Dry Bulb					Dry Bulb			
cfm	kBtuh	kW	75°F	80°F	85°F	kBtuh	kW	75°F	80°F	85°F	kBtuh	kW	75°F	80°F	85°F	kBtuh	kW	75°F	80°F	85°F		
63°F	4200	142.6	8.85	0.8	0.96	1	131.6	10.17	0.78	0.96	1	120.8	11.64	0.8	0.96	1	108.8	13.29	0.8	0.97	1	
	5250	152.3	8.93	0.88	0.98	1	141.6	10.26	0.89	0.98	1	129.6	11.74	0.9	0.99	1	117.6	13.39	0.89	0.99	1	
	6300	160.2	9.01	0.92	0.99	1	148.9	10.35	0.93	1	1	136.6	11.82	0.94	1	1	124.4	13.48	0.95	1	1	
67°F	4200	152.9	8.93	0.53	0.76	0.94	141.5	10.25	0.51	0.76	0.94	129.2	11.71	0.46	0.75	0.95	116.9	13.37	0.43	0.75	0.95	
	5250	161.1	9.01	0.58	0.84	0.97	148.6	10.33	0.55	0.87	0.97	136	11.8	0.53	0.87	0.98	123.1	13.45	0.5	0.88	0.98	
	6300	166.3	9.06	0.61	0.91	0.99	154.2	10.4	0.6	0.92	0.99	141.6	11.87	0.57	0.93	0.99	128.2	13.52	0.55	0.93	1	
71°F	4200	165	9.03	0.27	0.5	0.71	152.6	10.35	0.23	0.48	0.71	140.2	11.83	0.19	0.46	0.7	127.4	13.48	0.12	0.42	0.71	
	5250	172.3	9.11	0.27	0.53	0.8	160	10.45	0.24	0.52	0.81	147.2	11.92	0.2	0.5	0.83	133.5	13.57	0.15	0.48	0.86	
	6300	177.9	9.18	0.3	0.59	0.89	164.7	10.51	0.26	0.57	0.9	151.5	11.99	0.22	0.58	0.91	137.8	13.64	0.17	0.57	0.93	

NOTE - Compressors operating at maximum capacity.

## 17.5 TON - LGM210U5M/V (FOUR COMPRESSORS OPERATING)

Entering Wet Bulb Temperature	Total Air Volume	Outdoor Air Temperature Entering Outdoor Coil																				
		85°F						95°F					105°F					115°F				
		Total Cool Cap.	Comp. Motor Input	Sensible To Total Ratio (S/T)			Total Cool Cap.	Comp. Motor Input	Sensible To Total Ratio (S/T)			Total Cool Cap.	Comp. Motor Input	Sensible To Total Ratio (S/T)			Total Cool Cap.	Comp. Motor Input	Sensible To Total Ratio (S/T)			
				Dry Bulb					Dry Bulb					Dry Bulb					Dry Bulb			
cfm	kBtuh	kW	75°F	80°F	85°F	kBtuh	kW	75°F	80°F	85°F	kBtuh	kW	75°F	80°F	85°F	kBtuh	kW	75°F	80°F	85°F		
63°F	5600	205.8	11.2	0.69	0.83	0.92	191.4	12.86	0.68	0.83	0.93	176.5	14.73	0.69	0.84	0.95	160.2	16.85	0.69	0.85	0.96	
	7000	221.1	11.25	0.75	0.88	0.98	206	12.92	0.76	0.89	0.99	190.5	14.8	0.76	0.9	1	173.2	16.92	0.78	0.91	1	
	8400	233.1	11.29	0.8	0.92	1	217	12.97	0.81	0.94	1	200.8	14.86	0.82	0.95	1	183	16.98	0.83	0.97	1	
67°F	5600	219.1	11.25	0.52	0.66	0.81	203.5	12.91	0.51	0.67	0.81	187.5	14.78	0.5	0.67	0.82	170.2	16.89	0.48	0.67	0.83	
	7000	231.5	11.3	0.55	0.74	0.86	215.2	12.97	0.54	0.73	0.87	198.3	14.85	0.55	0.75	0.88	180.1	16.95	0.53	0.77	0.89	
	8400	241	11.34	0.59	0.8	0.9	224.5	13.02	0.58	0.79	0.92	207.2	14.9	0.58	0.8	0.93	189.4	17.02	0.58	0.81	0.95	
71°F	5600	235.4	11.3	0.37	0.52	0.64	218.9	12.98	0.35	0.49	0.66	202.8	14.86	0.33	0.5	0.66	184.2	16.97	0.29	0.47	0.66	
	7000	247.2	11.36	0.39	0.56	0.7	230.4	13.04	0.37	0.54	0.72	212.6	14.93	0.36	0.54	0.73	193.8	17.05	0.32	0.53	0.74	
	8400	256.6	11.4	0.41	0.58	0.77	238.5	13.09	0.39	0.58	0.78	219.9	14.98	0.36	0.59	0.79	200.8	17.11	0.32	0.59	0.8	

NOTE - Compressors operating at maximum capacity.

# COOLING RATINGS

NOTE – For Temperatures and Capacities not shown in tables, see bulletin – Cooling Unit Rating Table Correction Factor Data in Miscellaneous Engineering Data section.

## 20 TON - LGM240U5M/V (ONE COMPRESSOR OPERATING)

Entering Wet Bulb Temperature	Total Air Volume	Outdoor Air Temperature Entering Outdoor Coil																			
		65°F					75°F					85°F					95°F				
		Total Cool Cap.	Comp. Motor Input	Sensible To Total Ratio (S/T)			Total Cool Cap.	Comp. Motor Input	Sensible To Total Ratio (S/T)			Total Cool Cap.	Comp. Motor Input	Sensible To Total Ratio (S/T)			Total Cool Cap.	Comp. Motor Input	Sensible To Total Ratio (S/T)		
				Dry Bulb					Dry Bulb					Dry Bulb					Dry Bulb		
cfm	kBtuh	kW	75°F	80°F	85°F	kBtuh	kW	75°F	80°F	85°F	kBtuh	kW	75°F	80°F	85°F	kBtuh	kW	75°F	80°F	85°F	
63°F	1600	50	1.85	0.6	0.76	0.91	47.3	2.16	0.59	0.77	0.92	44.9	2.5	0.6	0.79	0.94	42.3	2.87	0.6	0.8	0.96
	2000	53	1.85	0.63	0.82	0.97	50.2	2.17	0.63	0.83	0.98	47.6	2.51	0.64	0.85	1	44.5	2.89	0.65	0.87	1
	2400	55.4	1.85	0.67	0.87	1	52.5	2.17	0.68	0.89	1	49.6	2.52	0.69	0.91	1	46.7	2.9	0.7	0.93	1
67°F	1600	52.7	1.85	0.39	0.55	0.72	50	2.16	0.38	0.55	0.73	47.4	2.51	0.37	0.55	0.74	44.5	2.88	0.36	0.56	0.75
	2000	55.6	1.85	0.4	0.59	0.78	52.7	2.17	0.4	0.6	0.79	49.9	2.52	0.39	0.6	0.81	47.1	2.9	0.39	0.61	0.82
	2400	57.8	1.85	0.42	0.63	0.83	54.8	2.18	0.42	0.64	0.85	51.6	2.53	0.42	0.66	0.87	48.8	2.92	0.41	0.66	0.89
71°F	1600	55.9	1.85	0.18	0.36	0.52	53.1	2.17	0.16	0.35	0.51	50.1	2.52	0.14	0.34	0.51	47.5	2.9	0.12	0.33	0.52
	2000	58.8	1.85	0.17	0.37	0.55	55.5	2.18	0.16	0.37	0.56	52.6	2.54	0.14	0.36	0.57	49.8	2.92	0.12	0.36	0.57
	2400	60.9	1.85	0.17	0.39	0.59	57.4	2.18	0.16	0.39	0.6	54.7	2.55	0.14	0.39	0.62	51.6	2.94	0.13	0.39	0.63

NOTE - Compressor operating at maximum capacity.

## 20 TON - LGM240U5M/V (TWO COMPRESSORS OPERATING)

Entering Wet Bulb Temperature	Total Air Volume	Outdoor Air Temperature Entering Outdoor Coil																			
		65°F					75°F					85°F					95°F				
		Total Cool Cap.	Comp. Motor Input	Sensible To Total Ratio (S/T)			Total Cool Cap.	Comp. Motor Input	Sensible To Total Ratio (S/T)			Total Cool Cap.	Comp. Motor Input	Sensible To Total Ratio (S/T)			Total Cool Cap.	Comp. Motor Input	Sensible To Total Ratio (S/T)		
				Dry Bulb					Dry Bulb					Dry Bulb					Dry Bulb		
cfm	kBtuh	kW	75°F	80°F	85°F	kBtuh	kW	75°F	80°F	85°F	kBtuh	kW	75°F	80°F	85°F	kBtuh	kW	75°F	80°F	85°F	
63°F	3200	108.7	4.1	0.73	0.85	0.96	103	4.74	0.73	0.86	0.97	97.2	5.43	0.74	0.87	0.98	91	6.19	0.74	0.88	0.99
	4000	115.8	4.11	0.77	0.9	1	109.6	4.74	0.78	0.91	1	102.7	5.44	0.78	0.93	1	96.7	6.21	0.79	0.95	1
	4800	120.9	4.11	0.8	0.95	1	114.6	4.75	0.81	0.96	1	108.2	5.45	0.83	0.98	1	101.6	6.22	0.84	0.99	1
67°F	3200	114.5	4.11	0.58	0.71	0.82	108.4	4.74	0.58	0.71	0.83	102	5.44	0.57	0.72	0.84	95.4	6.2	0.57	0.72	0.86
	4000	121.2	4.11	0.6	0.75	0.88	114.3	4.75	0.6	0.76	0.89	107.7	5.45	0.61	0.77	0.9	101.1	6.22	0.61	0.78	0.93
	4800	125.7	4.1	0.63	0.79	0.93	119.2	4.75	0.63	0.8	0.94	112.1	5.46	0.64	0.81	0.96	105.2	6.23	0.64	0.82	0.97
71°F	3200	121.2	4.1	0.43	0.56	0.69	114.5	4.75	0.43	0.56	0.7	108	5.45	0.42	0.56	0.7	101.6	6.22	0.41	0.56	0.7
	4000	127.9	4.1	0.44	0.6	0.73	121.1	4.76	0.44	0.59	0.74	113.7	5.46	0.43	0.6	0.75	106.7	6.23	0.43	0.6	0.76
	4800	133	4.1	0.46	0.63	0.78	125.8	4.76	0.45	0.63	0.79	117.9	5.47	0.45	0.63	0.8	110.6	6.25	0.44	0.64	0.81

NOTE - Compressors operating at maximum capacity.

## 20 TON - LGM240U5M/V (THREE COMPRESSORS OPERATING)

Entering Wet Bulb Temperature	Total Air Volume	Outdoor Air Temperature Entering Outdoor Coil																			
		85°F					95°F					105°F					115°F				
		Total Cool Cap.	Comp. Motor Input	Sensible To Total Ratio (S/T)			Total Cool Cap.	Comp. Motor Input	Sensible To Total Ratio (S/T)			Total Cool Cap.	Comp. Motor Input	Sensible To Total Ratio (S/T)			Total Cool Cap.	Comp. Motor Input	Sensible To Total Ratio (S/T)		
				Dry Bulb					Dry Bulb					Dry Bulb					Dry Bulb		
cfm	kBtuh	kW	75°F	80°F	85°F	kBtuh	kW	75°F	80°F	85°F	kBtuh	kW	75°F	80°F	85°F	kBtuh	kW	75°F	80°F	85°F	
63°F	4800	161	8.99	0.77	0.92	0.98	151.5	10.23	0.77	0.93	0.98	140.7	11.58	0.77	0.94	0.99	130.8	13.12	0.78	0.95	0.99
	6000	170.1	9.02	0.83	0.96	0.99	160.2	10.26	0.83	0.96	0.99	150.5	11.62	0.86	0.97	1	139.9	13.16	0.87	0.97	1
	7200	178.3	9.04	0.88	0.97	1	168.3	10.28	0.9	0.98	1	157.9	11.65	0.9	0.98	1	146.8	13.18	0.91	0.99	1
67°F	4800	170.2	9.02	0.5	0.71	0.9	160.1	10.26	0.49	0.71	0.91	149.8	11.62	0.45	0.71	0.92	138.8	13.15	0.44	0.74	0.93
	6000	178.8	9.04	0.51	0.79	0.94	168.8	10.29	0.52	0.82	0.95	157.4	11.65	0.51	0.83	0.95	145.7	13.18	0.49	0.84	0.96
	7200	185.5	9.06	0.56	0.85	0.96	174.3	10.31	0.54	0.88	0.97	163.1	11.68	0.54	0.88	0.97	150.8	13.2	0.56	0.9	0.98
71°F	4800	181.9	9.05	0.25	0.47	0.67	170.1	10.29	0.23	0.43	0.66	159.6	11.66	0.22	0.43	0.66	148.2	13.19	0.17	0.41	0.67
	6000	189.9	9.08	0.26	0.48	0.75	178.8	10.32	0.25	0.47	0.75	167.5	11.69	0.21	0.46	0.79	155	13.22	0.19	0.46	0.82
	7200	196.6	9.09	0.27	0.52	0.84	184.6	10.34	0.26	0.53	0.84	172.5	11.71	0.22	0.54	0.86	160.3	13.24	0.19	0.53	0.87

NOTE - Compressors operating at maximum capacity.

## 20 TON - LGM240U5M/V (FOUR COMPRESSORS OPERATING)

Entering Wet Bulb Temperature	Total Air Volume	Outdoor Air Temperature Entering Outdoor Coil																			
		85°F					95°F					105°F					115°F				
		Total Cool Cap.	Comp. Motor Input	Sensible To Total Ratio (S/T)			Total Cool Cap.	Comp. Motor Input	Sensible To Total Ratio (S/T)			Total Cool Cap.	Comp. Motor Input	Sensible To Total Ratio (S/T)			Total Cool Cap.	Comp. Motor Input	Sensible To Total Ratio (S/T)		
				Dry Bulb					Dry Bulb					Dry Bulb					Dry Bulb		
cfm	kBtuh	kW	75°F	80°F	85°F	kBtuh	kW	75°F	80°F	85°F	kBtuh	kW	75°F	80°F	85°F	kBtuh	kW	75°F	80°F	85°F	
63°F	6400	236.5	13.65	0.68	0.84	0.92	224	15.45	0.68	0.83	0.93	209.8	17.44	0.77	0.85	0.94	195.1	19.71	0.71	0.86	0.96
	8000	252.4	13.69	0.74	0.87	0.97	238.6	15.49	0.74	0.88	0.98	223.8	17.48	0.77	0.9	0.99	209	19.74	0.79	0.91	1
	9600	265.5	13.71	0.8	0.91	1	250.1	15.52	0.8	0.93	1	234.9	17.51	0.82	0.94	1	219.1	19.77	0.83	0.96	1
67°F	6400	251	13.68	0.51	0.65	0.81	236.6	15.48	0.51	0.67	0.81	221	17.46	0.51	0.68	0.82	205.3	19.73	0.5	0.69	0.83
	8000	264.3	13.71	0.53	0.72	0.85	249	15.51	0.55	0.72	0.86	232.9	17.5	0.54	0.75	0.87	216.1	19.76	0.54	0.76	0.89
	9600	274	13.73	0.57	0.77	0.89	257.5	15.53	0.58	0.79	0.91	241.3	17.52	0.58	0.81	0.92	224.7	19.78	0.58	0.83	0.94
71°F	6400	266.4	13.71	0.37	0.49	0.63	251.3	15.51	0.35	0.49	0.63	235.3	17.5	0.34	0.5	0.65	219.3	19.76	0.33	0.5	0.66
	8000	279.1	13.74	0.39	0.53	0.69	263.3	15.54	0.38	0.53	0.71	247.2	17.53	0.36	0.52	0.71	230	19.79	0.33	0.54	0.74
	9600	288.8	13.76	0.39	0.58	0.76	272	15.56	0.36	0.58	0.76	255.2	17.55	0.37	0.57	0.78	237.5	19.81	0.36	0.59	0.8

NOTE - Compressors operating at maximum capacity.

# COOLING RATINGS

NOTE – For Temperatures and Capacities not shown in tables, see bulletin – Cooling Unit Rating Table Correction Factor Data in Miscellaneous Engineering Data section.

## 25 TON - LGM300U5M/V (ONE COMPRESSOR OPERATING)

Entering Wet Bulb Temperature	Total Air Volume	Outdoor Air Temperature Entering Outdoor Coil																			
		65°F					75°F					85°F					95°F				
		Total Cool Cap.	Comp. Motor Input	Sensible To Total Ratio (S/T)			Total Cool Cap.	Comp. Motor Input	Sensible To Total Ratio (S/T)			Total Cool Cap.	Comp. Motor Input	Sensible To Total Ratio (S/T)			Total Cool Cap.	Comp. Motor Input	Sensible To Total Ratio (S/T)		
				Dry Bulb					Dry Bulb					Dry Bulb					Dry Bulb		
cfm	kBtuh	kW	75°F	80°F	85°F	kBtuh	kW	75°F	80°F	85°F	kBtuh	kW	75°F	80°F	85°F	kBtuh	kW	75°F	80°F	85°F	
63°F	2000	55.9	2.02	0.86	1	1	53.8	2.36	0.88	1	1	51.8	2.73	0.9	1	1	49.5	3.12	0.92	1	1
	2500	58.7	2.02	0.93	1	1	56.6	2.37	0.95	1	1	54.4	2.74	0.96	1	1	51.9	3.14	0.97	1	1
	3000	60.9	2.02	0.97	1	1	58.3	2.37	0.97	1	1	56.1	2.75	0.98	1	1	54.2	3.15	0.99	1	1
67°F	2000	58.5	2.02	0.56	0.81	0.98	56.3	2.37	0.56	0.83	0.99	53.9	2.74	0.57	0.85	0.99	52	3.14	0.58	0.86	1
	2500	61.2	2.02	0.59	0.88	1	58.5	2.37	0.6	0.91	1	56.2	2.75	0.62	0.93	1	54.1	3.15	0.63	0.95	1
	3000	63.1	2.01	0.63	0.95	1	60.3	2.37	0.65	0.96	1	58.1	2.76	0.66	0.97	1	55.3	3.16	0.68	0.98	1
71°F	2000	61.2	2.02	0.23	0.51	0.76	58.7	2.37	0.23	0.52	0.77	56.4	2.75	0.23	0.53	0.79	54.4	3.15	0.23	0.54	0.81
	2500	63.8	2.01	0.24	0.55	0.83	61.2	2.37	0.24	0.57	0.85	59	2.76	0.24	0.58	0.87	56.3	3.17	0.24	0.59	0.9
	3000	65.9	2.01	0.25	0.6	0.9	63.3	2.38	0.25	0.61	0.93	60.5	2.77	0.25	0.63	0.95	57.9	3.18	0.26	0.65	0.96

NOTE - Compressor operating at maximum capacity.

## 25 TON - LGM300U5M/V (TWO COMPRESSORS OPERATING)

Entering Wet Bulb Temperature	Total Air Volume	Outdoor Air Temperature Entering Outdoor Coil																			
		65°F					75°F					85°F					95°F				
		Total Cool Cap.	Comp. Motor Input	Sensible To Total Ratio (S/T)			Total Cool Cap.	Comp. Motor Input	Sensible To Total Ratio (S/T)			Total Cool Cap.	Comp. Motor Input	Sensible To Total Ratio (S/T)			Total Cool Cap.	Comp. Motor Input	Sensible To Total Ratio (S/T)		
				Dry Bulb					Dry Bulb					Dry Bulb					Dry Bulb		
cfm	kBtuh	kW	75°F	80°F	85°F	kBtuh	kW	75°F	80°F	85°F	kBtuh	kW	75°F	80°F	85°F	kBtuh	kW	75°F	80°F	85°F	
63°F	4000	128.2	5.34	0.75	0.89	0.99	123.1	6.13	0.76	0.9	1	117.7	7.02	0.77	0.92	1	112.7	8.02	0.79	0.94	1
	5000	134.2	5.36	0.8	0.95	1	129.3	6.17	0.81	0.96	1	123.7	7.07	0.83	0.98	1	118.7	8.08	0.84	0.99	1
	6000	139.6	5.39	0.85	0.99	1	134.3	6.21	0.86	1	1	128.7	7.11	0.88	1	1	123.5	8.13	0.9	1	1
67°F	4000	134.7	5.37	0.59	0.73	0.86	129.8	6.18	0.6	0.74	0.87	123.6	7.07	0.6	0.75	0.89	118.7	8.08	0.61	0.77	0.91
	5000	140.8	5.4	0.62	0.78	0.93	135.2	6.22	0.63	0.79	0.94	128.9	7.12	0.64	0.81	0.96	123.2	8.14	0.65	0.83	0.98
	6000	145.3	5.43	0.66	0.83	0.97	139.1	6.26	0.67	0.85	0.99	133.1	7.17	0.68	0.86	0.99	126.5	8.17	0.69	0.89	1
71°F	4000	140.8	5.39	0.45	0.58	0.71	135.8	6.21	0.45	0.59	0.72	129.6	7.12	0.45	0.59	0.73	124.2	8.14	0.45	0.6	0.75
	5000	148	5.44	0.46	0.62	0.76	141.8	6.27	0.46	0.63	0.78	135.8	7.19	0.46	0.63	0.79	129.3	8.2	0.47	0.65	0.81
	6000	152.7	5.47	0.47	0.65	0.81	145.9	6.31	0.48	0.66	0.83	139.7	7.23	0.48	0.67	0.85	133.5	8.26	0.48	0.68	0.87

NOTE - Compressors operating at maximum capacity.

## 25 TON - LGM300U5M/V (THREE COMPRESSORS OPERATING)

Entering Wet Bulb Temperature	Total Air Volume	Outdoor Air Temperature Entering Outdoor Coil																			
		85°F					95°F					105°F					115°F				
		Total Cool Cap.	Comp. Motor Input	Sensible To Total Ratio (S/T)			Total Cool Cap.	Comp. Motor Input	Sensible To Total Ratio (S/T)			Total Cool Cap.	Comp. Motor Input	Sensible To Total Ratio (S/T)			Total Cool Cap.	Comp. Motor Input	Sensible To Total Ratio (S/T)		
				Dry Bulb					Dry Bulb					Dry Bulb					Dry Bulb		
cfm	kBtuh	kW	75°F	80°F	85°F	kBtuh	kW	75°F	80°F	85°F	kBtuh	kW	75°F	80°F	85°F	kBtuh	kW	75°F	80°F	85°F	
63°F	5600	192.9	11.98	0.78	0.9	0.96	184.8	13.65	0.8	0.91	0.97	176.7	15.55	0.82	0.92	0.97	167.3	17.68	0.83	0.93	0.98
	7000	203.5	12.1	0.83	0.94	0.98	194.4	13.78	0.85	0.94	0.99	185.4	15.68	0.85	0.95	0.99	175.7	17.83	0.87	0.96	1
	8400	211.1	12.2	0.87	0.96	1	201.9	13.9	0.88	0.96	1	192.4	15.79	0.9	0.97	1	182.9	17.94	0.91	0.98	1
67°F	5600	201.7	12.09	0.54	0.73	0.87	193	13.78	0.54	0.74	0.89	183.2	15.66	0.55	0.77	0.9	173.5	17.81	0.57	0.78	0.91
	7000	210.1	12.2	0.57	0.81	0.92	200.6	13.89	0.58	0.82	0.93	190.9	15.79	0.59	0.83	0.94	180.2	17.93	0.61	0.86	0.95
	8400	216.1	12.27	0.63	0.85	0.94	207.2	13.99	0.64	0.87	0.95	196.8	15.89	0.66	0.88	0.96	186.5	18.04	0.67	0.9	0.97
71°F	5600	212.9	12.22	0.33	0.5	0.68	204	13.93	0.33	0.51	0.7	193.8	15.83	0.31	0.52	0.72	183.4	17.99	0.33	0.54	0.75
	7000	221.4	12.34	0.33	0.55	0.75	211.6	14.06	0.34	0.56	0.77	201	15.96	0.33	0.58	0.8	189.5	18.11	0.34	0.6	0.82
	8400	228.2	12.44	0.35	0.6	0.82	218	14.17	0.35	0.61	0.84	205.9	16.05	0.36	0.63	0.87	194.7	18.22	0.37	0.65	0.88

NOTE - Compressors operating at maximum capacity.

## 25 TON - LGM300U5M/V (FOUR COMPRESSORS OPERATING)

Entering Wet Bulb Temperature	Total Air Volume	Outdoor Air Temperature Entering Outdoor Coil																			
		85°F					95°F					105°F					115°F				
		Total Cool Cap.	Comp. Motor Input	Sensible To Total Ratio (S/T)			Total Cool Cap.	Comp. Motor Input	Sensible To Total Ratio (S/T)			Total Cool Cap.	Comp. Motor Input	Sensible To Total Ratio (S/T)			Total Cool Cap.	Comp. Motor Input	Sensible To Total Ratio (S/T)		
				Dry Bulb					Dry Bulb					Dry Bulb					Dry Bulb		
cfm	kBtuh	kW	75°F	80°F	85°F	kBtuh	kW	75°F	80°F	85°F	kBtuh	kW	75°F	80°F	85°F	kBtuh	kW	75°F	80°F	85°F	
63°F	7000	270.7	17.35	0.69	0.82	0.91	260.5	19.68	0.69	0.83	0.92	248.6	22.28	0.7	0.84	0.93	235.8	25.23	0.72	0.85	0.95
	8500	284.2	17.48	0.72	0.85	0.95	272.3	19.82	0.74	0.87	0.97	259.9	22.43	0.75	0.88	0.98	246.6	25.4	0.77	0.9	0.99
	10000	294.2	17.58	0.76	0.89	0.99	282.1	19.94	0.78	0.91	1	269.5	22.57	0.8	0.92	1	255.8	25.55	0.82	0.94	1
67°F	7000	282.7	17.47	0.54	0.66	0.79	270.1	19.8	0.53	0.66	0.8	260.3	22.45	0.54	0.69	0.81	246	25.41	0.55	0.71	0.83
	8500	296.4	17.63	0.56	0.71	0.83	283.6	19.98	0.56	0.72	0.84	270.7	22.61	0.56	0.73	0.86	255.5	25.57	0.57	0.76	0.87
	10000	305.6	17.72	0.58	0.75	0.87	292.1	20.09	0.59	0.77	0.88	277.8	22.72	0.59	0.78	0.9	263.9	25.71	0.6	0.79	0.92
71°F	7000	302.1	17.68	0.4	0.52	0.64	289.8	20.05	0.4	0.52	0.65	275.7	22.68	0.4	0.53	0.65	261.7	25.67	0.39	0.53	0.67
	8500	314.3	17.81	0.4	0.54	0.68	300.3	20.19	0.4	0.55	0.69	286	22.84	0.4	0.56	0.71	267.4	25.76	0.41	0.57	0.73
	10000	322.7	17.89	0.41	0.57	0.72	305.4	20.25	0.42	0.58	0.74	293.5	22.96	0.41	0.6	0.76	276.8	25.95	0.42	0.61	0.78

NOTE - Compressors operating at maximum capacity.

# HUMIDITROL™ + DEHUMIDIFICATION SYSTEM RATINGS

## 13 TON - HIGH EFFICIENCY LGM156U5M WITH HUMIDITROL® (COMPRESSOR 1-2 IN REHEAT)

Entering Wet Bulb Temperature	Total Air Volume	Outdoor Air Temperature Entering Outdoor Coil																			
		65°F					75°F					85°F					95°F				
		Total Cool Cap.	Comp. Motor Input	Sensible To Total Ratio (S/T)			Total Cool Cap.	Comp. Motor Input	Sensible To Total Ratio (S/T)			Total Cool Cap.	Comp. Motor Input	Sensible To Total Ratio (S/T)			Total Cool Cap.	Comp. Motor Input	Sensible To Total Ratio (S/T)		
				Dry Bulb					Dry Bulb					Dry Bulb					Dry Bulb		
cfm	kBtuh	kW	75°F	80°F	85°F	kBtuh	kW	75°F	80°F	85°F	kBtuh	kW	75°F	80°F	85°F	kBtuh	kW	75°F	80°F	85°F	
63°F	1788	52.1	3.74	0.44	0.58	0.72	39.8	4.26	0.33	0.54	0.71	29.0	4.81	0.15	0.39	0.67	16.9	5.40	0.61	0.19	0.56
	1950	54.6	3.73	0.45	0.60	0.74	41.8	4.26	0.43	0.58	0.71	29.8	4.81	0.37	0.51	0.66	17.1	5.39	0.63	0.41	0.59
	2113	57.1	3.71	0.46	0.61	0.76	43.8	4.26	0.53	0.62	0.71	30.6	4.82	0.59	0.63	0.66	17.3	5.37	0.65	0.64	0.62
67°F	1788	61.4	3.73	0.29	0.43	0.57	48.9	4.27	0.17	0.35	0.52	37.0	4.81	0.14	0.23	0.45	25.1	5.44	0.56	0.19	0.29
	1950	63.6	3.71	0.29	0.44	0.59	50.6	4.26	0.29	0.41	0.52	37.8	4.82	0.33	0.35	0.44	25.1	5.42	0.59	0.34	0.32
	2113	65.8	3.69	0.30	0.45	0.61	52.2	4.26	0.40	0.46	0.52	38.7	4.83	0.51	0.47	0.44	25.1	5.39	0.61	0.48	0.35
71°F	1788	71.5	3.72	0.18	0.30	0.43	58.9	4.26	0.07	0.21	0.36	46.0	4.82	0.21	0.08	0.27	33.9	5.47	0.58	0.27	0.09
	1950	73.3	3.71	0.18	0.31	0.44	60.2	4.26	0.21	0.28	0.35	46.9	4.83	0.35	0.22	0.25	34.1	5.44	0.61	0.33	0.11
	2113	75.1	3.69	0.19	0.32	0.45	61.5	4.27	0.34	0.34	0.34	47.9	4.84	0.49	0.36	0.23	34.3	5.42	0.65	0.38	0.12

NOTE - Total Cooling Capacity is calculated at 80°F Dry Bulb.

## 13 TON - HIGH EFFICIENCY LGM156U5M WITH HUMIDITROL® (COMPRESSOR 1-2 IN REHEAT , COMPRESSOR 3 ON)

Entering Wet Bulb Temperature	Total Air Volume	Outdoor Air Temperature Entering Outdoor Coil																			
		65°F					75°F					85°F					95°F				
		Total Cool Cap.	Comp. Motor Input	Sensible To Total Ratio (S/T)			Total Cool Cap.	Comp. Motor Input	Sensible To Total Ratio (S/T)			Total Cool Cap.	Comp. Motor Input	Sensible To Total Ratio (S/T)			Total Cool Cap.	Comp. Motor Input	Sensible To Total Ratio (S/T)		
				Dry Bulb					Dry Bulb					Dry Bulb					Dry Bulb		
cfm	kBtuh	kW	75°F	80°F	85°F	kBtuh	kW	75°F	80°F	85°F	kBtuh	kW	75°F	80°F	85°F	kBtuh	kW	75°F	80°F	85°F	
63°F	3575	105.2	5.58	0.52	0.68	0.80	84.8	6.37	0.48	0.67	0.83	65.0	7.28	0.40	0.66	0.82	48.0	8.25	0.23	0.54	0.78
	3900	109.3	5.56	0.54	0.69	0.82	88.6	6.41	0.47	0.66	0.82	68.3	7.31	0.39	0.63	0.81	49.3	8.24	0.25	0.54	0.79
	4225	113.4	5.55	0.56	0.70	0.84	92.4	6.45	0.47	0.64	0.82	71.5	7.34	0.37	0.59	0.81	50.5	8.23	0.28	0.54	0.80
67°F	3575	118.8	5.58	0.36	0.51	0.65	98.5	6.37	0.30	0.48	0.63	78.4	7.29	0.20	0.41	0.61	60.2	8.26	0.14	0.31	0.54
	3900	123.0	5.56	0.37	0.52	0.67	102.1	6.40	0.29	0.47	0.64	81.3	7.31	0.19	0.41	0.62	61.4	8.25	0.11	0.32	0.57
	4225	127.3	5.53	0.38	0.53	0.68	105.7	6.43	0.28	0.47	0.65	84.2	7.33	0.18	0.40	0.63	62.6	8.23	0.08	0.34	0.60
71°F	3575	134.4	5.57	0.24	0.37	0.50	130.4	6.36	0.16	0.32	0.46	91.6	7.29	0.10	0.23	0.41	71.0	8.28	0.19	0.11	0.32
	3900	136.6	5.55	0.27	0.39	0.51	123.5	6.40	0.22	0.35	0.47	93.2	7.32	0.18	0.28	0.42	71.9	8.27	0.20	0.20	0.34
	4225	138.7	5.54	0.31	0.42	0.53	116.7	6.44	0.28	0.38	0.47	94.8	7.35	0.25	0.33	0.42	72.8	8.25	0.22	0.29	0.36

NOTE - Total Cooling Capacity is calculated at 80°F Dry Bulb.

## 15 TON - HIGH EFFICIENCY LGM180U5M WITH HUMIDITROL® (COMPRESSOR 1-2 IN REHEAT)

Entering Wet Bulb Temperature	Total Air Volume	Outdoor Air Temperature Entering Outdoor Coil																			
		65°F					75°F					85°F					95°F				
		Total Cool Cap.	Comp. Motor Input	Sensible To Total Ratio (S/T)			Total Cool Cap.	Comp. Motor Input	Sensible To Total Ratio (S/T)			Total Cool Cap.	Comp. Motor Input	Sensible To Total Ratio (S/T)			Total Cool Cap.	Comp. Motor Input	Sensible To Total Ratio (S/T)		
				Dry Bulb					Dry Bulb					Dry Bulb					Dry Bulb		
cfm	kBtuh	kW	75°F	80°F	85°F	kBtuh	kW	75°F	80°F	85°F	kBtuh	kW	75°F	80°F	85°F	kBtuh	kW	75°F	80°F	85°F	
63°F	2063	62.4	4.44	0.42	0.59	0.73	49.0	5.00	0.33	0.53	0.70	36.6	5.61	0.16	0.44	0.65	23.5	6.30	0.35	0.24	0.55
	2250	65.0	4.43	0.44	0.60	0.75	51.1	5.02	0.38	0.55	0.71	37.6	5.63	0.28	0.49	0.67	23.8	6.28	0.36	0.37	0.60
	2438	67.6	4.42	0.45	0.61	0.76	53.1	5.03	0.42	0.57	0.73	38.6	5.65	0.39	0.54	0.69	24.1	6.26	0.36	0.50	0.65
67°F	2063	73.5	4.45	0.28	0.43	0.55	59.8	5.02	0.18	0.35	0.52	46.7	5.65	0.06	0.22	0.44	32.8	6.32	0.41	0.09	0.31
	2250	76.0	4.43	0.29	0.44	0.57	61.7	5.03	0.26	0.39	0.52	47.6	5.66	0.22	0.32	0.44	33.2	6.31	0.42	0.25	0.35
	2438	78.5	4.42	0.30	0.44	0.59	63.5	5.05	0.34	0.43	0.52	48.5	5.67	0.38	0.42	0.45	33.5	6.29	0.43	0.40	0.38
71°F	2063	84.4	4.46	0.17	0.29	0.41	71.4	5.04	0.06	0.21	0.36	57.2	5.69	0.16	0.08	0.27	43.6	6.39	0.46	0.19	0.12
	2250	87.3	4.45	0.17	0.30	0.43	73.0	5.06	0.17	0.26	0.35	58.1	5.71	0.28	0.20	0.26	43.6	6.38	0.49	0.26	0.13
	2438	90.1	4.43	0.17	0.31	0.44	74.6	5.07	0.29	0.32	0.34	59.1	5.72	0.40	0.33	0.25	43.5	6.37	0.52	0.34	0.15

NOTE - Total Cooling Capacity is calculated at 80°F Dry Bulb.

## 15 TON HIGH EFFICIENCY LGM180U5M WITH HUMIDITROL® (COMPRESSOR 1-2 IN REHEAT , COMPRESSOR 3 ON)

Entering Wet Bulb Temperature	Total Air Volume	Outdoor Air Temperature Entering Outdoor Coil																			
		65°F					75°F					85°F					95°F				
		Total Cool Cap.	Comp. Motor Input	Sensible To Total Ratio (S/T)			Total Cool Cap.	Comp. Motor Input	Sensible To Total Ratio (S/T)			Total Cool Cap.	Comp. Motor Input	Sensible To Total Ratio (S/T)			Total Cool Cap.	Comp. Motor Input	Sensible To Total Ratio (S/T)		
				Dry Bulb					Dry Bulb					Dry Bulb					Dry Bulb		
cfm	kBtuh	kW	75°F	80°F	85°F	kBtuh	kW	75°F	80°F	85°F	kBtuh	kW	75°F	80°F	85°F	kBtuh	kW	75°F	80°F	85°F	
63°F	4125	121.0	6.67	0.52	0.68	0.81	101.6	7.59	0.47	0.66	0.82	81.0	8.62	0.40	0.64	0.82	59.9	9.74	0.27	0.59	0.83
	4500	125.4	6.67	0.54	0.69	0.83	104.7	7.64	0.48	0.66	0.83	83.3	8.66	0.40	0.63	0.83	61.6	9.73	0.30	0.59	0.84
	4875	129.9	6.67	0.55	0.70	0.84	107.7	7.69	0.48	0.66	0.85	85.5	8.70	0.40	0.63	0.85	63.3	9.72	0.33	0.59	0.85
67°F	4125	137.6	6.68	0.36	0.50	0.65	117.4	7.62	0.30	0.47	0.63	96.5	8.66	0.20	0.41	0.61	75.4	9.81	0.05	0.32	0.55
	4500	141.7	6.68	0.38	0.52	0.67	120.3	7.67	0.29	0.47	0.65	98.6	8.71	0.19	0.41	0.62	76.8	9.80	0.07	0.33	0.58
	4875	145.9	6.69	0.39	0.54	0.69	123.3	7.72	0.29	0.48	0.67	100.7	8.75	0.18	0.41	0.64	78.2	9.78	0.08	0.35	0.62
71°F	4125	154.8	6.71	0.23	0.37	0.49	134.7	7.66	0.16	0.32	0.46	111.1	8.69	0.07	0.24	0.41	88.9	9.88	0.18	0.13	0.34
	4500	158.3	6.71	0.24	0.38	0.51	136.8	7.71	0.20	0.34	0.47	113.5	8.75	0.14	0.28	0.42	90.9	9.86	0.19	0.21	0.36
	4875	161.8	6.71	0.26	0.39	0.53	138.9	7.76	0.24	0.36	0.48	115.9	8.80	0.22	0.33	0.43	92.9	9.85	0.20	0.29	0.39

NOTE - Total Cooling Capacity is calculated at 80°F Dry Bulb.

# HUMIDITROL™ + DEHUMIDIFICATION SYSTEM RATINGS

## 17.5 TON - HIGH EFFICIENCY LGM210U5M WITH HUMIDITROL® (COMPRESSOR 1-2 IN REHEAT)

Entering Wet Bulb Temperature	Total Air Volume	Outdoor Air Temperature Entering Outdoor Coil																			
		65°F					75°F					85°F					95°F				
		Total Cool Cap.	Comp. Motor Input	Sensible To Total Ratio (S/T)			Total Cool Cap.	Comp. Motor Input	Sensible To Total Ratio (S/T)			Total Cool Cap.	Comp. Motor Input	Sensible To Total Ratio (S/T)			Total Cool Cap.	Comp. Motor Input	Sensible To Total Ratio (S/T)		
				Dry Bulb					Dry Bulb					Dry Bulb					Dry Bulb		
cfm	kBtuh	kW	75°F	80°F	85°F	kBtuh	kW	75°F	80°F	85°F	kBtuh	kW	75°F	80°F	85°F	kBtuh	kW	75°F	80°F	85°F	
63°F	2406	47.3	4.54	0.41	0.67	0.90	47.7	4.39	0.41	0.70	0.92	36.9	4.84	0.33	0.71	0.88	23.4	5.50	-0.03	0.53	0.89
	2625	49.0	4.49	0.44	0.69	0.93	44.5	4.58	0.37	0.68	0.96	34.6	4.97	0.26	0.67	0.97	23.2	5.47	0.02	0.56	1.00
	2844	50.6	4.44	0.47	0.71	0.96	41.4	4.77	0.33	0.67	1.01	32.2	5.10	0.20	0.63	1.06	23.0	5.43	0.07	0.59	1.11
67°F	2406	66.5	4.12	0.30	0.48	0.67	60.1	4.32	0.25	0.46	0.66	47.9	4.85	0.11	0.34	0.61	33.3	5.53	-0.21	0.15	0.54
	2625	68.5	4.08	0.32	0.50	0.69	59.2	4.42	0.20	0.44	0.67	46.9	4.92	0.04	0.33	0.63	33.5	5.50	-0.20	0.18	0.58
	2844	70.6	4.04	0.34	0.53	0.71	58.3	4.51	0.16	0.42	0.68	46.0	4.99	-0.02	0.32	0.65	33.7	5.46	-0.19	0.22	0.62
71°F	2406	86.4	3.70	0.22	0.37	0.51	72.2	4.29	0.09	0.28	0.48	59.3	4.85	-0.04	0.18	0.39	45.5	5.50	-0.33	-0.02	0.25
	2625	89.3	3.65	0.22	0.38	0.54	74.4	4.26	0.06	0.27	0.48	60.1	4.85	-0.10	0.15	0.39	45.4	5.49	-0.35	-0.02	0.28
	2844	92.1	3.60	0.23	0.40	0.57	76.5	4.23	0.03	0.26	0.48	60.9	4.85	-0.17	0.12	0.40	45.2	5.48	-0.37	-0.03	0.31

NOTE - Total Cooling Capacity is calculated at 80°F Dry Bulb.

## 17.5 TON - HIGH EFFICIENCY LGM210U5M WITH HUMIDITROL® (COMPRESSOR 1-2 IN REHEAT, COMPRESSOR 3-4 ON)

Entering Wet Bulb Temperature	Total Air Volume	Outdoor Air Temperature Entering Outdoor Coil																			
		65°F					75°F					85°F					95°F				
		Total Cool Cap.	Comp. Motor Input	Sensible To Total Ratio (S/T)			Total Cool Cap.	Comp. Motor Input	Sensible To Total Ratio (S/T)			Total Cool Cap.	Comp. Motor Input	Sensible To Total Ratio (S/T)			Total Cool Cap.	Comp. Motor Input	Sensible To Total Ratio (S/T)		
				Dry Bulb					Dry Bulb					Dry Bulb					Dry Bulb		
cfm	kBtuh	kW	75°F	80°F	85°F	kBtuh	kW	75°F	80°F	85°F	kBtuh	kW	75°F	80°F	85°F	kBtuh	kW	75°F	80°F	85°F	
63°F	4813	135.3	8.17	0.54	0.71	0.85	115.1	9.27	0.51	0.71	0.87	96.5	10.43	0.47	0.71	0.88	87.3	11.43	0.43	0.69	0.88
	5250	139.2	8.15	0.55	0.72	0.88	120.5	9.25	0.53	0.72	0.89	102.5	10.37	0.49	0.71	0.90	89.3	11.41	0.46	0.70	0.90
	5688	143.1	8.14	0.57	0.74	0.90	125.9	9.22	0.54	0.73	0.91	108.6	10.31	0.52	0.72	0.92	91.3	11.39	0.49	0.71	0.92
67°F	4813	151.9	8.34	0.35	0.52	0.66	132.2	9.41	0.31	0.49	0.66	128.9	10.06	0.30	0.51	0.67	105.5	11.48	0.22	0.46	0.65
	5250	155.7	8.33	0.37	0.53	0.69	137.3	9.38	0.32	0.51	0.69	127.1	10.22	0.29	0.51	0.70	106.8	11.45	0.23	0.47	0.69
	5688	159.6	8.32	0.38	0.55	0.71	142.4	9.35	0.34	0.53	0.72	125.3	10.39	0.29	0.51	0.73	108.1	11.42	0.24	0.49	0.73
71°F	4813	175.5	8.30	0.23	0.37	0.51	170.6	8.82	0.23	0.38	0.52	151.2	9.96	0.16	0.33	0.49	127.1	11.46	0.07	0.26	0.50
	5250	181.4	8.25	0.23	0.38	0.53	168.7	9.05	0.20	0.37	0.52	148.7	10.16	0.14	0.32	0.49	126.5	11.46	0.07	0.26	0.48
	5688	187.3	8.19	0.23	0.39	0.56	166.8	9.28	0.18	0.35	0.52	146.3	10.37	0.12	0.30	0.49	125.8	11.46	0.06	0.26	0.46

NOTE - Total Cooling Capacity is calculated at 80°F Dry Bulb.

## 20 TON - HIGH EFFICIENCY LGM240U5M WITH HUMIDITROL® (COMPRESSOR 1-2 IN REHEAT)

Entering Wet Bulb Temperature	Total Air Volume	Outdoor Air Temperature Entering Outdoor Coil																			
		65°F					75°F					85°F					95°F				
		Total Cool Cap.	Comp. Motor Input	Sensible To Total Ratio (S/T)			Total Cool Cap.	Comp. Motor Input	Sensible To Total Ratio (S/T)			Total Cool Cap.	Comp. Motor Input	Sensible To Total Ratio (S/T)			Total Cool Cap.	Comp. Motor Input	Sensible To Total Ratio (S/T)		
				Dry Bulb					Dry Bulb					Dry Bulb					Dry Bulb		
cfm	kBtuh	kW	75°F	80°F	85°F	kBtuh	kW	75°F	80°F	85°F	kBtuh	kW	75°F	80°F	85°F	kBtuh	kW	75°F	80°F	85°F	
63°F	2750	58.1	5.83	0.40	0.65	0.86	58.8	5.68	0.40	0.65	0.84	44.3	6.19	0.30	0.66	0.89	29.5	6.96	1.04	0.48	0.86
	3000	61.7	5.77	0.42	0.66	0.88	56.0	5.90	0.36	0.63	0.88	42.7	6.36	0.25	0.61	0.91	29.3	6.96	0.56	0.50	0.91
	3250	65.3	5.70	0.44	0.67	0.90	53.3	6.12	0.32	0.62	0.92	41.2	6.54	0.20	0.57	0.93	29.1	6.95	0.08	0.52	0.95
67°F	2750	81.3	5.33	0.28	0.47	0.64	74.5	5.59	0.22	0.43	0.62	57.7	6.23	0.10	0.35	0.59	41.5	7.04	1.25	0.15	0.50
	3000	85.1	5.27	0.30	0.48	0.66	73.7	5.70	0.42	0.54	0.64	57.3	6.32	0.51	0.57	0.61	41.2	7.03	1.24	0.54	0.56
	3250	88.8	5.20	0.31	0.50	0.69	72.8	5.80	0.61	0.64	0.67	56.9	6.41	0.91	0.78	0.64	40.9	7.02	1.22	0.92	0.62
71°F	2750	105.4	4.78	0.21	0.36	0.49	87.7	5.63	0.09	0.27	0.43	71.4	6.27	1.05	0.17	0.37	42.5	7.13	1.00	1.03	0.24
	3000	107.5	4.83	0.20	0.36	0.51	86.6	5.62	0.27	0.36	0.44	66.4	6.31	0.89	0.36	0.37	39.9	7.11	1.00	0.84	0.27
	3250	109.5	4.88	0.19	0.36	0.53	85.5	5.62	0.46	0.46	0.45	61.5	6.35	0.73	0.55	0.38	37.4	7.09	1.00	0.65	0.30

NOTE - Total Cooling Capacity is calculated at 80°F Dry Bulb.

## 20 TON - HIGH EFFICIENCY LGM240U5M WITH HUMIDITROL® (COMPRESSOR 1-2 IN REHEAT, COMPRESSOR 3-4 ON)

Entering Wet Bulb Temperature	Total Air Volume	Outdoor Air Temperature Entering Outdoor Coil																			
		65°F					75°F					85°F					95°F				
		Total Cool Cap.	Comp. Motor Input	Sensible To Total Ratio (S/T)			Total Cool Cap.	Comp. Motor Input	Sensible To Total Ratio (S/T)			Total Cool Cap.	Comp. Motor Input	Sensible To Total Ratio (S/T)			Total Cool Cap.	Comp. Motor Input	Sensible To Total Ratio (S/T)		
				Dry Bulb					Dry Bulb					Dry Bulb					Dry Bulb		
cfm	kBtuh	kW	75°F	80°F	85°F	kBtuh	kW	75°F	80°F	85°F	kBtuh	kW	75°F	80°F	85°F	kBtuh	kW	75°F	80°F	85°F	
63°F	5500	160.7	10.46	0.51	0.67	0.80	129.3	11.74	0.50	0.68	0.85	109.6	12.99	0.46	0.70	0.86	98.6	14.09	0.45	0.67	0.89
	6000	161.1	10.42	0.54	0.70	0.84	135.6	11.68	0.52	0.70	0.88	115.9	12.91	0.49	0.71	0.89	100.6	14.07	0.47	0.69	0.91
	6500	161.5	10.39	0.57	0.72	0.88	141.9	11.61	0.54	0.72	0.90	122.2	12.84	0.51	0.71	0.91	102.6	14.06	0.49	0.71	0.93
67°F	5500	177.5	10.65	0.33	0.49	0.63	151.7	11.80	0.29	0.49	0.66	144.4	12.56	0.30	0.50	0.67	119.3	14.16	0.21	0.45	0.66
	6000	178.5	10.61	0.35	0.51	0.66	156.0	11.78	0.31	0.50	0.68	142.8	12.75	0.29	0.50	0.69	120.7	14.15	0.23	0.46	0.69
	6500	179.4	10.57	0.37	0.53	0.69	160.3	11.76	0.33	0.51	0.70	141.2	12.95	0.29	0.50	0.71	122.1	14.13	0.24	0.48	0.72
71°F	5500	204.3	10.48	0.21	0.36	0.49	195.9	11.03	0.22	0.37	0.51	171.4	12.47	0.16	0.33	0.49	140.5	14.27	0.06	0.26	0.45
	6000	212.3	10.23	0.23	0.38	0.52	195.5	11.22	0.20	0.37	0.52	170.6	12.65	0.14	0.32	0.50	142.5	14.25	0.05	0.26	0.47
	6500	220.4	9.98	0.26	0.41	0.56	195.1	11.40	0.19	0.36	0.53	169.8	12.82	0.11	0.31	0.51	144.5	14.24	0.04	0.27	0.49

NOTE - Total Cooling Capacity is calculated at 80°F Dry Bulb.

# HUMIDITROL™ + DEHUMIDIFICATION SYSTEM RATINGS

## 25 TON - HIGH EFFICIENCY LGM300U5M WITH HUMIDITROL® (COMPRESSOR 1-2 IN REHEAT)

Entering Wet Bulb Temperature	Total Air Volume	Outdoor Air Temperature Entering Outdoor Coil																				
		65°F						75°F					85°F					95°F				
		Total Cool Cap.	Comp. Motor Input	Sensible To Total Ratio (S/T)			Total Cool Cap.	Comp. Motor Input	Sensible To Total Ratio (S/T)			Total Cool Cap.	Comp. Motor Input	Sensible To Total Ratio (S/T)			Total Cool Cap.	Comp. Motor Input	Sensible To Total Ratio (S/T)			
				Dry Bulb					Dry Bulb					Dry Bulb					Dry Bulb			
cfm	kBtuh	kW	75°F	80°F	85°F	kBtuh	kW	75°F	80°F	85°F	kBtuh	kW	75°F	80°F	85°F	kBtuh	kW	75°F	80°F	85°F		
63°F	3438	58.1	5.8	0.40	0.65	0.86	58.8	5.7	0.40	0.65	0.84	44.3	6.2	0.30	0.66	0.89	29.5	7.0	1.04	0.48	0.86	
	3750	61.7	5.8	0.42	0.66	0.88	56.0	5.9	0.36	0.63	0.88	42.7	6.4	0.25	0.61	0.91	29.3	6.96	0.56	0.50	0.91	
	4063	65.3	5.7	0.44	0.67	0.90	53.3	6.1	0.32	0.62	0.92	41.2	6.5	0.20	0.57	0.93	29.1	7.0	0.08	0.52	0.95	
67°F	3438	81.3	5.3	0.28	0.47	0.64	74.5	5.6	0.22	0.43	0.62	57.7	6.2	0.10	0.35	0.59	41.5	7.0	1.25	0.15	0.50	
	3750	85.1	5.3	0.30	0.48	0.66	73.7	5.7	0.42	0.54	0.64	57.3	6.3	0.51	0.57	0.61	41.2	7.03	1.24	0.54	0.56	
	4063	88.8	5.2	0.31	0.50	0.69	72.8	5.8	0.61	0.64	0.67	56.9	6.4	0.91	0.78	0.64	40.9	7.0	1.22	0.92	0.62	
71°F	3438	105.4	4.8	0.21	0.36	0.49	87.7	5.6	0.09	0.27	0.43	71.4	6.3	1.05	0.17	0.37	42.5	7.1	1.00	1.03	0.24	
	3750	107.5	4.8	0.20	0.36	0.51	86.6	5.6	0.27	0.36	0.44	66.4	6.3	0.89	0.36	0.37	39.9	7.11	1.00	0.84	0.27	
	4063	109.5	4.9	0.19	0.36	0.53	85.5	5.6	0.46	0.46	0.45	61.5	6.4	0.73	0.55	0.38	37.4	7.1	1.00	0.65	0.30	

NOTE - Total Cooling Capacity is calculated at 80°F Dry Bulb.

## 25 TON - HIGH EFFICIENCY LGM300U5M WITH HUMIDITROL® (COMPRESSOR 1-2 IN REHEAT, COMPRESSOR 3-4 ON)

Entering Wet Bulb Temperature	Total Air Volume	Outdoor Air Temperature Entering Outdoor Coil																				
		65°F						75°F					85°F					95°F				
		Total Cool Cap.	Comp. Motor Input	Sensible To Total Ratio (S/T)			Total Cool Cap.	Comp. Motor Input	Sensible To Total Ratio (S/T)			Total Cool Cap.	Comp. Motor Input	Sensible To Total Ratio (S/T)			Total Cool Cap.	Comp. Motor Input	Sensible To Total Ratio (S/T)			
				Dry Bulb					Dry Bulb					Dry Bulb					Dry Bulb			
cfm	kBtuh	kW	75°F	80°F	85°F	kBtuh	kW	75°F	80°F	85°F	kBtuh	kW	75°F	80°F	85°F	kBtuh	kW	75°F	80°F	85°F		
63°F	6875	192.5	13.7	0.54	0.71	0.84	160.9	15.3	0.53	0.72	0.89	136.9	16.9	0.50	0.72	0.91	126.8	18.4	0.45	0.72	0.89	
	7500	196.4	13.7	0.56	0.72	0.87	168.9	15.3	0.55	0.73	0.90	145.3	16.9	0.53	0.73	0.91	128.5	18.37	0.49	0.73	0.90	
	8125	200.3	13.7	0.58	0.74	0.90	177.0	15.2	0.57	0.74	0.91	153.6	16.8	0.55	0.73	0.92	130.3	18.4	0.54	0.73	0.92	
67°F	6875	212.7	13.9	0.36	0.52	0.67	181.9	15.7	0.32	0.50	0.70	173.8	16.8	0.30	0.49	0.70	153.7	18.4	0.26	0.49	0.68	
	7500	217.1	13.9	0.37	0.54	0.70	190.8	15.5	0.33	0.52	0.71	175.9	16.9	0.31	0.51	0.71	155.0	18.42	0.27	0.50	0.71	
	8125	221.4	13.9	0.38	0.55	0.72	199.7	15.4	0.35	0.54	0.73	178.0	16.9	0.31	0.52	0.73	156.3	18.4	0.28	0.51	0.74	
71°F	6875	241.0	14.1	0.21	0.36	0.51	234.4	15.0	0.23	0.37	0.53	213.1	16.5	0.18	0.36	0.51	179.6	18.6	0.08	0.30	0.48	
	7500	250.0	13.9	0.22	0.38	0.53	233.0	15.2	0.21	0.37	0.54	208.6	16.8	0.16	0.35	0.53	178.2	18.63	0.08	0.30	0.51	
	8125	259.1	13.8	0.23	0.39	0.55	231.6	15.4	0.18	0.37	0.55	204.1	17.0	0.13	0.34	0.55	176.7	18.7	0.08	0.31	0.55	

NOTE - Total Cooling Capacity is calculated at 80°F Dry Bulb.

## BLOWER DATA

BLOWER TABLE INCLUDES RESISTANCE FOR BASE UNIT ONLY WITH DRY INDOOR COIL & AIR FILTERS IN PLACE FOR ALL UNITS ADD:

- 1 - Wet indoor coil air resistance of selected unit.
- 2 - Any factory installed options air resistance (heat section, Economizer, etc.)
- 3 - Any field installed accessories air resistance (heat section, duct resistance, diffuser, etc.)

Then determine from blower table blower motor output and drive required.  
See page 39 for wet coil and option/accessory air resistance data.  
See page 39 for factory installed drive kit specifications.

### MINIMUM AIR VOLUME REQUIRED FOR DIFFERENT GAS HEAT SIZES

Low Heat - 3000 cfm | Standard and Medium Heat - 4500 cfm | High Heat - 5125 cfm

#### TOTAL STATIC PRESSURE - Inches Water Gauge (Pa)

Air Volume cfm	0.20		0.40		0.60		0.80		1.00		1.20		1.40		1.60		1.80		2.00		2.20		2.40		2.60			
	RPM	BHP	RPM	BHP	RPM	BHP	RPM	BHP	RPM	BHP	RPM	BHP	RPM	BHP	RPM	BHP	RPM	BHP	RPM	BHP	RPM	BHP	RPM	BHP	RPM	BHP		
2750	385	0.30	505	0.50	600	0.70	680	0.90	755	1.10	820	1.30	885	1.50	950	1.70	1005	1.90	1060	2.10	1115	2.30	1170	2.50	1225	2.70	1280	2.90
3000	395	0.35	515	0.55	610	0.75	685	1.00	760	1.20	825	1.45	890	1.65	955	1.85	1015	2.05	1070	2.25	1130	2.45	1185	2.65	1240	2.85	1295	3.05
3250	405	0.40	520	0.60	615	0.85	695	1.10	775	1.30	830	1.60	895	1.80	960	2.00	1020	2.20	1080	2.40	1140	2.60	1200	2.80	1260	3.00	1320	3.20
3500	415	0.45	530	0.70	620	0.95	700	1.20	785	1.40	845	1.70	905	1.90	970	2.10	1030	2.30	1090	2.50	1150	2.70	1210	2.90	1270	3.10	1330	3.30
3750	425	0.50	540	0.75	630	1.05	710	1.30	795	1.50	855	1.85	915	2.05	980	2.25	1040	2.45	1100	2.65	1160	2.85	1220	3.05	1280	3.25	1340	3.45
4000	435	0.55	545	0.85	635	1.10	715	1.40	785	1.60	845	1.95	905	2.15	970	2.35	1030	2.55	1090	2.75	1150	2.95	1210	3.15	1270	3.35	1330	3.55
4250	445	0.60	555	0.90	645	1.25	725	1.55	795	1.75	855	2.15	915	2.35	980	2.55	1040	2.75	1100	2.95	1160	3.15	1220	3.35	1280	3.55	1340	3.75
4500	455	0.70	565	1.00	655	1.35	730	1.65	800	1.85	860	2.25	920	2.45	985	2.65	1045	2.85	1105	3.05	1165	3.25	1225	3.45	1285	3.65	1345	3.85
4750	470	0.75	575	1.10	660	1.45	740	1.80	810	2.05	870	2.45	930	2.65	995	2.85	1055	3.05	1115	3.25	1175	3.45	1235	3.65	1295	3.85	1355	4.05
5000	480	0.85	585	1.25	670	1.60	750	1.95	815	2.20	880	2.60	940	2.80	1005	3.00	1065	3.20	1125	3.40	1185	3.60	1245	3.80	1305	4.00	1365	4.20
5250	495	0.95	595	1.35	680	1.70	755	2.10	825	2.35	890	2.75	950	2.95	1015	3.15	1075	3.35	1135	3.55	1195	3.75	1255	3.95	1315	4.15	1375	4.35
5500	505	1.05	605	1.45	690	1.85	765	2.25	835	2.50	900	2.90	960	3.10	1025	3.30	1085	3.50	1145	3.70	1205	3.90	1265	4.10	1325	4.30	1385	4.50
5750	520	1.15	615	1.60	700	2.00	775	2.45	840	2.70	905	3.05	965	3.25	1030	3.45	1090	3.65	1150	3.85	1210	4.05	1270	4.25	1330	4.45	1390	4.65
6000	530	1.30	630	1.75	710	2.15	785	2.60	850	2.90	915	3.35	975	3.55	1040	3.75	1100	3.95	1160	4.15	1220	4.35	1280	4.55	1340	4.75	1400	4.95
6250	545	1.40	640	1.90	720	2.35	795	2.80	860	3.10	925	3.55	985	3.75	1050	3.95	1110	4.15	1170	4.35	1230	4.55	1290	4.75	1350	4.95	1410	5.15
6500	560	1.55	650	2.05	730	2.50	805	3.00	870	3.30	930	3.70	990	3.90	1055	4.10	1115	4.30	1175	4.50	1235	4.70	1295	4.90	1355	5.10	1415	5.30
6750	570	1.70	665	2.20	745	2.70	815	3.20	880	3.50	940	3.90	1000	4.10	1065	4.30	1125	4.50	1185	4.70	1245	4.90	1305	5.10	1365	5.30	1425	5.50
7000	585	1.85	675	2.35	755	2.90	825	3.40	890	3.70	950	4.10	1010	4.30	1075	4.50	1135	4.70	1195	4.90	1255	5.10	1315	5.30	1375	5.50	1435	5.70
7250	600	2.00	690	2.60	765	3.10	835	3.65	900	3.95	960	4.35	1020	4.55	1085	4.75	1145	4.95	1205	5.15	1265	5.35	1325	5.55	1385	5.75	1445	5.95
7500	615	2.20	700	2.75	775	3.30	845	3.85	910	4.15	970	4.55	1030	4.75	1095	4.95	1155	5.15	1215	5.35	1275	5.55	1335	5.75	1395	5.95	1455	6.15
7750	630	2.40	715	3.00	790	3.55	865	4.10	920	4.40	980	4.80	1040	5.00	1105	5.20	1165	5.40	1225	5.60	1285	5.80	1345	6.00	1405	6.20	1465	6.40
8000	640	2.55	725	3.20	800	3.80	865	4.35	930	4.65	990	5.05	1050	5.25	1115	5.45	1175	5.65	1235	5.85	1295	6.05	1355	6.25	1415	6.45	1475	6.65
8250	655	2.80	740	3.40	810	4.00	880	4.65	940	4.85	1000	5.25	1060	5.45	1120	5.65	1180	5.85	1240	6.05	1300	6.25	1360	6.45	1420	6.65	1480	6.85
8500	670	3.00	750	3.65	825	4.30	890	4.90	950	5.05	1010	5.45	1070	5.65	1130	5.85	1190	6.05	1250	6.25	1310	6.45	1370	6.65	1430	6.85	1490	7.05
8750	685	3.25	765	3.90	835	4.55	900	5.20	960	5.40	1020	5.65	1080	5.85	1140	6.05	1200	6.25	1260	6.45	1320	6.65	1380	6.85	1440	7.05	1500	7.25
9000	700	3.50	780	4.20	850	4.85	910	5.50	970	5.70	1030	5.95	1090	6.15	1150	6.35	1210	6.55	1270	6.75	1330	6.95	1390	7.15	1450	7.35	1510	7.55
9250	715	3.75	790	4.45	860	5.15	925	5.85	985	6.00	1040	6.25	1100	6.45	1160	6.65	1220	6.85	1280	7.05	1340	7.25	1400	7.45	1460	7.65	1520	7.85
9500	730	4.00	805	4.75	875	5.45	935	6.15	995	6.30	1050	6.55	1110	6.75	1170	6.95	1230	7.15	1290	7.35	1350	7.55	1410	7.75	1470	7.95	1530	8.15
9750	745	4.30	820	5.05	885	5.75	950	6.45	1005	6.55	1060	6.75	1120	6.95	1180	7.15	1240	7.35	1300	7.55	1360	7.75	1420	7.95	1480	8.15	1540	8.35
10,000	760	4.60	835	5.40	900	6.15	960	6.85	1015	6.85	1070	7.05	1130	7.25	1190	7.45	1250	7.65	1310	7.85	1370	8.05	1430	8.25	1490	8.45	1550	8.65
10,250	775	4.90	845	5.65	910	6.45	970	7.20	1030	7.05	1080	7.25	1140	7.45	1200	7.65	1260	7.85	1320	8.05	1380	8.25	1440	8.45	1500	8.65	1560	8.85
10,500	790	5.20	860	6.00	925	6.85	985	7.65	1040	7.45	1090	7.65	1150	7.85	1210	8.05	1270	8.25	1330	8.45	1390	8.65	1450	8.85	1510	9.05	1570	9.25
10,750	805	5.55	875	6.40	940	7.25	1000	8.05	1055	7.85	1105	8.05	1165	8.25	1220	8.45	1280	8.65	1340	8.85	1400	9.05	1460	9.25	1520	9.45	1580	9.65
11,000	820	5.90	890	6.80	950	7.60	1010	8.45	1065	8.25	1115	8.45	1175	8.65	1230	8.85	1290	9.05	1350	9.25	1410	9.45	1470	9.65	1530	9.85	1590	10.05

## BLOWER DATA

### FACTORY INSTALLED BELT DRIVE KIT SPECIFICATIONS

Nominal HP	Maximum HP	Drive Kit Number	RPM Range
3	3.45	1	535 - 725
3	3.45	2	710 - 965
5	5.75	3	685 - 856
5	5.75	4	850 - 1045
5	5.75	5	945 - 1185
7.5	8.63	6	850 - 1045
7.5	8.63	7	945 - 1185
7.5	8.63	8	1045 - 1285
10	11.50	7	945 - 1185
10	11.50	10	1045 - 1285
10	11.50	11	1135 - 1330

NOTE - Using total air volume and system static pressure requirements determine from blower performance tables rpm and motor output required. Maximum usable output of motors furnished are shown. In Canada, nominal motor output is also maximum usable motor output. If motors of comparable output are used, be sure to keep within the service factor limitations outlined on the motor nameplate.

NOTE - Blower motor service factor = 1.0.

### FACTORY INSTALLED OPTIONS/FIELD INSTALLED ACCESSORY AIR RESISTANCE in. w.g.

Air Volume cfm	Wet Indoor Coil		Reheat Coil	Gas Heat Exchanger			Economizer	Filters			Horizontal Roof Curb	
	156, 180	210, 240, 300		Low/Standard Heat	Medium Heat	High Heat		MERV 8	MERV 13	MERV 16	156 thru 240	300
2750	.01	.02	.01	.02	.04	.05	---	.01	.03	0.06	.03	-
3000	.01	.02	.01	.03	.04	.05	---	.01	.03	0.06	.04	-
3250	.01	.03	.01	.03	.05	.06	---	.01	.04	0.07	.04	.01
3500	.01	.03	.02	.03	.05	.06	---	.01	.04	0.08	.05	.01
3750	.01	.03	.02	.04	.06	.07	---	.01	.04	0.08	.05	.01
4000	.02	.04	.02	.04	.06	.07	---	.01	.04	0.09	.06	.02
4250	.02	.04	.02	.04	.06	.08	---	.01	.05	0.10	.07	.02
4500	.02	.05	.02	.05	.07	.09	---	.01	.05	0.10	.07	.02
4750	.02	.05	.02	.05	.08	.10	---	.02	.05	0.11	.08	.03
5000	.02	.05	.02	.05	.09	.11	---	.02	.06	0.12	.08	.03
5250	.02	.06	.03	.06	.10	.12	---	.02	.06	0.12	.09	.04
5500	.02	.07	.03	.06	.10	.13	---	.02	.06	0.13	.10	.04
5750	.03	.07	.03	.06	.11	.14	---	.02	.07	0.14	.11	.05
6000	.03	.08	.03	.07	.12	.15	---	.03	.07	0.14	.11	.06
6250	.03	.08	.03	.07	.12	.16	.01	.03	.07	0.15	.12	.07
6500	.03	.09	.04	.08	.13	.17	.02	.03	.08	0.16	.13	.08
6750	.04	.10	.04	.08	.14	.18	.03	.03	.08	0.17	.14	.08
7000	.04	.10	.04	.09	.15	.19	.04	.04	.08	0.17	.15	.09
7250	.04	.11	.04	.09	.16	.20	.05	.04	.09	0.18	.16	.10
7500	.05	.12	.05	.10	.17	.21	.06	.04	.09	0.19	.17	.11
8000	.05	.13	.05	.11	.19	.24	.09	.05	.10	0.21	.19	.13
8500	.06	.15	.05	.12	.20	.26	.11	.05	.10	0.22	.21	.15
9000	.07	.16	.06	.13	.23	.29	.14	.06	.11	0.24	.24	.17
9500	.08	.18	.07	.14	.25	.32	.16	.07	.12	0.25	.26	.19
10,000	.08	.20	.07	.16	.27	.35	.19	.07	.12	0.27	.29	.21
10,500	.09	.22	.08	.17	.30	.38	.22	.08	.13	0.29	.31	.24
11,000	.11	.24	.08	.18	.31	.40	.25	.09	.14	0.30	.34	.27

## BLOWER DATA

### POWER EXHAUST FAN PERFORMANCE

Return Air System Static Pressure	Air Volume Exhausted
in. w.g.	cfm
0.00	8630
0.05	8210
0.10	7725
0.15	7110
0.20	6470
0.25	5790
0.30	5060
0.35	4300
0.40	3510
0.45	2690
0.50	1840

### CEILING DIFFUSER AIR RESISTANCE - in. w.g.

Air Volume cfm	Step-Down Diffuser						Flush Diffuser	
	RTD11-185S			RTD11-275S			FD11-185S	FD11-275S
	2 Ends Open	1 Side/2 Ends Open	All Ends & Sides Open	2 Ends Open	1 Side/2 Ends Open	All Ends & Sides Open		
5000	0.51	0.44	0.39	---	---	---	0.27	---
5200	0.56	0.48	0.42	---	---	---	0.30	---
5400	0.61	0.52	0.45	---	---	---	0.33	---
5600	0.66	0.56	0.48	---	---	---	0.36	---
5800	0.71	0.59	0.51	---	---	---	0.39	---
6000	0.76	0.63	0.55	0.36	0.31	0.27	0.42	0.29
6200	0.80	0.68	0.59	---	---	---	0.46	---
6400	0.86	0.72	0.63	---	---	---	0.50	---
6500	---	---	---	0.42	0.36	0.31	---	0.34
6600	0.92	0.77	0.67	---	---	---	0.54	---
6800	0.99	0.83	0.72	---	---	---	0.58	---
7000	1.03	0.87	0.76	0.49	0.41	0.36	0.62	0.40
7200	1.09	0.92	0.80	---	---	---	0.66	---
7400	1.15	0.97	0.84	---	---	---	0.70	---
7500	---	---	---	0.51	0.46	0.41	---	0.45
7600	1.20	1.02	0.88	---	---	---	0.74	---
8000	---	---	---	0.59	0.49	0.43	---	0.50
8500	---	---	---	0.69	0.58	0.50	---	0.57
9000	---	---	---	0.79	0.67	0.58	---	0.66
9500	---	---	---	0.89	0.75	0.65	---	0.74
10,000	---	---	---	1.00	0.84	0.73	---	0.81
10,500	---	---	---	1.10	0.92	0.80	---	0.89
11,000	---	---	---	1.21	1.01	0.88	---	0.96

### CEILING DIFFUSER AIR THROW DATA - ft.

Size	Air Volume cfm	<sup>1</sup> Effective Throw Range - ft.		Size	Air Volume cfm	<sup>1</sup> Effective Throw Range - ft.	
		RTD11-185S Step-Down	FD11-185S Flush			RTD11-275S Step-Down	FD11-275S Flush
156 180	5600	39 - 49	28 - 37	210 240 300	7200	33 - 38	26 - 35
	5800	42 - 51	29 - 38		7400	35 - 40	28 - 37
	6000	44 - 54	40 - 50		7600	36 - 41	29 - 38
	6200	45 - 55	42 - 51		7800	38 - 43	40 - 50
	6400	46 - 55	43 - 52		8000	39 - 44	42 - 51
	6600	47 - 56	45 - 56		8200	41 - 46	43 - 52
					8400	43 - 49	44 - 54
					8600	44 - 50	46 - 57
					8800	47 - 55	48 - 59

<sup>1</sup> Throw is the horizontal or vertical distance an airstream travels on leaving the outlet or diffuser before the maximum velocity is reduced to 50 ft. per minute. Four sides open.

**ELECTRICAL DATA** **13 TON**

Model		LGM156U5					
<sup>1</sup> Voltage - 60Hz		208/230V-3ph		460V-3ph		575V-3ph	
Compressor 1 (Inverter)	Rated Load Amps	10.2		6.2		5.6	
	Locked Rotor Amps	21		12		12	
Compressor 2 (Non-Inverter)	Rated Load Amps	13.5		6.4		5.1	
	Locked Rotor Amps	120.4		50		41	
Compressor 3 (Non-Inverter)	Rated Load Amps	13.5		6.4		5.1	
	Locked Rotor Amps	120.4		50		41	
Outdoor Fan Motors (4)	Full Load Amps (4 ECM)	2.8		1.4		1.1	
	Total	11.2		5.6		4.4	
Power Exhaust (2) 0.33 HP	Full Load Amps	2.4		1.3		1	
	Total	4.8		2.6		2	
Service Outlet 115V GFI (amps)		15		15		20	
Indoor Blower Motor	Horsepower	3	5	3	5	3	5
	Full Load Amps	10.6	16.7	4.8	7.6	3.9	6.1
<sup>2</sup> Maximum Overcurrent Protection (MOCP)	Unit Only	70	80	35	40	30	30
	With (2) 0.33 HP Power Exhaust	80	90	40	40	30	35
<sup>3</sup> Minimum Circuit Ampacity (MCA)	Unit Only	63	70	31	35	26	28
	With (2) 0.33 HP Power Exhaust	68	75	34	37	28	30

**ELECTRICAL DATA** **15 TON**

Model		LGM180U5								
<sup>1</sup> Voltage - 60Hz		208/230V-3ph			460V-3ph			575V-3ph		
Compressor 1 (Inverter)	Rated Load Amps	14.1			7.8			7		
	Locked Rotor Amps	21			12			12		
Compressor 2 (Non-Inverter)	Rated Load Amps	13.5			6.4			5.1		
	Locked Rotor Amps	120.4			50			41		
Compressor 3 (Non-Inverter)	Rated Load Amps	16			7.1			6.4		
	Locked Rotor Amps	156.4			69			47.8		
Outdoor Fan Motors	Full Load Amps (4 ECM)	2.8			1.4			1.1		
	Total	11.2			5.6			4.4		
Power Exhaust (2) 0.33 HP	Full Load Amps	2.4			1.3			1		
	Total	4.8			2.6			2		
Service Outlet 115V GFI (amps)		15			15			20		
Indoor Blower Motor	Horsepower	3	5	7.5	3	5	7.5	3	5	7.5
	Full Load Amps	10.6	16.7	24.2	4.8	7.6	11	3.9	6.1	9
<sup>2</sup> Maximum Overcurrent Protection (MOCP)	Unit Only	80	90	100	40	40	50	35	35	40
	With (2) 0.33 HP Power Exhaust	90	90	110	40	45	50	35	35	45
<sup>3</sup> Minimum Circuit Ampacity (MCA)	Unit Only	70	76	86	34	37	41	29	31	35
	With (2) 0.33 HP Power Exhaust	75	81	90	37	40	44	31	33	37

NOTE - All units have a minimum Short Circuit Current Rating (SCCR) of 5000 amps.

<sup>1</sup> Extremes of operating range are plus and minus 10% of line voltage.

<sup>2</sup> HACR type breaker or fuse.

<sup>3</sup> Refer to National or Canadian Electrical Code manual to determine wire, fuse and disconnect size requirements.

**ELECTRICAL DATA**
**17.5 TON**

Model		LGM210U5								
<sup>1</sup> Voltage - 60Hz		208/230V-3ph			460V-3ph			575V-3ph		
Compressor 1 (Inverter)	Rated Load Amps	10.3			6.2			5.6		
	Locked Rotor Amps	21			12			12		
Compressor 2 (Non-Inverter)	Rated Load Amps	13.5			6.4			5.1		
	Locked Rotor Amps	120.4			50			41		
Compressor 3 (Non-Inverter)	Rated Load Amps	13.5			6.4			5.1		
	Locked Rotor Amps	120.4			50			41		
Compressor 4 (Non-Inverter)	Rated Load Amps	13.5			6.4			5.1		
	Locked Rotor Amps	120.4			50			41		
Outdoor Fan Motors (6)	Full Load Amps (6 ECM)	2.8			1.4			1.1		
	Total	16.8			8.4			6.6		
Power Exhaust (2) 0.33 HP	Full Load Amps	2.4			1.3			1		
	Total	4.8			2.6			2		
Service Outlet 115V GFI (amps)		15			15			20		
Indoor Blower Motor	Horsepower	3	5	7.5	3	5	7.5	3	5	7.5
	Full Load Amps	10.6	16.7	24.2	4.8	7.6	11	3.9	6.1	9
<sup>2</sup> Maximum Overcurrent Protection (MOCP)	Unit Only	90	100	110	45	50	50	35	40	45
	With (2) 0.33 HP Power Exhaust	90	100	125	45	50	60	40	40	45
<sup>3</sup> Minimum Circuit Ampacity (MCA)	Unit Only	82	89	98	41	44	48	33	36	39
	With (2) 0.33 HP Power Exhaust	87	94	103	43	46	51	35	38	41

**ELECTRICAL DATA**
**20 TON**

Model		LGM240U5								
<sup>1</sup> Voltage - 60Hz		208/230V-3ph			460V-3ph			575V-3ph		
Compressor 1 (Inverter)	Rated Load Amps	13.3			7.4			6.9		
	Locked Rotor Amps	21			12			12		
Compressor 2 (Non-Inverter)	Rated Load Amps	13.1			6.6			4.8		
	Locked Rotor Amps	93			60			41		
Compressor 3 (Non-Inverter)	Rated Load Amps	13.1			6.6			4.8		
	Locked Rotor Amps	93			60			41		
Compressor 4 (Non-Inverter)	Rated Load Amps	13.1			6.6			4.8		
	Locked Rotor Amps	93			60			41		
Outdoor Fan Motors (6)	Full Load Amps (6 ECM)	2.8			1.4			1.1		
	Total	16.8			8.4			6.6		
Power Exhaust (2) 0.33 HP	Full Load Amps	2.4			1.3			1		
	Total	4.8			2.6			2		
Service Outlet 115V GFI (amps)		15			15			20		
Indoor Blower Motor	Horsepower	5	7.5	10	5	7.5	10	5	7.5	10
	Full Load Amps	16.7	24.2	30.8	7.6	11	14	6.1	9	11
<sup>2</sup> Maximum Overcurrent Protection (MOCP)	Unit Only	100	110	125	50	60	60	40	45	50
	With (2) 0.33 HP Power Exhaust	110	125	125	50	60	60	40	50	50
<sup>3</sup> Minimum Circuit Ampacity (MCA)	Unit Only	91	100	108	46	50	54	36	40	42
	With (2) 0.33 HP Power Exhaust	96	105	113	48	52	56	38	42	44

NOTE - All units have a minimum Short Circuit Current Rating (SCCR) of 5000 amps.

<sup>1</sup> Extremes of operating range are plus and minus 10% of line voltage.

<sup>2</sup> HACR type breaker or fuse.

<sup>3</sup> Refer to National or Canadian Electrical Code manual to determine wire, fuse and disconnect size requirements.

**ELECTRICAL DATA**

**25 TON**

Model		LGM300U5								
		208/230V-3ph			460V-3ph			575V-3ph		
<sup>1</sup> Voltage - 60Hz										
Compressor 1 (Inverter)	Rated Load Amps	12.9			7.3			6.7		
	Locked Rotor Amps	21			12			12		
Compressor 2 (Non-Inverter)	Rated Load Amps	21.2			9.1			7.7		
	Locked Rotor Amps	156.5			74.8			47.8		
Compressor 3 (Non-Inverter)	Rated Load Amps	22.4			9.1			7.2		
	Locked Rotor Amps	166.2			74.6			54		
Compressor 4 (Non-Inverter)	Rated Load Amps	22.4			9.1			7.2		
	Locked Rotor Amps	166.2			74.6			54		
Outdoor Fan Motors (6)	Full Load Amps (6 ECM)	2.8			1.4			1.1		
	Total	16.8			8.4			6.6		
Power Exhaust (2) 0.33 HP	Full Load Amps	2.4			1.3			1		
	Total	4.8			2.6			2		
Service Outlet 115V GFI (amps)		15			15			20		
Indoor Blower Motor	Horsepower	5	7.5	10	5	7.5	10	5	7.5	10
	Full Load Amps	16.7	24.2	30.8	7.6	11	14	6.1	9	11
<sup>2</sup> Maximum Overcurrent Protection (MOCP)	Unit Only	125	150	150	60	60	70	50	50	60
	With (2) 0.33 HP Power Exhaust	125	150	150	60	70	70	50	50	60
<sup>3</sup> Minimum Circuit Ampacity (MCA)	Unit Only	118	126	135	53	57	61	44	47	50
	With (2) 0.33 HP Power Exhaust	123	131	139	56	60	64	46	49	52

NOTE - All units have a minimum Short Circuit Current Rating (SCCR) of 5000 amps.

<sup>1</sup> Extremes of operating range are plus and minus 10% of line voltage.

<sup>2</sup> HACR type breaker or fuse.

<sup>3</sup> Refer to National or Canadian Electrical Code manual to determine wire, fuse and disconnect size requirements.

## ELECTRICAL ACCESSORIES

### DISCONNECTS

Voltage	208V	240V	208V	240V	208V	240V	460V	460V	460V	575V	575V	575V
Model No.	LGM156U5											
Blower Motor HP	3		5		---		3	5	---	3	5	---
Unit Only	54W88	54W88	54W88	54W88	---	---	54W88	54W88	---	54W88	54W88	---
Unit w/ Power Exhaust	54W88	54W88	54W89	54W89	---	---	54W88	54W88	---	54W88	54W88	---
Model No.	LGM180U5											
Blower Motor HP	3		5		7.5		3	5	7.5	3	5	7.5
Unit Only	54W88	54W88	54W89	54W89	54W89	54W89	54W88	54W88	54W88	54W88	54W88	54W88
Unit w/ Power Exhaust	54W89	54W89	54W89	54W89	54W89	54W89	54W88	54W88	54W88	54W88	54W88	54W88
Model No.	LGM210U5											
Blower Motor HP	3		5		7.5		3	5	7.5	3	5	7.5
Unit Only	54W89	54W89	54W89	54W89	54W89	54W89	54W88	54W88	54W88	54W88	54W88	54W88
Unit w/ Power Exhaust	54W89	54W89	54W89	54W89	54W89	54W89	54W88	54W88	54W88	54W88	54W88	54W88
Model No.	LGM240U5											
Blower Motor HP	5		7.5		10		5	7.5	10	5	7.5	10
Unit Only	54W89	54W89	54W89	54W89	54W89	54W89	54W88	54W88	54W88	54W88	54W88	54W88
Unit w/ Power Exhaust	54W89	54W89	54W89	54W89	54W89	54W89	54W88	54W88	54W88	54W88	54W88	54W88
Model No.	LGM300U5											
Blower Motor HP	5		7.5		10		5	7.5	10	5	7.5	10
Unit Only	54W89	54W89	54W89	54W89	54W89	54W89	54W88	54W88	54W88	54W88	54W88	54W88
Unit w/ Power Exhaust	54W89	54W89	54W89	54W89	90W82	90W82	54W88	54W88	54W88	54W88	54W88	54W88

Disconnects - 54W88 - 80A  
 54W89 - 150A  
 90W82 - 250A

#### FIELD WIRING NOTES

- For use with copper wiring only
- Field wiring not furnished
- All wiring must conform to NEC or CEC and local electrical codes
- For specific wiring information, please refer to the installation instructions

# INSTALLATION CLEARANCES

## Unit With Economizer

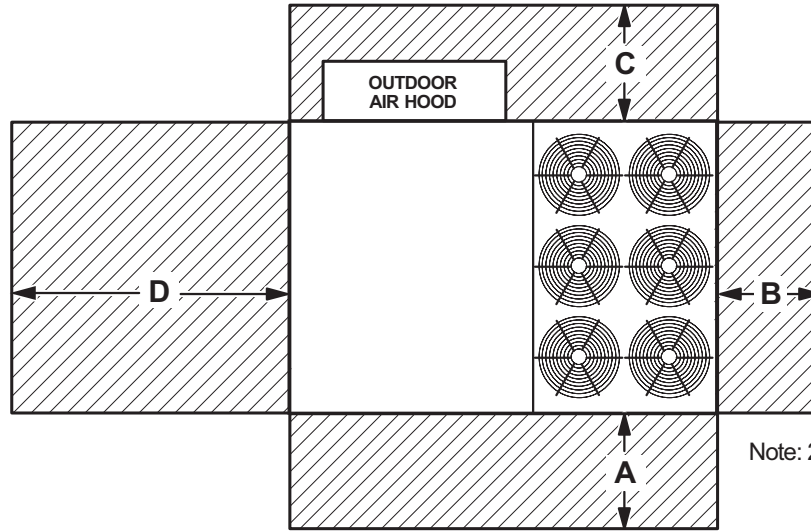

Note: 210-240-300 sizes shown

<sup>1</sup> Unit Clearance	A		B		C		D		Top Clearance
	in.	mm	in.	mm	in.	mm	in.	mm	
<b>Service Clearance</b>	60	1524	36	914	36	934	66	1676	Unobstructed
<b>Clearance to Combustibles</b>	36	914	1	25	1	25	1	25	
<b>Minimum Operation Clearance</b>	45	1143	36	914	36	914	41	1041	

NOTE - Entire perimeter of unit base requires support when elevated above the mounting surface.

<sup>1</sup> Service Clearance - Required for removal of serviceable parts.

Clearance to Combustibles - Required clearance to combustible material.

Minimum Operation Clearance - Required clearance for proper unit operation.

## OUTDOOR SOUND DATA

Size	Octave Band Sound Power Levels dBA, re 10 <sup>-12</sup> Watts - Center Frequency - Hz							<sup>1</sup> Sound Rating Number (dBA)
	125	250	500	1000	2000	4000	8000	
156, 180	71	76	80	78	74	70	63	86
210, 240, 300	73	81	86	84	78	73	67	90

Note - The octave sound power data does not include tonal corrections.

<sup>1</sup> Sound Rating Number according to AHRI Standard 370-2001 (includes pure tone penalty).

Sound Rating Number is the overall A-Weighted Sound Power Level (L<sub>WA</sub>), dBA (100 Hz to 10,000 Hz).

WEIGHT DATA				UNIT
Size	Net		Shipping	
	lbs.	kg	lbs.	kg
156 Base Unit	2201	998	2401	1089
156 Max. Unit	2485.8	1128	2686	1218
180 Base Unit	2204	1000	2404	1090
180 Max. Unit	2489	1129	2689	1220
210 Base Unit	2643	1199	2843	1290
210 Max. Unit	2928	1328	3128	1419
240 Base Unit	2670	1211	2870	1301
240 Max. Unit	2955	1340	3155	1431
300 Base Unit	2711	1229	2911	1320
300 Max. Unit	2996	1359	3196	1449

Max. Unit - The unit with ALL INTERNAL OPTIONS Installed. (Economizer, Standard Static Power Exhaust Fans, Controls, etc.). Does not include accessories external to unit.

FACTORY / FIELD INSTALLED OPTIONS AND ACCESSORIES - NET WEIGHTS			
Description		lbs.	kg
<b>ECONOMIZER / OUTDOOR AIR / EXHAUST</b>			
<b>Economizer</b>			
Economizer Dampers (with Outdoor Air Hood)		167	76
Barometric Relief Dampers (downflow)		30	14
Barometric Relief Dampers (horizontal)		20	9
<b>Outdoor Air Dampers</b>			
Outdoor Air Damper Section (downflow) - Automatic (including Hood)		39	18
Outdoor Air Damper Section (downflow) - Manual (including Hood)		22	10
<b>Power Exhaust</b>		62	28
<b>GAS HEAT EXCHANGER (NET WEIGHT)</b>			
Medium Heat (adder over standard heat)		18	8
High Heat (adder over standard heat)		64	29
<b>COMBINATION COIL/HAIL GUARDS</b>			
All models		36	16
<b>ROOF CURBS</b>			
<b>Hybrid Roof Curbs, Downflow</b>			
8 in. height		136	62
14 in. height		169	77
18 in. height		191	87
24 in. height		224	102
<b>Adjustable Pitch Curb, Downflow</b>			
14 in. height		224	102
<b>Horizontal, Standard</b>			
26 in. height		450	204
37 in. height		540	245
30 in. height		495	225
41 in. height		575	261
<b>CEILING DIFFUSERS</b>			
<b>Step-Down</b>	RTD11-185S	168	76
	RTD11-275S	238	108
<b>Flush</b>	FD11-185S	168	76
	FD11-275S	238	108
<b>Transitions</b>	C1DIFF33C-1	80	36
	C1DIFF34C-1	75	34
<b>HUMIDITROL™+ HOT GAS REHEAT SYSTEM</b>			
Humiditrol+ Dehumidification Option		50	23

**DIMENSIONS**

**LGM156 | LGM180**

**CORNER WEIGHTS**

**CENTER OF GRAVITY**

Model	AA		BB		CC		DD		EE		FF	
	lbs.	kg	lbs.	kg	lbs.	kg	lbs.	kg	in.	mm	in.	mm
LGM156 Base Unit	490	223	435	198	600	273	676	307	50-5/8	1288	38-1/4	972
LGM156 Max. Unit	603	274	517	235	630	287	735	334	49-3/4	1264	41	1043
LGM180 Base Unit	490	223	435	198	601	273	677	308	50-5/8	1287	38-1/4	971
LGM180 Max. Unit	603	274	517	235	632	287	737	335	49-3/4	1263	41	1042

Base Unit - The unit with NO INTERNAL OPTIONS.

Max. Unit - The unit with ALL INTERNAL OPTIONS Installed. (Economizer, Standard Static Power Exhaust Fans, Controls, etc.). Does not include accessories external to unit.

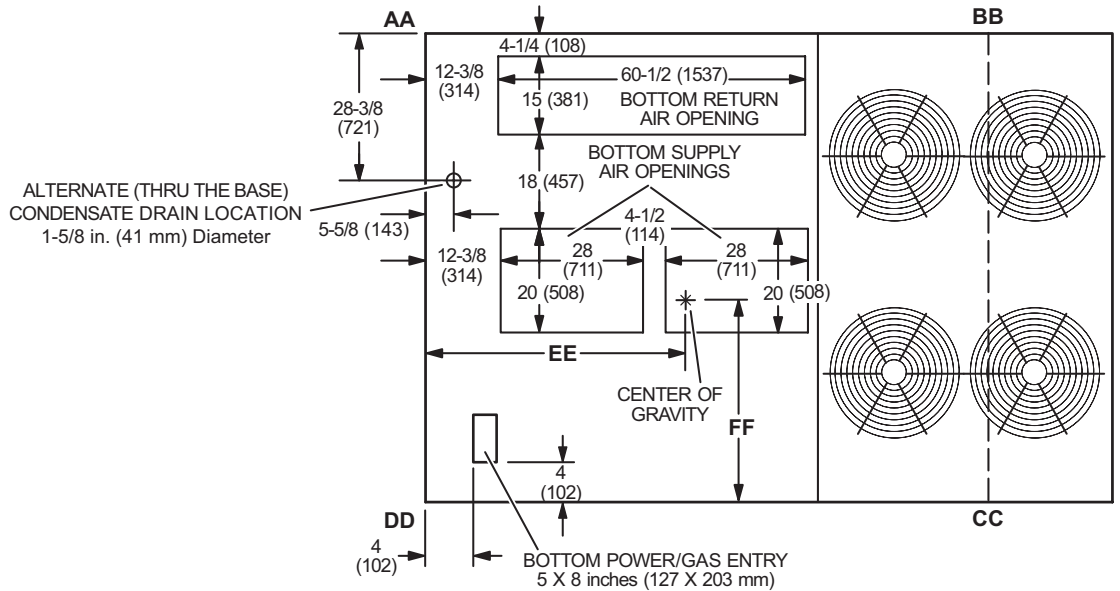

**TOP VIEW**

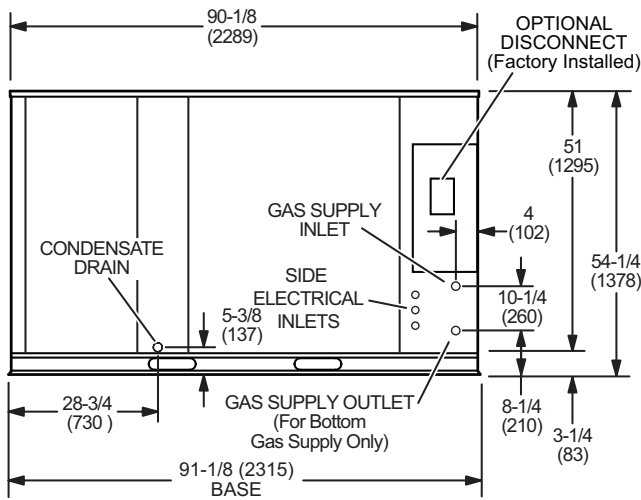

**END VIEW**

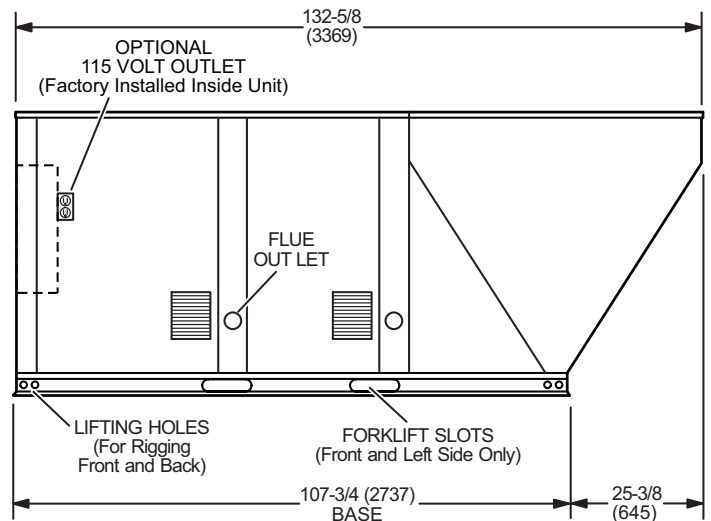

**SIDE VIEW**

**DIMENSIONS - UNIT**

**LGM210 | LGM240 | LGM300**

**CORNER WEIGHTS**

**CENTER OF GRAVITY**

Model	AA		BB		CC		DD		EE		FF	
	lbs.	kg	lbs.	kg	lbs.	kg	lbs.	kg	in.	mm	in.	mm
LGM210 Base Unit	520	237	619	281	817	371	687	312	58-1/2	1487	39-1/4	997
LGM210 Max. Unit	631	287	708	322	840	382	749	340	57	1448	41-5/8	1059
LGM240 Base Unit	526	239	609	277	824	374	711	323	57-7/8	1469	38-3/4	984
LGM240 Max. Unit	636	289	702	319	848	386	768	349	56-1/2	1436	41-1/4	1048
LGM300 Base Unit	532	242	599	272	837	380	743	338	57	1449	38	965
LGM300 Max. Unit	641	291	687	312	862	392	805	366	55-3/4	1416	40-1/2	1026

Base Unit - The unit with NO INTERNAL OPTIONS.

Max. Unit - The unit with ALL INTERNAL OPTIONS Installed. (Economizer, Standard Static Power Exhaust Fans, Controls, etc.). Does not include accessories external to unit.

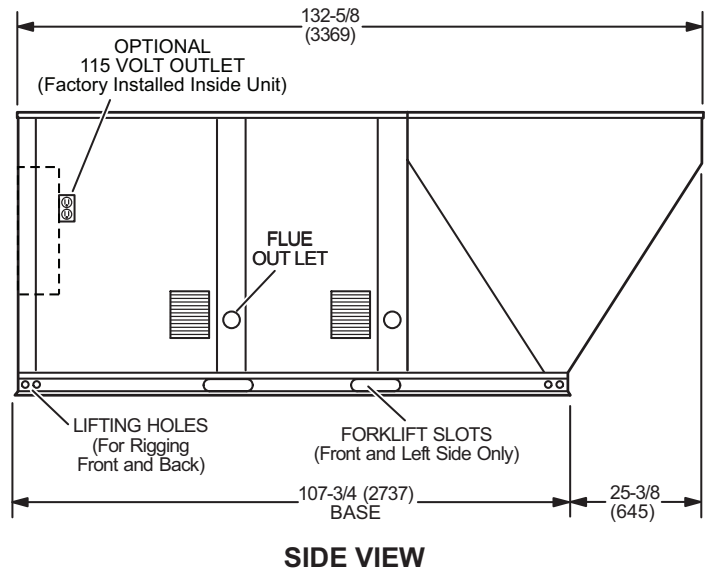
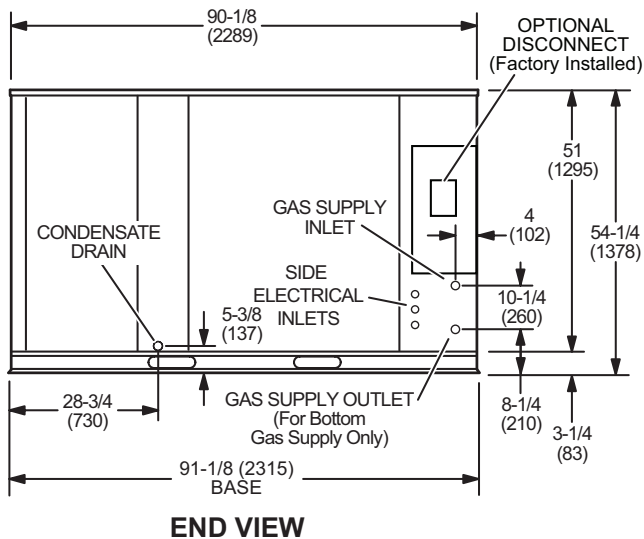
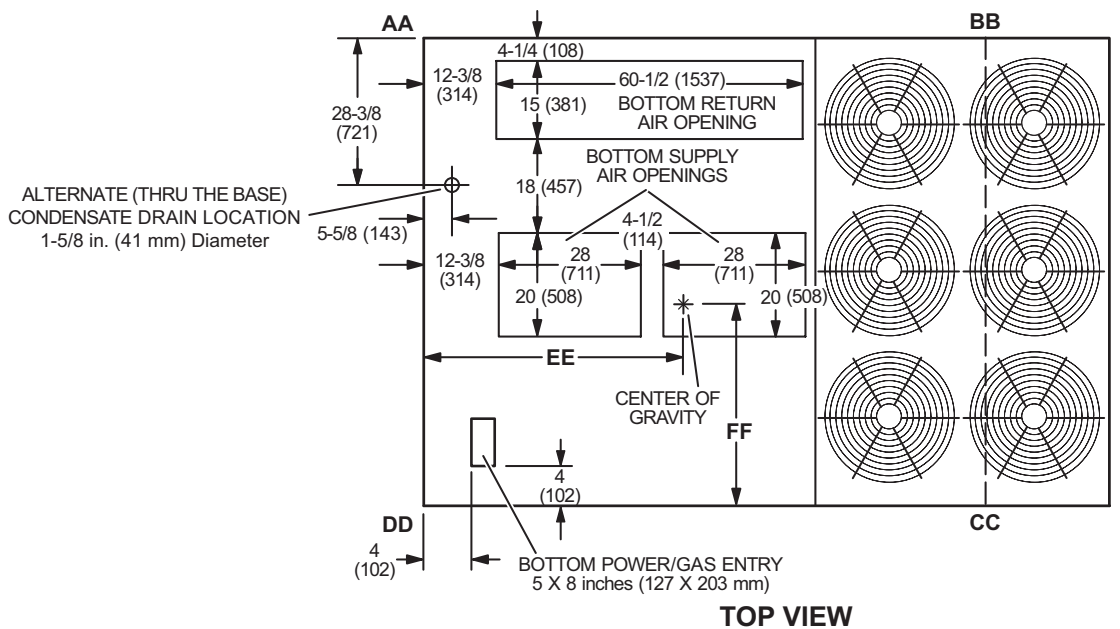

**OUTDOOR AIR HOOD DETAIL**

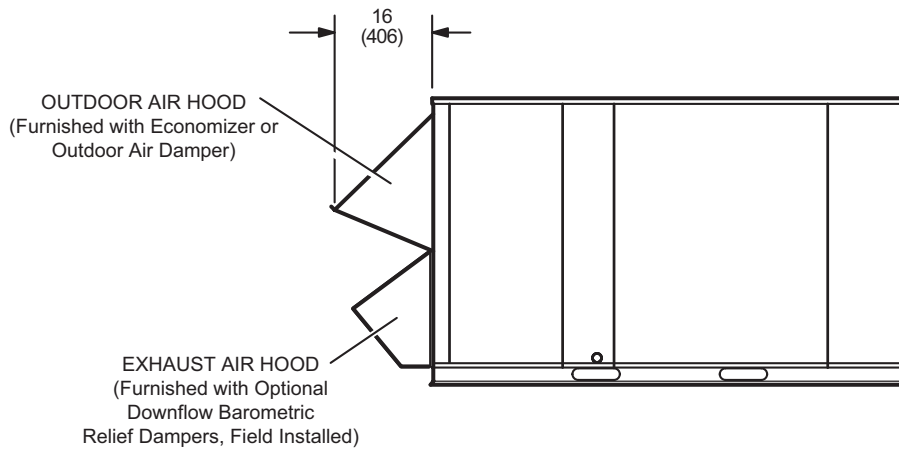

**OPTIONAL HORIZONTAL BAROMETRIC RELIEF DAMPERS WITH HOOD**

(Field installed in horizontal return air duct adjacent to unit)

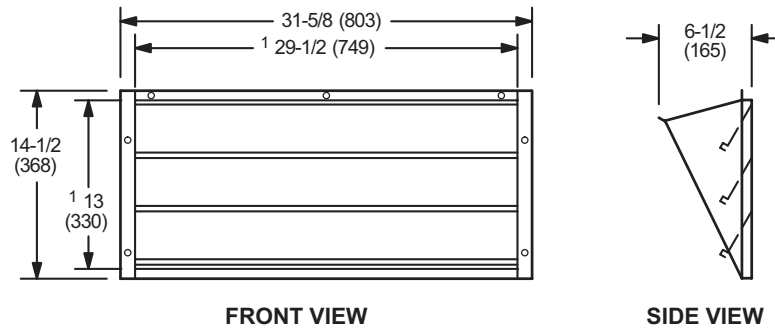

NOTE - Two furnished per order no.  
<sup>1</sup> NOTE - Opening size required in return air duct.

**HYBRID ROOF CURBS - DOUBLE DUCT OPENING**

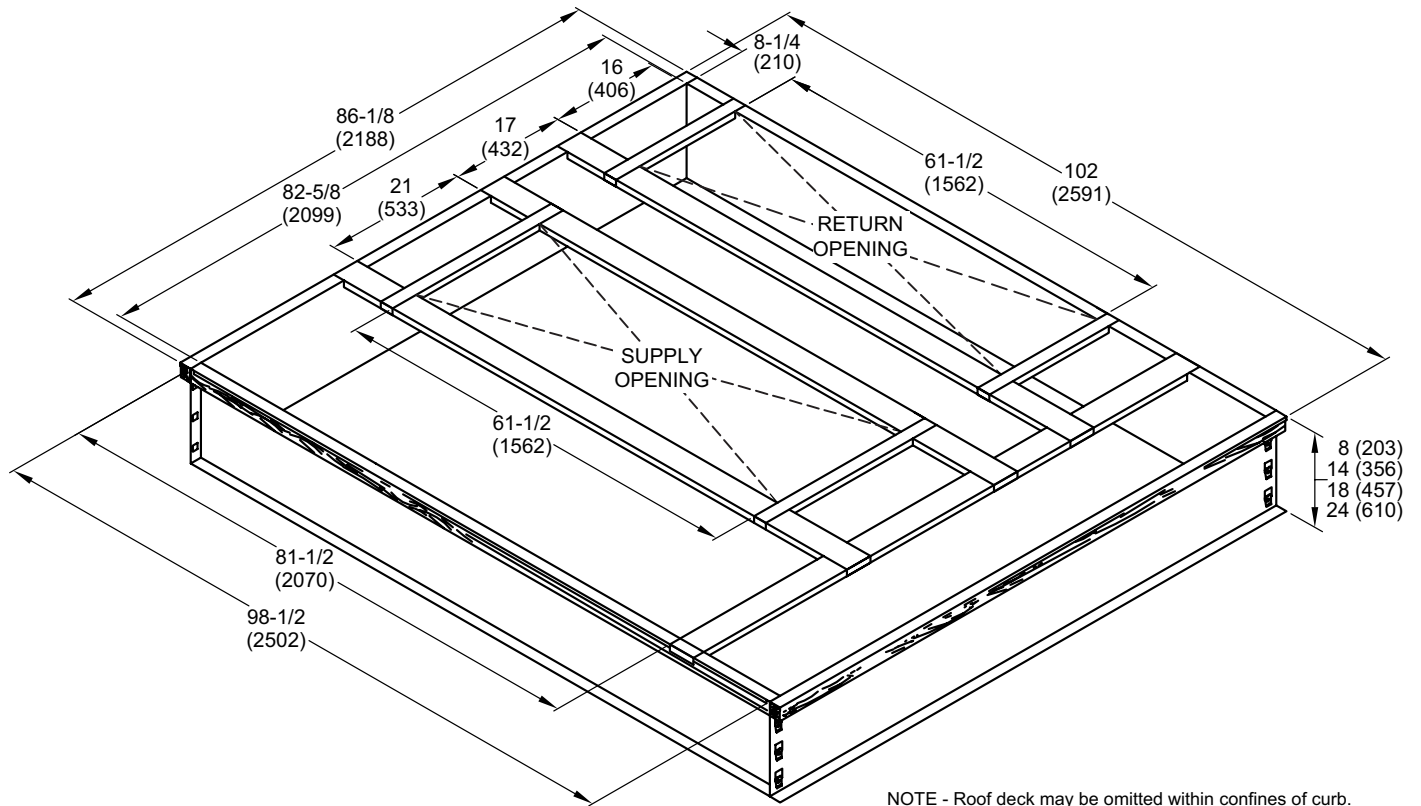

**TYPICAL FLASHING DETAIL FOR ROOF CURB**

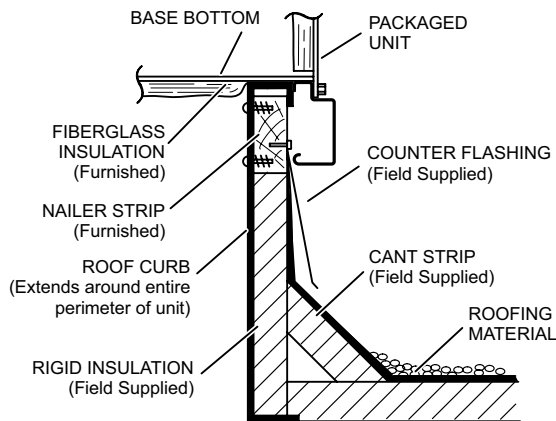

**DETAIL ROOF CURB**

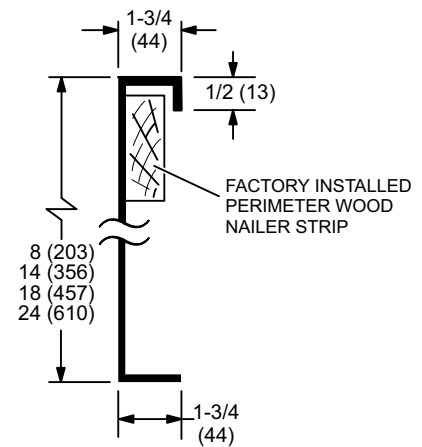

**ADJUSTABLE PITCH CURB - DOUBLE DUCT OPENING**

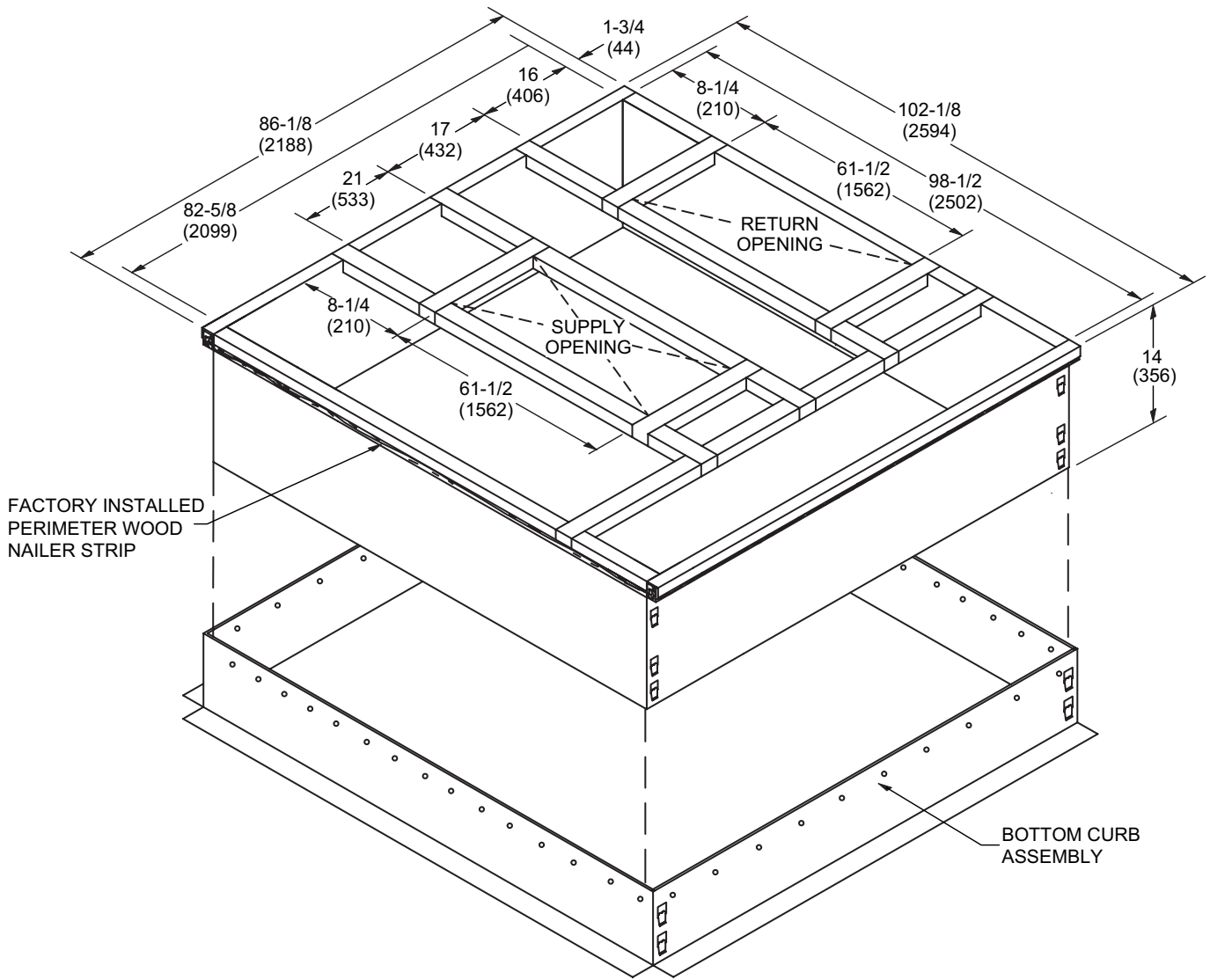

NOTE - Maximum slope pitch is 3/4 in. per 1 foot (19 mm per 305 mm) in any one direction.

**TYPICAL FLASHING DETAIL FOR ROOF CURB**

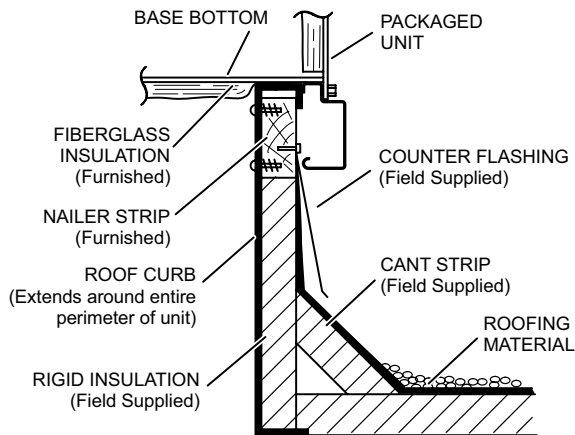

**DETAIL ROOF CURB**

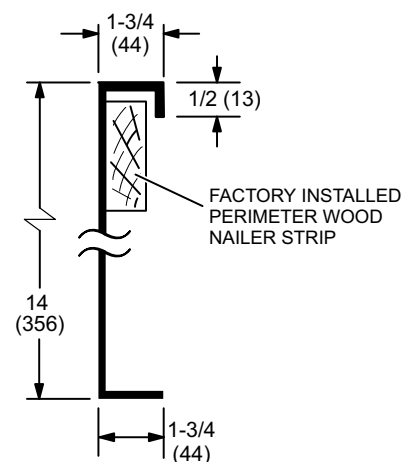

**ROOF CURBS WITH SUPPLY & RETURN AIR TRANSITIONS FOR CEILING DIFFUSERS**

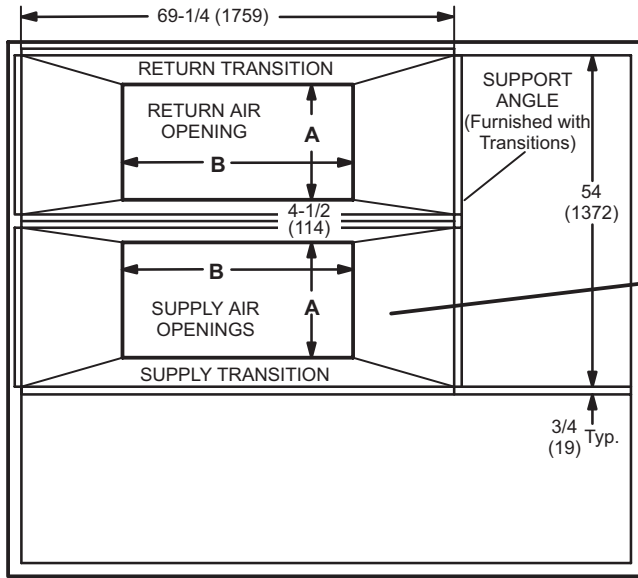

**TOP VIEW**

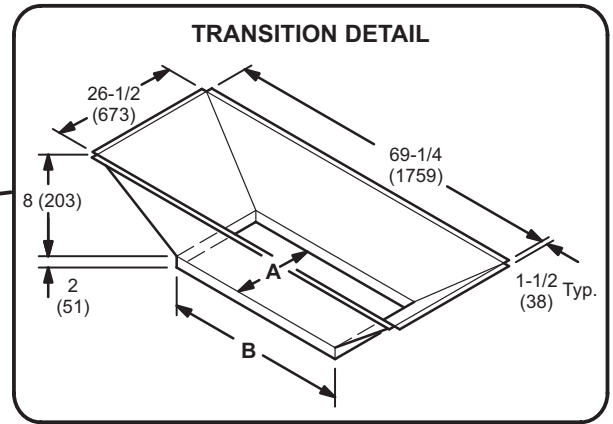

**TRANSITION OPENING SIZES**

Model Number	A		B	
	inch	mm	inch	mm
C1DIFF33C-1	18	457	36	914
C1DIFF34C-1	24	610	48	1219

**HORIZONTAL ROOF CURBS – Requires Optional Horizontal Return Air Panel Kit**

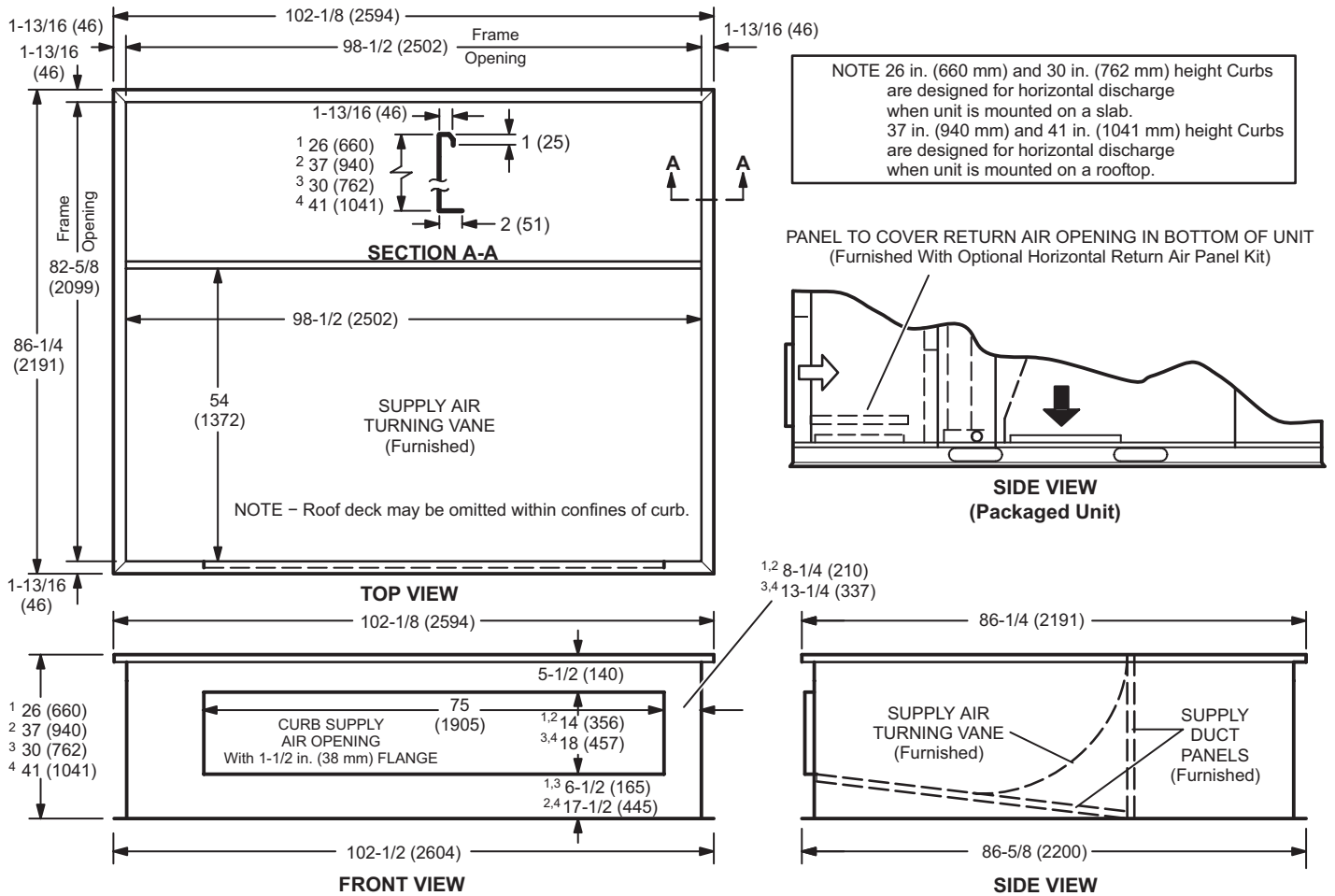

<sup>1</sup> Slab Applications    <sup>2</sup> Rooftop Applications    <sup>3</sup> Slab Applications (used with 300 only)    <sup>4</sup> Rooftop Applications (used with 300 only)

**HORIZONTAL SUPPLY AND RETURN AIR OPENINGS WITH HORIZONTAL ROOF CURB**

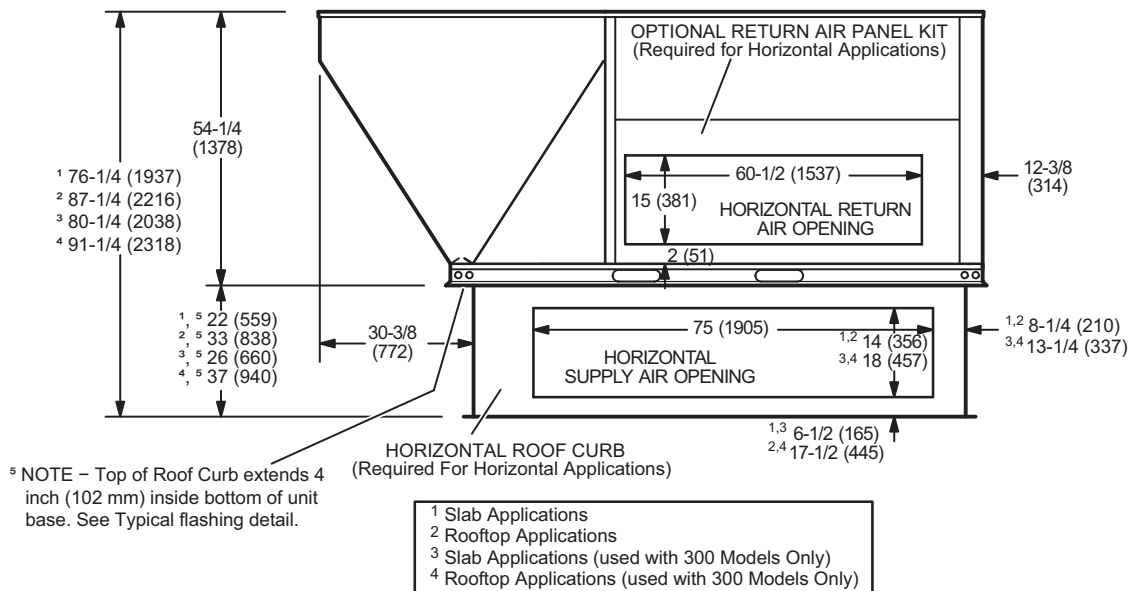

**COMBINATION CEILING SUPPLY AND RETURN DIFFUSERS**

**STEP-DOWN CEILING DIFFUSER**

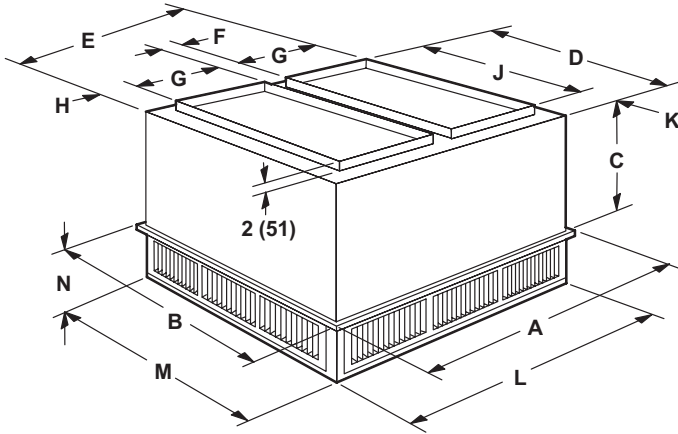

**FLUSH CEILING DIFFUSER**

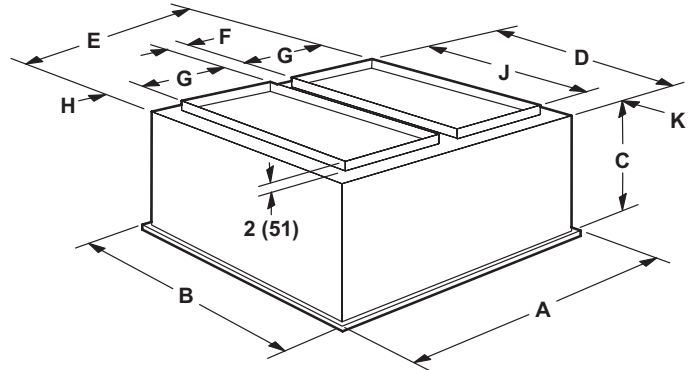

Model		RTD11-185S	RTD11-275S
<b>A</b>	in.	47-5/8	59-5/8
	mm	1210	1514
<b>B</b>	in.	47-5/8	59-5/8
	mm	1210	1514
<b>C</b>	in.	24-5/8	30-5/8
	mm	625	778
<b>D</b>	in.	45-1/2	57-1/2
	mm	1156	1461
<b>E</b>	in.	45-1/2	57-1/2
	mm	1156	1461
<b>F</b>	in.	4-1/2	4-1/2
	mm	114	114
<b>G</b>	in.	18	24
	mm	457	610
<b>H</b>	in.	2-1/2	2-1/2
	mm	64	64
<b>J</b>	in.	36	48
	mm	914	1219
<b>K</b>	in.	4-3/4	4-3/4
	mm	121	121
<b>L</b>	in.	45-1/2	57-1/2
	mm	1156	1461
<b>M</b>	in.	45-1/2	57-1/2
	mm	1156	1461
<b>N</b>	in.	10-1/8	11-1/8
	mm	257	283
<b>Duct Size</b>	in.	18 x 36	24 x 48
	mm	457 x 914	610 x 1219

Model		FD11-185S	FD11-275S
<b>A</b>	in.	47-5/8	59-5/8
	mm	1210	1514
<b>B</b>	in.	47-5/8	59-5/8
	mm	1210	1514
<b>C</b>	in.	29-1/4	35-1/4
	mm	743	895
<b>D</b>	in.	45	57
	mm	1143	1148
<b>E</b>	in.	45	57
	mm	1143	1448
<b>F</b>	in.	4-1/2	4-1/2
	mm	114	114
<b>G</b>	in.	18	24
	mm	457	610
<b>H</b>	in.	2-1/4	2-1/4
	mm	57	57
<b>J</b>	in.	36	48
	mm	914	1219
<b>K</b>	in.	4-1/2	4-1/2
	mm	114	114
<b>Duct Size</b>	in.	18 x 36	24 x 48
	mm	457 x 914	610 x 1219



## REVISIONS

Sections	Description of Change
Options / Accessories	Added modulating gas option.



Visit us at [www.Lennox.com](http://www.Lennox.com)

For the latest technical information, [www.LennoxCommercial.com](http://www.LennoxCommercial.com)

Contact us at 1-800-4-LENNOX

NOTE - Due to Lennox' ongoing commitment to quality, Specifications, Ratings and Dimensions subject to change without notice and without incurring liability. Improper installation, adjustment, alteration, service or maintenance can cause property damage or personal injury. Installation and service must be performed by a qualified installer and servicing agency.

©2026 Lennox Industries, Inc.