



© 2026 Lennox Industries Inc.
Dallas, Texas USA



INSTALLATION INSTRUCTIONS SLP99UHVK

DAVE LENNOX SIGNATURE®
COLLECTION GAS FURNACES
UP/FLOW HORIZONTAL AIR DISCHARGE

508587-03
05/2026

**THIS MANUAL MUST BE LEFT WITH THE
HOMEOWNER FOR FUTURE REFERENCE**

! This is a safety alert symbol and should never be ignored. When you see this symbol on labels or in manuals, be alert to the potential for personal injury or death.

! CAUTION

As with any mechanical equipment, contact with sharp sheet metal edges can result in personal injury. Take care while handling this equipment and wear gloves and protective clothing.

! NOTICE

A thermostat is not included and must be ordered separately.

- A communicating thermostat must be used in communicating applications.
- In non-communicating applications, the Lennox CS7500 thermostat may be used, as well as other non-communicating thermostats.

In all cases, setup is critical to ensure proper system operation.

Field wiring for both communicating and non-communicating applications is illustrated in diagrams, which begin on Page 35

! WARNING

This furnace is equipped with an ignition control factory enabled for use with Lennox A2L refrigerant systems. Disabling the refrigerant detection functionality on A2L system is prohibited by safety codes. Refer to furnace installation instructions for non-A2L and non-Lennox refrigerant system setup.

! WARNING

Improper installation, adjustment, alteration, service or maintenance can cause property damage, personal injury or loss of life. Installation and service must be performed by a licensed professional HVAC installer or equivalent, service agency, or the gas supplier.

Contents

Unit Dimensions	2
Parts Arrangement.....	3
SLP99UHVK Gas Furnace	4
Shipping and Packing List	4
Safety Information	4
Use of Furnace as Construction Heater	5
General.....	6
Installation - Setting Equipment.....	6
Filters.....	10
Duct System	10
Pipe Fittings Specifications.....	13
Joint Cementing Procedure.....	14
Venting Practices.....	15
Vent Pipe Guidelines	15
Gas Piping.....	30

Electrical.....	33
Ignition Control	44
Low GWP Application	53
Blower Data	56
Unit Start-Up.....	59
Gas Flow	62
Operating Pressure Signal Measurement	64
Proper Combustion.....	64
High Altitude Information	64
Other Unit Adjustments.....	64
Heating Sequence of Operation	65
Service.....	67
Repair Parts List.....	69
Configuring Unit Size Codes	70
Troubleshooting: Heating Sequence of Operation	71



Parts Arrangement

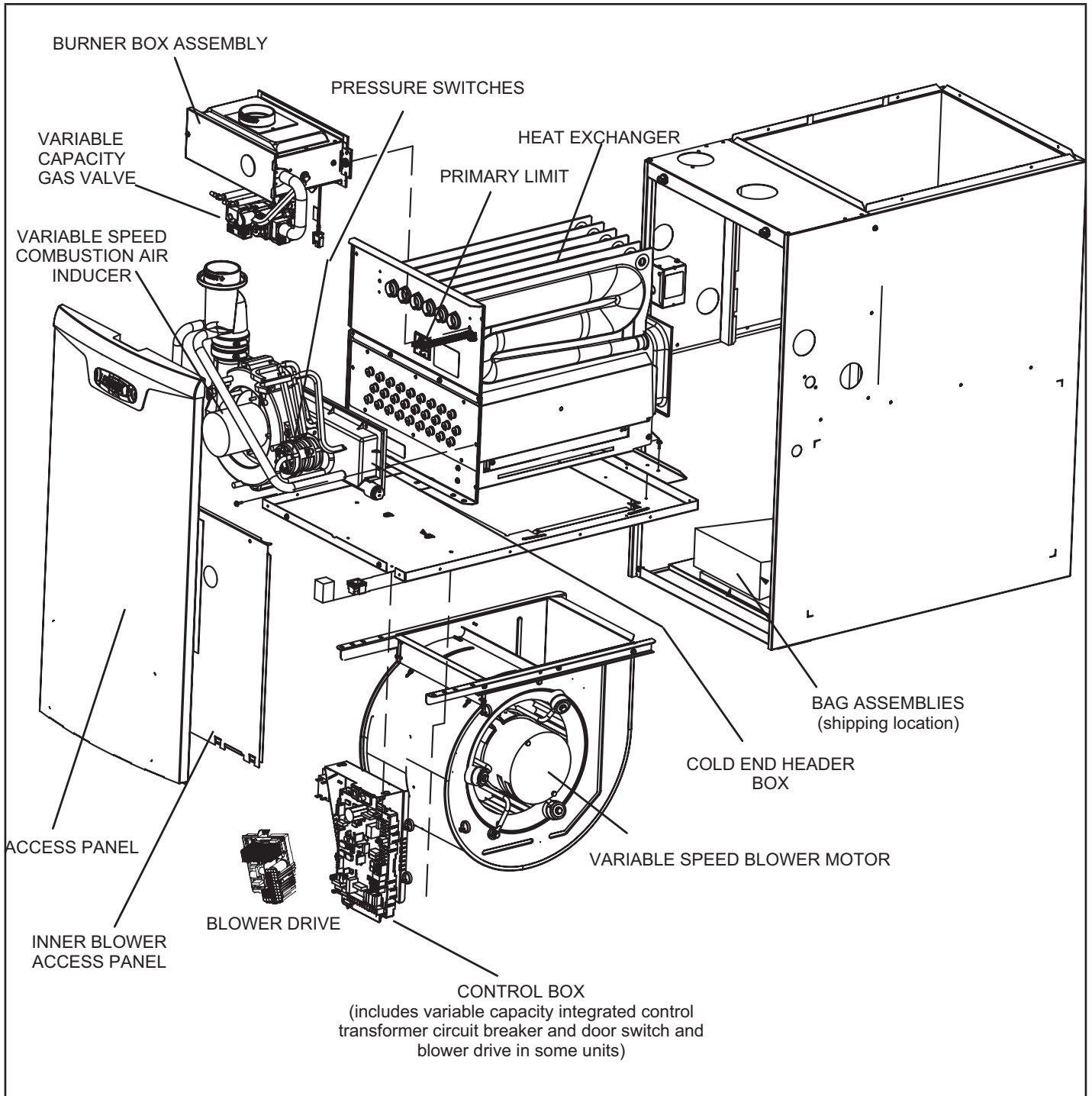

FIGURE 1

SLP99UHVK Gas Furnace

The SLP99UHVK category IV gas furnace is equipped with a variable-capacity, variable-speed integrated control. This control ensures compatibility with a communicating thermostat, the iHarmony® zone control system, or a thermostat which provides humidity control. Each SLP99UHVK is shipped ready for installation in the up-flow, horizontal left air discharge or horizontal right air discharge position. The furnace is equipped for natural gas applications only. A changeover kit may be ordered for LP applications.

The SLP99UHVK must be installed only as a Direct Vent gas furnace.

NOTE - In Direct Vent installations, combustion air is taken from outdoors and flue gases are discharged outdoors. See FIGURE 2 for applications including roof termination.

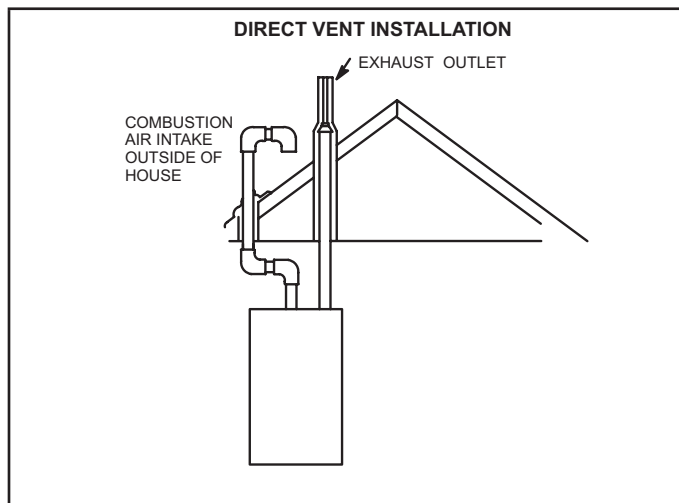

FIGURE 2

Shipping and Packing List

Package 1 of 1 contains

- 1 - Assembled SLP99UHVK unit
- 1 - Bag assembly containing the following:
 - 1 - Snap bushing
 - 1 - Snap plug
 - 1 - Wire tie
 - 1 - Condensate trap
 - 1 - Condensate trap cap
 - 1 - Condensate trap cap clamp
 - 1 - 3/4" Threaded street elbow
 - 1 -Flue Coupling
- 1- Bag containing discharge air sensor

Check equipment for shipping damage. If you find any damage, immediately contact the last carrier.

The following items may also be ordered separately:

- 1 - Thermostat
- 1 - Natural to LP gas conversion kit
- 1 - High altitude kit
- 1 - Horizontal suspension kit
- 1 -Sensor Kit (field installed)

⚠ DANGER

Danger of explosion.

There are circumstances in which odorant used with LP/propane gas can lose its scent. In case of a leak, LP/propane gas will settle close to the floor and may be difficult to smell. An LP/propane leak detector should be installed in all LP applications.

Safety Information

⚠ WARNING

Improper installation, adjustment, alteration, service or maintenance can cause property damage, personal injury or loss of life. Installation and service must be performed by a licensed professional installer (or equivalent), service agency or the gas supplier.

⚠ CAUTION

As with any mechanical equipment, contact with sharp sheet metal edges can result in personal injury. Take care while handling this equipment and wear gloves and protective clothing.

Use only the type of gas approved for use with this furnace. Refer to unit nameplate.

Building Codes

In the USA, installation of gas furnaces must conform with local building codes. In the absence of local codes, units must be installed according to the current National Fuel Gas Code (ANSI-Z223.1/NFPA 54). The National Fuel Gas Code is available from the following address:

American National Standards Institute, Inc.

11 West 42nd Street

New York, NY 10036

Installed Locations

In Canada, installation must conform with current National Standard of Canada CSA-B149 Natural Gas and Propane Installation Codes, local plumbing or waste water codes and other applicable local codes.

This furnace is designed for installation clearances to combustiblematerial as listed on the unit nameplate and in the tables in FIGURE 10 and FIGURE 11. Accessibility and service clearances must take precedence over fire protection clearances.

NOTE - For installation on combustible floors, the furnace shall not be installed directly on carpeting, tile, or other combustible material other than wood flooring.

For installation in a residential garage, the furnace must be installed so that the burner(s) and the ignition source are located no less than 18 inches (457 mm) above the floor. The furnace must be located or protected to avoid physical damage by vehicles. When a furnace is installed

in a public garage, hangar, or other building that has a hazardous atmosphere, the furnace must be installed according to recommended good practice requirements and current National Fuel Gas Code or CSA B149 standard.

NOTE - Furnace must be adjusted to obtain a temperature rise (100% percent capacity) within the range(s) specified on the unit nameplate. Failure to do so may cause erratic limit operation and may also result in premature heat exchanger failure. See “Duct System” on page 10 for installing the optional discharge air sensor used to measure temperature rise. Sensor is shipped with the unit.

This SLP99UHVK furnace must be installed so that its electrical components are protected from water.

Installed in Combination with a Cooling Coil

When this furnace is used with cooling units, it shall be installed in parallel with, or on the upstream side of, cooling units to avoid condensation in the heating compartment. With a parallel flow arrangement, a damper (or other means to control the flow of air) must adequately prevent chilled air from entering the furnace. If the damper is manually operated, it must be equipped to prevent operation of either the heating or the cooling unit, unless it is in the full HEAT or COOL setting. See FIGURE 3.

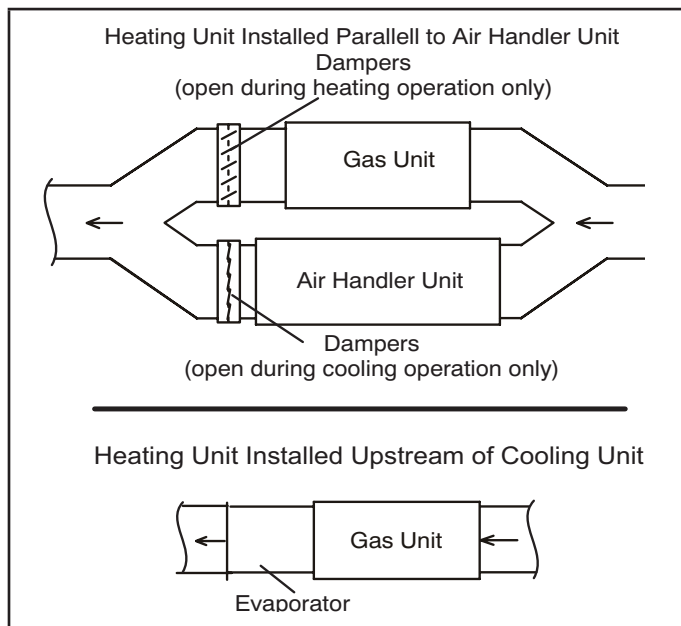

FIGURE 3

When installed, this furnace must be electrically grounded according to local codes. In addition, in the United States, installation must conform with the current National Electric Code, ANSI/NFPA No. 70. The National Electric Code (ANSI/NFPA No. 70) is available from the following address:

National Fire Protection Association
1 Battery March Park
Quincy, MA 02269

NOTE - This furnace is designed for a minimum continuous return air temperature of 60°F (16°C) or an intermittent operation down to 55°F (13°C) dry bulb for cases where a night setback thermostat is used. Return air temperature must not exceed 85°F (29°C) dry bulb.

In Canada, all electrical wiring and grounding for the unit must be installed according to the current regulations of the Canadian Electrical Code Part I (CSA Standard C22.1) and/or local codes.

CAUTION

Do not set thermostat below 60F (16C) in heating mode. Setting below 60F (16C) reduces the number of heating cycles. Damage to the unit may occur that is not covered by the warranty.

The SLP99UHVK furnace may be installed in alcoves, closets, attics, basements, garages, and utility rooms.

This furnace is not CSA International certified for installation in mobile homes, recreational vehicles, or outdoors.

Never use an open flame to test for gas leaks. Check all connections using a commercially available soap solution made specifically for leak detection.

Use of Furnace as Construction Heater

Units may be used for heating of buildings or structures under construction, if the following conditions are met to ensure proper operation:

DO NOT USE THE UNIT FOR CONSTRUCTION HEAT UNLESS ALL OF THE FOLLOWING CRITERIA ARE MET:

- Furnace must be in its final location. The vent system must be permanently installed per these installation instructions.
- Furnace must be installed as a two pipe system and one hundred percent (100%) outdoor air must be provided for combustion air requirements during construction.
- A room thermostat must control the furnace. The use of fixed jumpers that will provide continuous heating is prohibited.
- The input rate and temperature rise must be set per the furnace rating plate.
- Supply and Return air ducts must be provided and sealed to the furnace. Return air must be terminated outside of the space where furnace is installed.
- Return air temperature range between 60°F (16°C) and 80°F (27°C) must be maintained.
- MERV 11 or greater air filters must be installed in the system and must be regularly inspected and maintained (e.g., regular static checks and replaced at end of life) during construction.
- Blower and vestibule access panels must be in place on the furnace at all times.
- The furnace heat exchanger, components, duct system, and evaporator coils must be thoroughly cleaned following final construction clean-up.

- The refrigerant leak detection sensor must be inspected for dust/debris deposits. Please refer to the evaporator coil and/or refrigerant detection sensor kit instructions for additional information.
- Air filters must be replaced upon construction completion.
- All furnace operating conditions (including ignition, input rate, temperature rise and venting) must be verified in accordance with these installation instructions.

EQUIPMENT MAY EXPERIENCE PREMATURE COMPONENT FAILURE AS A RESULT OF FAILURE TO FOLLOW THE ABOVE INSTALLATION INSTRUCTIONS. FAILURE TO FOLLOW THE ABOVE INSTALLATION INSTRUCTIONS VOIDS THE MANUFACTURER'S EQUIPMENT LIMITED WARRANTY. LENNOX DISCLAIMS ALL LIABILITY IN CONNECTION WITH INSTALLER'S FAILURE TO FOLLOW THE ABOVE INSTALLATION INSTRUCTIONS.

NOTWITHSTANDING THE FOREGOING, INSTALLER IS RESPONSIBLE FOR CONFIRMING THAT THE USE OF CONSTRUCTION HEAT IS CONSISTENT WITH THE POLICIES AND CODES OF ALL REGULATING ENTITIES. ALL SUCH POLICIES AND CODES MUST BE ADHERED TO.

General

CAUTION
SLP99UHVK unit should not be installed in areas normally subject to freezing temperatures..

These instructions are intended as a general guide and do not supersede local codes in any way. Consult authorities having jurisdiction before installation.

In addition to the requirements outlined previously, the following general recommendations must be considered when installing a SLP99UHVK furnace:

- Place the furnace as close to the center of the air distribution system as possible. The furnace should also be located close to the chimney or vent termination point
- When the furnace is installed in an attic or other insulated space, keep insulation away from the furnace.
- When the furnace is installed in an unconditioned space, consider provisions required to prevent freezing of condensate drain system.
- Please consult the manufacturer of your evaporator coil for their recommendations on distance required between the heat exchanger and their drain pan. Adequate space must be provided between the drain pan and the furnace heat exchanger.

Installation - Setting Equipment

WARNING
Do not connect the return air ducts to the back of the furnace. Doing so will adversely affect the operation of the safety control devices, which could result in personal injury or death.

WARNING
Do not install the furnace on its front or back. See FIGURE 4.

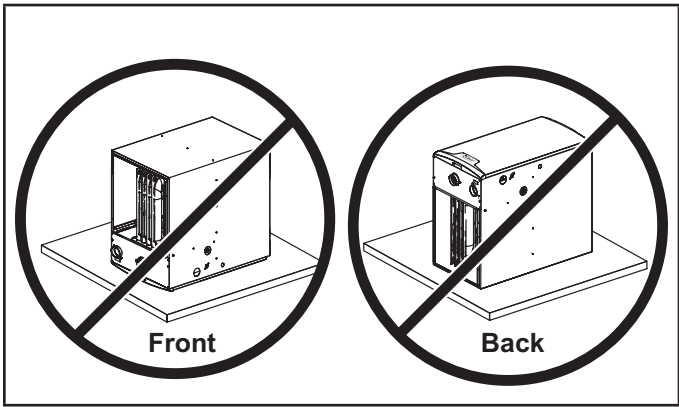

FIGURE 4

Upflow Applications

The SLP99UHVK gas furnace can be installed as shipped in the upflow position. Refer to FIGURE 10 for clearances. Select a location that allows for the required clearances that are listed on the unit nameplate. Also consider gas supply connections, electrical supply, vent connection, condensate trap and drain connections, and installation and service clearances [24 inches (610 mm) at unit front]. ***The unit must be level from side to side. Unit must be positioned with a slight slope up to 1/2" toward the front to aid in draining. See FIGURE 5.***

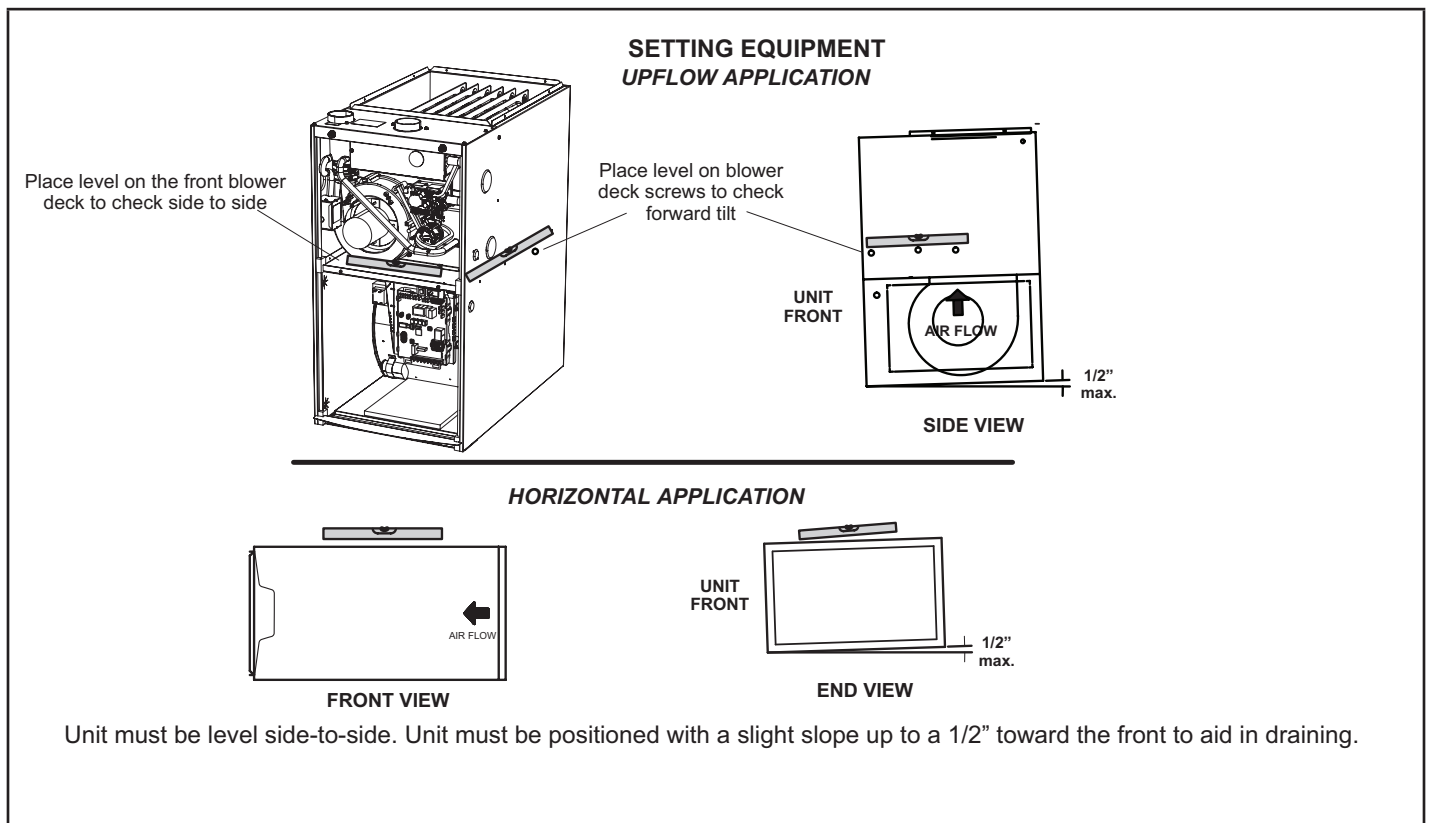

FIGURE 5

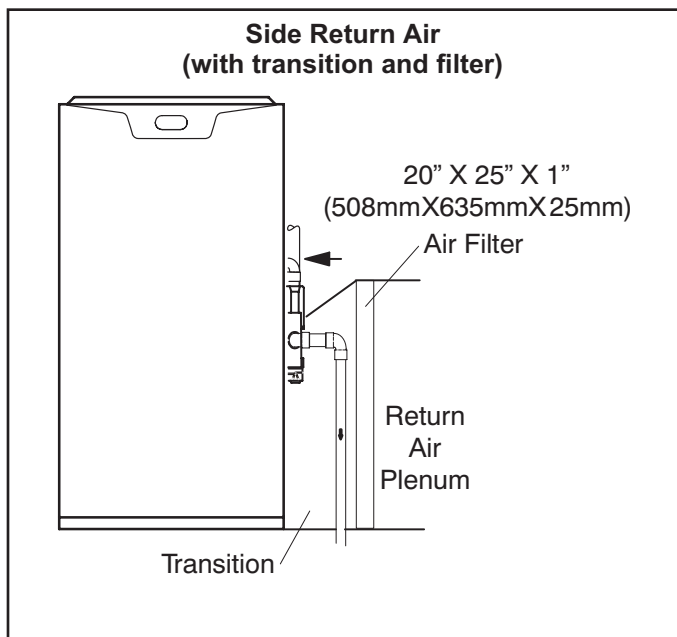

FIGURE 6

SLP99UHVK applications which include side return air and a condensate trap installed on the same side of the cabinet (trap can be installed remotely within 5 feet) require either a return air base or field-fabricated transition to accommodate an optional IAQ accessory taller than 14.5". See FIGURE 6.

Removing the Bottom Panel

Remove the two screws that secure the bottom cap to the furnace. Pivot the bottom cap down to release the bottom panel. Once the bottom panel has been removed, reinstall the bottom cap. See FIGURE 7.

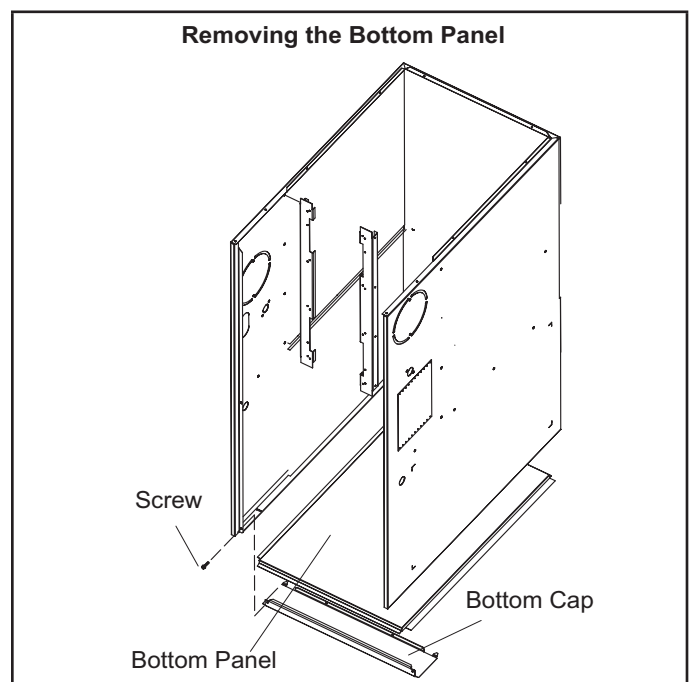

FIGURE 7

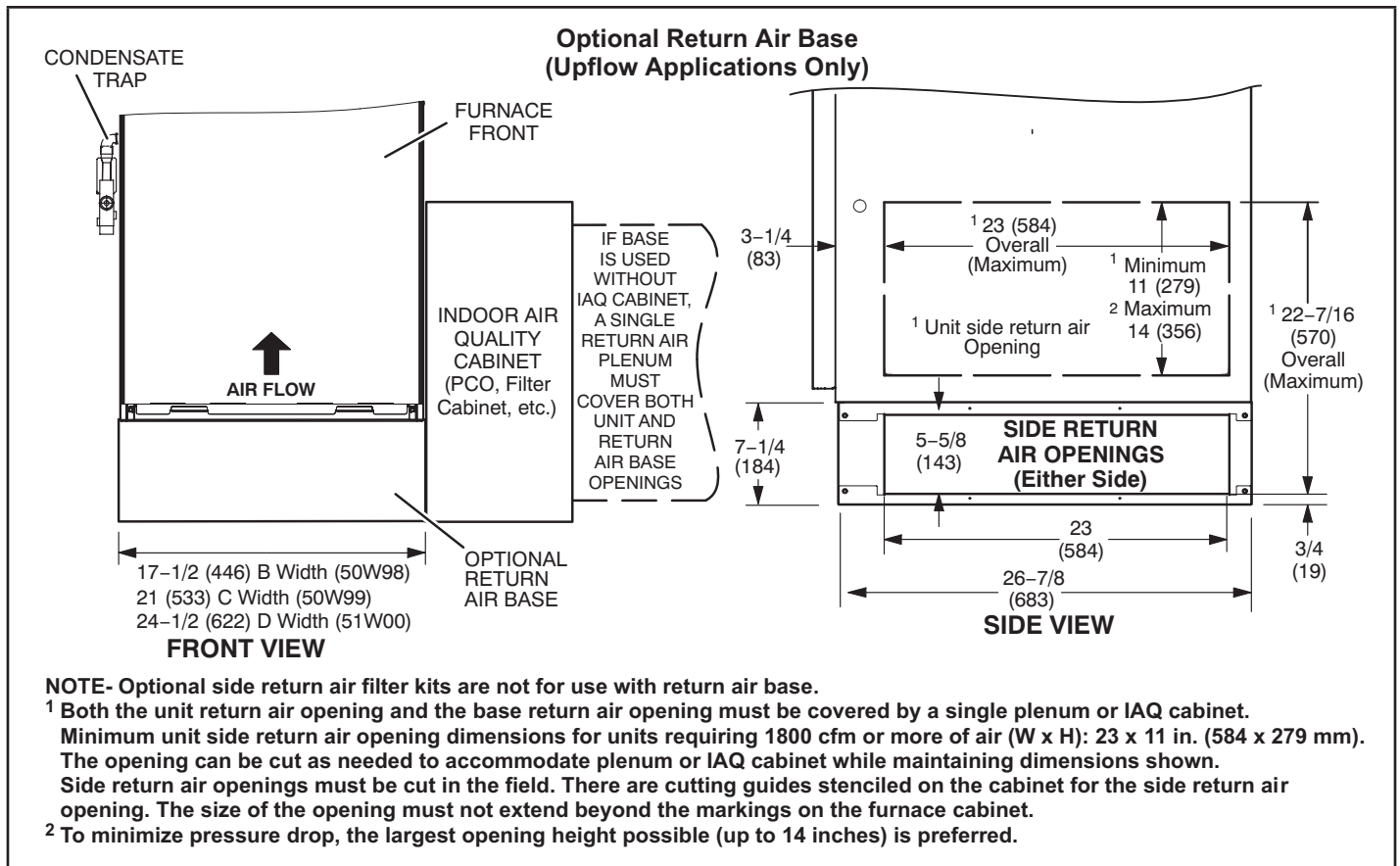

FIGURE 8

NOTE - Units with 1/2 hp blower motor are equipped with three flexible legs and one rigid leg. The rigid leg is equipped with a shipping bolt and a flat white plastic washer (rather than the rubber mounting grommet used with a flexible mounting leg). See FIGURE 9. **The bolt and washer must be removed before the furnace is placed into operation. After the bolt and washer have been removed, the rigid leg will not touch the blower housing.**

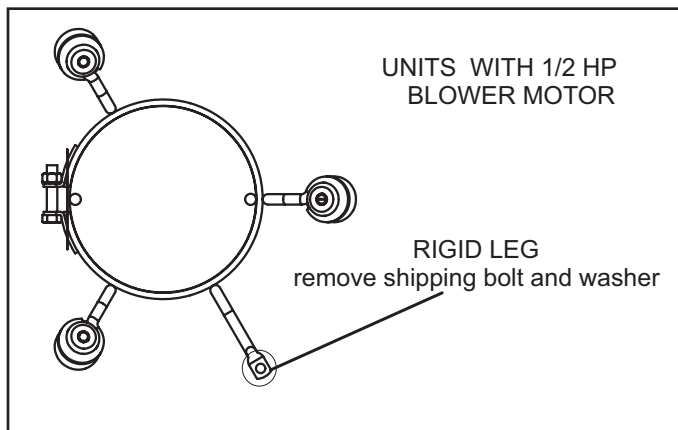

FIGURE 9

Allow for clearances to combustible materials as indicated on the unit nameplate. Minimum clearances for closet or alcove installations are shown in FIGURE 10 and FIGURE 11.

⚠ WARNING

The blower door must be securely in place when the blower and burners are operating. Gas fumes, which could contain carbon monoxide, can be drawn into the living space resulting in personal injury or death.

⚠ WARNING

Improper installation of the furnace can result in personal injury or death. Combustion and flue products must never be allowed to enter the return air system or air in the living space. Use sheet metal screws and joint tape to seal return air system to furnace.

In platform installations with furnace return, the furnace should be sealed airtight to the return air plenum. A door must never be used as a portion of the return air duct system. The base must provide a stable support and an airtight seal to the furnace. Allow absolutely no sagging, cracks, gaps, etc. For no reason should return and supply air duct systems ever be connected to or from other heating devices such as a fireplace or stove, etc. Fire, explosion, carbon monoxide poisoning, personal injury and/or property damage could result..

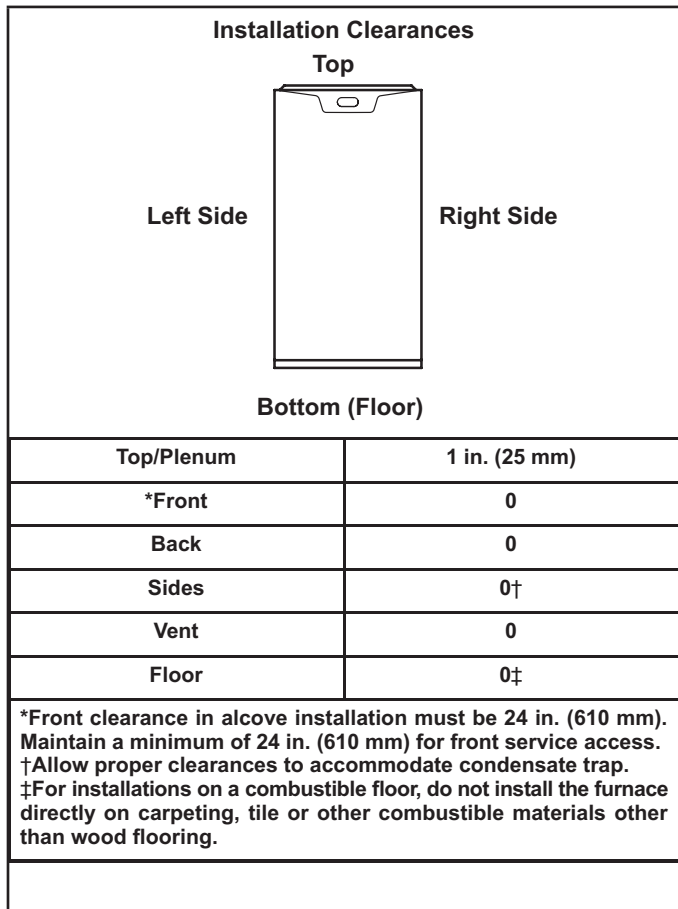

FIGURE 10

Return Air -- Upflow Units

Return air can be brought in through the bottom or either side of the furnace installed in an upflow application. If the furnace is installed on a platform with bottom return, make an airtight seal between the bottom of the furnace and the platform to ensure that the furnace operates properly and safely. The furnace is equipped with a removable bottom panel to facilitate installation.

Markings are provided on both sides of the furnace cabinet for installations that require side return air. Cut the furnace cabinet at the maximum dimensions shown on page 2. Refer to *Engineering Handbook* for additional information.

Setting an Upflow Unit

When the side return air inlets are used in an upflow application, it may be necessary to install shims on the bottom of the furnace.

Horizontal Applications

The SLP99UHVK furnace can be installed in horizontal applications with either right- or left-hand air discharge. Refer to FIGURE 11 for clearances in horizontal applications

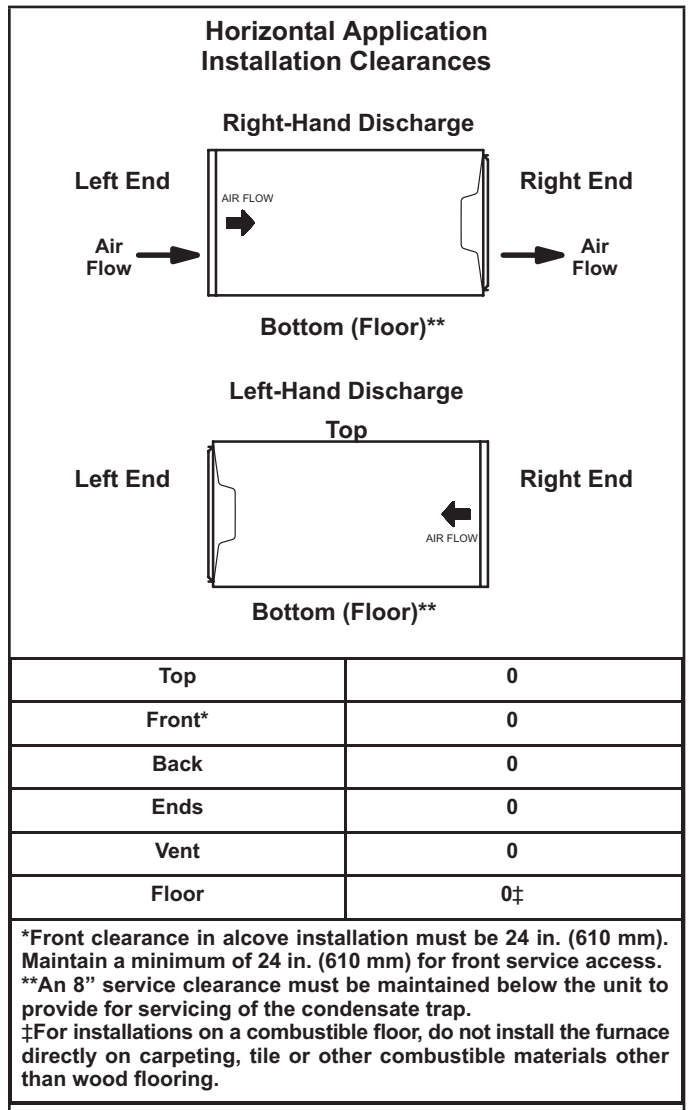

FIGURE 11

Suspended Installation of Horizontal Unit

This furnace may be installed in either an attic or a crawl-space. Either suspend the furnace from roof rafters or floor joists, as shown in FIGURE 12, or install the furnace on a platform, as shown in FIGURE 13. A horizontal suspension kit (51W10) may be ordered from Lennox or use equivalent.

NOTE - Heavy-gauge sheet metal straps may be used to suspend the unit from roof rafters or ceiling joists. When straps are used to suspend the unit in this way, support must be provided for both the ends. The straps must not interfere with the plenum or exhaust piping installation. **Cooling coils and supply and return air plenums must be supported separately.**

NOTE - When the furnace is installed on a platform in a crawlspace, it must be elevated enough to avoid water damage and to allow the evaporator coil to drain.

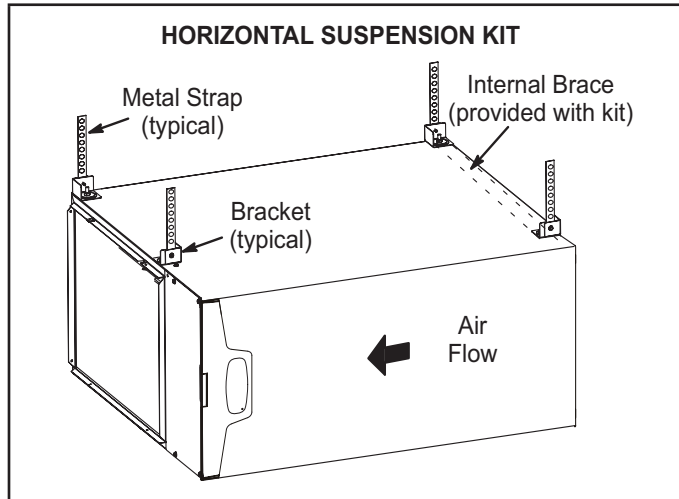

FIGURE 12

Platform Installation of Horizontal Unit

- 1 - Select location for unit keeping in mind service and other necessary clearances. See FIGURE 11.
- 2 - Construct a raised wooden frame and cover frame with a plywood sheet. If unit is installed above finished space, fabricate an auxiliary drain pan to be installed under unit. Set unit in drain pan as shown in FIGURE 13. Leave 8 inches for service clearance below unit for condensate trap.
- 3 - Provide a service platform in front of unit. When installing the unit in a crawl space, a proper support platform may be created using cement blocks.
- 4 - Route auxiliary drain line so that water draining from this outlet will be easily noticed by the homeowner.
- 5 - If necessary, run the condensate line into a condensate pump to meet drain line slope requirements. The pump must be rated for use with condensing furnaces. Protect the condensate discharge line from the pump to the outside to avoid freezing.
- 6 - Continue with exhaust, condensate and intake piping installation according to instructions.

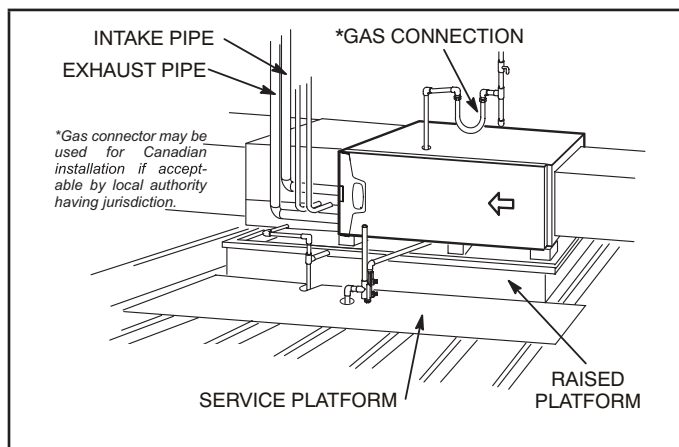

FIGURE 13

Return Air -- Horizontal Applications

Return air must be brought in through the end of a furnace installed in the horizontal position. The furnace is equipped with a removable bottom panel to facilitate installation. See FIGURE 7.

Filters

This unit is not equipped with a filter or rack. A field-provided filter is required for the unit to operate properly. TABLE 1 lists recommended filter sizes.

! IMPORTANT

If a highefficiency filter is being installed as part of this system to ensure better indoor air quality, the filter must be properly sized. Highefficiency filters have a higher static pressure drop than standard efficiency glass/foam filters. If the pressure drop is too great, system capacity and performance may be reduced. The pressure drop may also cause the limit to trip more frequently during the winter and the indoor coil to freeze in the summer, resulting in an increase in the number of service calls.

Before using any filter with this system, check the specifications provided by the filter manufacturer against the data given in the appropriate Lennox Product Specifications bulletin. Additional information is provided in Service and Application Note ACC002 (August 2000).

A filter must be in place when the unit is operating.

NOTE - In upflow applications where side return air filter is installed on same side as the condensate trap, make sure that clearance is maintained to ensure future access to the filter access panel.

TABLE 1

Furnace Cabinet Width	Filter Size	
	Side Return	Bottom Return
17-1/2"	16 X 25 X 1 (1)	16 X 25 X 1 (1)
21"	16 X 25 X 1 (1)	20 X 25 X 1 (1)
24-1/2"	16 X 25 X 1 (2)	24 X 25 X 1 (1)

Duct System

Use industry-approved standards to size and install the supply and return air duct system. This will result in a quiet and low-static system that has uniform air distribution. See below for proper duct installation.

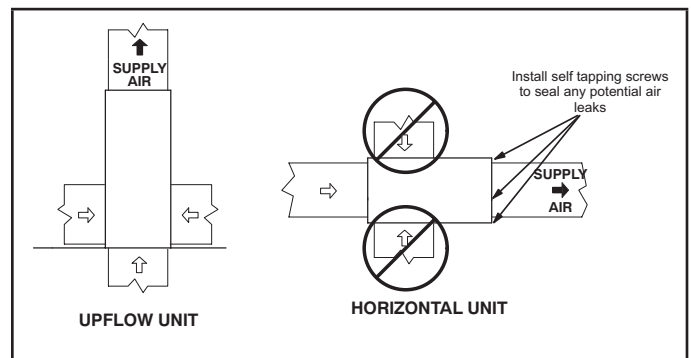

FIGURE 14

Discharge Air Temperature Sensor

This furnace is shipped with a discharge air temperature sensor that can be installed in the supply air plenum. The sensor is used to measure temperature rise in the heating mode and temperature drop in the cooling mode. See TABLE 2 and FIGURE 15 (upflow) or TABLE 3 and FIGURE 16 (horizontal left) or TABLE 4 and FIGURE 17 (horizontal right) for correct location. Drill a 3/8 inch diameter hole in the supply duct based on the specified location. Center the discharge air temperature sensor in the middle of the hole and use two field provided screws to secure in place. The orientation of the sensor mounting flange is not critical and can be oriented to whatever position is needed to prevent interference with the evaporator coil, air duct etc. Field supplied wiring must be used to connect the discharge air temperature sensor to the discharge air temperature sensor terminals on the integrated control board. Either wire can be connected to either terminal. See FIGURE 18.

A communicating thermostat can be used to run temperature rise and temperature drop tests and viewed in the installation reports. See "FIGURE 53" on page 36 for communicating thermostat wiring. If a communicating thermostat is not being used, then the discharge temperature can be viewed on the seven segment LED on the integrated control shown in FIGURE 18. For zoning applications the discharge air sensor must be installed and wired to the zoning control board and should not be wired to the furnace control board.

NOTE - The discharge air temperature sensor must be located per TABLE 2, TABLE 3 or TABLE 4 to provide an accurate temperature measurement.

NOTE - If the system does not include an evaporation coil, the sensor should be installed according to the following:

1 - Place the sensor as far away from the direct heat source in the main plenum as possible. A minimum of 19" is recommended but up to 36" is preferred.

2 - Offset the sensor 1/4 of the width of the plenum from the left edge of the plenum in upflow, top edge of the plenum in horizontal right and bottom of the plenum in horizontal left. For example, if the plenum is 16" wide then offset the sensor 4" from the edge. The sensor should report a temperature within the rise range of the furnace. If the readings from the sensor appear to be below the rise range of the furnace, move the sensor in 1" increments towards the center of the plenum until the sensed temperature is within the rise range of the furnace. If the sensor reading appears to be too high, move the sensor in 1" increments towards the edge of the plenum until the sensed temperature is within the rise range of the furnace.

TABLE 2

Discharge Air Temperature Sensor Location Upflow

SLP99UHK Model	"a"	"b"	Mounting Surface
070XV36B	2"	Center	Plenum Duct
090XV36C	3"	Center	
090XV48C	2"	7" from right	
090XV60C	3"	4" from left	
110XV60C	2"	8" from right	
135XV60D	2"	7" from left	

Discharge Air Temperature Sensor Location

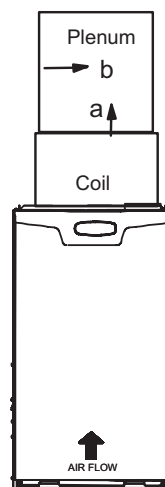

Upflow

FIGURE 15

TABLE 3
Discharge Air Temperature Sensor
Location Horizontal Left

SLP99UHK Model	"a"	"b"	Mounting Surface
070XV36B	5"	Center	Plenum Duct
090XV36C	3"	4" from bottom	
090XV48C	2"	7" from bottom	
090XV60C	4"	3" from bottom	
110XV60C	3"	8" from bottom	
135XV60D	2"	7" from bottom	

TABLE 4
Discharge Air Temperature Sensor
Location Horizontal Right

SLP99UHK Model	"a"	"b"	Mounting Surface
070XV36B	5"	Center	Plenum Duct
090XV36C	2"	8" from bottom	
090XV48C	3"	Center	
090XV60C	3"	7" from top	
110XV60C	3"	Center	
135XV60D	2"	7" from top	

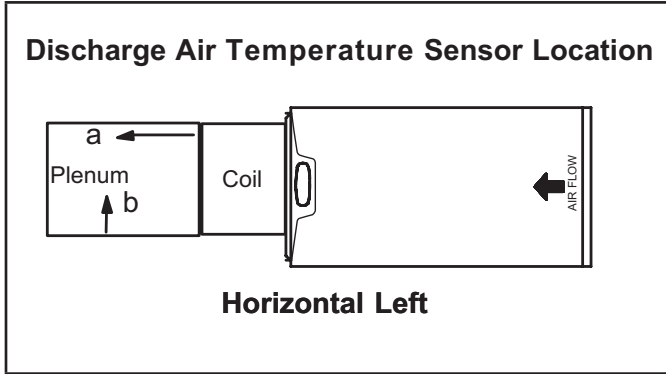

FIGURE 16

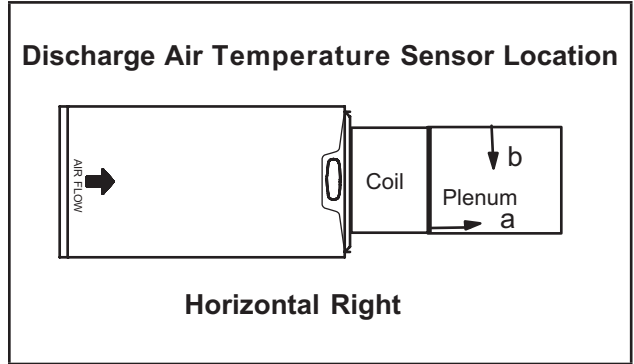

FIGURE 17

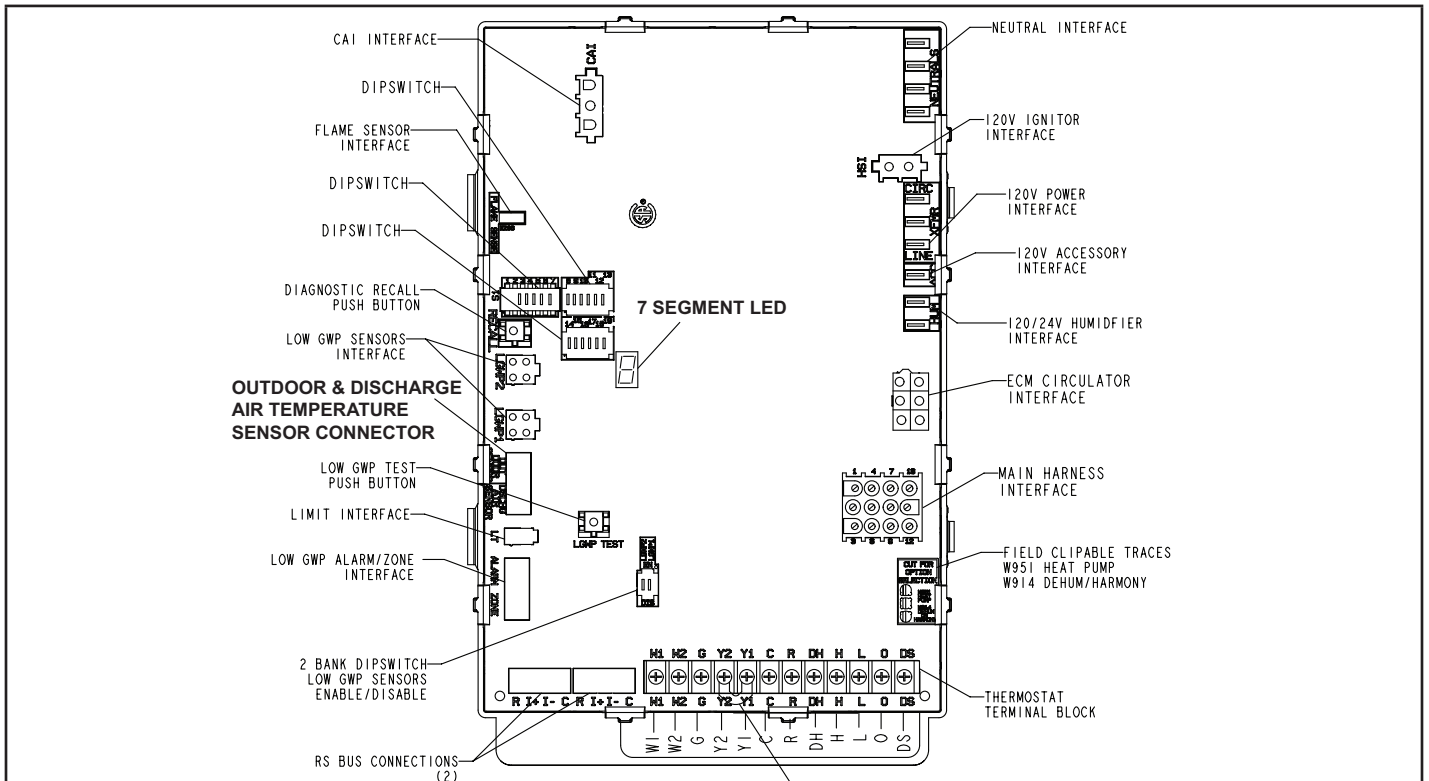

FIGURE 18

NOTE - Operation of this furnace in heating mode (indoor blower operating at selected heating speed) with an external static pressure which exceeds 0.8 inches w.c. may result in erratic limit operation.

Supply Air Plenum

If the furnace is installed without a cooling coil, a removable access panel should be installed in the supply air duct. The access panel should be large enough to permit inspection (by reflected light) of the heat exchanger for leaks after the furnace is installed. If present, this access panel must always be in place when the furnace is operating and it must not allow leaks into the supply air duct system. In horizontal units, install self tapping screws in the three evaporator coil screw holes made for upflow applications to seal the top cap to the vestibule panel.

Return Air Plenum

Return air must not be drawn from a room where this furnace, or any other gas-fueled appliance (i.e., water heater), or carbon monoxide-producing device (i.e., wood fireplace) is installed. When return air is drawn from a room, a negative pressure is created in the room. If a gas appliance is operating in a room with negative pressure, the flue products can be pulled back down the vent pipe and into the room. This reverse flow of the flue gas may result in incomplete combustion and the formation of carbon monoxide gas. This toxic gas might then be distributed throughout the house by the furnace duct system.

Return air can be brought in through the bottom or either side of the furnace (return air brought in through either side of the furnace allowed in upflow applications only). If a furnace with bottom return air is installed on a platform, make an airtight seal between the bottom of the furnace and the platform to ensure that the unit operates properly and safely. Use fiberglass sealing strips, caulking, or equivalent sealing method between the plenum and the furnace cabinet to ensure a tight seal. If a filter is installed, size the return air duct to fit the filter frame.

Pipe Fittings Specifications

All pipe, fittings, primer and solvent cement must conform with American National Standard Institute and the American Society for Testing and Materials (ANSI/ASTM) standards. The solvent shall be free-flowing and contain no lumps, undissolved particles or any foreign matter that adversely affects the joint strength or chemical resistance of the cement. The cement shall show no gelation, stratification, or separation that cannot be removed by stirring. Refer to TABLE 5 for approved piping and fitting materials.

IMPORTANT

SLP99UHVK exhaust and intake connections are made of PVC. Use PVC primer and solvent cement when using PVC vent pipe. When using ABS vent pipe, use transitional solvent cement to make connections to the PVC fittings in the unit.

**TABLE 5
PIPING AND FITTINGS SPECIFICATIONS**

Schedule 40 PVC (Pipe)	D1785
Schedule 40 PVC (Fittings)	D2466
Schedule 40 CPVC (Pipe)	F441
Schedule 40 CPVC (Fittings)	F438
SDR-21 PVC or SDR-26 PVC (Pipe)	D2241
SDR-21 CPVC or SDR-26 CPVC (Pipe)	F442
Schedule 40 ABS (Pipe)	D1527
Schedule 40 ABS (Fittings)	D2468
ABS-DWV (Drain Waste & Vent) (Pipe & Fittings)	D2661
PVC-DWV (Drain Waste & Vent) Pipe & Fittings)	D2665
PVC Pipe and Fittings	IPEX UL1738
PRIMER & SOLVENT CEMENT	ASTM SPECIFICATION
PVC & CPVC Primer	F656
PVC Solvent Cement	D2564
CPVC Solvent Cement	F493
ABS Solvent Cement	D2235
PVC Solvent Cement	IPEX UL1738
PVC/CPVC/ABS All Purpose Cement For Fittings & Pipe of the same material	D2564, D2235, F493
ABS to PVC or CPVC Transition Solvent Cement	D3138
ABS to PVC Transition Solvent Cement	IPEX UL1738
CANADA PIPE & FITTING & SOLVENT CEMENT	MARKING
PVC & CPVC Pipe and Fittings	ULCS636
PVC & CPVC Solvent Cement	
ABS to PVC or CPVC Transition Cement	
POLYPROPYLENE VENTING SYSTEM	ULCS636
PolyPro® by Duravent	
InnoFlue® by Centrotherm	
ECCO Polypropylene Vent™	UL1738
UL 1738 CERTIFIED GAS VENTING SYSTEM	
IPEX System1738 Schedule 40 PVC Pipes and Fittings	
IPEX System1738 PVC FGV Cement & Primer	

CAUTION

Solvent cements for plastic pipe are flammable liquids and should be kept away from all sources of ignition. Do not use excessive amounts of solvent cement when making joints. Good ventilation should be maintained to reduce fire hazard and to minimize breathing of solvent vapors. Avoid contact of cement with skin and eyes.

Use PVC primer and solvent cement or ABS solvent cement meeting ASTM specifications, refer to TABLE 5. As an alternate, use all purpose cement, to bond ABS, PVC, or CPVC pipe when using fittings and pipe made of the same materials. Use transition solvent cement when bonding ABS to either PVC or CPVC. Low temperature solvent cement is recommended. Metal or plastic strapping may be used for vent pipe hangers. Uniformly apply a liberal coat of PVC primer for PVC.

**TABLE 6
OUTDOOR TERMINATION USAGE***

Input Size	Vent Pipe Dia. in.	STANDARD					CONCENTRIC		
		Flush Mount Kit	Wall Kit		Wall Ring Kit	Field Fabricated	1-1.2 inch	2 inch	3 inch
			2 inch	3 inch	2 inch				
		51W11 (US) 51W12 (CA)	22G44 (US) 430G28 (CA)	44J40 (US) 481J20 (CA)	15F74	71M80 (US) 44W92 (CA)	69M29 (US) 44W92 (CA)	60L46 (US) 44W93 (CA)	
070	61-1/2	3YES	YES	1YES	1YES	5YES	2YES		
	2	3YES	YES	1YES	1YES	5YES	2YES		
	2-1/2	3YES	YES	1YES	1YES	5YES	2YES		
	3	3YES	YES	1YES	1YES	5YES	2YES		
090	2	3YES		YES	YES	5YES		YES YES	
	2-1/2	3YES		YES	YES	5YES		YES YES	
	3	3YES		YES	YES	5YES		YES YES	
110	2	YES		YES	YES	5YES		YES YES	
	2-1/2	YES		YES		5YES		YES YES	
	3	YES		YES		5YES		YES YES	
135	3	YES		YES		5YES		YES	

NOTE - Standard Terminations do not include any vent pipe or elbows external to the structure. Any vent pipe or elbows external to the structure must be included in total vent length calculations. See vent length tables.
 * Kits must be properly installed according to kit instructions.
 1Requires field-provided outdoor 1-1/2" exhaust accelerator.
 2Concentric kits 71M80 and 44W92 include 1-1/2 in. outdoor accelerator, when used with 070 input models. When 1-1/2 in. pipe is used it must transition to 2 in. pipe with the concentric kit.
 3 Flush mount kits 51W11 and 51W12 includes 1-1/2 in. outdoor exhaust accelerator, required when used with 070 and 090 input models. When 1-1/2 in. pipe is used it must transition to 2 in. pipe with the flush mount kit.
 4 Termination kits 30G28, 44W92, 4493 and 81J20 are certified to ULC S636 for use in Canada only.
 5 See table 10 for vent accelerator requirements.
 6 2 in. to 1-1/2 in. **field provided** reducer required.

Joint Cementing Procedure

All cementing of joints should be done according to the specifications outlined in ASTM D 2855.

NOTE - A sheet metal screw may be used to secure the intake pipe to the connector, if desired. Use a drill or self tapping screw to make a pilot hole.

⚠ DANGER
 Fumes from PVC glue may ignite during system check. Allow fumes to dissipate for at least 5 minutes before placing unit into operation.

- 1 - Measure and cut vent pipe to desired length.
- 2 - Debur and chamfer end of pipe, removing any ridges or rough edges. If end is not chamfered, edge of pipe may remove cement from fitting socket and result in a leaking joint.

NOTE - Check the inside of vent pipe thoroughly for any obstruction that may alter furnace operation.

- 3 - Clean and dry surfaces to be joined.
- 4 - Test fit joint and mark depth of fitting on outside of pipe.
- 5 - Uniformly apply a liberal coat of PVC primer for PVC or use a clean dry cloth for ABS to clean inside socket surface of fitting and male end of pipe to depth of fitting socket.
- 6 - Promptly apply solvent cement to end of pipe and inside socket surface of fitting. Cement should be applied lightly but uniformly to inside of socket. Take care to keep excess cement out of socket. Apply second coat to end of pipe.

NOTE - Time is critical at this stage. Do not allow primer to dry before applying cement.

- 7 - Immediately after applying last coat of cement to pipe, and while both inside socket surface and end of pipe are wet with cement, forcefully insert end of pipe into socket until it bottoms out. Turn PVC pipe 1/4 turn during assembly (but not after pipe is fully inserted) to distribute cement evenly. DO NOT turn ABS or cellular core pipe.

NOTE - Assembly should be completed within 20 seconds after last application of cement. Hammer blows should not be used when inserting pipe.

- 8 - After assembly, wipe excess cement from pipe at end of fitting socket. A properly made joint will show a bead around its entire perimeter. Any gaps may indicate a defective assembly due to insufficient solvent.
- 9 - Handle joints carefully until completely set.

Venting Practices

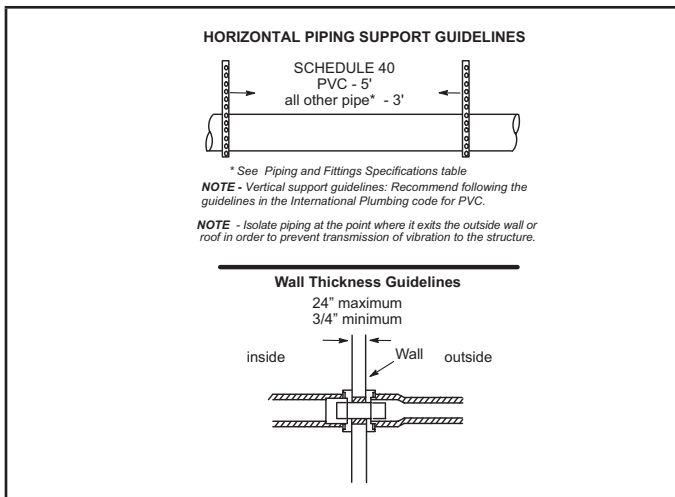

FIGURE 19

- 1 - In areas where piping penetrates joists or interior walls, hole must be large enough to allow clearance on all sides of pipe through center of hole using a hanger.
- 2 - When furnace is installed in a residence where unit is shut down for an extended period of time, such as a vacation home, make provisions for draining condensate collection trap and lines.

Exhaust Piping FIGURE 23, FIGURE 24 and FIGURE 26 (vent adapter)

- 3 - Route piping to outside of structure. Continue with installation following instructions given in piping termination section.

Intake Piping FIGURE 23 and FIGURE 24

The SLP99UHVK furnace may be installed only in direct vent applications. The SLP99UHVK is designed for combustion air intake through an inlet in the unit's top cap. Intake air piping is independent of exhaust piping.

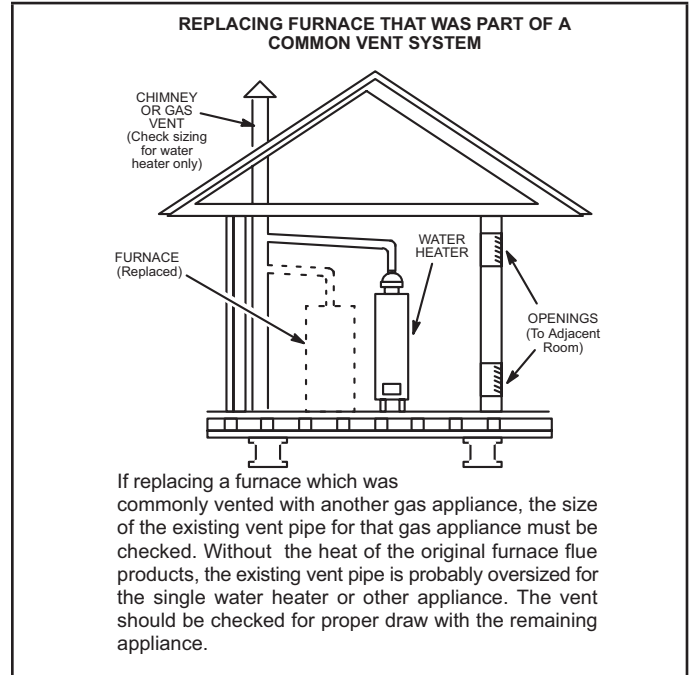

FIGURE 20

! CAUTION

Do not discharge exhaust into an existing stack or stack that also serves another gas appliance. If vertical discharge through an existing unused stack is required, insert PVC pipe inside the stack until the end is even with the top or outlet end of the metal stack.

! CAUTION

The exhaust vent pipe operates under positive pressure and must be completely sealed to prevent leakage of combustion products into the living space.

Vent Pipe Guidelines

NOTE - Lennox has approved the use of DuraVent® and Centrotherm vent pipe and terminations as an option to PVC. When using the PolyPro® by DuraVent or InnoFlue® by Centrotherm venting system the vent pipe requirements stated in the unit installation instruction – minimum & maximum vent lengths, termination clearances, etc. – apply and must be followed. Follow the instructions provided with PolyPro by DuraVent and InnoFlue® by Centrotherm venting system for assembly or if requirements are more restrictive. The PolyPro by DuraVent and InnoFlue by Centrotherm venting system must also follow the uninsulated and unconditioned space criteria listed in TABLE 9.

The SLP99UHVK is installed only as a Direct Vent gas central furnace.

NOTE - In Direct Vent installations, combustion air is taken from outdoors and flue gases are discharged outdoors. Intake and exhaust pipe sizing -- Size pipe according to TABLE 7 and TABLE 8. Count all elbows inside and outside the home.

Regardless of the diameter of pipe used, the standard roof and wall terminations described in section Exhaust Piping Terminations should be used. Exhaust vent termination pipe is sized to optimize the velocity of the exhaust gas as it exits the termination. Refer to TABLE 10.

In some applications which permit the use of several different sizes of vent pipe, a combination vent pipe may be used. Contact Lennox' Application Department for assistance in sizing vent pipe in these applications.

Use the steps in FIGURE 22 to correctly size vent pipe diameter.

NOTE - It is acceptable to use any pipe size which fits within the guidelines allowed in TABLE 8.

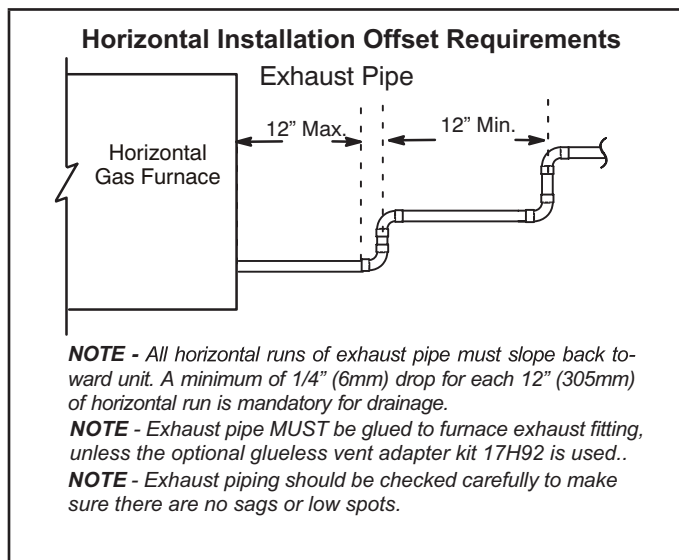

FIGURE 21

NOTE - The exhaust collar on all models is sized to accommodate 2" Schedule 40 vent pipe. In horizontal applications, any transition to exhaust pipe larger than 2" must be made in vertical runs of the pipe. Therefore a 2" elbow must be added before the pipe is transitioned to any size larger than 2". This elbow must be added to the elbow count used to determine acceptable vent lengths. Contact the Application Department for more information concerning sizing of vent systems which include multiple pipe sizes.

NOTE - Lennox offers a glueless vent adapter kit 17H92 as an option for exhaust exiting at the furnace top cap coupling. If the kit is not used the exhaust pipe MUST be glued to furnace exhaust fitting.

! IMPORTANT
 Do not use screens or perforated metal in exhaust or intake terminations. Doing so will cause freeze-ups and may block the terminations..

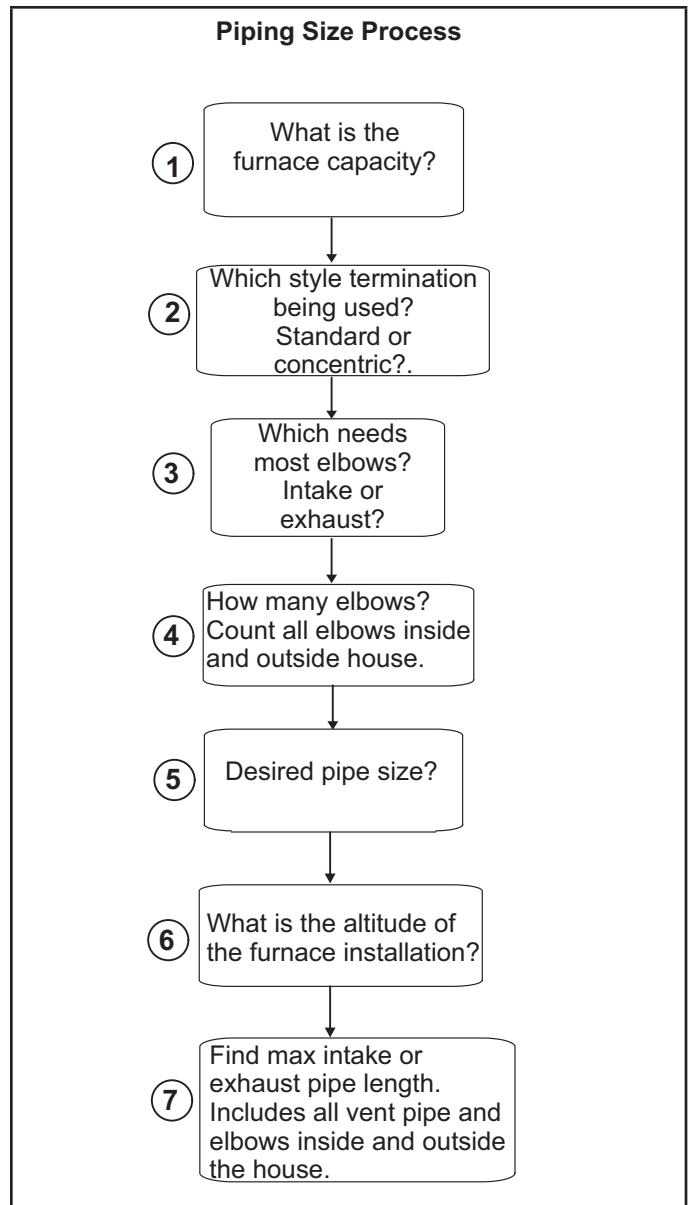

FIGURE 22

TABLE 7
 MINIMUM VENT PIPE LENGTHS

SLP99UHVK MODEL	MIN.EQUIV. VENT LENGTH	EXAMPLE
070	15 ft*	5 ft. plus 2 elbows of 1-1/2", 2", 2-1/2" or 3" diameter pipe
090, 110		5 ft. plus 2 elbows of 2", 2-1/2" or 3" diameter pipe
135		5 ft. plus 2 elbows of 3" diameter pipe

*Any approved termination may be added to the minimum equivalent length listed. Two 45 degree elbows are the equivalent to one 90 degree elbow.

TABLE 8

Maximum Allowable Intake or Exhaust Vent Length in Feet

*Size intake and exhaust pipe length separately. Values in table are for Intake OR Exhaust, not combined total. Both Intake and Exhaust must be same pipe size.

NOTE - Additional vent pipe and elbows used to terminate the vent pipe outside the structure must be included in the total vent length calculation.

Standard Termination at Elevation 0 - 7500'																
Number Of 90° Elbows Used	1-1/2" Pipe				2" Pipe				2-1/2" Pipe				3" Pipe			
	Model				Model				Model				Model			
	070	090	110	135	070	090	110	135	070	090	110	135	070	090	110	135
1	20	N/A	N/A	N/A	91	69	14	N/A	140	93	43	N/A	162	143	118	114
2	15				86	64	9		135	88	38		157	138	113	109
3	10				81	59	N/A		130	83	33		152	133	108	104
4	N/A				76	54			125	78	28		147	128	103	99
5					71	49			120	73	23		142	123	98	94
6					66	44			115	68	18		137	118	93	89
7					61	39			110	63	13		132	113	88	84
8					56	34			105	58	N/A		127	108	83	79
9					51	29			100	53			122	103	78	74
10					46	24			95	48	117		98	73	69	
Standard Termination at Elevation 7501' - 10,000'																
Number of 90° Elbows Used	1-1/2" Pipe				2" Pipe				2-1/2" Pipe				3" Pipe			
	Model				Model				Model				Model			
	070	090	110	135	070	090	110	135	070	090	110	135	070	090	110	135
1	12	N/A	N/A	N/A	66	44	N/A	N/A	115	68	N/A	N/A	137	118	93	89
2	7				61	39			110	63			132	113	88	84
3	N/A				56	34			105	58			127	108	83	79
4					51	29			100	53			122	103	78	74
5					46	24			95	48			117	96	73	69
6					41	19			90	43			112	93	68	64
7					36	14			85	38			107	88	63	59
8					31	N/A			80	33			102	83	58	54
9					26				75	28			97	78	53	49
10					21				70	23			92	73	48	44

TABLE 8 Cont.

Maximum Allowable Intake or Exhaust Vent Length in Feet

*Size intake and exhaust pipe length separately. Values in table are for Intake OR Exhaust, not combined total. Both Intake and Exhaust must be same pipe size.

NOTE - Additional vent pipe and elbows used to terminate the vent pipe outside the structure must be included in the total vent length calculation

Concentric Termination 0 - 7501"																
Number of 90° Elbows Used	1-1/2" Pipe				2" Pipe				2-1/2" Pipe				3" Pipe			
	Model				Model				Model				Model			
	070	090	110	135	070	090	110	135	070	090	110	135	070	090	110	135
1	15	N/A	N/A	N/A	83	67	12	N/A	130	89	39	N/A	146	139	114	105
2	10				78	62	7		125	84	34		141	134	109	100
3	N/A				73	57	N/A		120	79	29		136	129	104	95
4					68	52			115	74	24		131	124	99	90
5					63	47			110	69	19		126	119	94	85
6					58	42			105	64	14		121	114	89	80
7					53	37			100	59	N/A		116	109	84	75
8					48	32			95	54			111	104	79	70
9					43	27			90	49			106	99	74	65
10					38	22			85	44	101		94	69	60	
Concentric Termination 7501" - 10,000"																
Number of 90° Elbows Used	1-1/2" Pipe				2" pipe				2-1/2" Pipe				3" Pipe			
	Model				Model				Model				Model			
	070	090	110	135	070	090	110	135	070	090	110	135	070	090	110	135
1	10	N/A	N/A	N/A	58	42	N/A	N/A	105	64	N/A	N/A	121	114	89	80
2	N/A				53	37			100	59			116	109	84	75
3					48	32			95	54			111	104	79	70
4					43	27			90	49			106	99	74	65
5					38	22			85	44			101	94	69	60
6					33	17			80	39			96	89	64	55
7					28	12			75	34			91	84	59	50
8					23	N/A			70	29			86	79	54	45
9					18				65	24			81	74	49	40
10	13				60				19	76			69	44	35	

TYPICAL EXHAUST AND INTAKE PIPE CONNECTIONS IN UPFLOW

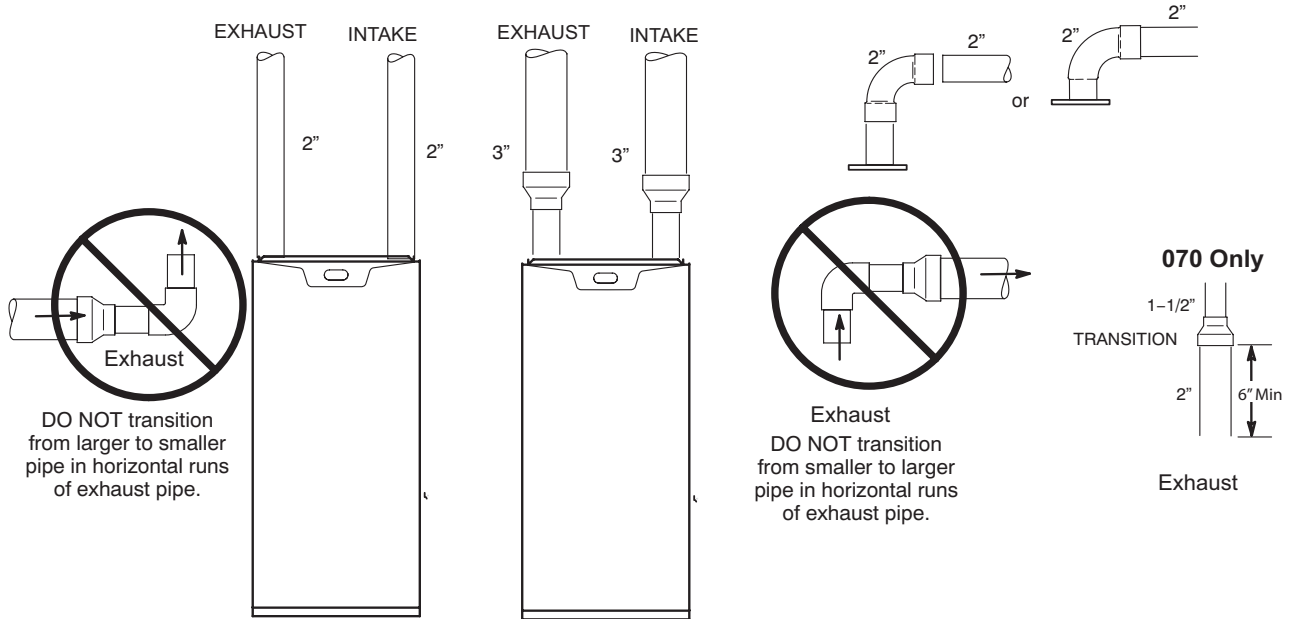

* When transitioning up in pipe size, use the shortest length of 2" PVC pipe possible.
 NOTE - Exhaust pipe and intake pipe must be the same diameter.

FIGURE 23

**TYPICAL EXHAUST AND INTAKE PIPE CONNECTIONS IN HORIZONTAL
 (RIGHT HAND DISCHARGE SHOWN)**

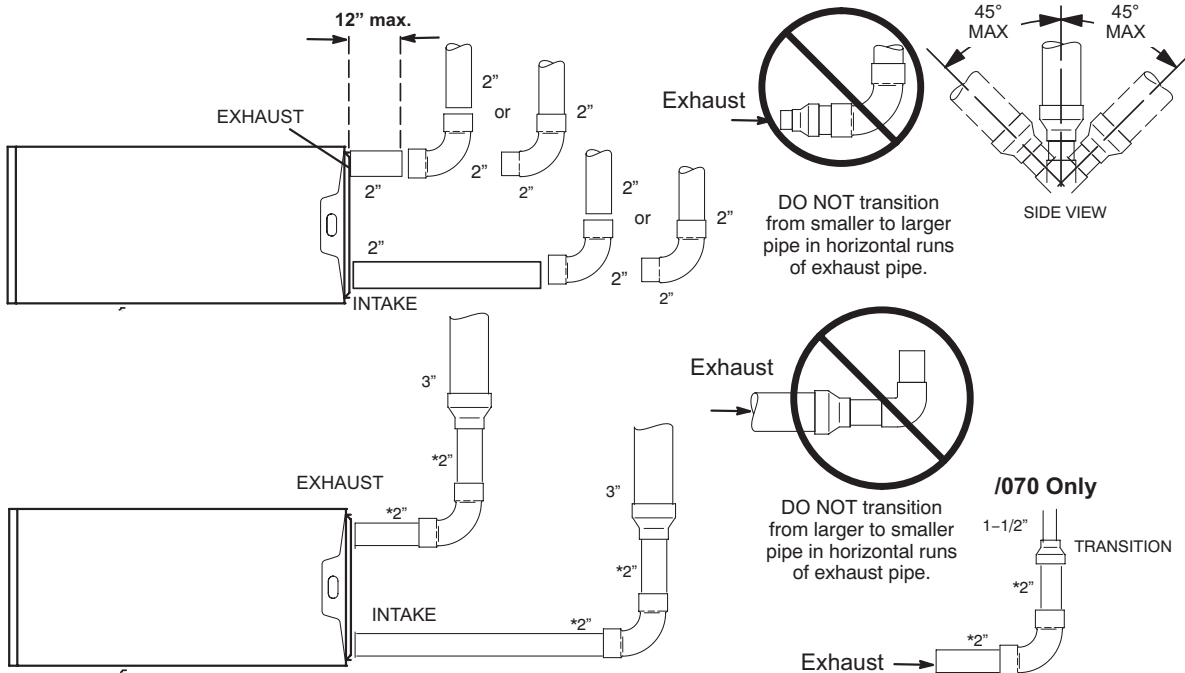

* When transitioning up in pipe size, use the shortest length of 2" PVC pipe possible.
 NOTE - Exhaust pipe and intake pipe must be the same diameter.

FIGURE 24

VENT TERMINATION CLEARANCES FOR DIRECT VENT INSTALLATIONS IN THE US AND CANADA

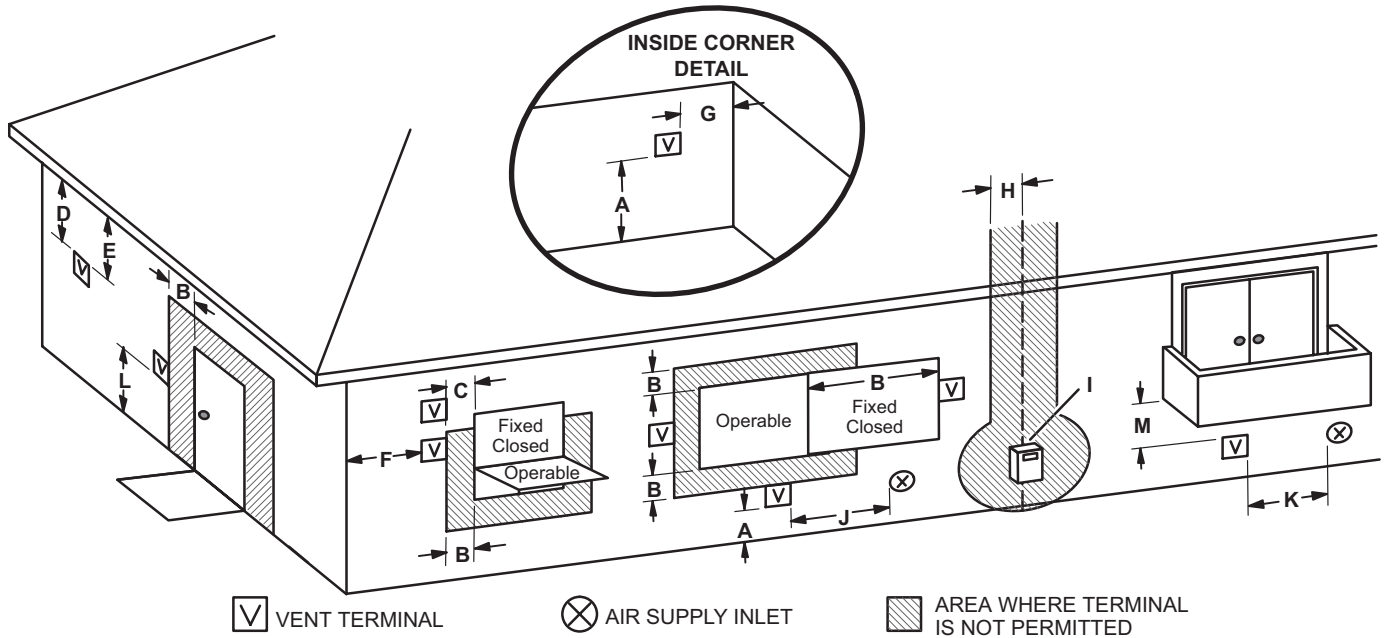

	US Installations ¹	Canadian Installations ²
A =	Clearance above grade, veranda, porch, deck or balcony	12 inches (305mm) or 12 in. (305mm) above average snow accumulation.
B =	Clearance to window or door that may be opened	6 inches (152mm) for appliances <10,000 Btuh (3kw), 9 inches (228mm) for appliances > 10,000 Btuh (3kw) and <50,000 Btuh (15 kw), 12 inches (305mm) for appliances > 50,000 Btuh (15kw)
C =	Clearance to permanently closed window	* 12"
D =	Vertical clearance to ventilated soffit located above the terminal within a horizontal distance of 2 feet (610mm) from the center line of the terminal	* Equal to or greater than soffit depth
E =	Clearance to unventilated soffit	* Equal to or greater than soffit depth
F =	Clearance to outside corner	* No minimum to outside corner
G =	Clearance to inside corner	*
H =	Clearance to each side of center line extended above meter / regulator assembly	3 feet (.9m) within a height 15 feet (4.5m) above the meter / regulator assembly
I =	Clearance to service regulator vent outlet	* 3 feet (.9m)
J =	Clearance to non-mechanical air supply inlet to building or the combustion air inlet to any other appliance	6 inches (152mm) for appliances <10,000 Btuh (3kw), 9 inches (228mm) for appliances > 10,000 Btuh (3kw) and <50,000 Btuh (15 kw), 12 inches (305mm) for appliances > 50,000 Btuh (15kw)
K =	Clearance to mechanical air supply inlet	3 feet (.9m) above if within 10 feet (3m) horizontally
L =	Clearance above paved sidewalk or paved driveway located on public property	* 7 feet (2.1m)
M =	Clearance under veranda, porch, deck or balcony	*12 inches (305mm)‡

¹ In accordance with the current ANSI Z223.1/NFPA 54 Natural Fuel Gas Code

² In accordance with the current CSA B149.1, Natural Gas and Propane Installation Code

† A vent shall not terminate directly above a sidewalk or paved driveway that is located between two single family dwellings and serves both dwellings.

‡ Permitted only if veranda, porch, deck or balcony is fully open on a minimum of two sides beneath the floor. Lennox recommends avoiding this location if possible.

*For clearances not specified in ANSI Z223.1/NFPA 54 or CSA B149.1, clearance will be in accordance with local installation codes and the requirements of the gas supplier and these installation instructions."

NOTE - This figure is intended to illustrate clearance requirements and does not serve as a substitute for locally adopted installation codes.

FIGURE 25

Flue Coupling

The provided flue coupling must be attached to the exhaust coupling on the furnace top panel. Use provided bands. See steps below. and FIGURE 26.

- 1 - Remove the caution tag from the flue coupling.
- 2 - Fully insert flue coupling with both bands loosely attached on the furnace exhaust coupling.
- 3 - Insert PVC exhaust pipe through flue coupling. Ensure vent pipe is fully seated into exhaust coupling.
- 4 - Tighten both top and bottom bands to 40in-lbs.

NOTE - Do not use any type of glue or silicone to attach the flue coupling to the furnace exhaust coupling.

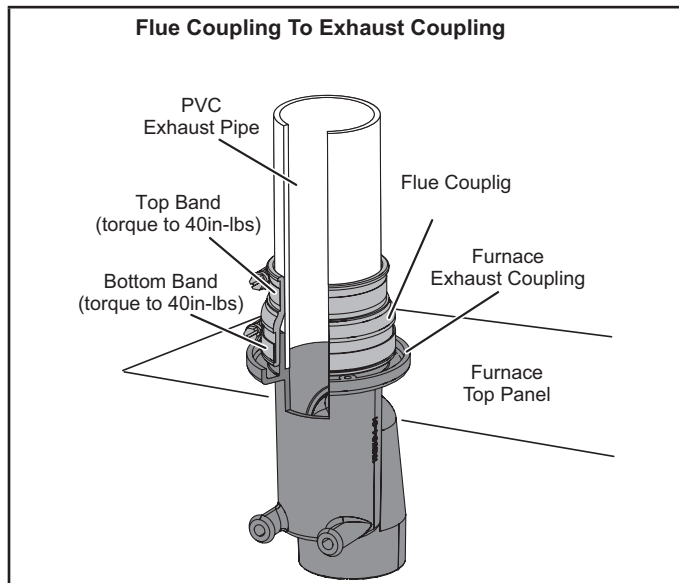

FIGURE 26

Crawl Space and Extended Horizontal Venting

Lennox provides kit 51W18(USA) and kit 15Z70 (Canada) to install 2" or 3" PVC exhaust piping through the floor joists and into the crawl space. This kit can also be used as a supplemental drain for installations with condensate run back in the vent pipe (ie. long horizontal runs, unconditioned spaces, etc.). See FIGURE 27 and FIGURE 28.

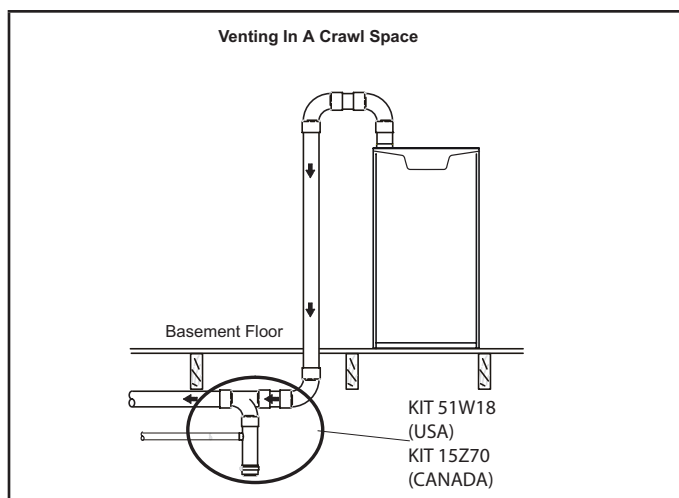

FIGURE 27

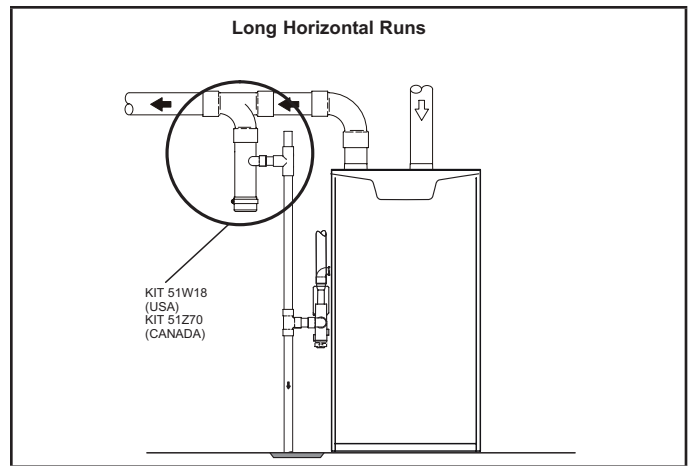

FIGURE 28

Guidelines for Vent Terminations

In Direct Vent applications, combustion air is taken from outdoors and the flue gases are discharged to the outdoors. The SLP99UHVK is classified as a direct vent, Category IV gas furnace.

In Direct Vent applications, the vent termination is limited by local building codes. In the absence of local codes, refer to the current National Fuel Gas Code ANSI Z223-1/ NFPA 54 in U.S.A., and current CSA-B149 Natural Gas and Propane Installation Codes in Canada for details.

Position termination according to location given in figure 20. In addition, position termination so it is free from any obstructions and 12" above the average snow accumulation.

At vent termination, care must be taken to maintain protective coatings over building materials (prolonged exposure to exhaust condensate can destroy protective coatings). It is recommended that the exhaust outlet not be located within 6 feet (1.8m) of an outdoor AC unit because the condensate can damage the painted coating.

NOTE - See TABLE 9 for maximum allowed exhaust pipe length without insulation in unconditioned space during-winter design temperatures below 32°F (0°C). If required exhaust pipe should be insulated with 1/2" (13mm) Armaflex or equivalent. In extreme cold climate areas, 3/4" (19mm) Armaflex or equivalent may be necessary. Insulation must be protected from deterioration. Armaflex with UV protection is permissible. Basements or other enclosed areas that are not exposed to the outdoor ambient temperature and are above 32 degrees F (0°C) are to be considered conditioned spaces.

! IMPORTANT

Do not use screens or perforated metal in exhaust or intake terminations. Doing so will cause freeze-ups and may block the terminations.

! IMPORTANT

For Canadian Installations Only:
In accordance to CSA International B149 installation codes, the minimum allowed distance between the combustion air intake inlet and the exhaust outlet of other appliances shall not be less than 12 inches (305mm).

TABLE 9

**Maximum Allowable Vent Pipe Length (in ft.³) Without Insulation In Unconditioned Space
For Winter Design Temperatures Modulating High Efficiency Furnace**

Winter Design Temperatures ¹ °F (°C)	Vent Pipe Diameter	Unit Input Size							
		070		090		110		135	
		PVC	² PP	PVC	² PP	PVC	² PP	PVC	² PP
32 to 21 (0 to -6)	1-1/2 in.	N/A	N/A	N/A	N/A	N/A	N/A	N/A	N/A
	2 in.	11	9	14	12	18	15		
	2-1/2 in.	7	N/A	10	N/A	12	N/A		
	3 in.	2	2	6	6	8	8	13	13
20 to 1 (-7 to -17)	1-1/2 in.	N/A	N/A	N/A	N/A	N/A	N/A	N/A	N/A
	2 in.	3	1	6	4	8	6		
	2-1/2 in.	1	N/A	1	N/A	3	N/A		
	3 in.	1	1	1	1	1	1	2	2
0 to -20 (-18 to -29)	1-1/2 in.	N/A	N/A	N/A	N/A	N/A	N/A	N/A	N/A
	2 in.	1	1	1	1	2	1		
	2-1/2 in.	1	N/A	1	N/A	1	N/A		
	3 in.	1	1	1	1	N/A			

¹Refer to 99% Minimum Design Temperature table provided in the current edition of the ASHRAE Fundamentals Handbook.

² PolyPro[®] poly-propylene vent pipe is a registered trademark of DuraVent[®]. InnoFlue[®] is a registered trademark of Centrotherm Eco Systems. ECCO Polypropylene Vent[™] is a registered trademark of ECCO Manufacturing[™].

³ Vent lengths in table are equivalent length. Consider each elbow as 5ft of linear length.

NOTE - Concentric terminations are the equivalent of 5' and should be considered when measuring pipe length.

NOTE - Maximum uninsulated vent lengths listed may include the termination (vent pipe exterior to the structure) and cannot exceed 5 linear feet or the maximum allowable intake or exhaust vent length listed in table 5 or which ever is less.

NOTE - If insulation is required in an unconditioned space, it must be located on the pipe closest to the furnace. See FIGURE 29.

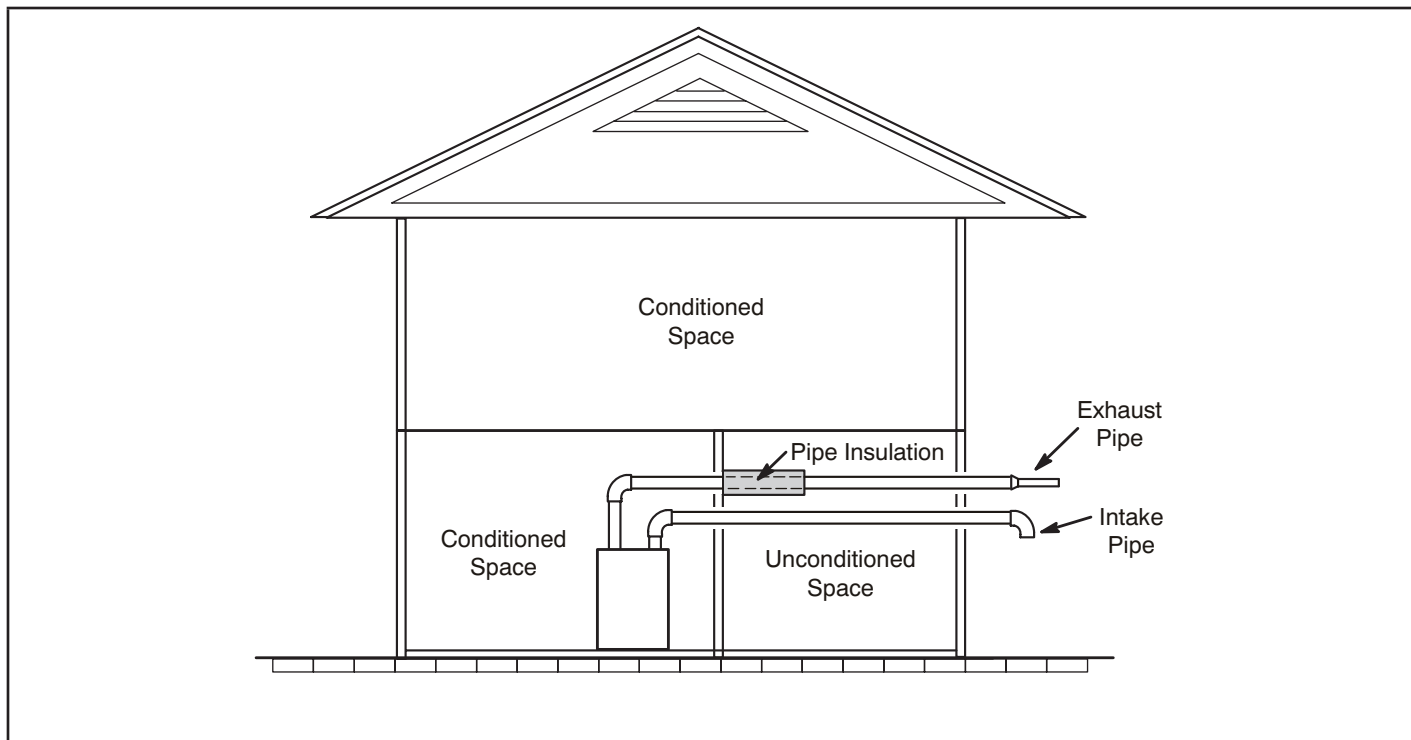

FIGURE 29

Details of Intake and Exhaust Piping Terminations for Direct Vent Installations

NOTE - In Direct Vent installations, combustion air is taken from outdoors and flue gases are discharged to outdoors.

NOTE - Flue gas may be slightly acidic and may adversely affect some building materials. If any vent termination is used and the flue gasses may impinge on the building material, a corrosion-resistant shield (minimum 24 inches square) should be used to protect the wall surface. If the optional tee is used, the protective shield is recommended. The shield should be constructed using wood, plastic, sheet metal or other suitable material. All seams, joints, cracks, etc. in the affected area should be sealed using an appropriate sealant. See FIGURE 37.

Intake and exhaust pipes may be routed either horizontally through an outside wall or vertically through the roof. In attic or closet installations, vertical termination through the roof is preferred. FIGURE 30 through FIGURE 38 shows typical terminations.

1 - Intake and exhaust terminations are not required to be in the same pressure zone. You may exit the intake on one side of the structure and the exhaust on another side (FIGURE 31). You may exit the exhaust out the roof and the intake out the side of the structure (FIGURE 32).

2 - Intake and exhaust pipes should be placed as close together as possible at termination end (refer to illustrations). Maximum separation is 3" (76mm) on roof terminations and 6" (152mm) on side wall terminations.

NOTE - When venting in different pressure zones, the maximum separation requirement of intake and exhaust pipe DOES NOT apply.

3 - On roof terminations, the intake piping should terminate straight down using two 90° elbows (FIGURE 30).

4 - Exhaust piping must terminate straight out or up as shown. A reducer may be required on the exhaust piping at the point where it exits the structure to improve the velocity of exhaust away from the intake piping. See TABLE 10.

NOTE - Care must be taken to avoid recirculation of exhaust back into intake pipe.

5 - On field-supplied terminations for side wall exit, exhaust piping may extend a maximum of 12 inches (305mm) for 2" PVC and 20 inches (508mm) for 3" (76mm) PVC beyond the outside wall. Intake piping should be as short as possible. See FIGURE 37 .

6 - On field-supplied terminations, a minimum distance between the end of the exhaust pipe and the end of the intake pipe without a termination elbow is 8" and a minimum distance of 6" with a termination elbow. See FIGURE 37.

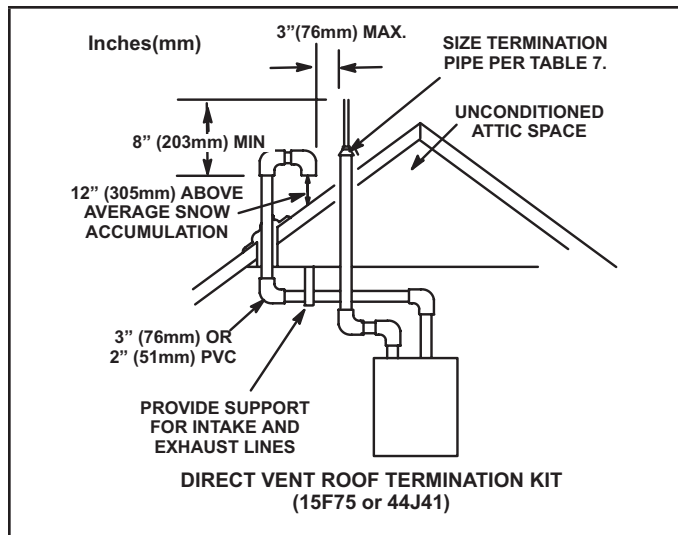

FIGURE 30

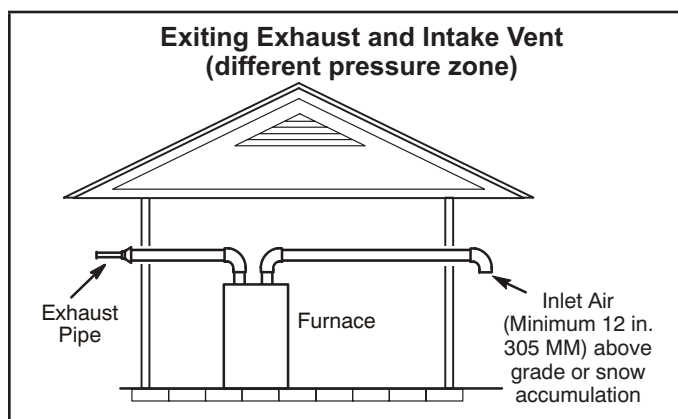

FIGURE 31

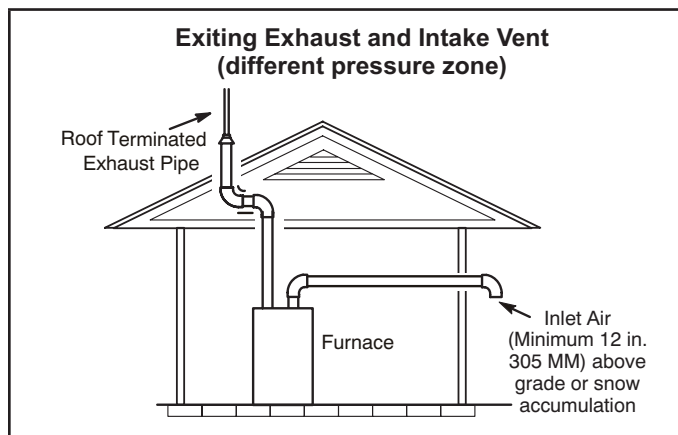

FIGURE 32

TABLE 10

EXHAUST PIPE TERMINATION SIZE REDUCTION	
SLP99UHVK Model	Termination Pipe Size
*070	1-1/2"
*090	2"
110	2"
135	2"

*-070 and -090 units with the flush-mount termination must use the 1-1/2" accelerator supplied with the kit.

- 7 - If intake and exhaust piping must be run up a side wall to position above snow accumulation or other obstructions, piping must be supported. At least one bracket must be used within 6" from the top of the elbow and then every 24" (610mm) as shown in FIGURE 37, to prevent any movement in any direction. When exhaust and intake piping must be run up an outside wall, the exhaust piping must be terminated with pipe sized per table 7. The intake piping may be equipped with a 90° elbow turndown. Using turndown will add 5 feet (1.5m) to the equivalent length of the pipe.
- 8 - Based on the recommendation of the manufacturer, a multiple furnace installation may use a group of up to four terminations assembled together horizontally, as shown in FIGURE 35.

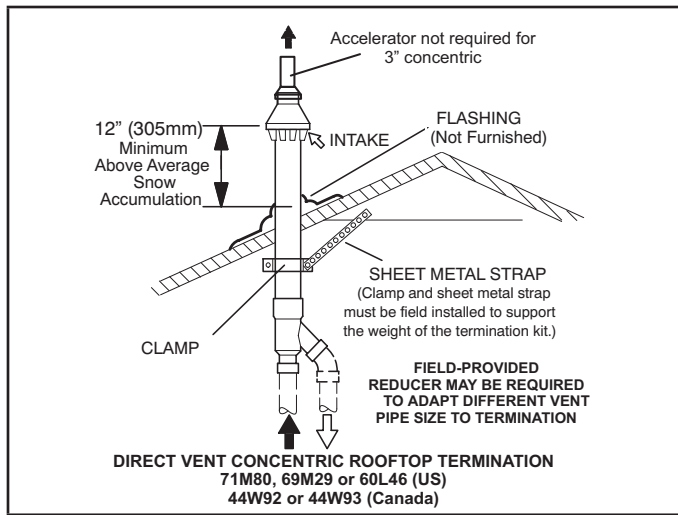

FIGURE 33

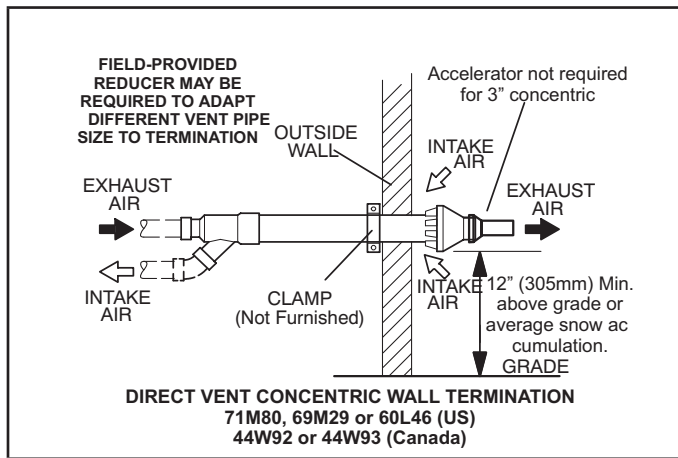

FIGURE 34

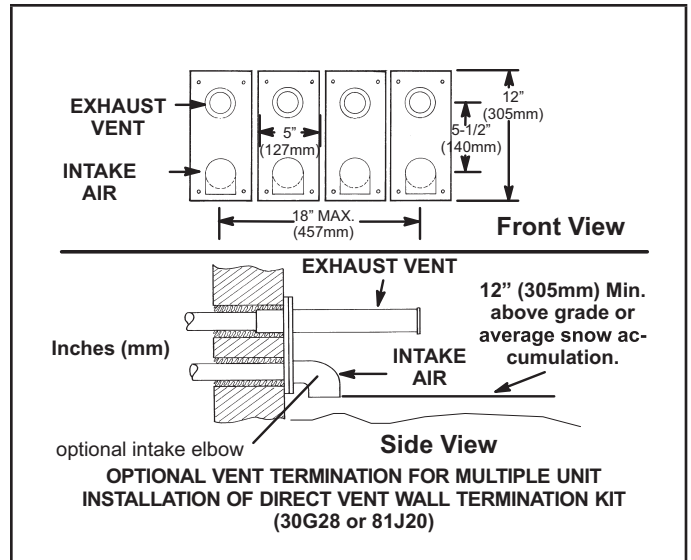

FIGURE 35

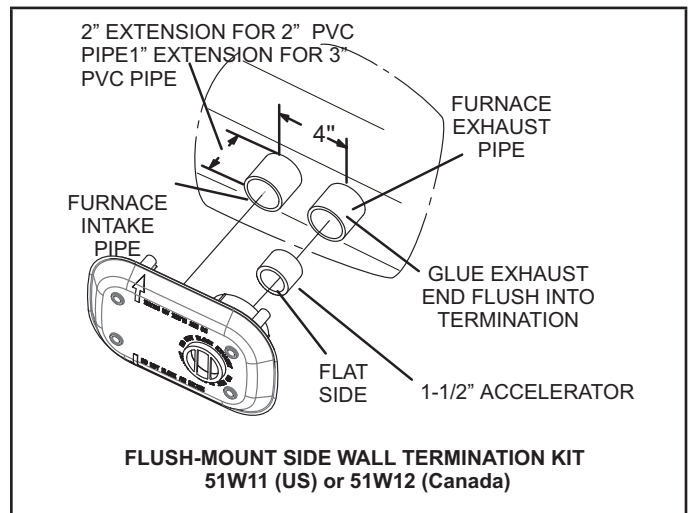
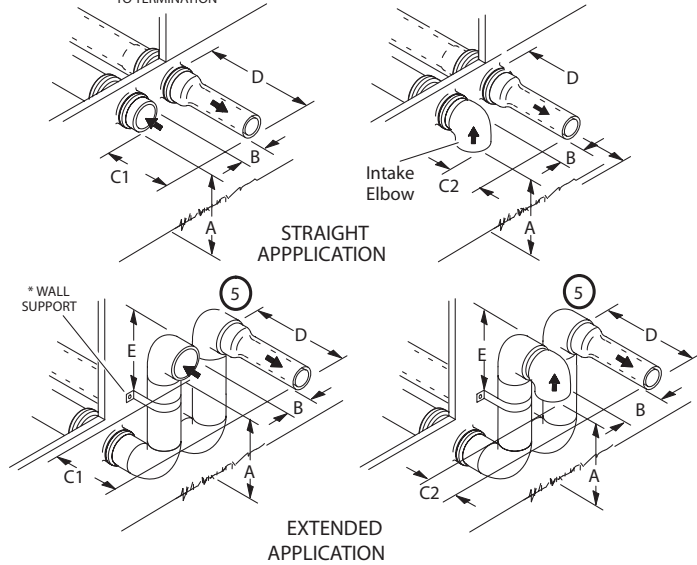

FIGURE 36

FIELD FABRICATED WALL TERMINATION

NOTE - FIELD -PROVIDED REDUCER MAY BE REQUIRED TO ADAPT LARGER VENT PIPE SIZE TO TERMINATION



	2" (51mm) Vent Pipe	3" (76mm) Vent Pipe
A - Minimum clearance above grade or average snow accumulation	12" (305 mm)	12" (305 mm)
B - Maximum horizontal separation between intake and exhaust	6" (152 mm)	6" (152 mm)
C1 -Minimum from end of exhaust to inlet of intake	8" (203 mm)	8" (203 mm)
C2 -Minimum from end of exhaust to inlet of intake	6" (152 mm)	6" (152 mm)
D - Maximum exhaust pipe length	12" (305 mm)	20" (508 mm)
E - Maximum wall support distance from top of each pipe (intake/exhaust)	6" (152 mm)	6" (152 mm)

See maximum allowable venting tables for venting lengths with this arrangement.

* Use wall support every 24" (610 mm). Use two wall supports if extension is greater than 24" (610 mm) but less than 48" (1219 mm).

NOTE - One wall support must be within 6" (152 mm) from top of each pipe (intake and exhaust) to prevent movement in any direction.

ALTERNATE TERMINATIONS (TEE & FORTYFIVE DEGREE ELBOWS ONLY)

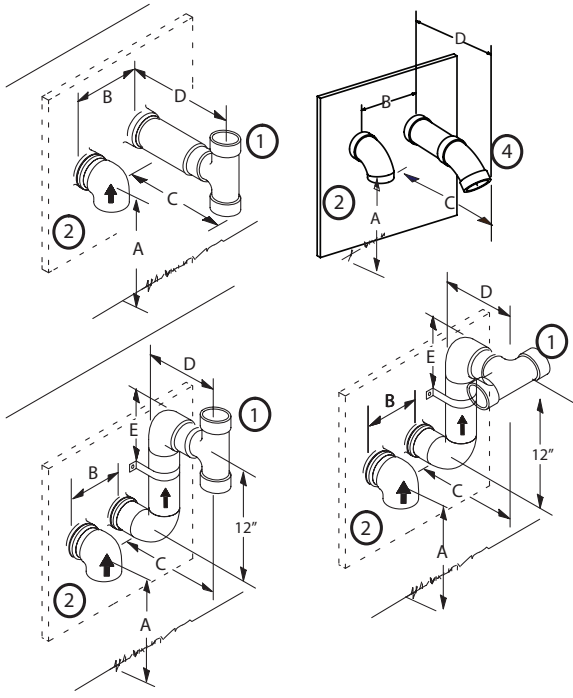

	2" (51mm) Vent Pipe	3" (76mm) Vent Pipe
A - Clearance above Grade or average snow accumulation	12" (305 mm) Min	12" (305 mm) Min
B - Horizontal separation between intake and exhaust	6" (152mm)min 24" (610mm)Max	6" (152mm)min 24" (610mm)Max
C - Minimum from end of exhaust to inlet of intake	9" (227mm)	9" (227mm)
D - Exhaust pipe length	12" (305mm)min 16" (405mm)Max	12" (305mm)min 16" (405mm)Max
E - Wall support distance from top of each pipe (intake/exhaust)	6" (152mm) Max	6" (152mm) Max

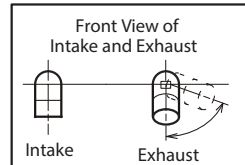

¹The exhaust termination tee should be connected to the 2" or 3" PVC flue pipe as shown in the illustration. In horizontal tee applications there must be a minimum of 3 ft away from covered patios or any living areas and cannot be within 3 ft of a window. Do not use an accelerator in applications that include an exhaust termination tee. The accelerator is not required.

² As required. Flue gas may be acidic and may adversely affect some building materials. If a side wall vent termination is used and flue gases will impinge on the building materials, a corrosion-resistant shield (24 inches square) should be used to protect the wall surface. If optional tee is used, the protective shield is recommended. The shield should be constructed using wood, sheet metal or other suitable material. All seams, joints, cracks, etc. in affected area, should be sealed using an appropriate sealant.

³ Exhaust pipe 45 ° elbow can be rotated to the side away from the combustion air inlet to direct exhaust away from adjacent property. The exhaust must never be directed toward the combustion air inlet.

⁴ Exhaust pipe can be rotated from the 12 o'clock position down to the 4 o'clock position

⁵ Exhaust pipe in double snorkel applications can use a 45 as an option to the accelerator tip.

FIGURE 37

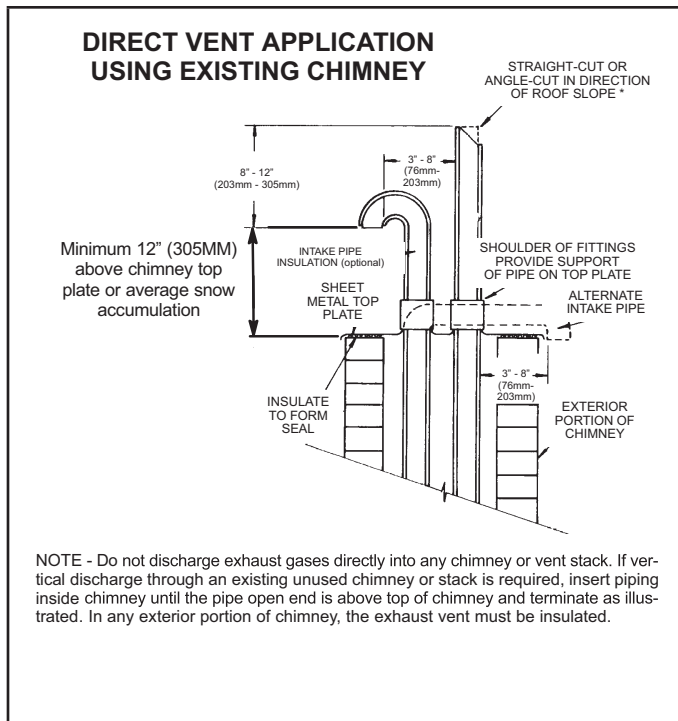

FIGURE 38

Condensate Piping

This unit is designed for either right- or left-side exit of condensate piping in upflow applications. In horizontal applications, the condensate trap must extend below the unit. An 8" service clearance is required for the condensate trap. Refer to FIGURE 39 and FIGURE 41 for condensate trap locations. FIGURE 47 shows trap assembly using 1/2" PVC or 3/4" PVC.

NOTE - If necessary the condensate trap may be installed up to 5' away from the furnace. Use PVC pipe to connect trap to furnace condensate outlet. Piping from furnace must slope down a minimum of 1/4" per ft. toward trap.

- 1 - Determine which side condensate piping will exit the unit, location of trap, field-provided fittings and length of PVC pipe required to reach available drain.
- 2 - Use a large flat head screw driver or a 1/2" drive socket extension and remove plug (figure 31) from the cold end header box at the appropriate location on the side of the unit. Install provided 3/4 NPT street elbow fitting into cold end header box. Use Teflon tape or appropriate pipe dope.

NOTE - Cold end header box drain plugs are factory installed. Check the unused plug for tightness to prevent leakage.

- 3 - Install the cap over the clean out opening at the base of the trap. Secure with clamp. See figure 39.
- 4 - Install drain trap using appropriate PVC fittings, glue all joints. Glue the provided drain trap as shown in FIGURE 47. Route the condensate line to an open drain. Condensate line must maintain a 1/4" downward slope from the furnace to the drain.

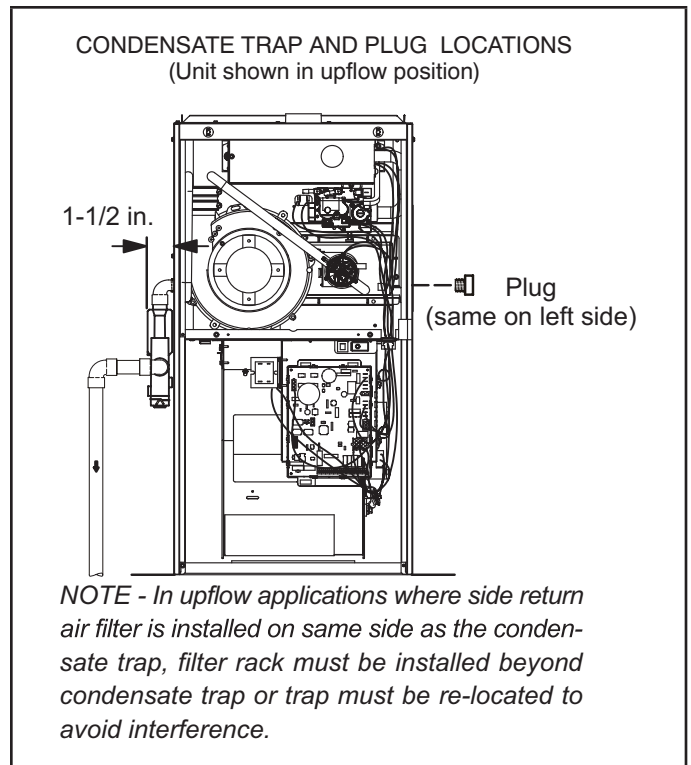

FIGURE 39

- 5 - FIGURE 42 and FIGURE 44 shows the furnace and evaporator coil using a separate drain. If necessary the condensate line from the furnace and evaporator coil can drain together. See FIGURE 43, FIGURE 45 and FIGURE 46. **Upflow furnace** (FIGURE 45) - In upflow furnace applications the field provided vent must be a minimum 1" to a maximum 2" length above the condensate drain outlet connection. Any length above 2" may result in a flooded heat exchanger if the combined primary drain line were to become restricted. **Horizontal furnace** (FIGURE 46) - In horizontal furnace applications the field provided vent must be a minimum 4" to a maximum 5" length above the condensate drain outlet connection. Any length above 5" may result in a flooded heat exchanger if the combined primary drain line were to become restricted.

NOTE - In horizontal applications it is recommended to install a secondary drain pan underneath the unit and trap assembly.

NOTE - Appropriately sized tubing and barbed fitting may be used for condensate drain. Attach to the drain on the trap using a hose clamp. See FIGURE 40.

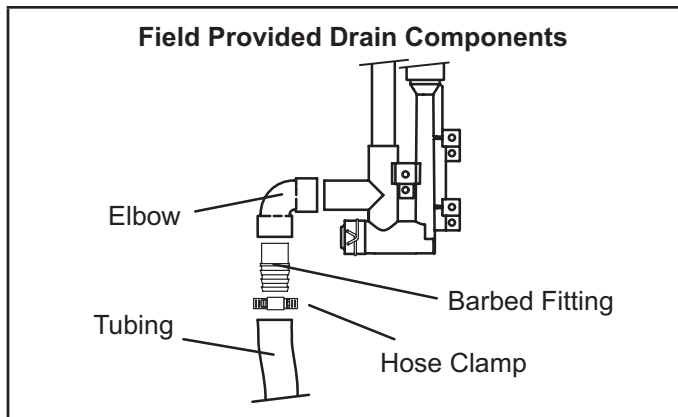

FIGURE 40

⚠ CAUTION

Do not use copper tubing or existing copper condensate lines for drain line..

- 6 - If unit will be started immediately upon completion of installation, prime trap per procedure outlined in Unit Start-Up section.

Condensate line must slope downward away from the trap to drain. If drain level is above condensate trap, condensate pump must be used. Condensate drain line should be routed within the conditioned space to avoid freezing of condensate and blockage of drain line. If this is not possible, a heat cable kit may be used on the condensate trap and line. Heating cable kit is available from Lennox in various lengths; 6 ft. (1.8m) - kit no. 26K68 and 24 ft. (7.3m) - kit no. 26K69.

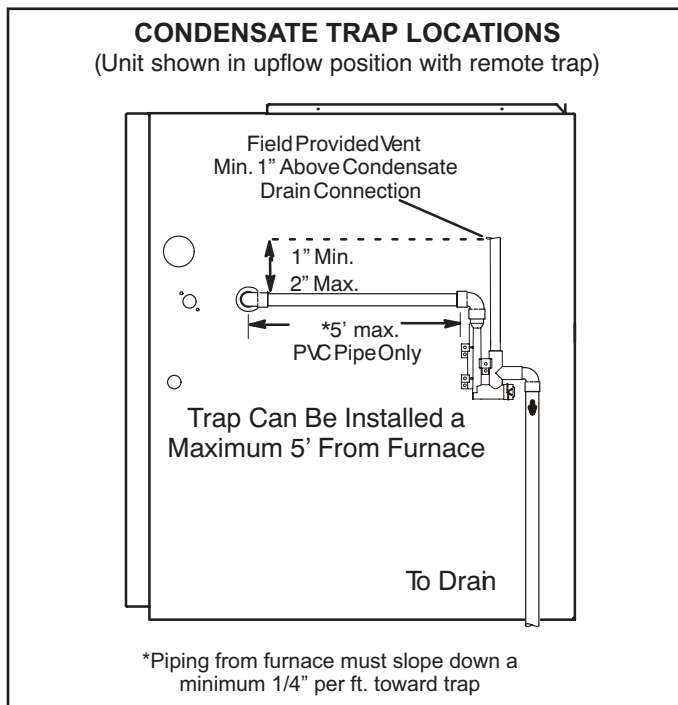

FIGURE 41

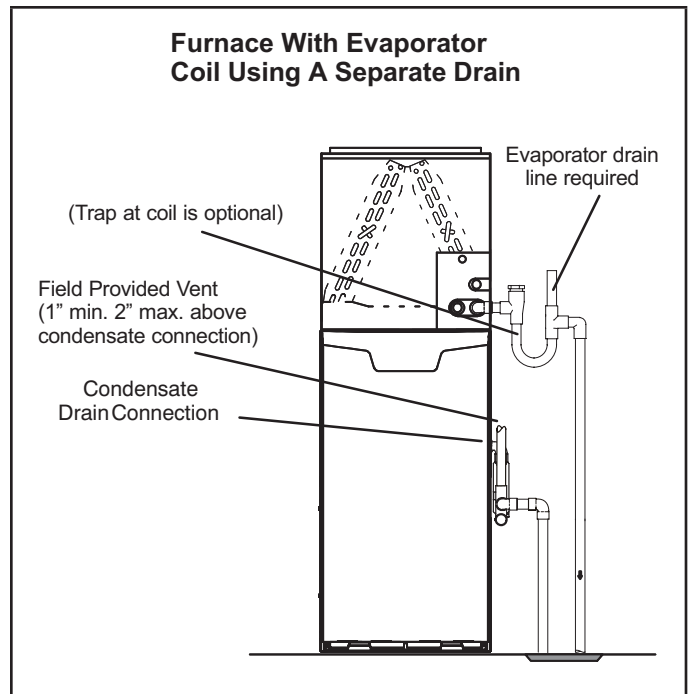

FIGURE 42

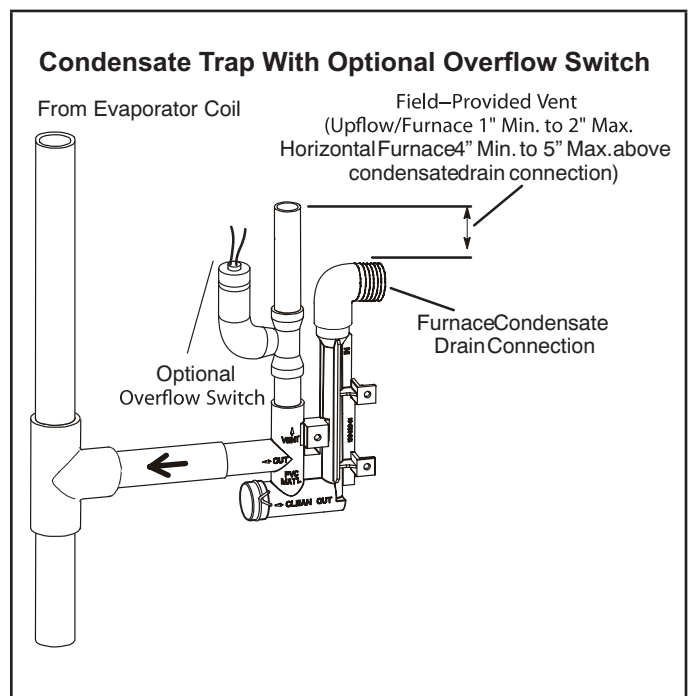

FIGURE 43

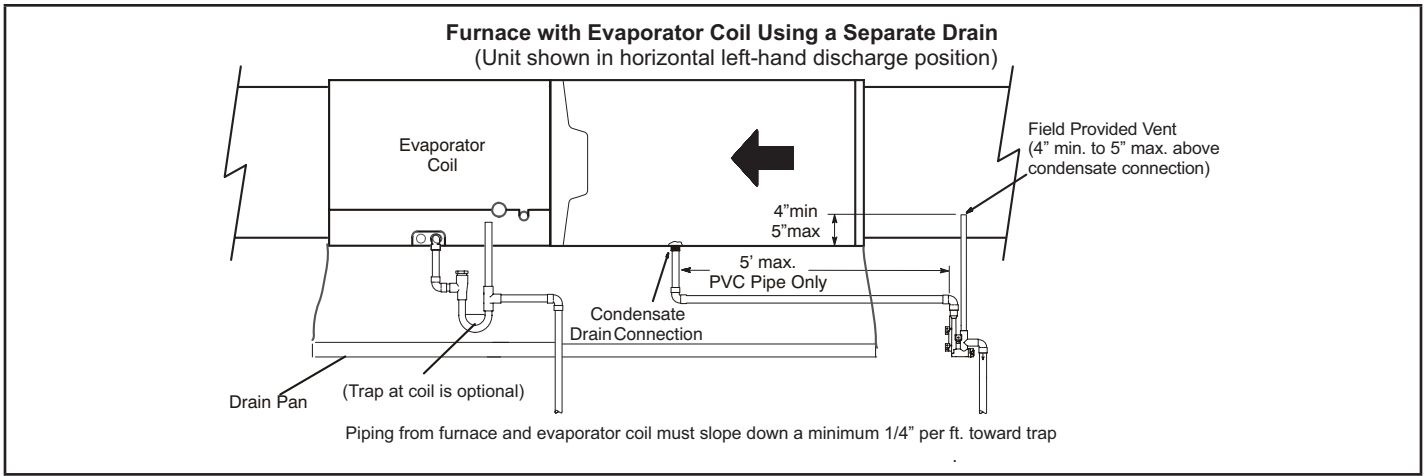

FIGURE 44

⚠ IMPORTANT

When combining the furnace and evaporator coil drains together, the A/C condensate drain outlet must be vented to relieve pressure in order for the furnace pressure switch to operate properly.

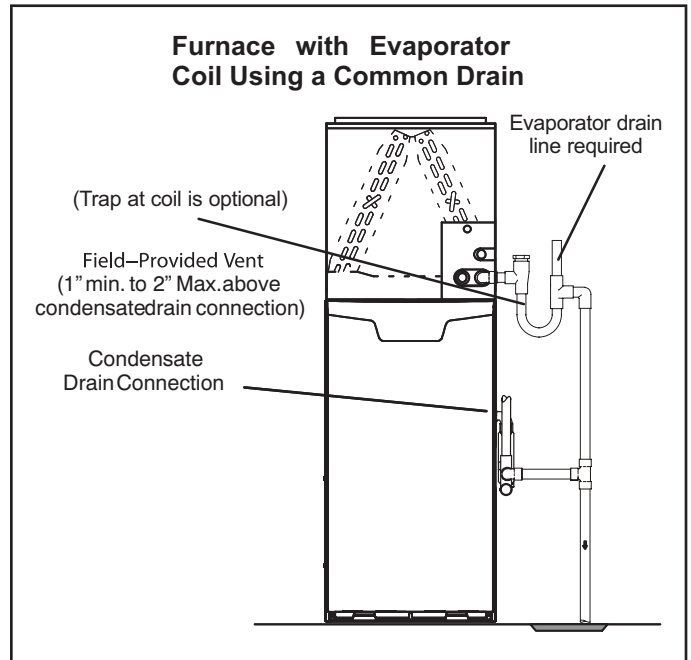

FIGURE 45

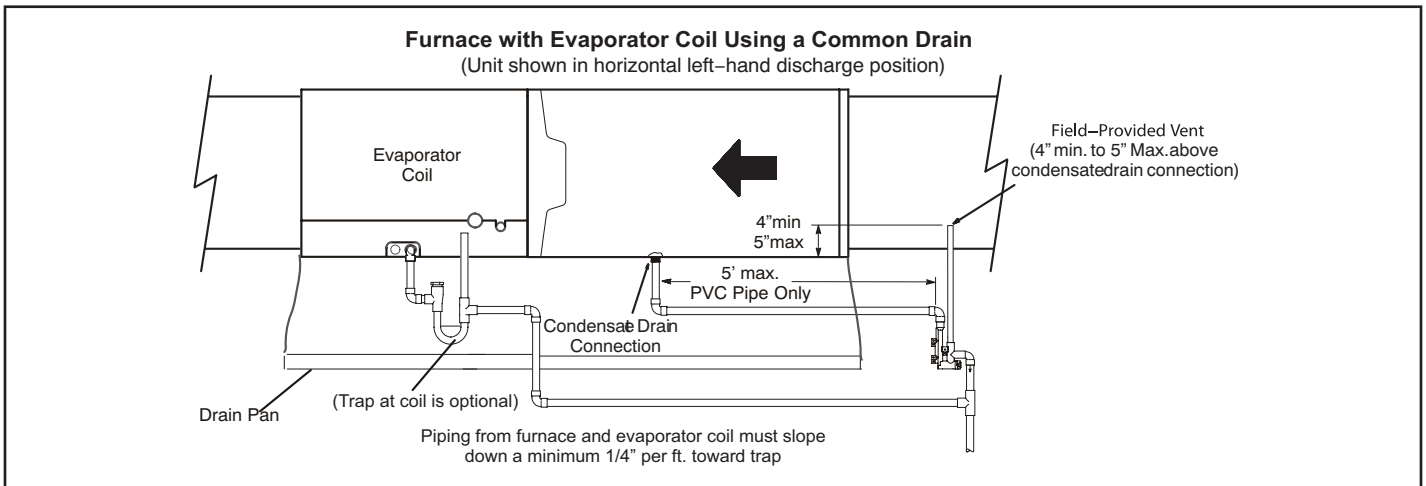
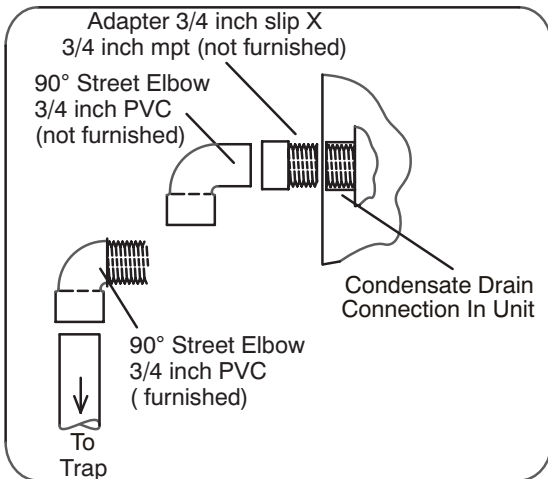

FIGURE 46

TRAP / DRAIN ASSEMBLY USING 1/2" PVC OR 3/4" PVC

Optional Condensate Drain Connection



Optional Drain Piping From Trap

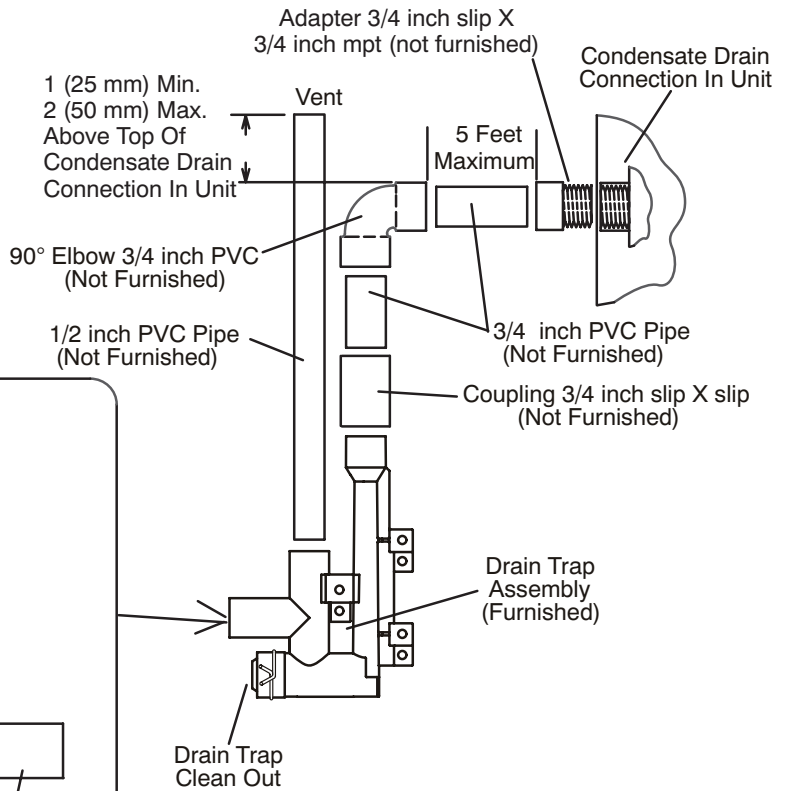
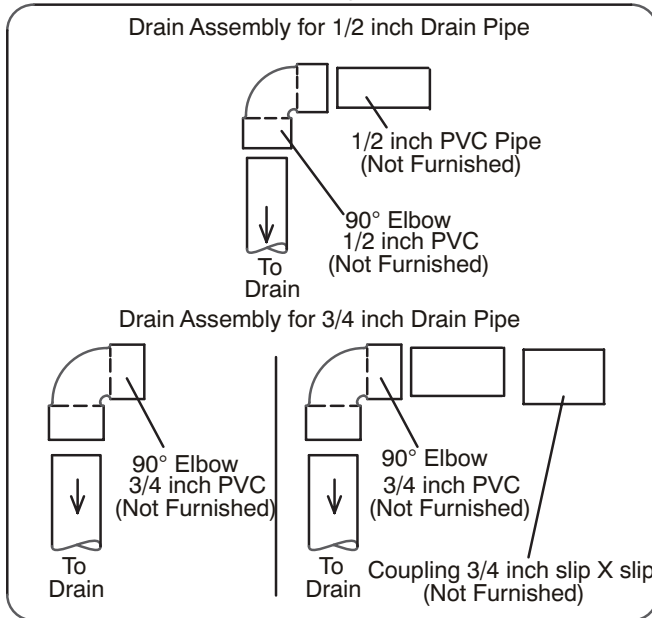

Drain Trap Assembly with 1/2 inch Piping

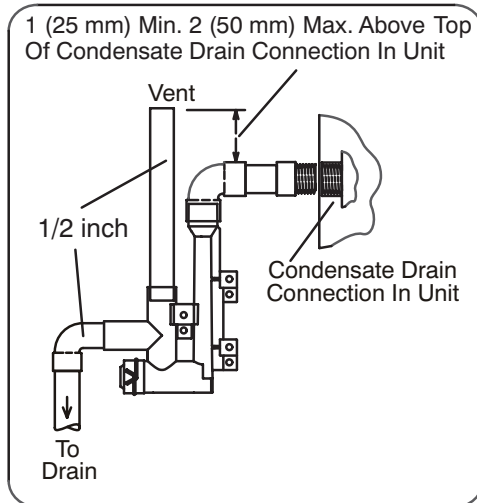

Drain Trap Assembly with 3/4 inch Piping

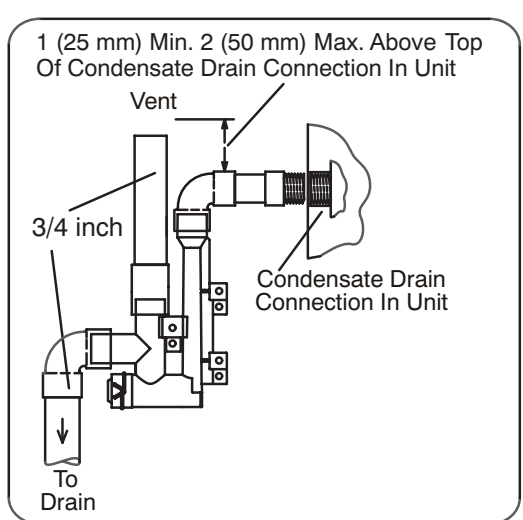

Drain Trap Assembly
(Furnished)

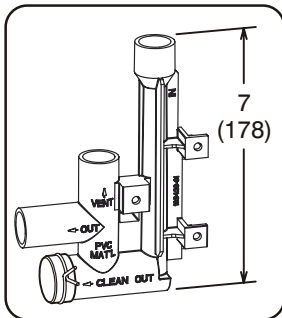

FIGURE 47

Gas Piping

⚠ CAUTION

If a flexible gas connector is required or allowed by the authority that has jurisdiction, black iron pipe shall be installed at the gas valve and extend outside the furnace cabinet. The flexible connector can then be added between the black iron pipe and the gas supply line.

⚠ WARNING

Do not over torque (800 in-lbs) or under torque (350 in-lbs) when attaching the gas piping to the gas valve.

- 1 - Gas piping may be routed into the unit through either the left- or right-hand side in upflow applications, and either the top or bottom in horizontal applications. Supply piping enters into the gas valve from the side of the valve as shown in FIGURE 49 and FIGURE 50. Connect the gas supply piping into the gas valve. The maximum torque is 800 in lbs and minimum torque is 350 in lbs when attaching the gas piping to the gas valve.

- 2 - When connecting gas supply, factors such as length of run, number of fittings and furnace rating must be considered to avoid excessive pressure drop. TABLE 11 lists recommended pipe sizes for typical applications.

NOTE - Use two wrenches when connecting gas piping to avoid transferring torque to the manifold.

- 3 - Gas piping must not run in or through air ducts, clothes chutes, chimneys or gas vents, dumb waiters or elevator shafts. Center gas line through piping hole. Gas line should not touch side of unit. See FIGURE 49 and FIGURE 50.
- 4 - Piping should be sloped 1/4 inch per 15 feet (6mm per 5.6m) upward toward the gas meter from the furnace. The piping must be supported at proper intervals, every 8 to 10 feet (2.44 to 3.05m), using suitable hangers or straps. Install a drip leg in vertical pipe runs to serve as a trap for sediment or condensate.
- 5 - A 1/8" N.P.T. plugged tap or pressure post is located on the gas valve to facilitate test gauge connection. See FIGURE 62.
- 6 - In some localities, codes may require installation of a manual main shut-off valve and union (furnished by installer) external to the unit. Union must be of the ground joint type.

⚠ IMPORTANT

Compounds used on threaded joints of gas piping must be resistant to the actions of liquified petroleum gases.

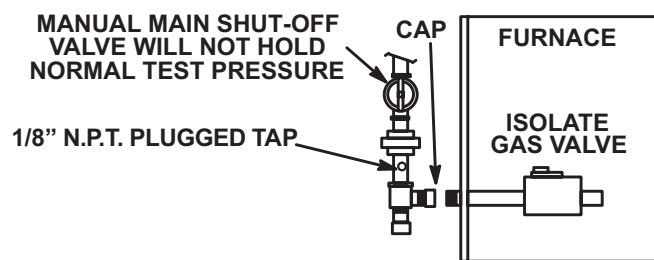

FIGURE 48

Leak Check

After gas piping is completed, carefully check all field-installed piping connections for gas leaks. Use a commercially available leak detecting solution specifically manufactured for leak detection. Never use an open flame to test for gas leaks.

The furnace must be isolated from the gas supply system by closing the individual manual shut-off valve during any gas supply system at pressures greater than or equal to 1/2 psig. (3.48 kPa, 14 inches w.c.). This furnace and its components are designed, manufactured and independently certified to comply with all applicable ANSI/CSA standards. A leak check of the furnace and its components is not required.

⚠ IMPORTANT

When testing gas lines using pressures in excess of 1/2 psig (3.48 kPa), gas valve must be disconnected and isolated. See FIGURE 48. Gas valves can be damaged if subjected to pressures greater than 1/2 psig (3.48 kPa)..

⚠ WARNING

FIRE OR EXPLOSION HAZARD..

Failure to follow the safety warnings exactly could result in serious injury, death, or property damage. Never use an open flame to test for gas leaks. Check all connections using a commercially available soap solution made specifically for leak detection. Some soaps used for leak detection are corrosive to certain metals. Carefully rinse piping thoroughly after leak test has been completed.

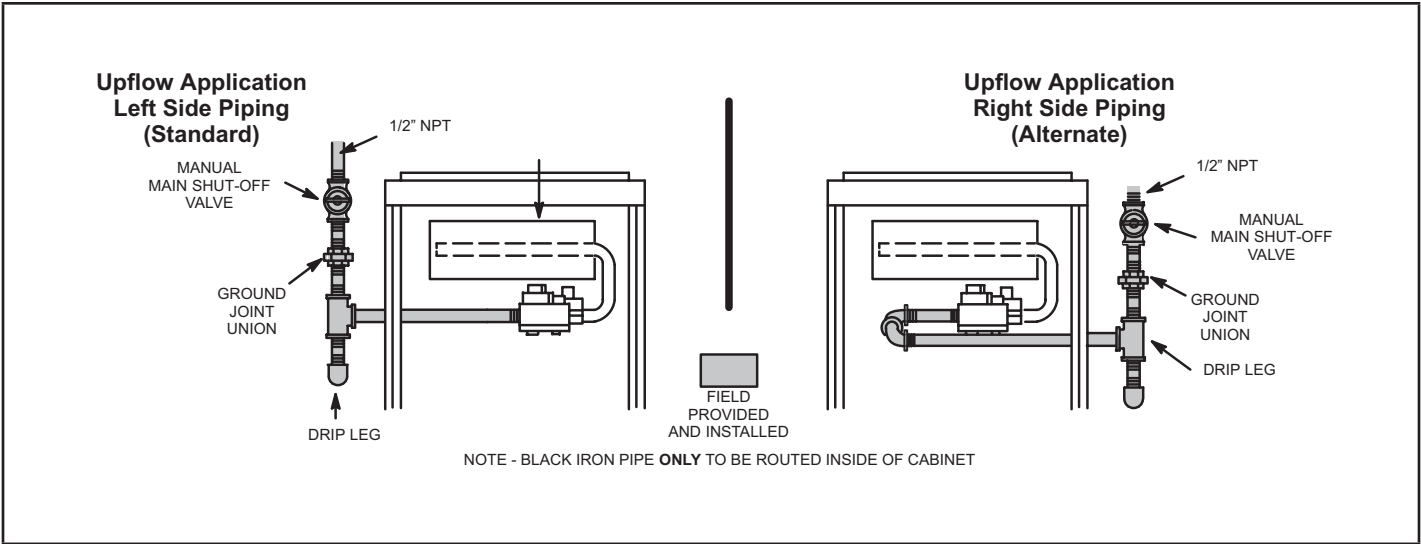

FIGURE 49

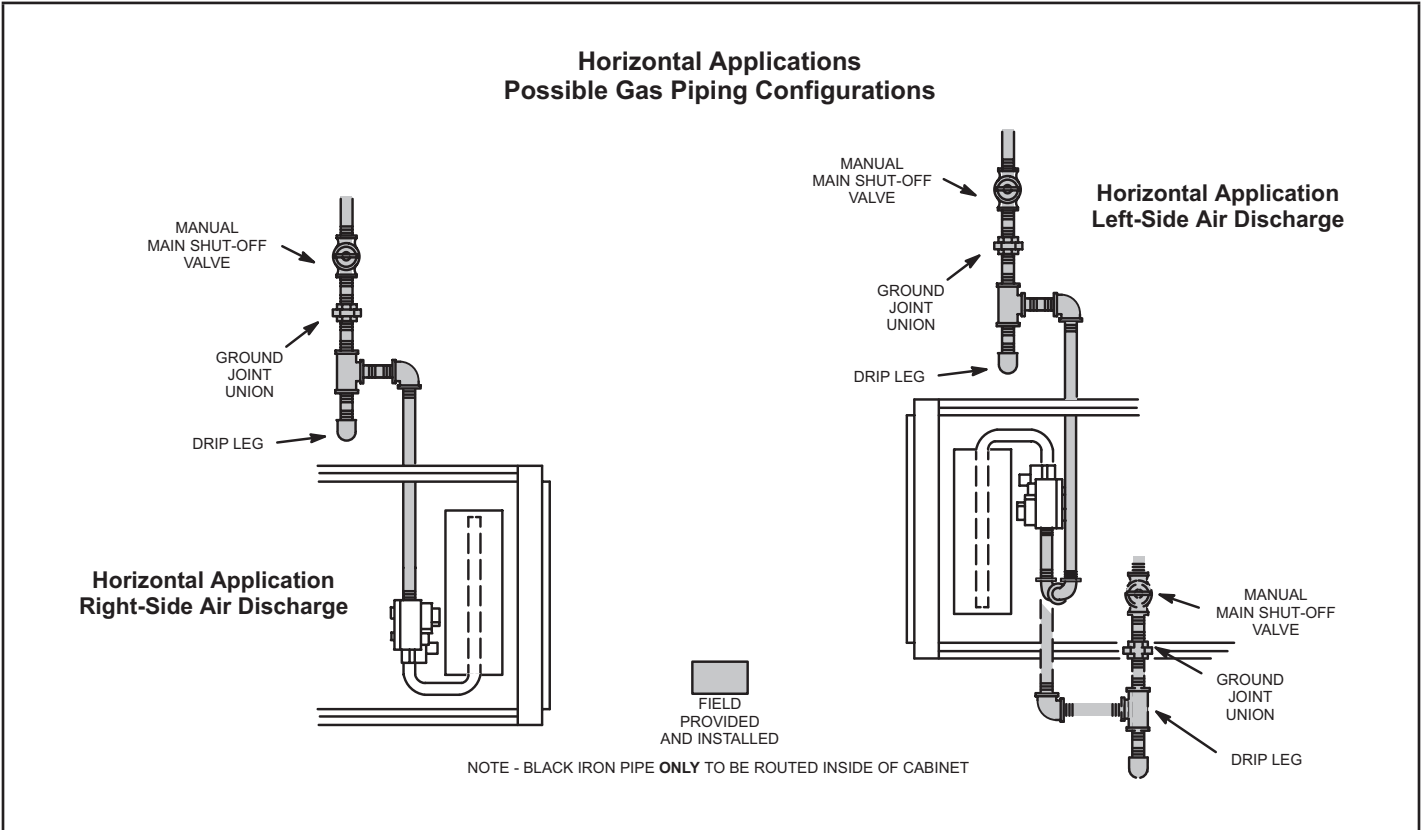

FIGURE 50

Removal of the Furnace from Common Vent

In the event that an existing furnace is removed from a venting system commonly run with separate gas appliances, the venting system is likely to be too large to properly vent the remaining attached appliances. Conduct the following test while each appliance is operating and the other appliances (which are not operating) remain connected to the common venting system. If the venting system has been installed improperly, you must correct the system as indicated in the general venting requirements section.

WARNING

CARBON MONOXIDE POISONING HAZARD

Failure to follow the steps outlined below for each appliance connected to the venting system being placed into operation could result in carbon monoxide poisoning or death. The following steps shall be followed for each appliance connected to the venting system being placed into operation, while all other appliances connected to the venting system are not in operation:

- 1 - Seal any unused openings in the common venting system.
- 2 - Inspect the venting system for proper size and horizontal pitch. Determine that there is no blockage, restriction, leakage, corrosion, or other deficiencies which could cause an unsafe condition.

- 3 - Close all building doors and windows and all doors between the space in which the appliances remaining connected to the common venting system are located and other spaces of the building. Turn on clothes dryers and any appliances not connected to the common venting system. Turn on any exhaust fans, such as range hoods and bathroom exhausts, so they will operate at maximum speed. Do not operate a summer exhaust fan. Close fireplace dampers.
- 4 - Follow the lighting instructions. Turn on the appliance that is being inspected. Adjust the thermostat so that the appliance operates continuously.
- 5 - After the main burner has operated for 5 minutes, test for leaks of flue gases at the draft hood relief opening. Use the flame of a match or candle.
- 6 - After determining that each appliance connected to the common venting system is venting properly, (step 3) return all doors, windows, exhaust fans, fireplace dampers, and any other gas-burning appliances to their previous mode of operation.
- 7 - If a venting problem is found during any of the preceding tests, the common venting system must be modified to correct the problem.

Resize the common venting system to the minimum vent pipe size determined by using the appropriate tables in Appendix G. (These are in the current standards of the National Fuel Gas Code ANSI Z223.1.

TABLE 11
Gas Pipe Capacity - ft³/hr (m³/hr)

Nominal Iron Pipe Size Inches (mm)	Internal Diameter inches (mm)	Length of Pipe - feet (m)									
		10 (3.048)	20 (6.096)	30 (9.144)	40 (12.192)	50 (15.240)	60 (18.288)	70 (21.336)	80 (24.384)	90 (27.432)	100 (30.480)
1/2 (12.7)	.622 (17.799)	172 (4.87)	118 (3.34)	95 (2.69)	81 (2.29)	72 (2.03)	65 (1.84)	60 (1.69)	56 (1.58)	52 (1.47)	50 (1.42)
3/4 (19.05)	.824 (20.930)	360 (10.19)	247 (7.000)	199 (5.63)	170 (4.81)	151 (4.23)	137 (3.87)	126 (3.56)	117 (3.31)	110 (3.11)	104 (2.94)
1 (25.4)	1.049 (26.645)	678 (19.19)	466 (13.19)	374 (10.59)	320 (9.06)	284 (8.04)	257 (7.27)	237 (6.71)	220 (6.23)	207 (5.86)	195 (5.52)
1-1/4 (31.75)	1.380 (35.052)	1350 (38.22)	957 (27.09)	768 (22.25)	657 (18.60)	583 (16.50)	528 (14.95)	486 (13.76)	452 (12.79)	424 (12.00)	400 (11.33)
1-1/2 (38.1)	1.610 (40.894)	2090 (59.18)	1430 (40.49)	1150 (32.56)	985 (27.89)	873 (24.72)	791 (22.39)	728 (20.61)	677 (19.17)	635 (17.98)	600 (17.00)
2 (50.8)	2.067 (52.502)	4020 (113.83)	2760 (78.15)	2220 (62.86)	1900 (53.80)	1680 (47.57)	1520 (43.04)	1400 (39.64)	1300 (36.81)	1220 (34.55)	1160 (32.844)
2-1/2 (63.5)	2.469 (67.713)	6400 (181.22)	4400 (124.59)	3530 (99.95)	3020 (85.51)	2680 (75.88)	2480 (70.22)	2230 (63.14)	2080 (58.89)	1950 (55.22)	1840 (52.10)
3 (76.2)	3.068 (77.927)	11300 (319.98)	7780 (220.30)	6250 (176.98)	5350 (151.49)	4740 (134.22)	4290 (121.47)	3950 (111.85)	3670 (103.92)	3450 (97.69)	3260 (92.31)

NOTE - Capacity given in cubic feet (m³) of gas per hour and based on 0.60 specific gravity gas.

Electrical

⚠ IMPORTANT

When matching this gas furnace with zoning, dual fuel or other 24V accessories, it is recommended to replace the factory installed transformer with kit 27J32.

Kit 27J32 contains a 75VA transformer, so you do not overload the original 40VA transformer.

ELECTROSTATIC DISCHARGE (ESD)

Precautions and Procedures

⚠ CAUTION

Electrostatic discharge can affect electronic components. Take precautions to neutralize electrostatic charge by touching your hand and tools to metal prior to handling the control.

⚠ WARNING



Electric Shock Hazard. Can cause electric shock. DO NOT touch blower drive until LEDs are off.

⚠ WARNING



Electric Shock Hazard. Can cause injury or death. Unit must be properly grounded in accordance with national and local codes.

⚠ WARNING

Fire Hazard. Use of aluminum wire with this product may result in a fire, causing property damage, severe injury or death. Use copper wire only with this product.

⚠ CAUTION

Failure to use properly sized wiring and circuit breaker may result in property damage. Size wiring and circuit breaker(s) per Product Specifications bulletin (EHB) and unit rating plate.

INTERIOR MAKE-UP BOX INSTALLATION

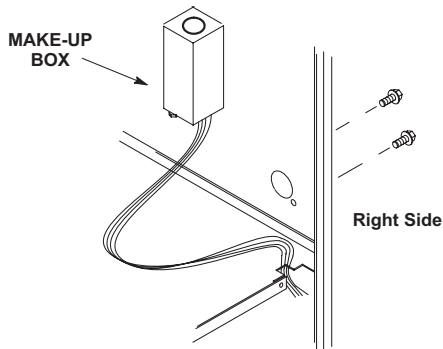

FIGURE 51

The unit is equipped with a field make-up box on the left hand side of the cabinet. The make-up box may be moved to the right side of the furnace to facilitate installation. If the make-up box is moved to the right side, clip the wire ties that bundle the wires together. The excess wire must be pulled into the blower compartment. Secure the excess wire to the existing harness to protect it from damage.

See FIGURE 52 and FIGURE 53 for thermostat wiring in communicating applications. TABLE 15 shows DIP switch and on-board link settings for non-communicating thermostat applications. Typical wiring schematic is shown in FIGURE 56 and FIGURE 57.

- 1 - The power supply wiring must meet Class I restrictions. Protected by either a fuse or circuit breaker, select circuit protection and wire size according to unit nameplate.

NOTE - Unit nameplate states maximum current draw. See TABLE 12 for maximum over-current protection.

TABLE 12

SLP99UHVK Model	Maximum Over-Current Protection Amps
070-36B, 090-36C, 090-48C	15
090-60C, 110-60C, 135-60D	20

- 2 - Holes are on both sides of the furnace cabinet to facilitate wiring.
- 3 - Install a separate (properly sized) disconnect switch near the furnace so that power can be turned off for servicing.
- 4 - Before connecting the thermostat or the power wiring, check to make sure the wires will be long enough for servicing at a later date. Remove the blower access panel to check the length of the wire.
- 5 - Complete the wiring connections to the equipment. Use the provided unit wiring and field wiring diagram shown in FIGURE 56 and FIGURE 57 and TABLE 15. Use 18-gauge wire or larger that is suitable for Class II rating for thermostat connections.

NOTE - Do NOT make a wire connection between the room thermostat L terminal and the L terminal of the SLP99UHVK integrated control unless this is a communicating thermostat installation with a non-communicating outdoor unit.

- 6 - Electrically ground the unit according to local codes or, in the absence of local codes, according to the current National Electric Code (ANSI/NFPA No. 70) for the USA and current Canadian Electric Code part 1 (CSA standard C22.1) for Canada. A green ground wire is provided in the field make-up box.
- 7 - One line voltage "EAC" 1/4" spade terminal is provided on the furnace integrated control. Any electronic air cleaner or other 120V accessory rated up to one amp can be connected to this terminal with the neutral leg.

of the circuit being connected to one of the provided neutral terminals. See FIGURE 58 for location of terminal. This terminal is energized when the indoor blower is operating.

- 8 - One line voltage "HUM" 1/4" spade terminal is provided on the furnace integrated control. Any humidifier or other 120V accessory rated up to one amp can be connected to this terminal with the neutral leg of the circuit being connected to one of the provided neutral terminals. See FIGURE 58 for location of terminal. This terminal is energized in the heating mode when the indoor blower is operating.
- 9 - One 24V "H" terminal is provided on the furnace integrated control terminal block. Any humidifier rated up to 0.5 amp can be connected to this terminal with the ground leg of the circuit being connected to either ground or the "C" terminal. See FIGURE 58 for location of terminal.
- 10 - 11 Install the room thermostat according to the instructions provided with the thermostat. See for thermostat connections. If the furnace is being matched with a heat pump, refer to the instruction packaged with the dual fuel thermostat.

NOTE - The discharge air temperature sensor is intended to be mounted downstream of the heat exchanger and air conditioning coil. It must be placed in free airflow, where other accessories (humidifiers, UV lights etc.) will not interfere with its accuracy. Wiring distance between the furnace and discharge air sensor should not exceed 10 ft. when wired with 18-gauge thermostat wire.

TABLE 13
Run Length - Non Communicating

Wire Run Length	AWG#	Insulation / Core Types
Less than 100' (30m)	18	Color-coded, temperature rating 95°F (35°C) minimum, solid core. (Class II 16 Rated Wiring)
More than 100' (30m)	16	

TABLE 14
Run Length - Non Communicating

Wire Run Length	AWG#	Insulation / Core Types
Maximum length of wiring for all connections on the RSBUS is limited to 1500 feet (457 meters).	18	Color-coded, temperature rating 95°F (35°C) minimum, solid core. (Class II 16 Rated Wiring)

Thermostat Selection

The SLP99UHVK is designed to operate in a variable rate capacity mode using a two-stage thermostat. The SLP99UHVK will automatically adjust firing rate based upon thermostat cycle times.

A communicating thermostat must be used in communicating applications. Refer to the instructions provided with the thermostat for installation, set-up and operation.

For optimal performance in non-communicating applications, Lennox recommends use of a ComfortSense® 7500 high quality electronic digital thermostat or any other with adjustable settings for 1st stage / 2nd stage on / off differentials and adjustable stage timers.

Lennox recommends the following two-stage thermostat set-up for optimal variable rate capacity mode: First heat stage differential set to 1/2 to 1 degree F; second heat stage differential set to 1/2 or 1 degree F; second heat stage upstage timer disabled, or set to maximum (1 hr minimum).

Indoor Blower Speeds

NOTE - When the SLP99UHVK is used with a communicating thermostat, proper indoor blower speed selections are made by the thermostat.

- 1 - When the thermostat is set to "FAN ON," the indoor blower will run continuously at a percentage of the second-stage cooling speed when there is no cooling or heating demand. The percentage is set using DIP switches 6 and 7. See TABLE 31 TABLE 31 on page 59 for allowable circulation speeds.
- 2 - When the SLP99UHVK is running in the heating mode, the integrated control will automatically adjust the blower speed to match the furnace firing rate. This speed can be adjusted up or down by 7.5% or 15% using DIP switches 14 through 16 for the low heat speed and 17 through 19 for the high heat speed. See TABLE 30 TABLE 30 on page 59 for allowable heating speeds.
- 3 - When there is a cooling demand, the indoor blower will run on the cooling speed designated by the positions of DIP switches 8 through 11.

Generator Use - Voltage Requirements

The following requirements must be kept in mind when specifying a generator for use with this equipment:

- The furnace requires 120 volts + 10% (Range: 108 volts to 132 volts).
- The furnace operates at 60 Hz + 5% (Range: 57 Hz to 63 Hz).
- The furnace integrated control requires both polarity and proper ground. Both polarity and proper grounding should be checked before attempting to operate the furnace on either permanent or temporary power.
- Generator should have a wave form distortion of less than 5% THD (total harmonic distortion).

Communicating Enabled Furnace with a Non-Communicating Outdoor Air Conditioning Unit

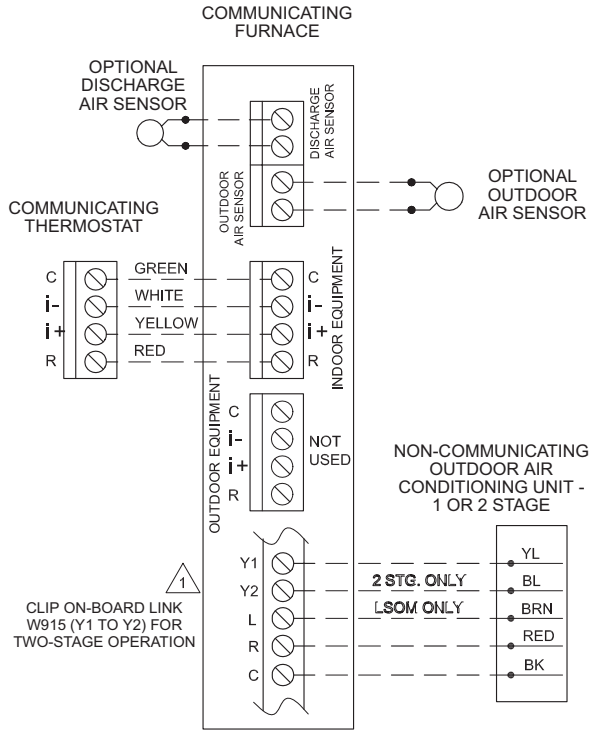

Communicating Enabled Furnace with a Communicating Enabled Outdoor Air Conditioning Unit

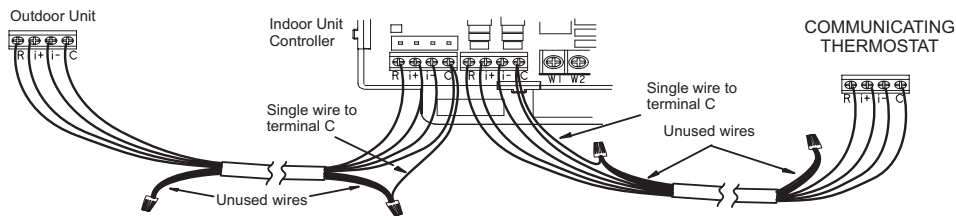
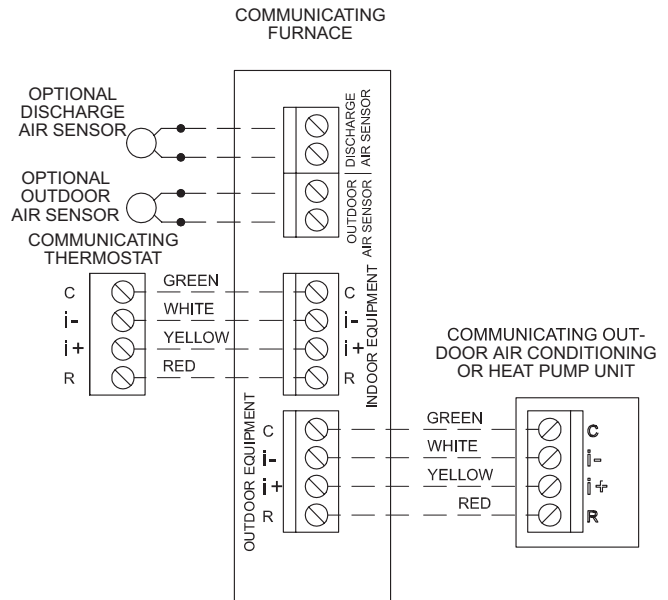

Communicating systems using the Communicating thermostat require four thermostat wires between the thermostat and the furnace/air handler control and four wires between the outdoor unit and the furnace/air handler control. When a thermostat cable with more than four wires is used, the extra wires must be properly connected to avoid electrical noise. The wires must not be left disconnected.

Use wire nuts to bundle the four unused wires at each end of the cable. A single wire should then be connected to the indoor unit end of the wire bundle and attached to the "C" terminals as shown above.

FIGURE 52

Communicating Enabled Furnace with a Non-Communicating Outdoor Heat Pump

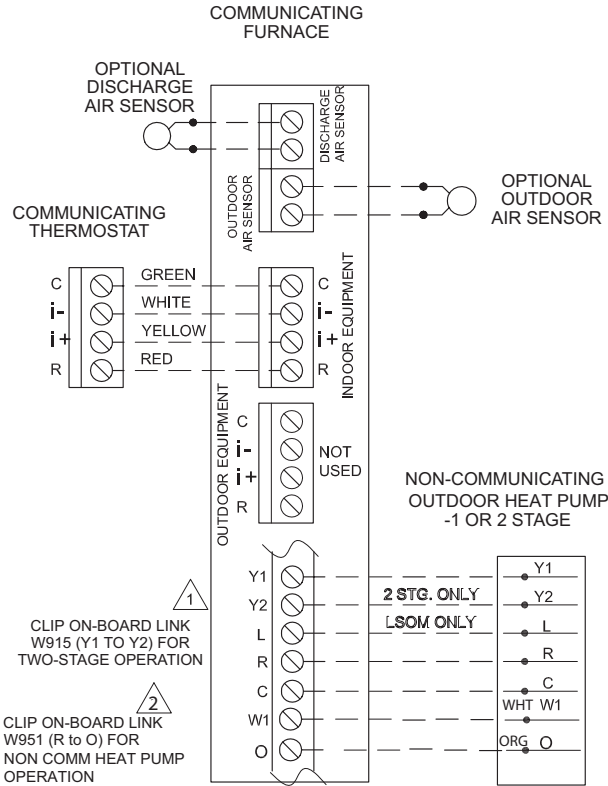

Communicating Enabled Furnace with a Communicating Enabled Outdoor Heat Pump

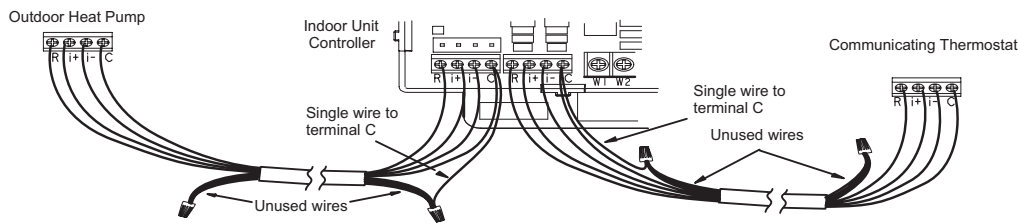
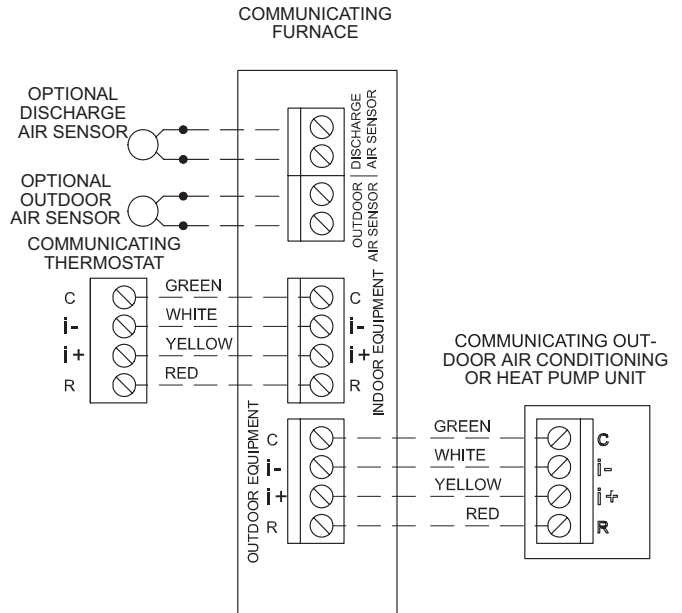

Communicating systems using the Communicating thermostat require four thermostat wires between the thermostat and the furnace/air handler control and four wires between the outdoor unit and the furnace/air handler control. When a thermostat cable with more than four wires is used, the extra wires must be properly connected to avoid electrical noise. The wires must not be left disconnected.

Use wire nuts to bundle the four unused wires at each end of the cable. A single wire should then be connected to the indoor unit end of the wire bundle and attached to the "C" terminals as shown above.

FIGURE 53

Communicating Wiring Optional Accessories

Optional Accessories for use with any Communicating System

NOTE: ICOMMUNICATING THERMOSTAT SENSES HUMIDITY & CONTROLS HUM CONTACTS TO CYCLE HUMIDIFIER BASED ON DEMAND. NO OTHER CONTROL OR HUMIDISTAT REQUIRED.
 OPTIONAL OUTDOOR AIR SENSOR FOR USE WITH HUMIDIFIER (IF NOT ALREADY IN THE SYSTEM FOR OTHER FUNCTIONS. BUILT INTO ALL COMMUNICATING ENABLED OUT DOOR UNITS).

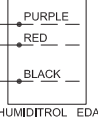
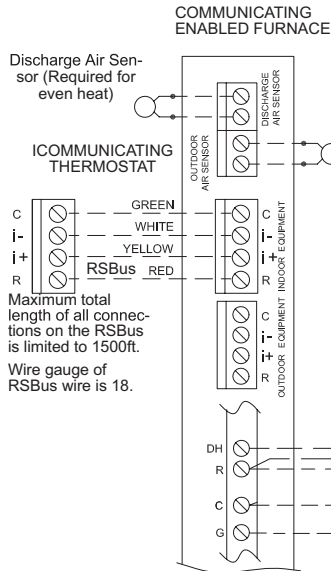
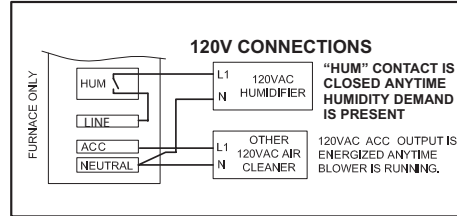

NOTE: 24V UV LIGHT APPLICATIONS

In a communicating system, neither furnace nor air handler transformer will have adequate VA to power 24V UV light applications. An additional transformer for UV light applications is required.

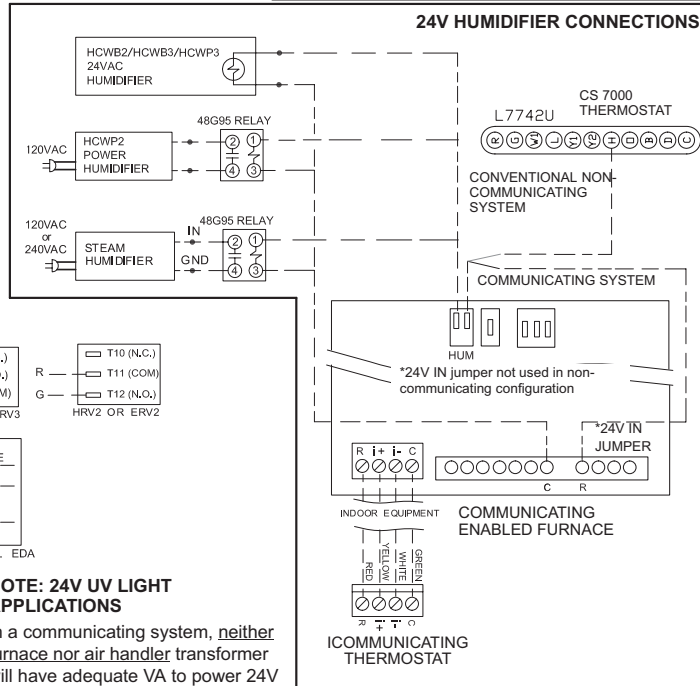

HEPA BYPASS FILTER X2680 HEPA INTERLOCK KIT

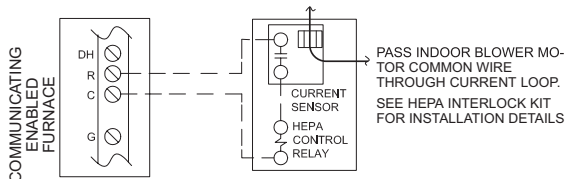

LVCS VENTILATION CONTROL SYSTEM

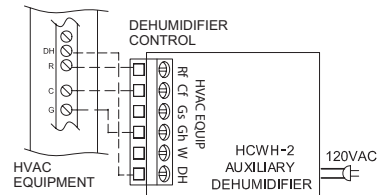
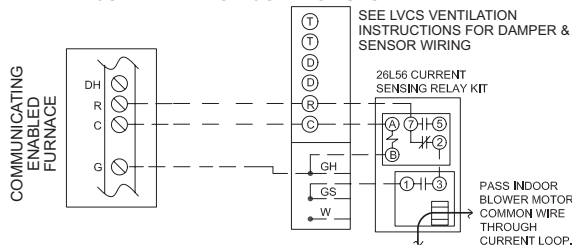
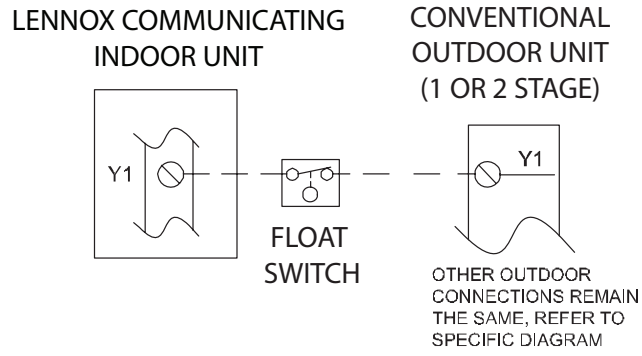

FIGURE 54



LENNOX COMMUNICATING FURNACE
EL297VK, SL280VK, SL280VNK, SL297VK, SLP99VK
cutting DS to R will not cause
communication interruption
or error code

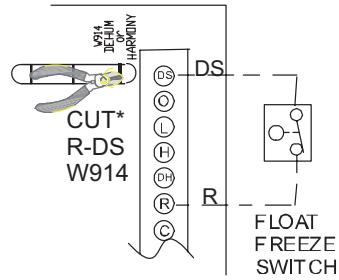

FIGURE 55

TABLE 15

Field Wiring Connections for Non-Communicating Thermostat Applications

Thermostat	DIP Switch Settings and On-Board Links / Jumper				Wiring Connections
	DIP Switch 1	Jumper (Y1 to Y2) Two-Stage Cooling	W914 (DS to R) Dehumidification or Harmony III™	W951 (O to R) Heat Pumps	
1Heat / 1 Cool <i>NOTE - Use DIP switch 3 to set second-stage heat ON delay. OFF-7 minutes. ON-12 minutes.</i>	ON	Intact	Intact	Intact	
1 Heat / 2 Cool <i>NOTE - Use DIP switch 3 to set second-stage heat ON delay. OFF-7 minutes. ON-12 minutes.</i>	ON	Cut	Intact	Intact	
1 Heat / 2 Cool with t'stat with dehumidification mode <i>NOTE - Use DIP switch 3 to set second-stage heat ON delay. OFF-7 minutes. ON-12 minutes.</i>	ON	Cut	Cut	Intact	

* "R" required on some units.

TABLE 15 Cont.

Field Wiring Connections for Non-Communicating Thermostat Applications (Continued)

Thermostat	DIP Switch Settings and On-Board Links / Jumper			Wiring Connections																															
	DIP Switch 1	Jumper (Y1 to Y2) Two-Stage Cooling	W914 (DS to R) Dehumidification or Harmony III™		W951 (O to R) Heat Pumps																														
2 Heat / 2 Cool	OFF	Cut	Intact	Intact	<table border="0"> <tr> <td>S1 T'STAT</td> <td>CONTROL TERM. STRIP</td> <td>OUTDOOR UNIT</td> </tr> <tr> <td></td> <td>(DS)</td> <td></td> </tr> <tr> <td>(W2)-----</td> <td>(W2)</td> <td></td> </tr> <tr> <td>(W1)-----</td> <td>(W1)</td> <td></td> </tr> <tr> <td>(R)-----</td> <td>(R)</td> <td>* (R)</td> </tr> <tr> <td>(G)-----</td> <td>(G)</td> <td></td> </tr> <tr> <td>(C)-----</td> <td>(C)</td> <td>(C)</td> </tr> <tr> <td>(Y2)-----</td> <td>(Y2)</td> <td>(Y2)</td> </tr> <tr> <td>(Y1)-----</td> <td>(Y1)</td> <td>(Y1)</td> </tr> <tr> <td></td> <td>(O)</td> <td></td> </tr> </table>	S1 T'STAT	CONTROL TERM. STRIP	OUTDOOR UNIT		(DS)		(W2)-----	(W2)		(W1)-----	(W1)		(R)-----	(R)	* (R)	(G)-----	(G)		(C)-----	(C)	(C)	(Y2)-----	(Y2)	(Y2)	(Y1)-----	(Y1)	(Y1)		(O)	
S1 T'STAT	CONTROL TERM. STRIP	OUTDOOR UNIT																																	
	(DS)																																		
(W2)-----	(W2)																																		
(W1)-----	(W1)																																		
(R)-----	(R)	* (R)																																	
(G)-----	(G)																																		
(C)-----	(C)	(C)																																	
(Y2)-----	(Y2)	(Y2)																																	
(Y1)-----	(Y1)	(Y1)																																	
	(O)																																		
2 Heat / 2 Cool with t'stat with dehumidification mode	OFF	Cut	Cut	Intact	<table border="0"> <tr> <td>S1 T'STAT</td> <td>CONTROL TERM. STRIP</td> <td>OUTDOOR UNIT</td> </tr> <tr> <td>(D)-----</td> <td>(DS)</td> <td></td> </tr> <tr> <td>(W2)-----</td> <td>(W2)</td> <td></td> </tr> <tr> <td>(W1)-----</td> <td>(W1)</td> <td></td> </tr> <tr> <td>(R)-----</td> <td>(R)</td> <td>* (R)</td> </tr> <tr> <td>(G)-----</td> <td>(G)</td> <td></td> </tr> <tr> <td>(C)-----</td> <td>(C)</td> <td>(C)</td> </tr> <tr> <td>(Y2)-----</td> <td>(Y2)</td> <td>(Y2)</td> </tr> <tr> <td>(Y1)-----</td> <td>(Y1)</td> <td>(Y1)</td> </tr> </table>	S1 T'STAT	CONTROL TERM. STRIP	OUTDOOR UNIT	(D)-----	(DS)		(W2)-----	(W2)		(W1)-----	(W1)		(R)-----	(R)	* (R)	(G)-----	(G)		(C)-----	(C)	(C)	(Y2)-----	(Y2)	(Y2)	(Y1)-----	(Y1)	(Y1)			
S1 T'STAT	CONTROL TERM. STRIP	OUTDOOR UNIT																																	
(D)-----	(DS)																																		
(W2)-----	(W2)																																		
(W1)-----	(W1)																																		
(R)-----	(R)	* (R)																																	
(G)-----	(G)																																		
(C)-----	(C)	(C)																																	
(Y2)-----	(Y2)	(Y2)																																	
(Y1)-----	(Y1)	(Y1)																																	
2 Heat / 1 Cool	OFF	Intact	Intact	Intact	<table border="0"> <tr> <td>S1 T'STAT</td> <td>CONTROL TERM. STRIP</td> <td>OUTDOOR UNIT</td> </tr> <tr> <td></td> <td>(DS)</td> <td></td> </tr> <tr> <td>(W2)-----</td> <td>(W2)</td> <td></td> </tr> <tr> <td>(W1)-----</td> <td>(W1)</td> <td></td> </tr> <tr> <td>(R)-----</td> <td>(R)</td> <td>* (R)</td> </tr> <tr> <td>(G)-----</td> <td>(G)</td> <td></td> </tr> <tr> <td>(C)-----</td> <td>(C)</td> <td>(C)</td> </tr> <tr> <td></td> <td>(Y2)</td> <td></td> </tr> <tr> <td>(Y)-----</td> <td>(Y1)</td> <td>(Y1)</td> </tr> <tr> <td></td> <td>(O)</td> <td></td> </tr> </table>	S1 T'STAT	CONTROL TERM. STRIP	OUTDOOR UNIT		(DS)		(W2)-----	(W2)		(W1)-----	(W1)		(R)-----	(R)	* (R)	(G)-----	(G)		(C)-----	(C)	(C)		(Y2)		(Y)-----	(Y1)	(Y1)		(O)	
S1 T'STAT	CONTROL TERM. STRIP	OUTDOOR UNIT																																	
	(DS)																																		
(W2)-----	(W2)																																		
(W1)-----	(W1)																																		
(R)-----	(R)	* (R)																																	
(G)-----	(G)																																		
(C)-----	(C)	(C)																																	
	(Y2)																																		
(Y)-----	(Y1)	(Y1)																																	
	(O)																																		

* "R" required on some units.

TABLE 15 Cont.

Field Wiring Connections for Non-Communicating Thermostat Applications (Contiued)

Thermostat	DIP Switch Settings and On-Board Links / Jumper				Wiring Connections
	DIP Switch	Jumper (Y1 to Y2) Two-Stage Cooling	W914 (DS to R) Dehumidification or Harmony III™	W951 (O to R) Heat Pumps	
Dual Fuel Single-Stage Heat Pump ComfortSense® 7000 L7742U thermostat w/ dual fuel capabilities Capable of 2-stage gas heat control	DIP Switch 1 OFF	Intact	Intact	Cut	
Dual Fuel Two Stage Heat Pump ComfortSense® 7000 L7742U thermostat w/ dual fuel capabilities Capable of 2-stage gas heat control	DIP Switch 1 OFF	Cut	Intact	Cut	

* Connect W1 to W1 ONLY if using defrost tempering kit 67M41.

NOTE - Do NOT make a wire connection between the room thermostat L terminal and the L terminal of the integrated control.

**Modulating, Variable Speed and Communicating
107901-01**

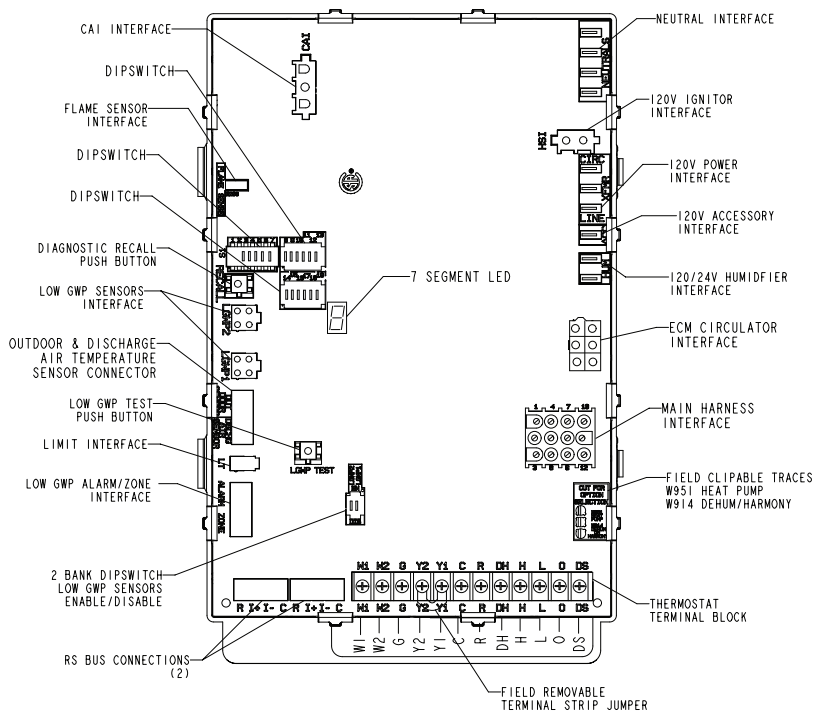

FIGURE 58

TABLE 16

THERMOSTAT INPUT TERMINALS	
W1	LOW STAGE HEAT
W2	HIGH STAGE HEAT
G	FAN
Y1	LOW STAGE COOL
Y2	HIGH STAGE COOL24
C	THERMOSTAT COMMON / GROUND
R	24VAC POWER TO THE THERMOSTAT
DH	DEHUMIDIFICATION (COMM ONLY)
H	24V HUMIDIFIER OUTPUT
L	LSOM (COMM ONLY)
O	HEAT PUMP REVERSING VALVE
DS	DEHUMIDIFICATION (NON-COMM ONLY)

TABLE 17

LOW GWP INTERFACE	
LGWP1	LOW GWP SENSOR #1 INTERFACE
LGWP2	LOW GWP SENSOR # 2 INTERFACE
ALARM	INTERFACE TO LOW GWP LEAK AUDIBLE ALARM (DRY CONTACT)
ZONE	INTERFACE TO ZONING CONTROL FOR LOW GWP APPLICATIONS
LGWP TEST	PUSH BUTTONT TO TEST LOW GWP FUNCTIONALITY

TABLE 18

1/4" QUICK CONNECT TERMINALS	
HUM	120 VAC OUTPUT TO HUMIDIFIER
XMFR	120 VAC OUTPUT TO TRANSFORMER
L1	120 VAC INPUT TO CONTROL
CIRC	120 VAC OUTPUT TO CIRCULATING BLOWER
EAC	120 VAC TO ELECTRICAL AIR CLEANER
NEUTRALS	120 VAC NEUTRAL

RS - BUS OUTDOOR	
R	24VAC
1+	DATA HIGH CONNECTION
1-	DATA LOW CONNECTION
C	24VAXC COMMON
RS - BUS INDOOR	
R	24VAC
1+	DATA HIGH CONNECTION
1-	DATA LOW CONNECTION
C	24VAXC COMMON

LED Segment Status / Error Code

Press the diagnostic push button and hold it to cycle through a menu of options. Every five seconds a new menu item will be displayed.

Release the button when the desired mode is displayed.

When a solid "P" is displayed, the furnace capacity/ size is programmed.

When the solid "E" is displayed, the control enters the Error Code Recall mode. Error Code Recall mode menu options: No change (displaying error history) remains in Error Code Recall mode; solid "b" exits Error Code Recall mode; and solid "c" clears the error history. Must press button while flashing "c" is displayed to clear error codes.

When the solid "-" is displayed, the control enters the Field Test mode. Field Test mode menu options: Solid "C" starts pressure switch calibration; blinking "-" exits Field Test mode.

Code	Diagnostic Codes/Status of Equipment	Action Required to Clear and Recover
.	Idle mode (Decimal blinks at 1 Hertz -- 0.5 second ON, 0.5 second OFF).	
A	Cubic feet per minute (cfm) setting for indoor blower (1 second ON, 0.5 second OFF) / cfm setting for current mode displayed.	
C	Cooling stage (1 second ON, 0.5 second OFF) / 1 or 2 displayed / Pause / cfm setting displayed / Pause / Repeat codes).	
d	Dehumidification mode (1 second ON 1 second OFF) cfm setting displayed /Pause / Repeat Codes.	
h	Variable Capacity Heat (1 second ON, 0.5 second OFF) / % of input rate displayed / Pause/ cfm setting / Pause/ Repeat codes.	
H	Heat Stage (1 second ON, 0.5 second OFF) / 1 or 2 displayed / Pause / cfm setting displayed / Pause / Repeat codes.	
df	Defrost mode.	
U	Discharge air temperature	
-	Soft disable - Soft disabling is when thermostat finds a device on the BUS that it does not recognize and the thermostat sends a the device a message to be in soft disabling mode until properly configured. Two horizontal bars will display.	<p>Steps to follow if the damper control module is displaying the soft disable code.</p> <p>Confirm proper wiring between all devices (thermostat, damper control module, indoor and outdoor).</p> <p>Cycle power to the control that is displaying the soft disable code.</p> <p>Put the room thermostat through set up.</p> <p>Go to setup / system devices / thermostat / edit / then push reset.</p> <p>Go to setup / system devices / thermostat / edit / then push resetAll.</p>

Integrated Control Diagnostic Codes

Code	Diagnostic Codes/Status of Equipment	Action Required to Clear and Recover
E105	Device communication problem - No other devices on BUS (Communication system).	Equipment is unable to communicate. Check for mis wire and loose connections and check for a high voltage source of noise close to the system. (welder etc.).
E110	Low line voltage.	Line Voltage low (Voltage lower than nameplate rating) Check voltage.
E111	Line voltage polarity reversed	Reverse line voltage wiring. System resumes normal operation 5 seconds after fault recovered.
E112	Earth ground not detected	System shuts down. Provide proper earth ground. System resumes normal operation 5 seconds after fault recovered
E113	High line voltage.	Line Voltage High (Voltage higher than nameplate rating) Check voltage.
E114	Line voltage frequency out-of-range.	No 60 hertz power (Check voltage and frequency).
E115	Low 24V - Control will restart if the error recovers.	24 voltage low (Range is 18 to 30 volts) Check voltage.
E117	Poor ground detected (Warning only)	Provide proper grounding for unit. Check for proper earth ground to the system. Warning only will clear 30 seconds after fault recovered.
E118	Reset limit exceeded (Hard-Lockout)	The unit entered and manually exited a soft lockout state six times within a 15-minute interval. Perform a power cycle to clear the fault condition and restore normal operation.
E120	Unresponsive device.	Usually caused by delay in outdoor unit responding to indoor unit poling recycle power, check wiring.
E124	Active communicating thermostat signal missing for more than 3 minutes.	Equipment lost communication with the thermostat. Check connections and cycle power on the thermostat.
E125	Control failed self-check, internal error, failed hardware. Will restart if error recovers. Integrated furnace control not communicating. Covers hardware errors (flame sense circuit faults, pin shorts, etc.).	Hardware problem on the control board. Cycle power on control. Replace if problem prevents service and is persistent.
E126	Failed internal control communication between microcontrollers.	Hardware problem on the control board. Cycle power on control. Replace if problem prevents service and is persistent.
E180	Outdoor air sensor failure - NO error if disconnected. Only shown if shorted or out-of-range.	
E200	Hard lockout - Rollout circuit open or previously open.	Correct unit cause of rollout trip or replace flame rollout switch and test furnace operation.
E201	Indoor blower communication failure - Unable to communicate with blower motor.	Indoor blower communication failure including power outage.
E202	Indoor blower motor mis-match - Indoor motor horsepower does not match unit capacity.	Incorrect furnace size code selected. Check unit size codes on configuration guide or in installation instructions.

Integrated Control Diagnostic Codes (Continued)

Code	Diagnostic Codes/Status of Equipment	Action Required to Clear and Recover
E203	Appliance capacity / size is NOT programmed. Invalid unit codes refer to configuration flow chart in installation instructions.	No furnace size code selected. Check unit size codes on configuration guide or in installation instructions.
E204	Gas valve mis-wired.	Check operation of gas valve.
E205	Gas valve control relay contact shorted.	Check operation of gas valve.
E207	Hot surface ignitor sensed open - Refer to troubleshooting in installation instruction.	Measure resistance of Hot Surface Ignitor, replace if open or not within specification.
E223	Low pressure switch failed open - Refer to troubleshooting in installation instruction.	Check inches of water column pressure during operation of low pressure switch on heat call, measure inches of water column of operating pressure, inspect vent and combustion air inducer for correct operation and restriction.
E224	Low pressure switch failed closed - Refer to troubleshooting in installation instruction.	Check low pressure switch for closed contacts, measure inches of water column of operating pressure, inspect vent and combustion air inducer for correct operation and restriction.
E225	High pressure switch failed open - Refer to troubleshooting in installation instruction.	Check inches of water column pressure of high pressure switch on heat call, measure inches of water column of operating pressure, inspect vent and combustion air inducer for correct operation and restriction.
E226	High pressure switch failed closed - Refer to troubleshooting in installation instruction.	Check high pressure switch for closed contacts, measure inches of water column of operating pressure, inspect vent and combustion air inducer for correct operation and restriction.
E227	Low pressure switch open during trial for ignition or run mode. Refer to troubleshooting in installation instruction.	Check inches of water column pressure during operation of low pressure switch on heat call, measure inches of water column of operating pressure, inspect vent and combustion air inducer for correct operation and restriction.
E228	Unable to perform successful pressure switch calibration.	Retry after 300 seconds. Error counter cleared when exiting lockout, unable to perform pressure switch calibration. Check vent system and pressure switch wiring connections.
E240	Low flame current - Run mode - Refer to troubleshooting in installation instruction.	Check micro amperes of flame sensor, clean or replace sensor. Measure voltage of neutral to ground for good unit ground. See TABLE 39.
E241	Flame sensed out of sequence - Flame still present.	Shut off gas, check for gas valve leak.
E250	Limit switch circuit open - Refer to troubleshooting in installation instruction.	Check why limit is tripping, overfired, low air flow.
E252	Discharge air temperature too high (gas heat only).	Check temperature rise, air flow and input rate.
E270	Soft lockout - Exceeded maximum number of retries. No flame current sensed.	Check for gas flow, ignitor lighting burner, flame sensor current.
E271	Soft lockout - Exceeded maximum number of retries. Last retry failed due to the pressure switch opening.	See E 223.
E272	Soft lockout - Exceeded maximum number of recycles. Last recycle due to the pressure switch opening.	See E 223 and E 225.

Integrated Control Diagnostic Codes (Continued)

Code	Diagnostic Codes/Status of Equipment	Action Required to Clear and Recover
E273	Soft lockout - Exceeded maximum number of recycles. Last recycle due to flame failure.	See E 240.
E274	Soft lockout - Exceeded maximum number of recycles. Last recycle failed due to the limit circuit opening or limit remained open longer than 3 minutes.	See E 250.
E275	Soft lockout - Flame sensed out of sequence from code 241 fault. Flame signal is gone.	See E 241.
E276	Soft lockout - Exceeded maximum number of calibration retries.	See E 228.
E290	Ignitor circuit fault - Failed ignitor or triggering circuitry.	See E 207.
E291	Restricted air flow - Cubic feet per minute is lower than what is needed for minimum firing rate.	Check for dirty filter, unit air flow restriction, blower performance.
E292	Indoor blower motor unable to start - Seized bearings, stuck wheel, etc.	Indoor blower motor unable to start (seized bearing, stuck wheel, etc), replace motor or wheel if assembly does not operate or meet performance.
E294	Combustion air inducer motor amp draw is too high.	Check combustion blower bearings, wiring , amperes, replace if it does not operate or meet performance.
E295	Indoor blower motor temperature is too high.	Indoor blower motor over temperature (motor tripped on internal protector), Check motor bearings, amperes. Replace if necessary.
E310	Discharge error sensor failure - No error if disconnected. Only shown if shorted or out-of-range.	Discharge air temperature(DATS) out of range, code is activated during "Field test mode".
E311	Heat rate reduced to match indoor blower air flow. Replace filter or repair duct restriction.	Furnace blower in cutback mode due to restricted airflow. Check filter and ductwork. To clear replace filter if needed or repair/ add ductwork.
E312	Restricted air flow in cooling or continuous fan mode is lower than cfm setting.	Restricted airflow - Indoor blower is running at a reduced cubic feet per minute (Cutback Mode) - The variable speed motor has pre-set speed and torque limiters to protect the motor from damage caused by operating out of its designed parameters (0 to 0.8 inches water column total external static pressure). Check filter and ductwork. To clear replace filter if needed or repair/ add ductwork.
E313	Indoor or outdoor unit capacity mismatch.	Incorrect Indoor /outdoor capacity code selected. Check for proper configuration in installation instructions. Alarm is just a warning. The system operation is not impacted at all and alarm would clear when Commissioning is exited.
E331	Global network connection - Communication link problem.	For Future Use.
E345	O Relay Failure	Replace Integrated Control
E347	No 24 Volt output on Y1 to C with non-communicating outdoor unit.	Y1 relay / Stage 1 failed (Pilot relay contacts did not close or the relay coil did not energize).
E348	No 24 Volt output on Y2 to C with non-communicating outdoor unit.	Y2 relay / Stage 2 failed (Pilot relay contacts did not close or the relay coil did not energize).
E370	Interlock switch sensed open for 2 minutes	Control sees the loss of 24VAC for 2 minutes. Terminate all services and wait for interlock switch to close. The alarm will clear when 24VAC is continuously sensed on DS terminal for a minimum of 10 seconds or on a power reset.

Integrated Control Diagnostic Codes LOW GWP

Code	Diagnostic Codes / Status of Equipment	Action Required to Clear and Recover
E150	Refrigerant Leak detected	This may indicate the presence of a leak at or in the indoor unit coil of the equipment, that will need to be repaired for proper and safe system operation. Additionally, it may indicate that proper refrigerant charge will need to be verified. This fault cannot be cleared while the refrigerant detection system sensor is reporting the presence of a leak
E151	Refrigerant Leak Detector Sensor #1 fault	The refrigerant detection sensor #1 in the unit is reporting an issue that prevents it from functioning properly, and replacement of the sensor may be necessary. This fault clears when the sensor no longer reports the presence of a fault condition.
E152	Refrigerant Leak Detector Sensor #2 fault	The refrigerant detection sensor #2 in the unit is reporting an issue that prevents it from functioning properly, and replacement of the sensor may be necessary. This fault clears when the sensor no longer reports the presence of a fault condition.
E154	Refrigerant Leak Detector Sensor #1 Communication lost or invalid sensor dip switch configuration (Disable/Enable)	There may be an issue with the wiring harness connecting the sensor #1 to the furnace control board, either with the wiring itself or with the connector. Check the wiring and the connector for damage or improper connectivity. Check the sensor for damage or obstruction on the harness plug. This fault clears when communications with the sensor has been reestablished, but blower latches for a minimum of 5 minutes. Retest of the presence of fault can be effected by pressing the Low GWP test button on the furnace unit control board. This may also indicate incorrect Low GWP dip switch settings. Please refer to installation instructions.
E155	Refrigerant Leak Detector Sensor #2 Communication lost	There may be an issue with the wiring harness connecting the sensor #2 to the furnace control board, either with the wiring itself or with the connector. Check the wiring and the connector for damage or improper connectivity. Check the sensor for damage or obstruction on the harness plug. This fault clears when communications with the sensor has been reestablished, but blower latches for a minimum of 5 minutes. Retest of the presence of fault can be effected by pressing the Low GWP test button on the furnace unit control board
E160	Refrigerant Leak Detector Sensor #1 type incorrect	The sensor #1 is of a type not suitable for use in the application. Replace the sensor with a Lennox approved replacement part. This fault clears when a sensor suitable for the application is detected by the furnace control board, but blower will latch for a minimum of 5 minutes. Retest of the presence of the fault can be effected by pressing the Low GWP test button on the furnace unit control board.
E161	Refrigerant Leak Detector Sensor #2 type incorrect	The sensor #2 is of a type not suitable for use in the application. Replace the sensor with a Lennox approved replacement part. This fault clears when a sensor suitable for the application is detected by the furnace control board, but blower will latch for a minimum of 5 minutes. Retest of the presence of the fault can be effected by pressing the Low GWP test button on the furnace unit control board.
E163	Furnace Control Board Failure	There is an issue with the furnace control board, preventing the furnace from operating properly. This may require the replacement of the indoor unit control board. This fault clears when the furnace controller operates normally.
E164	Low GWP Test	Low GWP Test mode activates by manually engaging Low GWP test button. Normal operations resumes and code clears automatically after 1-minute
E390	Low GWP Relay Stuck	This indicates an issue with the Low GWP relay in the furnace control. This may require the replacement of the indoor unit control board. This fault clears when the relay operates normally.

TABLE 19

Thermostat Selection Switch Settings

Operation	Thermostat	Switch 1	Switch 2	Switch 3
Variable Capacity Heat (35% to 100%)	Two-Stage	Off	On	Off
Three-Stage Heat (35%, 70%, 100%)	Single-Stage	On	Off	2nd stage delay OFF = 7 minutes ON = 12 minutes 3rd stage delay 10 minutes fixed
Two-Stage Heat (W1 70%, W2 100%)	Two-Stage	Off	Off	Off

NOTE - When the SLP99UHVK is used with a communicating thermostat, all indoor blower speed selections and DIP switch settings are made by the thermostat.

SLP99UHVK units are equipped with an integrated control. This control manages ignition timing, combustion air inducer speed, heating mode fan off delays and indoor blower speeds based on selections made using a communicating thermostat or the control DIP switches and on-board links. The control includes an internal Watchguard feature which automatically resets the ignition control when it has been locked out.

NOTE - All DIP switches are factory shipped in the "OFF" position.

Heating Operation DIP Switch Settings -- FIGURE 58 Switch 1 -- Thermostat Selection -- This unit may be used with either a single-stage or two-stage thermostat. The thermostat selection is made using a DIP switch which must be properly positioned for the particular application. The DIP switch is factory-positioned for use with a two-stage thermostat. If a single-stage thermostat is to be used, the DIP switch must be repositioned. See TABLE 19.

Switch 2 -- Operating Mode with Two-Stage Thermostat -- If a two-stage thermostat is used, the furnace can operate in either variable-capacity or conventional two-stage mode. When variable-capacity mode is selected, the firing rate of the unit is varied to maximize comfort. Conventional two-stage mode is the factory default setting. See TABLE 19.

Switch 3 -- Second-Stage Heat On Delay -- If a single-stage thermostat is used, the integrated control can be used to energize second-stage heat after either 7 minutes or 12 minutes of first-stage heat operation. See TABLE 19.

Switches 4 and 5 -- Blower-Off Delay -- The blower-on delay of 30 seconds is not adjustable. The blower-off delay (time that the blower operates after the heating demand has been satisfied) can be adjusted by moving switches 4

and 5 on the integrated control. The unit is shipped from the factory with a blower-off delay of 120 seconds. The blower off delay affects comfort and is adjustable to satisfy individual applications. Adjust the blower off delay to achieve a supply air temperature between 90° and 110°F at the exact moment that the blower is de-energized. Longer off delay settings provide lower supply air temperatures; shorter settings provide higher supply air temperatures. TABLE 20 provides the blower-off timings that will result from different switch settings.

TABLE 20

Blower-Off Delay Switch Settings

Blower-Off Delay (Seconds)	Switch 4	Switch 5
90	Off	On
120 (factory)	Off	Off
180	On	Off
210	On	On

Indoor Blower Operation DIP Switch Settings

Switches 6 and 7 -- Continuous Indoor Fan Operation Blower Speed -- The unit is shipped from the factory with the DIP switches positioned for medium low (2) speed during continuous indoor blower operation. The table below provides the continuous blower speeds that will result from different switch settings. Refer to tables beginning on page 49 for corresponding cfm values.

TABLE 21

Continuous Indoor Blower Operation -- Blower Speeds

Speed	Switch 6	Switch 7
1 - Low (28%)*	Off	On
2 - Medium Low (38%)* Factory	Off	Off

* Percentage of high speed cooling

Switches 8 and 9 - Cooling Mode Blower Speed

The unit is shipped from the factory with the DIP switches positioned for high speed (4) indoor blower motor operation during the cooling mode. The table below provides the cooling mode blower speeds that will result from different switch settings. Refer to tables beginning on page 49 for corresponding cfm values.

TABLE 22
Cooling Mode Blower Speeds

Speed	Switch 8	Switch 9
1 - Low	On	On
2 - Medium Low	Off	On
3 - Medium High	On	Off
4 - High Factory	Off	Off

Switches 10 and 11 - Cooling Mode Blower Speed Adjustment

The unit is shipped from the factory with the DIP switches positioned for NORMAL (no) adjustment. The DIP switches may be positioned to adjust the blower speed by +10% or -10% to better suit the application. TABLE 23 provides blower speed adjustments that will result from different switch settings. Refer to tables beginning on page 44 for corresponding cfm values.

With switches 10 and 11 set to ON, motor will bypass ramping profiles and all delays and will immediately run at selected COOLING speed upon a call for cool. LED will continue to operate as normal. This mode is used to check motor operation.

TABLE 23
Cooling Mode Blower Speed Adjustment

Adjustment	Switch 10	Switch 11
+10% (approx.)	On	Off
Default Cool CFM	Off	Off
-10% (approx.)	Off	On
Motor Test	On	On

Switches 12 and 13 - Cooling Mode Blower Speed Ramping

Blower speed ramping may be used to enhance dehumidification performance. The switches are factory set at option A which has the greatest effect on blower motor performance. TABLE 24 provides the cooling mode blower speed ramping options that will result from different switch settings. The cooling mode blower speed ramping options are detailed below.

NOTE - The off portion of the selected ramp profile only applies during heat pump operation in dual fuel applications.

TABLE 24

Cooling Mode Blower Speed Ramping

Ramping Option	Switch 12	Switch 13
A (factory)	Off	Off
B	On	Off
C	Off	On
D	On	On

Ramping Option A (Factory Selection)

- Motor runs at 50% for 30 seconds.
- Motor then runs at 82% for approximately 7-1/2 minutes.
- If demand has not been satisfied after 7-1/2 minutes, motor runs at 100% until demand is satisfied.
- Once demand is met, motor runs at 50% for 30 seconds then ramps down to stop.

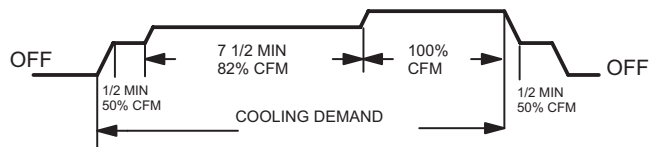

Ramping Option B

- Motor runs at 82% for approximately 7-1/2 minutes. If demand has not been satisfied after 7-1/2 minutes, motor runs at 100% until demand is satisfied.
- Once demand is met, motor ramps down to stop.



Ramping Option C

- Motor runs at 100% until demand is satisfied.
- Once demand is met, motor runs at 100% for 45 seconds then ramps down to stop.

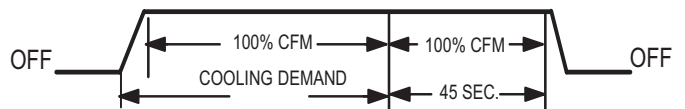

Ramping Option D

- Motor runs at 100% until demand is satisfied.
- Once demand is met, motor ramps down to stop.

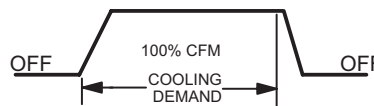

Switches 14 through 19 -- Heating Mode Blower Speed

These switches are factory set at the OFF position which provides 100 % of normal speed during HIGH HEAT demand, 70% of normal speed during MID-RANGE HEAT demand and 35% of normal speed during LOW HEAT demand. Switches 14, 15 and 16 are used to adjust the LOW HEAT blower motor speed. Switches 17, 18 and 19 are used to adjust the HIGH HEAT blower motor speed. See tables below for heating mode blower speeds that will result from different switch settings. Refer to tables beginning on page 49 for corresponding cfm values.

TABLE 25
Low Heat Blower Speeds

Thermostat Demand	Blower Speed Adjustments	DIP Switch Settings		
		14	15	16
Low Heat (R to W1)	+ 15%	On	Off	On
	+ 7.5%	On	Off	Off
	Normal	Off	Off	Off
	- 7.5%	On	On	Off
	- 15%	On	On	On

TABLE 26
High Heat Blower Speeds

Thermostat Demand	Blower Speed Adjustments	DIP Switch Settings		
		17	18	19
High Heat (R to W1 & W2)	+ 15%	On	Off	On
	+ 7.5%	On	Off	Off
	Normal	Off	Off	Off
	- 7.5%	On	On	Off
	- 15%	On	On	On

On-Board Links

On-Board links must be clipped (when applicable) before unit is placed into operation with a non-communicating thermostat.

On-Board Link W914 DS to R (FIGURE 58)

On-board link W914, is a clippable connection between terminals DS and R on the integrated control. W914 must be cut when the furnace is installed with either the Harmony III zone control or a thermostat which features humidity control. If the link is left intact the PMW signal from the Harmony III control will be blocked and also lead to control damage. See TABLE 32 for operation sequence in applications including SLP99UHVK, a thermostat which features humidity control and a single-speed outdoor unit. TABLE 33 gives the operation sequence in applications with a two-speed outdoor unit.

On-Board Link W951 R to O (FIGURE 58)

On-board link W951 is a clippable connection between terminals R and O on the integrated control. W951 must be cut when the furnace is installed in applications which include a heat pump unit and a thermostat which features dual fuel use. If the link is left intact, terminal "O" will remain energized eliminating the HEAT MODE in the heat pump.

On-Board Jumper Y1 to Y2 (FIGURE 58)

On-board jumper is clippable between terminals Y1 and Y2 on the integrated control. The jumper must be cut if two-stage cooling will be used. If the link is not cut the outdoor unit will operate in second-stage cooling only.

Diagnostic LED (FIGURE 58)

The seven-segment diagnostic LED displays operating status, target airflow, error codes and other information.

Diagnostic Push Button (FIGURE 58)

The diagnostic push button is located adjacent to the seven-segment diagnostic LED. This button is used to enable the Error Code Recall mode and the Field Test mode. Press the button and hold it to cycle through a menu of options. Every five seconds a new menu item will be displayed. When the button is released, the displayed item will be selected. Once all items in the menu have been displayed, the menu resumes from the beginning until the button is released.

Error Code Recall Mode

Select "E" from the menu to access the most recent 10 error codes. Select "c" from the Error Code Recall menu to clear all error codes. Button must be pressed a second time while "c" is flashing to confirm command to delete codes. Press the button until a solid "≡" is displayed to exit the Error Code Recall mode.

Field Test Mode

Use the diagnostic push button to scroll through the menu as described above. Release the button when the LED flashes "-" to select the Field Test mode.

While in the Field Test mode the technician can:

- Initiate furnace ignition and move to and hold low-fire rate by applying a R to W1 jumper.
- Initiate furnace ignition sequence and move to and hold high-fire rate by applying a jumper from R to W1 and W2.
- Initiate furnace ignition sequence and move to and hold mid-fire rate by applying a jumper to R and W2.
- Apply then remove the jumper from R to W1 and W2 to change the firing rate from low fire to mid fire and high fire.
- A vent calibration sequence can be initiated even if a thermostat signal is not present. Press and hold the push button until a solid "C" is displayed. Release the button and calibration will begin. The furnace will perform the high-fire and low-fire pressure switch calibrations and display "CAL". After calibration, the LED will return to the flashing "-" display.

During Field Test mode operation, all safety switches are still in the circuit (they are not by-passed) and indoor blower performance and timings will match DIP switch selections. Current furnace firing rate, indoor blower CFM and flame signal will be displayed. To exit the Field Test mode, press and hold the button. The menu will resume from the beginning. Also, cycle the main power to exit the Field Test mode. The integrated control will automatically exit the Field Test mode after 45 minutes of operation.

Low GWP Application

⚠ WARNING

For use with Lennox approved evaporator coil and LGWP sensors only. Use original manufacturer recommended LGWP sensors if using non Lennox approved evaporator coil.

CONNECTING THE FURNACE CONTROL BOARD SENSOR.

See **FIGURE 61** and follow steps below:

- 1 - Route sensor wire #1 through provided grommet. Form a drip loop below the control board on upflow installations to prevent condensate dripping on the control board.
- 2 - Avoid sharp edges when routing sensor wire during installation.
- 3 - Sensor wire must not block view of 7 segment LED .

Ensure the cable is properly seated into the LGWP1 sensor plug. The Molex plug clip should lock into the Molex connection point for a secured connection, as shown below in **FIGURE 59**. Verify the connection is free of dust, debris, and moisture.

NOTE - In confined space applications, connect the second sensor to the LGWP2 sensor plug. Refer to evaporator coil installation instructions for more detail.

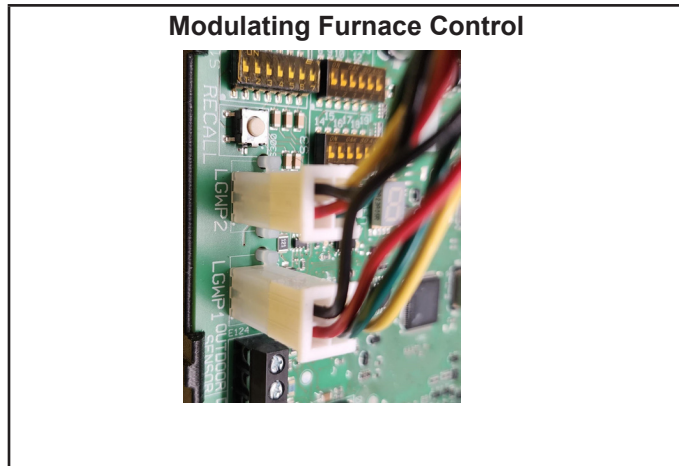

FIGURE 59

LOW GWP DIP SWITCH SETTINGS

Adjust the DIP switch settings to the sensor configuration. Failure to do so will cause faults on power-up. See **FIGURE 60** and **TABLE 27**.

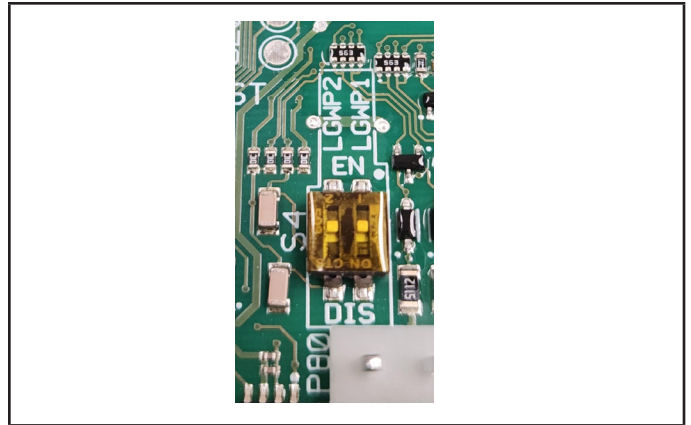

FIGURE 60

TABLE 27

DIP Switch Settings

Configuration	LGWP1	LGWP2
One (1) sensor, connected to SENSOR 1 plug	Enable	Disable
Two (2) sensors, connected to SENSOR 1 plug and SENSOR 2 plug	Enable	Enable
No sensor R410A or heat only applications	Disable	Disable
Invalid Configuration	Disable	Enable

In single sensor configurations, the sensor must be connected to the LGWP1 plug. Configurations other than the ones shown in **TABLE 27** will cause a servicing fault.

Each DIP switch corresponds to a sensor position (i.e., DIP switch LGWP1 to LGWP1 to sensor PLUG; and DIP switch LGWP2 to LGWP2 sensor plug. The default factory switch positions are set to ENABLE.

The furnace control board software reads the ENABLE position as an active sensor. A sensor should be present for the corresponding sensor plug. Setting the DIP switch to DISABLE position disables the sensor position.

SECONDARY SENSOR REQUIREMENTS

Additional Line Sets

If additional refrigerant line joints are present outside of the line set sleeve and a secondary refrigerant detection sensor is required, its installation must comply with the requirement listed in Refrigeration Detection Sensor kit (27V53). See **FIGURE 60** for routing the secondary sensor cable through the furnace cabinet.

Non-Low GWP Applications

⚠ WARNING

For Furnace only applications or Furnace replacement in a Non-Low GWP applications, the LOW GWP sensors should be disabled, otherwise the blower will operate continuously. To do this, the Low GWP Dip switches setting for both – Sensor 1 and the Sensor 2 must be moved to the DISABLE position.

FURNACE CONTROL BOARD LOW GWP MODES OF OPERATION

The modes of operation for the furnace control board are Initializing, Normal, Leak Detected, and Fault.

Initializing

The furnace control board is establishing connection with the refrigerant detection sensor and is completing an initial five-minute purge sequence.

Normal

The HVAC system is functioning normally. The furnace control board has not detected a refrigerant leak.

Leak Detected

When the furnace control board detects a refrigerant leak:

1. The furnace control board shuts off the (R) input (24VAC power) to the thermostat, which de-energizes the outdoor unit compressor and heat sources, such as gas and/or electric strip heat. No heating or cooling demands will be met.

2. The furnace control board activates the blower (high speed). The blower purges refrigerant from the cabinet, plenum, and ductwork.
3. After the furnace control board determines the refrigerant levels are below the safety threshold, the blower will continue to operate for the remainder of the seven (7) -minute cycle.
4. After the blower sequence is complete, the HVAC system resumes normal operation.

NOTE - The HVAC system may not maintain a cooling or heating set point if a significant leak exists. Any refrigerant leaks that remain unaddressed for an extended time may cause the HVAC system to shut down on a low refrigerant pressure limit condition.

Fault

When a Low GWP fault is detected by the furnace control board, the indoor unit blower engages and remains engaged at a constant air flow output until the fault is cleared.

NOTE - See page 42 for diagnostic codes.

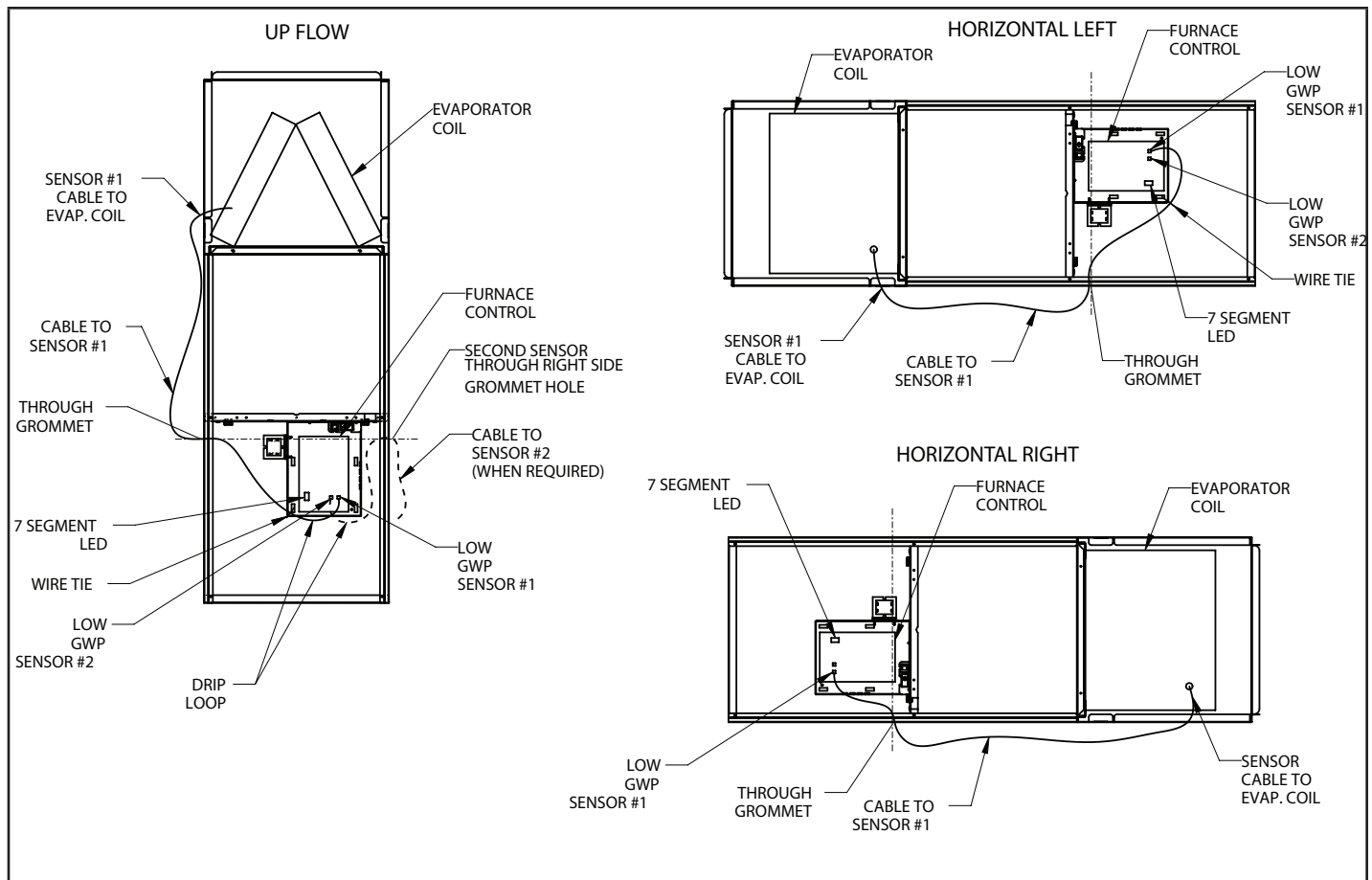

FIGURE 61

LGWP TEST BUTTON FUNCTIONALITY

The furnace control board is equipped with a Test/Reset push button. The Test button can be used to perform several functions, depending on the mode of operation of the furnace control board.

TABLE 28 lists the functions of the Test button during each mode of operation.

TABLE 28
LGWP Test Button Function

Mode of Operation	Press the Test Button to:
Normal	Trigger a leak detection response. Verify all equipment is wired correctly into the furnace blower control board (after installation).
Leak Detected	Reset the furnace control board to a normal mode of operation after a previous leak has been detected and purged from the HVAC system
Fault	Reset the furnace control board after troubleshooting and resolving a fault condition. If the fault is not resolved, the furnace control board will enter the Fault mode again.

LGWP Test Button - Additional Functions

TABLE 29 lists the additional functions of the Test Button while the furnace control board is functioning within the states of Initializing, Monitoring, Leak Detection, Servicing and Fault.

TABLE 29
Additional Button Functions

State	Press	Action
Initializing	Short	Skips remaining pre-purge after sensors are recognized by the furnace control board
Initializing	Long	Reset control
Monitoring	Short	Clear purge-counter if prior mitigation has occurred; Test mitigation
Monitoring	Long	Reset control
Mitigating	Short	If testing mitigation, end test
Servicing	Short	Reevaluate fault condition - if cleared return to monitoring, otherwise update indicator
Servicing	Long	Reset control
Fault	Short	Reevaluate fault condition - if cleared return to monitoring, otherwise update indicator
Fault	Long	Reset control

External Alarm

(For applications with external alarms wired directly to the furnace control board)

The furnace control board triggers the external alarm system when it enters Leak Detected mode. For alarm notifications, the furnace control board provides a dry relay contact that is rated 3A at 30 VAC/DC.

THERMOSTAT COMPATIBILITY

Thermostats that preserve memory settings are compatible with the furnace control board. Examples include:

- Battery-powered thermostats
- Analog Thermostat
- Late-model programmable thermostats

NOTE - Early-generation digital and programmable thermostats may not retain the operation mode and temperature setpoints after a power outage.

The following scenarios are likely to occur when home occupants are not available to adjust the thermostat setpoints as the system is recovering from leak detection and resuming normal operation:

- Heating could be lost during a cold night
- Cooling could be lost during a hot day
- The thermostat could reset to an incorrect temperature setpoint

START UP PROCEDURE

The furnace control board is equipped with a LGWP Test/Reset button, see Test Button Functionality. After the furnace control board has been mounted and wired, restore power to the HVAC system. The system will then run through a purge sequence for five minutes. After the purge sequence is complete, proceed to testing cooling demand and heating demand.

Cooling Demand

1. Prompt a cooling demand at the thermostat.
2. Press the LGWP Test button on the furnace control board.
The system then executes a leak detection response.
3. Observe the following sequence:
 - a. The LED indicator for leak detection. See page 42 for diagnostic codes.
 - b. The blower powers up.
 - c. The outdoor compressor powers down.
4. Press the LGWP Test button to terminate the simulated Leak Detected mode upon test completion

Heating Demand

1. Prompt a heating demand at the thermostat.
2. Observe the following sequence:
 - a. The LED indicator for leak detection. See page 42 for diagnostic codes.
 - b. The blower powers up.
 - c. The gas burners power down.
 - d. The outdoor compressor powers down.
3. Press the LGWP Test button to terminate the simulated Leak Detected mode upon test completion.

The installation of the furnace control board is complete after.

BLOWER DATA

SLP99UH070XV36BK BLOWER PERFORMANCE (less filter)

BOTTOM RETURN AIR

HEATING BLOWER PERFORMANCE - 0 through 0.8 in. w.g. External Static Pressure Range

Heating Adjust CFM Selections	Heating Input Range and Blower Volume - CFM							
	35%	40%	50%	60%	70%	80%	90%	100%
Increase (+15%) Heat CFM	489	538	636	735	833	931	1030	1128
Increase (+7.5%) Heat CFM	450	496	588	680	772	864	956	1048
Default Heat CFM	410	453	539	624	710	796	881	967
Decrease (-7.5%) Heat CFM	380	419	498	578	657	736	815	895
Decrease (-15%) Heat CFM	349	385	458	531	604	676	749	822

COOLING BLOWER PERFORMANCE - 0 through 1.0 in. w.g. External Static Pressure Range

Cooling Adjust CFM Selections	Blower Speed Selections							
	First Stage Cool Speed - cfm				Second Stage Cool Speed - cfm			
	Low	Medium-Low	Medium High	High (Default)	Low	Medium-Low	Medium High	High (Default)
Increase (+10%) Cool CFM	610	745	865	995	900	1070	1235	1405
Default Cool CFM	560	675	785	890	810	970	1125	1265
Decrease (-10%) Cool CFM	510	615	700	795	720	875	1015	1145

BLOWER DATA

SLP99UH090XV36CK BLOWER PERFORMANCE (less filter)

BOTTOM RETURN AIR

HEATING BLOWER PERFORMANCE - 0 through 0.8 in. w.g. External Static Pressure Range

Heating Adjust CFM Selections	Heating Input Range and Blower Volume - CFM							
	35%	40%	50%	60%	70%	80%	90%	100%
Increase (+15%) Heat CFM	687	734	827	921	1014	1108	1201	1295
Increase (+7.5%) Heat CFM	654	697	782	867	953	1038	1123	1209
Default Heat CFM	621	660	737	814	891	968	1045	1122
Decrease (-7.5%) Heat CFM	581	616	687	757	828	899	970	1041
Decrease (-15%) Heat CFM	540	572	637	701	766	830	895	959

COOLING BLOWER PERFORMANCE - 0 through 1.0 in. w.g. External Static Pressure Range

Cooling Adjust CFM Selections	Blower Speed Selections							
	First Stage Cool Speed - cfm				Second Stage Cool Speed - cfm			
	Low	Medium-Low	Medium High	High (Default)	Low	Medium-Low	Medium High	High (Default)
Increase (+10%) Cool CFM	640	750	835	950	875	1040	1185	1365
Default Cool CFM	600	695	775	855	800	940	1090	1220
Decrease (-10%) Cool CFM	540	640	710	785	715	850	980	1105

The effect of static pressure is included in air volumes shown.

The following control configurations are available. See Installation Instructions for details and DIP switch settings.

Heat Modes Available (Heating Blower Performance Table):

Single stage thermostat:

- 35%, 70%, 100% input (three-stage) with time delays in-between.

Two-stage thermostat:

- Variable Rate Capacity Mode - furnace automatically adjusts firing rate based on first- and second-stage cycle times.
- W1 demand at 70% input, W2 demand at 100% input. No delay between stages.

Cool Mode Available (Cooling Blower Performance table):

- First stage COOL (two-stage air conditioning units only) is approximately 70% of the same second stage COOL speed position.
- Continuous Fan speeds are approximately 28% and 38% (DIP switch selectable) of the same second-stage COOL speed position. minimum 250 cfm.

Lennox iHarmony® Zoning System Applications - Minimum blower speed is 250 cfm.

SLP99UH090XV48CK BLOWER PERFORMANCE (less filter)

BOTTOM RETURN AIR

HEATING BLOWER PERFORMANCE - 0 through 0.8 in. w.g. External Static Pressure Range

Heating Adjust CFM Selections	Heating Input Range and Blower Volume - CFM							
	35%	40%	50%	60%	70%	80%	90%	100%
Increase (+15%) Heat CFM	769	835	968	1101	1234	1367	1500	1633
Increase (+7.5%) Heat CFM	713	776	902	1028	1155	1281	1407	1534
Default Heat CFM	656	716	836	955	1075	1195	1314	1434
Decrease (-7.5%) Heat CFM	595	652	767	882	997	1112	1227	1342
Decrease (-15%) Heat CFM	534	589	699	809	919	1029	1139	1249

COOLING BLOWER PERFORMANCE - 0 through 1.0 in. w.g. External Static Pressure Range

Cooling Adjust CFM Selections	Blower Speed Selections							
	First Stage Cool Speed - cfm				Second Stage Cool Speed - cfm			
	Low	Medium-Low	Medium High	High (Default)	Low	Medium-Low	Medium High	High (Default)
Increase (+10%) Cool CFM	815	975	1095	1270	1125	1375	1565	1785
Default Cool CFM	745	885	1005	1145	1030	1235	1445	1615
Decrease (-10%) Cool CFM	675	810	910	1040	950	1115	1305	1480

BLOWER DATA

SLP99UH090XV60CK BLOWER PERFORMANCE (less filter)

BOTTOM RETURN AIR

HEATING BLOWER PERFORMANCE - 0 through 0.8 in. w.g. External Static Pressure Range

Heating Adjust CFM Selections	Heating Input Range and Blower Volume - CFM							
	35%	40%	50%	60%	70%	80%	90%	100%
Increase (+15%) Heat CFM	583	665	830	995	1159	1324	1488	1653
Increase (+7.5%) Heat CFM	540	618	774	930	1085	1241	1397	1553
Default Heat CFM	497	571	718	865	1012	1159	1306	1453
Decrease (-7.5%) Heat CFM	439	507	644	781	917	1054	1191	1328
Decrease (-15%) Heat CFM	380	443	570	697	823	950	1076	1203

COOLING BLOWER PERFORMANCE - 0 through 1.0 in. w.g. External Static Pressure Range

Cooling Adjust CFM Selections	Blower Speed Selections							
	First Stage Cool Speed - cfm				Second Stage Cool Speed - cfm			
	Low	Medium-Low	Medium High	High (Default)	Low	Medium-Low	Medium High	High (Default)
Increase (+10%) Cool CFM	1105	1280	1400	1590	1590	1820	2025	2270
Default Cool CFM	1015	1165	1285	1425	1425	1635	1855	2035
Decrease (-10%) Cool CFM	920	1055	1165	1295	1290	1470	1655	1855

The effect of static pressure is included in air volumes shown.

The following control configurations are available. See Installation Instructions for details and DIP switch settings.

Heat Modes Available (Heating Blower Performance Table):

Single stage thermostat:

- 35%, 70%, 100% input (three-stage) with time delays in-between.

Two-stage thermostat:

- Variable Rate Capacity Mode - furnace automatically adjusts firing rate based on first- and second-stage cycle times.
- W1 demand at 70% input, W2 demand at 100% input. No delay between stages.

Cool Mode Available (Cooling Blower Performance table):

First stage COOL (two-stage air conditioning units only) is approximately 70% of the same second stage COOL speed position.

Continuous Fan speeds are approximately 28% and 38% (DIP switch selectable) of the same second-stage COOL speed position. minimum 380 cfm.

Lennox® Smart Zoning System Applications - Minimum blower speed is 450 cfm.

BLOWER DATA

SLP99UH110XV60CK BLOWER PERFORMANCE (less filter)

BOTTOM RETURN AIR

HEATING BLOWER PERFORMANCE - 0 through 0.8 in. w.g. External Static Pressure Range

Heating Adjust CFM Selections	Heating Input Range and Blower Volume - CFM							
	35%	40%	50%	60%	70%	80%	90%	100%
Increase (+15%) Heat CFM	767	861	1049	1237	1424	1612	1800	1988
Increase (+7.5%) Heat CFM	738	825	1000	1174	1349	1524	1699	1874
Default Heat CFM	708	789	951	1112	1274	1436	1597	1759
Decrease (-7.5%) Heat CFM	655	731	883	1035	1187	1339	1491	1644
Decrease (-15%) Heat CFM	602	673	816	958	1101	1243	1386	1528

COOLING BLOWER PERFORMANCE - 0 through 1.0 in. w.g. External Static Pressure Range

Cooling Adjust CFM Selections	Blower Speed Selections							
	First Stage Cool Speed - cfm				Second Stage Cool Speed - cfm			
	Low	Medium-Low	Medium High	High (Default)	Low	Medium-Low	Medium High	High (Default)
Increase (+10%) Cool CFM	1050	1200	1305	1485	1490	1705	1915	2130
Default Cool CFM	960	1100	1205	1335	1340	1540	1750	1925
Decrease (-10%) Cool CFM	860	995	1100	1220	1220	1390	1570	1750

BLOWER DATA

SLP99UH135XV60DK BLOWER PERFORMANCE (less filter)

BOTTOM RETURN AIR

HEATING BLOWER PERFORMANCE - 0 through 0.8 in. w.g. External Static Pressure Range

Heating Adjust CFM Selections	Heating Input Range and Blower Volume - CFM							
	35%	40%	50%	60%	70%	80%	90%	100%
Increase (+15%) Heat CFM	949	1033	1200	1367	1534	1701	1868	2035
Increase (+7.5%) Heat CFM	879	957	1113	1269	1426	1582	1738	1895
Default Heat CFM	808	881	1026	1172	1317	1463	1608	1754
Decrease (-7.5%) Heat CFM	748	817	956	1095	1235	1374	1513	1652
Decrease (-15%) Heat CFM	687	753	886	1019	1152	1284	1417	1550

COOLING BLOWER PERFORMANCE - 0 through 1.0 in. w.g. External Static Pressure Range

Cooling Adjust CFM Selections	Blower Speed Selections							
	First Stage Cool Speed - cfm				Second Stage Cool Speed - cfm			
	Low	Medium-Low	Medium High	High (Default)	Low	Medium-Low	Medium High	High (Default)
Increase (+10%) Cool CFM	1080	1240	1380	1570	1565	1790	2000	2250
Default Cool CFM	995	1130	1250	1415	1415	1615	1825	2010
Decrease (-10%) Cool CFM	900	1025	1130	1255	1265	1460	1640	1825

The effect of static pressure is included in air volumes shown.

The following control configurations are available. See Installation Instructions for details and DIP switch settings.

Heat Modes Available (Heating Blower Performance Table):

Single stage thermostat:

- 35%, 70%, 100% input (three-stage) with time delays in-between.

Two-stage thermostat:

- Variable Rate Capacity Mode - furnace automatically adjusts firing rate based on first- and second-stage cycle times.
- W1 demand at 70% input, W2 demand at 100% input. No delay between stages.

Cool Mode Available (Cooling Blower Performance table):

First stage COOL (two-stage air conditioning units only) is approximately 70% of the same second stage COOL speed position.
 Continuous Fan speeds are approximately 28% and 38% (DIP switch selectable) of the same second-stage COOL speed position.
 minimum 380 cfm.

Lennox® Smart Zoning System Applications - Minimum blower speed is 450 cfm.

TABLE 30
Allowable Heating Speeds

SLP99UHK Model	-15%	-7.5%	Default	+7.5%	+15%
All Models	Allowed	Allowed	Factory	Allowed	Allowed

TABLE 31
Allowable Circulation Speeds

SLP99UHK Model	28% (Second Stage Cool)	38% (second stage cool)
All Models	Allowed	Factory Setting

TABLE 32
COOLING OPERATING SEQUENCE
SLP99UHVK and Single-Stage Outdoor Unit

OPERATING SEQUENCE		SYSTEM DEMAND			SYSTEM RESPONSE				
System Condition	Step	Thermostat Demand			Relative Humidity		Compressor	Blower CFM (cool)	Comments
		1st stage	O	G	Status	D*			
<i>NO CALL FOR DEHUMIDIFICATION</i>									
Normal Operation	1	On	On	On	Acceptable	24 VAC	High	100%	Compressor and indoor blower follow thermostat demand
<i>BASIC MODE (only active on a Y1 thermostat demand)</i>									
Normal Operation	1	On	On	On	Acceptable	24 VAC	High	100%	Thermostat energizes Y1 and de-energizes D on a call for de-humidification
Dehumidification call	2	On	On	On	Demand	0 VAC	High	70%	
<i>PRECISION MODE (operates independent of a Y1 demand)</i>									
Normal Operation	1	On	On	On	Acceptable	24 VAC	High	100%	Dehumidification mode begins when humidity is greater than set point
Dehumidification Call	2	On	On	On	Demand	0 VAC	High	70%	
Dehumidification Call Only	1	On	On	On	Demand	0 VAC	High	70%	Thermostat will keep outdoor unit energized after cooling temperature setpoint has been reached in order to maintain room humidity setpoint.
On-board links at indoor unit with a single-stage outdoor unit: With Condensing unit - Cut W914 (R to DS) on control; With Heat Pump - Cut W914 (R to DS) & W951 (R to O) on control. *ComfortSense® 7500 thermostat only									

**TABLE 33
OPERATING SEQUENCE
SLP99UHVK and Two-Speed Outdoor Unit**

OPERATING SEQUENCE		SYSTEM DEMAND				SYSTEM RESPONSE				
System Condition	Step	Thermostat Demand				Relative Humidity		Compressor	Blower CFM (cool)	Comments
		1 s t stage	2nd stage	O	G	Status	D*			
NO CALL FOR DEHUMIDIFICATION										
Normal Operation Y1	1	On		On	On	Acceptable	24 VAC	Low	70%	Compressor and indoor blower follow thermostat demand
Normal Operation Y2	2	On	On	On	On	Acceptable	24 VAC	High	100%	
ROOM THERMOSTAT CALLS FOR FIRST STAGE COOLING										
BASIC MODE (only active on a Y1 thermostat demand)										
Normal Operation	1	On		On	On	Acceptable	24 VAC	Low	70%	Thermostat energizes 2nd stage and de-energizes D on a call for dehumidification
Dehumidification call	2	On	On	On	On	Demand	0 VAC	High	70%	
PRECISION MODE (operates independent of a Y1 demand)										
Normal Operation	1	On		On	On	Acceptable	24 VAC	Low	70%	Dehumidification mode begins when humidity is greater than set point
Dehumidification Call	2	On	On	On	On	Demand	0 VAC	High	70%	
Dehumidification Call Only	1	On	On	On	On	Demand	0 VAC	High	70%	Thermostat will keep outdoor unit energized after cooling temperature setpoint has been reached in order to maintain room humidity setpoint.*
ROOM THERMOSTAT CALLS FOR FIRST AND SECOND STAGE COOLING										
BASIC MODE (only active on a Y1 thermostat demand)										
Normal Operation	1	On	On	On	On	Acceptable	24 VAC	High	100%	Thermostat energizes 2nd stage and de-energizes D on a call for dehumidification
Dehumidification Call	2	On	On	On	On	Demand	0 VAC	High	70%	
PRECISION MODE (operates independent of a Y1 thermostat demand)										
Normal Operation	1	On		On	On	Acceptable	24 VAC	Low	70%	Dehumidification mode begins when humidity is greater than set point
Dehumidification Call	2	On	On	On	On	Demand	0 VAC	High	70%	
Dehumidification Call ONLY	1	On	On	On	On	Demand	0 VAC	High	70%	Thermostat will keep outdoor unit energized after cooling temperature set-point has been reached in order to maintain room humidity set-point.
<p>On-board links at indoor unit with a two-stage outdoor unit: Cut factory link from Y1 to Y2 or cut W915 (Y1 to Y2) on integrated control. With Condensing unit - Cut W914 (R to DS) on control; With Heat Pump - Cut W914 (R to DS) & W951 (R to O) on control. *ComfortSense® 7500 thermostat only</p>										

Unit Start-Up

FOR YOUR SAFETY READ BEFORE OPERATING

⚠ WARNING

Do not use this furnace if any part has been underwater. A flood-damaged furnace is extremely dangerous. Attempts to use the furnace can result in fire or explosion. Immediately call a qualified service technician to inspect the furnace and to replace all gas controls, control system parts, and electrical parts that have been wet or to replace the furnace, if deemed necessary.

⚠ WARNING



Danger of explosion. Can cause injury or product or property damage. Should the gas supply fail to shut off or if overheating occurs, shut off the gas valve to the furnace before shutting off the electrical supply.

⚠ CAUTION

Before attempting to perform any service or maintenance, turn the electrical power to unit OFF at disconnect switch.

⚠ WARNING

During blower operation, the ECM motor emits energy that may interfere with pacemaker operation. Interference is reduced by both the sheet metal cabinet and distance.

Priming Condensate Trap

The condensate trap should be primed with water prior to start-up to ensure proper condensate drainage. Either pour 10 fl. oz. (300 ml) of water into the trap, or follow these steps to prime the trap:

- 1 - Follow the lighting instructions to place the unit into operation.
- 2 - Set the thermostat to initiate a heating demand.
- 3 - Allow the burners to fire for approximately 3 minutes.
- 4 - Adjust the thermostat to deactivate the heating demand.
- 5 - Wait for the combustion air inducer to stop. Set the thermostat to initiate a heating demand and again allow the burners to fire for approximately 3 minutes.
- 6 - Adjust the thermostat to deactivate the heating demand and again wait for the combustion air inducer to stop. At this point, the trap should be primed with sufficient water to ensure proper condensate drain operation.

BEFORE PLACING THE UNIT INTO OPERATION, smell all around the furnace area for gas. Be sure to smell next to the floor because some gas is heavier than air and will settle on the floor. The gas valve on the SLP99UHVK is equipped with a gas control switch. Use only your hand to move the control switch. Never use tools. If the switch will not move by hand, do not try to repair it. Force or attempted repair may result in a fire or explosion.

Placing the furnace into operation:

SLP99UHVK units are equipped with an automatic ignition system. Do not attempt to manually light burners on this furnace. Each time the thermostat calls for heat, the burners will automatically light. The ignitor does not get hot when there is no call for heat on units with this ignition system.

⚠ WARNING

If you do not follow these instructions exactly, a fire or explosion may result causing property damage, personal injury or death.

Gas Valve Operation (FIGURE 62)

- 1 - **STOP!** Read the safety information at the beginning of this section.
- 2 - Set the thermostat to the lowest setting.
- 3 - Turn off all electrical power to the unit.
- 4 - This furnace is equipped with an ignition device which automatically lights the burners. Do not try to light the burners by hand.
- 5 - Remove the access panel.
- 6 - Move the gas valve switch to the OFF position. See FIGURE 62.
- 7 - Wait five minutes to clear out any gas. If you then smell gas, **STOP!** Immediately call the gas supplier from a neighbor's phone. Follow the gas supplier's instructions. If you do not smell gas go to next step.
- 8 - Move gas valve switch to the ON position. See FIGURE 62. Do not force.

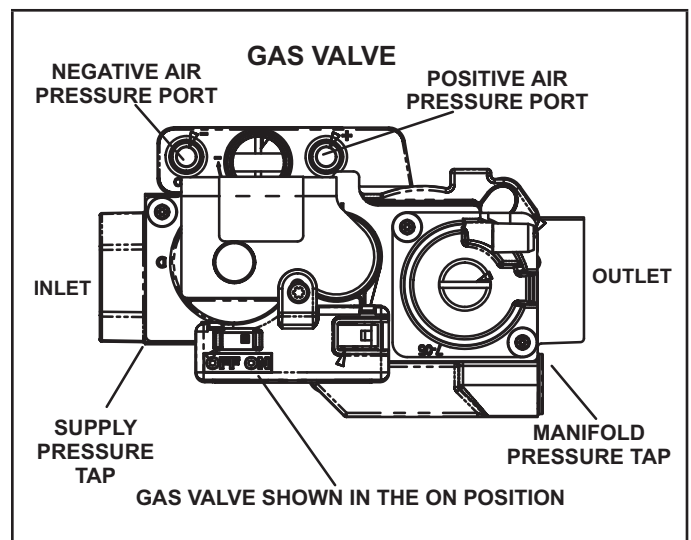

FIGURE 62

- 9 - Replace the access panel.
- 10 - Turn on all electrical power to the unit.
- 11 - Set the thermostat to desired setting.

NOTE - When unit is initially started, steps 1 through 11 may need to be repeated to purge air from gas line.

- 12 - If the appliance will not operate, follow the instructions "Turning Off Gas to Unit" and call the gas supplier.

Turning Off Gas to Unit

- 1 - Set the thermostat to the lowest setting.
- 2 - Turn off all electrical power to the unit if service is to be performed.
- 3 - Remove the access panel.
- 4 - Move the gas valve switch to the OFF position.
- 5 - Replace the access panel.

Failure To Operate

If the unit fails to operate, check the following:

- 1 - Is the thermostat calling for heat?
- 2 - Are access panels securely in place?
- 3 - Is the main disconnect switch closed?
- 4 - Is there a blown fuse?
- 5 - Is the filter dirty or plugged? Dirty or plugged filters will cause the limit control to shut the unit off.
- 6 - Is gas turned on at the meter?
- 7 - Is the manual main shut-off valve open?
- 8 - Is the gas valve turned on?
- 9 - Is the unit ignition system in lock out? If the unit locks out again, inspect the unit for blockages.
- 10 - Is blower harness connected to ignition control? Furnace will not operate unless harness is connected.

Gas Pressure Measurement

Gas Flow (Approximate)

TABLE 34				
GAS METER CLOCKING CHART				
SLP99K Unit	Seconds for One Revolution			
	Natural		LP	
	1 cu ft Dial	2 cu ft Dial	1 cu ft Dial	2 cu ft Dial
-070	55	110	136	272
-090	41	82	102	204
-110	33	66	82	164
-135	27	54	68	136
Natural-1000 btu/cu ft LP-2500 btu/cu ft				

Furnace should operate at least 5 minutes before checking gas flow. Determine time in seconds for two revolutions of gas through the meter. (Two revolutions assures a more accurate time.) Divide by two and compare to time in TABLE 34. If manifold pressure matches TABLE 35 and rate is incorrect, check gas orifices for proper size and restriction. Remove temporary gas meter if installed.

NOTE - To obtain accurate reading, shut off all other gas appliances connected to meter.

Supply Pressure Measurement

A threaded plug on the inlet side of the gas valve provides access to the supply pressure tap. Remove the threaded plug, install a field-provided barbed fitting and connect a manometer to measure supply pressure. Replace the threaded plug after measurements have been taken.

Manifold Pressure Measurement (FIGURE 63)

To correctly measure manifold pressure, the differential pressure between the positive gas manifold and the negative burner box must be considered. Use pressure test adapter kit (available as Lennox part 10L34) to assist in measurement.

- 1 - Remove the threaded plug from the outlet side of the gas valve and install a field-provided barbed fitting. Connect measuring device "+" connection to barbed fitting to measure manifold pressure.
- 2 - Tee into the gas valve regulator vent hose and connect measuring device "-" connection.
- 3 - Start unit on low heat (35% rate) and allow 5 minutes for unit to reach steady state.
- 4 - While waiting for the unit to stabilize, notice the flame. Flame should be stable and should not lift from burner. Natural gas should burn blue.
- 5 - After allowing unit to stabilize for 5 minutes, record manifold pressure and compare to value given in TABLE 35.
- 6 - Repeat steps 3, 4 and 5 on high heat.
- 7 - Shut unit off and remove manometer as soon as an accurate reading has been obtained. Take care to remove barbed fitting and replace threaded plug.
- 8 - Start unit and perform leak check. Seal leaks if found.

CAUTION
 Do not attempt to make adjustments to the gas valve.

Operating Pressure Signal (Delta P) Measurement (FIGURE 64)

Operating pressure signal can be taken while the manifold pressure check is taken (using two measuring devices). Or, taken after the manifold pressure measurement is complete.

- 1 - Tee into the negative line between the gas valve and pressure switch and connect to measuring device negative "-".
- 2 - Tee into the positive line between the gas valve and pressure switch and connect to measuring device positive "+".
- 3 - Start unit on low heat (35% rate) and allow 5 minutes for unit to reach steady state.
- 4 - After allowing unit to stabilize for 5 minutes, record operating pressure signal and compare to value given in TABLE 35. Repeat steps 3 on 4 high heat.

MANIFOLD PRESSURE MEASUREMENT

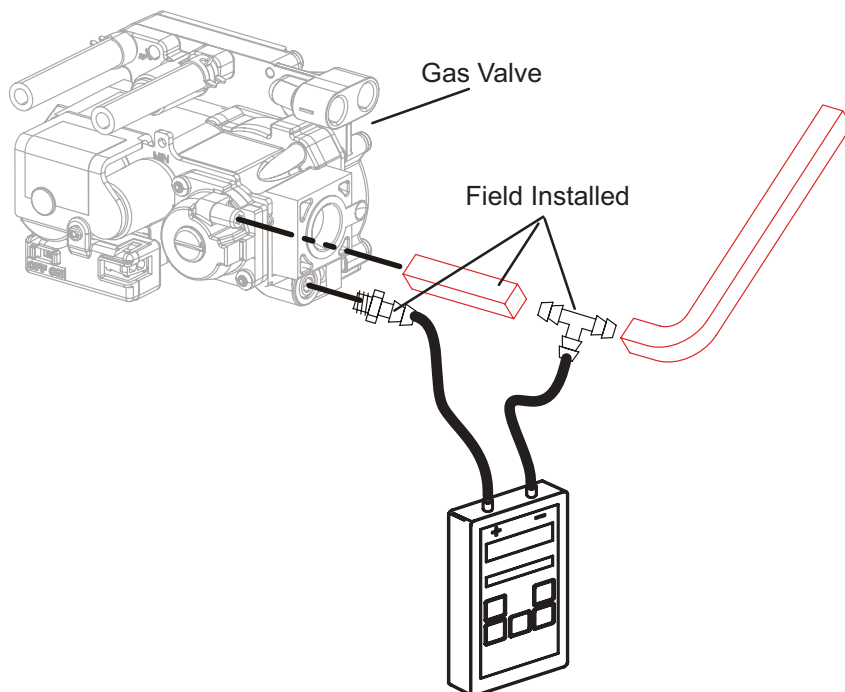

FIGURE 63

Operating Signal (Delta P) Measurement

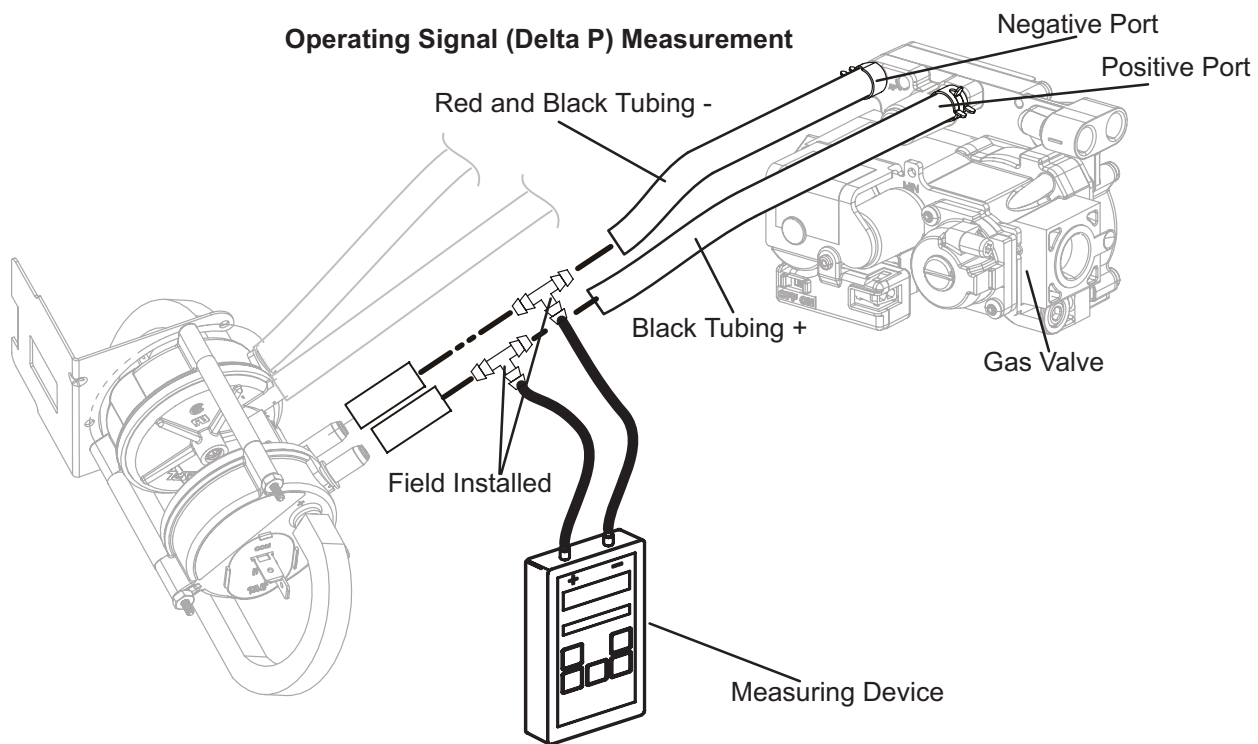

FIGURE 64

TABLE 35

Manifold and Operating Signal Pressures in inches 0 - 7500 ft (0 - 2286 m)

SLP99K Firing Rate	Manifold Pressure Natural Gas		Manifold Pressure LP/Propane		Operating Pressure Signal (Delta P)	
	Min	Max	Min	Max	Min	Max
Low	0.40	0.95	1.2	2.8	0.20	0.40
High	3.0	3.8	9.1	10.5	0.95	1.25
-090-060C Only	Min	Max	Min	Max	Min	Max
Low	0.30	0.85	----	----	0.15	0.35
Low	----	----	1.2	2.8	0.20	0.40
High	3.0	3.8	9.1	10.5	0.95	1.25

NOTE - A natural to LP/propane gas changeover kit is necessary to convert this unit. Refer to the changeover kit installation instruction for the conversion procedure.

Proper Combustion

Furnace should operate a minimum of 15 minutes with correct manifold pressure and gas flow rate before checking combustion. Take combustion sample beyond the flue outlet and compare to the tables below. The maximum carbon monoxide reading should not exceed 100 ppm.

TABLE 36
High Fire

Model Input Size	CO2% Nat	CO2% LP
070	6.5 - 9.0	7.7 - 10.2
090		
110		
135		

TABLE 37
Low Fire

Model Input Size	CO2% Nat	CO2% LP
070	4.7 - 7.2	5.7 - 8.2
090		
110		
135		

High Altitude Information

NOTE - In Canada, certification for installations at elevations over 4500 feet (1372 m) is the jurisdiction of local authorities. SLP99UHVK units require no manifold pressure adjustments for operation at altitudes up to 10,000 feet (3048 m) above sea level. Units installed at altitude of 7,501 to 10,000 feet (2287 to 3048m) require a pressure switch change and conversion kit. See TABLE 38.

The combustion air pressure switch is factory-set and requires no adjustment.

Other Unit Adjustments

Primary Limit

The primary limit is located on the heating compartment vestibule panel. This limit is factory set and require no adjustment.

TABLE 38

Conversion Kit & High Altitude Requirements

Model Input	LP/Propane Conversion Kit		Natural Burner Kit
	0 - 4500 ft (0 - 1372m)	4501 - 10,000 ft (1372 3048m)	4501 - 10,000 ft (1372 3048m)
070	65W77	65W77	Not Required
090XV36C/48C			
090XV60C	20A26	20A88	20A89
110	65W77	65W77	Not Required
135			
Model Input	High Altitude Pressure Switch		
	0 - 7500 ft (0 - 2286m)	7501 - 10,000 ft (2286 - 3048m)	
070	Not Required	14T65	
090XV36C/48C		20A87	
090XV60C		14T65	
110			
135			

Flame Sensor

A flame sensor is located on the left side of the burner support. The sensor is mounted on the flame rollout plate and the tip protrudes into the flame envelope of the left-most burner. The sensor can be removed for service without removing any part of the burners. During operation, flame is sensed by current passed through the flame and sensing electrode. The control allows the gas valve to remain open as long as flame signal is sensed. To check flame sense signal use the push-button found on the integrated control and go to Field Test Mode. The menu will display the flame signal. TABLE 39 shows the flame signal.

TABLE 39

Flame Signal in Microamps

Normal	Low	Drop Out
2.6 or greater	2.5 or less	1.1

NOTE - A much higher than normal micro amp reading (15 for example) may appear when checking flame signal.

Flame Rollout Switches (Two)

These manually reset switches are located on the inside of the burner box. If tripped, check for adequate combustion air before resetting.

Pressure Switches (Two)

The pressure switches are located on the cold end header box. These switches check for proper combustion air inducer operation before allowing ignition trial. The switches are factory-set and require no adjustment. Pressure switch tubing installation is critical for safe operation. See FIGURE 65.

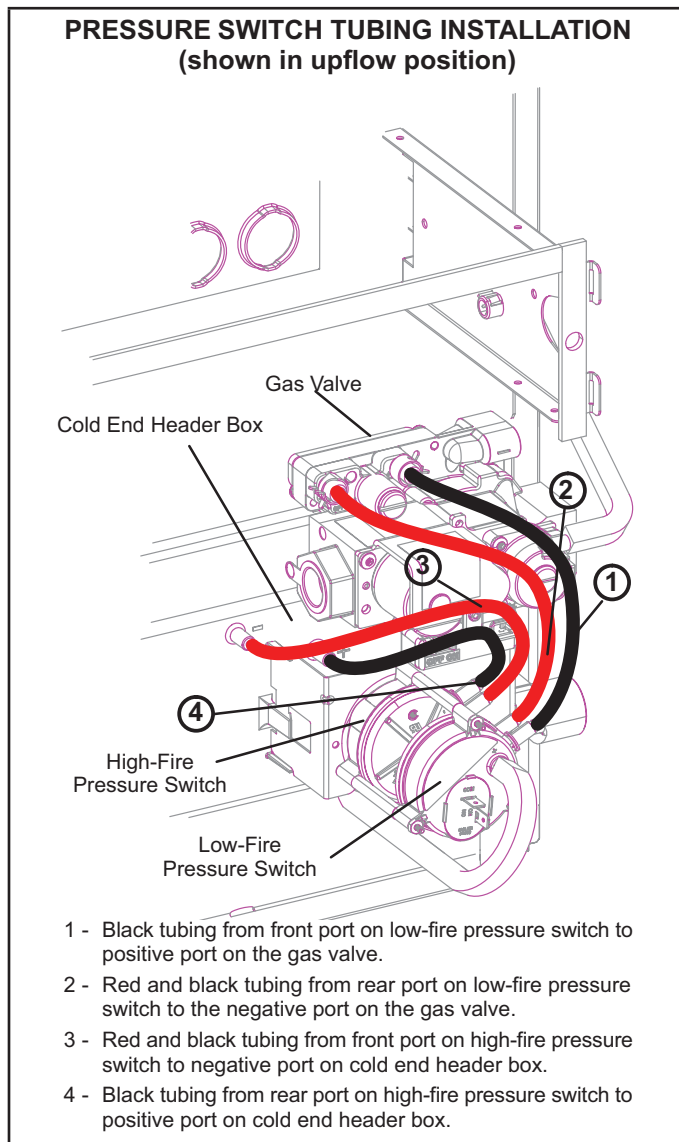

FIGURE 65

Temperature Rise

After the furnace has been started and supply and return air temperatures have been allowed to stabilize, check the temperature rise with the unit operating at 100 percent firing rate. See "Duct System" on page 10 for installing the optional discharge air sensor (shipped with the furnace) used to measure temperature rise. If necessary, adjust the blower speed to maintain the temperature rise within the range shown on the unit nameplate. See TABLE 30 TABLE 30 on page 59 for allowable heating speeds. Increase the blower speed to decrease the temperature rise. Decrease the blower speed to increase the temperature rise. Failure to adjust the temperature rise may cause erratic limit operation.

Electronic Ignition

The integrated control has an added feature of an internal Watchguard control. The feature serves as an automatic reset device for ignition control lockout caused by ignition failure. This type of lockout is usually due to low gas line pressure. After one hour of continuous thermostat demand for heat, the Watchguard will break and remake thermostat demand to the furnace and automatically reset the control to begin the ignition sequence.

Exhaust and Air Intake Pipe

- 1 - Check exhaust and air intake connections for tightness and to make sure there is no blockage.
- 2 - Are pressure switches closed? Obstructed exhaust pipe will cause unit to shut off at pressure switches. Check termination for blockages.
- 3 - Reset manual flame rollout switches on burner box cover.

Heating Sequence of Operation

The integrated control initiates a pressure switch calibration at the initial unit start-up on a call for heat. The ignition control will also initiate a calibration any time main power is turned off and back on and a heating demand is present. Additional calibrations may be initiated by the service technician during field test sequence. The following heating sequence of operation assumes completion of a successful calibration.

NOTE - In communicating applications, the sequence of operation is the same but all DIP switch settings are overridden by the thermostat.

NOTE - The thermostat selection DIP switch on the integrated control is factory-set in the "TWO-STAGE" position.

Applications Using a Two-Stage Thermostat

A - Heating Sequence -- Control Thermostat Selection DIP switch in "Two-Stage" Position (Factory Setting)

- 1 - On a call for heat, thermostat first-stage contacts close sending a signal to the integrated control. The integrated control runs a self-diagnostic program and checks high temperature limit switches for normally closed contacts and pressure switches for normally open contacts. The combustion air inducer is energized at ignition speed, which is approximately the same as the inducer speed at 70 percent firing rate.
- 2 - Once the control receives a signal that the low-fire pressure switch has closed, the combustion air inducer begins a 15-second pre-purge in the ignition speed.
- 3 - After the pre-purge is complete, a 20-second initial ignitor warm-up period begins. The combustion air inducer continues to operate at the ignition speed.
- 4 - After the 20-second warm-up period has ended, the gas valve is energized and ignition occurs. At the same time, the control module sends a signal to begin an indoor blower 30-second ON-delay. When the delay ends, the indoor blower motor is energized at a speed that matches the firing rate. After the 10-second ignition stabilization delay expires, the

inducer speed is adjusted to the appropriate target rate. The inducer will remain at the 70 percent speed as long as the thermostat has a first-stage heating demand.

- 5 - If second-stage heat is required, the thermostat second-stage heat contacts close and send a signal to the integrated control. The integrated control initiates a 30-second second-stage recognition delay.
- 6 - At the end of the recognition delay and on all subsequent calls for heat in the same heating cycle, the integrated control energizes the combustion air inducer at high speed. The control also checks the high-fire pressure switch to make sure it is closed. As the inducer speed is increased to high, the indoor blower motor is adjusted to a speed which is appropriate for the target rate.
- 7 - When the demand for high-fire (second stage) heat is satisfied, the gas valve is de-energized and the field selected indoor blower off delay begins. The combustion air inducer begins a 20-second post-purge period.
- 8 - When the combustion air post-purge period is complete, the inducer is de-energized. The indoor blower is de-energized at the end of the off delay.

Applications Using a Two-Stage Thermostat

B - Heating Sequence -- Control Thermostat Selection DIP switch in "Variable Capacity" Position

- 1 - On a call for heat, thermostat first-stage contacts close sending a signal to the integrated control. The integrated control runs a self-diagnostic program and checks high temperature limit switches for normally closed contacts and pressure switches for normally open contacts. The combustion air inducer is energized at ignition speed, which is approximately the same as the inducer speed at 70 percent firing rate.
- 2 - Once the control receives a signal that the low-fire pressure switch has closed, the combustion air inducer begins a 15-second pre-purge in low speed.
- 3 - After the pre-purge is complete, a 20-second initial ignitor warm-up period begins. The combustion air inducer continues to operate at the ignition speed.
- 4 - After the 20-second warm-up period has ended, the gas valve is energized and ignition occurs. At the same time, the control module begins an indoor blower 30-second ON-delay. When the delay ends, the indoor blower motor is energized at a speed that matches the firing rate. After the 10-second ignition stabilization delay expires, the inducer speed is adjusted to the appropriate target rate. If the furnace is operating in the initial heating cycle after power-up, the initial firing rate will be approximately 35 percent. The firing rate on subsequent cycles will be automatically adjusted by the integrated control based on thermostat cycles. The firing rate will vary and will range from 35 percent to 90 percent. The furnace will continue this operation as long as the thermostat has a first-stage heating demand.

- 5 - If second-stage heat is required, the thermostat second-stage heat contacts close and send a signal to the integrated control. The integrated control either increases the firing rate to 70 percent (if the current rate is at or below 60 percent) or increases the firing rate by 10 percent (if the current rate is above 60 percent). If the call for heat continues 5 minutes beyond this initial upstage, the rate will be increased by 10 percent every 5 minutes until the call for heat is satisfied or the furnace reaches 100 percent rate. As the firing rate increases, the indoor blower motor is adjusted to a speed which is appropriate for the target rate.
- 6 - If second-stage heat demand is satisfied, but first stage is still present, the furnace will continue to operate at the present firing rate until the heat cycle ends.
- 7 - When the demand for first- and second-stage heat is satisfied, the gas valve is de-energized and the field selected indoor blower off delay begins. The combustion air inducer begins a 20-second post-purge period.
- 8 - When the combustion air post-purge period is complete, the inducer is de-energized. The indoor blower is de-energized at the end of the off delay.

Applications Using A Single-Stage Thermostat

C - Heating Sequence -- Control Thermostat Selection DIP switch in "Single-Stage" Position

- 1 - On a call for heat, thermostat first-stage contacts close sending a signal to the integrated control. The integrated control runs a self-diagnostic program and checks high temperature limit switches for normally closed contacts and pressure switches for normally open contacts. The combustion air inducer is energized at the ignition speed, which is approximately the same as the inducer speed at 70 percent firing rate.
- 2 - Once the control receives a signal that the low-fire pressure switch has closed, the combustion air inducer begins a 15-second pre-purge at the ignition speed.
- 3 - After the pre-purge is complete, a 20-second initial ignitor warm-up period begins. The combustion air inducer continues to operate at the ignition speed.
- 4 - After the 20-second warm-up period has ended, the gas valve is energized and ignition occurs, which initiates a 10-second ignition stabilization delay. At the same time, the control module sends a signal to begin an indoor blower 30-second ON-delay. When the delay ends, the indoor blower motor is energized at a speed which is appropriate for the firing rate. After the 10-second ignition stabilization delay expires, the inducer speed is adjusted to 35 percent speed. The integrated control also initiates a second-stage on delay (factory-set at 7 minutes; adjustable to 12 minutes).
- 5 - If the heating demand continues beyond the second-stage on delay, the integrated control energizes the combustion air inducer at 70 percent speed. The indoor blower motor is adjusted to a speed which matches the target rate. A fixed, 10-minute third-stage on delay is initiated.

- 6 - If the heating demand continues beyond the third-stage on delay, the integrated control energizes the inducer at high speed. The indoor blower motor is adjusted to a speed which is appropriate for the target rate.
- 7 - When the thermostat heating demand is satisfied, the gas valve is de-energized and the combustion air inducer begins a 20-second post-purge. The field-selected indoor blower off delay begins.
- 8 - When the combustion air post-purge period is complete, the inducer is de-energized. The indoor blower is de-energized at the end of the off delay.

Service

WARNING

**ELECTRICAL SHOCK, FIRE,
OR EXPLOSION HAZARD.**

Failure to follow safety warnings exactly could result in dangerous operation, serious injury, death or property damage.

Improper servicing could result in dangerous operation, serious injury, death, or property damage.

Before servicing, disconnect all electrical power to furnace.

When servicing controls, label all wires prior to disconnecting.

Take care to reconnect wires correctly.

Verify proper operation after servicing.

WARNING

The blower access panel must be securely in place when the blower and burners are operating. Gas fumes, which could contain carbon monoxide, can be drawn into living space resulting in personal injury or death.

Annual Furnace Maintenance

At the beginning of each heating season, and to comply with the Lennox Limited Warranty, your system should be checked as follows:

- 1 - Check wiring for loose connections, voltage at indoor unit and amperage of indoor motor.
- 2 - Check the condition of the belt and shaft bearings if applicable.
- 3 - Inspect all gas pipe and connections for leaks.
- 4 - Check the cleanliness of filters and change if necessary (monthly).
- 5 - Check the condition and cleanliness of burners and heat exchanger and clean if necessary.

- 6 - Check the cleanliness of blower assembly and clean the housing, blower wheel and blower motor if necessary.
- 7 - Inspect the condensate drain and trap for leaks and cracks. The drain and trap must also be cleaned and the trap must be primed with water. Inspect the rubber hoses connected to the pressure switches for cracks or loose connections, replace as necessary. Remove the rubber hoses from the cold end header box and inspect for any blockage, clean as needed. If strainers are installed in the hoses remember to remove and clean before reinstalling the hoses.
- 8 - Evaluate the heat exchanger integrity by inspecting the heat exchanger per the AHRI heat exchanger inspection procedure. This procedure can be viewed at www.ahrinet.org
- 9 - Ensure sufficient combustion air is available to the furnace. Fresh air grilles and louvers (on the unit and in the room where the furnace is installed) must be properly sized, open and unobstructed to provide combustion air.
- 10 - On condensing furnaces, inspect the furnace intake and exhaust pipes to make sure they are in place, structurally sound, without holes, blockage or leakage and the exhaust pipe is sloped toward the furnace. Inspect terminations to ensure they are free of obstructions and are structurally sound. Inspect the furnace return air duct connection to ensure the duct is sealed to the furnace. Check for air leaks on supply and return ducts and seal where necessary.
- 11 - Inspect the furnace return air duct connection to ensure the duct is sealed to the furnace. Check for air leaks on supply and return ducts and seal where necessary.
- 12 - Check the condition of the furnace cabinet insulation and repair if necessary.
- 13 - Perform a complete combustion analysis during the furnace inspection to ensure proper combustion and operation. Consult Service Literature for proper combustion values.
- 14 - Verify operation of CO detectors and replace batteries as required.
- 15 - Inspect the Low GWP sensor / sensors and rubber sleeve

Perform a general system test. Turn on the furnace to check operating functions such as the start-up and shut-off operation.

- 1 - Check the operation of the ignition system, inspect and clean flame sensor. Check microamps before and after. Check controls and safety devices (gas valve, flame sensor, temperature limits). Consult Service Manual for proper operating range. Thermal Limits should be checked by restricting airflow and not disconnecting the indoor blower. For additional details, please see Service and Application Note H049.

- 2 - Verify that system total static pressure and airflow settings are within specific operating parameters.
- 3 - Clock gas meter to ensure that the unit is operating at the specified firing rate for each stage of operation. Check supply, manifold and signal pressures at 35, 70 and 100% capacity as outlined in the unit Service Literature. If manifold pressure adjustment is necessary, consult the Service Literature for unit specific information on adjusting gas pressure. Not all gas valves are adjustable. Verify correct temperature rise.

NOTE - After any heavy snow, ice or frozen fog event the furnace vent pipes may become restricted. Always check the vent system and remove any snow or ice that may be obstructing the plastic intake or exhaust pipes.

Winterizing and Condensate Trap Care

- 1 - Turn off power to the unit.
- 2 - Have a shallow pan ready to empty condensate water.
- 3 - Remove the drain plug from the condensate trap and empty water. Inspect the trap then reinstall the drain plug and refill trap with water.

Cleaning the Burner Assembly

- 1 - Turn off electrical and gas power supplies to furnace. Remove upper and lower furnace access panels.
- 2 - Disconnect the 2-pin plug from the gas valve.
- 3 - Remove the burner box cover.
- 4 - Disconnect the gas supply line from the gas valve. Remove gas valve/manifold assembly.

- 5 - Mark and disconnect sensor wire from the sensor. Disconnect wires from flame rollout switches.
- 6 - Remove four screws which secure burner box assembly to vent panel. Remove burner box from the unit.
- 7 - Use the soft brush attachment on a vacuum cleaner to gently clean the face of the burners. Visually inspect the inside of the burners and crossovers for any blockage caused by foreign matter. Remove any blockage.
- 8 - Reinstall the burner box assembly using the existing four screws. Make sure that the burners line up in the center of the burner ports.
- 9 - Reconnect the sensor wire and reconnect the 2-pin plug to the ignitor wiring harness. Reconnect wires to flame rollout switches.
- 10 - Reinstall the gas valve manifold assembly. Reconnect the gas supply line to the gas valve. Reinstall the burner box cover.
- 11 - Reconnect 2-pin plug to gas valve.
- 12 - Replace the blower compartment access panel.
- 13 - Refer to instruction on verifying gas and electrical connections when re-establishing supplies.
- 14 - Follow lighting instructions to light and operate furnace for 5 minutes to ensure that heat exchanger is clean and dry and that furnace is operating properly.
- 15 - Replace heating compartment access panel.

Repair Parts List

The following repair parts are available through Lennox dealers. When ordering parts, include the complete furnace model number listed on the nameplate -- Example: SLP99UH070XV36BK. All service must be performed by a licensed professional installer (or equivalent), service agency, or gas supplier.

Cabinet Parts

- Outer access panel
- Blower access panel
- Top cap

Control Panel Parts

- Transformer
- Integrated control
- Door interlock switch
- Circuit breaker

Blower Parts

- Blower wheel
- Motor
- Motor mounting frame
- Blower housing cut-off plate
- Power choke (1HP only)

Heating Parts

- Flame sensor
- Heat exchanger assembly
- Gas manifold
- Combustion air inducer
- Gas valve
- Main burner cluster
- Main burner orifices
- Pressure switches
- Ignitor
- Primary limit control
- Flame rollout switches

Refrigerant Detection System Parts

- Refrigerant Detection Sensor
- Refrigerant Line Set Sleeve

Configuring Unit Size Codes

Power-Up - Number displayed represents by integrated control unit size code (furnace model and capacity). If three horizontal bars are displayed followed by continuous E203, furnace control does not recognize **unit size code**. Configure per the following:

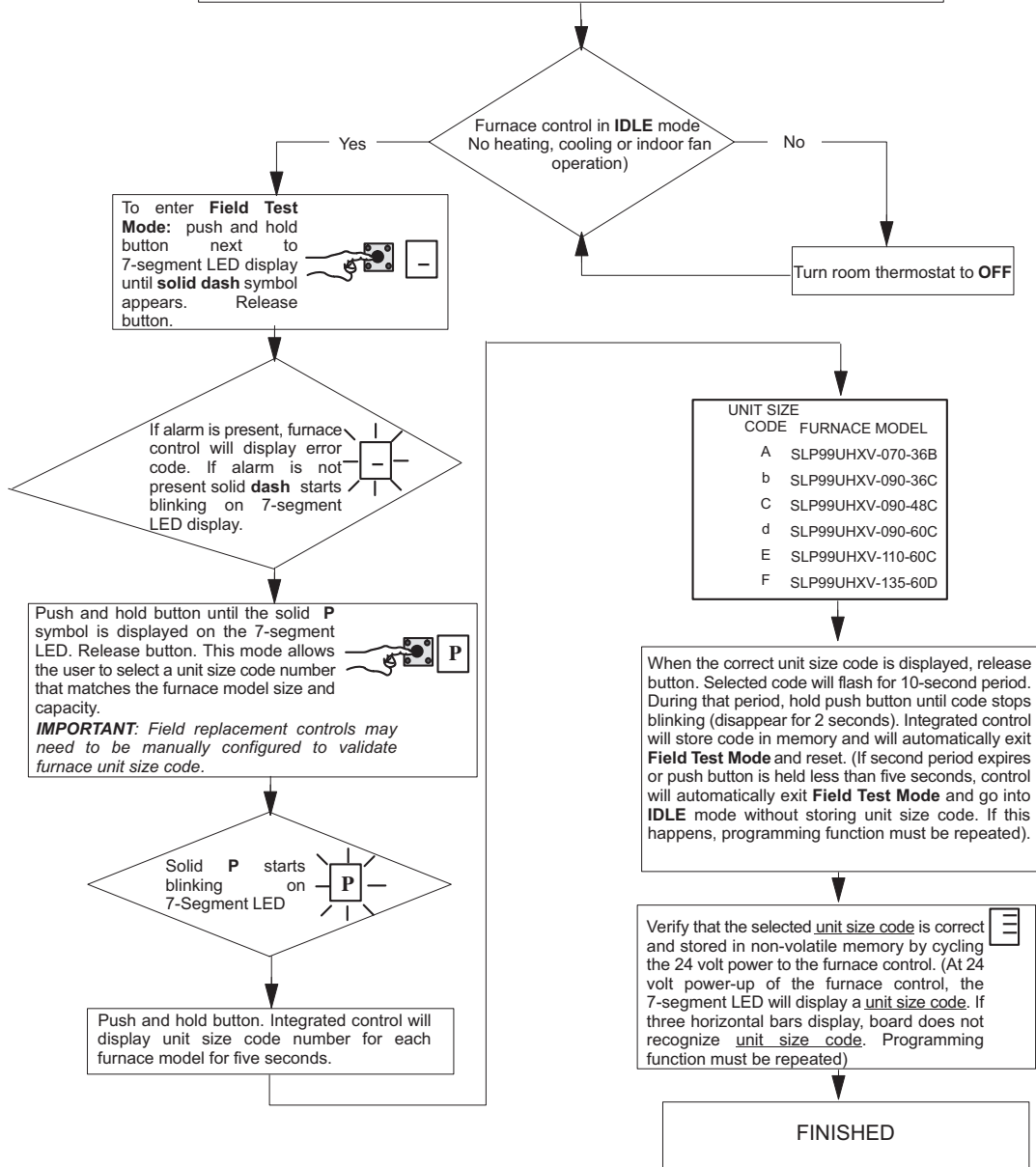

CALL FOR HIGH FIRE WITH TWO-STAGE THERMOSTAT

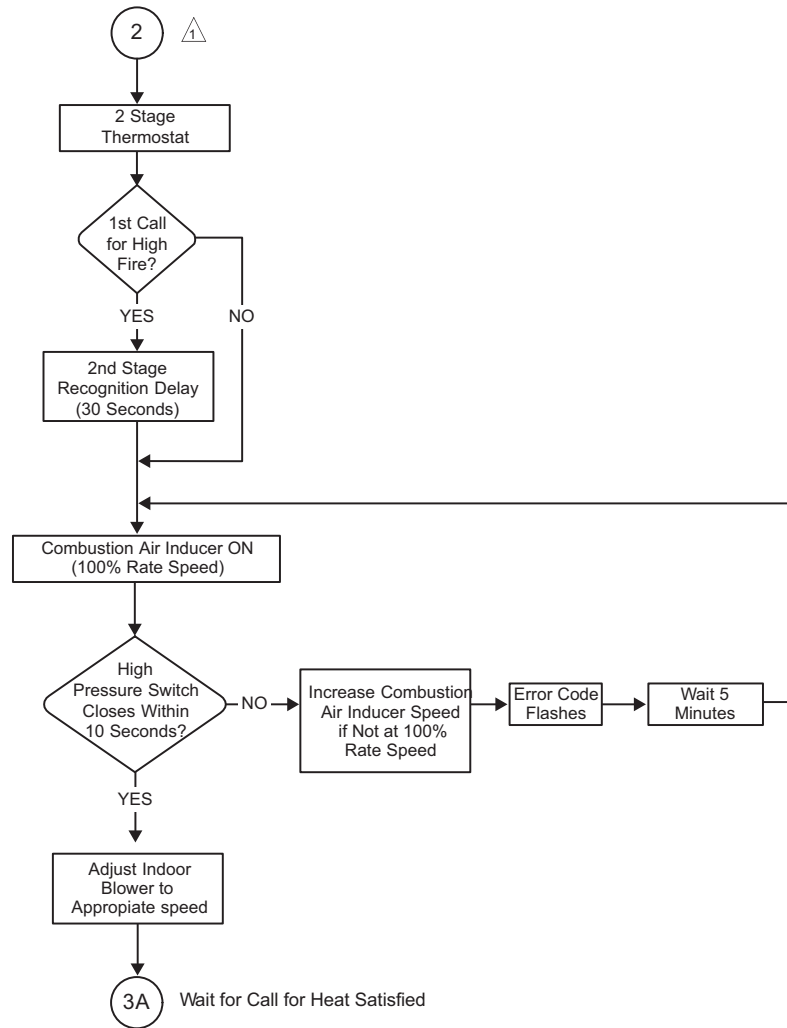

⚠️ System will always light at 70% even if 2nd stage call for heat is in place

⚠️ If the high pressure switch does not close within 5 attempts, the system will operate at low fire for the remainder of the call for heat at request

CALL FOR HIGH FIRE WITH TWO-STAGE THERMOSTAT

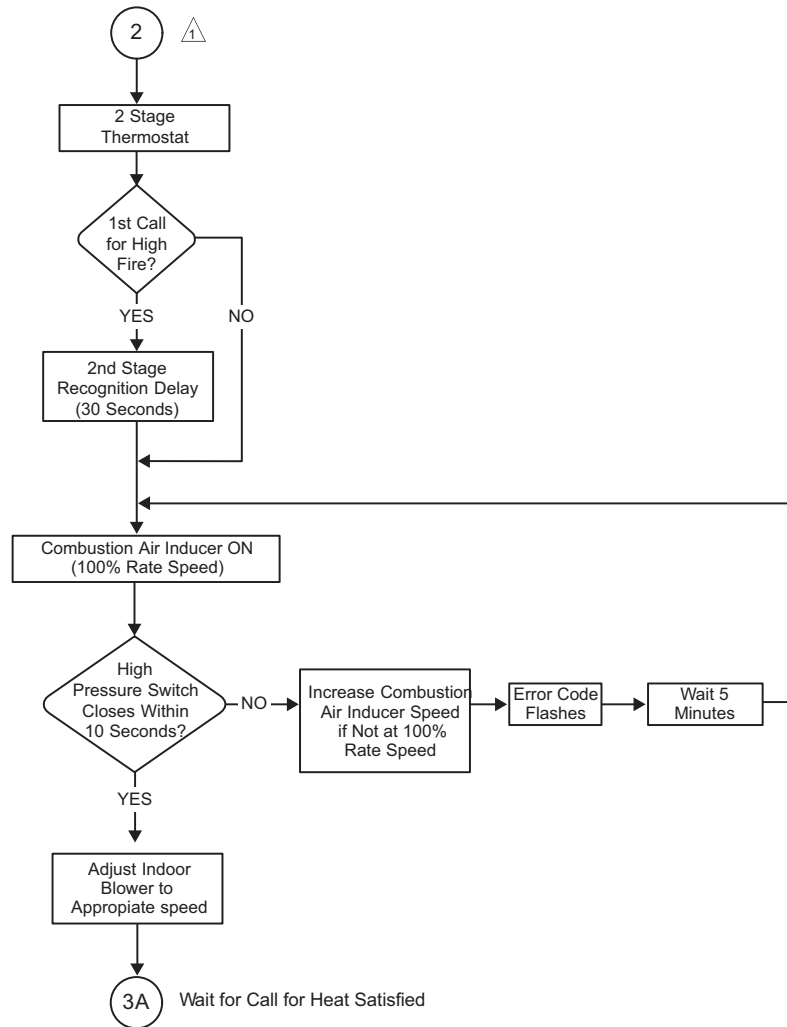

⚠️ System will always light at 70% even if 2nd stage call for heat is in place

⚠️ If the high pressure switch does not close within 5 attempts, the system will operate at low fire for the remainder of the call for heat at request

IGNITION AND CALL FOR HEAT WITH SINGLE-STAGE THERMOSTAT

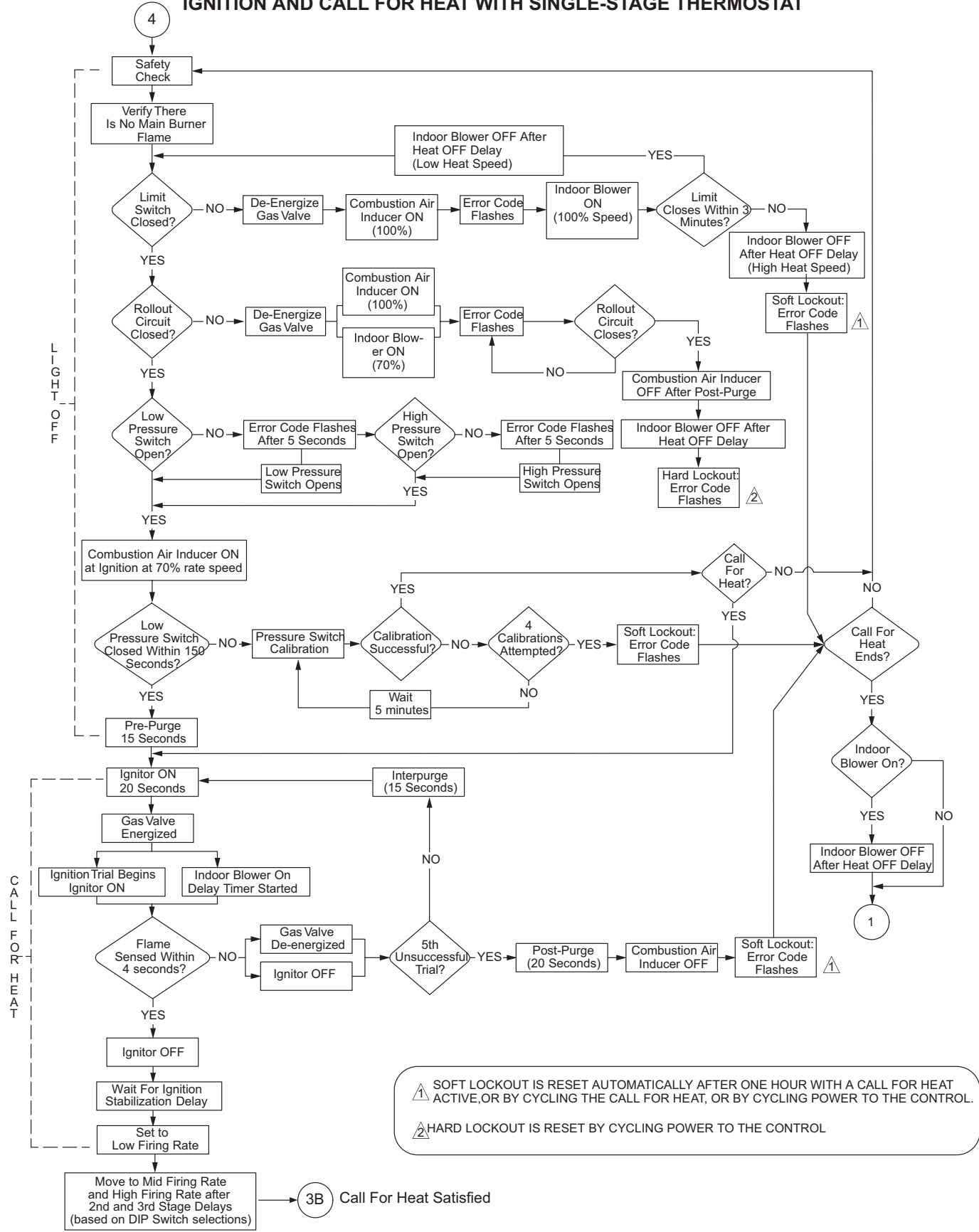

CALL FOR COOLING

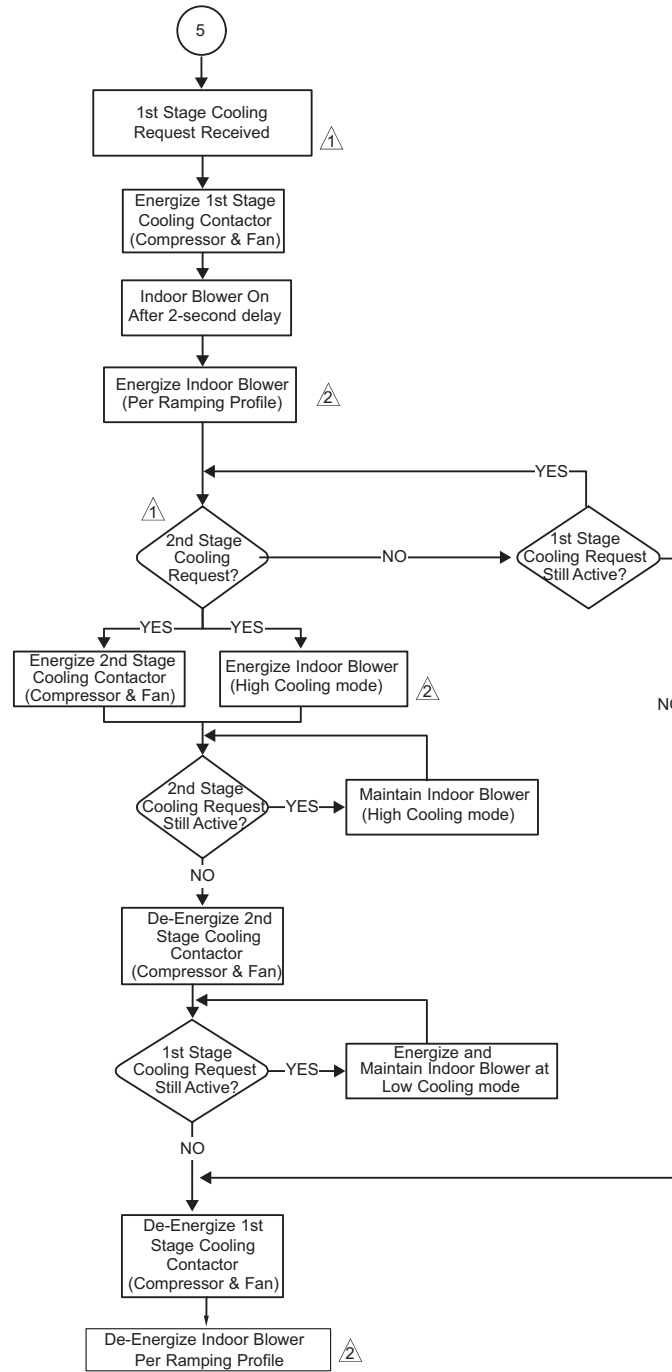

1 2nd stage cooling operation requires a 2-stage thermostat, a 2-stage cooling system and on-board link W915 must be cut. The control will not respond to a 2nd stage cooling request unless a 1st stage cooling request is active

2 Indoor blower cooling mode and high cooling mode have a specific ON, OFF and speed ramping profiles. The specific profile is selected using the DIP switches on the control.

CONTINUOUS LOW SPEED INDOOR BLOWER SEQUENCE OF OPERATION

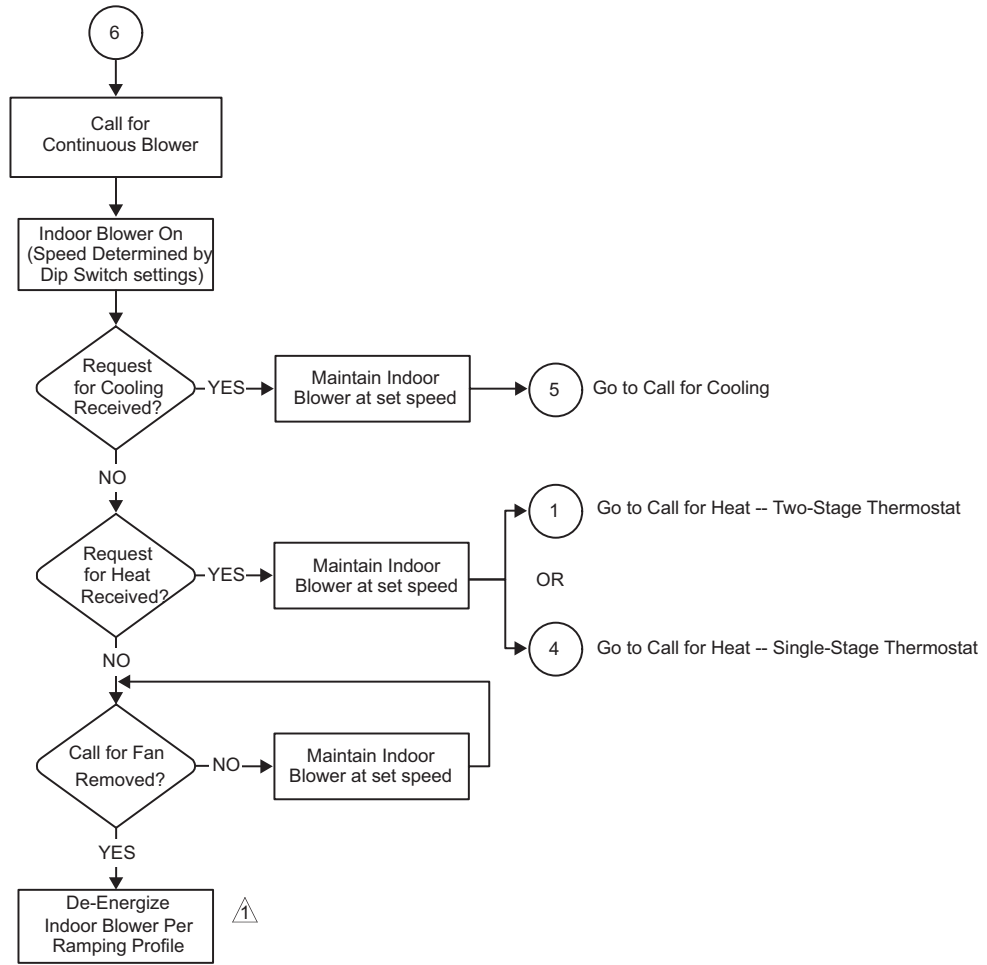

⚠ Indoor blower low cooling mode and high cooling mode, have specific ON - OFF and speed ramping profiles. The specific profile is selected using the dip switches on the control.

Requirements for Commonwealth of Massachusetts

Modifications to NFPA-54, Chapter 10

Revise NFPA-54 section 10.8.3 to add the following requirements:

For all side wall, horizontally vented, gas-fueled equipment installed in every dwelling, building or structure used in whole or in part for residential purposes, including those owned or operated by the Commonwealth and where the side wall exhaust vent termination is less than seven (7) feet above the finished grade in the area of the venting, including but not limited to decks and porches, the following Requirements shall be satisfied:

- 1 - **INSTALLATION OF CARBON MONOXIDE DETECTORS.** At the time of installation of the side wall, horizontally vented, gas-fueled equipment, the installing plumber or gas fitter shall observe that a hard-wired carbon monoxide detector with an alarm and battery backup is installed on the floor level where the gas equipment is to be installed. In addition, the installing plumber or gasfitter shall observe that a battery-operated or hard-wired carbon monoxide detector with an alarm is installed on each additional level of the dwelling, building or structure served by the side wall, horizontally vented, gas-fueled equipment. It shall be the responsibility of the property owner to secure the services of qualified licensed professionals for the installation of hard-wired carbon monoxide detectors.
 - a. In the event that the side wall, horizontally vented, gas-fueled equipment is installed in a crawl space or an attic, the hard-wired carbon monoxide detector with alarm and battery back-up may be installed on the next adjacent floor level.
 - b. In the event that the requirements of this subdivision cannot be met at the time of completion of installation, the owner shall have a period of thirty (30) days to comply with the above requirements; provided, however, that during said thirty (30) day period, a battery-operated carbon monoxide detector with an alarm shall be installed.
- 2 - **APPROVED CARBON MONOXIDE DETECTORS.** Each carbon monoxide detector as required in accordance with the above provisions shall comply with NFPA 720 and be ANSI/UL 2034 listed and IAS certified.
- 3 - **SIGNAGE.** A metal or plastic identification plate shall be permanently mounted to the exterior of the building at a minimum height of eight (8) feet above grade directly in line with the exhaust vent terminal for the horizontally vented, gas-fueled heating appliance or equipment. The sign shall read, in print size no less than one-half (1/2) inch in size, "GAS VENT DIRECTLY BELOW. KEEP CLEAR OF ALL OBSTRUCTIONS."

- 4 - **INSPECTION.** The state or local gas inspector of the side wall, horizontally vented, gas-fueled equipment shall not approve the installation unless, upon inspection, the inspector observes carbon monoxide detectors and signage installed in accordance with the provisions of 248 CMR 5.08(2)(a) 1 through 4.

EXEMPTIONS: The following equipment is exempt from 24 CMR 5.08(2)(a) 1 through 4:

- 1 - The equipment listed in Chapter 10 entitled "Equipment Not Required to Be Vented" in the most current edition of NFPA 54 as adopted by the Board; and
- 2 - Product Approved side wall, horizontally vented, gasfueled equipment installed in a room or structure separate from the dwelling, building or structure used in whole or in part for residential purposes.

MANUFACTURER REQUIREMENTS - GAS EQUIPMENT VENTING SYSTEM PROVIDED.

When the manufacturer of Product Approved side wall, horizontally vented, gas-fueled equipment provides a venting system design or venting system components with the equipment, the instructions provided by the manufacturer for installation of the equipment and the venting system shall include:

- 1 - Detailed instructions for the installation of the venting system design or the venting system components; and
- 2 - A complete parts list for the venting system design or venting system.

MANUFACTURER REQUIREMENTS - GAS EQUIPMENT VENTING SYSTEM NOT PROVIDED.

When the manufacturer of Product Approved side wall, horizontally vented, gas-fueled equipment does not provide the parts for venting the flue gases, but identifies "special venting systems," the following requirements shall be satisfied by the manufacturer:

- 1 - The referenced "special venting system" instructions shall be included with the appliance or equipment installation instructions; and
- 2 - The "special venting systems" shall be Product Approved by the Board, and the instructions for that system shall include a parts list and detailed installation instructions.

A copy of all installation instructions for all Product Approved side wall, horizontally vented, gas-fueled equipment, all venting instructions, all parts lists for venting instructions, and/or all venting design instructions shall remain with the appliance

FOR THE PROVINCE OF ONTARIO, HORIZONTAL SIDEWALL VENT APPLICATIONS ONLY

For exterior horizontal venting applications, the 2" X 1.5" reducer for 2" venting at the point where the exhaust pipe exits the structure is not required in direct or nondirect vent applications in the Province of Ontario. In these applications, the vent should be oriented such that the exhaust plume is unobjectionable. If the installation requires more separation between the flue gases and the building structure, a reducer may be installed on the exhaust pipe to increase the flue gas velocity.

ADDENDUM FOR ALL PROVINCES OF CANADA

See below for venting for all provinces of Canada. Lennox approves the following termination for use in all provinces of Canada.

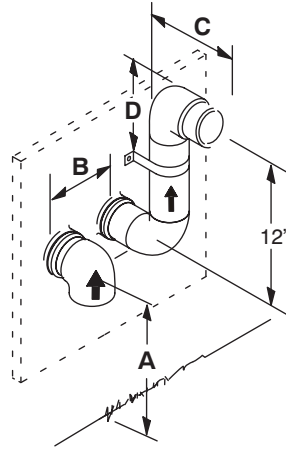

	2" (51MM) Vent Pipe	3" (76MM) Vent Pipe
A – Clearance above grade or average snow accumulation	12" (305 mm) Min.	12" (305 mm) Min.
B – Horizontal separation between intake and exhaust	6" (152 mm) Min. 24" (610 mm) Max.	6" (152 mm) Min. 24" (610 mm) Max.
C – Exhaust pipe length	Per: Saskatchewan Code of Practice	
D – Wall support distance from top of each pipe (intake/exhaust)	6" (152 mm) Max.	6" (152 mm) Max.

NOTE – Flue gas may be acidic and may adversely affect some building materials. If flue gases impinge on the building materials, a corrosion-resistant shield should be used to protect the wall surface. The shield should be constructed using wood, sheet metal or other suitable material. All seams, joints, cracks, etc. in affected area, should be sealed using an appropriate sealant.