



Lennox[®] S40 Smart Thermostat

Installation and Setup Guide

508222-03 02/2026
Supersedes 12/2025
Copyright 2026[®]
Lennox Industries Inc.
Dallas, Texas, USA



508222-03

Table of Contents

Shipping and Packing List	4	<i>Customization Process</i>	21	<i>Displaying the Outdoor Sensor Temperature on the Home Screen</i>	48
Thermostat External Components	4	<i>Setup Through the Thermostat</i>	21	<i>Displaying the Indoor Humidity on the Home Screen</i>	49
<i>External Component Locations</i>	4	<i>Setup Through the Mobile App</i>	22	Specific Configurations	49
<i>Reboot Button, Micro USB Connection and Built-in Sensors</i>	4	<i>Login with my Lennox Pros Account</i>	22	<i>Dehumidification Settings</i>	49
Lennox® Smart Applications	4	<i>Continue Without a Lennox Pros Account</i>	25	<i>Dehumidification Setting Options</i>	49
<i>Lennox® Home App (Homeowner)</i>	4	Helping the Homeowner Connect		<i>Overcooling</i>	49
<i>Lennox® Smart Technician App (Installer)</i>	4	Thermostat to Home Wi-Fi	28	<i>Dehumidification Set Point</i>	49
<i>Download Lennox® Smart Applications</i>	5	<i>Home Wi-Fi Access Point is Visible</i>	28	<i>Advanced Dehumidification Descriptions</i>	49
<i>Lennox® Smart Technician App</i>	5	<i>Home Wi-Fi Access Point is Hidden</i>	29	Lennox Smart Zoning	50
<i>Lennox® Home App</i>	5	<i>Wi-Fi Terminology</i>	29	PureAir S	50
<i>Additional Support</i>	5	<i>Received Signal Strength Indication (RSSI)</i>	30	Ventilation (ERV, HRV and Fresh Air Damper)	50
Service and Support - Service Access and Remote In	5	Service Center	30	<i>Ventilation Rates</i>	51
Thermostat Dimensions	6	<i>Notifications</i>	30	<i>Energy Recovery Ventilator (ERV)</i>	51
Thermostat Terminal Information	6	<i>Equipment Settings</i>	30	<i>Heat Recovery Ventilator (HRV)</i>	51
Wiring Diagrams	6	<i>Thermostat</i>	31	<i>Fresh Air Damper</i>	51
<i>Communication Wiring Options</i>	6	<i>Air Handler</i>	41	<i>Zoning Application</i>	51
<i>Minimizing Electrical Noise</i>	8	<i>Furnace</i>	42	<i>Operation of Fresh Air Dampers with Environmental Overrides</i>	51
<i>Application Specific Wiring Diagrams</i>	8	<i>Heat Pump</i>	43	<i>Ventilation Control Modes</i>	51
<i>Dual Fuel and Ventilation Diagrams</i>	16	<i>Air Conditioner</i>	45	Notifications (Service and Alert Codes)	53
Installation Considerations	16	<i>Zoning Control</i>	46	<i>Alert Code Priority Types and Notification Options</i>	53
Thermostat Installation	17	<i>PureAir S</i>	46	<i>Soft Disable</i>	54
<i>Installation</i>	17	<i>Add/Remove Equipment</i>	46	<i>Possible Cause</i>	54
<i>Installing Thermostat to Sub-Base</i>	18	<i>Add Device</i>	46	<i>Re-Configure System</i>	54
Commissioning using the Lennox® Smart Technician	18	<i>Smart Devices Network</i>	46	<i>Service Notification Alert Codes</i>	54
<i>Mobile Device Operating System Requirements</i>	18	<i>Managing Smart Devices</i>	46	<i>Alert Codes</i>	55
<i>Establishing a Direct Wireless Connection to the Thermostat</i>	19	<i>Lennox Smart Room Sensor</i>	47	Installation Checklist	105
<i>Commissioning Screens</i>	19	<i>Lennox Smart Air Quality Monitor</i>	47	Technical Support and Mobile App for Installers/Technicians Only	106
Servicing using the Lennox® Smart Technician App	20	<i>Lennox Wireless Extender</i>	47	Technical Support for Installers/Technicians Only	106
Multiple Thermostats - Group ID	20	<i>Reset</i>	47	<i>Lennox Smart Technician App for Installers/Technicians Only</i>	106
Automatic Configuration of Existing Equipment ..	20	Information	47	<i>LennoxPros Mobile Application for Installers/Technicians Only</i>	106
Setup and Customization Process	21	Tests	48		
<i>Setup Process</i>	21	Diagnostics	48		
		Installation Report	48		
		<i>Connect to Lennox® Smart Technician App</i>	48		
		Displaying Outdoor Temperature (Sensor) and Indoor Humidity on the Thermostat Home Screen	48		

LennoxPros Service Dashboard	106
<i>Service Dashboard Search Screen.....</i>	<i>106</i>
<i>Customer Search Results.....</i>	<i>106</i>
<i>Home Systems.....</i>	<i>107</i>
<i>System History.....</i>	<i>107</i>
<i>Temporary Advanced Diagnostics Access (Remote In Button).....</i>	<i>107</i>
<i>Alerts & Reminders: [System Name].....</i>	<i>107</i>
<i>Equipment & Reports.....</i>	<i>107</i>
<i>Equipment Configuration Profile (ECP)</i>	<i>108</i>
<i>Equipment Profiles.....</i>	<i>108</i>
Unregistering the S40 Smart Thermostat.....	109
<i>Unregister System.....</i>	<i>109</i>
<i>Move Out.....</i>	<i>109</i>
<i>Remove Home.....</i>	<i>109</i>
<i>Delete Account.....</i>	<i>109</i>
<i>Factory Reset.....</i>	<i>110</i>
Index	111

Shipping and Packing List

Table 1. Packing List

Quantity	Description
1	Lennox® S40 Smart Thermostat
1	Sub-base
4	Mounting screws (#6 x 1.25 SMS pan head Phillips)
4	Wall anchors (alligator flanged wall anchors)
1	Quick Start guide
1	Warranty certificate

Thermostat External Components

External Component Locations

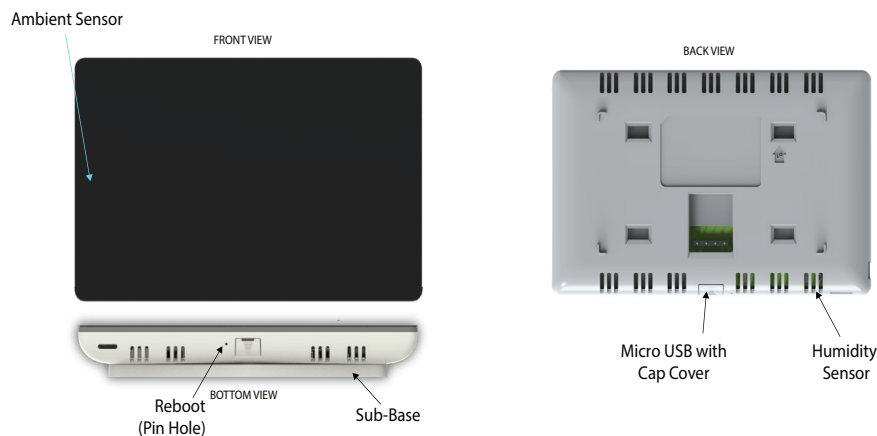

Figure 1. Thermostat External Components

Reboot Button, Micro USB Connection and Built-in Sensors

The following diagrams in this section illustrates the basic Lennox control wiring for all compatible components.

- **Proximity Sensor** - Detects a person approaching the Thermostat. If the Thermostat is in screen saver mode and the proximity sensor setting is set to **ON** (factory default is **OFF**), the proximity sensor takes the Thermostat out of screen saver mode automatically and returns to the home screen when someone approaches. This feature can be disabled by going to **Menu > Setting > Display**.
- **Ambient Sensor** - This sensor determines ambient light levels around the thermostat. If screen brightness is set to **AUTO**, the thermostat will automatically adjust screen brightness based on surrounding room light. To set to **AUTO**, go to **Menu > Settings > Display** and enable **Auto Brightness**.
- **Humidity sensor** - This is the intake location for the built-in humidity sensor. Do not block the intake location. The indoor humidity percentage is displayed (enabled by default) on the home screen. The humidity percentage display on the home screen can be disabled by going to **Menu > Setting > Display**.
- **Temperature Sensor** - This determines the room temperature.
- **Reboot button** - Using a paper clip, press and hold this button for approximately six (6) seconds to reboot the Thermostat. No settings are lost using this procedure.
- **Micro USB connector** with cover - For future use.

Lennox® Smart Applications

Lennox® Home App (Homeowner)

- The free Lennox® Home is available for use on iOS and Android™ devices.
- Controls cooling/heating temperatures, fan operation, set programs (such as Sleep mode and Away mode) for multiple locations.
- Controls individual zone settings if system is equipped with the optional Lennox Zoning Control System.
- Controls PureAir S Air Purification System.
- Controls fresh air dampers and ERV/HRV when using an Equipment Interface Module (EIM).

Lennox® Smart Technician App (Installer)

- The free **Lennox® Smart Technician App** allows the installer to commission and service the system on most iOS and Android™ devices.
- Remotely turn the system on and off during setup.

Download Lennox® Smart Applications

Scan the QR codes listed below to download the specific application you desire.

Lennox® Smart Technician App



Google Play
(Android™)



App Store
(iOS)

Lennox® Home App



Google Play
(Android™)



App Store
(iOS)

Additional Support

The following QR codes are Android™ and iOS compatible.



Dealer Support Pages



Smarter Together Support



Smarter Together Support
(Spanish & French)



Smarter Together - FAQs

Service and Support - Service Access and Remote In

IMPORTANT

Protect homeowner investment and peace of mind with active monitoring of system operations through the Lennox® S40 Smart Thermostat. This feature is free of charge and provides basic maintenance reminders, alerts homeowner of potential issues, and can even allow the homeowner to remotely share diagnostics with the Lennox dealer to troubleshoot and fix problems. This proactive care helps eliminate downtime and avoid unnecessary service visits and repair costs, ensuring nothing short of perfect air.

Please share this information with homeowner as you ask them to accept the Advanced Diagnostics & Remote sharing permissions.

With the homeowner's permission, use the following procedure to enable remote access and diagnostics.

From the thermostat home screen, go to **Menu > Lennox Dealer Support Access > Local Lennox Dealer Info** and verify that all fields are complete. Select **Dealer Support Access** and press the slide buttons to **ON** to enable Remote Sharing, Alerts and Notifications, and Advanced Diagnostics.

- **Remote Sharing** - Enables the local Lennox Dealer to view historical data (system setpoints, cooling and heating run times, etc.) to better diagnose issues, should they occur.
- **Alerts and Notifications** - Notifies the local Lennox Dealer whenever the system requires service or maintenance.
- **Advanced Diagnostics** - Remotely share diagnostics with the local Lennox Dealer to troubleshoot and fix problems. This proactive care helps eliminate downtime and avoid unnecessary service visits and repair costs.

Thermostat Dimensions

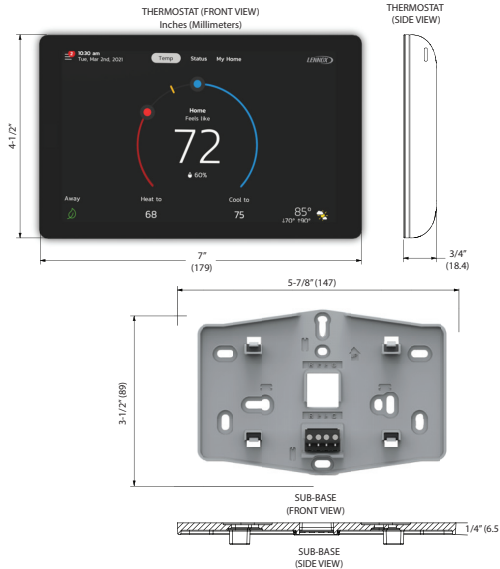

Figure 2. Thermostat and Sub-Base

Thermostat Terminal Information

Table 2. Terminal Designations and Wiring Recommendations

Terminal Designation	Description	Thermostat Wiring
R	24VAC input	18AWG unshielded
I+	RS-BUS I+	18 - 22AWG unshielded or shielded
I-	RS-BUS I-	NOTE: Shielded wiring may be required in some rare situations. Use two-conductor shielded cabling.
C	24VAC return	18AWG unshielded

Wiring Diagrams

Communication Wiring Options

Indoor Unit Communicating Control
(Using 2-conductor Unshielded Cable for Communication Lines and Separate 2-conductor Unshielded Cable for R and C)

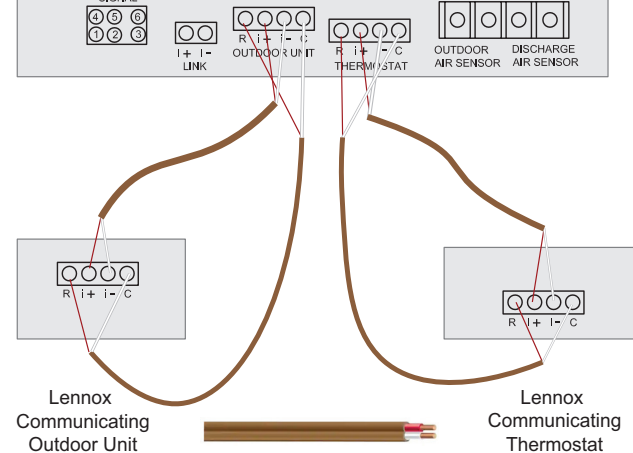
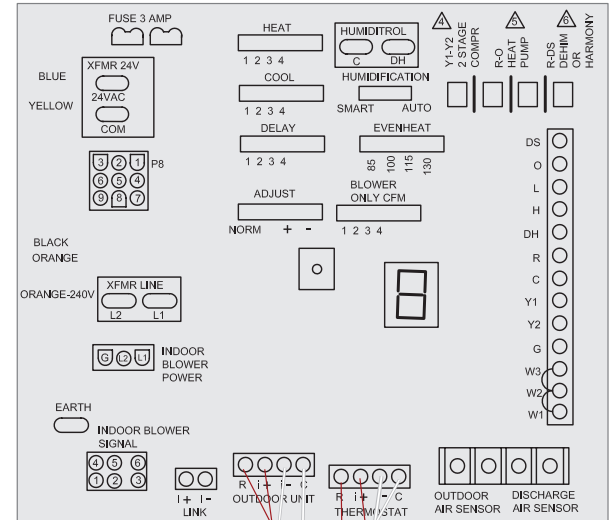

18/2 Brown Solid CU CL2 Thermostat Wire

OPTION 1

Figure 3. Lennox Communicating System Wiring Connections using Separate Unshielded Cable (Option 3)

Indoor Unit Communicating Control
(Using Non-Shielded Wiring)

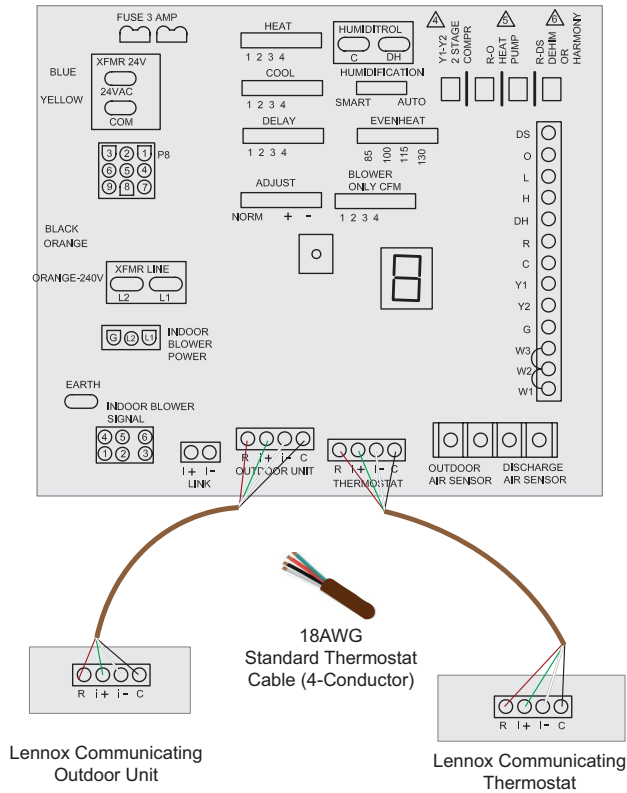

OPTION 2

Indoor Unit Communicating Control
(Using Shielded Wiring for Communication Lines)

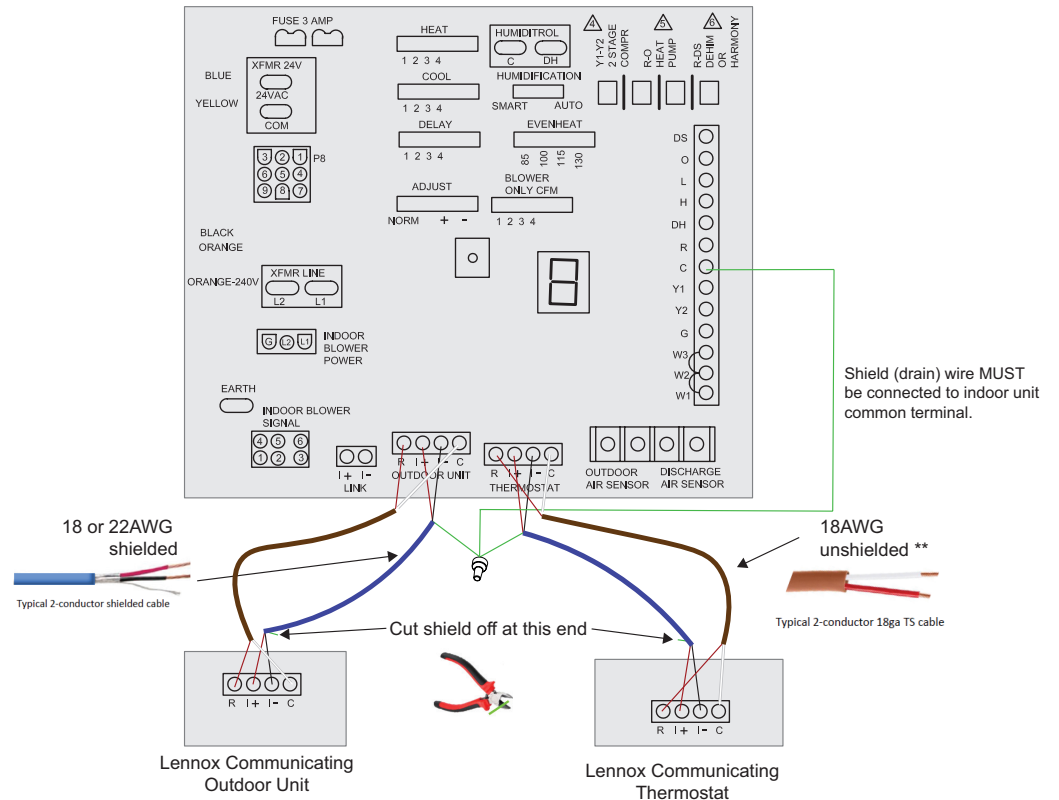

OPTION 3

Figure 4. Lennox Communicating System Wiring Connections using Unshielded (Option 2) or Shielded Wiring (Option 3) Cabling

There may be situations where alternate wirings methods may need to be employed. Two options are available to address an inductive voltage issue. If Alert Code 105 (see “Table 21. Service Alert Notification Codes” on page 54) is still present after following troubleshooting Steps 1 and 2 then proceed to Step 3 wiring options 1 or 3.

- **Option 1** - Using unshielded 2-conductor cable between the indoor, outdoor and thermostat -i and +i terminals may be required.
- **Option 3** - Using shielded 2-conductor cable between the indoor, outdoor and thermostat -i and +i terminals may be required.

NOTE: When using multi-conductor unshielded thermostat cable, refer to “Figure 5. Minimizing Electrical Noise” on page 8.

Minimizing Electrical Noise

When using multi-conductor unshielded thermostat cable, to minimize electrical noise, cap unused wires as illustrated below and run to indoor unit C terminal.

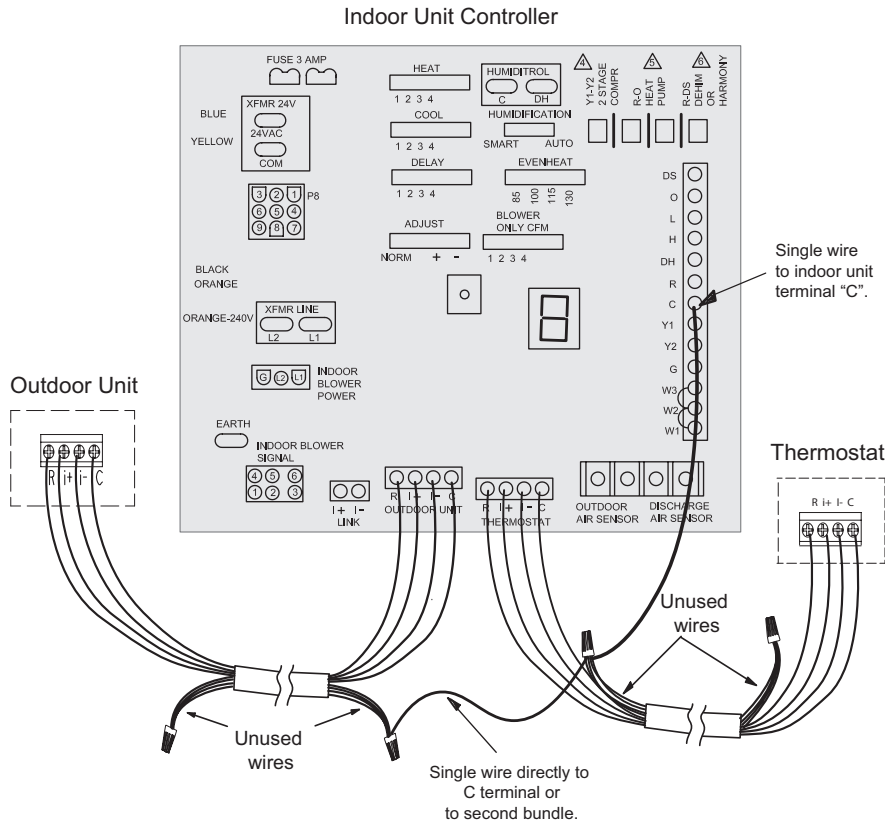

Figure 5. Minimizing Electrical Noise

Application Specific Wiring Diagrams

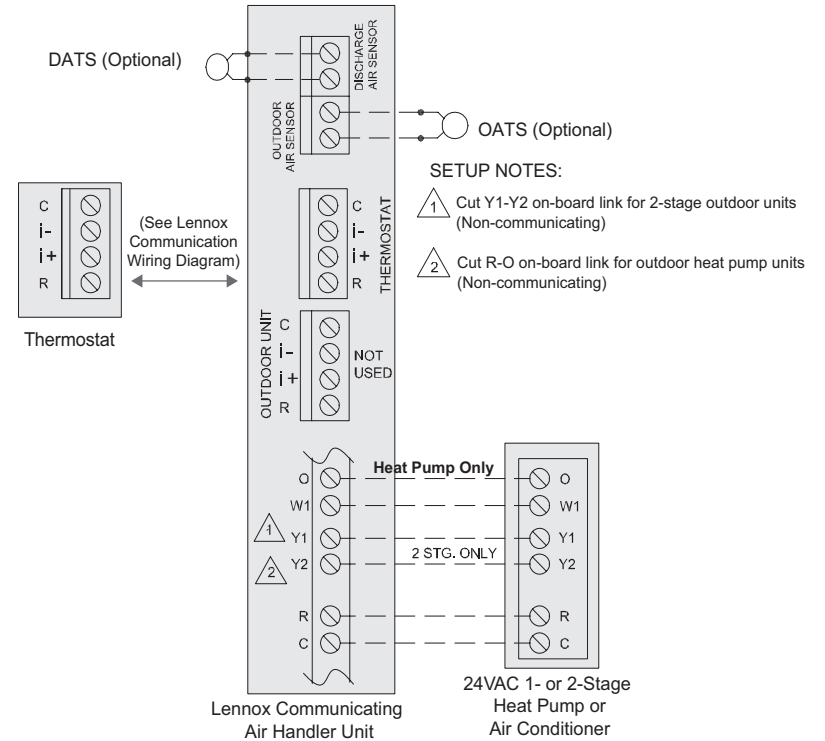

Figure 6. Lennox Smart S40, Lennox Communicating Air Handler with 24VAC (1- or 2-Stage) Heat Pump or Air Conditioner

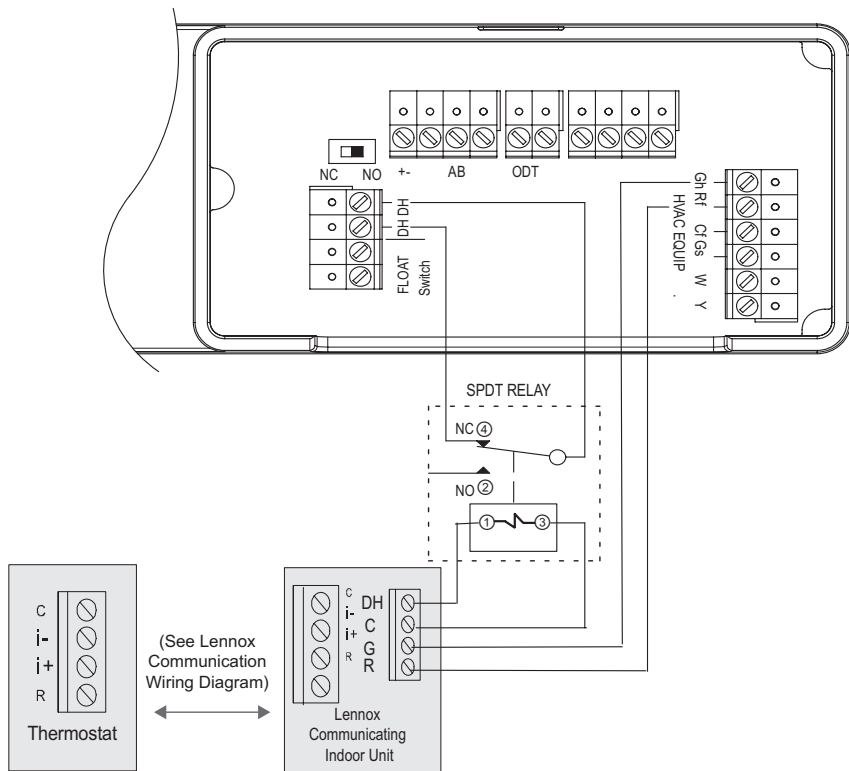

Figure 7. Lennox Smart S40, Communicating Indoor Control (Conventional Connections), Relay and HCWHD4 Series Dehumidifiers

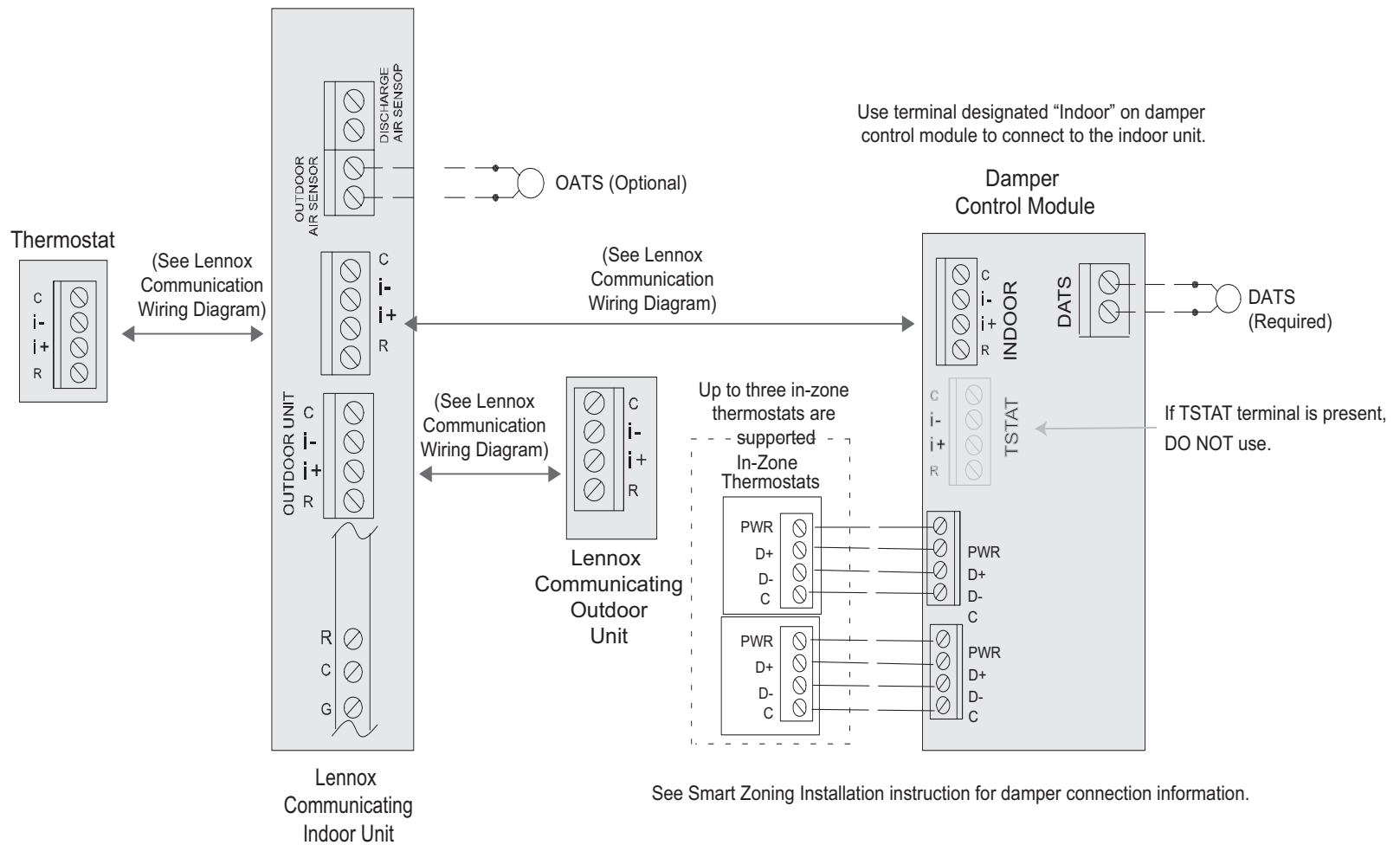
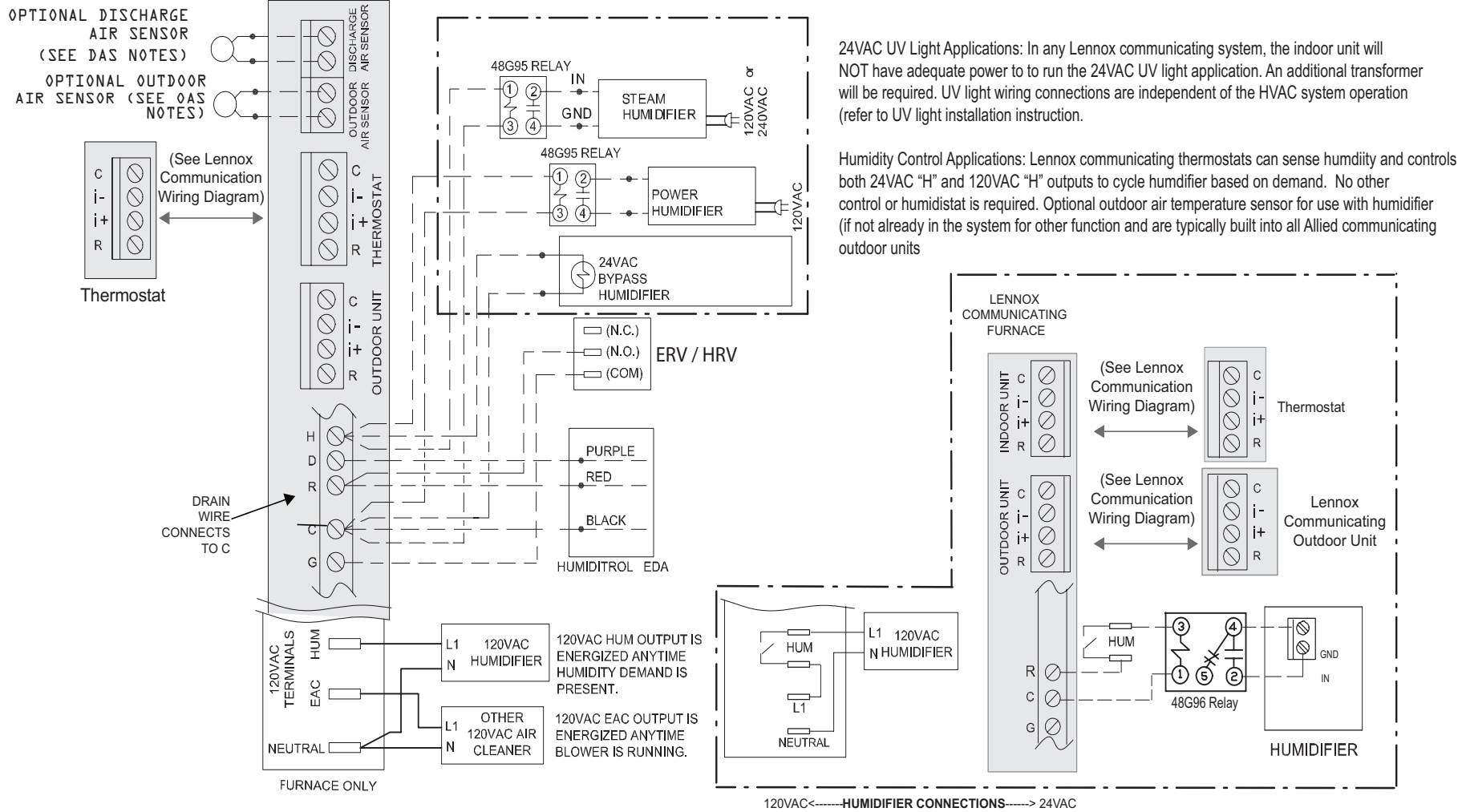

Figure 8. Lennox Smart S40, Lennox Communicating Indoor and Outdoor Units, Smart Zoning System (Damper Control Module) and Zone Sensors

Lennox Communicating
Furnace or Air Handler



24VAC UV Light Applications: In any Lennox communicating system, the indoor unit will NOT have adequate power to run the 24VAC UV light application. An additional transformer will be required. UV light wiring connections are independent of the HVAC system operation (refer to UV light installation instruction).

Humidity Control Applications: Lennox communicating thermostats can sense humidity and controls both 24VAC "H" and 120VAC "H" outputs to cycle humidifier based on demand. No other control or humidistat is required. Optional outdoor air temperature sensor for use with humidifier (if not already in the system for other function and are typically built into all Allied communicating outdoor units

Figure 9. Lennox Smart S40 with Humidifier Accessory

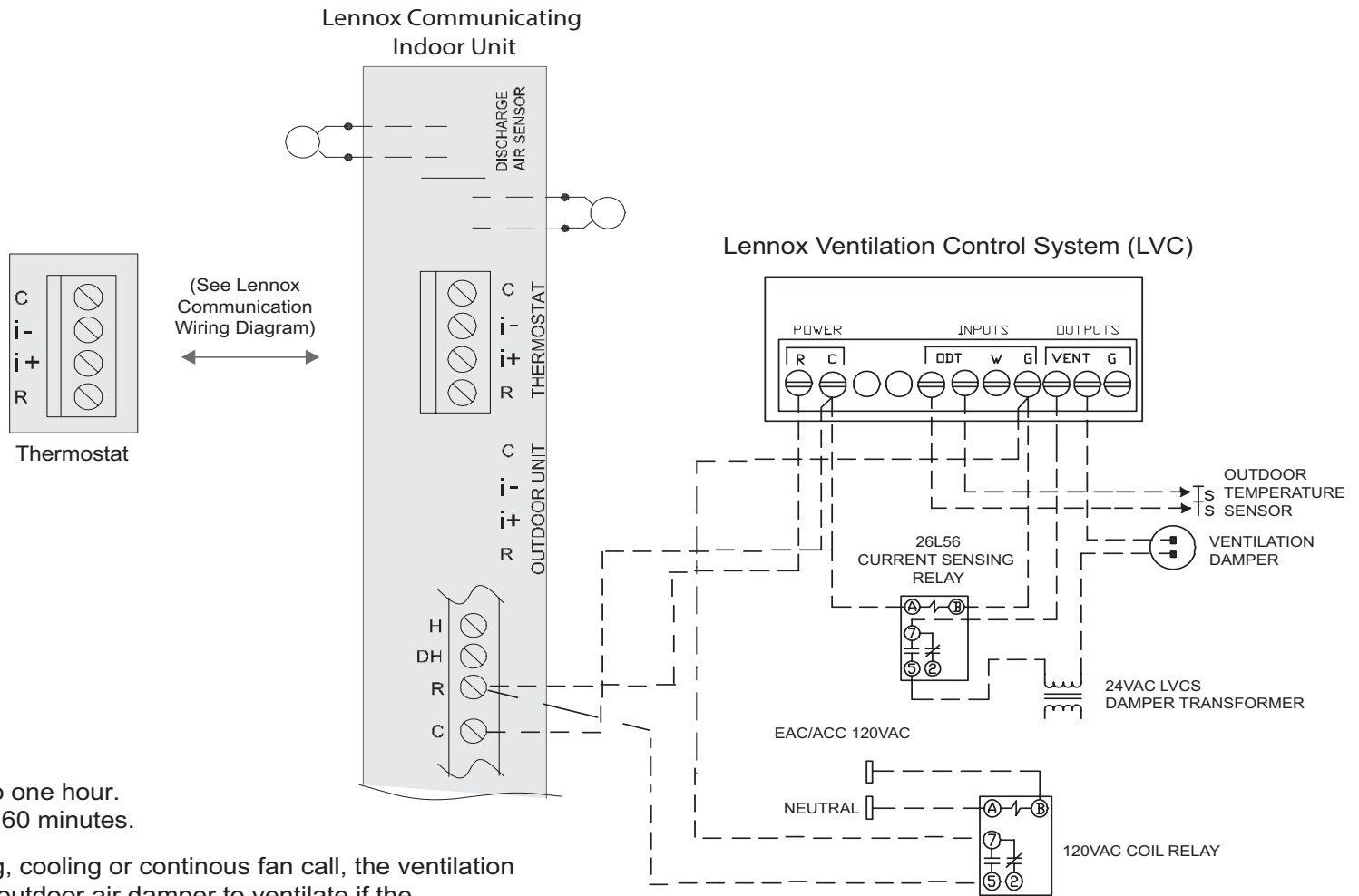

- Set LVCS cycle time to one hour.
- Set ventilation time to 60 minutes.

When there is a heating, cooling or continuous fan call, the ventilation controller will open the outdoor air damper to ventilate if the **outdoor temperature** and **indoor humidity** are within the limits of the ventilation controller.

NOTE: Pass the blower motor L1 wire through the current loop on the current sensing relay as illustrated.

NOTE: Set the communicating thermostat fan mode operation to **Circulate** and adjust duration to match control ventilation time duration.

Figure 10. Lennox Smart S40, Lennox Ventilation Control System (LVCS), Current Sensing Relay, 120VAC Coil Relay, Damper Transformer, Ventilation Dampers and Communicating Indoor Unit (using Non-Communicating Terminals)

LENNOX COMMUNICATING FURNACE
W/ INTEGRAL RDS CONTROL

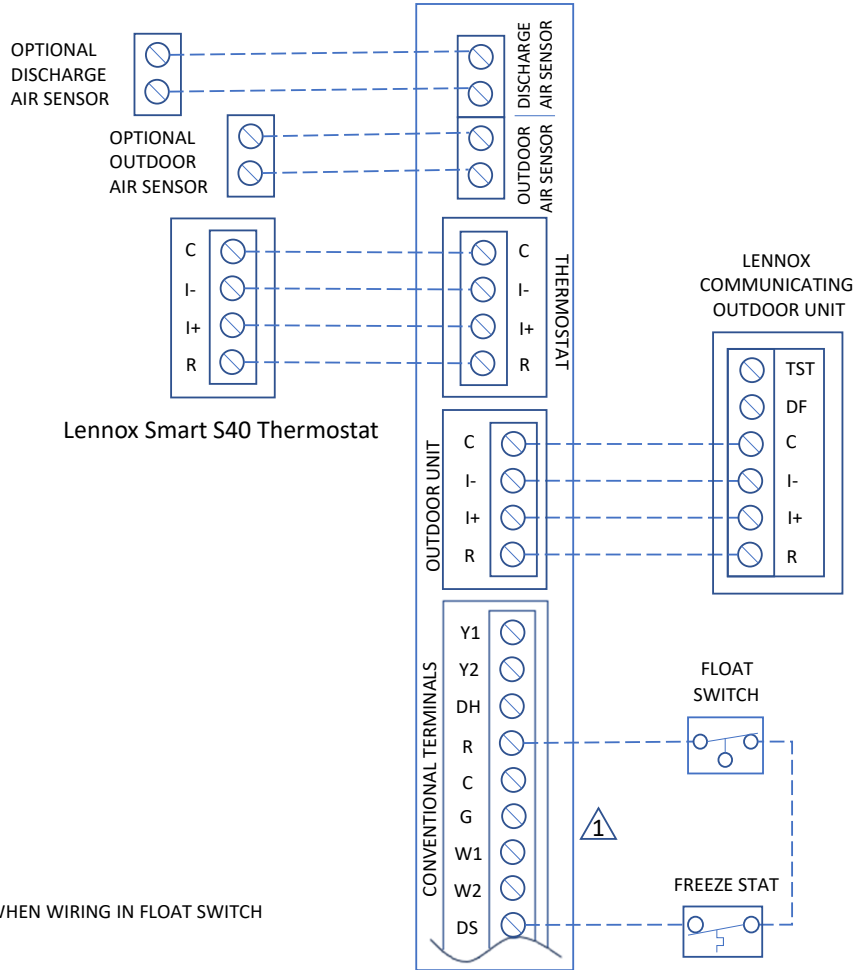

Figure 11. Lennox Smart S40 and HEPA Bypass Filter Interlock Kit and Humidifier

LENNOX COMMUNICATING AIR HANDLER W/
INTEGRAL RDS CONTROL

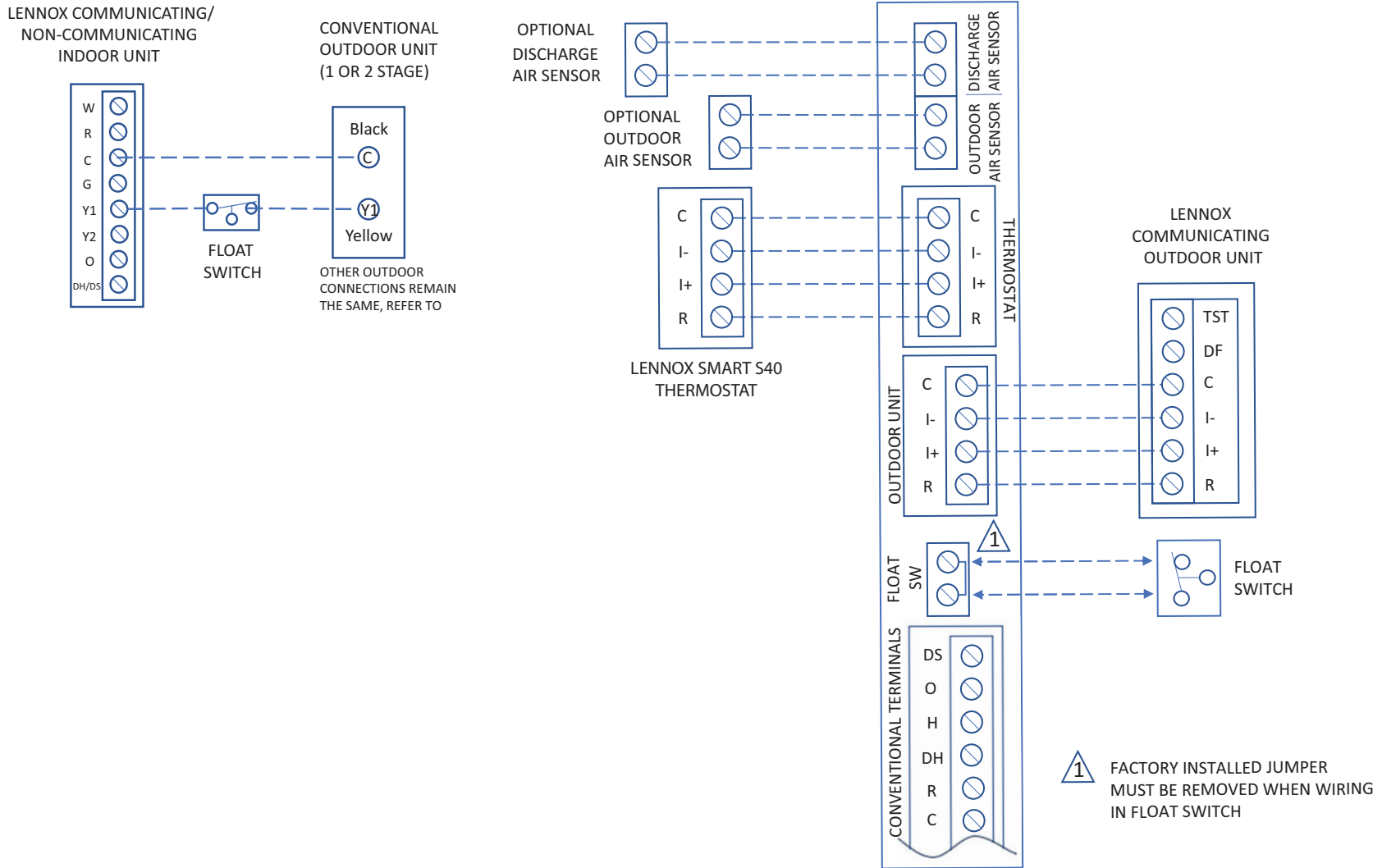

Figure 12. Lennox Smart S40, Lennox Communicating Indoor Controls and Float Switch

LENNOX COMMUNICATING NON-INTEGRAL GAS FURNACE
 UNITS WITH LOW-GWP OUTDOOR UNIT,
 S40 SMART THERMOSTAT & FIELD INSTALLED RDS CONTROL

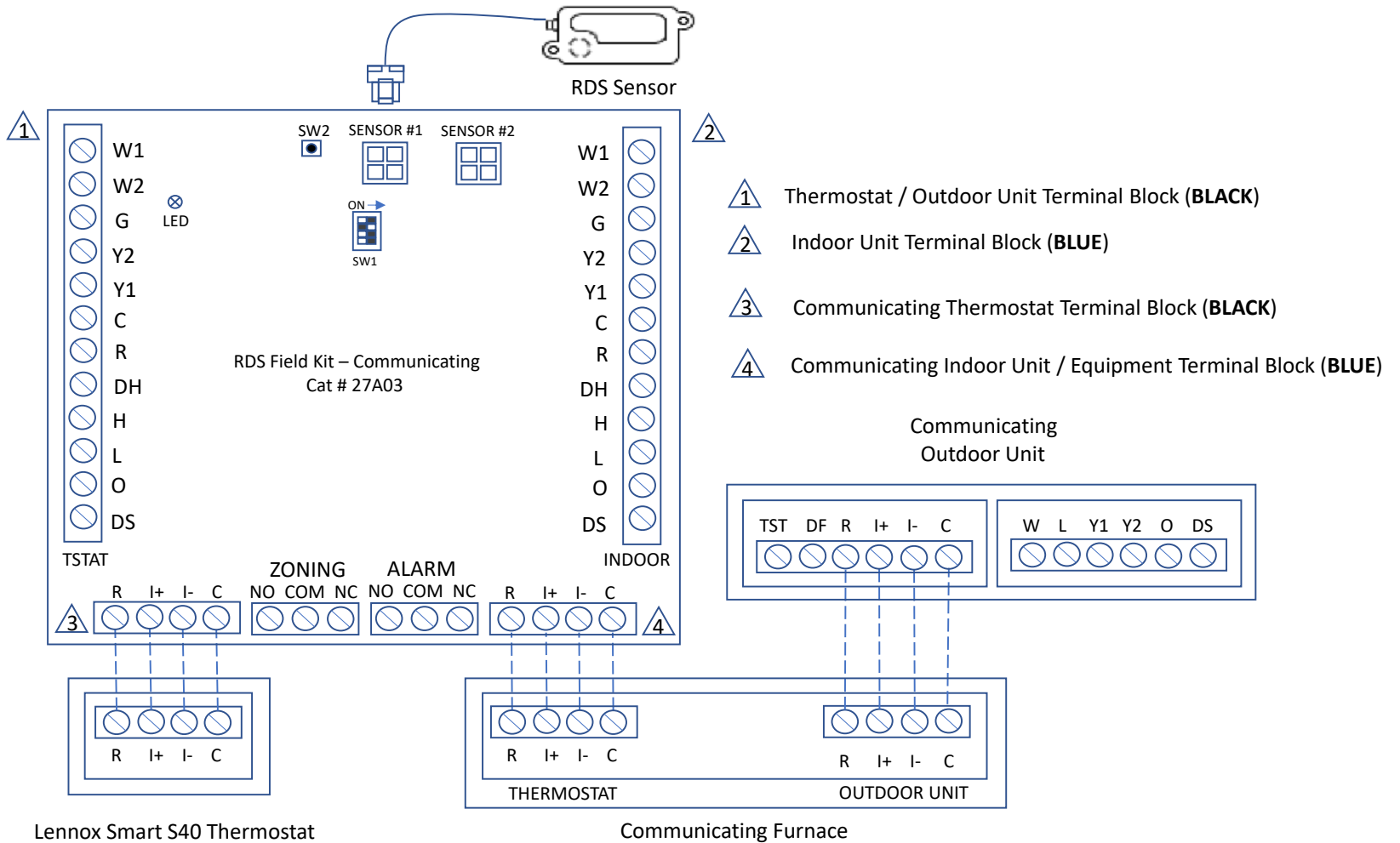

Figure 13. Lennox Smart S40, Lennox Communicating Non-Integral Gas Furnace Units with Low GWP Outdoor Unit and RDS Control

Dual Fuel and Ventilation Diagrams

For additional wiring, please refer to the accessory installation instruction. When using a Lennox Communicating Furnace and conventional heat pump an equipment interface module (EIM) will be required. In addition, ventilation (ERV/HRV and Fresh Air Damper) will also require an EIM. Refer to the EIM Installation and Setup Guide 507240-0x for detailed wiring diagrams for specific application.

Installation Considerations

! WARNING

Improper installation, adjustment, alteration, service or maintenance can cause property damage, personal injury or loss of life.

Installation and service must be performed by a licensed professional HVAC installer (or equivalent) or a service agency.

Before beginning installation, note the type of equipment, number of stages, and any accessories being installed.

Do

- Read this entire document, noting which procedures pertain to your specific equipment and system requirements.
- Conform to local and national building and electrical codes and ordinances.
- Place the thermostat on a central interior wall.
- Installed thermostat a minimum of **5 feet up from the floor**.

Do Not

- Install on voltages higher than 30VAC.
- Exceed 300 feet (91 meters) total wire length when using 18AWG or 22AWG thermostat or smaller diameter wire (see "Table 2. Terminal Designations and Wiring Recommendations" on page 6 for further details).
- Install on outside walls or in direct sunlight
- Install near air return or discharge air vents.
- Install near fireplaces or other heat sources
- Install on exterior walls
- Install near windows or doors
- Install near kitchens
- Install in rarely used rooms or hallways

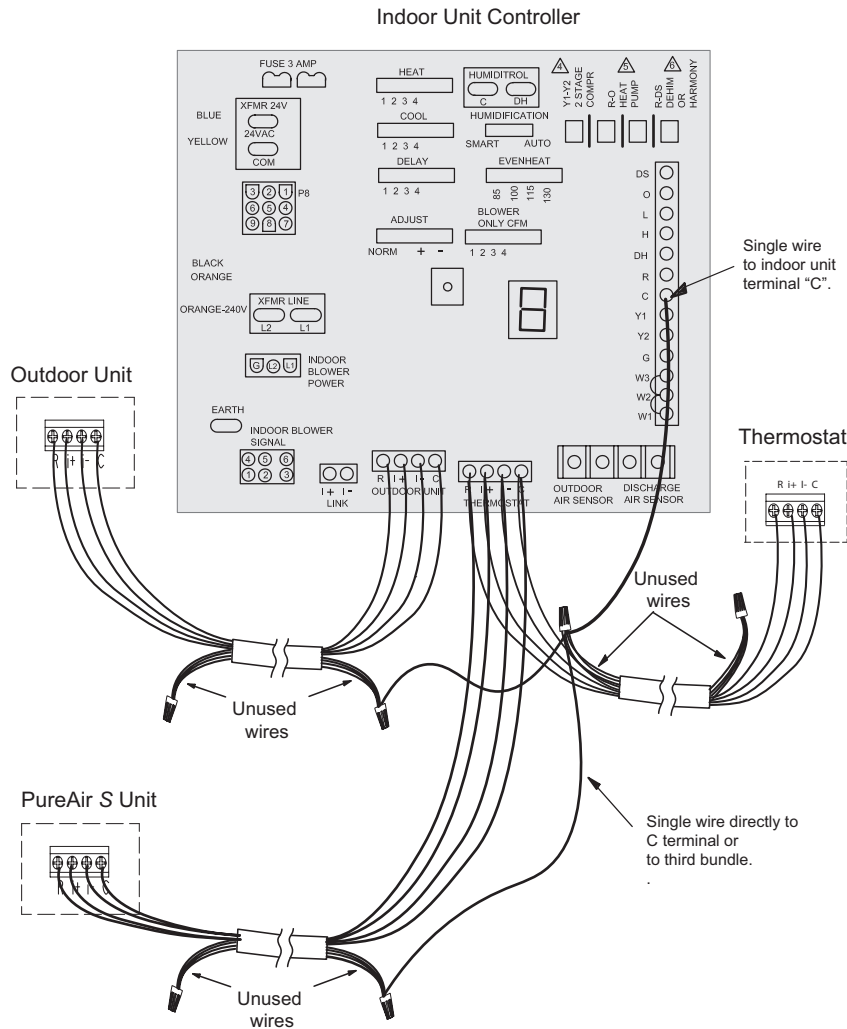

Figure 14. Unshielded Thermostat Cable (Multiple Conductors) used for Wiring Communicating Indoor Unit to PureAir S

Thermostat Installation

Installation

Use the following procedure for installation of the thermostat wall plate where existing thermostat wiring does not exist:

1. Unpack the thermostat and sub-base.
2. Detach sub-base from thermostat body.
3. Determine the best location to install wall plate. Ideal location should be located away from outside wall, direct sunlight or discharge air vents. The thermostat should typically be installed at least **5 feet up from the floor**.
4. Cut or drill a small hole for thermostat wiring.



5. Pull about three inches (75mm) of thermostat wire through the opening and remove the outer thermostat wire jacket.



Seal wire hole in wall to prevent cold or hot air from affecting temperature sensor in display.

! IMPORTANT

Seal wire hole in wall to prevent cold or hot air from affecting temperature sensor in Thermostat.

6. Strip a maximum of 1/4" (6 mm) insulation from end of each wire. For best results, only strip sufficient insulation for wire to insert into the terminals without any wiring exposed.



7. Use a level to align the sub-base or wall plate on wall horizontally.



8. Use sub-base as a template to mark the desired mounting hole locations on the wall.

NOTE: Make sure the UP arrow on the sub-base is pointing up.

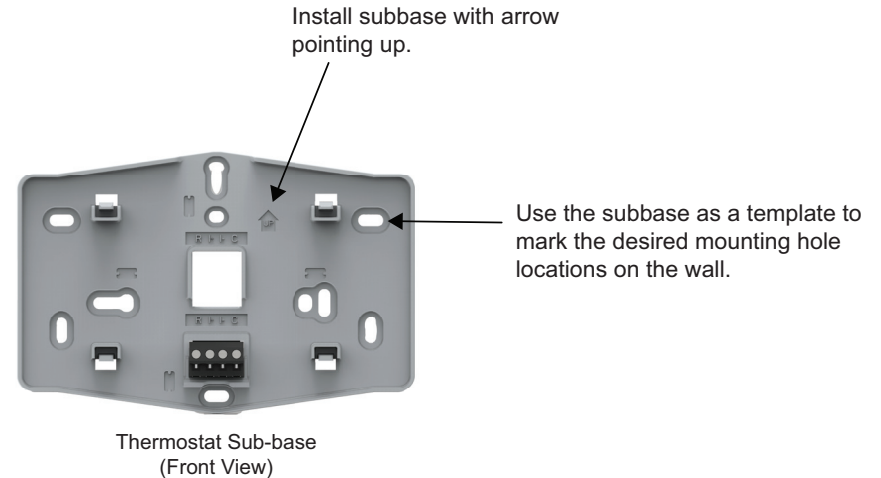

9. Drill 3/16" (5 mm) holes at marked locations on the wall for anchors. Then insert wall anchors into holes until flush with the wall.
10. Secure sub-base with provided #6 x 1.25" pan-head screws (4).
11. Connect thermostat wiring to sub-base screw terminals.

Installing Thermostat to Sub-Base

Install HD Display with UP arrow pointing up when attaching to subbase.

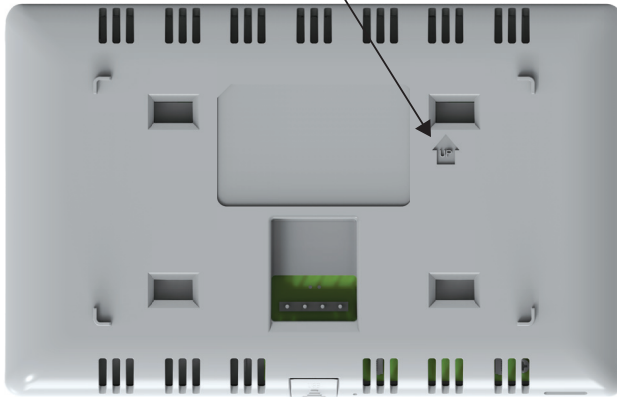

1. Hold the thermostat by the edges, line it up with the sub-base (horizontal position), and move the thermostat toward the sub-base.
2. Center the cavity on the back of the display over the sub-base.
3. Gently press on the edges of the thermostat until you hear the mounting snaps engage. Be careful not to apply force directly on the glass.

NOTE: Once the thermostat is connected, it may take up to 45 seconds for it to power up.

4. To remove the thermostat from the sub-base, grasp the left and right edges of the thermostat and gently pull towards yourself.

NOTE: If the thermostat is removed from the sub-base, the thermostat will shut down and will not be able to communicate with the system. System can be controlled from mobile devices once registration has been completed.

5. Do not remove the label covering the thermostat screen until after power is applied to the system.

Commissioning using the Lennox® Smart Technician



This application tool is used by dealers to commission a S40 Smart Thermostat using a Wi-Fi enabled mobile device.

A temporary direct Wi-Fi connection is created between the mobile device and thermostat using the **Lennox® Smart Technician App**.

NOTE: The **Lennox® Smart Technician App** only connects locally while within Wi-Fi range of the thermostat. The app cannot connect through the home Wi-Fi network or Internet.

To use the **Lennox® Smart Technician App**, the mobile device must be:

- Wi-Fi capable
- Located in the home near the thermostat

NOTE: A router with Bonjour capabilities is required for this function. Check the router features if the thermostat does not connect. Apple Bonjour® is an implementation of zero-configuration networking (Zeroconf), a group of technologies that includes service discovery, address assignment, and host name resolution.

Mobile Device Operating System Requirements

The **Lennox® Smart Technician App** is available for both iOS 11.0 or higher (App Store) and Android 9.0 or higher (Google Play).

Establishing a Direct Wireless Connection to the Thermostat

IMPORTANT

If the connection between the Lennox® Smart Technician App and thermostat is idle for three (3) minutes, the thermostat will auto-disconnect from the mobile device. Repeat procedures to reconnect.

1. Apply power to the thermostat.

IMPORTANT

After applying power to the thermostat, if a “System Under Test” screen appears, it could indicate either the system is under reconfiguration or is unable to communicate with the indoor unit. Check wiring connections between the thermostat wall plate and indoor unit for loose or incorrect connections.

NOTE: When Lennox controls are configured for a communicating system, all jumpers and links setting on the controls are ignored. Jumpers and links setting are treated as defaults and would only be active if the system was configured as a non-communicating system.

2. A **Welcome** screen will appear. Select the desired language to be used. Options are **English**, **Français** and **Español**. Select the **right arrow** to continue.
3. On the **Choose Setup Route** screen there are two options:
 - » Continue setup process through the thermostat
 - » Continue setup process through the mobile app
 Select option 2 and select the **right arrow** to continue.
4. The **Download Lennox® Smart Technician App** screen will appear on the thermostat. On that screen you can scan the QR code with your mobile device to download the *Lennox Smart Technician App* from either App Store or Google Play. If the app has already been installed, select the **right arrow** to continue and proceed to step 6.
5. Once the **Lennox® Smart Technician App** has been downloaded and installed on your mobile device. Return to the thermostat and select the **right arrow** to continue.
6. The next screen is the **Connect Thermostat with Lennox® Smart Technician App**. Select the **Start** button to continue.
7. The next screen is the **Thermostat ID** broadcasting screen. Start the *Lennox® Smart Technician Service App*. Follow the screens on the

Lennox® Smart Technician App.

NOTE: See “Table 3. Lennox Smart Technician App Commissioning Screens” on page 19 for sequence of commissioning.

Commissioning Screens

The following table describes the commissioning sequence and screens in order of their appearance during the commissioning.

Table 3. Lennox Smart Technician App Commissioning Screens

Screen Titles	Selections or Status
Not Connected Welcome - Select Language	English Français Español
Connect to device	S40-XXXXXXXXX will appear. It should match the thermostat ID that is displayed on the thermostat. Select the ID on the app's screen.
Connect with Thermostat	A DIRECT -CHXX-XXX will appear. Select Connect . A confirmation screen will appear indicating successful connection to the thermostat. Select the right arrow to continue.
Dealer Information	Add the dealer ID number and phone number. NOTE: You will not be able to proceed unless either the dealer ID or phone number is entered.
General Information, Time, Date and Units	<ul style="list-style-type: none"> • Select Country / Region • Time, Date, Time Zone and Daylight Savings (You will not need to populate these fields once the thermostat is connected to the Internet). • Temperature Unit • Unit System
Auto-Discovery of Communicating Equipment	Only communicating equipment connected to the thermostat will appear on this screen (thermostat, smart zoning, heat pumps, furnaces, air handlers and air conditioners)
Adding non-communicating equipment	Options None, Fresh Air Damper, HRV, ERV, humidifier, dehumidifiers and non-communicating outdoor units. NOTE: For ventilation equipment, a Lennox Equipment Interface Module will be required.
Zoning Control	If the system has Smart Zoning installed, this screen allows for the renaming of each zone. Assign the specific zone to a location is also available. A custom location is also allowed. The next screen allows adjustments of CFM settings per each zone.
Reminders	Reminders can be set for filters humidifier, UV bulb replacement, maintenance and PureAir maintenances. Additional screens allow for setting filter reminders based on calender time or runtime.
System Name	On this screen the system name can be changed.

Table 3. Lennox Smart Technician App Commissioning Screens

Screen Titles	Selections or Status
Congratulations	Setup is completed. Select Finish . This will take you to the Service Center screen to make any additional changes required to the system.
Service Center	If no other changes are required, the user can terminate the connection to the thermostat by select Disconnect from XXXXXXXX located at the bottom on the screen.

Servicing using the Lennox® Smart Technician App

To use **Lennox® Smart Technician App** as a service tool, the commissioning of the system must have already been completed.

NOTE: *Currently there is a default timer for 30 minutes to complete any service procedures before the thermostat will automatically log you out. The duration of the timer cannot be adjusted.*

1. Download and install the **Lennox® Smart Technician App** if not already installed.
2. From the thermostat home screen, go to **Menu > Settings > Advanced Settings > View Support Service Control Center** and select **Connect To Lennox Smart Technician App**. The thermostat will start broadcasting its Thermostat ID.
3. Start the **Lennox® Smart Technician App** and follow the app screen prompts.

Multiple Thermostats - Group ID

Multiple S40 thermostats in a home can be assigned to a group (up to nine groups with up to five (5) thermostats in each group). All thermostats in a group can communicate with other thermostats in the same group over a single 2.4 GHz Wi-Fi network.

IMPORTANT

If the home will have multiple S40 thermostats then they all **MUST** be on the same 2.4GHz Home Wi-Fi network in order to communicate with each other. Do not use 5 GHz.

All S40 thermostats can be grouped together. If you have a S30 or E30, they will NOT be appear on the S40 thermostat.

Default Group ID 1. Range is 1 to 9.

NOTE: *If a thermostat is set to Group 0, then there is no connectivity with another S40 thermostat within the home on the same 2.4Ghz Wi-Fi network.*

Group IDs can be changed by going to **Settings > Advanced Settings > View Support Service Control Center > Equipment Settings > Thermostat** and look for **Group ID**.

Restarting thermostat

To restart the thermostat, go to **> Settings > Advanced Settings > View Support Service Control Center > Equipment Settings > Reset > Restart Thermostat**.

Automatic Configuration of Existing Equipment

When power is first applied to the system all communicating devices attached to the system (air handler or furnace, outdoor unit, **PureAir S** or zoning control) will automatically be configured using optimal factory default settings based on system type, capacity and other configuration considerations.

NOTE: *If there is a **PureAir S Air Purification System** installed, during commissioning the blower will turn on and run at three different CFM settings for the PCO filter calibration to take place. This may be well in advance before the display is fully up and running. This is a normal process. The blower may run as long as ninety (90) seconds at each CFM setting to complete the filter calibration.*

Setup and Customization Process

The S40 Smart Thermostat has a built-in Setup and Customization Process that walks the homeowner through steps like accepting the End User License Agreement and thermostat features like *Setting a Schedule* and *One-Touch Away*. If the homeowner chooses to bypass the setup and customization process, a *S40 Pending Setup* badge displays on the home screen. The badge displays until the homeowner clears it.

Setup Process

NOTE: *The Setup Process is completed in conjunction with the S40 Smart Thermostat and the Lennox Home app.*

The following initial setup screens are to be completed by the dealer or installer:

- » Welcome (language selection)
- » Choose Setup Route
- » Dealer Information
- » General Settings
- » Auto Discovery of Communicating Equipment
- » System Name (with help of the homeowner)

After completing the aforementioned screens, direct the homeowner to finish the setup process and to customize their thermostat. See “S40 Setup Pending (For Homeowners to Complete)” on page 26.

Customization Process

NOTE: *The Customization Process is completed through the Lennox Home app only.*

The Customization Process allows homeowners to start using the top features of the *Lennox® S40 Smart Thermostat* according to their preferences. After completing the Setup Process, a “Customization is pending” badge appears on the home screen. See *Customize the S40 Smart Thermostat* in the *Lennox® S40 Smart Thermostat User Guide*.

INITIAL SETUP SCREENS (FOR DEALER TO COMPLETE)

1. Power up the thermostat.
2. Select the preferred language on the *Welcome* screen.
3. Press → to advance to the *Choose Setup Route* screen.
4. Select the setup route:
 - » Continue setup process through the thermostat (See “Setup Through the Thermostat” on page 21.)
 - » Continue setup process through the Lennox Home app (See “Setup Through the Mobile App” on page 22.)

Setup Through the Thermostat

1. Select **Setup through the Thermostat** and press → to advance to the *Dealer Information* screen.
2. Complete the **Dealer Information** fields and press → to advance to the *General Settings* screen.
3. Complete the fields in the following sections:
 - » Country/Region
 - » Time and Date
 - » Units
4. Press → to advance to the *Auto-Discovery Communicating Equipment* screen.

This screen identifies all HVAC system components (such as thermostat, smart zoning, heat pumps, furnaces, air handlers, and air conditioners) that are able to communicate with the *Lennox® Smart S40 Thermostat*.

5. Press → to advance to the *Add/Remove Non-Communicating Equipment* screen.

NOTE: *Technicians can press each equipment name, make adjustments, and press **Set** (if changes are necessary).*

Ventilation equipment requires a Lennox Equipment Interface Module.

Zoning may also be detected in systems that have Zoning equipment installed. Technicians can rename zones and assign the zone to a specific location.

6. Press → to advance to the *Setup Wi-Fi* screen.

7. Select **Yes** and press → to advance to the Select a *Wi-Fi Network* screen.
8. Select the homeowner's Wi-Fi network from the list of available networks.
If the home uses a hidden network see "Home Wi-Fi Access Point is Hidden" on page 29.
9. Enter the Wi-Fi password via the virtual keyboard.
10. Press →.
A confirmation dialog displays when a connection is established.
11. Press **OK** to advance to the *Reminders* screen.

Technicians can set service and maintenance reminders for the system's equipment by pressing **Disabled** for each component detected.

NOTE: *Technicians can skip the Reminders screen by pressing → to advance to the System Name screen.*

There are two options by which to set reminders:

- » *Calendar Time* - Select **Custom** to set reminders to a specific calendar date.
- » *Run Time* - Select **3, 6, 12** or **24 Months** to set a *Run Time* period.

12. Press → to advance to the *System Name* screen.

NOTE: *Lennox® recommends renaming the system to a name other than "System" or "system" especially if the homeowner intends to use voice control via a smart home device such as Amazon Alexa. If the homeowner decides to keep the name "System" or "system," the homeowner must address the system as "Thermostat" when using voice control via a third-party smart home device.*

13. Enter a name for the system.

This step is optional, but Lennox recommends asking the homeowner to provide a name for their system.

14. Press →.

The Congratulations screen displays, which confirms the *Lennox® S40 Smart Thermostat* has been successfully set up.

15. Make a selection:

- **Perform Tests** to run Automated or Manual Tests
- **Go to the Dealer Service Center** to access Notifications, Equipment Settings, Information, Tests, Diagnostics, Installation Report, Connect to Mobile App features

NOTE: *Pressing Exit returns the technician to the thermostat home screen.*

Setup Through the Mobile App

1. Select **Continue setup process through the Mobile App** and press →.
The *Download Mobile App* screen displays.
2. Scan the QR code and download the Lennox® Smart Technician Application.
3. Press →.
The *Connect Thermostat with Lennox® Smart Technician App* screen displays.
4. Open the *Lennox® Smart Technician App*.
5. Press
 - Login with my Lennox Pros Account (see "Login with my Lennox Pros Account" on page 22) or
 - Continue without a Lennox Pros Account (see "Continue Without a Lennox Pros Account" on page 25)

Login with my Lennox Pros Account

NOTE: *Installers must log into the Lennox® Smart Technician App (using their LennoxPros username and password) to download their dealership's Equipment Profiles stored within LennoxPros.*

1. Launch the *Lennox® Smart Technician App*.
2. Click **Login with my LennoxPros Account** and enter login and password.
The *Welcome to the Lennox Smart Tech App* screen displays.

NOTE: *The user icon displays in the top right corner of the screen. Click this icon to adjust the language of the app and to verify account details.*

3. Click **Capture Equipment**.

The *Before you start* screen displays after the initial login. The messaging suggests gathering all equipment barcodes before starting the scanning process.

4. Press → to advance to *Create New List or Choose Existing List* screen.
5. Select **Create new list** and press → to advance to the *Create a New List* screen.
6. Enter an identifying name in the **List Name** field and press → to advance to the next screen.

NOTE: *Lennox suggests using identifiers such as JobID, Customer's Name, Job Date, Job Address etc.*

7. Press **Capture** and scan (or manually enter) the barcode of the first piece of equipment.

NOTE: *The installer can either scan the barcode or enter it manually by pressing **Type**. If the equipment is scanned or entered more than once, an exclamation point displays with an accompanying message that notifies the technician the equipment has already been scanned for the list. The app will confirm whether the installer wants to replace the existing equipment with the latest capture.*

If the barcode is valid, a check mark displays and messaging confirms the scan was successful. If the barcode does not scan, an "X" displays and messaging notifies the installer that the code is invalid and encourages the installer to re-scan the code.

8. Repeat step 7 until all equipment has been captured.
9. Press **Finish Equipment Capture** when the last barcode has been scanned.

A summary of scanned equipment displays.

NOTE: *Installers can press the trash can icon to remove scanned equipment from the list. Installers can press ← to return to the *Create A New List* screen to edit the List Name, but all captures will be lost.*

10. Press **Save**.

The app confirms the number of equipment pieces captured.

NOTE: *A maximum of five equipment pieces can be scanned to a single list.*

11. Press **Go to Home**.

The app returns to the *Welcome to the Lennox Smart Tech App* screen.

12. Select **View Captured Equipment**.

The stored list display.

13. Select the newly captured list to verify the equipment associated with the list.

NOTE: *The installer can capture more equipment to add to the list, or press the trash can icon to delete equipment from the list. The entire list can be deleted by pressing **Delete List**.*

14. Press < until the *Welcome To Lennox Smart Tech App* screen displays.

15. Select **Connect to a Thermostat**.

The *Disclaimer* screen displays.

16. Select **Continue Connecting to a TSTAT** and press →.

The *Connect with S40 Smart Thermostat* screen displays.

17. Follow the on-screen instructions.

18. Press →.

The *Lennox® Smart Technician App* searches for and displays available S40 Smart Thermostats.

19. Select the thermostat with the matching ID number and press →.

20. Press **Connect**.

The app connects to the thermostat.

21. Press → to advance to the *Choose Setup Route* screen.

22. Select **Configure New System** and press → to advance to the *Dealer Information* screen.

23. Complete the fields on the *Dealer Information* screen and press → to advance to the *General Settings* screen.

24. Verify the information in the following fields are accurate; make adjustments as necessary.

- Country/Region
- Time and Date
- Units

25. Press → to advance to the *Lennox Smart Thermostat Configuration* language screen.

26. Select a language and press → to advance to the *Auto-Discovery Communicating Equipment* screen.

This screen identifies all HVAC system components (such as thermostat, smart zoning, heat pumps, furnaces, air handlers, and air conditioners) that are able to communicate with the *Lennox® Smart S40 Thermostat*.

NOTE: *Installers can select an equipment item and view the *Equipment Information*, view the current equipment profile settings, or select a different *Equipment Profile* (if one is available). If the installer chooses to make adjustments to a profile, an **Apply Profile Changes** button displays near the top of the screen. Pressing this button applies the newly adjusted profile, but will not override the original profile settings. This is to preserve the integrity of the original profile settings. When the installer returns to the *Auto-Discovery Communicating Equipment* screen, **Modified** displays next to the profile name to indicate the recent profile adjustments.*

27. Press → to advance to the *Add/Remove Non-Communicating Equip* screen.
28. Press **Import Captured Equipment**.
The *Equipment Captured* screen displays.
29. Press > next to the list item (job order/name) to view the equipment on the list.
30. Press **Import list**.
A dialog displays that confirms the list was imported.
31. Press **OK**.
The *Add Manually* screen displays.
The technician can add or adjust the parameters for non-communicating equipment, such as ventilators, humidifiers, dehumidifiers etc.
32. Make adjustments to the parameters for the listed equipment (if necessary) and press **Set**.
33. Press **Done**.
34. Press < to return to the *Add/Remove Non-Communicating* screen.
The newly added equipment displays beneath *Non-Comm. Equipment Added*.
35. Press → to advance to the *Smart Devices* screen.
36. Select **Yes** to add a smart device and follow the on-screen instructions or select **No** to advance to the *Lennox Smart Zoning* screen, if applicable. If the system does not have zoning, proceed to step 38.
37. (Zone Applications Only) Rename the zones. Ask the homeowner to provide a name for each zone.
38. Press → to advance to the *Reminders* screen.

NOTE: *If reminders are not necessary, press → to advance to the System Name screen.*

Installers can set reminders for service and maintenance for system equipment by pressing **Disabled** for each component detected.

There are two options by which to set reminders: *Calendar Time* and *Run Time*.

- *Calendar Time* - Select **Custom** to set reminders to a specific calendar date.
- *Run Time* - Select **three (3), six (6), 12 (twelve) or 24 (twenty-four) Months** to set a *Run Time* period.

NOTE: *Press < Back to return to the Reminders screen.*

39. Press → to advance to the *System Name* screen.

NOTE: *Lennox® recommends renaming the system to a name other than “System” or “system” especially if the homeowner intends to use voice control via a smart home device such as Amazon Alexa. If the homeowner decides to keep the name “System” or “system,” the homeowner must address the system as “Thermostat” when using voice control via a third-party smart home device.*

40. Enter a name for the system.
41. Press → to advance to the next screen.
The *Congratulations* screen displays.
42. Press → to advance to the *Congratulations* screen.
This screen offers two options: *Go to the Dealer Service Center* and *Run Installation Test*.
43. Make a selection:
 - **Go to the Dealer Service Center** to access Notifications, Equipment Settings, Information, Tests, Diagnostics, and Installation Report. After service is complete press **Exit Dealer Service Center**. The *Lennox Smart Technician App* will disconnect from the *Lennox® S40 Smart Thermostat*.
 - **Run Installation Test** and press → to view an installation report.

NOTE: *The system name displays on the thermostat’s home screen (above the temperature), as shown below. If devices were added to the system, press Menu > Settings to view newly added device(s) beneath the Devices heading.*

Notice the *S40 Setup Pending* badge on the thermostat home screen. See “S40 Setup Pending (For Homeowners to Complete)” on page 26.

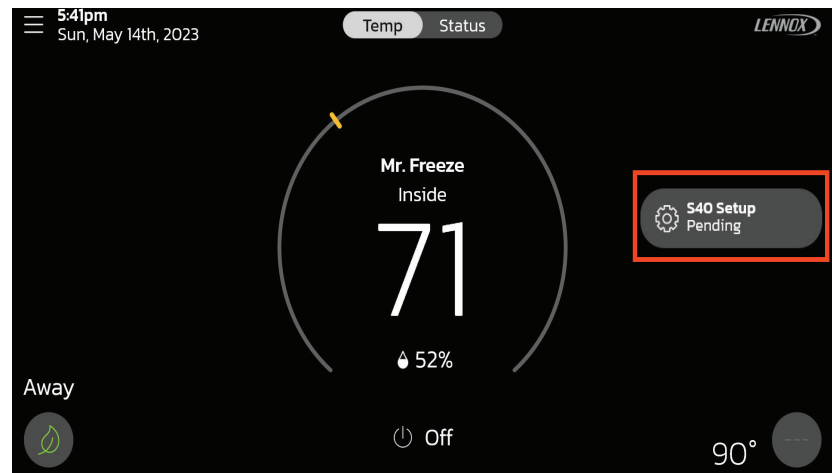

Continue Without a Lennox Pros Account

1. Select *Continue without a Lennox Pros Account*.

The *Connect with S40 Smart Thermostat* screen displays.

2. Read and follow the on-screen instructions.
3. Press →.

The *Lennox Smart Technician App* locates the thermostat.

4. Verify the ID on the thermostat matches the ID listed in the *Lennox® Smart Technician App*.
5. Press the ID number and press →.
6. Press **Connect**.

A check mark displays in the *Lennox® Smart Technician App* to confirm the connection between the app and the thermostat.

7. Press → to advance to the *Choose Setup Route* screen.
8. Select **Configure New System** and press → to advance to the *Dealer Information* screen.
9. Complete the fields on the *Dealer Information* screen and press → to advance to the *General Settings* screen.

10. Verify the information in the following fields are accurate; make adjustments as necessary.

- Country/Region
- Time and Date
- Units

11. Press → to advance to the *Lennox Smart Thermostat Configuration* language screen.

12. Select a language and press → to advance to the *Auto-Discovery Communicating Equipment* screen.

This screen identifies all HVAC system components (such as thermostat, smart zoning, heat pumps, furnaces, air handlers, and air conditioners) that are able to communicate with the *Lennox® Smart S40 Thermostat*.

13. Press → to advance to the *Add/Remove Non-Communicating Equip* screen.

The technician can add or adjust the parameters for non-communicating equipment, such as ventilators, humidifiers, dehumidifiers etc.

14. Press + next to the equipment type and make adjustments (if necessary) and press **Set**.
15. Press → to advance to the *Smart Devices* screen.

16. Select **Yes** to add a smart device and follow the on-screen instructions or select **No** to advance to the *Reminders* screen.

NOTE: *Installation technicians can set reminders for service and maintenance for system equipment by pressing **Disabled** for each component detected.*

Reminder Options:

- *Calendar Time* - Select **Custom** to set reminders for a specific calendar date.
- *Run Time* - Select **three (3)**, **six (6)**, **12 (twelve)** or **24 (twenty-four) Months**.

17. Press → to advance to the *System Name* screen.

NOTE: *Lennox® recommends renaming the system to a name other than “System” or “system” especially if the homeowner intends to use voice control via a smart home device such as Amazon Alexa. If the homeowner decides to keep the name “System” or “system,” the homeowner must address the system as “Thermostat” when using voice control via a third-party smart home device.*

18. Enter a name in the *System Name* field.

19. Press → to advance to the *Congratulations* screen.

This screen offers two options: *Go to the Dealer Service Center* and *Run Installation Test*.

20. Make a selection:

- **Go to the Dealer Service Center** to access Notifications, Equipment Settings, Information, Tests, Diagnostics, and Installation Report. After service is complete press Exit Dealer Service Center. The *Lennox Smart Technician App* will disconnect from the *Lennox® S40 Smart Thermostat*.
- **Run Installation Test** and press → to view an installation report.

The system name displays on the thermostat’s home screen (above the temperature), as shown in the following image.

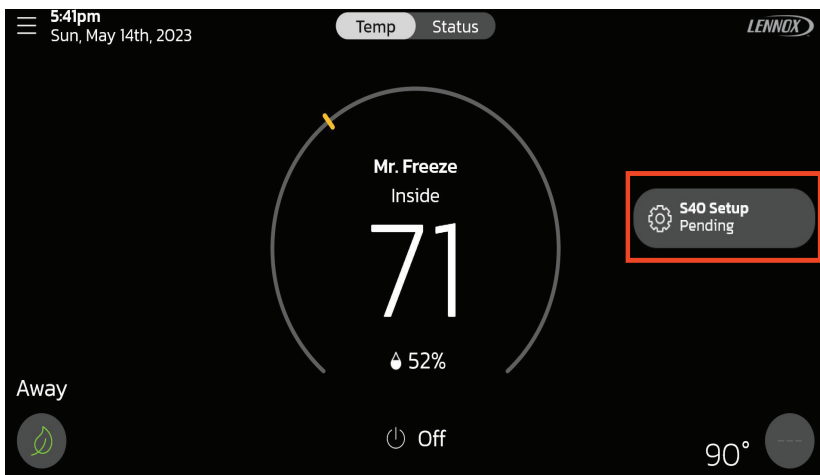

NOTE: If devices were added to the system, press **Menu > Settings** to view newly added device(s) beneath the *Devices* heading.

Notice the *S40 Setup Pending* badge on the thermostat home screen.

See “S40 Setup Pending (For Homeowners to Complete)” on page 26.

S40 SETUP PENDING (FOR HOMEOWNERS TO COMPLETE)

The *S40 Setup Pending* badge displays as a reminder to the homeowner that the setup process is not 100% complete. Direct the homeowner to complete the setup by pressing the badge.

1. Press the **S40 Setup Pending** badge on the thermostat home screen.
2. Press **Yes** to continue with the thermostat customization.
The *Welcome to your Lennox S40 Smart Thermostat* screen displays.
3. Press → to advance to the *Thermostat Language* screen.
4. Select the preferred language for the *S40 Smart Thermostat* and press → to advance to the *End-User License Agreement for Lennox* screen.
5. Review the End User License Agreement (EULA) and select **I Agree to the LENNOX EULA** and press →
The *Lennox S40 User Account* screen displays.

ADDING THERMOSTAT TO ACCOUNT (FOR HOMEOWNERS TO COMPLETE)

This phase of the Setup Process walks the homeowner through the steps of adding their *Lennox® S40 Smart Thermostat* to their account. *If the homeowner does not have a user account, see “Selecting No” on page 27 for instructions on how to establish an account.*

Selecting Yes

The system asks if the *Lennox Home App* is installed on the homeowner’s mobile device.

NOTE: *If the Lennox Home app is not installed on the mobile device, “Download Lennox® Smart Applications” on page 5.*

1. Press **Yes** and press → .
The *Log In to the Lennox Home App* screen displays.
2. Press → .
The *Lennox Home App Menu* screen displays.
3. Follow the on-screen instructions.
 - a. Tap **Menu** on the *Lennox Home App*.
 - b. Select **Add Thermostat** (or press the thermostat icon on the screen).
The *Add Thermostat* screen displays.
4. Return to the *S40 Smart Thermostat* and press → .
The thermostat generates a PIN number.
5. Enter the PIN number into the **PIN number** field in the *Lennox Home App* and press **Add**.
6. Enter the PIN number into the **PIN number** field in the *Lennox Home App* and press **Add**.
The *Thermostat Added* dialog displays. This message confirms the thermostat successfully paired with the mobile device and has been added to the user account.
7. Press **OK**.
The *Create Home or Select Existing Home* screen displays.
See “Create Home or Select Existing Home (For Homeowners to complete)” on page 27.

Selecting No

1. Select **No** and press →.
The *Download the Lennox Home App* screen displays.
2. Scan the QR code and download the *Lennox Home App*.
3. Return to the *Lennox® Smart Thermostat* and press →.
The *Create your User Account* screen on the *Lennox Home App* screen displays.
4. Follow the directions on the screen:
 - » Open the *Lennox Home App*
 - » Tap on **Create New User Account**
 - » Begin the registration process
5. Press → on the thermostat screen until the system generates a PIN number.
6. Return to the *Add Smart Thermostat* screen in the *Lennox Home App*.
7. Press +.
8. Enter the temporary PIN from the thermostat in the **PIN Number** field.
9. Press **Add**.
The *Thermostat Added* message displays.
10. Press **OK**.
The *Create Home or Select Existing Home* screen displays.

CREATE HOME OR SELECT EXISTING HOME (FOR HOMEOWNERS TO COMPLETE)

1. Select **Create New Home** and press → to advance to the **Add Home** screen.
2. Complete the following fields:
 - » Home Name
 - » Country/Region
 - » Address 1
 - » Address 2
 - » City
 - » State
 - » Zip/Postal Code

3. Press →.

The app returns to the home screen.

The newly entered Home Name now displays on the home screen of the thermostat. A badge displays.

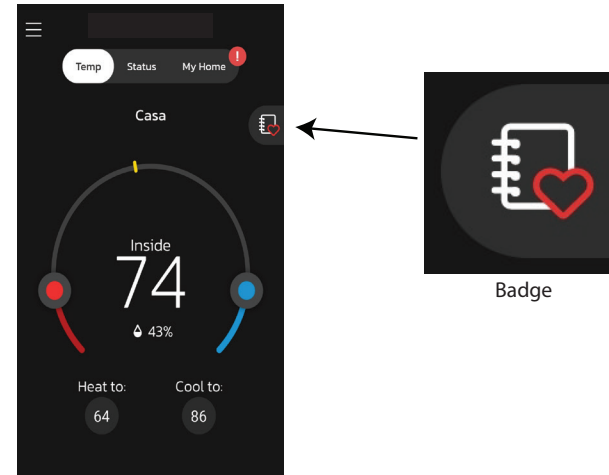

The badge is the customization reminder. Encourage the homeowner to customize their thermostat. The Customization Process can be found in the *Lennox® S40 Smart Thermostat User Guide*.

Helping the Homeowner Connect Thermostat to Home Wi-Fi

MULTIPLE S40 THERMOSTATS IN THE HOME

If the home will have multiple S40 thermostats then they all **MUST** be on the same 2.4GHz Home Wi-Fi network in order to communicate with each other.

! IMPORTANT

If the home will have multiple S40 thermostats then they all **MUST** be on the same 2.4GHz Home Wi-Fi network in order to connect to each other. Do not use 5 GHz.

Wi-Fi CONSIDERATIONS

- This thermostat cannot connect to a home wireless router that uses more than 32 characters in the wireless access point name (visible or hidden).
- This thermostat will support up to a 63 character Wi-Fi password. Passwords cannot contain blank spaces or % symbol.
- If the home Wi-Fi connection is unsecured, then Wi-Fi security **MUST** be enabled. Consult router documentation on how to enable Wi-Fi security
- This thermostat supports the following Wi-Fi security protocols: **WEP**, **WPA**, **WPA2** and **WPA3**.
- Never use a home guest account.
- Always use a secure connection physically located in the home where the thermostat is located.
- Lennox S40 and S30 Smart Thermostats are not designed to communicate with each other even when on the same network.

SUPPORTED WI-FI NETWORK TYPES

Supported wireless network types are listed as follows:

Table 4. Supported Wi-Fi Standards

Standard	Description
802.11b	Compatible.
802.11g	Compatible.
802.11n (Wi-Fi 4)	Compatible.
802.11ac (Wi-Fi 5)	Compatible. NOTE: MIMO is not supported.
802.11ax (Wi-Fi 6)	Not directly supported. Wi-Fi 6 routers are 100% backwards compatible with Wi-Fi 5 and older Wi-Fi devices. NOTE: MIMO is not supported.

Home Wi-Fi Access Point is Visible

1. From the thermostat's home screen, go to **Menu > Settings > Wi-Fi**.
2. Slide the option to the **ON** position to enable **Wi-Fi**.
3. Press on **Not Connected** to display a list of available access points.
4. Locate home network and select the **network name**.
5. Enter the home Wi-Fi network password and press **join** to continue. If successful the **Thermostat Connective Status** indicator as illustrated below will show check marks across all connections.

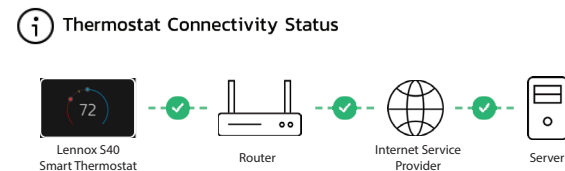

Figure 15. Thermostat Connectivity Status

NOTE: Whether connecting to a visible or hidden network, if successful, a check mark will appear above both the router, and Internet icons. For information on connecting to hidden networks, please reference the S40 Homeowner Guide.

Home Wi-Fi Access Point is Hidden

1. Slide the option to **ON** to enable Wi-Fi.
2. Wi-Fi network will show not connected. Press on “**not connected**”.
3. Scroll down and select **other**.
4. The “**enter new network information**” screen will appear. Enter the name of the hidden network.

NOTE: *The thermostat can connect to a home wireless router that uses up to 32 characters in the access point name (visible or hidden). DO NOT connect to a guest access point.*

5. Select Security. Options are: none, WEP, WPA, WPA2 and WPA3. If your home Wi-Fi connection is unsecured, then Wi-Fi security must be enabled using WEP, WPA, WPA2 or WPA3 via the router before proceeding. Consult your router documentation on how to enable Wi-Fi security.
6. Once security type is selected, a password field will appear. Enter the password to connect to your home Wi-Fi network.

NOTE: *If you wish to see the characters you are typing, check show password. The thermostat will support up to a 63 character password. Passwords cannot contain blank spaces or % symbol.*

7. Press **join**.

Whether connecting to a visible or hidden network, if successful, a check mark will appear above both the router and Internet icons.

Wi-Fi Terminology

The following terminology is used in this troubleshooting section:

- Received Signal Strength Indication (RSSI). This indicates the signal strength of the Wi-Fi router being received by thermostat. So the higher the RSSI number (or less negative in some devices), the stronger the signal.
- Wireless networks supported by this thermostat are:

Table 5. Supported Wi-Fi Standards

Standard	Description
802.11b	Released in September 1999, it's most likely that the first home router was 802.11b, which operates in the 2.4GHz frequency and provides a data rate up to 11 Mbps.
802.11g	Approved in June 2003, 802.11g was the successor to 802.11b, able to achieve up to 54Mbps rates in the 2.4GHz band, matching 802.11a speed but within the lower frequency range.
802.11n (Wi-Fi 4)	Approved in October 2009 and allows for usage in two frequencies - 2.4GHz and 5GHz, with speeds up to 600Mbps.
802.11ac (Wi-Fi 5)	Current home wireless routers are likely 802.11ac-compliant, and operate in the 5 GHz frequency space with support speeds up to 866.7 Mbps NOTE: <i>MIMO is not supported.</i>

- Internet Protocol Address (IP address). This is an address assigned by your home router for each network device (e.g., computer, printer, thermostat).

Electromagnetic Interference Causing Poor Connectivity: Locate the thermostat and router away from other devices that could possibly interfere with wireless communications. Some examples of other devices that could interfere are:

- Microwave ovens
- Wireless cameras
- Portable phones and bases
- Baby monitors
- Wireless speakers
- Bluetooth devices
- Garage door openers
- Neighbor's wireless devices

To eliminate a possible source of interference, temporarily disable any devices and see if Wi-Fi performance has improved.

Received Signal Strength Indication (RSSI)

The ideal signal strength range for the thermostat is -1 to -69 RSSI. The signal strength can be viewed from the thermostat interface.

1. Press **NETWORK SETTINGS**; this screen shows a graphical view of buttons representing OPEN and SECURE wireless networks, along with button for adding a network.
2. Select the access point that has already been established and connected.
3. When selecting the right arrow (>), a screen will appear which will display an option to forget the network. Additional information displayed on the screen is IP address, subnet mask, router IP, DNS, MAC Address, Speed, wireless type, BSSID and RSSI.

NOTE: If the RSSI signal strength is anywhere between -1 to -69, then the signal strength is sufficient. If outside this range, then either relocate the router closer to the thermostat, add a repeater, or move the thermostat. Adjusting antenna on router or extender/repeater may resolve the issue.

Service Center

This menu provides access for the installer or service technician to perform various functions such as advanced equipment configurations, notifications, tests, diagnostics, installation reports and general information about the system.

To access the service center screen, from the home screen, go to **Menu > Settings > Advanced Settings > View Support Service Control Center**.

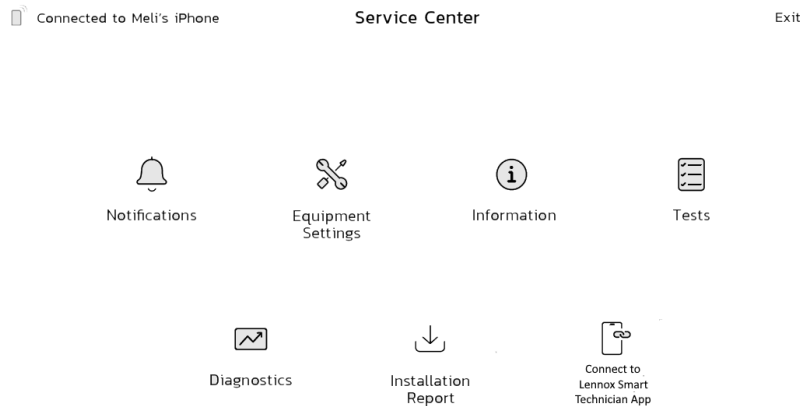

Figure 16. Service Center

Notifications

Any active alert conditions will be listed in this section. Reminders will also be displayed on this screen as well. A list of already cleared notifications is also available.

Equipment Settings

Selections listed in this section are dependent on system hardware configuration. Not all options listed in this section will be available.

NOTE: When changing the default settings for any parameter, there is a possibility that it will affect the settings for another parameter. If this happens, a pop-up message will be displayed listing the other affected parameters and their new automatically set values.

The following is a complete list of all possible parameters listed under **System**. Parameters actually available are dependent on the Lennox communicating equipment type detected and non-communicating equipment added.

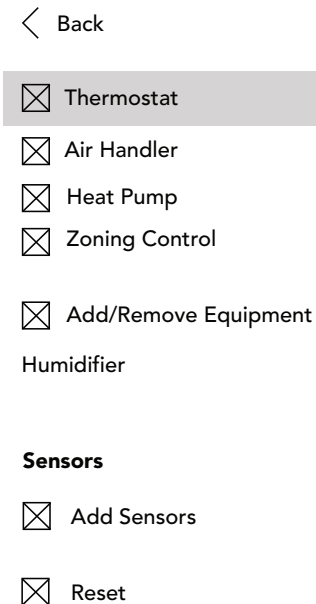

Figure 17. Equipment List

Thermostat

Table 6. Thermostat Parameters

Parameter <i>(In alphabetical order)</i>	Description
About	This screen provides information concerning language supported, equipment type name, control software revision, model, control mode number, control serial number, control hardware revision, protocol revision number, device product level, 24VAC average power consumption, 24VAC peak power consumption, compatible devices list, application code memory size and micro-controller part number.
Auto Brightness	Options are on and off. Default is ON.
Auto Changeover - Humidif. Deadband	Prevents the humidification and dehumidification settings from being closer together than 5% or greater than 10% (Dead-band). Range is 5 to 10%. Default is 5%. Adjustments are in increments of 1%.
Auto Changeover - Temp Deadband	Prevents the heating and cooling from being set closer together than 3°F (1.67°C) or 9°F (5.0°C) (Dead- band). Range is 3 to 9°F (1.67 to 5.0°C). Default is 3°F (1.67°C). Adjustments are in increments of 1°F (0.56°C).
Auto Dehumidification Overcooling Threshold	Adjustments are in increments of 1%. This value can automatically be affected by adjusting other parameters. One example would be when enabling Max Dehumidification Overcooling. Range is 0 - 10%. Default is 4%.
Aux Heating Activation Threshold	<p>This is an adjustment to hasten or delay the aux heat activation. This adjusts how far below the set point the temperature must fall with the HP at 100% before allowing electric heat to come on. Range is 0 - 10°F (0.0 to 5.56°C) with increments of 0.25°F (0.14°C). The default setting is 2.5°F (0.83°C).</p> <p>Definition/Dependencies:</p> <p style="text-align: center;">Step Change versus Steady State Modes</p> <ul style="list-style-type: none"> • Outdoor temperature below the high balance point or with balance points disabled. • Heat Pump demand above 95% for 10 minutes. • Sixty (60) minute temperature rise prediction = less than this Parameter Setting (value) <p>Result:</p> <p>The Heating Proportional Integral Algorithm (as set for less, normal, or more aggressive) will begin to stage on the electric heat to bring the space temperature up to set point.</p> <p>Synopsis: The lower this parameter is set, the quicker the auxiliary heating will respond, in both step change mode and steady state mode.</p>

Table 6. Thermostat Parameters

Parameter <i>(In alphabetical order)</i>	Description
Balance Point Control	<p>If system is set up as dual fuel or heat pump with electric heat and a outdoor temperature sensor connected to thermostat, the low and high balance point settings will appear. The balance points feature requires that a sensed outdoor temperature is provided to the thermostat. The outdoor ambient temperature can be read from either a:</p> <ul style="list-style-type: none"> • Field-installed outdoor temperature sensor (X2658). • Communicating heat pump. All communicating heat pumps have a factory-installed outdoor temperature sensor. <p>Options are enabled or disabled. Default is disabled. When enabled, both low and high balance points can be set.</p>
High Balance Point	<p>This setting is used to prevent the furnace or electric heat from heating the structure. (Alert 19 - Minor - Notification only - The outdoor temperature is higher than the level where the furnace or electric heat is programmed to heat the home.)</p> <p>Range is -17 to 75°F (-27.22 to 23.89°C). Default is 50°F (10.0°C). Adjustments are in increments of 1°F (0.56°C).</p>
Low Balance Point	<p>Setting used to prevent the heat pump from heating the structure. (Alert 18 - Minor - Notification only - The outdoor temperature is below the level where the heat pump is programmed to heat the home).</p> <p>Range is -20 to 72°F (-28.89 to 22.22°C). Default is 25°F (-3.89°C). Adjustments are in increments of 1°F (0.56°C).</p> <p>NOTE: <i>Dual-Fuel Applications (Communicating Systems Only) - Dual fuel applications, which include both a Heat Pump and a gas furnace, will provide multiple stages of heating. For example, a two-stage heat pump would deliver two stages of heat. The gas furnace can add two to four more stages of heat.</i></p>
Brightness Value	The brightness range is 0 - 100. Default 80. Touch either the + or - button to increase or decrease the setting.
CFA Cooling Discomfort Threshold	<p>Default is ON. The purpose of this algorithm when set to ON is to detect systems with faults which are causing measurable loss of comfort and thus, need repair/service intervention.</p> <p>The algorithm monitors the duration in which the indoor temperature is above the cool set point or below the heat set point and does not approach the set-point. When an issue is detected alarm 901 is activated.</p>
Cooling Capacity Alert	<p>Options are ON or OFF. Default is ON. Cooling operation may not be sufficient for the hottest days. Based on local conditions and climatological data for zip code.</p> <p>Examples: Dirty Filter, Low Refrigerant charge, TXV, etc. Symptom during mild temperatures may include; system running longer than normal but not showing any other symptoms.</p>

Table 6. Thermostat Parameters

Parameter (In alphabetical order)	Description
Cooling Mode	Options are Normal and Comfort. Default is Normal. When changing to Comfort Mode, several parameters are automatically modified for optimal system operations. The changed parameters are listed on the screen when set to Comfort. <ul style="list-style-type: none"> Normal - This setting cools the home to the desired temperature setting. Once second-stage is activated by timer or differential, it will not stage down to first-stage until the next cooling cycle demand. Comfort - This is when the system could automatically stage up or down based on the current load demand.
Cooling Prognostics	This algorithm will determine whether the unit will run out of capacity during the hottest time of summer. It will look back everyday a minimum of three days to see if there is a pattern and compare it to the hottest day on record for that zip code before triggering an notification. It must see a pattern before it will trigger the notification. There may be a component or components that will require attention. The sensitivity (threshold) selection options are OFF , LOW , MEDIUM , and HIGH . The default is HIGH . The alert code notification is 65545.
DAT Integral Gain (Lennox Variable Capacity Outdoor Units)	The indicates how stable the system is attempting to reach the discharge air temperature set point. You may hear the compressor hunting (ramping up and down) adjusting to lower setting will correct. Lennox advises not to make changes to this setting without first contacting Lennox technical support or Lennox field technical consultant. Default is 3.0. Range is 1.0 to 15.0 in increments of 0.5.
DAT Offset	This parameter is only available when a Lennox variable capacity outdoor units is installed along with a discharge air temperature sensor (DATS) Installed is used. Default is 0.0°F (0.0°C). Range is -5.0°F to 5.0°F (-2.88 to 2.78°C) in increments of 0.5°F (0.28°C).
DAT Proportional Gain (Lennox Variable Capacity Outdoor Units)	This is how the system attempts to reach the discharge air temperature set point. Lennox advises not to make changes to this setting without first contacting Lennox technical support or Lennox field technical consultant. Default is 3.0. Range is 1.0 to 15.0 in increments of 0.5.
Dew Point Adjustment	The Dew Point Adjustment can be set from -15% to +15%. These settings allow adjustments to the Dew Point setting for the home. Some homes may require an adjustment to help maintain comfort. If condensation is present on windows, set the adjustment lower, between -15% to -5%. If the home feels dry, set the adjustment upwards, between +5 to +15%. NOTE: <i>On some outdoor units, dew point adjustment requires an outdoor air (temperature) sensor (OATS) (X2658) and is automatically controlled by the outside temperature.</i>

Table 6. Thermostat Parameters

Parameter (In alphabetical order)	Description
Display Pure Air	Options are on and off. Default is off. When on it will display the PureAir S information on the home screen. Setting is ignore if PureAir S is not installed.
Display Indoor Humidity	Options are on and off. Default is off.
Display Outdoor Weather	Options are on and off. Default is off.
Electric Heat Control Mode (Single and Two-Stage Lennox Communicating Outdoor Units Only)	In heat pump applications, the electric heat is staged to provide supplemental heat to meet desired comfort levels. When the electric heat section is used in applications that do not have a heat pump, the elements are staged to limit heat so that it meets heating demands only. Options are Standard and EvenHeat. Default is Standard.
Electric Heat Stages During Defrost	Can increase or decrease the number of electric elements to come on during a call for defrost. (Thermostat will have a demand for heat.) Range is 0 to 5 electric heat stages. Default is 2. Adjustments are in increments of 1. NOTE: <i>Selecting 0 will not allow any electric heat stages during defrost.</i>
Electric Heating Activation Hold Time	This parameter represents the amount of time the system waits to check the slope of the temperature against the value in "Aux Heating Activation Threshold" parameter. Range is 0~60 minutes with a default of 10 minutes. Increments are in 5 minute intervals.
Electric Heating Activation Temp Difference	When the system is operating at full heat pump demand, this is the amount of °F (°C) below the set point that is allowed before allowing the use of Aux heat to supplement the heat pump. This parameter is only available when the system is configured with an air handler and variable capacity heat pump. Range is 0.5 - 10°F. Default 1.5°F. Increment of 0.5°F.
Equipment Name	A unique name can be assigned to this component. Name can be up to 29 characters. Name can consist of letters, numbers, special characters and spaces. Default name is subnet controller.
EvenHeat Discharge Temp	When in EvenHeat Control Mode, the thermostat will stage the electric heat sections to maintain a constant discharge air temperature. The system must have a DATS connected to the system to show this parameter. NOTE: <i>Not selectable on Lennox variable capacity outdoor units. Electric heat elements will be staged on by the demand of the thermostat.</i> Range is 85 to 130°F (29.4 to 54.4°C). Default is 85°F (29.4°C). Adjustments can be made in increments of 15°F (8.4°C) .

Table 6. Thermostat Parameters

Parameter (In alphabetical order)	Description
Gas Heat Control Mode (SLP98V only)	Options are Staged, Load Tracking Variable Capacity and Variable Capacity. Default is Load Tracking Variable Capacity Staged: Some furnaces can be configured to provide up to four stages of gas heat operation. When staged heating is chosen, the S40 thermostat allows you to choose between 1, 2, 3 and 4 stages of heat. Single-stage heat: first stage provides 100% of full capacity. <ul style="list-style-type: none"> Two-stage heat: First stage provides 70% of full capacity; 2nd stage provides 100% of full capacity. Three-stage heat: First stage provides 60% of full capacity; 2nd stage provides 80% of full capacity; third stage provides 100% of full capacity. Four-stage heat: First stage provides 35 or 40% of full capacity; second stage provides 60% of full capacity; third stage provides 80% of full capacity; fourth stage provides 100% of full capacity. Load Tracking Variable Capacity: Load tracking variable capacity will smoothly track the load (sensible temperature changes) up and down and adjust the furnace heating rate both ways. Variable Capacity: Variable capacity only tracks the load upward (rising temperature). Variable capacity uses the thermostat stage differentials but not stage timers.
Gas Heating Activation Temp Difference (Lennox Variable Capacity Heat Pumps)	When the system is dual-fuel and steady state while operating at full HP demand, this is the amount of °F (°C) below the set point that is allowed before allowing to switch to gas heat. Range is 0.5 to 10°F (0.0 to -5.56°C). Default is 1.5°F (1.30°C). Adjustments are in increments of 0.5°F (0.14°C).
Heat Cool Stages Locked In Heat Cool (H/C) Stages Lock in default is disabled (heat/cool stages are turned off separately). If changed to Enabled, heat/cool stages are turned off together. <i>For non-variable capacity systems only. See "Table 7. Thermostat Parameters - Heat Cool Stages Locked In" on page 40 for graphics.</i>	
Group ID	Multiple thermostats in a home can be assigned to a group (up to nine groups with up to five thermostats in each group). All thermostats in a group can communicate with other thermostats in the same group over the home Wi-Fi network. If a thermostat is set to Group ID 0, there will be no connectivity with another thermostat. Default Group ID is 1. Valid range is 0 to 9. (Recommend no more than 5 thermostats per group. Doing so will eliminate possible Wi-Fi bandwidth issues.)
HP Heating Lockout Time	The HP could not get a zone to progress 0.5 degrees towards the set point in 120 minutes (Alert Code 40 - Minor alert). System will switch to secondary heat source. (Electric heat or furnace in dual fuel applications). Transition back to Heat Pump normal operation when termination setting times out. Range is 60 to 240 minutes. Default is 60 minutes. Adjustments are in increments of 30 minutes.

Table 6. Thermostat Parameters

Parameter (In alphabetical order)	Description
HP Heating Mode (Lennox Variable Capacity Heat Pumps)	Options are Normal and Comfort. Default is Normal. The normal setting heats the home to the desired temperature setting. Modify the heating comfort mode to limit minimum compressor speed to 60 – 70 percent range and/or adjust comfort mode CFM. <ul style="list-style-type: none"> Normal is when the heat pump will heat the home will providing the highest efficiency. Comfort is when the heat pump will deliver warmer air for comfort, but sacrifices on efficiency.
Humiditrol Comfort Adjust	Options are Maximum Overcooling, Midpoint Overcooling and Minimum Overcooling. Default is Maximum Overcooling. <ul style="list-style-type: none"> Maximum Overcooling: Indoor temperature > (greater than) two degrees above heating set point. Midpoint Overcooling: Indoor temperature > (greater than) HEAT set point + COOL set point / 2. Minimum Overcooling: Indoor temperature > (greater than) two degrees below cooling set point. NOTE: <i>Lennox variable capacity outdoor units are not compatible with Humiditrol (EDA).</i>
Humidity Reading Calibration	If it is determine that the actual humidity percentage being detected at the thermostat is off based on independent readings using other humidity reading devices, the display can be adjusted using this setting. Range is -10.0 to 10.0%. Default is 0.0%.
IAQ Cleaning CFM	Range is 250.0 to 1550.0 CFM. Default is 250.0 CFM and adjustable in 10CFM increments. This is the CFM adjustment when the system is in cleaning mode.
Lock In 2nd Stage HP by Outdoor Temp (Lennox Two-Stage Communicating Heat Pumps Only)	This accessory allows the unit to lock in second stage HP heating when the outdoor temperature goes below the jumper pin setting. Options are off, 40°F (4°C), 45°F (7°C), 50°F (10°C) and 55°F (13°C). Default is off.
Max Heat Setpoint	The highest temperature setting that the heat set point can be set on the thermostat. Default is 90.0F (32.33°C). Range is 60.0 to 90.0°F (15.56 to 32.22°C). Adjustable in increments of 1°F (0.56°C).
Max Humidification Setpoint	This setting will limit the highest humidification setting on the thermostat. This parameter will only appear when a humidifier accessory is installed. Range is 15 to 45%. Default is 45%. Adjustments are in increments of 1%.

Table 6. Thermostat Parameters

Parameter <i>(In alphabetical order)</i>	Description
Min Cool Setpoint	This setting will limit the lowest cooling temperature setting on the thermostat. Range is 60.0 to 90.0°F (15.56 to 32.22°C). Default is 60°F (15.56°C). Adjustments are in increments of 1°F (0.56°C).
Min Dehumidification Setpoint	This setting will limit the lowest dehumidification setting on the thermostat. Range is 40 to 60%. Default is 40%. Adjustments are in increments of 1%.
Minimum Gas Heating Off Time	Range is 2.5 to 10 minutes. Default is 1.5 minutes. Adjustable in increments of .5 minutes.
Modulating Cooling Cycles Per Hour <i>(Lennox Variable Capacity Outdoor Units)</i>	This feature is activated when the structure BTU load is less than the minimum outdoor unit cooling capacity of the outdoor unit. The system will be cycled "ON" and "OFF" at the selected cycles per hour to maintain the settings of the thermostat. (This governs how many cycles per hour the system will try to run when it needs to run at less than minimum capacity). Range is 3 to 6 cycles hours. Can be adjusted in increments of 0.5. Default is 4.

Understanding Modulating Step Change and Steady State PI Gains

Each of these terms has a multiplier (or gain) associated with it called the proportional gain and the integral gain respectively and affect responsiveness and stability

- **Standard** is a moderate gain suitable for nearly all installations.
- **More Aggressive** is a set of slightly higher gains that will make the system more responsive to changes, and will try harder to stay on the set point. This setting may cause some systems to oscillate.
- **Less Aggressive** is a set of slightly lower gains that will make the system less responsive and help to stabilize an oscillating system by sacrificing a small amount of time to set point.

None of the above options will cause the system to end a call if the demand for heating or cooling remains above the minimum capacity of the system since the algorithm is designed to find the demand that allows the system capacity to exactly match the house heating or cooling loss, creating a balance and constant temperature.

Modulating Cooling Step Change PI Gain <i>(Lennox Variable Capacity Outdoor Units)</i>	Step change gains deal with set point changes and affects how fast the system reaches the next set point. Options are less aggressive , standard and more aggressive . Default is standard .
Modulating Cooling Steady State PI Gain <i>(Lennox Variable Capacity Outdoor Units)</i>	Steady state gain controls the demand when the system is not responding to a sensed temperature change away from the S40 thermostat setting. Options are less aggressive , standard and more aggressive . Default is standard .

Table 6. Thermostat Parameters

Parameter <i>(In alphabetical order)</i>	Description
Modulating Gas Heating Cycles Per Hour <i>(SLP98V only)</i>	This feature is activated when the structure BTU load is less than the minimum Heat Pump heating capacity of the outdoor unit. The system will be cycled "ON" and "OFF" at the selected cycles per hour to maintain the settings of the S40 thermostat. (This governs how many cycles per hour the system will try to run when it needs to run at less than minimum capacity). Range is 4 to 10 cycles. Default is 6 cycles. Adjustments are in increments of 0.5 cycles.
Modulating Gas Heating Step Change PI Gain <i>(SLP98V only)</i>	This is applicable to the SLP98V only. Step change gains deal with set point changes and affects how fast the system reaches the next set point (Example: Adjustment to the thermostat setting). Options are less aggressive , standard and more aggressive . Default is standard . Recommend not changing this setting.
Modulating HP Heating Cycles Per Hour <i>(Lennox Variable Capacity Heat Pumps)</i>	This feature is activated when the structure BTU load is less than the minimum Heat Pump heating capacity of the outdoor unit. The system will be cycled "ON" and "OFF" at the selected cycles per hour to maintain the settings of the thermostat. (This governs how many cycles per hour the system will try to run when it needs to run at less than minimum capacity). Range is 3 to 6 cycles. Default is four cycles. Adjustments are in increments of 0.5 cycles.
Modulating HP Heating Step Change PI Gain <i>(Lennox Variable Capacity Heat Pumps)</i>	Step change gains deal with set point changes and affects how fast the system reaches the next set point (Example: Schedule change or adjustment to the thermostat setting). Options are less aggressive , standard and more aggressive . Default is standard . Recommend not changing this setting.
Modulating HP Heating Steady State PI Gain <i>(Lennox Variable Capacity Heat Pumps)</i>	Steady state gain controls the demand when the system is not responding to a sensed temperature change away from the thermostat setting. Options are less aggressive , standard and more aggressive . Default is standard . Recommend not changing this setting.
Number of Gas Heating Stages <i>(SLP98V only)</i>	Number of selectable stages when Gas Heat Control Mode is set in "Staged" mode. Options are 1 through 4. Default is 4.
Outdoor Temperature Reading Calibration	This will allow for adjustment to the outdoor temperature display when the display temperature is off. Outdoor sensor is required. Range is -10 to 10°F (-5.56 to 5.56°C). Default is 0°F (0.0°C). Adjustments are in increments of 1°F. (0.56°C)
Outdoor Temperature Source	Options are off, Internet (AccuWeather®) or sensor. Default is Internet (AccuWeather®).
Preferred Filter Test Window Start Time	Range is 0.0 to 230 hours. Default is 12 hours and increment is 10°F.

Table 6. Thermostat Parameters

Parameter (In alphabetical order)	Description
Proximity Control	Options are ON and OFF. Default is OFF. Is used to wake-up the display from screen saver mode when motion near the Thermostat is detected.
Reset thermostat	Reset thermostat (erases thermostat settings and restarts installer setup).
Screen Locked	Options are unlocked, partially locked and locked. Default is unlocked.
Screen Saver	Options are off, weather, power save and logo. Default is off. NOTE: <i>When the user performs a picture upload from the settings > display > screen saver page, then on this screen it will only indicate that logo was selected. If no picture has been uploaded, then the Lennox logo would be displayed.</i>
Sensor Temperature Difference Limit	This setting determines the temperature differential limit between the smart room sensor and the S40 thermostat. Setting range is 2 to 10°F, and can be incremented 1 degree at a time. Default is 7°F. The system compares the smart room sensor and thermostat temperature difference which by default is 7°F. If the temperature difference between the smart room and thermostat temperatures is greater than or less than 7°F differential then the system determines there is a potential issue with smart room sensor temperature. The system will then raise a notification to the homeowner under the specific smart room sensor with the issue. The system will only use the thermostat temperature reading and ignore the smart room sensor reading until the issue is resolved. The notification displayed to the homeowner is "Device is not participating as temperature readings are abnormally high/low".
Severe Weather Protection (High and low temperature notification.) Options are enabled or disabled. Default is disabled. When enabled either the heat or freezing alert temperature setting will automatically generate a email notification to the homeowner that the applicable condition exist and homeowner interaction is required. NOTE: <i>Notification is dependent on the thermostat having an active Wi-Fi connection and the user account has been setup and includes a valid email address.</i>	
Heat Alert Temperature	This will notify the homeowner when the indoor temperature reaches the setting defined for this parameter. Range is 80°F to 100°F (26.67 to 37.78°C) with a factory default of 90°F (32.22°C). Increments adjusted by 1.0°F (0.56°C).
Freezing Alert Temperature	This will notify the homeowner when the indoor temperature reaches the setting defined for this parameter. Range is 30°F to 50°F (-1.11 to 10.0°C) with a factory default of 40°F 4.4°C). Increments adjusted by 1.0°F (0.56°C).

Table 6. Thermostat Parameters

Parameter (In alphabetical order)	Description
Single Setpoint Mode (SSP) (Non-Zoning System Only) On the user screens this is referred to as Perfect Temp (Temperature). Options are enabled or disabled. Default is disabled. The Single Set Point (SSP) algorithm allows the user the set only one temperature set point value rather than one value for heating and a different value for cooling. When zoning is present, the following SSP settings are not available. When enabled the following parameters are automatically configured for optimal settings. This setting is also available by going to menu > settings > heat & cool > perfect temperature and toggle the feature ON or OFF .	
SSP Heating Cancel Coast Counter Increment Slope	Range is 0 to 0.75°F (0.0 to 0.42°C). Default is 0.25°F (14°C). Adjustments are in increments of 0.125°F (0.07°C).
SSP Heating Cancel Coast Counter Decrement Slope	Range is 0.25 to 2°F (0.14 to 1.11°C). Default is 0.5°F (0.28°C). Adjustments are in increments of 0.125°F (0.07°C).
SSP Cooling Cancel Coast Counter Increment Slope	Range is -0.75 to 0.0°F (-0.42 to 0.0°C). Default is -0.25°F (-0.14°C). Adjustments are in increments of 0.125°F (0.07°C).
SSP Cooling Cancel Coast Counter Decrement Slope	Range is -2.0 to -0.25°F (-1.11 to -0.14°C). Default is -0.5°F (-0.28°C). Adjustments are in increments of 0.125°F (0.07°C).
SSP Heating Lockout Outdoor Temp	When the outdoor temperature is above this setting, heating is not allowed if single set point is running. Range is 50 to 80°F (10.0 to 26.67°C). Default is 70°F (21.11°C). Adjustments are in increments of 1.0°F (0.56°C).
SSP Cooling Lockout Outdoor Temp	When the outdoor temperature is below this setting, cooling is not allowed if single set point is running. Range is 30 to 60°F (-1.11 to 15.56°C). Default is 40°F (4.44°C). Adjustments are in increments of 1.0°F.
Smart Alert Enable	Default is OFF . Smart Alert Enable function when set to ON monitors: <ul style="list-style-type: none"> • Thermostat set point setting • Temperature reading • Determine whether the system moving towards the desired temperature setting or is unable to achieve the desire temperature setting. • Uses local climate design temperatures • System run times.

Table 6. Thermostat Parameters

Parameter (In alphabetical order)	Description								
Smooth Setback Recovery (SSR)	<p>When enabled, smooth set back begins recovery up to two hours before the programmed time so that the programmed temperature is reached at the corresponding programmed event time. Assume 12°F (6.72°C) per hour for first-stage gas/electric heating and 6°F (3.36°C) per hour for first-stage compressor based heating or cooling. With Smooth Set Back disabled, the system will start a recovery at the programmed time. Options are enabled or disabled. Default is enabled.</p> <p>The SSR set point calculation is as follows:</p> <div style="border: 1px solid black; padding: 5px; margin: 10px 0;"> <table style="width: 100%; border-collapse: collapse;"> <tr> <td style="padding: 2px;">For New SSR CSP</td> <td style="padding: 2px;">Current SSR CSP</td> <td style="padding: 2px;">—</td> <td style="padding: 2px;">$\frac{\text{Current Program CSP} - \text{Target Program CSP}}{N}$</td> </tr> <tr> <td style="padding: 2px;">For New SSR HSP</td> <td style="padding: 2px;">Current SSR HSP</td> <td style="padding: 2px;">—</td> <td style="padding: 2px;">$\frac{\text{Target Program HSP} - \text{Current Program HSP}}{N}$</td> </tr> </table> <p style="margin: 5px 0;">Where: CSP = Cool Set Point HSP = Heat Set Point N = number of 30 second intervals to the target program set point Note: N = 240 when target program set point is 2 hours away (maximum recovery time)</p> </div>	For New SSR CSP	Current SSR CSP	—	$\frac{\text{Current Program CSP} - \text{Target Program CSP}}{N}$	For New SSR HSP	Current SSR HSP	—	$\frac{\text{Target Program HSP} - \text{Current Program HSP}}{N}$
	For New SSR CSP	Current SSR CSP	—	$\frac{\text{Current Program CSP} - \text{Target Program CSP}}{N}$					
For New SSR HSP	Current SSR HSP	—	$\frac{\text{Target Program HSP} - \text{Current Program HSP}}{N}$						
<p>Rules for SSR:</p> <ul style="list-style-type: none"> • SSR is enabled when both “Smooth Setback Recovery” is set to enabled (default) and the program schedule is turned on. • SSR does NOT turn off stage delay timers. • SSR will NOT change the dead band between heating and cooling modes. • SSR will not overshoot the target set point. • SSR will reset if the user updates the program schedule during the active SSR period 									
Stage Delay Timers (First)	<p>Enabled (default) setting: When enabled all stage delay timers (stages 2 through 6) are enabled and will serve to bring on additional stage(s) of cooling or heating on a timed basis (default 20 minutes)</p> <p>Disabled setting: All stages delay timers are disabled. Heat/cool stages are changed based on temperature</p> <p>NOTE: <i>The second-stage delay timer (when stage timers is Enabled) is used for both HEATING and COOLING. However, if the system has a variable capacity furnace, zoning or variable outdoor unit, all stage delay timer will be ignored.</i></p>								

Table 6. Thermostat Parameters

Parameter (In alphabetical order)	Description
Stage Delay Timers (2 through 6)	<p>Second through Sixth Stage Delay timer (where applicable) - If staged delay timers are “Enabled”, the default is 20 minutes but can be programmed from 5 to 120 minutes in 5-minute increments. If the first stage fails to advance the ambient temperature toward the set point by 1.0°F (0.56°C) in the programmed delay time, then the second stage is activated.</p> <p>NOTE: <i>The Second Stage Delay Timer (when Staged Delay Timers is Enabled) is used for both HEATING and COOLING. However, if the system has a variable capacity furnace, Second Stage Delay Timer will only be used for COOLING (not for heating, as the variable capacity algorithm ignores delay timers).</i></p>
Stage Differentials (First)	<p>First Stage Differential - Stage 1 differential is used in all thermostats. The default is 1.0°F but can be programmed between 0.5° and 3.0°F in 0.5°F increments.</p>
Stage Differentials (2 through 6)	<p>Number of stages in thermostat is dependent on equipment that is installed.</p> <p>NOTE: <i>Lennox variable capacity systems will stage electric heat but not on differentials. It will use the thermostat PI logic to stage the electric heat. If the system has a variable capacity furnace or zoning all stage differentials will be ignored.</i></p>
Temp Reading Calibration	<p>Range is -5.0 to 5.0°F (-2.78 to -2.78°C). Default is 0.0°F (-0.0°C). If it is determine that the actual temperature being detected at the thermostat is off based on independent readings using other ambient temperature reading devices, the display can be adjusted using this setting.</p>
Temperature Control Mode	<p>The Feels-Like feature factors in the outdoor temperature and indoor humidity for a more accurate control of the temperature in the home. Either an outdoor temperature sensor is used or Internet Weather is enabled for this feature to operate. Modifying this setting here will also change the feature status on the user settings screen.</p> <ul style="list-style-type: none"> • Normal - This setting cools or heats the home to the desired temperature setting (Feels Like is OFF). • Comfort - This setting cools or heats the home to the desired temperature setting (Feels Like) is ON. When set to ON, other parameters are modified to optimal settings for this feature. Those setting changes will be listed on-screen when Comfort is enabled. <p>Default is Normal.</p>
Thermostat Name	<p>Here you can rename the thermostat.</p>

Table 6. Thermostat Parameters

Parameter (In alphabetical order)	Description
Ventilation Control Mode - timed (default)	
Ventilation Minutes Per Hour	<p>Parameter range is 0.0 - 60.0 minutes. Default is 20.0 minutes. Can be adjusted in increments of 1.0 minutes.</p> <ul style="list-style-type: none"> The system first tries to satisfy the ventilation time by only ventilating while conditioning is occurring. NOTE: Continuous fan is NOT considered conditioning. When the required time remaining to ventilate for the hour does not equal the amount of time remaining in that hour, the system begins ventilation and does not stop until the ventilation time requirement is satisfied. When ventilating without a conditioning demand, the ventilation output is active as well as a continuous indoor fan demand. When ventilating with a conditioning demand, the ventilation output is active with the conditioning demand outputs.
Ventilation Rates	
<p>Thermostat ventilation CFM parameters are to be adjusted only after the HRV/ERV set up is completed and the CFMs are known. Once the thermostat's CFMs are adjusted they are used with the thermostat's timer algorithm to determine how long to run the HRV/ERV and to change from low to high speed if a 2-stage HRV/ERVs.</p>	
Ventilation Rate (Only listed for 1-speed ERV or HRV)	Parameter range is 20 - 500 CFM. Default is 130 CFM. Can be adjusted in increments of 1.0 CFM.
Ventilation Rate for Low Speed (Only listed for 2-speed ERV or HRV)	Parameter range is 10 - 200 CFM. Default is 50 CFM. Can be adjusted in increments of 1.0 CFM.
Ventilation Rate for High Speed (Only listed for 2-speed ERV or HRV)	Parameter range is 20 - 500 CFM. Default is 130 CFM. Can be adjusted in increments of 1.0 CFM.
Ventilation High Outdoor Temperature Limit	<p>Parameter range is 60 to 115°F. Default is 100°F. Can be adjusted in increments of 5°F.</p> <p>While the outdoor temperature is equal to or higher than the setting for Ventilation High Outdoor Temperature Limit, ventilation does not run. When locked out due to high outdoor temperature, it will become unlocked when either the outdoor temperature is missing, or when the temperature reported is 1°F less than the Ventilation High Outdoor Temperature Limit setting when display units are in Fahrenheit, or is reported as 0.5°C less than lock out setting when the display units are Celsius.</p>

Table 6. Thermostat Parameters

Parameter (In alphabetical order)	Description
Ventilation Low Outdoor Temperature Limit	<p>Parameter range is -20 to 55°F. Default is 0°F. Can be adjusted in increments of 5°F.</p> <p>While the outdoor temperature is lower than the setting for the Ventilation Low Outdoor Temperature Limit, ventilation does not run. When locked out due to low outdoor temperature, it will become unlocked when the outdoor temperature is missing, or when the temperature reported is 1°F higher than the Ventilation Low Outdoor Temperature Limit setting when display units are Fahrenheit, or is reported as 0.5°C higher than lock out setting when the display units are Celsius</p>
Ventilation High Outdoor Dew Point Limit	<p>Parameter range is 45 to 80°F. Default is 55°F. Can be adjusted in increments of 5°F.</p> <p>While the outdoor dew point is higher than the setting for the high outdoor dew point limit, ventilation does not run. When locked out due to high outdoor dew point limit, it will become unlocked when the outdoor dew point is missing, or when the dew point temperature reported is 1°F less than the lock out setting when display units are Fahrenheit, or is reported as 0.5°C less than lock out setting when the display units are Celsius.</p>
Ventilation Control Mode - ASHRAE	
<ul style="list-style-type: none"> In this mode the thermostat can assist the installer by validating the ventilation CFMs are capable of meeting the ASHRAE required ventilation volumes, but the thermostat has no ability to control CFM from the HRV/ERV. The system first tries to satisfy the ventilation volume by only ventilating while conditioning is occurring. Continuous fan is not considered conditioning. The total volume of ventilation air is accumulated and stored to compare against the target hourly ventilation volume (Vhr). The accumulated value resets each hour. When the remaining required volume of ventilation air for the hour divided by the fan only ventilation rate is equal to or greater than the time remaining to ventilate for the hour and no conditioning is occurring, the system begins ventilation using continuous fan and does not stop until the target hourly ventilation volume requirement is satisfied. When ventilating without a conditioning demand, the ventilation output is active as well a continuous indoor fan demand. When ventilating with a conditioning demand, the ventilation output is active with the conditioning demand outputs. When the system is ventilating, the user interface can indicate as such by showing "ventilating" to the user on the home screen. 	
Ventilation Rates	
<p>Thermostat ventilation CFM parameters are to be adjusted only after the HRV/ERV set up is completed and the CFMs are known. Once the thermostat's CFMs are adjusted they are used with the thermostat's timer algorithm to determine how long to run the HRV/ERV and to change from low to high speed if a 2-stage HRV/ERVs.</p>	
Ventilation Rate (Only listed for 1-speed ERV or HRV)	Parameter range is 20 - 500 CFM. Default is 130 CFM. Can be adjusted in increments of 1.0 CFM.

Table 6. Thermostat Parameters

Parameter <i>(In alphabetical order)</i>	Description
Ventilation Rate for Low Speed (Only listed for 2-speed ERV or HR)	Parameter range is 10 - 200 CFM. Default is 50 CFM. Can be adjusted in increments of 1.0 CFM.
Ventilation Rate for High Speed (Only listed for 2-speed ERV or HRV)	Parameter range is 20 - 500 CFM. Default is 130 CFM. Can be adjusted in increments of 1.0 CFM.
Ventilation Outdoor Condition Override	Options are Disabled (default) or Enabled.
ASHRAE Compliance Check	= NO (Ventilation CFM too low to comply with ASHRAE 62.2) or = YES (Current settings comply with ASHRAE 62.2)
ASHRAE Infiltration Credit	Parameter range is 0.0 - 200.0 CFM. Default is 0 CFM. Can be adjusted in increments of 1.0 CFM.
ASHRAE House Floor Area Served by This Ventilator	Parameter range is 500.0 - 5000.0 square feet. Default is 2500.0 CFM. Can be adjusted in increments of 100.0 square feet. The formula for calculating how much ventilation is required is: (Total square footage of the home/100) + (number of bedrooms+1) x 7.5 cfm
ASHRAE Number of Bedrooms	Parameter range is 1.0 - 10.0. Default is 3.0. Can be adjusted in increments of 1.0.
Fresh Air Damper Ventilation CFM	Parameter range is 20 - 250 CFM. Default is 75 CFM. Can be adjusted in increments of 1.0.CFM
Ventilation Outdoor Condition Override - Enabled	
Ventilation High Outdoor Temperature Limit	Parameter range is 60 to 115°F. Default is 100°F. Can be adjusted in increments of 5°F. While the outdoor temperature is equal to or higher than the setting for Ventilation High Outdoor Temperature Limit , ventilation does not run. When locked out due to high outdoor temperature, it will become unlocked when either the outdoor temperature is missing, or when the temperature reported is 1°F less than the Ventilation High Outdoor Temperature Limit setting when display units are in Fahrenheit, or is reported as 0.5°C less than lock out setting when the display units are Celsius.

Table 6. Thermostat Parameters

Parameter <i>(In alphabetical order)</i>	Description
Ventilation Low Outdoor Temperature Limit	Parameter range is -20 to 55°F. Default is 0°F. Can be adjusted in increments of 5°F. While the outdoor temperature is lower than the setting for the Ventilation Low Outdoor Temperature Limit , ventilation does not run. When locked out due to low outdoor temperature, it will become unlocked when the outdoor temperature is missing, or when the temperature reported is 1°F higher than the Ventilation Low Outdoor Temperature Limit setting when display units are Fahrenheit, or is reported as 0.5°C higher than lock out setting when the display units are Celsius
Ventilation High Outdoor Dew Point Limit	Parameter range is 45 to 80°F. Default is 55°F. Can be adjusted in increments of 5°F. While the outdoor dew point is higher than the setting for the high outdoor dew point limit, ventilation does not run. When locked out due to high outdoor dew point limit, it will become unlocked when the outdoor dew point is missing, or when the dew point temperature reported is 1°F less than the lock out setting when display units are Fahrenheit, or is reported as 0.5°C less than lock out setting when the display units are Celsius.
Wall Insulation	Options are poor, average and good. Default is average.
Wide Setpoint	Options are ON and OFF. Default is OFF. This allows a wider low and high temperature. Normal range is 60 to 90°F (15.6 to 32.2°C) . When this parameter is set to ON, the range is 40 to 100°F (4.4 to 37.8°C). This feature can also be set through the user interface setting screen. From the home screen go to menu > settings > heat & cool (or it may be just heat or cool) > wider set-point range.
Zone 1 through 4 First Stage Differential	Differential is the temperature between when first stage will cycle ON and cycle OFF. (Example: Zone 1 Thermostat is set at 70°F (21°C) with a 1.0°F (0.56°C) differential. Cooling Demand - cooling will cycle ON when the room temperature reaches 70.5°F (21.4°C) and cycle OFF when the room temperature is 69.5°F (20.8°C). Range is 0.5 to 3°F (0.28 to 1.67°C). Default is 1°F (0.56°C). Adjustments are in increments of 1°F (0.56°C). NOTE: For Lennox variable capacity outdoor units the differentials are ignored.

Table 6. Thermostat Parameters

Parameter (In alphabetical order)	Description
Zone 1 through 4 Continuous Blower CFM	<p>Minimum and maximum CFM will be dependent on system component configurations. These parameter values are automatically adjusted to the specific hardware configuration. See Lennox Smart Zoning system installation instruction for minimum CFMs for specific indoor units.</p> <p>Zones requesting the fan ON are only allowed while no other zone demand is present. The thermostat will sum all the zone continuous blower CFM requirements and send the command only after positioning the dampers and waiting for the damper close delay period to expire (30 seconds) Continuous blower demands are the lowest priority demands, all other conditioning demands will over-ride the continuous blower demand.</p> <p>Range is 5 CFM to maximum of indoor unit. Default is dependent on tonnage of indoor unit. Adjustments are in increments of 5 CFM.</p>
Zone 1 through 4 Cooling CFM	<p>Minimum and maximum CFM will be dependent on system component configurations. These parameter values are automatically adjusted to the specific hardware configuration. See Lennox Smart Zoning system installation instruction for minimum CFMs for specific indoor units.</p> <p>Target cooling CFM for a specific zone. Range is 5 CFM to maximum of indoor unit. Default is dependent on tonnage of indoor unit. Adjustments are in increments of 5 CFM.</p>
Zone 1 through 4 Heating CFM	<p>Minimum and maximum CFM will be dependent on system component configurations. These parameter values are automatically adjusted to the specific hardware configuration (See table 9 in Lennox Smart Zoning installation instruction for minimum CFMs for specific indoor units).</p> <p>Target heating CFM for a specific zone. Range is 5 to maximum of indoor unit. Default is dependent on tonnage of indoor unit. Adjustments are in increments of 5 CFM. Adjustments are in increments of 5 CFM.</p>
Zoning Anticipated Discharge Air Temperature Adjustment	<p>This parameter setting compensates for a rapid change of the discharge air temperature due to fast changing conditions. It examines the change in the discharge air temperature for the previous two minutes and extrapolates or looks forward by the number of seconds set in the parameter and uses this as the DATS value for staging. This parameter setting helps prevent limit trip/frozen coil from occurring.</p> <p>Range is 0 to 120 seconds. Default is 0 seconds. Adjustments are in increments of 5 seconds.</p>

Table 6. Thermostat Parameters

Parameter (In alphabetical order)	Description
Zoning Gas Heating DAT Cool Down Target	<p>At the end of a gas cycle, the Heat Blower Off-Delay may not be long enough to completely cool the heat exchanger. This may result in a primary limit trip then, or at the beginning of the next heat demand. This parameter allows the blower to run after a gas heat call ends until the discharge air temperature sensor (DATS) cools to the temperature set in the parameter. If the temperature is set too low this will cause the temperature in the room to overshoot.</p> <p>Range is 80 to 90°F (26.67 - 32.22°C). Default is 90°F (32°C). Adjustments are in increments of 1°F (0.56°C).</p>
Zoning Initial Staging Hold Time for Gas Heating	<p>In zoning systems, the furnace was upstaging before the discharge air sensor reached a steady-state value and it would sometimes trip a limit due to staging up the gas before the blower would even come on (as occurs during pressure switch calibration).</p> <p>In addition and options for delaying the first staging event even further since the starting point of the modulation gas heat in zoning is picked to be appropriate for the airflow being provided, so this parameters allows an adjustment on top of the initial delay. Range: 3.0 – 8.0 minutes, with a default: 5.0 minutes. Can be adjusted in 1 minute increments.</p>
Zoning Minimum Zone Run-Time	<p>Range is 90 to 600 seconds. Default is 120 seconds. Adjustments are in increments of 30 seconds.</p>
Zoning Supply Air Temp Limit for Cooling	<p>In cooling mode, this setting sets the discharge air temperature low limit. Below this temperature, the cooling is turned off.</p> <p>Range is 35 to 45°F (1.67 - 7.22°C). Default is 40°F (4.44°C). Adjustments are in increments of 1°F (0.56°C).</p>
Zoning Supply Air Temp Limit for Gas / Electric Heating	<p>In heating mode, this setting sets the target discharge air temperature.</p> <p>Range is 120 to 160°F (48.88 to 54.44°C). Default is 125°F (52°C). Adjustments are in increments of 5°F (2.78°C).</p>
Zoning Target Supply Air Temp for Cooling	<p>In cooling mode, this setting sets the target discharge air temperature.</p> <p>Range is 40 to 60°F (4.44 - 15.56°C). Default is 45°F (7.22°C). Adjustments are in increments of 1°F (0.56°C).</p>
Zoning Target Supply Air Temp for HP Heating	<p>In heat pump heating mode, this setting sets the target discharge air temperature.</p> <p>Range is 85 to 110°F (29.44 to 43.33°C). Adjustments are in increments of 1°F (0.56°C). Default 90°F (32°C) plus 20 degrees overshoot for both stage and variable capacity systems.</p>
Zoning Target Supply Air Temp for Gas/Electric Heating	<p>Default is 110°F. Range is 100°F to 130°F with 1 degree increment adjustable. In heating mode, this setting sets the target discharge air temperature. Default 100°F (38°C) plus 20 degrees overshoot for both stage and variable capacity systems.</p>

Table 7. Thermostat Parameters - Heat Cool Stages Locked In

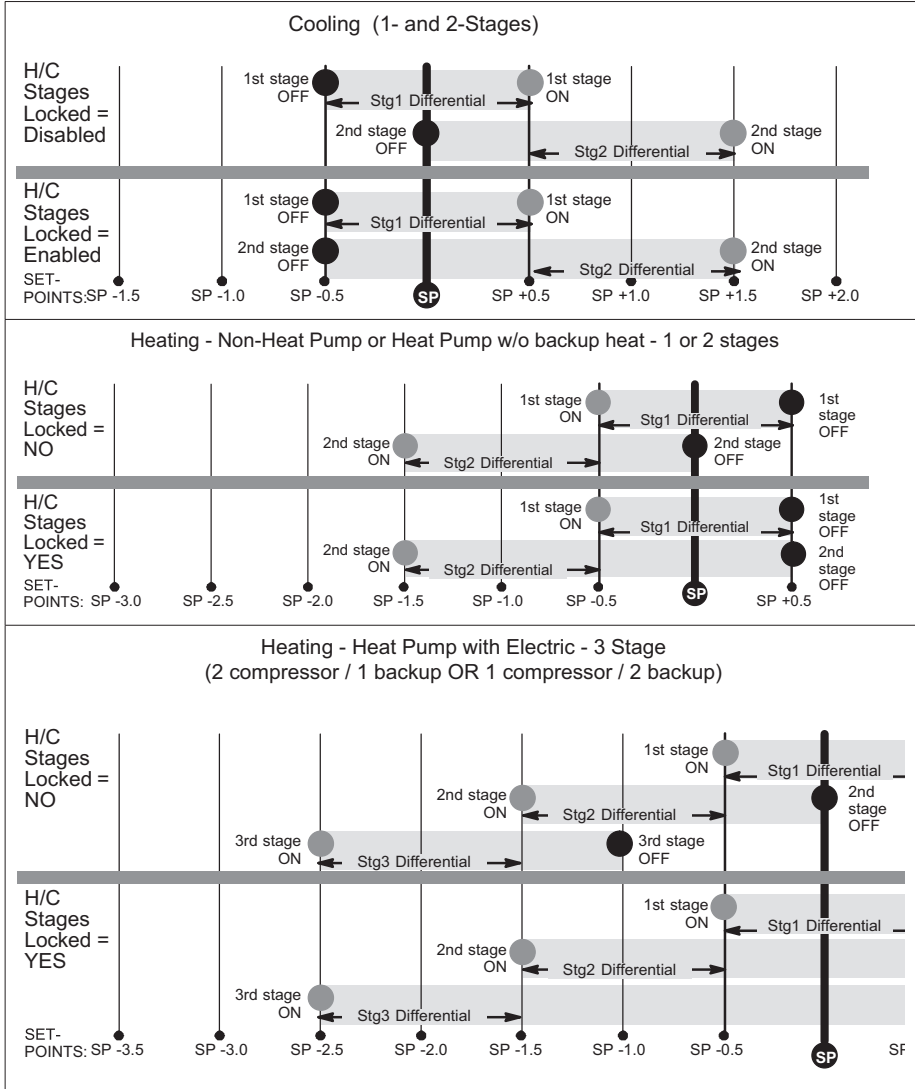

Table 7. Thermostat Parameters - Heat Cool Stages Locked In

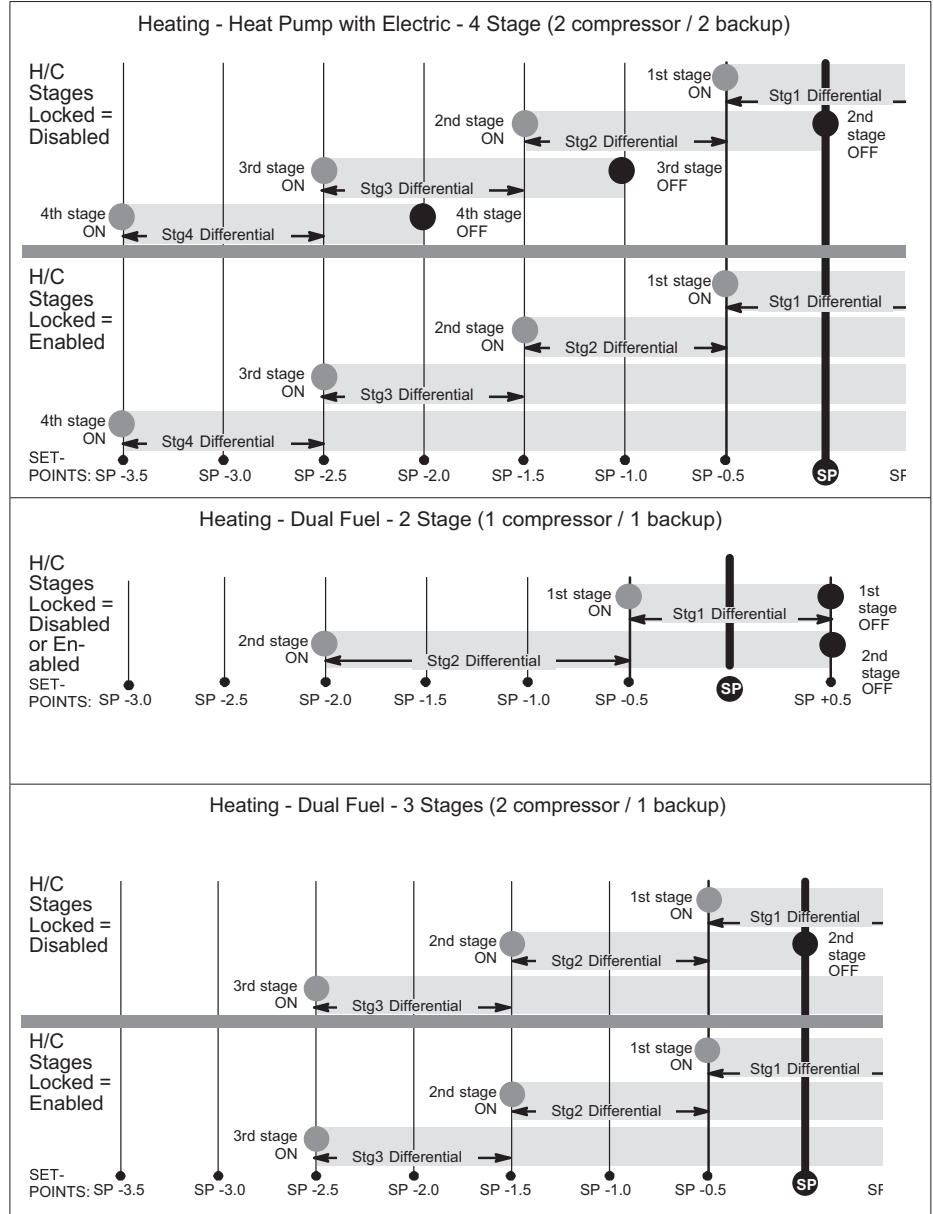

Table 7. Thermostat Parameters - Heat Cool Stages Locked In

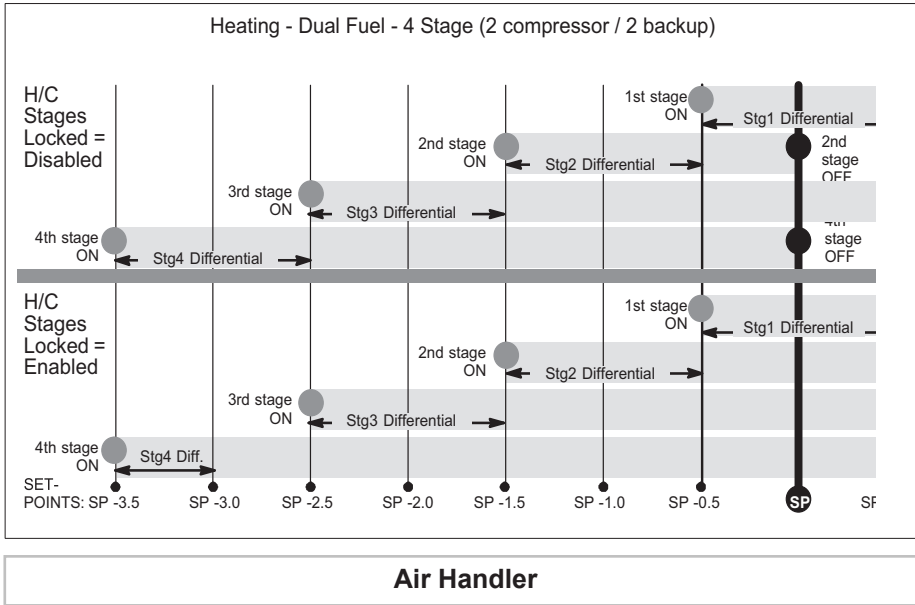

Table 8. Air Handler Parameters

Parameter	Description
Continuous Indoor Blower Airflow	<p>Range of operation of the indoor blower during continuous blower operation.</p> <p>The range is 450 to 2150 CFM. Default is dependent on component match-up. Incremental adjustments are made in 5 CFM.</p> <p>NOTE: All thermostat parameter default CFM values are based on Air Handler Control (AHC) DIP switch setting (non-communicating value) prior to power up. This dip switch settings are use and calculated using CFM conversion tables. They are then rounded up to closest number on 25 CFM resolution. Any DIP switch changes made after power up are ignore.</p>
Cooling Indoor Blower Off Delay	The range is 0 - 30 seconds. Default is 0 seconds with an incremental adjustment of 2 seconds.
Cooling Indoor Blower On Delay	The range is 0 - 10 seconds. Default is 2 seconds with an incremental adjustment of 1 second.
Electric Heating Airflow	<p>Range of operation of the indoor blower during electric heat operation.</p> <p>The range is 1560 to 2150 CFM. Default is dependent on unit capacity with an incremental adjustment of 5 CFM.</p>
Equipment Name	A unique name can be assigned to this component. Name can be up to 29 characters. Name can consist of letters, numbers, special characters and spaces.
Heating Indoor Blower Off Delay	<p>Heating Indoor Blower OFF Delay (Electric Heat only -Blower runs at continuous air CFM setting during delay timing period).</p> <p>The range is 0 - 10 seconds. Default is 10 seconds with an incremental adjustment of 1 second.</p>
Heating Indoor Blower On Delay	The range is 0 - 5 seconds. Default is 0 seconds with an incremental adjustment of 1 second.
High Cooling Airflow	<p>Range of operation of the indoor blower during high cooling operation.</p> <p>The range is 1560 to 2150 CFM. Default is based on cooling demand with an incremental adjustments of 25 CFM.</p>
High HP Airflow	<p>Range of operation of the indoor blower during high heat pump operation.</p> <p>Information below is example only and exact air flow range is dependent on equipment tonnage. Use your example and add adjustment increments of +/-25 CFM</p> <p>Example: The range is 800 -1100 CFM. Default setting is depending on unit tonnage. Can be incrementally adjusted by 25 CFM.</p>
HP Indoor Blower Off Delay	<p>Heat Pump Indoor Blower OFF Delay (Heat Pump only - Blower runs at continuous air CFM setting during delay timing period).</p> <p>The range is 0 - 60 seconds. Default is 45 seconds with an incremental adjustment of 5 seconds.</p>

Table 8. Air Handler Parameters

Parameter	Description
About	Provides information concerning unit code, language support, equipment type name, unit model number, unit serial number, unit nominal capacity, number of heating states, heating capacity by stage, indoor blower CFM range, control software revision, control model number, control serial number, control hardware revision, discharge air temp sensor, outdoor air temp sensor, protocol revision number, device product level, factory installed transformer, 24VAC average power consumption, 24VAC peak power consumption, line voltage average power consumption, line voltage peak power consumption, compatible devices list, applicable code memory size, and micro-controller part number.
Airflow Profile - Cooling	<p>Options are:</p> <ul style="list-style-type: none"> 1 - No delays. 2 - ON: No delays; OFF: 45 sec delay. 3 - ON: 82% - 7-1/2 minutes; OFF: No delays. 4 - ON: 50% - 30 seconds at 82% - 7-1/2 minutes at 100% and finish cycle 50% / 30 seconds off.

Table 8. Air Handler Parameters

Parameter	Description
HP Indoor Blower On Delay	The range is 0 - 30 seconds. Default is 0 seconds with an incremental adjustment of 5 seconds.
Low Cooling Airflow	Range of operation of the indoor blower during low cooling operation. The range is 450.0 to 2150 CFM. Default is based on cooling demand with an incremental adjustments of 25 CFM.
Low HP Airflow	Range of operation of the indoor blower during low heat pump operation. Information below is example only and exact air flow range is dependent on equipment tonnage. Use your example and add adjustment increments of +/-25 CFM. Example: The range is 450 - 600 CFM. Default setting is depending on unit tonnage. Can be incrementally adjusted by 25 CFM.
Reset Air Handler	Any installer modifications under the air handler tab will be reset back to the factory defaults if the reset air handler option is used.

Furnace

Table 9. Furnace Parameters

Parameter	Description
About	This screen provides information on unit code, language supported, equipment type name, unit model number, unit serial number, unit nominal capacity, number of heating stages, heating capacity by stage, indoor blower CFM range, control software revision, control model number, control serial number, control hardware revision, discharge air temp sensor, outdoor air temp sensor, protocol revision number, device product level, factory installed transformer, 24VAC average power consumption, 24VAC peak power consumption, line voltage average power consumption, line voltage peak power consumption, compatible devices list, application code memory size and micro-controller part number.
Airflow Profile - Cooling	Options are: A - ON: 50% - 30 seconds at 82% - 7-1/2 minutes at 100% and finish cycle 50% / 30 seconds off. B - ON: 82% - 7-1/2 minutes at 100% and finish cycle off. C - ON: 100% - No delays; OFF: 45 seconds. D - no delays.

Table 9. Furnace Parameters

Parameter	Description
Continuous Indoor Blower Airflow	The range is 450 - 2000 CFM with a default setting based on equipment type match-up. Adjustments are in increments of 5 CFM. NOTE: All parameter default CFM values are based on Furnace Control (IFC) DIP switch setting (non-communicating value) prior to power up. This dip switch settings are use and calculated using CFM conversion tables. They are then rounded up to closest number on 25 CFM resolution. Any DIP switch changes made after power up are ignore.
Cooling Indoor Blower Off Delay	The range is 0.0 - 30.0 seconds with a default setting base on equipment type match-up. Adjustment are increments of 10 seconds. Default is 0.0 seconds.
Cooling Indoor Blower On Delay	The range is 0.0 - 10.0 seconds with a default setting base on equipment type match-up. Adjustment are increments of 1 second. Default is 2.0 seconds.
Dehumidification Airflow %	Range is 60.0 to 80.0%. Default is 70.0%
Equipment Name	A unique name can be assigned to this component. Name can be up to 29 characters. Name can consist of letters, numbers, special characters and spaces.
Heating Indoor Blower Off Delay	The range is 60 - 180 seconds with a default setting base on equipment type match-up. Adjustment are increments of 10 seconds.

Table 9. Furnace Parameters

Parameter	Description
Heating Airflow Control Type	Options for this setting are fixed CFM or fixed DAT (discharge air temperature). Default is dependent on equipment type match-up. Fixed CFM is selected as the Heating Airflow Control Type (parameter default selection), the circulator will operate at a CFM that is linearly interpolated between Low Heating Airflow and High Heating Airflow based on the current IFC firing rate. For example, if the firing rate is 60% and Low Heating Airflow and High Heating Airflow were set to 500 CFM and 900 CFM respectively (both parameter values are set during the IFC commission), the circulator will run at 297 CFM $(= 500 + (900-500) * (60-40)/(100-40) - \text{assuming } 40\% \text{ minimum fire rate.}$ Fixed Discharge Air Temperature (DAT) control when selected as Heating Airflow Control Type, the IFC will vary circulator at a CFM to maintain a set Discharge Air Temperature (DAT). For example if the firing rate is 60% and Low Heating DAT and High Heating DAT were set to 115°F (46°C) and 130°F (54.4°C) respectively (both parameter values are set during the IFC commission), the IFC will control the circulator to maintain a DAT at 120°F (48.9°C) $(115 + (130-115) * (60-40)/(100-40) - \text{assuming } 40\% \text{ minimum fire rate.}$ When Fix DAT is enabled, the following parameters are available: Low Heating Discharge Temp Range is 105 to 135°F (43.44 to 60.0°C). Adjustable in increments of 5F (2.78°C). Default is 120°F (51.67°C). High Heating Discharge Temp Range is 115 to 145°F (48.89 to 65.56°C). Adjustable in increments of 5F (2.78°C). Default is 130°F (57.22°C).
Heating Indoor Blower On Delay	The range is 15 - 45 seconds with a default setting base on equipment type match-up. Adjustment are increments of 5 seconds.
High Cooling Airflow	Range of operation of the indoor blower during high cooling operation. The range is dependent of indoor unit model and size. Default is based on cooling demand with an Incremental adjustments of 25 CFM.
High Heating Airflow	Both range and default setting is based on equipment type match-up. Adjustments are in increments of 25 CFM. This value is automatically adjusted by the system based on heating airflow control type used.
High HP Airflow	Range is 800.0 to 1100.0 CFM. Default is 967.0 CFM.
HP Indoor Blower Off Delay	The range is 0.0 - 60.0 seconds with a default setting base on equipment type match-up. Adjustment are increments of 5 seconds. Default is 45.0 seconds.
HP Indoor Blower On Delay	The range is 0.0 - 30.0 seconds with a default setting base on equipment type match-up. Adjustment are increments of 5 seconds. Default is 0.0 seconds.

Table 9. Furnace Parameters

Parameter	Description
Low Cooling Airflow	Range of operation of the indoor blower during low cooling operation. The range is dependent of indoor unit model and size. Default is based on cooling demand with an Incremental adjustments of 25 CFM.
Low Heating Airflow	Both range and default setting is based on equipment type match-up. Adjustments are in increments of 25 CFM. This value is automatically adjusted by the system based on heating airflow control type used.
Minimum Gas Heating Off Time	Default is 1.5 minutes. Range is 1.5 to 10 minutes. With increments of 0.5. This setting will help with the Alarm 250 limit tripping in zoning applications where a second zone calls immediately after the satisfying a gas heating call and there is still residual heat in heat exchanger.
Reset Furnace	Any installer modifications under the furnace tab will be reset back to the factory defaults if the reset furnace option is used.

Heat Pump

Table 10. Heat Pump Parameters

Parameter	Description
About	This screen provides information concerning language supported, equipment type name, unit model number, unit serial number, unit nominal capacity, number of heating states, number of cooling stages, heating capacity by stage, cooling capacity by stage, control software revision, control model number, control serial number, control hardware revision, outdoor air temp sensor, protocol revision number, device product level, 24VAC average power consumption, 24VAC peak power consumption, line voltage average power consumption, line voltage peak power consumption, outdoor inverter model number, outdoor inverter firmware version, outdoor fan RPM profile, unit code, compatible devices list, application code memory size and micro-controller part number.
Automatic Max Defrost <i>(Single and Two-Stage Lennox Communicating Heat Pump Units)</i>	When set to ON , the system will always run at MAX DEFROST when accumulated compressor off time is longer than 30 minutes and ambient temperature is less than 35°F (1.6°C). When ambient sensor temperature is higher than 40°F (4.5°C) then defrost termination will be 90°F (32°C). This option has two settings, either ON or OFF . Default is OFF .

Table 10. Heat Pump Parameters

Parameter	Description
Compressor Shift Delay ON / OFF	<p>Single and Two-Stage Heat Pumps: This feature reduces sounds that occur while the unit is cycling in and out of the defrost mode.</p> <ul style="list-style-type: none"> When enabled, there is a 30-second compressor shift delay which de-energizes the contactor and ECM fan outputs. After the delay expires, the contactor and ECM fan outputs are energized. When disabled, the reversing valve is shifted by de-energizing the outputs. <p>Variable Capacity Heat Pumps:</p> <ul style="list-style-type: none"> The “Shift delay” is not a technician settable parameter on variable capacity heat pumps. “Shift Delay” is always enabled going into and out of a defrost. The inverter was updated with “slope logic” and shift delay is always enabled. The shift delay is: Compressor shut off > 4s delay > reversing valve shifts > 26s delay > compressor restarts.
Compressor Short Cycle Delay’ <i>(Single and Two-Stage Lennox Communicating Outdoor Units)</i>	<p>This feature prevents the compressor from being short cycled any time the compressor is turned “OFF”. The range is 60 - 300 seconds. Default is 300 seconds and with an incremental adjustment of 60 seconds. When the system initiates a compressor short cycle delay, the outdoor unit control’s seven segment display will count down the delay in minutes 1 to 5 minutes. The sequence is time remaining and a dash, and will repeat that cycle (5, 4, 3, 2 and 1) until the count down is complete. If the delay timer is change to let’s say 180 seconds, then the countdown will start at 3.</p>

Table 10. Heat Pump Parameters

Parameter	Description
Defrost Termination Temp <i>(Single and Two-Stage Lennox Communicating Heat Pump Units)</i>	<p>This is the temperature that defrost mode will be terminated. In dual fuel applications (furnace and heat pump), defrost tempering is automatically enabled and operates as follows:</p> <ul style="list-style-type: none"> Furnace will run for 75 seconds ON then after 90 seconds OFF for two cycles. After the first two cycles, the furnace will run for 60 seconds ON then cycle OFF for 90 seconds. This cycle will be repeated until the room thermostat is informed by the outdoor control that defrost has terminated. <p>The range is 50 - 100°F (10.0 to 37.78°C). Default is 50°F (10.0°C) and with an incremental adjustment of 10°F (5.56°C).</p> <p>Variable capacity - Both Furnace and Heat Pump are Modulating:</p> <p>When the thermostat receives information that the heat pump has entered defrost the thermostat sends a minimum rate heating demand to the furnace. Then the thermostat terminates the minimum rate heating demand upon defrost completion or any time the heat pump stops. (i.e., pressure switch opens, mode switch changes, etc.)</p> <p>Staged – Both Furnace and Heat Pump are Multi-Stage:</p> <p>When the thermostat receives information that the heat pump has entered defrost the thermostat performs the following :</p> <ul style="list-style-type: none"> Sends a first stage heating demand to the furnace. After 75 seconds elapse from the time the first stage demand was sent, the thermostat terminates the furnace heating demand. After the furnace minimum off time has elapsed (90 seconds) from the time the previous heating termination, the thermostat starts first stage furnace heat again by sending the first stage heating demand. This is the new adjustable gas heat delay setting for zoning. After 60 seconds elapse from the previous heating demand being sent, the thermostat terminates the furnace heating demand. Repeat steps 3 and 4 while defrost is active, terminating any running furnace heat demand when the HP indicates that defrost is no longer active or any time the heat pump stops. (i.e., pressure switch opens, mode switch changes, etc.) <p>NOTE: <i>The on times above assume the minimum furnace ignition time of 35 seconds.</i></p>
Dehum Airflow Adjustment Adder <i>(Lennox Variable Capacity Heat Pumps Only)</i>	<p>Dehumidification airflow = HUMID Mode CFM table value for a given thermostat demand + dehumidification adjustment adder (High Normal Cooling Airflow CFM x Dehumidification Airflow Adjustment Adder in percentage.</p> <p>Both these values are in the installer set up under dealer control center > equipment > heat pump. Range is 0 to 30%. Default is 28%.</p> <p>NOTE: <i>Deactivated in auxiliary dehumidification and enhanced dehumidification accessory (Humiditrol)</i></p>

Table 10. Heat Pump Parameters

Parameter	Description
Equipment Name	A unique name can be assigned to this component. Name can be up to 29 characters. Name can consist of letters, numbers, special characters and spaces.
High Normal Cooling Airflow <i>(Lennox Variable Capacity Heat Pumps Only)</i>	Thermostat values shown are defaults. This value can be adjusted up or down to meet each application requirements. The range is 450 - 2150 CFM. Default is dependent on unit capacity with an incremental adjustment of 25 CFM.
Fan Cycling <i>(Single and Two-Stage Lennox Communicating Heat Pumps)</i>	Options are ON or OFF. Default OFF.
High Normal HP Heating Airflow <i>(Lennox Variable Capacity Heat Pumps Only)</i>	Thermostat values shown are defaults. This value can be adjusted up or down to meet each application requirements. The range is 450 - 2150 CFM. Default is dependent on unit capacity with an incremental adjustment of 25 CFM.
Low Normal Cooling Airflow <i>(Lennox Variable capacity Heat Pumps Only)</i>	Thermostat values shown are defaults. This value can be adjusted up or down to meet each application requirements. The range is 450 - 2150 CFM. Default is dependent on unit capacity with an incremental adjustment of 25 CFM.
Low Normal HP Heating Airflow <i>(Lennox Variable Capacity Heat Pumps Only)</i>	Thermostat values shown are defaults. This value can be adjusted up or down to meet each application requirements. The range is 450 - 2150 CFM. Default is dependent on unit capacity with incremental adjustment of 25 CFM.
Max Defrost by Weather <i>(Single and Two-Stage Lennox Communicating Heat Pump Units)</i>	Options are off and on. Default is off. When set to on, information from the default Internet weather source is used to determine when Max Defrost is used.
Reset Heat Pump	Any installer modifications under the heat pump tab will be reset back to the factory defaults if the reset heat pump option is used.

Air Conditioner

Table 11. Air Conditioner Parameters

Parameter	Description
About	This screen provides information concerning language supported, equipment type name, unit model number, unit serial number, unit nominal capacity, number of cooling stages, cooling capacity by stage, control software revision, control model number, control serial number, control hardware revision, outdoor air temp sensor, protocol revision number, device product level, 24VAC average power consumption, 24VAC peak power consumption, line voltage average power consumption, line voltage peak power consumption, outdoor inverter model number, outdoor inverter firmware version, outdoor fan RPM profile, unit code, compatible devices list, application code memory size and micro-controller part number.
Compressor Short Cycle Delay	This feature prevents the compressor from being short cycled any time the compressor is turned "OFF". The range is 60 - 300 seconds. Default is 300 seconds and with an incremental adjustment of 60 seconds. When the system initiates a compressor short cycle delay, the outdoor unit control's seven segment display will show the delay in minutes from 1 to 5 minutes. The sequence is time (minutes) remaining and a dash, and will repeat that cycle (5, 4, 3, 2 and 1) until the count down is complete. If the delay timer is change for example to 180 seconds, then the countdown will start at 3 (minutes).
Dehum Airflow Adjustment Adder	Dehumidification airflow = "HUMID" Mode CFM table value for a given thermostat demand + dehumidification adjustment adder (High Normal Cooling Airflow CFM x Dehumidification Airflow Adjustment Adder in percentage. Both these values are in the installer set up under System Device/Air Conditioner/High Normal Cooling Airflow).
Equipment Name	A unique name can be assigned to this component. Name can be up to 29 characters. Name can consist of letters, numbers, special characters and spaces .
High Normal Cooling Airflow <i>(Lennox Variable Capacity Air Conditioners Only)</i>	The range is 450 - 2150 CFM. Default is dependent on unit capacity with an incremental adjustment of 25 CFM. Thermostat values shown are defaults. This value can be adjusted up or down to meet each application requirements.
Low Normal Cooling Airflow <i>(Lennox Variable Capacity Air Conditioners Only)</i>	The range is 450 - 2150 CFM. Default is dependent on unit capacity with an incremental adjustment of 25 CFM. Thermostat values shown are defaults. This value can be adjusted up or down to meet each application requirements.
Reset Air Conditioner	Any installer modifications under the air conditioner tab will be reset back to the factory defaults if the reset air conditioner option is used.

Zoning Control

Table 12. Zoning Control Parameters

Parameter	Description
About	This provides information on unit code, language supported, equipment type name, control software revision, control model number, control serial number, control hardware revision, protocol revision number, device product level, 24VAC average power consumption, 24VAC peak power consumption, compatible devices list, application code memory size, micro-controller part number, max number of zones, supported damper types, number of damper positions, zone temp sensor 1, zone temp sensor 2, zone temp sensor 3 and zone temp sensor 4.
Equipment Name	A unique name can be assigned to this component. Name can be up to 29 characters. Name can consist of letters, numbers, special characters and spaces.
Zones 1 through 4 Temp Reading Calibration	Allows adjustment to temperature reading displayed on zone thermostat.
Reset Zoning Control	Any installer modifications under the zoning control tab will be reset back to the factory defaults if the reset zoning control option is used.

PureAir S

Table 13. PureAir S Parameters

Parameter	Description
Equipment	PureAir Filter
Dirty Filter Detection and UV Life Detection	<p>Default: ON. Options are either ON or OFF.</p> <p>This parameter turns on and off the filter life and UV lamp life reporting. When set to off, the control will continue to calculate the remaining filter life through continuous sampling, but will not use filter tests to determine filter life. The control will:</p> <ul style="list-style-type: none"> Perform a filter calibration upon indication of a filter change regardless of the value of this parameter. Perform a UVA lamp calibration upon indication of a lamp change regardless of the value of this parameter. Calculate UVA lamp life remaining regardless of the value of this parameter. <p>Alarms 504 and 503 will not be sent while this parameter is set to "Off"</p> <p>The Diagnostics screen on the thermostat will continue to show values for both filter life and UV lamp life regardless of the value of this parameter.</p>

Table 13. PureAir S Parameters

Parameter	Description
Max Air Filtered between Tests	<p>Default is 100%, Range is 50% to 100% Changes can be made in increments of 10%. This parameter:</p> <ul style="list-style-type: none"> Modifies the amount of air that is allowed to pass through the filter after a valid % life determination before a filter test is initiated. Expressed as a percentage of the cubic feet of air that would pass through the filter if the fan operated at continuous fan CFM for 30 days.
UV lamp operation detection	Default: ON. Options are either ON or OFF.
Filter Life	Provides percentage of remaining filter life. This is for display purposes only and cannot be changed.
Last replacement date for filter	Date last filter reset was accomplished. This is for display purposes only and cannot be changed
Purifier life	Provides percentage of remaining purifier life. This is for display purposes only and cannot be changed
Last replacement date for purifier	Date last purifier insert reset was accomplished. This is for display purposes only and cannot be changed

- Reset **PureAir S** will reset all **PureAir S** parameters back to factory defaults.
- Reset purifier will reset it to 100%. This is usually accomplished after the purifier insert has been replaced.
- Reset filter will reset it to 100%. This is usually accomplished after the air filter has been replaced.

Add/Remove Equipment

Here additional non-communicating equipment can be added. Type of equipment that are supported are fresh air damper, 1 or 2 speed HRV/ERV, By-pass (24VAC Humidifier, Humiditrol, and auxiliary dehumidifier.

Add Device

Smart Devices Network

The Lennox Smart Devices Network can only be created by using the **Lennox® Smart Technician Application**.

Managing Smart Devices

Smart devices can be added, replace and removed. Please refer to the Installation and Setup Guide for each product for procedures on how to add, replace or remove these smart devices.

Lennox Smart Room Sensor

Table 14. Lennox Smart Room Sensor (SRS)

Parameter	Description
Sensor Name	This could be the default sensor name given when the sensor was added. This field also allows the sensor to be renamed.
Device Type	Sensor
Sensor Status:	
Battery	This is the battery available power percentage.
RSSI Signal Strength	This indicates the Bluetooth signal strength between the sensor and the S40 thermostat or wireless extender if used.
Sensor Information:	
Model Number	Model number of device.
Serial Number	Serial number.
Firmware Version	Current firmware version of the sensor.

IMPORTANT

The Lennox Smart Room Sensor is not compatible with systems using the Lennox Smart Zoning System (iHarmony) installed.

Lennox Smart Air Quality Monitor

Table 15. Lennox Smart Air Quality Monitor

Parameter	Description
Monitor Name	This could be the default Lennox Smart Air Quality Monitor name given when the monitor was added. This field also allows the monitor to be renamed.
Device Type	Monitor
Level of Indoor Air Cleanliness	Status types that can be displayed are High, Medium and Basic (Most Economical)
Monitor Status	
RSSI Signal Strength	This indicates the Bluetooth signal strength between the monitor and the S40 thermostat or wireless extender if used.
Monitor Information	
Model Number	Model number of device.
Serial Number	Serial number.
Firmware Version	Current firmware version of the sensor.

Lennox Wireless Extender

Table 16. Lennox Wireless Extender

Parameter	Description
Extender Name	This could be the default extender name given when the device was added. This field also allows the extender to be renamed.
Device Type	Extender
Monitor Status	
RSSI Signal Strength	This indicates the Bluetooth signal strength between the monitor and the S40 thermostat or wireless extender if used.
Extender Information	
Model Number	Model number of device.
Serial Number	Serial number.
Firmware Version	Current firmware version of the sensor.

Reset

Table 17. Reset

Parameter	Description
Restart thermostat	Restarts the thermostat.
Re-configure System	Re-configure HVAC system.
Reset HVAC Equipment	Resets all HVAC equipment.
Factory Reset Thermostat	Resets thermostat to factory default settings.
Factory Reset thermostat	Resets thermostat parameters back to factory default.

Information

The dealer information screen will appear. The next screen will be for dealer information. Here either the dealer ID or phone number can be added. Once the system is connected to the Internet, the remaining information is automatically populated. Not all information for this screen will be viewable. Touch and hold and then drag up to access the remaining information on the screen.

Information Required: Dealer ID and / or dealer phone number. Information that can be manually entered is name, email website, dealer address which includes address 1, address 2, city state and zip/postal code. Once

completed, touch the left arrow at the top left side of screen to return to the Dealer Control Center.

IMPORTANT

Adding dealer information will ensure the thermostat is associated with your LennoxPros account when connecting to the Lennox server.

Information Pop-Up Screen: If the dealer ID or phone number is not provided, a warning screen will appear. The warning screen will provide information on the limitation imposed on the system if this information is missing. Touch no to return to the above screen to complete the information requested or press yes to continue.

Tests

Verify Airflow Per Zone is the first screen to appear under this selection. If no zoning is installed then this screen will not appear during commissioning. If zoning equipment is detected by the system then zones 1 through 4 will be listed. These screens allow for verification and modification of CFMs for blower, heating and cooling circulation. Touch continue to proceed to the next screen.

Select **Test Mode** is the next screen to appear. Your options are **automated tests** or **manual tests**. Select the desired option and select **apply**.

- **Automated Tests:** Select this options and the next screen will allow you to select the specific tests available for your hardware configuration. The test are automatic and no installer / service technician's attendance is required. When the automatic testing is complete the system returns to the consumer home screen. A updated installation report is generated and available in Lennox Pros under the Homeowners account.
- **Manual Test:** Depending on hardware present, various tests are available. By default all items to be tested are enabled. Selecting a specific test will deselect the item. When a specific set of tests are completed the results will be displayed on the screen next to the tested item. Touch continue to proceed to the next set of test items. Once all tests are completed press done to return to the touch tests to run screen. Touch the left arrow at the top left side of screen to return to the Dealer Control Center

Diagnostics

This screen allows the installer to test all major communicating components of the system indoor unit (air handler or furnace), outdoor unit (air conditioner or heat pump) and zoning control (if applicable). Pressing the stop diagnostics button will pause the diagnostic function.

Touch the left arrow at the top left side of screen to return to the Dealer Control Center.

Installation Report

This section lists information on Installer and customer information. In addition, installation date which included current date, time, outdoor and indoor temperatures and indoor humidity. The communicating equipment automatically found will also be listed in this section. Information listed for equipment is equipment name, model number, serial number and firmware version.

Connect to Lennox® Smart Technician App

This will allow the service technician to connect the **Lennox® Smart Technician Application** for servicing purposes. Follow the on-screen instructions to pair the service app to the thermostat. The provided Quick Start Guide has a QR code that can be scanned to download the **Lennox® Smart Technician App** to your mobile device.

Displaying Outdoor Temperature (Sensor) and Indoor Humidity on the Thermostat Home Screen

Displaying the Outdoor Sensor Temperature on the Home Screen

An outdoor temperature sensor is provided in all Lennox communicating outdoor units. To display the outdoor temperature on the home screen of the Thermostat, you can enable this feature under the dealer control center. Use the following procedure to enable the outdoor temperature sensor display.

1. Select **Menu** and then select **Settings**.
2. Select **Advanced Settings** and then select **View Support Service Control Center**.
3. Select **Equipment Settings** and then select **Thermostat**.
4. Scroll down the list and select **Outdoor Temperature Source** and select **Sensor**.
5. Select **< Back** and the **Exit**.
6. Select **Menu > Display Settings**.
7. Select **Homescreen** and set **Outdoor Weather** to **On**
8. Select **Home icon** to return to the home screen.

Displaying the Indoor Humidity on the Home Screen

To enable the Indoor Humidity Display on the Home screen use the following procedure:

1. Select **Menu** and then select **Display Settings**.
2. Select **Homescreen** and set **Indoor Humidity** to **On**
3. Select **Back** and then select **Home** to return to the home screen.

NOTE: By default the Humidity Display is set to ON.

Specific Configurations

Dehumidification Settings

All controls for dehumidification are listed at **Menu > Settings > Humidity**. Under **Humidity**, select **dehumidify** to enable dehumidification. By default it is **disabled**.

When dehumidify is enabled, the options are as follows and are dependent on equipment type and accessory installed.

Dehumidification Setting Options

- **Basic** — Recommend when the air outside is not too humid.
- **Max** —
 - » Single and Two-Stage Outdoor Units or Variable Capacity outdoor units without a Discharge Air Temperature Sensor (DATS) Installed. Recommend when outdoor air is excessively humid. May cool your home below the set temperature.

NOTE: Recommend use of DATS catalog number 88K38 when variable capacity outdoor units are used.

- » Variable Capacity Outdoor Units with DATS installed. Recommended when outdoor air is excessively humid. Adjusts cooling based on duct sensor data. May cool your home below the set temperature.
- **Climate IQ (Auto)** — Automatically adjusts fan speeds and cooling power based on local climate conditions, using Climate IQ technology. May cool your home below the set temperature.

Overcooling

Slide bar adjust with a range of 0°F to 4°F (-17.8 to -15.5°C). Only available when Max or Climate IQ is selected.

Dehumidification Set Point

Slide bar adjust with a range of 40% to 60%.

Advanced Dehumidification Descriptions

See table 1 for detail information concerning system operations when using Normal, Max or Climate IQ settings.

Table 18. Dehumidification Control Modes of Operations

Mode of Operation	Option	Description
Dehumidification Only	Normal	Both Staged and Variable Capacity Outdoor Units: Dehumidifies while servicing a cooling demand and will not over cool. The overcooling slider is hidden from the user. Variable capacity units use the “comfort” table to run the system, regardless of the presence of a discharge air temperature sensor (DATS).
	Max	<p>Staged Outdoor Unit:</p> <p>If at the start or during a cooling call, the humidity is above the relative humidity set point then the unit dehumidifies during the cooling demand. If at the time the cooling call terminates, the humidity demand is not satisfied, overcooling will occur up to the overcooling slider setting in an attempt to satisfy the dehumidification demand. Once the room temperature reaches the over cooling set point. If the system still has a dehumidification demand, the system keeps using the over cooling set point as its operating cooling set point (will not wait for the temperature to rise to the normal cooling set point to run again) until the dehumidification demand is satisfied</p> <p>Variable Capacity Outdoor Unit:</p> <p>These units work as like staged units and if a discharge air temperature sensor (DATS) sensor is installed, the DAT PI setting is used to control the compressor speed to maintain a cold coil for optimized dehumidification. If a DATS is not installed, the system runs using the outdoor unit’s “comfort” tables during dehumidification.</p>
Dehumidification Only	Available only with Max and Climate IQ (Auto)	<p>Staged Outdoor Unit:</p> <p>At the end of a cooling call, if the humidity is above the set point by a certain amount (Basic to Precision Threshold parameter), then overcooling to the overcooling slider setting occurs to satisfy the dehumidification demand. Once the room temperature reaches the overcooling set point, if the system still has a dehumidification demand, the system keeps using the over cooling set point as its operating cooling set point (will not wait for the temperature to rise to the normal cooling set point to run again) until the dehumidification demand is satisfied.</p>

Table 18. Dehumidification Control Modes of Operations

Mode of Operation	Option	Description
Dehumidification Only	Available only with Max and Climate IQ (Auto)	<p>Variable Capacity Outdoor Unit:</p> <p>If at the start or during a cooling call, the humidity level is below the relative humidity set point by more than 10%, then the mode becomes “Dry” such that the blower CFM is increased to the “Dry” table setting.</p> <ul style="list-style-type: none"> • If a cooling call starts with the humidity level below the relative humidity set point, or if during a cooling call, the humidity level is between the dehumidify off relative humidity point and the relative humidity set point -10, then standard cooling runs to satisfy the cooling demand, without any added dehumidification. • If at the start or during a cooling call, the humidity is above the relative humidity set point then the unit dehumidifies during the cooling demand. If at the time the cooling call terminates, the humidity is above the Basic to Precision Threshold then overcooling will occur up to the slider setting in an attempt to satisfy the dehumidification demand. Once the room temperature reaches the over cooling set point, if the system still has a dehumidification demand, the system keeps using the over cooling set point as its operating cooling set point (does not wait for the temperature to rise to the normal cooling set point to run again) until the dehumidification demand is satisfied. • The Basic to Precision Threshold is a parameter with the following properties: Definition: Relative humidity amount above the relative humidity set point where over cooling will occur to dehumidify. Default: 4, Min: 0, Max: 10, Inc: 1 • Variable capacity units use the “comfort” table to run the system, regardless of the presence of a DATS. <div data-bbox="409 940 969 1017"> <p>overcooling</p> </div> <div data-bbox="409 1053 969 1130"> <p>dehumidification set-point</p> </div>

1 All Lennox variable capacity outdoor units.

NOTE - The above information is applicable only for non-zoning systems. There is no dehumidification capability in zoning systems.

Lennox Smart Zoning

This optional equipment is compatible with the following Lennox equipment:

- Lennox communicating variable speed or variable capacity (variable capacity) indoor and two-stage or variable capacity (modulating) outdoor units.
- Lennox communicating variable speed indoor unit and communicating or non-communicating (conventional) single-stage outdoor unit (two zones maximum supported).
- Lennox communicating variable speed indoor unit and communicating or non-communicating (conventional) two-stage outdoor unit (four zones maximum supported).
- Parameter settings are listed in “Table 12. Zoning Control Parameters” on page 46.
- Wiring connections are all Lennox accessories in the installation instruction for the specific product.

! IMPORTANT

The Lennox Smart Room Sensor is not compatible with systems using the Lennox Smart Zoning System (formerly know as iHarmony) installed.

PureAir S

This optional equipment supports the following features:

- 4-wire connection to Lennox communicating indoor unit control
- Using sensors to:
 - » Automatically detect dirty air filter
 - » Display air filter life percentage
 - » Monitor UVA lamp operational state (On or Off).
 - » Display UVA lamp life percentage
- Parameter settings are listed in “Table 13. PureAir S Parameters” on page 46.
- Applicable alarms for PureAir operations are listed in “Alert Codes” on page 55.

Ventilation (ERV, HRV and Fresh Air Damper)

NOTE: ERV/HRV and Fresh Air Damper operations will required a Equipment Interface Module (EIM), catalog number 22X18.

This optional equipment is designed to provide fresh air while exhausting an equal amount of stale air.

NOTE: When using a fresh air damper, a field-provided 24VAC transformer (Lennox Catalog Number 10P17) is required.

For complete installation and setup information for ventilation equipment, see Equipment Interface Module (EIM) (22X18) Installation and Setup Guide (507240-0x) for complete details.

Ventilation Rates

The S40 ventilation function is only a turn on - turn off feature. All CFMs must be adjusted from the HRV/ERV unit. The ventilation function can be controlled by outdoor temperatures and by timers in the thermostat. The ventilation feature can also control 1 and 2 stages of ventilation operation.

Thermostat ventilation CFM parameters are to be adjusted only after the HRV/ERV set up is completed and the CFMs are known. Once the thermostat's CFMs are adjusted they are used with the thermostat's timer algorithm to determine how long to run the HRV/ERV and to change from low to high speed if a 2-stage HRV/ERVs.

Energy Recovery Ventilator (ERV)

The ERV unit is equipped with an enthalpic core. This device is designed for use in warm, humid climates with heavy air conditioning loads. The ERV unit transfers both sensible (temperature) and latent (moisture) heat from incoming fresh air to the stale air as it is being exhausted; thus, reducing the air conditioning load.

Heat Recovery Ventilator (HRV)

The HRV unit is equipped with an aluminum core. The device uses the stale air that is being exhausted to condition the fresh air as it is being brought in.

Lennox models are all non-communicating equipment and can be added during the commissioning procedure (see "Alert Codes" on page 55).

Parameter settings and descriptions are listed in "Table 6. Thermostat Parameters" on page 31. The table below list which parameters are available for the Fresh Air Damper, ERV and HRV equipment.

Fresh Air Damper

This option is used to control a damper connecting outside air to the return plenum of the system. When a fresh air damper style of ventilation is added to the system, and ventilation is required, the ventilation demand is serviced by energizing one relay to close or open the relay contacts connected to the fresh air damper and commanding the blower to run at a rate of at least the continuous fan speed.

The parameter Fresh Air Damper Ventilation CFM represents the CFM of the air drawn through the fresh air damper while the system runs the indoor blower at the continuous fan speed for non-zoned systems, and the lowest zone CFM (continuous fan, heating, or cooling) for zoned applications. All calculations used to determine the ventilation volume requirement and the amount of ventilation air delivered use this number regardless of the actual fan speed.

Zoning Application

- When ventilation is demanded in zoned applications without conditioning calls, the fresh air damper will open and the blower will run at the lowest set zone CFM referred to above.
- Ventilation while a zone is being conditioned is serviced simply by opening the fresh air damper while the zone system conditions the zone.
- The system keeps track of the amount of ventilation delivered in the same manner as any single speed HRV or ERV.
- When the time required to satisfy the ventilation time requirement using the fresh air damper ventilation rate is greater than or equal to the time remaining in the ventilation time block, then ventilation is initiated and continues until the ventilation time requirement is satisfied.

Operation of Fresh Air Dampers with Environmental Overrides

- When the Non-ASHRAE Compliant mode is selected (Timed), the system first checks for the outdoor temperature and dew point to be within the set parameter range before allowing ventilation to occur.
- When the ventilation changes states (on/off) due to an environmental override, it will remain in that state for a minimum of 10 minutes before again changing states due to an environmental override.
- Operation is otherwise the same as the ASHRAE compliant method.

Ventilation Control Modes

Thermostat ventilation CFM parameters are to be adjusted only after the HRV/ERV set up is completed and the CFMs are known. Once the thermostat's CFMs are adjusted they are used with the thermostat's timer algorithm to determine how long to run the HRV/ERV and to change from low to high speed if a 2-stage HRV/ERVs.

Table 19. Ventilation Control Modes

Ventilation Control Mode	Fresh Air Damper	1 Speed HRV	2 Speed HRV	1 Speed ERV	2 Speed ERV
Timed					
Ventilation Minutes Per Hour (0 to 60 min., default is 20 min.)	X	X	X	X	X
Ventilation Rate (20 to 500 cfm, default is 130 cfm) (Shown only for single speed ERV or HRV)	X	X		X	
Ventilation Rate for Low Speed (10 to 200 cfm, default is 50 cfm) (Shown only for two speed ERV or HRV)			X		X
Ventilation Rate for High Speed (20 to 500 cfm, default is 130 cfm) (Shown only for two speed ERV or HRV)			X		X
Ventilation High Outdoor Temperature Limit (60 to 115°F, default is 100°F)	X	X	X	X	X
Ventilation Low Outdoor Temperature Limit (-20 to 55°F, default is 0°F)	X	X	X	X	X
Ventilation High Outdoor Dew Point Limit (45 to 80°F, default is 55°F)	X	X	X	X	X
ASHRAE (62.2)					
<i>NOTE: In this mode the thermostat can assist the installer by validating the ventilation CFMs are capable of meeting the ASHRAE required ventilation volumes, but the thermostat has no ability to control CFM from the HRV/ERV.</i>					
Ventilation Rate (20 to 500 cfm, default is 130 cfm)	X	X		X	
Ventilation Rate for Low Speed (10 to 200 cfm, default is 50 cfm)			X		X
Ventilation Rate for High Speed (20 to 500 cfm, default is 130 cfm)			X		X
ASHRAE Compliance Check	NO	YES	YES	YES	YES
ASHRAE Infiltration Credit (0 to 200 cfm, default is 0 cfm)	X	X	X	X	X
ASHRAE House Floor Area Serviced by this Ventilator	X	X	X	X	X
ASHRAE Number of Bedrooms	X	X	X	X	X
Ventilation Outdoor Condition Override - Enabled					
Ventilation High Outdoor Temperature Limit (60 to 115°F, default is 100°F)	X	X	X	X	X
Ventilation Low Outdoor Temperature Limit (-20 to 55°F, default is 0°F)	X	X	X	X	X
Ventilation High Outdoor Dew Point Limit (45 to 80°F, default is 55°F)	X	X	X	X	X

Notifications (Service and Alert Codes)

These screens provide information on active notifications and previously cleared notifications. When selecting either a cleared or active notification a brief description and alert code will be displayed. Notifications are categorized by system, indoor unit (air handler or furnace), outdoor unit (air conditioner or heat pump), zoning control (if installed) and thermostat.

ALERT CODE PRIORITY TYPES AND NOTIFICATION OPTIONS

To expand a specification notification to access a more detail description of the alert code, press the down arrow to expand the description.

Table 20. Alert Code Priority Condition Visibility

Alert Priority	Alert Priority Description n	Notifications Displayed or Email Notifications Sent						
		Displayed for Homeowner on Thermostat	Displayed for Dealer on Thermostat	Lennox Home Application	Lennox® Smart Technician Application**	LennoxPros Service Dashboard**	Homeowner Emailed*	Dealer Emailed
Service Urgent	Your system is in a No Heat/ No Cool or not operating. Dealer service call is needed to get the system running.	√	√	√	√	√	√	√
Service Soon / Service Urgent	This alert priority indicates that the system will likely recover on its own and no interaction is necessary. Typically, either after a specific timer period or a specific number of instances, some Service Soon alerts will escalate to Service Urgent .	X	√	X	√	√	X	X
Service Soon	System is not reaching set point or is partially operating. A Dealer will need to service it with 24-48 hours.	X	√	X	√	√	X	X
Maintenance	Maintenance alerts are those intervals you put in the thermostat as reminders to change filters, replace UV lamps, tune up systems.	√	X	√	X	√	X	X
Information Only-Dealer	This alert priority is for information and is directed to the dealer.	X	√	X	√	X	X	X

* For homeowner to receive email notifications, email updates has to be enabled. From the home screen, go to **menu > user account > Email updates** and set to **ON**.

** For dealers to receive service alerts and service alert emails the feature needs to be enabled by the homeowner. From the home screen, go to **menu > user account > Dealer Email updates** and set to **ON**.

Soft Disable

Soft disabling is when the Lennox communicating thermostat finds an unknown control on the communication bus. The thermostat sends the unknown control a message to go into soft disable mode until the component is properly configured or removed.

Sometimes soft disable will occur when a control is being replaced. Reconfiguring the system should resolve this issue.

The Lennox communicating thermostat will not show a alert code for a soft disabled control. When soft disabling occurs only the control that has been disabled will display the blinking LED status or seven-segment display indicator. Refer to the device's installation and setup guide for further guidance.

The thermostat control with the soft disable state will indicate so as follows:

- On air handler, integrated furnace and outdoor controls, the soft disable state is display by double horizontal lines on seven segment display.
- On Lennox damper control module and EIM the green LED will blink 3 seconds on and 1 second off.

Possible Cause

- Soft disable may occur when a control has been replaced. Reconfiguring the system should resolve this issue.
- Sometimes Lennox communicating thermostat detects a new device or an existing device or a device on the system that is not communicating with the thermostat. If this occurs, an alert code 10 is activated and the thermostat sends a soft disable command to the offending device on the communication bus (outdoor control, IFC, AHC, EIM, or damper control module).

Re-Configure System

Use the following procedure if any controls are displaying the soft disable indicator:

1. Confirm proper wiring between all devices such as thermostat and thermostat.
2. Cycle power.
3. Go to the **Menu > Settings > Advanced Settings > View Support Service Control Center**.
4. Select **Equipment Settings**.
5. Select **Reset**.
6. Select **Re-Configure System**.

NOTE: Running the re-configuration utility will not affect settings for non-communicating equipment already configured and other custom settings.

7. Select **Yes** to continue.
8. The thermostat will reboot and start through the system commissioning procedure.

Service Notification Alert Codes

The following are service notification alert codes.

Table 21. Service Alert Notification Codes

Service Alert Code	Function
3000	Filter 1
3001	Filter 2
3002	Humidifier pad
3003	UV Light
3004	Maintenance
3005	PureAir Maintenance

Table 22. Lennox® S40 Smart Thermostat Alert Codes and Troubleshooting

E2A=Errors to Action, GF= Gas Furnace, AH=Air Handler, IU=Indoor unit (GF or AH), HP=Heat Pump, AC=Air Conditioner, OU=Outdoor Unit (AC or HP), PA=Pure Air S, ZA=Zone system, SRS=Smart Room Sensor, TS=Thermostat , IAQ- IAQ Monitor and WE=Wi-Fi Extender

Alert Code	Inverter Flash Code	Priority Condition	Actual Displayed Alert Text Under dealer control center > Notifications	Component or System Operational State and Troubleshooting Tip	How to clear alert code
10		Service Urgent	Unknown Device Detected	<p>The thermostat when NOT in commissioning mode has detected an unknown device. Typically the thermostat will send a command to the unknown device and place the device into a soft disable state. The soft disable control will indicate so as follows:</p> <ul style="list-style-type: none"> • On air handler, furnace and outdoor controls, the soft-disabled state is displayed by double horizontal lines on seven-segment display. • On the damper control module, the green LED will flash 3 seconds on and 1 second off. • On the equipment interface module, the green LED will flash 3 seconds on and 1 second off. • A new communicating device has been added to the system since the original configuration setup was completed. • Go to Menu > Settings > Advanced Settings > View Support Service Control Center > Equipment Listing > Reset and select Reset All Equipment. This will allow the system to auto-detect any Lennox communicating devices attached. 	Clear alert code by reconfiguring the system.
11		Service Urgent	Missing Device	<p>The thermostat cannot find a previously installed system component.</p> <ul style="list-style-type: none"> • Check all system components (devices) connections to make sure they are Lennox communicating compatible. • Cycle system power. • If problem persists, then check all system components (devices) connections to make sure they are Lennox communicating compatible. • Go to Menu > Settings > Advanced Settings > View Support Service Control Center > Equipment Listing > Reset and select Reset All Equipment. This will allow the system to auto-detect any Lennox communicating components attached. 	Cycle system power, and If problem persists then clear by reconfiguring the system.
12		Service Urgent	Indoor Unit Not Detected	<p>Thermostat did not find an indoor unit. Make sure there is an Lennox communicating indoor unit on the system.</p> <ul style="list-style-type: none"> • Check for voltage and missing component. • Check R, i+, i- and C connections at mag-mount or subbase, thermostat and all attached communicating components. • Ohm wires for electrical continuity. • Cycle power to both indoor unit first and then thermostat. • Verify that equipment interface module (if applicable) is configured as either an air handler or furnace when used with a non-communicating indoor unit. • Go to Menu > Settings > Advanced Settings > View Support Service Control Center > Equipment Listing > Reset and select Reset All Equipment. This will allow the system to auto-detect any Lennox communicating components attached. • Replace indoor unit control if there is no response. 	Automatically clears when the system detects that the issue no longer exists.

Table 22. Lennox® S40 Smart Thermostat Alert Codes and Troubleshooting

E2A=Errors to Action, GF= Gas Furnace, AH=Air Handler, IU=Indoor unit (GF or AH), HP=Heat Pump, AC=Air Conditioner, OU=Outdoor Unit (AC or HP), PA=Pure Air S, ZA=Zone system, SRS=Smart Room Sensor, TS=Thermostat , IAQ- IAQ Monitor and WE=Wi-Fi Extender					
Alert Code	Inverter Flash Code	Priority Condition	Actual Displayed Alert Text Under dealer control center > Notifications	Component or System Operational State and Troubleshooting Tip	How to clear alert code
13		Service Urgent	Duplicate Comfort Sensor ID	<p>Thermostat found more than one outdoor unit, or more than one indoor unit, or more than one thermostat connected to the system. Thermostat will display the message “Too Many Devices of the Same Type”.</p> <ul style="list-style-type: none"> • Check wiring and remove duplicate equipment. • Go to Menu > Settings > Advanced Settings > View Support Service Control Center > Equipment Listing > Reset and select Reset All Equipment. This will allow the system to auto-detect any Lennox communicating components attached. 	Automatically clears when the system detects that the issue no longer exists.
14		Service Urgent	Too Many Devices of the Same Type	<p>The thermostat found more than one thermostat, indoor or outdoor unit on the system.</p> <ul style="list-style-type: none"> • Check wiring and remove duplicate equipment. • Go to Menu > Settings > Advanced Settings > View Support Service Control Center > Equipment Listing > Reset and select Reset All Equipment. This will allow the system to auto-detect any Lennox communicating components attached. 	Automatically clears when the system detects that the issue no longer exists.
15		Information Dealer Only	Parameter Mismatch Detected	Incorrect parameter settings detected. Dealer would need to re-set the system and start configuration again.	Automatically clears once proper system configuration is completed.
20		Service Urgent	Protocol Upgrade Required	The thermostat cannot work with one of the system devices because the thermostat firmware needs to be updated first.	Update thermostat firmware.
21		Service Urgent	Incompatible Equipment Detected	Equipment is trying to be utilized that is not compatible with other system components, such as a single-stage non-variable speed motor furnace with a variable capacity outdoor unit.	Use compatible equipment.
29		Service Urgent	Over Temperature Protection	<p>The thermostat is reading an indoor temperature that is higher than 90°F (factory default). The thermostat will not allow any heating operation to begin until it senses an indoor temperature lower than 90°F. Indoor temperature rose above 90°F during a heating or cooling demand.</p> <ul style="list-style-type: none"> • Heating operation is not allowed. • Check to ensure that heating equipment is not stuck ON (reversing valve, etc.) • Check the accuracy of the thermostat temperature sensor. • Select cooling system mode to cool the indoor space below 90°F. 	Automatically clears when the system detects that the issue no longer exists.
30		Service Soon / Service Urgent	Low Temperature Protection	<p>The thermostat will not allow any cooling operation to begin until it senses a temperature higher than 40°F.</p> <ul style="list-style-type: none"> • Cooling operation is not allowed. • Check to ensure that cooling equipment is not stuck ON. • Check accuracy of the thermostat temperature sensor. • Select heating system mode to heat the indoor space to above 40°F. 	Automatically clears when the system detects that the issue no longer exists.
31		Service Urgent	Lost communication with Device	<p>The applicable system component (indoor, equipment interface, damper control module or outdoor unit) has not communicated with thermostat for more than three minutes.</p> <ul style="list-style-type: none"> • Check connections and voltages. • Ohm wires for electrical continuity. • If float switch is installed on air handler drain pan, check condensate line to ensure it is not clogged and tripping the float switch connected in series with R terminal. • Check to see if freezestat is installed. 	If fault persists, then cycle power. Fault clears after communication is restored.

Table 22. Lennox® S40 Smart Thermostat Alert Codes and Troubleshooting

E2A=Errors to Action, GF= Gas Furnace, AH=Air Handler, IU=Indoor unit (GF or AH), HP=Heat Pump, AC=Air Conditioner, OU=Outdoor Unit (AC or HP), PA=Pure Air S, ZA=Zone system, SRS=Smart Room Sensor, TS=Thermostat , IAQ- IAQ Monitor and WE=Wi-Fi Extender

Alert Code	Inverter Flash Code	Priority Condition	Actual Displayed Alert Text Under dealer control center > Notifications	Component or System Operational State and Troubleshooting Tip	How to clear alert code
32		Information Only-Dealer	Device Resetting	<p>The applicable system component (device) is resetting itself. This issue may occur during a power outage or power fluctuation in the system. If persistent or if it coincides with the system operations then proceed with the following troubleshooting steps.</p> <ul style="list-style-type: none"> • Check the power connections. • Check the amperage draw at the transformer (possible overloaded). • Check 24VAC voltage at the system component (device). • If the fault persists after checking the connections, replace the applicable control. 	To clear the alert code, go to menu > settings > advanced settings > view dealer control center > notifications and select the alert code and press the clear button.
34		Service Urgent	Must Program Unit Capacity For Device	<p>The thermostat does not know the capacity (tonnage) of the indoor or outdoor unit. The applicable system component is missing the programmed unit capacity.</p> <ul style="list-style-type: none"> • Remove power to thermostat before programming the unit control. • Go to applicable unit control and program the unit capacity manually (see the unit installation instruction for configuration instructions). • Once configuration is complete then reconnect thermostat wires. • Go to Menu > Settings > Advanced Settings > View Support Service Control Center > Equipment Settings > Reset and select Reset HVAC equipment. This will allow the system to auto-detect any Lennox communicating components attached. 	Automatically clears when the system detects that the issue no longer exists.
35		Service Urgent	Incorrect Operation Of Device	<ul style="list-style-type: none"> • Message sent by thermostat to unit after more than 15 minutes asking for initiating heating or cooling with no response from unit. • Message sent by thermostat to unit after more than 15 minutes asking for termination of heating or cooling with no response from unit. <p>Result</p> <p>A communicating device in the system has been disabled due to a fault/lockout code in the unit's control. Another possible cause is electrical noise interference affecting the communicating system when the compressor contactor coil is energized.</p> <p>Corrective Action:</p> <ul style="list-style-type: none"> • Single and Two-stage units only: Communicating system: Wire a transient voltage suppressor in parallel with the compressor contactor coil terminals on the outdoor unit. • Non-communicating outdoor unit: Wire transient voltage suppressor in parallel with compressor contactor coil or across the Y1 and C terminals on the indoor control board. <p>NOTE: See service and application note IAQ-10-01 for further details.</p> <p>Transient Voltage Suppressor Part information: Made by Little Fuse, part number 5KP43CA bidirectional Transorb aka TVS Diode.</p>	
36		Service Urgent	Heating when Not Requested	<p>The system has been heating for at least 15 minutes without a demand for heating.</p> <ul style="list-style-type: none"> • Run the system in diagnostic mode and verify that it matches actual equipment operation. Go to Menu > Settings > Advanced Settings > View Support Service Control Center and select Diagnostics and press the start diagnostics button. • Check for other alert codes that may be preventing the system from operating as expected. • Check all heating equipment to determine cause of heating demand. • Recycle power. 	Automatically clears when the system detects that the issue no longer exists.

Table 22. Lennox® S40 Smart Thermostat Alert Codes and Troubleshooting

E2A=Errors to Action, GF= Gas Furnace, AH=Air Handler, IU=Indoor unit (GF or AH), HP=Heat Pump, AC=Air Conditioner, OU=Outdoor Unit (AC or HP), PA=Pure Air S, ZA=Zone system, SRS=Smart Room Sensor, TS=Thermostat , IAQ- IAQ Monitor and WE=Wi-Fi Extender

Alert Code	Inverter Flash Code	Priority Condition	Actual Displayed Alert Text Under dealer control center > Notifications	Component or System Operational State and Troubleshooting Tip	How to clear alert code
37		Service Urgent	Cooling when not Requested	<p>The system has been cooling for at least 15 minutes, without a demand for cooling.</p> <ul style="list-style-type: none"> Run the system in diagnostic mode and verify that it matches actual equipment operation. Go to Menu > Settings > Advanced Settings > View Support Service Control Center and select Diagnostics and press the start diagnostics button. Check for other alert codes that may be preventing the system from operating as expected. Check all cooling equipment to determine cause of cooling demand. Recycle power. 	Automatically clears when the system detects that the issue no longer exists.
38		Service Urgent	Not Heating when Requested	<p>The system has not been able to turn on the heating for more than 45 minutes.</p> <ul style="list-style-type: none"> The system will go off-line for 60 minutes and will attempt to restart itself. Run the system in diagnostic mode and verify that it matches actual equipment operation. Go to Menu > Settings > Advanced Settings > View Support Service Control Center and select Diagnostics and press the start diagnostics button. Check for other alert codes that may be preventing the system from operating as expected. Check all heating equipment to determine cause. Recycle power. 	Automatically clears when the system detects that the issue no longer exists.
39		Service Urgent	No Cooling when Requested	<p>The system has not been able to turn on the cooling for more than 45 minutes.</p> <ul style="list-style-type: none"> The system will go off-line for 60 minutes and will attempt to restart itself. Run the system in diagnostic mode and verify that it matches actual equipment operation. Go to Menu > Settings > Advanced Settings > C and select Diagnostics and press the start diagnostics button. Check for other alert codes that may be preventing the system from operating as expected. Check all cooling equipment to determine cause. Recycle power. 	This alert code will automatically clear when the system detects the issue no longer exists.

Table 22. Lennox® S40 Smart Thermostat Alert Codes and Troubleshooting

E2A=Errors to Action, GF= Gas Furnace, AH=Air Handler, IU=Indoor unit (GF or AH), HP=Heat Pump, AC=Air Conditioner, OU=Outdoor Unit (AC or HP), PA=Pure Air S, ZA=Zone system, SRS=Smart Room Sensor, TS=Thermostat , IAQ- IAQ Monitor and WE=Wi-Fi Extender

Alert Code	Inverter Flash Code	Priority Condition	Actual Displayed Alert Text Under dealer control center > Notifications	Component or System Operational State and Troubleshooting Tip	How to clear alert code
40		Information Only-Dealer	HP Heating Lockout.	<p>The heat pump could not increase the room temperature 0.5°F towards the set point in 30 minutes.</p> <p>Gas Furnace Heating</p> <p>In order to use the gas furnace as a primary heating source (not defrost tempering) when the outdoor temperature is between the high and low balance points, the heat pump:</p> <ul style="list-style-type: none"> • Must be used for a minimum of 30 minutes and the temperature in the zone not increase by more than 0.5°F. • Has not gone into defrost in the 30 minute period. <p>The default for HP Heating Lockout Time default is 120 minutes and will lock the heat pump off when the outdoor temperature is above the high balance point. Selectable range is 60 to 240 minutes.</p> <ul style="list-style-type: none"> • Go to Menu > Settings > Advanced Settings > Menu > Settings > Advanced Settings > View Support Service Control Center and select Equipment Listing > Thermostat and located HP Heating Lockout Time to verify the lockout time setting. • Check air flow to the zones or zones. • Check discharge air temperatures. • Check calibration of room thermostat. <p>Outdoor Unit and Zoning</p> <p>When the heat pump could not get a zone thermostat to progress 0.5°F towards the set point in 30 minutes the system will lock out the heat pump and switch to the secondary heat source. (Electric heat or if in dual fuel applications the furnace will be used and the system put in heat pump heating lockout timer) default is 120 minutes. It will lock the heat pump off and the gas furnace will finish the heating cycle.</p> <p>Set the low balance point and high balance point as close together as possible. (This is a 3°F difference – Example: set high balance point at 25°F and low balance point would set at 22°F). Below the low balance point, the furnace will heat the home / between the low and high balance point, the heat pump and furnace will heat the home. I when the outdoor temperature is above the high balance point, the gas furnace is locked out and all the heat is provided by the heat pump.</p>	
41		Information Only-Dealer	Device Control Board Replaced	This alert code will appear anytime a communicating control [<i>Furnace, air handler, PureAir S, damper control module, air conditioner or heat pump</i>] is replaced in the system.	Must be cleared manually.

Table 22. Lennox® S40 Smart Thermostat Alert Codes and Troubleshooting

E2A=Errors to Action, GF= Gas Furnace, AH=Air Handler, IU=Indoor unit (GF or AH), HP=Heat Pump, AC=Air Conditioner, OU=Outdoor Unit (AC or HP), PA=Pure Air S, ZA=Zone system, SRS=Smart Room Sensor, TS=Thermostat , IAQ- IAQ Monitor and WE=Wi-Fi Extender

Alert Code	Inverter Flash Code	Priority Condition	Actual Displayed Alert Text Under dealer control center > Notifications	Component or System Operational State and Troubleshooting Tip	How to clear alert code
105		Service Soon / Service Urgent	Wiring Issue	<p>Low voltage wiring between one of the systems components has been compromised. The System component (device) is unable to communicate.</p> <ul style="list-style-type: none"> S40 - Access Dealer Control Center - Select notification icon, review alert code details to determine which device or unit's low voltage wiring is experiencing a communication issue. Review both active and cleared alerts. Wi-Fi - Press and hold the Lennox logo on bottom right of stat for 5 seconds to access the dealer control center. Follow prompts to access the "Alerts" tab. Review alert code details to determine which device or unit's low voltage wiring is experiencing a communication issue, Review both active and cleared alerts. <p>Troubleshooting: Step 1</p> <p>In most cases, issues can be resolved by taking the following actions:</p> <ul style="list-style-type: none"> Confirm all unused wires are tied together and taken back to the "C" terminal on the indoor board as shown in the installation and setup guide. See "Figure 3. Wire Termination in Communicating Systems (Electrical Noise)" on page 7 for illustration on bundling unused wires to common. Check for loose terminal connections on components (devices). Lennox recommends using a slotted screwdriver with a 3/32" (2.4 mm) tip. Check for incorrectly wired or poorly spliced connections between components. Verify that low voltage going to system components has been separated from high voltage wiring in wall, ceiling, & floor cavities. Check for proper grounding on the line voltage and low voltage wiring, transformer, and equipment. <p>If 105 Alert Code is still present after performing the actions listed above proceed to Troubleshooting: Step 2.</p> <p>Troubleshooting: Step 2</p> <ul style="list-style-type: none"> Disconnect all wiring to other components and reconnect one device at a time. Recommission system each time a device is added until wiring issue has been located. Zoning: If a zoning system has been installed and is wired directly from the thermostat to the zoning control then disconnect wiring and run control wiring from the zoning control directly to the indoor unit control. Wiring diagrams are provided in the LZSV Zoning System installation and Setup guide. Float Switch: When using a float switch, use an isolation relay between the dedicated float switch terminals as shown in "Figure 12. Lennox S40, Lennox Communicating Indoor Controls and Float Switch" on page 14. For testing purposes, remove float switch from circuit. 	Automatically clears when the system detects the issue no longer exists.

Table 22. Lennox® S40 Smart Thermostat Alert Codes and Troubleshooting

E2A=Errors to Action, GF= Gas Furnace, AH=Air Handler, IU=Indoor unit (GF or AH), HP=Heat Pump, AC=Air Conditioner, OU=Outdoor Unit (AC or HP), PA=Pure Air S, ZA=Zone system, SRS=Smart Room Sensor, TS=Thermostat , IAQ- IAQ Monitor and WE=Wi-Fi Extender

Alert Code	Inverter Flash Code	Priority Condition	Actual Displayed Alert Text Under dealer control center > Notifications	Component or System Operational State and Troubleshooting Tip	How to clear alert code
				<ul style="list-style-type: none"> Check for Inductive voltage from surrounding sources. Check each wire in AC mode to “C” on circuit board. <ul style="list-style-type: none"> > An inductive voltage of 0.3 - 0.3 VAC in not an issue. > An inductive voltage of up to 0.7 VACs can provide a moderate success rate. > An inductive voltage up to 1.2 VACs can provide an occasional success rate. > Any inductive voltage over 1.2 VAC needs to be addressed. <p>If 105 Alert Code is still present after performing the actions listed above proceed to troubleshooting Step 3.</p> <p>Troubleshooting: Step 3</p> <p>New low voltage wiring will need to be ran to the system components. There are two options for replacing low voltage wiring:</p> <ol style="list-style-type: none"> Utilizing 18/2 AWG for wires going to 24VAC (R & C) terminals and 18-22/2 AWG shielded wires going communicating terminals (+ & -). Wiring diagrams are provided in the installation manual. Utilizing 2 separate 18/2 AWG unshielded wires. One set wire to 24VAC terminals (R & C) and one set to communicating terminals (+ & -). Wiring diagrams provided in the installation manual. <p>See “Communication Wiring Options” on page 6 and 6“ for wiring diagrams.</p>	
110		Service Soon / Service Urgent	GF Low AC Line Voltage	<p>The component AC line voltage is too low. This alert code may appear during a brownout.</p> <ul style="list-style-type: none"> It may also occur when line voltage is below its designed operating value. Check and correct the power line voltage. 	Automatically clears when the system detects the issue no longer exists.
111		Service Soon / Service Urgent	GF Line Polarity Reversed	<p>The unit is reporting that its power and neutral lines are reversed.</p> <ul style="list-style-type: none"> Turn off the power to the system and correct the line power voltage wiring. System resumes normal operation five seconds after service urgent condition is recovered. 	Automatically clears when the system detects the issue no longer exists.
112		Service Soon / Service Urgent	GF No Ground Connection	<p>The reporting component cannot find earth ground. The thermostat will shut down the system.</p> <ul style="list-style-type: none"> Provide proper earth ground to the equipment. System resumes normal operation five seconds after service urgent condition is recovered. 	Automatically clears when the system detects the issue no longer exists.
113		Service Soon / Service Urgent	GF High AC Line Voltage	<p>Line voltage high (voltage higher than nameplate rating).</p> <ul style="list-style-type: none"> Provide power voltage within proper range. System resumes normal operation five seconds after service urgent condition is recovered. 	Automatically clears when the system detects the issue no longer exists.

Table 22. Lennox® S40 Smart Thermostat Alert Codes and Troubleshooting

E2A=Errors to Action, GF= Gas Furnace, AH=Air Handler, IU=Indoor unit (GF or AH), HP=Heat Pump, AC=Air Conditioner, OU=Outdoor Unit (AC or HP), PA=Pure Air S, ZA=Zone system, SRS=Smart Room Sensor, TS=Thermostat , IAQ- IAQ Monitor and WE=Wi-Fi Extender

Alert Code	Inverter Flash Code	Priority Condition	Actual Displayed Alert Text Under dealer control center > Notifications	Component or System Operational State and Troubleshooting Tip	How to clear alert code
114		Service Soon / Service Urgent	AC Line Frequency / Distortion Prob	<p>In most cases the errors will have something to do with the transformer(s) phasing, input power or output loading (amperage load). For the air handler control only, alert code 114 is generated only if the measured line frequency is below 57Hz or above 63Hz and remains out of range for 10 consecutive seconds. We count power line cycles and determine line frequency every 1 second of time based on the processor's quartz crystal oscillator. We have a fair amount of filtering on when we consider a power line cycle to have occurred, so there would have to be really bad distortion for it to count an extra cycle or miss a real cycle.</p> <p>Voltage low enough to miss a cycle would generate an alert code 115. There are lots of events, such as power utility substation switching, that could occasionally make our power line frequency off by one count. These are rare one-time events and I don't know anything other than a generator with bad frequency that could cause problems long enough to cause this alert code.</p> <p>There is a frequency / distortion problem with the power to a specific system component. This alert code may indicate transformer overloading.</p> <ul style="list-style-type: none"> • Check the voltage and line power frequency. • Check the generator operating frequency, if the system is running on back-up power. • Correct voltage and frequency problems. • System will resume normal operation five seconds after fault recovered. • All applicable system component outputs are disabled – service soon condition. • After 10 minutes, the priority condition is escalated – service urgent condition. • Damper control module will operate in central mode only until proper voltage is restored or frequency distortion is resolved • If connected to Lennox Smart Zoning system, set damper control module transformer jumper to system transformer. Check for proper wiring. Replace 40VAC furnace transformer with 70VAC transformer. Re-commission system. <p>NOTE: <i>The unitary control (outdoor unit control board) whether it is a single, two-stage or multi-stage control is not displaying alert code 114.</i></p>	
115		Service Soon / Service Urgent	Low Secondary (24VAC) Voltage	<p>24VAC power to a system component control is lower than the required range of 18 to 30VAC.</p> <ul style="list-style-type: none"> • Check and correct voltage. • Check for additional power-robbing system components (devices) connected to system. • This alert code may require the installation of an additional or larger VA transformer. • Damper control module will operate in non-zone mode until proper voltage is restored. 	Automatically clears when the system detects the issue no longer exists.
116		Service Soon	IU High Secondary (24VAC) Voltage	<ul style="list-style-type: none"> • Thermostat will display this code when 24VAC power is high (18 to 30VAC). • Will display Furnace or Air Handler High Secondary (24VAC) voltage. 	Check and correct voltage. Check for proper line voltage (120VAC, 240VAC, etc.) to equipment. Clears when control senses proper voltage.
117		Service Soon	IU Poor Ground	<p>The reporting unit has poor earth grounding.</p> <ul style="list-style-type: none"> • Provide proper grounding for the system component (device). • Check for proper earth ground to the system. • Reference Corp0123L10 for additional information 	Automatically clears 30 seconds after the issue is corrected.

Table 22. Lennox® S40 Smart Thermostat Alert Codes and Troubleshooting

E2A=Errors to Action, GF= Gas Furnace, AH=Air Handler, IU=Indoor unit (GF or AH), HP=Heat Pump, AC=Air Conditioner, OU=Outdoor Unit (AC or HP), PA=Pure Air S, ZA=Zone system, SRS=Smart Room Sensor, TS=Thermostat , IAQ- IAQ Monitor and WE=Wi-Fi Extender

Alert Code	Inverter Flash Code	Priority Condition	Actual Displayed Alert Text Under dealer control center > Notifications	Component or System Operational State and Troubleshooting Tip	How to clear alert code
120		Service Soon	Unresponsive Device	<p>There is a delay in the system component responding to the system. Typically this alert code does not cause any operational issues and will clear on its own.</p> <ul style="list-style-type: none"> • This alert code is usually caused by a delay in the outdoor unit responding to the thermostat. • Leaking voltage from strands within the bundle. <ul style="list-style-type: none"> > Land only the R wire on the R terminal to load the bundle with 24VAC. <ul style="list-style-type: none"> ▶ Typically only the R wire needs to be landed to identify if voltage is leaking. ▶ If voltage is present checking the other wires is informational only but not needed. ▶ If voltage is not present checking the other wires one at a time would be needed. > Check each loose wire in AC mode to C on circuit board. <ul style="list-style-type: none"> ▶ Good voltage is .03 -.3VAC leaking voltage is not the issue. ▶ Acceptable can be up to .7VAC with moderate success. ▶ Some units have worked with up to 1.2VAC with occasional success. ▶ Voltage over 1.2VAC needs to be addressed. 	Automatically clears after an unresponsive system component (device) responds to any inquiry.
124		Information Only – Dealer	Equipment Lost Communications	<p>The thermostat has lost communication with a system component for more than three minutes. System component has lost communication with the thermostat.</p> <ul style="list-style-type: none"> • Check the wiring connections between components. • Ohm wires. • Cycle power. • Any component that is miss-wired may cause a false component code to be shown on system component. • Disconnect all wiring to other system components and check communication one at a time. <p>NOTE: <i>When using a float switch, use isolation relay to break common wire to outdoor unit. For testing purposes, remove float switch from the circuit</i></p> <p>This alert code stops all associated system operations and waits for a heartbeat message from the system component that is not communicating.</p>	Automatically clears after communication is re-established with applicable system component (device).
125		Service Soon / Service Urgent	Control Hardware Problem	<p>There is a hardware problem on a system component control. There is a control hardware problem.</p> <ul style="list-style-type: none"> • In system using Lennox Smart Zoning, the system will remain in non-zone mode (all dampers open) for five minutes after priority condition no longer exist. • In systems using a Equipment Interface Module, remove jumper if present on indoor unit between R and W2. • In systems using a PureAir S, the pure air control board jumper selector is missing. <p>If none of the above tips are applicable, then replace the control if the problem prevents operation and is persistent.</p>	Automatically clears five minutes after the issue no longer exists.

Table 22. Lennox® S40 Smart Thermostat Alert Codes and Troubleshooting

E2A=Errors to Action, GF= Gas Furnace, AH=Air Handler, IU=Indoor unit (GF or AH), HP=Heat Pump, AC=Air Conditioner, OU=Outdoor Unit (AC or HP), PA=Pure Air S, ZA=Zone system, SRS=Smart Room Sensor, TS=Thermostat , IAQ- IAQ Monitor and WE=Wi-Fi Extender

Alert Code	Inverter Flash Code	Priority Condition	Actual Displayed Alert Text Under dealer control center > Notifications	Component or System Operational State and Troubleshooting Tip	How to clear alert code
126		Service Soon / Service Urgent	Control Internal Communication Error	<p>There is an internal hardware problem on the system component control. In addition, if you have zoning the alert code is triggered when your zone temperature is deviating away from set point persistently.</p> <ul style="list-style-type: none"> Typically the system component control will reset itself. Replace the system component (device) control if the problem prevents operation and is persistent. 	Automatically clears 300 seconds after the issue no longer exists.
130		Service Soon / Service Urgent	Configuration Jumper Missing	<ul style="list-style-type: none"> Configuration jumper missing on equipment interface module. Install the missing jumper. Set as heat pump, furnace control or air handler control. <p>NOTE: This is applicable in non-communicating applications only.</p>	Automatically clears after the missing or incorrectly installed jumper is installed or corrected.
132		Service Urgent	Device Control Software Fault	<p>System component control software is corrupted.</p> <ul style="list-style-type: none"> Recycle power. If failure re-occurs, replace the system component control. 	Manual system power reset is required to recover from this alert code.
150		Service Urgent	A leak of refrigerant has been detected by the refrigerant detection system.	<p>This may indicate the presence of a leak at or in the indoor unit coil of the equipment, that will need to be repaired for proper and safe system operation. Additionally it may indicate that proper refrigerant charge will need to be verified. This fault cannot be cleared while the refrigerant detection system sensor is reporting the presence of a leak.</p>	Locate and repair refrigerant leak, automatically clears when RDS sensor does not detect the presence of refrigerant.
151		Service Soon / Service Urgent	Refrigerant Leak Detector Sensor #1 Fault	<ul style="list-style-type: none"> The refrigerant detection sensor in the indoor unit is reporting an issue that prevents it from functioning properly, and replacement of the sensor may be necessary. This fault clears when the sensor no longer reports the presence of a fault condition. If it's a field installed RDS control or a gas furnace with an integral RDS control, check Sensor 1 Dip switch configuration. 	Automatically clears when an RDS sensor is detected and Dip switches are set to enable Sensor 1
152		Service Soon / Service Urgent	Refrigerant Leak Detector Sensor #1 Fault	<ul style="list-style-type: none"> The refrigerant detection sensor in the indoor unit is reporting an issue that prevents it from functioning properly, and replacement of the sensor may be necessary. This fault clears when the sensor no longer reports the presence of a fault condition. If it's a field installed RDS control or a gas furnace with an integral RDS control, check Sensor 1 Dip switch configuration. 	Automatically clears when an RDS sensor is detected and Dip switches are set to enable Sensor 1

Table 22. Lennox® S40 Smart Thermostat Alert Codes and Troubleshooting

E2A=Errors to Action, GF= Gas Furnace, AH=Air Handler, IU=Indoor unit (GF or AH), HP=Heat Pump, AC=Air Conditioner, OU=Outdoor Unit (AC or HP), PA=Pure Air S, ZA=Zone system, SRS=Smart Room Sensor, TS=Thermostat , IAQ- IAQ Monitor and WE=Wi-Fi Extender

Alert Code	Inverter Flash Code	Priority Condition	Actual Displayed Alert Text Under dealer control center > Notifications	Component or System Operational State and Troubleshooting Tip	How to clear alert code
154		Service Soon / Service Urgent	RDS sensor #1 has lost communication	Refrigerant leak sensor #1 has lost communication with the system. <ul style="list-style-type: none"> • Check the connection of the refrigerant leak sensor and ensure it is not loose and has no dust/condensation accumulation. • If connection is good and issue persists, then replace the sensor. 	<ul style="list-style-type: none"> • Check the wiring and the connector for damage or improper connectivity. • Check the sensor for damage or signs that it must be replaced. This fault clears when communications with the sensor has been reestablished, but latches for a minimum of five (5) minutes. Retesting the fault can be affected by pressing the RDS test button on the indoor unit control board. • Automatically when the RDS sensor is plugged in and connection is established or RDS sensor is replaced.
155		Service Soon / Service Urgent	RDS sensor #2 has lost communication	<ul style="list-style-type: none"> • Check the connection of the refrigerant leak sensor and ensure it is not loose and has no dust/condensation accumulation. • If connection is good and issue persists, then replace the sensor. 	<ul style="list-style-type: none"> • Check the wiring and the connector for damage or improper connectivity. • Check the sensor for damage or signs that it must be replaced. This fault clears when communications with the sensor has been reestablished, but latches for a minimum of five (5) minutes. Retesting the fault can be affected by pressing the RDS test button on the indoor unit control board. • Automatically when the RDS sensor is plugged in and connection is established or RDS sensor is replaced.

Table 22. Lennox® S40 Smart Thermostat Alert Codes and Troubleshooting

E2A=Errors to Action, GF= Gas Furnace, AH=Air Handler, IU=Indoor unit (GF or AH), HP=Heat Pump, AC=Air Conditioner, OU=Outdoor Unit (AC or HP), PA=Pure Air S, ZA=Zone system, SRS=Smart Room Sensor, TS=Thermostat , IAQ- IAQ Monitor and WE=Wi-Fi Extender

Alert Code	Inverter Flash Code	Priority Condition	Actual Displayed Alert Text Under dealer control center > Notifications	Component or System Operational State and Troubleshooting Tip	How to clear alert code
160		Service Urgent	Refrigerant Leak Detector Sensor 1 Type Incorrect	In applications with two Refrigerant Detection System Sensors, the two refrigerant sensors are not the same refrigerant sensor type.	<p>May occur when two sensors are installed and the two sensors are not the same refrigerant type.</p> <ul style="list-style-type: none"> • If one of sensors is a R454B refrigerant sensor and the other sensor a R32/R454B refrigerant sensor this alarm will occur. • When two sensors are used, sensor 1 & 2 must both be R454B refrigerant sensors or sensor 1 & 2 must both be R32/R454B refrigerant sensors. • Replace one of the sensors with a new sensor so the two sensors are the same refrigerant type. • Heating and cooling will be allowed and the blower will operate continuously during this alarm. The alarm will automatically clear once both RDS sensors are the same refrigerant type.tton on the indoor unit control board.

Table 22. Lennox® S40 Smart Thermostat Alert Codes and Troubleshooting

E2A=Errors to Action, GF= Gas Furnace, AH=Air Handler, IU=Indoor unit (GF or AH), HP=Heat Pump, AC=Air Conditioner, OU=Outdoor Unit (AC or HP), PA=Pure Air S, ZA=Zone system, SRS=Smart Room Sensor, TS=Thermostat , IAQ- IAQ Monitor and WE=Wi-Fi Extender

Alert Code	Inverter Flash Code	Priority Condition	Actual Displayed Alert Text Under dealer control center > Notifications	Component or System Operational State and Troubleshooting Tip	How to clear alert code
161		Service Urgent	Refrigerant Leak Detector Sensor 2 Type Incorrect	In applications with two Refrigerant Detection System Sensors, the two refrigerant sensors are not the same refrigerant sensor type.	<p>May occur when two sensors are installed and the two sensors are not the same refrigerant type.</p> <ul style="list-style-type: none"> • If one of sensors is a R454B refrigerant sensor and the other sensor a R32/R454B refrigerant sensor this alarm will occur. • When two sensors are used, sensor 1 & 2 must both be R454B refrigerant sensors or sensor 1 & 2 must both be R32/R454B refrigerant sensors. • Replace one of the sensors with a new sensor so the two sensors are the same refrigerant type. • Heating and cooling will be allowed and the blower will operate continuously during this alarm. The alarm will automatically clear once both RDS sensors are the same refrigerant type.tton on the indoor unit control board.
163		Critical	The refrigerant detection system controller has failed.	<ul style="list-style-type: none"> • There appears to be an issue with the refrigerant detection system controller on the indoor unit control board, preventing the refrigerant detection system from operating properly. • Thermostat has detected a low GWP communicating outdoor unit and the system is missing an RDS (Refrigerant Detection System) 	This may require the replacement of the indoor unit control board. This fault clears when the refrigerant detection system controller operates normally.
180		Service Soon	Outdoor Temperature Sensor Problem	<p>The thermostat has found a problem with the outdoor temperature sensor. In normal operation after system component control recognizes sensors, the alert code will be sent if valid temperature reading is lost.</p> <ul style="list-style-type: none"> • Compare outdoor sensor resistance to temperature / resistance charts in unit installation instructions. Replace sensors pack if necessary. • At the beginning of (any) configuration, furnace, air handler control or equipment interface module will detect the presence of the sensor(s). • If detected (reading in range), appropriate feature will be set as 'installed' and shown in the 'About' screen. 	Automatically clears upon configuration, or sensing normal values.
181		Service Soon	OU Suction Pressure Transducer Fault	<ul style="list-style-type: none"> • Suction Pressure Transducer reading above 4.75V or below 0.25V for 24hrs +/- 3hrs. Run on staged operation. 	Resets after 3 consecutive readings that are in range
182		Service Soon	OU Suction Temperature Sensor Fault	<ul style="list-style-type: none"> • Reading below 0.25V or above 4.75V for 24hrs +/- 3hrs. System will continue to operate normally. 	Resets after 3 consecutive readings that are in range

Table 22. Lennox® S40 Smart Thermostat Alert Codes and Troubleshooting

E2A=Errors to Action, GF= Gas Furnace, AH=Air Handler, IU=Indoor unit (GF or AH), HP=Heat Pump, AC=Air Conditioner, OU=Outdoor Unit (AC or HP), PA=Pure Air S, ZA=Zone system, SRS=Smart Room Sensor, TS=Thermostat , IAQ- IAQ Monitor and WE=Wi-Fi Extender					
Alert Code	Inverter Flash Code	Priority Condition	Actual Displayed Alert Text Under dealer control center > Notifications	Component or System Operational State and Troubleshooting Tip	How to clear alert code
183		Service Soon	OU Liquid Pressure Sensor Fault	<ul style="list-style-type: none"> Under 0.25V and above 4.75V readings for 24 hours +/-3hrs or more on the sensor will cause this error. Continue normal operation, see sections related to low pressure switch emulation for specific details related to low pressure switch faults. 	Resets after 3 consecutive readings that are in range
184		Service Soon	OU Liquid Temperature Sensor Fault	<ul style="list-style-type: none"> Sensor shorted or open for 24 hours +/-3hrs or more. Continue normal operation. 	Resets after 3 consecutive readings that are in range
186		Service Soon	Discharge Temp Sensor Check	<p>Discharge line temperature is less than Top Cap Temperature minus 20°F (-6.7°C) following a top cap thermostat trip.</p> <ul style="list-style-type: none"> Check discharge line temperature sensor location and verify the sensor is secure on the discharge line. Nominal resistance of the sensor is 10K ohms at 77°F (25°C). See unit service manual for sensor resistance. 	Automatically clears after top cap thermostat resets.
187		Service Soon	Discharge Temperature/Pressure too high	Discharge temperature or pressure ratio exceeded upper limit. Heat pump heating stopped.	Automatically clears after discharge temperature or pressure ratio drops below the lower limit following a demand stop.
200		Service Urgent	GF Rollout Limit Switch Open	<p>The furnace roll out limit switch is open. Correct the cause of roll out trip.</p> <ul style="list-style-type: none"> Reset roll out switch. Test the furnace operation. Check for blocked or obstructed vent pipe (Intake and/or Exhaust). Check for flame stability, if flame is unstable, look for cause. 	Automatically clears after the furnace roll out switch is closed.
201		Service Soon / Service Urgent	IU Blower Motor Fault	<p>Lost communication with indoor blower motor.</p> <ul style="list-style-type: none"> Possible causes include power outage, brown-out, motor not powered, loose wiring, condensation on system component control without cover on breaker. Problem may be on system component control or motor side. 	Automatically clears after communication is restored.
202		Service Urgent	IU Blower Motor & Unit Size Mismatch	<p>The unit size code for the indoor unit and the size of blower motor do not match. Incorrect appliance unit size code selected.</p> <ul style="list-style-type: none"> Remove the thermostat from the system while applying power and reprogramming. Check for proper configuring under unit size codes for furnace/air handler in configuration guide or in installation instructions. 	Automatically clears after the correct match is detected following a reset.
203		Service Urgent	IU Invalid Size Unit Code	<p>The unit size code for the indoor unit has not been selected or set incorrectly.</p> <ul style="list-style-type: none"> Verify that the correct unit size code is configured. Unit size codes for furnace and air handler are listed in the system component configuration guide or installation instruction. Remove the thermostat from the system while applying power and set the unit size code per instructions provided in the indoor unit installation instruction. 	Automatically clears after the correct match is detected following a reset.

Table 22. Lennox® S40 Smart Thermostat Alert Codes and Troubleshooting

E2A=Errors to Action, GF= Gas Furnace, AH=Air Handler, IU=Indoor unit (GF or AH), HP=Heat Pump, AC=Air Conditioner, OU=Outdoor Unit (AC or HP), PA=Pure Air S, ZA=Zone system, SRS=Smart Room Sensor, TS=Thermostat , IAQ- IAQ Monitor and WE=Wi-Fi Extender

Alert Code	Inverter Flash Code	Priority Condition	Actual Displayed Alert Text Under dealer control center > Notifications	Component or System Operational State and Troubleshooting Tip	How to clear alert code
204		Service Urgent	GF Check Gas Valve	There is an issue with the furnace gas valve. <ul style="list-style-type: none"> • Check gas valve operation and wiring. • Check for voltage to the gas valve. 	Automatically clears after the issue is corrected.
205		Service Urgent	GF Gas Valve Relay Contact Closed	The furnace gas valve relay contact is closed. <ul style="list-style-type: none"> • Check wiring on control and gas valve. The relay is located on the furnace control . • If issue continues replace furnace control. 	Automatically clears after the issue is corrected.
206		Service Soon	GF Gas Valve 2nd Stage Relay Fault	The furnace gas valve second-stage relay is faulty. <ul style="list-style-type: none"> • Furnace will operate on first-stage for the remainder of the heating demand. • If unable to operate second-stage, replace furnace control. 	Automatically clears after the issue is corrected.
207		Service Urgent	GF HSI Sensed Open	The furnace hot surface igniter is open. <ul style="list-style-type: none"> • Measure the resistance of hot surface igniter. • Replace the igniter if it is not within the specified range found in furnace installation instruction. 	Automatically clears after the issue is corrected.
223		Service Soon	GF Low Pressure Switch Open	The furnace low pressure switch is open. <ul style="list-style-type: none"> • Check pressure (inches w.c.) of the low pressure switch closing during a heat call. • Measure operating pressure (inches w.c.). • Inspect vent for blockages and combustion air inducer for correct operation and restriction. • Check for blocked cold end heater box or condensate drain or drain strainers at outlet of cold end heater box. • Check for cracked hoses. • Check levelness of unit. <p>NOTE: Check Service Manual and Service and Application Note H-13-07 "Condensing Furnace Pressure Switch Troubleshooting" for additional information.</p>	Automatically clears after the issue is corrected.

Table 22. Lennox® S40 Smart Thermostat Alert Codes and Troubleshooting

E2A=Errors to Action, GF= Gas Furnace, AH=Air Handler, IU=Indoor unit (GF or AH), HP=Heat Pump, AC=Air Conditioner, OU=Outdoor Unit (AC or HP), PA=Pure Air S, ZA=Zone system, SRS=Smart Room Sensor, TS=Thermostat , IAQ- IAQ Monitor and WE=Wi-Fi Extender

Alert Code	Inverter Flash Code	Priority Condition	Actual Displayed Alert Text Under dealer control center > Notifications	Component or System Operational State and Troubleshooting Tip	How to clear alert code
224		Service Urgent	GF Low Pressure Switch Stuck Closed	<p>The furnace low pressure switch is stuck closed.</p> <ul style="list-style-type: none"> • Check operation of low pressure switch to see if it is stuck closed for longer than 150 seconds during a heat call. • Measure operating pressure (inches w.c.). • Inspect vent for blockage and combustion air inducer for correct operation and restriction. • Check for moisture in pressure switch. <p>NOTE: Check Service Manual and Service and Application Note H-13-07 “Condensing Furnace Pressure Switch Troubleshooting” for additional information.</p> <p>Other possible issues that are specific to the older Lennox communicating thermostats are as follows: It has been determined that this alert code is generated when a subsequent heating call occurs within 30 seconds of a prior call for heat ending. If a call for heat occurs during this time period, the inducer post-purge from the previous call may still be in process. If that condition exists, the IFC will sense the pressure switch circuit is closed therefore activating the alert code 224 and generate an email notification. Once the fault is cleared, typically seconds after being generated, the subsequent call for heat will be initiated and the furnace will return to normal operation.</p> <p>Lennox has not received any complaints of no heat situations associated with this operating condition. It has been determined that occasionally the fault clears itself and the alert code is not stored in the IFC or Lennox communicating thermostat.</p>	Automatically clears after the issue is corrected.
225		Service Soon	GF High Pressure Switch Failed to Close	<p>The furnace high pressure switch will not close.</p> <ul style="list-style-type: none"> • Check pressure (inches w.c.) of high pressure switch closing during a heat call. • Measure operating pressure (inches w.c.). • Inspect vent for blockage and combustion air inducer for correct operation and restriction. • Check for blocked cold end heater box or condensate drain or drain strainers at outlet of the cold end heater box. • Check cracked hoses • Check levelness of unit. <p>NOTE: Check Service Manual and Service and Application Note H-13-07 “Condensing Furnace Pressure Switch Troubleshooting” for additional information.</p>	
226		Service Urgent	GF High Pressure Switch Stuck Closed	<p>The furnace high pressure switch will not open.</p> <ul style="list-style-type: none"> • Check operation of high pressure switch closing during a heat call. • Measure operating pressure (inches w.c.). • Inspect vent for blockage and combustion air inducer for correct operation and restriction. • Check for moisture in pressure switch. <p>NOTE: Check Service Manual and Service and Application Note H-13-07 “Condensing Furnace Pressure Switch Troubleshooting” for additional information.</p>	Automatically clears after the issue is corrected.

Table 22. Lennox® S40 Smart Thermostat Alert Codes and Troubleshooting

E2A=Errors to Action, GF= Gas Furnace, AH=Air Handler, IU=Indoor unit (GF or AH), HP=Heat Pump, AC=Air Conditioner, OU=Outdoor Unit (AC or HP), PA=Pure Air S, ZA=Zone system, SRS=Smart Room Sensor, TS=Thermostat , IAQ- IAQ Monitor and WE=Wi-Fi Extender

Alert Code	Inverter Flash Code	Priority Condition	Actual Displayed Alert Text Under dealer control center > Notifications	Component or System Operational State and Troubleshooting Tip	How to clear alert code
227		Service Soon	GF Low Pressure Switch Open in Run Mode	<p>The furnace low pressure switch is open while in run mode.</p> <ul style="list-style-type: none"> • Check pressure (inches w.c.) of low pressure switch closing during a heat call. • Measure operating pressure (inches w.c.). • Inspect vent for blockage and combustion air inducer for correct operation and restriction. • Check for blocked cold end heater box or condensate drain or drain strainers at outlet of cold end heater box. • Check for cracked hoses. • Check levelness of unit. <p>NOTE: Check Service Manual and Service and Application Note H-13-07 "Condensing Furnace Pressure Switch Troubleshooting" for additional information.</p>	Automatically clears after the issue is corrected.
228		Service Soon	GF Inducer Calibration Issue	<p>The furnace control is not able to calibrate the pressure switch. Unable to perform pressure switch calibration.</p> <ul style="list-style-type: none"> • Inspect vent for blockage and combustion air inducer for correct operation and restriction. • Check for blocked cold end heater box or condensate drain or drain strainers at outlet of cold end heater box (CEHB). • Check for cracked hoses. • Check levelness of unit. <p>NOTE: Check Service Manual and Service and Application Note H-13-07 "Condensing Furnace Pressure Switch Troubleshooting" for additional information.</p>	Automatically clears after a successful calibration.
229		Information Only-Dealer	GF Ignition on High Fire	<ul style="list-style-type: none"> • Furnace control switched to high fire ignition because low fire pressure switch did not close in allowed time. • *Early models only, if fan is on when call for W1 is initiated; unit will fire on high fire for 60 seconds before dropping down to low fire. 	No action is required.
240		Service Soon	GF Low Flame Current - Run Mode	<p>This could be either low flame current or a loss of flame while in run mode.</p> <ul style="list-style-type: none"> • Check micro-amperes of the flame sensor using thermostat or control board. • Clean or replace the flame sensor. • Measure voltage of neutral to ground to ensure good unit ground. • Clean face of burner assembly. • Confirm that the vent termination is properly installed and not re-circulating. • Check for loose a wiring connection at gas valve. <p>NOTE: Refer to Service and Application Note H-14-06" Flame Rectification In All Gas Furnaces" for additional information.</p>	Automatically clears after a proper micro-amp reading has been sensed.

Table 22. Lennox® S40 Smart Thermostat Alert Codes and Troubleshooting

E2A=Errors to Action, GF= Gas Furnace, AH=Air Handler, IU=Indoor unit (GF or AH), HP=Heat Pump, AC=Air Conditioner, OU=Outdoor Unit (AC or HP), PA=Pure Air S, ZA=Zone system, SRS=Smart Room Sensor, TS=Thermostat , IAQ- IAQ Monitor and WE=Wi-Fi Extender

Alert Code	Inverter Flash Code	Priority Condition	Actual Displayed Alert Text Under dealer control center > Notifications	Component or System Operational State and Troubleshooting Tip	How to clear alert code
241		Service Urgent	GF Flame Out of Sequence-Still Present	<p>Flame sensed without call for gas heating. Perform the following:</p> <ul style="list-style-type: none"> • Shut off gas. • Check for a gas valve leak. • Check for voltage to gas valve. <p>Replace the gas valve if needed.</p>	Automatically clears when a heat call ends successfully.
250		Service Soon	GF Primary Limit Switch Open	<p>The furnace primary limit switch is open. If limit switch is not closed within three minutes, the unit will go into a 60 minute soft lockout (Watchguard mode). Perform the following:</p> <ul style="list-style-type: none"> • Check for high gas pressure. • Check for low supply air. Low supply air due to being plugged or restriction in system (example: dirty air filter or blockage in duct work). • Check for proper firing rate on furnace. • Check for non-functioning zone dampers. <p>NOTE: Limit trips will place the Lennox Smart Zoning system into non-zone mode.</p> <p>NOTE: See ACC-14-01 for further details.</p>	<p>Automatically clears when a heat call ends successfully.</p> <p>NOTE: If this issue occurred on an Lennox Smart Zoning system, the field will need to manually activate the zoning.</p>
252		Service Soon	IU Discharge Air Temperature High	<p>A discharge air-temperature is high. Perform the following:</p> <ul style="list-style-type: none"> • Check temperature rise, air flow and input rate. • Check for dirty air filter(s). <p>NOTE: See <i>Service and Application Note</i> ACC-14-01 for further details.</p>	Automatically clears when a heat call ends successfully.
270		Service Urgent	GF Flame Failed To Ignite	<p>The furnace is in Watchguard mode. The furnace igniter cannot turn on the flame. This is a five strike condition during a single demand.</p> <ul style="list-style-type: none"> • Check for proper gas flow. • Ensure that igniter is lighting burner. • Check flame sensor current. • Check for dirty filters. • Check for blocked cold end heater box or condensate drain and cracked hoses. 	Automatically clears on successful ignition.
271		Service Urgent	GF Low Press Switch Open	<p>The furnace is in Watchguard mode. The furnace low pressure switch is open. This is a five strike condition during a single demand.</p> <ul style="list-style-type: none"> • Check pressure (inches w.c.) of low pressure switch closing during a heat call. • Measure operating pressure (inches w.c.). • Check for blocked cold end heater box (CEHB), or condensate drain or drain strainers at outlet of CEHB and cracked hoses. • Check for cracked hoses. • Check levelness of unit. <p>NOTE: Check <i>Service Manual and Service and Application Note</i> H-13-07 "Condensing Furnace Pressure Switch Troubleshooting" for additional information.</p>	Automatically clears on successful ignition.

Table 22. Lennox® S40 Smart Thermostat Alert Codes and Troubleshooting

E2A=Errors to Action, GF= Gas Furnace, AH=Air Handler, IU=Indoor unit (GF or AH), HP=Heat Pump, AC=Air Conditioner, OU=Outdoor Unit (AC or HP), PA=Pure Air S, ZA=Zone system, SRS=Smart Room Sensor, TS=Thermostat , IAQ- IAQ Monitor and WE=Wi-Fi Extender

Alert Code	Inverter Flash Code	Priority Condition	Actual Displayed Alert Text Under dealer control center > Notifications	Component or System Operational State and Troubleshooting Tip	How to clear alert code
272		Service Urgent	GF Low Press Switch Open Run Mode	<p>The furnace low pressure switch is open during run mode. The system will go into Watchguard mode.</p> <ul style="list-style-type: none"> • Check operation of low pressure switch to see if it is stuck open during a heat call. • Measure operating pressure (inches w.c.). • Inspect vent for blockages, and combustion air inducer for correct operation and restriction. • Check for blocked cold end heater box (CEHB), or condensate drain or drain strainers at outlet of CEHB and cracked hoses. • Check for cracked hoses. • Check levelness of unit. <p>NOTE: Check Service Manual and Service and Application Note H-13-07 "Condensing Furnace Pressure Switch Troubleshooting" for additional information.</p>	Automatically clears when a heat call ends successfully.
273		Service Urgent	GF Flame Fail In Run Mode	<p>The furnace flame is going off during a heating cycle. The system will go into Watchguard mode.</p> <ul style="list-style-type: none"> • Check micro-amperes of flame sensor using thermostat or control diagnostics. • Clean or replace sensor. • Measure voltage of neutral to ground to ensure good unit ground. • Clean face of burner assembly. 	Automatically clears when a heat call ends successfully.
274		Service Urgent	GF Primary Limit Switch Open	<p>The furnace limit switch has been open for more than three minutes. The system will go into Watchguard mode. In Lennox Smart Zoning systems, the limit trips will place the system into central mode.</p> <ul style="list-style-type: none"> • Check for high gas pressure. • Low supply air due to being plugged or restriction in system (example: dirty air filter or blockage in duct work). • Check for proper firing rate on furnace. • Check for non-functioning zone dampers. <p>NOTE: Refer to Service and Application Note ACC-14-01 - iHarmony® (Smart Zoning) and SLP98 - Insufficient Zone Heating and Alert Code 250 Issues for corrective actions.</p>	Automatically clears when a heat call ends successfully.
275		Service Urgent	GF Flame Out Of Seq. No Flame	<p>The furnace flame is out of sequence. The system will go into Watchguard mode.</p> <ul style="list-style-type: none"> • Shut off gas. • Check for gas valve leak. 	Automatically clears on successful ignition.

Table 22. Lennox® S40 Smart Thermostat Alert Codes and Troubleshooting

E2A=Errors to Action, GF= Gas Furnace, AH=Air Handler, IU=Indoor unit (GF or AH), HP=Heat Pump, AC=Air Conditioner, OU=Outdoor Unit (AC or HP), PA=Pure Air S, ZA=Zone system, SRS=Smart Room Sensor, TS=Thermostat , IAQ- IAQ Monitor and WE=Wi-Fi Extender

Alert Code	Inverter Flash Code	Priority Condition	Actual Displayed Alert Text Under dealer control center > Notifications	Component or System Operational State and Troubleshooting Tip	How to clear alert code
276		Service Urgent	GF Calibration Failure	<p>The furnace is not able to calibrate or the high pressure switch opened or failed to close in run mode. The system will go into Watchguard mode.</p> <ul style="list-style-type: none"> • Measure operating pressure (inches w.c.). • Inspect vent for blockages, and combustion air inducer for correct operation and restriction. • Check for blocked cold end heater box (CEHB), or condensate drain or drain strainers at outlet of CEHB and cracked hoses. • Check for cracked hoses. • Check levelness of unit. <p>NOTE: Check Service Manual and Service and Application Note H-13-07 "Condensing Furnace Pressure Switch Troubleshooting" for additional information.</p>	Automatically clears when the furnace calibrates itself successfully.
290		Service Urgent	GF Ignition Circuit Fault	<p>There is a problem with the furnace ignition circuit. The system will go into Watchguard mode. Measure resistance of hot surface igniter. Replace the hot surface igniter if it is not within specifications.</p>	Automatically clears on successful ignition
291		Service Urgent	GF Heat Airflow Below Min	<p>The heating airflow is below the minimum required level. The system will go into Watchguard mode.</p> <ul style="list-style-type: none"> • Check for dirty air filter(s) and other air flow restrictions. • Check blower performance. 	Automatically clears when a heat call ends successfully.
292		Service Urgent	ID Blower Motor Start Fault	<p>The indoor unit blower motor will not start. The system will go into Watchguard mode.</p> <ul style="list-style-type: none"> • Indoor blower motor unable to start. • This could be due to seized bearing, stuck wheel, and obstructions. • Replace motor, motor module, or wheel if assembly does not operate or meet performance standards. <p>NOTE: Refer to Service and Application Note H-17-02 "All Communicating Variable Speed Motors".</p>	Automatically clears after the indoor blower motor starts successfully.
294		Service Soon / Service Urgent	GF Inducer Motor Overcurrent	<p>There is over current in the furnace inducer motor. The system will go into Watchguard mode.</p> <ul style="list-style-type: none"> • Check combustion blower bearings, wiring and amps. • Replace furnace inducer motor if it does not operate or does not meet performance standards. 	Automatically clears after inducer motor current is sensed to be in-range after the ignition following either Watchguard mode or unit reset.
295		Service Soon	ID Blower Over Temperature	<p>The indoor blower motor is overheating. Indoor blower motor over temperature (motor tripped on internal protector).</p> <ul style="list-style-type: none"> • Check motor bearings and amps. • Replace indoor blower motor if necessary. • Check for high duct static. 	Automatically clears after blower demand is satisfied.

Table 22. Lennox® S40 Smart Thermostat Alert Codes and Troubleshooting

E2A=Errors to Action, GF= Gas Furnace, AH=Air Handler, IU=Indoor unit (GF or AH), HP=Heat Pump, AC=Air Conditioner, OU=Outdoor Unit (AC or HP), PA=Pure Air S, ZA=Zone system, SRS=Smart Room Sensor, TS=Thermostat , IAQ- IAQ Monitor and WE=Wi-Fi Extender

Alert Code	Inverter Flash Code	Priority Condition	Actual Displayed Alert Text Under dealer control center > Notifications	Component or System Operational State and Troubleshooting Tip	How to clear alert code
310		Service Soon	Discharge Air Temp Sensor Error	<p>There is a discharge air temperature sensor issue.</p> <ul style="list-style-type: none"> • Confirm there is no short or open circuits in the Lennox communicating thermostat connections to any of the other components in the communicating system. • Compare discharge air temperature sensor (DATS) resistance to temperature / resistance charts in system component installation instruction. • Replace discharge air sensor if necessary. <p>NOTE: Issues with a DATS connected to a damper control module or equipment interface model will not generate an alert code.</p>	Automatically clears 30 seconds after condition is detected as recovered or after system restart.
311		Information Only-Dealer	GF Heat Rate Reduced To Match Airflow	<p>The heat firing rate has been reduced to match available airflow (cutback mode). This is a alert code. Furnace blower in cutback mode due to restricted airflow.</p> <ul style="list-style-type: none"> • Reduce firing rate every 60 seconds to match available CFM. • Check air filter and duct system. • To clear, replace air filter if needed or repair or add additional ducting. <p>Two-stage controls will reduce firing rate to first stage.</p>	Automatically clears when a heating call finishes successfully.
312		Information Only-Dealer	Reduced/Airflow-Indoor Blower Cutback	<p>The indoor blower cannot provide the requested CFM due to excessive static pressure. This is a minor alert code.</p> <ul style="list-style-type: none"> • Static pressure has exceeded the capability of the blower motor. • Possible restricted airflow - Indoor blower is running at a reduced CFM (cutback mode). • The variable speed motor has pre-set speed and torque limiters to protect the motor from damage caused by operating outside of design parameters (0 to 0.8" e.g. total external static pressure). • Check air filter and duct system. • To clear, replace air filter if needed or repair or add additional ducting. <p>NOTE: Blower motor cutbacks will not show alarm code. Duct static pressure reading must be taken.</p>	Automatically clears when a heating call finishes successfully.
344		Service Urgent	GF IFC Relay Y1 Stuck	<p>Link Relay Problem. Issue could be with possible Y1 relay failure.</p> <p>NOTE: Relay is located on the IFC (Integrated Furnace Control). If issue continues replace IFC.</p>	Automatically clears five minutes after Y1 input sensed OFF.
345		Service Urgent	Relay O Failure	<p>The O relay on the system component has failed. Either the pilot relay contacts did not close or the relay coil did not energize.</p> <ul style="list-style-type: none"> • Possible O relay / stage 1 failure. • Pilot relay contacts did not close or the relay coil did not energize. • Replace system component (device) control. <p>If error is applicable to the Lennox variable capacity outdoor units, the outdoor control will need to be replaced.</p>	Automatically clears after the fault recovered following reset.

Table 22. Lennox® S40 Smart Thermostat Alert Codes and Troubleshooting

E2A=Errors to Action, GF= Gas Furnace, AH=Air Handler, IU=Indoor unit (GF or AH), HP=Heat Pump, AC=Air Conditioner, OU=Outdoor Unit (AC or HP), PA=Pure Air S, ZA=Zone system, SRS=Smart Room Sensor, TS=Thermostat , IAQ- IAQ Monitor and WE=Wi-Fi Extender

Alert Code	Inverter Flash Code	Priority Condition	Actual Displayed Alert Text Under dealer control center > Notifications	Component or System Operational State and Troubleshooting Tip	How to clear alert code
346		Service Urgent	AH HP Jumper Not Removed	<p>The heat pump configuration link is not cut on the air handler control.</p> <ul style="list-style-type: none"> • Configuration link not cut on air handler control. • Cut O to R. <p>NOTE: <i>This is only applicable when matching non-communicating heat pump with Lennox communicating indoor unit.</i></p>	Automatically clears when the system detects that the issue no longer exists.
347		Service Urgent	IU or EIM Relay Y1 Fault	<ul style="list-style-type: none"> • Lennox communicating thermostat sends a Y1 compressor demand to the indoor control requesting it to relay the demand to the outdoor unit. • The indoor unit communicating control will verify the presences of 24VAC between the Y1 and C on its terminals. If it does not detects the presences 24VAC, it will trigger alert code 347. <p>Possible cause for alert code 347 is Y1 relay on the applicable system component has failed. Either the furnace pilot relay contacts did not close or the relay coil did not energize.</p> <ul style="list-style-type: none"> • System operation will stop. • Possible Y1 relay / stage 1 failure. • Furnace pilot relay contacts did not close or the relay coil did not energize. <p>NOTE: <i>There is no input back to the applicable system component control.</i></p>	Automatically clears after reset and Y1 input sensed.
348		Service Soon	ID Relay Y2 Fault	<p>Possible cause for alert code 348 is Y2 relay on the applicable system component may have failed.</p> <p>Lennox communicating thermostat sends a Y2 compressor demand to the indoor control requesting it to relay the demand to the outdoor unit.</p> <p>The indoor unit communicating control will verify the presences of 24VAC between the Y1 and C on its terminals. If it does not detects the presences 24VAC, it will trigger alert code 348. Either the furnace pilot relay contacts did not close or the relay coil did not energize.</p> <ul style="list-style-type: none"> • Possible Y2 relay / stage 2 failure. • Furnace pilot relay contacts did not close or the relay coil did not energize. • No input back to furnace or air handler control. 	Automatically clears when the system detects that the issue no longer exists.
349		Service Urgent	GF IFC Error Check Jumper O to R	<ul style="list-style-type: none"> • Only applicable in non-communicating mode. • The O to R link on the furnace has been cut and could possibly cause a brown out. • Might also result in low voltage to which would generate alert code as well. • Configuration link R to O needs to be restored. Will need to restore link by hard-wiring the R to O terminals on the terminal strip. 	Automatically clears when the system detects that the issue no longer exists.
350		Service Urgent	AH Electric Heat Not Configured	<p>The air handler's electric heat is not configured or incorrectly configured.</p> <ul style="list-style-type: none"> • Heat call with no configured or incorrectly configured electric heat. • Check for proper configuring under Configuring Electric Heat Stages in the air handler installation instructions. <p>NOTE: <i>Thermostat MUST be removed from the system before configuring electric heat.</i></p>	Automatically clears after electrical heat detection is successful.

Table 22. Lennox® S40 Smart Thermostat Alert Codes and Troubleshooting

E2A=Errors to Action, GF= Gas Furnace, AH=Air Handler, IU=Indoor unit (GF or AH), HP=Heat Pump, AC=Air Conditioner, OU=Outdoor Unit (AC or HP), PA=Pure Air S, ZA=Zone system, SRS=Smart Room Sensor, TS=Thermostat , IAQ- IAQ Monitor and WE=Wi-Fi Extender

Alert Code	Inverter Flash Code	Priority Condition	Actual Displayed Alert Text Under dealer control center > Notifications	Component or System Operational State and Troubleshooting Tip	How to clear alert code
351		Service Urgent	AH Electric Heat Stage 1 Fault	There is an issue with the air handler's first stage electric heat. Either the pilot relay contacts did not close or the relay coil in the electric heat section did not energize. Possible heat section / stage 1 failure. NOTE: <i>Air handler will operate on heat pump first stage for the remainder of the heat call.</i>	Automatically clears after fault recovered.
352		Service Soon	AH Electric Heat Stage 2 Fault	There is a issue with the air handler's second stage electric heat. Either the pilot relay contacts did not close or the relay coil in the electric heat section did not energize. NOTE: <i>The air-handler will operate on first stage electric heat until the issue is resolved.</i>	Automatically clears after fault recovered.
353		Service Soon	AH Electric Heat Stage 3 Fault	There is a issue with the air handler's third stage electric heat. Either the pilot relay contacts did not close or the relay coil in the electric heat section did not energize. NOTE: <i>The air-handler will operate on first stage electric heat until the issue is resolved.</i>	Automatically clears after fault recovered.
354		Service Soon	Electric Heat AH Electric Heat Stage 4 Fault	There is a issue with the air handler's fourth stage electric heat. Either the pilot relay contacts did not close or the relay coil in the electric heat section did not energize. NOTE: <i>The air-handler will operate on first stage electric heat until the issue is resolved.</i>	Automatically clears after fault recovered.
355		Service Soon	AH Electric Heat Stage 5 Fault	There is an issue with the air handler's fifth stage electric heat. Either the pilot relay contacts did not close or the relay coil in the electric heat section did not energize. NOTE: <i>The air-handler will operate on first stage electric heat until the issue is resolved.</i>	Automatically clears after fault recovered.

Table 22. Lennox® S40 Smart Thermostat Alert Codes and Troubleshooting

E2A=Errors to Action, GF= Gas Furnace, AH=Air Handler, IU=Indoor unit (GF or AH), HP=Heat Pump, AC=Air Conditioner, OU=Outdoor Unit (AC or HP), PA=Pure Air S, ZA=Zone system, SRS=Smart Room Sensor, TS=Thermostat , IAQ- IAQ Monitor and WE=Wi-Fi Extender

Alert Code	Inverter Flash Code	Priority Condition	Actual Displayed Alert Text Under dealer control center > Notifications	Component or System Operational State and Troubleshooting Tip	How to clear alert code
370		Service Urgent	GF Interlock Switch Open	<p>Communicating Mode:</p> <p>NOTE: The on-board jumper DS-R (W914) will be cut.</p> <p>In communicating mode, the DS-R terminal is used with the EL296 and SL280 furnaces and will be used to monitor a field-installed interlock switch such as for example a float switch. When operating in this capacity, the DS jumper will be monitored as follows:</p> <ul style="list-style-type: none"> • When no alert codes are present there will be 24VAC present at this terminal. • When control see the loss of 24VAC for two minutes it will send an alert code 370 and disable heating function. • If currently running a demand it will de-energize all outputs (including the blower). • In case of an existing interlock switch alert code, upon power reset, an alert code message will be sent if voltage is not sensed on the DS terminal. • An alert code clearing message will be sent if 24VAC is sensed on DS terminal for the minimum of 10 seconds. • The monitoring of DS terminal will apply to both variable speed and constant torque controls. <p>Non-Communicating Mode:</p> <p>NOTE: The on-board jumper DS-R (W914) will NOT be cut.</p> <p>The furnace control has not received 24VAC power for two minutes or more on the DS terminal</p> <ul style="list-style-type: none"> • The system will not operate. • Dealer has cut the W914 jumper (Dehum, Harmony III) on the Lennox furnace control. • The thermostat monitors the DS terminal in the furnace for power and if the link has been cut then power will be lost to DS. • If DS to R terminal is accidentally cut you must reconnect a jumper from the DS to R on the terminals strip. 	This alert code will clear when 24VAC is continuously sensed on DS terminal for a minimum of 10 seconds or on a power reset.
371		Service Soon / Service Urgent	AH Float Switch Sensed Open	After being active for 10 minutes (600 seconds) the priority condition will change to Service Urgent.	Automatically clears after fault recovered.
380		Service Soon / Service Urgent	EIM Interlock Relay Fault	Interlock relay failure (furnace or air handler modes only). <ul style="list-style-type: none"> • Interlock relay is energized, but input is not sensed after three seconds. • There will be no heating or cooling due to this alert code – service soon condition. • De-energize interlock relay and energize after five minutes if demand is still present – service urgent condition. 	Automatically clears after fault recovered.
381		Service Soon / Service Urgent	EIM Interlock Relay Stuck	Interlock relay stuck (furnace or air handler modes only). <ul style="list-style-type: none"> • Interlock relay continuously sensed (with relay off). • There is no heating and cooling operation – service urgent condition. • After 10 minutes if event still exist it will be escalated to priority condition service urgent. 	Automatically clears 30 seconds after fault clears.

Table 22. Lennox® S40 Smart Thermostat Alert Codes and Troubleshooting

E2A=Errors to Action, GF= Gas Furnace, AH=Air Handler, IU=Indoor unit (GF or AH), HP=Heat Pump, AC=Air Conditioner, OU=Outdoor Unit (AC or HP), PA=Pure Air S, ZA=Zone system, SRS=Smart Room Sensor, TS=Thermostat , IAQ- IAQ Monitor and WE=Wi-Fi Extender

Alert Code	Inverter Flash Code	Priority Condition	Actual Displayed Alert Text Under dealer control center > Notifications	Component or System Operational State and Troubleshooting Tip	How to clear alert code
382		Service Urgent	EIM Relay W1 Fault	Relay W1 failure (furnace or air handler modes only). W1 relay is energized but input is not sensed after three seconds.	Automatically clears when W1 relay input is sensed.
400		Service Soon	OU LSOM Comp. Internal Overload Tripped	The compressor internal overload has tripped. <ul style="list-style-type: none"> Thermostat demand Y1 is present; however compressor is not running. Check power to unit. 	This alert code is automatically cleared after current is sensed in both RUN and START sensors for at least two seconds or after service is removed, or after power reset.
401		Information Only-Dealer	OU Compressor Long Run Cycle	Either the compressor ran for more than 18 hours continuously while attempting to cool the home during a single demand or the system refrigerant pressure is low. <ul style="list-style-type: none"> Alert code will not lockout system. If the two-stage outdoor unit has an outdoor control with flashing LED lights then the unit will run in low speed; An outdoor control with a seven-segment display, the outdoor control will display alert code 401, but continue to run in high speed. If the outdoor unit is a heat pump, and the outdoor temperature is less than 65°F, alert code 401 is ignored. Also monitors low pressure switch trips. 	Automatically clears after 30 consecutive normal run cycles or power reset.
402		Service Soon	OU System Pressure Trip	<ul style="list-style-type: none"> Either the discharge or suction pressure level is out-of-limits, or the compressor has overloaded. Check discharge or suction pressure. 	Automatically clears after four consecutive normal compressor run cycles.
403		Service Soon	OU Compressor Short-Cycling	The compressor ran for less than three minutes to satisfy a thermostat demand.	Automatically clears after four consecutive normal compressor run cycles.
404		Service Urgent	OU Compressor Rotor Locked	The compressor rotor is locked up due to either: <ul style="list-style-type: none"> Run capacitor short. Bearings are seized. Excessive liquid refrigerant. <p>NOTE: May need to install hard start kit.</p>	Automatically clears after four consecutive normal run cycles or after power reset.
405		Service Urgent	OU Compressor Open Circuit	The compressor circuit is open due to: <ul style="list-style-type: none"> Power disconnection - Open fuse 	Automatically clears after one normal compressor run cycle.
406		Service Urgent	OU Compressor Open Start Circuit	The required amount of current is not passing through the START current transformer.	Automatically clears after current is sensed in START sensor, or after power reset.

Table 22. Lennox® S40 Smart Thermostat Alert Codes and Troubleshooting

E2A=Errors to Action, GF= Gas Furnace, AH=Air Handler, IU=Indoor unit (GF or AH), HP=Heat Pump, AC=Air Conditioner, OU=Outdoor Unit (AC or HP), PA=Pure Air S, ZA=Zone system, SRS=Smart Room Sensor, TS=Thermostat , IAQ- IAQ Monitor and WE=Wi-Fi Extender

Alert Code	Inverter Flash Code	Priority Condition	Actual Displayed Alert Text Under dealer control center > Notifications	Component or System Operational State and Troubleshooting Tip	How to clear alert code
407		Service Urgent	OU Compressor Open Run Circuit	The required amount of current is not passing through RUN current transformer.	Automatically clears after current is sensed in RUN sensor, one normal compressor run cycle, or after power reset
408		Service Urgent	OU Compressor Contactor Welded	The compressor is running continuously.	Automatically clears one normal compressor run cycle or after power reset.
409		Service Soon	OU Control Board Low 24VAC	The secondary voltage for the applicable system component has fallen below 18VAC. This may be due to: <ul style="list-style-type: none"> • Secondary voltage is below 18VAC. • If this continues for 10 minutes, the thermostat will turn off the applicable system component. 	Automatically clears after voltage is detected as higher than 20VAC for two seconds or after power reset.
410		Information Only-Dealer	OU Open Low Pressure Switch	Unit low pressure is below the required limit. <ul style="list-style-type: none"> • Check operating pressures. • Low pressure switch opens at a specific pressure (system shuts down) and closes at a specific pressure (system restarts). 	Automatically clears when the system detects that the issue no longer exists.
411		Service Urgent	OU Low Pressure Switch Strikes Lockout	The low pressure switch has opened five times during one cooling or heating demand. <ul style="list-style-type: none"> • Thermostat will shut down the outdoor unit. • Open low pressure switch error count reached five strikes. • Check system charge using both approach and sub-cooling methods. • Reset by putting outdoor unit control in test mode or resetting low voltage power. 	Automatically clears when the system detects that the issue no longer exists.
412		Information Only-Dealer	OU Open High Pressure Switch	The unit high pressure is above the upper limit. <ul style="list-style-type: none"> • System will shut down. • Confirm that the system is properly charged with refrigerant. • Check condenser fan motor, expansion valve (if installed), indoor unit blower motor, stuck reversing valve or clogged refrigerant filter. • Confirm that the outdoor unit is clean. 	Automatically clears after the high pressure switch closes or a power reset
413		Service Urgent	OU High Pressure Switch Strikes Lockout	The high pressure switch has opened five times during one cooling demand. <ul style="list-style-type: none"> • Thermostat will shut down the outdoor unit. • Open high pressure switch error count reached five strikes. • Check system charge using superheat and sub-cooling temperatures. • Check outdoor fan operation. • Check for dirt or debris blocking air flow to outdoor unit. • Reset by putting outdoor unit control in test mode or resetting low voltage power. 	Automatically clears when the system detects that the issue no longer exists.

Table 22. Lennox® S40 Smart Thermostat Alert Codes and Troubleshooting

E2A=Errors to Action, GF= Gas Furnace, AH=Air Handler, IU=Indoor unit (GF or AH), HP=Heat Pump, AC=Air Conditioner, OU=Outdoor Unit (AC or HP), PA=Pure Air S, ZA=Zone system, SRS=Smart Room Sensor, TS=Thermostat , IAQ- IAQ Monitor and WE=Wi-Fi Extender

Alert Code	Inverter Flash Code	Priority Condition	Actual Displayed Alert Text Under dealer control center > Notifications	Component or System Operational State and Troubleshooting Tip	How to clear alert code
414		Service Soon	OU High Discharge Line Temperature	<p>The discharge line temperature is higher than the recommended upper limit of 279°F.</p> <ul style="list-style-type: none"> Discharge line temperature is greater than 279°F. Make sure coil is clean and airflow unobstructed in and out of condenser. Check system operating pressures and compare to unit charging charts in installation manual. 	Automatically clears after discharge temperature is less than 225°F.
415		Service Urgent	OU High Discharge Line Temp Strikes Lockout	<p>The discharge line temperature has been consistently higher than the recommended upper limit of 279°F.</p> <ul style="list-style-type: none"> Discharge line high temperature error count reached five strikes during a single demand. Make sure coil is clean and airflow unobstructed in and out of condenser. Check system charge using superheat and sub cooling temperatures. Reset by putting outdoor control in test mode or resetting low voltage power. 	Correct issue and cycle power to the system.
416		Service Soon	OU Coil Sensor Faulty	<p>The outdoor coil sensor is either open, short-circuited, or the temperature is out of sensor range.</p> <ul style="list-style-type: none"> Outdoor unit control will not perform demand or time / temperature defrost operation. (System will still heat or cool.) This fault is detected by allowing the unit to run for 90 seconds before checking sensor resistance. If the sensor resistance is not within range after 90 seconds, the control will display a service soon condition. Plug-in sensor harness correctly. Check resistance of sensor to determine if it is open, shorted, out of temperature calibration or out of ambient temperature range. Replace if out-of-specifications. 	Automatically clears when outdoor unit control detects proper sensor readings. Reset power to clear alert code.

Table 22. Lennox® S40 Smart Thermostat Alert Codes and Troubleshooting

E2A=Errors to Action, GF= Gas Furnace, AH=Air Handler, IU=Indoor unit (GF or AH), HP=Heat Pump, AC=Air Conditioner, OU=Outdoor Unit (AC or HP), PA=Pure Air S, ZA=Zone system, SRS=Smart Room Sensor, TS=Thermostat , IAQ- IAQ Monitor and WE=Wi-Fi Extender

Alert Code	Inverter Flash Code	Priority Condition	Actual Displayed Alert Text Under dealer control center > Notifications	Component or System Operational State and Troubleshooting Tip	How to clear alert code
417		Service Soon	OU Discharge Sensor Faulty	<p>System Detection and Operation:</p> <p>The outdoor unit discharge line temperature sensor is either open, short-circuited, or the temperature is out of sensor range.</p> <ul style="list-style-type: none"> • This fault is detected by allowing the unit to run for 90 seconds before checking discharge line sensor resistance. • If the discharge sensor resistance is not within range after 90 second period, the control will display the priority condition as service soon. • If the service soon condition continues for 10 minutes, the system changes the priority condition to service urgent. <p>Possible Causes:</p> <ul style="list-style-type: none"> • The applicable system component detects either an open, shorted or temperature out of range condition. • Discharge sensor leads located in wrong pin positions in harness plug-in connector. Refer to the applicable unit installation and service procedure and locate the terminal descriptions table to verify cable harness assembly wiring pin positions are correct. <p>Possible Solutions:</p> <ul style="list-style-type: none"> • Check the resistance of the discharge sensor and compare to temperature resistance chart located in the applicable unit installation and service procedure. If sensor resistance is out of range then replace the discharge line temperature sensor. • If discharge sensor wiring leads are located in the wrong connector pin-out then order a replacement cable assembly. 	Automatically clears after fault signal condition is no longer present.
418		Service Soon	OU EIM W Output Hardware Fault	<p>There is a faulty W output circuit.</p> <ul style="list-style-type: none"> • W terminal is energized while in cooling mode. • Possible cause may be a stuck closed relay on the control, or something external to the control that is energizing W terminal when it should not be energized. • Disconnect any wiring from the W terminal. • If 24VAC is still present on the terminal, then it is a stuck relay. • If 24VAC disappears, then there is a need to check any of the wires hooked up to the W terminal. 	Automatically clears after fault signal is removed.
419		Service Urgent	OU EIM W Output Hardware Fault Lockout	<p>The W output has reported more than five errors.</p> <ul style="list-style-type: none"> • The system will shut down the outdoor unit. • The W output (alert code 418) on the outdoor unit has reported more than five strikes. • Disconnect thermostat wire from W and verify there is no 24VAC on the W. • If 24VAC is present, replace the outdoor control. 	Automatically clears after power recycled.

Table 22. Lennox® S40 Smart Thermostat Alert Codes and Troubleshooting

E2A=Errors to Action, GF= Gas Furnace, AH=Air Handler, IU=Indoor unit (GF or AH), HP=Heat Pump, AC=Air Conditioner, OU=Outdoor Unit (AC or HP), PA=Pure Air S, ZA=Zone system, SRS=Smart Room Sensor, TS=Thermostat , IAQ- IAQ Monitor and WE=Wi-Fi Extender

Alert Code	Inverter Flash Code	Priority Condition	Actual Displayed Alert Text Under dealer control center > Notifications	Component or System Operational State and Troubleshooting Tip	How to clear alert code
420		Service Soon	AH EIM Defrost Out Of Cycle	<p>The heat pump defrost cycle has taken more than 20 minutes to complete.</p> <ul style="list-style-type: none"> Defrost cycle lasts longer than 20 minutes. Check heat pump operation. This is applicable only in communicating indoor unit with non-communicating heat pump. 	Automatically clears when W1 signal is removed.
421		Service Urgent	OU EIM W External Miswire Fault	The W output terminal on the outdoor unit is not wired correctly. Voltage sensed on W output terminal when Y1 out is deactivated.	Automatically clears once voltage is not sensed on output or power is cycled.
422		Service Soon	OU Compressor Top Cap Switch Open	<p>Compressor top cap switch exceeding thermal limit.</p> <ul style="list-style-type: none"> Check condenser fan motor, TXV and indoor unit blower motor. Check for stuck reversing valve or clogged refrigerant filter. Lennox Variable Capacity Outdoor Units: Check to ensure that one of the wires from the top cap switch has not been disconnected from one of the TP terminals on the outdoor control. Reconnect wire if disconnected. Check superheat and sub-cooling. 	Automatically clears when error is corrected.
423	40	Service Soon / Service Urgent	OU Inverter CT Circuit Fault	<p>The inverter has detected a circuit issue.</p> <ul style="list-style-type: none"> When this condition is detected the outdoor control will stop outdoor unit operations and start the anti-short cycle timer – service soon condition. Outdoor control will lockout unit after 10 strikes within an hour – service urgent condition. Inverter LEDs will flash code 40 Refer to the unit service documentation for troubleshooting procedures. <p>Inverter flash code 40</p> <p>The sequence is: Red LED: Four Flashes Green LED: Off</p> <p>NOTE: <i>Inverter normal operations with no error code present is as follows. Red LED is ON and Green LED is OFF.</i></p>	<p>A service soon alert code will clear automatically when the inverter detects the condition no longer exist and will send a clear alert code message.</p> <p>To clear service urgent alert code disconnect power to outdoor unit and restart.</p>
424		Service Soon	OU Liquid Line Sensor Faulty	<p>The liquid line temperature sensor has malfunctioned.</p> <ul style="list-style-type: none"> In normal operation after outdoor control recognizes sensors, the alert code will be sent if a valid temperature reading is lost. Compare liquid line sensor resistance to temperature / resistance charts in unit installation instructions. Replace sensor pack if necessary. At the beginning of (any) configuration, furnace or air handler control will detect the presence of the sensor(s). If detected (reading in range), appropriate feature will be set as 'installed' and shown in the thermostat 'About' screen. 	Automatically clears upon configuration, or sensing normal values.

Table 22. Lennox® S40 Smart Thermostat Alert Codes and Troubleshooting

E2A=Errors to Action, GF= Gas Furnace, AH=Air Handler, IU=Indoor unit (GF or AH), HP=Heat Pump, AC=Air Conditioner, OU=Outdoor Unit (AC or HP), PA=Pure Air S, ZA=Zone system, SRS=Smart Room Sensor, TS=Thermostat , IAQ- IAQ Monitor and WE=Wi-Fi Extender

Alert Code	Inverter Flash Code	Priority Condition	Actual Displayed Alert Text Under dealer control center > Notifications	Component or System Operational State and Troubleshooting Tip	How to clear alert code
426		Service Urgent	OU Excessive Inverter Alarms	After 10 faults within 60 consecutive minutes, the control will lockout. Inverter will flash codes 12 to 14 and 53. NOTE: <i>These inverter codes do not count towards this lockout condition.</i>	To clear disconnect power to outdoor control and restart
427	21	Service Soon / Service Urgent	OU Inverter DC Peak Fault	The inverter has detected a DC peak fault condition. <ul style="list-style-type: none"> • If condition (55A or higher) is detected, outdoor unit will stop (compressor and fan) – service soon condition. • Anti-short cycle is initiated. • If peak current (55A or higher) occurs 10 times within an hour, system will lockout – service urgent condition. • Inverter LEDs will flash code 21. • If the unit is a Lennox variable capacity heat pump, this error may occur entering or exiting a defrost cycle as the compressor restarts after the 30 second compressor shift delay. If the unit was manufactured prior to serial number 5817F and has frequent alert code 427, then compare the inverter part number to the latest part number listed in the unit repair parts. Units produced after serial number 5817F which is listed on the unit name plate have an inverter with updated software that includes compressor current slope logic to reduce the potential of alert code 427 instances from occurring during defrost. Replace the inverter with the latest inverter if necessary. • Refer to the unit service documentation for detailed troubleshooting procedures. NOTE: <i>Serial number format on unit name plate is PPYYMNNNNN (PP = Manufacturing Plant, YY and M represents the year and month made.</i> Inverter flash code 21 The sequence is: <ul style="list-style-type: none"> • Red LED: Two Flashes • Green LED: One Flash NOTE: <i>Inverter normal operations with no error code present is as follows. Red LED is ON and Green LED is OFF.</i>	To clear, disconnect and reconnect power to outdoor control.

Table 22. Lennox® S40 Smart Thermostat Alert Codes and Troubleshooting

E2A=Errors to Action, GF= Gas Furnace, AH=Air Handler, IU=Indoor unit (GF or AH), HP=Heat Pump, AC=Air Conditioner, OU=Outdoor Unit (AC or HP), PA=Pure Air S, ZA=Zone system, SRS=Smart Room Sensor, TS=Thermostat , IAQ- IAQ Monitor and WE=Wi-Fi Extender

Alert Code	Inverter Flash Code	Priority Condition	Actual Displayed Alert Text Under dealer control center > Notifications	Component or System Operational State and Troubleshooting Tip	How to clear alert code
428	22	Service Soon / Service Urgent	OU Inverter High Main Input Current	<p>The inverter has detected a high main input current condition.</p> <ul style="list-style-type: none"> • If condition is detected, outdoor unit will stop (compressor and fan) – service soon condition. • Anti-short cycle is initiated. • If condition occurs 10 times within an hour, system will lockout – service urgent condition. • Inverter LEDs will flash code 22. • Refer to the unit service documentation for detailed troubleshooting procedures. <p>Inverter flash code 22</p> <p>The sequence is:</p> <ul style="list-style-type: none"> • Red LED: Two Flashes • Green LED: Two Flashes <p>NOTE: <i>Inverter normal operations with no error code present is as follows. Red LED is ON and Green LED is OFF.</i></p>	To clear, disconnect power to outdoor unit and restart.

Table 22. Lennox® S40 Smart Thermostat Alert Codes and Troubleshooting

E2A=Errors to Action, GF= Gas Furnace, AH=Air Handler, IU=Indoor unit (GF or AH), HP=Heat Pump, AC=Air Conditioner, OU=Outdoor Unit (AC or HP), PA=Pure Air S, ZA=Zone system, SRS=Smart Room Sensor, TS=Thermostat , IAQ- IAQ Monitor and WE=Wi-Fi Extender

Alert Code	Inverter Flash Code	Priority Condition	Actual Displayed Alert Text Under dealer control center > Notifications	Component or System Operational State and Troubleshooting Tip	How to clear alert code
429	23	Service Soon / Service Urgent	OU Inverter DC Link Low Voltage	<p>The inverter has detected a DC link low voltage condition.</p> <ul style="list-style-type: none"> On a call for compressor operation, if DC link power in inverter does not rise above 180 VDC for 2- and 3-ton models, 250 VDC for 4- and 5-ton models within 30 seconds, the control will display a service soon code. If condition is detected, outdoor unit will stop (compressor and fan) – service soon condition. An anti-short cycle timer is initiated. If condition occurs 10 times within a 60 consecutive minutes, system will lock out and display alert code 429 – service urgent condition. The outdoor control anti-short cycle timer will time out and the unit will recycle the demand. Inverter LEDs will flash code 23. Refer to the unit service documentation for detailed troubleshooting procedures. Perform test function and verify inverter DC link and line input voltage and current. Also check input to filter board and reactor before replacing inverter board. To perform this test, go to Menu > Settings > Advanced Settings > View Support Service Control Center > Tests. <p>Inverter flash code 23</p> <p>The sequence is:</p> <ul style="list-style-type: none"> Red LED: Two Flashes Green LED: Three Flashes <p>NOTE: <i>Inverter normal operations with no error code present is as follows. Red LED is ON and Green LED is OFF.</i></p> <p>Troubleshooting Suggestions:</p> <ul style="list-style-type: none"> Check wire connections (U, V and W) at inverter plug in harness and compressor. Check the resistance of compressor windings. If not in range, replace compressor. Check compressor to ground. If ground issue, replace compressor. Check input power (Single Phase - 208/230VAC ± 10%. If out of range, correct main power issue. Check DC Link voltage and MICOM Sensing voltage. If out of range, replace inverter. if okay, possible mechanical issue with compressor. <p>Go to outdoor unit service manual for detail troubleshooting procedures and require values for testing DC link voltages and various insulation resistance characteristics.</p>	Automatically clears when the system detects that the issue no longer exists.

Table 22. Lennox® S40 Smart Thermostat Alert Codes and Troubleshooting

E2A=Errors to Action, GF= Gas Furnace, AH=Air Handler, IU=Indoor unit (GF or AH), HP=Heat Pump, AC=Air Conditioner, OU=Outdoor Unit (AC or HP), PA=Pure Air S, ZA=Zone system, SRS=Smart Room Sensor, TS=Thermostat , IAQ- IAQ Monitor and WE=Wi-Fi Extender

Alert Code	Inverter Flash Code	Priority Condition	Actual Displayed Alert Text Under dealer control center > Notifications	Component or System Operational State and Troubleshooting Tip	How to clear alert code
430	26	Service Soon / Service Urgent	OU Inverter Compressor Startup Fail	<p>Compressor start-up failure.</p> <ul style="list-style-type: none"> • If condition is detected, outdoor unit will stop (compressor and fan) – service soon condition. • Anti-short cycle is initiated. • If condition occurs 10 times within 60 consecutive minutes, the system will lockout – service urgent condition. • Inverter LEDs will flash code 26. • Refer to the unit service documentation for detailed troubleshooting procedures. <p>Inverter flash code 26</p> <p>The sequence is:</p> <ul style="list-style-type: none"> • Red LED: Two Flashes • Green LED: Six Flashes <p>NOTE: <i>Inverter normal operations with no error code present is as follows. Red LED is ON and Green LED is OFF.</i></p> <ul style="list-style-type: none"> • Check refrigerant • Replace outdoor control board • Replace inverter. 	To clear, disconnect power to outdoor unit and restart.
431	27	Service Soon / Service Urgent	OU Inverter PFC Fault	<p>The inverter has detected a PFC circuit over-current condition.</p> <ul style="list-style-type: none"> • Error occurs when PFC detects an over current condition of 100A peak. • If condition is detected, outdoor unit will stop (compressor and fan) – service soon condition. • Anti-short cycle timer is initiated. • If condition occurs 10 times within 60 consecutive minutes, the system will lockout – service urgent condition. • Inverter LEDs will flash code 27. • Refer to the unit service documentation for detailed troubleshooting procedures. <p>Inverter flash code 27</p> <p>The sequence is:</p> <ul style="list-style-type: none"> • Red LED: Two Flashes • Green LED: Seven Flashes <p>NOTE: <i>Inverter normal operations with no error code present is as follows. Red LED is ON and Green LED is OFF.</i></p>	To clear, disconnect power to outdoor unit and restart.

Table 22. Lennox® S40 Smart Thermostat Alert Codes and Troubleshooting

E2A=Errors to Action, GF= Gas Furnace, AH=Air Handler, IU=Indoor unit (GF or AH), HP=Heat Pump, AC=Air Conditioner, OU=Outdoor Unit (AC or HP), PA=Pure Air S, ZA=Zone system, SRS=Smart Room Sensor, TS=Thermostat , IAQ- IAQ Monitor and WE=Wi-Fi Extender

Alert Code	Inverter Flash Code	Priority Condition	Actual Displayed Alert Text Under dealer control center > Notifications	Component or System Operational State and Troubleshooting Tip	How to clear alert code
432	28	Service Soon / Service Urgent	OU Inverter DC Link High Voltage	<p>The inverter has detected a DC link high voltage condition.</p> <ul style="list-style-type: none"> • Error occurs when the DC link capacitor voltage is greater than 480 VDC. • If condition is detected, outdoor unit will stop (compressor and fan) – service soon condition. • Anti-short cycle timer is initiated. • If condition occurs 10 times within 60 consecutive minutes, the system will lockout – service urgent condition. • Inverter LEDs will flash code 28. • Refer to the unit service documentation for detailed troubleshooting procedures. <p>Inverter flash code 28</p> <p>The sequence is:</p> <ul style="list-style-type: none"> • Red LED: Two Flashes • Green LED: Eight Flashes <p>NOTE: <i>Inverter normal operations with no error code present is as follows. Red LED is ON and Green LED is OFF.</i></p> <p>Troubleshooting Suggestions:</p> <ul style="list-style-type: none"> • Check wire connections (U, V and W) at inverter plug in harness and compressor. • Check the resistance of compressor windings. If not in range, replace compressor. • Check compressor to ground. If ground issue, replace compressor. • Check input power (Single Phase - 208/230VAC ± 10%. If out of range, correct main power issue. • Check DC Link voltage and MICOM Sensing voltage. If out of range, replace inverter. if okay, possible mechanical issue with compressor. <p>Go to outdoor unit service manual for detail troubleshooting procedures and require values for testing DC link voltages and various insulation resistance characteristics.</p>	To clear, disconnect power to outdoor unit and restart.

Table 22. Lennox® S40 Smart Thermostat Alert Codes and Troubleshooting

E2A=Errors to Action, GF= Gas Furnace, AH=Air Handler, IU=Indoor unit (GF or AH), HP=Heat Pump, AC=Air Conditioner, OU=Outdoor Unit (AC or HP), PA=Pure Air S, ZA=Zone system, SRS=Smart Room Sensor, TS=Thermostat , IAQ- IAQ Monitor and WE=Wi-Fi Extender

Alert Code	Inverter Flash Code	Priority Condition	Actual Displayed Alert Text Under dealer control center > Notifications	Component or System Operational State and Troubleshooting Tip	How to clear alert code
433	29	Service Soon / Service Urgent	OU Inverter Compressor Over-current	<p>Compressor phase current is too high.</p> <ul style="list-style-type: none"> • During initial startup, a six minute time delay is implement to prevent the alarm from occurring. • Error occurs when compressor peak phase current is greater than 28 amps. • Inverter will issue inverter code 14 first and slow down to try to reduce the current. • If the current remains high, outdoor unit will stop (compressor and fan) – service soon condition. • Cycle timer is initiated. • If condition occurs five times within 60 consecutive minutes, the system will lockout – service urgent condition. • This alert code may be triggered by the inverter or the Lennox variable capacity outdoor (inverter controlled) unit. • Lennox outdoor control may trigger an this alert code if the inverter reduces the compressor speed which is identified as a alert code 441 and the compressor speed (in hz) is below the minimum speed. This will typically occur at start-up. The inverter automatically increases the compressor minimum speed below 45°F in the heating mode and above 115°F ensure the compressor capacity is sufficient for oil return. If alert code 433 occurs and inverter does not indicate an inverter code 29, the Lennox communicating Lennox outdoor control triggered the alert code 433. <p>> Check the Lennox outdoor control software version by accessing the outdoor unit diagnostics section of the Lennox communicating thermostat. The Lennox outdoor control with software versions 1.27 and later have updated software that includes a six minute time delay during the cooling mode and a 11 minute delay during the heating mode after receiving an alert code 433, which typically occurs during start-up.</p> <p>> If the system is connected to the Internet, the Lennox outdoor control can be updated over the Internet. Make sure the software “auto update” is enabled. The software “auto update” can be toggled to prompt the Lennox server to update the thermostat which will update the Lennox outdoor control. If the system is not connected to the Internet, replace the Lennox outdoor control with catalog number 17D27 or newer version.</p> <ul style="list-style-type: none"> • Inverter LEDs will flash code 29. • Refer to the unit service documentation for detailed troubleshooting procedures. <p>Inverter flash code 29</p> <p>The sequence is:</p> <ul style="list-style-type: none"> • Red LED: Two Flashes • Green LED: Nine Flashes <p>NOTE: <i>Inverter normal operations with no error code present is as follows. Red LED is ON and Green LED is OFF.</i></p>	To clear alert code disconnect power to both the indoor and outdoor units and then reconnect power. Restart system.

Table 22. Lennox® S40 Smart Thermostat Alert Codes and Troubleshooting

E2A=Errors to Action, GF= Gas Furnace, AH=Air Handler, IU=Indoor unit (GF or AH), HP=Heat Pump, AC=Air Conditioner, OU=Outdoor Unit (AC or HP), PA=Pure Air S, ZA=Zone system, SRS=Smart Room Sensor, TS=Thermostat , IAQ- IAQ Monitor and WE=Wi-Fi Extender

Alert Code	Inverter Flash Code	Priority Condition	Actual Displayed Alert Text Under dealer control center > Notifications	Component or System Operational State and Troubleshooting Tip	How to clear alert code
434	53	Service Soon / Service Urgent	OU Inverter Communication Error to Main Control	<ul style="list-style-type: none"> Outdoor control has lost communications with the inverter continuously during a single thermostat call and one hour period. Outdoor control will stop all compressor demands – service soon condition. Indoor blower will stop functioning. <p>NOTE: <i>Indoor blower will not run in test mode either when alert code 434 is active. Only after system reset will it operate.</i></p> <ul style="list-style-type: none"> This alert code will occur if the outdoor unit power is turned off and the indoor unit power (24VAC to Lennox outdoor control) remains on, or if the indoor unit power is turned off (24VAC to Lennox outdoor control) and the outdoor unit power is on. This could occur while performing service or maintenance procedures on the indoor or outdoor unit. The Lennox outdoor control will attempt to re-establish communication to the inverter when the alert code 434 occurs by cycling the outdoor unit contactor off for two minutes. Upon energizing the contactor the Lennox outdoor control will attempt to communicate to the inverter for three minutes. This process will be repeated three times in attempt to establish communication before locking out. If the unit is locked out with a service urgent alert code 434, reset the system by cycling the outdoor unit power off and back on. Then cycle the indoor power off (24VAC to the Lennox outdoor control) and then back on. If this condition continuously occurs during a one hour period and during a single thermostat call, the outdoor unit will lock out and display alert code 434 – service urgent condition. <p>Troubleshooting Options:</p> <ul style="list-style-type: none"> Check for loose or disconnected electrical connections. Interruption of main power to inverter. Inverter LEDs will flash code 53. Refer to the unit service documentation for detailed troubleshooting procedures. <p>Inverter flash code 53</p> <p>The sequence is:</p> <ul style="list-style-type: none"> Red LED: Five Flashes Green LED: Three Flashes <p>NOTE: <i>Inverter normal operations with no error code present is as follows. Red LED is ON and Green LED is OFF</i></p>	<p>Automatically clears when the system detects that the issue no longer exists.</p> <p>If the unit is locked out with a service urgent alert code 434, reset the system by first cycling the outdoor unit power off and back. Then cycle the indoor power off (24VAC to the Lennox outdoor control) and then back on.</p>

Table 22. Lennox® S40 Smart Thermostat Alert Codes and Troubleshooting

E2A=Errors to Action, GF= Gas Furnace, AH=Air Handler, IU=Indoor unit (GF or AH), HP=Heat Pump, AC=Air Conditioner, OU=Outdoor Unit (AC or HP), PA=Pure Air S, ZA=Zone system, SRS=Smart Room Sensor, TS=Thermostat , IAQ- IAQ Monitor and WE=Wi-Fi Extender

Alert Code	Inverter Flash Code	Priority Condition	Actual Displayed Alert Text Under dealer control center > Notifications	Component or System Operational State and Troubleshooting Tip	How to clear alert code
435	60	Service Soon / Service Urgent	OU Inverter EEPROM Checksum fault	<p>Inverter internal error.</p> <ul style="list-style-type: none"> When this error occurs, the outdoor control will cycle power to the inverter by opening the contactor for two minutes – service soon condition. Outdoor control will cycle power to the inverter three times and then outdoor unit is locked out – service urgent condition. Inverter LEDs will flash code 60. Refer to the unit service documentation for detailed troubleshooting procedures. <p>Inverter flash code 60</p> <p>The sequence is:</p> <ul style="list-style-type: none"> Red LED: Six Flashes Green LED: Off <p>NOTE: Inverter normal operations with no error code present is as follows. Red LED is ON and Green LED is OFF.</p>	To clear alert code disconnect power to outdoor unit and restart.
436	62	Service Soon / Service Urgent	OU Inverter High Heat-Sink Temperature	<p>Inverter heat sink temperature exceeded limit.</p> <ul style="list-style-type: none"> This occurs when the heat sink temperature exceeds the inverter limit. Inverter will issue inverter alert code 13 first and slow down to try to cool the heat sink. If temperature remains high, outdoor unit will stop both compressor and fan – service soon condition. Anti-short cycle is initiated. If condition occurs five times within an hour, system will lockout – service urgent condition. The screws that hold the inverter to the inverter board were loose causing poor contact between these two components. Tighten screws that hold the heat sink to the inverter control board. <p>NOTE: Wait five minutes for all capacitors to discharge before checking screws.</p> <ul style="list-style-type: none"> Inverter LEDs will flash code 62. Refer to the unit service documentation for detailed troubleshooting procedures. <p>Inverter flash code 62</p> <p>The sequence is:</p> <ul style="list-style-type: none"> Red LED: Six Flashes Green LED: Two Flashes <p>NOTE: Inverter normal operations with no error code present is as follows. Red LED is ON and Green LED is OFF.</p>	Service soon condition will automatically clear when the inverter sends an alert code clear message. Service urgent condition is cleared by disconnecting power to the outdoor unit and restart.

Table 22. Lennox® S40 Smart Thermostat Alert Codes and Troubleshooting

E2A=Errors to Action, GF= Gas Furnace, AH=Air Handler, IU=Indoor unit (GF or AH), HP=Heat Pump, AC=Air Conditioner, OU=Outdoor Unit (AC or HP), PA=Pure Air S, ZA=Zone system, SRS=Smart Room Sensor, TS=Thermostat , IAQ- IAQ Monitor and WE=Wi-Fi Extender

Alert Code	Inverter Flash Code	Priority Condition	Actual Displayed Alert Text Under dealer control center > Notifications	Component or System Operational State and Troubleshooting Tip	How to clear alert code
437	65	Service Soon / Service Urgent	OU Inverter Heat-Sink temp Sensor Fault	<p>Heat sink temperature sensor fault has occurred (temperature less than 4°F or greater than 264°F after 10 minutes of operation).</p> <ul style="list-style-type: none"> When the temperature sensor detects a temperature less than 4°F or greater than 264°F after 10 minutes of operation. Outdoor unit will stop both compressor and fan – service soon condition. Anti-short cycle is initiated. If condition occurs five times within an hour, system will lockout – service urgent condition. Inverter LEDs will flash code 65. Refer to the unit service documentation for detailed troubleshooting procedures. <p>Inverter flash code 65</p> <p>The sequence is:</p> <ul style="list-style-type: none"> Red LED: Six Flashes Green LED: Five Flashes <p>NOTE: Inverter normal operations with no error code present is as follows. Red LED is ON and Green LED is OFF.</p>	<p>Service soon priority condition will automatically clear when the inverter sends an alert code clear message. Service urgent priority condition can be cleared by disconnecting and reconnecting power to outdoor unit to restart.</p>
438	73	Service Soon / Service Urgent	OU Inverter PFC Input Overcurrent	<p>The inverter has detected a power factor correction (PFC) circuit over-current condition.</p> <ul style="list-style-type: none"> The inverter has detected an PFC over current condition. This may be caused by a high load condition, high pressure, or outdoor fan failure. Outdoor control will display the code when the inverter has detected the error – service soon condition. After three minutes, the inverter will reset and the compressor will resume operation. If the error condition occurs 10 times within a 60 minute rolling time period, the outdoor unit control will lock out operation of the outdoor unit – service urgent condition. Possible issue is system running at high pressures. Check for high pressure trips or other alert codes in thermostat and outdoor control. Inverter LEDs will flash code 73. Refer to the unit service documentation for detailed troubleshooting procedures. <p>Inverter flash code 73</p> <p>The sequence is:</p> <ul style="list-style-type: none"> Red LED: Seven Flashes Green LED: Three Flashes <p>NOTE: Inverter normal operations with no error code present is as follows. Red LED is ON and Green LED is OFF.</p>	<p>Service soon priority condition is automatically cleared when the inverter sends a clear message. Service urgent priority condition will automatically clear when inverter is power cycled.</p>

Table 22. Lennox® S40 Smart Thermostat Alert Codes and Troubleshooting

E2A=Errors to Action, GF= Gas Furnace, AH=Air Handler, IU=Indoor unit (GF or AH), HP=Heat Pump, AC=Air Conditioner, OU=Outdoor Unit (AC or HP), PA=Pure Air S, ZA=Zone system, SRS=Smart Room Sensor, TS=Thermostat , IAQ- IAQ Monitor and WE=Wi-Fi Extender

Alert Code	Inverter Flash Code	Priority Condition	Actual Displayed Alert Text Under dealer control center > Notifications	Component or System Operational State and Troubleshooting Tip	How to clear alert code
440	13	Information Only-Dealer	OU Inverter Compressor Slowdown - High Heat-Sink Temperature	<p>Compressor slowdown due to high heat sink temperature.</p> <ul style="list-style-type: none"> Heat sink temperature is approaching limit. The compressor speed automatically slows to reduce heat sink temperature. The control sets indoor CFM and outdoor RPM to values according to demand percentage rather than the actual Hz. The screws that hold the inverter to the inverter board may be loose causing poor contact between these two components. Tighten screws that hold the heat sink to the inverter control board. <p>NOTE: Wait five minutes for all capacitors to discharge before checking screws.</p> <ul style="list-style-type: none"> This error code is primarily for informational purposes as the inverter controls the compressor speed to operate within design parameters. Typically the inverter will make a minor speed reduction of 4 Hz (approximately a 5-6% speed reduction) for a brief period of time and to reduce the heat sink temperature and will then resume normal operation. This may occur at high outdoor temperatures (above 110°F) for brief periods of time (3 – 4 minutes) and is normal and expected operation of the inverter controlling the compressor safely within design parameters. The inverter finned aluminium heat sink is located on the back side of the inverter in the condenser air stream. If the alert code 440 occur frequently, especially at lower outdoor temperatures, check the heat sink for debris that may reduce heat transfer or possible obstructions that may impact air flow across the heat sink. The inverter will begin to briefly reduce the compressor speed when the heat sink temperature rises above 185°F and will allow the inverter to resume the requested compressor demand speed once the inverter heat sink reaches 176°F. The heat sink temperature, compressor speed in Hertz & the Inverter Compressor Speed Reduction status (“On” or “Off”) notification can be viewed under the outdoor unit Diagnostics section of the thermostat dealer control center. Inverter LEDs will flash code 13. Refer to the unit service documentation for detailed troubleshooting procedures. <p>Inverter flash code 13.</p> <p>The sequence is:</p> <ul style="list-style-type: none"> Red LED: One Flash Green LED: Three Flashes <p>NOTE: Inverter normal operations with no error code present is as follows. Red LED is ON and green LED is OFF.</p>	Automatically clears when the condition no longer exists.

Table 22. Lennox® S40 Smart Thermostat Alert Codes and Troubleshooting

E2A=Errors to Action, GF= Gas Furnace, AH=Air Handler, IU=Indoor unit (GF or AH), HP=Heat Pump, AC=Air Conditioner, OU=Outdoor Unit (AC or HP), PA=Pure Air S, ZA=Zone system, SRS=Smart Room Sensor, TS=Thermostat , IAQ- IAQ Monitor and WE=Wi-Fi Extender

Alert Code	Inverter Flash Code	Priority Condition	Actual Displayed Alert Text Under dealer control center > Notifications	Component or System Operational State and Troubleshooting Tip	How to clear alert code
441	14	Information Only-Dealer	OU Inverter Compressor Slowdown - High Compressor Current	<p>This alert code is for more information than an issue with the system.</p> <ul style="list-style-type: none"> When the inverter gets close to the current or heat sink temperature limit, it will limit the ramp rate. Instead of changing compressor speed at 1 hz/second, it changes to 5 hz/20 seconds. Compressor slowdown due to high compressor current. Compressor current is approaching limit. The compressor speed automatically slows. This error code is primarily for informational purposes as the inverter controls the compressor to operate within design parameters. Alert code 441 typically occurs at startup as the compressor current increases rapidly during startup. The inverter will reduce the compressor speed by 4 Hz and slow the compressor ramp up speed to the requested compressor demand speed (capacity). This is normal and expected operation of the inverter to control the inverter within design parameters. In most cases the alert code 441 notification does not require any additional service or diagnostic procedures. The control sets indoor CFM and outdoor RPM to values according to demand percentage rather than the actual Hz. Possible issue is system running at high pressures. Check for high pressure trips or other alert codes in thermostat and outdoor control. Inverter LEDs will flash code 14. Refer to the unit service documentation for detailed troubleshooting procedures. <p>Inverter flash code 14.</p> <p>The sequence is:</p> <ul style="list-style-type: none"> Red LED: One Flash Green LED: Four Flashes <p>NOTE: <i>Inverter normal operations with no error code present is as follows. Red LED is ON and green LED is OFF.</i></p>	Automatically clears when the condition no longer exists.
442		Service Urgent	OU Compressor Top Cap Switch Strikes Lockout	<p>The top cap switch has opened five times within one hour. As a result, the outdoor unit is locked out.</p> <ul style="list-style-type: none"> This condition occurs when compressor thermal protection sensor opens five times within one hour. Outdoor unit will stop. 	To clear, disconnect power to outdoor unit and restart.
443		Service Urgent	OU MUC Unit Code To Inverter Model Mismatch	<p>The Lennox variable capacity unitary control (outdoor control) has incorrect appliance unit size code selected.</p> <ul style="list-style-type: none"> Check for proper configuring under unit size code used for outdoor unit (see unit configuration guide or in installation instructions). If replacing inverter, verify inverter model matches unit size. Remove the thermostat from the system while applying power and reprogramming. 	Automatically clears after the correct match is detected following a power reset.

Table 22. Lennox® S40 Smart Thermostat Alert Codes and Troubleshooting

E2A=Errors to Action, GF= Gas Furnace, AH=Air Handler, IU=Indoor unit (GF or AH), HP=Heat Pump, AC=Air Conditioner, OU=Outdoor Unit (AC or HP), PA=Pure Air S, ZA=Zone system, SRS=Smart Room Sensor, TS=Thermostat , IAQ- IAQ Monitor and WE=Wi-Fi Extender

Alert Code	Inverter Flash Code	Priority Condition	Actual Displayed Alert Text Under dealer control center > Notifications	Component or System Operational State and Troubleshooting Tip	How to clear alert code
444		Service Urgent	HP Reversing Valve Relay or Solenoid Fault	Relay failure. Verify by call for heat pump heating. Check for 24VAC out from O .	Replace Outdoor Unit Control Board
446		Service Soon / Service Urgent	OU Low Suction Pressure Fault	Suction pressure < 40 psig in operation. Error code initially will be a service soon and will escalate to service urgent and stop system operation. After 5-strikes during a single thermostat demand. Recommend replacement of low pressure switch.	Recommend replacement of low pressure switch.
480		Service Soon / Service Urgent	TBD	The EEV control board has stopped communicating with the outdoor control. Heat pump heating operation stopped.	Will automatically clear when the communication between EEV control and unitary control is established, check CAN LED EEV control and verify Green LED is flickering indicating RsBus is communicating.
481		Service Soon	OU Discharge Pressure Transducer Fault	Discharge pressure transducer fault. Discharge pressures sensor signal is out of range. The signal should be between 0.5 and 4.5 Vdc between Blue and Black. .	The error code will be cleared when the proper signal is provided to the control. Injection will be disabled, heating and cooling demands will still be serviced
482		Service Soon	OU Compressor suction temperature sensor fault	<ul style="list-style-type: none"> Compressor Suction Temperature Sensor has malfunctioned. Check temperature sensor resistance in the applicable Installation and Service Procedure Manual. Nominal resistance is 10K ohms at 77°F (25°C). Compressor speed limited to 70 hz. 	Automatically clears after three (3) consecutive readings that are in range
484		Service Soon	OU System EEV power head failure	<ul style="list-style-type: none"> System EEV coil current too low. Heat pump operation can continue. Check system EEV coil connection to EEV controller. 	Check system EEV coil connection to the EEV controller.
485		Service Soon	OU System EEV over current	System EEV coil current too high. Heat pump heating operation stopped.	Check system EEV coil connection to EEV controller.
486		Service Soon	OU System EEV low Superheat	System superheat below 3 degrees F for more than 10 minutes. Heat pump heating operation stopped.	Clears when anti-short cycle timer has expired
487		Service Urgent	OU System EEV high Superheat	System superheat higher than 40 degrees F for more than 10 minutes. Heat pump heating operation stopped.	Automatically clears when superheat is within range during the next heating demand

Table 22. Lennox® S40 Smart Thermostat Alert Codes and Troubleshooting

E2A=Errors to Action, GF= Gas Furnace, AH=Air Handler, IU=Indoor unit (GF or AH), HP=Heat Pump, AC=Air Conditioner, OU=Outdoor Unit (AC or HP), PA=Pure Air S, ZA=Zone system, SRS=Smart Room Sensor, TS=Thermostat , IAQ- IAQ Monitor and WE=Wi-Fi Extender

Alert Code	Inverter Flash Code	Priority Condition	Actual Displayed Alert Text Under dealer control center > Notifications	Component or System Operational State and Troubleshooting Tip	How to clear alert code
489		Service Soon	OU liquid injection EEV stepper motor failure	<ul style="list-style-type: none"> Injection EEV coil current too low. Injection operation stopped, heat pump heating can continue. Check injection EEV coil connection to the EEV controller. Check liquid injection EEV stepper motor resistance and replace if the range is out of spec 	Automatically clears when the system detects the issue is no longer present.
490		Service Soon	OU liquid injection EEV over current	<ul style="list-style-type: none"> Injection EEV coil current too high. Injection operation stopped, heat pump heating can continue. Check injection EEV coil connection to the EEV controller. Check liquid injection EEV stepper motor resistance and replace if the range is out of spec 	Automatically clears when the system detects the issue is no longer present
500		Service Soon	PA Differential Pressure Sensor Fault	<ul style="list-style-type: none"> Pressure sensor reports a fault for more than 5 minutes, or does not respond for more than 5 minutes. Device will not perform any pressure reading calculations until fault is recovered. Remaining filter life display will indicate “-“ while fault exists. 	Automatically clears 30 seconds after fault is recovered.
501		Service Soon	PA UV Sensor Fault	<ul style="list-style-type: none"> Ultra-violet (UV) sensor reports a fault for more than 5 minutes or UV sensor does not respond for more than 5 minutes. Device will not perform any UV lamp life remaining calculations until fault has recovered. Life remaining display shall indicate “-“ while fault exists. 	Automatically clears 30 seconds after fault is recovered.
502		Service Soon	PA UV Lamp Off	The light is determined to be off when the last three last light intensities measurements are below the set threshold.	Light is determined on after 1 set of five samples are above the set threshold.
503		Service Soon	PA Filter Life At 10%	Filter life remaining determined to be <=10%, but greater than 0%.	None
504		Service Soon	PA Filter Life At 0%	Filter life remaining determined to be 0%.	None
505		Service Soon	PA Model Selection Changed	Model Selection jumper has changed positions.	Jumper repositioned back to original jumper position or system rebooted.
506		Service Soon	PA Lamp At 0% life	Ultra violet lamp life is at 0%.	None
507		Service Soon	PA Filter Calibration Failure	<ul style="list-style-type: none"> Filter calibration determined failed due to all test cfm static pressures reading <= 7 Pa. Send alert code immediately. No filter tests or life calculation occur while this alert code is active. 	Clear alert code upon initiation of another filter calibration.
530		Service Soon	ZS Low Damper 24VAC Voltage	<ul style="list-style-type: none"> Check 24VAC voltage to all dampers. Check 24VAC damper transformer. Check connections. 	Replace transformer if applicable.

Table 22. Lennox® S40 Smart Thermostat Alert Codes and Troubleshooting

E2A=Errors to Action, GF= Gas Furnace, AH=Air Handler, IU=Indoor unit (GF or AH), HP=Heat Pump, AC=Air Conditioner, OU=Outdoor Unit (AC or HP), PA=Pure Air S, ZA=Zone system, SRS=Smart Room Sensor, TS=Thermostat , IAQ- IAQ Monitor and WE=Wi-Fi Extender

Alert Code	Inverter Flash Code	Priority Condition	Actual Displayed Alert Text Under dealer control center > Notifications	Component or System Operational State and Troubleshooting Tip	How to clear alert code
532		Information Only-Dealer	ZS Zoning Pressure Switch Opened (High Pressure)	<p>Zoning Pressure Switch Opened (high pressure).</p> <ul style="list-style-type: none"> Compressor pressure is above the specified limit. Compressor is turned off. Zoning will be restored once the high pressure switch closes. <p>Occasionally we get this with an air conditioner systems and the fix is to just jump out the pressure switch terminals on the damper control module board.</p>	Automatically clears after compressor pressure is within limits.
542		Service Soon	ZS Zone 1 Temp Sensor Fault	<p>Possible Causes:</p> <ul style="list-style-type: none"> Zone temperature sensor reading out of range. Check for loose or incorrectly wired connections at the zone sensor or damper control module terminals. Open or short zone temperature sensor detected for more than five second. More than one zone sensor has the same assigned zone number. Check zone sensor(s) zone number assignment. <p>System Response:</p> <ul style="list-style-type: none"> Both types of zone sensors will display "--" as the indoor temperature on the main screen. Damper control module will operate in central mode (all dampers open). At the Lennox communicating thermostat, only zone 1 screen will be available. <p>NOTE: <i>The Lennox communicating thermostat will display the alert code as "Problem (Zoning Control)". Email notifications will describe the issue as " Zone "X" Temp Sensor Problem.</i></p>	Automatically clears 30 seconds after condition no longer exist.
543	Service Soon	ZS Zone 2 Temp Sensor Fault			
544	Service Soon	ZS Zone 3 Temp Sensor Fault			
545	Service Soon	ZS Zone 4 Temp Sensor Fault			
546		Service Soon	ZS Parameters resetting from restored power	<ul style="list-style-type: none"> An EEPROM is a memory device that stores and remembers the information even after power has been removed from the device. It saves settings that the user might have selected like to desired heating and cooling temperatures. When power is removed and then comes back on, the zone sensors (or thermostat for zone 1) remembers users setting. Code 546 is given if the zone sensor notices that the EEPROM has an issue right after power is first applied. The system will set itself to energy save mode and continue to operation 	Zone sensor will have to be replaced.
547		Service Soon	ZS Parameters resetting from system interruption	<ul style="list-style-type: none"> An EEPROM is a memory device that stores and remembers the information even after power has been removed from the device. It saves settings that the user might have selected like to desired heating and cooling temperatures. When power is removed and then comes back on, the zone sensor remembers the users setting. Code 547 is given if the zone sensor notices that the EEPROM has an issue sometime later after the product has been on for a while. It will not raise the issue until it needs to again read from the EEPROM memory when it is first powering to retrieve the necessary information. System will operate in a normal mode operator until power off. 	Zone sensor will have to be replaced.

Table 22. Lennox® S40 Smart Thermostat Alert Codes and Troubleshooting

E2A=Errors to Action, GF= Gas Furnace, AH=Air Handler, IU=Indoor unit (GF or AH), HP=Heat Pump, AC=Air Conditioner, OU=Outdoor Unit (AC or HP), PA=Pure Air S, ZA=Zone system, SRS=Smart Room Sensor, TS=Thermostat , IAQ- IAQ Monitor and WE=Wi-Fi Extender					
Alert Code	Inverter Flash Code	Priority Condition	Actual Displayed Alert Text Under dealer control center > Notifications	Component or System Operational State and Troubleshooting Tip	How to clear alert code
548		Service Soon	ZS Humidity Sensor Error	Without humidifiers or dehumidifiers, sensor reads out of range 0% to 100%. This message indicates humidity sensor has malfunctioned.	Zone sensor will have to be replaced or if sensor auto corrects itself the alert will be automatically cleared and system will return to normal operations.
551		Service Soon	ZS Zone Sensor Lost Communication	<p>Any lost communication between any zone sensor and the damper control module will result in applicable alert code(s) being displayed (543, 544 or 545) at the thermostat.</p> <ul style="list-style-type: none"> • A pop-up display on the thermostat will appear indicating a communication error. • Indoor temperature for the specific zone in error will displayed as "--" on the home screen. • When any zone sensor loses communication with the damper control module, the entire system will go into central mode (single temperature control). <p>Check for loose, damage or incorrect wiring between damper control module and the zone sensor reporting alert code 551.</p>	Once communication is reestablished the zone sensor will return to normal zone operations.
600		Information Only-Dealer	Load Shed Event	<p>Compressor has been cycled OFF on utility load shedding.</p> <ul style="list-style-type: none"> • Load shedding function provides a method for a local utility company to limit the maximum power level usage of the outdoor unit. • The feature is activated by applying 24VAC power across the L and C terminals on the outdoor control 	Automatically clears when L terminal is inactive.
601		Information Only-Dealer	OU Unit Low Ambient Operational Lockout	<ul style="list-style-type: none"> • Outdoor unit has been cycled off on low temperature protection. • Outdoor unit will not operate when the outdoor ambient is at or below 4°F (-15.6°C). • If the unit is satisfying a demand (running) and the outdoor ambient drops below 4°F (-15.6°C), the unit will continue to operate until the demand has been satisfied or the outdoor ambient drops to 15°F (-9.4°C) which will result in the unit being locked out (shut down). 	Automatically clears when low temperature condition no longer exists.
603		Service Soon / Service Urgent	AH Float Switch Sensed Open	<ul style="list-style-type: none"> • After being active for 10 minutes (600 seconds) the priority condition will change to Service Urgent. 	Automatically clears after fault recovered.
610		Service Urgent	Low Room Temperature Detected	<p>This alert will automatically notified the user that a low room temperature condition exist. A notification is displayed on the Thermostat and email notification sent to homeowner and dealer.</p> <p>The freeze alert protection parameter range is 30°F to 50°F (-1.11 to 10.0°C). Default is 40°F (4.44°C).</p> <p>NOTE: Notification is dependent on the thermostat having a active Wi-Fi connection and the user account has been setup and includes a valid email address.</p>	Automatically clears when condition is resolved.

Table 22. Lennox® S40 Smart Thermostat Alert Codes and Troubleshooting

E2A=Errors to Action, GF= Gas Furnace, AH=Air Handler, IU=Indoor unit (GF or AH), HP=Heat Pump, AC=Air Conditioner, OU=Outdoor Unit (AC or HP), PA=Pure Air S, ZA=Zone system, SRS=Smart Room Sensor, TS=Thermostat , IAQ- IAQ Monitor and WE=Wi-Fi Extender

Alert Code	Inverter Flash Code	Priority Condition	Actual Displayed Alert Text Under dealer control center > Notifications	Component or System Operational State and Troubleshooting Tip	How to clear alert code
611		Service Urgent	High Room Temperature Detected	<p>This alert will automatically notified the user that a high room temperature condition exist. A notification is displayed on the Thermostat and email notification sent to homeowner and dealer.</p> <p>The heat alert protection parameter range is 80°F to 100°F (26.67 to 37.78°C). Default is 90°F (32.22°C).</p> <p>NOTE: Notification is dependent on the thermostat having a active Wi-Fi connection and the user account has been setup and includes a valid email address.</p>	Automatically clears when condition is resolved.
700		Service Urgent	Thermostat Temp Sensor Problem	<p>The Thermostat's internal temperature sensor is not operating correctly. To resolve this issue, try the following:</p> <ul style="list-style-type: none"> Remove Thermostat from mag-mount and reattaching. Seal hole in wall behind mag-mount to minimize exposure to unconditioned air from inside the wall. Run "reset all" under dealer control center. If issue persist, then replace the Thermostat. 	Automatically clears when the system detects that the issue no longer exists.
701		Service Urgent	Thermostat Temp Above Limit	<p>The thermostat is reading indoor temperatures above the pre-programmed limit. The thermostat has a built-in non-adjustable high limit of 99°F.</p> <ul style="list-style-type: none"> Cool thermostat. Adjust set point. Run reset all under dealer control center. Replace Thermostat or mag-mount, if needed. 	Automatically clears when the system detects that the issue no longer exists.
703		Service Soon	Thermostat Humid Sensor Problem	Thermostat Humid Sensor Problem. Sensor is damaged or data is corrupted possibly.	First try a system reset, then if persists the thermostat would need replacement.
3000		Maintenance	Replace Filter 1	Replace filter.	Reset filter reminder for both
3001		Maintenance	Replace Filter 2	Replace filter.	
3002		Maintenance	Replace Humidifier Pad	Replace Humidifier Pad	Reset Humidifier pad reminder
3003		Maintenance	Replace UV Bulb	Replace UV Bulb	Reset UV Light reminder
3004		Maintenance	Maintenance Reminder	Not Applicable	Make service appointment with dealer and reset reminder
3005		Maintenance	PA Maintenance	Pure Air Maintenance	Make service appointment for Pure Air maintenance with dealer and reset reminder

Table 22. Lennox® S40 Smart Thermostat Alert Codes and Troubleshooting

E2A=Errors to Action, GF= Gas Furnace, AH=Air Handler, IU=Indoor unit (GF or AH), HP=Heat Pump, AC=Air Conditioner, OU=Outdoor Unit (AC or HP), PA=Pure Air S, ZA=Zone system, SRS=Smart Room Sensor, TS=Thermostat , IAQ- IAQ Monitor and WE=Wi-Fi Extender					
Alert Code	Inverter Flash Code	Priority Condition	Actual Displayed Alert Text Under dealer control center > Notifications	Component or System Operational State and Troubleshooting Tip	How to clear alert code
65537		Service Urgent	Missing Mag Mount Base	<ul style="list-style-type: none"> • Base not detected and alarm 65538 has been raised over 30 times. • Amber LED is displayed on thermostat. • Mount and wire mag-mount before powering up thermostat. 	Automatically clears once is detected for two seconds.
65538		Information Only - Dealer	Missing Mag Mount Base	<ul style="list-style-type: none"> • Base not detected for at least 30 seconds. • Amber LED is displayed on thermostat. • Mount and wire mag-mount before powering up thermostat. 	Automatically clears once is detected for two seconds.
65539		Service Urgent	Thermostat Lost Connection or Internal Fault	HD wall display not detected for more than 30 seconds.	Automatically clears once is detected for two seconds.
65540		Information Only-Dealer	Missing HD wall display	HD wall display not detected for less than 30 seconds..	Automatically clears once is detected for two seconds.
65541		Information Only-Dealer	Download Failed	Download for firmware failed.	Not applicable.
65542		Information Only-Dealer	Update Failed	Has verification failed. Update failed.	Not applicable. Automatically clears once is detected for two seconds.
65543		Information Only-Dealer	Firmware Updated	When new firmware has been successfully updated to the thermostat.	Clears automatically after successfully update.
65544		Information Only-Dealer	More Than 5 Tstats In A Group	<p>The system is limited to five (5) smart hubs per group. The system permits up to nine (9) individual groups. Each group can manage up to five (5) assigned smart hubs. If there are more than five (5) smart hubs detected in a single group, alert code 65544 will display. Alert code 65544 will NOT display if the number of smart hubs per group does NOT exceed five (5).</p> <p>EXAMPLE: <i>If two groups each have six (6) smart hubs assigned to it, 12 alert code notifications (alert code 65544) are communicated every minute until the system detects five (5) or less smart hubs per group.</i></p>	The alert code automatically clears after the system detects five (5) or less smart hubs in one group.
65545		Service Soon	Cooling Capacity Alert	<p>Cooling operation may not be sufficient for the hottest days. Based on local conditions and climatological data for zip code.</p> <p>EXAMPLE: <i>Dirty Filter, Low Refrigerant charge, TXV, etc. Symptom during mild temperatures may include; system running longer than normal but not showing any other symptoms.</i></p>	Auto cleared on next prediction

Table 22. Lennox® S40 Smart Thermostat Alert Codes and Troubleshooting

E2A=Errors to Action, GF= Gas Furnace, AH=Air Handler, IU=Indoor unit (GF or AH), HP=Heat Pump, AC=Air Conditioner, OU=Outdoor Unit (AC or HP), PA=Pure Air S, ZA=Zone system, SRS=Smart Room Sensor, TS=Thermostat , IAQ- IAQ Monitor and WE=Wi-Fi Extender					
Alert Code	Inverter Flash Code	Priority Condition	Actual Displayed Alert Text Under dealer control center > Notifications	Component or System Operational State and Troubleshooting Tip	How to clear alert code
70001		Service Soon	IAQ: Internal Sensor Fault	<p>This issue will occur when:</p> <ul style="list-style-type: none"> Any of the CO₂, VOC and PM sensors output experiences an internal communication outage. Collected data values are out of range. <p>Cycle device power may clear condition. To cycle power, press the device pairing button for one second.</p> <p>If cycling power does not resolve issue then:</p> <ul style="list-style-type: none"> Remove device from the BLE network. Perform a factory reset of the device. Attempt to add device back to BLE network. 	<ul style="list-style-type: none"> If cycling power or factory reset does not resolve issue then replace the device. Automatically clears when the system detects that the issue no longer exists.
70002		Service Soon	IAQ: Internal Data Fault	<p>Unable to access internal data. Cycle device power may clear condition. To cycle power, press the pairing button for one second.</p> <p>If cycling power does not resolve issue then:</p> <ul style="list-style-type: none"> Remove device from the BLE network. Perform a factory reset of the device. Attempt to add device back to BLE network. 	<ul style="list-style-type: none"> If recycling power or factory reset does not resolve issue then replace device. Automatically clears when the system detects that the issue no longer exists.
70003		Service Urgent	IAQ Side Switch in OFF position	Slide the side switch to the ON position. ON is the up position.	<ul style="list-style-type: none"> Set side switch to ON position will clear this alert code. Automatically clears when the system detects that the issue no longer exists.
70004		Service Soon	IAQ: Replace Smart IAQ Monitor	<ul style="list-style-type: none"> The five year service life of the device is about to expire. Device will continue to function however sensor data collected may become unreliable thus affecting air quality in the home. 	<ul style="list-style-type: none"> Remove device from thermostat BLE network and replace device. Automatically clears when the system detects that the issue no longer exists.
70501		Service Soon	Custom Sensor Name: Internal Data Fault	<p>Not able to collect samples communication fault) or measured value is out of range from any of the sensor (TRH Sensor or Thermistor) or occupancy sensor voltage < 0.2V or > 2.5V, then condition is triggered.</p> <ul style="list-style-type: none"> Power cycle Smart Room Sensor Wait for 10 minutes for self-clearing to take place, if condition is resolve for temperature and relative humidity. 	For occupancy sensor self-clearing will take 45 minutes (3 x 15 minute internals)
70502		Service Soon	Sensor: {Custom Sensor Name}: Internal Fault	Unable to access internal data. Cycle power. If cycling power does not resolve issue, replace Smart Room Sensor.	Automatically clears when the system detects that the issue no longer exists.
70503		Maintenance	Sensor: {Custom Sensor Name}: Low Battery - Change Batteries Soon	Battery life is less than 3%. Replace with two Lithium Ion AA batteries to resolve issue.	Automatically clears when the system detects that the issue no longer exists.

Table 22. Lennox® S40 Smart Thermostat Alert Codes and Troubleshooting

E2A=Errors to Action, GF= Gas Furnace, AH=Air Handler, IU=Indoor unit (GF or AH), HP=Heat Pump, AC=Air Conditioner, OU=Outdoor Unit (AC or HP), PA=Pure Air S, ZA=Zone system, SRS=Smart Room Sensor, TS=Thermostat , IAQ- IAQ Monitor and WE=Wi-Fi Extender					
Alert Code	Inverter Flash Code	Priority Condition	Actual Displayed Alert Text Under dealer control center > Notifications	Component or System Operational State and Troubleshooting Tip	How to clear alert code
70504		Maintenance	Sensor: {Custom Sensor Name}: 1% Battery - Change Batteries	Battery percent is less than 1%. Replace with two Lithium Ion AA batteries to resolve issue.	Automatically clears when the system detects that the issue no longer exists.
71001		Service Soon	WE: Internal Data Fault	<ul style="list-style-type: none"> Unable to access internal data. Upon power cycle condition may clear itself. If recycling power does not resolve issue, replace Extender. 	Upon power cycle condition may clear itself.
71504		Information Only-Dealer	OU: Suction Temperature Sensor: incorrect reading	<ul style="list-style-type: none"> Measured suction temperature (ST) is not within the expected range. No major impact to the system Check and replace sensor if it is failed. 	Automatically clears when the system detects that the issue no longer exists.
71505		Information Only-Dealer	OU: Liquid Temperature Sensor: incorrect reading	<ul style="list-style-type: none"> Measured liquid temperature (LT) is not within the expected range. No major impact to the system Check and replace sensor if it is failed. 	Automatically clears when the system detects that the issue no longer exists.
71506		Information Only-Dealer	OU: Suction Pressure Sensor: Incorrect Reading	<ul style="list-style-type: none"> Measured suction pressure (SP) is not within the expected range. No major impact to the system Check and replace sensor if it is failed. 	Automatically clears when the system detects that the issue no longer exists.
71507		Information Only-Dealer	OU: Liquid Pressure Sensor: Incorrect Reading	<ul style="list-style-type: none"> Measured liquid pressure (LP) is not within the expected range. No major impact to the system Check and replace sensor if it is failed. 	Automatically clears when the system detects that the issue no longer exists.
71508		Information Only-Dealer	OU: Outdoor Temperature Sensor: Incorrect Reading	<ul style="list-style-type: none"> If measured outdoor temperature (ODT) is not within the expected range. No major impact to the system Check and replace sensor if it is failed. 	Automatically clears when the system detects that the issue no longer exists.
71509		Information Only-Dealer	HP: Outdoor Coil Temperature Sensor: Incorrect Reading	<ul style="list-style-type: none"> If measured outdoor coil temperature (ODTCoil T) is not within the expected range. No major impact to the system Check and replace sensor if it is failed. 	Automatically clears when the system detects that the issue no longer exists.
71510		Service Soon	OU: ID TXV Failure	<ul style="list-style-type: none"> Super Heat average is not in expected range. (Too high or too low superheat) Replace Expansion Valve. 	Automatically clears when the system detects that the issue no longer exists.
71511		Service Soon	IU: Duct or Filter Blockage	Clean ducts or replace filter.	Automatically clears when the system detects that the issue no longer exists.
71512		Service Urgent	OU: High-Pressure Switch Fault	<ul style="list-style-type: none"> If switch tripped without meeting the liquid pressure condition. If Liquid pressure > 500 psig then replace high-pressure switch. 	Automatically clears when the system detects that the issue no longer exists.

Table 22. Lennox® S40 Smart Thermostat Alert Codes and Troubleshooting

E2A=Errors to Action, GF= Gas Furnace, AH=Air Handler, IU=Indoor unit (GF or AH), HP=Heat Pump, AC=Air Conditioner, OU=Outdoor Unit (AC or HP), PA=Pure Air S, ZA=Zone system, SRS=Smart Room Sensor, TS=Thermostat , IAQ- IAQ Monitor and WE=Wi-Fi Extender

Alert Code	Inverter Flash Code	Priority Condition	Actual Displayed Alert Text Under dealer control center > Notifications	Component or System Operational State and Troubleshooting Tip	How to clear alert code
71513		Service Soon	OU: Low-Pressure Switch Fault	<ul style="list-style-type: none"> If switch tripped without meeting the suction pressure condition. Replace low-pressure switch. 	Automatically clears when the system detects that the issue no longer exists.
71514		Service Soon	OU: System Low on Refrigerant Charge	<ul style="list-style-type: none"> If sub cooling average is not within expected range for given ODT and compressor Hz. Add refrigerant 	Automatically clears when the system detects that the issue no longer exists.
71515		Service Urgent	HP: Reversing Valve Stuck	<ul style="list-style-type: none"> If liquid and suction pressure average ratio does not fall within the expected range. Service reversing valve message. 	Automatically clears when the system detects that the issue no longer exists.
71516		Service Urgent	OU: Outdoor Fan Motor Failure	<ul style="list-style-type: none"> If superheat suction pressure values are not within expected range. Service outdoor fan. 	Automatically clears when the system detects that the issue no longer exists.
71517		Service Urgent	IU: Indoor Fan Motor Failure	<ul style="list-style-type: none"> If superheat suction pressure values are not within expected range. Service indoor fan. 	Automatically clears when the system detects that the issue no longer exists.
71518		Service Urgent	OU: Compressor Failed to Start	<ul style="list-style-type: none"> If liquid and suction pressure average ratio does not fall within the expected range. Service compressor. 	Automatically clears when the system detects that the issue no longer exists.
71519		Service Urgent	HP: Incorrect Reversing Valve Mode	<ul style="list-style-type: none"> If Outdoor coil temperature plus 3°F is less than outdoor temperature or if ODT plus 3°F is greater than ODT Coil temperature along with Reverse valve status open/closed. Check solenoid wiring for reverse valve. 	Automatically clears when the system detects that the issue no longer exists.
71520		Service Urgent	OU: Blocked Liquid Line	<ul style="list-style-type: none"> If superheat suction pressure values are not within expected range. Check liquid line, expansion and service valves. 	Automatically clears when the system detects that the issue no longer exists.
71521		Service Urgent	HP: Outdoor TXV Failure	<ul style="list-style-type: none"> Superheat average is not in expected range. Replace Outdoor Expansion Valve. 	Automatically clears when the system detects that the issue no longer exists.
80001		Information only Dealer	IAQ: Persistent Poor Air Quality	<p>Cycle power to device.</p> <p>If cycling power does not resolve the issue, check all installed Indoor Air Quality (IAQ) equipment installed in the HVAC system. For example check:</p> <ul style="list-style-type: none"> All installed IAQ equipment are power on, connected and working properly. HC air filters and replace if dirty. Pure Air or Pure Air S UV lamp and if not working replace. Check filter and replace if dirty. ERV/HRV filter and replace if dirty. UV Germicidal lamp is working and replace if necessary. 	<ul style="list-style-type: none"> If cycling power and checking all installed IAQ equipment does not resolve the issue, then replace device. Automatically clears when the system detects that the issue no longer exists.

Table 22. Lennox® S40 Smart Thermostat Alert Codes and Troubleshooting

E2A=Errors to Action, GF= Gas Furnace, AH=Air Handler, IU=Indoor unit (GF or AH), HP=Heat Pump, AC=Air Conditioner, OU=Outdoor Unit (AC or HP), PA=Pure Air S, ZA=Zone system, SRS=Smart Room Sensor, TS=Thermostat , IAQ- IAQ Monitor and WE=Wi-Fi Extender

Alert Code	Inverter Flash Code	Priority Condition	Actual Displayed Alert Text Under dealer control center > Notifications	Component or System Operational State and Troubleshooting Tip	How to clear alert code
80002		Information only Lennox	XX: Unresponsive Wireless Device Fault	<p>Wireless BLE device is connected to the network but has failed to respond to commands. Try cycling power to device.</p> <p>If cycling power does not resolve issue then:</p> <ul style="list-style-type: none"> Remove device from the BLE network. Perform a factory reset of the device. Attempt to add device back to BLE network. 	<ul style="list-style-type: none"> If recycling power or factory reset does not resolve issue then replace device. Automatically clears when the system detects that the issue no longer exists.
80003		Service Soon	Lost communication with wireless Device	<p>Try cycling power to the device.</p> <p>If cycling power does not resolve issue then:</p> <ul style="list-style-type: none"> Remove device from the BLE network. Perform a factory reset of the device. Attempt to add device back to BLE network. 	<ul style="list-style-type: none"> If recycling power or factory reset does not resolve issue then replace device. Automatically clears when the system detects that the issue no longer exists.
80005		Service Soon	XX: Unknown Wireless Device Found.	<ul style="list-style-type: none"> Upon power cycle condition may clear itself. Move the wireless BLE device closer to the thermostat or add a Lennox Wireless Extender to increase the wireless coverage area. 	Automatically clears when the system detects that the issue no longer exists.
--		Service Soon	--	<p>Possible loose or mis-wired connections or two zone sensors are assigned the same zone number. Two dashes will be displayed on the S40 thermostat for indoor temperature and/ or zone sensor. The system will go into central mode. Individual zone functions is disabled. Anytime the zone sensor loses communication with the damper control module, the entire system will go into central mode. If two sensors are assigned the same zone number, this could result in the double dashes to appear as well.</p>	<ul style="list-style-type: none"> If two zone sensors are assigned the same zone number, this could cause the double dashes to appear. If loose or mis-wired connection was confirmed, correct the issue and run the re-configuration procedure.

Installation Checklist

Thermostat Checks:		YES	NO
1	Is the thermostat properly mounted to either a wall stud or wall? (Do not mount on equipment or ductwork)		
2	Is communication status LED (green) visible? When LED is active it indicates that 24VAC is present at the thermostat. It also indicates communication is active between thermostat and Thermostat.		
3	Are all terminal wiring properly connected and tight?		
4	When required, is either or both the discharge (DATS) and outdoor air temperature (OATS) sensors properly connected and isolated when used?		
Thermostat Checks:		YES	NO
1	Is the Thermostat properly placed and connected to wall plate?		
2	Are all terminal wiring properly connected and tight on wall plate?		
3	Is the screen blank after initial power-up? The Thermostat may take up to three minutes before anything appears on the screen due to a Thermostat low battery condition. Thermostat battery charging only occurs when connected to the sub-base.		
System Checks:		YES	NO
1	Is the Wi-Fi connected?		
2	Has the homeowner downloaded the Lennox Home application from either Google Play or IOS App Store to their mobile devices?		
3	Is the Lennox Dealer account number or your main shop phone number been added to the dealer information screen?		
4	If applicable, has the air handler's electric heat strips been commissioned? If not, commissioning of heat strips must be performed.		
5	Has a complete system test been run? If not, from the Thermostat home screen go to Settings > Advance Settings > View Support Service Control Center > and select Tests.		

Technical Support and Mobile App for Installers/ Technicians Only

Technical Support for Installers/Technicians Only

Lennox Residential technical support can be reached at 1-800-453-6669. Hours for support are Monday through Friday 8am - 8pm EST.

Tell us the issue so we can connect you to the right rep, offer relevant tips, reminders, and follow-up! Get targeted help with:

- Complaints
- Technical support
- Repairs
- Returns

Lennox Smart Technician App for Installers/Technicians Only

The *Lennox Smart Technician App* enables HVAC technicians to set up, configure, and test a Lennox S40 system directly on their mobile device.

Once installed, technicians can pair their mobile device to the Lennox Smart Thermostat and make adjustments from anywhere inside the home. Technicians are able to configure and/or run diagnostics from their smart device instead of being tethered to the thermostat.

With just a touch, technicians can:

- Setup and configure the system
- Adjust parameters
- Run system tests

This app is designed for Lennox HVAC technicians servicing Lennox® S40 Smart Thermostat systems.

LennoxPros Mobile Application for Installers/Technicians Only

LennoxPROs.com and the LennoxPROs mobile application have all the information HVAC Professionals and businesses need in one place. From shopping for parts and supplies to using our FREE e-tools, we have you covered.

LennoxPros Service Dashboard

The Service Dashboard displays Lennox® thermostat installations in one convenient location. The Service Dashboard is accessible via www.LennoxPros.com.

The thermostat is accessible via the Service Dashboard only if the dealership's main phone number or company name is added during thermostat commissioning and the homeowner has granted Monitoring and/or Advanced Diagnostic access.

Service Dashboard Search Screen

- Customers can be located using the following criteria: homeowner name, email, address, or serial number.
- Search results can be filtered by: thermostat type, alert type, access level or maintenance reminders.

Customer Search Results

Displays a list of customers with installed Lennox® thermostats and their locations:

- Name
- Address
- Phone
- Email
- Thermostat Type and Monitor Status

Map displays the following:

- Shows all customer's locations and any current alerts
- Color-coded pins on the map denote the following:
 - » Red - Service Urgent
 - » Yellow - Service Soon
 - » Green - No Alerts, normal operation
 - » Black - Not sharing system information

NOTE: Click on a customer's pin to view information about their system.

NOTE: Selecting a customer from the list or map pin will display the following:

- » Home System(s)
- » Owner Information
- » Remote In
- » Alerts & Reminders
- » Equipment & Reports

Home Systems

- Shows thermostat connection status
- Multiple home systems are displayed for each customer if there are more than one system

System History

This section provides a list of alerts over the past 12 months

Temporary Advanced Diagnostics Access (Remote In Button)

- Allows the dealer remote access to the customer's thermostat (if enabled)
- Remote In Thermostat Controls share the same appearance and function as the thermostat's touchscreen display. This feature allows dealers to adjust the customer's thermostat settings remotely.
- **Remote In** button is red if temporary remote access is granted by homeowner. The **Remote In** button is gray if the homeowner has not granted temporary remote access. If the homeowner has not granted, the **Send Request** button is available to the technician.
- **Send Request** button allows the technician to request remote access to the customer's thermostat. The availability of this button indicates the homeowner prefers to grant access to their thermostat on a temporary basis only.

To request temporary access to the customer's thermostat:

1. Select the **Send Request** button.

A request is sent to the customer asking for remote access to their thermostat. Access is permissible for 24 hours.

2. Press the **Remote In** button to gain temporary access to the customer's thermostat after access is granted.

NOTE: After the 24-hour window expires, access to the homeowner's system is automatically terminated. Technicians can press **Cancel Session** to terminate the access prior to the 24-hour deadline.

3. End the temporary access by pressing **Cancel Session** after diagnostics and troubleshooting are complete

This ends remote access to the homeowner's thermostat.

Alerts & Reminders: [System Name]

Tabs for Alerts - Service Urgent, Service Soon, Cleared and Reminders

NOTE: Clicking on a card with an alert expands to display the Remote In control (if enabled by the homeowner) and Troubleshoot (access to the Lennox Troubleshooting Center which includes error code lookups and any available documentation).

Equipment & Reports

- Equipment Tab
 - » A detailed list of all installed equipment for a particular system
 - » Menus are available for each Equipment Type for Technical Documents, Warranty Lookup, and Repair Parts.
- Reports Tab
 - » View Performance Reports, Installation Reports, and Installation Update Reports
 - » Generate Monthly Performance Reports
 - » Generate Installation Update reports
 - » View Performance Reports link displays a graphical view of the system performance
 - » Generating any report will save it as a PDF file to send to the customer or for record keeping.

NOTE: For additional information please visit the Service Tools Help Center and click on Service Dashboard.

Equipment Configuration Profile (ECP)

The Equipment Configuration Profile (ECP) is designed to assist technicians achieve higher quality and faster installations. This feature also enables dealers to create unique equipment profiles specific to products sold at their dealership. From the comfort of a desktop computer or mobile phone, dealers can customize profiles (via the Service Dashboard on LennoxPros) that will factor in the local weather conditions for all communicating and non-communicating, one-stage, two-stage and variable speed air conditioners, heat pumps, furnaces, and air handlers.

CREATE A NEW EQUIPMENT PROFILE

1. Select **Equipment Profile** from the Service Dashboard menu bar.

The Equipment Profiles screen displays two tabs: *Custom Profiles* and *Default Profiles*.

2. Select the *Custom Profiles* tab (to build a completely new profile) or the *Default Properties* tab (to build a profile using a Lennox default profile) and click **Create New Profile**.

The *Select Equipment* screen displays.

3. Locate a default profile from which to build a customized profile.

NOTE: *There is a default profile for each unit type and dealers are able to make adjustments to the default settings, if necessary.*

4. Click **Select Equipment**.

The *Set Values* screen displays.

5. Adjust the set values (if necessary) and click **Save**.

The *Profile Details* screen displays.

6. Complete the fields on the *Profile Details* screen.

NOTE: *Click **Back** to return to the Set Values screen if changes are necessary. Entries in the Profile Details fields will be lost.*

7. Click **Save**.

The *Confirm Profile Creation* screen displays.

8. Verify the entries are correct and click **Confirm**.

The Success dialog displays. This dialog confirms the new Equipment Profile has been saved and technicians can import the profile during configuration.

9. Click **Return to Dashboard** to return to the *Custom Profiles* screen or **Create New Profile** to build another custom Equipment Profile.

NOTE: *Dealers can delete a custom Equipment Profile by clicking the **Delete Profile** link associated with the profile to be deleted.*

DELETING A CUSTOM PROFILE

If a custom profile is no longer valid or there is simply no need to maintain a custom profile, dealers can choose to delete it.

NOTE: *Default profiles can not be deleted.*

1. Click **Equipment Settings** from the Service Dashboard menu.
2. Select the **Custom Profiles** tab.
3. Locate the profile to delete.
4. Click **Delete Profile**.

A *Delete Profile* dialog displays confirming the command to delete the profile.

5. Click **Yes, Delete**.

The profile is removed from the Custom Profiles list.

Equipment Profiles

Equipment profiles automatically download to the Smart Tech App after the technician logs in. The technician can then create a new list (or job) by using their mobile device to scan the equipment's serial number. Alternatively, technicians can manually enter the serial number into the app. After the system identifies the serial number, equipment profiles (that match the equipment type) display.

Technicians can choose the desired equipment profile, which automatically configures the equipment to the settings created by the dealer. If the equipment profile has not been set up, a default factory setting profile is available.

NOTE: *This feature is currently only available for installations with the Lennox® S40 Smart Thermostat, but can support both communicating and non-communicating Air Conditioners, Furnaces, and Heat Pumps. After installation and configuration are complete, the technician can run an installation report for the homeowner to confirm a successful installation.*

After the technician logs in, the *Welcome to the Lennox Smart Tech App* screen displays. There are three options from which to choose:

- » **Capture Equipment** - enables technicians to scan or manually enter equipment barcode.
- » **Connect to a Thermostat** - enables the technician to connect via the Smart Tech App to the homeowner's thermostat.
- » **View Captured Equipment** - allows the technician to view equipment lists previously captured by the technician.

Unregistering the S40 Smart Thermostat

The S40 Smart Thermostat is linked to a home profile in the homeowner's account. Any action that impacts the home profile will impact all thermostats associated with that home profile.

The following actions will unregister the S40 Smart Thermostat.

Unregister System

(S40 Smart Thermostat & Lennox Home App)

Navigate to: **Menu > Settings > Advanced Settings > Unregister System**

Table 23. Unregister Thermostat

Parameter	Description
Account	Not affected by unregistering the thermostat
Home	Home profile is not affected by unregistering the thermostat
Target Thermostat	Unregisters the thermostat. Zoning, Air Flow, and Ventilation settings are not affected.
Additional Thermostats	Additional thermostats are not affected. Zoning, Air Flow, and Ventilation settings are not affected.

Move Out

(S40 Smart Thermostat)

Navigate to: **Menu > User Account > Move Out**

Table 24. Move Out

Parameter	Description
Account	Not affected by moving out
Home	Home profile is deleted
Target Thermostat	Unregisters the thermostat. Zoning, Air Flow, and Ventilation settings are not affected.
Additional Thermostats	Unregisters additional thermostats in the home. Zoning, Air Flow, and Ventilation settings are not affected.

Remove Home

(Lennox Home App)

Navigate to: **Menu > User Account > Home Info > Remove Home**

Table 25. Remove Home

Parameter	Description
Account	Not affected by removing home
Home	Home profile is deleted
Target Thermostat	Unregisters the thermostat. Zoning, Air Flow, and Ventilation settings are not affected.
Additional Thermostats	Unregisters additional thermostats in the home. Zoning, Air Flow, and Ventilation settings are not affected.

Delete Account

(Lennox Home App)

Navigate to: **Menu > User Account > Account > Delete Account**

Table 26. Delete Account

Parameter	Description
Account	Account is deleted
Home	Home profile is deleted
Target Thermostat	Unregisters the thermostat. Zoning, Air Flow, and Ventilation settings are not affected.
Additional Thermostats	Unregisters additional thermostats associated with account. Zoning, Air Flow, and Ventilation settings are not affected.

Factory Reset

(S40 Smart Thermostat)

Navigate to: **Menu > Settings > Advanced Settings > View Support Service Control Center > Equipment Settings > Reset > Factory Reset Thermostat**

Table 27. Factory Reset

Parameter	Description
Account	Not affected by factory reset
Home	Home profile is not affected by factory reset
Target Thermostat	Unregisters the thermostat. Zoning, Air Flow, and Ventilation settings are reset.
Additional Thermostats	Additional thermostats are not affected. Zoning, Air Flow, and Ventilation settings are not affected.

Index

A

- Advanced Dehumidification Descriptions** 49
- Airflow Profile - Cooling** 41, 42
- Alert Codes and Troubleshooting** 55
- Auto Brightness** 31
- Auto Changeover**
 - Humidif. Deadband* 31
 - Temp Deadband* 31
- Auto Dehumidification Overcooling Threshold** 31
- Automatic Max Defrost** 43
- Aux Heating Activation Threshold** 31

B

- Balance Point Control** 31
- Brightness Value** 31

C

- Commissioning**
 - Using the Mobile Setup App* 18
- Compressor Shift Delay ON / OFF** 44, 45
- Compressor Short Cycle Delay** 44, 45
- Continuous Indoor Blower Airflow** 41, 42
- Cooling Indoor Blower**
 - Off Delay* 41, 42
 - On Delay* 41, 42
- Cooling Mode** 32
- Cooling Prognostics** 32

D

- Defrost Termination Temp** 44
- Dehumidification**
 - Airflow %* 42
 - Airflow Adjustment Adder* 44, 45
 - Set Point* 49
 - Setting Options* 49
- Dew Point Adjustment** 32
- Diagnostics** 48
- Discharge Air Sensor (DATS)**
 - Integral Gain* 32
 - Offset* 32
 - Proportional Gain* 32
- Display**
 - Air Quality* 32
 - Indoor Humidity* 32
 - Outdoor Weather* 32

E

- Electrical Noise** 8
- Electric Heat**
 - Airflow* 41
 - Control Mode* 32
 - Stages During Defrost* 32
- Energy Recovery Ventilator (ERV)** 51
- Equipment Configuration Profile** 108
- Equipment Name**
 - Air Conditioner* 45
 - Air Handler* 41
 - Furnace* 42
 - Heat Pump* 45
 - Smart Hub* 32
 - Zoning Control* 46
- Equipment Profiles** 108

- EvenHeat Discharge Temp** 32

F

- Factory Reset**
 - Smart Hub* 47
 - Thermostat* 47
- Fan Cycling** 45
- Freezing Alert Temperature** 35
- Fresh Air Dampers** 50

G

- Gas Heat Control Mode (SLP98 only)** 33
- Gas Heating Activation Temp Difference** 33
- Group ID** 33

H

- Heat / Cool Stages Locked In** 33, 40
- Heating Airflow Control Type** 43
- Heating Indoor Blower**
 - Off Delay* 41, 42
 - On Delay* 41, 43
- Heat Recovery Ventilator (HRV)** 51
- High**
 - Balance Point* 31
 - Cooling Airflow* 41, 43
 - Heating Airflow* 43
 - HP Airflow* 41, 43
 - Normal Cooling Airflow* 45
 - Normal HP Heating Airflow* 45
- HP**
 - Blower On Delay* 43
 - Heating Lockout Time* 33
 - Heating Mode* 33

- Indoor Blower Off Delay* 41, 43
- Indoor Blower On Delay* 42

- Humiditrol Comfort Adjust** 33
- Humidity Reading Calibration** 33

I

- Information** 47
- Installation**
 - Checklist* 105
 - Recommendations* 16
 - Report* 48

L

- Lennox Smart Zoning** 50
- Lock In 2nd Stage HP by Outdoor Temp** 33

Low

- Balance Point* 31
- Cooling Airflow* 42, 43
- Heating Airflow* 43
- HP Airflow* 42
- Normal Cooling Airflow* 45
- Normal HP Heating Airflow* 45

M

Max

- Defrost by Weather* 45
- Heat Setpoint* 33
- Humidification Setpoint* 33

Min

- Cool Setpoint* 34
- Dehumidification Setpoint* 34

Mobile Applications

 106

Modulating

- Cooling Cycles Per Hour* 34
- Cooling Steady State PI Gain* 34
- Cooling Step Change PI Gain* 34

Gas Heating Cycles Per Hour (SLP98V only) 34
Gas Heating Steady State PI Gain (SLP98V only) 34
Gas Heating Step Change PI Gain (SLP98V only) 34
HP Heating Cycles Per Hour 34
HP Heating Steady State PI Gain 34
HP Heating Step Change PI Gain 34

Multiple Thermostats 20

N

Number of Gas Heating Stages 34

O

Outdoor Temperature

Calibration 34
Reading Calibration 31
Source 34

Overcooling 49

P

Perfect Temp 35

Proximity Control 35

PureAir S 50

PureAir Wiring Diagram 16

R

Received Signal Strength Indication (RSSI) 29

Re-configure System 47

Reset

Air Conditioner 45
Air Handler 42
Furnace 43
Heat Pump 45
HVAC Equipment 47
Smart Hub 35
Zoning Control 46

S

S40 and S30 Thermostats 28

Screen Locked 35

Screen Saver 35

Smart Alert Enable 35

Smart Devices

Smart Air Quality Monitor 47
Smart Devices Network 46
Smart Room Sensor 47
Wireless Extender 47

Smart Hub

Group ID 33
Installation 4
Multiple Devices 20, 33
Parameters 30
Restart 20, 47

Smooth Setback Recovery (SSR) 36

Soft Disable 55

Stage

Delay Timers 36
Differentials 36

T

Temperature Control Mode 36, 38

Temp Reading Calibration 36

Terminal Designations 8

Tests 48

U

Unregistering the S40 Smart Thermostat 109

V

Ventilation

Control Mode 52
Control Mode Parameters 37

W

Wall Insulation 38

Wide Setpoint 38

Wi-Fi

Access Point Hidden 29
Signal Strength Indicator 29

Wi-Fi Considerations 28

Wi-Fi Network Types Supported 28

Z

Zone 1 through 4

Continuous Blower CFM 39
Cooling CFM 39
Heating CFM 39
Temp Reading Calibration 46

Zoning

Anticipated Discharge Air Temperature Adjustment 39
Continuous Blower CFM 39
Gas Heating DAT Cool Down Target 39
Minimum Zone Run-Time 39
Supply Air Temp Limit for Cooling 39
Supply Air Temp Limit for Gas / Electric Heating 39
Target Supply Air Temp for Cooling 39
Target Supply Air Temp for HP Heating 39

Zoning Target Supply Air Temp for Gas/Electric Heating 39