

# LGM

## MODEL L™ ROOFTOP UNITS

Ultra-High Efficiency | Lennox® CORE Controller | Environ™ Coil | **R-454B** | 60Hz



COMMERCIAL  
PRODUCT SPECIFICATIONS (EHB)

7.5 to 12.5 Tons

Net Cooling Capacity – 88,000 to 136,000 Btuh  
Gas Input Heat Capacity – 85,000 to 240,000 Btuh

# MODEL / L



SMART WIRE™ SYSTEM



### MODEL NUMBER IDENTIFICATION

**LGM120U5EM3Y**

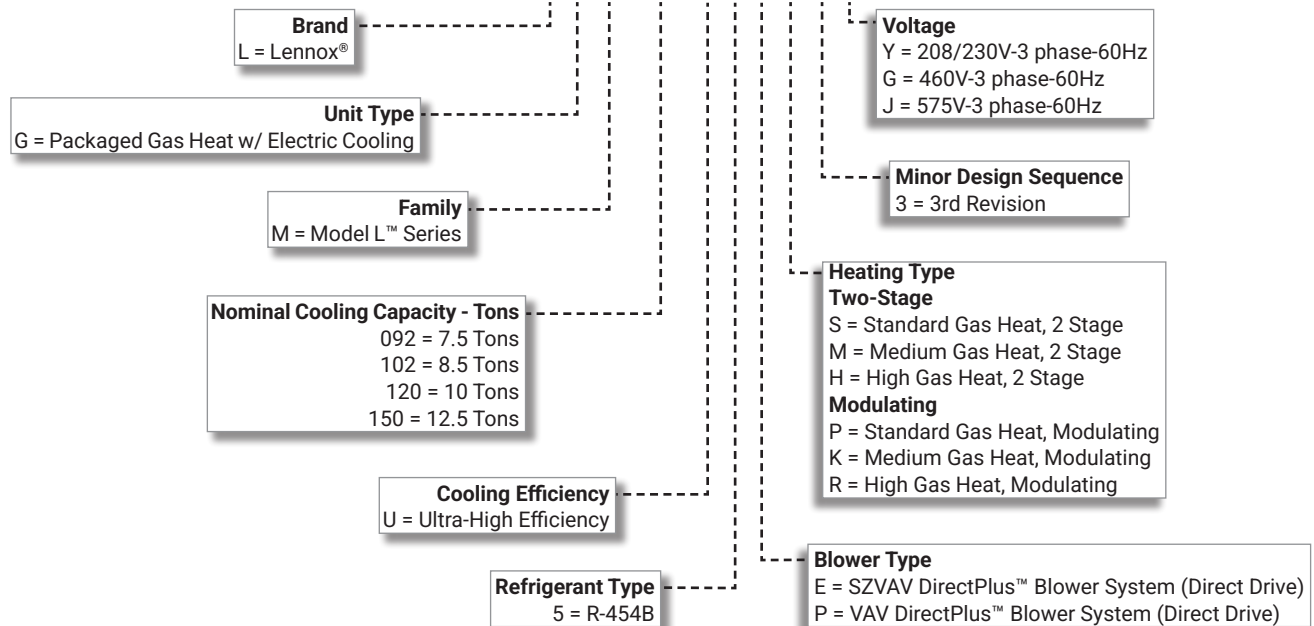

## FEATURE HIGHLIGHTS

The Model L™ packaged rooftop line is engineered with advanced variable speed technology to offer some of the highest energy efficiencies in the industry while delivering superior temperature and humidity control in a wide variety of commercial applications.

1. Heat Exchanger/Inshot Burners
2. Variable Capacity Scroll Compressor and Fixed Capacity Scroll Compressor
3. Environ™ Coil System
4. Variable-Speed ECM Outdoor Coil Fan Motors
5. Heavy Gauge Steel Cabinet
6. Hinged Access Panels
7. DirectPlus™ Direct Drive ECM Blower System
8. Air Filters
9. Lennox® CORE Control System
10. Humiditrol®+ Dehumidification System (option)

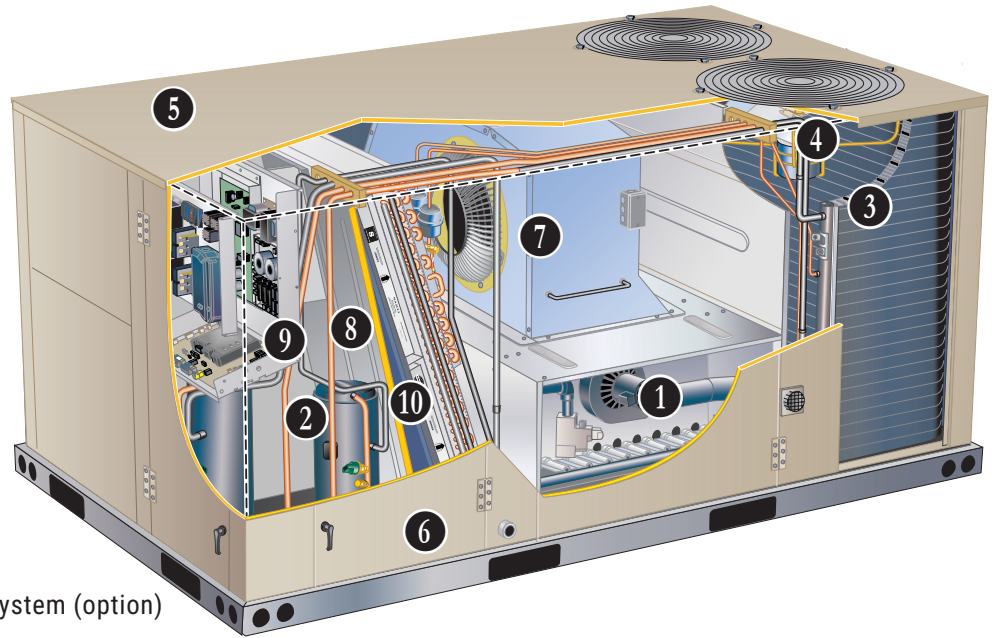

## CONTENTS

Approvals And Warranty . . . . .	3
Blower Data . . . . .	27
Control System . . . . .	9
Cooling Ratings . . . . .	24
Dimensions . . . . .	34
- Accessories . . . . .	35
- Unit . . . . .	34
Electrical Data . . . . .	30
- 7.5 Ton . . . . .	30
- 8.5 Ton . . . . .	30
- 10 Ton . . . . .	31
- 12.5 Ton . . . . .	31
Features And Benefits . . . . .	4
High Altitude Derate . . . . .	23
Humiditrol®+ Dehumidification System Option. . . . .	13
Humiditrol® Dehumidification System Ratings. . . . .	26
Model Number Identification. . . . .	1
Optional Conventional Temperature Control Systems. . . . .	14
Options / Accessories . . . . .	19
Outdoor Sound Data . . . . .	32
Sequence Of Operation. . . . .	16
Specifications . . . . .	22
- Gas Heat . . . . .	23
- Unit . . . . .	22
Unit Clearances . . . . .	32
Weight Data . . . . .	33
- Unit . . . . .	33

## APPROVALS AND WARRANTY

### APPROVALS

- All models are AHRI Standard 340/360-2023 certified
- ENERGY STAR® certified
- ETL and CSA listed
- All models are ASHRAE 90.1-2025 compliant
- All models meet DOE 2023 energy efficiency standards
- All models are listed to UL 60335-1 and UL 60335-2-40 and meet the Refrigerant Detection and Dissipation Requirements
- Components are bonded for grounding to meet safety standards for servicing required by ETL, NEC and CEC
- All models meet California Code of Regulations, Title 24 and ASHRAE 90.1-2025 Section 6.4.3.10 requirements for staged airflow
- All models have been sound tested in accordance with test conditions included in AHRI Standard 270 or 370
- ISO 9001 Registered Manufacturing Quality System
- All models have HCAI (formerly OSHPD) OSP and Special Seismic Certification (Number: [OSP-0596](#)), and meet 2021 International Building Code (IBC), 2022 California Building Code (CBC) ASCE 7, and ICC-ES AC156
- All models have FSA approval and are compliant with standard ASCE 7-22 (ASD) and the Florida Building Code Eighth Edition (2023)
- Units are charged with virgin refrigerant to comply with NYCRR Part 494
- All models are fully charged and run tested to verify unit operation and functionality

### WARRANTY

- Aluminized Steel Heat Exchanger - Limited ten years
- Stainless Steel Heat Exchanger (optional) - Limited fifteen years
- Compressor - Limited five years
- Environ™ Coil System - Limited three years
- Lennox® CORE Unit Controller - Limited three years
- High Performance Economizers (optional) - Limited five years
- All other covered components - Limited one year

## FEATURES AND BENEFITS

### HEATING SYSTEM

- 1 • Aluminized steel inshot burners
- Direct spark ignition
- Electronic flame sensor
- Combustion air inducer
- Redundant automatic gas valve with manual shut-off

#### Heat Exchanger

- Tubular construction, aluminized steel
- Life-cycle tested

**NOTE** - Optional Stainless Steel Heat Exchanger is required if mixed air temperature is below 45°F.

#### Electronic Pilot Ignition

- Electronic spark igniter provides positive direct ignition of burners on each operating cycle
- Permits main gas valve to stay open only when the burners are proven to be lit
- If loss of flame occurs, gas valve closes, shutting off the gas to the burners
- LED indicates status and aids in troubleshooting

- Watchguard circuit on module automatically resets ignition controls after one hour of continuous thermostat demand after unit lockout, eliminating nuisance service calls
- Factory installed in the gas heating compartment

#### Limit Controls

- Redundant limit controls with fixed temperature setting
- Protects heat exchanger and other components from overheating

#### Safety Switches

- Flame roll-out switch
- Flame sensor
- Combustion air inducer proving switch
- Protects system operation

#### Two-Stage Gas Heat

- Two-Stage gas valve adjusts heat for low and high output

**NOTE** - Modulating Gas Heat may be ordered as a factory installed option. See Options/Accessories table.

## FEATURES AND BENEFITS

### HEATING SYSTEM (Continued)

#### Required Selections

##### Gas Input Choice - Order one:

- Standard Gas Heat - 84,500-130,000 Btuh
- Medium Gas Heat - 117,000-180,000 Btuh
- High Gas Heat - 156,000-240,000 Btuh

#### Options/Accessories

##### Factory Installed

##### Modulating Gas Heat

- Modulating gas valve adjusts heat output in real time based on demand for smoother temperature control
- Includes two factory-installed sensors:
  - Mixed Air Sensor
  - Indirect Sensing Discharge Air Temperature Sensor

**NOTE** - Modulating Gas Heat for Horizontal Applications requires a Remote Discharge Air Temperature Sensor / Fresh Air Tempering. Sensor is shipped with the unit for field installation if unit is configured at the factory. Sensor must be ordered separately for field installation if unit is not factory configured.

##### Stainless Steel Heat Exchanger

- Required if mixed air temperature is below 45°F

##### Field Installed

##### Bottom Gas Piping Kit

- Allows bottom gas entry

##### Combustion Air Intake Extensions

- Recommended for use with existing flue extension kits in areas where high snow areas can block intake air

##### Low Temperature Vestibule Heater

- Electric heater automatically controls minimum temperature in gas burner compartment when temperature is below -40°F
- CSA certified to allow operation of unit down to -60°F

##### LPG/Propane Kit

- Conversion kit to field change over units from Natural Gas to LPG/Propane
- Includes gas valve conversion parts for both two-stage and modulating

##### Vertical Vent Extension Kit

- Use to exhaust flue gases vertically above unit
- Required when unit vent is too close to fresh air intakes per building codes
- Also prevents ice formation on intake louvers
- Kit contains vent transition, vent tee, drain cap and installation hardware

**NOTE** - Straight vent pipes (4 in. B-Vent) and caps are not furnished and must be field supplied. Refer to kit instructions for additional information.

### COOLING SYSTEM

- Designed to maximize sensible and latent cooling performance at design conditions
- System can operate from 0°F to 125°F without any additional controls

##### R-454B Refrigerant

- Low GWP (Global Warming Potential)
- Zero ODP (Ozone Depletion Potential)
- Low Toxicity/Lower Flammability - A2L
- Unit is factory pre-charged

## 2 Dual Compressors

Cooling system consists of one variable capacity scroll compressor and one fixed capacity scroll compressor

##### Variable Capacity Scroll Compressor

- High performance, reliability and quiet operation
- Operates on a variable frequency determined to vary capacity based on the cooling load required

##### Fixed Capacity Scroll Compressor

- High performance, reliability and quiet operation
- Resiliently mounted on rubber grommets for quiet operation

##### Compressor Crankcase Heaters

- Protects against refrigerant migration that can occur during low ambient operation or during extended off cycles

##### DC Inverter Control (for Variable Capacity Compressor)

- Converts AC line voltage into filtered variable DC voltage
- Provides continuous compressor operation, while adjusting the capacity according to discharge air temperature
- Adjusts compressor output in increments as small as 1%
- Prevents frequent changes in capacity and ensures efficient, economical operation
- Power Factor Correction (PFC) circuit monitors the DC bus for high, low and abnormal voltage conditions to protect the compressor
- Two LEDs (red and green) indicate inverter operating status and aid in troubleshooting
- Noise filter reduces unwanted electromagnetic interference (EMI)
- Inverter reactor adds inductance to the line between the inverter and the compressor to limit current rise and protect the compressor

##### Thermal Expansion Valves

- Ensures optimal performance throughout the application range
- Removable element head

##### Filter/Driers

- High capacity filter/drier protects the system from dirt and moisture

##### High Pressure Switches

- Protects the system from high pressure conditions

##### Low Pressure Switches

- Protects the compressors from low pressure conditions such as low refrigerant charge or low/no airflow

## FEATURES AND BENEFITS

### **COOLING SYSTEM (continued)**

#### **Diagnostic and Sensor System**

- Multiple thermistors continuously monitor the refrigeration system, providing optimum performance and complete circuit protection at all operating conditions

#### **Indoor Coil Freeze Protection**

- Protects the evaporator coil from damaging ice build-up due to conditions such as low/no airflow or low refrigerant charge

### **3 Condenser Coil - Environ™ Coil System**

- Lightweight, all aluminum brazed fin construction
- Constructed of three components
  - A flat extrusion tube
  - Fins in-between the flat extrusion tube
  - Four refrigerant manifolds

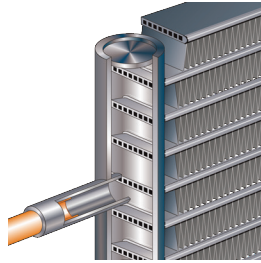

#### **Environ™ Coil System Features:**

- Improved heat transfer performance due to high primary surface area (flat tubes) versus secondary surface (fins)
- Smaller internal volume (reduced refrigerant charge)
- High durability
- All aluminum construction
- Fewer brazed joints
- Compact design
- Reduced unit weight
- Easy maintenance/cleaning
- Mounting brackets with rubber inserts secure coil to unit providing vibration dampening and corrosion protection

#### **Evaporator Coil**

- Copper tube construction
- Enhanced rippled-edge aluminum fins
- Flared shoulder tubing connections
- Silver soldered construction
- Cross-row circuiting with rifled copper tubing

#### **Anti-Microbial Condensate Drain Pan**

- Plastic pan, sloped to meet drainage requirements per ASHRAE 62.1
- Anti-Microbial additive resists growth of mold and mildew on drain pan, which improves indoor air quality and reduces drain line blockage
- Side or bottom drain connections
- Reversible to allow connection at back of unit

#### **Outdoor Coil Fans**

- PVC coated fan guard furnished

### **4 Variable-Speed ECM Outdoor Coil Fan Motors**

- Fan speed is directly controlled by the Lennox® CORE Unit Controller
- Thermal overload protected
- Totally enclosed
- Permanently lubricated ball bearings

- Shaft up
- Wire basket mount

### **Options/Accessories**

#### **Factory or Field Installed**

##### **Condensate Drain Trap**

- Constructed of PVC (factory or field) or copper (field only)

**NOTE** - Trap is field installed only; PVC version may be factory ordered to ship with unit.

##### **Drain Pan Overflow Switch**

- Monitors condensate level in drain pan
- Shuts down unit if drain becomes clogged

#### **LOW GWP REFRIGERANT DETECTION SYSTEM (RDS)**

- Complies with UL 60335-2-40 approved standard
- Required for all systems using R-454B refrigerant
- Factory installed on all units
- Consists of a refrigerant detection sensor(s) and a mitigation control
- Ensures safe operation for systems equipped with R-454B refrigerant
- Sensor(s) monitors indoor coil area for R-454B refrigerant
- If R-454B refrigerant is detected the refrigerant detection system will prevent compressor and heating operation until R-454B refrigerant is no longer detected
- Refrigeration detection system energizes blower if any R-454B refrigerant is detected to mitigate any concentrations of refrigerant from the unit and the system

## FEATURES AND BENEFITS

### CABINET

#### 5 Construction

- Heavy-gauge steel panels
- Full perimeter heavy-gauge galvanized steel base rail
- Base rails have rigging holes
- Three sides of the base rail have forklift slots
- Raised edges around duct and power entry openings in the bottom of the unit for water protection

#### Airflow Choice

- Units are shipped in downflow (vertical) configuration

**NOTE** - Units can be field converted to horizontal airflow with Horizontal Discharge Kit.

#### Duct Flanges

- Provided for horizontal duct attachment

#### Power Entry

- Electrical lines can be routed through the unit base or through horizontal access knock-outs

#### Exterior Panels

- Constructed of heavy-gauge, galvanized steel
- Textured pre-paint with polyurethane finish
- Cyclic salt fog and UV exposure up to 1680 hours per ASTM D5894

#### Insulation

- Fully insulated with non-hygroscopic fiberglass insulation (conditioned areas)
- Unit base is fully insulated
- Base insulation serves as an air seal to the roof curb, eliminating the need to add a seal during installation

#### 6 Hinged Access Panels

- Tool-less access
- Filter section
- Blower/heating section
- Compressor/controls section
- Panel seals and quarter-turn latching handles provide a tight air and water seal

### Required Selections

#### Airflow Configuration

- Specify downflow or horizontal

### Options/Accessories

#### **Factory or Field Installed**

##### Combination Coil/Hail Guards

- Heavy gauge steel frame
- Painted to match cabinet
- Expanded metal mesh protects outdoor coil

##### Return Air Adaptor Plate

- For same size LCA/LGA/LHA, LCC/LGC/LHC and TCA/TGA/THA unit replacement
- Installs on return air opening in unit to match return air opening on existing roof curbs
- Also see Accessory Air Resistance table

#### **Factory Installed**

##### Corrosion Protection

- Completely flexible immersed coating
- Electrodeposited dry film process (AST ElectroFin E-Coat)
- ASTM B117 / DIN 53167 Salt Spray - 15,000+ hours
- ASTM G85 Annex A3 SWAAT Modified Salt Spray - 3000 hours
- VA Master Construction Specification Division 23 for High Humidity Installations
- CID AA-52474A (GSA)
- Indoor Corrosion Protection:
  - Coated coil
  - Coated reheat coil (Humiditrol®+)
  - Painted blower housing
  - Painted indoor base
- Outdoor Corrosion Protection:
  - Coated coil
  - Painted outdoor base

#### **Field Installed**

##### Horizontal Discharge Kit

- Consists of duct covers to block off downflow supply and return air openings for horizontal applications
- Also includes return air duct flanges for end return air when Economizer is used in horizontal applications

**NOTE** - When configuring unit for horizontal application with Economizer, a separate Horizontal Barometric Relief Damper with Hood must be ordered separately for installation in the return air duct.

##### Burglar Bars

- Heavy gauge galvanized frame
- Fully welded
- 3/4 in. bar meets ASTM specification
- Frame meets ASTM A446, A525, A526 and A527 specification
- Burglar bars designed to fit ductwork

## FEATURES AND BENEFITS

### **BLOWER**

#### **7 DirectPlus™ Direct Drive ECM Blower System**

- High-efficiency, variable-speed ECM (electronically commutated) motor
- Eliminates the need for a separate variable-frequency drive
- SZVAV equipped models modulate the amount of supply blower airflow according to cooling demand, heating demand, ventilation demand or smoke alarm
- The amount of airflow for each stage can be set according to a parameter in the Lennox® CORE Unit Controller
- Unit is shipped from the factory with preset airflows
- Fully variable speed motor modulates to maximize system efficiency
- Combines the motor and electronics into one unit
- Aerodynamically optimized impeller
- Backward curved blades mounted directly onto the rotor



- Air inlet grill reduces indoor sound levels without affecting air performance



#### **Blower Proving Switch**

- Monitors blower operation, shuts down unit if blower fails

#### **Supply Static Pressure Transducer (VAV Models Only)**

- Sends information to the Lennox® CORE Unit Controller to control blower speed to the desired supply duct static pressure
- Shipped with the unit for remote field installation in the supply duct

### **Required Selections**

#### **Blower Selection**

- SZVAV (Single Zone Variable Air Volume) controls the speed of the blower based on the cooling and heating demands
- VAV (Variable Air Volume) blower varies the air volume to maintain a constant supply duct static pressure

### **ELECTRICAL**

#### **SmartWire™ System**

- Keyed and color-coded wiring connectors prevent miswiring
- Wire coloring scheme is standardized across all models
- Each connection is intuitively labeled to make troubleshooting and servicing quick and easy

#### **Electrical Plugs**

- Positive connection electrical plugs are used to connect common accessories or maintenance parts for easy removal or installation

#### **Phase/Voltage Detection**

- Monitors power supply to ensure phase is correct at unit start-up
- If phase is incorrect, the unit will not start and an alarm code is reported to the unit controller
- Protects unit from being started with incorrect phasing which could lead to issues such as compressors running backwards
- Voltage detection monitors power supply voltage to ensure proper voltage
- If voltage is not correct (over/under voltage conditions) the unit will not start and an alarm code is reported to the unit controller

### **Required Selections**

#### **Voltage Choice**

- Specify when ordering base unit

### **Options/Accessories**

#### **Factory Installed**

##### **Circuit Breakers**

- HACR type
- For overload and short circuit protection
- Factory wired and mounted in the power entry panel
- Current sensitive and temperature activated
- Manual reset

##### **Short-Circuit Current Rating (SCCR)**

- Higher short circuit protection up to 100kA

**NOTE** - Disconnect Switch is furnished and factory installed with High SCCR option.

#### **Factory or Field Installed**

##### **Disconnect Switch**

- Accessible outside of unit
- Spring loaded weatherproof cover furnished

##### **GFI Service Outlets (2)**

- 115V ground fault circuit interrupter (GFCI) type
- Non-powered, field-wired

#### **Field Installed**

##### **GFI Weatherproof Cover**

- Single-gang cover
- Heavy-duty UV-resistant polycarbonate case construction
- Hinged base cover with gasket

## FEATURES AND BENEFITS

### INDOOR AIR QUALITY

#### 8 Air Filters

- Disposable 2 inch MERV 4 filters furnished as standard

#### Options/Accessories

#### Factory or Field Installed

##### Healthy Climate® High Efficiency Air Filters

- Disposable MERV 8, MERV 13 or MERV 16 (Minimum Efficiency Reporting Value based on ASHRAE 52.2) efficiency 2-inch pleated filters

#### Field Installed

##### Healthy Climate® UVC Germicidal Lamps

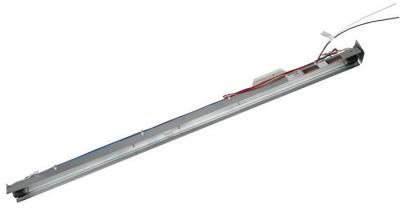

- Germicidal lamps emit ultra-violet (UV-C) energy, which has been proven to be effective in reducing microbes such as viruses, bacteria, yeasts, and molds
- This process either destroys the organism or controls its ability to reproduce
- UV-C energy greatly reduces the growth and proliferation of mold and other bioaerosols (bacteria and viruses) on illuminated surfaces (particularly coil and drain pan)
- Installed in the blower/evaporator coil section
- Safety interlock switch automatically shuts off power to the UVC light when panel is removed
- Interlock switch is factory installed or field installed in the blower/evaporator coil section panel
- All necessary hardware for installation is included
- Lamps operate on 110/230V, 1 phase power supply

**NOTE** - For 460V and 575V units, field installed lamps utilize jumpers to the outdoor fan transformer for voltage needed. See the installation Instructions.

- Approved by ETL

##### Needlepoint Bipolar Ionization (NPBI) Kit

- NPBI technology integrates with system controls for effective air treatment
- Ionization has been shown to effectively reduce harmful pathogens, pollutants and odors

**NOTE** - Please visit [www.sciencedirect.com](http://www.sciencedirect.com) for additional information.

- Brush-type ionizer introduces a high concentration of both positive and negative ions into the airstream
- These bipolar ions are then dispersed into the occupied space through the duct system proactively reducing the airborne contaminants
- Ions travel within the building air stream and attach to particles, pathogens, and gas molecules, making them larger and easier to capture in the filtration system
- UL 2998 certified for zero ozone emission

##### Indoor Air Quality (CO<sub>2</sub>) Sensors

- Monitors CO<sub>2</sub> levels, reports to the Lennox® CORE Unit Controller which adjusts Economizer dampers as needed

##### Replacement Filter Media Kit With Frame

- Replaces existing pleated filter media
- Includes washable metal mesh screen and metal frame with clip for holding replaceable non-pleated filter

## CONTROL SYSTEM

### LENNOX® CORE CONTROL SYSTEM

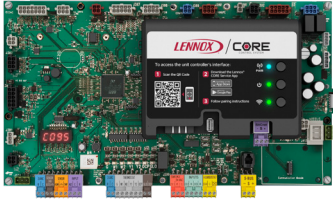

The Lennox® CORE Control System is designed to accelerate equipment install and service. Standard with all Model L™ rooftop units, control system integrates key technologies that lower installation costs, drive system efficiency, and protect your investments.

- 9 The Lennox® CORE Unit Controller is a microprocessor-based controller that provides flexible control of all unit functions.

#### CORE Mobile Service App

- Guided Setup with progress indicators, detailed help, and exportable summaries to manage simple, trouble-free setup, reducing commissioning times
- Enhanced Test Functionality provides real-time sensor readings, trending, and reports that enable easy troubleshooting
- Ability to set and configure parameters of the CORE Control System to manage sequence of operation
- Economizer test function ensures economizer is operating correctly



#### Additional Features:

- Built-In 7-Segment Display shows Unit Status and active alarms for easy troubleshooting
- Buttons for test and clearing delays
- SmartWire™ System with keyed and removable screw terminals ensure correct field wiring
- Built-in BACnet MS/TP and IP allow open integration to building management systems.
- Two-port Ethernet Switch enables daisy chaining for BACnet IP and automatic firmware updates

**NOTE** - Unit Internet Connection required.

- Profile setup copies key settings between units with the same configuration to reduce setup time
- USB port allows a technician to download and transfer unit information to help verify service was performed
- USB software updates on the Lennox® CORE Unit Controller enhance functionality without the need to change components
- Unit Controller Software

#### Configurable Built-In Functions

- Full modulation of variable speed compressor for discharge air temperature control in room sensor or thermostat mode
- Discharge Air Cooling Control

- Up to three distinct Cooling Airflows in Thermostat Mode.
- Programmable independent heating, ventilation and cooling blower speeds
- Discharge Air Heating Control
- Economizer Control Options (See Economizer / Exhaust Air / Outdoor Air sections)
- Exhaust Fan Control Modes for fresh air damper position
- Configurable Morning Warm-up
- Night Setback Mode
- Fresh Air Tempering for Improved Ventilation
- Demand Control Ventilation
- Low Ambient Controls for operation down to 0°F
- Humiditrol®+ Operation
- Enhanced Dehumidification (Latent Demand Control without reheat)

#### Component Protection / Unit Safeguards:

- Compressor Time-Off Delay
- Adjustable Blower On/Off Delay
- Return Air Temperature Limit Control
- Safety Switch Input allows Controller to respond to a external safety switch trip
- Service Relay Output
- Thermostat Bounce Delay
- Smoke Alarm Mode has four choices (unit off, positive pressure, negative pressure, purge)
- "Strike Three" Protection
- Gas Valve Time Delay Between First and Second Stage
- Minimum Compressor Run Time

#### Control Methods / Interfaces:

- DDC and 24V Thermostat
- BACnet MS/TP and IP
- LONTalk (Factory and Field Option)
- Lennox SBUS
- Zone Temperature Sensor Input
- Dehumidistat and Humidity Sensor Inputs
- Indoor Air Quality Inputs (2)
- Built-in Control Parameter Defaults
- Permanent Diagnostic Code Storage
- Field Adjustable Control Parameters (Over 200 settings)
- Multiple Configurable Digital Inputs
- LED Indicators
- PC Interface connects the Lennox® CORE Unit Controller to a PC with the Lennox Unit Controller Software

**NOTE** - Lennox® CORE Control System features vary with the type of rooftop unit in which the control is installed.

## CONTROL SYSTEM

### LENNOX® CORE CONTROL SYSTEM (continued)

#### Controls Options

##### Factory or Field Installed

###### Dirty Filter Switch

- Senses static pressure increase and issues alarm if necessary

###### Fresh Air Tempering

- Used in applications with high outside air requirements
- Controller energizes the first stage heat as needed to maintain a minimum supply air temperature for comfort, regardless of the thermostat demand
- When ordered as a factory option, sensor ships with the unit for field installation

###### Smoke Detector

- Photoelectric type
- Installed in supply air section, return air section or both sections
- Available with power board and single sensor (supply or return) or power board and two sensors (supply and return)
- Power board located in unit control compartment

### COMMERCIAL CONTROL SYSTEMS

#### Interoperability via BACnet® or LonTalk® Protocols

- Communication compatible with third-party automation systems that support the BACnet Application Specific Controller device profile, LonMark® Space Comfort Controller functional profile, or LonMark Discharge Air Controller functional profile

#### Field Installed

##### Thermostats and Rom Sensors

- Control system and thermostat options, see page 14

## OPTIONS / ACCESSORIES

### ECONOMIZER

- Economizer operation is set and controlled by the Lennox® CORE Unit Controller
- Simple plug-in connections from Economizer to unit controller for easy installation
- All Model L™ rooftop units are equipped with factory installed CEC Title 24 approved sensors for outside, return and discharge air temperature monitoring

**NOTE** - Optional sensors may be used instead of unit sensors to determine whether outdoor air is suitable for free cooling. See Options/Accessories table.

#### Factory or Field Installed

##### High Performance Economizer

- Approved for California Title 24 building standards
- Low leakage dampers are Air Movement and Control Association International (AMCA) Class 1A Certified - Maximum 3 CFM per sq. ft. leakage at 1 in. w.g.
- ASHRAE 90.1 compliant
- Downflow or Horizontal with Outdoor Air Hood
- Outdoor Air Hood is included when economizer is factory installed and is furnished with economizer when ordered for field installation
- Barometric Relief Dampers with Exhaust Hood are also furnished
- Linked damper action
- High torque 24-volt fully-modulating spring return damper motor
- Return air and outdoor air dampers
- Plug-in connections to unit
- Barometric Relief Dampers with Exhaust Hood are also furnished

**NOTE** - Horizontal applications use furnished outdoor air hood and barometric relief dampers with exhaust hood. Requires optional Horizontal Discharge Kit. See dimension drawing on page 36.

Horizontal applications in reduced spaces requires optional Horizontal Low Profile Barometric Relief Dampers with Exhaust Hood and Horizontal Discharge Kit. See dimension drawing on page 37.

**NOTE** - High Performance Economizers are not approved for use with enthalpy controls in Title 24 applications.

**NOTE** - The Free Cooling setpoint for Title 24 applications must be set based on the Climate Zone where the system is installed. See Section 140.4 "Prescriptive Requirements for Space Conditioning Systems" of the California Energy Commission's 2022 Building Energy Efficiency Standards.

**NOTE** - Refer to Installation Instructions for complete setup information.

## OPTIONS / ACCESSORIES

### **ECONOMIZER (continued)**

#### **Factory or Field Installed (continued)**

##### **Differential Sensible Control**

- Factory setting
- Uses outdoor air and return air sensors that are furnished with the unit
- The Lennox® CORE Unit Controller compares outdoor air temperature with return air
- When the outdoor air is below the configured setpoint and cooler than return air, the controller activates the Economizer

**NOTE** - Differential Sensible Control can be configured in the field to provide Offset Differential Sensible Control or Single Sensible Control.

**NOTE** - In Offset Differential Sensible Control mode, the Economizer is enabled if the temperature differential (offset) between outdoor air and return air reaches the configured setpoint. In Single Sensible Control mode, the Economizer is enabled when outdoor air temperature falls below the configured setpoint.

##### **Global Control**

- The unit controller communicates with a DDC system with one global sensor (enthalpy or sensible)
- Determines whether outside air is suitable for free cooling on all units connected to the control system
- Sensor must be field provided

##### **Single Enthalpy Temperature Control (Not for Title 24)**

- Outdoor air enthalpy sensor enables Economizer if the outdoor enthalpy is less than the setpoint of the control

##### **Differential Enthalpy Control (Not for Title 24)**

- Order two Single Enthalpy Controls
- One is field installed in the return air section
- One is installed in the outdoor air section
- Allows the Economizer control to select between outdoor air or return air, whichever has lower enthalpy

#### **Field Installed**

##### **Outdoor Air CFM Control**

- Maintains constant outdoor air volume levels on the supply air fan and varying unit airflows
- Velocity sensor located in the rooftop unit outdoor air section, the Lennox® CORE Unit Controller changes the Economizer position to help minimize the effect of supply fan speed changes on outdoor air volume levels
- Setpoint for outdoor air volume is established by field testing

**NOTE** - Not available with Demand Control Ventilation (CO<sub>2</sub> Sensor) or Building Pressure Control.

##### **Building Pressure Control**

- Maintains constant building pressure level
- Includes a static pressure transducer and outdoor static pressure assembly
- Using differential pressure information between the outdoor air and the building air, the Lennox® CORE Unit Controller changes the Economizer position to help maintain a constant building pressure

**NOTE** - Not available with Demand Control Ventilation (CO<sub>2</sub> Sensor) or Outdoor Air CFM Control.

#### **EXHAUST**

##### **Factory or Field Installed**

##### **Power Exhaust Fan**

- Installs internal to unit for downflow applications only with Economizer option
- Provides exhaust air pressure relief
- Interlocked to run when supply air blower is operating
- Fan runs when outdoor air dampers are 50% open (adjustable)
- Motor is overload protected
- Fan is 20 in. diameter
- Five blades
- One 1/3 HP motor

**NOTE** - Requires Economizer with furnished Downflow Barometric Relief Dampers with Exhaust Hood.

##### **Field Installed**

##### **Horizontal Low Profile Barometric Relief Dampers**

- For use when unit is configured for horizontal applications requiring an economizer in a reduced space
- Allows relief of excess air
- Aluminum blade dampers prevent blow back and outdoor air infiltration during off cycle
- Field installed in return air duct
- Bird screen and hood furnished

**NOTE** - Requires Horizontal Discharge Kit.

## OPTIONS / ACCESSORIES

### **OUTDOOR AIR**

#### **Factory or Field Installed**

##### **Motorized Outdoor Air Dampers**

- Linked mechanical dampers
- Fully modulating spring return damper motor with plug-in connection
- 0 to 25% (fixed) outdoor air adjustable
- Installs in unit
- Outdoor air hood with bird screen included

**NOTE** - Outdoor Air Hood is shipped separately in the unit with factory installed dampers for field installation.

#### **Field Installed**

##### **Manual Outdoor Air Damper**

- Adjustable slide damper
- Installed in unit
- Outdoor air hood with bird screen included

### **ROOF CURBS**

#### **Field Installed**

- Nailer strip furnished (downflow only)
- Mates to unit
- US National Roofing Contractors Approved
- Shipped knocked down

#### **Hybrid Roof Curbs, Downflow**

- Interlocking tabs fasten corners together
- No tools required for assembly
- Can also be fastened together with furnished hardware
- Available in 8, 14, 18, and 24 inch heights

#### **Adjustable Pitch Curb**

- Fully adjustable pitch curbs (3/4 in. per foot in any direction) provide a level platform for rooftop units allowing flexible installations on roofs with uneven or sloped angles
- Interlocking tabs fasten corners together
- No tools required for assembly
- Hardware is furnished to connect upper curb with lower curb
- Available in 14 inch height

#### **Adaptor Curbs (not shown)**

- Curbs are regionally sourced
- Dimensions vary based upon the source

**NOTE** - Contact your local sales representative for a detailed cut sheet with applicable dimensions.

### **CEILING DIFFUSERS**

#### **Field Installed**

##### **Ceiling Diffusers (Flush or Step-Down)**

- White powder coat finish on diffuser face and grilles
- Insulated UL listed duct liner
- Diffuser box has collars for duct connection
- Step-down diffusers have double deflection blades
- Flush diffusers have fixed blades
- Provisions for suspending
- Internally sealed to prevent recirculation
- Removable return air grille
- Adapts to T-bar ceiling grids or plaster ceilings

##### **Transitions (Supply and Return)**

- Used with diffusers
- Installs in roof curb
- Galvanized steel construction
- Flanges furnished for duct connection to diffusers
- Fully insulated

## HUMIDITROL®+ DEHUMIDIFICATION SYSTEM OPTION

### OVERVIEW

- Factory installed option designed to control humidity
- 10 • Humiditrol®+ utilizes advanced control algorithms, variable speed technology and a reheat coil to efficiently control humidity levels independent of room temperature
- Provides dehumidification on demand using ASHRAE 90.1 recommended method for comfort conditioning humidity control
- Unit comes equipped with one row reheat coil and solenoid valve

**NOTE** - A dehumidification demand from a relative humidity sensor, dehumidistat, a DDC controller or building automation system is required to control humidity

### BENEFITS

- Improves indoor air quality
- Discharge air control for overcool protection
- Adjustable discharge air temperature setpoint
- Energy efficient dehumidification
- Modulating latent and sensible capacity
- Helps prevent damage due to high humidity levels
- Improves comfort levels by reducing space humidity levels

### OPERATION

#### No Dehumidification Demand

- The unit will operate conventionally whenever there is a demand for cooling or heating and no dehumidification demand
- Free cooling is only permitted when there is no demand for dehumidification

#### Dehumidification Demand Only

- Reheat operation will initiate on a dehumidification demand and does not require a cooling demand
- The unit will operate in hot gas reheat dehumidification mode until the relative humidity of the conditioned space is below the setpoint
- A solenoid valve diverts hot gas from the compressor to the reheat coil
- The cooled and dehumidified air from the evaporator is reheated as it passes through the reheat coil
- The de-superheated and partially condensed refrigerant continues to the outdoor condenser coil where condensing is completed
- Unit will continue to operate in this mode until the dehumidification demand is satisfied
- The reheat coil is sized to provide optimal reheat performance without overheating supply air
- The compressor will modulate based on dehumidification load
- The outdoor fans modulate speed to provide discharge air temperature control in reheat mode

#### Dehumidification and Cooling Demand (Thermostat/ Room Sensor Application)

- If both a dehumidification and a cooling demand occur, the system will operate in cooling until the cooling demand is satisfied
- Then the system will energize the dehumidification mode

**NOTE** - See Sequence of Operation for additional information.

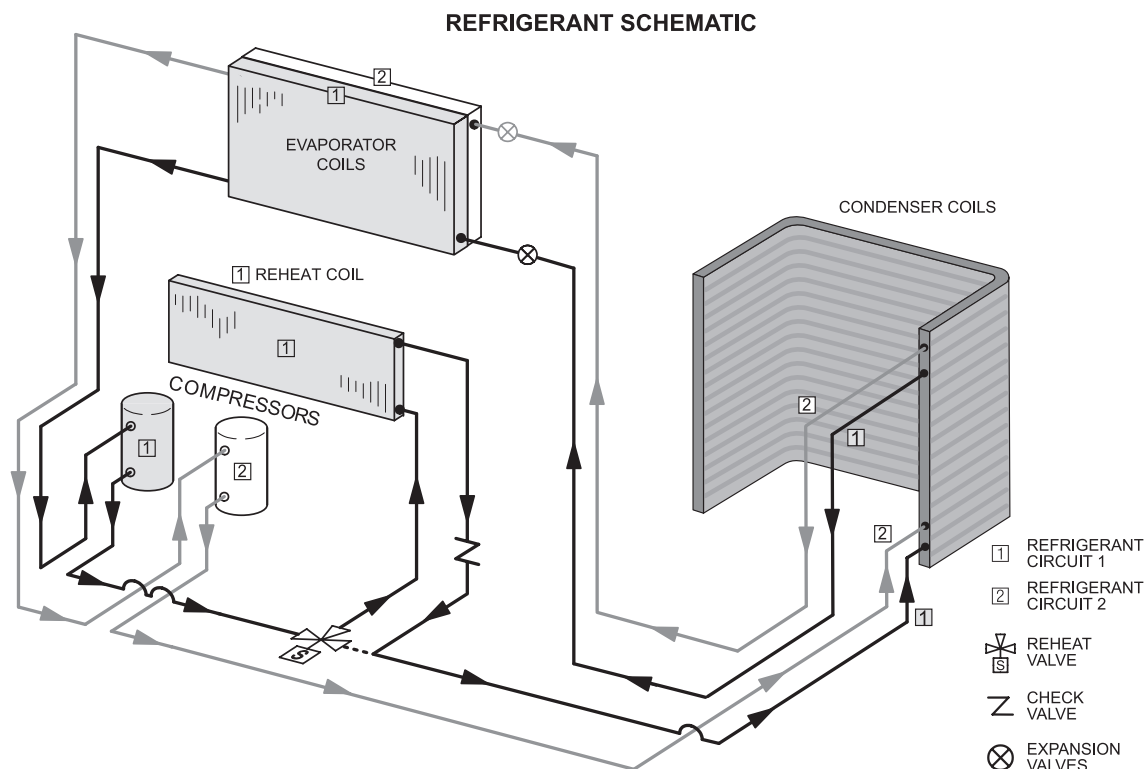

## OPTIONAL CONVENTIONAL TEMPERATURE CONTROL SYSTEMS

### CS8500 Commercial 7-Day Programmable Thermostat

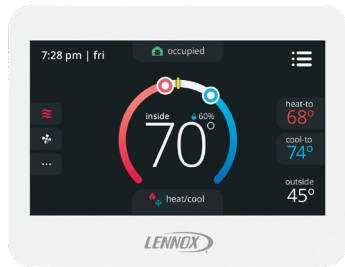

- Fully Communicating Sensor
- Full Color Touchscreen Interface
- Variable Speed System Control (On Compatible Units)
- Up To 4 Heat / 4 Cool
- Built-In Sensors For Temperature, Humidity And Optional CO<sub>2</sub>
- Remote Sensor Options For Occupancy, Temperature
- BACnet Capable Options
- 5-2 or 7-Day Scheduling
- Smooth Setback Recovery
- Heat/Cool Auto-Changeover
- Four-Wire Installation
- FDD, ASHRAE, IECC Compliant

### CS7500 Commercial 7-Day Programmable Thermostat



- Premium Universal Thermostat
- Full Color Touchscreen Interface
- Up To 4 Heat / 3 Cool
- Built-In Sensors For Temperature and Humidity
- Remote Sensors Options For Temperature, Discharge Air, Outdoor Air
- 5-2 or 7-Day Scheduling
- Smooth Setback Recovery
- Heat/Cool Auto-Changeover
- FDD, ASHRAE, IECC Compliant

### CS3000 Commercial 5-2 Day Programmable Thermostat



- Conventional Multi-Stage Thermostat
- Intuitive Display
- Push-Button Operation
- Up To 2 Heat / 2 Cool
- Built-In Temperature Sensor
- Remote Temperature Sensing
- Up to 5-2 Day Scheduling
- Smooth Setback Recovery
- Heat/Cool Auto-changeover

### Wired Temperature/Humidity Room Sensor (Non-Communicating)



- Terminal blocks for wiring connections
- Five-wire sensor connection
- Off-white plastic enclosure
- Non-adjustable
- Relative humidity range: 0 -100%
- +/- 3% Accuracy

## OPTIONAL CONVENTIONAL TEMPERATURE CONTROL SYSTEMS

Description	Order Number
<b>CS8500 Commercial 7 Day Programmable Thermostat</b>	
CS8500 7-Day Thermostat	No CO <sub>2</sub> Sensing <b>24K55</b>
	With CO <sub>2</sub> Sensing <b>24K53</b>
Sensors/Accessories	<sup>1</sup> Remote non-adjustable wall-mount 10k <b>47W37</b>
	<sup>1</sup> Remote non-adjustable wall-mount 11k <b>94L61</b>
<b>Sysbus Network Cable (Yellow) for CS8500 and LCS-5030 Wired Room Sensor</b>	
Twisted pair 100% shielded communication cable, Red and Black	500 ft. box <b>27M19</b>
22 AWG, yellow jacket, rated at 75°C, 300V, Plenum rated	1000 ft. box <b>94L63</b>
Insulation - Low smoke PVC, NEC, CMP	2500 ft. roll <b>68M25</b>
<b>CS7500 Commercial 7-Day Programmable Thermostat</b>	
CS7500 7-Day Thermostat	<b>24K41</b>
Sensors/Accessories	<sup>2</sup> Remote non-adjustable wall-mount 20k <b>47W36</b>
	<sup>2</sup> Remote non-adjustable wall-mount 10k <b>47W37</b>
	Remote non-adjustable discharge air (duct mount) <b>19L22</b>
	Outdoor temperature sensor <b>X2658</b>
<b>CS3000 Commercial 5-2 Day Programmable Thermostat</b>	
CS3000 5-2 Day Thermostat	<b>11Y05</b>
Sensors/Accessories	Remote non-adjustable wall mount 10k averaging <b>47W37</b>
	Thermostat wall mounting plate <b>X2659</b>
<b>Universal Thermostat Guard with Lock (clear)</b>	
	Inside Dimensions (H x W x D) 5-7/8 x 8-3/8 x 3 in. <b>39P21</b>
<b>Temperature/Humidity Room Sensor</b>	
A335MT13AE1 Wired Temperature/Humidity Room Sensor (Non-Communicating)	<b>21W06</b>

<sup>1</sup> Up to nine of the same type remote temperature sensors can be connected in parallel.

<sup>2</sup> Remote wall-mount sensors can be applied in any of the following combinations:  
 One Sensor - (1) 47W36, Two Sensors - (2) 47W37, Three Sensors - (2) 47W36 and (1) 47W37  
 Four Sensors - (4) 47W36, Five Sensors - (3) 47W36 and (2) 47W37

## SEQUENCE OF OPERATION

### **COOLING**

#### **A-Two-Stage Thermostat**

1 - Economizer With Outdoor Air Suitable

##### **Y1 Demand**

- Compressors Off
- Blower Cooling Low
- Dampers Modulate

*NOTE - If dampers are at maximum open for five minutes, blower runs at cooling high.*

##### **Y2 Demand**

- Compressors Modulate
- Blower Cooling High
- Dampers Maximum Open

2 - No Economizer or Outdoor Air Not Suitable

##### **Y1 Demand**

- Compressors Modulate
- Blower Cooling Low
- Dampers Minimum Position

##### **Y2 Demand**

- Compressors Modulate
- Blower Cooling High
- Dampers Minimum Position

#### **B-Three-Stage Thermostat**

1 - Economizer With Outdoor Air Suitable

##### **Y1 Demand**

- Compressors Off
- Blowers Cooling Low
- Dampers Modulate

*NOTE - If dampers are at maximum open for five minutes, blower runs at cooling intermediate.*

##### **Y2 Demand**

- Compressors Modulate
- Blower Cooling Intermediate
- Dampers Maximum Open

##### **Y3 Demand**

- Compressors Modulate
- Blower Cooling High
- Dampers Maximum Open

## SEQUENCE OF OPERATION

### COOLING (CONTINUED)

2 - No Economizer or Outdoor Air Not Suitable

#### **Y1 Demand**

- Compressors Modulate
- Blower Cooling Low
- Dampers Minimum Position

#### **Y2 Demand**

- Compressors Modulate
- Blower Cooling Intermediate
- Dampers Minimum Position

#### **Y3 Demand**

- Compressors Modulate
- Blower Cooling High
- Dampers Minimum Position

### **C - Room Sensor**

1 - Economizer With Outdoor Air Suitable

- Compressors Off
- Blower Modulates
- Dampers Modulate

*NOTE - If dampers are at maximum open for five minutes, compressors are energized and the blower modulates.*

2 - No Economizer or Outdoor Air Not Suitable

- Compressors Modulate
- Blower Modulates
- Dampers Minimum Position

*NOTE - Free cooling is locked out when a dehumidification demand is received. The unit operates in dehumidification mode as if the outdoor air is not suitable.*

### HEATING - TWO-STAGE

**Two-Stage Heating Mode: Thermostat or Zone Sensor (Up to 2 stages W1, W2)**

#### **W1 Demand:**

Gas valve is open (stage 1 on units with 2 stage gas valve) and the supply fan operates at high speed

#### **W2 Demand:**

Gas valve is open (stage 2 on units with 2 stage gas valve) and the supply fan operates at high speed

### HEATING - MODULATING

#### **W1 or Low Heating Demand:**

Supply fan operates at low heating speed and Gas valve modulates to maintain Discharge Air Temperature (DAT) setpoint

#### **W2 or High Heating Demand:**

Supply fan operates at high heating speed and Gas valve modulates to maintain Discharge Air Temperature (DAT) setpoint

#### **Zone Sensor:**

Heating demand is based on delta and duration of Zone Air Temperature (ZAT) away from ZAT setpoint. Based on heating demand, supply fan modulates between low heating speed and high heating speed while gas valve modulates to maintain Discharge Air Temperature (DAT) setpoint as the blower speed changes

## SEQUENCE OF OPERATION

### **HUMIDITROL®+**

#### **A - Thermostat Mode With 24V Humidistat**

Dehumidification Demand (DI4) and No Cooling Demand

Compressor operates at 100%, blower and outdoor fans modulate to maintain indoor coil and discharge air temperatures, reheat valve is energized.

##### **Y1 and DI4 Demand**

Compressors are modulating, blower is on low, and the reheat valve is de-energized.

##### **Y2 and DI4 Demand**

Compressors are modulating, blower is on high, reheat valve is de-energized.

#### **B - Thermostat Mode With Zone Relative Humidity Sensor**

Dehumidification Demand (Zone Relative Humidity is greater than the relative humidity setpoint) and No Cooling Demand

Compressor modulates based on zone relative humidity, blower and outdoor fans modulate to maintain indoor coil and discharge air temperatures, reheat valve is energized.

Y1 and Dehumidification Demand

Compressors are modulating, blower is on low, and the reheat valve is de-energized.

Y2 and Dehumidification Demand

Compressors are modulating, blower is on high, reheat valve is de-energized.

#### **C - Room Sensor Mode With Humidistat**

Dehumidification Demand (DI4) and No Cooling Demand

Compressor 1 operates at 100%, blower and outdoor fans modulate to maintain indoor coil and discharge air temperatures, reheat valve is energized.

Cooling and Dehumidification Demand

Compressors are modulating, blower is modulating, reheat valve is de-energized.

#### **D - Room Sensor Mode With Zone Relative Humidity Sensor**

Dehumidification Demand (Zone Relative Humidity is greater than the relative humidity setpoint) and No Cooling Demand

Compressor 1 modulates based on zone relative humidity, blower and outdoor fans modulate to maintain indoor coil and discharge air temperatures, reheat valve is energized.

Cooling and Dehumidification Demand

Compressors are modulating, blower is modulating, and the reheat valve is de-energized.

## OPTIONS / ACCESSORIES

Item Description	Order Number	Size				
		092	102	120	150	
<b>COOLING SYSTEM</b>						
Condensate Drain Trap	PVC	<b>22H54</b>	OX	OX	OX	OX
	Copper	<b>76W27</b>	X	X	X	X
Corrosion Protection	Factory		O	O	O	O
Drain Pan Overflow Switch	<b>21Z07</b>		OX	OX	OX	OX
<b>HEATING SYSTEM</b>						
Bottom Gas Piping Kit	<b>54W95</b>		X	X	X	X
Combustion Air Intake Extensions	<b>19W51</b>		X	X	X	X
<sup>1</sup> Modulating Gas Heat	Factory		O	O	O	O
Gas Heat Input	Standard - 84,500-130,000 Btuh	Factory	O	O	O	O
	Medium - 117,000-180,000 Btuh	Factory	O	O	O	O
	High - 156,000-240,000 Btuh	Factory	O	O	O	O
LPG/Propane Conversion Kit	All Heat Sizes	<b>39J46</b>	X	X	X	X
Low Temperature Vestibule Heater	208/230V-3ph	<b>22A51</b>	X	X	X	X
	460V-3ph	<b>22A55</b>	X	X	X	X
	575V-3ph	<b>13X65</b>	X	X	X	X
Stainless Steel Heat Exchanger	Factory		O	O	O	O
Vertical Vent Extension Kit	<b>42W16</b>		X	X	X	X
<b>BLOWER - SUPPLY AIR</b>						
Blower	DirectPlus™ Direct Drive ECM Blower System with SZVAV	Factory	O	O	O	O
	DirectPlus™ Direct Drive ECM Blower System with VAV	Factory	O	O	O	O
<b>CABINET</b>						
Burglar Bars	<b>Y3355</b>		X	X	X	X
Combination Coil/Hail Guards	<b>24C85</b>		OX	OX	OX	OX
Horizontal Discharge Kit	<b>51W25</b>		X	X	X	X
Return Air Adaptor Plate (for same size LCA/LGA/LHA, LCC/LGC/LHC and TCA/TGA/THA unit replacement)	<b>54W96</b>		OX	OX	OX	OX
<b>CONTROLS</b>						
Commercial Controls	LonTalk® Module - For Lennox® CORE Control System	<b>54W27</b>	OX	OX	OX	OX
	Novar® LSE	Factory	O	O	O	O
Dirty Filter Switch	<b>53W67</b>		OX	OX	OX	OX
<sup>1</sup> Remote Discharge Air Temperature Sensor	<b>21Z08</b>		OX	OX	OX	OX
Fresh Air Tempering	<b>21Z08</b>		OX	OX	OX	OX
Smoke Detector - Supply or Return (Power board and one sensor)	<b>31A68</b>		OX	OX	OX	OX
Smoke Detector - Supply and Return (Power board and two sensors)	<b>31A69</b>		OX	OX	OX	OX

<sup>1</sup> Modulating Gas Heat for Horizontal Applications requires a Remote Discharge Air Temperature Sensor (21Z08). Sensor is shipped with the unit for field installation if unit is configured at the factory. Sensor must be ordered separately for field installation if unit is not factory configured.

NOTE - Catalog numbers shown are for ordering optional accessories if a field installed option is available.

OX - Configure To Order (Factory Installed) or Field Installed

O = Configure To Order (Factory Installed)

X = Field Installed

## OPTIONS / ACCESSORIES

Item Description	Order Number	Size				
		092	102	120	150	
<b>INDOOR AIR QUALITY</b>						
<b>Air Filters</b>						
Healthy Climate® High Efficiency Air Filters 20 x 25 x 2 in.	MERV 8 (Order 4)	<b>50W61</b>	OX	OX	OX	OX
	MERV 13 (Order 4)	<b>52W41</b>	OX	OX	OX	OX
	MERV 16 (Order 4)	<b>21U51</b>	OX	OX	OX	OX
Replacement Media Filter With Metal Mesh Frame 20 x 25 x 2 in. (includes non-pleated filter media)	(Order 4)	<b>Y3063</b>	X	X	X	X
<b>Indoor Air Quality (CO<sub>2</sub>) Sensors</b>						
Sensor - Wall-mount, off-white plastic cover with LCD display		<b>24C58</b>	X	X	X	X
Sensor - Wall-mount, off-white plastic cover, no display		<b>87N53</b>	X	X	X	X
Sensor - Black plastic case, LCD display, rated for plenum mounting		<b>87N52</b>	X	X	X	X
Sensor - Black plastic case, no display, rated for plenum mounting		<b>87N54</b>	X	X	X	X
CO <sub>2</sub> Sensor Duct Mounting Kit - for downflow applications		<b>23Y47</b>	X	X	X	X
Aspiration Box - for duct mounting non-plenum rated CO <sub>2</sub> sensors ( <b>24C58</b> )		<b>90N43</b>	X	X	X	X
<b>Needlepoint Bipolar Ionization (NPBI)</b>						
Needlepoint Bipolar Ionization (NPBI) Kit		<b>21U36</b>	X	X	X	X
<b>UVC Germicidal Lamps</b>						
<sup>1</sup> Healthy Climate® UVC Light Kit (110//230V-1ph)		<b>21A93</b>	X	X	X	X
<b>ELECTRICAL</b>						
Voltage 60 Hz	208/230V - 3 phase	Factory	O	O	O	O
	460V - 3 phase	Factory	O	O	O	O
	575V - 3 phase	Factory	O	O	O	O
HACR Circuit Breakers		Factory	O	O	O	O
<sup>2</sup> Short-Circuit Current Rating (SCCR) of 100kA (includes Phase/Voltage Detection)		Factory	O	O	O	O
Disconnect Switch	80 amp	<b>54W56</b>	OX	OX	OX	OX
GFI Service Outlets	15 amp non-powered, field-wired (208/230V, 460V only)	<b>74M70</b>	OX	OX	OX	OX
	<sup>3</sup> 20 amp non-powered, field-wired (208/230V, 460V, 575V)	<b>67E01</b>	X	X	X	X
	<sup>3</sup> 20 amp non-powered, field-wired (575V only)	Factory	O	O	O	O
Weatherproof Cover for GFI		<b>10C89</b>	X	X	X	X
<sup>2</sup> For 460V and 575V units, field installed lamps utilize jumpers to the outdoor fan transformer for voltage needed. See the installation Instructions. <sup>3</sup> Disconnect Switch is furnished and factory installed with High SCCR option. <sup>4</sup> Canada requires a minimum 20 amp circuit. Select 20 amp, non-powered, field wired GFI.						
NOTE - Catalog numbers shown are for ordering optional accessories if a field installed option is available. OX - Configure To Order (Factory Installed) or Field Installed O = Configure To Order (Factory Installed) X = Field Installed						

## OPTIONS / ACCESSORIES

Item Description	Order Number	Size				
		092	102	120	150	
<b>ECONOMIZER</b>						
<b>High Performance Economizer (Approved for California Title 24 Building Standards / AMCA Class 1A Certified)</b>						
High Performance Economizer (Downflow or Horizontal)	20U80	OX	OX	OX	OX	
Includes Economizer Dampers with Outdoor Air Hood and Barometric Relief Dampers with Exhaust Hood						
Downflow Applications - Use furnished Outdoor Air Hood and Barometric Relief Dampers with Exhaust Hood						
Horizontal Applications - Use furnished Outdoor Air Hood and Barometric Relief Dampers with Exhaust Hood - Order Horizontal Discharge Kit separately						
Horizontal Applications (reduced height) - Order Horizontal Low Profile Barometric Relief Dampers with Exhaust Hood and Horizontal Discharge Kit (51W25) separately						
<b>Horizontal Low Profile Barometric Relief Dampers</b>						
Horizontal Low Profile Barometric Relief Dampers With Exhaust Hood	53K04	X	X	X	X	
<b>Economizer Controls</b>						
Differential Enthalpy (Not for Title 24)	Order 2 21Z09	OX	OX	OX	OX	
Sensible Control	Sensor is Furnished Factory	O	O	O	O	
Single Enthalpy (Not for Title 24)	21Z09	OX	OX	OX	OX	
Global Control	Sensor Field Provided Factory	O	O	O	O	
Building Pressure Control	13J77	X	X	X	X	
Outdoor Air CFM Control	13J76	X	X	X	X	
<b>OUTDOOR AIR</b>						
<b>Outdoor Air Dampers</b>						
Motorized Dampers (Hood furnished)	14G28	OX	OX	OX	OX	
Manual Dampers (Hood furnished)	14G29	OX	OX	OX	OX	
<b>POWER EXHAUST</b>						
Standard Static	208/230V-3ph	53W44	OX	OX	OX	OX
	460V-3ph	53W45	OX	OX	OX	OX
	575V-3ph	53W46	OX	OX	OX	OX
<b>HUMIDITROL®+ HOT GAS REHEAT OPTION (SZVAV MODELS ONLY)</b>						
Humiditrol+ Dehumidification Option	Factory	O	O	O	O	
Humidity Sensor Kit, Remote mounted (required)	17M50	X	X	X	X	
<b>ROOF CURBS</b>						
<b>Hybrid Roof Curbs, Downflow</b>						
8 in. height	11F54	X	X	X	X	
14 in. height	11F55	X	X	X	X	
18 in. height	11F56	X	X	X	X	
24 in. height	11F57	X	X	X	X	
<b>Adjustable Pitch Curb, Downflow</b>						
14 in. height	54W50	X	X	X	X	
<b>CEILING DIFFUSERS</b>						
Step-Down - Order one	RTD11-95S	13K61	X			
	RTD11-135S	13K62		X	X	
	RTD11-185S	13K63			X	
Flush - Order one	FD11-95S	13K56	X			
	FD11-135S	13K57		X	X	
	FD11-185S	13K58			X	
Transitions (Supply and Return) - Order one	C1DIFF30B-1	12X65	X			
	C1DIFF31B-1	12X66		X	X	
	C1DIFF32B-1	12X67			X	

NOTE - Catalog numbers shown are for ordering optional accessories if a field installed option is available.

OX - Configure To Order (Factory Installed) or Field Installed

O = Configure To Order (Factory Installed)

X = Field Installed

SPECIFICATIONS				UNIT		
<b>Model</b>		<b>LGM092U5E</b>	<b>LGM102U5E</b>	<b>LGM120U5E</b>	<b>LGM150U5E</b>	
<b>Blower Type</b>		DirectPlus™ ECM Direct Drive with SZVAV	DirectPlus™ ECM Direct Drive with SZVAV	DirectPlus™ ECM Direct Drive with SZVAV	DirectPlus™ ECM Direct Drive with SZVAV	
<b>Model</b>		<b>LGM092U5P</b>	<b>LGM102U5P</b>	<b>LGM120U5P</b>	<b>LGM150U5P</b>	
<b>Blower Type</b>		DirectPlus™ ECM Direct Drive with VAV	DirectPlus™ ECM Direct Drive with VAV	DirectPlus™ ECM Direct Drive with VAV	DirectPlus™ ECM Direct Drive with VAV	
<b>Nominal Tonnage</b>		7.5 Ton	8.5 Ton	10 Ton	12.5 Ton	
<b>Efficiency Type</b>		Ultra-High	Ultra-High	Ultra-High	Ultra-High	
<b>Cooling Performance</b>	Gross Cooling Capacity (Btuh)	90,000	100,000	117,500	141,000	
	<sup>1</sup> Net Cooling Capacity (Btuh)	88,000	97,000	114,000	136,000	
	AHRI Rated Air Flow (cfm)	2800	3400	3600	4200	
	<sup>1</sup> IEER (Btuh/Watt)	21.0	21.0	20.7	19.5	
	<sup>1</sup> EER (Btuh/Watt)	12.5	12.5	12.0	10.8	
	Total Unit Power - kW	7.0	7.8	9.5	12.6	
<b>Sound Rating Number (minimum/maximum) dBA</b>		68 / 85	68 / 85	67 / 89	67 / 89	
<b>Refrigerant Charge</b>		Refrigerant Type R-454B				
	Without Reheat Option	Circuit 1	7 lbs. 5 oz.	7 lbs.. 5 oz.	8 lbs. 4 oz.	8 lbs. 2 oz.
		Circuit 2	5 lbs. 2 oz.	5 lbs. 2 oz.	4 lbs. 9 oz.	5 lbs. 12 oz.
	With Reheat Option	Circuit 1	8 lbs. 2 oz.	8 lbs. 2 oz.	8 lbs. 4 oz.	8 lbs. 2 oz.
		Circuit 2	4 lbs. 12 oz.	4 lbs. 12 oz.	4 lbs. 12 oz.	5 lbs. 14 oz.
<b>Gas Heating Options Available - See page 22</b>		Standard (2 Stage), Medium (2 Stage), High (2 Stage)				
<b>Compressor Type (number)</b>		Variable Capacity Scroll (1) Fixed Capacity Scroll (1)				
<b>Outdoor Coils</b>	Net face area - ft. <sup>2</sup>	26.7	26.7	26.7	26.7	
	Rows	1	1	1	1	
	Fins - in.	20	20	20	20	
<b>Outdoor Coil Fans</b>	Motor HP (number and type)	1/3 (2 ECM)	1/3 (2 ECM)	1/3 (2 ECM)	1/3 (2 ECM)	
	Rpm	300-900	300-1075	300-1075	300-1075	
	Watts	65-650	65-750	65-750	65-750	
	Diameter (Number) - in.	(2) 24	(2) 24	(2) 24	(2) 24	
	Blades	3	3	3	3	
	Total Air volume - cfm	6600	8800	8800	8800	
	<b>Indoor Coil</b>	Net face area - ft. <sup>2</sup>	13.54	13.54	13.54	13.54
Tube diameter - in.		3/8	3/8	3/8	3/8	
Number of rows		4	4	4	4	
Fins - in.		14	14	14	14	
Condensate drain size (NPT) - in.		(1) 1				
Expansion device type		Balanced Port Thermostatic Expansion Valve,removable power head				
<b>Indoor Blower</b>	Nominal motor HP	3.75 (ECM)	3.75 (ECM)	3.75 (ECM)	3.75 (ECM)	
	Blower wheel nominal diameter x width - in.	(1) 22 x 9	(1) 22 x 9	(1) 22 x 9	(1) 22 x 9	
<b>Filters</b>	Type of filter	MERV 4, Disposable				
	Number and size - in.	(4) 20 x 25 x 2				
<b>Line voltage data (Volts-Phase-Hz)</b>		208/230-3-60, 460-3-60, 575-3-60				

NOTE - Net capacity includes evaporator blower motor heat deduction. Gross capacity does not include evaporator blower motor heat deduction.

<sup>1</sup> AHRI Certified to AHRI Standard 340/360; 95°F outdoor air temperature and 80°F db/67°F wb entering evaporator air; minimum external duct static pressure.

SPECIFICATIONS			GAS HEAT		
Heat Input Type			Standard	Medium	High
Gas Heat Type			Two-Stage or Modulating		
Gas Heating Performance	Input - Btuh	Minimum	85,000	117,000	156,000
		Maximum	130,000	180,000	240,000
	Output - Btuh	Maximum	105,000	146,000	194,000
Temperature Rise Range - °F			15 - 45	30 - 60	40 - 70
Minimum Air Volume - cfm			2150	2250	2600
Thermal Efficiency			81%	81%	81%
Gas Supply Connections			3/4 in. NPT	3/4 in. NPT	3/4 in. NPT
Recommended Gas Supply Pressure - Nat. / LPG			7 in. w.g. / 11 in. w.g.		
Gas Supply Pressure Range			Min./Max. (Natural)	4.7 - 10.5 in. w.g.	
			Min./Max. (LPG)	10.8 - 13.5 in. w.g.	

NOTE - Modulating Gas Heat operates between the minimum and maximum gas heat inputs shown.

NOTE - Air volume may modulate below minimum volume if heat input is below maximum.

## HIGH ALTITUDE DERATE

**NOTE** - Units may be installed at altitudes up to 2000 feet above sea level without any modifications.

At altitudes above 2000 feet units must be derated to match gas manifold pressures shown in table below.

At altitudes above 4500 feet unit must be derated 4% for each 1000 feet above sea level.

**NOTE** - This is the only permissible derate for these units.

Refer to the Installation Instructions for more detailed information.

Heat Input Type	Altitude Feet	Gas Manifold Pressure in. w.g.		Input Rate (Btuh)
		Natural Gas	LPG/ Propane	
Standard	2001 - 4500	1.6 / 3.1	4.4 / 8.9	85,000 - 120,000
Medium	2001 - 4500	1.6 / 3.1	4.4 / 8.9	117,000 - 166,000
High	2001 - 4500	1.6 / 3.1	4.4 / 8.9	156,000 - 221,000

# COOLING RATINGS

NOTE – For Temperatures and Capacities not shown in tables, see bulletin – Cooling Unit Rating Table Correction Factor Data in Miscellaneous Engineering Data section.

## 7.5 TON - LGM092U5E/P (LOW COOLING) VARIABLE SPEED COMPRESSOR ONLY OPERATING

Entering Wet Bulb Temperature	Total Air Volume	Outdoor Air Temperature Entering Outdoor Coil																			
		65°F					75°F					85°F					95°F				
		Total Cool Cap.	Comp. Motor Input	Sensible To Total Ratio (S/T)			Total Cool Cap.	Comp. Motor Input	Sensible To Total Ratio (S/T)			Total Cool Cap.	Comp. Motor Input	Sensible To Total Ratio (S/T)			Total Cool Cap.	Comp. Motor Input	Sensible To Total Ratio (S/T)		
				Dry Bulb					Dry Bulb					Dry Bulb					Dry Bulb		
cfm	kBtuh	kW	75°F	80°F	85°F	kBtuh	kW	75°F	80°F	85°F	kBtuh	kW	75°F	80°F	85°F	kBtuh	kW	75°F	80°F	85°F	
63°F	800	51.31	2.84	0.62	0.7	0.78	49.09	3.23	0.62	0.71	0.79	47.28	3.65	0.62	0.71	0.8	44.96	4.1	0.62	0.71	0.8
	1335	61.38	2.79	0.67	0.78	0.9	58.97	3.23	0.68	0.8	0.91	56.35	3.68	0.68	0.8	0.92	53.84	4.16	0.69	0.82	0.94
	1875	67.22	2.76	0.73	0.88	0.99	64.36	3.22	0.75	0.89	0.99	61.52	3.69	0.76	0.91	0.99	58.57	4.19	0.77	0.93	0.99
67°F	800	54.3	2.83	0.51	0.59	0.67	52.43	3.23	0.51	0.59	0.67	50.19	3.66	0.51	0.59	0.68	47.89	4.12	0.5	0.59	0.68
	1335	65.35	2.78	0.54	0.65	0.75	62.69	3.22	0.54	0.65	0.76	60.1	3.69	0.54	0.66	0.77	57.29	4.18	0.55	0.66	0.78
	1875	71.52	2.74	0.58	0.71	0.84	68.54	3.21	0.58	0.72	0.86	65.01	3.7	0.58	0.73	0.87	62.26	4.21	0.59	0.74	0.89
71°F	800	57.85	2.82	0.42	0.49	0.57	55.58	3.23	0.41	0.49	0.56	53.37	3.67	0.4	0.49	0.57	51.28	4.14	0.4	0.48	0.57
	1335	69.27	2.75	0.42	0.52	0.62	66.41	3.21	0.42	0.52	0.63	63.46	3.7	0.42	0.52	0.64	60.48	4.2	0.41	0.52	0.64
	1875	75.59	2.71	0.44	0.56	0.69	72.14	3.21	0.43	0.57	0.7	68.92	3.71	0.43	0.57	0.7	65.66	4.23	0.43	0.58	0.72

NOTE - Compressor operating at maximum capacity.

## 7.5 TON - LGM092U5E/P (HIGH COOLING) BOTH COMPRESSORS OPERATING

Entering Wet Bulb Temperature	Total Air Volume	Outdoor Air Temperature Entering Outdoor Coil																			
		85°F					95°F					105°F					115°F				
		Total Cool Cap.	Comp. Motor Input	Sensible To Total Ratio (S/T)			Total Cool Cap.	Comp. Motor Input	Sensible To Total Ratio (S/T)			Total Cool Cap.	Comp. Motor Input	Sensible To Total Ratio (S/T)			Total Cool Cap.	Comp. Motor Input	Sensible To Total Ratio (S/T)		
				Dry Bulb					Dry Bulb					Dry Bulb					Dry Bulb		
cfm	kBtuh	kW	75°F	80°F	85°F	kBtuh	kW	75°F	80°F	85°F	kBtuh	kW	75°F	80°F	85°F	kBtuh	kW	75°F	80°F	85°F	
63°F	1875	82.19	5.34	0.66	0.76	0.88	78	6.08	0.66	0.77	0.89	73.65	6.87	0.66	0.79	0.91	68.81	7.79	0.68	0.8	0.93
	2625	88.63	5.34	0.73	0.87	0.99	84.27	6.07	0.73	0.88	0.99	79.31	6.86	0.73	0.9	0.99	74.76	7.78	0.76	0.92	0.99
	3600	94.76	5.37	0.81	0.98	0.99	90.21	6.1	0.82	0.99	0.99	85.54	6.91	0.84	0.99	0.99	80.6	7.83	0.86	0.99	0.99
67°F	1875	86.66	5.33	0.53	0.63	0.73	82.66	6.05	0.53	0.64	0.74	77.89	6.86	0.53	0.65	0.75	73.27	7.89	0.53	0.65	0.78
	2625	93.86	5.36	0.56	0.7	0.83	89.14	6.09	0.57	0.72	0.85	83.99	6.91	0.57	0.73	0.87	78.66	7.82	0.59	0.73	0.89
	3600	99.42	5.37	0.62	0.78	0.95	94.33	6.11	0.63	0.8	0.97	88.69	6.92	0.63	0.84	0.99	82.85	7.85	0.64	0.86	0.99
71°F	1875	91.16	5.35	0.42	0.52	0.61	86.88	6.07	0.41	0.51	0.61	82.26	6.89	0.4	0.51	0.62	77.4	7.79	0.39	0.52	0.62
	2625	99.01	5.37	0.43	0.56	0.68	93.88	6.11	0.42	0.55	0.69	88.61	6.94	0.42	0.55	0.7	83.14	7.84	0.43	0.56	0.71
	3600	104.73	5.38	0.45	0.61	0.77	99.47	6.14	0.44	0.62	0.78	93.41	6.97	0.44	0.63	0.81	87.55	7.88	0.44	0.64	0.82

NOTE - Compressors operating at maximum capacity.

## 8.5 TON - LGM102U5E/P (LOW COOLING) VARIABLE SPEED COMPRESSOR ONLY OPERATING

Entering Wet Bulb Temperature	Total Air Volume	Outdoor Air Temperature Entering Outdoor Coil																			
		65°F					75°F					85°F					95°F				
		Total Cool Cap.	Comp. Motor Input	Sensible To Total Ratio (S/T)			Total Cool Cap.	Comp. Motor Input	Sensible To Total Ratio (S/T)			Total Cool Cap.	Comp. Motor Input	Sensible To Total Ratio (S/T)			Total Cool Cap.	Comp. Motor Input	Sensible To Total Ratio (S/T)		
				Dry Bulb					Dry Bulb					Dry Bulb					Dry Bulb		
cfm	kBtuh	kW	75°F	80°F	85°F	kBtuh	kW	75°F	80°F	85°F	kBtuh	kW	75°F	80°F	85°F	kBtuh	kW	75°F	80°F	85°F	
63°F	800	52.65	2.79	0.64	0.72	0.8	51.18	3.17	0.64	0.72	0.81	49.75	3.58	0.64	0.73	0.81	47.81	4.02	0.65	0.74	0.82
	1465	64.36	2.71	0.7	0.81	0.93	62.16	3.14	0.71	0.83	0.94	60.16	3.6	0.71	0.85	0.96	57.39	4.08	0.72	0.86	0.98
	2125	70.19	2.66	0.77	0.92	1	67.78	3.12	0.79	0.94	1	64.82	3.6	0.8	0.96	1	62.58	4.1	0.81	0.98	1
67°F	800	55.78	2.77	0.53	0.61	0.68	54.23	3.16	0.53	0.61	0.69	52.47	3.59	0.53	0.61	0.7	50.71	4.04	0.53	0.62	0.7
	1465	68.12	2.68	0.56	0.67	0.78	65.86	3.13	0.56	0.68	0.79	63.67	3.6	0.57	0.69	0.81	61.17	4.09	0.58	0.7	0.82
	2125	74.41	2.62	0.61	0.76	0.89	71.6	3.1	0.62	0.76	0.91	68.5	3.6	0.62	0.77	0.93	65.66	4.11	0.63	0.8	0.95
71°F	800	58.96	2.75	0.43	0.51	0.58	57.12	3.16	0.43	0.51	0.58	55.47	3.59	0.43	0.51	0.58	53.67	4.06	0.43	0.51	0.59
	1465	71.92	2.64	0.43	0.54	0.65	69.52	3.11	0.43	0.54	0.65	66.68	3.6	0.43	0.55	0.67	64.11	4.11	0.44	0.56	0.68
	2125	77.84	2.58	0.45	0.59	0.73	75.19	3.09	0.45	0.6	0.74	72.42	3.6	0.45	0.6	0.75	69.54	4.13	0.46	0.62	0.77

NOTE - Compressor operating at maximum capacity.

## 8.5 TON - LGM102U5E/P (HIGH COOLING) BOTH COMPRESSORS OPERATING

Entering Wet Bulb Temperature	Total Air Volume	Outdoor Air Temperature Entering Outdoor Coil																			
		85°F					95°F					105°F					115°F				
		Total Cool Cap.	Comp. Motor Input	Sensible To Total Ratio (S/T)			Total Cool Cap.	Comp. Motor Input	Sensible To Total Ratio (S/T)			Total Cool Cap.	Comp. Motor Input	Sensible To Total Ratio (S/T)			Total Cool Cap.	Comp. Motor Input	Sensible To Total Ratio (S/T)		
				Dry Bulb					Dry Bulb					Dry Bulb					Dry Bulb		
cfm	kBtuh	kW	75°F	80°F	85°F	kBtuh	kW	75°F	80°F	85°F	kBtuh	kW	75°F	80°F	85°F	kBtuh	kW	75°F	80°F	85°F	
63°F	2125	88.69	5.55	0.68	0.79	0.89	85.01	6.34	0.69	0.8	0.91	81.53	7.2	0.69	0.82	0.93	77.58	8.17	0.72	0.83	0.95
	2975	95.1	5.52	0.74	0.88	0.99	91.44	6.29	0.75	0.91	0.99	87.84	7.17	0.78	0.92	0.99	83.52	8.15	0.78	0.95	0.99
	4080	101.78	5.5	0.84	0.99	0.99	97.98	6.26	0.85	0.99	0.99	94.32	7.12	0.87	0.99	0.99	89.92	8.13	0.89	0.99	0.99
67°F	2125	93.47	5.52	0.54	0.65	0.75	89.89	6.27	0.55	0.66	0.76	86.06	7.16	0.56	0.68	0.78	82.2	8.15	0.55	0.68	0.8
	2975	100.46	5.49	0.58	0.72	0.85	96.6	6.27	0.59	0.74	0.87	92.28	7.15	0.61	0.74	0.89	87.71	8.13	0.62	0.76	0.91
	4080	105.7	5.44	0.63	0.8	0.97	101.26	6.21	0.65	0.82	0.99	96.9	7.13	0.67	0.84	0.99	91.63	8.13	0.67	0.88	0.99
71°F	2125	98.25	5.49	0.43	0.53	0.63	94.45	6.19	0.43	0.54	0.64	90.61	7.16	0.43	0.54	0.65	86.42	8.14	0.43	0.55	0.66
	2975	105.67	5.43	0.44	0.56	0.7	101.46	6.23	0.45	0.57	0.71	97.13	7.12	0.45	0.58	0.73	92.25	8.13	0.46	0.6	0.74
	4080	111.36	5.4	0.46	0.63	0.79	106.69	6.2	0.48	0.65	0.8	101.67	7.09	0.48	0.66	0.82	96.76	8.09	0.48	0.67	0.85

NOTE - Compressors operating at maximum capacity.

# COOLING RATINGS

NOTE – For Temperatures and Capacities not shown in tables, see bulletin – Cooling Unit Rating Table Correction Factor Data in Miscellaneous Engineering Data section.

## 10 TON - LGM120U5E/P (LOW COOLING) VARIABLE SPEED COMPRESSOR ONLY OPERATING

Entering Wet Bulb Temperature	Total Air Volume	Outdoor Air Temperature Entering Outdoor Coil																			
		65°F					75°F					85°F					95°F				
		Total Cool Cap.	Comp. Motor Input	Sensible To Total Ratio (S/T)			Total Cool Cap.	Comp. Motor Input	Sensible To Total Ratio (S/T)			Total Cool Cap.	Comp. Motor Input	Sensible To Total Ratio (S/T)			Total Cool Cap.	Comp. Motor Input	Sensible To Total Ratio (S/T)		
				Dry Bulb					Dry Bulb					Dry Bulb					Dry Bulb		
cfm	kBtuh	kW	75°F	80°F	85°F	kBtuh	kW	75°F	80°F	85°F	kBtuh	kW	75°F	80°F	85°F	kBtuh	kW	75°F	80°F	85°F	
63°F	875	61.7	3.36	0.63	0.71	0.78	59.47	3.81	0.63	0.71	0.79	57.52	4.3	0.64	0.72	0.8	55.57	4.83	0.64	0.72	0.81
	1650	76.05	3.43	0.69	0.8	0.91	73.15	3.91	0.7	0.81	0.92	70.35	4.42	0.7	0.83	0.94	67.43	4.97	0.71	0.84	0.96
	2500	83.5	3.46	0.76	0.92	1	80.26	3.95	0.79	0.93	1	77.03	4.47	0.8	0.95	1	73.56	5.03	0.81	0.97	1
67°F	875	65.19	3.39	0.53	0.6	0.67	63.39	3.85	0.53	0.6	0.68	60.97	4.33	0.53	0.61	0.68	58.76	4.87	0.53	0.61	0.69
	1650	80.31	3.45	0.55	0.66	0.77	77.32	3.93	0.55	0.67	0.78	74.47	4.45	0.56	0.68	0.8	71.32	5.01	0.56	0.69	0.8
	2500	88.16	3.47	0.6	0.74	0.88	84.28	3.96	0.61	0.76	0.9	80.8	4.49	0.62	0.77	0.92	77.41	5.07	0.63	0.79	0.94
71°F	875	68.67	3.41	0.43	0.51	0.57	66.4	3.87	0.43	0.51	0.58	64.45	4.37	0.43	0.51	0.58	62.19	4.91	0.43	0.51	0.58
	1650	84.49	3.46	0.43	0.53	0.64	81.56	3.95	0.43	0.54	0.64	78.05	4.47	0.44	0.54	0.65	75.09	5.05	0.43	0.55	0.67
	2500	92.75	3.47	0.45	0.58	0.72	88.66	3.98	0.45	0.59	0.73	85.16	4.52	0.46	0.6	0.75	81.74	5.11	0.46	0.62	0.77

NOTE - Compressor operating at maximum capacity.

## 10 TON - LGM120U5E/P (HIGH COOLING) BOTH COMRESSORS OPERATING

Entering Wet Bulb Temperature	Total Air Volume	Outdoor Air Temperature Entering Outdoor Coil																			
		85°F					95°F					105°F					115°F				
		Total Cool Cap.	Comp. Motor Input	Sensible To Total Ratio (S/T)			Total Cool Cap.	Comp. Motor Input	Sensible To Total Ratio (S/T)			Total Cool Cap.	Comp. Motor Input	Sensible To Total Ratio (S/T)			Total Cool Cap.	Comp. Motor Input	Sensible To Total Ratio (S/T)		
				Dry Bulb					Dry Bulb					Dry Bulb					Dry Bulb		
cfm	kBtuh	kW	75°F	80°F	85°F	kBtuh	kW	75°F	80°F	85°F	kBtuh	kW	75°F	80°F	85°F	kBtuh	kW	75°F	80°F	85°F	
63°F	2500	109.21	6.97	0.66	0.77	0.88	105.3	7.98	0.68	0.78	0.89	100.42	9.14	0.68	0.8	0.91	95.35	10.43	0.69	0.81	0.93
	3500	117.19	6.98	0.74	0.87	0.96	112.8	7.99	0.74	0.88	0.96	107.58	9.13	0.75	0.9	0.96	102.01	10.43	0.77	0.93	0.96
	4800	124.41	6.96	0.81	0.96	0.96	120.43	7.99	0.83	0.96	0.96	114.88	9.14	0.86	0.96	0.96	110.01	10.47	0.88	0.96	0.96
67°F	2500	114.95	6.96	0.53	0.64	0.74	111.25	7.98	0.54	0.64	0.75	106.31	9.14	0.54	0.66	0.77	101.28	10.43	0.54	0.68	0.78
	3500	123.82	6.96	0.56	0.7	0.84	119.13	7.99	0.57	0.72	0.85	113.47	9.14	0.59	0.74	0.87	107.34	10.45	0.6	0.75	0.9
	4800	130.1	6.95	0.62	0.79	0.95	124.76	7.99	0.64	0.82	0.96	118.68	9.15	0.65	0.84	0.96	112.27	10.48	0.66	0.87	0.96
71°F	2500	121.11	6.95	0.41	0.52	0.61	116.65	7.97	0.42	0.52	0.63	111.66	9.13	0.42	0.53	0.64	106.21	10.42	0.42	0.54	0.65
	3500	130.09	6.94	0.42	0.55	0.68	125.13	7.98	0.42	0.55	0.7	119.35	9.14	0.43	0.57	0.72	113.33	10.48	0.44	0.59	0.72
	4800	137.27	6.93	0.45	0.61	0.77	131.48	7.97	0.45	0.62	0.78	125.17	9.16	0.45	0.65	0.82	118.47	10.49	0.47	0.66	0.85

NOTE - Compressors operating at maximum capacity.

## 12.5 TON - LGM150U5E/P (LOW COOLING) VARIABLE SPEED COMPRESSOR ONLY OPERATING

Entering Wet Bulb Temperature	Total Air Volume	Outdoor Air Temperature Entering Outdoor Coil																			
		65°F					75°F					85°F					95°F				
		Total Cool Cap.	Comp. Motor Input	Sensible To Total Ratio (S/T)			Total Cool Cap.	Comp. Motor Input	Sensible To Total Ratio (S/T)			Total Cool Cap.	Comp. Motor Input	Sensible To Total Ratio (S/T)			Total Cool Cap.	Comp. Motor Input	Sensible To Total Ratio (S/T)		
				Dry Bulb					Dry Bulb					Dry Bulb					Dry Bulb		
cfm	kBtuh	kW	75°F	80°F	85°F	kBtuh	kW	75°F	80°F	85°F	kBtuh	kW	75°F	80°F	85°F	kBtuh	kW	75°F	80°F	85°F	
63°F	1100	67.36	3.41	0.64	0.73	0.82	64.85	3.86	0.65	0.74	0.82	62.4	4.36	0.65	0.75	0.84	60.12	4.9	0.66	0.75	0.85
	1965	79.23	3.46	0.71	0.84	0.97	76.06	3.94	0.73	0.86	0.98	73.13	4.45	0.74	0.87	1	70.19	5.01	0.75	0.89	1
	3125	87.08	3.47	0.83	0.99	1	83.57	3.97	0.85	1	1	80.48	4.5	0.87	1	1	77.71	5.09	0.89	1	1
67°F	1100	70.9	3.43	0.53	0.61	0.7	68.64	3.9	0.54	0.62	0.7	65.65	4.39	0.54	0.63	0.71	63.46	4.94	0.54	0.63	0.72
	1965	83.74	3.47	0.57	0.69	0.81	80.51	3.96	0.58	0.7	0.82	77.05	4.48	0.58	0.72	0.84	73.98	5.05	0.59	0.73	0.86
	3125	91.64	3.48	0.63	0.8	0.97	87.24	3.98	0.65	0.83	0.99	83.54	4.52	0.66	0.84	1	79.97	5.11	0.67	0.87	1
71°F	1100	74.36	3.44	0.43	0.51	0.59	71.79	3.91	0.43	0.51	0.59	69.43	4.42	0.43	0.51	0.6	67.02	4.98	0.43	0.52	0.61
	1965	88.15	3.47	0.43	0.55	0.67	84.4	3.97	0.44	0.56	0.68	81.07	4.51	0.44	0.57	0.69	78.02	5.09	0.44	0.57	0.71
	3125	95.96	3.47	0.46	0.62	0.78	91.98	3.99	0.46	0.64	0.81	88.39	4.56	0.47	0.65	0.83	84.59	5.16	0.48	0.66	0.84

NOTE - Compressor operating at maximum capacity.

## 12.5 TON - LGM150U5E/P (HIGH COOLING) BOTH COMRESSORS OPERATING

Entering Wet Bulb Temperature	Total Air Volume	Outdoor Air Temperature Entering Outdoor Coil																			
		85°F					95°F					105°F					115°F				
		Total Cool Cap.	Comp. Motor Input	Sensible To Total Ratio (S/T)			Total Cool Cap.	Comp. Motor Input	Sensible To Total Ratio (S/T)			Total Cool Cap.	Comp. Motor Input	Sensible To Total Ratio (S/T)			Total Cool Cap.	Comp. Motor Input	Sensible To Total Ratio (S/T)		
				Dry Bulb					Dry Bulb					Dry Bulb					Dry Bulb		
cfm	kBtuh	kW	75°F	80°F	85°F	kBtuh	kW	75°F	80°F	85°F	kBtuh	kW	75°F	80°F	85°F	kBtuh	kW	75°F	80°F	85°F	
63°F	3125	131.54	9.28	0.65	0.76	0.86	126.1	10.49	0.66	0.77	0.88	120.71	11.85	0.66	0.78	0.9	114.94	13.38	0.68	0.8	0.92
	4375	140.6	9.33	0.71	0.85	0.93	134.39	10.56	0.73	0.88	0.93	128.37	11.93	0.74	0.89	0.93	122.12	13.45	0.76	0.91	0.93
	6000	148.76	9.38	0.8	0.93	0.93	143.42	10.64	0.82	0.93	0.93	137.42	12.03	0.85	0.93	0.93	131.31	13.57	0.87	0.93	0.93
67°F	3125	138.86	9.33	0.52	0.63	0.72	132.59	10.56	0.52	0.64	0.74	127.61	11.93	0.52	0.65	0.75	121.13	13.46	0.53	0.65	0.77
	4375	148	9.38	0.56	0.69	0.82	142.08	10.62	0.57	0.72	0.84	135.7	12	0.58	0.73	0.86	129.18	13.54	0.59	0.73	0.89
	6000	155.85	9.4	0.61	0.77	0.93	148.97	10.67	0.61	0.8	0.93	142.25	12.07	0.65	0.82	0.93	135.09	13.61	0.66	0.85	0.93
71°F	3125	144.67	9.36	0.41	0.51	0.6	139.59	10.61	0.4	0.52	0.61	133.92	11.99	0.4	0.51	0.62	127.91	13.53	0.41	0.52	0.63
	4375	155.47	9.41	0.42	0.55	0.67	149.68	10.67	0.42	0.55	0.68	143.09	12.08	0.43	0.56	0.7	135.87	13.63	0.43	0.57	0.72
	6000	163.82	9.44	0.44	0.6	0.75	157.33	10.73	0.44	0.6	0.78	149.82	12.14	0.45	0.64	0.8	142.52	13.7	0.46	0.65	0.83

NOTE - Compressors operating at maximum capacity.

# HUMIDITROL® DEHUMIDIFICATION SYSTEM RATINGS

## 7.5 TON - LGM092U5E/P WITH HUMIDITROL® OPERATING

Entering Wet Bulb Temperature	Total Air Volume	Outdoor Air Temperature Entering Outdoor Coil																			
		65°F					75°F					85°F					95°F				
		Total Cool Cap.	Comp. Motor Input	Sensible To Total Ratio (S/T)			Total Cool Cap.	Comp. Motor Input	Sensible To Total Ratio (S/T)			Total Cool Cap.	Comp. Motor Input	Sensible To Total Ratio (S/T)			Total Cool Cap.	Comp. Motor Input	Sensible To Total Ratio (S/T)		
				Dry Bulb					Dry Bulb					Dry Bulb					Dry Bulb		
cfm	kBtuh	kW	75°F	80°F	85°F	kBtuh	kW	75°F	80°F	85°F	kBtuh	kW	75°F	80°F	85°F	kBtuh	kW	75°F	80°F	85°F	
63°F	1125	26.9	2.6	0.38	0.59	0.78	20.8	2.9	0.24	0.53	0.75	17.5	3.1	0.14	0.50	0.74	13.7	3.2	0.01	0.40	0.68
	1500	29.5	2.6	0.44	0.65	0.84	23.5	2.9	0.31	0.58	0.81	18.9	3.0	0.20	0.53	0.80	14.1	3.2	0.07	0.44	0.75
	1875	32.2	2.6	0.50	0.70	0.89	26.3	2.8	0.38	0.63	0.87	20.4	3.0	0.26	0.55	0.85	14.5	3.2	0.13	0.48	0.83
67°F	1125	30.9	2.7	0.18	0.37	0.55	26.6	2.9	0.08	0.30	0.52	25.2	2.9	0.08	0.31	0.53	18.1	3.2	-0.17	0.13	0.46
	1500	33.1	2.7	0.21	0.43	0.65	28.0	2.9	0.08	0.35	0.63	24.3	2.9	-0.01	0.31	0.63	17.7	3.2	-0.21	0.18	0.59
	1875	35.3	2.6	0.24	0.49	0.75	29.3	2.8	0.07	0.41	0.74	23.4	3.0	-0.09	0.32	0.73	17.4	3.2	-0.26	0.23	0.72
71°F	1125	36.9	2.7	0.04	0.21	0.36	36.6	2.7	0.05	0.21	0.37	31.5	2.9	-0.03	0.15	0.33	24.0	3.2	-0.26	-0.03	0.20
	1500	40.6	2.6	0.07	0.26	0.43	37.1	2.7	-0.01	0.21	0.42	31.2	2.9	-0.12	0.13	0.37	24.2	3.2	-0.31	-0.01	0.29
	1875	44.2	2.6	0.09	0.30	0.51	37.6	2.8	-0.06	0.20	0.47	31.0	3.0	-0.22	0.10	0.42	24.4	3.2	-0.37	0.00	0.37

NOTE - Total Cooling Capacity is calculated at 80°F Dry Bulb.

## 8.5 TON - LGM102U5E/P WITH HUMIDITROL® OPERATING

Entering Wet Bulb Temperature	Total Air Volume	Outdoor Air Temperature Entering Outdoor Coil																			
		65°F					75°F					85°F					95°F				
		Total Cool Cap.	Comp. Motor Input	Sensible To Total Ratio (S/T)			Total Cool Cap.	Comp. Motor Input	Sensible To Total Ratio (S/T)			Total Cool Cap.	Comp. Motor Input	Sensible To Total Ratio (S/T)			Total Cool Cap.	Comp. Motor Input	Sensible To Total Ratio (S/T)		
				Dry Bulb					Dry Bulb					Dry Bulb					Dry Bulb		
cfm	kBtuh	kW	75°F	80°F	85°F	kBtuh	kW	75°F	80°F	85°F	kBtuh	kW	75°F	80°F	85°F	kBtuh	kW	75°F	80°F	85°F	
63°F	1275	27.2	2.6	0.39	0.63	0.85	20.6	2.9	0.27	0.57	0.82	18.2	3.0	0.14	0.57	0.79	13.8	3.2	0.04	0.47	0.74
	1700	30.6	2.6	0.47	0.67	0.85	24.1	2.9	0.36	0.60	0.82	19.7	3.0	0.24	0.57	0.80	14.3	3.2	0.13	0.48	0.76
	2125	34.0	2.6	0.55	0.70	0.85	27.6	2.8	0.44	0.64	0.83	21.2	3.0	0.33	0.57	0.80	14.9	3.2	0.23	0.50	0.78
67°F	1275	32.9	2.7	0.18	0.38	0.59	28.6	2.8	0.08	0.33	0.56	26.7	2.8	0.08	0.34	0.58	18.9	3.2	-0.17	0.16	0.51
	1700	35.0	2.6	0.22	0.45	0.69	29.7	2.8	0.09	0.38	0.67	25.6	2.9	0.01	0.35	0.68	18.6	3.2	-0.19	0.22	0.64
	2125	37.0	2.6	0.25	0.52	0.79	30.8	2.8	0.10	0.44	0.78	24.6	3.0	-0.06	0.36	0.77	18.4	3.2	-0.21	0.28	0.77
71°F	1275	39.7	2.7	0.06	0.23	0.40	39.3	2.6	0.06	0.23	0.40	33.4	2.8	-0.03	0.17	0.36	25.7	3.2	-0.27	-0.02	0.23
	1700	42.4	2.6	0.07	0.28	0.48	38.8	2.7	-0.01	0.23	0.46	32.4	2.9	-0.13	0.14	0.41	25.1	3.2	-0.34	-0.01	0.32
	2125	45.1	2.6	0.09	0.33	0.57	38.2	2.8	-0.08	0.22	0.52	31.3	3.0	-0.24	0.11	0.46	24.5	3.2	-0.40	0.01	0.41

NOTE - Total Cooling Capacity is calculated at 80°F Dry Bulb.

## 10 TON - LGM120U5E/P WITH HUMIDITROL® OPERATING

Entering Wet Bulb Temperature	Total Air Volume	Outdoor Air Temperature Entering Outdoor Coil																			
		65°F					75°F					85°F					95°F				
		Total Cool Cap.	Comp. Motor Input	Sensible To Total Ratio (S/T)			Total Cool Cap.	Comp. Motor Input	Sensible To Total Ratio (S/T)			Total Cool Cap.	Comp. Motor Input	Sensible To Total Ratio (S/T)			Total Cool Cap.	Comp. Motor Input	Sensible To Total Ratio (S/T)		
				Dry Bulb					Dry Bulb					Dry Bulb					Dry Bulb		
cfm	kBtuh	kW	75°F	80°F	85°F	kBtuh	kW	75°F	80°F	85°F	kBtuh	kW	75°F	80°F	85°F	kBtuh	kW	75°F	80°F	85°F	
63°F	1500	36.1	3.3	0.38	0.59	0.78	28.6	3.7	0.26	0.53	0.73	25.3	3.8	0.16	0.48	0.73	21.7	3.9	0.12	0.45	0.67
	2000	39.0	3.4	0.45	0.63	0.79	31.8	3.6	0.35	0.57	0.75	26.8	3.8	0.26	0.51	0.73	21.6	3.9	0.20	0.46	0.68
	2500	41.9	3.4	0.52	0.66	0.81	35.0	3.6	0.43	0.60	0.77	28.2	3.8	0.35	0.54	0.73	21.4	3.9	0.27	0.48	0.69
67°F	1500	41.0	3.4	0.18	0.37	0.56	35.2	3.7	0.08	0.31	0.52	35.1	3.6	0.09	0.32	0.54	27.1	4.0	-0.09	0.20	0.46
	2000	42.8	3.4	0.21	0.43	0.65	36.6	3.7	0.09	0.36	0.62	33.2	3.7	0.03	0.33	0.62	25.9	4.0	-0.12	0.24	0.58
	2500	44.6	3.5	0.23	0.49	0.74	37.9	3.6	0.11	0.41	0.72	31.3	3.8	-0.02	0.34	0.71	24.7	4.0	-0.15	0.27	0.69
71°F	1500	48.8	3.4	0.03	0.22	0.35	48.5	3.4	0.07	0.22	0.39	42.0	3.6	-0.02	0.17	0.35	33.6	4.0	-0.21	0.02	0.24
	2000	52.2	3.4	0.05	0.26	0.44	47.9	3.4	0.01	0.22	0.43	40.5	3.7	-0.10	0.15	0.39	32.2	4.0	-0.26	0.03	0.31
	2500	55.7	3.3	0.07	0.30	0.53	47.4	3.5	-0.05	0.21	0.48	39.1	3.8	-0.18	0.13	0.43	30.8	4.0	-0.31	0.04	0.39

NOTE - Total Cooling Capacity is calculated at 80°F Dry Bulb.

## 12.5 TON - LGM150U5E/P WITH HUMIDITROL® OPERATING

Entering Wet Bulb Temperature	Total Air Volume	Outdoor Air Temperature Entering Outdoor Coil																			
		65°F					75°F					85°F					95°F				
		Total Cool Cap.	Comp. Motor Input	Sensible To Total Ratio (S/T)			Total Cool Cap.	Comp. Motor Input	Sensible To Total Ratio (S/T)			Total Cool Cap.	Comp. Motor Input	Sensible To Total Ratio (S/T)			Total Cool Cap.	Comp. Motor Input	Sensible To Total Ratio (S/T)		
				Dry Bulb					Dry Bulb					Dry Bulb					Dry Bulb		
cfm	kBtuh	kW	75°F	80°F	85°F	kBtuh	kW	75°F	80°F	85°F	kBtuh	kW	75°F	80°F	85°F	kBtuh	kW	75°F	80°F	85°F	
63°F	1875	31.8	3.4	0.41	0.75	1.00	25.0	3.6	0.28	0.67	1.00	22.6	3.7	0.22	0.70	1.00	15.7	3.9	0.11	0.62	1.00
	2500	32.5	3.3	0.53	0.79	1.00	25.6	3.6	0.41	0.72	1.00	20.9	3.7	0.33	0.71	1.00	13.9	3.9	0.22	0.64	1.00
	3125	33.3	3.3	0.65	0.82	1.00	26.3	3.5	0.54	0.77	1.00	19.2	3.7	0.44	0.72	1.00	12.2	3.9	0.33	0.67	1.00
67°F	1875	38.8	3.5	0.17	0.41	0.64	36.6	3.5	0.12	0.40	0.64	34.5	3.5	0.12	0.42	0.65	23.8	4.0	-0.14	0.24	0.60
	2500	41.8	3.4	0.22	0.48	0.74	36.0	3.5	0.10	0.43	0.72	30.3	3.6	0.02	0.38	0.71	20.2	3.9	-0.20	0.24	0.67
	3125	44.8	3.3	0.27	0.55	0.84	35.4	3.5	0.09	0.45	0.81	26.1	3.7	-0.08	0.35	0.78	16.7	3.9	-0.25	0.25	0.75
71°F	1875	51.5	3.3	0.07	0.28	0.45	49.4	3.2	0.07	0.29	0.47	40.3	3.5	-0.05	0.19	0.42	30.9	4.0	-0.29	0.01	0.31
	2500	53.3	3.2	0.09	0.33	0.54	47.7	3.3	-0.02	0.26	0.52	38.7	3.6	-0.17	0.15	0.47	29.5	4.0	-0.40	-0.01	0.39
	3125	55.1	3.2	0.11	0.37	0.63	46.1	3.5	-0.10	0.24	0.58	37.1	3.7	-0.30	0.11	0.52	28.1	4.0	-0.51	-0.02	0.47

NOTE - Total Cooling Capacity is calculated at 80°F Dry Bulb.

## BLOWER DATA

**BLOWER TABLE INCLUDES RESISTANCE FOR BASE UNIT ONLY (NO HEAT SECTION) WITH DRY INDOOR COIL AND AIR FILTERS IN PLACE.**

FOR ALL UNITS ADD:

- 1 – Wet indoor coil air resistance of selected unit.
  - 2 – Any factory installed options air resistance (heat section, Economizer, etc.)
  - 3 – Any field installed accessories air resistance (duct resistance, diffuser, etc.)
- See page 28 for wet coil and option/accessory air resistance data.

**Maximum Static Pressure With Gas Heat - 2.0 in. w.g.**

**Minimum Air Volume Required For Different Gas Heat Sizes:**

Standard - 2150 cfm; Medium - 2250 cfm; High - 2600 cfm

Total Air Volume cfm	Total Static Pressure - in. w.g.													
	0.2		0.4		0.6		0.8		1.0		1.2		1.4	
	RPM	Watts	RPM	Watts	RPM	Watts	RPM	Watts	RPM	Watts	RPM	Watts	RPM	Watts
1750	644	137	740	235	796	302	833	343	873	373	996	558	1065	664
2000	675	165	768	260	821	330	861	386	960	507	1026	629	1094	753
2250	711	195	803	290	856	375	901	497	991	564	1058	703	1128	840
2500	764	241	852	335	904	439	951	568	1025	641	1097	789	1170	934
2750	847	316	901	399	946	543	1004	674	1074	746	1146	895	1220	1041
3000	944	426	980	511	1021	671	1074	803	1136	874	1205	1021	1276	1167
3250	1022	544	1057	640	1099	810	1149	942	1207	1012	1272	1156	1338	1304
3500	1092	666	1131	770	1174	948	1225	1081	1281	1151	1342	1297	1402	1451
3750	1161	780	1202	892	1248	1079	1298	1217	1353	1291	1409	1445	1463	1609
4000	1230	888	1273	1010	1319	1212	1369	1362	1421	1441	1471	1608	1518	1784
4250	1299	1006	1342	1140	1388	1362	1436	1526	1483	1612	1528	1790	1571	1975
4500	1366	1142	1409	1289	1454	1532	1498	1708	1542	1798	1583	1984	1623	2172
4750	1432	1295	1474	1457	1516	1719	1558	1903	1598	1997	1637	2187	1674	2377
5000	1496	1471	1537	1645	1577	1921	1616	2110	1654	2205	1690	2396	1726	2586
5250	1560	1667	1598	1849	1636	2132	1673	2324	1709	2419	1744	2609	1779	2796
5500	1623	1878	1659	2064	1695	2349	1731	2539	1765	2634	---	---	---	---
5750	1686	2097	1720	2284	1755	2567	---	---	---	---	---	---	---	---
6000	1748	2316	1781	2502	---	---	---	---	---	---	---	---	---	---

Total Air Volume cfm	Total Static Pressure - in. w.g.											
	1.6		1.8		2.0		2.2		2.4		2.6	
	RPM	Watts	RPM	Watts	RPM	Watts	RPM	Watts	RPM	Watts	RPM	Watts
1750	1134	775	1203	896	1275	1025	1356	1149	1422	1287	1470	1439
2000	1162	878	1231	1007	1302	1139	1379	1268	1440	1411	1486	1570
2250	1198	975	1268	1111	1338	1250	1409	1388	1464	1542	1507	1711
2500	1243	1075	1313	1217	1380	1365	1442	1517	1491	1685	1533	1860
2750	1293	1186	1361	1336	1423	1494	1477	1661	1520	1839	1561	2016
3000	1346	1317	1410	1474	1466	1642	1514	1818	1554	2000	1594	2180
3250	1402	1460	1460	1627	1511	1803	1553	1986	1591	2172	1631	2352
3500	1459	1616	1509	1793	1555	1976	1594	2165	1631	2352	1671	2531
3750	1512	1785	1557	1970	1599	2159	1636	2350	1673	2536	1713	2714
4000	1562	1969	1604	2157	1643	2347	1680	2538	1717	2722	1756	2896
4250	1611	2163	1650	2352	1688	2541	1724	2729	1762	2908	---	---
4500	1661	2362	1698	2552	1734	2739	1770	2922	---	---	---	---
4750	1710	2567	1746	2754	---	---	---	---	---	---	---	---
5000	1761	2774	---	---	---	---	---	---	---	---	---	---

## BLOWER DATA

### POWER EXHAUST FAN PERFORMANCE

Return Air System Static Pressure	Air Volume Exhausted
in. w.g.	cfm
0	3175
0.05	2955
0.10	2685
0.15	2410
0.20	2165
0.25	1920
0.30	1420
0.35	1200

### FACTORY INSTALLED OPTIONS/FIELD INSTALLED ACCESSORY AIR RESISTANCE - in. w.g.

Air Volume cfm	Wet Indoor Coil		Gas Heat Exchanger			Economizer	Humiditrol® + Reheat Coil	Filters			Return Air Adaptor Plate
			Standard Heat	Medium Heat	High Heat			MERV 8	MERV 13	MERV 16	
	092, 102	120, 150									
1750	0.04	0.04	0.06	0.02	0.02	0.05	0.02	0.01	0.03	0.06	0.00
2000	0.05	0.05	0.07	0.05	0.06	0.06	0.02	0.01	0.03	0.08	0.00
2250	0.06	0.06	0.07	0.07	0.08	0.08	0.02	0.01	0.04	0.09	0.00
2500	0.07	0.07	0.09	0.10	0.11	0.11	0.03	0.01	0.05	0.10	0.00
2750	0.08	0.08	0.09	0.11	0.12	0.12	0.03	0.02	0.05	0.11	0.00
3000	0.10	0.09	0.11	0.12	0.13	0.13	0.03	0.02	0.06	0.12	0.02
3250	0.11	0.10	0.12	0.15	0.16	0.15	0.04	0.02	0.06	0.13	0.02
3500	0.12	0.11	0.12	0.16	0.17	0.15	0.04	0.03	0.07	0.15	0.04
3750	0.14	0.13	0.14	0.19	0.20	0.15	0.05	0.03	0.08	0.16	0.07
4000	0.15	0.14	0.14	0.21	0.22	0.19	0.05	0.04	0.08	0.17	0.09
4250	0.17	0.15	0.14	0.24	0.28	0.19	0.06	0.04	0.09	0.19	0.11
4500	0.19	0.17	0.15	0.26	0.32	0.22	0.07	0.04	0.09	0.20	0.12
4750	0.20	0.18	0.16	0.29	0.37	0.25	0.07	0.05	0.10	0.21	0.16
5000	0.22	0.20	0.16	0.34	0.43	0.29	0.08	0.06	0.10	0.23	0.18
5250	0.24	0.22	0.16	0.37	0.47	0.32	0.08	0.06	0.11	0.24	0.19
5500	0.25	0.23	0.18	0.44	0.54	0.34	0.09	0.07	0.12	0.25	0.22
5750	0.27	0.25	0.19	0.49	0.59	0.45	0.10	0.07	0.12	0.27	0.25
6000	0.29	0.27	0.20	0.54	0.64	0.52	0.10	0.08	0.13	0.28	0.27

## BLOWER DATA

### CEILING DIFFUSERS AIR RESISTANCE - in. w.g.

Size	RTD11 Step-Down Diffuser			FD11 Flush Diffuser	
	Air Volume cfm	2 Ends Open	1 Side, 2 Ends Open		All Ends & Sides Open
092	2400	0.21	0.18	0.15	0.14
	2600	0.24	0.21	0.18	0.17
	2800	0.27	0.24	0.21	0.20
	3000	0.32	0.29	0.25	0.25
	3200	0.41	0.37	0.32	0.31
	3400	0.50	0.45	0.39	0.37
	3600	0.61	0.54	0.48	0.44
	3800	0.73	0.63	0.57	0.51
102 & 120	3600	0.36	0.28	0.23	0.15
	3800	0.40	0.32	0.26	0.18
	4000	0.44	0.36	0.29	0.21
	4200	0.49	0.40	0.33	0.24
	4400	0.54	0.44	0.37	0.27
	4600	0.60	0.49	0.42	0.31
	4800	0.65	0.53	0.46	0.35
	5000	0.69	0.58	0.50	0.39
150	5200	0.75	0.62	0.54	0.43
	4200	0.22	0.19	0.16	0.10
	4400	0.28	0.24	0.20	0.12
	4600	0.34	0.29	0.24	0.15
	4800	0.40	0.34	0.29	0.19
	5000	0.46	0.39	0.34	0.23
	5200	0.52	0.44	0.39	0.27
	5400	0.58	0.49	0.43	0.31
5600	0.64	0.54	0.47	0.35	
5800	0.70	0.59	0.51	0.39	

### CEILING DIFFUSER AIR THROW DATA

Model	Air Volume	<sup>1</sup> Effective Throw Range	
		RTD11 Step-Down	FD11 Flush
	cfm	ft.	ft.
092	2600	24 - 29	19 - 24
	2800	25 - 30	20 - 28
	3000	27 - 33	21 - 29
	3200	28 - 35	22 - 29
	3400	30 - 37	22 - 30
102, 120	3600	25 - 33	22 - 29
	3800	27 - 35	22 - 30
	4000	29 - 37	24 - 33
	4200	32 - 40	26 - 35
	4400	34 - 42	28 - 37
150	5600	39 - 49	28 - 37
	5800	42 - 51	29 - 38
	6000	44 - 54	40 - 50
	6200	45 - 55	42 - 51
	6400	46 - 55	43 - 52
6600	47 - 56	45 - 56	

<sup>1</sup> Throw is the horizontal or vertical distance an air stream travels on leaving the outlet or diffuser before the maximum velocity is reduced to 50 ft. per minute. Four sides open.

**ELECTRICAL DATA** **7.5 TON**

<b>Model</b>		<b>LGM092U5E/ LGM092U5P</b>		
<b><sup>1</sup> Voltage - 60Hz</b>		<b>208/230V-3ph</b>	<b>460V-3ph</b>	<b>575V-3ph</b>
Compressor 1 (Inverter)	Rated Load Amps	10.6	6.1	5.6
	Locked Rotor Amps	17	11.5	12
Compressor 2 (Non-Inverter)	Rated Load Amps	12.8	6	5.8
	Locked Rotor Amps	120.4	49.4	41
Outdoor Fan Motors (2)	Full Load Amps (2 ECM)	2.8	1.4	1.1
	Total	5.6	2.8	2.2
Power Exhaust (1) 0.33 HP	Full Load Amps	2.4	1.3	1
Service Outlet 115V GFI (amps)		15	15	20
Indoor Blower Motor	Horsepower	3.75	3.75	3.75
	Full Load Amps	8	4.2	3.6
<sup>2</sup> Maximum Overcurrent Protection (MOCP)	Unit Only	50	25	20
	With (1) 0.33 HP Power Exhaust	50	25	25
<sup>3</sup> Minimum Circuit Ampacity (MCA)	Unit Only	41	21	19
	With (1) 0.33 HP Power Exhaust	43	22	20

NOTE - All units have a minimum Short Circuit Current Rating (SCCR) of 5000 amps.

<sup>1</sup> 1 Extremes of operating range are plus and minus 10% of line voltage.

<sup>2</sup> 2 HACR type breaker or fuse.

<sup>3</sup> 3 Refer to National or Canadian Electrical Code manual to determine wire, fuse and disconnect size requirements.

**ELECTRICAL DATA** **8.5 TON**

<b>Model</b>		<b>LGM102U5E/ LGM102U5P</b>		
<b><sup>1</sup> Voltage - 60Hz</b>		<b>208/230V-3ph</b>	<b>460V-3ph</b>	<b>575V-3ph</b>
Compressor 1 (Inverter)	Rated Load Amps	10.6	6.1	5.6
	Locked Rotor Amps	17	11.5	12
Compressor 2 (Non-Inverter)	Rated Load Amps	12.8	6	5.8
	Locked Rotor Amps	120.4	49.4	41
Outdoor Fan Motors (2)	Full Load Amps (2 ECM)	2.8	1.4	1.1
	Total	5.6	2.8	2.2
Power Exhaust (1) 0.33 HP	Full Load Amps	2.4	1.3	1
Service Outlet 115V GFI (amps)		15	15	20
Indoor Blower Motor	Horsepower	3.75	3.75	3.75
	Full Load Amps	8	4.2	3.6
<sup>2</sup> Maximum Overcurrent Protection (MOCP)	Unit Only	50	25	20
	With (1) 0.33 HP Power Exhaust	50	25	25
<sup>3</sup> Minimum Circuit Ampacity (MCA)	Unit Only	41	21	19
	With (1) 0.33 HP Power Exhaust	43	22	20

NOTE - All units have a minimum Short Circuit Current Rating (SCCR) of 5000 amps.

<sup>1</sup> 1 Extremes of operating range are plus and minus 10% of line voltage.

<sup>2</sup> 2 HACR type breaker or fuse.

<sup>3</sup> 3 Refer to National or Canadian Electrical Code manual to determine wire, fuse and disconnect size requirements.

**ELECTRICAL DATA****10 TON**

Model		LGM120U5E/ LGM120U5P		
<sup>1</sup> Voltage - 60Hz		208/230V-3ph	460V-3ph	575V-3ph
Compressor 1 (Inverter)	Rated Load Amps	13.7	7.5	6.7
	Locked Rotor Amps	21	12	12
Compressor 2 (Non-Inverter)	Rated Load Amps	16	7.1	6.4
	Locked Rotor Amps	156.4	69	47.8
Outdoor Fan Motors (2)	Full Load Amps (2 ECM)	2.8	1.4	1.1
	Total	5.6	2.8	2.2
Power Exhaust (1) 0.33 HP	Full Load Amps	2.4	1.3	1
Service Outlet 115V GFI (amps)		15	15	20
Indoor Blower Motor	Horsepower	3.75	3.75	3.75
	Full Load Amps	8	4.2	3.6
<sup>2</sup> Maximum Overcurrent Protection (MOCP)	Unit Only	60	30	25
	With (1) 0.33 HP Power Exhaust	60	30	25
<sup>3</sup> Minimum Circuit Ampacity (MCA)	Unit Only	48	24	21
	With (1) 0.33 HP Power Exhaust	50	25	22

NOTE - All units have a minimum Short Circuit Current Rating (SCCR) of 5000 amps.

<sup>1</sup> 1 Extremes of operating range are plus and minus 10% of line voltage.<sup>2</sup> 2 HACR type breaker or fuse.<sup>3</sup> 3 Refer to National or Canadian Electrical Code manual to determine wire, fuse and disconnect size requirements.**ELECTRICAL DATA****12.5 TON**

Model		LGM150U5E/ LGM150U5P		
<sup>1</sup> Voltage - 60Hz		208/230V-3ph	460V-3ph	575V-3ph
Compressor 1	Rated Load Amps	13.7	7.5	6.7
	Locked Rotor Amps	21	12	12
Compressor 2	Rated Load Amps	22.4	9.1	7.2
	Locked Rotor Amps	166.2	74.6	54
Outdoor Fan Motors (2)	Full Load Amps (2 ECM)	2.8	1.4	1.1
	Total	5.6	2.8	2.2
Power Exhaust (1) 0.33 HP	Full Load Amps	2.4	1.3	1
Service Outlet 115V GFI (amps)		15	15	20
Indoor Blower Motor	Horsepower	3.75	3.75	3.75
	Full Load Amps	8	4.2	3.6
<sup>2</sup> Maximum Overcurrent Protection (MOCP)	Unit Only	70	30	25
	With (1) 0.33 HP Power Exhaust	80	35	25
<sup>3</sup> Minimum Circuit Ampacity (MCA)	Unit Only	56	26	22
	With (1) 0.33 HP Power Exhaust	58	28	23

NOTE - All units have a minimum Short Circuit Current Rating (SCCR) of 5000 amps.

<sup>1</sup> 1 Extremes of operating range are plus and minus 10% of line voltage.<sup>2</sup> 2 HACR type breaker or fuse.<sup>3</sup> 3 Refer to National or Canadian Electrical Code manual to determine wire, fuse and disconnect size requirements.**FIELD WIRING NOTES**

- For use with copper wiring only
- Field wiring not furnished
- All wiring must conform to NEC or CEC and local electrical codes
- For specific wiring information, please refer to the installation instructions

## UNIT CLEARANCES

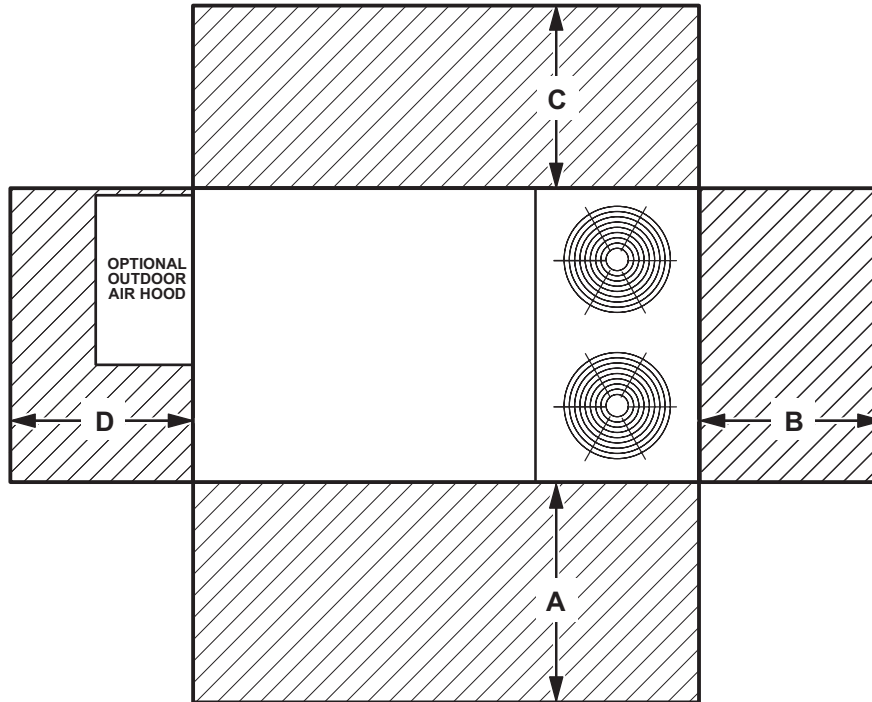

<sup>1</sup> Unit Clearance	A		B		C		D		Top Clearance
	in.	mm	in.	mm	in.	mm	in.	mm	
<b>Service Clearance</b>	60	1524	36	914	36	934	60	1524	Unobstructed
<b>Clearance to Combustibles</b>	36	914	1	25	1	25	1	25	
<b>Minimum Operation Clearance</b>	36	914	36	914	36	914	36	914	

NOTE - Entire perimeter of unit base requires support when elevated above the mounting surface.

<sup>1</sup> Service Clearance - Required for removal of serviceable parts.

Clearance to Combustibles - Required clearance to combustible material.

Minimum Operation Clearance - Required clearance for proper unit operation.

## OUTDOOR SOUND DATA

Size	Octave Band Sound Power Levels dBA, re 10 <sup>-12</sup> Watts - Center Frequency - Hz							<sup>1</sup> Sound Rating Number (dBA)
	125	250	500	1000	2000	4000	8000	
092-102 Min.	58	62	62	60	55	47	60	68
092-102 Max.	72	77	81	79	74	68	66	85
120-150 Min.	55	60	62	60	56	48	60	67
120-150 Max.	79	78	85	83	79	76	73	89

Note - The octave sound power data does not include tonal corrections.

<sup>1</sup> Sound Rating Number according to AHRI Standard 370-2001 (includes pure tone penalty).

Sound Rating Number is the overall A-Weighted Sound Power Level (L<sub>WA</sub>), dBA (100 Hz to 10,000 Hz).

WEIGHT DATA				UNIT
Size	Net		Shipping	
	lbs.	kg	lbs.	kg
092 Base Unit	1115	506	1200	544
092 Max. Unit	1259	571	1344	610
102 Base Unit	1115	506	1200	544
102 Max. Unit	1266	574	1351	613
120 Base Unit	1150	522	1235	560
120 Max. Unit	1301	590	1386	629
150 Base Unit	1170	531	1255	569
150 Max. Unit	1321	599	1406	638

FACTORY / FIELD INSTALLED OPTIONS AND ACCESSORIES - NET WEIGHTS			
Description		lbs.	kg
<b>ECONOMIZER / OUTDOOR AIR / EXHAUST</b>			
<b>Economizer</b>			
Economizer Dampers		56	26
Outdoor Air Hood (downflow)		21	10
Barometric Relief Dampers (downflow)		9	4
Barometric Relief Dampers (low profile horizontal)		20	9
<b>Outdoor Air Dampers</b>			
Automatic		10	5
Manual		10	5
<b>Power Exhaust</b>		31	14
<b>GAS HEAT EXCHANGER (NET WEIGHT)</b>			
Medium Heat (adder over standard heat)		17	8
High Heat (adder over standard heat)		33	15
<b>COIL/HAIL GUARDS</b>			
All Models		21	10
<b>ROOF CURBS</b>			
<b>Hybrid Roof Curbs, Downflow</b>			
8 in. height		103	47
14 in. height		125	57
18 in. height		147	67
24 in. height		169	77
<b>Adjustable Pitch Curb, Downflow</b>			
14 in. height		169	77
<b>CEILING DIFFUSERS</b>			
<b>Step-Down</b>			
	RTD11-95S	118	54
	RTD11-135S	135	61
	RTD11-185S	168	76
<b>Flush</b>			
	FD11-95S	118	54
	FD11-135S	135	61
	FD11-185S	168	76
<b>Transitions</b>			
	C1DIFF30B-1	30	14
	C1DIFF31B-1	32	15
	C1DIFF32B-1	36	16
<b>HUMIDITROL®+ HOT GAS REHEAT SYSTEM</b>			
	Humiditrol®+ Dehumidification Option	20	9

# DIMENSIONS

# UNIT

Size	CORNER WEIGHTS																CENTER OF GRAVITY							
	AA				BB				CC				DD				EE				FF			
	Base		Max.		Base		Max.		Base		Max.		Base		Max.		Base		Max.		Base		Max.	
	lbs.	kg	lbs.	kg	lbs.	kg	lbs.	kg	lbs.	kg	lbs.	kg	lbs.	kg	lbs.	kg	in.	mm	in.	mm	in.	mm	in.	mm
092	293	133	338	153	263	119	295	134	286	130	316	143	326	148	370	168	46.5	1181	45.5	1156	24.5	622	25.5	648
102	294	134	340	154	265	120	297	135	288	131	318	144	328	149	372	169	46.5	1181	45.5	1156	24.5	622	25.5	648
120	306	139	349	158	275	125	305	138	295	134	326	148	334	152	382	173	46.5	1181	45.5	1156	24.5	622	25.5	648
150	316	143	359	163	284	129	314	142	304	138	393	178	345	157	393	178	46.5	1181	45.5	1156	24.5	622	25.5	648

Base Unit - The unit with NO INTERNAL OPTIONS.

Max. Unit - The unit with ALL INTERNAL OPTIONS Installed. (Economizer, Standard Static Power Exhaust Fans, Controls, etc.). Does not include accessories external to unit or high static power exhaust.

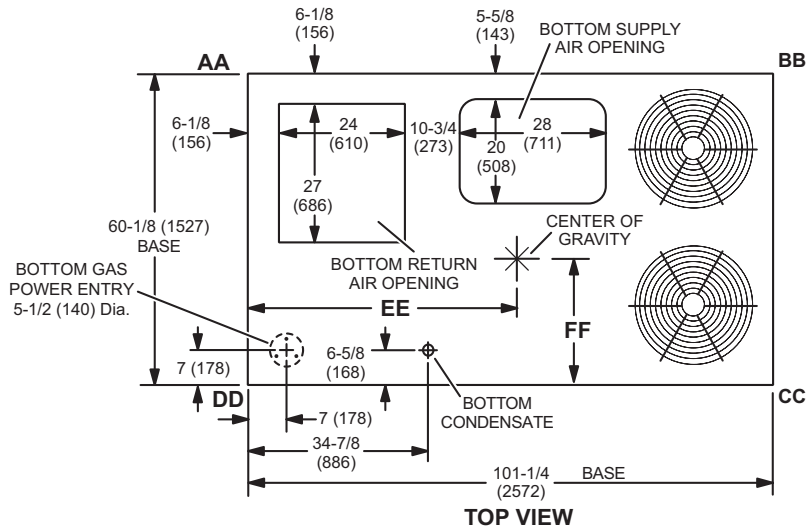

**TOP VIEW**

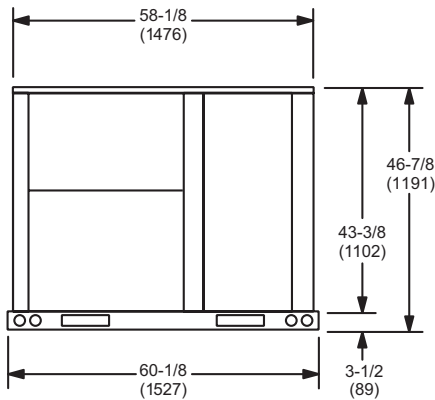

**END VIEW**

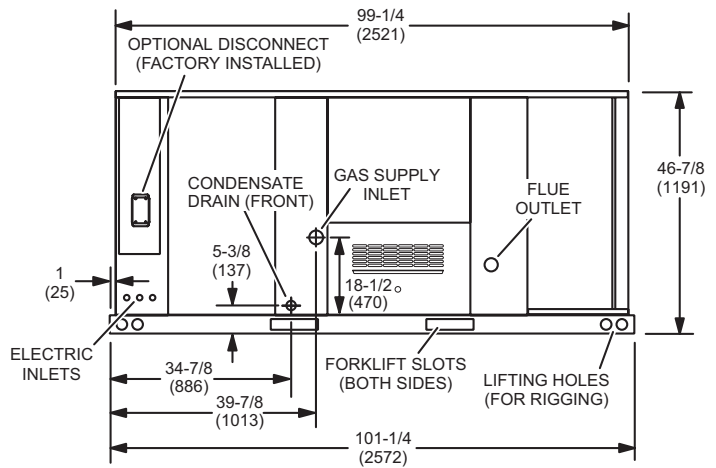

**SIDE VIEW**

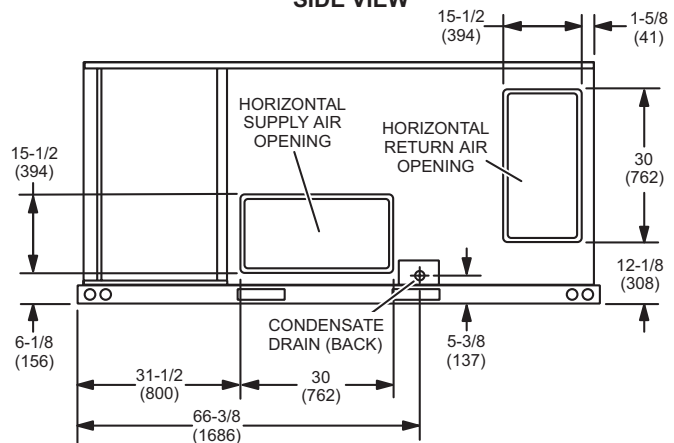

**SIDE VIEW  
(Horizontal Openings)**

**OUTDOOR AIR HOOD DETAIL**

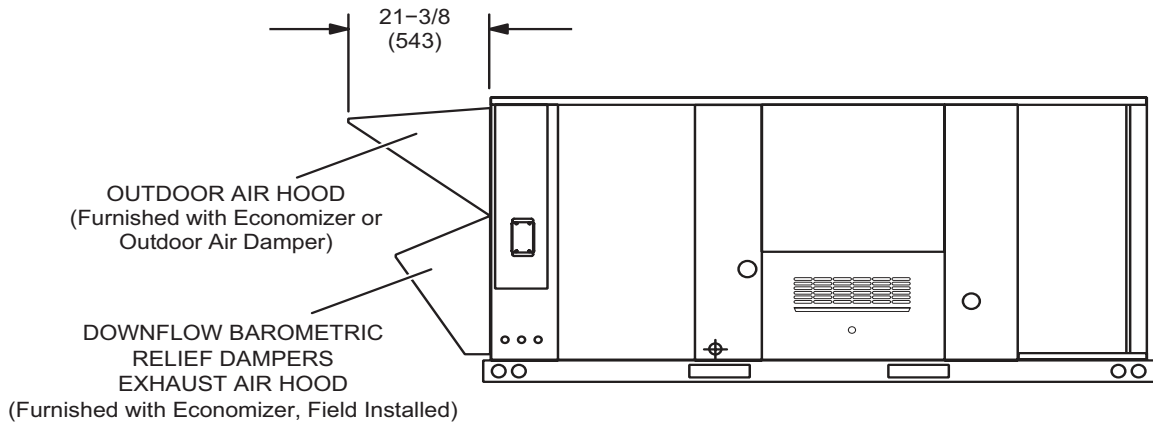

**HORIZONTAL ECONOMIZER APPLICATION**

(With Furnished Barometric Relief Dampers and Optional Horizontal Discharge Kit - Required)

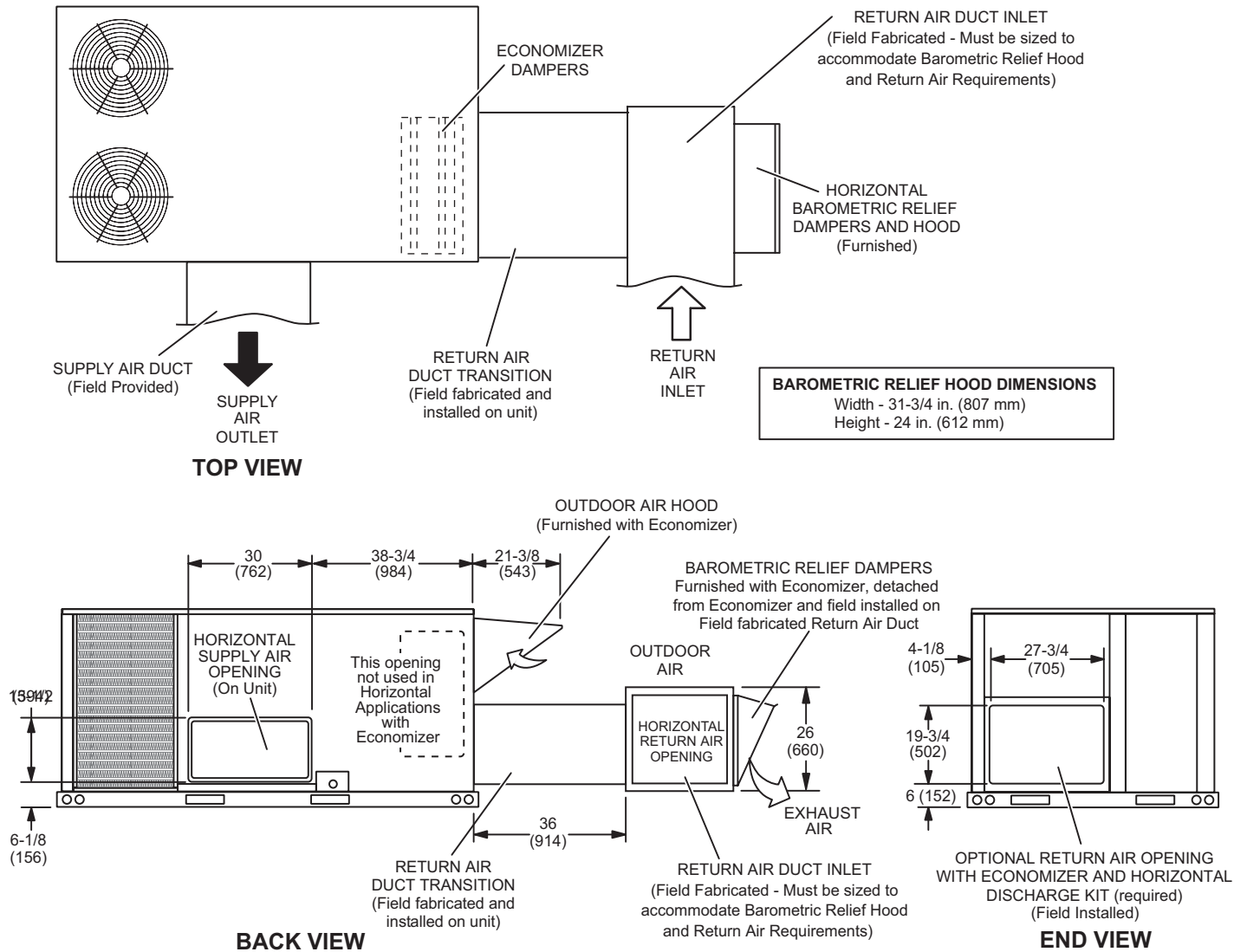

**NOTE** - Return Air Duct and Transition must be supported.

**BAROMETRIC RELIEF DAMPERS  
(Furnished with Economizer)**

(Field installed in horizontal return air duct adjacent to unit)

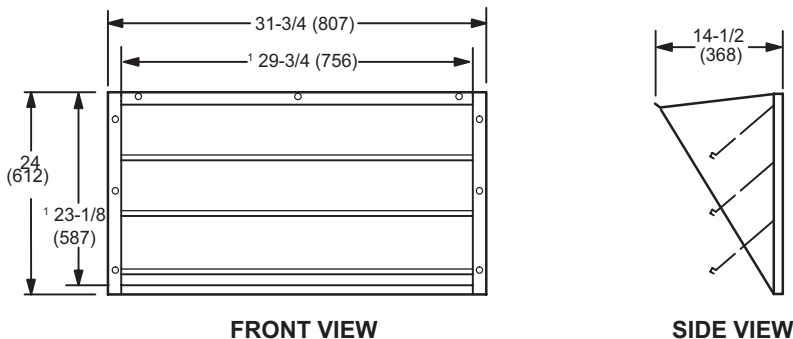

<sup>1</sup> NOTE - Opening size required in return air duct.

**HORIZONTAL ECONOMIZER APPLICATION**

(with Optional Low Profile Horizontal Barometric Relief Dampers and Horizontal Discharge Kit - Required)

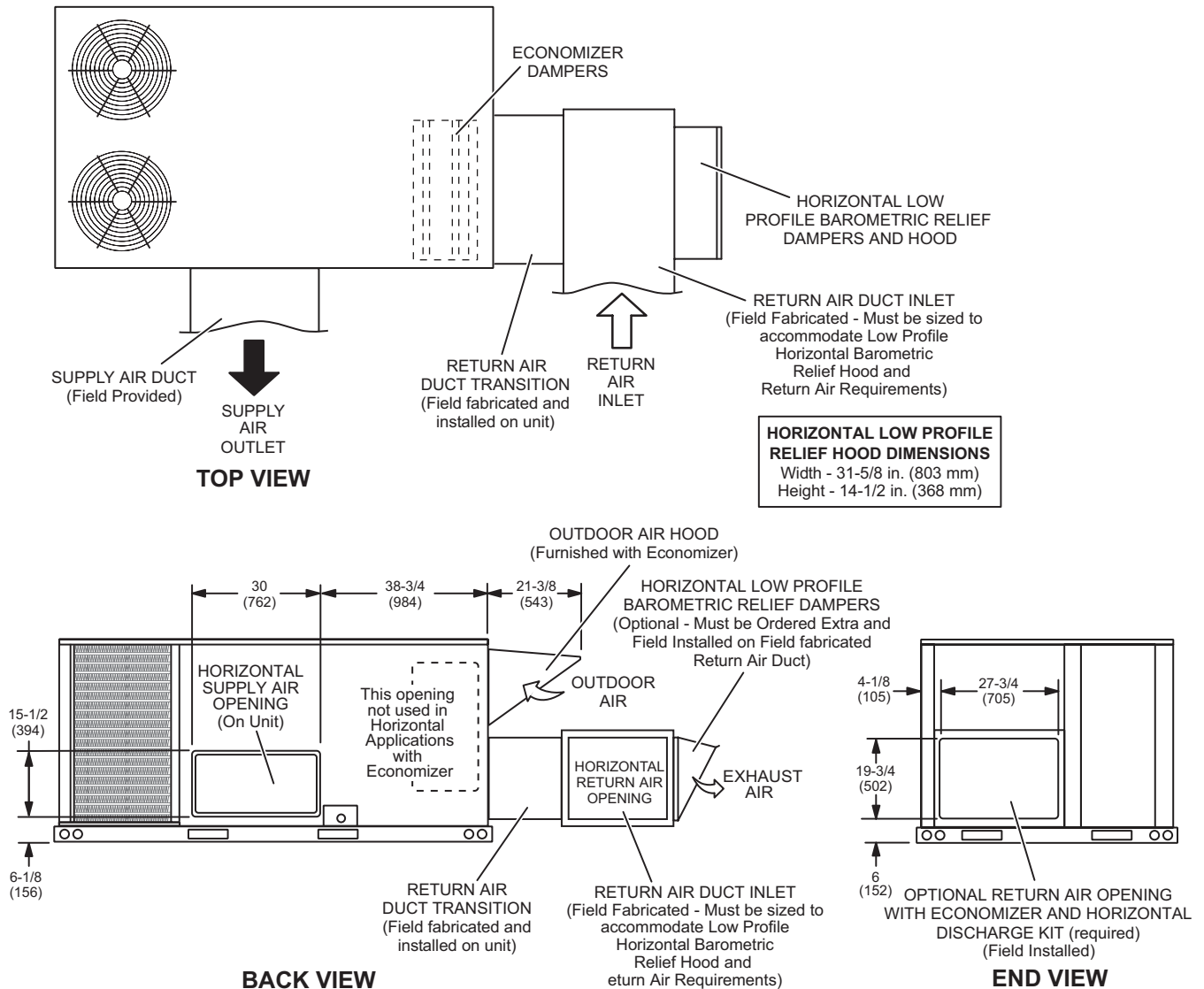

**NOTE** - Return Air Duct and Transition must be supported.

**HORIZONTAL LOW PROFILE BAROMETRIC RELIEF DAMPERS**  
 (Field installed in horizontal return air duct adjacent to unit)

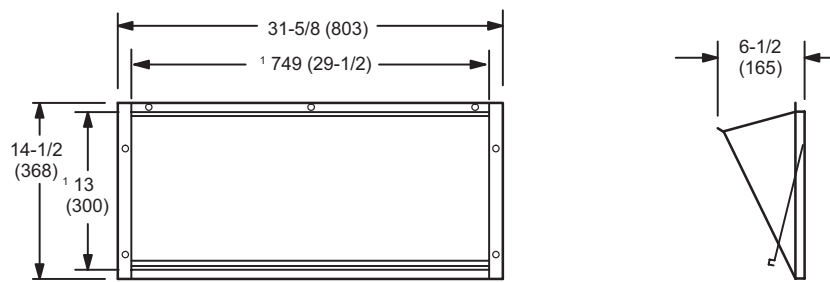

<sup>1</sup> NOTE - Opening size required in return air duct.

**HYBRID ROOF CURBS - DOUBLE DUCT OPENING**

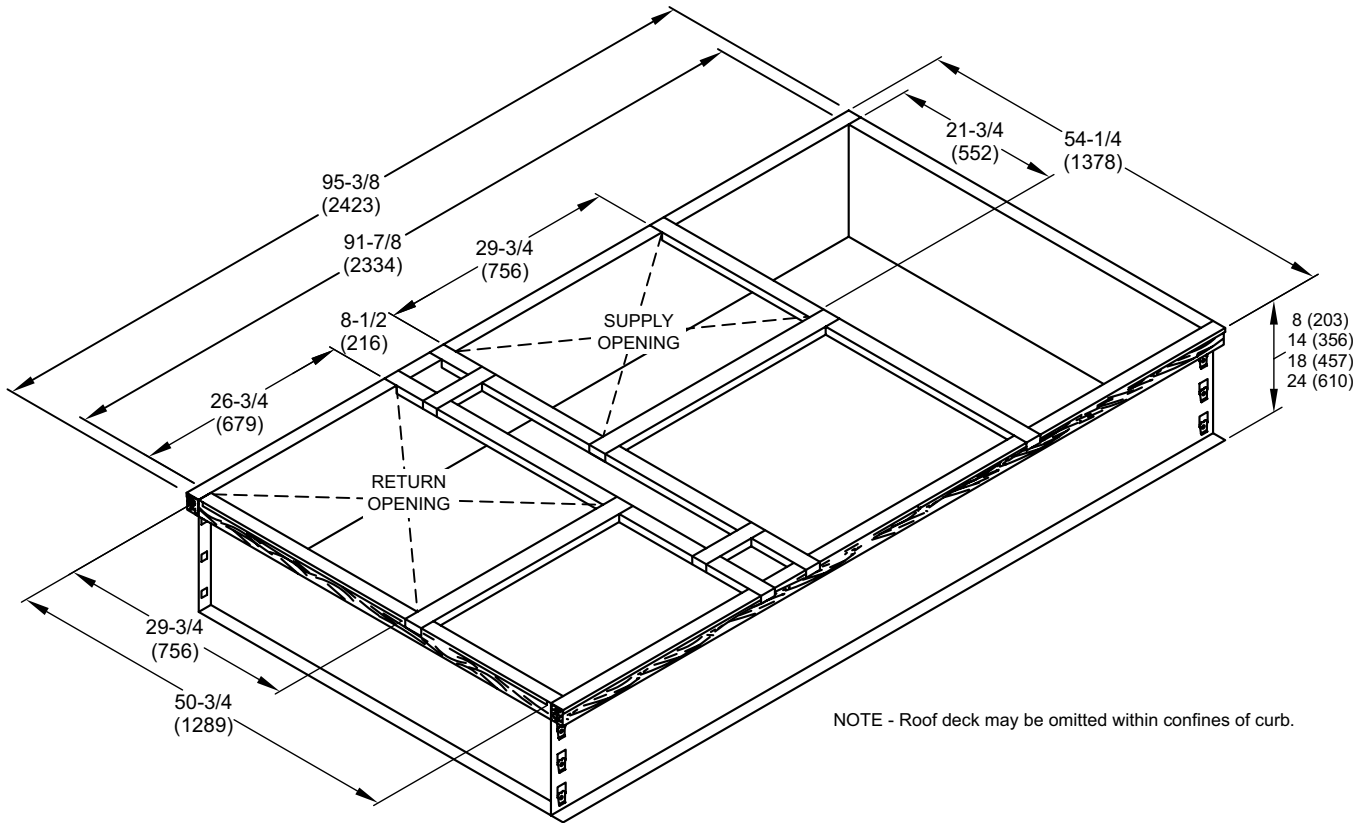

**TYPICAL FLASHING DETAIL FOR ROOF CURB**

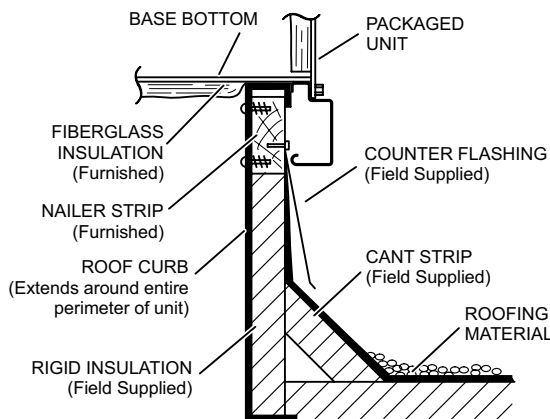

**DETAIL ROOF CURB**

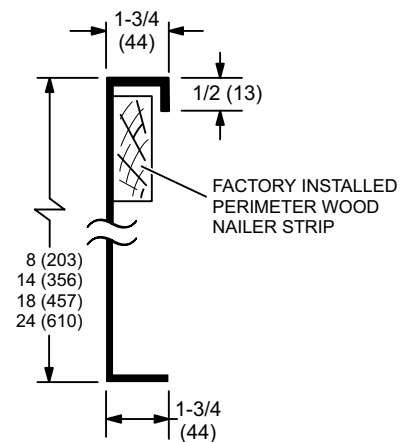



**ROOF CURBS WITH SUPPLY & RETURN AIR TRANSITIONS FOR CEILING DIFFUSERS**

**C1DIFF30B-1 ROUND TRANSITIONS**  
(for 092 models)

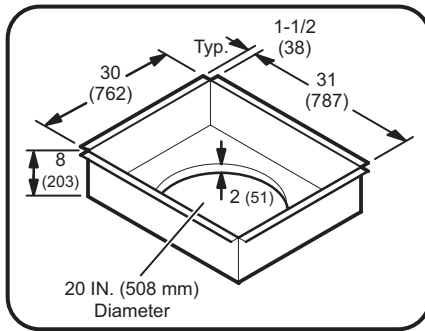

**C1DIFF31B-1 & C1DIFF32B-1 RECTANGULAR TRANSITIONS**  
(for 102 thru 150 models)

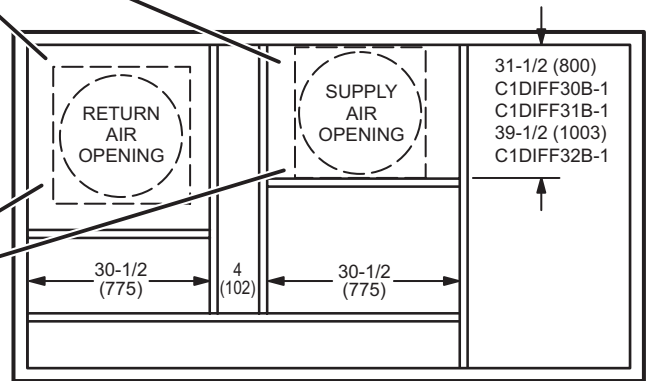
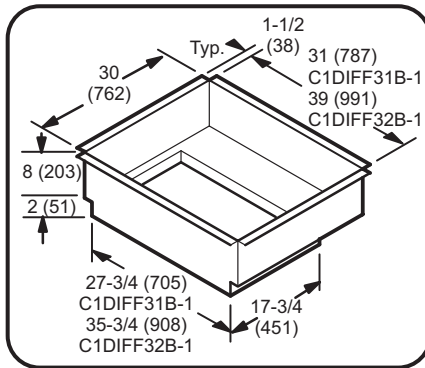

**TOP VIEW**

**COMBINATION CEILING SUPPLY AND RETURN DIFFUSERS**

**STEP-DOWN CEILING DIFFUSER**

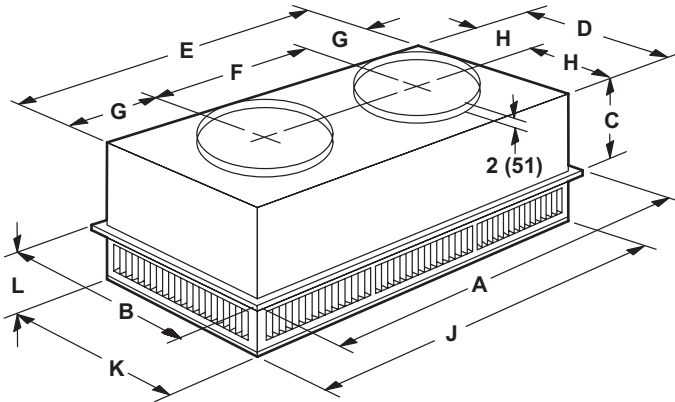

**FLUSH CEILING DIFFUSER**

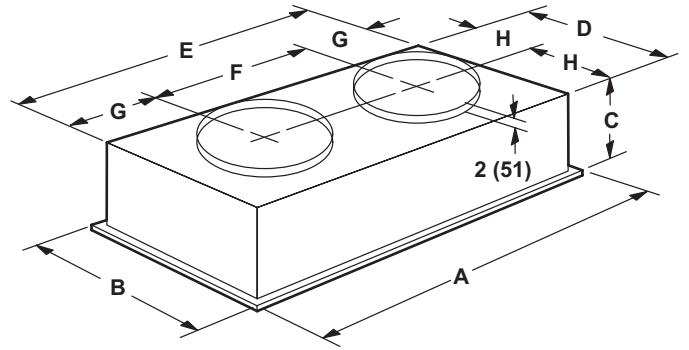

Model		RTD11-95S
A	in.	47-5/8
	mm	1159
B	in.	29-5/8
	mm	752
C	in.	14-3/8
	mm	365
D	in.	27-1/2
	mm	699
E	in.	45-1/2
	mm	1158
F	in.	22-1/2
	mm	572
G	in.	11-1/2
	mm	292
H	in.	13-3/4
	mm	349
J	in.	45-1/2
	mm	1156
K	in.	27-1/2
	mm	699
L	in.	8-1/8
	mm	206
Duct Size	in.	20 round
	mm	508 round

Model		FD11-95S
A	in.	47-5/8
	mm	1159
B	in.	29-5/8
	mm	752
C	in.	16-5/8
	mm	422
D	in.	27
	mm	686
E	in.	45
	mm	1143
F	in.	22-1/2
	mm	572
G	in.	11-1/4
	mm	286
H	in.	13-1/2
	mm	343
Duct Size	in.	20 round
	mm	508 round

**COMBINATION CEILING SUPPLY AND RETURN DIFFUSERS**  
**STEP-DOWN CEILING DIFFUSER**

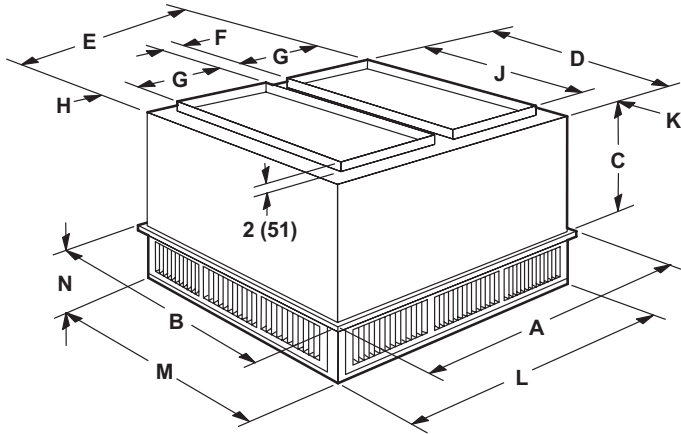

**FLUSH CEILING DIFFUSER**

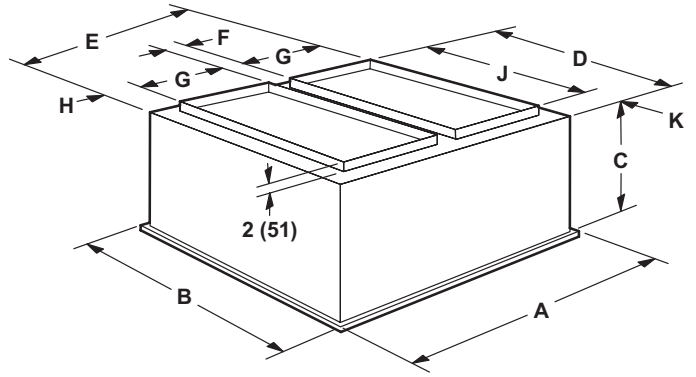

Model		RTD11-135S	RTD11-185S
A	in.	47-5/8	47-5/8
	mm	1210	1210
B	in.	35-5/8	47-5/8
	mm	905	1210
C	in.	20-5/8	24-5/8
	mm	524	625
D	in.	33-1/2	45-1/2
	mm	851	1156
E	in.	45-1/2	45-1/2
	mm	1156	1156
F	in.	4-1/2	4-1/2
	mm	114	114
G	in.	18	18
	mm	457	457
H	in.	2-1/2	2-1/2
	mm	64	64
J	in.	28	36
	mm	711	914
K	in.	2-3/4	4-3/4
	mm	70	121
L	in.	45-1/2	45-1/2
	mm	1156	1156
M	in.	33-1/2	45-1/2
	mm	851	1156
N	in.	9-1/8	10-1/8
	mm	232	257
Duct Size	in.	18 x 28	18 x 36
	mm	457 x 711	457 x 914

Model		FD11-135S	FD11-185S
A	in.	47-5/8	47-5/8
	mm	1210	1210
B	in.	35-5/8	47-5/8
	mm	905	1210
C	in.	23-1/4	29-1/4
	mm	591	743
D	in.	33	45
	mm	838	1143
E	in.	45	45
	mm	1143	1143
F	in.	4-1/2	4-1/2
	mm	114	114
G	in.	18	18
	mm	457	457
H	in.	2-1/4	2-1/4
	mm	57	57
J	in.	28	36
	mm	711	914
K	in.	2-1/2	4-1/2
	mm	64	114
Duct Size	in.	18 x 28	18 x 36
	mm	457 x 711	457 x 914



## REVISIONS

Sections	Description of Change
Options / Accessories	Added modulating gas option.



**Intertek**



**HRAI**  
✓ MEMBER COMPANY



Visit us at [www.Lennox.com](http://www.Lennox.com)

For the latest technical information, [www.LennoxCommercial.com](http://www.LennoxCommercial.com)

Contact us at 1-800-4-LENNOX

NOTE - Due to Lennox' ongoing commitment to quality, Specifications, Ratings and Dimensions subject to change without notice and without incurring liability. Improper installation, adjustment, alteration, service or maintenance can cause property damage or personal injury. Installation and service must be performed by a qualified installer and servicing agency.

©2026 Lennox Industries, Inc.