

**INSTALLATION INSTRUCTIONS FOR THERMISTOR KITS USED ON
LC/LG/LH/LD/SC/SG 024-360 PACKAGED UNITS - WITH R454B**

Shipping and Packing List

Package 1 of 1 contains:

- 4- Thermistors with wire harnesses for 22J07, 22J09
- 5- Thermistors with wire harnesses for 22J06
- 6- Thermistors with wire harnesses for 22J08, 23V50

⚠ WARNING

To prevent serious injury or death:

1. Lock-out/tag-out before performing maintenance.
2. If system power is required (e.g., smoke detector maintenance), disable power to blower, remove fan belt where applicable, and ensure all controllers and thermostats are set to the "OFF" position before performing maintenance.
3. Always keep hands, hair, clothing, jewelry, tools, etc., away from moving parts.

Check packaging for shipping damage. Contact the last carrier immediately if any shipping damage is found.

Application

Units are equipped with factory-installed thermistors located on different points on the refrigerant circuit. The thermistors provide the Unit Controller with constant temperature readings. These temperatures are used as feedback in certain modes of unit operation. In addition, the Unit Controller uses these temperatures to initiate alarms such as loss of outdoor or indoor coil airflow and loss of charge.

Each thermistor must be specifically placed for proper unit operation and to initiate valid alarms. For proper locations and kit application, see table 1 through 4 for LGM/LCM units and tables 5 through 21 for LGT/LCT/LHT/LDT/LCX/LGX/LHX units.

NOTE - Multiple thermistors are provided in each kit but not all thermistors are used in each application.

To use the tables below:

- 1 - Locate the unit model number of the equipment you are working on from the appropriate table below (Tables 1-21 on pgs. 1-3)
- 2 - Match the category number (Cat. No.) in the first column to the category number of the part you need.
- 3 - Match the assembly number (Ass'y. No.) in the second column to the part you need to install.
- 4 - Match the sensor color column to the part you need to install.

5 - Use the figure column to identify which of the figures below to reference for installation locations. Figures begin on page 4.

TABLE 1

LGM/LCM036, 048, 060, 074

Cat. No.	Ass'y. No.	Sensor Yellow	Figure
22J06	623049-01	RT46	FIGURE 8
22J07	623049-02	RT42	FIGURE 8
22J08	623049-03	RT48	FIGURE 11
22J09	623049-04	RT44	FIGURE 12

TABLE 2

LGM/LCM092, 102, 120, 150

Cat. No.	Ass'y. No.	Sensor Yellow, Blue	Figure
22J06	623049-01	RT46, 47	FIGURE 2
22J07	623049-02	RT42, 43	FIGURE 2
23V50	623049-05	RT48, 49	FIGURE 3
22J09	623049-04	RT44, 45	FIGURE 3

TABLE 3

LGM/LCM156, 180

Cat. No.	Ass'y. No.	Sensor Yel, Blue, Red	Figure
22J06	623049-01	RT46, 47, 50	FIGURE 4
22J07	623049-02	RT42, 43, 54	FIGURE 4
23V50	623049-05	RT48, 49, 52	FIGURE 6
22J09	623049-04	RT44, 45, 56	FIGURE 6

TABLE 4

LGM/LCM210, 240, 300

Cat. No.	Ass'y. No.	Sensor Yel, Blu, Red, Grn	Figure
22J06	623049-01	RT46, 47, 50, 51	FIGURE 5
22J07	623049-02	RT42, 43, 54, 55	FIGURE 5
23V50	623049-05	RT48, 49, 52, 53	FIGURE 7
22J09	623049-04	RT44, 45, 56, 57	FIGURE 7



⚠WARNING

Improper installation, adjustment, alteration, service or maintenance can cause property damage, personal injury or loss of life. Installation and service must be performed by a licensed professional HVAC installer or equivalent, service agency, or the gas supplier.

⚠CAUTION

As with any mechanical equipment, contact with sharp sheet metal edges can result in personal injury. Take care while handling this equipment and wear gloves and protective clothing.

TABLE 5

LHT/LDT036, 048, 060, 072

Cat. No.	Ass'y. No.	Sensor Yellow	Figure
22J06	623049-01	RT46	FIGURE 1

TABLE 6

LGT/LCT/SGH/SCH036, 048, 060, 072

Cat. No.	Ass'y. No.	Sensor Yellow	Figure
22J06	623049-01	RT46	FIGURE 8

TABLE 7

LHT/LDT036, 048

Cat. No.	Ass'y. No.	Sensor Yellow	Figure
22J08	623049-03	RT48	FIGURE 9

TABLE 8

LHT/LDT060, 072

Cat. No.	Ass'y. No.	Sensor Yellow	Figure
22J08	623049-03	RT48	FIGURE 10

TABLE 9

LGT/LCT/SGH/SCH036, 048, 060, 072

Cat. No.	Ass'y. No.	Sensor Yellow	Figure
22J08	623049-05	RT48	FIGURE 11

TABLE 10

LGT/LCT156, SGH/SCH120

Cat. No.	Ass'y. No.	Sensor Yellow, Blue	Figure
22J06	623049-01	RT46, 47	FIGURE 13
23V50	623049-05	RT48, 49	FIGURE 17

TABLE 11

LGT/LCT180

Cat. No.	Ass'y. No.	Sensor Yellow, Blue, Red	Figure
22J06	623049-01	RT46, 47, 50	FIGURE 14
23V50	623049-05	RT48, 49, 52	FIGURE 18

TABLE 12

LGT/LCT210, 240, 300

Cat. No.	Ass'y. No.	Sensor Yel, Blue, Red, Grn	Figure
22J06	623049-01	RT46, 47, 50, 51	FIGURE 15
23V50	623049-05	RT48, 49, 52, 53	FIGURE 19

TABLE 13

LGT/LCT302, 360; SGH/SCH240

Cat. No.	Ass'y. No.	Sensor Yel, Blue, Red, Grn	Figure
22J06	623049-01	RT46, 47, 50, 51	FIGURE 16
23V50	623049-05	RT48, 49, 52, 53	FIGURE 20

TABLE 14

LGT/LCT092, 102, 120, 150

Cat. No.	Ass'y. No.	Sensor Yellow, Blue	Figure
22J06	623049-01	RT46, 47	FIGURE 21
23V50	623049-05	RT48, 49	FIGURE 22

TABLE 15

LHT/LDT078, 092, 102, 120, 152

Cat. No.	Ass'y. No.	Sensor Yellow, Blue	Figure
22J06	623049-01	RT46, 47	FIGURE 23
22J08	623049-03	RT48, 49	FIGURE 24

TABLE 16

LHT/LDT156, 180, 240, LHX180, 240, 300

Cat. No.	Ass'y. No.	Sensor Yellow, Blue	Figure
22J06	623049-01	RT46, 47	FIGURE 25
22J08	623049-03	RT48, 49	FIGURE 26, FIGURE 29, FIGURE 30

TABLE 17

LCX/LGX180, 210, 240, 300

Cat. No.	Ass'y. No.	Sensor Yellow, Blue	Figure
22J06	623049-01	RT46, 47, 50	FIGURE 14
22J06	623049-01	RT46, 47, 50, 51	FIGURE 15

TABLE 18

LHT/LDT302

Cat. No.	Ass'y. No.	Sensor Yellow, Blue	Figure
22J06	623049-01	RT46, 47	FIGURE 27
22J08	623049-03	RT48, 49	FIGURE 28

TABLE 19

LCX/LGX092, 102, 120

Cat. No.	Ass'y. No.	Sensor Yellow, Blue	Figure
22J06	623049-01	RT46, 47	FIGURE 31

TABLE 20

LCX/LGX150

Cat. No.	Ass'y. No.	Sensor Yellow, Blue	Figure
22J06	623049-01	RT46, 47	FIGURE 21

TABLE 21

LHX092, 102, 120

Cat. No.	Ass'y. No.	Sensor Yellow, Blue	Figure
22J06	623049-01	RT46, 47	FIGURE 21
22J08	623049-03	RT48, 49	FIGURE 32

LHT/LDT036, 048, 060, 072
EVAPORATOR COIL
RT46

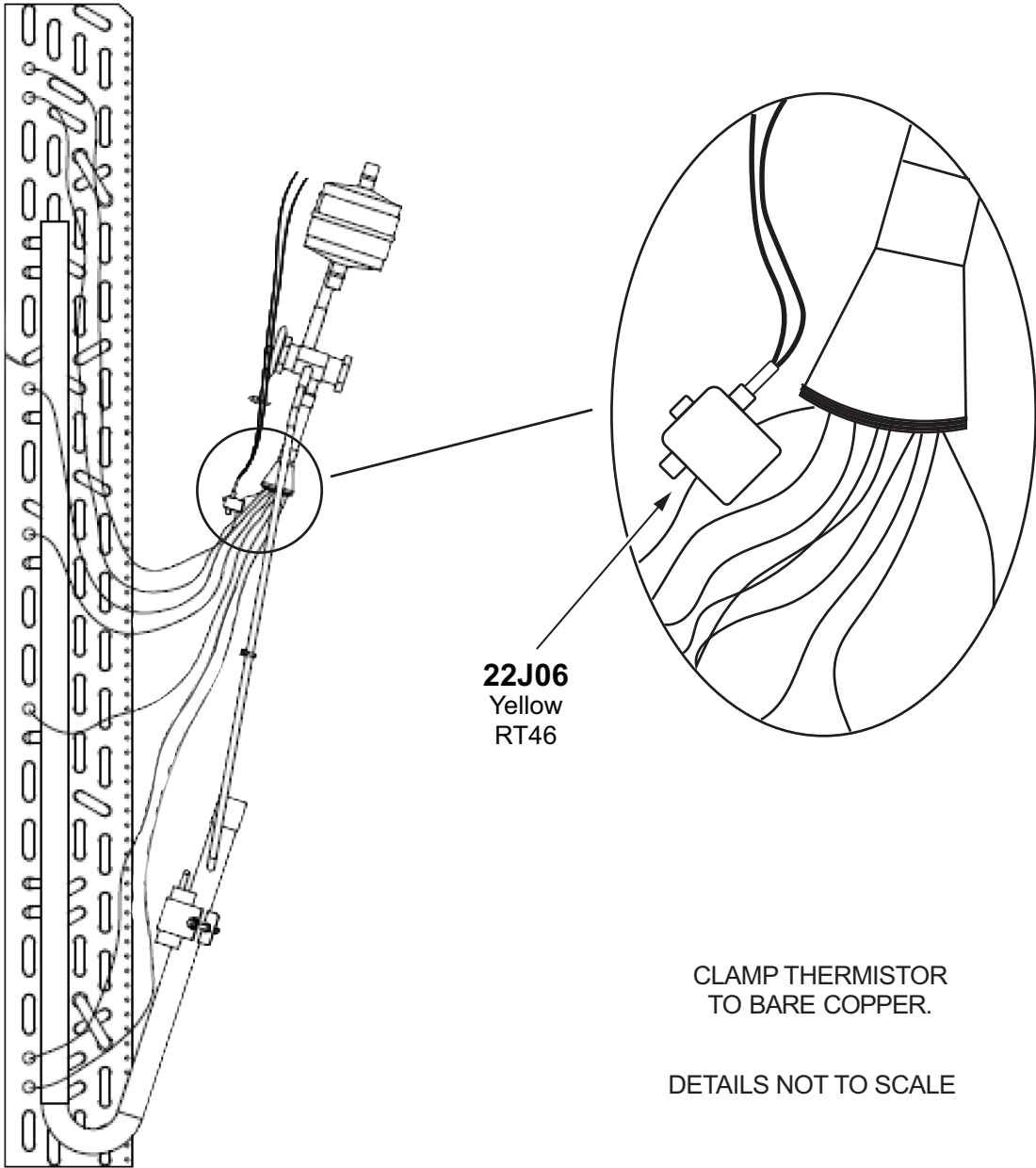

FIGURE 1

LGM/LCM092, 102, 120, 150
EVAPORATOR COIL
RT42, 43, 46, 47

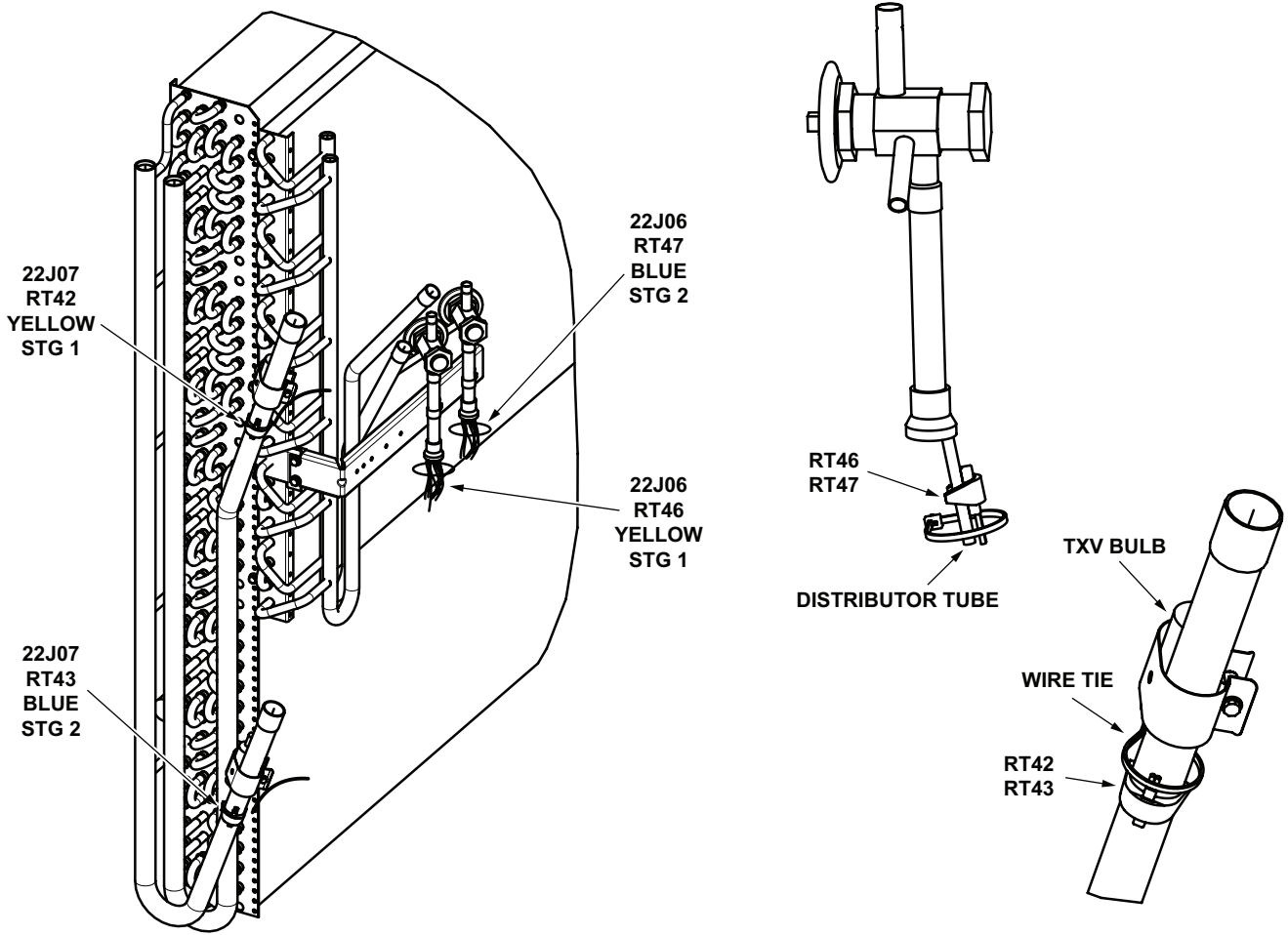

FIGURE 2

LGM/LCM092, 102, 120, 150
CONDENSER COIL
RT44, 45, 48, 49

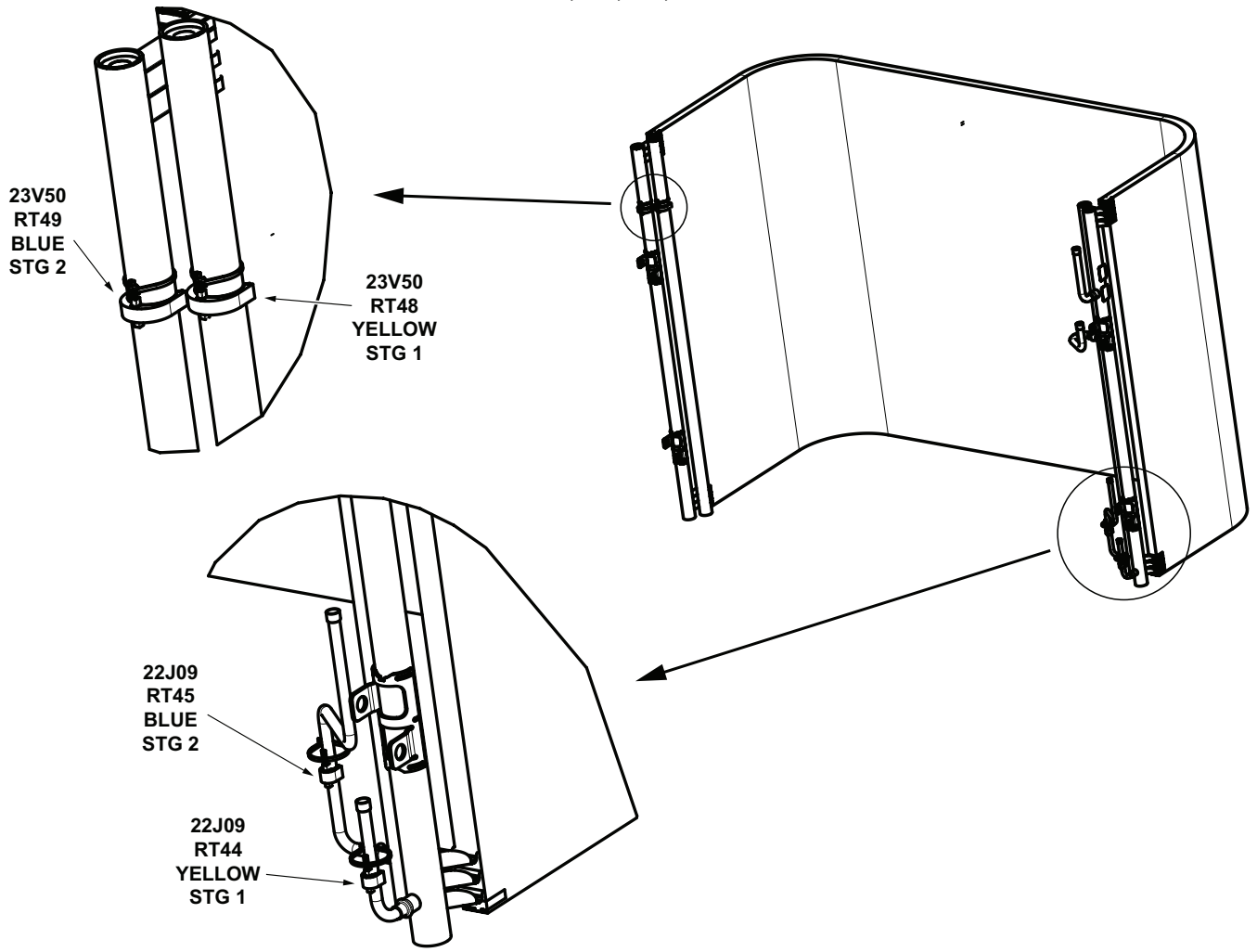

FIGURE 3

LGM/LCM156, 180
 THREE-ROW EVAPORATOR COIL
 RT42, RT43, RT46, RT47, RT50, RT54

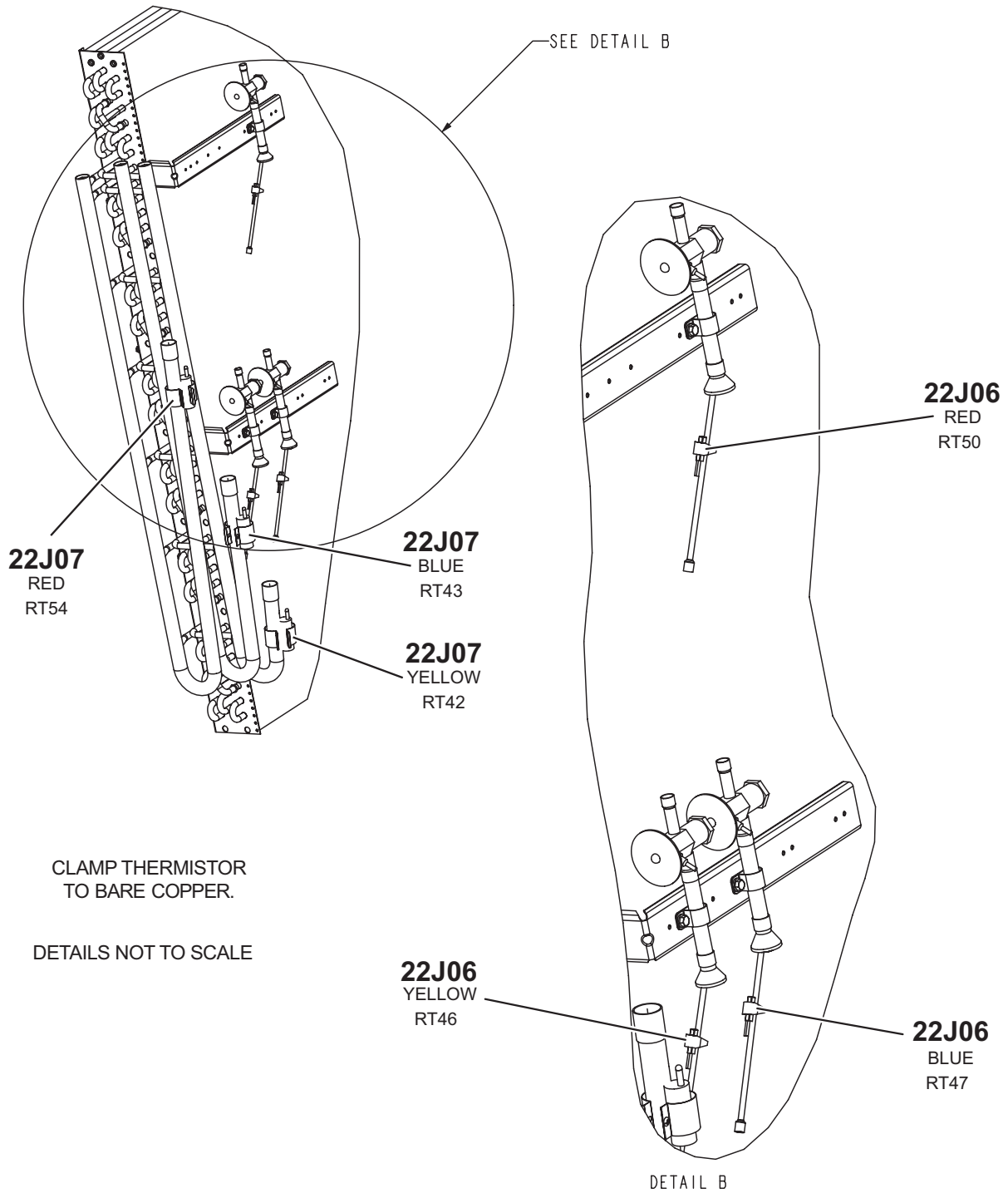

FIGURE 4

LGM/LCM210, 240, 300
 FOUR-ROW EVAPORATOR COIL
 RT42, RT43, RT46, RT47, RT50, RT51, RT54, RT55

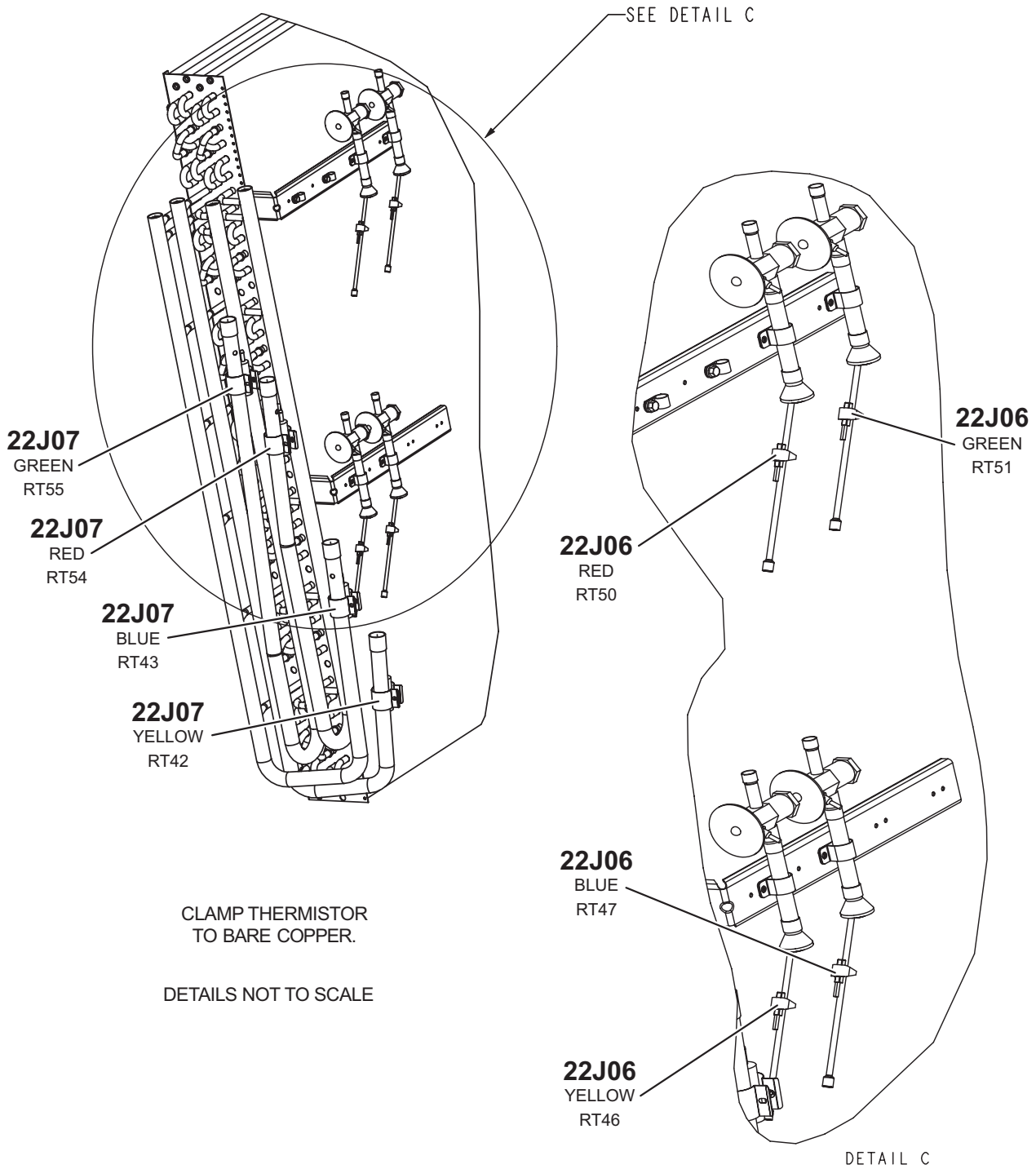

FIGURE 5

LGM/LCM156, 180
CONDENSOR COIL
RT44, RT45, RT48, RT49, RT52, RT56

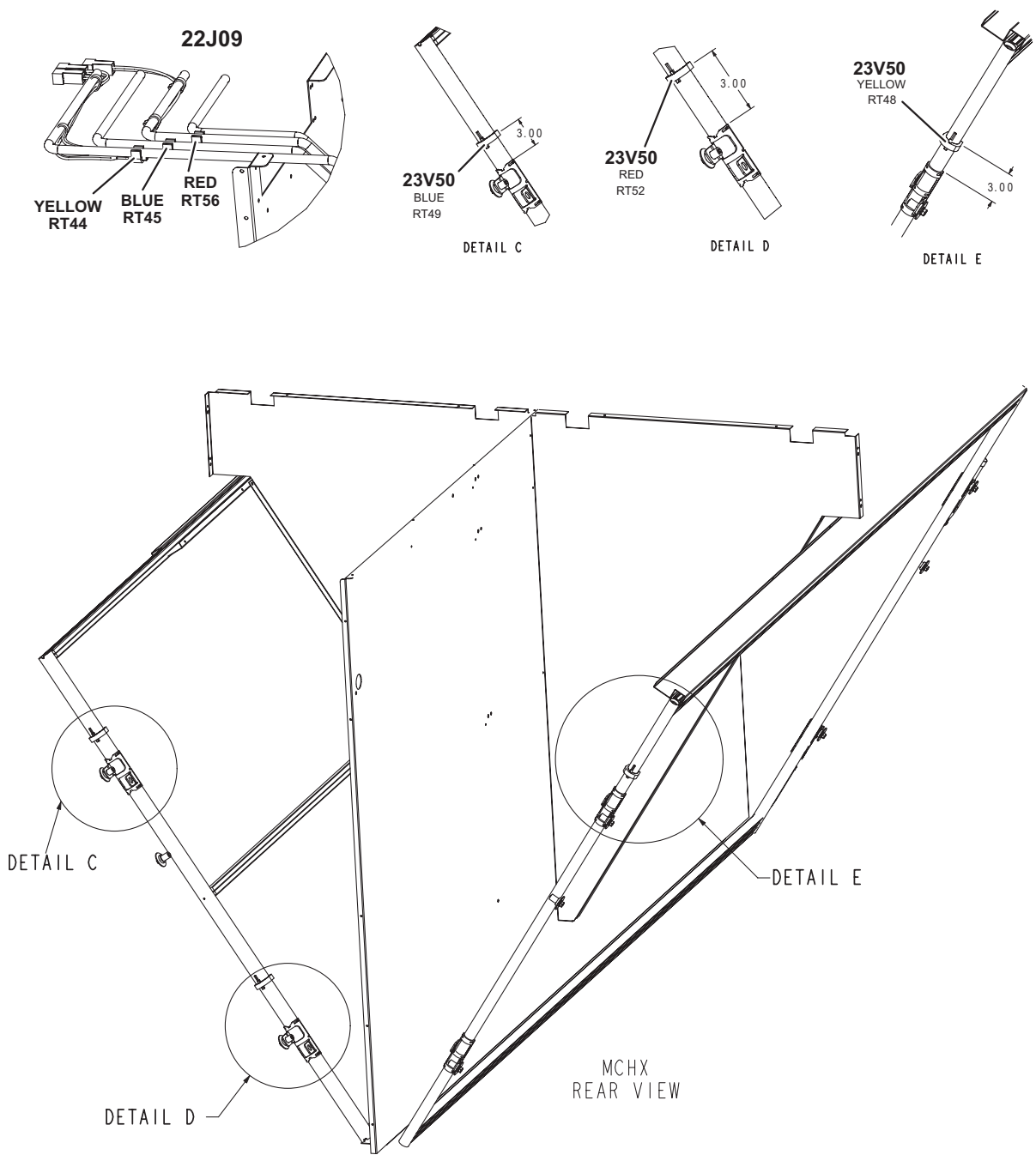

FIGURE 6

LGM/LCM210, 240, 300
 CONDENSOR COIL
 RT44, RT45, RT48, RT49, RT52, RT53, RT56, RT57

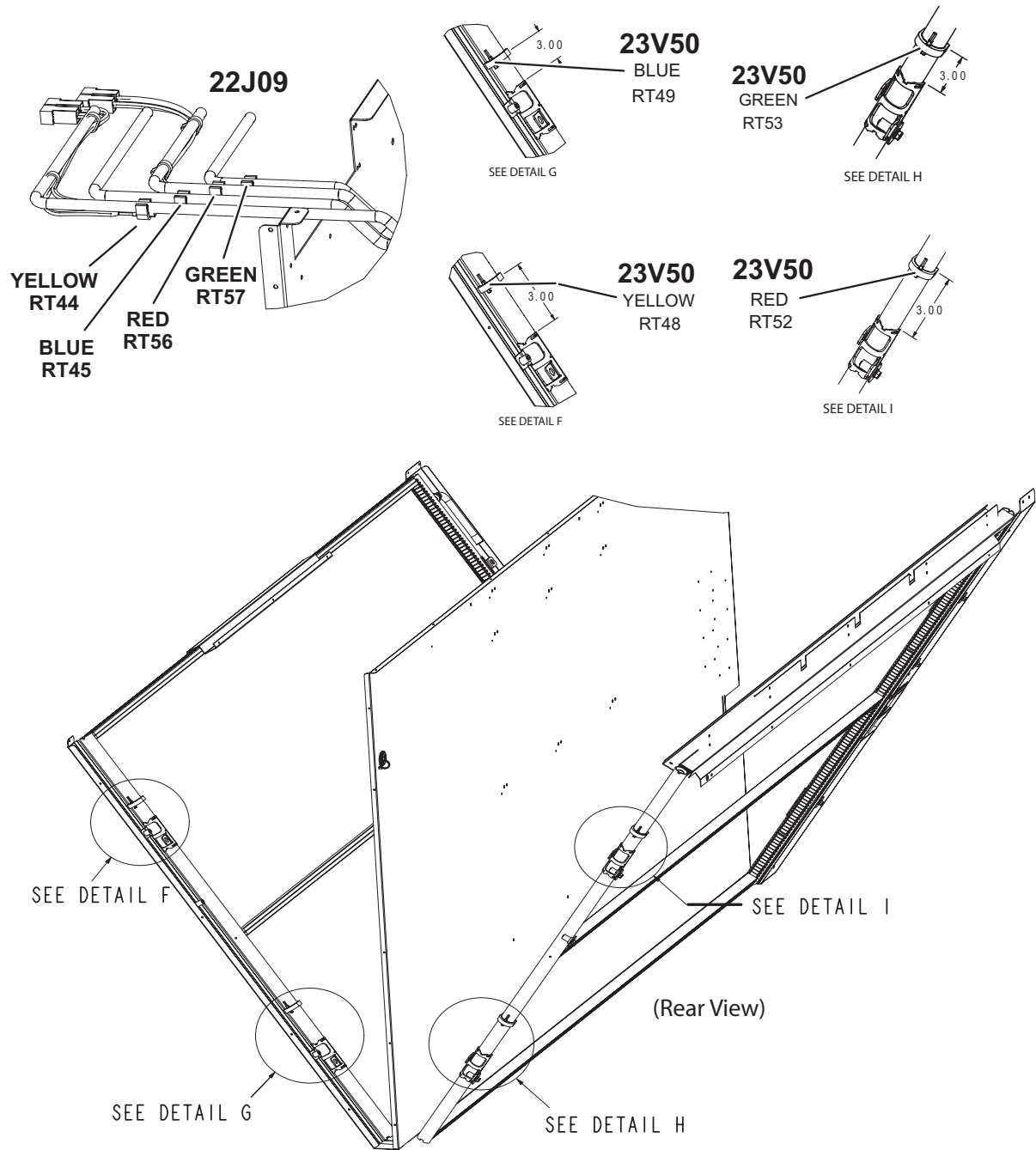
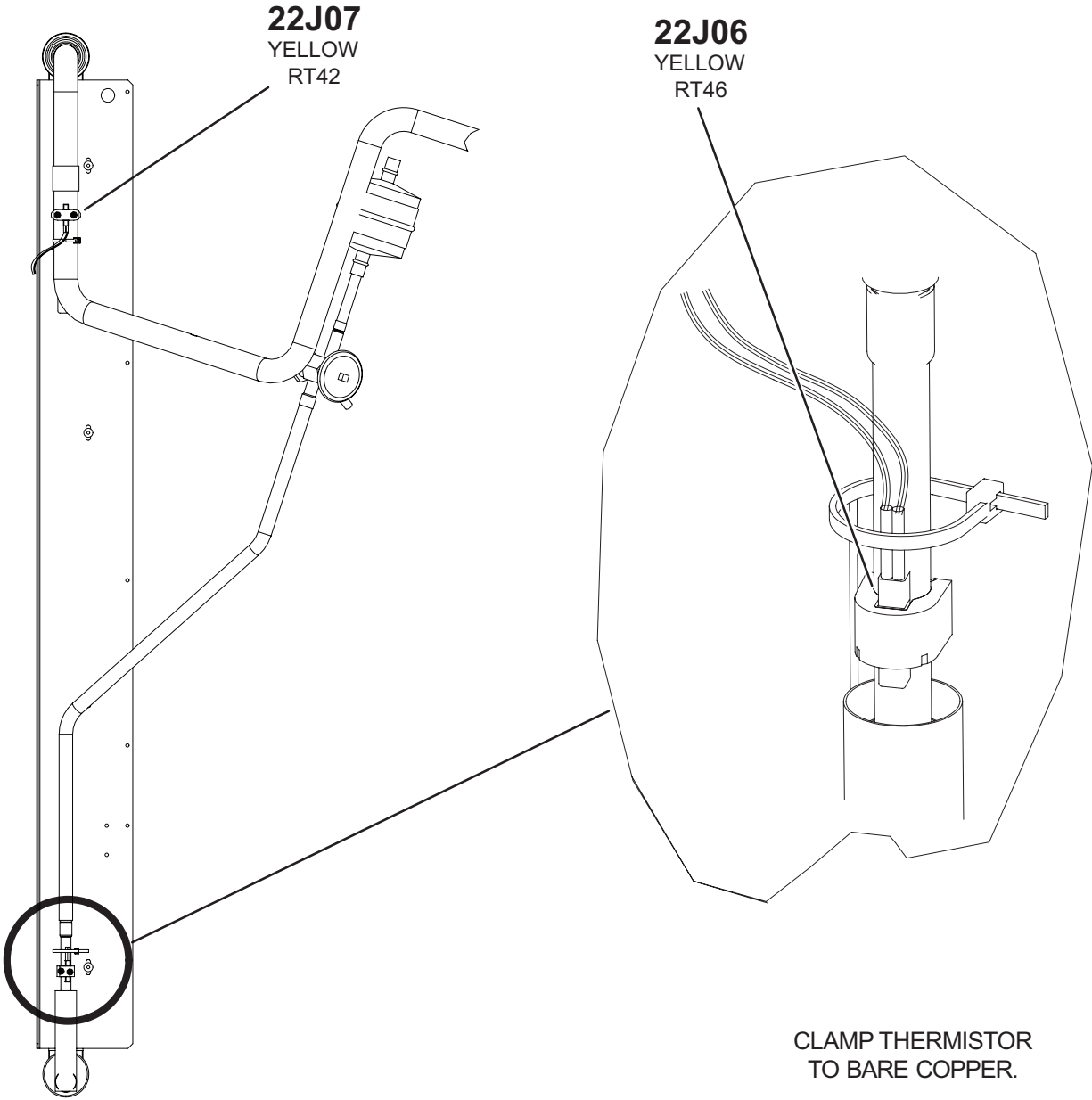

FIGURE 7

LGM/LCM/LGT/LCT/SGH/SCH036, 048, 060, 072/074
EVAPORATOR COIL
RT42, 46



DETAILS NOT TO SCALE

FIGURE 8

LHT/LDT036, 048
CONDENSER COIL
RT48

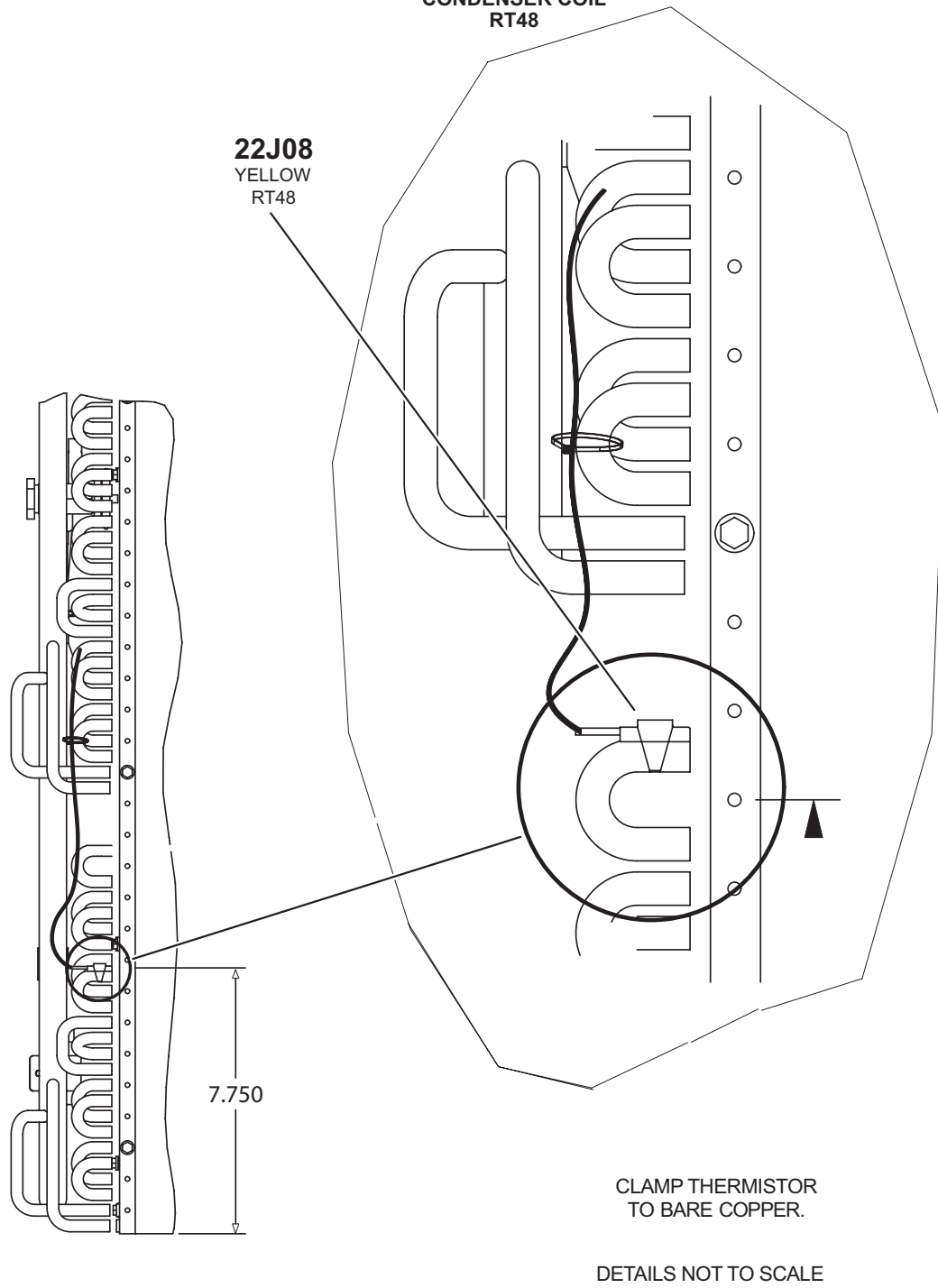
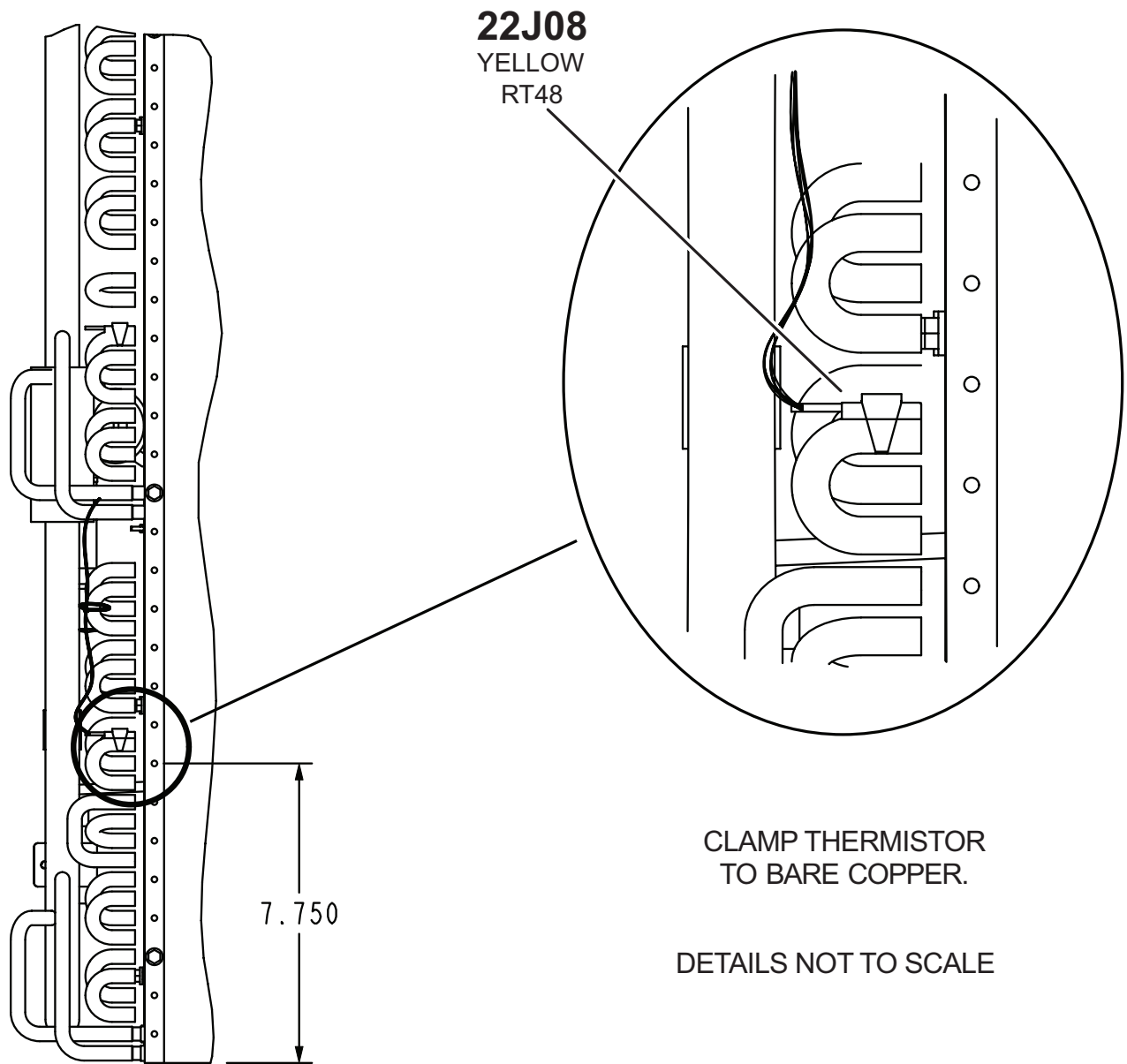

FIGURE 9

LHT/LDT060, 072
CONDENSER COIL
RT48



22J08
YELLOW
RT48

CLAMP THERMISTOR
TO BARE COPPER.

DETAILS NOT TO SCALE

FIGURE 10

LCM/LGM/LGT/LCT/SGH/SCH036, 048, 060, 072/074
CONDENSER COIL
RT48

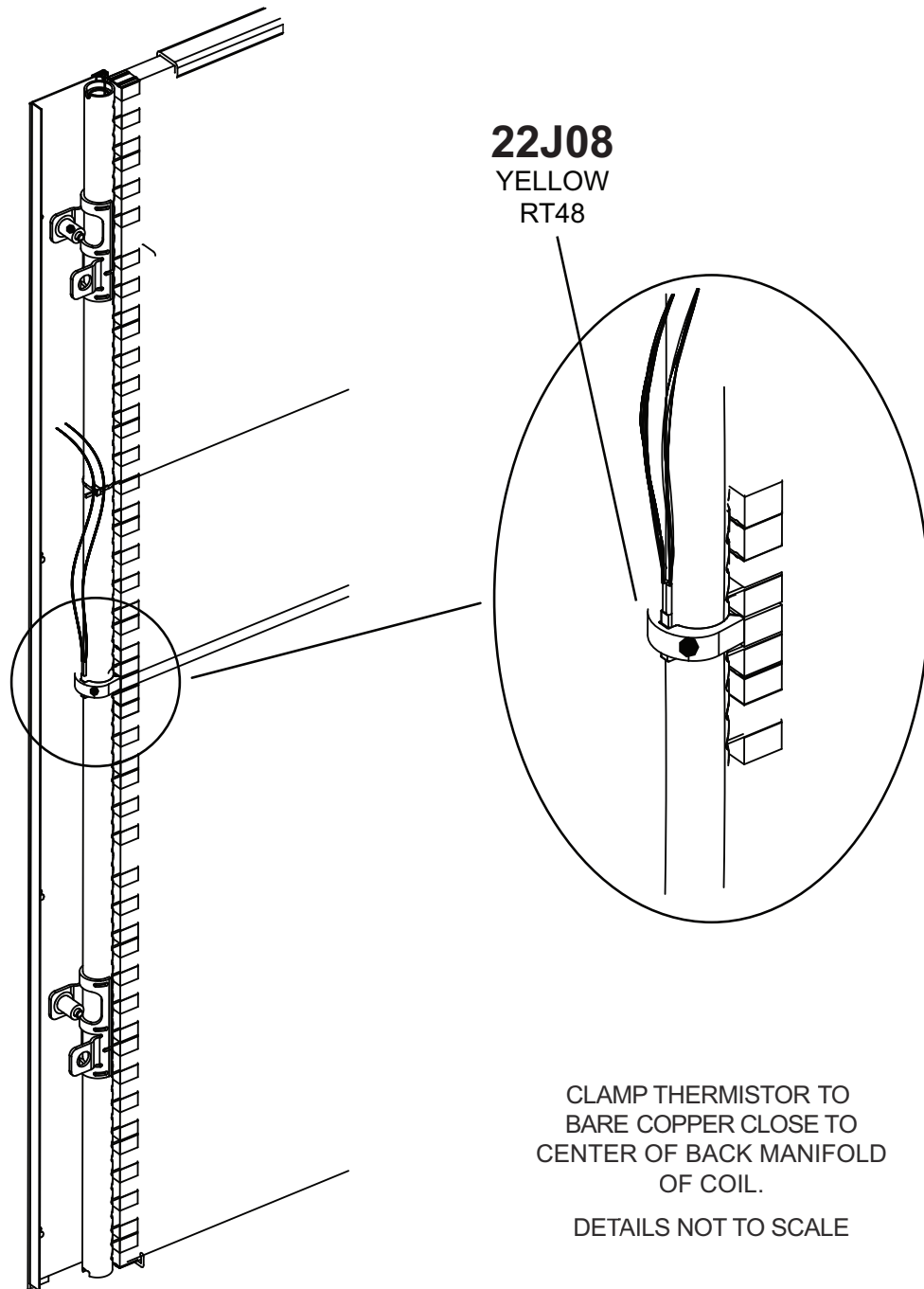

FIGURE 11

LGM/LCM036, 048, 060, 074U5
CONDENSER COIL
(RT44)

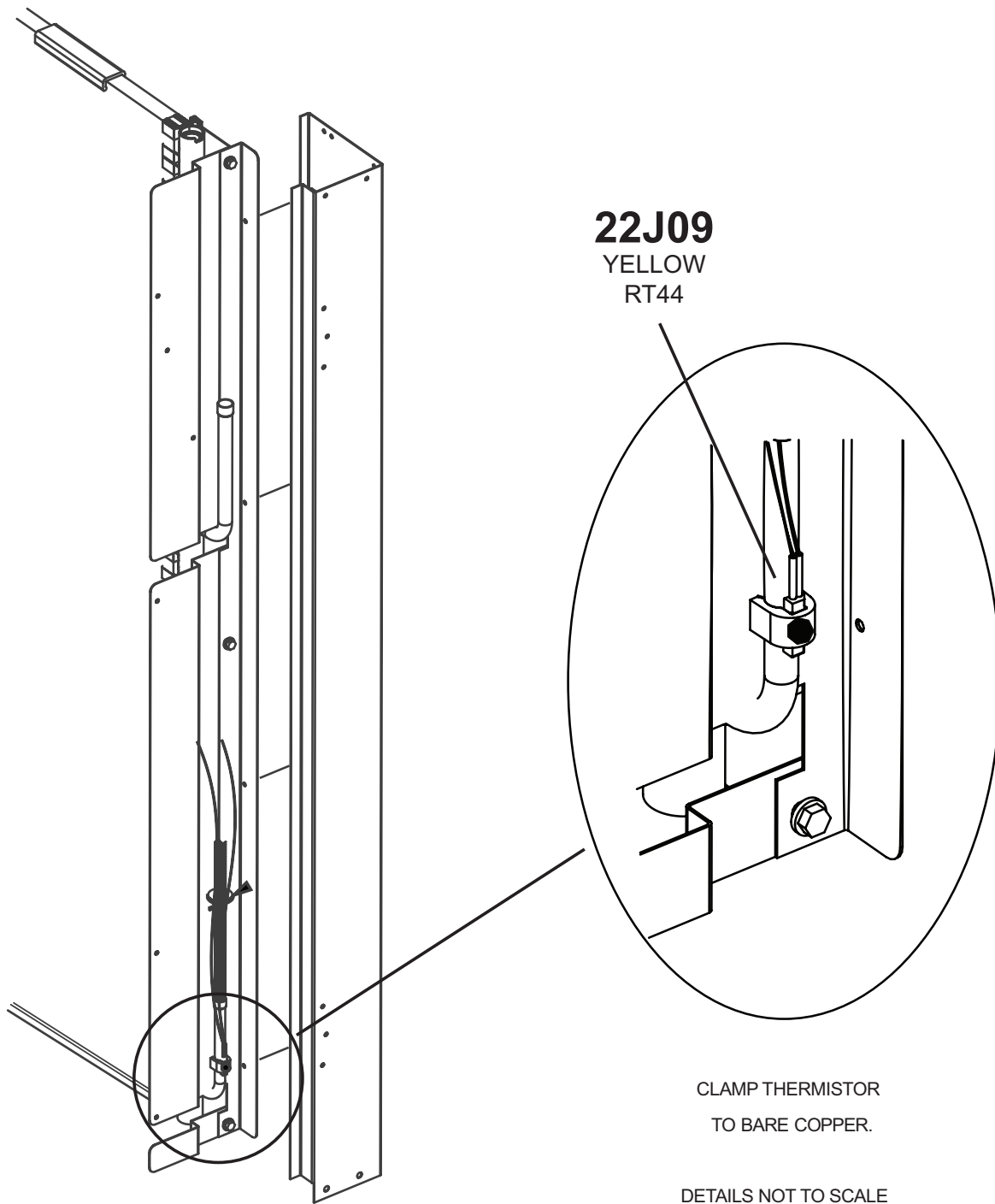

FIGURE 12

LGT/LCT156, SGH/SCH120
EVAPORATOR COIL
(RT46, 47)

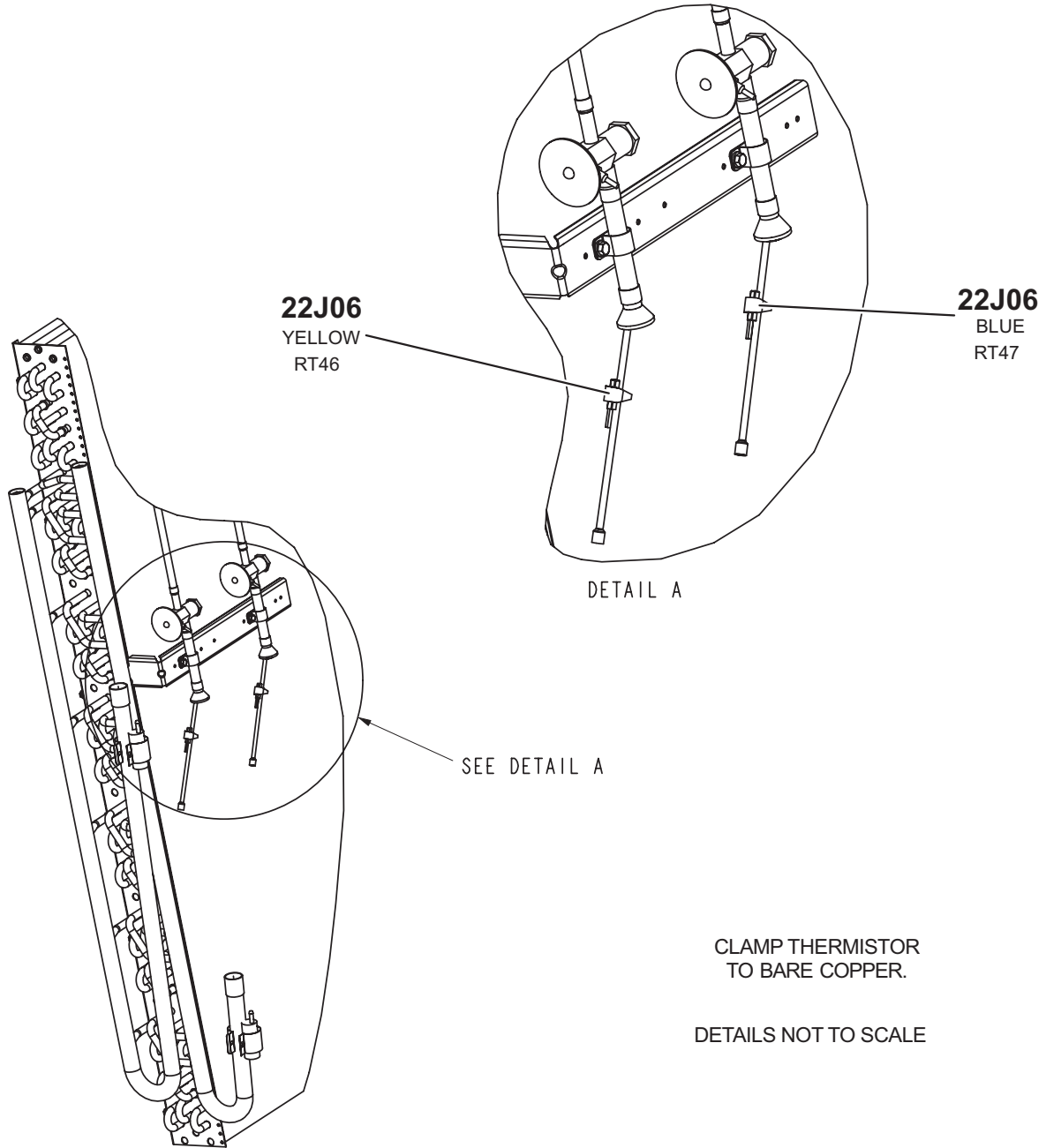

FIGURE 13

LGT/LCT180; LCX/LGX180, 210, 240
EVAPORATOR COIL
RT46, 47, 50

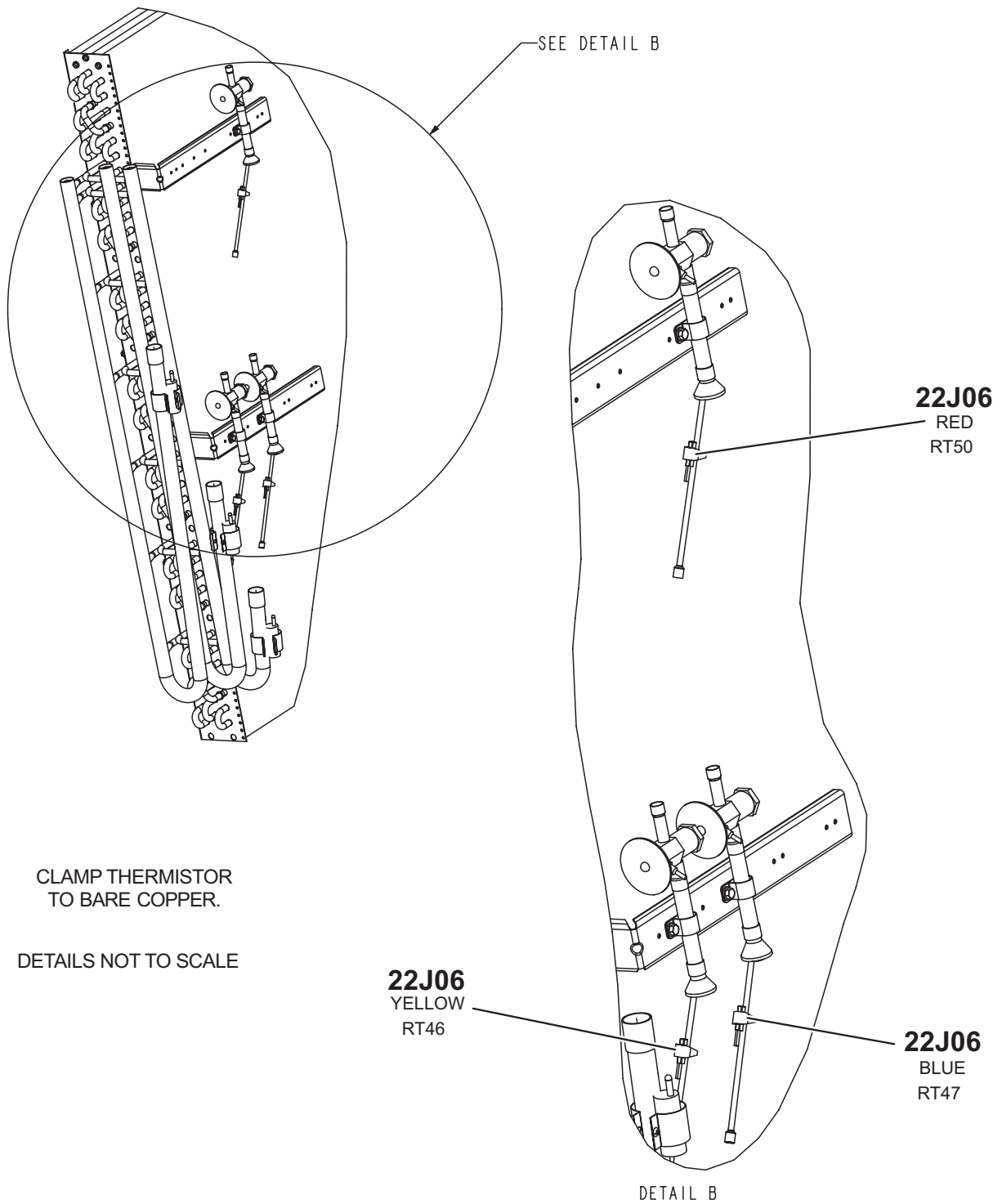

FIGURE 14

LGT/LCT210, 240, 300; LCX/LGX300
EVAPORATOR COIL
RT46, 47, 50, 51

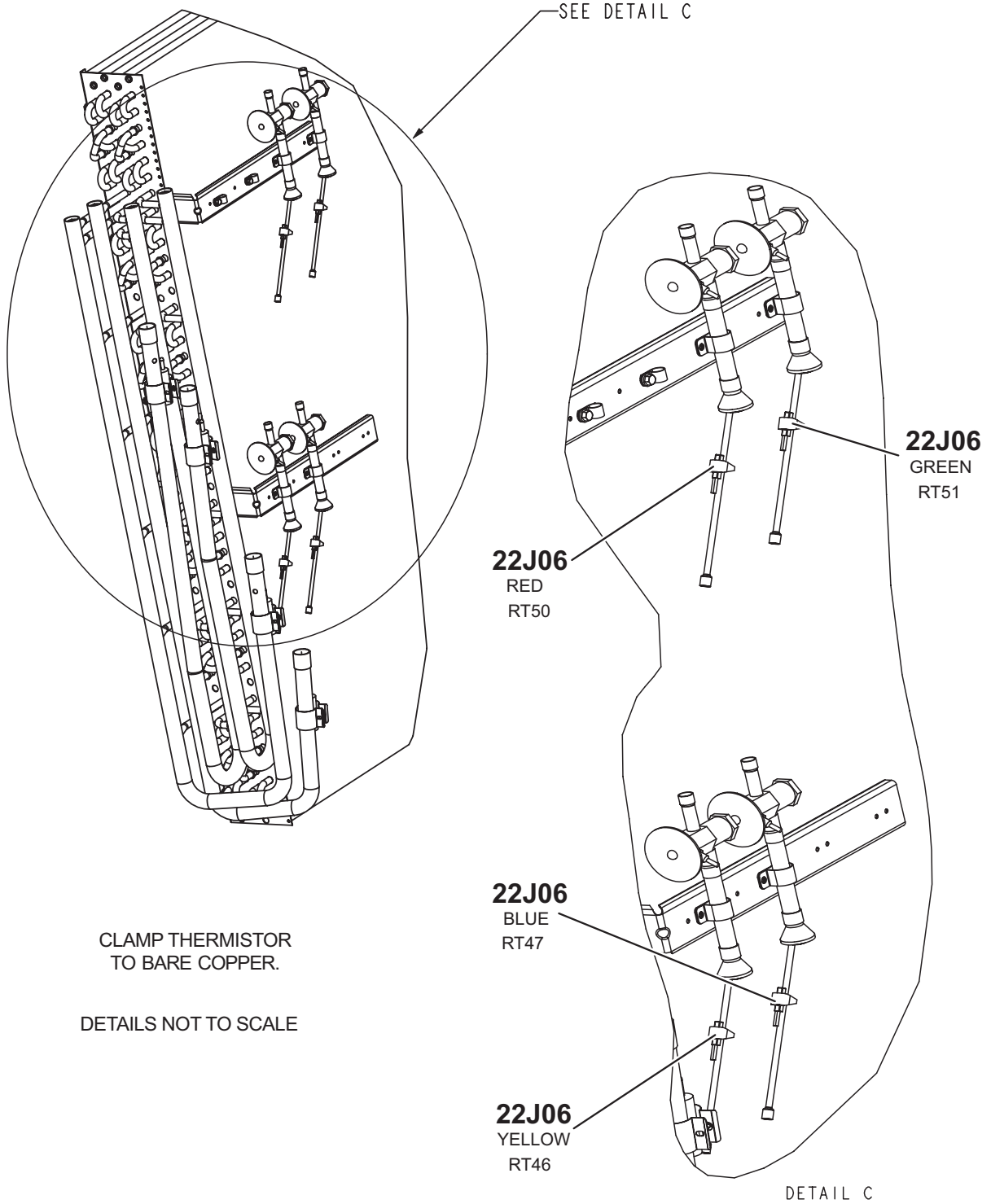

FIGURE 15

LGT/LCT302, 360, SGH/SCH240
EVAPORATOR COIL
(RT46, 47, 50, 51)

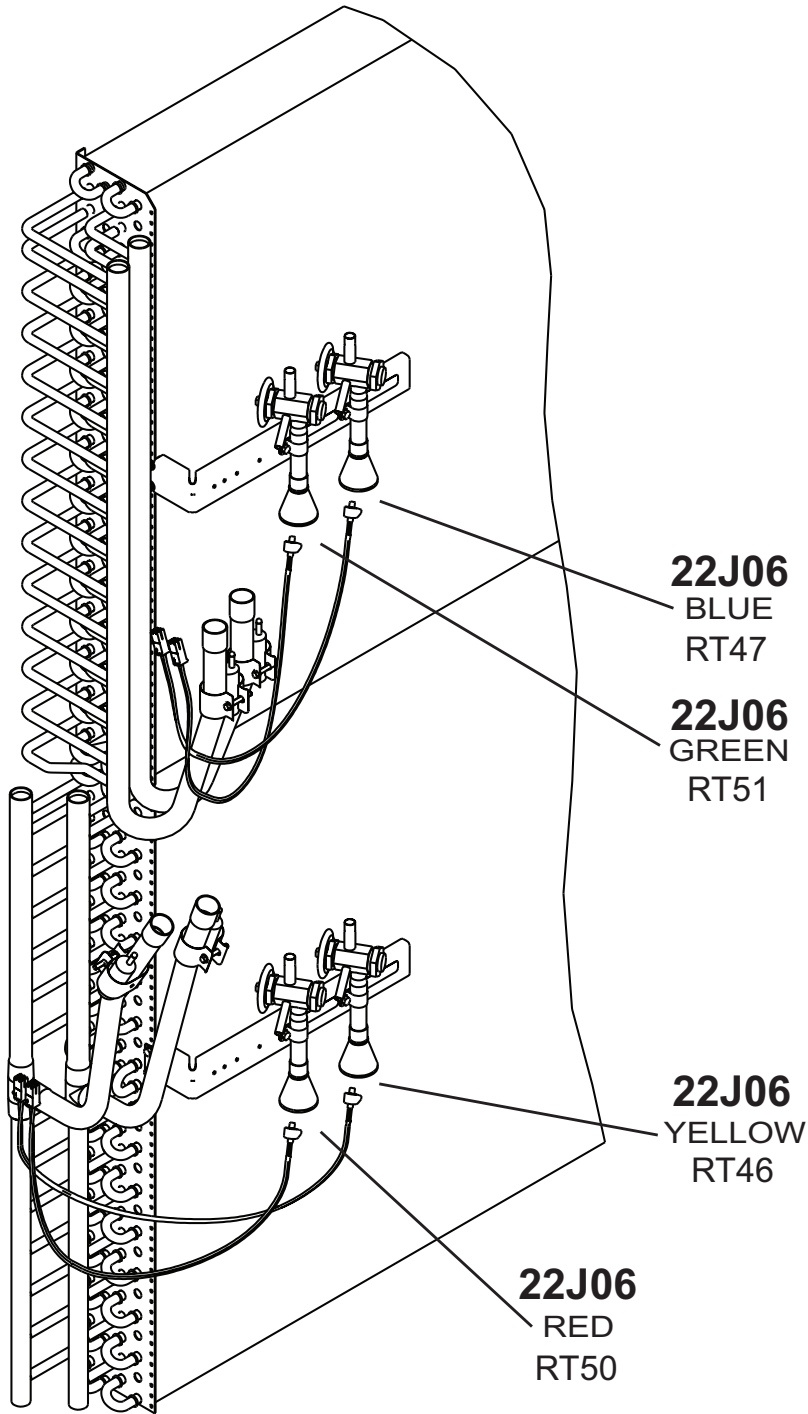
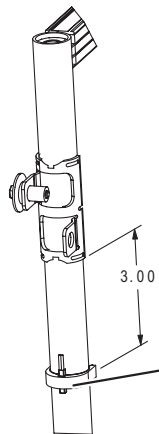
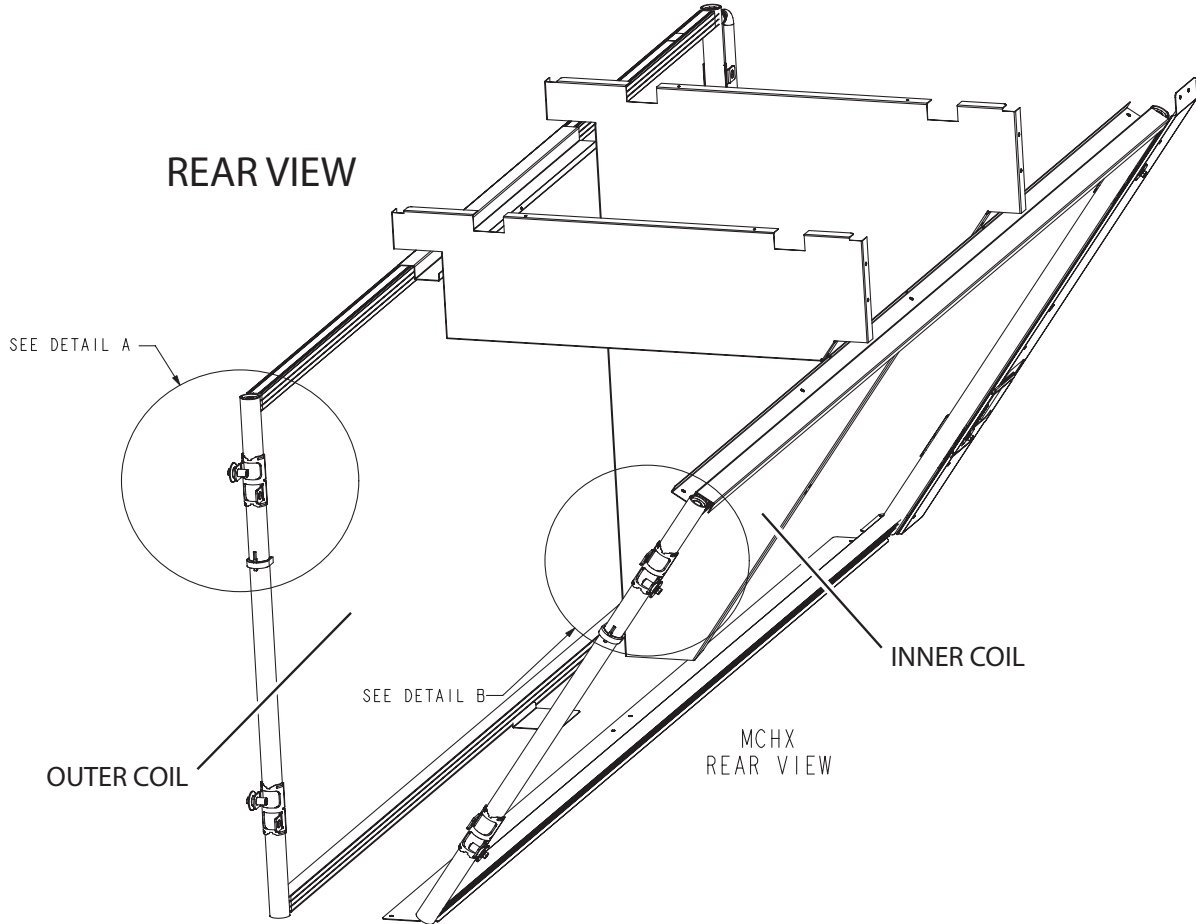

FIGURE 16

LGT/LCT156, SGH/SCH120
CONDENSER / OUTDOOR COIL
(RT48, 49)



23V50
YELLOW
RT48

DETAIL A

23V50
BLUE
RT49

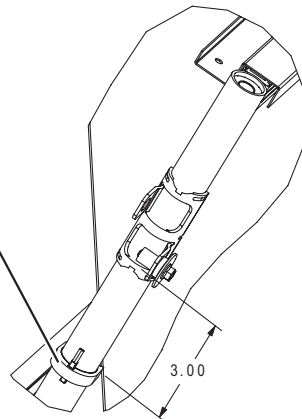

CLAMP THERMISTOR
TO BARE COPPER
ON REAR OF MANIFOLD.

DETAIL B

DETAILS NOT TO SCALE

FIGURE 17

LGT/LCT180
CONDENSER COIL
RT48, 49, 52

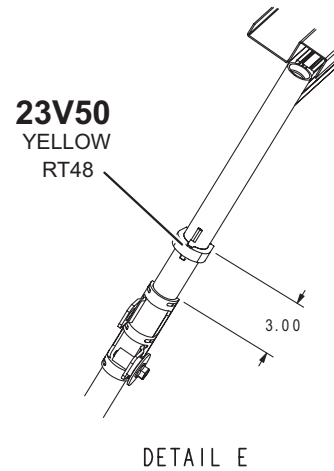
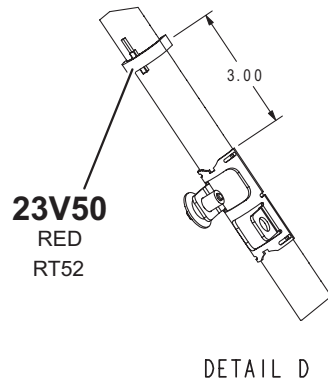
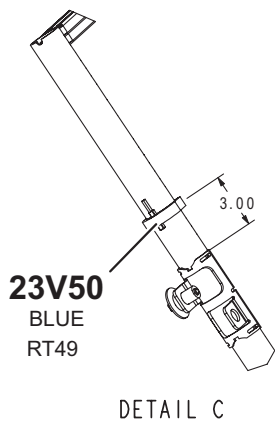
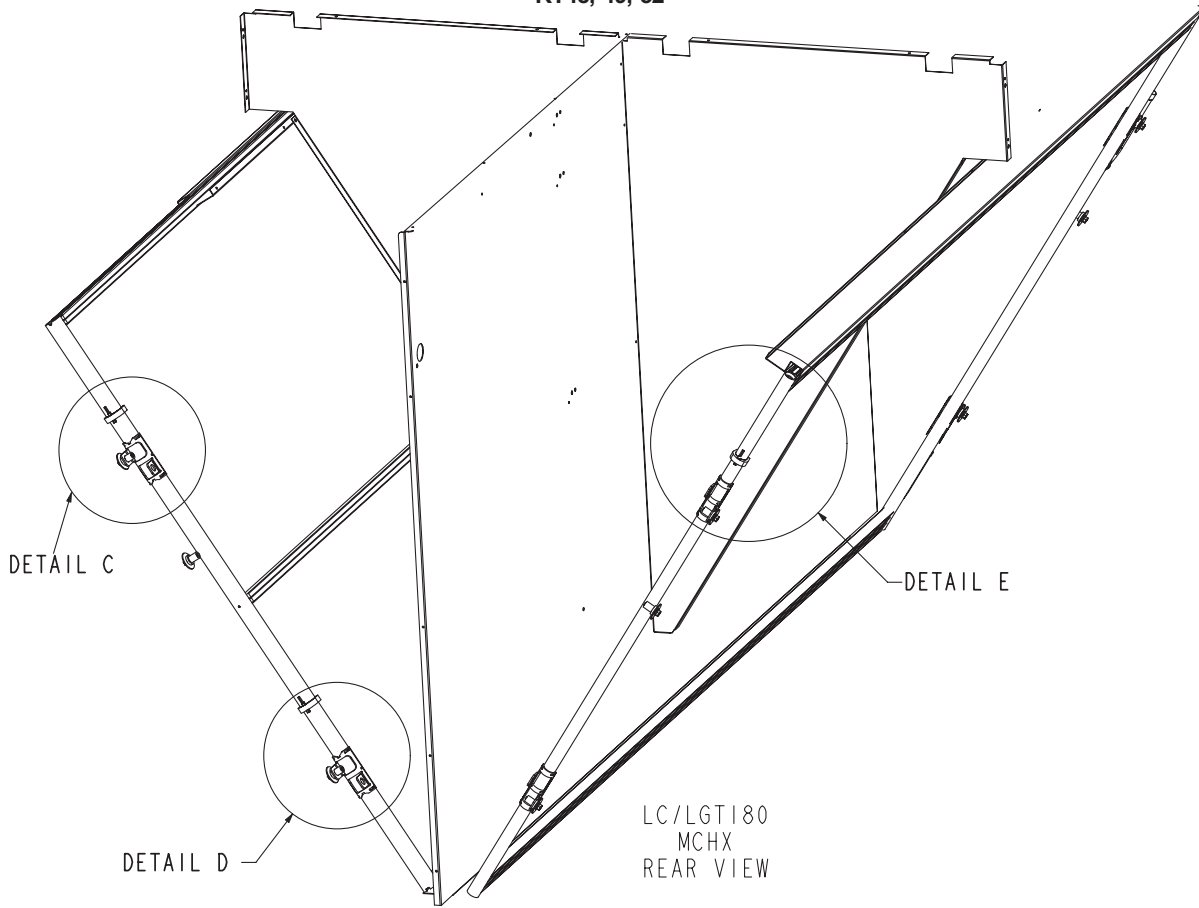

DETAILS NOT TO SCALE

FIGURE 18

LGT/LCT210, 240, 300
CONDENSER COIL
RT48, 49, 52, 53

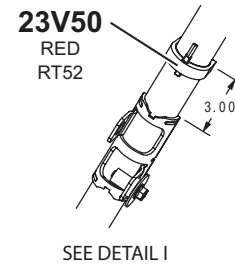
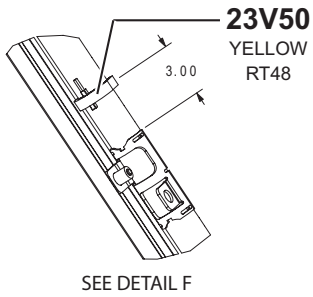
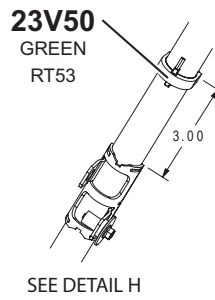
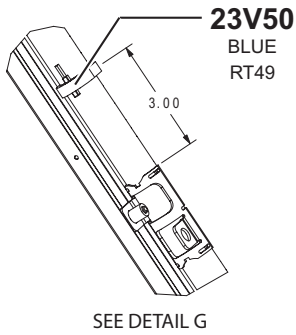
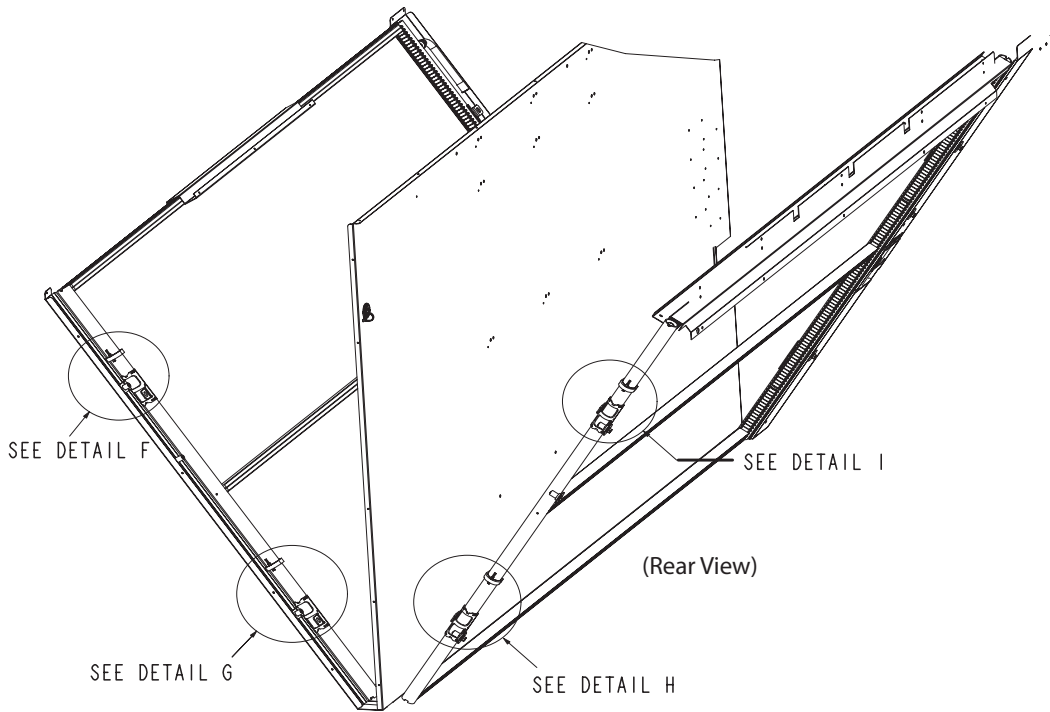

DETAILS NOT TO SCALE

FIGURE 19

LGT/LCT302, 360, SGH/SCH240
 CONDENSER COIL
 RT48, 49, 52, 53

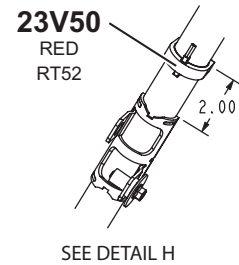
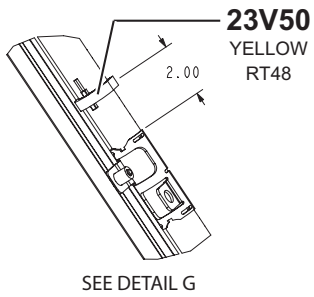
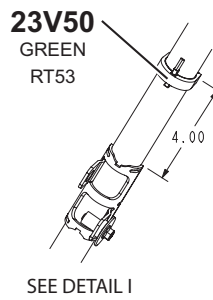
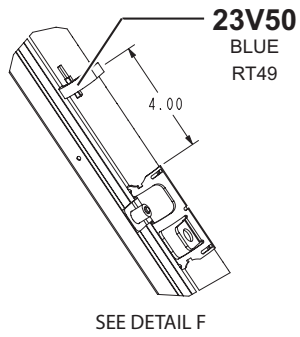
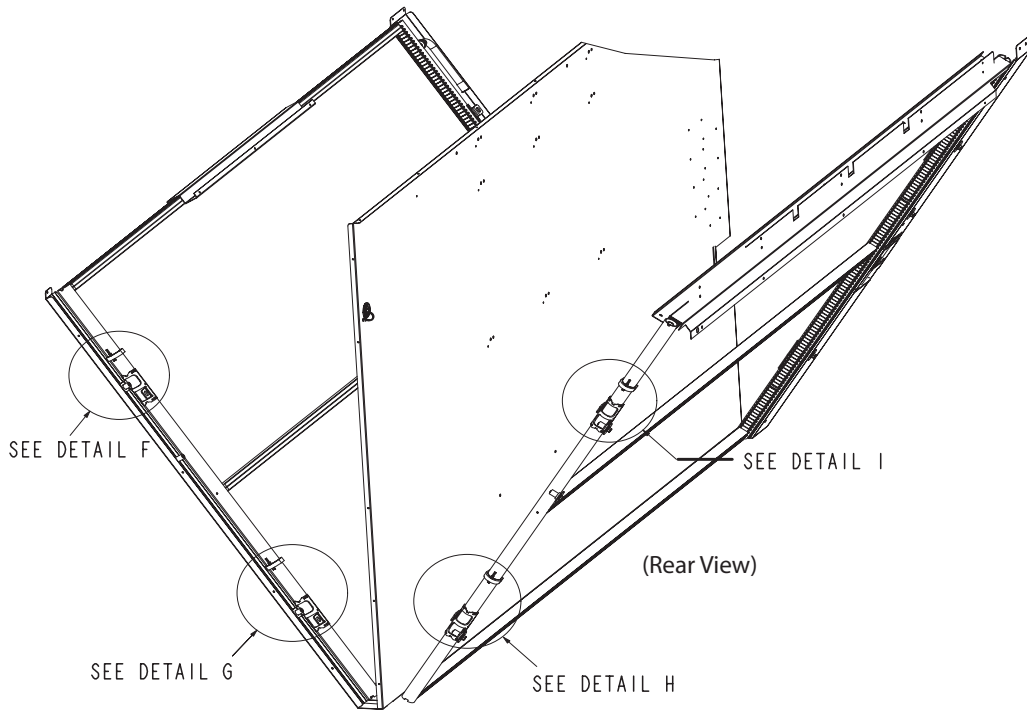

DETAILS NOT TO SCALE

FIGURE 20

LGT/LCT092, 102, 120, 150
 LGX/LCX150
 LHX092, 102, 120
 EVAPORATOR COIL
 RT46, RT47

NOTES:

1. RT46 SENSOR, STAGE 1 DISTRIBUTOR TUBE, ANY TUBE BEFORE THE BLACK DISTRIBUTOR SLEEVE.
2. RT47 SENSOR, STAGE 2 DISTRIBUTOR TUBE, ANY TUBE BEFORE THE BLACK DISTRIBUTOR SLEEVE
3. USE WIRE TIE (ITEM 20) TO SECURE WIRE TO COPPER TUBE FOR STRAIN RELIEF.
4. ATTACH SENSORS SO WIRES ARE ORIENTED IN DOWNWARDS DIRECTION AS SHOWN.

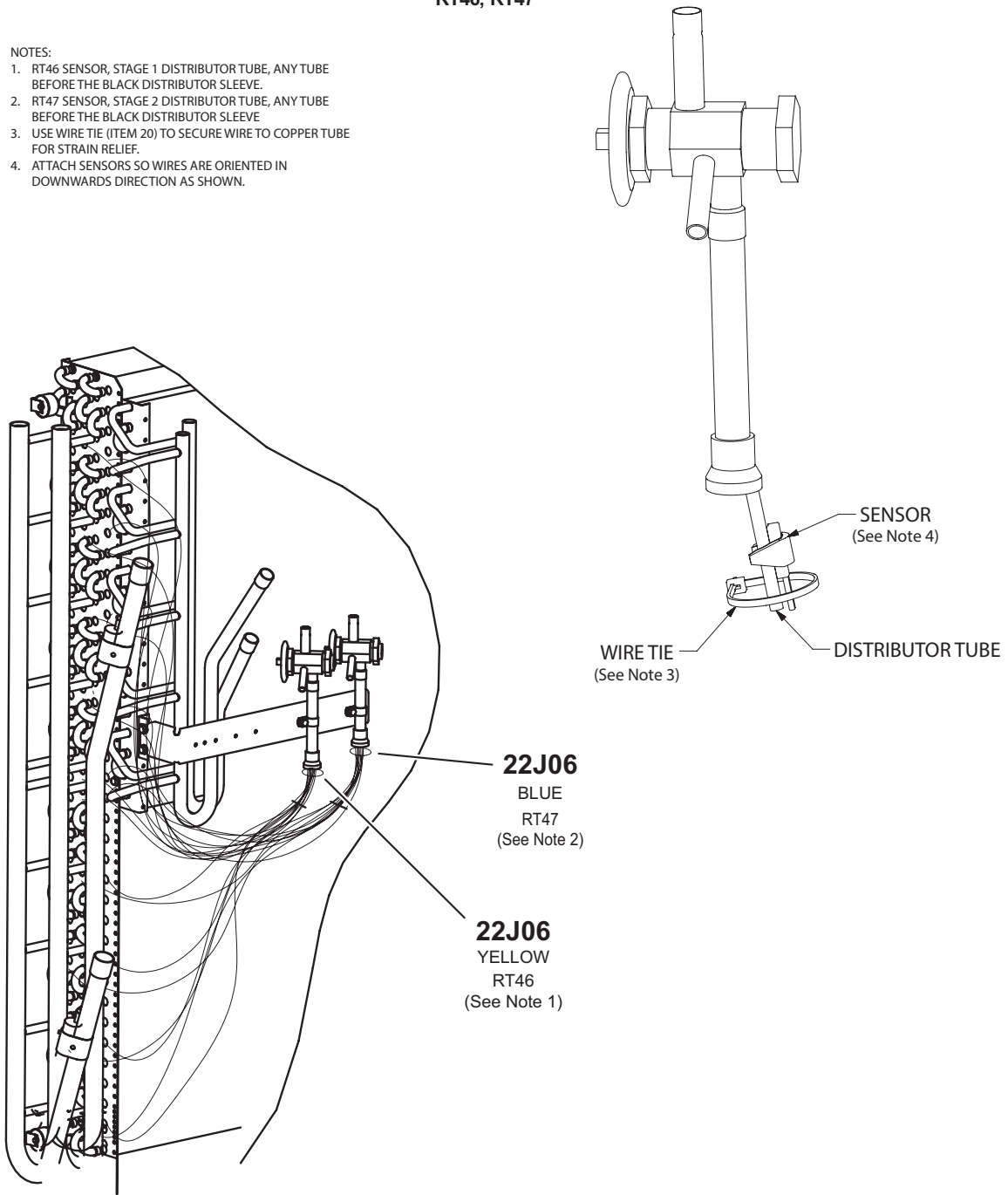

DETAILS NOT TO SCALE

FIGURE 21

LGT/LCT092, 102, 120, 150
CONDENSER COIL
RT48, RT49

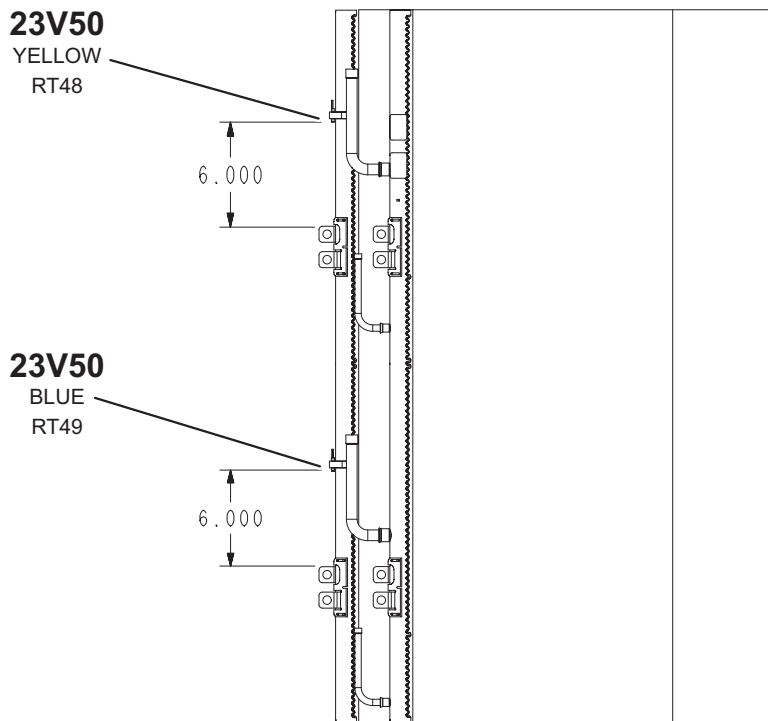
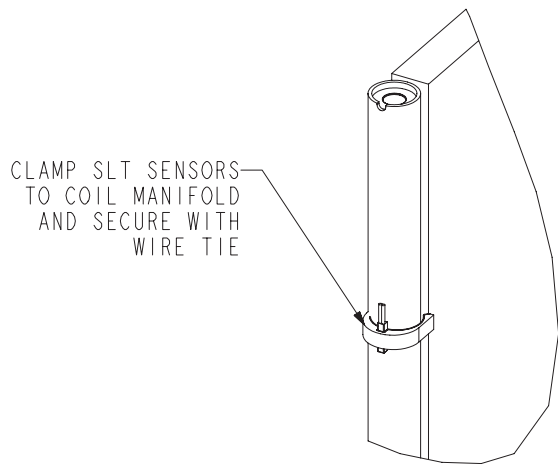

DETAILS NOT TO SCALE

FIGURE 22

LHT/LDT078, 092, 102, 120, 152
EVAPORATOR COIL
RT46, RT47

NOTES:

1. RT46 SENSOR, STAGE 1 DISTRIBUTOR TUBE, ANY TUBE BEFORE THE BLACK DISTRIBUTOR SLEEVE.
2. RT47 SENSOR, STAGE 2 DISTRIBUTOR TUBE, ANY TUBE BEFORE THE BLACK DISTRIBUTOR SLEEVE.
3. USE WIRE TIE (ITEM 03) TO SECURE WIRE TO COPPER TUBE FOR STRAIN RELIEF.
4. ATTACH SENSORS SO WIRES ARE ORIENTED IN DOWNWARDS DIRECTION AS SHOWN.

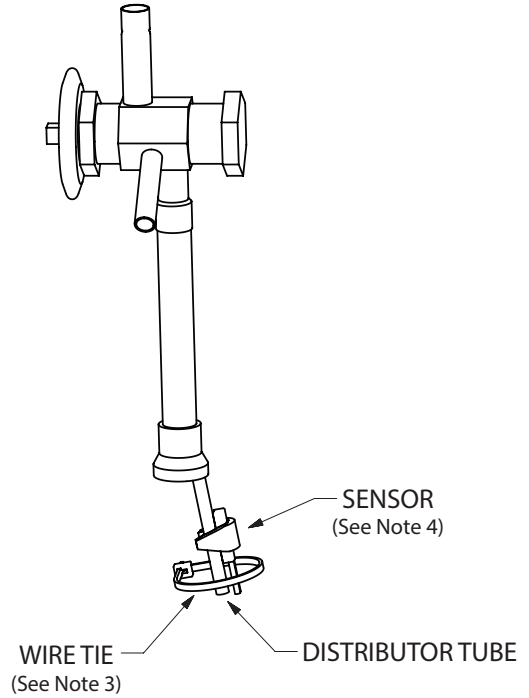
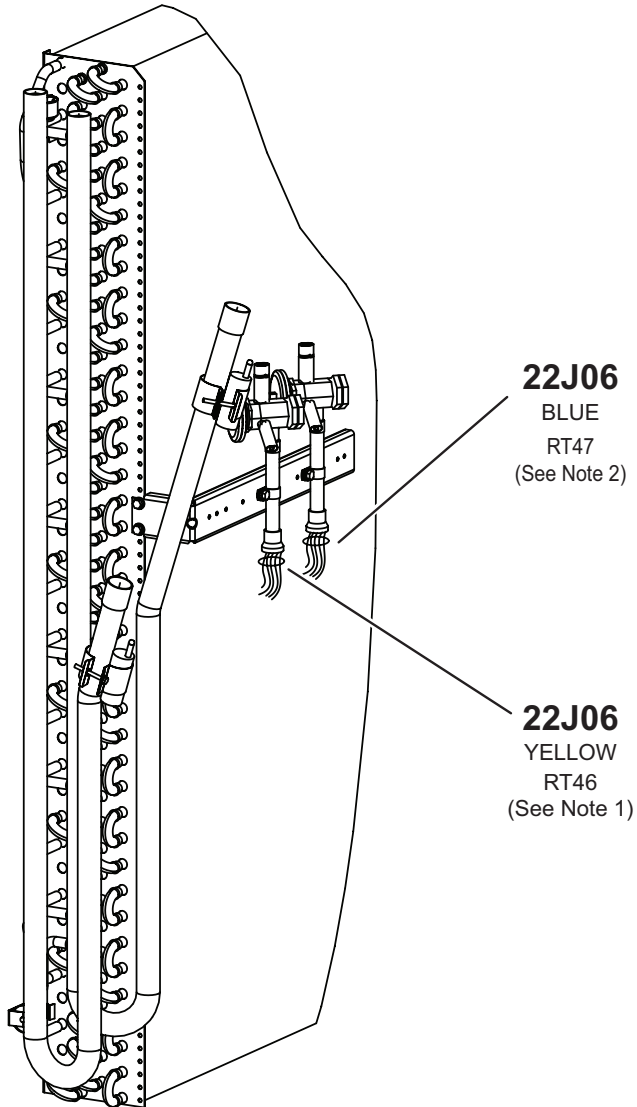

CLAMP THERMISTOR
TO BARE COPPER

DETAILS NOT TO SCALE

FIGURE 23

LHT/LDT078, 092, 102, 120, 152
CONDENSER COIL
RT48, RT49

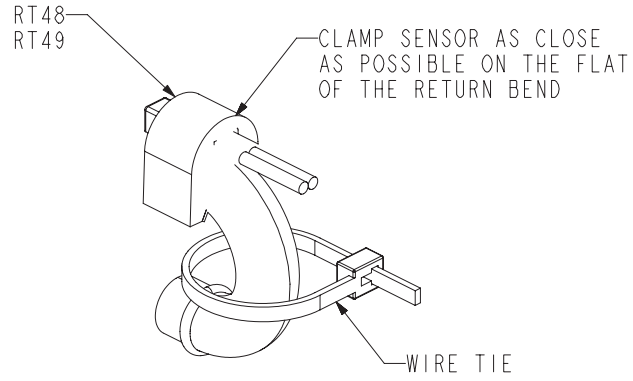

SENSOR DETAIL

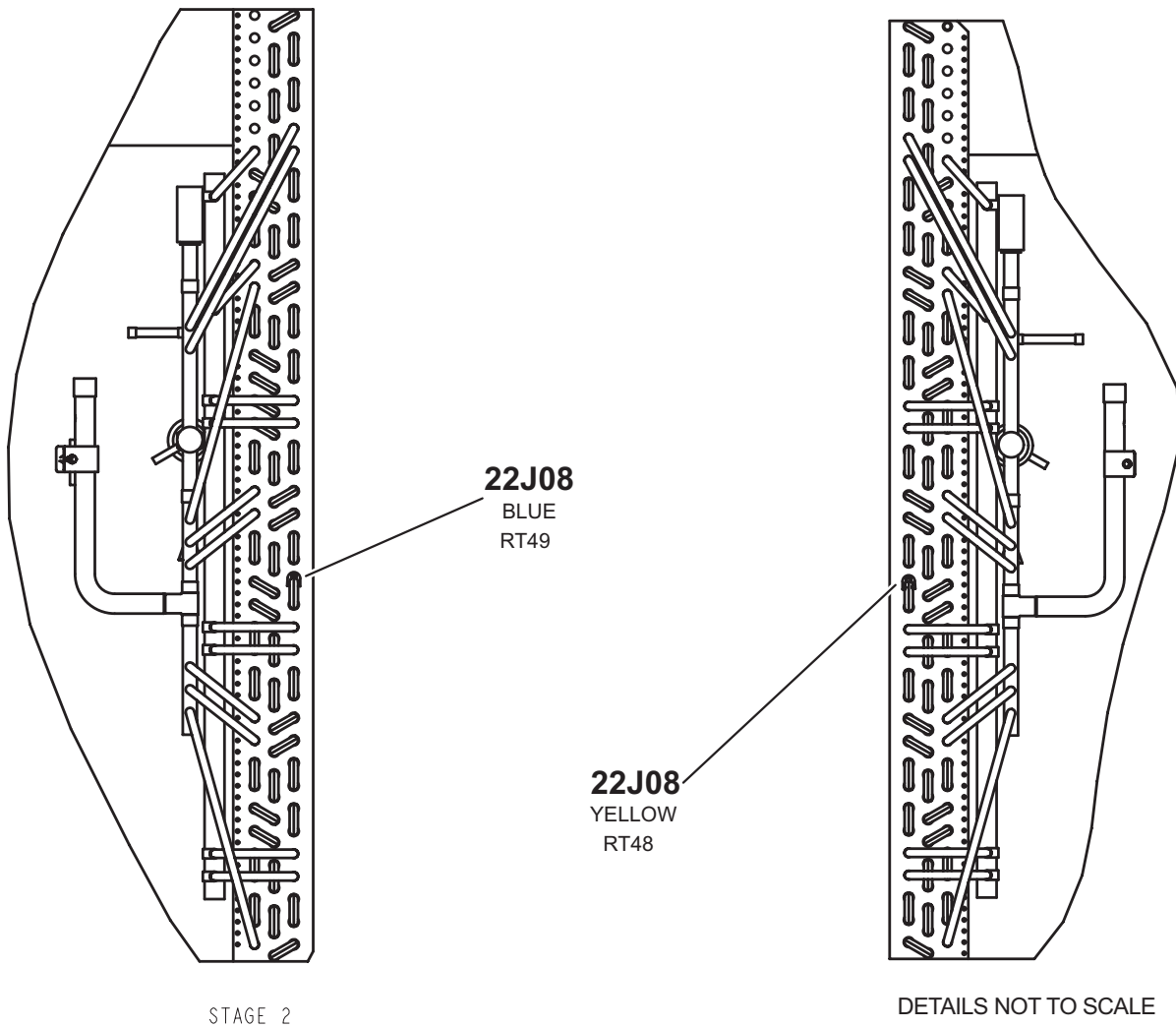

FIGURE 24

LHT/LDT156, 180, 240; LHX180, 240, 300
INDOOR COIL
RT46, RT47

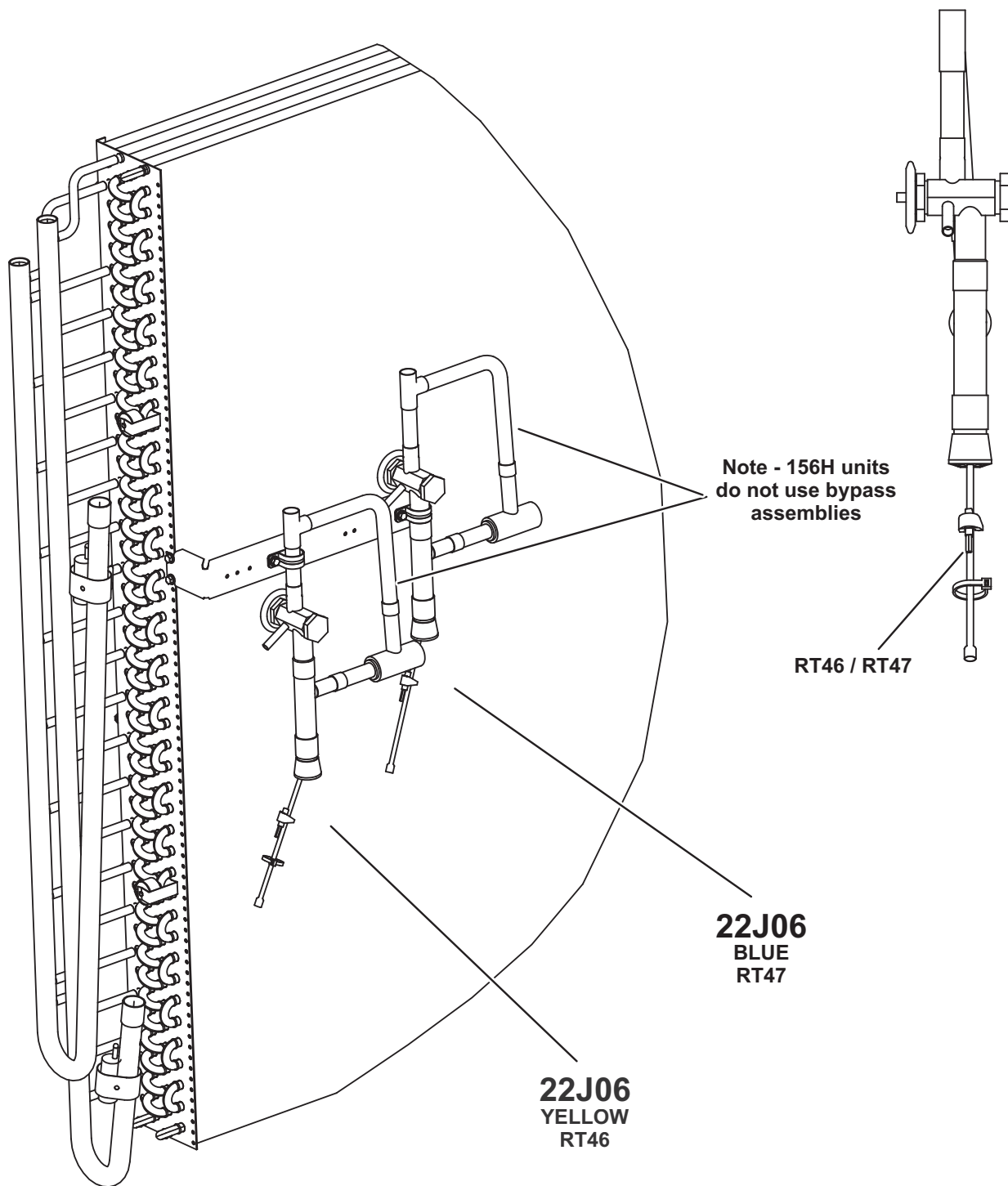

FIGURE 25

LHT/LDT156, 180, 240
OUTDOOR COIL
RT48, RT49

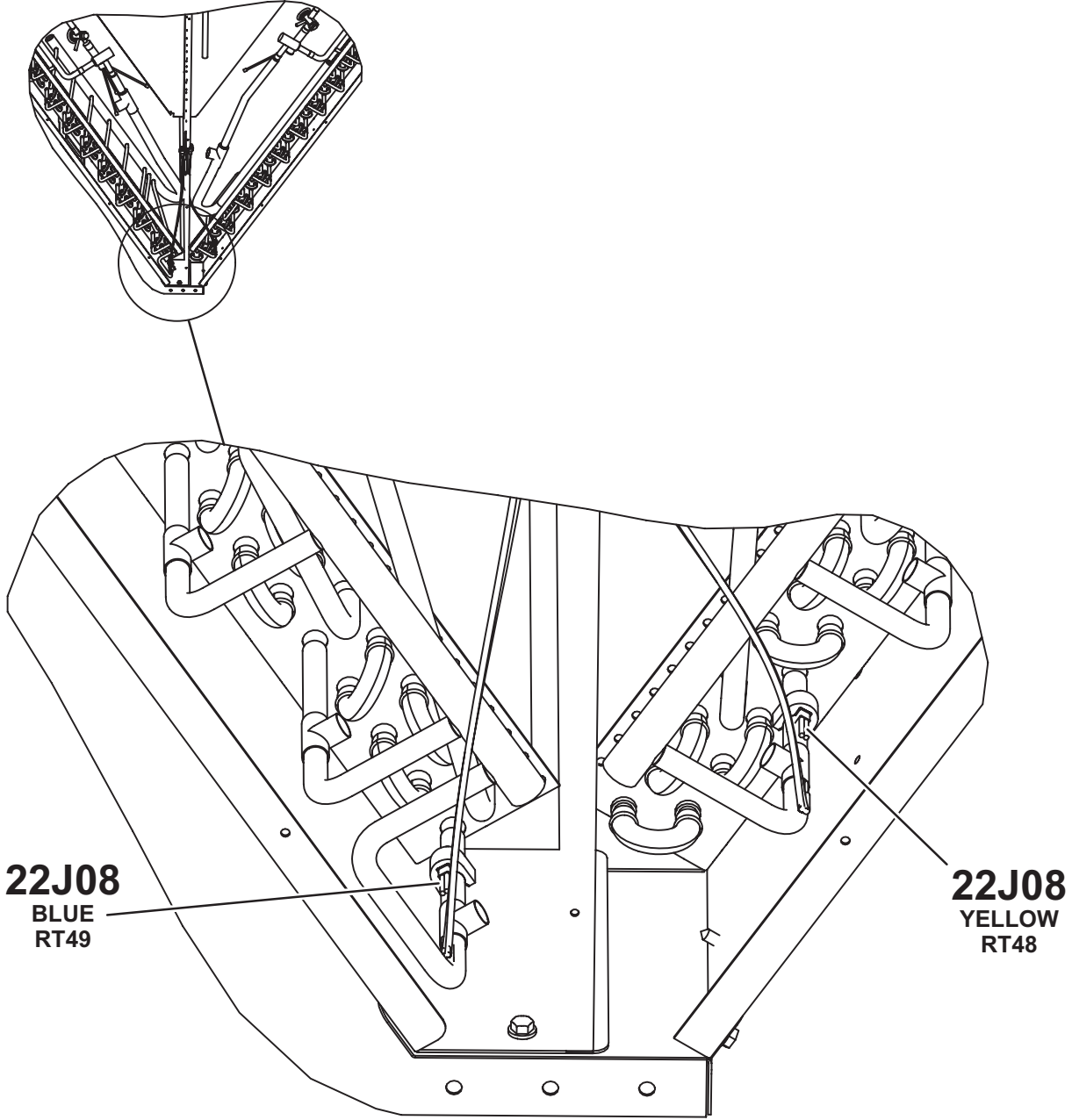

FIGURE 26

LHT/LDT302
INDOOR COIL
RT46, RT47

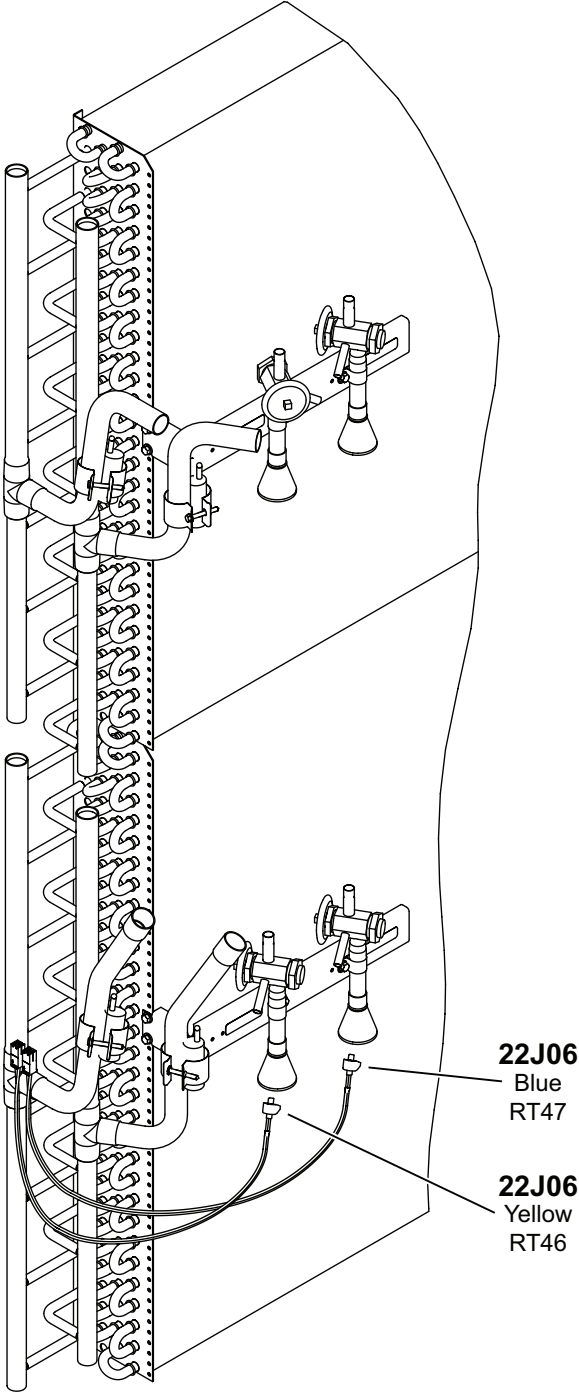

FIGURE 27

LHT/LDT302
OUTDOOR COIL
RT48, RT49

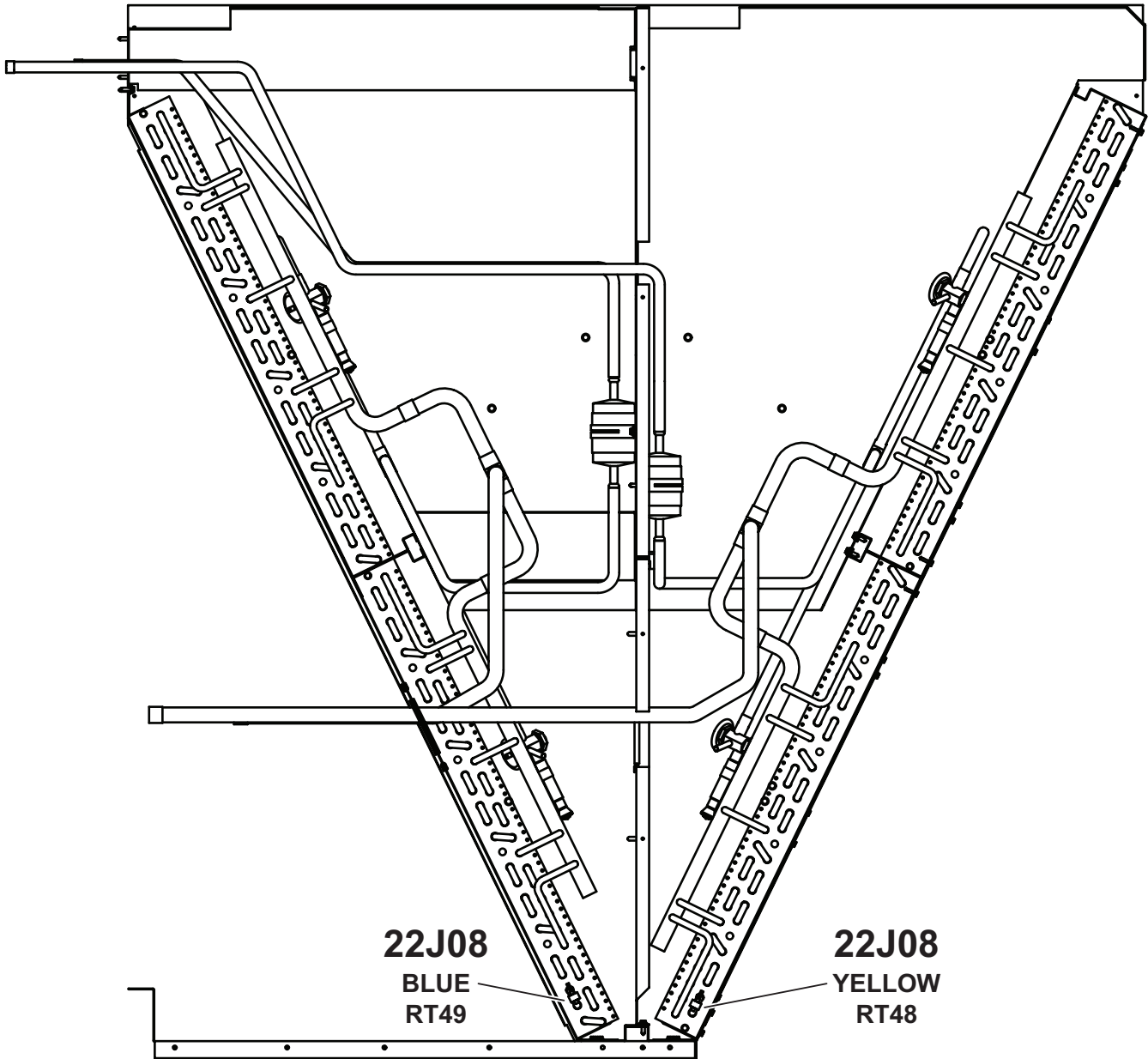

FIGURE 28

LHX180, 240
THERMISTOR LOCATION
OUTDOOR COIL
RT48, RT49

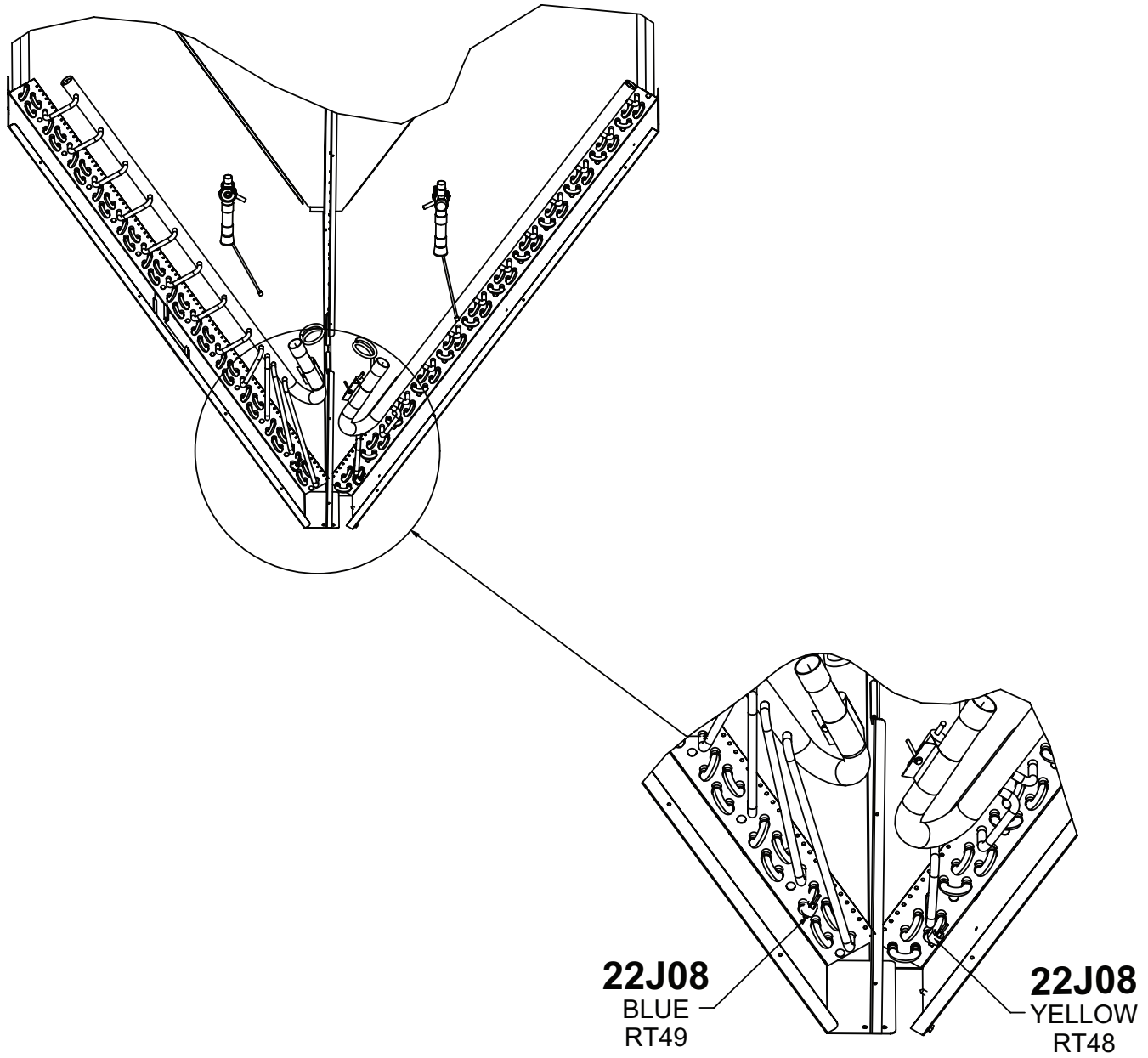
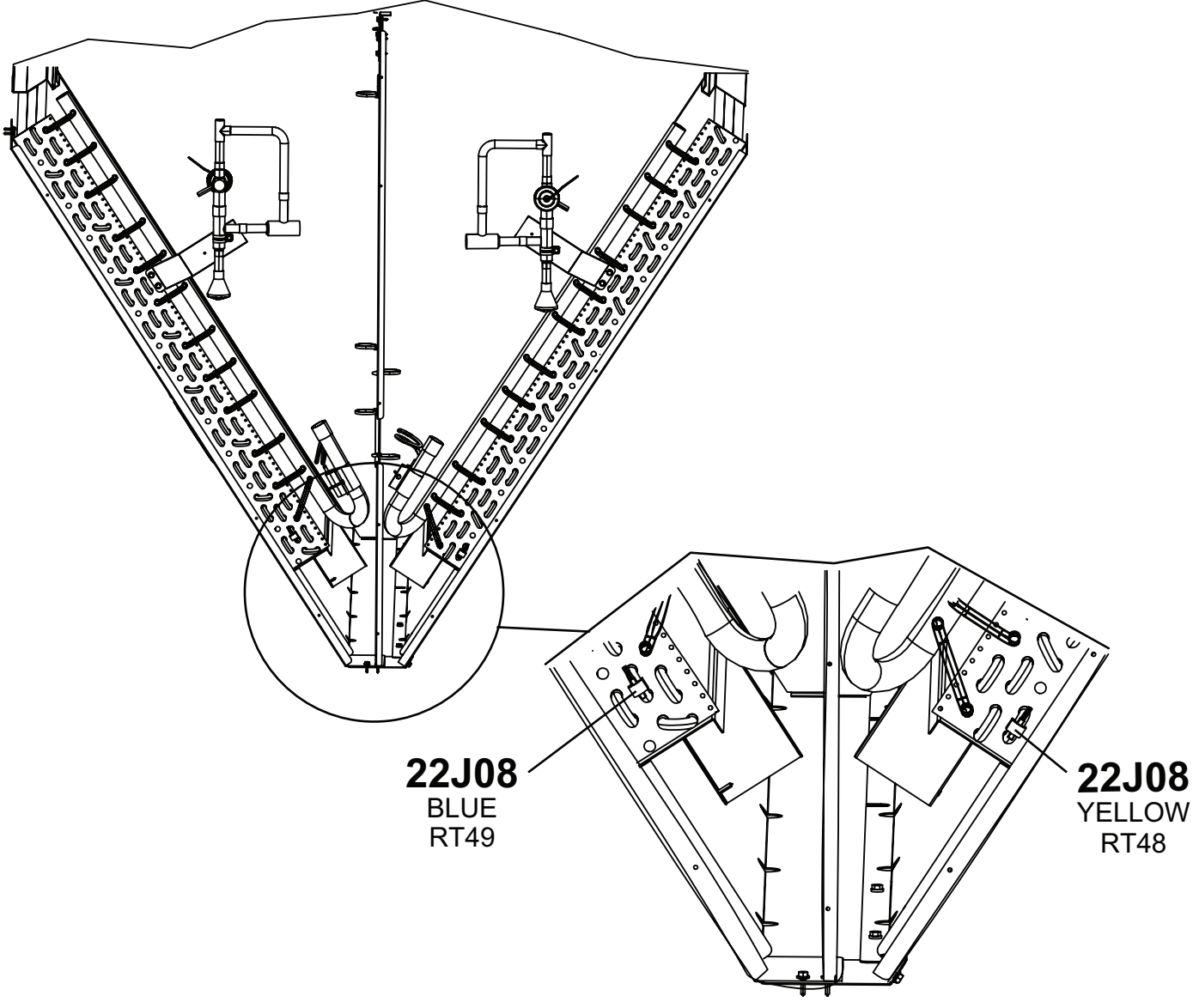

FIGURE 29

LHX300
THERMISTOR LOCATION
OUTDOOR COIL
RT48, RT49



22J08
BLUE
RT49

22J08
YELLOW
RT48

FIGURE 30

**LGX/LCX 092, 102, 120
EVAPORATOR COIL
RT46, RT47**

NOTES:

1. RT46 SENSOR, STAGE 1 DISTRIBUTOR TUBE, ANY TUBE BEFORE THE BLACK DISTRIBUTOR SLEEVE.
2. RT47 SENSOR, STAGE 2 DISTRIBUTOR TUBE, ANY TUBE BEFORE THE BLACK DISTRIBUTOR SLEEVE
3. USE WIRE TIE (ITEM 25) TO SECURE WIRE TO COPPER TUBE FOR STRAIN RELIEF.
4. ATTACH SENSORS SO WIRES ARE ORIENTED IN DOWNWARDS DIRECTION AS SHOWN.

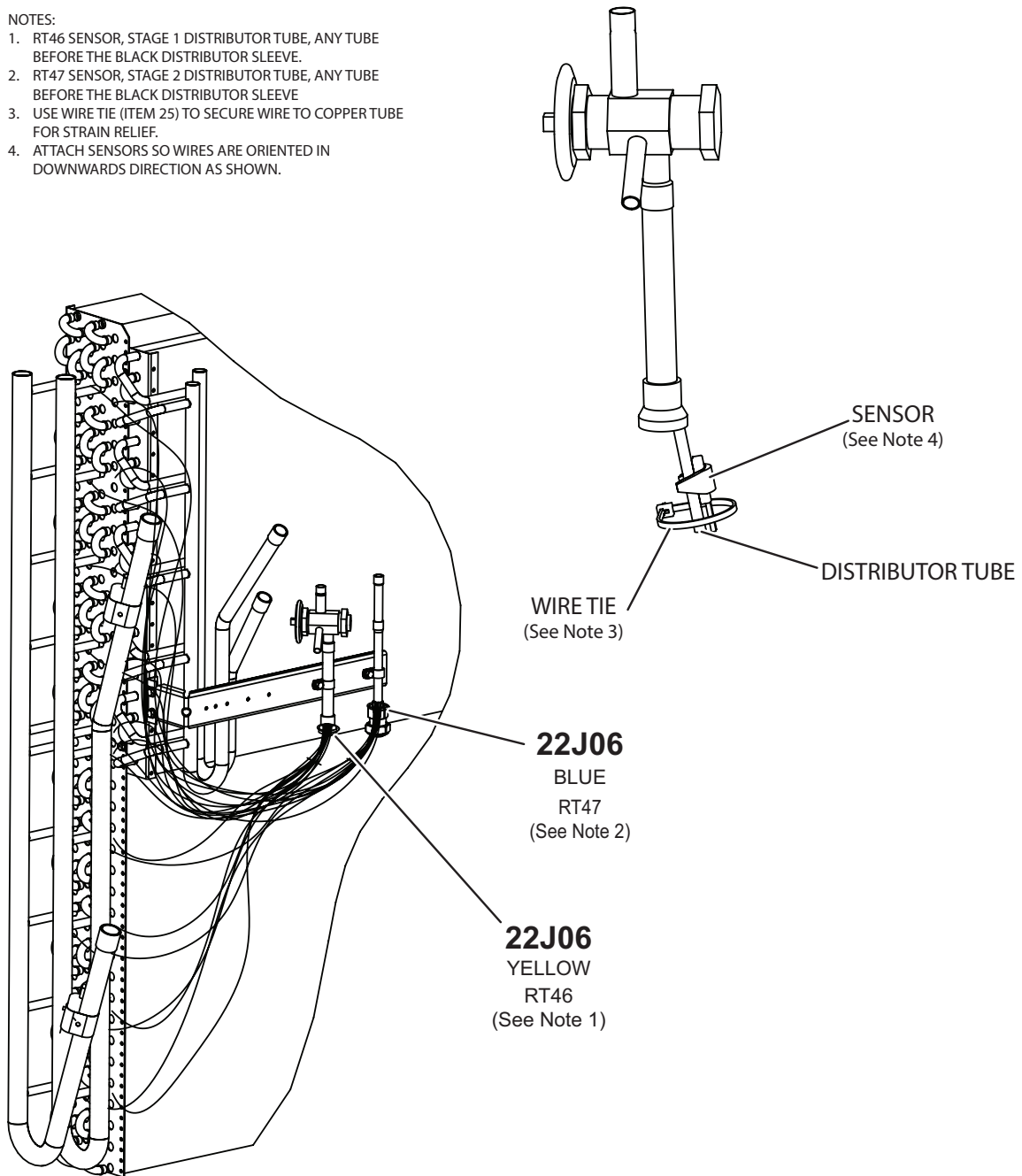
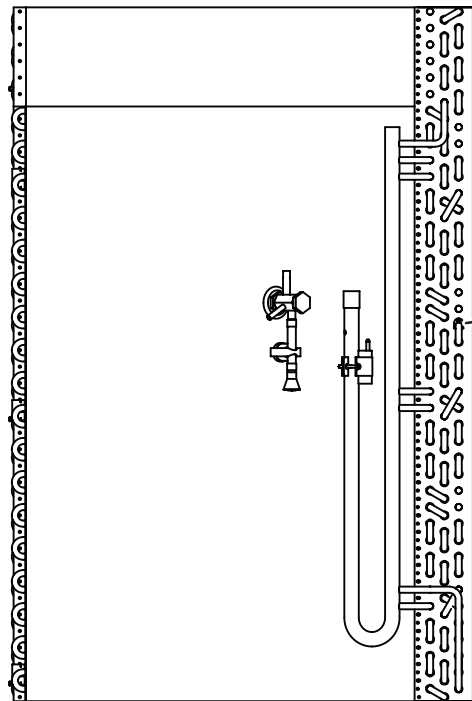

FIGURE 31

LHX092, 102, 120
CONDENSER COIL
RT48, RT49



STAGE 2

22J08

BLUE
RT49
(See Notes 2,
3, 4, 5)

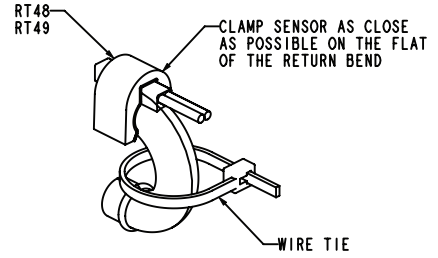

SENSOR DETAIL

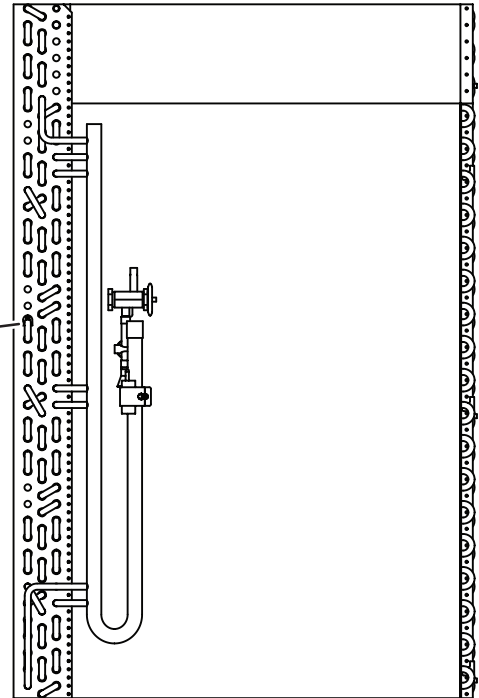

STAGE 1

22J08

YELLOW
RT48
(See Notes 1,
3, 4, 5)

NOTES:

1. RT48 SENSOR, STAGE 1
2. RT49 SENSOR, STAGE 2
3. APPLY SILICONE GREASE (ITEM 29) UNDER RT48,RT49 (ITEMS 27 AND 28) BEFORE ATTACHING THE SENSOR TO THE COPPER TUBE
4. USE WIRE TIE (ITEM 05) TO SECURE WIRE TO COPPER TUBE FOR STRAIN RELIEF.
5. ATTACH SENSORS SO WIRES ARE ORIENTED IN "DOWNWARDS" DIRECTION (SHOWN)

DETAILS NOT TO SCALE

FIGURE 32