

EL180UHN(E)K

ELITE® SERIES

Upflow / Horizontal | Constant Torque Blower | Refrigerant Detection | 60Hz



RESIDENTIAL
PRODUCT SPECIFICATIONS (EHB)

AFUE - 80%

Meets NOx Limit of 14 ng/J

Input - 40,000 to 100,000 Btuh

Nominal Add-on Cooling - 1.5 to 5 Tons

ELITE®
SERIES



MODEL NUMBER IDENTIFICATION

EL 1 80 UH 080 N E 48 B K

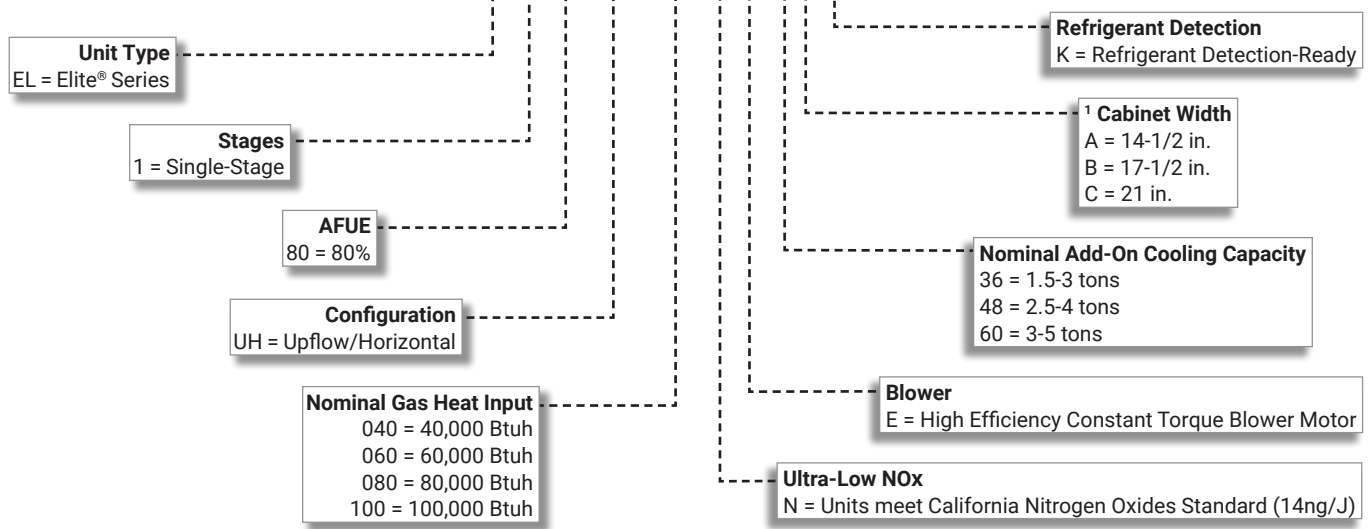

¹ Indoor coils with the same letter designation will physically match the furnace.

FEATURE HIGHLIGHTS

1. Heat Exchanger Assembly
2. Burner Orifice/Air Intake Assembly
3. SureLight® Hot Surface Ignitor
4. Modulating Gas Control Valve
5. Variable-Speed Combustion Air Inducer
6. Thermal Switch
7. Variable Speed Direct Drive Blower
8. SureLight® Integrated Furnace Control
9. Insulated Cabinet
10. Safety Interlock Switch
11. Gas Piping And Electrical Inlets

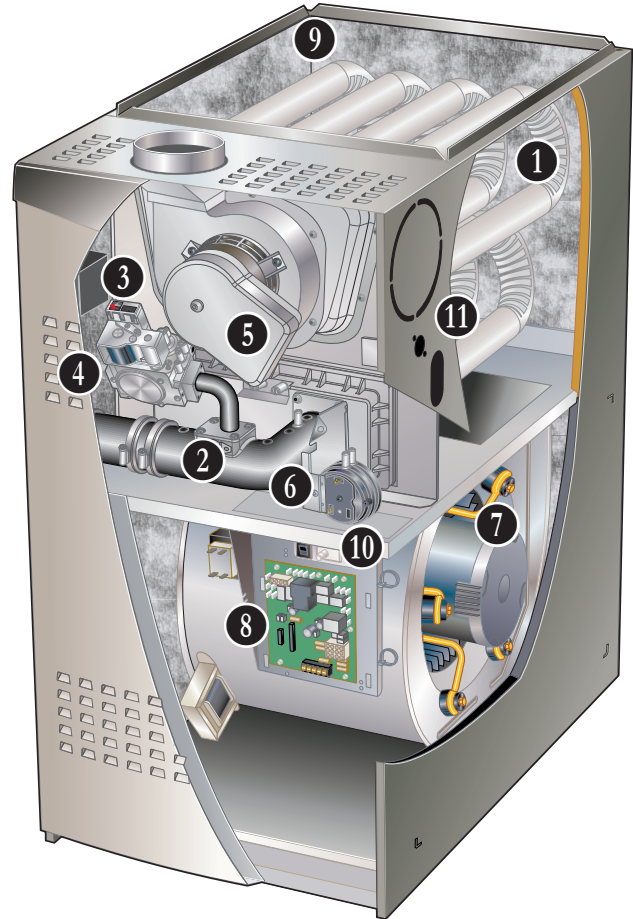

NOTE - EL180UHNE FURNACES ARE NATURAL GAS ONLY!
NOTE - EL180UHNE FURNACES ARE NOT AVAILABLE IN CANADA!
NOTE - NOT AVAILABLE IN ALL AREAS!
CONTACT YOUR NEAREST LENNOX SALES OFFICE FOR DETAILS.

CONTENTS

Blower Data	16
Approvals And Warranty	3
Control Options	8
Dimensions	12
- Furnace/Coil Combined Dimensions	15
- Optional Accessories	14
- Unit - Horizontal Position	13
- Unit - Upflow Position	12
Features	3
High Altitude Operation.	10
Indoor Air Quality Product Options	7
Installation Clearances	10
Model Number Identification.	1
Optional Accessories - Order Separately	11
Specifications	11

APPROVALS AND WARRANTY

APPROVALS

- AHRI Certified
- Tested and rated according to US DOE test procedures and FTC labeling regulations
- Approved by the California Energy Commission and meets California Nitrogen Oxides Standard (NOx) limits of 14 ng/J
- Units are approved for installations from 0-7500 ft. with no modification.
- ISO 9001 Registered Manufacturing Quality System
- Blower data from unit tests conducted in Lennox Laboratory air test chamber
- All models meet UL 60335-2-40 Refrigerant Detector Requirements

NOTE - This furnace has not been CSA International design certified for installation in mobile homes, recreational vehicles, or outdoors.

California Only

- These furnaces **meet** the South Coast Air Quality Management District (SCAQMD) Rule 1111 and San Joaquin Valley Air Pollution Control District (SJVAPCD) Rule 4905 NOx emission limit (14 ng/J) and can be installed within the SCAQMD, SJVAPCD and Bay area

WARRANTY

- Heat Exchanger:
 - Limited twenty years in residential applications
 - Limited ten years in non-residential applications
- All other covered components:
 - Limited five years in residential installations
 - Limited one year in non-residential installations

FEATURES

APPLICATIONS

- Input capacities of 40,000, 60,000, 80,000 and 100,000 Btuh
- Energy efficiency (AFUE) - 80%
- Compact cabinet for upflow, horizontal-left or horizontal-right applications
- Utility room, alcove, closet, crawl space, basement or attic installation
- Lennox add-on indoor coils, high-efficiency air cleaners and humidifiers can easily be added to furnace
- Shipped factory assembled with all controls installed and wired
- Ready for installation in upflow or horizontal position without any modifications
- Removable bottom seal panel shipped in place for side return air is easily removed for bottom/end return air applications
- Each unit factory test operated to ensure proper operation

HEATING SYSTEM

NOTE - Units Are Natural Gas Only!

1

Heat Exchanger Assembly

- Heavy gauge aluminized steel heat exchanger
- Tubular type design
- Designed for normal expansion and contraction
- Round surfaces create minimum resistance to air flow for excellent heat transfer
- Heat exchanger has been laboratory life cycle tested in excess of industry standards
- Compact size of heat exchanger permits low overall design of furnace cabinet

2

Burner Orifice/Air Intake Assembly

- Burner assembly has a single orifice located between the gas valve and the air intake assembly
- Orifice is precisely matched to the burner input
- Burner can be removed for servicing

NOTE - Air Intake Termination is only available on the bottom of the cabinet with horizontal left-hand air discharge.
Air Intake Pipe must be FIRMLY secured in this position to prevent disconnection!

3

SureLight® Hot Surface Ignitor

- Tough, reliable, long-life, trouble-free performance
- Silicon nitride ignitor
- Cemented to steatite block for protection against current leakage
- Ignition leads are constructed of nickel plated copper and are enclosed in high temperature Teflon® insulation for dependable operation

4

Modulating Gas Control Valve

- 24 volt redundant combination modulating gas control valve combines manual shut off switch (On-Off), automatic electric valve (dual) and gas pressure regulation into a compact combination control

5

Variable-Speed Combustion Air Inducer

- Heavy duty variable-speed blower prepurges heat exchanger and safely vents flue products
- Pressure switch proves blower operation before allowing gas valve to open
- Operates only during heating cycle

FEATURES

HEATING SYSTEM (continued)

Air Intake Pipe Assembly (REQUIRED)

- Furnished for field installation outside the conditioned air stream
- Adds 4-1/2 in. (114 mm) to furnace width
- Consists of: (1) 2 in. PVC elbow, (1) PVC 3 x 2 in. reducer, (1) 2 in. PVC pipe and Inlet screen
- Assembly must be mounted on the left side of cabinet in upflow applications, see dimension drawings
- Assembly must be mounted above the cabinet in horizontal right-hand air discharge applications and below the cabinet in left-hand air discharge applications, see dimension drawings
- See installation instructions for additional information
- Assembly may be rotated if necessary to accommodate furnace installation

6 Thermal Switch

- Factory installed on air/fuel intake assembly
- Automatic reset
- Switch provides protection from abnormal operating conditions

Limit Control

- Primary limit is accurately located on vestibule panel on all units
- Automatic reset

Optional Accessories

Low Profile Air Intake Pipe Kit

- Replaces the required Air Intake Pipe Assembly furnished for reduced clearances in confined spaces
- Adds 2-3/4 in. (70 mm) to furnace width
- Consists of: (1) 2 in. PVC street elbow, (1) 2 in. PVC sweep elbow, (1) 2 in. PVC pipe and Inlet screen
- Intake air orifices are furnished for each size furnace
- Assembly must be mounted on the left side of cabinet in upflow applications
- Assembly must be mounted above the cabinet in horizontal right-hand air discharge applications and below the cabinet in left-hand air discharge applications
- Street and sweep elbows may be swiveled independently to different positions if necessary to accommodate furnace installation
- See kit installation instructions for additional information

Vent Adaptor (Upflow Applications Only)

- Allows venting through a masonry chimney without the need of a flue liner
- Manual reset temperature sensor protects against abnormal operating conditions
- Sensor wiring may be routed from either side of adaptor
- Minimum winter design temperatures:
 - -10°F when used with interior masonry chimneys
 - +5°F when used with exterior masonry chimneys

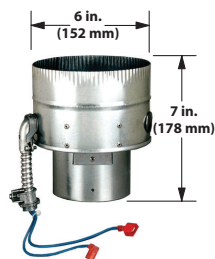

NOTE - Refer to Winter Design Temperatures Map on page 10 for application information. Also refer to the installation instructions for detailed information.

Combustion Air Intake Muffler Kit

- Significantly reduces outdoor operating sound levels
- Installed vertically or horizontally in the intake piping
- See Optional Accessories Dimension Drawing

BLOWER

- Direct drive blower
- Statically and dynamically balanced
- Resiliently mounted
- Blower assembly easily removed for servicing

7 Power Saver™ Constant Torque Blower Motor

- DC Brushless Motor
- High Efficiency Constant Torque
- ECM (Electronically Commutated Motor)
- Motor is programmed to provide constant torque at each of the selectable speeds
- Motor is controlled by the Integrated Furnace Control
- Blower speeds are easily changed on the integrated furnace control
- See blower performance tables

CONTROLS

8 SureLight® Integrated Furnace Control

- Contains all necessary controls and relays to operate furnace
- Combustion air inducer is operated by the integrated furnace control. Prior to ignition, a pre-purge cycle for 15 seconds is initiated
- After the main burners are turned off, a post-purge cycle for 5 seconds is run
- Flame sensor assures safe and reliable operation
- Should loss of flame occur, the integrated furnace control will initiate 4 re-attempts at ignition before locking out unit operation for 60 minutes
- Watchguard type circuit automatically resets ignition controls after one hour of continuous thermostat demand after unit lockout, eliminating nuisance calls for service
- Display LED - Seven segment LED displays numeric information related to diagnostics as well as system operation and status
 - Diagnostic codes are held in non-volatile memory, immune from power interruptions
 - Holds up to ten diagnostic codes in order of occurrence for recall on demand
 - Port on blower door allows for easy viewing
- Fan control consists of adjustable blower timed-off delay (60, 90, 120, 180 seconds - factory setting 120 seconds) and fixed blower timed-on delay (30 seconds heating, 2 seconds cooling)

FEATURES

CONTROLS (continued)

- For air-conditioning applications, blower is automatically energized on thermostat demand for cooling
- Two accessory terminals furnished for additional power supply requirements for 120 volt (less than 1 amp) power humidifiers and powered air cleaners
- One additional terminal is furnished for power supply requirements for 24V (less than 0.5 amp) low voltage accessories
- Ignition control has a single red LED to indicate status

Twinning

- Terminal furnished on furnace control for twinning two furnaces together

24 Volt Transformer (40VA)

- Furnished and factory installed on outside of control box
- Circuit breaker (furnished) is wired in series

Field Wiring Make-Up Box

- Furnished for line voltage wiring
- Factory installed internally on left side of furnace
- Box may be installed internally on right side of furnace

Refrigeration Detection System (RDS)

(Part of the SureLight® Integrated Furnace Control)

- Complies with UL 60335-2-40 approved standard
- Required for all systems using R-454B refrigerant
- Plug-in connection to the RDS Coil Sensor
- Supports up to two RDS Coil Sensors (factory setting)
- Used as an interface between indoor unit and thermostat to control system
- Ensures safe operation for systems equipped with R-454B refrigerant
- If R-454B refrigerant is detected, the refrigerant detection system will stop compressor and/or heating operation and operate the blower to reduce concentrations in the conditioned space
- Once safe levels are reached the HVAC system will resume normal operation
- Low GWP test button for troubleshooting
- Alarm/Zone relay interface can trigger an external alarm if R-454B refrigerant is detected and open all zone dampers (if part of a zoning system) if R-454B refrigerant is detected
- Power is disabled to non-communicating thermostats to prevent demand if R-454B refrigerant is detected
- On system start-up blower will run for five minutes and any thermostat demands are disabled

Optional Accessories

Thermostat

- Thermostat is not furnished with unit
- See page 7

Blower Relay Kit

(For Use With Two-Stage Outdoor Units)

- Allows furnace blower speed changes when matched with two-stage air conditioners or heat pumps

Transformer (75VA)

- Recommended when furnace is used with zoning or dual-fuel systems and other 24V accessories requiring a higher VA rating
- Circuit breaker (furnished) is wired in series
- Replaces the standard 40VA transformer

FILTER (not furnished)

- Filter and provisions for external mounting must be field provided

Optional Accessories

Air Filter and Rack Kit for Horizontal Return Air (End) Applications

- Washable or vacuum cleanable polyurethane frame type filter and external end return air rack
- Rack has filter door for servicing
- Flanges on rack for duct connection
- Field installed
- See dimension drawing

Air Filter and Rack Kit for Upflow Side Return Air

NOTE - Not for use with Return Air Base

- Washable or vacuum cleanable polyurethane frame type filter and external side return air rack available for field installation
- Available in single and ten pack kits
- Rack has filter door for servicing
- Flanges on rack for duct connection
- Field installs on either side of unit cabinet
- See dimension drawing

FEATURES

CABINET

NOTE - Flue outlet is on top of the cabinet only!
In the upflow position the flue must be vented vertically.
In the horizontal position the flue must be vented vertically immediately after exiting the cabinet!

- Low-profile, narrow width cabinet allows easy installation
- Heavy-gauge, cold rolled steel construction
- Pre-painted cabinet finish
- Flanges provided on supply air opening for ease of plenum connection or alignment with indoor coil
- 9 • Insulated cabinet with foil faced insulation on sides and back of heating compartment and mat faced insulation in blower compartment
- Sealed blower compartment
- Inner blower compartment access panel seals blower compartment from air leakage
- Cabinet door can be removed without any tools
- Complete service access
- 10 • Safety interlock switch automatically shuts off power to unit when blower compartment access panel is removed
- 11 • Gas piping and electrical inlets are provided in both sides of cabinet on "B" and "C" width models.

NOTE - Gas piping is only available on the left side of the cabinet on "A" width models.

Bottom/Side Return Air Entry:

- Upflow/horizontal with bottom return air entry:
 - Remove furnished bottom seal panel from cabinet
- Upflow only with side return-air entry ("B" and "C" width cabinets only):
 - Corners are marked on either side of cabinet for return air cut-out
- See dimension drawings

NOTE - 60C size units that require air volumes over 1800 cfm must have one of the following:

- Single side return air and Optional Return Air Base with transition that must accommodate required 20 x 25 x 1 inch air filter to maintain proper velocity
- Bottom return air
- Return air from both sides
- Bottom and one side return air
- See Blower Performance Tables for additional information

Coil Match-Up

- All furnaces exactly match Lennox cased upflow indoor coils and horizontal indoor coils with same letter designation (A, B, C, D) in model number
- No adaptor required
- Engaging holes furnished on cabinet for alignment
- Lennox uncased coils match furnaces without any overhang but require an optional adaptor base or field fabricated transition to match furnace opening
- See coil bulletin for additional information

Low Leakage Cabinet

- All models have less than 2% air leakage
- Meets ANSI/ASHRAE Standard 193-2010 "Method of Test for Determining the Air Tightness of HVAC Equipment"

Optional Accessories

Horizontal Suspension Kit

- Provides suspension of unit and indoor coil in horizontal applications
- Allows complete service access
- Consists of corner mounted hanging brackets with vibration isolators, return air end support rail and hardware for assembly
- Metal hanging straps must be field provided

Return Air Base

NOTE - On furnaces with side return air and condensate trap on the same side of the cabinet, a field fabricated transition or Return Air Base is required when using an IAQ product higher than 14-3/16 inches installed next to the unit and serviced from the front. IAQ products higher than 20 inches require a field fabricated transition.

NOTE - Must be used for 60C size models with air volumes over 1800 cfm in upflow applications when only one side return is required.

- Cabinet is shipped flat for easy field assembly
- Pre-painted steel to match the furnace
- See Dimension Drawing

High Performance Economizer (Commercial Applications Only)

- Designed for applications requiring outdoor air to be utilized in a commercial HVAC system
- Allows the entry of fresh outdoor air for free cooling, reducing the requirement for mechanical cooling
- Heavy gauge galvanized steel cabinet lined with thick fiberglass insulation
- Mixed air sensor, outdoor air sensor and 24VAC transformer furnished
- Approved for California Title 24 building standards. ASHRAE 90.1-2010 compliant
- See separate Product Specifications bulletin for additional information and available control and sensor options

INDOOR AIR QUALITY PRODUCT OPTIONS

Healthy Climate® PureAir® Air Purification System

- Filtration - The Carbon Clean 16® (MERV 16) media filter captures more than 95% of particles 0.3 microns and larger and more than 90% of particles 0.01 microns and larger
- Highest airflow performance and lowest pressure drop when compared to a leading brand.
- Long life filters up to 1 year



Healthy Climate® Media Air Cleaner

- High performance in a narrow 7 in. cabinet
- Available with MERV 11, 13, or 16 rated filters
- Multi-position heavy gauge steel cabinet will support furnace/coil or air handler and associated duct work
- Tool-less entry
- Tool-less assembly for quick installation



Healthy Climate® Whole Home In Duct Air Purifiers

- Compact Duct Mounted Design
- Effective against odors and VOC's
- Certified Ozone free
- UVC lamp and carbon cells



Healthy Climate® Ultraviolet Germicidal Lights

- Compact duct mounted design
- Single or dual applications
- Certified ozone free
- Effective against odors to help keep the system clean
- Safety Interlocks (Additional UVC Compliance Kit for UL 60335-2-40 is available for A2L applications)
- Low power consumption
- Available for 24V or 110/230V
- Up to 1340 microwatts /cm² output (dual lamp model)



NOTE - Please refer to the individual Product Specifications for these products for full information.

NOTE - Please refer to the individual Product Specifications for these products for full information.

CONTROL OPTIONS

E40 Smart Wi-Fi Thermostat

- 3 Htg.-2 Clg.
- 7-day, universal, programmable, touchscreen thermostat
- Controls dehumidification during cooling mode and humidification during heating mode
- Smooth Setback Recovery and compressor short-cycle protection
- One-Touch Away Mode, Smart Away™ (geo-fencing), equipment maintenance reminders and scheduling
- Smart home automation compatible with Amazon Alexa®, Google Assistant, Control4®, Building36® and Matter
- Lennox® Home App controls temperature, fan operation, set programs/schedules and set Away mode on a smartphone
- Lennox Smart Tech App allows the installer to commission the system and remotely turn the system on and off during setup or service call on a smartphone



M40 Smart Wi-Fi Thermostat

- 3 Htg.-2 Clg.
- 7-day, universal, programmable, touchscreen thermostat
- Smooth Setback Recovery and compressor short-cycle protection
- One-Touch Away Mode, Smart Away™ (geo-fencing), equipment maintenance reminders and scheduling
- Smart home automation compatible with Apple HomeKit™, Amazon Alexa®, Google Assistant and Matter
- Lennox® Home App controls temperature, fan operation, set programs/schedules and set Away mode on a smartphone
- Lennox Smart Tech App allows the installer to commission the system and remotely turn the system on and off during setup or service call on a smartphone



L40 Smart Wi-Fi Thermostat

- 2 Htg.-1 Clg.
- 7-day, universal, programmable, touchscreen thermostat
- Provides temperature control for gas, electric and heat pumps for single-stage heating or cooling systems (including dual-fuel operation)
- One-Touch Away Mode, Smart Away™ (geo-fencing), equipment maintenance reminders and scheduling
- Smooth Setback Recovery and compressor short-cycle protection
- Smart home automation compatible with Amazon Alexa®, Google Assistant, Control4®, Building36® and Matter
- Lennox® Home App controls temperature, fan operation, set programs/schedules and set Away mode on a smartphone
- Lennox Smart Tech App allows the installer to commission the system and remotely turn the system on and off during setup or service call on a smartphone



NOTE - Please refer to the individual Product Specifications for these products for full information.

INDOOR AIR QUALITY PRODUCT OPTIONS - ORDERING

NOTE - Refer to the individual Product Specifications documents for additional accessories and maintenance items.

Description	Dimensions	Furnace Width	Order Number
PureAir® S Air Purification System			
PCO3S-16-16	17-1/2 x 8-3/4 x 26-1/2	A/B/C	Y8904
PCO3S-20-16	21-1/8 x 8-3/4 x 26-1/2	C/D	Y8903
Healthy Climate® Media Air Cleaner			
HCC16-28 (Cabinet)	17-1/2 x 28-1/2 x 7	A/B/C	Y2920
HCC16-28 (Cabinet) 4-pack	17-1/2 x 28-1/2 x 7	---	Y2921
HCF16-16 (Filter) MERV 16	16 x 25 x 5	---	X6672
HCF16-16 (Expandable Filter) MERV 16	16 x 25 x 5	---	X8306
HCF16-13 MERV 13	16 x 25 x 5	---	19L16
HCF16-11 (Filter) MERV 11	16 x 25 x 5	---	X6670
HCF16-11 (Expandable Filter) MERV 11	16 x 25 x 5	---	X8303
HCC20-28 (Cabinet)	21 x 28-1/2 x 7	C/D	X6661
HCC20-28 (Cabinet) 4-pack	21 x 28-1/2 x 7	---	X7751
HCF20-16 (Filter) MERV 16	20 x 25 x 5	---	X6675
HCF20-16 (Expandable Filter) MERV 16	20 x 25 x 5	---	X8307
HCF20-13 MERV 13	20 x 25 x 5	---	19L17
HCF20-11 (Filter) MERV 11	20 x 25 x 5	---	X6673
HCF20-11 (Expandable Filter) MERV 11	20 x 25 x 5	---	X8304
Healthy Climate® Whole Home In Duct Air Purifiers			
HCWHAP1	8 x 7 x 16.5	---	23V99
Healthy Climate® Ultraviolet Germicidal Lights			
UVC-24V (24V) 17-1/2 in.	Ballast 4-3/4 x 2-1/4 x 2	---	X9423
UVC-41W-S (110/230V) 17-1/2 in.	Ballast 11-3/4 x 2-3/4 x 1-5/8	---	X9424
UVC-41W-D (110/230V) 17-1/2 in.	Ballast 11-3/4 x 2-3/4 x 1-5/8	---	X9425
CONTROLS - ORDERING			
E40 Smart Wi-Fi Thermostat	3-3/8 x 5-3/8 x 1	---	30L26
Lennox® Smart Room Sensor	4 x 5-1/2 x 3	---	22V25
Lennox® Smart Air Quality Monitor	3-5/8 x 4-3/8 x 1-3/8	---	21P02
Lennox® Wireless Extender	4 x 5-1/2 x 2-1/2	---	22V26
L40 Smart Wi-Fi Thermostat	2-13/16 x 2-13/16 x 1/4	---	27V51
M40 Smart Wi-Fi Thermostat	3-5/16 x 4-5/16 x 7/8	---	30L27
Thermostat Accessories			
¹ Discharge Air Temperature Sensor (For S40, E40)			88K38
² Remote Outdoor Air Temperature Sensor (For E40/L40) (For dual-fuel and Humiditrol®)			X2658

¹ Optional for service diagnostics (E40).

² Remote Outdoor Air Temperature Sensor is used with conventional (non-Lennox® Communicating) outdoor units (sensor is furnished with Lennox® Communicating outdoor units). Allows the thermostat to display outdoor temperature. Required in dual-fuel and Humiditrol® applications.

99% WINTER DESIGN TEMPERATURES FOR THE CONTIGUOUS UNITED STATES



This map is a necessarily generalized guide to temperatures in the contiguous United States. Temperatures shown for areas such as mountainous regions and large urban centers may not be accurate. The data used to develop this map was taken from the 1993 ASHRAE Fundamentals Handbook (Chapter 24, Table 1: Climate Conditions for the United States).

Reprinted with permission from NFPA 54: National Fuel Gas Code 1999, National Fire Protection Association, Quincy, MA 02269. This reprinted material is not the complete and official position of the National Fire Protection Association on the referenced subject, which is represented only by the standard in its entirety.

INSTALLATION CLEARANCES

UPFLOW POSITION

Vent Type	Type B1	Type C
Sides	1 (25)	¹ 1 (25)
Left Side with furnished Air Intake Pipe Assembly	4-1/2 (114)	4-1/2 (114)
Left Side with Optional Low Profile Air Intake Pipe Kit	2-3/4 (70)	2-3/4 (70)
Rear	1 (25)	1 (25)
Top	1 (25)	1 (25)
Front	¹ 2-1/4 (57)	² 2-1/4 (57)
Front (service/alcove)	24 (610)	24 (610)
Floor	Combustible	Combustible
Flue	1 (25)	6 (152)

NOTE – Air for combustion must conform to the methods outlined in the National Fuel Gas Code (NFPA 54/ANSI-Z223.1).

NOTE – In the U.S. flue sizing must conform to the methods outlined in the current National Fuel Gas Code (NFPA 54/ANSI-Z223.1) or applicable provisions of local building codes.

¹ Left side requires 3 in. if single wall vent is used on 14-1/2 in. cabinets, 2 in. on 17-1/2 in. cabinets.

² 4-1/2 in. if single wall vent pipe is used.

HORIZONTAL POSITION

Vent Type	Type B1	Type C
End	¹ 2	¹ 2
Rear	1 (25)	1 (25)
Top	¹ 1 (25)	¹ 1 (25)
Top or Bottom with furnished Air Intake Pipe Assembly	4-1/2 (114)	4-1/2 (114)
Top or Bottom with Optional Low Profile Air Intake Pipe Kit	2-3/4 (70)	2-3/4 (70)
Front	2-1/4 (57)	2-1/4 (57)
Front (service)	24 (610)	24 (610)
Floor	Combustible	Combustible
Flue	1 (25)	6 (152)

NOTE – Air for combustion must conform to the methods outlined in the National Fuel Gas Code (NFPA 54/ANSI-Z223.1).

NOTE – In the U.S. flue sizing must conform to the methods outlined in the current National Fuel Gas Code (NFPA 54/ANSI-Z223.1) or applicable provisions of local building codes.

¹ Line contact installation permissible between jacket top or sides and building joists.

HIGH ALTITUDE OPERATION

Units may be installed at altitudes up to 7500 ft. above sea level without any modification.

SPECIFICATIONS

Gas Heating Performance	Model	EL180UH 040NE36AK	EL180UH 060NE36AK	EL180UH 080NE48BK	EL180UH 100NE60CK
	¹ AFUE	80%	80%	80%	80%
	Input - Btuh	40,000	60,000	80,000	100,000
	Output - Btuh	33,000	48,000	64,000	80,000
	Temperature rise range - °F	20 - 50	30 - 60	30 - 60	35 - 65
	Gas Manifold Pressure (in. w.g.) Nat. Gas Only	0.05	0.05	0.05	0.05
	High Static - in. w.g.	0.50	0.50	0.50	0.50
Connections	Flue connection - in. round	4	4	4	4
	² Air Intake - in. round	2	2	2	2
	Gas pipe size IPS	1/2	1/2	1/2	1/2
Indoor Blower	Wheel diameter x width - in.	10 x 8	10 x 8	10 x 10	11-1/2 x 10
	Motor Type	DC Brushless	DC Brushless	DC Brushless	DC Brushless
	Motor output - hp	1/2	1/2	3/4	1
	Tons of add-on cooling	1.5 - 3	1.5 - 3	2.5 - 4	3 - 5
	Air Volume Range - cfm	350 - 1380	395 - 1415	750 - 1785	920 - 2315
Electrical Data	Voltage	120 volts - 60 hertz - 1 phase			
	Blower motor full load amps	6.4	6.4	9.3	12.3
	Maximum overcurrent protection	15	15	15	15
Shipping Data	lbs. - 1 package	119	119	140	157

NOTE - Filters and provisions for mounting are not furnished and must be field provided.

¹ Annual Fuel Utilization Efficiency based on DOE test procedures and according to FTC labeling regulations. Isolated combustion system rating for non-weatherized furnaces.

² Requires furnished Air Intake Pipe Assembly.

OPTIONAL ACCESSORIES - ORDER SEPARATELY

		"A" Width Models	"B" Width Models	"C" Width Models
CABINET ACCESSORIES				
Horizontal Suspension Kit - Horizontal only		51W10	51W10	51W10
Return Air Base - Upflow only		N/A	50W98	50W99
High Performance Economizer (Commercial Only)		10U53	10U53	10U53
CONTROLS				
Blower Relay Kit (for two-stage outdoor units)		85W66	85W66	85W66
Transformer (75VA)		27J32	27J32	27J32
FILTERS				
¹ Air Filter and Rack Kit	Horizontal (end)	87L95	87L96	87L97
	Size of filter - in.	14 x 25 x 1	18 x 25 x 1	20 x 25 x 1
	Side Return Single	N/A	44J22	44J22
	Ten Pack	N/A	66K63	66K63
	Size of filter - in.	N/A	16 x 25 x 1	16 x 25 x 1
INTAKE / VENTING				
Combustion Air Intake Muffler Kit		29K98	29K98	29K98
Low Profile Air Intake Pipe Kit - 2 in.		25B23	25B23	25B23
Vent Adaptor - 6 in. conn. size upflow applications only		18M79	18M79	18M79

¹ Cleanable polyurethane, frame-type filter.

DIMENSIONS

UNIT - UPFLOW POSITION

¹ NOTE - 60C size units that require air volumes over 1800 cfm must have one of the following:

1. Single side return air and Optional Return Air Base with transition that must accommodate required 20 x 25 x 1 inch (508 x 635 x 25 mm) air filter to maintain proper velocity.
2. Bottom return air.
3. Return air from both sides.
4. Bottom and one side return air.

See Blower Performance Tables for additional information.

² Flue outlet is only on top of furnace **must** be vented vertically.

³ Optional External Side Return Air Filter Kit is not for use with the optional Return Air Base.

⁴ Optional External Side Return Air Filter Kit is not available for "A" width cabinets.

⁵ 2-3/4 in. (70 mm) for optional Low Profile Air Intake Pipe Kit.

⁶ NOTE - Gas entry is only available on the left side of the cabinet for "A" width cabinet models.

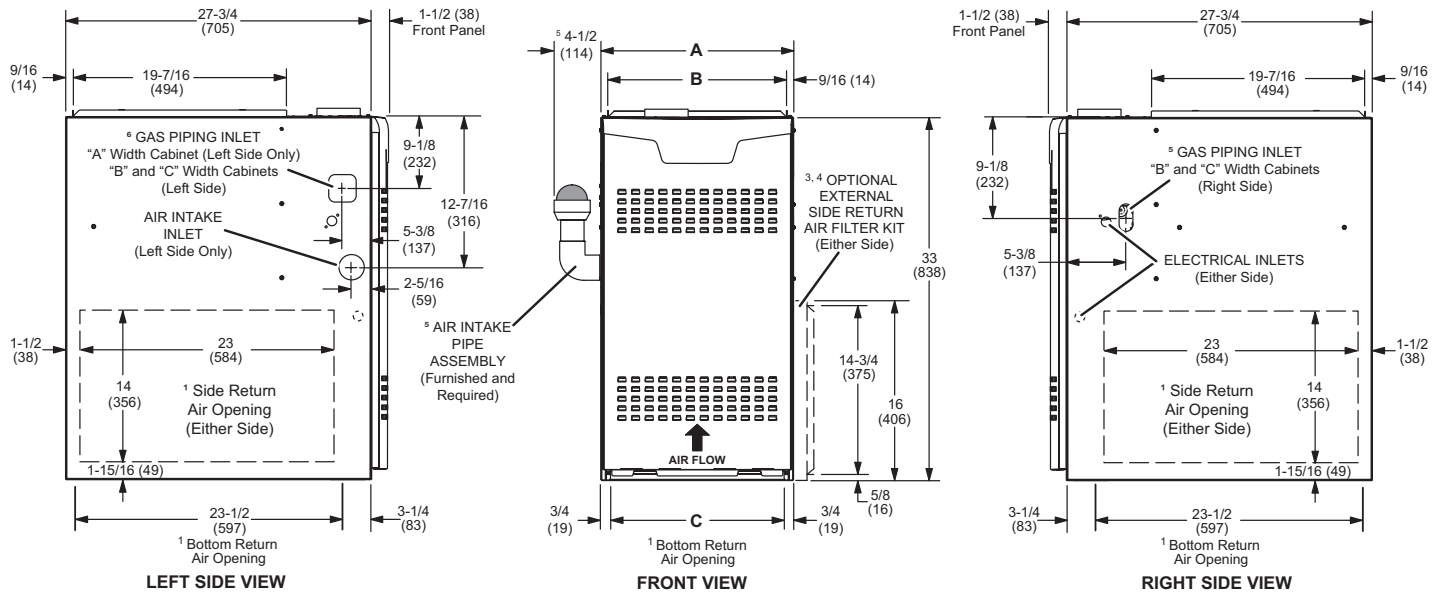
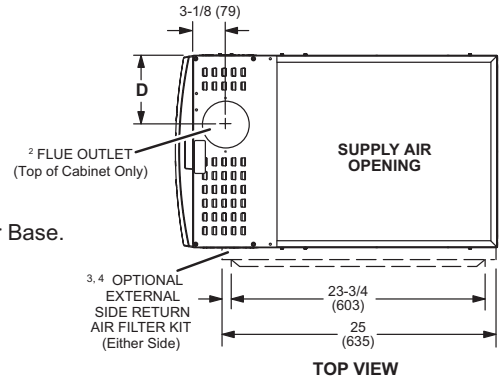

Model No.	A		B		C		D	
	in.	mm	in.	mm	in.	mm	in.	mm
EL180UH040NE36AK	14-1/2	368	13-3/8	340	13	330	4-3/4	121
EL180UH060NE36AK								
EL180UH080NE48BK	17-1/2	446	16-3/8	416	16	406	6-1/4	159
EL180UH100NE60CK	21	533	19-7/8	504	19-1/2	495	8	203

DIMENSIONS

UNIT - HORIZONTAL POSITION

LEFT-HAND AIR DISCHARGE

NOTE - Air Intake Termination is only available on the bottom of the cabinet with left-hand air discharge.
 NOTE - Air Intake Pipe must be FIRMLY secured in this position to prevent disconnection!

¹ NOTE - Gas entry is only available on the bottom of the cabinet for "A" width cabinet models with left-hand air discharge.

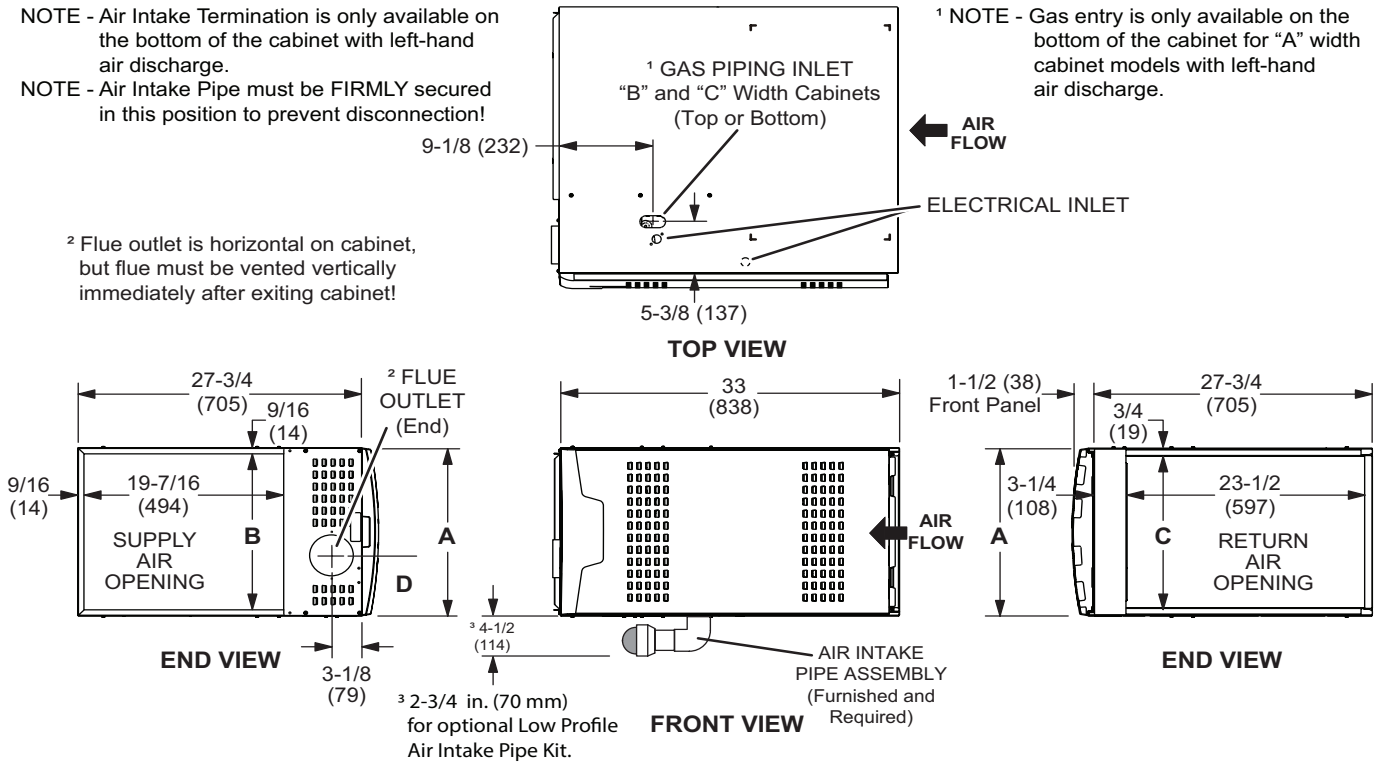

RIGHT-HAND AIR DISCHARGE

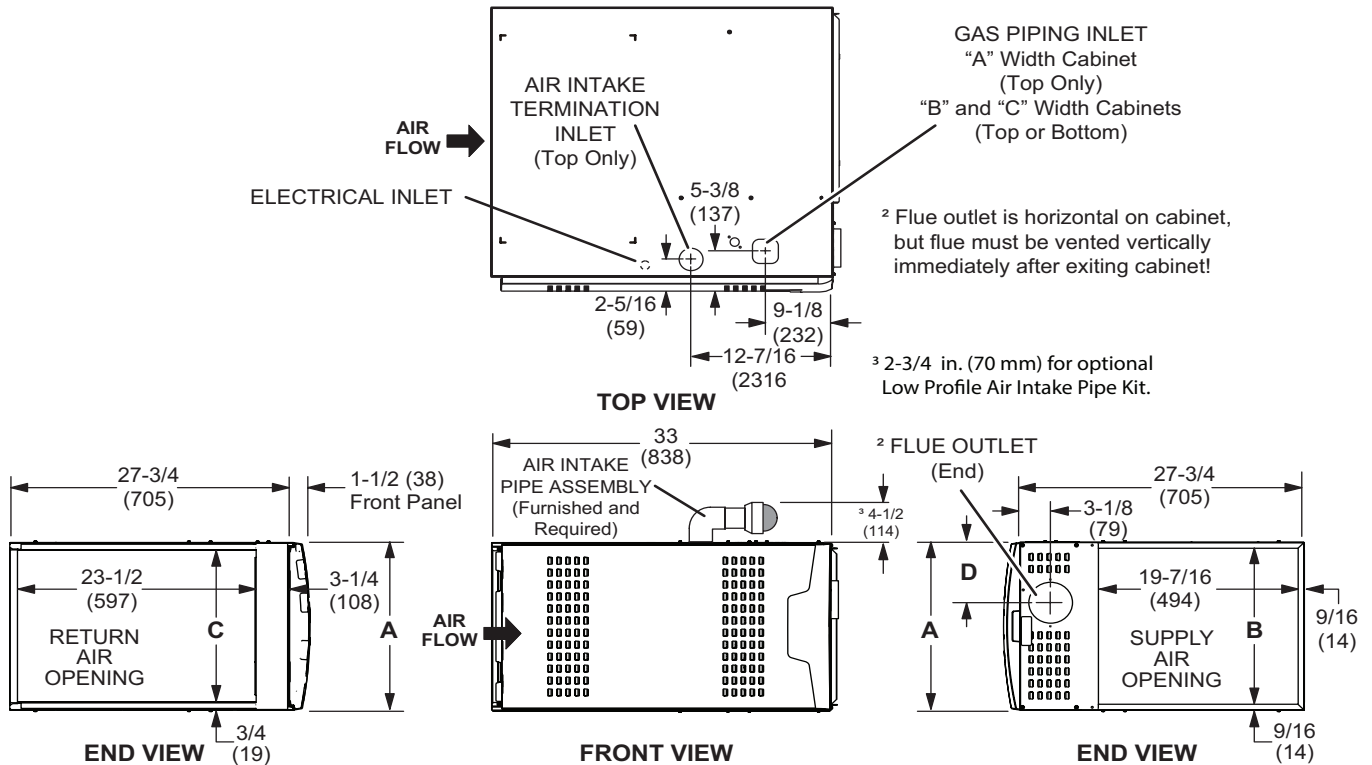

Model No.	A		B		C		D	
	in.	mm	in.	mm	in.	mm	in.	mm
EL180UH040NE36AK EL180UH060NE36AK	14-1/2	368	13-3/8	340	13	330	4-3/4	121
EL180UH080NE48BK	17-1/2	446	16-3/8	416	16	406	6-1/4	159
EL180UH100NE60CK	21	533	19-7/8	504	19-1/2	495	8	203

HORIZONTAL (END) FILTER KIT

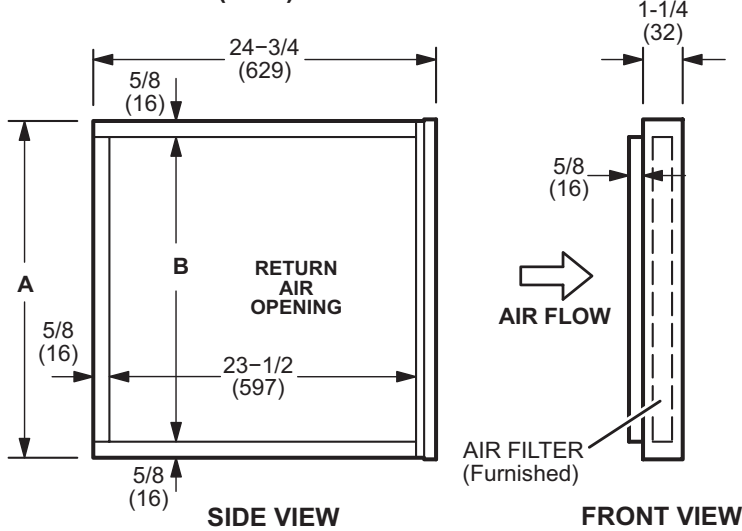

Furnace Cabinet Width	Catalog Number	A		B	
		in.	mm	in.	mm
A	87L95	14	356	12-3/4	324
B	87L96	18	457	16-3/4	425
C	87L97	21	533	18-3/4	476

**COMBUSTION AIR INTAKE MUFFLER KIT
29K98 - 2-inch**

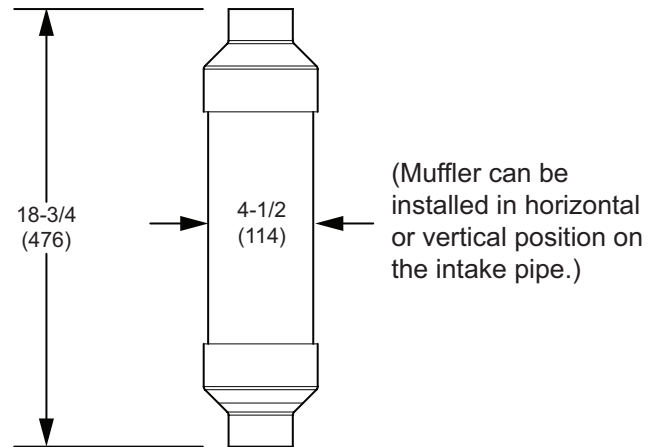

**Optional Return Air Base
(Upflow Applications Only - For use with B and C width cabinets)**

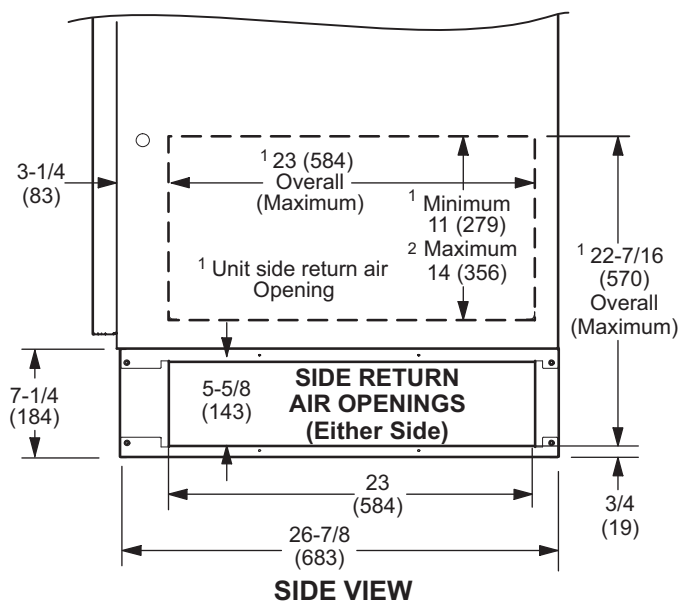
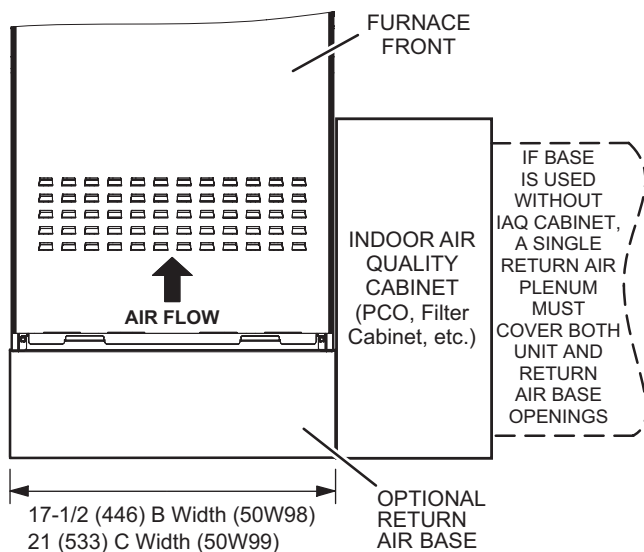

NOTE- Optional Side Return Air Filter Kits are not for use with Optional Return Air Base.

- ¹ Both the unit return air opening and the base return air opening must be covered by a single plenum or IAQ cabinet. Minimum unit side return air opening dimensions for units requiring 1800 cfm or more of air (W x H): 23 x 11 in. (584 x 279 mm). The opening can be cut as needed to accommodate plenum or IAQ cabinet while maintaining dimensions shown. Side return air openings must be cut in the field. There are cutting guides stenciled on the cabinet for the side return air opening. The size of the opening must not extend beyond the markings on the furnace cabinet.
- ² To minimize pressure drop, the largest opening height possible, up to 14 in. (356 mm), is preferred.

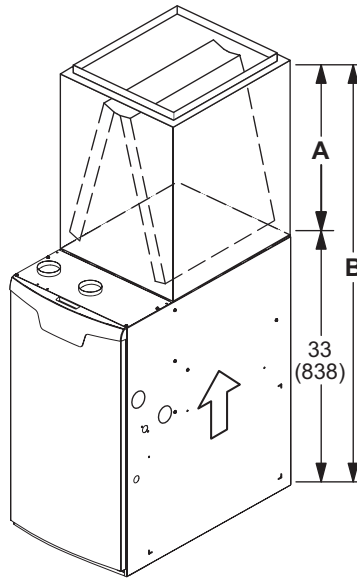

UPFLOW POSITION - CASED

Model	A		B	
	in.	mm	in.	mm
CK40CT				
CK40CT-18/24A CK40CT-18/24B	16-1/2	419	49-1/2	1257
CK40CT-24A CK40CT-24B	18-1/2	470	51-1/2	1308
CK40CT-30A CK40CT-30B	22-1/2	572	55-1/2	1410
CK40CT-30/36A CK40CT-30/36B CK40CT-30/36C	24-1/2	622	57-1/2	1461
CK40CT-36A CK40CT-36B CK40CT-36C	24-1/2	622	57-1/2	1461
CK40CT-48B CK40CT-48C	27-1/2	699	60-1/2	1537
CK40CT-49C	29-1/2	749	62-1/2	1588
CK40CT-50/60C	27-1/2	699	60-1/2	1537
CK40CT-60C	31-1/2	800	64-1/2	1638

UPFLOW POSITION - UNCASSED

Model	A		B	
	in.	mm	in.	mm
CK40UT				
CK40UT-18/24A CK40UT-18/24B	14-1/8	359	47-1/8	1197
CK40UT-24A CK40UT-24B	16-3/8	416	49-3/8	1254
CK40UT-30A CK40UT-30B	20-3/4	527	53-3/4	1365
CK40UT-30/36A CK40UT-30/36B CK40UT-30/36C CK40UT-36C	22-1/4	565	55-1/4	1403
CK40UT-36A CK40UT-36B	22-3/8	568	55-3/8	1407
CK40UT-48B CK40UT-48C	26-1/4	667	59-1/4	1505
CK40UT-49C	28-1/2	724	61-1/2	1562
CK40UT-50/60C	25-7/8	657	58-7/8	1495
CK40UT-60C	30-5/8	778	63-5/8	1616

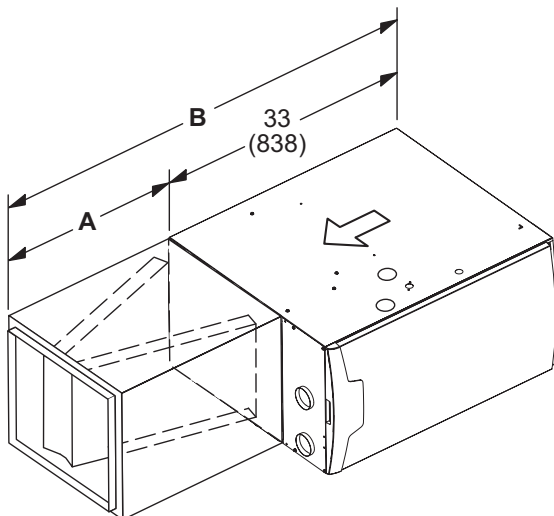

HORIZONTAL POSITION

Model	A		B	
	in.	mm	in.	mm
CK40HT				
CK40HT-18A CK40HT-24A CK40HT-24B CK40HT-30B CK40HT-36A CK40HT-36B CK40HT-36C CK40HT-42C CK40HT-48C	26-1/2	673	59-1/2	1511
CK40CT-30A CK40CT-42B CK40CT-48B CK40CT-51/61C	31-1/2	880	64-1/2	1638

BLOWER DATA

EL180UH040NE36AK PERFORMANCE (Less Filter)

External Static Pressure in. w.g.	Air Volume / Watts at Various Blower Speeds									
	High (Black)		Medium-High (Brown)		Medium (Blue)		Medium-Low (Yellow)		Low (Red)	
	cfm	Watts	cfm	Watts	cfm	Watts	cfm	Watts	cfm	Watts
0.10	1389	251	1146	156	1007	111	963	98	945	94
0.20	1355	267	1098	171	935	115	826	89	789	79
0.30	1315	280	1068	184	881	126	768	97	646	75
0.40	1278	287	1022	194	837	133	709	108	593	84
0.50	1247	303	978	203	782	144	646	116	529	92
0.60	1199	317	948	216	719	151	602	126	471	102
0.70	1176	328	899	228	679	163	537	131	422	106
0.80	1128	344	860	235	627	172	500	141	382	115
0.90	1075	347	821	246	577	179	454	146	320	118
1.00	966	322	771	256	546	188	416	154	292	121

EL180UH060NE36AK PERFORMANCE (Less Filter)

External Static Pressure in. w.g.	Air Volume / Watts at Various Blower Speeds									
	High (Black)		Medium-High (Brown)		Medium (Blue)		Medium-Low (Yellow)		Low (Red)	
	cfm	Watts	cfm	Watts	cfm	Watts	cfm	Watts	cfm	Watts
0.10	1389	251	1146	156	1007	111	963	98	945	94
0.20	1355	267	1098	171	935	115	826	89	789	79
0.30	1315	280	1068	184	881	126	768	97	646	75
0.40	1278	287	1022	194	837	133	709	108	593	84
0.50	1247	303	978	203	782	144	646	116	529	92
0.60	1199	317	948	216	719	151	602	126	471	102
0.70	1176	328	899	228	679	163	537	131	422	106
0.80	1128	344	860	235	627	172	500	141	382	115
0.90	1075	347	821	246	577	179	454	146	320	118
1.00	966	322	771	256	546	188	416	154	292	121

EL180UH080NE48B PERFORMANCE (Less Filter)

External Static Pressure in. w.g.	Air Volume / Watts at Various Blower Speeds									
	High (Black)		Medium-High (Brown)		Medium (Blue)		Medium-Low (Yellow)		Low (Red)	
	cfm	Watts	cfm	Watts	cfm	Watts	cfm	Watts	cfm	Watts
0.10	1828	419	1640	297	1503	238	1440	209	1240	147
0.20	1775	438	1571	318	1446	255	1385	229	1187	159
0.30	1727	457	1515	335	1393	275	1323	244	1110	173
0.40	1676	473	1477	349	1340	292	1263	259	1058	190
0.50	1632	490	1422	376	1290	309	1200	276	991	201
0.60	1575	509	1370	391	1227	326	1154	290	922	218
0.70	1502	507	1309	407	1171	343	1092	305	869	232
0.80	1335	460	1267	422	1114	357	1043	320	804	243
0.90	1115	395	1091	381	1047	367	984	334	735	255
1.00	829	310	845	322	846	318	858	321	669	266

BLOWER DATA

EL180UH100NE60CK (Less Filter)

External Static Pressure in. w.g.	Air Volume / Watts at Different Blower Speeds																			
	Bottom Return Air, Side Return Air with Return Air from Both Sides or Return Air from Bottom and One Side.										Single Side Return Air - Air volumes in bold (over 1800 cfm) require Optional Return Air Base and field fabricated transition to accommodate 20 x 25 x 1 in. air filter in order to maintain proper air velocity.									
	High (Black)		Medium-High (Brown)		Medium (Blue)		Medium-Low (Yellow)		Low (Red)		High (Black)		Medium-High (Brown)		Medium (Blue)		Medium-Low (Yellow)		Low (Red)	
	cfm	Watts	cfm	Watts	cfm	Watts	cfm	Watts	cfm	Watts	cfm	Watts	cfm	Watts	cfm	Watts	cfm	Watts	cfm	Watts
0.10	2216	637	1961	438	1707	305	1576	245	1457	193	2245	633	1980	427	1763	299	1592	240	1486	194
0.20	2165	663	1921	460	1667	324	1515	255	1323	190	2199	653	1931	454	1685	323	1533	253	1343	189
0.30	2129	684	1853	486	1624	344	1460	275	1262	208	2147	678	1876	474	1640	343	1470	273	1276	205
0.40	2060	710	1818	508	1559	365	1401	294	1193	222	2110	702	1815	491	1574	358	1424	292	1198	219
0.50	2030	726	1775	526	1515	380	1346	317	1134	238	2064	725	1777	516	1525	375	1360	312	1134	236
0.60	1985	749	1707	547	1453	401	1312	332	1080	252	2025	744	1726	533	1476	398	1311	330	1083	253
0.70	1931	769	1662	567	1405	419	1238	346	1012	269	1973	765	1673	558	1417	420	1243	344	1025	268
0.80	1882	789	1617	586	1364	438	1190	364	946	278	1925	788	1636	577	1372	436	1193	361	955	277
0.90	1832	807	1565	606	1317	457	1135	381	893	294	1883	806	1575	597	1312	457	1148	378	908	148
1.00	1727	772	1533	623	1244	468	1059	397	823	304	1785	789	1531	616	1263	469	1089	390	838	301

REVISIONS

Sections	Description of Change
Control Options	Updated to reflect latest product offering.
Dimensions	Updated Furnace/Coil Combined Dimensions to add latest product offering.



Visit us at www.Lennox.com

For the latest technical information, www.LennoxPros.com

Contact us at 1-800-9-LENNOX

NOTE - Due to Lennox' ongoing commitment to quality, Specifications, Ratings and Dimensions subject to change without notice and without incurring liability. Improper installation, adjustment, alteration, service or maintenance can cause property damage or personal injury. Installation and service must be performed by a qualified installer and servicing agency.

©2026 Lennox Industries, Inc.