

VRF (Variable Refrigerant Flow) Installation manual

VPD****6M-5P

- Thank you for purchasing this Lennox Product.
- Before operating this unit, please read this manual carefully and retain it for future reference.

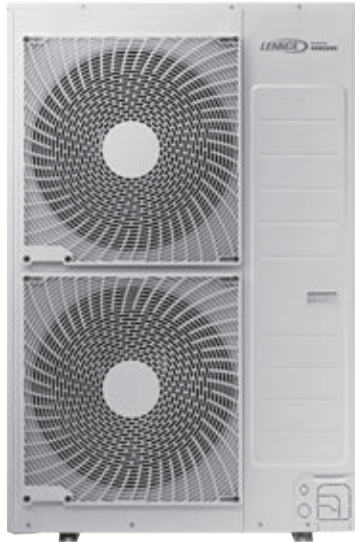

Contents

Safety precautions	3
R-32 General Guidelines for Compliance	13
Preparing for installation	21
Selecting installation location	23
Space requirement for installation	25
Installation and base ground work for an outdoor unit	28
Refrigerant pipe installation	30
Wiring work	50
Grounding work	55
Charging refrigerant	56
Basic segment display	58
Setting outdoor unit option switch and key function	58
Inspection and check operation	66
Checklist after finishing installation	68
Automatic refrigerant amount detection function (Checking th amount of refrigerant)	70
Trial operation	71

Safety precautions

California Proposition 65 Warning (US)



WARNING

Cancer and Reproductive Harm - www.P65Warnings.ca.gov.



WARNING





- Read and follow all safety information and instructions before installation, use, or maintenance of this appliance. Incorrect installation, use, or maintenance of this appliance can result in death, serious injury, or property damage. Keep these instructions with this appliance. This manual is subject to change. For the latest version, visit www.lennoxpros.com for dealer/contractor.
-

IMPORTANT – This product has been designed and manufactured to meet ENERGY STAR criteria for energy efficiency when matched with appropriate coil components.







However, proper refrigerant charge and proper air flow are critical to achieve rated capacity and efficiency. Installation of this product should follow the manufacturer's refrigerant charging and air flow instructions. Failure to confirm proper charge and airflow may reduce energy efficiency and shorten equipment life.

Notices and notes

To make you aware of safety messages and highlighted information, we use the following notices and notes throughout this manual:

 WARNING	Hazards or unsafe practices may result in severe personal injury or death.
 CAUTION	Hazards or unsafe practices may result in minor personal injury or property damage.
 IMPORTANT	Information of special interest
 NOTE	Supplementary information that may be useful

Safety precautions

Symbol	Meaning
	Flammable gas
	Flammable materials
	Refrigerant safety group
	Read installation manual
	Refer to installation manual
	Read service manual



- The installation and testing of this appliance must be performed by a qualified technician.
- The instructions in this manual are not intended as a substitute for proper training or adequate experience in the safe installation of the appliance.
- Always install the air conditioner in compliance with current local, state, and federal safety standards.

General information

- ▶ Carefully read the content of this manual before installing the air conditioner and store the manual in a safe place to be able to use it as a reference after installation.
- ▶ For maximum safety, installers should always carefully read the following warnings.
- ▶ Store the operation and installation manual in a safe location and remember to hand it over to the new owner if the air conditioner is sold or transferred.
- ▶ Using other types of units with different control systems may damage the units and invalidate the warranty. The manufacturer shall not be responsible for damages arising from the use of non-compliant units.
- ▶ The manufacturer shall not be responsible for damage originating from unauthorized changes or the improper connection of electricity and requirements outlined in the "Operating limits" table, included in the manual, shall immediately invalidate the warranty.

-
- ▶ The air conditioner should be used only for the applications for which it has been designed: the indoor unit is not suitable to be installed in areas used for laundry.
 - ▶ Do not use the units if damaged. If problems occur, switch the unit off and disconnect it from the power supply.
 - ▶ To prevent electric shocks, fires or injuries, always stop the unit, disable the protection switch and contact LENNOX's technical support if the unit produces smoke, if the power cable is hot or damaged or if the unit is very noisy.
 - ▶ Always remember to inspect the unit, electric connections, refrigerant tubes and protections regularly. These operations should be performed by qualified personnel only.
 - ▶ The unit contains moving parts, which should always be kept out of the reach of children.
 - ▶ Do not attempt to repair, move, alter or reinstall the unit. If performed by unauthorized personnel, these operations may cause electric shocks or fires.
 - ▶ Do not place containers with liquids or other objects on the unit.
 - ▶ All the materials used for the manufacture and packaging of the air conditioner are recyclable.
 - ▶ The air conditioner contains a refrigerant that must be disposed of as special waste. At the end of its life cycle, the air conditioner must be disposed of in authorized centers or returned to the retailer so that it can be disposed of correctly and safely.
 - ▶ Wear protective equipment (such as safety gloves, goggles, and headgear) during installation and maintenance work. Installation/ repair technicians may be injured if improper protective equipment is worn.
 - ▶ Do not use means to accelerate the defrost operation or to clean, other than those recommended by LENNOX.
 - ▶ Do not pierce or burn.
 - ▶ Be aware that refrigerants may not contain an odor.
 - ▶ This appliance is not intended for use by persons (including children) with reduced physical, sensory, or mental capabilities, or lack of experience and knowledge unless they have been given supervision or instruction concerning the use of the appliance by a person responsible for their safety. Children should be supervised to ensure that they do not play with the appliance.

Installing the unit

IMPORTANT: When installing the unit, always remember to connect first the refrigerant tubes, and then the electrical lines.

- ▶ Connecting one indoor unit to this product is prohibited.
- ▶ Upon receipt, inspect the product to verify that it has not been damaged during transport. If the product appears damaged, DO NOT INSTALL it, and immediately report the damage to the carrier or retailer (if the installer or the authorized technician has collected the material from the retailer.)
- ▶ After completing the installation, always carry out a functional test and provide instructions on how to operate the air conditioner to the user.
- ▶ Do not use the air conditioner in environments with hazardous substances or close to equipment that releases free flames to avoid the occurrence of fires, explosions or injuries.
- ▶ Our units should be installed in compliance with the spaces shown in the installation manual, to ensure accessibility from both sides and allow repairs or maintenance operations to be carried out. The unit's components should be accessible and easy to disassemble without endangering people and objects.

Safety precautions

- ▶ For this reason, when provisions of the installation manual are not complied with, the cost required to access and repair the units (in SAFETY CONDITIONS, as set out in prevailing regulations) with harnesses, ladders, scaffolding or any other elevation system will NOT be considered part of the warranty and will be charged to the end customer.
- ▶ The outdoor unit shall be installed in an open space that is always ventilated.
- ▶ Please adhere to the local gas regulations.
- ▶ To handle, purge, and dispose of the refrigerant, or to break into the refrigerant circuit, the technician should have a certificate from an industry-accredited authority.
- ▶ While in installation or relocation of the product, do not mix the refrigerant with other gases including air or unspecified refrigerant. Failure to do so may cause pressure increase to result in rupture or injury.
- ▶ Do not cut or burn the refrigerant container or piping.
- ▶ Use clean parts such as manifold gauge, vacuum pump, and charging hose for the refrigerant.
- ▶ Installation must be carried out by qualified personnel handling the refrigerant. Additionally, reference local and national regulations and laws.
- ▶ Be careful not to let foreign substances (lubricating oil, refrigerant, water, etc.) enter the pipes.
- ▶ When mechanical ventilation is required, ventilation openings shall be kept clear of obstruction.
- ▶ For disposal of the product, follow the local laws and regulations.
- ▶ Do not work in a confined place.
- ▶ The work area shall be secured to only allow access by the technician(s).
- ▶ The refrigerant pipes shall be installed in a position where there are no substances that may result in corrosion.
- ▶ The following checks shall be performed for installation:
 - The charge amount depends on the room size.
 - The ventilation devices and outlets are operating normally and are not obstructed.
 - Markings and signs on the equipment shall be visible and legible.
- ▶ Upon leakage of the refrigerant, ventilate the room. When the leaked refrigerant is exposed to flame, it may cause the generation of toxic gases.
- ▶ Make sure that the work area is safe from flammable substances.
- ▶ To purge air in the refrigerant pipes, be sure to use a vacuum pump.
- ▶ Note that the refrigerant has no odor.
- ▶ The units are not explosion proof so they must be installed with no risk of explosion.
- ▶ This product contains fluorinated gases that contribute to the global greenhouse effect. Accordingly, do not vent gases into the atmosphere.
- ▶ For installation with handling the refrigerant(R-32), use dedicated tools and piping materials. The working pressure of R-32 is higher than R410A, so failure to use the dedicated tools and piping materials may cause rupture or injury. Furthermore, it may cause serious accidents such as water leakage, electric shock or fire.
- ▶ Servicing shall be performed as recommended by the manufacturer. In case other skilled persons are joined for servicing; it shall be carried out under the supervision of the person who is competent in handling flammable refrigerants.
- ▶ For servicing the units containing flammable refrigerants, safety checks are required to minimize the risk of ignition.
- ▶ Servicing shall be performed following the controlled procedure to minimize the risk of flammable refrigerants or gases.

-
- ▶ Do not install where there is a risk of combustible gas leakage.
 - ▶ Do not place near heat sources
 - ▶ Be cautious not to generate a spark as follows:
 - Do not remove fuses with power on.
 - ▶ If the indoor unit is not R-32 compatible, an error signal appears and the unit will not operate.
 - ▶ After installation, check for leakage. Toxic gas may be generated if it comes into contact with an ignition source such as a fan heater or stove.
 - ▶ Never directly touch any accidental leaking refrigerant. It could result in severe wounds caused by frostbite.

Preparation of fire extinguisher

- ▶ If flammable work is to be done, appropriate fire extinguishing equipment should be available.
- ▶ Have a dry CO₂ fire extinguisher adjacent to the charging area and workspace.

Ignition source safety

- ▶ Make sure to store the units in a place without continuously operating ignition sources (for example, open flames, an operating gas appliance or an operating electric heater).
- ▶ The service technician shall not use any ignition sources with the risk of fire or explosion.
- ▶ Potential ignition sources shall be kept away from the work area where the flammable refrigerant can be released into the surrounding area.
- ▶ The work area should be checked to ensure that there are no flammable hazards or ignition risks. The "No Smoking" sign shall be attached.
- ▶ Under no circumstances shall potential sources of ignition be used while detecting refrigerant leaks.
- ▶ Make sure that the seals or sealing materials have not degraded.
- ▶ Safe parts are the ones with which the worker can work in a flammable atmosphere. Other parts may result in ignition due to leakage.
- ▶ Replace components only with parts specified by LENNOX. Other parts may result in the ignition of refrigerant in the atmosphere from a leak.

Area ventilation

- ▶ Make sure that the work area is well ventilated before performing hot work.
- ▶ Ventilation shall be made even during work.
- ▶ The ventilation should safely disperse any released gases and preferably expel them into the atmosphere.

Leakage detection methods

- ▶ The leakage detector shall be calibrated in a refrigerant-free area.
- ▶ Make sure that the detector is not a potential source of ignition.
- ▶ The leakage detector shall be set to the LFL (lower flammability limit).
- ▶ The use of detergents containing chlorine shall be avoided for cleaning because the chlorine may react with the refrigerant and corrode the piping.

Safety precautions

- ▶ If leakage is suspected, naked flames shall be removed.
- ▶ If a leakage is found while brazing, the entire refrigerant charge shall be recovered from the product or isolated (e.g. using shut-off valves). It shall not be directly released into the environment. Oxygen free nitrogen (OFN) shall be used for purging the system before and during the brazing process.
- ▶ The work area shall be checked with an appropriate refrigerant detector before and during work.
- ▶ Ensure that the leakage detector is appropriate for use with flammable refrigerants.

Labeling

- ▶ The parts shall be labeled to ensure that they have been decommissioned and emptied of refrigerant.
- ▶ The labels shall note the date of application.
- ▶ Make sure that the labels are affixed on the system to notify it contains flammable refrigerant.

Recovery

- ▶ When removing refrigerant from the system for servicing or decommissioning, it is recommended to remove the entire refrigerant charge.
- ▶ When transferring refrigerant into cylinders, make sure that only refrigerant recovery cylinders are used.
- ▶ All cylinders used for the recovered refrigerant shall be labeled.
- ▶ Cylinders shall be equipped with pressure relief valves and shut-off valves in a proper order.
- ▶ Empty recovery cylinders shall be evacuated and cooled before recovery.
- ▶ The recovery system shall operate normally according to the specified instructions and shall be suitable for refrigerant recovery.
- ▶ In addition, the calibration scales shall operate normally.
- ▶ Hoses shall be equipped with leak-free disconnect couplings.
- ▶ Before starting the recovery, check for the status of the recovery system and sealing state. Consult with the manufacturer if suspected.
- ▶ The recovered refrigerant shall be returned to the supplier in the correct recovery cylinders with the Waste Transfer Note attached.
- ▶ Do not mix refrigerants in the recovery units or cylinders.
- ▶ If compressors or compressor oils are to be removed, make sure that they have been evacuated to an acceptable level to ensure that flammable refrigerant does not remain in the lubricant.
- ▶ The evacuation process shall be performed before sending the compressor to the suppliers.
- ▶ Only the electrical heating of the compressor body is allowed to accelerate the process.
- ▶ Oil shall be drained safely from the system.
- ▶ For installation with handling the refrigerant (R-32), use dedicated tools and piping materials. Because the pressure of the refrigerant, R-32, is approximately 1.6 times higher than that of R-22, failure to use the dedicated tools and piping materials may cause rupture or injury. Furthermore, it may cause serious accidents such as water leakage, electric shock, or fire.
- ▶ Never install motor-driven equipment to prevent ignition.

Power supply line, fuse or circuit breaker



WARNING

- Always make sure that the power supply is compliant with current safety standards. Always install the air conditioner in compliance with current local safety standards.
- Always verify that a suitable grounding connection is available.
- Verify that the voltage and frequency of the power supply comply with the specifications and that the installed power is sufficient to ensure the operation of any other domestic appliance connected to the same electric lines.
- Always verify that the cut-off and protection switches are suitably dimensioned.
- Verify that the air conditioner is connected to the power supply following the instructions provided in the wiring diagram included in the manual.
- Always verify that electric connections (cable entry, section of leads, protections...) are compliant with the electric specifications and with the instructions provided in the wiring scheme. Always verify that all connections comply with the standards applicable to the installation of air conditioners.
- Devices disconnected from the power supply should be completely disconnected in the condition of overvoltage category.
- Be sure not to perform power cable modification, extension wiring, and multiple wire connections.
 - It may cause electric shock or fire due to poor connection, poor insulation, or current limit override.

Precautions for using R-32 refrigerant

General

- ▶ This product is pre-charged with mildly flammable gas classified as A2L by ASHRAE. The following precautions and instruction manuals must be followed during installation, operation, servicing and decommissioning of the product.
- ▶ The appliance shall be stored in a room without continuously operating ignition sources, like open flames or a gas appliance or an electric heater.
- ▶ All national and local regulations shall be observed at all times.
- ▶ All pipe-work including piping material, pipe routing and installation shall include protection from physical damage in operation and service, and be in compliance with national and local codes and standards, such as ASHRAE 15, ASHRAE 15.2, IAPMO Uniform Mechanical Code, ICC International Mechanical Code, or CSA B52. All field joints shall be accessible for inspection prior to being covered or enclosed.
- ▶ All field piping and joints shall be pressure tested with an inert gas according to prevalent industry standards prior to refrigerant charging and system commissioning.
- ▶ Where additional field charging is required. The installer shall write with a permanent marker the field charge added on the ODU label provided, such that the Total Charge = Factory 'Pre-charge' + field charge.
- ▶ For ducted systems, any auxiliary systems that are potential ignition sources shall not be installed in the duct work. Examples of ignition sources are hot surfaces with temperatures exceeding 1292°F (700°C) and electric switching devices.
- ▶ Any auxiliary device installed must be approved by LENNOX and must be suitable for operating with the refrigerant marked on the label.

Safety precautions

- ▶ Where mechanical ventilation is used, the lower edge of the air extraction opening shall not be more than 3.94 inch (100 mm) above the floor. The exhaust location outside the building must be at least 9.84 ft (3 m) away from the building opening and mechanical air intake openings.
- ▶ To handle, purge, and dispose of the refrigerant, or break into the refrigerant circuit, the worker should have a certificate from an industry accredited authority.
- ▶ Non-ducted systems may be installed in areas such as false ceilings not being used as return air plenum if the conditioned air does not mix with the air in the false ceilings.
- ▶ For ducted appliances false ceiling or drop ceilings may be used as return air plenum if a refrigerant leak detection system is provided in the system and any external connections are also provided with a sensor immediately below the return air plenum duct joint.
- ▶ Installation, servicing and any type of maintenance or repair must be performed by certified personnel that are competent to carry out such activity in accordance with national and local regulations.

General Information on Servicing

- ▶ Do not work in a confined space. Ensure adequate ventilation is provided at the workspace during the entirety of the duration of the work to safely disperse any released refrigerant.
- ▶ All maintenance staff and others working in the local area shall be instructed on the nature of the work being performed and instructed to follow all instructions provided by LENNOX, national and local authorities.
- ▶ The area shall be checked with an approved refrigerant detector before and during any work on the system.
- ▶ Have a dry CO₂ fire extinguisher adjacent to the charging area and workspace.

The following checks shall be applied to installations and maintenance operations.

- ▶ The actual total refrigerant charge is in accordance with the room size in accordance with Table 1.
- ▶ The ventilation machinery and outlets are operating adequately and are not obstructed.
- ▶ Markings on the equipment are visible and legible.
- ▶ Refrigerant pipes or components are installed in a position where they are unlikely to be exposed to any substance that may corrode refrigerant containing components.

Initial checks of electrical devices shall include the following.

- ▶ that capacitors are discharged in a safe manner to avoid sparking.
- ▶ that no live electrical components and wiring are exposed while charging, recovering or purging the system.
- ▶ That there is continuity to earth bonding.
- ▶ Check that the cabling is not worn, corroded or damaged in any manner.

Electrical repair safety measures

- ▶ All electrical components used or replaced must be to LENNOX's specifications.
- ▶ If a fault exists that could compromise safety, then no electrical supply shall be connected to the circuit until it is satisfactorily dealt with.
- ▶ Sealed electrical components and intrinsically safe components shall be replaced and not repaired.
- ▶ Cabling should be protected from excessive vibration, pressure, sharp edges, and other adverse environmental factors.

Detection of flammable refrigerants

- ▶ Electronic leak detectors shall be used to detect flammable refrigerants, but the sensitivity may not be adequate or may need re-calibration. (Detection equipment shall be calibrated in a refrigerant-free area.)
- ▶ Make sure that the detector is not a potential source of ignition.
- ▶ Leak detection equipment shall be set at a percentage of the LFL (Lower flammable limit) of the refrigerant and shall be calibrated to the refrigerant employed and the appropriate percentage of gas (25% maximum) is confirmed.
- ▶ The use of detergents containing chlorine shall be avoided for cleaning because the chlorine may react with the refrigerant and corrode the piping.
- ▶ If leakage is suspected, naked flames shall be removed.
- ▶ If a leakage is found while brazing, the entire refrigerant shall be recovered from the product or isolated (e.g. using shut-off valves). It shall not be directly released into the environment. Oxygen-free nitrogen (OFN) shall be used for purging the system before and during the brazing process.
- ▶ The work area shall be checked with an appropriate refrigerant detector before and during work.
- ▶ Ensure that the leakage detector is appropriate for use with flammable refrigerants.

Removal and Evacuation

- ▶ When removing refrigerant for servicing it is recommended to remove the entire quantity.
- ▶ When removing refrigerant follow local and national regulations and follow best practices including;
 - evacuate;
 - purge the circuit with inert gas (optional for A2L);
 - evacuate (optional for A2L);
 - continuously flush or purge with inert gas when using a flame to open the circuit; and
 - open the circuit.
- ▶ Use proper recovery cylinders appropriate for the type of refrigerant.
- ▶ Follow prescribed industry best practices for purging and evacuation.
- ▶ Oxygen free nitrogen shall be used for purging the system.

Charging procedure

- ▶ Follow industry standard refrigerant charging best practices.
- ▶ Before recharging the system, it shall be pressure tested with oxygen-free nitrogen gas.
- ▶ Ensure that contamination of different refrigerants does not occur when charging.
- ▶ Cylinders shall be kept in the appropriate position as per instructions.
- ▶ The refrigerant system should be grounded before charging the system.
- ▶ Label the system when charging is completed.
- ▶ Take extreme care not to overfill the refrigeration system.
- ▶ The system shall be leak tested on completion of charging before commissioning.

Safety precautions

Decommissioning

- ▶ Only qualified licensed professionals shall perform refrigerant recovery and decommissioning.
- ▶ Isolate the system electrically.
- ▶ All recovery equipment and cylinders shall conform to appropriate standards. Only approved cylinders, with pressure relief valves, for the type of refrigerant shall be used.
- ▶ Recover refrigerant following industry standard procedure for flammable refrigerants.
- ▶ When draining compressors oil care must be taken that there is no flammable refrigerant in the compressor and that the compressor is not hot. Oil should be handled according to local and federal regulations.
- ▶ After decommissioning, the system shall be labeled stating that it has been decommissioned. The label shall be dated and signed. The label should state that it “contains flammable refrigerant”.
- ▶ Ensure that there are labels on the equipment indicating the equipment contains flammable refrigerant.
- ▶ Recovered refrigerant shall not be mixed or reused. It shall be processed according to national, state and local regulations.

R-32 General Guidelines for Compliance

DISCLAIMER: This section is provided as a general guideline to assist with compliance for VRF- Mini system installations. It is not intended to serve as a substitute for a comprehensive code compliance document. The responsibility for ensuring that all designs, installations, and operations meet applicable regulations, codes, and standards rests solely with the project's licensed engineer or other qualified design professional

Outdoor Unit

Ensure that the outdoor unit is installed outdoors. If installed indoor, additional safety measures may be required to comply with applicable regulations. The outdoor unit includes an external output terminal that can be used to activate safety devices. This terminal outputs a signal if the R-32 sensor in the indoor unit detects a refrigerant leak or if the sensor malfunctions or short-circuits. This signal can be used to trigger required safety measures for the outdoor unit, such as activating a ventilation system or alarm

Indoor Unit

Safety measures should be determined based on the size of the room where the indoor unit is installed and the total R-32 refrigerant charge of the system. Use the instructions in this manual as a guideline to help assess the necessary safety measures. The indoor unit includes an output signal for external devices, which is activated if the R-32 sensor detects a refrigerant leak or if the sensor malfunctions or short-circuits. This signal can be used to activate additional safety devices, such as a ventilation system or alarm. For detailed information on using this function, refer to the indoor unit installation manual.

- ▶ Minimum floor area of the room shall be in compliance with the min. room area according to the total charge of the installation according to Table 1.

Deciding on the required Safety Measures for indoor unit

- ▶ Step 1: Determine the system's total refrigerant charge.
The total refrigerant charge of the system is determined by the sum of the refrigerant charged in the outdoor unit and the additional refrigerant required based on the piping length and indoor unit combination.
- ▶ Step 2: Determine the smallest area of the room the indoor units are installed in.
It includes the room where the indoor unit is directly installed and the room served by the ducted indoor unit. Calculate the area of the room with walls, doors, and partitions excluded.
Spaces connected by false ceilings, ducts, or similar connections are not considered a single space.
- ▶ Step 3: Referring to the total refrigerant charge determined in Step 1, determine the minimum required room area from the table below.
- ▶ Step 4: If the smallest area of the room determined in step 2 is larger than the minimum required room area determined in step 3, no additional measures are necessary. However, if the smallest area of the room determined in step 2 is smaller than that minimum required room area, additional safety measures must be taken (e.g., changing installation conditions, ventilation, shut-off valves).

R-32 General Guidelines for Compliance

<Table 1>

m[lbs(kg)]	Minimum required room area [A, ft ² (m ²)]			
Installation Height[ft(m)]	2(0.6)	5.9(1.8)	7.2(2.2)	8.2(2.5)
≤ 4.061 (1.842)	No requirement			
4.85 (2.2)	258 (23.97)	86 (7.99)	70 (6.54)	62 (5.75)
5.29 (2.4)	281 (26.14)	94 (8.71)	77 (7.13)	68 (6.27)
5.73 (2.6)	305 (28.32)	102 (9.44)	83 (7.72)	73 (6.8)
6.17 (2.8)	328 (30.5)	109 (10.17)	90 (8.32)	79 (7.32)
6.61 (3)	352 (32.68)	117 (10.89)	96 (8.91)	84 (7.84)
7.05 (3.2)	375 (34.86)	125 (11.62)	102 (9.51)	90 (8.37)
7.5 (3.4)	399 (37.04)	133 (12.35)	109 (10.1)	96 (8.89)
7.94 (3.6)	422 (39.22)	141 (13.07)	115 (10.7)	101 (9.41)
8.38 (3.8)	446 (41.39)	149 (13.8)	122 (11.29)	107 (9.93)
8.82 (4)	469 (43.57)	156 (14.52)	128 (11.88)	113 (10.46)
9.26 (4.2)	493 (45.75)	164 (15.25)	134 (12.48)	118 (10.98)
9.7 (4.4)	516 (47.93)	172 (15.98)	141 (13.07)	124 (11.5)
10.14 (4.6)	539 (50.11)	180 (16.7)	147 (13.67)	129 (12.03)
10.58 (4.8)	563 (52.29)	188 (17.43)	154 (14.26)	135 (12.55)
11.02 (5)	586 (54.47)	195 (18.16)	160 (14.85)	141 (13.07)
11.46 (5.2)	610 (56.64)	203 (18.88)	166 (15.45)	146 (13.59)
11.9 (5.4)	633 (58.82)	211 (19.61)	173 (16.04)	152 (14.12)
12.35 (5.6)	657 (61)	219 (20.33)	179 (16.64)	158 (14.64)
12.79 (5.8)	680 (63.18)	227 (21.06)	186 (17.23)	163 (15.16)
13.23 (6)	704 (65.36)	235 (21.79)	192 (17.83)	169 (15.69)
13.67 (6.2)	727 (67.54)	242 (22.51)	198 (18.42)	175 (16.21)
14.11 (6.4)	750 (69.72)	250 (23.24)	205 (19.01)	180 (16.73)
14.55 (6.6)	774 (71.9)	258 (23.97)	211 (19.61)	186 (17.25)
14.99 (6.8)	797 (74.07)	266 (24.69)	218 (20.2)	191 (17.78)
15.43 (7)	821 (76.25)	274 (25.42)	224 (20.8)	197 (18.3)
15.87 (7.2)	844 (78.43)	281 (26.14)	230 (21.39)	203 (18.82)
16.31 (7.4)	868 (80.61)	289 (26.87)	237 (21.98)	208 (19.35)
16.76 (7.6)	891 (82.79)	297 (27.6)	243 (22.58)	214 (19.87)
17.2 (7.8)	915 (84.97)	305 (28.32)	249 (23.17)	220 (20.39)
17.64 (8)	938 (87.15)	313 (29.05)	256 (23.77)	225 (20.92)
18.08 (8.2)	962 (89.32)	321 (29.77)	262 (24.36)	231 (21.44)
18.52 (8.4)	985 (91.5)	328 (30.5)	269 (24.96)	236 (21.96)
18.96 (8.6)	1008 (93.68)	336 (31.23)	275 (25.55)	242 (22.48)
19.4 (8.8)	1032 (95.86)	344 (31.95)	281 (26.14)	248 (23.01)

m[lbs(kg)]	Minimum required room area [A, ft ² (m ²)]			
Installation Height[ft(m)]	2(0.6)	5.9(1.8)	7.2(2.2)	8.2(2.5)
19.84 (9)	1055 (98.04)	352 (32.68)	288 (26.74)	253 (23.53)
20.28 (9.2)	1079 (100.22)	360 (33.41)	294 (27.33)	259 (24.05)
20.72 (9.4)	1102 (102.4)	367 (34.13)	301 (27.93)	265 (24.58)
21.16 (9.6)	1126 (104.58)	375 (34.86)	307 (28.52)	270 (25.1)
21.61 (9.8)	1149 (106.75)	383 (35.58)	313 (29.11)	276 (25.62)
22.05 (10)	1173 (108.93)	391 (36.31)	320 (29.71)	281 (26.14)
22.49 (10.2)	1196 (111.11)	399 (37.04)	326 (30.3)	287 (26.67)
22.93 (10.4)	1219 (113.29)	407 (37.76)	333 (30.9)	293 (27.19)
23.37 (10.6)	1243 (115.47)	414 (38.49)	339 (31.49)	298 (27.71)
23.81 (10.8)	1266 (117.65)	422 (39.22)	345 (32.09)	304 (28.24)
24.25 (11)	1290 (119.83)	430 (39.94)	352 (32.68)	310 (28.76)
24.69 (11.2)	1313 (122)	438 (40.67)	358 (33.27)	315 (29.28)
25.13 (11.4)	1337 (124.18)	446 (41.39)	365 (33.87)	321 (29.8)
25.57 (11.6)	1360 (126.36)	453 (42.12)	371 (34.46)	326 (30.33)
26.01 (11.8)	1384 (128.54)	461 (42.85)	377 (35.06)	332 (30.85)
26.46 (12)	1407 (130.72)	469 (43.57)	384 (35.65)	338 (31.37)
26.9 (12.2)	1431 (132.9)	477 (44.3)	390 (36.24)	343 (31.9)
27.34 (12.4)	1454 (135.08)	485 (45.03)	397 (36.84)	349 (32.42)
27.78 (12.6)	1477 (137.25)	493 (45.75)	403 (37.43)	355 (32.94)
28.22 (12.8)	1501 (139.43)	500 (46.48)	409 (38.03)	360 (33.46)
28.66 (13)	1524 (141.61)	508 (47.2)	416 (38.62)	366 (33.99)
29.1 (13.2)	1548 (143.79)	516 (47.93)	422 (39.22)	372 (34.51)
29.54 (13.4)	1571 (145.97)	524 (48.66)	429 (39.81)	377 (35.03)
29.98 (13.6)	1595 (148.15)	532 (49.38)	435 (40.4)	383 (35.56)
30.42 (13.8)	1618 (150.33)	539 (50.11)	441 (41)	388 (36.08)
30.86 (14)	1642 (152.51)	547 (50.84)	448 (41.59)	394 (36.6)
31.31 (14.2)	1665 (154.68)	555 (51.56)	454 (42.19)	400 (37.12)
31.75 (14.4)	1689 (156.86)	563 (52.29)	461 (42.78)	405 (37.65)
32.19 (14.6)	1712 (159.04)	571 (53.01)	467 (43.37)	411 (38.17)
32.63 (14.8)	1735 (161.22)	579 (53.74)	473 (43.97)	417 (38.69)
33.07 (15)	1759 (163.4)	586 (54.47)	480 (44.56)	422 (39.22)

- m : Total refrigerant charge in the system

- A : Minimum required room area

- ▶ **IMPORTANT:** it's mandatory to consider either the table 1 or taking into consideration the local law regarding the minimum living space of the premises.
- ▶ Minimum installation height of indoor unit is 5.90 ft (1.8 m) for wall, 8.20 ft (2.5 m) for ceiling, 7.22 ft (2.2 m) for ducted, 2.00 ft (0.6m) for floor.

R-32 General Guidelines for Compliance

Flowchart

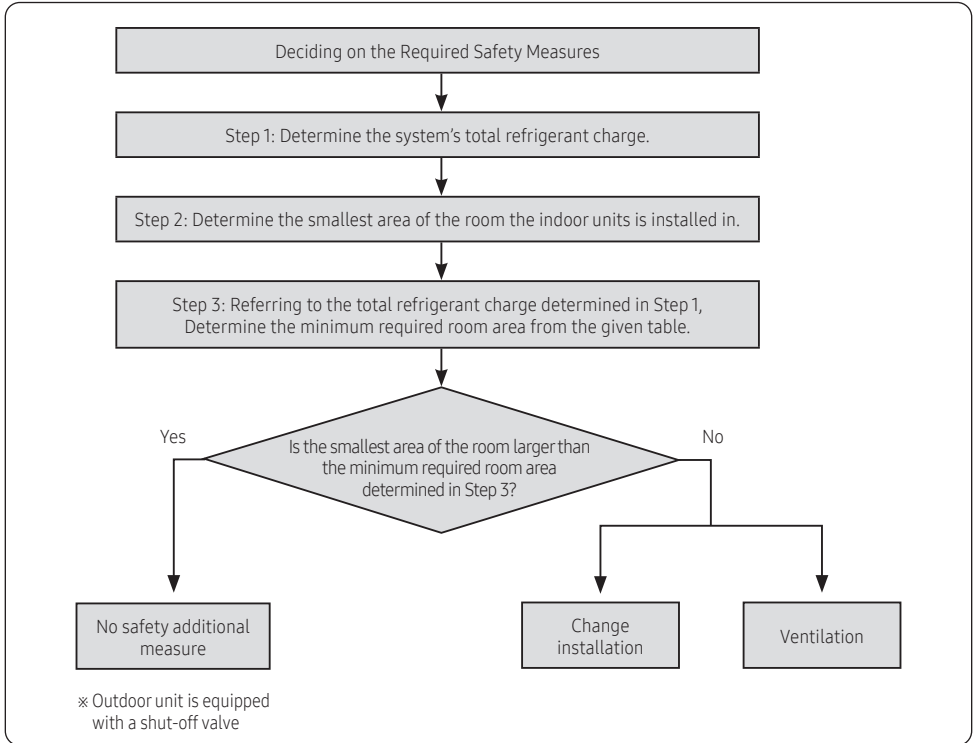

Safety measures

Alarm

The R-32 wired remote controller (VSTAT04P-1) is equipped with a refrigerant leakage alarm.

For details on R-32 wired remote controller with alarm functionality, please refer to the installation and user manual provided with the remote controller.

Change Installation

By changing the installation conditions, the safety measure decision step can be re-executed.

Re-execute the decision step after the following actions:

1. Increase the area of the smallest room where the indoor unit is installed.
2. Reduce the length of the piping to decrease the total refrigerant charge of system.
3. Increase the installation height of the product.

Natural ventilation

Natural ventilation is a safety measure involving ventilation through a large space with enough air to dilute leaked refrigerant.

If natural ventilation is applied, the following conditions must be met:

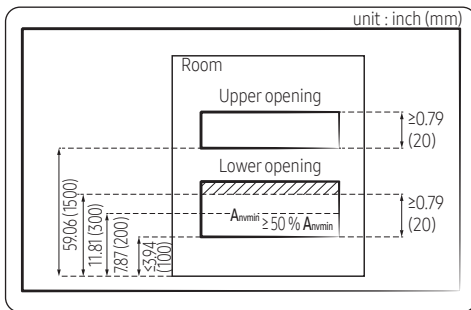

A_{nvmin} Minimal natural ventilation area

Lower opening:

- ▶ Not an opening leading to the outside.
- ▶ Not an opening that can be closed.
- ▶ Area of the opening is $\geq 0.13 \text{ ft}^2$ (0.012 m²) (A_{nvmin}).
- ▶ Area of an opening from the floor that is 12 inch (300 mm) or greater is not included in the calculation of A_{nvmin} .
- ▶ A minimum of 50 % of A_{nvmin} must be located below 8 inch (200 mm) from the floor.
- ▶ The bottom of the lower opening must be located at ≤ 4 inch (100 mm) from the floor.
- ▶ The height of the opening is ≥ 0.78 inch (20 mm).

Upper opening:

- ▶ Not an opening leading to the outside.
- ▶ Not an opening that can be closed.
- ▶ The area of the opening is $\geq 0.065 \text{ ft}^2$ (0.006 m²) (50 % of A_{nvmin}).
- ▶ The bottom of the lower opening must be located at ≥ 59 inch (1500 mm) from the floor.
- ▶ The height of the opening is ≥ 0.78 inch (20 mm).
- ※ Upper opening requirements can be satisfied through false ceilings, ventilation ducts, or similar arrangements for airflow between connected rooms.

Mechanical ventilation

The indoor unit provides an additional output signal for external devices.

This output signal occurs if the R-32 sensor in the indoor unit detects a refrigerant leak, or the R-32 sensor has a malfunction or short circuit.

Based on this signal, an mechanical ventilation system can be activated.

If mechanical ventilation is applied, the following conditions must be met:

- ▶ The upper edge of the air outlet must be located at the same level as or below the refrigerant release point.
- ▶ The mechanical ventilation air extracted from the space must be positioned relative to the mechanical ventilation air intake openings to ensure that the supplementary air mixes with the leaked refrigerant.
- ▶ Required airflow (Please refer to the technical data for the exact required airflow value.)

R-32 General Guidelines for Compliance

Wired remote control general guidelines for compliance (Optional)

For details on wired remote control installation, refer to the installation manual and user manual that came with the wired remote control. This wired remote control serves as a visual/audible warning alarm device in the event of R-32 refrigerant leaks.

Use R-32-capable wired remote controls.

- ※ VSTAT04P-1
- ※ R-32-capable wired remote controls should be purchased separately.



• LENNOX is not responsible for any loss or damage to the product resulting from using anything but the specified wired remote control.

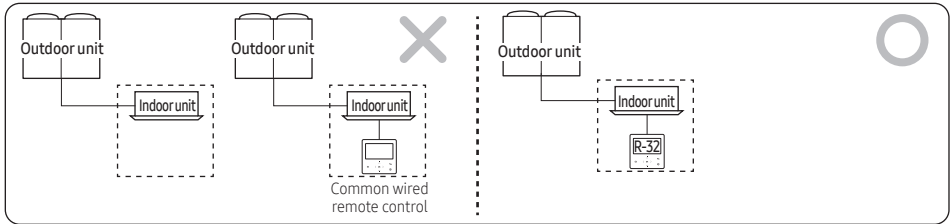

Make sure R-32-capable wired remote controls are located in the same room as the indoor units.

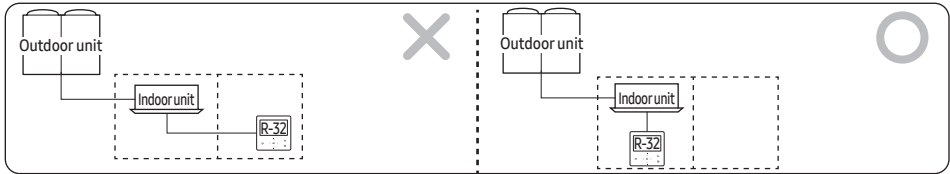

If using two or more R-32-capable wired remote controls, at least one of them must be placed in the same room as the indoor units.

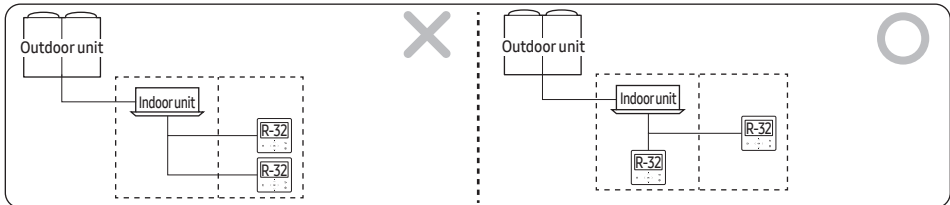

Be sure to connect all indoor units to R-32-capable wired remote controls.

If multiple indoor units are installed in the same room, each indoor unit must be connected to an R-32-capable wired remote control. Make sure that at least one R-32-capable wired remote control is installed in each room.

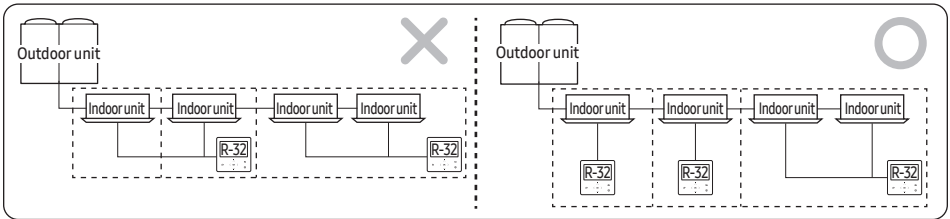
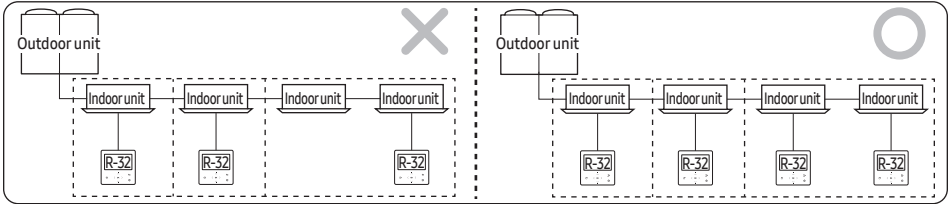

During grouped control, up to 16 indoor units can be connected to a single R-32 wired remote control.

During grouped control and individual control, each indoor unit can be connected to a maximum of two R-32 wired remote controls.

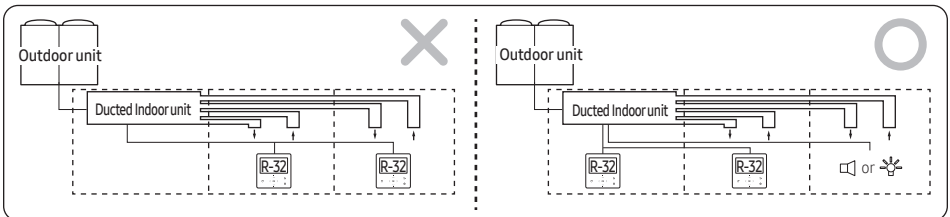

R-32 General Guidelines for Compliance

In case a ducted indoor unit serves a different room than where it is installed, both supply and return air must be directly ducted to that room.

The room area and remote controller rules must be followed for both installed and served room.

If there are more than 3 rooms, install the lamp or alarm device using the indoor unit contact signal.

For the occupancy listed below, the safety alarm system shall also warn at a supervised location, such as the night porter's location, as well as the occupied space:

- ▶ rooms, parts of buildings, building where sleeping facilities are provided,
- ▶ rooms, parts of buildings, building where people are restricted in their movement,
- ▶ rooms, parts of buildings, building where an uncontrolled number of people are present, or
- ▶ rooms, parts of buildings, building to which any person has access without being personally acquainted with the necessary safety precautions.

A wired remote control must be installed in the administrator's room, using wired remote control supervisor mode. For details on how to set wired remote control supervisor mode, refer to the wired remote control installation manual.

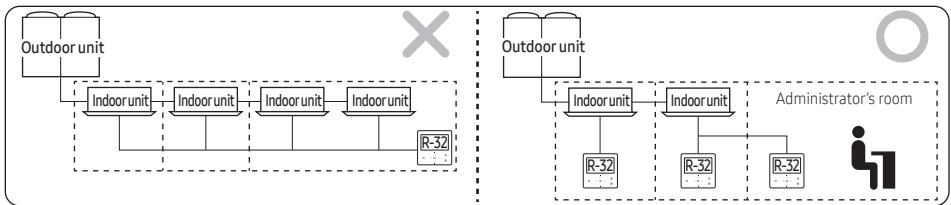

Preparing for installation

Outdoor unit classification

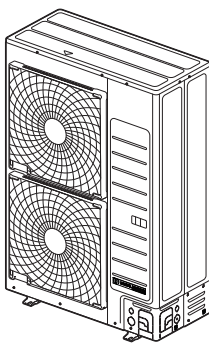
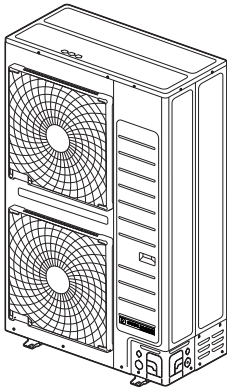
Shape			
		Model	1Ø





Installation combination

- ▶ You must install the indoor units that uses R-32.
- ▶ If sum capacity of the combined indoor units exceeds the capacity of an outdoor unit, the capacity of each indoor unit is reduced below the rated capacity. Therefore, keeping the combination of indoor units within the capacity of an outdoor unit is recommended.

Outdoor unit	Outdoor unit capacity (Ton)	The maximum number of connected indoor units	Total capacity of the connected indoor units [kW(MBH)]
VPD036S6M-5P	3	8	5.6~14.5 (19~49.4)
VPD048S6M-5P	4	9	7.0~18.3 (24~62.4)
VPD060H6M-5P	5	10	8.8~22.8(30~ 78)

Accessories

- ▶ You must keep the following accessories until the installation is finished.
- ▶ Hand over the installation manual to the customer after finishing the installation.

Drain Cap (3) ¹⁾ Drain cap (5) ²⁾	Manual (1)	Drain plug (1)	Rubber Leg (4)
			

¹⁾ VPD036/048S6M-5P

²⁾ VPD060H6M-5P

Preparing for installation

Moving the Outdoor Unit

- ▶ Select the moving route in advance.
- ▶ Be sure that moving route is safe from the weight of the outdoor unit.
- ▶ Do not slant the product more than 30° when carrying it. (Do not lay the product down sideways.)
- ▶ The surface of the heat exchanger is sharp. Be careful not to get injured while moving and installing.

When moving with a crane or wire rope

- ▶ When moving an outdoor unit to a higher place such as the rooftop.
 - Fasten the wire rope as seen in the picture.
 - Move the outdoor unit with the product packed to prevent possible product damage during the transportation.

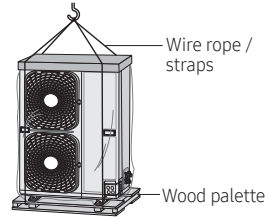

When moving an outdoor unit with hands

- ▶ Moving the outdoor unit by lifting up and carrying due to the short travel distance.
 - Two people should carry the outdoor unit by holding transportation handle.
 - Be careful not to damage the heat exchanger of the rear side of the outdoor unit during transportation.
 - Be careful not to get hurt by the sharp surface of the heat exchanger.

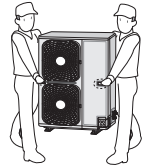

Selecting installation location

Decide the installation location based on the following condition and obtain the user's approval.

- ▶ Avoid a place that may disturb your neighbor. Noise may occur from the outdoor unit and the discharged air may run into the neighborhood. (Be careful of the operation time in a residential area)
- ▶ Install the outdoor unit on a hard and even area that can support its weight.
- ▶ Choose a flat place where rainwater does not settle or leak.
- ▶ Choose a place that will avoid strong winds.
- ▶ Choose a place that is well ventilated and allows enough space for repairs and service. (Discharge duct can be purchased privately.)
- ▶ Choose a place where the connection of refrigerant pipe between an indoor unit and outdoor unit is within allowed distance.
- ▶ Make sure that the condensed water dripping from the drain hose runs out properly and safely.
- ▶ Choose a place where flammable gas does not leak.
- ▶ Choose a place where the unit could not come into contact with snow and rain.
- ▶ When installing the outdoor unit near sea shore, make sure it is not directly exposed to sea breeze.
 - When installing the outdoor unit near sea shore, consult the qualified installer since the places above require additional measures for corrosion resistance. (You should remove salt and dust of a heat exchanger at least once a year.)

Selecting installation location

Installation Guide at the seashore

Make sure to follow below guides when installing at the seashore.

1. Do not install the product in a place where it is directly exposed to sea water and sea breeze.
 - Make sure to install the product behind a structure (such as building) that can block sea breeze.
 - Even when it is inevitable to install the product in seashore, make sure that product is not directly exposed to sea breeze by installing a protection wall.
2. Consider that the salinity particles clinging to the external panels should be sufficiently washed out.
3. Because the residual water at the bottom of the outdoor unit significantly promotes corrosion, make sure that the slope does not disturb drainage.
 - Keep the floor level so that rain does not accumulate.
 - Be careful not to block the drain hole due to foreign substance
4. When product is installed in seashore, periodically clean it with water to remove attached salinity.
5. Make sure to install the product in a place that provides smooth water drainage. Especially, ensure that the base part has good drainage.
6. If the product is damaged during the installation or maintenance, make sure to repair it.
7. Check the condition of the product periodically.
 - Check the installation site every 3 months and perform anti-corrosion treatment such as R-Pro supplied by LENNOX or commercial water repellent grease and wax, etc., based on the product condition.
 - When the product is to be shut down for a long period of time, such as off-peak hours, take appropriate measures like covering the product.
8. If the product installed within 1640.42 ft (500 m) of seashore, special anti-corrosion treatment is required.
 - ※ Please contact your local LENNOX representative for further details.

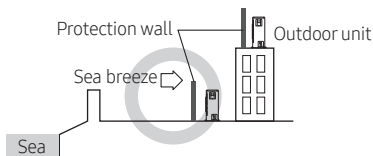
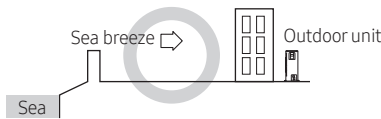
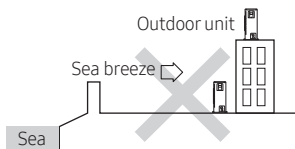

- ※ Protection wall should be constructed with a solid material such as concrete to block the sea breeze and the height and the width of the wall should be 1.5 times larger than the size of the outdoor unit. (Also, allow over 27.56 inch (700 mm) space between the protection wall and the outdoor unit for ventilation of exhaust air.)

Space requirement for installation



- Install the indoor unit away from any interfering sources such as radio, computer, stereo equipment and also select a place where the electrical wiring work and an indoor unit installation are possible.
 - Especially keep the unit at least 9.84 ft (3 m) away from the electrical equipment in an area where weak electromagnetic waves are generated and install the protection tube to protect the main power cable and communication cable.
 - Make sure that there is no equipment that generates electromagnetic waves. If so, malfunction of the control system may occur due to the effect of the electromagnetic wave. (For example: The remote control sensor of the indoor unit may not have good reception in an area with fluorescent lamp style lighting.)
- Make sure the outdoor unit is installed in a safe place where it will not be obstructed by snowfall. The frame should be installed in a place where the air inlet and heat exchanger of the unit are not buried in the snow.
- R-32 refrigerant is slightly flammable. Therefore, a ventilation device is required if the outdoor unit is installed indoors or in an enclosed area.
- Install railing around the outdoor unit to prevent it falling when the unit is installed on a high place such as the roof of the building.
- Avoid installing the units in places near an exhaust pipe and ventilating opening exposed to corrosive gas, oxides of sulfur, ammonia gas or sulfur gas herbicides. (These places need additional anticorrosive treatments. Please contact manufacture to avoid corroding copper pipes or soldered parts.)
- There shouldn't be any inflammable material such as wood and oil around the indoor unit. Otherwise, external fire may spread to the product.
- According to the condition of power supply, electric noise or unstable voltage can occur malfunction of electric parts or control system. (At the ship or places using power supply from electric generator... etc)

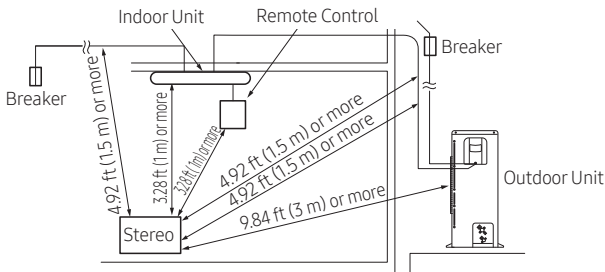

- ▶ Make sure that the water dripping from the drain hose runs away correctly and safely.
- ▶ You should repaint or protect the damaged part so that the paint of the cabinet does not peel off and become rusty during installation. When the cabinet becomes rusty, the life of an outdoor will be reduced.

Space requirement for installation

- ▶ Make a space for ventilation and service as seen in the picture.
 - ▶ When multiple outdoor units are combined for installation, allow enough space for ventilation against a wall. If the ventilation space is not allowed, product malfunction may occur.
 - ▶ The side with logo is the front side of the outdoor unit.
- ※ Figure Description

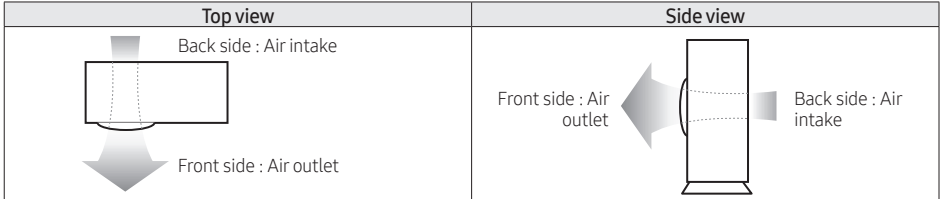

- Air flow direction.

When installing 1 outdoor unit

Unit : inch (mm)

- ※ When the air outlet is opposite the wall

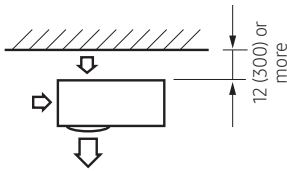

- ※ When the air outlet is toward the wall

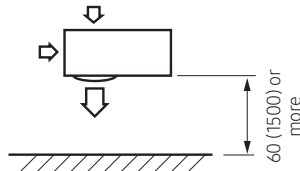

- ※ When 3 sides of the outdoor unit are blocked by the wall

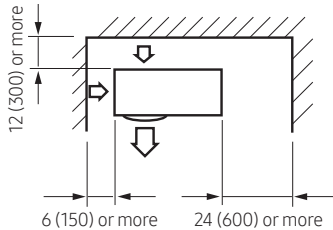

- ※ The upper part of the outdoor unit is blocked and the air outlet is toward the wall

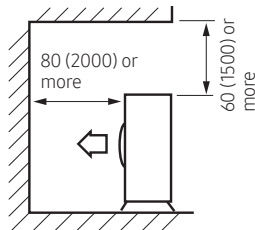

- ※ The upper part of the outdoor unit is blocked and the air outlet is opposite the wall

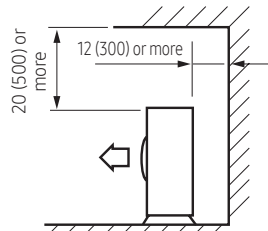

- ※ When the walls are blocking front and the rear of the outdoor unit

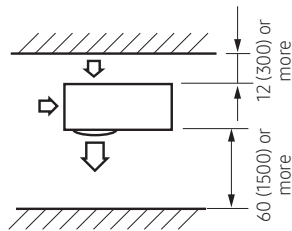

When installing more than 1 outdoor unit

※ When 3 sides of the outdoor unit are blocked by the wall

Unit : inch (mm)

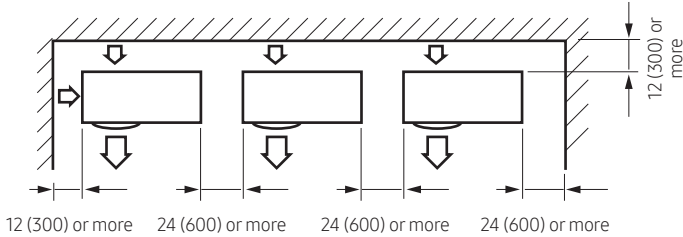

※ When the walls are blocking front and the rear of the outdoor units

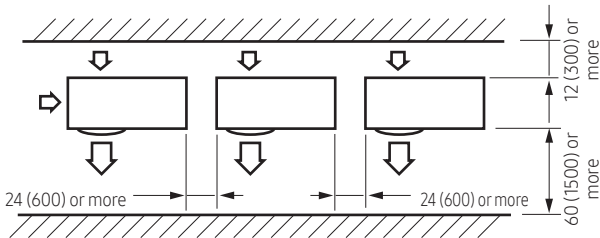

※ When front and rear side of the outdoor unit is toward the wall

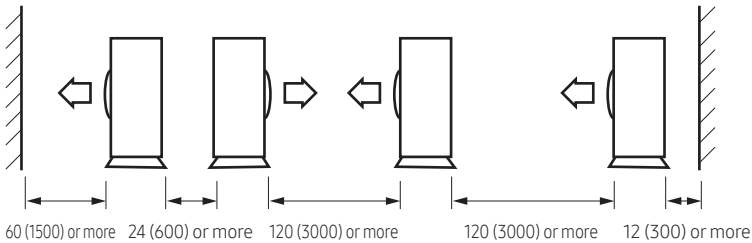

• Should adopt bar type louver. Don't use a type of rain resistance louver.

[Bar type louver]



[Rain resistance louver]

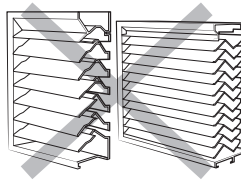

• Louver specifications.

- Angle criteria : less than 20°
- Opening ratio criteria : greater than 80%

Installation and base ground work for an outdoor unit

- ▶ Install the outdoor unit 5.91 inch (150 mm) higher than the base ground and install the drain hole to connect the pipe to the drainage.
- ▶ When the front fan of an outdoor unit is installed in a place where the average snowfall is more than 5.91 inch (150 mm), the discharge duct should be attached to the outdoor unit.
- ▶ The concrete foundation should be 1.5 times larger than bottom of the outdoor unit.
- ▶ It is necessary to install wire mesh or steel bar when outdoor units are installed on a soft foundation.
- ▶ When installing multiple outdoor units at the same place, install the H beam on the base ground. (When installing a number of outdoor units, you can install it on the base ground.)
- ▶ Install the H beam (5.91 inch (150 mm) x 5.91 inch (150 mm) x t10 : basic specification) or vibration absorption frame to jut out from the base ground.
- ▶ After installing the H beam, apply corrosion protection.
- ▶ Install a square pad (t=0.79 inch (20 mm) or more) to prevent vibration from the outdoor unit onto the base ground. Place the outdoor unit on the H beam and fix it with the bolt, nut and washer. (Fix with M10 basic anchor bolt, nut and washer.)

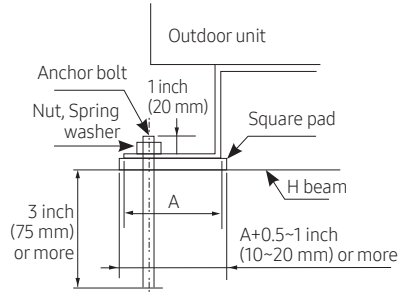

Base ground work

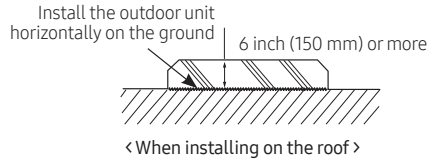
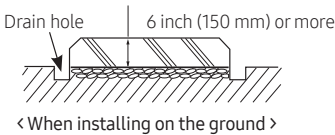

- ▶ The outdoor unit should be supported within the range of measurement below for base ground work.

Unit : inch (mm)

- VDP036/048S6M-5P

- VDP060H6M-5P

Anchor bolt position

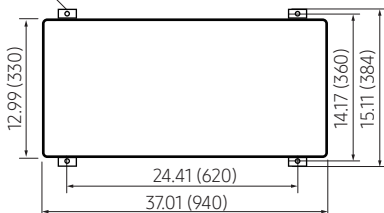

Anchor bolt position

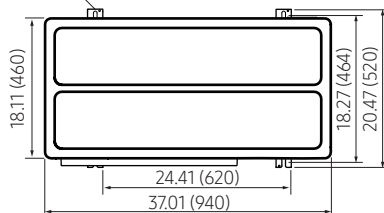

-
- When the outdoor unit needs to be supported, fix it with wire as shown in the picture.
- Slightly unwind the four screws on the cover top of the outdoor unit.
 - Wind wires round the four screws and fasten the screws again.
 - Fix the wires to the ground.

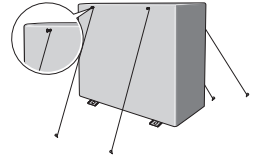

CAUTION

- If the outdoor unit is not fixed securely, product may fall and it might cause loss of life or property damage.
- Do not install the outdoor unit on a wood palette.
- Fix the outdoor unit securely to the base ground with anchor bolts.
- The manufacturer is not responsible for the damage occurred by not adhering to the standard of the installation.
- To protect the outdoor unit from external condition such as rain, install it on the base ground and connect the drain pipe to the drainage.

Refrigerant pipe installation

Refrigerant pipe work

- ▶ The length of refrigerant pipe should be as short as possible and the height difference between an indoor unit and outdoor unit should be minimized.
- ▶ The piping length between the outdoor unit and the indoor unit may not exceed the allowable piping length, height difference, and the allowable length after branching is done.
- ▶ The pressure of the R-32 is high. Use only certified refrigerant pipe and follow the installation method.
- ▶ After pipe installation, charge the refrigerant according to the length of the pipe and R-32 refrigerant should be used.
- ▶ Use clean refrigerant pipe and there shouldn't be any harmful ion, oxide, dust, iron content or moisture inside pipe.
- ▶ Use tools and accessories designed for R-32.



- When installing, make sure there is no leakage. When collecting the refrigerant, stop the compressor first before removing the connection pipe. If the refrigerant pipe is not properly connected and the compressor works with the service valve open, the pipe inhales the air and it makes the pressure inside of the refrigerant cycle abnormally high. It may cause explosion and injury.

Tool	Work		If compatible with conventional tool
Pipe cutter	Refrigerant pipe work	Pipe cutting	Compatible
Flaring tool		Pipe flaring	
Refrigerant oil		Apply refrigerant oil on flared part	Exclusive ether oil, ester oil, alkali benzene oil or synthetic oil
Torque wrench		Connect flare nut with pipe	Compatible
Pipe bender	Pipe bending		
Nitrogen gas	Air tightening test	Inhibition of oxidization	
Brazing tool		Pipe brazing	
Manifold gauge	Air tightening test ~ additional refrigerant charging	Vacuuming, charging and checking operation	Need exclusive one to prevent mixture of R-22 refrigerant oil use and also the measurement is not available due to the high pressure.
Refrigerant charging hose			Need exclusive one due to the refrigerant leakage or inflow of impurities.
Vacuum pump	Vacuum drying		Compatible (Use products which contain the check valve to prevent the oil from flowing backward into the outdoor unit.) Use the one that can be vacuum up to 100.7kpa(5Torr.-755mmHg).
Scale for refrigerant charging	Charging refrigerant		Compatible
Gas leak detector	Gas leak test		Need exclusive one (The one for R-134a can be used)
Flare nut	You must use the flare nut equipped with product.		

Temper grade and minimum thickness of the refrigerant pipe

Outer diameter [inch (mm)]	Minimum thickness [inch (mm)]	Temper grade
Ø1/4(6.35)	0.028 (0.7)	Annealed
Ø3/8(9.52)	0.028 (0.7)	
Ø1/2(12.70)	0.031 (0.8)	
Ø5/8(15.88)	0.039 (1.0)	
Ø3/4(19.05)	0.035 (0.9)	Drawn
Ø7/8(22.22)	0.035 (0.9)	

Selecting refrigerant pipe and branch joint for Heat Pump

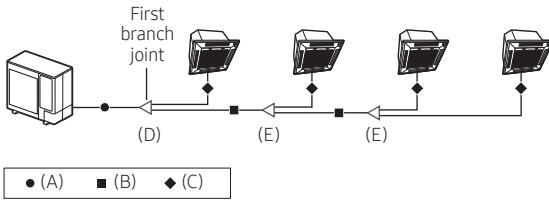

- ▶ Install the refrigerant pipe according to the main pipe size of each outdoor unit capacity.
- ▶ When the pipe length between an outdoor unit and the farthest indoor unit including elbow exceeds 295.28 ft (90 m), the gas pipe size should be upgraded one step among the main pipes from the outdoor unit to the first branch joint. (The liquid pipe size will be maintained.)
- ▶ If the capacity of the outdoor unit can decline due to the pipe length, upgrade the pipe size one step (gas pipe).
- ※ For the case that the diameter of the default pipe of an outdoor unit does not match that of the pipe installed on the site, use a socket provided by default together with the outdoor unit of 4/5 HP.

The size of the pipe between an outdoor unit and the first branch joints (A)

Select the size of the main pipe according to the table below.

Outdoor unit capacity (Ton)	Maximum pipe length within 295.28 ft (90 m)		Maximum pipe length over 295.28 ft (90 m)	
	Liquid pipe [inch (mm)]	Gas pipe [inch (mm)]	Liquid pipe [inch (mm)]	Gas pipe [inch (mm)]
3	ø3/8(9.52)	ø5/8(15.88)	ø3/8(9.52)	ø3/4 (19.05)
4	ø3/8(9.52)	ø5/8(15.88)	ø3/8(9.52)	ø3/4 (19.05)
5	ø3/8(9.52)	ø3/4 (19.05)	ø3/8(9.52)	ø7/8(22.22)

* Maximum pipe length : The pipe length between an outdoor unit and the farthest indoor unit.

Refrigerant pipe installation

The size of the pipe between the branch joints (B)

Select the pipe size according to the sum of indoor unit capacity which will be connected after the branch.

- ※ However, if the size of the pipe between branch joints (B) is bigger than the size of the pipe connected to the outdoor unit (A), apply the pipe size (A).

Indoor unit capacity [kW(Btu/h)]	Branch pipe length within 147.64 ft (45 m)		Branch pipe length between 147.64~295.28 ft (45~90 m)	
	Liquid [inch(mm)]	Gas [inch(mm)]	Liquid [inch(mm)]	Gas [inch(mm)]
Capacity < 5.7(19500)	Ø1/4(6.35)	Ø1/2(12.70)	Ø3/8(9.52)	Ø5/8(15.88)
5.7(19500) ≤ Capacity < 16(54600)	Ø3/8(9.52)	Ø5/8(15.88)	Ø1/2(12.70)	Ø3/4(19.05)
16(54600) ≤ Capacity		Ø3/4(19.05)		Ø7/8(22.22)

The size of the pipe between the branch joint and the indoor unit (C)

Select according to the capacity of the indoor unit.

Indoor unit capacity [kW(Btu/h)]	Liquid [inch(mm)]	Gas [inch(mm)]
Capacity ≤ 6 (20500)	Ø1/4(6.35)	Ø1/2(12.70)
6(20500) < Capacity ≤ 16(54600)	Ø3/8(9.52)	Ø5/8(15.88)
16(54600) < Capacity ≤ 23(78500)	Ø3/8(9.52)	Ø3/4(19.05)

Selecting the first branch joint (D)

Select according to the sum of the capacity of the outdoor unit.

Classification	Outdoor unit capacity (Ton)	Model name
Y-joint (D)	3	V1IDBP01PR
	4	V1IDBP01PR
	5	V1IDBP02PR

Selecting the other branch joints (E)

Select a branch joint according to the sum of indoor unit capacity which will be connected after the branch.

- ※ However, if the branch joints (E) is bigger than the first branch joint (D), apply the branch joint of the same size as the first branch joint (D).

Classification	Indoor unit capacity [kW(Btu/h)]	Model name
Y-joint (E)	Capacity < 16(54600)	V1IDBP01PR
	16(54600) ≤ Capacity	V1IDBP02PR
Distribution header (E)	Capacity < 50.4(170000) (for 4 rooms)	V1HDRK11PR

- ※ If the criteria for selecting the branch in the outdoor installation manual and the branch installation manual are different, please select the branch in accordance with the outdoor installation manual.

Keeping refrigerant pipe

To prevent foreign materials or water from entering the pipe, storing method and sealing method (especially during installation) is very important. Apply correct sealing method depending on the environment.

Exposure place	Exposure time	Sealing type
Outdoor	Longer than one month	Pipe pinch
	Shorter than one month	Taping
Indoor	-	Taping

Refrigerant pipe welding and safety information



Important information for refrigerant pipe work

- Make sure there is no moisture inside the pipe.
- Make sure there are no foreign substances and impurities in the pipe.
- Make sure there is no leakage.
- Make sure to follow the instruction when welding or storing the pipe.

Nitrogen flushing when brazing

- ▶ When brazing the refrigerant pipes, flush them with nitrogen gas as shown in the picture.
- ▶ If you do not perform nitrogen flushing when brazing the pipes, oxide may form inside the pipe. It can cause the damage of the important parts such as compressor and valves etc.
- ▶ Adjust the flow rate of the nitrogen flushing with a pressure regulator to maintain 2-3 psi or less.

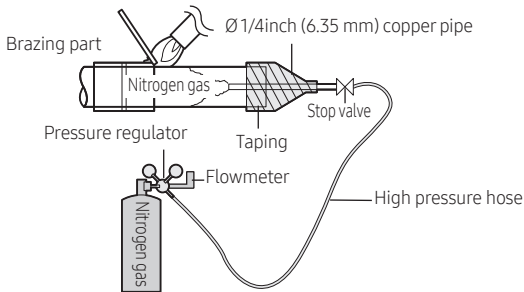

Refrigerant pipe installation

Direction of the pipe when welding

- ▶ Direction of the pipe should be headed downward or in a sideways when brazing.
- ▶ Avoid brazing the pipe with pipe direction heading upward.



- When you test gas leakage after brazing the pipes, use a designated solution for gas leakage detection. If you use the detection solution that includes sulfuric ingredient, it may cause corrosion to the pipes.

Cutting or flaring the pipes

1. Make sure that you prepared the required tools.
 - ▶ Pipe cutter, Deburring tool, flaring tool and pipe holder, etc.
2. If you want to shorten the pipe, cut it with a pipe cutter ensuring that the cut edge remains at 90° with the side of the pipe.
 - ▶ Refer to below illustrations for correct and incorrect examples of cut edges.

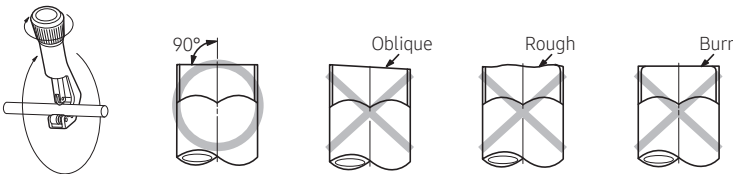

3. To prevent a gas leak, remove all burrs at the cut edge of the pipe using a Deburring tool.
4. Carry out flaring work using flaring tool as shown below.

[Flaring tools]

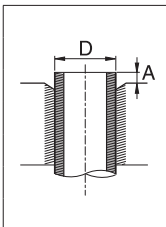
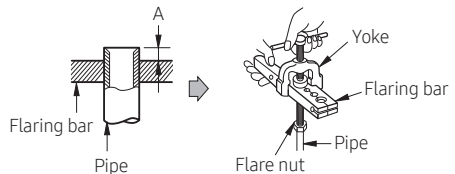
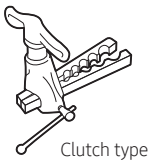

Pipe diameter [inch(mm)]	A [inch(mm)]		
	Flare tool for R-32	Conventional flare tool	
		Clutch type	Clutch type Wing nut type
Ø1/4(6.35)	0~0.776(0~0.5)	0.039~0.059(1.0~1.5)	0.059~0.079(1.5~2.0)
Ø3/8(9.52)	0~0.776(0~0.5)	0.039~0.059(1.0~1.5)	0.059~0.079(1.5~2.0)
Ø1/2(12.70)	0~0.776(0~0.5)	0.039~0.059(1.0~1.5)	0.059~0.079(1.5~2.0)
Ø5/8(15.88)	0~0.776(0~0.5)	0.039~0.059(1.0~1.5)	0.059~0.079(1.5~2.0)

5. Check that you flared the pipe correctly.

▶ Refer to below illustrations for correct and incorrect examples of flared pipe.

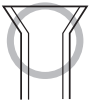

Correct



Inclined



Damaged Surface



Cracked



Uneven Thickness



- If foreign matters or burrs are not removed after cutting pipe, refrigerant gas may leak.
- If foreign matters enter inside the pipe, important interior parts of the unit may get damaged or product efficiency will be reduced. So, the direction of pipe should be downward during pipe cutting or flaring.

Connecting the flared pipes

- ▶ Check if the flaring is properly done according to the standard size.
- ▶ Align the center of the piping and tighten the flare nut with your hands. Then, tighten the flare nut with torque wrench in a direction of the arrow indicated in below illustration.
- ▶ Make sure to use ester oil to coat the flare connection section.

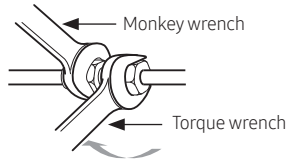
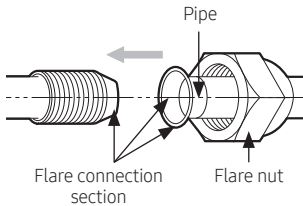

Outer diameter [D, inch(mm)]	Connection torque		Flare dimension [L, inch(mm)]	Flare shape [inch(mm)]
	kgf•cm	N•m		
Ø1/4(6.35)	140~180	14~18	0.343~0.358(8.70~9.10)	
Ø3/8(9.52)	350~430	34~42	0.504~0.520(12.80~13.20)	
Ø1/2(12.70)	500~620	49~61	0.638~0.654(16.20~16.60)	
Ø5/8(15.88)	690~830	68~82	0.760~0.776(19.30~19.70)	



- Blowing Nitrogen gas should be done when brazing the pipe.
- Make sure to use the provided flare nut.
- Make sure that there are no cracks or twisted part when you need to bend the pipe.
- Do not fasten the flare nut with excessive strength.
- R-32 is a high pressure refrigerant and there is a risk of refrigerant leakage if the flare connection is not coated with ester oil. Therefore, apply ester oil to coat the flare connection area.

Refrigerant pipe installation

Pipe installation for an outdoor unit

Pipe direction

The refrigerant pipe can be pulled out from front, flank, rear, and bottom side, so install it depending on the installation site condition.



Caution for using knock-out hole

- Make sure not to damage the exterior of the outdoor unit.
- Remove all burrs at the edge of the knock-out hole and apply the paints it to prevent rust.
- Use a cable tube and bushing to prevent a cable from being damaged when passing through a knock-out hole.
- After installing pipes, block the unused knock hole to prevent small animal from entering. However, the radiant heat hole (A) should be able to intake air.

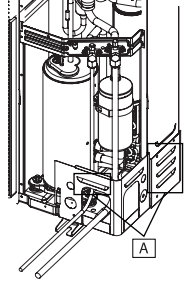

Caution for connecting the pipe

- When brazing the pipe, the unit may get damaged by a brazing fire and a flame. Use a flame proofing cloth to protect the unit from a brazing fire or flame.
- The O-ring and Teflon packing inside service valve may get damaged by a brazing fire. Wrap the bottom side of the service valve with a wet cloth and braze it as shown above. Make sure not to interrupt the brazing with the drips from the wet cloth.
- The connecting pipes of liquid side and gas side should not contact each other nor should they contact to the product. Vibration may cause damage to the pipes.

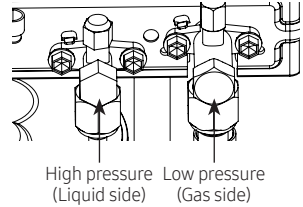

Outdoor unit refrigerant pipe connection

Classification	Front, side, back side of pipe connection	Bottom side of pipe connection
Working process	<ul style="list-style-type: none"> • First, remove the pipe cover from unit. • Separate the knock-out hole to use. If the hole is open, small animals such as squirrels and rats may get into the unit through the hole and the unit may be damaged. 	<ul style="list-style-type: none"> • Separate the knock-out hole at the bottom side of the unit and install the pipe. • After installing and insulating the pipe, close up the remaining gap. If the gap remains open, small animals such as rats and squirrels may get inside the unit and cause damage to the unit.

Installing the branch joints

Branch joints must be installed 'horizontally' or 'vertically'.

Horizontal installation

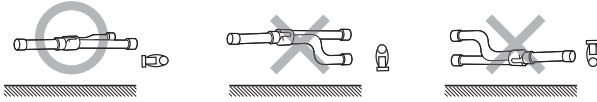

Vertical installation

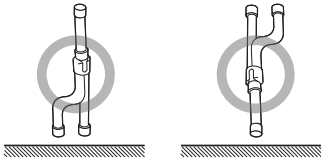

- For A~J type branch joints : Connect the branch joint to the connection pipe with the provided reducer.
- For K~Z type branch joints : Cut the connection part of the branch joint or the provided socket, according to the diameter of the connection pipe, before connecting them.

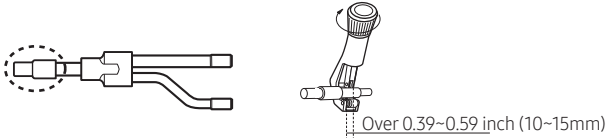

- Install the branch joint within $\pm 15^\circ$ of the horizon or vertical line.
- Make sure that the pipe is not bent at where it is connected to the branch joint.
- Keep a minimum straight line distance of 20inch (500mm) or more before connecting branch joint.

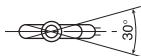
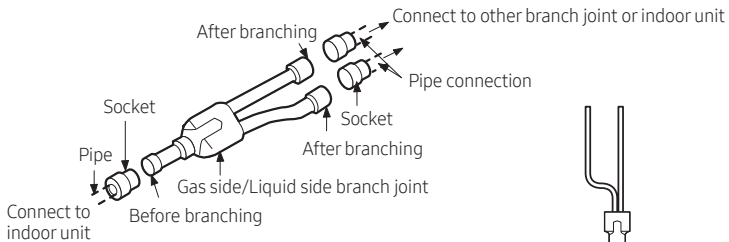

- ※ Install within $\pm 15^\circ$ of the horizon or vertical line.

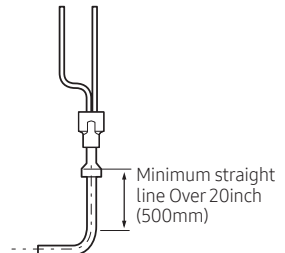

Refrigerant pipe installation

Installing the distribution header

1. Select the reducer that fits the diameter of the pipe.

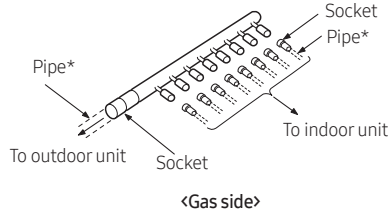
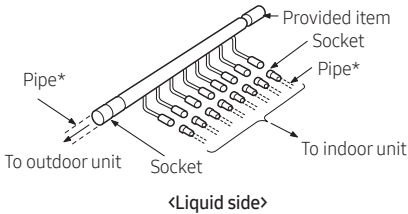

* Pipe : Separately purchased item

2. If the number of connected indoor unit is fewer than ports on the distribution header, block the unused ports with caps.

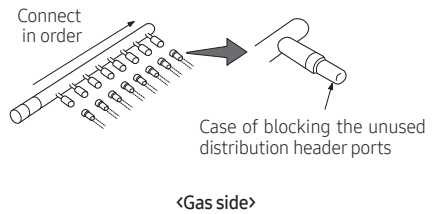
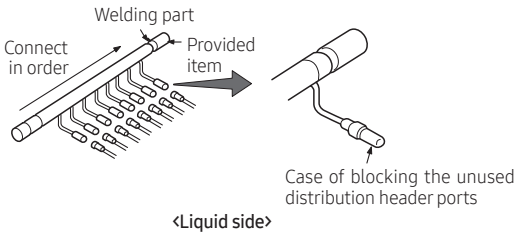

- For A~J type distribution header :
Connect the distribution header to the connection pipe with the provided reducer.
- For K~Z type distribution headers :
Cut the provided socket, according to the diameter of the connection pipe, before connecting it.

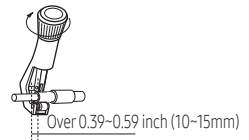
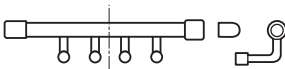

- Connect the indoor units in order, while respecting the direction of the arrow shown in the illustration.
- When indoor units are connected to same distribution head, indoor unit must be connected in order of their capacity, from largest to smallest.

3. Install the distribution header horizontally.

- ▶ Install the distribution header horizontally so that its ports does not face down.

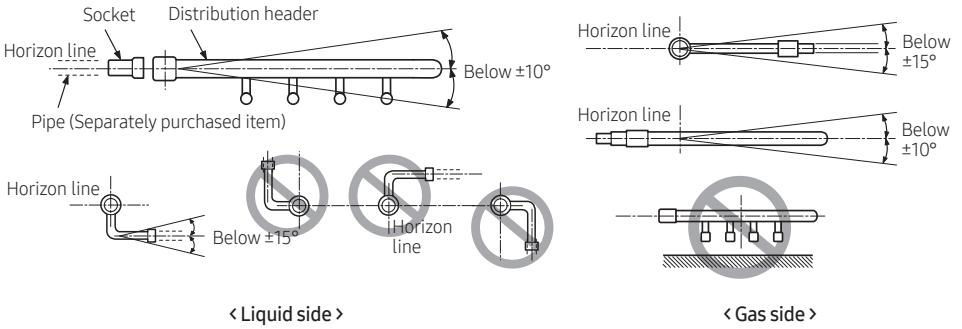

Examples of the refrigerant pipe installation for Heat Pump

Using Y-Joint

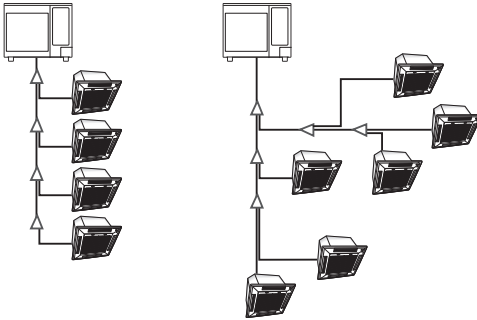

Using Distribution header

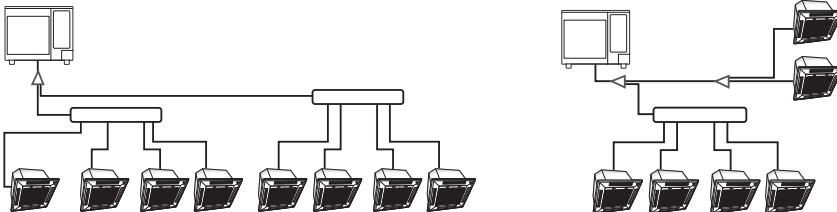

Refrigerant pipe installation

Allowable length of the refrigerant pipe and the installation examples for Heat Pump

Connection by Y-joint

Outdoor unit

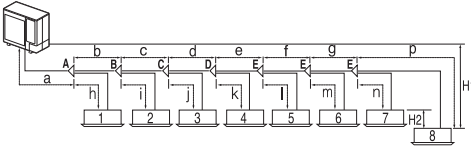

Classification		Y-joint connection	
Maximum allowable length of pipe	Outdoor unit ~ Indoor units	Actual Length	The distance between the outdoor unit and the farthest indoor unit $\leq 492\text{ft}$ (150m) Ex) 8 indoor units $a+b+c+d+e+f+g+p \leq 492\text{ft}$ (150m)
		Equivalent length	The distance between an outdoor unit and the farthest indoor unit $\leq 574\text{ft}$ (175m)
		Total length	The sum of the total length of pipes should be less than 984ft (300m).
Maximum allowable height	Outdoor unit ~ Indoor units	Height	H1: The difference of height between an outdoor unit and indoor unit $< 164/131\text{ft}$ (50/40m) ^{Note 1)}
		Height	Height H2: The difference of height between indoor units $\leq 49\text{ft}$ (15m)
Maximum allowable length after Y-joint		Actual Length	The distance between the first Y-joint and the farthest indoor unit $\leq 131\text{ft}$ (40m) Ex) 8 indoor units $b+c+d+e+f+g+p \leq 131\text{ft}$ (40m)

- ※ When the equivalent length between an outdoor unit and the farthest indoor unit exceeds 295.28ft (90m), upgrade the low pressure pipe of the main pipe one step.
- ※ Note 1) When indoor unit is located at higher level than outdoor unit, allowable height difference is 131ft (40m), but when the indoor unit is located at lower level than outdoor unit, allowable height difference is 164ft (50m).

Connection by Distribution header

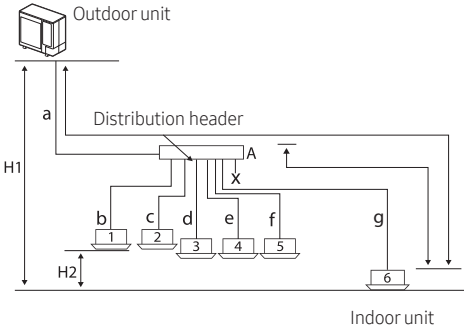

Connection by Y-joint/Distribution header

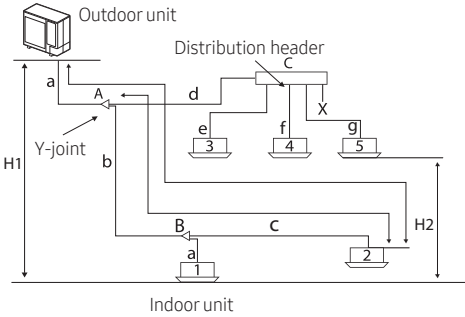

Classification		Distribution connection	Y-joint / Distribution connection
Maximum allowable length of pipe	Outdoor unit ~ Indoor units	Actual Length	The distance between an outdoor unit and the farthest indoor unit $\leq 492\text{ft}$ (150m) Ex) 8 indoor units $a+g \leq 492\text{ft}$ (150m)
		Equivalent length	The distance between an outdoor unit and the farthest indoor unit $\leq 574\text{ft}$ (175m)
		Total length	The sum of total length of pipes should be less than 984ft (300m)
Maximum allowable height	Outdoor unit ~ Indoor units	Height	H1: The difference in height between an outdoor unit and indoor unit $< 164/131\text{ft}$ (50/40m) ^{Note 1)}
		Height	H2: The difference in height between indoor units $\leq 49\text{ft}$ (15m)
Maximum allowable length after Y-joint		Actual Length	The distance between the header joint and the indoor unit $\leq 131\text{ft}$ (40m) Ex) b, c ~ f, g $\leq 131\text{ft}$ (40m)
			The distance between the first Y-joint and the farthest indoor unit $\leq 131\text{ft}$ (40m) Ex) 8 indoor units b+c, d+g $\leq 131\text{ft}$ (40m)

- ※ When the equivalent length between an outdoor unit and the farthest indoor unit exceeds 295.28ft (90m), upgrade the low pressure pipe of the main pipe one step.
- ※ Note 1) When indoor unit is located at higher level than outdoor unit, allowable height difference is 131ft (40m), but when the indoor unit is located at lower level than outdoor unit, allowable height difference is 164ft (50m).

Refrigerant pipe installation

Performing air tightening test

- ▶ Use tools for R-32 only to prevent the inflow of foreign substances and to resist the internal pressure.
- ▶ Use dry Nitrogen gas to do an airtight test as below.

Apply pressure to the liquid side pipe, gas side pipe with Nitrogen gas of 595 psi (gauge pressure).

If you apply pressure more than 595 psi (gauge pressure), the pipes may be damaged. Apply pressure using pressure regulator.

Continue to apply pressure for minimum 24 hours to check if the pressure drops or follow local rules.

After applying Nitrogen gas, check the change of pressure using pressure regulator.

If the pressure drops, check if there is a gas leak.

If the pressure is changed, apply soapy water to check the leak. Check the pressure of the gas again.

Maintain 145 psi (gauge pressure) of the pressure before performing vacuum drying and check for further gas leak.

After checking first gas leak, maintain 145 psi (gauge pressure) to check for further gas leaks.

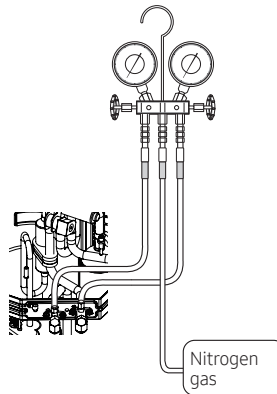

- If the joint of high pressure side is disconnected and the nitrogen gas come into contact with human body, injury may occur. Tighten the joint connection firmly to prevent dangerous situation.

Vacuumping a pipe and an indoor unit

- ▶ Use the tools for R-32 only to prevent the inflow of foreign substances and resist against the internal pressure.
- ▶ Use the vacuum pump with the check valve to prevent pump oil from flowing backward while the vacuum pump is stopped suddenly.
- ▶ Use the vacuum pump that can be vacuumed up to 666.6Pa(5mmHg).
- ▶ Close the service valve of the liquid side pipe, gas side pipe completely when performing air tightening test or vacuum drying.

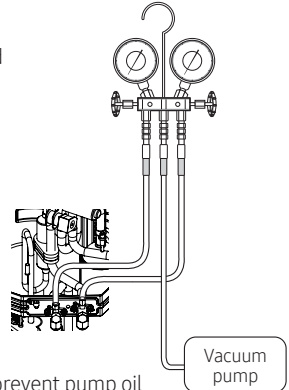

Connect the manifold gauge to the liquid pipe and gas pipe.

Vacuum the liquid pipe and gas pipe using the vacuum pump.

Make sure to install check valve to prevent pump oil from flowing into the pipe.

Vacuum those pipes for more than 2 hours and 30 minutes.

The time of vacuum drying may differ depending on the length of the pipe or outdoor temperature. Perform vacuum drying for at least 2 hours and 30 minutes.

Close the valve after checking the vacuum gauge pressure has reached at -100.7 kPa (gauge pressure).

Check the vacuum pressure using the vacuum gauge.

Check whether the pressure is maintained as -100.7 kPa (gauge pressure), 5 torr. for an hour.

Pressure Increase

Yes

No

Charging additional refrigerant according to piping length

Check the gas leak.

Vacuum destruction due to the moisture inside the pipe

- Apply pressure with Nitrogen gas of 0.05 MPa (gauge pressure).

Perform vacuum drying again up to -100.7 kPa (gauge pressure), 5 torr (for 2 hours or longer) and evaluate the vacuum

Pressure Increase

No

Yes



- If the pressure rises in an hour, either water remains inside the pipe, or there will be a leak.

Refrigerant pipe installation

Selecting additional refrigerant charging

► Basic refrigerant

The basic amount of refrigerant charged at a factory

Model	Refrigerant	Factory charge [lbs(kg)]
VPD036S6M-5P	R-32	6.61(3.0)
VPD048S6M-5P		6.61(3.0)
VPD060H6M-5P		8.38(3.8)

► Charging additional refrigerant

The amount of additional refrigerant charging	=	The amount of refrigerant charging for pipe + the amount of refrigerant correction charging for an indoor unit.
---	---	--

1. The amount of additional refrigerant depending on the liquid pipe size(HP/HR).

- Amount of additional refrigerant has to be calculated based on the sum of all liquid pipe length.

Size of liquid pipe [inch(mm)]	1/4(6.35)	3/8(9.52)	1/2(12.7)	5/8(15.88)
Additional amount [kg/m (lb/ft)]	0.013(0.02)	0.037(0.055)	0.077(0.115)	0.111(0.165)

Additional refrigerant charging calculation = The sum of total length of Ø 3/8 inch (9.52 mm) liquid pipe(m) x 1.94oz (55g) + the sum of total length of Ø 1/4 inch (6.35 mm) liquid pipe(m) x 0.71oz (20g)

Ex) a(Ø 3/8 inch (9.52 mm))=131.23ft (40m), b+c+d(Ø 3/8 inch (9.52 mm))=49.21ft (15m),

e+f+g(Ø 1/4 inch (6.35 mm))=49.21ft (15m)

The amount of additional refrigerant = 180.45ft (55m) x 1.94oz (55g) + 49.21ft (15m) x 0.71oz (20g) = 117.29oz (3325g)

Capacity Index (MBH)	5	6	7	9	12	15	18	20	24	27	28	30	32	36	42	48	54	60	72	76	96	144	
1-Way cassette (VOWD***S6-5P)	0.31 (0.14)		0.31 (0.14)	0.51 (0.23)	0.51 (0.23)	0.64 (0.29)	0.64 (0.29)		0.64 (0.29)														
Mini 4-Way cassette (V22D***S6-5P)	0.57 (0.26)		0.57 (0.26)	0.57 (0.26)	0.73 (0.33)		0.73 (0.33)	0.73 (0.33)															
4-Way cassette (V33D***S6-5P)		1.46 (0.66)		1.46 (0.66)	1.46 (0.66)		1.46 (0.66)		1.46 (0.66)			1.74 (0.79)	1.74 (0.79)	1.74 (0.79)									
360 cassette (V36D***S6-5P)				0.90 (0.41)	0.90 (0.41)		0.90 (0.41)		0.90 (0.41)			1.37 (0.62)	1.37 (0.62)	1.37 (0.62)									
LSP duct (VLOD***S6-5P)			0.62 (0.28)	0.62 (0.28)	0.62 (0.28)		0.62 (0.28)		0.62 (0.28)														
MSP duct (VMDD***S6-5P)		0.90 (0.41)	0.90 (0.41)	0.90 (0.41)	0.90 (0.41)		0.90 (0.41)	1.34 (0.61)															
HSP duct (VHID***S6-5P)									1.34 (0.61)	1.34 (0.61)		1.34 (0.61)		1.68 (0.76)	1.68 (0.76)	1.68 (0.76)					2.34 (1.06)	2.34 (1.06)	
OAP duct (VOSD***S6-5P)																						2.34 (1.06)	2.34 (1.06)
Floor Standing (VSCD***S6-5P) (VSED***S6-5P)		0.24 (0.11)		0.44 (0.20)	0.44 (0.20)		0.64 (0.29)		0.64 (0.29)														
Ceiling (VUCD***S6-5P)							0.95 (0.43)		0.95 (0.43)					0.95 (0.43)	1.90 (0.86)								
MPAHU(V-AHU) (VWCD***S6-5P)					0.66 (0.30)		1.00 (0.45)		1.00 (0.45)			1.65 (0.75)	1.74 (0.79)	2.34 (1.06)	2.51 (1.14)	3.35 (1.52)	3.35 (1.52)						
Wall mounted (VWMD***S6-5P)	0.46 (0.21)		0.46 (0.21)	0.64 (0.29)	0.64 (0.29)	0.95 (0.43)	0.95 (0.43)		0.95 (0.43)		0.95 (0.43)	1.34 (0.61)											
Hydro unit HE ^{Note1)} (VHED***S6-5P)														1.19 (0.54)	1.19 (0.54)							1.39 (0.63)	2.38 (1.08)
Hydro unit HT ^{Note1)} (VHTD***S6-5P)															1.19 (0.54)				1.19 (0.54)				

Ex) When the indoor unit VOWD007S6-5P and V33D030S6-5P are combined

Additional refrigerant charging = 4.94oz (140g) + 27.87oz (790g) = 32.80oz (930g)

2. The total amount of additional refrigerant charging = the amount of refrigerant charging for pipe + the amount of refrigerant for each indoor unit.

Ex) The amount of additional refrigerant charging = 117.29oz (3325g) + 23.99oz (680g) = 141.27oz (4005g)

Note1) In case the capacity conjunction of the Hydro Unit HT/HE exceeds 50 % among the total indoor unit, please don't put the additional refrigerant.

Refrigerant pipe installation

Connecting the drain hose to the outdoor unit

When using the air conditioner in the heating mode, ice may accumulate. During de-icing (defrost operation), the condensed water must be drained off safely. Consequently, you must install a drain hose on the outdoor unit, following the instructions below.

- ▶ Leave space of more than 1.97inch (50mm) between the bottom of the outdoor unit and the ground for installation of the drain hose, as shown in figure.
- ▶ Insert the drain plug into the hole on the underside of the outdoor unit.
- ▶ Connect the drain hose to the drain plug.
- ▶ Ensure that the drained water runs off correctly and safely.

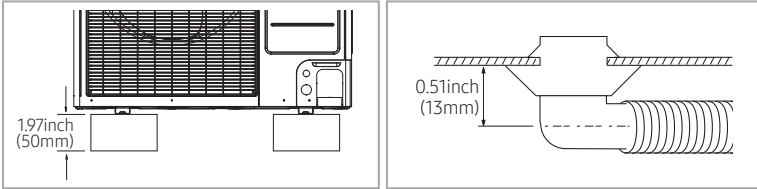

- ▶ Be sure to plug the rest of drain holes not connected with drain plugs using drain caps.

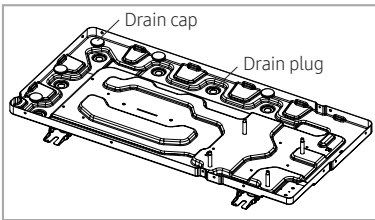

Insulating refrigerant pipe or Y-joint

- ▶ You must check if there is a gas leak before completing all the installation process. After you check that the gas does not leak, you must insulate the pipe and hose.
- ▶ Use EPDM insulation which meets the following condition.

Item	Unit	Standard
Density	g/cm ³	0.048~0.096
Dimension change route by heat	%	-5 or less
Water absorption rate	g/cm ³	0.005 or less
Thermal conductivity	kcal/m·h·°C	0.032 or less
Moisture transpiration factor	ng/(m ² ·s·Pa)	15 or less
Moisture transpiration grade	g/(m ² ·24h)	15 or less
Formaldehyde dispersion	mg/L	-
Oxygen rate	%	25 or more

Selecting the insulation of refrigerant pipe

- ▶ Insulate the gas pipe and liquid pipe by referring to the thickness of insulator for each pipe size.
- ▶ The standard condition is 86°F(30°C), with humidity less than 85%. In the conditions of high humidity, use one grade thicker.

Pipe	Pipe size [inch(mm)]	Insulation(Cooling, Heating)		Remarks
		Standard [86°F(30°C), 85%]	High humidity [86°F(30°C), 85% or more]	
		EPDM, NBR		
Liquid pipe	Ø1/4(6.35)~Ø3/8(9.52)	9t	9t	Heat resisting temperature is more than 248°F(120°C)
	Ø1/2(12.70)~Ø2(50.80)	13t	13t	
Gas pipe	Ø1/4(6.35)	13t	19t	
	Ø3/8(9.52)	19t	25t	
	Ø1/2(12.70)			
	Ø5/8(15.88)			
	Ø3/4(19.05)			
Ø7/8(22.22)				

Insulating refrigerant pipe

- ▶ You must insulate refrigerant pipe, Y-joint, header joint, and pipe connection area.
- ▶ If you insulate the pipes, the condensed water does not fall from the pipes.
- ▶ Check if there are any insulation cracks on the bent pipe.

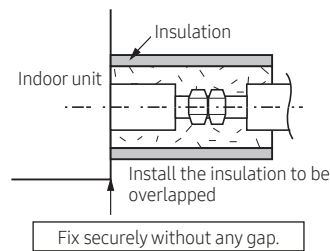
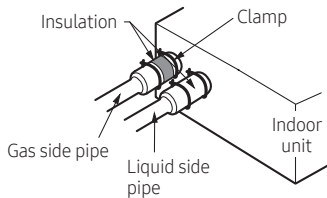

Refrigerant pipe installation

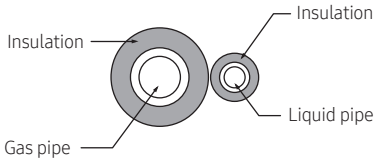
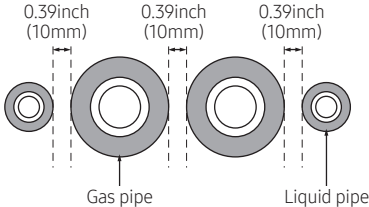
Pipe insulation	Pipe insulation after insulating EEV kit
<ul style="list-style-type: none"> The insulation of the gas and liquid pipes can be in contact with each other but they should not press excessively against each other. When contacting the gas side and liquid side pipe, use thicker insulation. 	<ul style="list-style-type: none"> When installing the gas side and liquid side pipes, leave 3/8"(10mm) of space. When contacting the gas side and liquid side pipe, use thicker insulation.
	



- Install the insulation not to get wider and use adhesive on the connection part of it to prevent moisture entering.
- Bind the refrigerant pipe with insulation tape if it is exposed to outside sunlight. (When binding the pipe with finishing tape, be careful not to reduce the thickness of the insulation.)
- Install the refrigerant pipe respecting that the insulation does not get thinner on the bent part or hanger of pipe.
- When the thickness of insulation is reduced, supplement the reduced thickness with additional insulation.

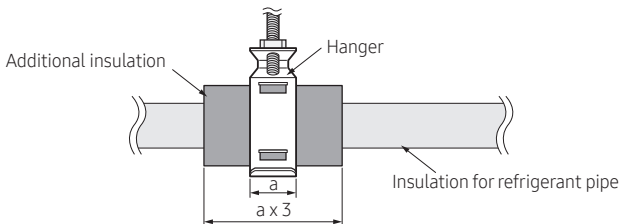

Insulating the header joint

- ▶ Fasten the header joint using a cable tie and cover the connected part.
- ▶ Insulate the header joint and the brazing part and wrap the connected part with an adhesive insulation tape to prevent dew formation.

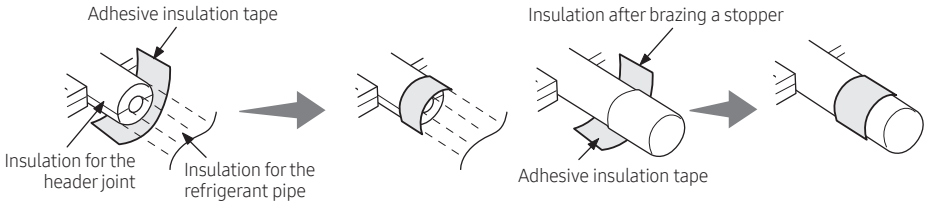
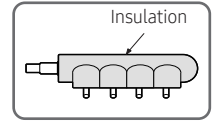

- ▶ Fix the header joint with a hanger after insulating it.

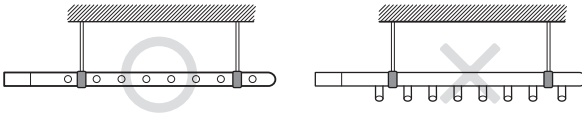

Insulating the Y-joint, liquid & gas side connecting pipe

- ▶ Attach the insulation provided with the Y-joint to the insulation purchased privately without a gap. Wrap the connected part with insulation (Purchased privately) of a thickness of at least 3/8"(10mm).
- ▶ Use insulation that should be able to handle an interior temperature of over 248°F(120°C). Wrap the Y- joint with insulation of a thickness of at least 3/8"(10mm).

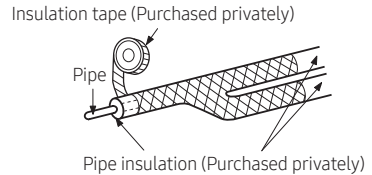
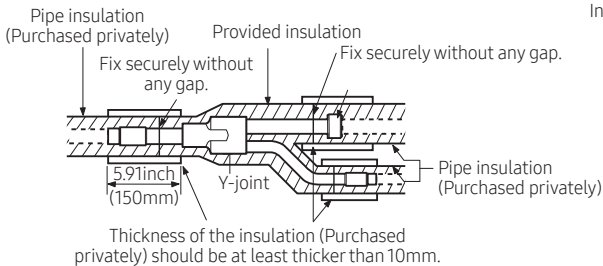

- ※ Attach the adhesive insulation tape to the pipe as shown in the picture after insulating the pipe.

Wiring work

- ▶ Wiring work should be performed in accordance with related laws such as ‘Technical specification on electric installation’, ‘Wiring regulations’ or ‘Installation manual’.
- ▶ Copper cable should be used for wiring work and all the wires or parts should be rated products.
- ▶ Wiring work should be performed by a company certified by an electric power company.
- ▶ Refer to the circuit diagram attached to the outdoor unit for detailed wiring work.
- ▶ Wiring work should be performed after disconnecting main circuit breaker and Y-joint switch.
- ▶ You must perform grounding work .
(Grounding resistance value should be less than 100Ω.)
When ELCB is installed, protective grounding resistance value can be applied.
(When the ELCB is 100mA, 0.1sec, protective grounding resistance value should be less than 250Ω at a place where electric danger is high and should be less than 500Ω at other places.)
- ▶ Electric wiring circuit diagram displays outline only.
- ▶ Do not connect a heater to an outdoor unit and do not install a duct which you arbitrarily remodeled.
 - Failure to do so may result in reduced capacity of an air conditioner, electric shock, and fire.
- ▶ Do not connect the grounding wire to that of gas pipe, water pipe, lightning rod, or telephone.
 - Gas pipe: If the gas leaks, explosion or ignition may occur.
 - Water pipe: If rigid vinyl pipe is used, grounding effect will not work.
 - Grounding wire and lightning rod of telephone: The electric potential of grounding wire may rise abnormally in the falling of a thunderbolt.
- ▶ The ELB for ground-fault protection only should be combined with MCCB or fuse equipped load breaker switch. In this case, you should use the one that has at least the same or more capacity as fuse capacity or the rated current of MCCB.
- ▶ Use the wires that comply with regulated specification and firmly connect to the terminal board. Then tighten it with the screws provided so that the terminal board cannot be moved by external force. (The connecting cable and the grounding terminal should be locally procured). When wiring, the connection cable shouldn't be too tight.
- ▶ Apply silicon at the end of CD pipe so that rainwater does not enter.

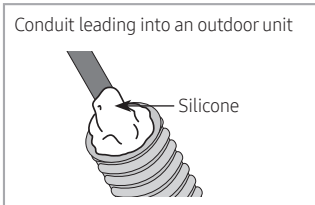

Overall System Configuration

Connection of the power cable (1 Ø 2 wires)

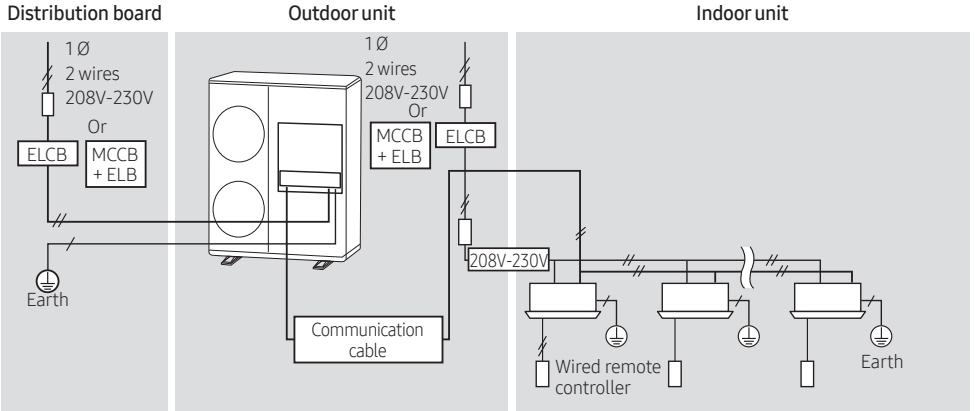

Connection of the power cable (1 Ø 2 wires using EEV kit)

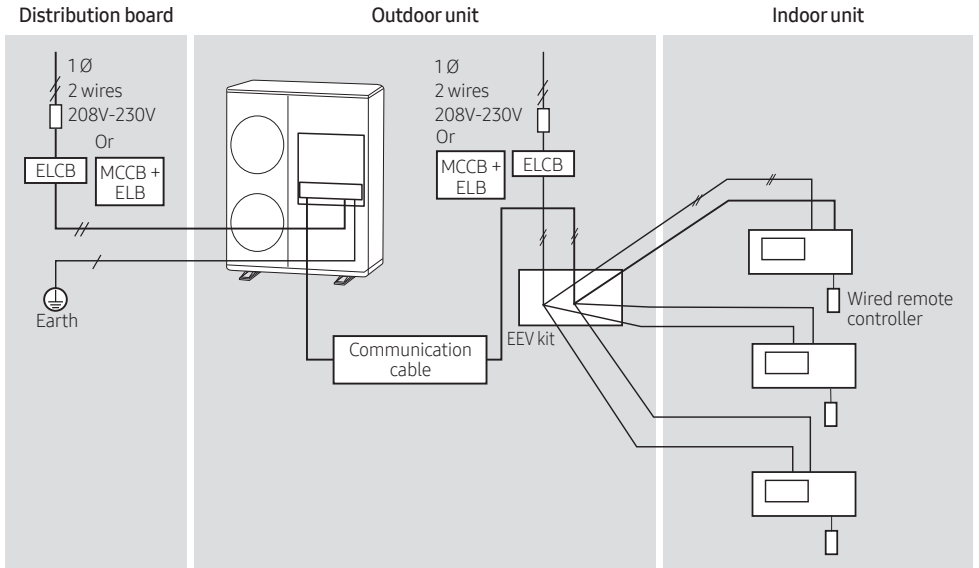

Wiring work



- You must install an earth leakage breaker.
 - ELCB(Earth Leakage Circuit Breaker)
 - MCCB(Molded Case Circuit Breaker)
 - ELB(Earth Leakage fuse breaker)
- Manufacturers are not responsible for fire caused by not installing ELCB or MCCB.
- Install the cabinet panel near the outdoor unit for service convenience and emergency operation switch off.
- You must install a circuit breaker that can prevent excess current and shut off the electric leakage on the outdoor unit.

Tightening power terminal

- ▶ Connect the cables to the terminal board using the compressed ring terminal.
- ▶ Use rated cables only.
- ▶ Connect the cables with driver and wrench that can apply the rated torque to the screws.
- ▶ Make sure that appropriate tightening torque is applied for cable connection. If the terminal is loose, arc heat may occur and cause fire and if the terminal is connected too firmly, terminal may get damaged.

Tightening torque			
M4	12.0~18.0 kgf•cm	1.2~1.8 N•m	Communication : F1, F2 3 phase AC power: 1(L), 2(N), L, N, L1(R), L2(S), L3(T), N
M5	20.0~30.0 kgf•cm	2.0~3.0 N•m	1 phase AC power : 1(L), 2(N), L, N

Selecting compressed ring terminal

- ▶ Select a compressed ring terminal of a connecting power cable based on a nominal dimensions for cable.
- ▶ Cover a compressed ring terminal and a connector part of the power cable and then connect it.

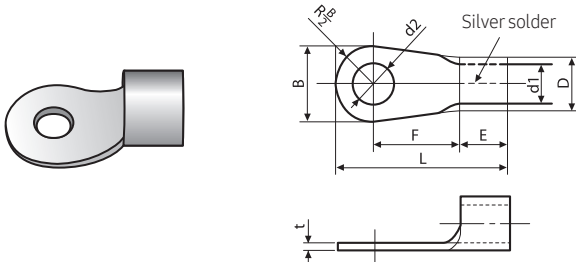

Nominal dimensions for cable [mm ² (inch ²)]		4/6 (0.006/0.009)		10 (0.01)	16 (0.02)	25 (0.03)		35 (0.05)		50 (0.07)	70 (0.10)
Nominal dimensions for screw [mm(inch)]		4 (3/8)	8 (3/16)	8 (3/16)	8 (3/16)	8 (3/16)	8 (3/16)	8 (3/16)	8 (3/16)	8 (3/16)	8 (3/16)
B	Standard dimension [mm(inch)]	9.5 (3/8)	15 (9/16)	15 (9/16)	16 (10/16)	12 (1/2)	16.5 (10/16)	16 (10/16)	22 (7/8)	22 (7/8)	24 (1)
	Allowance [mm(inch)]	±0.2 (±0.007)		±0.2 (±0.007)	±0.2 (±0.007)	±0.3 (±0.011)		±0.3 (±0.011)		±0.3 (±0.011)	±0.4 (±0.015)
D	Standard dimension [mm(inch)]	5.6 (1/4)		7.1 (1/4)	9 (3/8)	11.5 (7/16)		13.3 (1/2)		13.5 (1/2)	17.5 (1/2)
	Allowance [mm(inch)]	+0.3 (+0.011) -0.2 (-0.007)		+0.3 (+0.011) -0.2 (-0.007)	+0.3 (+0.011) -0.2 (-0.007)	+0.5 (+0.019) -0.2 (-0.007)		+0.5 (+0.019) -0.2 (-0.007)		+0.5 (+0.019) -0.2 (-0.007)	+0.5 (+0.019) -0.4 (-0.015)
d1	Standard dimension [mm(inch)]	3.4 (1/8)		4.5 (3/16)	5.8 (1/4)	7.7 (5/16)		9.4 (3/8)		11.4 (7/16)	13.3 (1/2)
	Allowance [mm(inch)]	±0.2 (±0.007)		±0.2 (±0.007)	±0.2 (±0.007)	±0.2 (±0.007)		±0.2 (±0.007)		±0.3 (±0.011)	±0.4 (±0.015)
E	Min. [mm(inch)]	6 (1/4)		7.9 (5/16)	9.5 (5/16)	11 (3/8)		12.5 (1/2)		17.5 (11/16)	18.5 (3/4)
F	Min. [mm(inch)]	5 (3/16)	9 (3/8)	9 (3/8)	13 (1/2)	15 (5/8)	13 (1/2)	13 (1/2)		14 (9/16)	20 (3/4)
L	Max. [mm(inch)]	20 (3/4)	28.5 (1-1/8)	30 (1-3/16)	33 (1-5/16)	34 (1-3/8)		38 (1-1/2)	43 (1-11/16)	50 (1.96)	51 (2.00)
d2	Standard dimension [mm(inch)]	4.3 (3/16)	8.4 (1-3/16)	8.4 (1-3/16)	8.4 (1-3/16)	8.4 (1-3/16)		8.4 (1-3/16)		8.4 (1-3/16)	8.4 (1-3/16)
	Allowance [mm(inch)]	+ 0.2 (+0.007) 0 (0)	+0.4 (+0.015) 0 (0)	+0.4 (+0.015) 0 (0)	+0.4 (+0.015) 0 (0)	+0.4 (+0.015) 0 (0)		+0.4 (+0.015) 0 (0)		+0.4 (+0.015) 0 (0)	+0.4 (+0.015) 0 (0)
t	Min. [mm(inch)]	0.9 (0.03)		1.15 (0.04)	1.45 (0.05)	1.7 (0.06)		1.8 (0.07)		1.8 (0.07)	2.0 (0.078)

Wiring work

Installing grounding wire

- ▶ Grounding must be done by a qualified installer for your safety.
- ▶ Use the grounding wire by referring to the specification of the electric cable of the outdoor unit.

Grounding the power cable

- ▶ The standard of grounding may vary according to the rated voltage and installation place of the air conditioner.
- ▶ Ground the power cable according to the following.

Installation place Power condition	High humidity	Average humidity	Low humidity
Voltage of lower than 150V		Perform the grounding work 3. <small>Note 1)</small>	Perform the grounding work 3 if possible for your safety. <small>Note 2)</small>
Voltage of higher than 150V		Must perform the grounding work 3. <small>Note 1)</small> (In case of installing circuit breaker as well)	



1. Grounding work 3

- Grounding must be done by your installation specialist.
- Check if the grounding resistance is lower than 100Ω. When installing a circuit breaker that can cut the electric circuit within 0.5 second in case of a short circuit, the allowable grounding resistance should be 30~500Ω.

2. Grounding at dry place

- The grounding resistance is should be lower than 100Ω. (It should not be higher than 250Ω)
- Use the rated grounding wire by referring to the specification of the electric cable of the outdoor unit.

Performing the grounding work

- ▶ Use the grounding wire by referring to the specification of the electric cable for the outdoor unit.

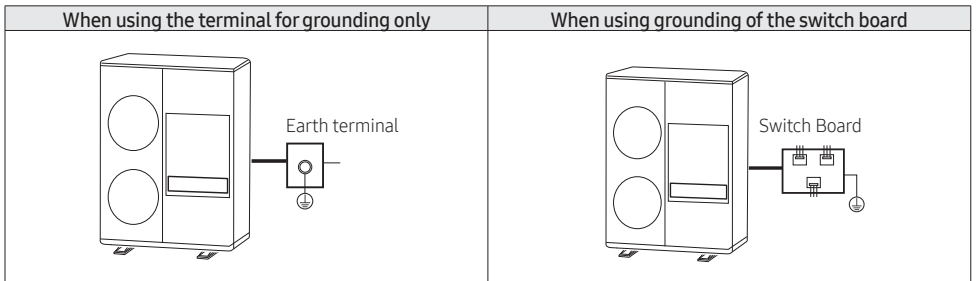

Grounding work

If the power distribution circuit does not have a grounding or the grounding does not comply with specifications, a ground rod must be installed.

The corresponding accessories are not supplied with the air conditioner.

1. Select a grounding rod that complies with the specifications given in the illustration.

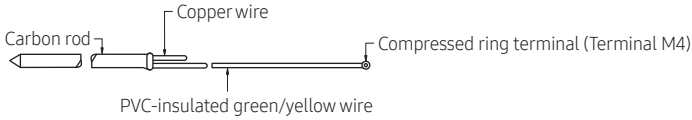

2. Select a proper place for the grounding rod installation.
 - In damp hard soil rather than loose sandy or gravel soil that has a higher grounding resistance.
 - Away from underground structures or facilities, such as gas pipes, water pipes, telephone lines and underground cables.
 - At least two meters away from lightning(as in a storm) conductor.

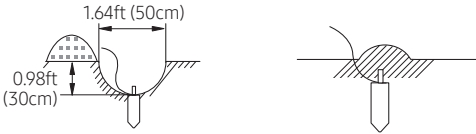

- The grounding wire for the telephone line cannot be used to ground the air conditioner.

3. Install a green/yellow coloured grounding wire :
 - Refer to the 'Wiring work' for the specification of grounding wire.
 - When the grounding wire is too short, extend the grounding wire but bind the connection part with insulation tape. (Do not bury the connection).
 - Secure the grounding wire in position with staples.



- When the grounding rod is installed in a place where many people pass by, you must fix it firmly.

4. Carefully check the installation, by measuring the grounding resistance with a ground resistance tester.
 - If the resistance is above required level, drive the grounding rod deeper into the ground or increase the number of grounding rods.
5. Connect the grounding wire to the electrical component box inside of the outdoor unit.

Charging refrigerant

- ▶ Measure the quantity of the refrigerant according to the length of the liquid side pipe. Add quantity of the refrigerant using a scale.

Precautions on adding R-32 refrigerant

In addition to the conventional charging procedure, the following requirements shall be kept.



- Make sure that contamination by other refrigerants does not occur for charging.
- To minimize the amount of refrigerant, keep the hoses and lines as short as possible.
- The cylinders shall be kept upright.
- Make sure that the refrigeration system is earthed before charging.
- Label the system with the final system charge with indelible ink.
- Extreme care is required not to overcharge the system.
- If the system must be evacuated for any reason, before recharging system tightness must be checked with nitrogen.
- After charging, check for leakage before commissioning.
- Be sure to check for leakage before leaving the work area.



Please fill in the following with indelible ink on the refrigerant charge label supplied with this product and on this manual.

- ① the factory refrigerant charge of the product,
- ② the additional refrigerant amount charged in the field and
- ① + ② the total refrigerant charge. on the refrigerant charge label supplied with the product.

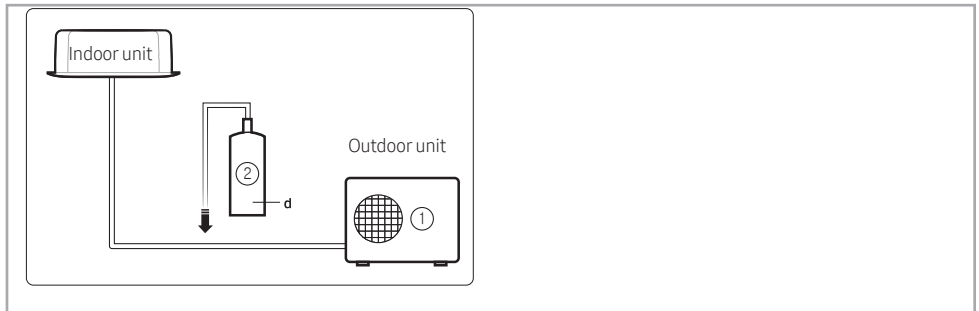

- a Factory refrigerant charge of the product: see unit nameplate
- b Additional refrigerant amount charged in the field (Refer to the above information for the quantity of refrigerant replenishment.)
- c Total refrigerant charge
- d Refrigerant cylinder and manifold for charging



- Make sure that the total refrigerant charge does not exceed (A), the maximum refrigerant charge, which is calculated in the following formula: Maximum refrigerant charge (A) = factory refrigerant charge (B) + maximum additional refrigerant charge due to piping extension (C)
- The table below shows the refrigerant charge limits for each product.

Charging refrigerant

- ▶ Open the manifold gauge valve connected to the liquid side service valve and add the liquid refrigerant.
- ▶ If you cannot add the whole quantity of the refrigerant while the outdoor unit is stopped, open the gas side and liquid side service valve. Then, add remaining refrigerant by pressing the refrigerant adding button of the outdoor PCB.

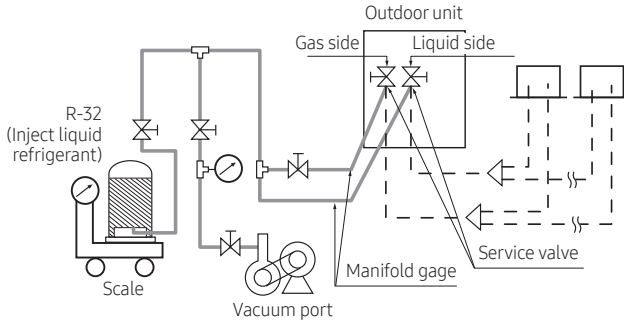

- Open the gas side and liquid side service valve completely after charging the refrigerant. (If you operate the air conditioner with the service valve closed, the important parts may be damaged.)
- Put on safety equipment when charging refrigerant.
- Do not charge the refrigerant when you adjust or control other product such as indoor units or EEV kits.
- When the ambient temperature is low in winter time, do not heat the refrigerant container to speed up the charging process. There is risk of explosion.
- Beware for possibility of refrigerant leakage when you connect the manifold gauge to the charging port for heating.
- Close the valve of the refrigerant container immediately after charging the refrigerant. If not, there might be a change in entire amount of refrigerant.

Basic segment display

Step	Display content	Display			
		SEG 1	SEG 2	SEG 3	SEG 4
At initial power input	Checking segment display	SEG 1	SEG 2	SEG 3	SEG 4
		"8"	"8"	"8"	"8"
While setting communication between indoor and outdoor unit (Addressing)	Number of connected indoor units	SEG 1	SEG 2	SEG 3	SEG 4
		"A"	"d"	Number of communicated units ※ Refer to "View Mode" for communication address	
After communication setting (usual occasion)	MSB, Indoor unit address	SEG 1	SEG 2	SEG 3	SEG 4
		I/U: "A" MSB: "C"	I/U: "0" MSB: "1"	Reception address (in decimal number)	

※ I/U : Indoor unit, MSB : HR Changer & MSB

Setting outdoor unit option switch and key function

Setting outdoor unit option switches

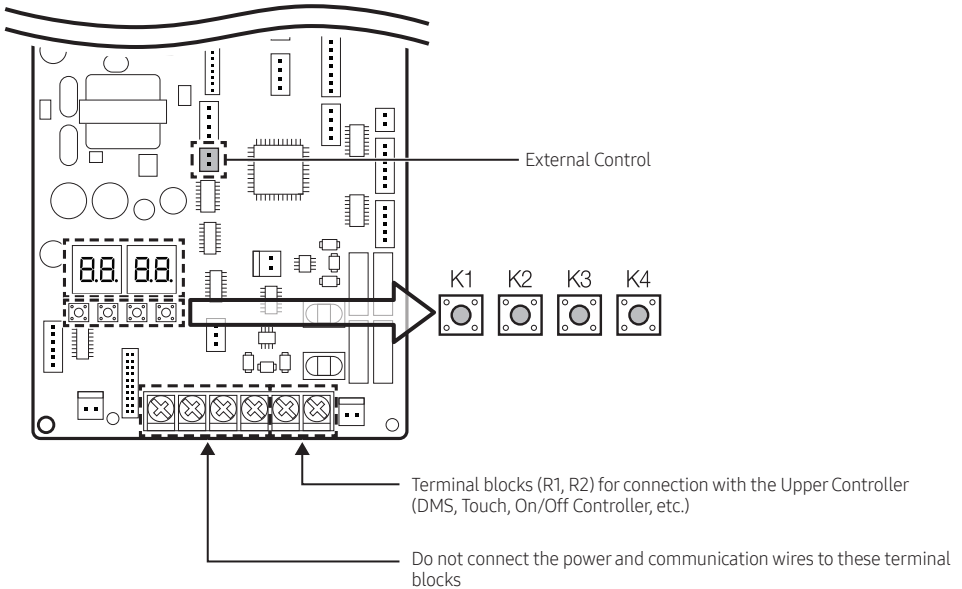

Setting outdoor unit option switch and key function

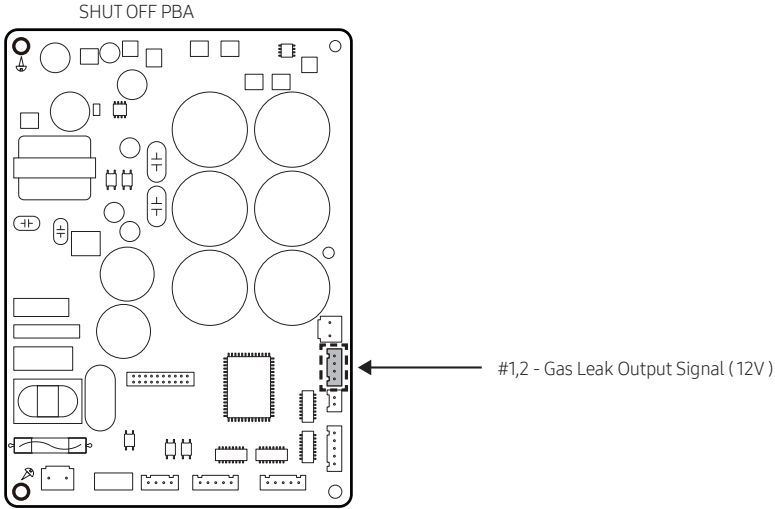

► Setting outdoor install option

Step	Button	Display	Description	Note
Quantity of indoor units				
		7d nd	Setting required	
Step1	Press (K1+K2) for 2 seconds	7d 00	Ready to set	-
Step2	K2 x n times	7d X0	Tens digit (0 ~ 6)	Ex) 03 : 3 units 10 : 10 units
	K4 x n times	7d 0X	Ones digit (0 ~ 9)	
* K4 : Press for 2 seconds - automatic detection of indoor units' quantity				
Step3	If it is heat recovery model, go to step 4. Otherwise, press K2 button for 2 seconds to save & exit. (system will be reset)			
Step4	K2 : long	Rd 00	Save	Restart
* Press K1 for 2 seconds to exit without save regardless of setting step.				

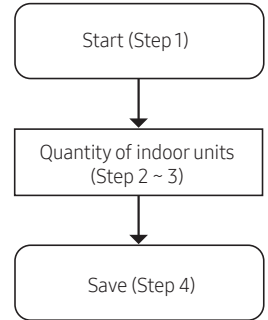

Setting outdoor unit option switch and key function

Installing and setting the option with tact switch and explanation of the functions

Setting the option

1. Press and hold K2 to enter the option setting. (Only available when the operation is stopped)
 - If you enter the option setting, display will show the following. (If you have set the 'Emergency operation for compressor malfunction', 1 or 2 will be displayed on SEG 4.)

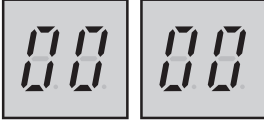

- SEG 1 and SEG 2 will display the number for selected option.
 - SEG 3 and SEG 4 will display the number for set value of the selected option.
2. If you have entered option setting, you can shortly press the K1 switch to adjust the value of the SEG 1, SEG 2 and select the desired option.

Example)

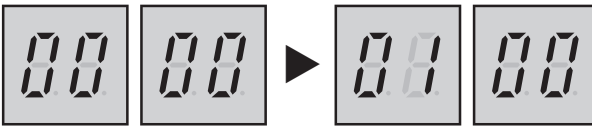

3. If you have selected desired option, you can shortly press the K2 switch to adjust the value of the SEG 3, SEG 4 and change the function for the selected option.

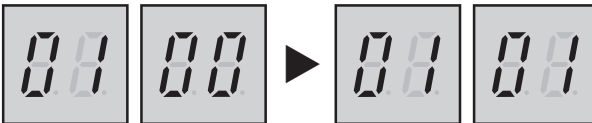

4. After selecting the function for options, press and hold the K2 switch for 2 seconds. Edited value of the option will be saved when entire segments blinks and tracking mode begins.



• Edited option will not be saved if you do not the option setting as explained in above instruction.

- ※ While you are setting the option, you may press and hold the K1 button to reset the value to previous setting.
- ※ If you want to restore the setting to factory default, press and hold the K4 button while you are in the option setting mode.
 - If you press and hold the K4 button, setting will be restored to factory default but it doesn't mean that restored setting is saved. Press and hold the K2 button. When the segments shows that tracking mode is in progress, setting will be saved.

Optional item	Input unit	SEG1	SEG2	SEG3	SEG4	Function of the option	Remarks
Unused option	Main	0	0	0	0	Unused option	Unused option by this model
Cooling capacity correction	Main	0	1	0	0	44.6-48.2 (7-9)	Targeted evaporation temperature [°F (°C)]. (When low temperature value is set, discharged air temperature of the indoor unit will decrease)
				0	1	41-44.6 (5-7) (Factory default)	
				0	2	48.2-51.8 (9-11)	
				0	3	50-53.6 (10-12)	
				0	4	51.8-55.4 (11-13)	
				0	5	53.6-57.2 (12-14)	
				0	6	55.4-59 (13-15)	
Capacity correction for heating	Main	0	2	0	0	3.0 (Factory default)	Targeted high pressure [MPa]. (When low pressure value is set, discharged air temperature of the indoor unit will decrease)
				0	1	2.5	
				0	2	2.6	
				0	3	2.7	
				0	4	2.8	
				0	5	2.9	
				0	6	3.1	
				0	7	3.2	
Current restriction rate	Main	0	3	0	0	100% (Factory default)	When restriction option is set, cooling and heating performance may decrease. ※ If the rate is set to 1 and 1, there is no current limit, so current usage exceeding 100% is possible. Current usage may be limited due to protection control.
				0	1	95%	
				0	2	90%	
				0	3	85%	
				0	4	80%	
				0	5	75%	
				0	6	70%	
				0	7	65%	
				0	8	60%	
				0	9	55%	
				1	0	50%	
Oil collection interval	Main	0	4	0	0	Factory default	
				0	1	Shorten the interval by 1/2	
Temperature to trigger defrost operation	Main	0	5	0	0	Factory default	The defrost option shortens the starting time of the defrost operation
				0	1	Apply setting when the product is being installed in humid area such as near river or lake	
Fan speed correction for outdoor unit	Main	0	6	0	0	Disabled (Factory default)	Increase the outdoor unit's fan speed to maximum value
				0	1	Increase fan speed	

Setting outdoor unit option switch and key function

Optional item	Input unit	SEG1	SEG2	SEG3	SEG4	Function of the option	Remarks
Silent mode for night-time	Main	0	7	0	0	Disabled (Factory default)	Enables the silent mode for night-time in cooling mode. (It operates automatically depending on the temperature.) However, if the external contact interface module(VSTAT10P-1) is used, entering the silent mode is available with contact signal in cooling and heating mode.
				0	1	LEVEL 1 / Auto	
				0	2	LEVEL 2 / Auto	
				0	3	LEVEL 3 / Auto	
				0	4	LEVEL 1 / External contact	
				0	5	LEVEL 2 / External contact	
				0	6	LEVEL 3 / External contact	
High-head condition setting	Main	0	8	0	0	Disabled (Factory default)	When outdoor unit is located 131.23~262.47ft (40~80m) above the indoor unit
				0	1	Level 1 of height difference type 1 (indoor unit is lower than outdoor unit)	
				0	2	Not applicable	
				0	3	Height difference type 2 (outdoor unit is lower than indoor unit)	
Long-pipng condition setting (Setting is unnecessary if high-head condition is set)	Main	0	9	0	0	Disabled (Factory default)	When equivalent length of farthest indoor unit from the outdoor unit is over 328.08ft (100m)
				0	1	LEVEL 1	
				0	2	Not applicable	
Energy saving setting	Main	1	0	0	0	Disabled (Factory default)	Energy saving mode triggers when the room temperature reaches desired temperature while operating in heating mode.
				0	1	Energy saving mode	
				0	2	Rapid cooling	
Unused option	Main	1	1~2	0	0	Unused option	Unused option by this model
Channel address	Main	1	3	A	U	Automatic setting (factory default)	Address for classifying the product from upper level controller (DMS,Touch controller,etc.)
				00 ~ 15		Manual setting for channel 0 – 15	
Snow accumulation prevention control	Main	1	4	0	0	Enabled	During snow accumulation, the fan may spin even when the unit is not in operation
				0	1	Disabled (Factory default)	
Unused option	Main	1	5~7	0	0	Unused option	Unused option by this model
Max. capacity restriction	Main	1	8	0	0	Enabled (Factory default)	Restrict excessive capacity increase when operating indoor units with small capacity
				0	1	Disabled	
Gas leak pump down	Main	1	9	0	0	Disabled (Factory default)	If the gas leak occurred it should be entered in the pump down operation.
				0	1	Enabled	
Unused option	Main	2	0~2	0	0	Unused option	Unused option by this model

Optional item	Input unit	SEG1	SEG2	SEG3	SEG4	Function of the option	Remarks
Base Heater	Main	2	3	0	0	Disabled (Factory default)	Set when Base Heater is installed.
				0	1	Enabled	
Unused option	Main	2	4	0	0	Unused option	Unused option by this model
Aux Heater's interworking control for cycle heating (cooling priority control)	Main	2	5	0	0	Not applied (Factory default)	When using the Aux Heater, set the delay time for switching from cooling to heating.
				0	1	Switching delay to heating (30 mins.)	
				0	2	Switching delay to heating (15 mins.)	
				0	3	Switching delay to heating (10 mins.)	
				0	4	Switching delay to heating (5 mins.)	
0	5	No switching delay					
Auto Change Over	Main	2	6	0	0	Not applied (Factory default)	With Thermo off for all running indoor units, change the operation mode.
				0	1	Applied	
Unused option	Main	2	7-8	0	0	Unused option	Unused option by this model
View mode Unit Option	Main	2	9	0	0	°C & MPa (Factory default)	Converts the temperature, pressure units in the view mode (K4 switch)
				0	1	°F & psi	
Emergency heat	Main	3	0	0	0	Disabled (Factory default)	While configured, in case of the system errors, emergency heating operation is possible using an external heater.
				0	1	Enabled	

※ In case the following errors occur, emergency heating operation is not possible.

- Indoor unit room temperature sensor and fan error (E121, E154, E155)
- Refrigerant leak sensor error (E116, E695, E696, E697, E698, E700, E797)



- After installing the product, be sure to perform leak tests on the piping connections. After pumping down refrigerant to inspect or relocate the outdoor unit, be sure to stop the compressor and then remove the connected pipes.
 - Do not operate the compressor while a valve is open due to refrigerant leakage from a pipe or an unconnected or incorrectly connected pipe. Failure to do so may cause air to flow into the compressor and too a high pressure to develop inside the refrigerant circuit, leading to an explosion or product malfunction.

Setting outdoor unit option switch and key function

Setting key operation and checking the view mode with tact switch

K1 Control	KEY operation	Display on segment
Press and hold 1 time	Auto trial operation	"K" "K" "BLANK" "BLANK"
K1(Number of press)	KEY operation	Display on segment
1 time	Refrigerant charging in Heating mode ^(Note 1)	"K" "1" "BLANK" "BLANK"
2 times	Trial operation in Heating mode ^(Note 1)	"K" "2" "BLANK" "BLANK"
3 times	Pump out in Heating mode ^(Note 1)	"K" "3" "BLANK" "1"
4 times	Vacuuming	"K" "4" "BLANK" "1"
5 times	Inverter Fault Detection	"K" "5" "1" "1"
6 times	End Key operation	—
K2(Number of press)	KEY operation	Display on segment
1 time	Refrigerant charging in Cooling mode	"K" "5" "BLANK" "BLANK"
2 times	Trial operation in Cooling mode	"K" "6" "BLANK" "BLANK"
3 times	Pump down in Cooling mode	"K" "7" "BLANK" "BLANK"
4 times	Automatic setting of operation mode (Cooling/Heating) for trial operation	"K" "8" "BLANK" "BLANK"
5 times	Checking the amount of refrigerant	"K" "9" "X" "X" (Display of last two digits may differ depending on the progress)
6 times	Discharge mode of DC link voltage	"K" "A" "BLANK" "BLANK"
7 times	Forced defrost operation	"K" "B" "BLANK" "BLANK"
8 times	Forced oil collection	"K" "C" "BLANK" "BLANK"
9 times	Inverter compressor check	"K" "D" "BLANK" "BLANK"
10 times	H/R : Auto pipe pairing H/P : Unused	"K" "H" "X" "X" (Display of last two digits may differ depending on the progress)
11 times	Emergency check standby mode	"K" "L" "BLANK" "BLANK"
12 times	End Key operation	—

- ※ Even when the outdoor unit power is off, it is dangerous when you come in contact with inverter PCB since it is charged with high DC voltage.
- ※ When replacing/repairing the PCB, cut-off the power and wait until the DC voltage is discharged before replacing/repairing them. (Wait for more than 15 minutes to allow it to discharge naturally.)
- ※ When there were error, 'Discharge mode of DC link voltage' may not have been effective. Especially if error E464 has been occurred, power element might be damaged by fire and therefore, do not use the 'Discharge mode of DC link voltage'.
- ※ During "Discharge mode of DC link voltage", voltage of INV will be displayed.

K3(Number of press)	KEY operation	Display on segment
1 time	Initialize (Reset) setting	Same as initial state

K4 (Number of press)	KEY operation	Display on segment	
		SEG 1	SEG2, 3, 4
1 time	Outdoor unit Capacity (HP)	1	6HP → 0, 0, 6
2 times	Order frequency of compressor	2	120 Hz → 1, 2, 0
3 times	High pressure	3	1.52 MPa → 1, 5, 2 / 220 psi → 2, 2, 0
4 times	Low pressure	4	0.43 MPa → 0, 4, 3 / 62 psi → 0, 6, 2
5 times	Discharge temperature of compressor	5	87 °C → 0, 8, 7 / 189 °F → 1, 8, 9
6 times	IPM temperature of compressor	6	87 °C → 0, 8, 7 / 189 °F → 1, 8, 9
7 times	CT sensor value of compressor	7	2 A → 0, 2, 0
8 times	Suction temperature	8	-42 °C → -, 4, 2 / -44 °F → -, 4, 4
9 times	COND OUT temperature	9	-42 °C → -, 4, 2 / -44 °F → -, 4, 4
10 times	Liquid pipe temperature	A	87 °C → 0, 8, 7 / 189 °F → 1, 8, 9
11 times	TOP temperature of compressor	B	87 °C → 0, 8, 7 / 189 °F → 1, 8, 9
12 times	Outdoor temperature	C	-42 °C → -, 4, 2 / -44 °F → -, 4, 4
13 times	EVI inlet temperature	D	-42 °C → -, 4, 2 / -44 °F → -, 4, 4
14 times	EVI outlet temperature	E	-42 °C → -, 4, 2 / -44 °F → -, 4, 4
15 times	Main EEV step	F	2000 steps → 2, 0, 0
16 times	EVI EEV step	G	300 steps → 3, 0, 0
17 times	Fan step	H	13 steps → 0, 1, 3
18 times	Current frequency of compressor	I	120 Hz → 1,2,0
19 times	Master indoor unit address (Master indoor unit can be selected by wired remote-controller)	J	Master indoor unit not selected → BLANK, N, D If indoor unit No.1 is selected as the master unit → 0, 0, 1
20 times	MSB Bypass EEV Step	K	300 steps → 3, 0, 0
21 times	Refrigerant leak detection sensor operational duration	L	1000 days → 100
22 times	End Key operation	-	-

K4 (Press and hold for 2 seconds to enter the setting) → K4 press (Number of press)	Displayed content	Display on segment		
		Page 1	Page 2	
1 time	Main version	MAIN	Ver. (ex) 1412	
2 times	Inverter version	INV1	Ver. (ex) 1412	
3 times	EEP version	EEP	Ver. (ex) 1412	
4 times	SHUT OFF version	SHOF	Ver. (ex) 1412	
5 times	Assigned address of the units	AUTO	SEG 1,2	SEG 3,4
			Indoor unit: "A", "0" HR Changer/MSB Unit : "C", "1"	Address (ex) 07)
6 times	Manually assigned address of the units	MANU	SEG 1,2	SEG 3,4
			Indoor unit: "A", "0"	Address (ex) 15)
Press and hold (for 2 sec.)	Key operation ends	-	-	

Inspection and check operation



Precautions before check operation

- When the outdoor temperature is low, turn on the main power 3 hours before beginning the operation.
 - If you start the operation immediately after turning on the main power, it may cause serious damage to the part within the product.
- Do not touch the refrigerant pipe during or right after the operation.
 - Refrigerant pipe may be hot or cold during or right after the operation depending on the status of the refrigerant which flows through the refrigerant pipe, compressor and other parts of the refrigerant cycle. If you touch the refrigerant during or right after the operation, you may get burns or frostbite.
- Do not operate the product with its panel or protection nets off.
 - There is risk of personal injury from the parts that rotates, heated or with the high voltage.
- Do not turn off the main power immediately after stopping the operation.
 - Wait for at least 5 minutes before turning off the main power. If not, water leakage or other problems may occur.
 - Be ware that when system is powered off, the leak detection function, and remote control alarm function does not work anymore. So try to avoid power down status as much as possible.
- Connect all the indoor units and the power supply for the outdoor unit and run auto or manual address setting. Run auto or manual address setting after changing the indoor unit PCB.

Inspection before check operation

1. Check the power cable and communication cable of the indoor and outdoor unit.
 2. Supply power to the outdoor unit 3 hours before check operation to preheat the compressor.
 3. Before supplying the power, use a voltmeter and phase tester to check the voltage and the phase.
 - R,S,T terminal: check the 380 V ~ 415 V between wires (R-S, S-T, T-R) / 220V~240V between wires (L-N).
 4. When the power is supplied, outdoor unit will execute tracking to check the indoor unit connection and other options.
 5. Write down the installation report on the service history report paper attached on the front part of the control box.
 6. Guaranteed range of check operation
- For correct judgment, you must perform check operation in below indoor/outdoor temperature condition.

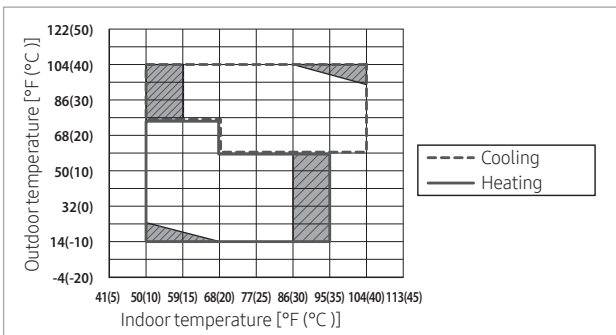

- Check operation selects and operates cooling/heating mode automatically.
- In the temperature range marked with slashed pattern, system protection control may trigger during operation. (It may be hard to judge the check operation correctly due to protection control operation.)
- When the temperature is outside of guaranteed range, accuracy of judgment on check operation may decrease near boarder line area. Inspection and check operation.

Check operation

1. Use KEY MODE to run check operation.
 - When the check operation is not completed, UP (unprepared) will appear on the LED after the communication check and restrict compressor from operating. (UP Mode will be cleared automatically when check operation is completed.)
 - Check operation may proceed from 30 minutes maximum 50 minutes depending on the operation status.
 - During check operation, noise can be generated due to valve inspection. (Check the product if abnormal noise occurs continuously.)
2. When error occurs during check operation, check the error code and take appropriate measures.
 - Refer to service manual if you need inspection or when other errors occur.
3. When check operation ends, use S-NET pro 2 to issue a result report.
 - Refer to service manual for further actions if you have any items with "inspection required" sign on the result report.
 - After taking appropriate measure for the items with "inspection needed" sign, run the check operation again.
4. Check the following items by running (cooling/heating) trial operation.
 - Check if cooling/heating operation performs normally.
 - Individual indoor unit control: Check for air flow direction and fan speed.
 - Check for abnormal operation noise from the indoor and outdoor unit.
 - Check for proper draining from the indoor unit during cooling operation.
 - Use S-NET pro 2 to check the detail operation status.
5. Explain to the user how to use the air conditioner according to the user's manual.
6. Hand over the installation manual to the customer so they can keep it with them.

Checklist after finishing installation

- ▶ Before supplying power, measure the power terminal (L, N) and outdoor unit grounding using insulation-resistance tester.
 - The measured value should be above 30MΩ.



- You must not measure the communication terminal since the communication circuit may get damaged.
- Check the short circuit using a circuit tester.

Installation	Outdoor unit	<ul style="list-style-type: none"> • Have you secured air discharge profile at the bottom of service cover? • Have you checked the external surface and the inside of the outdoor unit? • Is there any possibility of short circuit due to the heat of an outdoor unit? • Is the place well-ventilated and ensures space for service? • Is the outdoor unit fixed securely?
	Indoor unit	<ul style="list-style-type: none"> • Have you checked the external surface and the inside of the indoor unit? • Is the place well-ventilated and has enough space been allowed for service? • Have you checked if the center of the indoor unit is ensured and it is installed horizontally?
Refrigerant pipe work		<ul style="list-style-type: none"> • Have you selected correct pipes? • Are the liquid and gas valve open? • Is the total number of connecting indoor units within the allowable range? • Are the length and the height difference between the refrigerant pipes within the allowable range? • Is the refrigerant Y-joint properly installed? • Has the connection of liquid and gas pipes been correctly performed? • Have you chosen correct insulation for pipes and have you insulated them correctly? • Is the pipe or connection part properly insulated? • Is the quantity of the additional refrigerant correctly weighed in? (You must record the amount of additional refrigerant charging on the service record paper placed outside the outdoor unit.)

<p>Installing the drain pipe</p>	<ul style="list-style-type: none"> • Have you checked whether the drain pipes of the indoor unit and outdoor unit are connected together? • Have you completed the drain test? • Is the drain pipe properly insulated?
<p>Wiring work</p>	<ul style="list-style-type: none"> • Are the power cable and communication cable tightened firmly on the terminal board within the range of rated tightening torque? • Have you performed the earthing work 3 to the outdoor unit? • Is 2-core cable used for the communication cable? • Is the length of the wire is in the limited range? • Is the wiring route correct?
<p>Setting ADDRESS</p>	<ul style="list-style-type: none"> • Are the ADDRESSES of the indoor and outdoor units properly set? • Are the ADDRESSES of the remote controller properly set? (When using multiple remote controllers)
<p>Option</p>	<ul style="list-style-type: none"> • Have you checked whether the vibration-resistance frame is correctly installed if there is a possible vibration of the outdoor unit.

Automatic refrigerant amount detection function (Checking the amount of refrigerant)

This function detects amount of refrigerant in the system through refrigerant amount detection operation.

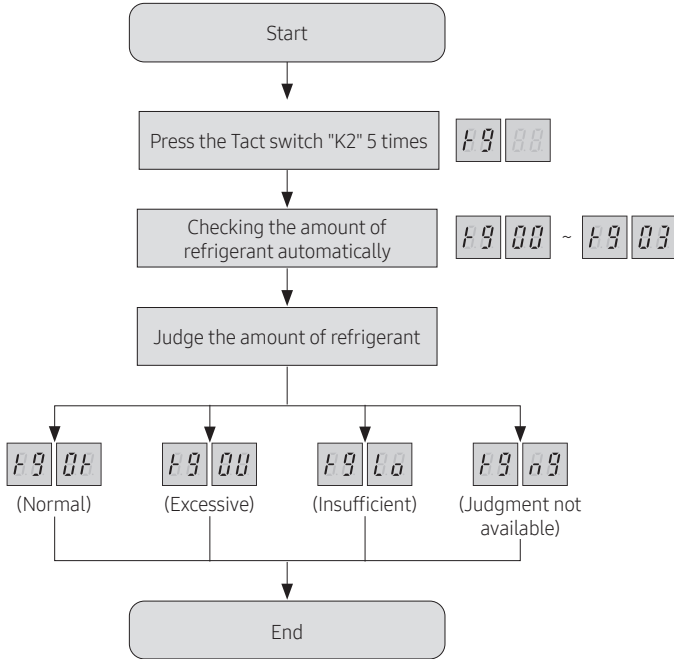

- If the temperature is out of the guaranteed range below, exact result will not be obtained.
 - Indoor: 68~89.6°F (20~32°C)
 - Outdoor: 41~109.4°F (5~43°C)
- If the operation cycle is not stable, the operation of refrigerant amount check may be forcibly finished.
- Accuracy of the result may decrease if the product has not been operated for a long period of time or Heat mode has been operated before running the function of refrigerant amount check. Therefore, use the function of refrigerant amount check after operating the product in Cool mode for at least 30 minutes.
- Product may trigger system protection operation depending on the installation environment. In this case, the result of refrigerant amount check may not be accurate.

Actions to take for the check result

- Excessive amount of refrigerant
 - Discharge 10% of total amount of refrigerant and restart the refrigerant amount check.
- Insufficient amount of refrigerant
 - Add 10% of the total amount of refrigerant and restart the refrigerant amount check.
- Judgment not available
 - Check if the function of refrigerant amount check is executed within the guaranteed temperature range. Run trial operation to check if there are other problems on the system.

Trial operation

- ▶ Check the power supply between the outdoor unit and the cabinet panel.
 - 1 phase power supply : L, N
 - 3 phase power supply: R, S, T, N
- ▶ Check the indoor unit.
 - Check whether you have connected the power and communication cables correctly. (The communication cables between an indoor unit and outdoor unit are F1, F2.)
 - Check the thermistor sensor, drain pump/hose, and display are connected correctly.
- ▶ Check with Key mode or S-NET pro 2.
 - At first, operate all the indoor units with Key mode and operate the indoor units individually with S-Net Pro.
 - In the beginning of operation, check the compressor operation sound. If there is a boom sound, stop the trial operation.
- ▶ Check the operation status of indoor and outdoor unit.
 - Check whether the cooling operation is done correctly.
 - Check the individual indoor unit control, wind velocity, and wind flow direction.
 - Check whether you can hear abnormal sound from indoor unit and outdoor unit.
 - Check whether the drainage is done correctly in cooling.
 - Check S-net Pro for detailed operation.
- ▶ Explain to the user the usage of the air conditioner by referring to the users manual.



- Turn on the outdoor unit 3 hours before the test operation to preheat the compressor.

