

# UNIT INFORMATION

# LDT

100148

6.5 / 7.5 / 8.5 / 10 / 12.5

## Service Literature

### LDT DUAL FUEL SERIES WITH R-454B

The LDT commercial combination heat pump and gas heat unit is available in 6.5 / 7.5 / 8.5 / 10 / 12.5 ton cooling capacities. The LDT078, 092, 102, 120 and 152 refrigerant systems utilize two compressors, two reversing valves, two accumulators (152 only), and other parts common to a heat pump. Units are available in 130,000, 180,000 or 240,000Btuh (38.1, 52.7 or 70.3 kW) heating inputs. Gas heat sections are designed with stainless steel tube heat exchangers.

LDT078-152 units are equipped with variable-volume, direct drive blowers. These units will provide supply air at lower speeds when cooling demand is low and increase to higher speeds when cooling demand is high. Refer to Supply Air Start-Up sections.

LDT units are designed to accept any of several different energy management thermostat control systems with minimum field wiring.

If the unit must be lifted for service, rig unit by attaching four cables to the holes located in the unit base rail (two holes at each corner). Refer to the installation instructions for the proper rigging technique.

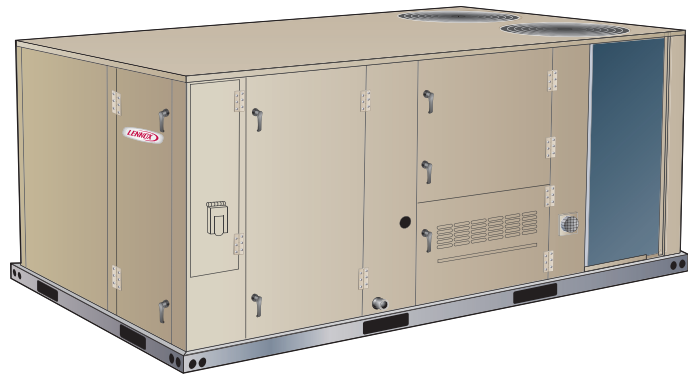

False ceilings or drop ceiling may be used as a return air plenum only if the unit being installed has a Refrigerant Detection System installed.

All maintenance staff and others working in the local area shall be instructed on the nature of work being carried out with work in confined spaces being avoided.

Ensure that the area is in the open or that it is adequately ventilated before breaking into the system or conducting any hot work. A degree of ventilation shall continue during the period that the work is carried out. The ventilation should safely disperse any released refrigerant and preferably expel it externally into the atmosphere.

#### Table of Contents

|   |         |
|---|---------|
| Options / Accessories . . . . .             | Page 3  |
| Specifications . . . . .                    | Page 6  |
| Blower Tables . . . . .                     | Page 9  |
| Electrical Data . . . . .                   | Page 12 |
| Parts Arrangement . . . . .                 | Page 16 |
| I-Unit Components . . . . .                 | Page 17 |
| II-Placement and Installation . . . . .     | Page 31 |
| III-Start Up . . . . .                      | Page 31 |
| IV-System Service Checks . . . . .          | Page 34 |
| V-Maintenance . . . . .                     | Page 38 |
| VI-Accessories . . . . .                    | Page 39 |
| VII-Wiring and Operation Sequence . . . . . | Page 45 |
| VIII-Decommissioning . . . . .              | Page 57 |

### **⚠ WARNING**

Do not use means to accelerate the defrosting process or to clean, other than those recommended by the manufacturer.

The appliance shall be stored in a room without continuously operating ignition sources (for example: open flames, an operating gas appliance, or an operating electric heater).

Do not pierce or burn.

Be aware that refrigerants may not contain an odor.

### **⚠ WARNING**

If this appliance is conditioning a space with an area smaller than TA min or stored in a space with an area smaller than A min as defined by this instruction, then that space must be without continuously operating open flames (e.g. an operating gas appliance) or other potential ignition sources (e.g. an operating electric heater or similar hot surface). A flame-producing device may be installed in the same space if the device is provided with an effective flame arrest system.

### **⚠ WARNING**

Auxiliary devices which may be potential ignition sources shall not be installed in the duct work. Examples of potential ignition sources are hot surfaces with a temperature exceeding 700°C and electric switching components.

## **⚠ WARNING**

To prevent serious injury or death:

- 1- Lock-out/tag-out before performing maintenance.
- 2- If system power is required (e.g., smoke detector maintenance), disable power to blower, remove fan belt where applicable, and ensure all controllers and thermostats are set to the "OFF" position before performing maintenance.
- 3- Always keep hands, hair, clothing, jewelry, tools, etc., away from moving parts.

## **⚠ CAUTION**

Any service personnel installing, decommissioning, or performing maintenance on the unit must be properly trained with A2L refrigerants.

## **⚠ WARNING**



Electric shock hazard. Can cause injury or death. Before attempting to perform any service or maintenance, turn the electrical power to unit OFF at disconnect switch(es). Unit may have multiple power supplies.

## **⚠ WARNING**

Improper installation, adjustment, alteration, service or maintenance can cause property damage, personal injury or loss of life. Installation and service must be performed by a licensed professional HVAC installer or equivalent, service agency, or the gas supplier.

## **⚠ CAUTION**

As with any mechanical equipment, contact with sharp sheet metal edges can result in personal injury. Take care while handling this equipment and wear gloves and protective clothing.

## **⚠ IMPORTANT**

The Clean Air Act of 1990 bans the intentional venting of refrigerant (CFC's and HCFC's) as of July 1, 1992. Approved methods of recovery, recycling or reclaiming must be followed. Fines and/or incarceration may be levied for non-compliance.

## **⚠ WARNING**

Only manufacturer approved auxiliary devices are permitted to be installed in this unit.

## **⚠ CAUTION**

Leak Detection System installed. Unit must be powered except for service.

## **⚠ CAUTION**

Servicing shall be performed only as recommended by the manufacturer.

## **⚠ WARNING**

- This appliance must be installed in accordance with local and national wiring regulations.
- If the appliance is not fitted with an option for full disconnection from power, a means of disconnection must be incorporated in the fixed wiring in accordance with national and local wiring regulations.

## **⚠ WARNING**

Ducts connected to an appliance shall not contain a potential ignition source.

## **⚠ IMPORTANT**

Pipe work, including piping material, pipe routing, and installation shall include protection from physical damage in operation and service, and be in compliance with national and local codes and standards, such as ASHRAE 15, ASHRAE 15.2, IAPMO Uniform Mechanical Code, ICC International Mechanical Code, or CSA B52. All field joints shall be accessible for inspection prior to being covered or enclosed.

## **⚠ IMPORTANT**

Refrigerant sensors for refrigerant detection systems shall only be replaced with sensors specified by the appliance manufacture.

## **⚠ CAUTION**

This unit is equipped with electrically powered safety measures. To be effective, the unit must be electrically powered at all times after installation, other than when servicing.

## OPTIONS / ACCESSORIES

| Item Description  | Catalog Number                       | Unit Model No |     |     |     |     |    |
|---|--------------------------------------|---------------|-----|-----|-----|-----|----|
|   |                                      | 078           | 092 | 102 | 120 | 152 |    |
| <b>COOLING SYSTEM</b>   |                                      |               |     |     |     |     |    |
| Condensate Drain Trap   | PVC                                  | <b>22H54</b>  | X   | X   | X   | X   | X  |
|   | Copper                               | <b>76W27</b>  | X   | X   | X   | X   | X  |
| Drain Pan Overflow Switch   |                                      | <b>21Z07</b>  | OX  | OX  | OX  | OX  | OX |
| <b>GAS HEATING SYSTEM</b>   |                                      |               |     |     |     |     |    |
| Bottom Gas Piping Kit   |                                      | <b>54W95</b>  | X   | X   | X   | X   | X  |
| Combustion Air Intake Extensions                                      |                                      | <b>19W51</b>  | X   | X   | X   | X   | X  |
| Gas Heat Input  | 130,000 Btuh                         | Factory       | O   | O   | O   | O   | O  |
|   | 180,000 Btuh                         | Factory       | O   | O   | O   | O   | O  |
|   | 240,000 Btuh                         | Factory       |     | O   | O   | O   | O  |
| Low Temperature Vestibule Heater                                      | 208/230V-3ph                         | <b>22A51</b>  | X   | X   | X   | X   | X  |
|   | 460V                                 | <b>22A55</b>  | X   | X   | X   | X   | X  |
|   | 575V                                 | <b>13X65</b>  | X   | X   | X   | X   | X  |
| LPG/Propane Conversion Kits   | Standard Heat                        | <b>14N22</b>  | X   | X   | X   | X   | X  |
|   | Medium Heat                          | <b>14N23</b>  | X   | X   | X   | X   | X  |
|   | High Heat                            | <b>14N25</b>  | X   | X   | X   | X   | X  |
| Vertical Vent Extension   |                                      | <b>42W16</b>  | X   | X   | X   | X   | X  |
| <b>BLOWER - SUPPLY AIR</b>  |                                      |               |     |     |     |     |    |
| Blower Option   | DirectPlus™ Blower System with MSAV® | Factory       | O   | O   | O   | O   | O  |
| <b>CABINET</b>  |                                      |               |     |     |     |     |    |
| Combination Coil/Hail Guards  |                                      | <b>24C86</b>  | OX  | OX  | OX  | OX  |    |
|   |                                      | <b>37A56</b>  |     |     |     |     | OX |
| Corrosion Protection  |                                      | Factory       | O   | O   | O   | O   | O  |
| Horizontal Discharge Kit  |                                      | <b>51W25</b>  | X   | X   | X   | X   | X  |
| Return Air Adaptor Plate (for LC/LG/LH and TC/TG/TH unit replacement) |                                      | <b>54W96</b>  | OX  | OX  | OX  | OX  | OX |
| <b>CONTROLS</b>   |                                      |               |     |     |     |     |    |
| Commercial Controls   | CPC Einstein Integration             | Factory       | O   | O   | O   | O   | O  |
|   | LonTalk® Module                      | <b>54W27</b>  | OX  | OX  | OX  | OX  | OX |
|   | Novar® LSE                           | Factory       | O   | O   | O   | O   | O  |
| Dirty Filter Switch   |                                      | <b>53W67</b>  | OX  | OX  | OX  | OX  | OX |
| Fresh Air Tempering   |                                      | <b>21Z08</b>  | OX  | OX  | OX  | OX  | OX |
| Smoke Detector - Supply or Return (Power board and one sensor)        |                                      | <b>31A68</b>  | OX  | OX  | OX  | OX  | OX |
| Smoke Detector - Supply and Return (Power board and two sensors)      |                                      | <b>31A69</b>  | OX  | OX  | OX  | OX  | OX |

NOTE - Catalog numbers shown are for ordering field installed accessories.

OX = Configure To Order (Factory Installed) or Field Installed.

O = Configure To Order (Factory Installed).

X = Field Installed.

## OPTIONS / ACCESSORIES

| Item Description   | Catalog Number  | Unit Model No |     |     |     |     |    |
|--|---|---------------|-----|-----|-----|-----|----|
|  |   | 078           | 092 | 102 | 120 | 152 |    |
| <b>INDOOR AIR QUALITY</b>  |   |               |     |     |     |     |    |
| <b>Air Filters</b>   |   |               |     |     |     |     |    |
| Healthy Climate® High Efficiency Air Filters<br>20 x 25 x 2 in. (Order 4 per unit)           | MERV 8  | <b>50W61</b>  | OX  | OX  | OX  | OX  | OX |
|  | MERV 13   | <b>52W41</b>  | OX  | OX  | OX  | OX  | OX |
|  | MERV 16   | <b>21U41</b>  | X   | X   | X   | X   | X  |
| Replacement Media Filter With Metal Mesh Frame (includes non-pleated filter media)           |   | <b>Y3063</b>  | X   | X   | X   | X   | X  |
| <b>Indoor Air Quality (CO<sub>2</sub>) Sensors</b>   |   |               |     |     |     |     |    |
| Sensor - Wall-mount, off-white plastic cover with LCD display                                |   | <b>77N39</b>  | X   | X   | X   | X   | X  |
| Sensor - Wall-mount, off-white plastic cover, no display                                     |   | <b>23V86</b>  | X   | X   | X   | X   | X  |
| Sensor - Black plastic case, LCD display, rated for plenum mounting                          |   | <b>87N52</b>  | X   | X   | X   | X   | X  |
| Sensor - Black plastic case, no display, rated for plenum mounting                           |   | <b>23V87</b>  | X   | X   | X   | X   | X  |
| CO <sub>2</sub> Sensor Duct Mounting Kit - for downflow applications                         |   | <b>23Y47</b>  | X   | X   | X   | X   | X  |
| Aspiration Box - for duct mounting non-plenum rated CO <sub>2</sub> sensors (77N39)          |   | <b>90N43</b>  | X   | X   | X   | X   | X  |
| <b>Needlepoint Bipolar Ionization (NPBI)</b>   |   |               |     |     |     |     |    |
| Needlepoint Bipolar Ionization (NPBI) Kit  |   | <b>22U15</b>  | X   | X   | X   | X   | X  |
| <b>UVC Germicidal Lamps</b>  |   |               |     |     |     |     |    |
| <sup>1</sup> Healthy Climate® UVC Light Kit (110/230v-1ph)                                   |   | <b>21A93</b>  | X   | X   | X   | X   | X  |
| Step-Down Transformers   | 460V primary, 230V secondary  | <b>10H20</b>  | X   | X   | X   | X   | X  |
|  | 575V primary, 230V secondary  | <b>10H21</b>  | X   | X   | X   | X   | X  |
| <b>ELECTRICAL</b>  |   |               |     |     |     |     |    |
| Voltage 60 Hz  | 208/230V - 3 phase  | Factory       | O   | O   | O   | O   | O  |
|  | 460V - 3 phase  | Factory       | O   | O   | O   | O   | O  |
|  | 575V - 3 phase  | Factory       | O   | O   | O   | O   | O  |
| Disconnect Switch  | 80 amp  | <b>54W56</b>  | OX  | OX  | OX  | OX  | OX |
| <sup>2</sup> Short-Circuit Current Rating (SCCR) of 100kA (includes Phase/Voltage Detection) |   | Factory       | O   | O   | O   | O   | O  |
| GFI Service Outlets  | 15 amp non-powered, field-wired (208/230V, 460V only)               | <b>74M70</b>  | OX  | OX  | OX  | OX  | OX |
|  | 15 amp factory-wired and powered (208/230V, 460V)                   | Factory       | O   | O   | O   | O   | O  |
|  | <sup>3</sup> 20 amp non-powered, field-wired (208/230V, 460V, 575V) | <b>67E01</b>  | X   | X   | X   | X   | X  |
|  | <sup>3</sup> 20 amp non-powered, field-wired (575V only)            | Factory       | O   | O   | O   | O   | O  |
| Weatherproof Cover for GFI   |   | <b>10C89</b>  | X   | X   | X   | X   | X  |

<sup>1</sup> Lamps operate on 110-230V single-phase power supply. Step-down transformer may be ordered separately for 460V and 575V units. Alternately, 110V power supply may be used to directly power the UVC ballast(s).

<sup>2</sup> Disconnect Switch not available with higher SCCR option.

<sup>3</sup> Canada requires a minimum 20 amp circuit. Select 20 amp, non-powered, field wired GFI.

NOTE - Catalog numbers shown are for ordering field installed accessories.

OX = Configure To Order (Factory Installed) or Field Installed.

O = Configure To Order (Factory Installed).

X = Field Installed.

## OPTIONS / ACCESSORIES

| Item Description   | Catalog Number                       | Unit Model No |     |     |     |     |
|--|--------------------------------------|---------------|-----|-----|-----|-----|
|  |                                      | 078           | 092 | 102 | 120 | 152 |
| <b>ECONOMIZER</b>  |                                      |               |     |     |     |     |
| <b>High Performance Economizer (Approved for California Title 24 Building Standards / AMCA Class 1A Certified)</b>                                   |                                      |               |     |     |     |     |
| High Performance Economizer (Downflow or Horizontal)   | <b>20U80</b>                         | OX            | OX  | OX  | OX  | OX  |
| Includes Economizer Dampers with Outdoor Air Hood and Barometric Relief Dampers with Exhaust Hood  |                                      |               |     |     |     |     |
| Downflow Applications - Use furnished Outdoor Air Hood and Barometric Relief Dampers with Exhaust Hood   |                                      |               |     |     |     |     |
| Horizontal Applications - Use furnished Outdoor Air Hood and Barometric Relief Dampers with Exhaust Hood - Order Horizontal Discharge Kit separately |                                      |               |     |     |     |     |
| Horizontal Applications (reduced height) - Order Horizontal Low Profile Barometric Relief  |                                      |               |     |     |     |     |
| Dampers with Exhaust Hood and Horizontal Discharge Kit (51W25) separately  |                                      |               |     |     |     |     |
| <b>Horizontal Low Profile Barometric Relief Dampers</b>  |                                      |               |     |     |     |     |
| Horizontal Low Profile Barometric Relief Dampers (Exhaust hood furnished)  | <b>53K04</b>                         | X             | X   | X   | X   | X   |
| <b>Economizer Controls</b>   |                                      |               |     |     |     |     |
| Differential Enthalpy (Not for Title 24)   | Order 2 <b>21Z09</b>                 | OX            | OX  | OX  | OX  | OX  |
| Sensible Control   | Sensor is Furnished <b>Factory</b>   | O             | O   | O   | O   | O   |
| Single Enthalpy (Not for Title 24)   | <b>21Z09</b>                         | OX            | OX  | OX  | OX  | OX  |
| Building Pressure Control  | <b>13J77</b>                         | X             | X   | X   | X   | X   |
| Outdoor Air CFM Control  | <b>13J76</b>                         | X             | X   | X   | X   | X   |
| Global Control   | Sensor Field Provided <b>Factory</b> | O             | O   | O   | O   | O   |
| <b>OUTDOOR AIR</b>   |                                      |               |     |     |     |     |
| <b>Outdoor Air Dampers With Outdoor Air Hood</b>   |                                      |               |     |     |     |     |
| Motorized  | <b>14G28</b>                         | OX            | OX  | OX  | OX  | OX  |
| Manual   | <b>14G29</b>                         | X             | X   | X   | X   | X   |
| <b>POWER EXHAUST</b>   |                                      |               |     |     |     |     |
| Standard Static  | 208/230V-3ph <b>53W44</b>            | OX            | OX  | OX  | OX  | OX  |
|  | 460V-3ph <b>53W45</b>                | OX            | OX  | OX  | OX  | OX  |
|  | 575V-3ph <b>53W46</b>                | OX            | OX  | OX  | OX  | OX  |
| <b>ROOF CURBS</b>  |                                      |               |     |     |     |     |
| <b>Hybrid Roof Curbs, Downflow</b>   |                                      |               |     |     |     |     |
| 8 in. height   | <b>11F54</b>                         | X             | X   | X   | X   | X   |
| 14 in. height  | <b>11F55</b>                         | X             | X   | X   | X   | X   |
| 18 in. height  | <b>11F56</b>                         | X             | X   | X   | X   | X   |
| 24 in. height  | <b>11F57</b>                         | X             | X   | X   | X   | X   |
| <b>Adjustable Pitch Curb</b>   |                                      |               |     |     |     |     |
| 14 in. height  | <b>54W50</b>                         | X             | X   | X   | X   | X   |
| <b>CEILING DIFFUSERS</b>   |                                      |               |     |     |     |     |
| Step-Down - Order one  | RTD11-95S <b>13K61</b>               | X             | X   |     |     |     |
|  | RTD11-135S <b>13K62</b>              |               |     | X   | X   |     |
|  | RTD11-185S <b>13K63</b>              |               |     |     |     | X   |
| Flush - Order one  | FD11-95S <b>13K56</b>                | X             | X   |     |     |     |
|  | FD11-135S <b>13K57</b>               |               |     | X   | X   |     |
|  | FD11-185S <b>13K58</b>               |               |     |     |     | X   |

NOTE - Catalog numbers shown are for ordering field installed accessories.  
OX = Configure To Order (Factory Installed) or Field Installed.  
O = Configure To Order (Factory Installed).  
X = Field Installed.

| SPECIFICATIONS                   |  | 6.5 TON   7.5 TON   8.5 TON                          |   |   |                |
|----------------------------------|--|--|---|---|----------------|
| Model                            |  | LDT078H5E  | LDT092H5E                               | LDT102H5E                               |                |
| Nominal Tonnage                  |  | 6.5 Ton  | 7.5 Ton                                 | 8.5 Ton                                 |                |
| Efficiency Type                  |  | High   | High                                    | High                                    |                |
| Blower Type                      |  | DirectPlus™ ECM Direct Drive with MSAV®              | DirectPlus™ ECM Direct Drive with MSAV® | DirectPlus™ ECM Direct Drive with MSAV® |                |
| Cooling Performance              | Gross Cooling Capacity - Btuh                | 79,000   | 92,000                                  | 100,000                                 |                |
|                                  | <sup>1</sup> Net Cooling Capacity - Btuh     | 78,000   | 90,000                                  | 98,000                                  |                |
|                                  | AHRI Rated Air Flow - cfm                    | 2400   | 2800                                    | 2800                                    |                |
|                                  | Total Unit Power - kW                        | 6.4  | 7.6                                     | 8.3                                     |                |
|                                  | <sup>1</sup> EER (Btuh/Watt)                 | 12.2   | 11.9                                    | 11.9                                    |                |
|                                  | <sup>1</sup> IEER (Btuh/Watt)                | 16.5   | 16.0                                    | 15.5                                    |                |
|                                  | Total Unit Power (kW)                        | 6.5  | 7.4                                     | 8.4                                     |                |
| Heating Performance              | <sup>1</sup> Total High Heat Capacity (Btuh) | 73,000   | 86,000                                  | 96,000                                  |                |
|                                  | <sup>1</sup> AHRI Rated Airflow (cfm)        | 2600   | 3200                                    | 3400                                    |                |
|                                  | <sup>1</sup> COP                             | 3.5  | 3.5                                     | 3.5                                     |                |
|                                  | Total Unit Power (kW)                        | 6.1  | 7.3                                     | 8.0                                     |                |
|                                  | <sup>1</sup> Total Low Heat Capacity (Btuh)  | 40,000   | 46,000                                  | 53,000                                  |                |
|                                  | <sup>1</sup> COP                             | 2.25   | 2.25                                    | 2.25                                    |                |
|                                  | Total Unit Power (kW)                        | 5.2  | 6.7                                     | 7.3                                     |                |
| Sound Rating Number              | dBA  | 88   | 88                                      | 88                                      |                |
| Refrigerant Charge               | Refrigerant Type                             |  | R-454B                                  | R-454B                                  | R-454B         |
|                                  | w/o Reheat Option                            | Circuit 1  | 11 lbs. 8 oz.                           | 11 lbs. 0 oz.                           | 10 lbs. 12 oz. |
|                                  |  | Circuit 2  | 11 lbs. 0 oz.                           | 11 lbs. 4 oz.                           | 11 lbs. 4 oz.  |
| Gas Heat Available - See page 37 |  | Standard (2 stage), Medium (2 Stage), High (2 Stage) |   |   |                |
| Compressor Type (number)         |  | Two-Stage Scroll (1)<br>Single-Stage Scroll (1)      |   |   |                |
| Outdoor Coil                     | Net face area - ft. <sup>2</sup> (total)     | 25.9   | 25.9                                    | 25.9                                    |                |
|                                  | Tube diameter - in.                          | 3/8  | 3/8                                     | 3/8                                     |                |
|                                  | Rows   | 3  | 3                                       | 3                                       |                |
|                                  | Fins - inch                                  | 20   | 20                                      | 20                                      |                |
| Outdoor Coil Fans                | Motor HP (number and type)                   | 1/3 (2 ECM)  | 1/3 (2 ECM)                             | 1/3 (2 ECM)                             |                |
|                                  | Rpm  | 300-1100   | 300-1100                                | 300-1100                                |                |
|                                  | Watts (total)                                | 100-820  | 100-820                                 | 100-820                                 |                |
|                                  | Diameter (Number) - in.                      | (2) 24   | (2) 24                                  | (2) 24                                  |                |
|                                  | Blades                                       | 3  | 3                                       | 3                                       |                |
|                                  | Total Air volume - cfm                       | 2000-7500  | 2000-7500                               | 2000-7500                               |                |
| Indoor Coil                      | Net face area - ft. <sup>2</sup> (total)     | 13.5   | 13.5                                    | 13.5                                    |                |
|                                  | Tube diameter - in.                          | 3/8  | 3/8                                     | 3/8                                     |                |
|                                  | Rows   | 4  | 4                                       | 4                                       |                |
|                                  | Fins - in.                                   | 14   | 14                                      | 14                                      |                |
|                                  | Condensate drain size (NPT) - in.            | (1) 1  |   |   |                |
|                                  | Expansion device type                        | Balanced Port Thermostatic Expansion Valve           |   |   |                |
| Indoor Blower                    | Nominal motor output                         | 3.75 HP (ECM)  | 3.75 HP (ECM)                           | 3.75 HP (ECM)                           |                |
|                                  | Blower wheel nominal diameter x width - in.  | (1) 22 x 19  | (1) 22 x 19                             | (1) 22 x 19                             |                |
| Filters                          | Type of filter                               | MERV 4, Disposable                                   |   |   |                |
|                                  | Number and size - in.                        | (4) 20 x 25 x 2                                      |   |   |                |
| Electrical characteristics       |  | 208/230-3-60,<br>460-3-60,<br>575-3-60               |   |   |                |

NOTE - Net capacity includes evaporator blower motor heat deduction. Gross capacity does not include evaporator blower motor heat deduction.

<sup>1</sup> AHRI Certified to AHRI Standard 340/360:

**Cooling Ratings** - 95°F outdoor air temperature and 80°F db/67°F wb entering indoor coil air.

**High Temperature Heating Ratings** - 47°F db/43°F wb outdoor air temperature and 70°F entering indoor coil air.

**Low Temperature Heating Ratings** - 17°F db/15°F wb outdoor air temperature and 70°F entering indoor coil air.

| SPECIFICATIONS                                     |  | 10 TON   12.5 TON                                    |                                       |                |
|--|--|--|---------------------------------------|----------------|
| Model  |  | LDT120H5E  | LDT152H5E                             |                |
| <b>Nominal Tonnage</b>                             |  | 10 Ton   | 12.5 Ton                              |                |
| <b>Efficiency Type</b>                             |  | High   | High                                  |                |
| <b>Blower Type</b>                                 |  | DirectPlus™ ECM Direct Drive with VAV                | DirectPlus™ ECM Direct Drive with VAV |                |
| <b>Cooling Performance</b>                         | Gross Cooling Capacity - Btuh                | 119,000  | 140,000                               |                |
|  | <sup>1</sup> Net Cooling Capacity - Btuh     | 116,000  | 136,000                               |                |
|  | AHRI Rated Air Flow - cfm                    | 3500   | 4100                                  |                |
|  | <sup>1</sup> EER (Btuh/Watt)                 | 16.6   | 15.0                                  |                |
|  | <sup>1</sup> IEER (Btuh/Watt)                | 11.8   | 10.9                                  |                |
|  | Total Unit Power (kW)                        | 10.1   | 12.7                                  |                |
| <b>Heating Performance</b>                         | <sup>1</sup> Total High Heat Capacity - Btuh | 112,000  | 128,000                               |                |
|  | <sup>1</sup> AHRI Rated Air Flow - cfm       | 3600   | 4100                                  |                |
|  | <sup>1</sup> C.O.P.                          | 3.5  | 3.35                                  |                |
|  | Total Unit Power (kW)                        | 9.3  | 11.4                                  |                |
|  | <sup>1</sup> Total Low Heat Capacity - Btuh  | 63,000   | 73,000                                |                |
|  | <sup>1</sup> C.O.P.                          | 2.25   | 2.1                                   |                |
|  | Total Unit Power (kW)                        | 8.3  | 10.4                                  |                |
| <b>Sound Rating Number</b>                         | dBA  | 88   | 87                                    |                |
| <b>Refrigerant Charge</b>                          | Refrigerant Type                             | R-454B   | R-454B                                |                |
|  | Without Reheat Option                        | Circuit 1  | 10 lbs. 11 oz.                        | 15 lbs. 0 oz.  |
|  |  | Circuit 2  | 10 lbs. 10 oz.                        | 12 lbs. 12 oz. |
| <b>Gas Heating Options Available - See page 37</b> |  | Standard (2 stage), Medium (2 Stage), High (2 Stage) |                                       |                |
| <b>Compressor Type (number)</b>                    |  | Two-Stage Scroll (1)<br>Single-Stage Scroll (1)      |                                       |                |
| <b>Outdoor Coil</b>                                | Net face area (total) - sq. ft.              | 25.9   | 29.4                                  |                |
|  | Tube diameter - in.                          | 3/8  | 3/8                                   |                |
|  | Number of rows                               | 3  | 3                                     |                |
|  | Fins per inch                                | 20   | 20                                    |                |
| <b>Outdoor Coil Fans</b>                           | Motor HP (number and type)                   | 1/3 (2 ECM)  | 1/3 (4 ECM)                           |                |
|  | Rpm  | 300-1100   | 300-1100                              |                |
|  | Watts (total)                                | 100-820  | 200-1400                              |                |
|  | Diameter (Number) - in.                      | (2) 24   | (4) 24                                |                |
|  | Blades                                       | 3  | 3                                     |                |
|  | Total Air volume - cfm                       | 2000-7500  | 3000-9000                             |                |
| <b>Indoor Coil</b>                                 | Net face area - ft. <sup>2</sup> (total)     | 13.54  | 13.54                                 |                |
|  | Tube diameter - in.                          | 3/8  | 3/8                                   |                |
|  | Rows   | 4  | 4                                     |                |
|  | Fins - in.                                   | 14   | 14                                    |                |
|  | Condensate drain size (NPT) - in.            | (1) 1  |                                       |                |
|  | Expansion device type                        | Balanced Port Thermostatic Expansion Valve           |                                       |                |
| <b>Indoor Blower</b>                               | Nominal motor output                         | 3.75 HP (ECM)  | 3.75 HP (ECM)                         |                |
|  | Blower wheel nominal diameter x width - in.  | (1) 22 x 9   | (1) 22 x 9                            |                |
| <b>Filters</b>                                     | Type of filter                               | MERV 4, Disposable                                   |                                       |                |
|  | Number and size - in.                        | (4) 20 x 25 x 2                                      |                                       |                |
| <b>Electrical characteristics</b>                  |  | 208/230-3-60,<br>460-3-60,<br>575-3-60               |                                       |                |

NOTE - Net capacity includes evaporator blower motor heat deduction. Gross capacity does not include evaporator blower motor heat deduction.

<sup>1</sup> AHRI Certified to AHRI Standard 340/360:

**Cooling Ratings** - 95°F outdoor air temperature and 80°F db/67°F wb entering indoor coil air.

**High Temperature Heating Ratings** - 47°F db/43°F wb outdoor air temperature and 70°F entering indoor coil air.

**Low Temperature Heating Ratings** - 17°F db/15°F wb outdoor air temperature and 70°F entering indoor coil air.

**SPECIFICATIONS****GAS HEAT**

|  |                     |                                  | <b>Standard</b>          | <b>Medium</b> | <b>High</b>  |
|--|---------------------|----------------------------------|--------------------------|---------------|--------------|
|  |                     | <b>Heat Input Type</b>           |                          |               |              |
|  |                     | <b>Number of Gas Heat Stages</b> | <b>2</b>                 | <b>2</b>      | <b>2</b>     |
| Gas Heating Performance                      | Input - Btuh        | First Stage                      | 85,000                   | 117,000       | 156,000      |
|  |                     | Second Stage                     | 130,000                  | 180,000       | 240,000      |
|  | Output - Btuh       | Second Stage                     | 105,000                  | 146,000       | 194,000      |
| Temperature Rise Range - °F                  |                     |                                  | 15 - 45                  | 30 - 60       | 40 - 70      |
| Minimum Air Volume - cfm                     |                     |                                  | 2150                     | 2250          | 2600         |
| Thermal Efficiency                           |                     |                                  | 81%                      | 81%           | 81%          |
| Gas Supply Connections                       |                     |                                  | 3/4 in. NPT              | 3/4 in. NPT   | 3/4 in. NPT. |
| Recommended Gas Supply Pressure - Nat. / LPG |                     |                                  | 7 in. w.g. / 11 in. w.g. |               |              |
| Gas Supply Pressure Range                    | Min./Max. (Natural) |                                  | 4.7 - 10.5 in. w.g.      |               |              |
|  | Min./Max. (LPG)     |                                  | 10.8 - 13.5 in. w.g.     |               |              |

**HIGH ALTITUDE DERATE**

**NOTE** - Units may be installed at altitudes up to 2000 feet above sea level without any modifications.

At altitudes above 2000 feet units must be derated to match gas manifold pressures shown in table below.

At altitudes above 4500 feet unit must be derated 4% for each 1000 feet above sea level.

**NOTE** - This is the only permissible derate for these units.

Refer to the Installation Instructions for more detailed information.

| Heat Input Type    | Altitude Feet | Gas Manifold Pressure<br>in. w.g. |              | Input Rate (Btuh) |
|--------------------|---------------|-----------------------------------|--------------|-------------------|
|                    |               | Natural Gas                       | LPG/ Propane |                   |
| Standard (2 stage) | 2001 - 4500   | 1.6 / 3.1                         | 4.4 / 8.9    | 84,500 / 120,000  |
| Medium (2 stage)   | 2001 - 4500   | 1.6 / 3.1                         | 4.4 / 8.9    | 117,000 / 166,000 |
| High (2 stage)     | 2001 - 4500   | 1.6 / 3.1                         | 4.4 / 8.9    | 156,000 / 221,000 |

## BLOWER DATA

**BLOWER TABLE INCLUDES RESISTANCE FOR BASE UNIT ONLY (NO HEAT SECTION) WITH DRY INDOOR COIL AND AIR FILTERS IN PLACE.**

FOR ALL UNITS ADD:

- 1 – Wet indoor coil air resistance of selected unit.
- 2 – Any factory installed options air resistance (heat section, Economizer, etc.)
- 3 – Any field installed accessories air resistance (duct resistance, diffuser, etc.)

See page 10 for wet coil and option/accessory air resistance data.

**Maximum Static Pressure With Gas Heat - 2.0 in. w.g.**

**Minimum Air Volume Required For Different Gas Heat Sizes:**

Standard - 2150 cfm; Medium - 2250 cfm; High - 2600 cfm

| Total Air Volume cfm | Total Static Pressure - in. w.g. |       |      |       |      |       |      |       |      |       |      |       |      |       |
|----------------------|----------------------------------|-------|------|-------|------|-------|------|-------|------|-------|------|-------|------|-------|
|                      | 0.2                              |       | 0.4  |       | 0.6  |       | 0.8  |       | 1.0  |       | 1.2  |       | 1.4  |       |
|                      | RPM                              | Watts | RPM  | Watts | RPM  | Watts | RPM  | Watts | RPM  | Watts | RPM  | Watts | RPM  | Watts |
| 1750                 | 644                              | 137   | 740  | 235   | 796  | 302   | 833  | 343   | 873  | 373   | 996  | 558   | 1065 | 664   |
| 2000                 | 675                              | 165   | 768  | 260   | 821  | 330   | 861  | 386   | 960  | 507   | 1026 | 629   | 1094 | 753   |
| 2250                 | 711                              | 195   | 803  | 290   | 856  | 375   | 901  | 497   | 991  | 564   | 1058 | 703   | 1128 | 840   |
| 2500                 | 764                              | 241   | 852  | 335   | 904  | 439   | 951  | 568   | 1025 | 641   | 1097 | 789   | 1170 | 934   |
| 2750                 | 847                              | 316   | 901  | 399   | 946  | 543   | 1004 | 674   | 1074 | 746   | 1146 | 895   | 1220 | 1041  |
| 3000                 | 944                              | 426   | 980  | 511   | 1021 | 671   | 1074 | 803   | 1136 | 874   | 1205 | 1021  | 1276 | 1167  |
| 3250                 | 1022                             | 544   | 1057 | 640   | 1099 | 810   | 1149 | 942   | 1207 | 1012  | 1272 | 1156  | 1338 | 1304  |
| 3500                 | 1092                             | 666   | 1131 | 770   | 1174 | 948   | 1225 | 1081  | 1281 | 1151  | 1342 | 1297  | 1402 | 1451  |
| 3750                 | 1161                             | 780   | 1202 | 892   | 1248 | 1079  | 1298 | 1217  | 1353 | 1291  | 1409 | 1445  | 1463 | 1609  |
| 4000                 | 1230                             | 888   | 1273 | 1010  | 1319 | 1212  | 1369 | 1362  | 1421 | 1441  | 1471 | 1608  | 1518 | 1784  |
| 4250                 | 1299                             | 1006  | 1342 | 1140  | 1388 | 1362  | 1436 | 1526  | 1483 | 1612  | 1528 | 1790  | 1571 | 1975  |
| 4500                 | 1366                             | 1142  | 1409 | 1289  | 1454 | 1532  | 1498 | 1708  | 1542 | 1798  | 1583 | 1984  | 1623 | 2172  |
| 4750                 | 1432                             | 1295  | 1474 | 1457  | 1516 | 1719  | 1558 | 1903  | 1598 | 1997  | 1637 | 2187  | 1674 | 2377  |
| 5000                 | 1496                             | 1471  | 1537 | 1645  | 1577 | 1921  | 1616 | 2110  | 1654 | 2205  | 1690 | 2396  | 1726 | 2586  |
| 5250                 | 1560                             | 1667  | 1598 | 1849  | 1636 | 2132  | 1673 | 2324  | 1709 | 2419  | 1744 | 2609  | 1779 | 2796  |
| 5500                 | 1623                             | 1878  | 1659 | 2064  | 1695 | 2349  | 1731 | 2539  | 1765 | 2634  | ---  | ---   | ---  | ---   |
| 5750                 | 1686                             | 2097  | 1720 | 2284  | 1755 | 2567  | ---  | ---   | ---  | ---   | ---  | ---   | ---  | ---   |
| 6000                 | 1748                             | 2316  | 1781 | 2502  | ---  | ---   | ---  | ---   | ---  | ---   | ---  | ---   | ---  | ---   |

| Total Air Volume cfm | Total Static Pressure - in. w.g. |       |      |       |      |       |      |       |      |       |      |       |
|----------------------|----------------------------------|-------|------|-------|------|-------|------|-------|------|-------|------|-------|
|                      | 1.6                              |       | 1.8  |       | 2.0  |       | 2.2  |       | 2.4  |       | 2.6  |       |
|                      | RPM                              | Watts | RPM  | Watts | RPM  | Watts | RPM  | Watts | RPM  | Watts | RPM  | Watts |
| 1750                 | 1134                             | 775   | 1203 | 896   | 1275 | 1025  | 1356 | 1149  | 1422 | 1287  | 1470 | 1439  |
| 2000                 | 1162                             | 878   | 1231 | 1007  | 1302 | 1139  | 1379 | 1268  | 1440 | 1411  | 1486 | 1570  |
| 2250                 | 1198                             | 975   | 1268 | 1111  | 1338 | 1250  | 1409 | 1388  | 1464 | 1542  | 1507 | 1711  |
| 2500                 | 1243                             | 1075  | 1313 | 1217  | 1380 | 1365  | 1442 | 1517  | 1491 | 1685  | 1533 | 1860  |
| 2750                 | 1293                             | 1186  | 1361 | 1336  | 1423 | 1494  | 1477 | 1661  | 1520 | 1839  | 1561 | 2016  |
| 3000                 | 1346                             | 1317  | 1410 | 1474  | 1466 | 1642  | 1514 | 1818  | 1554 | 2000  | 1594 | 2180  |
| 3250                 | 1402                             | 1460  | 1460 | 1627  | 1511 | 1803  | 1553 | 1986  | 1591 | 2172  | 1631 | 2352  |
| 3500                 | 1459                             | 1616  | 1509 | 1793  | 1555 | 1976  | 1594 | 2165  | 1631 | 2352  | 1671 | 2531  |
| 3750                 | 1512                             | 1785  | 1557 | 1970  | 1599 | 2159  | 1636 | 2350  | 1673 | 2536  | 1713 | 2714  |
| 4000                 | 1562                             | 1969  | 1604 | 2157  | 1643 | 2347  | 1680 | 2538  | 1717 | 2722  | 1756 | 2896  |
| 4250                 | 1611                             | 2163  | 1650 | 2352  | 1688 | 2541  | 1724 | 2729  | 1762 | 2908  | ---  | ---   |
| 4500                 | 1661                             | 2362  | 1698 | 2552  | 1734 | 2739  | 1770 | 2922  | ---  | ---   | ---  | ---   |
| 4750                 | 1710                             | 2567  | 1746 | 2754  | ---  | ---   | ---  | ---   | ---  | ---   | ---  | ---   |
| 5000                 | 1761                             | 2774  | ---  | ---   | ---  | ---   | ---  | ---   | ---  | ---   | ---  | ---   |

## BLOWER DATA

### FACTORY INSTALLED OPTIONS/FIELD INSTALLED ACCESSORY AIR RESISTANCE - in. w.g.

| Air Volume<br>cfm | Wet Indoor Coil |                  | Gas Heat Exchanger |                |              | Economizer | Filters |         |         | Return Air<br>Adaptor<br>Plate |
|-------------------|-----------------|------------------|--------------------|----------------|--------------|------------|---------|---------|---------|--------------------------------|
|                   | 078, 092        | 102,<br>120, 152 | Standard<br>Heat   | Medium<br>Heat | High<br>Heat |            | MERV 8  | MERV 13 | MERV 16 |                                |
| 1750              | 0.04            | 0.04             | 0.06               | 0.02           | 0.02         | 0.05       | 0.01    | 0.03    | 0.06    | 0.00                           |
| 2000              | 0.05            | 0.05             | 0.07               | 0.05           | 0.06         | 0.06       | 0.01    | 0.03    | 0.08    | 0.00                           |
| 2250              | 0.06            | 0.06             | 0.07               | 0.07           | 0.08         | 0.08       | 0.01    | 0.04    | 0.09    | 0.00                           |
| 2500              | 0.07            | 0.07             | 0.09               | 0.10           | 0.11         | 0.11       | 0.01    | 0.05    | 0.10    | 0.00                           |
| 2750              | 0.08            | 0.08             | 0.09               | 0.11           | 0.12         | 0.12       | 0.02    | 0.05    | 0.11    | 0.00                           |
| 3000              | 0.10            | 0.09             | 0.11               | 0.12           | 0.13         | 0.13       | 0.02    | 0.06    | 0.12    | 0.02                           |
| 3250              | 0.11            | 0.10             | 0.12               | 0.15           | 0.16         | 0.15       | 0.02    | 0.06    | 0.13    | 0.02                           |
| 3500              | 0.12            | 0.11             | 0.12               | 0.16           | 0.17         | 0.15       | 0.03    | 0.07    | 0.15    | 0.04                           |
| 3750              | 0.14            | 0.13             | 0.14               | 0.19           | 0.20         | 0.15       | 0.03    | 0.08    | 0.16    | 0.07                           |
| 4000              | 0.15            | 0.14             | 0.14               | 0.21           | 0.22         | 0.19       | 0.04    | 0.08    | 0.17    | 0.09                           |
| 4250              | 0.17            | 0.15             | 0.14               | 0.24           | 0.28         | 0.19       | 0.04    | 0.09    | 0.19    | 0.11                           |
| 4500              | 0.19            | 0.17             | 0.15               | 0.26           | 0.32         | 0.22       | 0.04    | 0.09    | 0.20    | 0.12                           |
| 4750              | 0.20            | 0.18             | 0.16               | 0.29           | 0.37         | 0.25       | 0.05    | 0.10    | 0.21    | 0.16                           |
| 5000              | 0.22            | 0.20             | 0.16               | 0.34           | 0.43         | 0.29       | 0.06    | 0.10    | 0.23    | 0.18                           |
| 5250              | 0.24            | 0.22             | 0.16               | 0.37           | 0.47         | 0.32       | 0.06    | 0.11    | 0.24    | 0.19                           |
| 5500              | 0.25            | 0.23             | 0.18               | 0.44           | 0.54         | 0.34       | 0.07    | 0.12    | 0.25    | 0.22                           |
| 5750              | 0.27            | 0.25             | 0.19               | 0.49           | 0.59         | 0.45       | 0.07    | 0.12    | 0.27    | 0.25                           |
| 6000              | 0.29            | 0.27             | 0.20               | 0.54           | 0.64         | 0.52       | 0.08    | 0.13    | 0.28    | 0.27                           |

### POWER EXHAUST FAN PERFORMANCE

| Return Air System Static Pressure | Air Volume Exhausted |
|-----------------------------------|----------------------|
| in. w.g.                          | cfm                  |
| 0                                 | 3175                 |
| 0.05                              | 2955                 |
| 0.10                              | 2685                 |
| 0.15                              | 2410                 |
| 0.20                              | 2165                 |
| 0.25                              | 1920                 |
| 0.30                              | 1420                 |
| 0.35                              | 1200                 |

## BLOWER DATA

### CEILING DIFFUSERS AIR RESISTANCE - in. w.g.

| Unit Size | RTD11 Step-Down Diffuser |             |                        | FD11 Flush Diffuser |                          |
|-----------|--------------------------|-------------|------------------------|---------------------|--------------------------|
|           | Air Volume<br>cfm        | 2 Ends Open | 1 Side, 2 Ends<br>Open |                     | All Ends & Sides<br>Open |
| 078 & 092 | 2400                     | 0.21        | 0.18                   | 0.15                | 0.14                     |
|           | 2600                     | 0.24        | 0.21                   | 0.18                | 0.17                     |
|           | 2800                     | 0.27        | 0.24                   | 0.21                | 0.20                     |
|           | 3000                     | 0.32        | 0.29                   | 0.25                | 0.25                     |
|           | 3200                     | 0.41        | 0.37                   | 0.32                | 0.31                     |
|           | 3400                     | 0.50        | 0.45                   | 0.39                | 0.37                     |
|           | 3600                     | 0.61        | 0.54                   | 0.48                | 0.44                     |
|           | 3800                     | 0.73        | 0.63                   | 0.57                | 0.51                     |
| 102 & 120 | 3600                     | 0.36        | 0.28                   | 0.23                | 0.15                     |
|           | 3800                     | 0.40        | 0.32                   | 0.26                | 0.18                     |
|           | 4000                     | 0.44        | 0.36                   | 0.29                | 0.21                     |
|           | 4200                     | 0.49        | 0.40                   | 0.33                | 0.24                     |
|           | 4400                     | 0.54        | 0.44                   | 0.37                | 0.27                     |
|           | 4600                     | 0.60        | 0.49                   | 0.42                | 0.31                     |
|           | 4800                     | 0.65        | 0.53                   | 0.46                | 0.35                     |
|           | 5000                     | 0.69        | 0.58                   | 0.50                | 0.39                     |
| 152       | 5200                     | 0.75        | 0.62                   | 0.54                | 0.43                     |
|           | 4200                     | 0.22        | 0.19                   | 0.16                | 0.10                     |
|           | 4400                     | 0.28        | 0.24                   | 0.20                | 0.12                     |
|           | 4600                     | 0.34        | 0.29                   | 0.24                | 0.15                     |
|           | 4800                     | 0.40        | 0.34                   | 0.29                | 0.19                     |
|           | 5000                     | 0.46        | 0.39                   | 0.34                | 0.23                     |
|           | 5200                     | 0.52        | 0.44                   | 0.39                | 0.27                     |
|           | 5400                     | 0.58        | 0.49                   | 0.43                | 0.31                     |
| 5600      | 0.64                     | 0.54        | 0.47                   | 0.35                |                          |
| 5800      | 0.70                     | 0.59        | 0.51                   | 0.39                |                          |

### CEILING DIFFUSER AIR THROW DATA

| Model No.          | Air Volume<br>cfm | <sup>1</sup> Effective Throw Range |            |
|--------------------|-------------------|------------------------------------|------------|
|                    |                   | RTD11 Step-Down                    | FD11 Flush |
|                    |                   | ft.                                | ft.        |
| 078, 092<br>Models | 2600              | 24 - 29                            | 19 - 24    |
|                    | 2800              | 25 - 30                            | 20 - 28    |
|                    | 3000              | 27 - 33                            | 21 - 29    |
|                    | 3200              | 28 - 35                            | 22 - 29    |
|                    | 3400              | 30 - 37                            | 22 - 30    |
| 102, 120<br>Models | 3600              | 25 - 33                            | 22 - 29    |
|                    | 3800              | 27 - 35                            | 22 - 30    |
|                    | 4000              | 29 - 37                            | 24 - 33    |
|                    | 4200              | 32 - 40                            | 26 - 35    |
|                    | 4400              | 34 - 42                            | 28 - 37    |
| 152<br>Models      | 5600              | 39 - 49                            | 28 - 37    |
|                    | 5800              | 42 - 51                            | 29 - 38    |
|                    | 6000              | 44 - 54                            | 40 - 50    |
|                    | 6200              | 45 - 55                            | 42 - 51    |
|                    | 6400              | 46 - 55                            | 43 - 52    |
|                    | 6600              | 47 - 56                            | 45 - 56    |

<sup>1</sup> Throw is the horizontal or vertical distance an air stream travels on leaving the outlet or diffuser before the maximum velocity is reduced to 50 ft. per minute. Four sides open.

**ELECTRICAL DATA****6.5 TON**

| Model No.  |                                   | LDT078H5E    |          |          |
|--|-----------------------------------|--------------|----------|----------|
|  |                                   | 208/230V-3ph | 460V-3ph | 575V-3ph |
| <b><sup>1</sup> Voltage - 60Hz</b>                       |                                   |              |          |          |
| Compressor 1<br>(Non-Inverter)                           | Rated Load Amps                   | 11.9         | 6.8      | 4.8      |
|  | Locked Rotor Amps                 | 112          | 61.8     | 39       |
| Compressor 2<br>(Non-Inverter)                           | Rated Load Amps                   | 9            | 4.1      | 3.3      |
|  | Locked Rotor Amps                 | 70           | 39       | 29       |
| Outdoor Fan<br>Motors (2)                                | Full Load Amps (2 ECM)            | 2.8          | 1.4      | 1.1      |
|  | Total                             | 5.6          | 2.8      | 2.2      |
| Power Exhaust<br>(1) 0.33 HP                             | Full Load Amps                    | 2.4          | 1.3      | 1        |
| Service Outlet 115V GFI (amps)                           |                                   | 15           | 15       | 20       |
| Indoor Blower<br>Motor                                   | HP                                | 3.75         | 3.75     | 3.75     |
|  | Full Load Amps                    | 8            | 4.2      | 3.6      |
| <sup>2</sup> Maximum<br>Overcurrent<br>Protection (MOCP) | Unit Only                         | 45           | 25       | 20       |
|  | With (1) 0.33 HP<br>Power Exhaust | 50           | 25       | 20       |
| <sup>3</sup> Minimum<br>Circuit<br>Ampacity (MCA)        | Unit Only                         | 38           | 20       | 16       |
|  | With (1) 0.33 HP<br>Power Exhaust | 40           | 21       | 17       |

NOTE - All units have a minimum Short Circuit Current Rating (SCCR) of 5000 amps.

<sup>1</sup> Extremes of operating range are plus and minus 10% of line voltage.<sup>2</sup> HACR type breaker or fuse.<sup>3</sup> Refer to National or Canadian Electrical Code manual to determine wire, fuse and disconnect size requirements.**ELECTRICAL DATA****7.5 TON**

| Model No.  |                                   | LDT092H5E    |          |          |
|--|-----------------------------------|--------------|----------|----------|
|  |                                   | 208/230V-3ph | 460V-3ph | 575V-3ph |
| <b><sup>1</sup> Voltage - 60Hz</b>                       |                                   |              |          |          |
| Compressor 1<br>(Non-Inverter)                           | Rated Load Amps                   | 11.9         | 6.8      | 4.8      |
|  | Locked Rotor Amps                 | 112          | 61.8     | 39       |
| Compressor 2<br>(Non-Inverter)                           | Rated Load Amps                   | 12.8         | 6        | 5.8      |
|  | Locked Rotor Amps                 | 120.4        | 49.4     | 41       |
| Outdoor Fan<br>Motors (2)                                | Full Load Amps (2 ECM)            | 2.8          | 1.4      | 1.1      |
|  | Total                             | 5.6          | 2.8      | 2.2      |
| Power Exhaust<br>(1) 0.33 HP                             | Full Load Amps                    | 2.4          | 1.3      | 1        |
| Service Outlet 115V GFI (amps)                           |                                   | 15           | 15       | 20       |
| Indoor Blower<br>Motor                                   | Horsepower                        | 3.75         | 3.75     | 3.75     |
|  | Full Load Amps                    | 8            | 4.2      | 3.6      |
| <sup>2</sup> Maximum<br>Overcurrent<br>Protection (MOCP) | Unit Only                         | 50           | 25       | 20       |
|  | With (1) 0.33 HP<br>Power Exhaust | 50           | 25       | 20       |
| <sup>3</sup> Minimum<br>Circuit<br>Ampacity (MCA)        | Unit Only                         | 42           | 22       | 18       |
|  | With (1) 0.33 HP<br>Power Exhaust | 44           | 23       | 19       |

NOTE - All units have a minimum Short Circuit Current Rating (SCCR) of 5000 amps.

<sup>1</sup> Extremes of operating range are plus and minus 10% of line voltage.<sup>2</sup> HACR type breaker or fuse.<sup>3</sup> Refer to National or Canadian Electrical Code manual to determine wire, fuse and disconnect size requirements.

**ELECTRICAL DATA****8.5 TON**

| Model No.  |                                   | LDT102H5E    |          |          |
|--|-----------------------------------|--------------|----------|----------|
|  |                                   | 208/230V-3ph | 460V-3ph | 575V-3ph |
| <b><sup>1</sup> Voltage - 60Hz</b>                       |                                   |              |          |          |
| Compressor 1<br>(Non-Inverter)                           | Rated Load Amps                   | 11.9         | 6.8      | 4.8      |
|  | Locked Rotor Amps                 | 112          | 61.8     | 39       |
| Compressor 2<br>(Non-Inverter)                           | Rated Load Amps                   | 16           | 7.1      | 6.4      |
|  | Locked Rotor Amps                 | 156.4        | 69       | 47.8     |
| Outdoor Fan<br>Motors (2)                                | Full Load Amps (2 ECM)            | 2.8          | 1.4      | 1.1      |
|  | Total                             | 5.6          | 2.8      | 2.2      |
| Power Exhaust<br>(1) 0.33 HP                             | Full Load Amps                    | 2.4          | 1.3      | 1        |
| Service Outlet 115V GFI (amps)                           |                                   | 15           | 15       | 20       |
| Indoor Blower<br>Motor                                   | Horsepower                        | 3.75         | 3.75     | 3.75     |
|  | Full Load Amps                    | 8            | 4.2      | 3.6      |
| <sup>2</sup> Maximum<br>Overcurrent<br>Protection (MOCP) | Unit Only                         | 60           | 25       | 25       |
|  | With (1) 0.33 HP<br>Power Exhaust | 60           | 30       | 25       |
| <sup>3</sup> Minimum<br>Circuit<br>Ampacity (MCA)        | Unit Only                         | 46           | 23       | 19       |
|  | With (1) 0.33 HP<br>Power Exhaust | 48           | 24       | 20       |

NOTE - All units have a minimum Short Circuit Current Rating (SCCR) of 5000 amps.

<sup>1</sup> Extremes of operating range are plus and minus 10% of line voltage.<sup>2</sup> HACR type breaker or fuse.<sup>3</sup> Refer to National or Canadian Electrical Code manual to determine wire, fuse and disconnect size requirements.**ELECTRICAL DATA****10 TON**

| Model No.  |                                   | LDT120H5E    |          |          |
|--|-----------------------------------|--------------|----------|----------|
|  |                                   | 208/230V-3ph | 460V-3ph | 575V-3ph |
| <b><sup>1</sup> Voltage - 60Hz</b>                       |                                   |              |          |          |
| Compressor 1<br>(Non-Inverter)                           | Rated Load Amps                   | 13.8         | 6.9      | 5.8      |
|  | Locked Rotor Amps                 | 150          | 58       | 47.8     |
| Compressor 2<br>(Non-Inverter)                           | Rated Load Amps                   | 18.6         | 8.3      | 7.7      |
|  | Locked Rotor Amps                 | 155          | 58.1     | 47.8     |
| Outdoor Fan<br>Motors (2)                                | Full Load Amps (3 ECM)            | 2.8          | 1.4      | 1.1      |
|  | Total                             | 5.6          | 2.8      | 2.2      |
| Power Exhaust<br>(1) 0.33 HP                             | Full Load Amps                    | 2.4          | 1.3      | 1        |
| Service Outlet 115V GFI (amps)                           |                                   | 15           | 15       | 20       |
| Indoor Blower<br>Motor                                   | Horsepower                        | 3.75         | 3.75     | 3.75     |
|  | Full Load Amps                    | 8            | 4.2      | 3.6      |
| <sup>2</sup> Maximum<br>Overcurrent<br>Protection (MOCP) | Unit Only                         | 60           | 30       | 25       |
|  | With (1) 0.33 HP<br>Power Exhaust | 70           | 30       | 25       |
| <sup>3</sup> Minimum<br>Circuit<br>Ampacity (MCA)        | Unit Only                         | 51           | 25       | 22       |
|  | With (1) 0.33 HP<br>Power Exhaust | 54           | 26       | 23       |

NOTE - All units have a minimum Short Circuit Current Rating (SCCR) of 5000 amps.

<sup>1</sup> Extremes of operating range are plus and minus 10% of line voltage.<sup>2</sup> HACR type breaker or fuse.<sup>3</sup> Refer to National or Canadian Electrical Code manual to determine wire, fuse and disconnect size requirements.

**ELECTRICAL DATA**

**12.5 TON**

| Model No.  |                                   | LDT152H5E    |          |          |
|--|-----------------------------------|--------------|----------|----------|
|  |                                   | 208/230V-3ph | 460V-3ph | 575V-3ph |
| <sup>1</sup> Voltage - 60Hz                              |                                   |              |          |          |
| Compressor 1<br>(Non-Inverter)                           | Rated Load Amps                   | 19.2         | 9.1      | 6.2      |
|  | Locked Rotor Amps                 | 162.3        | 70.8     | 58.2     |
| Compressor 2<br>(Non-Inverter)                           | Rated Load Amps                   | 22.4         | 9.1      | 7.2      |
|  | Locked Rotor Amps                 | 166.2        | 74.6     | 54       |
| Outdoor Fan<br>Motors (2)                                | Full Load Amps (3 ECM)            | 2.8          | 1.4      | 1.1      |
|  | Total                             | 11.2         | 5.6      | 4.4      |
| Power Exhaust<br>(1) 0.33 HP                             | Full Load Amps                    | 2.4          | 1.3      | 1        |
| Service Outlet 115V GFI (amps)                           |                                   | 15           | 15       | 20       |
| Indoor Blower<br>Motor                                   | Horsepower                        | 3.75         | 3.75     | 3.75     |
|  | Full Load Amps                    | 8            | 4.2      | 3.6      |
| <sup>2</sup> Maximum<br>Overcurrent<br>Protection (MOCP) | Unit Only                         | 80           | 35       | 30       |
|  | With (1) 0.33 HP<br>Power Exhaust | 90           | 40       | 30       |
| <sup>3</sup> Minimum<br>Circuit<br>Ampacity (MCA)        | Unit Only                         | 67           | 31       | 24       |
|  | With (1) 0.33 HP<br>Power Exhaust | 69           | 32       | 25       |

NOTE - All units have a minimum Short Circuit Current Rating (SCCR) of 5000 amps.

<sup>1</sup> Extremes of operating range are plus and minus 10% of line voltage.

<sup>2</sup> HACR type breaker or fuse.

<sup>3</sup> Refer to National or Canadian Electrical Code manual to determine wire, fuse and disconnect size requirements.

## Minimum R454B Space and CFM Requirements

| Minimum Airflow <sup>1</sup> |                        |                                      |
|------------------------------|------------------------|--------------------------------------|
| Unit                         | Q <sub>min</sub> (CFM) | Q <sub>min</sub> (m <sup>3</sup> /h) |
| LDT078                       | 304                    | 516                                  |
| LDT092                       | 297                    | 505                                  |
| LDT102                       | 297                    | 505                                  |
| LDT120                       | 283                    | 480                                  |
| LDT152                       | 396                    | 674                                  |

<sup>1</sup> **NOTE** - The minimum airflow is the lowest CFM allowed during venting operation (leak mitigation).

| Minimum Room Area of Conditioned Space <sup>2</sup> |                                      |                                     |
|---|--------------------------------------|-------------------------------------|
| Unit  | TA <sub>min</sub> (ft <sup>2</sup> ) | TA <sub>min</sub> (m <sup>2</sup> ) |
| LDT078  | 169                                  | 15.7                                |
| LDT092  | 165                                  | 15.3                                |
| LDT102  | 165                                  | 15.3                                |
| LDT120  | 157                                  | 14.5                                |
| LDT152  | 220                                  | 20.4                                |

<sup>2</sup> **NOTE** - The minimum room area of conditioned space is the smallest area the unit can service.

| Refrigerant Charge R-454B |         |                      |                     |
|---------------------------|---------|----------------------|---------------------|
| Unit                      | Stage   | M <sub>c</sub> (lbs) | M <sub>c</sub> (kg) |
| LDT 078                   | Stage 1 | 11.50                | 5.22                |
|                           | Stage 2 | 11.00                | 4.99                |
| LDT 092                   | Stage 1 | 11.00                | 4.99                |
|                           | Stage 2 | 11.25                | 5.10                |
| LDT 102                   | Stage 1 | 10.85                | 4.92                |
|                           | Stage 2 | 11.25                | 5.10                |
| LDT 120                   | Stage 1 | 10.69                | 4.85                |
|                           | Stage 2 | 10.63                | 4.82                |
| LDT 152                   | Stage 1 | 15.00                | 6.80                |
|                           | Stage 2 | 12.75                | 5.78                |

| Altitude Adjustment Factor <sup>3</sup> |      |      |      |      |      |      |      |      |      |
|---|------|------|------|------|------|------|------|------|------|
| Halt                                    | 0    | 200  | 400  | 600  | 800  | 1000 | 1200 | 1400 | 1600 |
| AF                                      | 1    | 1    | 1    | 1    | 1.02 | 1.05 | 1.04 | 1.1  | 1.12 |
| Halt                                    | 1600 | 1800 | 2000 | 2200 | 2400 | 2600 | 2800 | 3000 | 3200 |
| AF                                      | 1.12 | 1.15 | 1.18 | 1.21 | 1.25 | 1.28 | 1.32 | 1.36 | 1.4  |

<sup>3</sup> **NOTE** - Use the Altitude Adjustment Factor to adjust the values in the tables above to different altitudes. Find the relevant altitude above sea level in the two "Halt" rows and then multiply the value needed from the tables above by the altitude factor number. Example: For the minimum airflow in CFM for an LDT078 at 1000 ft. above sea level, multiply 304 by 1.05 to get 319.2 CFM as the new Q<sub>min</sub>.

# Parts Arrangement

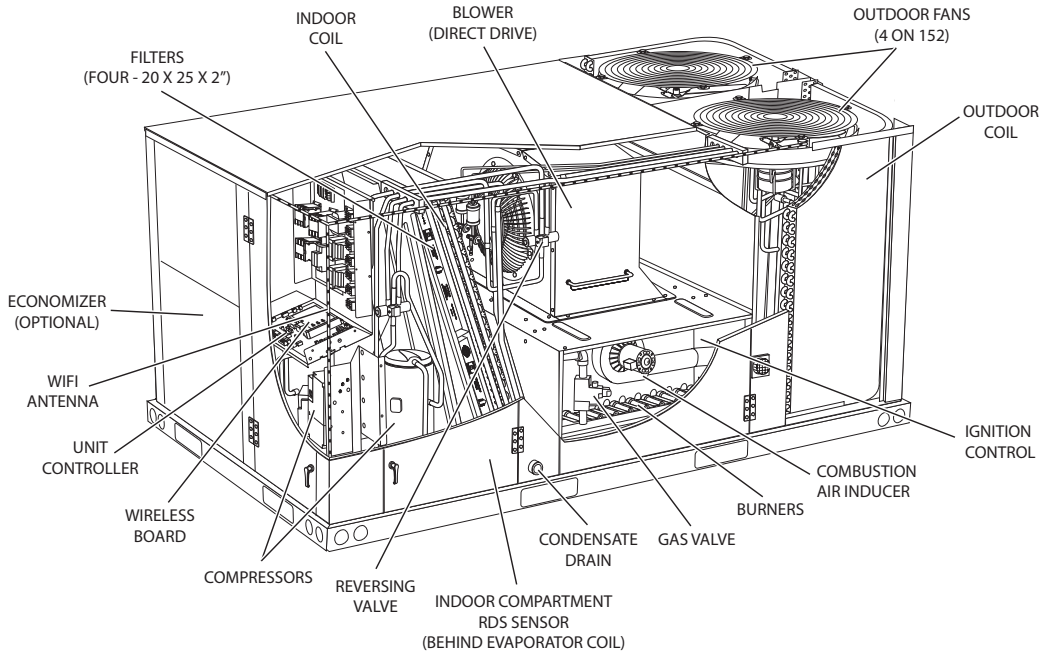

FIGURE 1

## LDT078-152 CONTROL BOX

SHADED AREA IS A HINGED PANEL IN FRONT OF CONTROLS AREA (OPTIONAL A173 LOCATION)

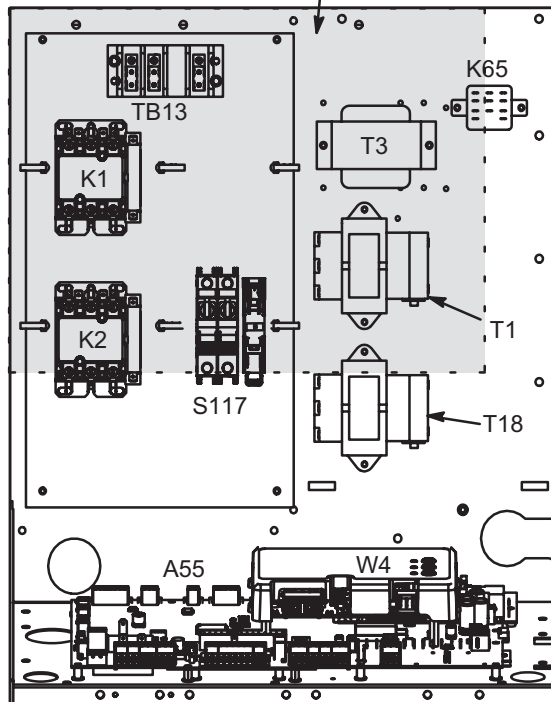



FIGURE 2

## I-UNIT COMPONENTS

|   |  |
|---|--|
| <b>⚠ WARNING</b>  |  |
|  | <b>Electric shock hazard. Can cause injury or death. Before attempting to perform any service or maintenance, turn the electrical power to unit OFF at disconnect switch(es). Unit may have multiple power supplies.</b> |

|   |
|---|
| <b>ELECTROSTATIC DISCHARGE (ESD)<br/>Precautions and Procedures</b> |
|---|

|   |  |
|---|--|
| <b>⚠ CAUTION</b>  |  |
|  | <b>Electrostatic discharge can affect electronic components. Take precautions to neutralize electrostatic charge by touching your hand and tools to metal prior to handling the control.</b> |

The LDT unit parts arrangement are shown in FIGURE 1. All L1, L2, and L3 wiring is color coded; L1 is red, L2 is yellow, and L3 is blue. See wiring diagrams in the back of this manual for complete call out of components per LDT unit. All 6.5 through 12.5 ton units are configure to order units (CTO).

### A-Control Box Components

LDT control box components are shown in FIGURE 2. The control box is located in the upper portion of the compressor compartment.

#### 1-Disconnect Switch S48 (Optional)

All units may be equipped with an optional disconnect switch S48. Other factory or field installed optional circuit breakers may be used, such as CB10. S48 and CB10 are toggle switches, which can be used by the service technician to disconnect power to the unit.

#### 2-Control Transformer T1

All use a single line voltage to 24VAC transformer mounted in the control box. Transformer supplies power to control circuits in the unit. The transformer is rated at 92VA and is protected by a 6 amp circuit breaker (CB8). The 208/230 (Y) voltage transformers use primary voltage taps as shown in FIGURE 3, while 460 (G) and 575 (J) voltage transformers use a single primary voltage tap.

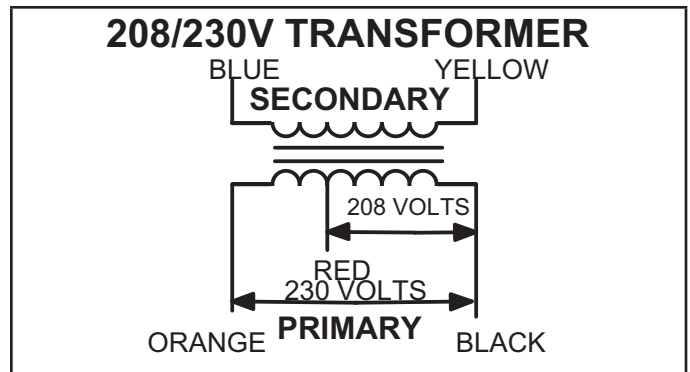

FIGURE 3

### 3-C. A. I. Transformers T3 575V Units

All LDT 575 (J) voltage units use transformer T3. The auto voltage to 230VAC transformer is mounted in the control box. The transformer has an output rating of 0.5A. T3 transformer supplies 230 VAC power to combustion air blower motor (B6).

### 4-Transformer T18

T18 is a single line voltage to 24VAC transformer used in all LDT units. T18 is rated at 70VAC and is protected by a 3.5 amp circuit breaker (CB18).

### 5-Compressor Contactor K1, K2

All compressor contactors are three-pole, double-break contactors with 24VAC coils. K1 and K2 (both energized by A55) energize compressors B1 and B2.

### 6-Power Exhaust Relay K65 (PED units)

Power exhaust relay K65 is a N.O. DPDT relay with a 24VAC coil. K65 is used in all LDT units equipped with the optional power exhaust dampers. K65 is energized by the economizer control panel (A56), after the economizer dampers reach 50% open (adjustable in CORE). When K65 closes, the exhaust fan B10 is are energized.

### 7-Terminal Block (TB13)

TB13 terminal block distributes line voltage power to the line voltage items in the unit.

# PLUMBING COMPONENTS

LDT078-120

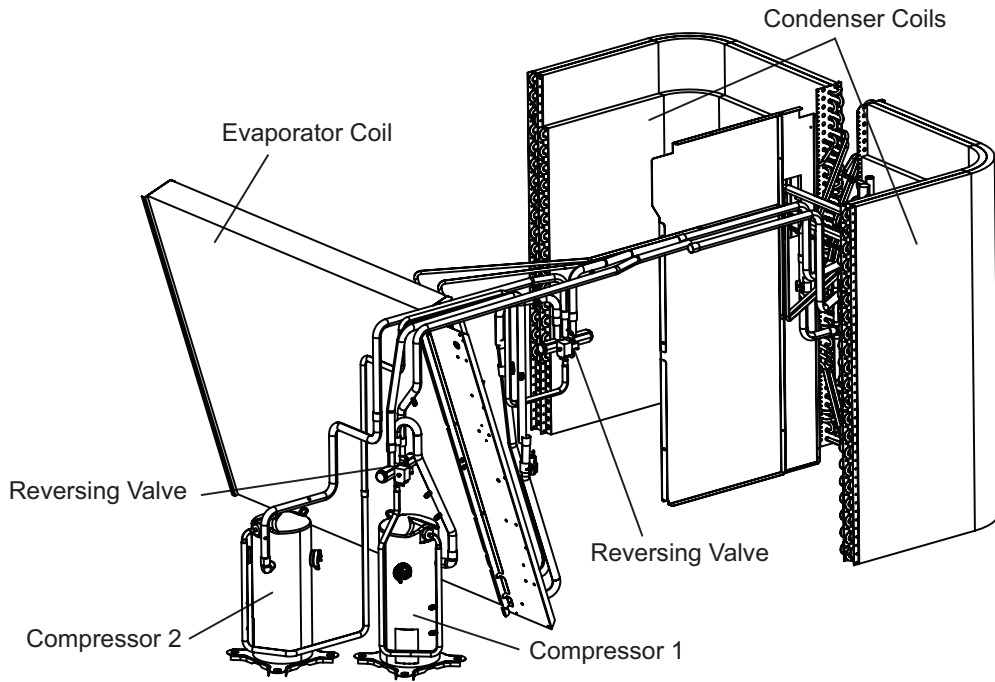

LDT152

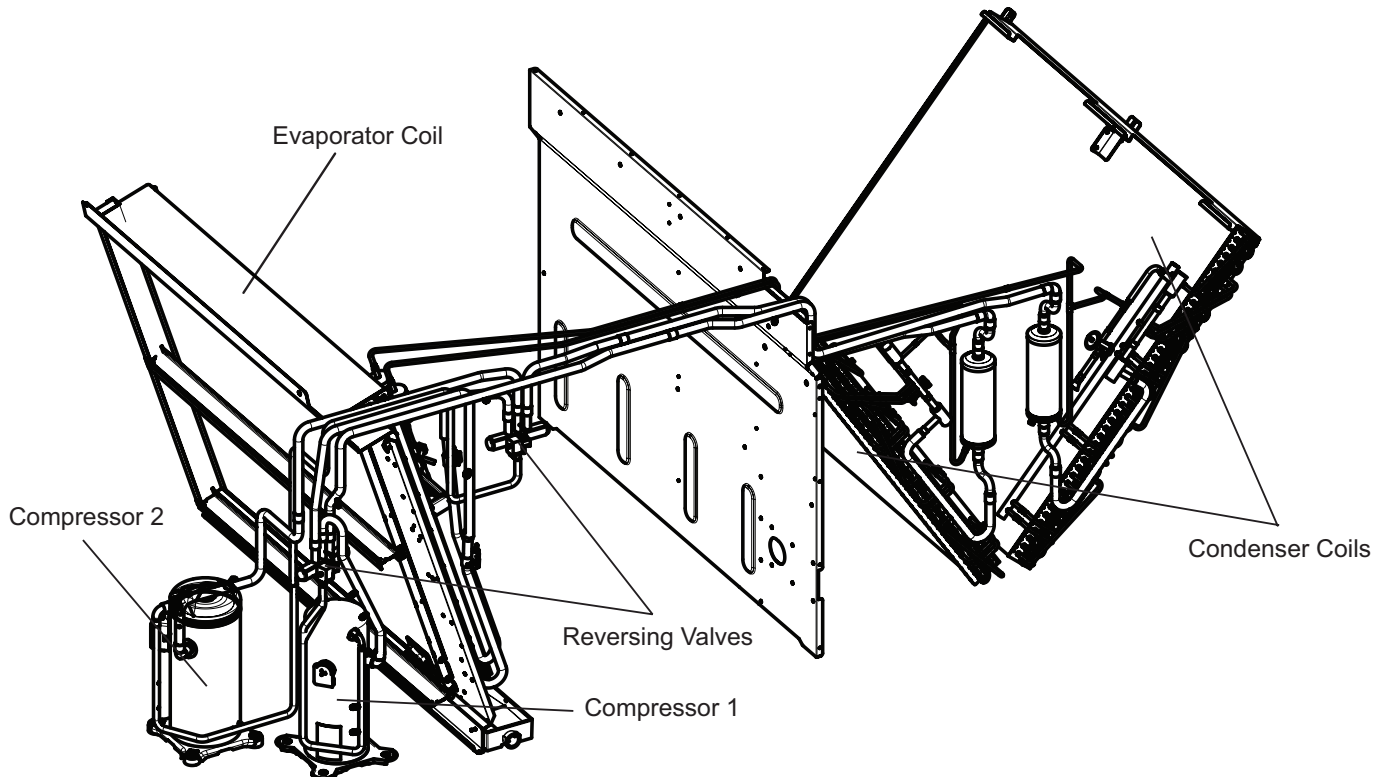

FIGURE 4

## B-Cooling Components

LDT units use independent cooling circuits consisting of separate compressors, outdoor coils and indoor coil (with 2 separate stages). See FIGURE 4. Units are equipped with two or three draw-through type condenser fans, and directdrive blowers. The blower draws air across the indoor coil during unit operation.

Cooling may be supplemented by a factory-or-field-installed economizer. The indoor coils are slab type and are stacked. Each indoor coil uses a thermostatic expansion valve as the primary expansion device. Each indoor coil is also equipped with enhanced fins and rifled tubing. In all units, each compressor is protected by a crankcase heater, high pressure switch and low pressure switch. Additional protection is provided by thermistors for low ambient control and freezing prevention.

### 1-Compressors B1 and B2

Units use two scroll compressors and two independent cooling circuits. Compressor capacity may vary from stage to stage. In all cases, the capacity of each compressor is added to reach the total capacity of the unit. See "SPECIFICATIONS" and "ELECTRICAL DATA" (table of contents) or compressor nameplate for compressor specifications.

## WARNING

**Electrical shock hazard. Compressor must be grounded. Do not operate without protective coverover terminals. Disconnect power before removing protective cover. Discharge capacitors before servicing unit. Failure to follow these precautions could cause electrical shock resulting in injury or death.**

Each compressor is energized by a corresponding compressor contactor.

**NOTE**-Refer to the wiring diagram section for specific unit operation.

## IMPORTANT

**Some scroll compressors have an internal vacuum protector that will unload scrolls when suction pressure goes below 20 psig. A hissing sound will be heard when the compressor is running unloaded. Protector will reset when low pressure in system rises above 40 psig. DO NOT REPLACE COMPRESSOR.**

### 2-High Pressure Switches S4 and S7

The high pressure switch is an auto-reset SPST N.C. switch which opens on a pressure rise. All units are equipped with this switch. On fin/tube outdoor coils, the switch is located in the compressor discharge line. On all-aluminum outdoor coils, the switch is located on the liquid line in the blower section. Switches are wired in series with the compressor contactor coil.

On standard and high efficiency units, S4 (first circuit) and

S7 (second circuit) are wired in series with the respective compressor contactor coils. On ultra high efficiency units, only S4 is used. S4 is located on the common compressor discharge line and is wired to both compressor-contactors via the A55 Unit Controller.

When discharge pressure rises to  $640 \pm 20$  psig ( $4413 \pm 138$  kPa) (indicating a problem in the system) the switch opens and the respective compressor is de-energized (the economizer can continue to operate). When discharge pressure drops to  $475 \pm 20$  psig ( $3275 \pm 138$  kPa) the pressure switch will close.

The A55 Unit Controller has a three-strike counter before locking out. This means the control allows three high pressure trips per one thermostat demand. The control can be reset by breaking and remaking the thermostat demand or manually resetting the control.

### 3-Reversing Valve L1 and L2

A refrigerant reversing valve with a 24 volt solenoid coil is used to reverse refrigerant flow during unit operation in all LDT units. The reversing valve is connected in the vapor line of the refrigerant circuit. The reversing valve coil is energized during cooling demand and during defrost.

Reversing valve L1 and L2 are controlled by the M4 controller in response to cooling demand or by defrost.

### 4-Low Pressure Switches S87, S88

The low pressure switch is an auto-reset SPST N.O. switch (held N.C. by refrigerant pressure) which opens on a pressure drop. All units are equipped with this switch. The switch is located in the compressor suction line.

S87 (compressor one) and S88 (compressor two) are wired to A55 Unit Controller. A55 governs the low pressure switches by shunting the switches during start up until pressure is stabilized. After the shunt period, the control has a three-strike counter, during first thermostat demand, before the compressor is locked out. The control is reset by breaking and remaking the thermostat demand or manually resetting the control.

When suction pressure drops to  $25 \pm 5$  psig, (indicating low pressure), the switch opens and the compressor(s) is(are) de-energized. The switch automatically resets when pressure in the suction line rises to  $40 \pm 5$  psig due to many causes such as refrigerant being added.

## **5-Defrost Control**

The defrost control ensures that the heat pump outdoor coil does not ice excessively during the heating mode. The defrost control uses input from the coil and ambient sensors to initiate demand defrost cycles from the M4 Board. If the system fails to calibrate or obtain readings for demand defrost, defrost will run-time at field setting. Electric heat is energized during defrost

## **6-Filter Drier (all units)**

LDT units have a filter drier located in the liquid line of each refrigerant circuit at the exit of each condenser coil (outdoor coil in LDT units). The drier removes contaminants and moisture from the system.

## **7-Condenser Fan Motors B4, B5, B21, B22**

See specifications section of this manual for specifications of condenser fans B4 , B5, B21, and B22 (B21 and B22 on 152 units only). All LDT motors are electrically commutated condenser fan motors (ECM). The ECM motors are wired directly to 230VAC power but do not operate until a pulse width modulated (PWM) control signal is sent from the M4 controller. All outdoor fans will run at the same speed when the appropriate PWM signal is received. The fans may be removed for servicing and cleaning by removing the fan grilles.

## **Transformer T5 and Fuse F57 460VAC & 575VAC Only:**

460VAC and 575VAC units will use a Transformer T5 to step-down the line voltage to the correct 230VAC. There are two fuses F57 located next to the T5 transformer. The location of the T5 transformer is behind the disconnect box just above the bottom power entry cover.

## **8-Crankcase Heaters HR1, HR2**

Heater HR1 is installed around compressor B1 and heater HR2 is installed around compressor B2. Crankcase heater wattage varies by compressor manufacturer.

## **9-Temperature Sensors RT46, RT47, RT48 & RT49**

Units are equipped with four factory-installed thermistors (RT46-RT49) located on different points on the refrigerant circuit.

The thermistors provide the Unit Controller with constant temperature readings of four specific locations on the refrigeration circuit. These temperatures are used as feedback in certain modes of unit operation.

Each thermistor must be specifically placed for proper unit operation and to initiate valid alarms. See FIGURE 5 and FIGURE 6 proper locations.

LDT078, 092, 102, 120, 152  
INDOOR COIL  
RT46, RT47

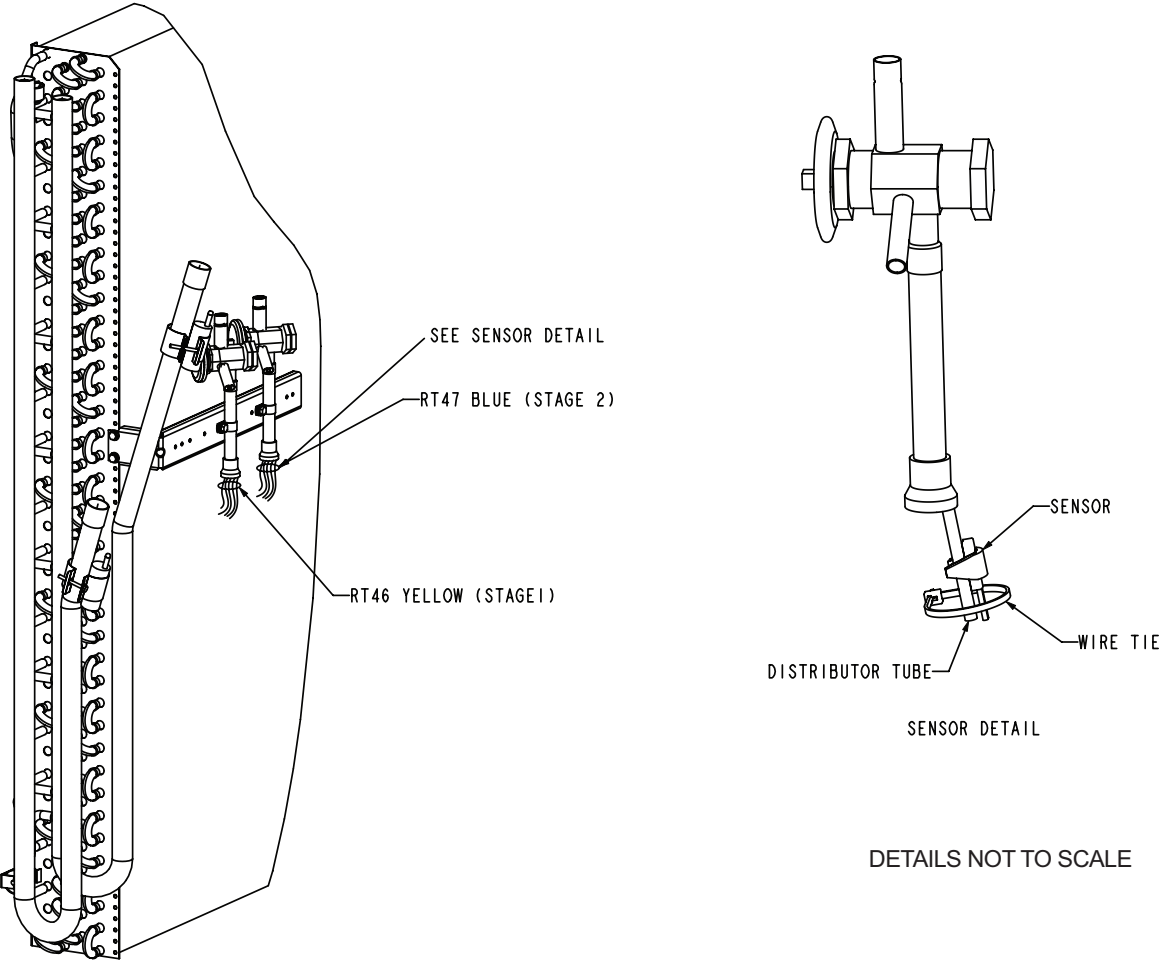
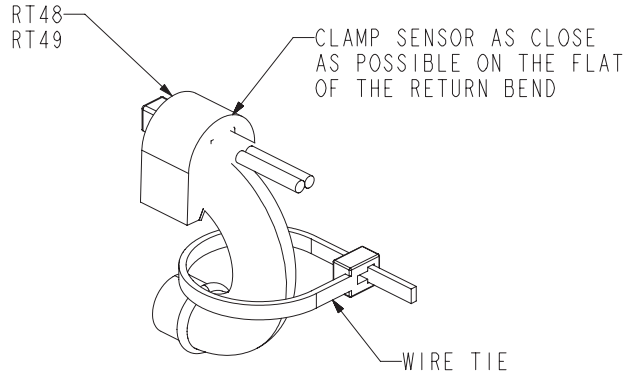

FIGURE 5

LDT078, 092, 102, 120, 152  
OUTDOOR COIL  
RT48, RT49



SENSOR DETAIL

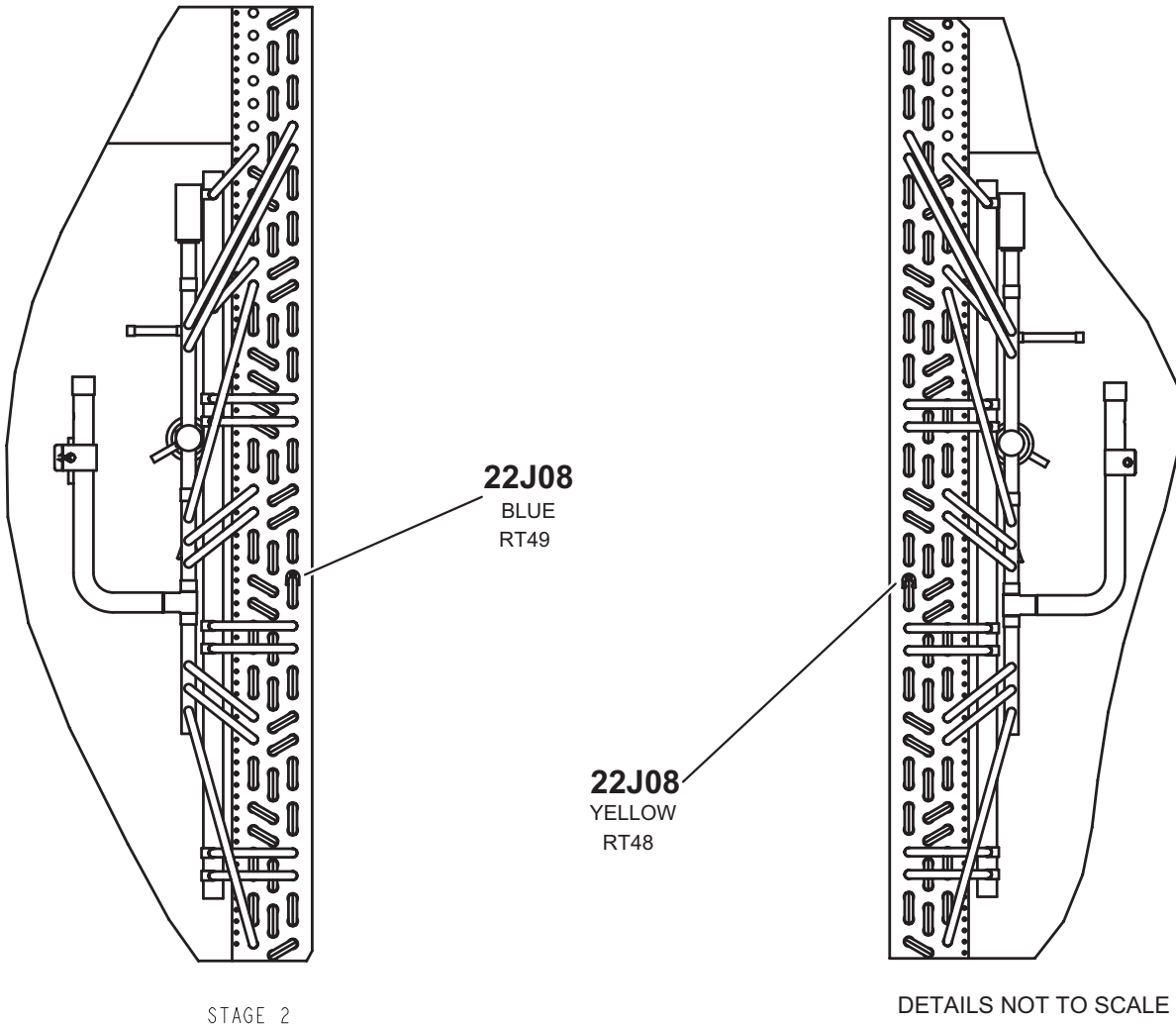

FIGURE 6

## RDS Sensors

Units are equipped with factory-installed RDS Sensors located on different points on the unit. The RDS sensors provide the Unit Controller with continuous readings for leaked refrigerant concentration levels and sensor health status (Good or Fault). These readings are used to modify unit operation to disperse the leaked refrigerant and to remove possible ignition sources. In addition, the Unit Controller uses these readings to initiate alarms to alert the operator of a refrigerant leak or faulty sensor(s).

Each sensor must be specifically placed for proper unit operation and to initiate valid alarms. To identify sensor locations see FIGURE 7.

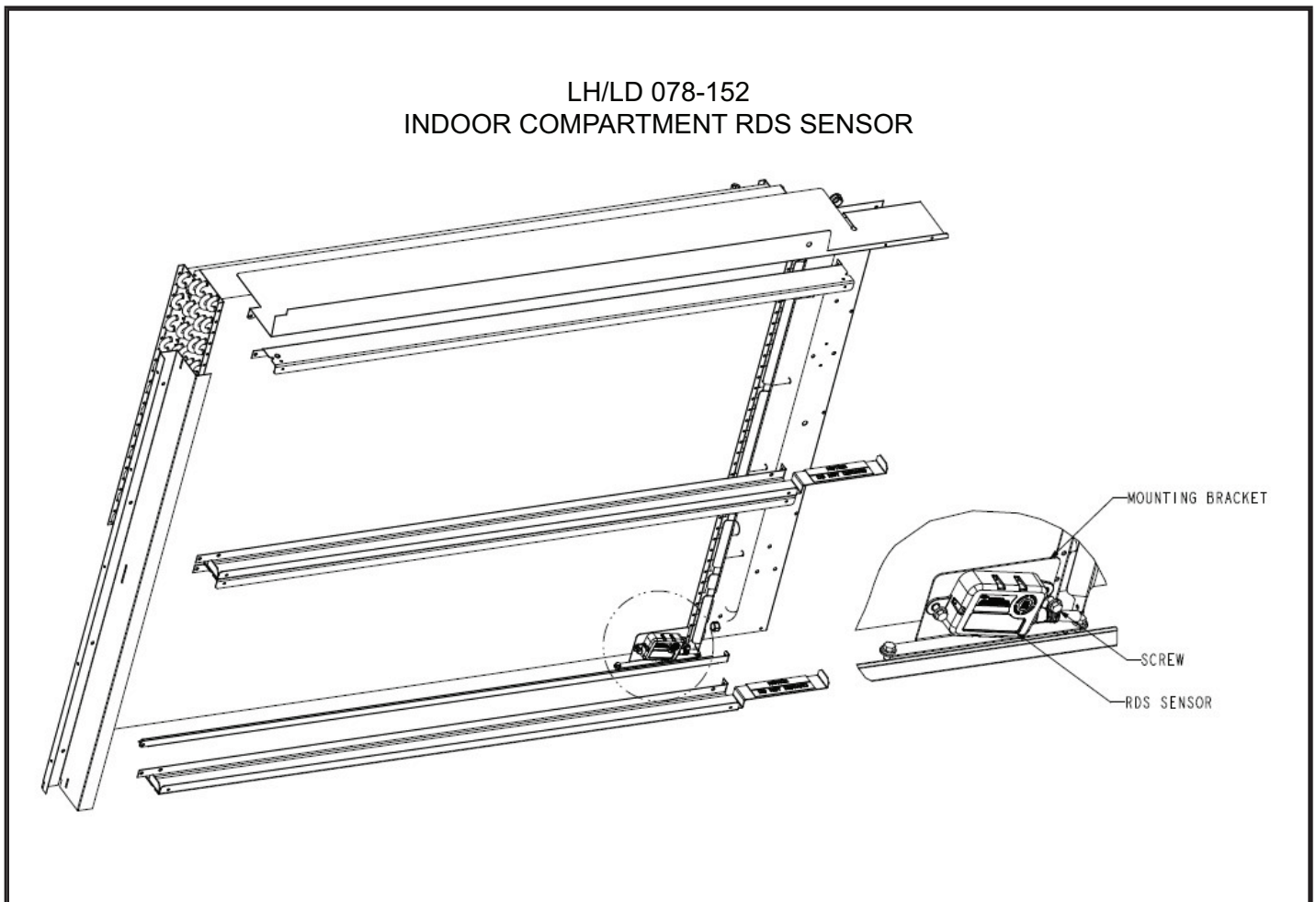

FIGURE 7

## A-Blower Compartment

The blower compartment in all LDT078-152H units is located between the indoor coil and the outdoor coil section. The blower assembly is accessed by disconnecting the blower motor and all other plugs and removing the screws in front of the blower housing.

### 1-Blower Wheels

Units are be equipped with a backward inclined blower wheel. See "SPECIFICATIONS" at the front this manual for more detail.

### 2-Indoor Blower Motor B3

Units are equipped with a direct drive blower assembly with a three-phase, variable speed, direct drive blower motor.

All motor specifications are listed in the SPECIFICATIONS (table of contents) in the front of this manual. Units may be equipped with motors manufactured by various manufacturers, therefore electrical FLA and LRA specifications will vary. See unit name plate for information specific to your unit.

### B-Blower Operation

Refer to the Unit Controller Setup Guide to energize blower. Use the mobile service app menu; see SERVICE > TEST.

In both thermostat and zone control mode, the Unit Controller will stage the blower between low and high speed.

## WARNING

- 1-Make sure that unit is installed in accordance with the installation instructions and applicable codes.
- 2-Inspect all electrical wiring, both field- and factoryinstalled, for loose connections. Tighten as required.
- 3-Check to ensure that refrigerant lines do not rub against the cabinet or against other refrigerant lines.
- 4-Check voltage at disconnect switch. Voltage must be within range listed on nameplate. If not, consult power company and have voltage condition corrected before starting unit.
- 5-Make sure filters are new and in place before start-up.

Initiate blower only (G) demand at thermostat according to instructions provided with thermostat. Unit will cycle on thermostat demand. The following steps apply to applications using a typical electro-mechanical thermostat.

- 1 - Blower operation is manually set at the thermostat subbase fan switch. With fan switch in **ON** position, blowers will operate continuously.
- 2 - With fan switch in **AUTO** position, the blowers will cycle with demand. Blowers and entire unit will be

off when system switch is in **OFF** position.

**NOTE** - Blower operation mode can also be initiated by the mobile service app.

Direct-drive motor may not immediately stop when power is interrupted to the Unit Controller. Disconnect unit power before opening the blower compartment. The Controller's digital inputs must be used to shut down the blower. See Unit Controller manual for operation sequences.

### C-Blower Access

The blower assembly is secured to a sliding frame which allows the blower assembly to be pulled out of the unit. See FIGURE 9.

- 1 - Loosen the reusable wire tie which secures the controls and high voltage blower wiring to the blower housing. Disconnect the pressure sensor low voltage wire harness.
- 2 - Remove and retain screws on either side (and on the front for direct drive) of sliding frame. Use the metal handle to pull frame toward outside of unit.
- 3 - Slide frame back into original position when finished servicing. Reattach the blower wiring in the previous location using the wire tie. Reconnect pressure sensor low voltage wire harness.
- 4 - Replace retained screws.

The supply CFM can be adjusted by changing the percentage of motor output using the Unit Controller settings Refer to TABLE 1 for menu paths and default settings.. Record any RPM% changes on the parameter settings label located on the inside of the compressor access panel.

## CAUTION

The **BLOWER CALIBRATION** process starts the indoor blower at operational speeds and moves the economizer damper blades. Before starting this process, replace any access panels and close all unit doors except compressor compartment door.

Blower calibration is required only on units that are newly installed or if there is a change in the duct work or air filters after installation. Use the mobile service app to navigate to the SETUP>TEST & BALANCE>BLOWER menu. After the new RPM% values are entered, select START CALIBRATION. The blower calibration status is displayed as a % complete. Upon successful completion, the mobile service app will display CALIBRATION SUCCESS and go back to the blower calibration screen.

**IMPORTANT** - The default value for Cooling Low motor speed is lower than a traditional single- or two-speed unit. If operating the unit with a 2- or 3-stage controller (2- or 3-stage thermostat, DDC controller, etc.), it is recommended to increase the Cooling Low CFM default value to a suitable level for part load cooling (typically 60% of full load CFM).

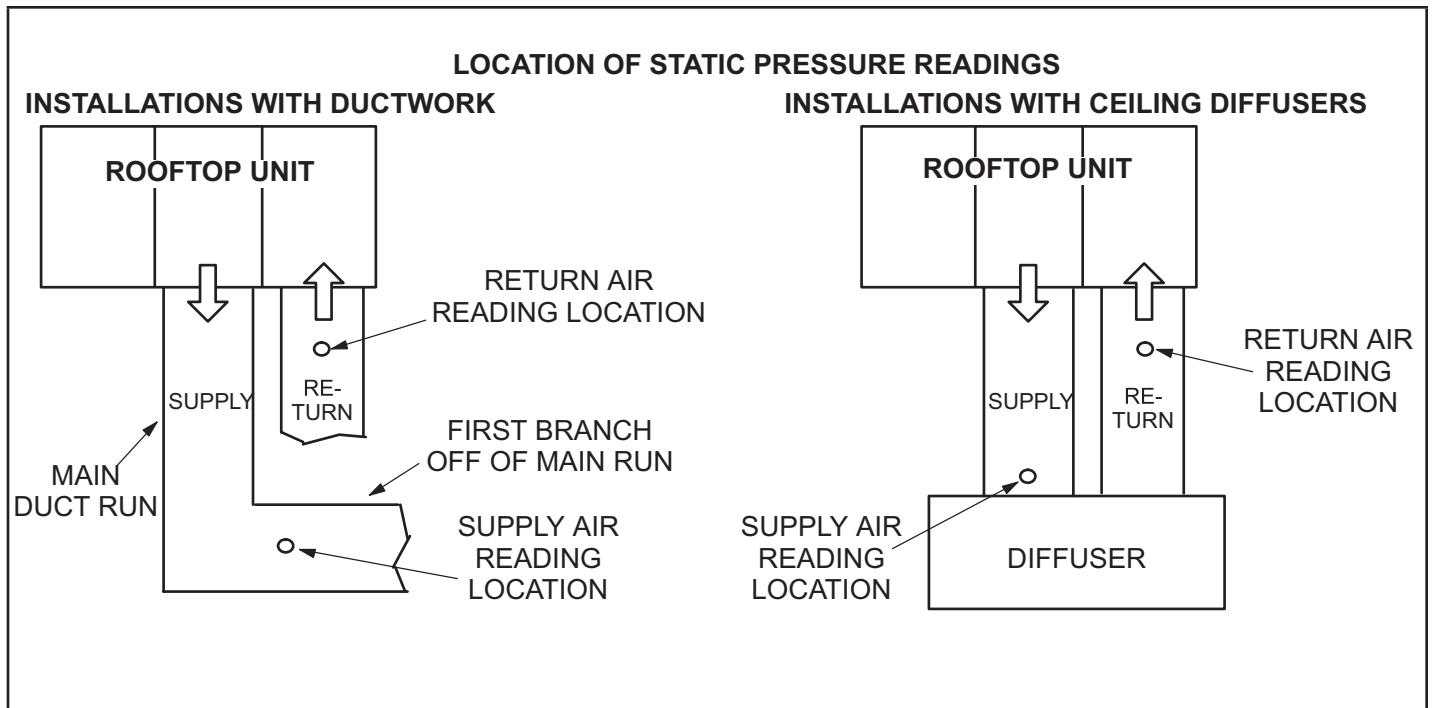

**FIGURE 8**

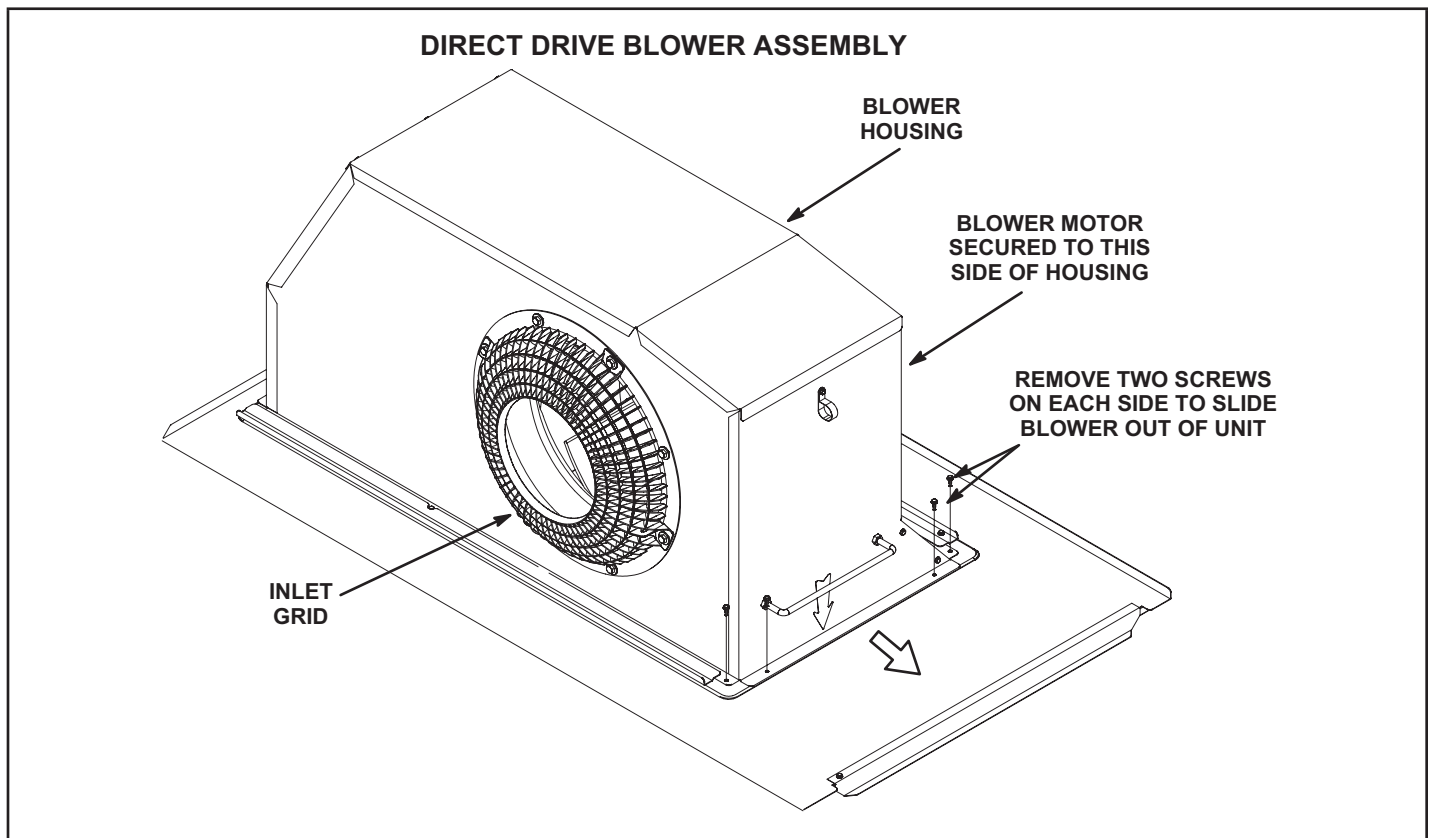

**FIGURE 9**

**TABLE 1  
DIRECT DRIVE PARAMETER SETTINGS - 581102-01**

| Parameter  | Field Setting | Description  |
|--|---------------|--|
| <b>Note: Any changes to Smoke CFM setting must be adjusted before the other CFM settings. Use SETTINGS &gt; RTU OPTIONS &gt; EDIT PARAMETERS = 12 for EBM, 6 for ECM</b> |               |  |
| BLOWER SMOKE CFM   | %             | Percentage of RPM for blower smoke speed.  |
| <b>SETUP &gt; TEST &amp; BALANCE &gt; BLOWER</b>   |               |  |
| BLOWER HEATING HIGH CFM  | %             | Percentage of RPM for blower heating high speed.   |
| BLOWER HEATING LOWCFM  | %             | Percentage of RPM for blower heating low speed (P volt gas heat only).                                       |
| BLOWER COOLING HIGH CFM  | %             | Percentage of RPM for blower cooling high speed.   |
| BLOWER COOLING LOW CFM   | %             | Percentage of RPM for blower cooling low speed and vent speed for standard static blowers.                   |
| BLOWER VENTILATION CFM   | %             | Percentage of RPM for high static blower ventilation speed.  |
| <b>SETUP &gt; TEST &amp; BALANCE &gt; DAMPER</b>   |               |  |
| BLOWER HIGH CFM DAMPER POS %   | %             | Minimum damper position for high speed blower operation. Default 0%.   |
| BLOWER LOW CFM DAMPER POS %  | %             | Minimum damper position for low speed blower operation. Default 0%.  |
| POWER EXHAUST DAMPER POS %   | %             | Minimum damper position for low power exhaust operation. Default 50%.  |
| <b>SETTINGS &gt; RTU OPTIONS &gt; EDIT PARAMETERS = 216</b>  |               |  |
| POWER EXHAUST DEADBAND %   | %             | Deadband % for power exhaust operation. Default 10%.   |
| <b>SETTINGS &gt; RTU OPTIONS &gt; EDIT PARAMETERS = 10 (Applies to Thermostat Mode ONLY)</b>   |               |  |
| FREE COOLING STAGE-UP DELAY  | sec           | Number of seconds to hold blower at low speed before switching to blower at high speed. Default 300 seconds. |

**Installer:** Record any parameter changes under "Field Setting" column. Settings need to be recorded by installer for use when Unit Controller is replaced or reprogrammed.

## D-GAS HEAT COMPONENTS

### 1-Heat Exchanger

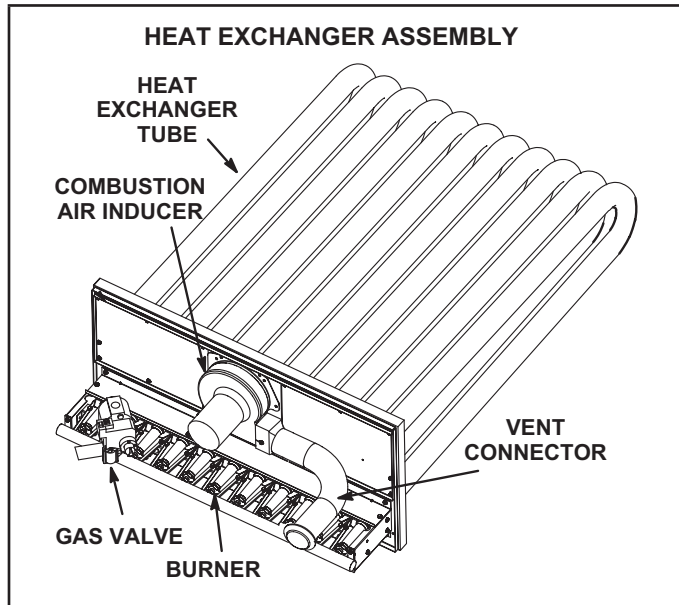

**FIGURE 10**

LDT units use inshot burners with tubular stainless steel heat exchangers and two-stage redundant gas valves. LDT092, 102, 120 and 152 units use one eleven tube/burner for high heat, one nine tube/burner for medium heat and one six tube/burner for standard heat.

LDT078 units use one nine tube/burner for medium heat and one six tube/burner for standard heat. Burners in all units use a burner venturi to mix gas and air for proper combustion.

Combustion takes place at each tube entrance. As hot combustion gases are drawn upward through each tube by the combustion air inducer, exhaust gases are drawn out the top and fresh air/gas mixture is drawn in at the bottom. Heat is transferred to the air stream from all surfaces of the heat exchanger tubes. The supply air blower forces air across the tubes to extract the heat of combustion. The shape of the tubes ensures maximum heat exchange. The gas valves accomplish staging by allowing more or less gas to the burners as called for by heating demand.

### 2-Burner Box Assembly FIGURE 11

The burners are controlled by the spark electrode, flame sensing electrode, gas valve and combustion air blower. The spark electrode, flame sensing electrode and gas valve are directly controlled by ignition control. Ignition control and combustion air blower is controlled by A55 Unit Controller.

#### ***Burners***

All units use cluster type inshot burners. Burners are factory set and do not require adjustment. A peep hole with cover is furnished in the heating access panel for flame viewing. Always operate the unit with the access panel in place.

Burners can be removed for service as an assembly. Burner maintenance and service is detailed in the SERVICE CHECKS section of this manual.

### Orifice

Each burner uses an orifice which is precisely matched to the burner input. Install only the orifices with the same threads. The orifice is threaded into the burner manifold. The burner is supported by the orifice and will easily slide off for service. Each orifice and burner are sized specifically to the unit. Refer to ProductZone@www.davenet.com for correct sizing information.

**NOTE**-Do not use thread sealing compound on the orifices. Using thread sealing compound may plug the orifices.

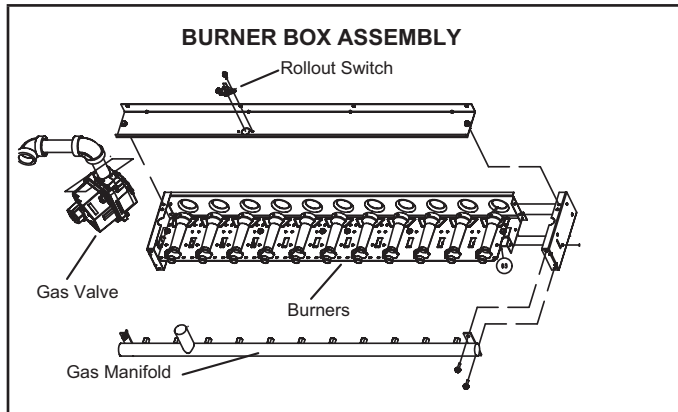

FIGURE 11

### 3-Primary High Temperature Limit S10

S10 is a SPST N.C. high temperature primary limit for gas heat and is located on the blower deck to the right of the blower deck.

Primary limit S10 is wired to the A55 unit controller. Its N.C. contacts open to de-energize the ignition control when excessive temperature is reached in the blower compartment. If the limit trips the blower will be energized. Limit settings are factory set and cannot be adjusted. If limit must be replaced, the same type and set point must be used.

### 4-Flame Roll-out Limit Switch S47

Flame roll-out limit switch S47 is a SPST N.C. high temperature limit located just above the burner air intake opening in the burner enclosures (see FIGURE 11). S47 is wired to the ignition control A3. When S47 senses flame roll-out (indicating a blockage in the combustion air passages), the flame roll-out limit trips and the ignition control immediately closes the gas valve.

Limit S47 is factory preset to open at 290F  $\pm$  12°F (143°C  $\pm$  6.7°C) on a temperature rise on all units. All flame roll-out limits are manual reset.

### 5-Combustion Air Prove Switch S18

Prove switch S18 is a SPST N.O. switch located to the right of the induced draft assembly. S18 monitors combustion air inducer operation. Switch S18 is wired to the A55 Unit controller. The switch closes on a negative pressure fall. This negative pressure fall and switch actuation allows the ignition sequence to continue (proves, by closing, that the combustion air inducer is operating before allowing the gas valve to open.) The combustion air prove switch is factory set and not adjustable. The switch will automatically open on a pressure rise (less negative pressure). TABLE 2 shows prove switch settings.

TABLE 2

S18 Prove Switch Settings

| Close" w.c. (Pa)               | Open " w.c. (Pa)               |
|--------------------------------|--------------------------------|
| 0.25 $\pm$ 5 (62.3 $\pm$ 12.4) | 0.10 $\pm$ 5 (24.8 $\pm$ 12.4) |

### 6-Combustion Air Inducer B6

The combustion air inducer provides fresh air to the burner while clearing the combustion chamber of exhaust gases. The inducer is energized by the A55 Unit Controller via K13 relay..

The inducer uses a 208/230V single-phase PSC motor and a 4.81in. x 1.25in. (122mm x 32mm) blower wheel. All motors operate at 3200RPM and are equipped with auto-reset overload protection. Inducers are supplied by various manufacturers. Ratings may vary by manufacturer. Specific inducer electrical ratings can be found on the unit rating plate.

On a heating demand (W1), the A55 unit controller initiates the heating cycle. A55 then allows 30 seconds for the combustion air inducer to vent exhaust gases from the burners.

When the combustion air inducer is purging the exhaust gases, the combustion air prove switch closes, proving that the combustion air inducer is operating before allowing the ignition sequence to continue. When the combustion air prove switch is closed and the delay is over, the ignition control activates the first stage operator of the gas valve (low fire), the spark and the flame sensing electrode. Sparking stops immediately after flame is sensed or at the end of the eight second trial for ignition. All combustion air inducer motors are sealed and cannot be oiled. The inducer cannot be adjusted but can be disassembled for cleaning.

### 7-Combustion Air Motor Capacitor C3

The combustion air inducer motors in all LDT units require run capacitors. Capacitor C3 is connected to combustion air inducer B6. Ratings will be on side of capacitor or combustion air motor nameplate.

## 8-Gas Valves GV1

Gas valve GV1 is a two-stage redundant valve. On first stage (low fire) is quick opening (on and off in less than 3 seconds). Second stage is slow opening (on to high fire pressure in 40 seconds and off to low fire pressure in 30 seconds). On a call for first stage heat (low fire), the valve is energized by the ignition control simultaneously with the spark electrode. On a call for second stage heat (high fire), the second stage operator is energized directly from A55.

The valve is adjustable for high fire only. Low fire is not adjustable. A manual shut-off knob is provided on the valve for shut-off. Manual shut-off knob immediately closes both stages without delay. FIGURE 17 shows gas valve components. TABLE 3 shows factory gas valve regulation for LDT units.

**TABLE 3**  
**GAS VALVE REGULATION FOR LDT UNITS**

| Max Inlet Pressure "W.C. | Operating Pressure "W.C. (outlet) Factory Setting |         |              |          |
|--------------------------|---|---------|--------------|----------|
|                          | Natural   |         | L.P. Propane |          |
|                          | Low   | High    | Low          | High     |
| 13.0                     | 1.6±0.2   | 3.7±0.3 | 5.5±0.3      | 10.5±0.5 |

## 9-Spark Electrodes FIGURE 12

An electrode assembly is used for ignition spark. The electrode is mounted through holes under the left most burner location. The electrode tip protrudes into the flame envelope of the adjacent burner. The electrode assembly is fastened to burner supports and can be removed for service without removing any part of the burners.

During ignition, spark travels through the spark electrode (FIGURE 12) and ignites the left burner. Flame travels from burner to burner until all are lit.

The spark electrode is connected to the ignition control by a 8 mm silicone-insulated stranded high voltage wire. The wire uses 1/4" (6.35 mm) female quick connect on both ends of the wire.

**NOTE** - If electrode wire is replaced, wire and suppression must be same type cable.

The spark electrode assembly can be removed for inspection by removing the screw securing the electrode assembly and sliding it out of unit.

For proper unit operation, electrodes must be positioned and gapped correctly.

Spark gap may be checked with appropriately sized twist drills or feeler gauges. Disconnect power to the unit and remove electrode assembly. The gap should be between 0.125" + 0.015" (3.2 mm + .4 mm). See FIGURE 12.

**NOTE**-IN ORDER TO MAXIMIZE SPARK ENERGY TO ELECTRODE, HIGH VOLTAGE WIRE SHOULD TOUCH UNIT CABINET AS LITTLE AS POSSIBLE.

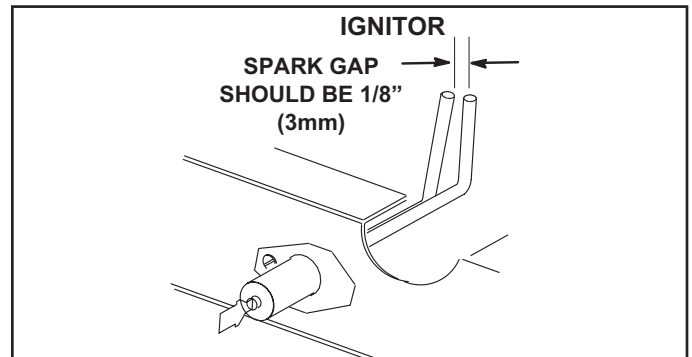
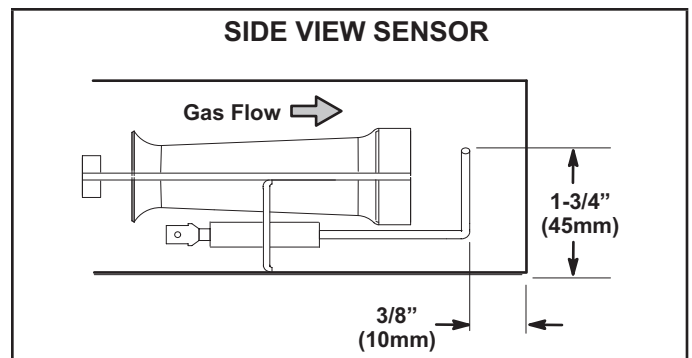

**FIGURE 12**

## 10-Flame Sensor (Figure 13)

A flame sensor is located under the right most side burner. The sensor is mounted through a hole in the burner support and the tip protrudes into the flame envelope of the right most burner. The sensor assembly is fastened to burner supports and can be removed for service without removing any part of the burners.

When flame is sensed by the flame sensor (indicated by microamp signal through the flame) sparking stops immediately or after the eight second trial for ignition. During operation, flame is sensed by current passed along the ground electrode (located on the spark electrode), through the flame and into the sensing electrode. The ignition control allows the gas valve to stay open as long as a flame signal (current passed through the flame) is sensed.



**FIGURE 13**

11-Burner Control A3

TABLE 4

## ⚠ WARNING

Shock hazard. Spark related components contain high voltage which can cause personal injury or death. Disconnect power before servicing. Control is not field repairable. Unsafe operation will result. If control is inoperable, simply replace the entire control.

| LED Flashes       | Indicates  |
|-------------------|--|
| Slow Flash        | Control ok, no call for heat   |
| Fast Flash        | Control ok, call for heat present.   |
| Steady Off        | Internal control fault or no power   |
| Steady On Failure | Control internal failure   |
| 1 Flash           | Rollout switch open  |
| 2 Flashes         | Limit open or lockout from too many tries during a single heat demand        |
| 3 Flashes         | Pressure switch open with inducer on/ open during 5 minute inducer off time. |
| 4 Flashes         | Ignition lockout from no flame detected or from too many flame losses.       |
| 5 Flashes         | Flame sensed out of sequence   |
| 6 Flashes         | Pressure switch closed with inducer off                                      |
| 7 Flashes         | Gas valve relay failure  |
| 8 Flashes         | Lockout due to too many pressure switch openings during one heat demand      |

The ignition controls are located in the heat section areas below the compressors. The controls are manufactured UTEC. See TABLE 4 for LED codes.

The ignition control provides three main functions: gas valve control, ignition and flame sensing. The unit will usually ignite on the first attempt; however, the ignition attempt sequence provides three trials for ignition before locking out. The lockout time for the control is 5 minutes. After lockout, the ignition control automatically resets and provides three more attempts at ignition. Manual reset after lockout requires breaking and remaking power to the ignition control. See FIGURE 14 for a normal ignition sequence and FIGURE 15 for the ignition attempt sequence with retrials (nominal timings given for simplicity). Specific timings for the ignition controls are shown in FIGURE 16.

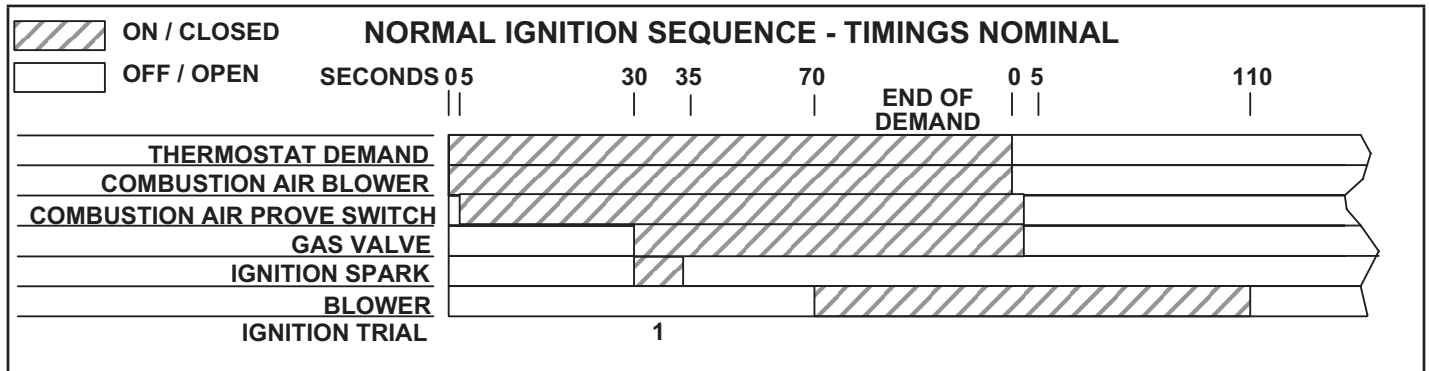

FIGURE 14

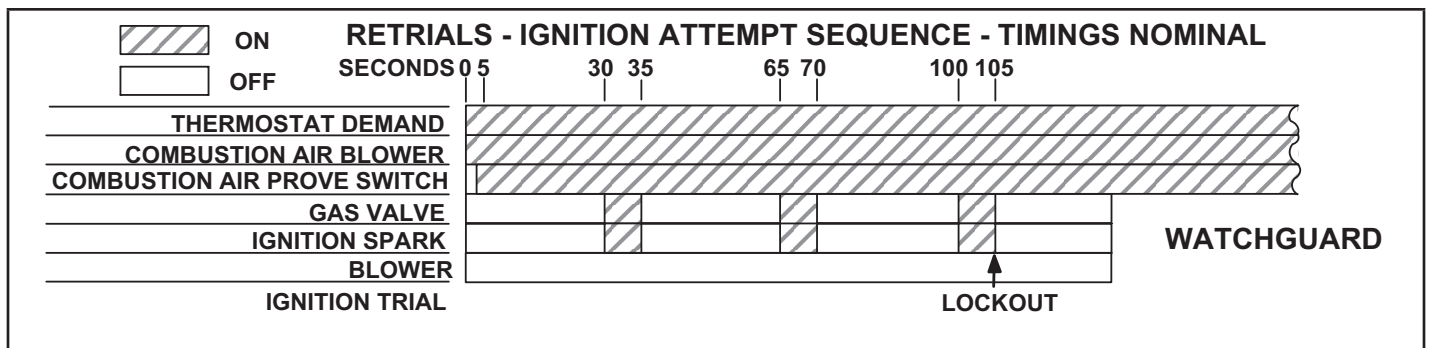
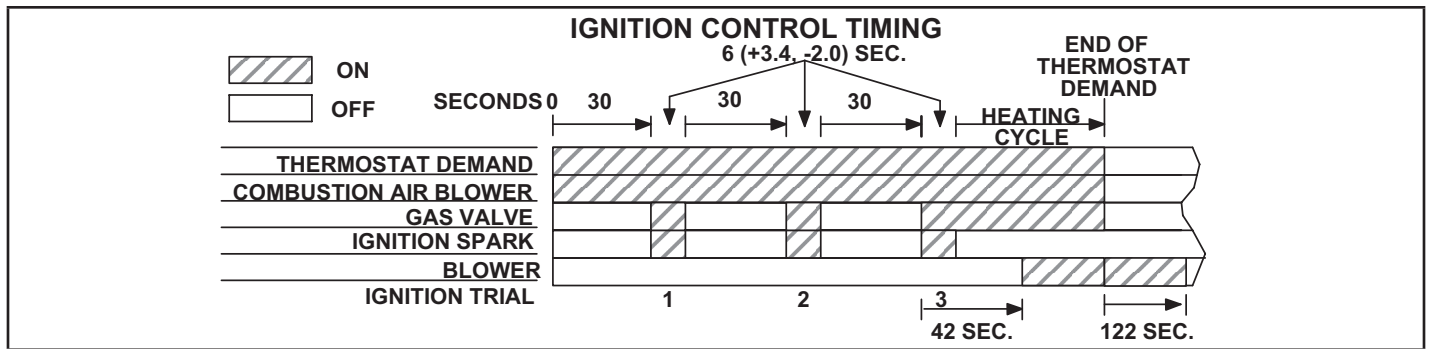

FIGURE 15



**FIGURE 16**

Flame rectification sensing is used on all units. Loss of flame during a heating cycle is indicated by an absence of flame signal (0 microamps). If this happens, the control will immediately restart the ignition sequence and then lock out if ignition is not gained after the third trial. See System Service Checks section for flame current measurement.

The control shuts off gas flow immediately in the event of a power failure. Upon restoration of gas and power, the control will restart the ignition sequence and continue until flame is established or system locks out.

On a heating demand, the ignition control is energized by the A55 Unit Controller. The ignition control then allows 30 to 40 seconds for the combustion air blower to vent exhaust gases from the burners. When the combustion air blower is purging the exhaust gases, the combustion air prove switch is closing proving that the combustion air blower is operating before allowing the ignition control to energize. When the combustion air prove switch is closed and the delay is over, the ignition control activates gas valve, the spark electrode and the flame sensing electrode. Sparking stops immediately after flame is sensed. The combustion air blower continues to operate throughout the heating demand. If the flame fails or if the burners do not ignite, the ignition control will attempt to ignite the burners up to two more times. If ignition cannot be obtained after the third attempt, the control will lock out. The ignition control is not adjustable.

### 12-Balance Point Parameter 526

When outdoor air temperature is above setpoint (35°F ± 5°F default), the unit will operate in heat pump mode. When outdoor air temperature falls below setpoint, the unit will operate in gas heat mode. The balance point setpoint can be adjusted using the following mobile service app menu path:

Go to RTU MENU > SETTINGS > RTU OPTIONS > EDIT PARAMETER = 526 (HP DF BALANCE POINT)

Note - Only stage one is used; stage 2 is not used.

Although the recommended balance point setpoint is 35F, the setpoint can be adjusted. Weigh the comfort / cost benefit when increasing the setpoint.

## II-PLACEMENT AND INSTALLATION

Make sure the unit is installed in accordance with the installation instructions and all applicable codes. See accessories section for conditions requiring use of the optional roof mounting frame (LARMF).

## III-START UP - OPERATION

Refer to start-up directions and refer closely to the unit wiring diagram when servicing. See unit nameplate for minimum circuit ampacity and maximum fuse size.

### A-Preliminary and Seasonal Checks

- 1 - Make sure the unit is installed in accordance with the installation instructions and applicable codes.
- 2 - Inspect all electrical wiring, both field and factory installed for loose connections. Tighten as required. Refer to unit diagram located on inside of unit control box cover.
- 3 - Check to ensure that refrigerant lines are in good condition and do not rub against the cabinet or other refrigerant lines.
- 4 - Check voltage at the disconnect switch. Voltage must be within the range listed on the nameplate. If not, consult the power company and have the voltage corrected before starting the unit.
- 5 - Recheck voltage and amp draw with unit running. If voltage is not within range listed on unit nameplate, stop unit and consult power company. Refer to unit nameplate for maximum rated load amps.
- 6 - Inspect and adjust blower belt (see section on Blower Compartment - Blower Belt Adjustment).

### B-Heat Pump Start Up

**Note** - The outdoor air ambient temperature must be above the heat pump balance point setpoint (35\_F default) to enable heat pump operation. The balance point setpoint can be adjusted using the following mobile service app menu path: Go to RTU MENU > SETTINGS > RTU OPTIONS > EDIT PARAMETER = 526 (HP DF BALANCE POINT)

- 1 - Set thermostat or temperature control device to initiate a first-stage heating demand.

A first-stage heating demand (W1) will energize compressors 1 and 2. All outdoor fans are energized with a W1 demand.

**Note** - L1 and L2 reversing valves are de-energized in the heating mode.

- 2 - An increased heating demand (W2) will energize high gas heat and de-energize heat pump operation.

### C-Gas Heating Start Up

#### FOR YOUR SAFETY READ BEFORE LIGHTING

| <b>⚠ WARNING</b>  |   |
|---|---|
|  | <b>Danger of explosion. Can cause injury or product or property damage. If overheating occurs or if gas supply fails to shut off, shut off the manual gas valve to the appliance before shutting off electrical supply.</b> |

| <b>⚠ WARNING</b>   |   |
|--|---|
|  | <b>Electric shock hazard. Can cause injury or death. Do not use this unit if any part has been under water. Immediately call a qualified service technician to inspect the unit and to replace any part of the control system and any gas control which has been under water.</b> |

| <b>⚠ WARNING</b>  |  |
|---|--|
|  | <b>Electric shock hazard. Can cause injury or death. Before attempting to perform any service or maintenance, turn the electrical power to unit OFF at disconnect switch(es). Unit may have multiple power supplies.</b> |

| <b>⚠ WARNING</b>  |  |
|---|--|
| <b>SMOKE POTENTIAL</b>  |  |
| <b>The heat exchanger in this unit could be a source of smoke on initial firing. Take precautions with respect to building occupants and property. Vent initial supply air outside when possible.</b> |  |

BEFORE LIGHTING smell all around the appliance area for gas. Be sure to smell next to the floor because some gas is heavier than air and will settle on the floor.

Use only your hand to push in or turn the gas control knob. Never use tools. If the knob will not push in or turn by hand, do not try to repair it, call a qualified service technician. Force or attempted repair may result in a fire or explosion.

| <b>⚠ WARNING</b>  |   |
|---|---|
|  | <b>Danger of explosion. Can cause injury or death. Do not attempt to light manually. Unit has a direct spark ignition system.</b> |

This unit is equipped with an automatic spark ignition system. There is no pilot. In case of a safety shutdown, move thermostat switch to **OFF** and return the thermostat switch to **HEAT** to reset ignition control.

#### Placing Unit In Operation

| <b>⚠ WARNING</b>  |  |
|---|--|
|  | <b>Danger of explosion and fire. Can cause injury or product or property damage. You must follow these instructions exactly.</b> |

#### Gas Valve Operation for White Rodgers 36H54 FIGURE 17

- 1 - Set HP balance point thermostat setpoint above the outdoor ambient temperature to disable heat pump operation.
- 2 - Turn off all electrical power to appliance.
- 3 - This appliance is equipped with an ignition device which automatically lights the burner. Do not try to light the burner by hand.
- 4 - Open or remove the heat section access panel.
- 5 - Turn gas valve switch to “**OFF**”. Do not force.
- 6 - Wait five (5) minutes to clear out any gas. If you then smell gas, **STOP!** Immediately call your gas supplier from a neighbor’s phone. Follow the gas supplier’s instructions. If you do not smell gas, go to the next step.
- 7 - Turn gas valve switch to “**ON**”. Do not force.
- 8 - Close or replace the heat section access panel.
- 9 - Turn on all electrical power to appliance.
- 10 - Set thermostat to desired setting.
- 11 - The combustion air inducer will start. The burners will light within 40 seconds.
- 12 - If the appliance does not light the first time (gas line not fully purged), it will attempt two more ignitions before locking out.
- 13 - If lockout occurs, repeat steps 1 through 10.
- 14 - If the appliance will not operate, follow the instructions “Turning Off Gas to Appliance” and call your service technician or gas supplier.

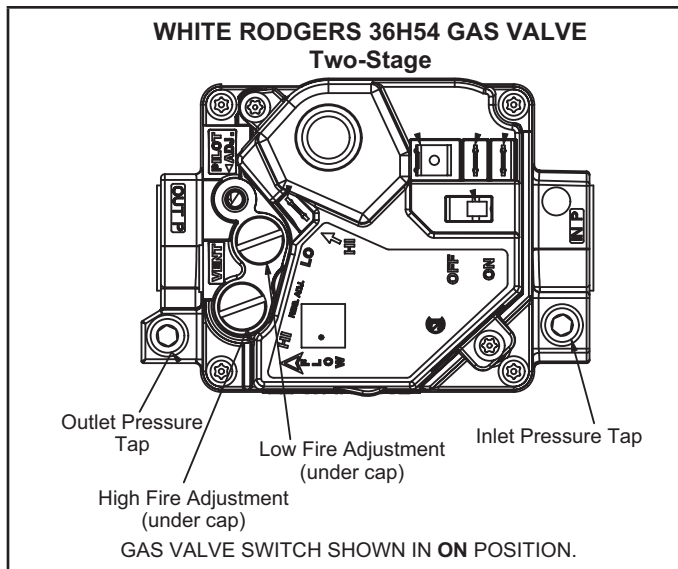

**FIGURE 17**

### Turning Off Gas to Appliance

- 1 - If using an electromechanical thermostat, set to the lowest setting.
- 2 - Before performing any service, turn off all electrical power to the appliance.
- 3 - Open or remove the heat section access panel.
- 4 - Turn gas valve switch to "OFF". Do not force.

### D-Safety or Emergency Shutdown

Turn off power to the unit. Close manual and main gas valves.

**⚠ WARNING**

**Danger of explosion. Can cause injury or death. Do not attempt to light manually. Unit has a direct spark ignition system.**

### E-Cooling Start Up

**⚠ IMPORTANT**

**If unit is equipped with a crankcase heater. Make sure heater is energized 24 hours before unit start-up to prevent compressor damage as a result of slugging.**

- 1 - Initiate full load cooling operation using the following mobile service app menu path:

*RTU MENU > SERVICE > COMPONENT TEST > COOLING > COOLING STAGE 3*

- 2 - Refer to Cooling Operation section for cooling start-up.
- 3 - Units have two refrigerant circuits. See FIGURE 18 or FIGURE 19.
- 4 - Each refrigerant circuit is charged with R454B refrigerant. See unit rating plate for correct amount of charge.
- 5 - Refer to Refrigerant Check and Charge section for proper method to check refrigerant charge.

### Three Phase Scroll Compressor Voltage Phasing

Three phase power supplied to the unit disconnect switch must be phased sequentially to ensure the scroll compressor and indoor blower rotate in the correct direction. Compressor and blower are wired in phase at the factory. Power wires are color-coded as follows: line 1-red, line 2-yellow, line 3-blue.

- 1 - Observe suction and discharge pressures on unit start-up.
- 2 - Suction pressure must drop, discharge pressure must rise.

If pressure differential is not observed:

- 3 - Disconnect all remote electrical power supplies.
- 4 - Reverse any two field-installed wires connected to the power entry component, disconnect switch (S48), circuit breaker (CB10), or terminal block (TB2).
- 5 - Make sure the connections are tight. Discharge and suction pressures should operate at their normal start-up ranges.

### F-Safety or Emergency Shutdown

Turn off power to the unit. Close manual and main gas valves.

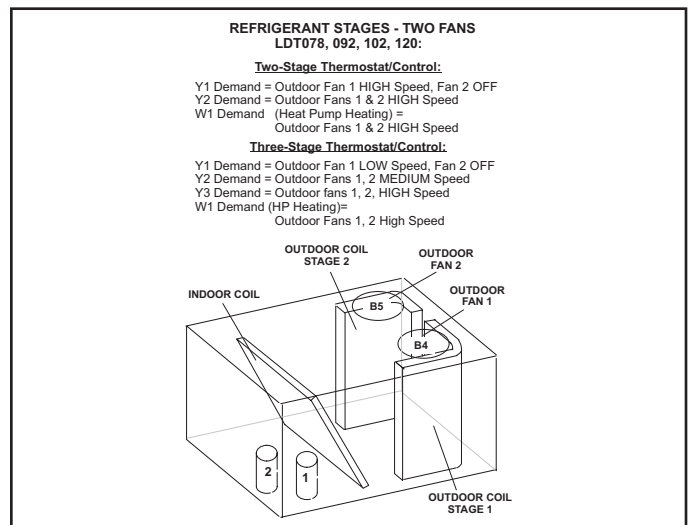

**FIGURE 18**

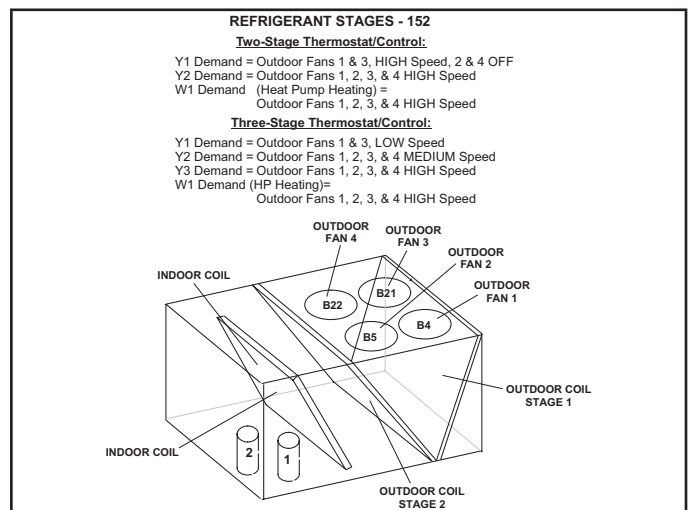

**FIGURE 19**

## IV- SYSTEMS SERVICE CHECKS

### **WARNING**

**Refrigerant can be harmful if it is inhaled. Refrigerant must be used and recovered responsibly.**

**Failure to follow this warning may result in personal injury or death.**

#### A-Charging

**WARNING-Do not exceed nameplate charge under any condition.**

This unit is factory charged and should require no further adjustment. If the system requires additional refrigerant, reclaim the charge, evacuate the system, and add required nameplate charge.

| Refrigerant Charge R-454B |         |                      |                     |
|---------------------------|---------|----------------------|---------------------|
| Unit                      | Stage   | M <sub>c</sub> (lbs) | M <sub>c</sub> (kg) |
| LDT 078                   | Stage 1 | 11.50                | 5.22                |
|                           | Stage 2 | 11.00                | 4.99                |
| LDT 092                   | Stage 1 | 11.00                | 4.99                |
|                           | Stage 2 | 11.25                | 5.10                |
| LDT 102                   | Stage 1 | 10.85                | 4.92                |
|                           | Stage 2 | 11.25                | 5.10                |
| LDT 120                   | Stage 1 | 10.69                | 4.85                |
|                           | Stage 2 | 10.63                | 4.82                |
| LDT 152                   | Stage 1 | 15.00                | 6.80                |
|                           | Stage 2 | 12.75                | 5.78                |

When breaking into the refrigerant circuit to make repairs – or for any other purpose – conventional procedures shall be used. However, for flammable refrigerants it is important that best practice be followed and, since flammability is a consideration, the following procedure shall be adhered to:

- Safely remove refrigerant following local and national regulations,
- Evacuate the circuit,
- Purge the circuit with inert gas,
- Evacuate,
- Purge with inert gas,
- Open the circuit

The refrigerant charge shall be recovered into the correct recovery cylinders if venting is not allowed by local and national codes. For appliances containing flammable refrigerants, the system shall be purged with oxygen-free nitrogen to render the appliance safe for flammable refrigerants. This process might need to be repeated several times. Compressed air or oxygen shall not be used for purging refrigerant systems. Refrigerant purging shall be achieved by breaking the vacuum in the system with oxygen-free nitrogen and continuing to fill until the

working pressure is achieved, then venting to atmosphere, and finally pulling down to a vacuum. This process shall be repeated until no refrigerant is within the system. When the final oxygen-free nitrogen charge is used, the system shall be vented down to atmospheric pressure to enable work to take place. Ensure that the outlet for the vacuum pump is not close to any potential ignition sources and that ventilation is available.

In addition to conventional charging procedures, the following requirements shall be followed.

- Ensure that contamination of different refrigerants does not occur when using charging equipment. Hoses or lines shall be as short as possible to minimize the amount of refrigerant contained in them.
- Cylinders shall be kept in an appropriate position according to the instructions.
- Ensure that the refrigerating unit is earthed prior to charging the system with refrigerant.
  - Label the system when charging is complete (if not already).
  - Extreme care shall be taken not to overfill the refrigerating unit.

Prior to recharging the system, it shall be pressure-tested with the appropriate purging gas. The system shall be leak-tested on completion of charging but prior to commissioning. A follow up leak test shall be carried out prior to leaving the site.

- When removing refrigerant from a system, either for servicing or decommissioning, it is recommended good practice that all refrigerants are removed safely. When transferring refrigerant into cylinders, ensure that only appropriate refrigerant recovery cylinders are employed. Ensure that the correct number of cylinders for holding the total system charge is available. All cylinders to be used are designated for the recovered refrigerant and labelled for that refrigerant (i. e. special cylinders for the recovery of refrigerant). Cylinders shall be complete with pressure-relief valve and associated shut-off valves in good working order. Empty recovery cylinders are evacuated and, if possible, cooled before recovery occurs.
- The recovery equipment shall be in good working order with a set of instructions concerning the equipment that is at hand and shall be suitable for the recovery of all appropriate refrigerants including, when applicable, flammable refrigerants. In addition, a set of calibrated weighing scales shall be available and in good working order. Hoses shall be complete with leak-free disconnect couplings and in good condition. Before using the recovery machine, check that it is in satisfactory working order, has been properly maintained and that any associated electrical components are sealed to prevent

ignition in the event of a refrigerant release. Consult manufacturer if in doubt.

- The recovered refrigerant shall be returned to the refrigerant supplier in the correct recovery cylinder, and the relevant waste transfer note arranged. Do not mix refrigerants in recovery units and especially not in cylinders.
- If compressors or compressor oils are to be removed, ensure that they have been evacuated to an acceptable level to make certain that flammable refrigerant does not remain within the lubricant. The evacuation process shall be carried out prior to returning the compressor to the suppliers. Only electric heating to the compressor body shall be employed to accelerate this process. When oil is drained from a system, it shall be carried out safely.

**NOTE** - System charging is not recommended below 60F (15C). In temperatures below 60F (15C), the charge must be weighed into the system.

If weighing facilities are not available, or to check the charge, use the following procedure:

**IMPORTANT - Charge unit in standard cooling mode.**

- 1 - Attach gauge manifolds to discharge and suction lines. With the economizer disabled, operate the unit in cooling mode at high speed using the following mobile service app menu path:

SERVICE > COMPONENT TEST > COOLING > COOLING STAGE 3

- 2 - Use a thermometer to accurately measure the outdoor ambient temperature.
- 3 - Apply the outdoor temperature to TABLE 5 through TABLE 9 to determine normal operating pressures.
- 4 - Pressures are listed for sea level applications at 80F dry bulb and 67F wet bulb return air.
- 5 - Compare the normal operating pressures to the pressures obtained from the gauges. Minor variations in these pressures may be expected due to differences in installations. Significant differences could mean that the system is not properly charged or that a problem exists with some component in the system. Correct any system problems before proceeding.
- 6 - If discharge pressure is high, remove refrigerant from the system. If discharge pressure is low, add refrigerant to the system.
  - Add or remove charge in increments.
  - Allow the system to stabilize each time refrigerant is added or removed.
- 7 - Use the following approach method along with the normal operating pressures to confirm readings

**TABLE 5**

LDT078 - 581257-01

| OD Coil Entering Air Temp | Circuit 1        |                |                 | Circuit 2        |                |                  |
|---------------------------|------------------|----------------|-----------------|------------------|----------------|------------------|
|                           | Disch. ± 10 psig | Suct. ± 5 psig | Appr. Temp ±1°F | Disch. ± 10 psig | Suct. ± 5 psig | Appr. Temp ± 1°F |
| 65°F                      | 238              | 127            | 2               | 220              | 131            | 5                |
| 75°F                      | 274              | 130            | 2               | 254              | 135            | 3                |
| 85°F                      | 314              | 131            | 2               | 292              | 137            | 1                |
| 95°F                      | 357              | 132            | 2               | 333              | 138            | 1                |
| 100°F                     | 404              | 133            | 3               | 376              | 140            | 1                |
| 115°F                     | 452              | 136            | 2               | 431              | 143            | 2                |

**TABLE 6**

LDT092 - 581258-01

| OD Coil Entering Air Temp | Circuit 1        |                |                 | Circuit 2        |                |                  |
|---------------------------|------------------|----------------|-----------------|------------------|----------------|------------------|
|                           | Disch. ± 10 psig | Suct. ± 5 psig | Appr. Temp ±1°F | Disch. ± 10 psig | Suct. ± 5 psig | Appr. Temp ± 1°F |
| 65°F                      | 232              | 120            | 4               | 235              | 125            | 7                |
| 75°F                      | 269              | 125            | 2               | 271              | 129            | 6                |
| 85°F                      | 308              | 127            | 2               | 311              | 131            | 3                |
| 95°F                      | 352              | 130            | 3               | 356              | 133            | 4                |
| 100°F                     | 398              | 132            | 3               | 401              | 136            | 4                |
| 115°F                     | 450              | 134            | 4               | 453              | 139            | 5                |

**TABLE 7**

LDT102 - 581259-01

| OD Coil Entering Air Temp | Circuit 1        |                |                 | Circuit 2        |                |                  |
|---------------------------|------------------|----------------|-----------------|------------------|----------------|------------------|
|                           | Disch. ± 10 psig | Suct. ± 5 psig | Appr. Temp ±1°F | Disch. ± 10 psig | Suct. ± 5 psig | Appr. Temp ± 1°F |
| 65°F                      | 233              | 122            | 5               | 246              | 121            | 8                |
| 75°F                      | 271              | 127            | 3               | 282              | 125            | 8                |
| 85°F                      | 309              | 127            | 3               | 323              | 127            | 4                |
| 95°F                      | 351              | 129            | 3               | 365              | 129            | 4                |
| 100°F                     | 398              | 130            | 3               | 413              | 132            | 5                |
| 115°F                     | 447              | 132            | 4               | 464              | 135            | 6                |

**TABLE 8**

LDT120 - 581260-01

| OD Coil Entering Air Temp | Circuit 1        |                |                 | Circuit 2        |                |                  |
|---------------------------|------------------|----------------|-----------------|------------------|----------------|------------------|
|                           | Disch. ± 10 psig | Suct. ± 5 psig | Appr. Temp ±1°F | Disch. ± 10 psig | Suct. ± 5 psig | Appr. Temp ± 1°F |
| 65°F                      | 247.2            | 121.2          | 9               | 255.6            | 122            | 12               |
| 75°F                      | 284.3            | 124.7          | 8               | 293.2            | 125.2          | 8                |
| 85°F                      | 325.1            | 129.6          | 6               | 335.1            | 127.5          | 8                |
| 95°F                      | 368.1            | 132.7          | 6               | 376.4            | 130.6          | 7                |
| 100°F                     | 416              | 135.5          | 7               | 426.6            | 134.4          | 8                |
| 115°F                     | 464.2            | 137.9          | 8               | 473.1            | 137.2          | 9                |

**TABLE 9**  
LDT152 - 581261-01

| OD Coil Entering Air Temp | Circuit 1        |                |                 | Circuit 2        |                |                  |
|---------------------------|------------------|----------------|-----------------|------------------|----------------|------------------|
|                           | Disch. ± 10 psig | Suct. ± 5 psig | Appr. Temp ±1°F | Disch. ± 10 psig | Suct. ± 5 psig | Appr. Temp ± 1°F |
| 65°F                      | 239              | 122            | 9               | 258              | 122            | 10               |
| 75°F                      | 276              | 125            | 8               | 296              | 124            | 4                |
| 85°F                      | 318              | 127            | 2               | 336              | 126            | 4                |
| 95°F                      | 363              | 132            | 3               | 389              | 129            | 5                |
| 100°F                     | 412              | 133            | 4               | 425              | 129            | 5                |
| 115°F                     | 467              | 135            | 4               | 475              | 131            | 5                |

**B-Charging - Approach Method**

- 1 - Attach gauge manifolds to discharge and suction lines. With the economizer disabled, operate the unit in cooling mode at high speed using the following mobile service app menu path:  
RTU MENU > SERVICE > COMPONENT TEST > COOLING > COOL STAGE 3
- 2 - Using the same thermometer, compare liquid temperature to outdoor ambient temperature.
- 3 - Approach Temperature = Liquid temperature (at liquid line close to pressure tap) minus ambient temperature.
- 4 - Refer to TABLE 5 through TABLE 9 for approach temperatures. An approach temperature greater than value shown indicates an undercharge. An approach temperature less than value shown indicates an overcharge.
- 5 - The approach method is not valid for grossly over or undercharged systems. Use TABLE 5 through TABLE 9 as a guide for typical operating pressures

**C-Heating System Service Checks**

All LDT units are ETL/CSA design certified without modification.

Before checking piping, check with gas company or authorities having jurisdiction for local code requirements. Refer to the LDT Installation instruction for more information.

**1-Gas Piping**

Gas supply piping must not allow more than 0.5"W.C. (124.3 Pa) drop in pressure between the gas meter and the unit. Supply gas pipe must not be smaller than the unit gas connection. Refer to installation instructions for details.

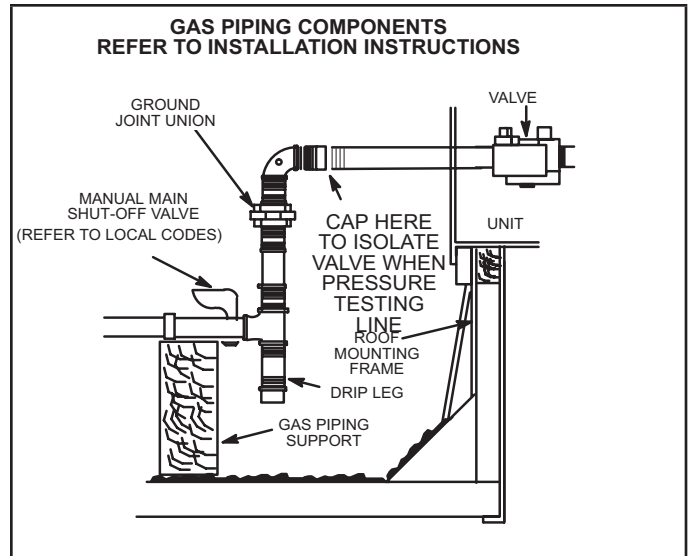

**FIGURE 20**

**2-Testing Gas Piping**

**NOTE-**In case emergency shutdown is required, turn off the main manual shut-off valve and disconnect the main power to the unit. These controls should be properly labeled by the installer.

When pressure testing gas lines, the gas valve must be disconnected and isolated. **Gas valves can be damaged if subjected to more than 0.5 psig [14"W.C. (3481 Pa)].** See FIGURE 20.

When checking piping connection for gas leaks, use the preferred means. Common kitchen detergents can cause harmful corrosion on various metals used in gas piping.

The use of specialty Gas Leak Detector is strongly recommended.

**Do not use matches, candles, flame or any other source of ignition to check for gas leaks.**

**3-Testing Gas Supply Pressure**

When testing gas supply pressure, connect test gauge to the inlet pressure tap located on unit gas valve GV1. Test supply gas pressure with unit firing at maximum rate (both stages energized). Make sure the reading falls within the range of the following values.

Low pressure may result in erratic operation or "underfire." High pressure can result in permanent damage to the gas valve or "overfire."

For natural gas units, operating pressure at the unit gas connection must be between 4.7"W.C. and 10.5"W.C. (1168 Pa and 2610 Pa). For L.P. gas units, operating pressure at the unit gas connection must be between 10.8"W.C. and 13.5"W.C. (2685.3 Pa and 3356.7 Pa).

On multiple unit installations, each unit should be checked separately while operating at maximum rate, beginning with the one closest to the supply gas main and progressing to the one furthest from the main. Multiple units should also be tested with and without the other units operating. Supply pressure must fall within the range listed in the previous paragraph.

#### 4-Check and Adjust Manifold Pressure

After line pressure has been checked and adjusted, check manifold pressure. Move test gauge to the outlet pressure tap located on unit gas valve GV1. See FIGURE 17 for location of pressure tap on the gas valve.

The manifold pressure is factory set and should not require adjustment. If manifold pressure is incorrect and no other source of improper manifold pressure can be found, the valve must be replaced. See FIGURE 17 for location of gas valve (manifold pressure) adjustment screw.

All gas valves are factory regulated. The gas valve should completely and immediately cycle off in the event of gas or power failure. The manual shut-off knob can be used to immediately shut off gas supply.

### CAUTION

**For safety, connect a shut-off valve between the manometer and the gas tap to permit shut off of gas pressure to the manometer.**

#### Manifold Adjustment Procedure

- 1 - Connect test gauge to the outlet pressure tap on the gas valve. Start the unit (call for second stage heat) and allow five minutes for the unit to reach steady state.
- 2 - While waiting for the unit to stabilize, notice the flame. The flame should be stable without flashback and should not lift from the burner heads. Natural gas should burn basically blue with some clear streaks. L.P. gas should burn mostly blue with some clear yellow streaks.
- 3 - After allowing the unit to stabilize for five minutes, record the manifold pressure and compare to the values given in table 7.

### CAUTION

**Disconnect heating demand as soon as an accurate reading has been obtained.**

#### 5-Proper Gas Flow

Furnace should operate at least 5 minutes before checking gas flow. Determine time in seconds for two revolutions of gas through the meter. (Two revolutions assures a more accurate time.) Divide by two and compare to time in TABLE 10. Seconds in TABLE 10 are based on a 1 cu.ft. dial and gas value of 1000 btu's for natural and 2500 btu's for LP. Adjust manifold pressure on gas valve to match time needed.

**NOTE - To obtain accurate reading, shut off all other gas appliances connected to meter.**

**TABLE 10**

| Unit in Btu's | Seconds for Natural | Seconds for Propane |
|---------------|---------------------|---------------------|
| 130,000       | 28                  | 69                  |
| 180,000       | 20                  | 50                  |
| 240,000       | 15                  | 38                  |

**NOTE - Table assumes standard temperature (60°F), pressure (30in. Hg.), and fuel heating values (Btu/Ht.3). Apply pressure corrections in altitudes above 2000 ft.**

#### 6-Heat Exchanger

To Access or Remove Heat Exchanger From Unit:

- 1 - Turn off gas and electric power.
- 2 - Remove access panel(s) and unit center mullion.
- 3 - Remove gas valve, manifold assembly and burners.
- 4 - Remove combustion air inducer and flue box cover. Pay careful attention to the order in which gaskets and orifice are removed.
- 5 - Support heat exchanger (to prevent it from falling when final screws are removed.)
- 6 - Remove screws supporting heat exchanger.
- 7 - To install heat exchanger, reverse procedure. Be sure to secure all wires and check plumbing and burner plate for airtight seal. Screws must be torqued to 35 in.-lbs. to ensure proper operation.

#### 7-Flame Sensing

Flame current is an electrical current which passes from the ignition control through the sensor electrode during unit operation. The current passes from the sensor through the flame to the ground electrode (located on the flame electrode) to complete a safety circuit. The electrodes should be located so the tips are at least 1/2" (12.7 mm) inside the flame envelope. Do not bend electrodes. To measure flame current, follow the procedure on the following page:

**NOTE-Electrodes are not field adjustable. Any alterations to the electrode may create a hazardous condition that can cause property or personal injury.**

- 1 - Disconnect power to unit.
- 2 - Remove lead from sensing electrode and install a 0-50DC microamp meter in series between the sensing electrode and the sensing lead.
- 3 - Reconnect power and adjust thermostat for heating demand.
- 4 - When flame is established, microamp reading should be 0.5 to 1.0. Do not bend electrodes. Drop out signal is .09 or less.
- 5 - Disconnect power to unit before disconnecting meter. Make sure sensor wire is securely reconnected before reconnecting power to unit.

**NOTE-If the meter scale reads 0, the leads are reversed. Disconnect power and reconnect leads for proper polarity.**

#### D-Cooling System Service Checks

LDT units are factory charged and require no further adjustment; however, charge should be checked periodically using the approach method. The approach method compares actual liquid temperature with the outdoor ambient temperature. See Charging - Approach Method section.

**NOTE-When unit is properly charged discharge line pressures should approximate those in TABLE 5 through TABLE 9.**

## V-MAINTENANCE

The unit should be inspected once a year by a qualified service technician.

|   |   |
|---|---|
| <b>⚠ WARNING</b>  |   |
|  | Electric shock hazard. Can cause injury or death. Before attempting to perform any service or maintenance, turn the electrical power to unit OFF at disconnect switch(es). Unit may have multiple power supplies. |

|  |  |
|--|--|
| <b>⚠ IMPORTANT</b>   |  |
| Label all wires prior to disconnection when servicing controls. Wiring errors can cause improper and dangerous operation. Verify proper operation after servicing. |  |

|   |  |
|---|--|
| <b>⚠ WARNING</b>  |  |
| Any service personnel installing, decommissioning, or performing maintenance on the unit must be properly trained with A2L refrigerants |  |

### Prior to beginning work on systems containing refrigerant to ensure the risk of ignition is minimized:

- All work shall be undertaken under a controlled procedure so as to minimize the risk of a flammable gas or vapor being present while the work is being performed.
- The area shall be checked with an appropriate refrigerant detector prior to and during work, to ensure the technician is aware of potentially toxic or flammable atmospheres. Ensure that the leak detection equipment being used is suitable for use with all applicable refrigerants, i. e. non-sparking, adequately sealed or intrinsically safe.
- If any hot work is to be conducted on the refrigerating equipment or any associated parts, the appropriate fire extinguishing equipment shall be available to hand. Have a dry powder or CO2 fire extinguisher adjacent to the charging area.
- No person carrying out work in relation to a refrigerating system which involves exposing any pipe work shall use any sources of ignition in such a manner that it may lead to the risk of fire or explosion. All possible ignition sources, including cigarette smoking, should be kept sufficiently far away from the site of installation, repairing, removing and disposal, during which refrigerant can possibly be released to the surrounding space. Prior to work taking place, the area around the equipment is to be surveyed to make sure that there are no flammable hazards or ignition risks. "No Smoking" signs shall be displayed.

- Ensure that the area is in the open or that it is adequately ventilated before breaking into the system or conducting any hot work.

A degree of ventilation shall continue during the period that the work is carried out. The ventilation should safely disperse any released refrigerant and preferably expel it externally into the atmosphere.

- Where electrical components are being changed, service technicians shall be fit for the purpose and to the correct specification. At all times the manufacturer's maintenance and service guidelines shall be followed. If in doubt, consult the manufacturer's technical department for assistance. The following checks shall be applied to installations using flammable refrigerants as applicable:

- 1 - The actual refrigerant charge is in accordance with the room size within which the refrigerant containing parts are installed.
- 2 - The ventilation machinery and outlets are operating adequately and are not obstructed.
- 3 - If an indirect refrigerating circuit is being used, the secondary circuit shall be checked for the presence of refrigerant.
- 4 - Markings on the equipment should be visible and legible. Markings and signs that are illegible shall be corrected.
- 5 - Refrigerating pipes or components are installed in a position where they are unlikely to be exposed to any substance which may corrode refrigerant containing components, unless the components are constructed of materials which are inherently resistant to being corroded or are suitably protected against being so corroded. For systems containing refrigerant all repair and maintenance to electrical components shall include initial safety checks and component inspection procedures such as that capacitors are discharged in a safe manner to avoid possibility of sparking, that no live electrical components and wiring are exposed while charging, recovering, or purging the system, and that there is continuity of earth bonding. If a fault exists that could compromise safety, then no electrical supply shall be connected to the circuit until it is satisfactorily dealt with. If the fault cannot be corrected immediately but it is necessary to continue operation, an adequate temporary solution shall be used that is reported to the owner of the equipment, so all parties are advised.

**NOTE** - Sealed electrical components shall be replaced, not repaired.

**NOTE** - Intrinsically safe components must be replaced, not repaired.

- Under no circumstances shall potential sources of ignition be used in the searching for or detection of refrigerant leaks. A halide torch (or any other detector using a naked flame) shall not be used. Electronic leak detectors may be used to detect refrigerant leaks but, in the case of flammable refrigerants, the sensitivity may not be adequate, or may need re-calibration. (Detection equipment shall be calibrated in a refrigerant-free area.) Ensure that the detector is not a potential source of ignition and is suitable for the refrigerant used. Leak detection equipment shall be set at a percentage of the LFL of the refrigerant and shall be calibrated to the refrigerant employed, and the appropriate percentage of gas (25 % maximum) is confirmed. Leak detection fluids are also suitable for use with most refrigerants but the use of detergents containing chlorine shall be avoided as the chlorine may react with the refrigerant and corrode the copper pipe-work. If a leak is suspected, all naked flames shall be removed/extinguished. If a leakage of refrigerant is found which requires brazing, all of the refrigerant shall be recovered from the system, or isolated (by means of shut off valves) in a part of the system remote from the leak.
- When breaking into the refrigerant circuit to make repairs – or for any other purpose – conventional procedures shall be used. However, for flammable refrigerants it is important that best practice be followed, since flammability is a consideration. The following procedure shall be adhered to:
  - Safely remove refrigerant following local and national regulations,
  - Evacuate the circuit,
  - Purge the circuit with inert gas,
  - Evacuate,
  - Purge with inert gas,
  - Open the circuit.
- The refrigerant charge shall be recovered into the correct recovery cylinders if venting is not allowed by local and national codes. For appliances containing flammable refrigerants, the system shall be purged with oxygen-free nitrogen to render the appliance safe for flammable refrigerants. This process might need to be repeated several times. Compressed air or oxygen shall not be used for purging refrigerant systems. Refrigerant purging shall be achieved by breaking the vacuum in the system with oxygen-free nitrogen and continuing to fill until the working pressure is achieved, then venting to atmosphere, and finally pulling down to a vacuum. This process shall be repeated until no refrigerant is within the system. When the final oxygen-free nitrogen charge is used, the system shall be vented down to atmospheric pressure to enable work to take place. Ensure that the outlet for the vacuum pump is not close to any potential ignition sources and that ventilation is available.

### A-Lubrication

All motors are lubricated at the factory. No further lubrication is required.

### B-Filters

Units are equipped with four 20 X 25 X 2” filters. Filters should be checked monthly and replaced when necessary with filters of like kind and size. Take note of air flow direction marking on filter frame when reinstalling filters. See FIGURE 21.

**NOTE-**Filters must be U.L.C. certified or equivalent for use in Canada.

### C-Supply Air Blower Wheel

Annually inspect supply air blower wheel for accumulated dirt or dust. Turn off power before attempting to remove access panel or to clean blower wheel.

### D-Indoor Coil

Inspect and clean coil at beginning of each cooling and heating season. Clean using mild detergent or commercial coil cleanser. Flush coil and condensate drain with water taking care not to get insulation, filters and return air ducts wet.

### E-Outdoor Coil

Clean outdoor coil annually with detergent or commercial coil cleaner and inspect monthly during the cooling season. For LDT078-120H Models, outdoor coils are made of two formed slabs. Dirt and debris may become trapped between the slabs. To clean between slabs, carefully separate coil slabs (no more than 4 inches) and wash them thoroughly. See FIGURE 26. Flush coils with water following cleaning. Check connecting lines and coil for evidence of oil and refrigerant leaks.

### F-Filter Drier

The unit is equipped with a bi-flow filter drier. If replacement is necessary, order another of like design.

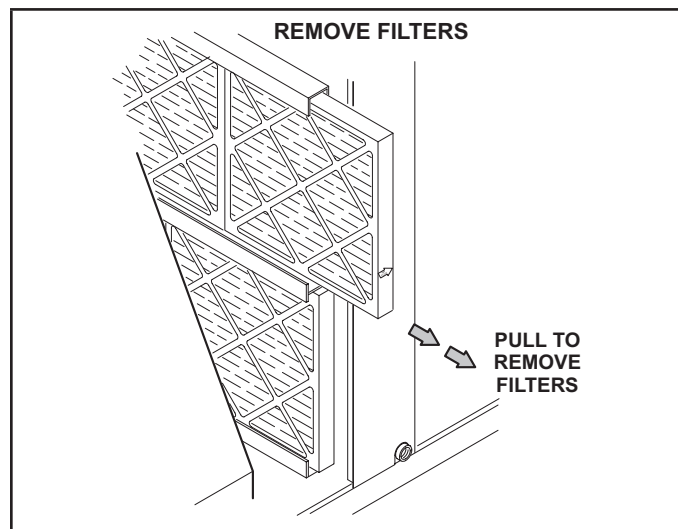
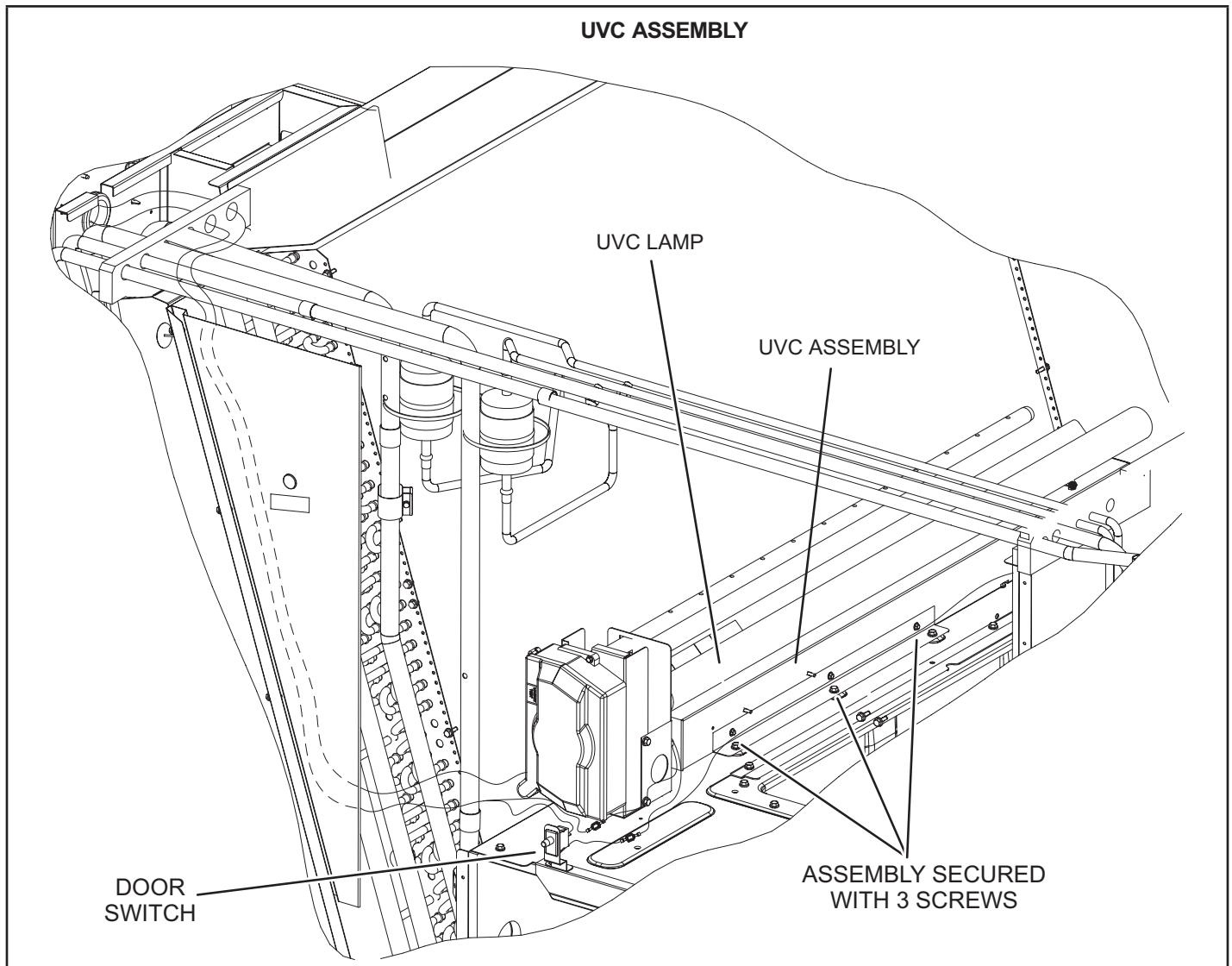

FIGURE 21

## VI-ACCESSORIES

The accessories section describes the application of most of the optional accessories which can be factory or field installed to the LDT units.



**FIGURE 22**

**K-UVC Light**

When field-installed, use only UVC Light Kit assembly 106882-01 (21A93) with this appliance.

**Factory-Installed UVC Light**

When the UVC light is factory installed, the lamp is shipped in a foam sleeve. The lamp is attached to the UVC light assembly on the blower deck. See FIGURE 22. Remove the lamp and install into the UVC light assembly as shown in steps 2 through 11.

**Annual Lamp Replacement**

**⚠ WARNING**

Personal Burn Hazard.

Personal injury may result from hot lamps. During replacement, allow lamp to cool for 10 minutes before removing lamp from fixture.

The lamp should be replaced every 12 months, as UVC energy production diminishes over time.

- 1 - Obtain replacement lamp 101087-01 for your germicidal light model.

- 2 - Disconnect power to the rooftop unit before servicing the UVC kit.
- 3 - Open the blower access door.
- 4 - Remove the screw in wire tie from the UVC assembly and disconnect the 4-pin connector from the lamp end.
- 5 - Remove and retain the (3) screws securing the UVC assembly. Carefully slide the complete UVC assembly out through the blower access door. See FIGURE 22.
- 6 - Allow 10 minutes before touching the lamps. Then, carefully remove the old lamp from the lamp holder clips.
- 7 - Wear cotton gloves or use a cotton cloth when handling the new lamp. Place the new lamp in the holder clips of the UVC assembly. Verify that the lamp flange at the connector end is sandwiched between the lamp holder clip and the sheet-metal end stop (see FIGURE 23).

- 8 - Carefully place the UVC assembly on the blower deck. Line up the mounting holes on the UVC assembly with the mounting holes on the blower deck. See FIGURE 22. Use the retained screws provided to attach the UVC assembly in place.
- 9 - Close the blower access door.
- 10 - Reconnect power to the rooftop unit.
- 11 - Open the filter access door and look through the view port in the triangular sheet-metal panel to verify that the UVC light is on.

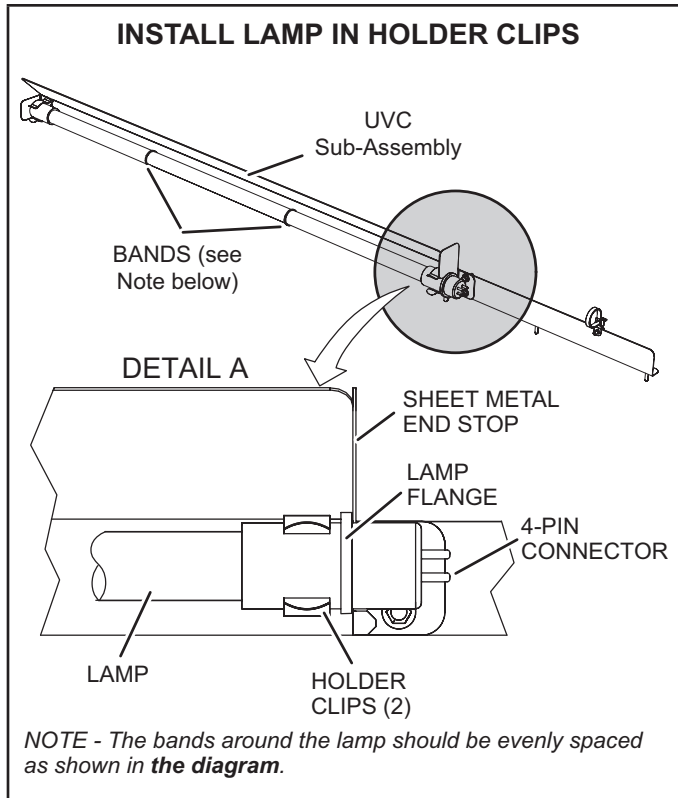

**FIGURE 23**

If UVC lamp does not come on:

- 1 - Check Power Wiring: Disconnect 1/4" QC (quick connects) of the UVC cable near the UVC assembly. With Power ON, use multimeter to test 110-230V at the 1/4" QC quick connects from the control panel.
- 2 - Check Lamp: Carefully remove the UVC assembly out of the rooftop unit. Use multimeter to test for continuity across each pair of pins at each end of the lamp.
- 3 - Check Lamp Installation: Make sure that lamp's pins snap properly into the lamp holder.

**LED(s) not illuminated**

*Power status LED not lit*—Check that the lamp unit is connected to the proper power source and is wired correctly.

*Lamp status LED(s) not lit*—

- 1 - Check that lamp 4-pin connectors are properly engaged.

- 2 - Ohm-check across the lamp pins to check for continuity of lamp filaments (see FIGURE 25).

Troubleshooting charts are provided to aid in determining the cause of any problems encountered (FIGURE 24 and FIGURE 25).

**Lamp Disposal**

**NOTE - UV Lamp Contains Mercury. Dispose According to Local, State, or Federal Laws. Refer to [www.lamprecycle.org](http://www.lamprecycle.org) or call 800-953-6669.**

**Proper Clean-up Technique in Case of Lamp Breakage**

Wear protective gloves, eye wear and mask.

Sweep the broken glass and debris into a plastic bag, seal the bag, and dispose of properly. Contact your local waste management office for proper disposal.

**Do not use a vacuum cleaner. Do not incinerate.**

**Maintenance**

- For all maintenance, contact a qualified HVAC technician.
- Read the maintenance instructions before opening unit panels.
- Unintended use of the unit or damage to the unit housing may result in the escape of dangerous UVC radiation. UVC radiation may, even in small doses, cause harm to the eyes and skin.
- Do not operate units that are obviously damaged.
- Do not discard the triangular UVC light shield or any barriers with an ultraviolet radiation symbol.
- Do not override the door interlock switch that interrupts power to the UVC light.
- Do not operate the UVC light outside of the unit.

**⚠ DANGER**

Ultraviolet (UVC) Radiation hazard.

Any exposure will cause significant eye damage and may cause skin damage.

**DO NOT** look into UVC light source.

Access panels must be in place during appliance operation.

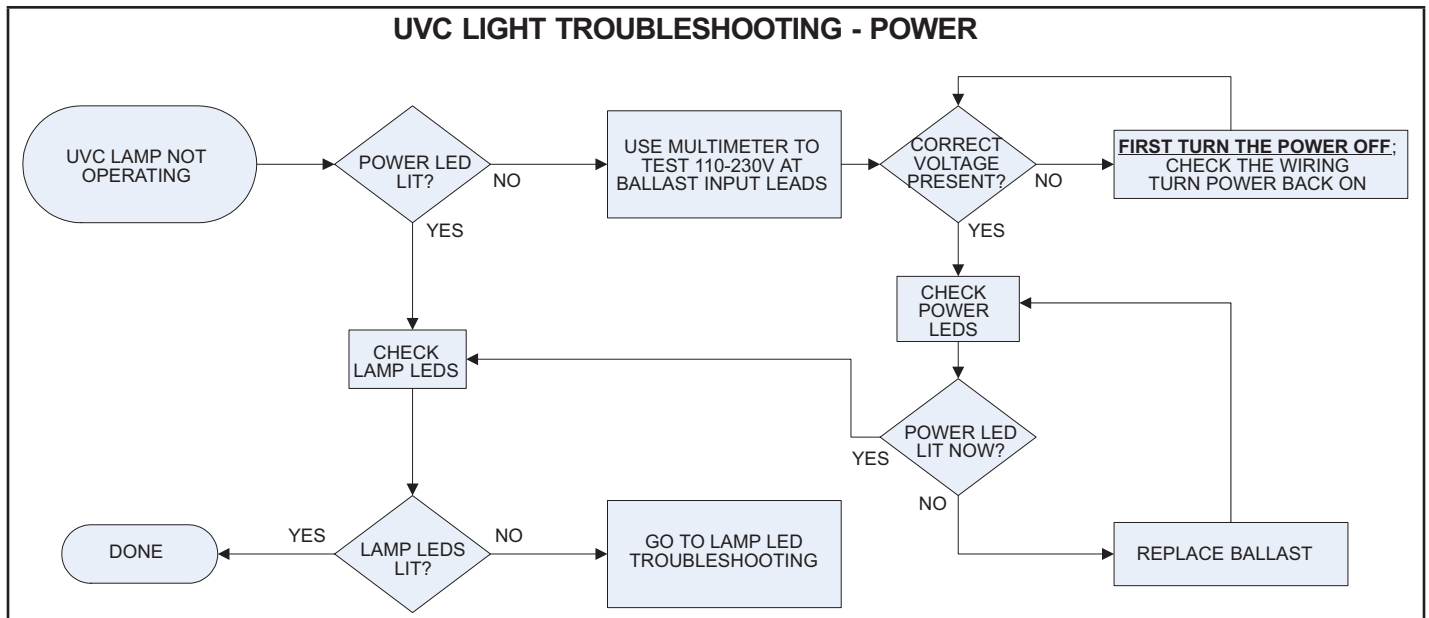

**FIGURE 24**

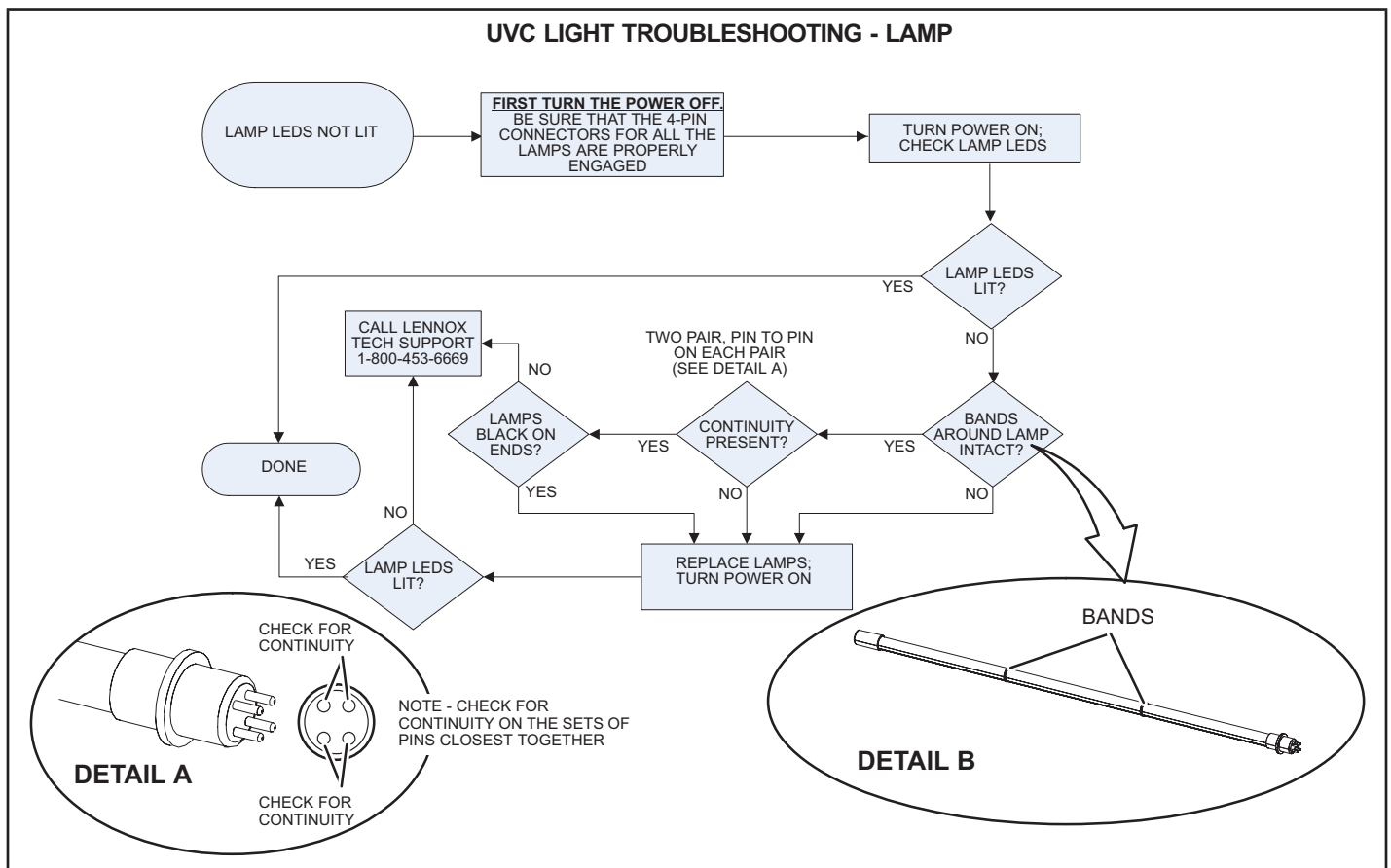

**FIGURE 25**

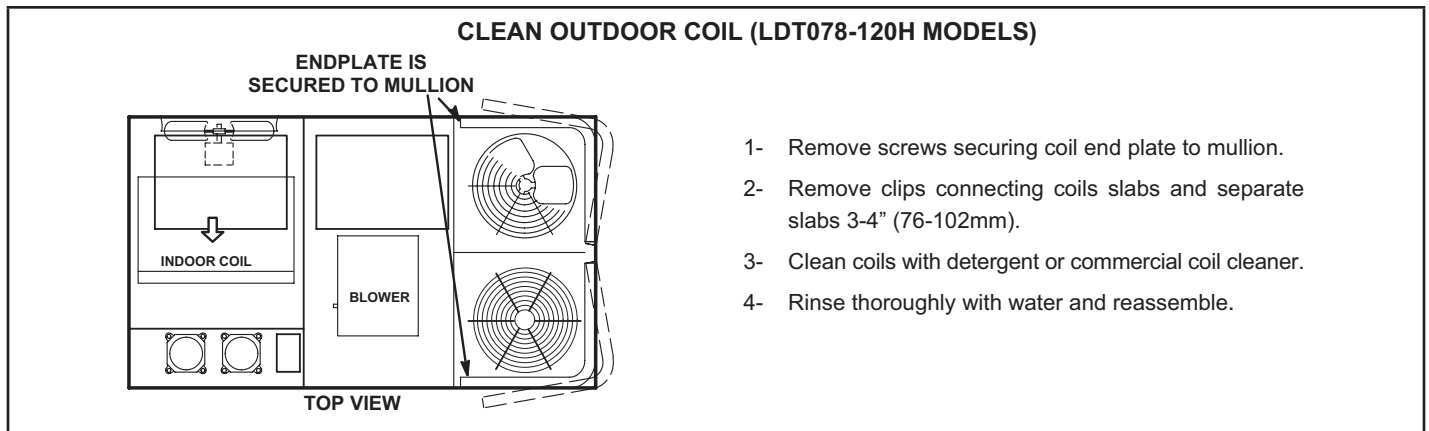

**FIGURE 26**

**A-C1CURB Mounting Frames**

When installing the LDT units on a combustible surface for downflow discharge applications, the C1CURB roof mounting frame is used. The roof mounting frames are available in heights from 8 to 24 inches and are recommended in all other applications but not required. If the LDT units are not mounted on a flat (roof) surface, they MUST be supported under all edges and under the middle of the unit to prevent sagging. The units MUST be mounted level within 1/16" per linear foot or 5mm per meter in any direction.

The assembled C1CURB mounting frame is shown in FIGURE 27. Refer to the roof mounting frame installation instructions for details of proper assembly and mounting.

The roof mounting frame MUST be squared to the roof and level before mounting. Plenum system MUST be installed before the unit is set on the mounting frame. Typical roof curbing and flashing is shown in FIGURE 28. Refer to the roof mounting frame installation instructions for proper plenum construction and attachment.

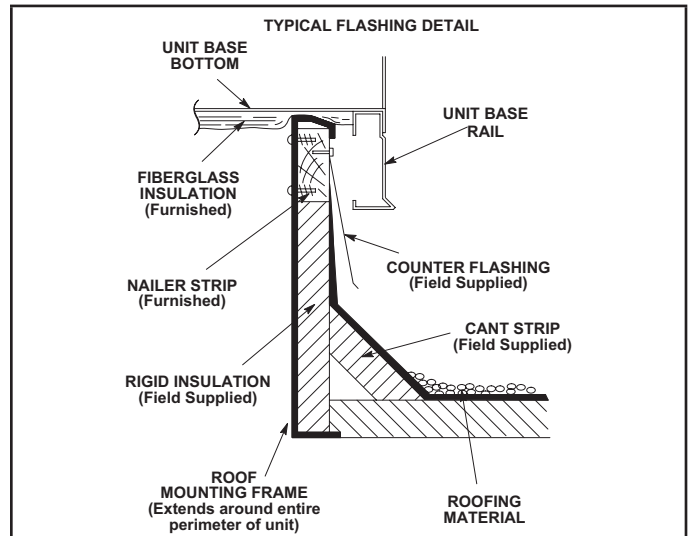
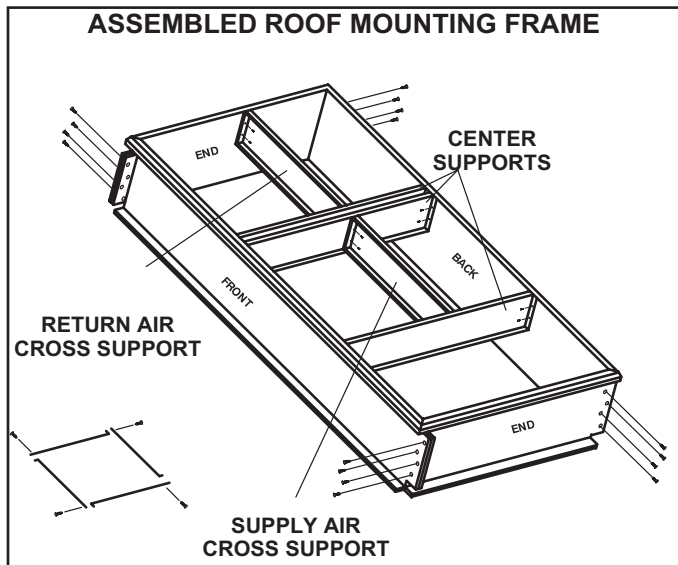

**B-Transitions**

Optional supply/return transition C1DIFF30B-1 is available for use with LDT 7.5-ton units. C1DIFF31B-1 is available for 8.5 and 10-ton units and C1DIFF32B-1 is available for use with LDT 12.5 ton units. All transitions are used with the appropriate C1CURB roof mounting frame. Transition must be installed in the mounting frame before installing the unit on the frame. Refer to the manufacturer's instructions included with the transition for detailed installation procedures.

**C-Supply and Return Diffusers**

Optional flush mount diffuser/return FD11 and extended mount diffuser/return RTD11 are available for use with all LDT units. Refer to manufacturer's instructions included with transition for detailed installation procedures.

**D-C1DAMP Outdoor Air Dampers Field- or Factory-Installed**

Optional manual (C1DAMP10B-2) and motorized (C1DAMP20B-1) outdoor air dampers provide up to 25 percent fresh air for return. Motorized damper opens to minimum position simultaneously with the blower during the occupied period and remains closed during the unoccupied period. Manual damper assembly is manually operated; damper position is manually set at installation and remains in that position.

**C1DAMP20B-1 MOTORIZED OUTDOOR AIR DAMPER**

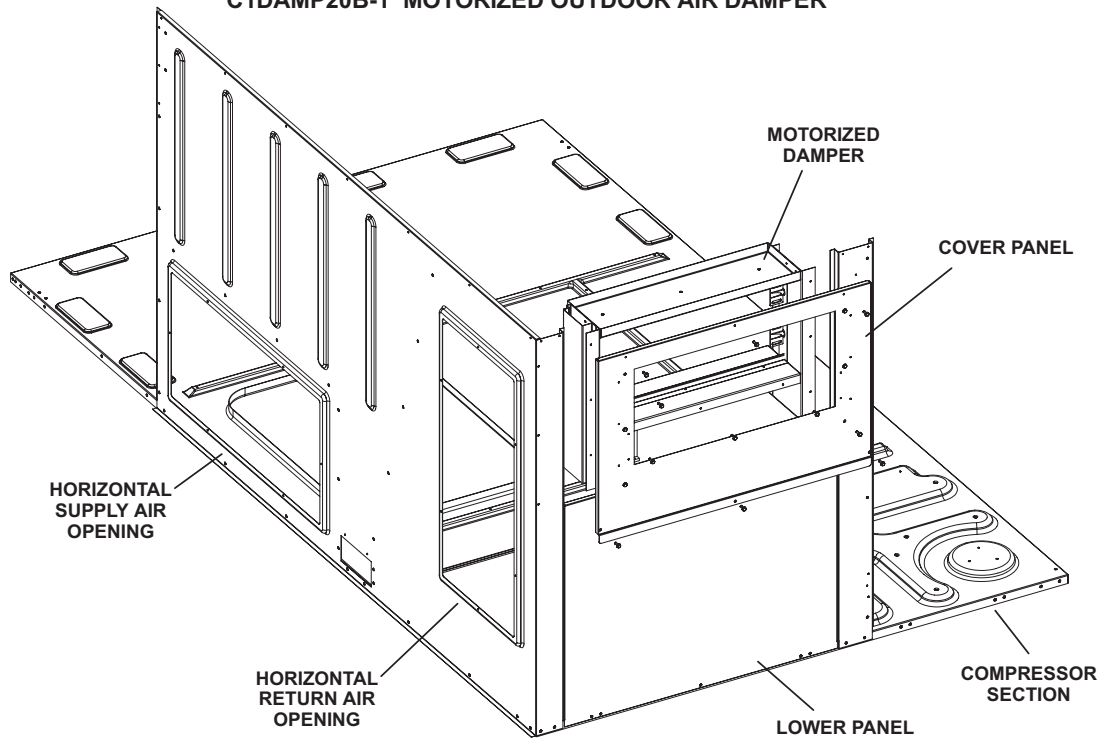

**C1DAMP10B-2 MANUAL OUTDOOR AIR DAMPER**

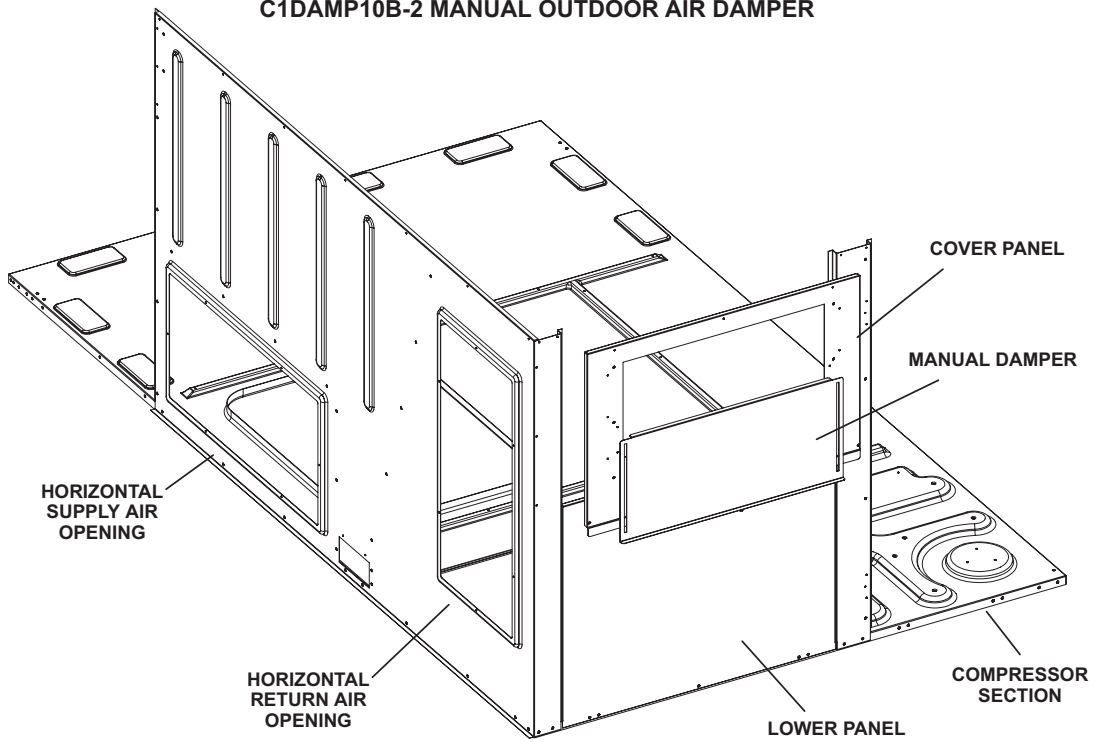

**FIGURE 29**

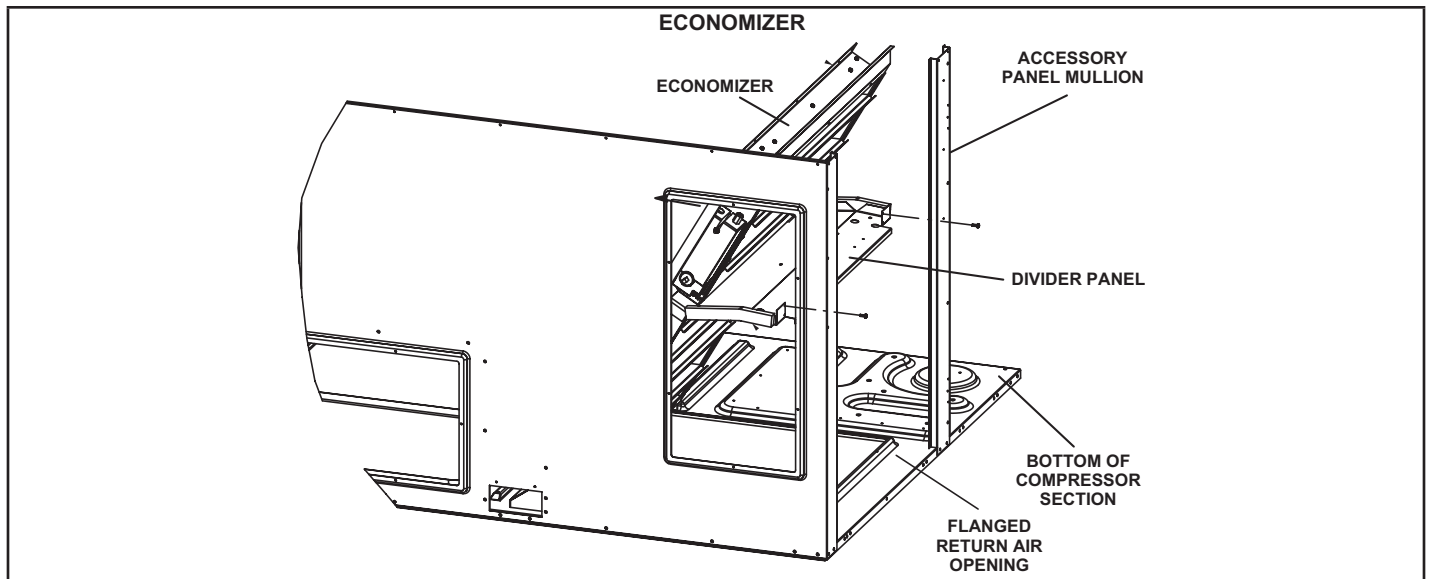

FIGURE 30

TABLE 11  
ECONOMIZER MODES AND SETPOINT

| Free Cooling Mode | Free Cooling Set Point | Field Provided Sensors     | Dampers will modulate to 55°F (default, parameter 159) discharge air (RT6) when outdoor air is suitable:   | Input Ranges |
|-------------------|------------------------|----------------------------|--|--------------|
| TEMP              | OFFSET                 | None Needed                | Outdoor air temperature (RT17) is less than return air temperature (RT16) by at least the OFFSET value (10°F default; parameter 161).  | 0-40°F       |
| TEMP              | OAT STPT               | None Needed                | Outdoor air temperature (RT17) is less than the OAT STPT value (75°F default; parameter 160).  | 41-75°F      |
| Remote            | Remote                 | Energy Management System** | Either of the TEMP modes can be used when a network OAS signal is provided by an energy management or building control system, via BACnet, LonTalk, or L Connection. The network can command OAS, NOT OAS, or AUTO. AUTO returns to local control of OAS, which is the selected TEMP mode.               | NA           |
| ENTH              | DIFF OFFSET            | (Two) C7400                | Outdoor air enthalpy* (A7) is less than return air enthalpy (A62) by at least the OFFSET value (1mA = 2°F default; parameter 163).   | 0mA-4mA      |
| ENTH              | ODE STPT               | C7400                      | Outdoor air enthalpy (A7) is less than free cooling setpoint (12mA = 75°F default, parameter 162).   | 12-19mA      |
| GLOBAL            | GLOBAL                 | 24VAC Input Signal         | Global input is energized by (P297-9). This setting is also used for outdoor air damper applications. Global input also brings on the blower. (This mode is NOT used when OAS signal is provided via network connection. GLO is only used when a 24VAC signal is used to energize the P297-9 GLO input.) | NA           |

\*Enthalpy includes effects of both temperature and humidity.

\*\*Energy management systems may require additional field-provided sensors; refer to manufacturer's instructions.

## E-K1ECON20B Economizer

### (Field- or Factory-Installed)

The optional E1ECON15 economizer can be used with downflow and horizontal air discharge applications. See FIGURE 30. The economizer uses outdoor air for free cooling when outdoor temperature and/or humidity is suitable. The economizer is controlled by the A55 Unit Controller.

### Free Cooling Mode

The Unit Controller will allow free cooling in one of five modes. Each mode uses different combinations of sensors to determine outdoor air suitability. See TABLE 11 for modes. Temperature offset is the default free cooling mode.

**NOTE** - All free cooling modes of operation will modulate dampers to 55F (13C) supply / discharge air.

### Unit Controller Settings

On early versions, switches are located on the Unit Controller to adjust settings. On newer versions, the display and keypad on the Unit Controller are used to navigate through menus to adjust settings. Some versions require a configuration ID be entered to enable the economizer. Refer to economizer installation instructions and Unit Controller installation and application manuals

### F-Barometric Relief Dampers

Dampers are used in downflow (FIGURE 31) and horizontal (FIGURE 32) air discharge applications. Horizontal barometric relief dampers are installed in the return air duct. The dampers must be used any time an economizer and a power exhaust fan is applied to LDT series units.

Barometric relief dampers allow exhaust air to be discharged from the system when an economizer and/or power exhaust is operating. Barometric relief dampers also prevent outdoor air infiltration during unit off cycle. See installation instructions for more detail.

**NOTE**- Barometric relief damper is optional except required with power exhaust dampers.

### G-Power Exhaust Fan

The power exhaust fan (K1PWRE10B) requires an optional gravity exhaust damper and economizer and is used in downflow applications only. See FIGURE 33. The power exhaust fan provides exhaust air pressure relief and also runs when return air dampers are closed and the supply air blower is operating. See installation instructions for more detail.

### Power Exhaust Setpoint Adjustment

Locate the A6 enthalpy control in the control area. The EXH SET potentiometer is factory-set at approximately 50% of the dial range. See FIGURE 34. Power exhaust fans will be energized 30 seconds after dampers are 50% open. Adjust the EXH SET potentiometer higher (clockwise toward 10V) to energize fans when dampers are further open. Adjust the EXH SET potentiometer lower (counterclockwise toward 2V) to energize fans when dampers are further closed. (Thirty-second delay allows dampers to partially open before exhaust fan starts.)

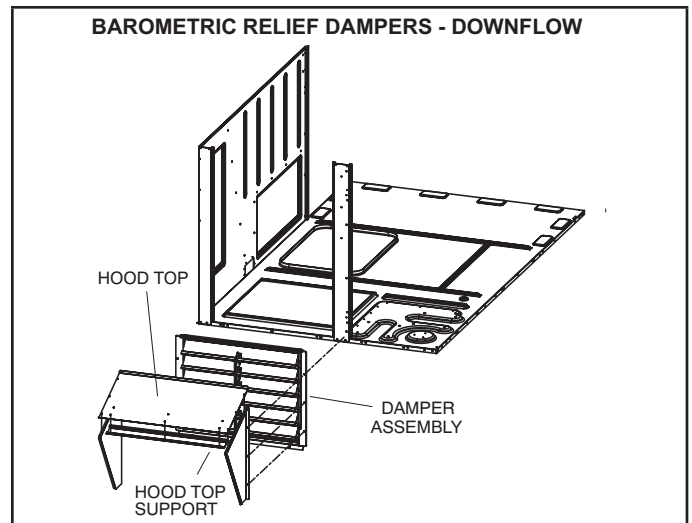

FIGURE 31

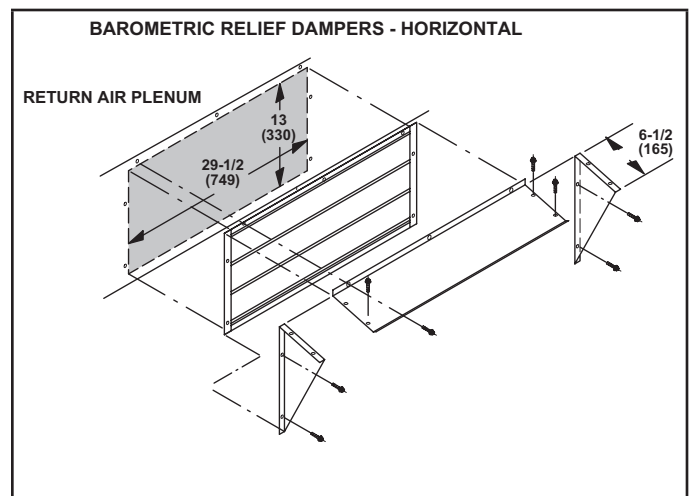

FIGURE 32

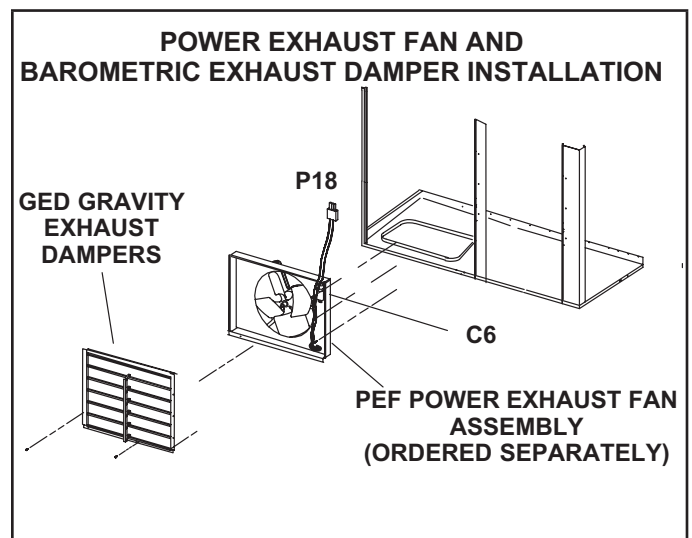

FIGURE 33

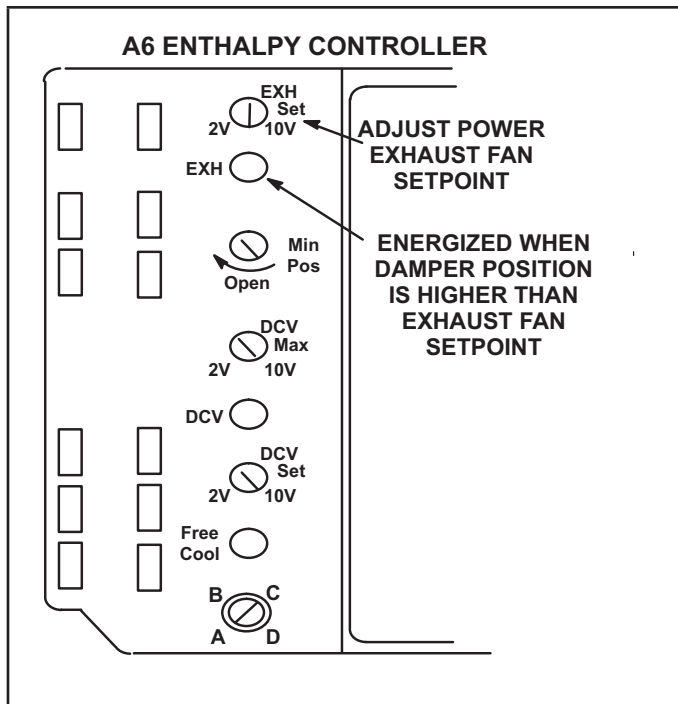

FIGURE 34

### H-Control Systems

The A55 Unit Controller provides all control function for the rooftop unit. Default operation requires a standard room thermostat or direct digital controller (DDC). The A55 can also control the unit from a zone temperature sensor. The A55 Unit Controller is a network controller when daisy-chained to the L Connection® Network Control System. For ease of configuration, the A55 can be connected to a PC with Unit Controller PC software installed.

### I-Drain Pan Overflow Switch S149 (optional)

The overflow switch is used to interrupt cooling operation when excessive condensate collects in the drain pan. The N.C. overflow switch is connected to the M2 Unit Controller (A55) through DI-3. When the switch opens, the Unit Controller will shut off the unit. After a five-minute time out, the Unit Controller will verify the overflow switch position and restart the unit (if the switch has closed). The Unit Controller has a three-strike counter before the unit locks out. This means the Unit Controller will allow the overflow switch to open three times per thermostat demand. If the unit locks out, a reset of the Unit Controller is required after the switch has closed to restore unit operation.

### J-Smoke Detectors A17 and A64

Photoelectric smoke detectors are a factory installed option. The smoke detectors can be installed in the supply air section (A64), return air section (A17), or in both the supply and return air section. Wiring for the smoke detectors are shown on the temperature control section (C2) wiring diagram in back of this manual.

### K-LP / Propane Kit

Units require a natural to LP /propane kit. The kit includes one LP spring conversion kit, up to eleven burner orifices and three stickers. For more detail refer to the natural to LP gas changeover kit installation instructions.

### L-Optional Cold Weather Kit (Canada only)

Electric heater is available to automatically control the minimum temperature in the gas burner compartment. Heater is C.G.A. certified to allow cold weather operation of unit down to -60° F (-50° C ).

The kit includes the following parts:

- 1 - Transformer (T20) is a 600V to 120/240V step-down transformer mounted in the blower compartment.
- 2 - T20 has two in line fuses (F20), one on each leg of the transformer. Both are rated at 15 amps.
- 3 - The strip heater (HR6) is located as close as possible to the gas valve. It is wired in series with T20. The strip heater is rated at 500 Watts
- 4 - A thermostat mounting box is installed on the vestibule of the heating compartment. Included in the box are the following thermostat switches:
  - a. Thermostat switch (S59) is an auto-reset SPST N.C. switch which opens on a temperature drop. The switch is wired in series with 24v power and the combustion air blower switch. When the temperature drops below -30° F (-35° C) the switch opens and the gas heat section is deenergized. The switch automatically resets when the heating compartment temperature reaches -10° F (-12° C).
  - b. Thermostat switch (S60) is an auto-reset SPST N.C. switch which opens on a temperature rise. The switch is wired in series with HR6 and T20. When the temperature rises above 20° F (-7° C) the switch opens and the electric heater is de-energized. The switch automatically resets when the heating compartment temperature reaches -10° F (23.3° C).
  - c. Thermostat switch (S61) is an auto-reset SPST N.O. switch which closes on a temperature drop. The switch is wired in series with HR6 and T20. When temperature drops below 20° F (-7° C) the switch closes and electric heater is energized. The switch automatically opens when heating compartment temperature reaches 76° F (24° C).

# VII-Wiring Diagrams and Sequence of Operation

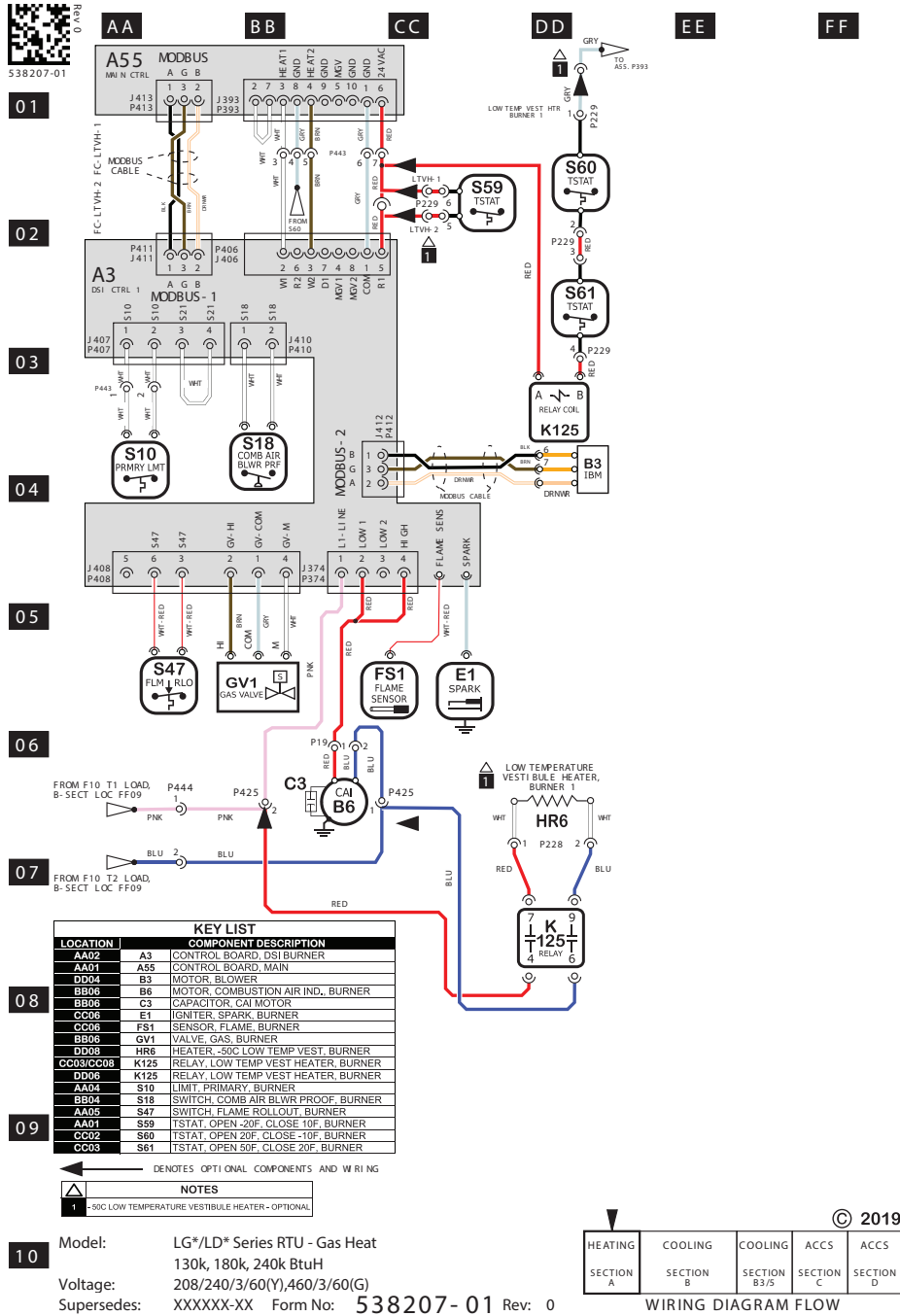

7x10  
CUT  
SIZE

| REV | EC NO.     | DATE       | BY  | APVD | REVISION NOTE                     |
|-----|------------|------------|-----|------|-----------------------------------|
| --- | CN-012081C | 04-29-2024 | FEP | MCF  | ORIGINATED AT PD&R CARROLLTON, TX |
|     |            |            |     |      |                                   |
|     |            |            |     |      |                                   |



01

02

03

04

05

06

07

08

09

10

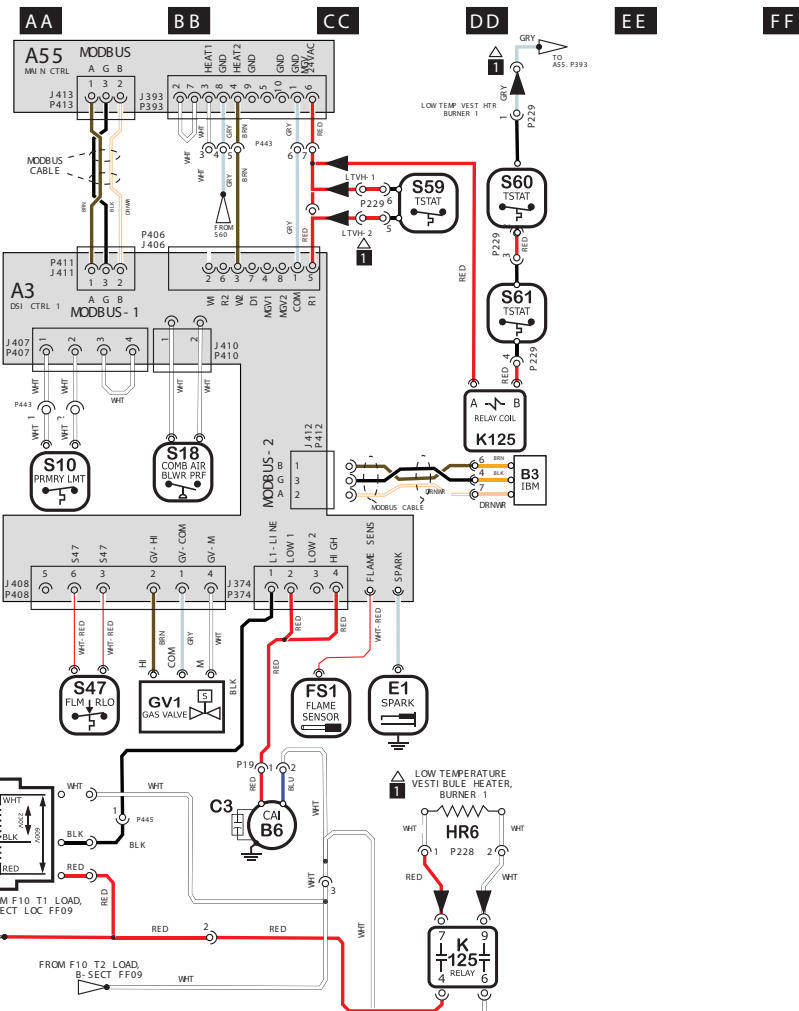

**KEY LIST**

| LOCATION  | COMPONENT DESCRIPTION                    |
|-----------|--|
| AA02      | A3 CONTROL BOARD, DSI BURNER             |
| AA01      | A55 CONTROL BOARD, MAIN                  |
| DD04      | B3 MOTOR, BLOWER                         |
| BB06      | B6 MOTOR, COMBUSTION AIR IND., BURNER    |
| BB06      | C3 CAPACITOR, CAI MOTOR                  |
| CC06      | E1 IGNITER, SPARK, BURNER                |
| CC06      | FS1 SENSOR, FLAME, BURNER                |
| BB06      | GV1 VALVE, GAS, BURNER                   |
| DD08      | HR6 HEATER, -50C LOW TEMP VEST, BURNER   |
| CC08/DD06 | K125 RELAY, LOW TEMP VEST HEATER, BURNER |
| AA04      | S10 LIMIT, PRIMARY, BURNER               |
| BB04      | S18 SWITCH, COMB AIR BLWR PRF, BURNER    |
| AA05      | S47 SWITCH, FLAME ROLL OUT, BURNER       |
| AA01      | S59 TSTAT, OPEN -20F, CLOSE 10F, BURNER  |
| CC02      | S60 TSTAT, OPEN 20F, CLOSE -10F, BURNER  |
| CC03      | S61 TSTAT, OPEN 50F, CLOSE 20F, BURNER   |
| AA06/AA07 | T3 TRANSFORMER, COMBUSTION AIR BLOWER    |

Model: LG\*/LD\* Series RTU - Gas Heat - J VOLT  
 130k, 180k, 240k BtuH  
 Voltage: 575/3/60 (J)  
 Supersedes: XXXXX-XX Form No: 538208-01 Rev: 0

← DENOTES OPTIONAL COMPONENTS AND WIRING  
 ▲ -50C LOW TEMPERATURE VESTIBULE HEATER - OPTIONAL

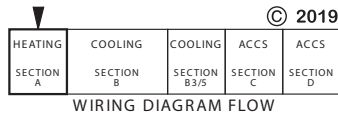

| REV | EC NO.     | DATE       | BY  | APVD | REVISION NOTE                     |
|-----|------------|------------|-----|------|-----------------------------------|
| --- | CN-012081C | 04-29-2024 | FEP | MCF  | ORIGINATED AT PD&R CARROLLTON, TX |
|     |            |            |     |      |                                   |
|     |            |            |     |      |                                   |

## GAS HEAT SEQUENCE OF OPERATION LDT078H-152H

### First Stage Heat:

- 1 - Heating demand initiates at W1 in the thermostat.
- 2 - 24VAC is routed through the A55 unit controller to A3 Ignition Control. The Ignition control then routes the 24VAC to the N.C. primary limit S10. The A3 Ignition control energizes the combustion air blower B6.
- 3 - After the combustion air blower B6 has reached full speed, the combustion air proving switch S18 contacts close. The A3 routes 24VAC through N.C. burner flame roll-out switch S47 and the closed contacts of combustion air proving switch S18 to energize the ignition module A3.
- 4 - After a 30 second delay A3 energizes the ignitor and LO terminal (low fire) of gas valve GV1.

### Second Stage Heat:

- 5 - With first stage heat operating, an additional heating demand initiates W2 in the thermostat.
- 6 - A second stage heating demand is received by A55 Unit Controller.
- 7 - A55 provides the 24VAC to the A3 Ignition control. This is routed to the HI Terminal (high fire) of gas valve GV1.

### End of Second Stage Heat:

- 8 - Heating demand is satisfied. Terminal W2 (high fire) is de-energized.
- 9 - Terminal HI of GV1 is de-energized by A3 control module.

### End of First Stage Heat:

- 10 - Heating demand is satisfied. Terminal W1 (low fire) is de-energized.
- 11 - Ignition A3 is de-energized by control module A55 in turn de-energizing terminal LO of GV1. Combustion air blower relay K13 located in the A3 ignition control is also de-energized.

### Optional Low Ambient Kit:

(C.S.A. -50° C Low Ambient Kit)

- 12 - Line voltage (or transformer T20 in 460V and 575V only) is routed through the low ambient kit fuses F20 and N.C. low ambient kit thermostats S60 and S61, to energize low ambient kit heater HR6.

# ELECTRONIC OR ELECTROMECHANICAL THERMOSTAT

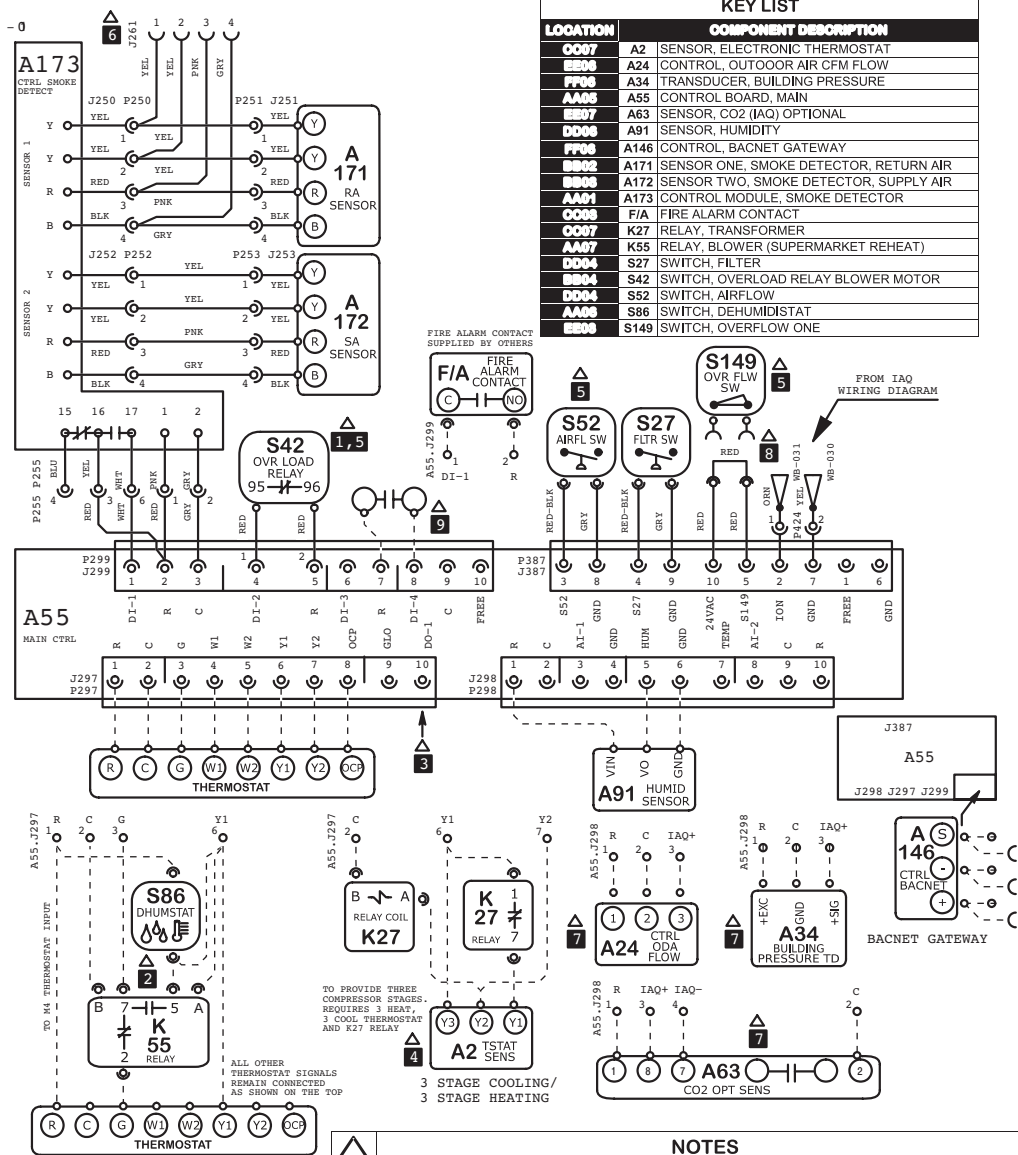

| KEY LIST |   |
|----------|---|
| LOCATION | COMPONENT DESCRIPTION                       |
| CO07     | A2 SENSOR, ELECTRONIC THERMOSTAT            |
| BB06     | A24 CONTROL, OUTDOOR AIR CFM FLOW           |
| FP06     | A34 TRANSDUCER, BUILDING PRESSURE           |
| AA05     | A55 CONTROL BOARD, MAIN                     |
| BB07     | A63 SENSOR, CO2 (IAQ) OPTIONAL              |
| DD06     | A91 SENSOR, HUMIDITY                        |
| FP06     | A146 CONTROL, BACNET GATEWAY                |
| BB02     | A171 SENSOR ONE, SMOKE DETECTOR, RETURN AIR |
| BB03     | A172 SENSOR TWO, SMOKE DETECTOR, SUPPLY AIR |
| AA01     | A173 CONTROL MODULE, SMOKE DETECTOR         |
| CC09     | F/A FIRE ALARM CONTACT                      |
| CO07     | K27 RELAY, TRANSFORMER                      |
| AA07     | K55 RELAY, BLOWER (SUPERMARKET REHEAT)      |
| DD04     | S27 SWITCH, FILTER                          |
| BB04     | S42 SWITCH, OVERLOAD RELAY BLOWER MOTOR     |
| DD04     | S52 SWITCH, AIRFLOW                         |
| AA09     | S86 SWITCH, DEHUMIDISTAT                    |
| BB09     | S149 SWITCH, OVERFLOW ONE                   |

| NOTES |   |
|-------|---|
| 1     | FOR MOTORS WITH S42 EXTERNAL OVERLOAD LESS INVERTER, SEE INVERTER WITH BY PASS FOR S42 HOOK UP  |
| 2     | USE S86 DEHUMIDISTAT AND K55 FOR OPTIONAL SUPERMARKET REHEAT SCHEME, PRODIGY PARAMETERS NEED TO BE MODIFIED UNDER THE SETTINGS MENU OR VIA UC SOFTWARE FOR SIMULTANEOUS HEATING AND COOLING |
| 3     | P297-10 (SR) IS SERVICE RELAY OUTPUT (24VAC) IF USED CONNECT TO AN INDICATOR LIGHT  |
| 4     | THERMOSTAT HOOKUP FOR PROGRAMMABLE CONFIGURATION OF THE BOARD (A55)   |
| 5     | PRODIGY SETTINGS MUST BE MODIFIED WHEN S42, S52, S149 ARE INSTALLED   |
| 6     | CONNECT P252 OF A172 SENSOR TO J261 ON SUPPLY AIR SMOKE DETECTOR ONLY   |
| 7     | FROM A63, A34 & A24, ONLY ONE CAN BE USED AT A TIME   |
| 8     | REMOVE JUMPER TO INSTALL S149   |
| 9     | EXTERNAL HUMIDITROL CONTACTS  |

Model: LC, LG, LH, LD Series RTU  
 Thermostat  
 Voltage: All Voltages  
 Supersedes: N/A Form No: 538078-01 Rev: 1

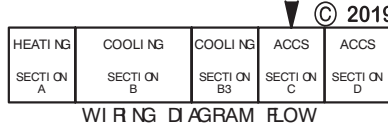

# ECONOMIZER

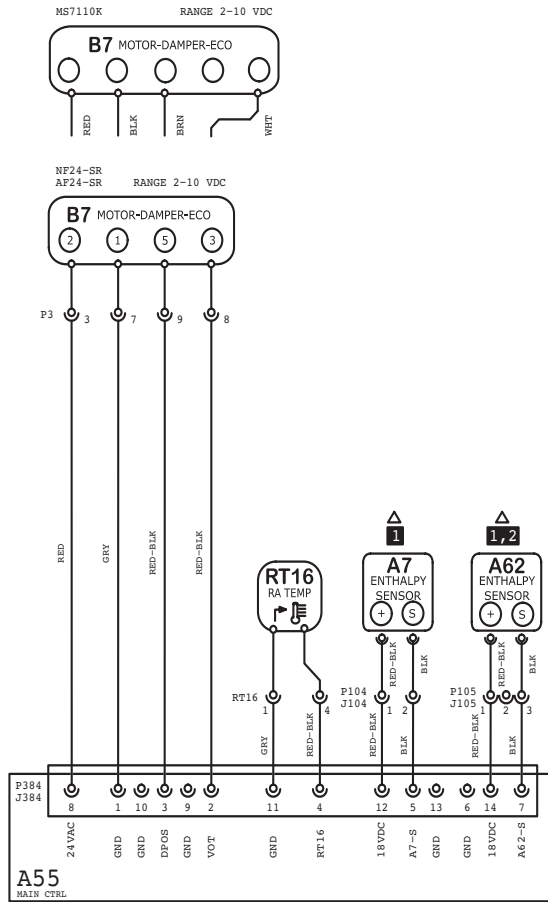

| NOTES |  |
|-------|--|
| 1     | A7 AND A62 NOT USED FOR SENSIBLE TEMPERATURE CONTROL                       |
| 2     | FOR UNIT DIFFERENTIAL ENTHALPY CONTROL, ADD A62 RETURN AIR ENTHALPY SENSOR |

| KEY LIST |                                 |
|----------|---------------------------------|
| LOCATION | COMPONENT DESCRIPTION           |
| CC05     | A7 SENSOR, SOLID STATE ENTHALPY |
| AA05     | A55 CONTROL BOARD, MAIN         |
| DD05     | A62 SENSOR, ENTHALPY INDOOR     |
| BB02     | B7 MOTOR, DAMPER ECONOMIZER     |
| CC05     | RT16 SENSOR, RETURN AIR TEMP    |

Model: LC, LG, LH, LD Series RTU  
Economizer & Motorized OAD

Voltage: All Voltages

Supersedes: N/A

Form No: 538072-01 Rev: 1

© 2019

|                 |                 |                  |                  |                  |
|-----------------|-----------------|------------------|------------------|------------------|
| HTG<br>SEC<br>A | CLG<br>SEC<br>B | OLG<br>SEC<br>B3 | ACCS<br>SEC<br>C | ACCS<br>SEC<br>D |
|-----------------|-----------------|------------------|------------------|------------------|

WI R I N G D I A G R A M F L O W

# LDT Y Volt 078-120

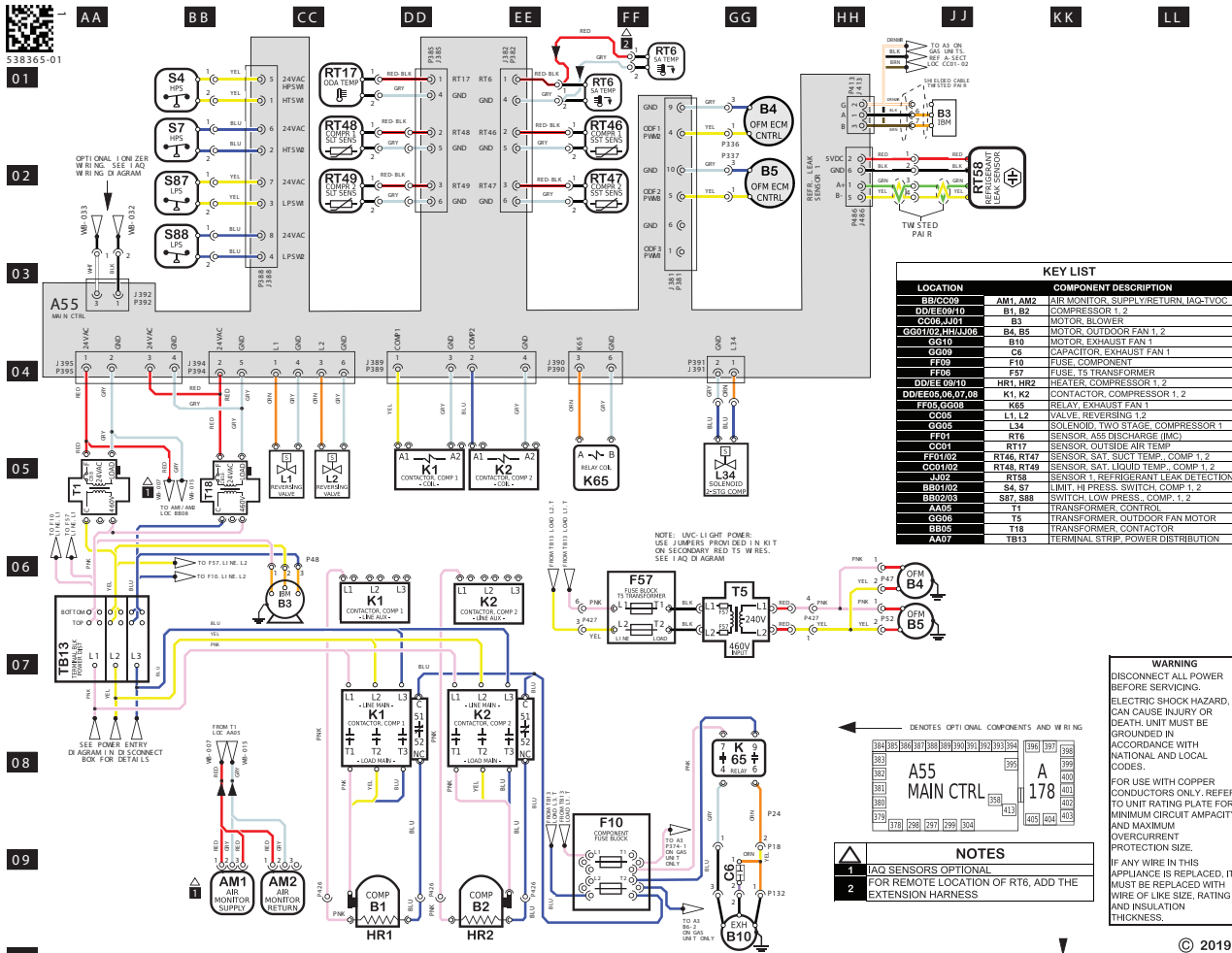

| LOCATION            | COMPONENT DESCRIPTION                          |
|---------------------|--|
| BBCC009             | AM1, AM2 AIR MONITOR, SUPPLY/RETURN, IAQ-1/0/0 |
| DDDEE0010           | B1, B2 COMPRESSOR 1, 2                         |
| CC00-A101           | B3 MOTOR, BLOWER                               |
| GG0102, HH1, J08    | B4, B5 MOTOR, OUTDOOR FAN 1, 2                 |
| CC010               | B10 MOTOR, EXHAUST FAN 1                       |
| GG09                | C6 CAPACITOR, EXHAUST FAN 1                    |
| FF09                | F10 FUSE, COMPONENT                            |
| FF05                | F57 FUSE, TS TRANSFORMER                       |
| DDDEE0010           | HR1, HR2 HEATER, COMPRESSOR 1, 2               |
| DDDEE05, 06, 07, 08 | K1, K2 CONTACTOR, COMPRESSOR 1, 2              |
| FF05, GG09          | K65 RELAY, EXHAUST FAN 1                       |
| CC05                | L1, L2 VALVE, REVERSING 1, 2                   |
| GG05                | L3, L4 SOLENOID, TWO STAGE, COMPRESSOR 1       |
| FF01                | RT6 SENSOR, ASS DISCHARGE (IMC)                |
| CC01                | RT17 SENSOR, OUTSIDE AIR TEMP                  |
| FF0102              | RT46, RT47 SENSOR, SAT. LIQUID TEMP, COMP 1, 2 |
| CC0102              | RT48, RT49 SENSOR, SAT. LIQUID TEMP, COMP 1, 2 |
| LV02                | RT59 SENSOR, 1, REFRIGERANT LEAK DETECTION     |
| BB0102              | S4, S7 LIMIT, HI PRESS, SWITCH, COMP 1, 2      |
| BB0203              | S87, S88 SWITCH, LOW PRESS, COMP 1, 2          |
| AA05                | T1 TRANSFORMER, CONTROL                        |
| GG06                | T5 TRANSFORMER, OUTDOOR FAN MOTOR              |
| BB05                | T18 TRANSFORMER, CONTACTOR                     |
| AA07                | TB13 TERMINAL STRIP, POWER DISTRIBUTION        |

**WARNING**  
DISCONNECT ALL POWER BEFORE SERVICING. ELECTRIC SHOCK HAZARD, CAN CAUSE INJURY OR DEATH. UNIT MUST BE GROUNDED IN ACCORDANCE WITH NATIONAL AND LOCAL CODES.  
FOR USE WITH COPPER CONDUCTORS ONLY. REFER TO UNIT RATING PLATE FOR MINIMUM CIRCUIT AMPACITY AND MAXIMUM OVERCURRENT PROTECTION SIZE.  
IF ANY WIRE IN THIS APPLIANCE IS REPLACED, IT MUST BE REPLACED WITH WIRE OF LIKE SIZE, RATING AND INSULATION THICKNESS.

← DENOTES OPTIONAL COMPONENTS AND WIRING

|               |       |     |     |     |     |     |     |     |     |     |     |
|---------------|-------|-----|-----|-----|-----|-----|-----|-----|-----|-----|-----|
| 396           | 385   | 380 | 387 | 388 | 389 | 392 | 393 | 394 | 396 | 397 | 398 |
| A55 MAIN CTRL |       |     |     |     |     |     |     |     |     |     |     |
| 399           | A 178 |     |     |     |     |     |     |     |     |     | 398 |
| 381           | 382   | 383 | 384 | 386 | 388 | 389 | 390 | 391 | 392 | 393 | 394 |
| 395           | 396   | 397 | 398 | 399 | 400 | 401 | 402 | 403 | 404 | 405 | 406 |
| 397           | 398   | 399 | 400 | 401 | 402 | 403 | 404 | 405 | 406 | 407 | 408 |

**NOTES**  
1 IAQ SENSORS OPTIONAL  
2 FOR REMOTE LOCATION OF RT6, ADD THE EXTENSION HARNESS

© 2019

|                   |                   |                     |                |                |
|-------------------|-------------------|---------------------|----------------|----------------|
| HEATING SECTION A | COOLING SECTION B | COOLING SECTION B/B | ACCS SECTION C | ACCS SECTION D |
|-------------------|-------------------|---------------------|----------------|----------------|

Product: LHT, LDT B Box - G & J VOLT 078-120 Heat Pump Diagram with Higher SCCR  
Voltage: 460V/3~60Hz (G)  
Supersedes: XXXXX-XX Form No: 538365-01 Rev: 1

| REV | EC NO      | DATE       | BY  | APVD | REVISION NOTE                              |
|-----|------------|------------|-----|------|--|
| 001 | CN-012081C | 04-29-2024 | FEP | MCF  | ORIGINATED AT PD&R CARROLLTON, TX          |
| 001 | CN-012081W | 10-07-2024 | FEP | EXY  | UPDATED P18 CONNECTORS FROM 3 & 4 TO 1 & 2 |



# LDT G & J Volt 078-120

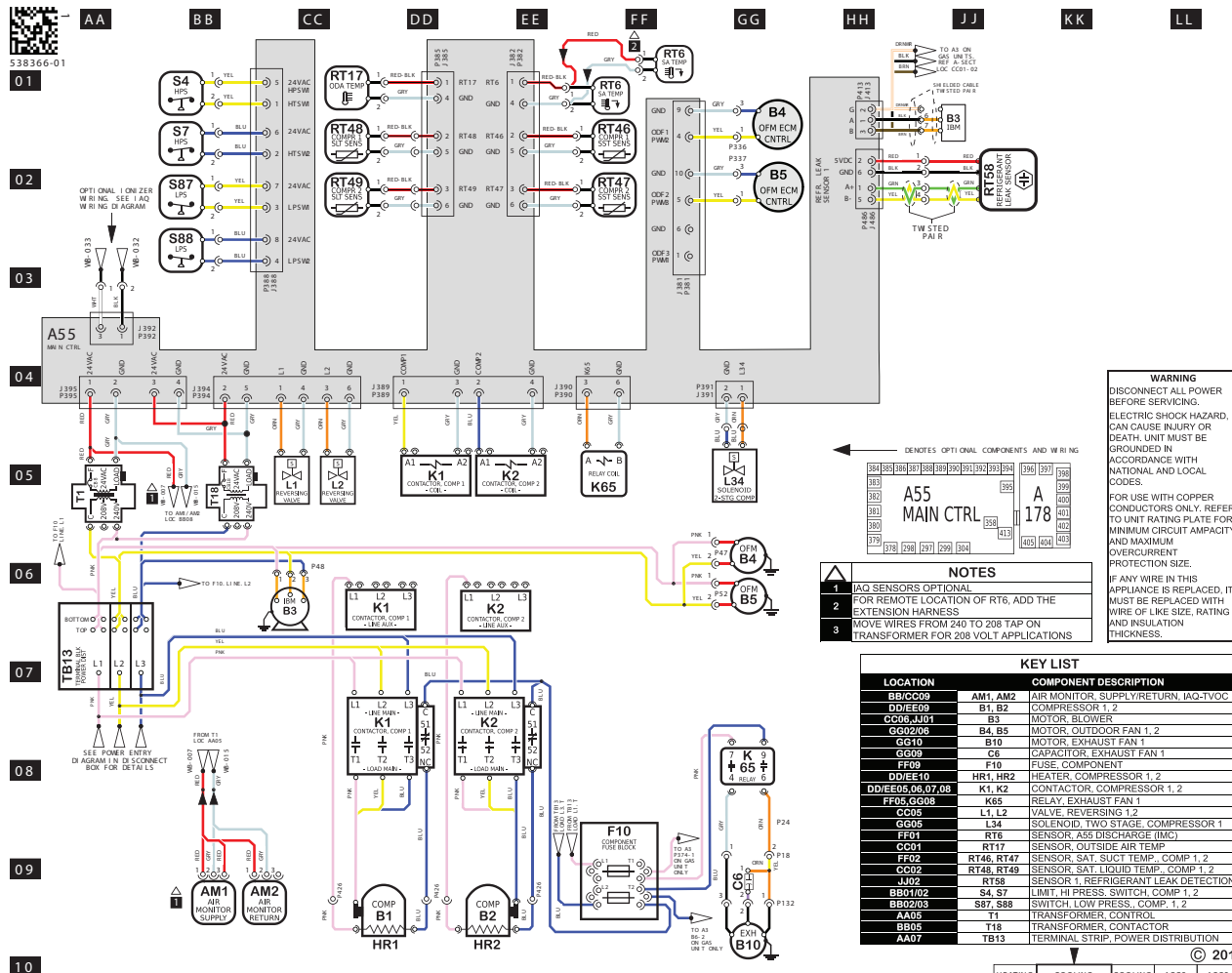

**WARNING**  
DISCONNECT ALL POWER BEFORE SERVICING.  
ELECTRIC SHOCK HAZARD. CAN CAUSE INJURY OR DEATH. UNIT MUST BE GROUNDED IN ACCORDANCE WITH NATIONAL AND LOCAL CODES.  
FOR USE WITH COPPER CONDUCTORS ONLY. REFER TO UNIT RATING PLATE FOR MINIMUM CIRCUIT AMPACITY AND MAXIMUM OVERCURRENT PROTECTION SIZE.  
IF ANY WIRE IN THIS APPLIANCE IS REPLACED, IT MUST BE REPLACED WITH WIRE OF LIKE SIZE, RATING AND INSULATION THICKNESS.

DENOTES OPTI ONAL COMPONENTS AND WIRING  
**A55 MAIN CTRL**  
**A 178**  
**NOTES**  
 1 IAQ SENSORS OPTIONAL  
 2 FOR REMOTE LOCATION OF RT6, ADD THE EXTENSION HARNESS  
 3 MOVE WIRES FROM 240 TO 208 TAP ON TRANSFORMER FOR 208 VOLT APPLICATIONS

**KEY LIST**

| LOCATION            | COMPONENT DESCRIPTION                          |
|---------------------|--|
| BB/CC09             | AM1, AM2 AIR MONITOR, SUPPLY/RETURN, IAQ-TVOC  |
| DD/EE09             | B1, B2 COMPRESSOR 1, 2                         |
| CC06, JJ01          | B3 MOTOR, BLOWER                               |
| GG02/06             | B4, B5 MOTOR, OUTDOOR FAN 1, 2                 |
| GG10                | B10 MOTOR, EXHAUST FAN 1                       |
| GG03                | C6 CAPACITOR, EXHAUST FAN 1                    |
| FF09                | F10 FUSE, COMPONENT                            |
| DD/EE10             | HR1, HR2 HEATER, COMPRESSOR 1, 2               |
| DD/EE05, DD, 07, 08 | K1, K2 CONTACTOR, COMPRESSOR 1, 2              |
| FF05, CC08          | K65 RELAY, EXHAUST FAN 1                       |
| CC05                | L1, L2 VALVE, REVERSING 1, 2                   |
| GG05                | L34 SOLENOID, TWO STAGE, COMPRESSOR 1          |
| FF01                | RT6 SENSOR, A55 DISCHARGE (IMC)                |
| CC01                | RT17 SENSOR, OUTSIDE AIR TEMP                  |
| FF02                | RT46, RT47 SENSOR, SAT. SUCT TEMP, COMP 1, 2   |
| CC02                | RT48, RT49 SENSOR, SAT. LIQUID TEMP, COMP 1, 2 |
| JJ02                | RT59 SENSOR 1, REFRIGERANT LEAK DETECTION      |
| BB01/02             | S4, S7 LIMIT, HI PRESS, SWITCH, COMP 1, 2      |
| BB02/03             | S87, S88 SWITCH, LOW PRESS, COMP 1, 2          |
| AA05                | T1 TRANSFORMER, CONTROL                        |
| FF05                | T18 TRANSFORMER, CONTACTOR                     |
| AA07                | TB13 TERMINAL STRIP, POWER DISTRIBUTION        |

**WIRING DIAGRAM FLOW**

| HEATING SECTION A | COOLING SECTION B | COOLING SECTION B15 | ACCS SECTION C | ACCS SECTION D |
|-------------------|-------------------|---------------------|----------------|----------------|
|                   |                   |                     |                |                |

Product: LHT, LDT B Box - Y VOLT 078-120  
Heat Pump Diagram with Higher SCCR

Voltage: 208-230V/3-~60Hz (Y)  
Supersedes: XXXXX-XX Form No: 538366-01 Rev: 1

| REV | EC NO.     | DATE       | BY  | APVD | REVISION NOTE                              |
|-----|------------|------------|-----|------|--|
| 001 | CN-012081C | 04-29-2024 | FEP | MCF  | ORIGINATED AT PD&R CARROLLTON, TX          |
| 001 | CN-012081W | 10-07-2024 | FEP | FXY  | UPDATED P18 CONNECTORS FROM 3 & 4 TO 1 & 2 |



# LDT G & J Volt 152

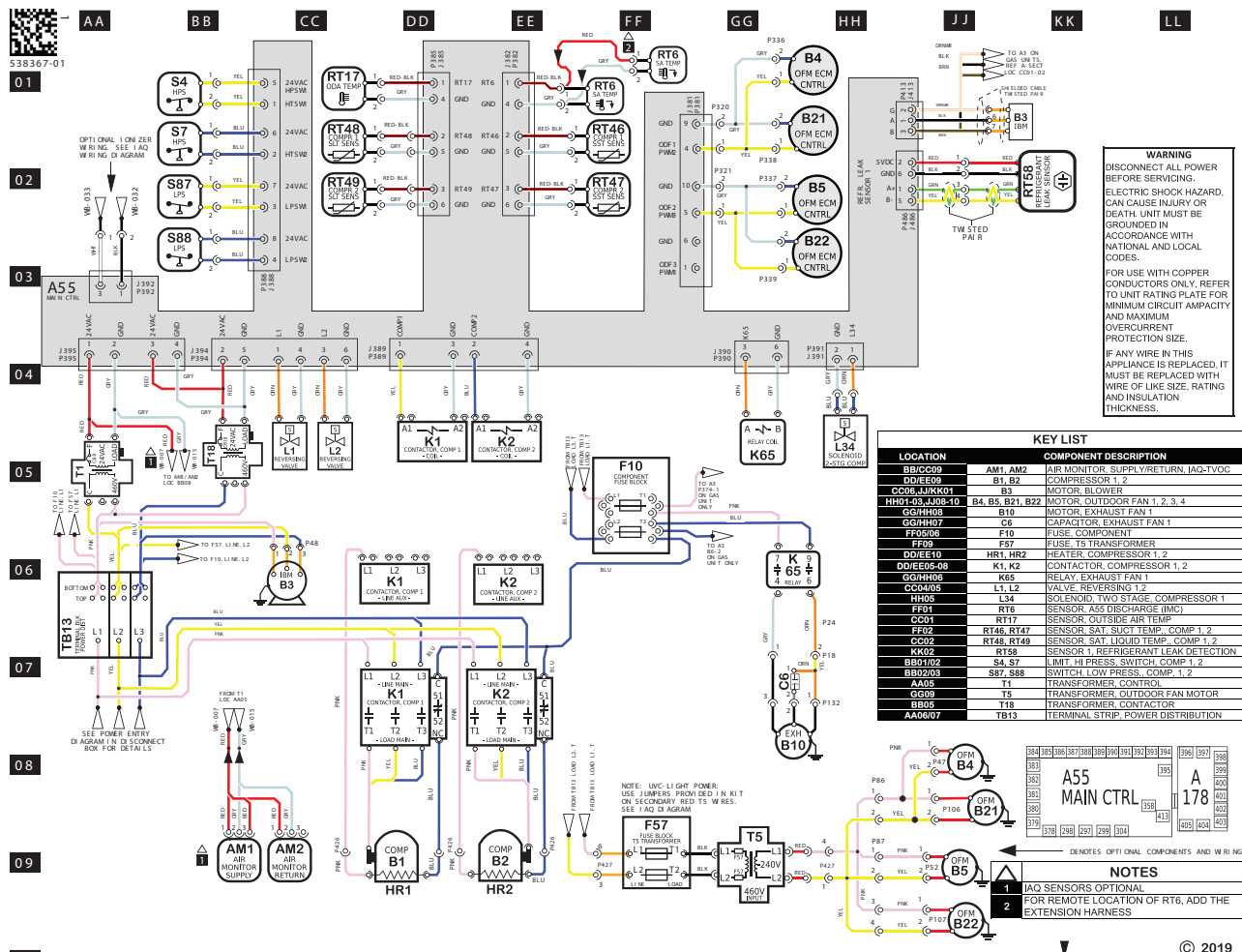

**WARNING**  
DISCONNECT ALL POWER BEFORE SERVICING. ELECTRIC SHOCK HAZARD, CAN CAUSE INJURY OR DEATH. UNIT MUST BE GROUNDING IN ACCORDANCE WITH NATIONAL AND LOCAL CODES.  
FOR USE WITH COPPER CONDUCTORS ONLY, REFER TO UNIT RATING PLATE FOR MINIMUM CIRCUIT AMPACITY AND MAXIMUM OVERCURRENT PROTECTION SIZE.  
IF ANY WIRE IN THIS APPLIANCE IS REPLACED, IT MUST BE REPLACED WITH WIRE OF LIKE SIZE, RATING AND INSULATION THICKNESS.

**KEY LIST**

| LOCATION          | COMPONENT DESCRIPTION                           |
|-------------------|---|
| BB/CC/09          | AM1, AM2 AIR MONITOR, SUPPLY/RETURN, IAQ-TVOC   |
| DD/EE/09          | B1, B2 COMPRESSOR 1, 2                          |
| GG/HH/JK/K01      | B3 MOTOR, BLOWER                                |
| HH/1-43, AA/05-10 | B4, B5, B21, B22 MOTOR, OUTDOOR FAN 1, 2, 3, 4  |
| GG/HH/08          | B10 MOTOR, EXHAUST FAN 1                        |
| GG/HH/07          | C6 CAPACITOR, EXHAUST FAN 1                     |
| FF/09/08          | F10 FUSE, COMPONENT                             |
| FF/09             | F57 FUSE, T5 TRANSFORMER                        |
| DD/EE/10          | HR1, HR2 HEATER, COMPRESSOR 1, 2                |
| DD/EE/05-09       | K1, K2 CONTACTOR, COMPRESSOR 1, 2               |
| GG/HH/06          | K65 RELAY, EXHAUST FAN 1                        |
| CC/04/05          | L1, L2 VALVE, REVERSING 1, 2                    |
| HH/05             | L34 SOLENOID, TWO STAGE, COMPRESSOR 1           |
| FF/01             | RT6 SENSOR, ASS DISCHARGE (IMC)                 |
| CC/01             | RT17 SENSOR, OUTSIDE AIR TEMP                   |
| FF/02             | RT46, RT47 SENSOR, SAT. SUCT. TEMP., COMP 1, 2  |
| CC/02             | RT48, RT49 SENSOR, SAT. LIQUID TEMP., COMP 1, 2 |
| KK/02             | RT88 SENSOR 1, REFRIGERANT LEAK DETECTION       |
| BB/01/02          | S4, S7 LIMIT, HI PRESS. SWITCH, COMP 1, 2       |
| BB/02/03          | S87, S88 SWITCH, LOW PRESS., COMP 1, 2          |
| AA/05             | T1 TRANSFORMER, CONTROL                         |
| GG/09             | T5 TRANSFORMER, OUTDOOR FAN MOTOR               |
| BB/05             | T18 TRANSFORMER, CONTACTOR                      |
| AA/06/07          | YB13 TERMINAL STRIP, POWER DISTRIBUTION         |

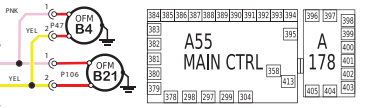

**NOTES**  
1 IAQ SENSORS OPTIONAL  
2 FOR REMOTE LOCATION OF RT6, ADD THE EXTENSION HARNESS

**WIRING DIAGRAM FLOW**

| HEATING SECTION A | COOLING SECTION B | COOLING SECTION B1/B | ACCES SECTION C | ACCES SECTION D |
|-------------------|-------------------|----------------------|-----------------|-----------------|
|-------------------|-------------------|----------------------|-----------------|-----------------|

- 01
- 02
- 03
- 04
- 05
- 06
- 07
- 08
- 09
- 10

Product: LHT, LDT B Box - G & J VOLT 152 Heat Pump Diagram with Higher SCCR

Voltage: 460V/3~60Hz (G)  
Supersedes: XXXXX-XX Form No: 538367-01 Rev: 1



| REV | EC NO.     | DATE       | BY  | APVD | REVISION NOTE                             |
|-----|------------|------------|-----|------|---|
| --- | CN-012081C | 04-29-2024 | FEP | MCF  | ORIGINATED AT PD&R CARROLLTON, TX         |
| 001 | CN-012081W | 10-07-2024 | FEP | FXV  | UPDATED P18 CONNECTOR FROM 3 & 4 TO 1 & 2 |

# LDT Y Volt 152

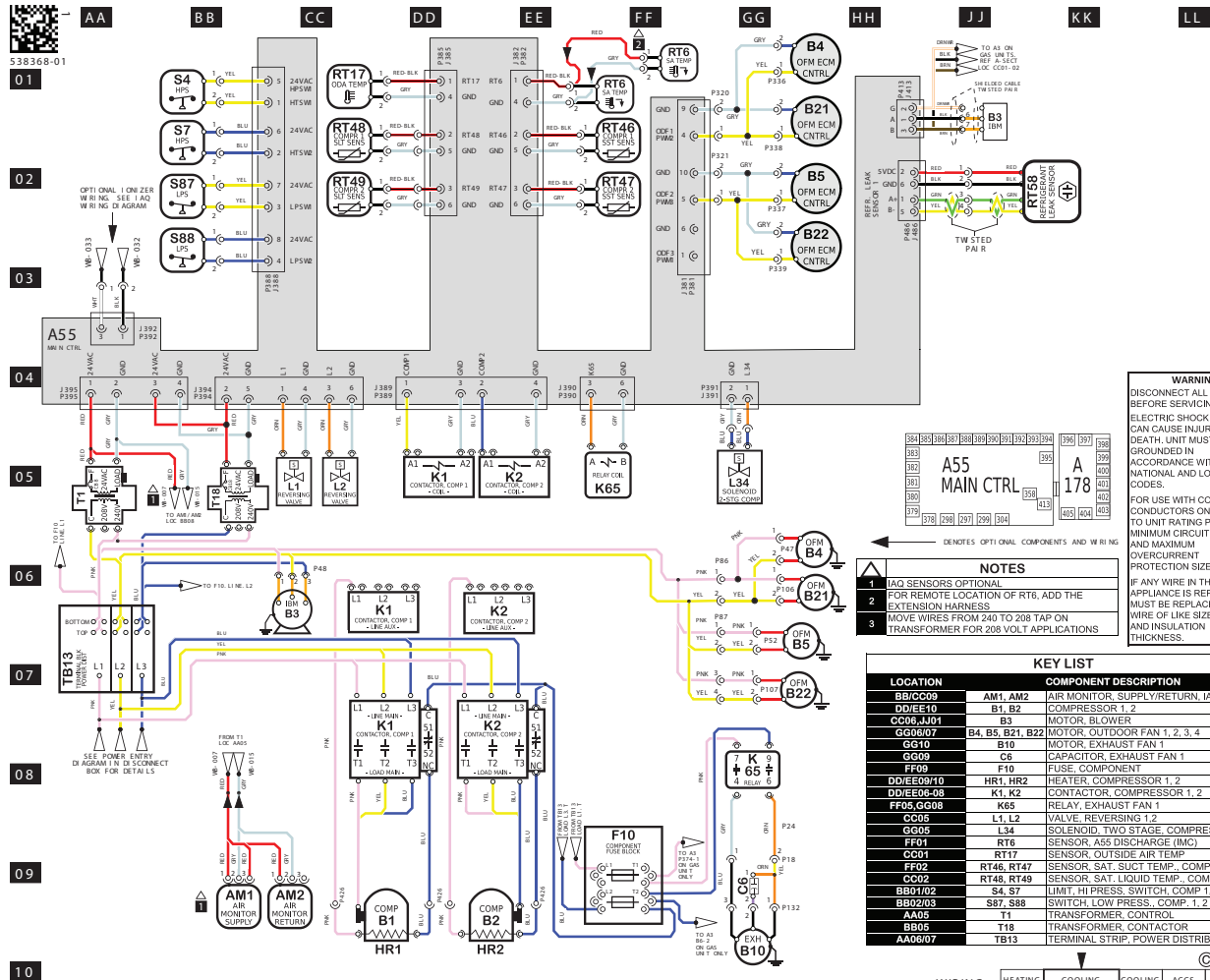

**WARNING**  
 DISCONNECT ALL POWER BEFORE SERVICING.  
 ELECTRIC SHOCK HAZARD. CAN CAUSE INJURY OR DEATH. UNIT MUST BE GROUNDED IN ACCORDANCE WITH NATIONAL AND LOCAL CODES.  
 FOR USE WITH COPPER CONDUCTORS ONLY. REFER TO UNIT RATING PLATE FOR MINIMUM CIRCUIT AMPACITY AND MAXIMUM OVERCURRENT PROTECTION SIZE.  
 IF ANY WIRE IN THIS APPLIANCE IS REPLACED, IT MUST BE REPLACED WITH WIRE OF LIKE SIZE, RATING AND INSULATION THICKNESS.

- NOTES**
- IAQ SENSORS OPTIONAL
  - FOR REMOTE LOCATION OF RT6, ADD THE EXTENSION HARNESS
  - MOVE WIRES FROM 240 TO 208 TAP ON TRANSFORMER FOR 208 VOLT APPLICATIONS

**KEY LIST**

| LOCATION   | COMPONENT DESCRIPTION                          |
|------------|--|
| BB/CC09    | AM1, AM2 AIR MONITOR, SUPPLY/RETURN, IAQ-TVOC  |
| DD/EE10    | B1, B2 COMPRESSOR 1, 2                         |
| CC06, JJ01 | B3 MOTOR, BLOWER                               |
| GG06/07    | B4, B5, B21, B22 MOTOR, OUTDOOR FAN 1, 2, 3, 4 |
| GG10       | B10 MOTOR, EXHAUST FAN 1                       |
| GG09       | C6 CAPACITOR, EXHAUST FAN 1                    |
| FF09       | F10 FUSE, COMPONENT                            |
| DD/EE09/10 | HR1, HR2 HEATER, COMPRESSOR 1, 2               |
| DD/EE08/09 | K1, K2 CONTACTOR, COMPRESSOR 1, 2              |
| FF05, GG08 | K65 RELAY, EXHAUST FAN 1                       |
| CG05       | L1, L2 VALVE, REVERSING 1, 2                   |
| GG05       | L34 SOLENOID, TWO STAGE, COMPRESSOR 1          |
| FF01       | RT6 SENSOR, AS5 DISCHARGE (IMC)                |
| CC01       | RT17 SENSOR, OUTSIDE AIR TEMP                  |
| FF02       | RT46, RT47 SENSOR, SAT. SUCT TEMP, COMP 1, 2   |
| CC02       | RT48, RT49 SENSOR, SAT. LIQUID TEMP, COMP 1, 2 |
| BB01/02    | S4, S7 LIMIT, HI PRESS, SWITCH, COMP 1, 2      |
| BB02/03    | S87, S88 SWITCH, LOW PRESS, COMP, 1, 2         |
| AA05       | T1 TRANSFORMER, CONTROL                        |
| BB05       | T18 TRANSFORMER, CONTACTOR                     |
| AA06/07    | TB13 TERMINAL STRIP, POWER DISTRIBUTION        |

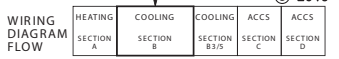

Product: LHT, LDT B Box - Y VOLT 152  
 Heat Pump Diagram with Higher SCCR

Voltage: 208-230V/3~/60Hz (Y)  
 Supersedes: XXXXXX-XX Form No: 538368-01 Rev: 1



| REV | EC NO.     | DATE       | BY  | APVD | REVISION NOTE                              |
|-----|------------|------------|-----|------|--|
| —   | CN-012081C | 04-29-2024 | FEP | MCF  | ORIGINATED AT PD&R CARROLLTON, TX          |
| 001 | CN-012081W | 10-07-2024 | FEP | FXY  | UPDATED P18 CONNECTORS FROM 3 & 4 TO 1 & 2 |

## LDT078-152H SEQUENCE OF OPERATION

### Power:

- 1 - Line voltage through the S48 unit disconnect, TB2 terminal block, or CB10 circuit breaker energizes the T1 transformer. T1 provides 24VAC power to A55 Unit Controller which provides 24VAC to the unit cooling, heating and blower controls.
- 2 - Line voltage is also routed to compressor crankcase heaters, compressor contactors, the blower motor, condenser fan relays and exhaust fan relays.

### Blower Operation:

- 3 - The A55 Unit Controller module receives a demand from thermostat terminal G.
- 4 - B3 receives the pre-set blower setting through MODUS. Economizer Operation:
- 5 - A55 receives a demand and energizes exhaust fan relay K65 with 24VAC at 50% outside air damper open (adjustable).
- 6 - N.O. K65-1 and N.O. K65-2 both close, energizing exhaust fan motor B10.

### First Stage Cooling Demand (compressor B1)

- 7 - A55 receives a Y1 thermostat demand.
- 8 - After A55 proves N.C. low pressure switch S87, RT46 reading above freeze point and N.C. high pressure switch S4, compressor contactor K1 is energized.
- 9 - N.O. contacts K1-1 close energizing compressor B1. Crankcase heater HR1 is de-energized.
- 10 - At the same time condenser fans B4 and B5 and are energized.

### Second Stage Cooling Demand (compressor B2)

- 11 - A55 receives a Y2 thermostat demand.
- 12 - After A55 proves N.C. low pressure switch S88, RT47 reading above freeze point, and N.C. high pressure switch S7, compressor contactor K2 is energized.
- 13 - N.O. contacts K2-1 close energizing compressor B2. Crankcase heater HR2 is de-energized.

### 3rd Stage Cooling (compressor B1 in full load and compressor 2 is energized)

- 14 - A55 receives a Y3 thermostat demand (Y1 + Y2 thermostat inputs).
- 15 - A55 sends 24VAC to B1 compressor solenoid (L14), B1 compressor runs at full load.

**SEQUENCE OF OPERATION LDT078-152 (continued)**

| Outdoor Ambient Temperature                   | W1 Demand                        | W2 Demand                         |
|---|----------------------------------|-----------------------------------|
| Above Balance Point<br>*Temperature Setting** | Compr. 1 & 2 On*<br>Gas Heat Off | Compr. 1 & 2 Off<br>Gas Heat High |
| Below Balance Point<br>Temperature Setting**  | Compr. 1 & 2 Off<br>Gas Heat Low | Compr. 1 & 2 Off<br>Gas Heat High |

\*L1 and L2 reversing valves are de-energized with a heating demand. The heat pump will heat only, not cool.

\*\*Balance Point temperature setting can be adjusted using the following mobile service app menu path:

RTU MENU > SETTING > RTU OPTIONS > EDIT PARAMETER = 526 (HP DF BALANCE POINT)

**First Stage Heat - OD Temp ABOVE Balance Point (35°F Default)**

- 1 - Unit controller A55 receives W1 demand. If the OD air temperature is above the balance point setpoint ( 35 F default), HP heating is initiated.
- 2 - After A55 proves N.C. low pressure switch S87, S88 high pressure switch S4, S7 compressors contactors K1, K2 are energized.
- 3 - K1-1 and K2-1 close energizing compressor B1 and B2. K1 and K2 auxiliary switch open de-energizing crankcase heaters.
- 4 - Outdoor ECM fans B4, B5 and (B21, B22 in LDT152 units) receive pre-set fan settings at high speed from A55 unit controller.

**First Stage Heat - OD Temp BELOW Balance Point (35°F Default)**

- 5 - Unit controller A55 receives W1 demand. If the OD air temperature is BELOW the balance point setpoint ( 35 F default), it will activate for low gas heat.
- 6 - See sequence of operation for gas heat.

**NOTE -** For first stage heat, the OD temp is only checked upon a change in demand. The controller will continue with the selected heat source until a change in heating demand is received.

**NOTE -** If the OAT sensor on an LDT unit fails, the controller will assume OAT is not suitable for HP and will use gas heat.

**Second Stage Heat -** Regardless of OD Temperature

- 7 - Second stage heat demand energizes W2 in the thermostat.
- 8 - See sequence of operation for gas heat.

**Defrost Mode:**

Defrost is enabled when outdoor coil temperature is below 35°F. The Unit Controller will cycle in and out of defrost depending on the temperature difference between the outdoor coil and outdoor air temperature. Defrost is also initiated when the accumulated run time with the outdoor coil temperature below 35°F reaches six hours.

**Note -** Only one refrigerant circuit will go into defrost at a time.

## DIRECT DRIVE BLOWER SEQUENCE OF OPERATION / TROUBLESHOOTING

### Blower Operation:

- 1 - Line voltage is routed to B3 blower motor through TB2 terminal strip, TB13 terminal strip and J/P48 terminals 1, 2 and 3.
- 2 - B3 blower motor runs internal diagnostics to check for proper temperature, voltage, etc. (KL2-2 and -3). This process takes approximately 10 seconds. Refer to the Failure Handling/Troubleshooting section.
- 3 - A55 Unit Controller receives a thermostat demand. After the A55 proves (P259-7 and -6) that B3 blower motor internal relay (KL2-2 and -3) is closed, B3 blower motor is energized (0-10VDC from P259-4 to KL3-4). B3 blower motor controls are grounded through KL2-2 and -3 to A55 P259-6.
- 4 - If configured, A55 checks S52 blower proving switch to make sure it closes within 16 seconds of the 0-10VDC signal being sent to B3 blower motor.

### Blower Fault Sequence Direct Drive Motor - No S52:

- 1 - Line voltage is provided to B3 blower motor.
- 2 - After 10 seconds, the B3 blower motor internal relay does not close.
- 3 - Alarm 186 is set by the A55 Unit Controller, de-energizing unit. If one of the "Error" failures listed in table 14 occurs ("Warning" failures will not set Alarm 186), service is required. Refer to the Failure Handling/Troubleshooting section.
- 4 - If B3 blower motor internal relay closes continue to next step.
- 5 - A55 sends 0-10VDC signal to B3 blower motor.
- 6 - During B3 blower motor operation, the internal motor relay opens.
- 7 - Alarm 186 is set by A55 and de-energizes the unit. Service is required. Refer to the Failure Handling/Troubleshooting section.

### Blower Fault Sequence Direct Drive Motor - With S52 (If Configured):

- 1 - A55 Unit Controller sends 0-10VDC signal to B3 blower motor.
- 2 - After 16 seconds, if S52 blower proving switch remains open, A55 will remove 0-10VDC signal for 5 minutes.
- 3 - A55 sends 0-10VDC signal to B3 blower motor.
- 4 - After 16 seconds, if S52 blower proving switch remains open, A55 will remove 0-10VDC signal for another 5 minutes.
- 5 - After the third try, A55 will de-energize the unit. Service is required.

### Failure Handling/Troubleshooting:

- 1 - Follow TABLE 12 to troubleshoot possible failures that would cause Alarm 186 to set.
- 2 - BEFORE DETERMINING THAT THE BLOWER ASSEMBLY HAS FAILED, use the A55 Unit Controller to clear delays and operate the blower.
- 3 - Main Menu > Service > Offline > Clear Delays > Yes > Save
- 4 - Main Menu > Service > Test > Blower
- 5 - Observe if the blower operates or if Alarm 186 sets again.
- 6 - If blower does not operate and Alarm 186 is set again, blower assembly must be replaced.
- 7 - If blower assembly does operate, wait a minimum of 30 minutes to ensure Alarm 186 is not set again.

**TABLE 12  
DIRECT DRIVE BLOWER MOTOR TROUBLESHOOTING**

| Failure                 | Error | Warning | Reason   | Troubleshoot   |
|-------------------------|-------|---------|--|--|
| Locked Rotor            | o     |         | No changes in hall signals within 2000ms                               | Check for obstruction keeping impeller from rotating   |
| Braking Mode            |       | o       | Warning, no error code set, Motor start not possible after 20 sec      | Check for secondary airflow source in the system causing the impeller to rotate backwards when off   |
| Hall Error              | o     |         | Combination of 3 hall signals gives false signal after one rotation    | Measure voltage across each leg, Check electrical connections  |
| Power Module Overheated | o     |         | Temperature > 115°C  | Check operating conditions in blower compartment, Check for high motor load (current draw), Check for corrosion-free and secure electrical connections |
| Motor Overheated        | o     |         | Motor over-temperature protector opens                                 |  |
| Gate Driver Error       | o     |         | Internal software fault  | Measure voltage across each leg, Check electrical connections  |
| Phase Failure           | o     |         | Input voltage has phase imbalance                                      | Measure voltage across each leg, Check electrical connections, Repair low/high voltage leg(s)  |
| DC Link Voltage Low     | o     |         | Rectified DC link voltage is too low                                   |  |
| DC Link Over-voltage    | o     |         | Rectified DC link voltage is too high                                  |  |
| Line Over-voltage       | o     |         | Line voltage too high  |  |
| Line Under-voltage      | o     |         | Line voltage too low   |  |
| Communication Error     |       |         | Internal communication failure. Not connected with master/slave wiring | Check low voltage wiring connections   |
| DC Link Voltage Low     |       | o       | Warning, not low enough to set error code                              | Measure voltage across each leg, Check electrical connections, Repair low/high voltage leg(s)  |
| Electronics Temp High   |       | o       | Warning, not high enough to set error code, Temperature > 95°C         | Check operating conditions in blower compartment, Check for high motor load (current draw), Check for corrosion-free and secure electrical connections |
| Power Module Temp High  |       | o       | Warning, not high enough to set error code, Temperature > 105°C        |  |
| Motor Temp High         |       | o       | Warning, not high enough to set error code, Temperature > 130°C        |  |

## VIII-Decommissioning

Before carrying out this procedure, it is essential that the technician is completely familiar with the equipment and all its detail. It is recommended good practice that all refrigerants are recovered safely. Prior to the task being carried out, an oil and refrigerant sample shall be taken in case analysis is required prior to re-use of recovered refrigerant. It is essential that electrical power is available before the task is commenced.

Steps to ensure this are:

- Become familiar with the equipment and its operation,
- Isolate the system electrically,
- Ensure that before attempting the procedure that mechanical handling equipment is available, if required, for handling refrigerant cylinders, and that all personal protective equipment is available and being used correctly while the recovery process is supervised at all times by a competent person and that the recovery equipment and cylinders conform to the appropriate standards.

Additionally, pump down refrigerant system, if possible, and if a vacuum is not possible, make a manifold so that refrigerant can be removed from various parts of the system. Make sure that cylinders are situated on the scales before recovery takes place. Start the recovery machine and operate in accordance with instructions. Do not overfill cylinders (no more than 80 % volume liquid charge). Do not exceed the maximum working pressure of the cylinder, even temporarily. When the cylinders have been filled correctly and the process completed, make sure that the cylinders and the equipment are removed from site promptly and all isolation valves on the equipment are closed off. Recovered refrigerant shall not be charged into another refrigerating system unless it has been cleaned and checked.

Equipment shall be labeled stating that it has been decommissioned and emptied of refrigerant. The label shall be dated and signed. For appliances containing flammable refrigerants, ensure that there are labels on the equipment stating the equipment contains flammable refrigerant.

Under no circumstances shall potential sources of ignition be used in the searching for or detection of refrigerant leaks. A halide torch (or any other detector using a naked flame) shall not be used. Electronic leak detectors may be used to detect refrigerant leaks but, in the case of flammable refrigerants, the sensitivity may not be adequate, or may need re-calibration. (Detection equipment shall be calibrated in a refrigerant-free area)

Ensure that the detector is not a potential source of ignition and is suitable for the refrigerant used. Leak detection equipment shall be set at a percentage of the LFL of the refrigerant and shall be calibrated to the refrigerant employed, and the appropriate percentage of gas (25 % maximum) is confirmed. Leak detection fluids are also suitable for use with most refrigerants but the use of detergents containing chlorine shall be avoided as the chlorine may react with the refrigerant and corrode the copper pipe-work. If a leak is suspected, all naked flames shall be removed/extinguished. If a leakage of refrigerant is found which requires brazing, all of the refrigerant shall be recovered from the system, or isolated (by means of shut off valves) in a part of the system remote from the leak.

When breaking into the refrigerant circuit to make repairs – or for any other purpose – conventional procedures shall be used. However, for flammable refrigerants it is important that best practice be followed, since flammability is a consideration. The following procedure shall be adhered to:

- Safely remove refrigerant following local and national regulations,
- Evacuate the circuit,
- Purge the circuit with inert gas,
- Evacuate,
- Purge with inert gas,
- Open the circuit.

The refrigerant charge shall be recovered into the correct recovery cylinders if venting is not allowed by local and national codes. For appliances containing flammable refrigerants, the system shall be purged with oxygen-free nitrogen to render the appliance safe for flammable refrigerants. This process might need to be repeated several times. Compressed air or oxygen shall not be used for purging refrigerant systems. Refrigerant purging shall be achieved by breaking the vacuum in the system with oxygen-free nitrogen and continuing to fill until the working pressure is achieved, then venting to atmosphere, and finally pulling down to a vacuum. This process shall be repeated until no refrigerant is within the system. When the final oxygen-free nitrogen charge is used, the system shall be vented down to atmospheric pressure to enable work to take place. Ensure that the outlet for the vacuum pump is not close to any potential ignition sources and that ventilation is available.