

LCX

XION™ ROOFTOP UNITS

Standard Efficiency | Lennox® CORE Lite Controller | Environ™ Coil | **R-454B** | 60Hz



COMMERCIAL PRODUCT SPECIFICATIONS (EHB)

2 to 6 Tons

Net Cooling Capacity - 23,600 to 68,000 Btu/h

Optional Electric Heat - 5 to 30 kW

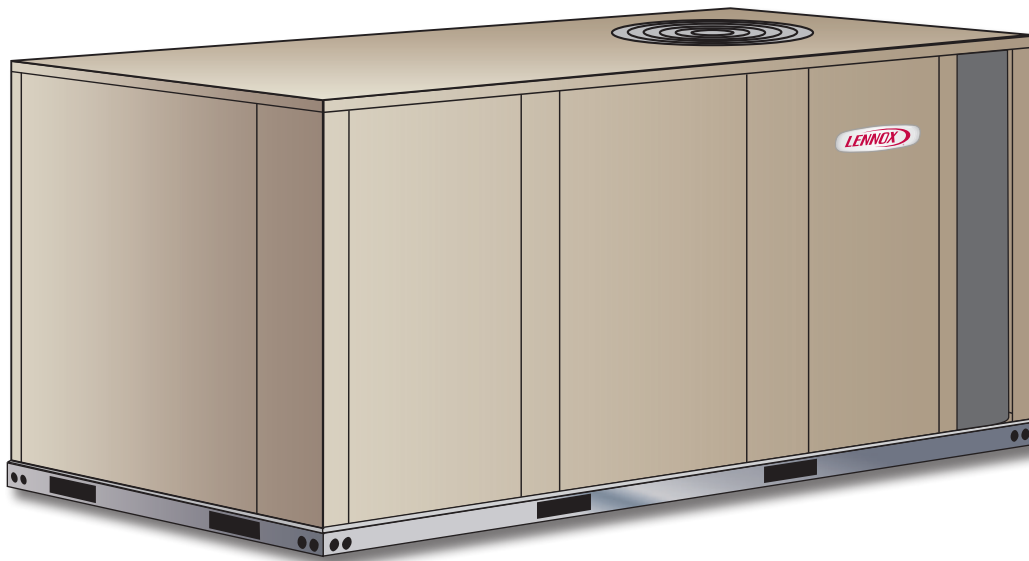

MODEL NUMBER IDENTIFICATION

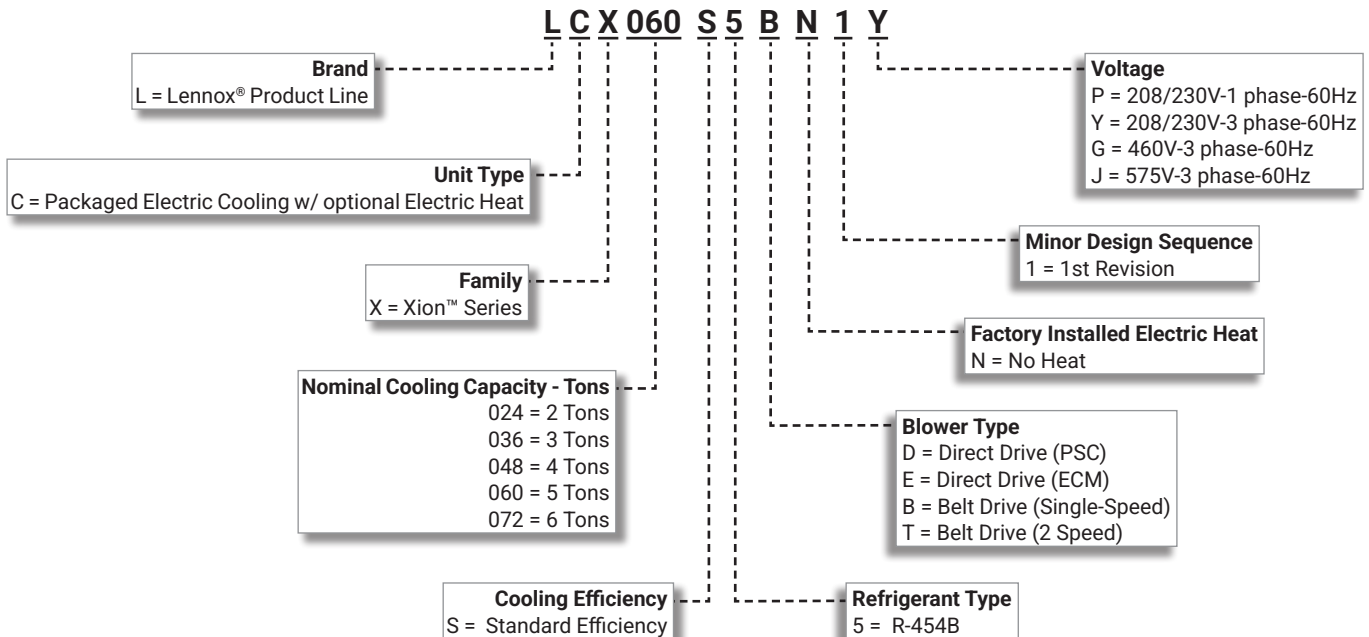

FEATURE HIGHLIGHTS

Xion™ rooftop units are engineered with the right technologies and options to meet standard efficiency requirements while delivering reliable performance and year-round comfort.

1. Scroll Compressor
2. Thermal Expansion Valves
3. Environ™ Coil System
4. Outdoor Coil Fan Motors
5. Heavy Gauge Steel Cabinet
6. Power Entry
7. Fully Insulated Cabinet
8. Hinged Access Panels (option)
9. Supply Air Blower
10. Electric Heat (option)
11. Air Filters
12. Lennox® CORE Lite Control System
13. Economizer (option)
14. Power Exhaust Fans (option)

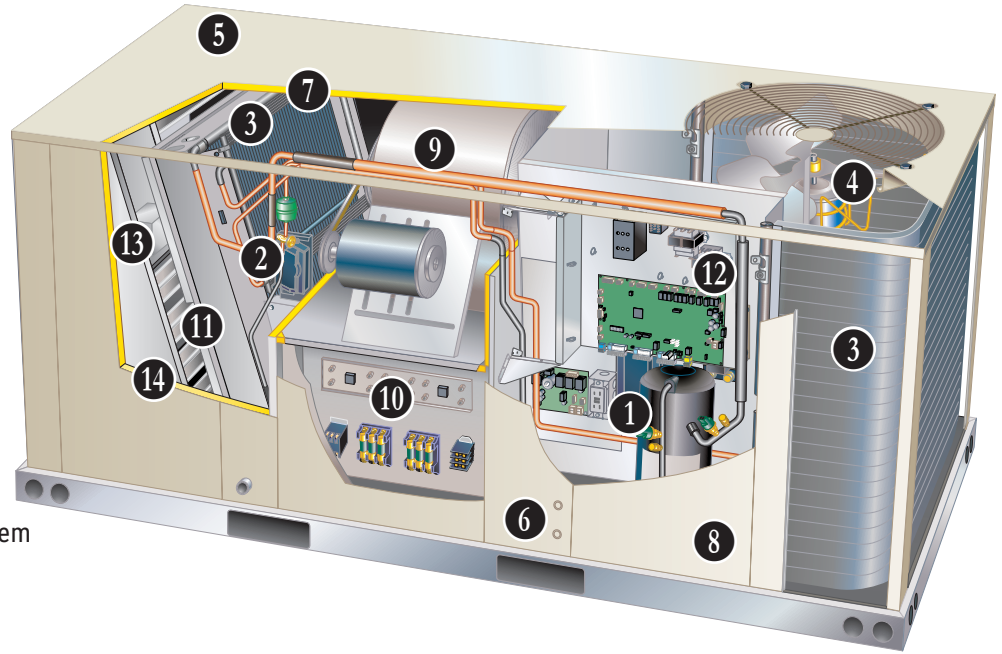

CONTENTS

Approvals And Warranty	3
Blower Data	26
Dimensions - Accessories	45
Dimensions - Unit	44
Electrical/Electric Heat Data	34
Electric Heat Capacities	42
Features And Benefits	3
Humiditrol® Dehumidification System Option	15
Humiditrol® Dehumidification System Ratings	24
Model Number Identification.	1
Optional Conventional Temperature Control Systems.	11
Options / Accessories	16
Outdoor Sound Data	33
Ratings	22
Sequence Of Operation.	13
Specifications - Belt Drive Blower	21
Specifications - Direct Drive Blower	19
Unit Clearances	42
Weight Data	43

APPROVALS AND WARRANTY

APPROVALS

- AHRI Standard 210/240-2023 certified (2 - 5 ton models)
- AHRI Standard 340/360-2023 certified (6 ton models)
- ETL and CSA listed
- Unit and components are ETL, NEC, and CEC bonded for grounding to meet safety standards for servicing
- All models are ASHRAE 90.1 compliant
- All models meet DOE 2023 energy efficiency standards and UL 60335-2-40 Refrigerant Detector Requirements
- All models have HCAI (formerly OSHPD) OSP and Special Seismic Certification ([Number: OSP-0596](#)), and meet 2021 International Building Code (IBC), 2022 California Building Code (CBC) ASCE 7, and ICC-ES AC156
- ISO 9001 Registered Manufacturing Quality System

WARRANTY

- Compressors - Limited five years
- Environ™ Coil System - Limited three years
- Lennox® CORE Lite Unit Controller - Limited three years
- High Performance Economizers (optional) - Limited five years
- All other covered components - Limited one year

FEATURES AND BENEFITS

COOLING SYSTEM

- Designed to maximize sensible and latent cooling performance at design conditions
- System can operate from 0°F to 125°F without any additional controls

R-454B Refrigerant

- Low GWP (Global Warming Potential)
- Zero ODP (Ozone Depletion Potential)
- Low Toxicity/Lower Flammability - A2L
- Unit is factory pre-charged

1 Single-Stage Scroll Compressor (024 through 060 Models)

- High performance, reliability and quiet operation
- Resiliently mounted on rubber grommets for quiet operation

Two-Stage Scroll Compressor (072 Models)

- Two-stage scroll compressors on all models for high performance, reliability, quiet operation, and increased part-load efficiency
- Resiliently mounted on rubber grommets for quiet operation

Compressor Crankcase Heater

- Protects against refrigerant migration that can occur during low ambient operation or during extended off cycles

2 Thermal Expansion Valve

- Ensures optimal performance throughout the application range
- Removeable element head

Filter/Drier

- High capacity filter/drier protects the system from dirt and moisture

High Pressure Switch

- Protects the compressor from overload conditions such as dirty condenser coils, blocked refrigerant flow or loss of outdoor fan operation

Low Pressure Switch

- Protects the compressor from low pressure conditions such as low refrigerant charge or low/no airflow

Indoor Coil Freeze Protection

- Protects the evaporator coil from damaging ice build-up due to conditions such as low/no air flow or low refrigerant charge

3 Environ™ Coil System

- Condenser and evaporator coil
- Lightweight, all aluminum brazed fin construction
- Constructed of three components:
 - A flat extrusion tube
 - Fins in-between the flat extrusion tube
 - Two refrigerant manifolds

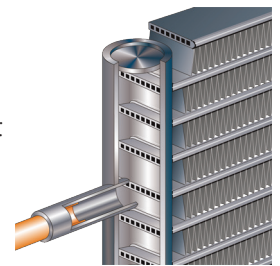

Environ™ Coil System Features:

- Improved heat transfer performance due to high primary surface area (flat tubes) versus secondary surface (fins)
- Smaller internal volume (reduced refrigerant charge)
- High durability
- All aluminum construction
- Fewer brazed joints
- Compact design
- Reduced unit weight
- Easy maintenance/cleaning
- Mounting brackets with rubber inserts secure coil to unit providing vibration dampening and corrosion protection

FEATURES AND BENEFITS

COOLING SYSTEM (continued)

Antimicrobial Condensate Drain Pan

- Composite pan, sloped to meet drainage requirements of ASHRAE 62.1
- Antimicrobial additive resists growth of mold and mildew on drain pan, which improves indoor air quality and reduces drain line blockage
- Side or bottom drain connections
- Reversible to allow connection at back of unit

4 Outdoor Coil Fan Motor

- Thermal overload protected
- Totally enclosed
- Permanently lubricated sleeve bearings
- Shaft up
- Wire basket mount

Outdoor Coil Fan

- PVC coated fan guard furnished

Low Ambient Switch (0°F)

- Cycles the outdoor fans while allowing compressor operation in the cooling cycle
- Intermittent fan operation allows the system to operate without icing the evaporator coil and losing capacity
- Designed for use in ambient temperatures no lower than 0°F

Required Selections

Cooling Capacity

- Specify nominal cooling capacity

Options/Accessories

Field Installed

Condensate Drain Trap

- Field installed only
- Available in copper or PVC

Drain Pan Overflow Switch

- Monitors condensate level in drain pan
- Shuts down unit if drain becomes clogged

LOW GWP REFRIGERANT DETECTION SYSTEM (RDS)

- Complies with UL 60335-2-40 approved standard
- Required for all systems using R-454B refrigerant
- Factory installed on all units
- Consists of a refrigerant detection sensor(s) and a mitigation control
- Ensures safe operation for systems equipped with R-454B refrigerant
- Sensor(s) monitors indoor coil area for R-454B refrigerant
- If R-454B refrigerant is detected the refrigerant detection system will prevent compressor and heating operation until R-454B refrigerant is no longer detected
- Refrigeration detection system energizes blower if any R-454B refrigerant is detected to mitigate any concentrations of refrigerant from the unit and the system

FEATURES AND BENEFITS

CABINET

5 Construction

- Heavy-gauge steel panels
- Full perimeter heavy-gauge galvanized steel base rail
- Base rails have rigging holes
- Three sides of the base rail have forklift slots
- Raised edges around duct and power entry openings in the bottom of the unit for water protection

Airflow Choice

- Units are shipped in downflow (vertical) return air configuration

NOTE - Can be field converted to horizontal airflow configuration without any optional kits.

6 Power Entry

- Electrical lines can be routed through the unit base or through horizontal access knock-outs

Exterior Panels

- Constructed of heavy-gauge, galvanized steel
- Textured pre-paint with polyurethane finish
- Cyclic salt fog and UV exposure up to 1,680 hours per ASTM D5894

7 Insulation

- Fully insulated with non-hygroscopic fiberglass insulation (conditioned areas)
- Unit base is fully insulated
- Base insulation serves as an air seal to the roof curb, eliminating the need to add a seal during installation

Access Panels

- Economizer/Filter section
- Heating/Blower section
- Compressor/Controls section

NOTE - Optional Economizers, Power Exhaust, Outdoor Air Dampers and Barometric Relief Dampers include a filler panel for proper cabinet fit.

Options/Accessories

Factory Installed

8 Hinged Access Panels

- Tool-Less access
- Economizer/Filter section
- Heating/Blower section
- Compressor/Controls section
- Panels seal and quarter-turn latching handles provide a tight air and water seal

Factory or Field Installed

Combination Coil/Hail Guards

- Heavy gauge steel frame
- Painted to match cabinet
- Expanded metal mesh protects outdoor coil

Burglar Bars

- Heavy gauge galvanized frame
- Fully welded
- 3/4 in. bar meets ASTM specification
- Frame meets ASTM A446, A525, A526 and A527 specification
- Burglar bars designed to fit ductwork

BLOWER

- A wide selection of supply air blower options are available to meet a variety of air flow requirements

Motor

- Overload protected
- Ball bearings (ECM and belt drive)
- Sleeve bearings (direct drive).
- Multi-tap direct drive PSC motors are available on 024, 036 and 048 models
- Variable-speed ECM direct drive motors are available on 036, 048 and 060 models
 - For ECM motors the amount of airflow for each stage can be set according to a parameter in the Lennox® CORE Lite Unit Controller
- Single-speed belt drive motor available on 060 models to maximize air performance at higher statics
- Two-speed belt drive motor furnished on 072 model

9 Supply Air Blower

- Forward curved blades
- Blower wheel statically and dynamically balanced
- Belt drive motors have adjustable pulley for speed change

Blower Proving Switch

- Monitors blower operation, shuts down unit if blower stops

Required Selections

Supply Air Blower

- Order direct drive or belt drive blower (See Blower Data Table for specifications)
- Belt Drive - Order drive kit, see Drive Kit Specifications Table

FEATURES AND BENEFITS

ELECTRICAL

- All units include terminal block and fuse block in power entry junction box for single power entry application

Marked & Color-Coded Wiring

- All electrical wiring is color-coded and marked to identify which components it is connecting

Electrical Plugs

- Positive connection electrical plugs are used to connect common accessories or maintenance parts for easy removal or installation

Required Selections

Voltage Choice

- Specify when ordering base unit

Options/Accessories

Factory or Field Installed

Disconnect Switch

- Accessible from outside of unit
- Spring loaded weatherproof cover furnished

GFI Service Outlets (2)

- 115V ground fault circuit interrupter (GFCI) type options:
 - Factory installed, non-powered, field wired
 - Field installed, non-powered, field wired

Field Installed

10 Electric Heat

- Helix wound nichrome elements
- Individual element limit controls
- Wiring harness
- Unit fuse block
- See Options / Accessories tables for ordering information

GFI Weatherproof Cover

- Single-gang cover
- Heavy-duty UV-resistant polycarbonate case construction
- Hinged base cover with gasket

INDOOR AIR QUALITY

11 Air Filters

- Disposable 2 inch MERV 4 filters furnished as standard

Options/Accessories

Field Installed

Healthy Climate® High Efficiency Air Filters

- Disposable MERV 8, MERV 13, or MERV 16 (Minimum Efficiency Reporting Value based on ASHRAE 52.2) efficiency 2 inch pleated filters

Replacement Filter Media Kit With Frame (072 Models)

- Replaces existing pleated filter media
- Includes washable metal mesh screen and metal frame with clip for holding replaceable non-pleated filter

Healthy Climate® UVC Germicidal Lamps

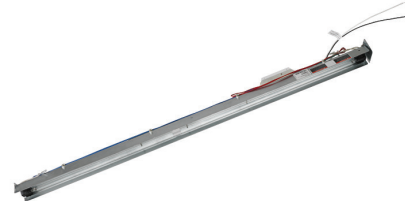

- Germicidal lamps emit ultra-violet (UV-C) energy, which has been proven to be effective in reducing microbes such as viruses, bacteria, yeasts, and molds
- UV-C energy greatly reduces the growth and proliferation of mold and other bioaerosols (bacteria and viruses) on illuminated surfaces (particularly coil and drain pan)
- Destroys the organism or controls its ability to reproduce
- Field installed in the blower/evaporator coil section
- Magnetic safety interlock terminates power when access panels are removed
- All necessary hardware for installation is included
- Lamps operate on 110/230V-1ph power supply
- **NOTE** - Step-down transformer may be ordered separately for 460V and 575V units.
- Approved by ETL

Needlepoint Bipolar Ionization (NPBI) Kit

- NPI technology has been shown to effectively reduce harmful pathogens, pollutants, and odors
- Brush-type ionizer introduces a high concentration of both positive and negative ions into the air stream
- These bipolar ions are then dispersed into the occupied space through the duct system proactively reducing the airborne contaminants
- Ions travel within the building air stream and attach to particles, pathogens, and gas molecules, making them larger and easier to capture in the filtration system
- UL 2998 certified for zero ozone emission

Indoor Air Quality (CO₂) Sensors

- Monitors CO₂ levels
- Reports to the Lennox® CORE Lite Unit Controller, which adjusts economizer dampers as needed

CONTROL SYSTEM

LENNOX® CORE LITE CONTROL SYSTEM

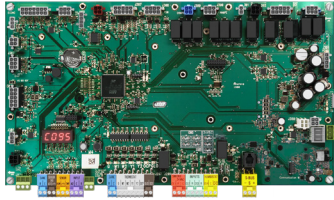

- 12** The Lennox® CORE Lite Control system is designed to accelerate equipment install and service. Standard with all Xion™ rooftop units, control system integrates key technologies that lower installation costs, drive system efficiency, and protect your investments.

The Lennox® CORE Lite Unit Controller is a microprocessor-based controller that provides flexible control of all unit functions.

CORE Mobile Service App

- Guided Setup with progress indicators, detailed help, and exportable summaries to manage simple, trouble-free setup, reducing commissioning times
- Enhanced Test Functionality provides real-time sensor readings, trending, and reports that enable easy troubleshooting
- Ability to set and configure parameters of the CORE Control System to manage sequence of operation
- Economizer test function ensures economizer is operating correctly



Additional Features:

- Built-In 7-Segment Display shows Unit Status and active alarms for easy troubleshooting
- Buttons for test and clearing delays
- SmartWire™ System with keyed and removable screw terminals ensure correct field wiring
- Profile setup copies key settings between units with the same configuration to reduce setup time
- USB port allows a technician to download and transfer unit information to help verify service was performed
- USB software updates on the Lennox® CORE Lite Unit Controller enhance functionality without the need to change components

Configurable Built-In Functions

- Up to three distinct Cooling Airflows in Thermostat Mode
- Programmable independent heating, ventilation and cooling blower speeds
- Economizer Control Options (See Economizer / Exhaust Air / Outdoor Air sections)
- Exhaust Fan Control Modes for fresh air damper position
- Configurable Morning Warm-up
- Night Setback Mode
- Demand Control Ventilation
- Humiditrol® Operation

Component Protection / Unit Safeguards:

- Compressor Time-Off Delay
- Adjustable Blower On/Off Delay
- Return Air Temperature Limit Control
- Safety Switch Input allows Controller to respond to a external safety switch trip
- Service Relay Output
- Thermostat Bounce Delay
- Smoke Alarm Mode has four choices (unit off, positive pressure, negative pressure, purge)
- “Strike Three” Protection
- Gas Valve Time Delay Between First and Second Stage
- Minimum Compressor Run Time

Control Methods / Interfaces:

- DDC and 24V Thermostat
- BACnet MS/TP (Field Option)
- Zone Temperature Sensor Input
- Dehumidistat and Humidity Sensor Inputs
- Indoor Air Quality Inputs (2)
- Built-in Control Parameter Defaults
- Permanent Diagnostic Code Storage
- Field Adjustable Control Parameters (Over 100 settings)
- Multiple Configurable Digital Inputs
- LED Indicators

NOTE - Lennox® CORE Control System features vary with the type of rooftop unit in which the control is installed.

CONTROL SYSTEM

LENNOX® CORE LITE CONTROL SYSTEM (CONTINUED)

Controls Options

Field Installed

Dirty Filter Switch

- Senses static pressure increase and issues alarm if necessary

Smoke Detector

- Photoelectric type
- Installed in supply air section, return air section or both sections
- Available with power board and single sensor (supply or return) or power board and two sensors (supply and return)
- Power board located in unit control compartment

Commercial Control Systems

Field Installed

Interoperability via BACnet® Protocols

- Communication compatible with third-party automation systems that support the BACnet Application Specific Controller device profile

Thermostats and Room Sensors

- Control system and thermostat options, see page 11

OPTIONS / ACCESSORIES

ECONOMIZER

- 13 • Economizer operation is set and controlled by the Lennox® CORE Lite Unit Controller
- Simple plug-in connections from economizer to unit controller for easy installation
- All Xion™ rooftop units are equipped with factory installed CEC Title 24 approved sensors for outside, return and discharge air temperature monitoring

NOTE - Optional sensors may be used instead of unit sensors to determine whether outdoor air is suitable for free cooling. See Options/Accessories table.

Factory or Field Installed

High Performance Economizer

- Approved for California Title 24 building standards
- Low leakage dampers are Air Movement and Control Association International (AMCA) Class 1A Certified - Maximum 3 CFM per sq. ft. leakage at 1 in. w.g.
- ASHRAE 90.1 compliant
- Combination Outdoor Air Hood is furnished
- Factory installed Economizer can be ordered with three exhaust options:
 - Barometric Relief Dampers
 - Power Exhaust Fan

NOTE - See Power Exhaust Fan section for additional requirements.

- No Exhaust
- Field installed Economizer includes Barometric Relief Dampers with Combination Hood
- Barometric Relief Dampers allow relief of excess air
- Dampers prevent blow back and outdoor air infiltration during off cycle
- Bird screen furnished

NOTE - Barometric Relief Dampers are required when Economizer is factory installed with factory installed Power Exhaust Fan option. See Power Exhaust Fan section and Options/Accessories table.

- Demand Control Ventilation (DCV) ready using optional CO₂ sensors
- Horizontal Barometric Dampers are required for horizontal Economizer applications and must be ordered separately
- Linked damper action
- High torque 24-volt fully-modulating spring return damper motor
- Return air and outdoor air dampers
- Plug-in connections to unit

OPTIONS/ACCESSORIES

ECONOMIZER (continued)

Factory or Field Installed (continued)

NOTE - High Performance Economizers are not approved for use with enthalpy controls in Title 24 applications.

NOTE - The Free Cooling setpoint for Title 24 applications must be set based on the Climate Zone where the system is installed. See Section 140.4 "Prescriptive Requirements for Space Conditioning Systems" of the California Energy Commission's 2022 Building Energy Efficiency Standards.

NOTE - Refer to Installation Instructions for complete setup information.

Single Enthalpy Temperature Control (Not for Title 24)

- Outdoor air enthalpy sensor enables Economizer if the outdoor enthalpy is less than the setpoint of the control

Field Installed

Differential Enthalpy Control (Not for Title 24)

- Order two Single Enthalpy Controls:
 - One is field installed in the return air section
 - One in the outdoor air section
- Allows the economizer control to select between outdoor air or return air, whichever has lower enthalpy

Horizontal Barometric Relief Dampers

- For use when unit is configured for horizontal applications with an economizer
- Allows relief of excess air
- Blade type dampers prevent blow back and outdoor air infiltration during off cycle
- Field installed in return air duct
- Exhaust hood with bird screen furnished
- Requires Horizontal Economizer Conversion Kit

Horizontal Economizer Conversion Kit

- Insulated panel covers the bottom return air opening on the unit base to convert downflow economizer to horizontal air flow

EXHAUST

Field Installed

14 Power Exhaust Fan

- Installs internal to unit for downflow applications only with economizer option
- Provides exhaust air pressure relief
- Interlocked to run when supply air blower is operating
- Fan runs when outdoor air dampers are 50% open (adjustable)
- Motor is overload protected
- Fan is 16 in. diameter
- Four blades
- One 1/3 HP motor

NOTE - If Power Exhaust is field installed with a factory installed Economizer, the Economizer must be ordered with No Exhaust option. Barometric Relief Dampers must also be ordered separately for field installation.

NOTE - If Power Exhaust is factory installed with a factory installed Economizer, Barometric Relief Dampers must also be ordered separately for field installation.

OUTDOOR AIR

Field Installed

Outdoor Air Damper

- Downflow or Horizontal
- Linked mechanical dampers
- 0 to 25% (fixed) outdoor air adjustable
- Installs in unit
- Includes outdoor air hood
- Motorized model features fully modulating spring return damper motor with plug-in connection
- Manual model features parallel blade, gear-driven dampers with adjustable fixed position

OPTIONS/ACCESSORIES

ROOF CURBS

Field Installed

- Nailer strip furnished (downflow only)
- Mates to unit
- US National Roofing Contractors Approved
- Shipped knocked down

Hybrid Roof Curbs, Downflow

- Interlocking tabs fasten corners together
- No tools required for assembly
- Can also be fastened together with furnished hardware
- Available in 8, 14, 18, and 24 inch heights

Adjustable Pitch Curb

- Fully adjustable pitch curbs (3/4 in. per foot in any direction) provide a level platform for rooftop units allowing flexible installations on roofs with uneven or sloped angles
- Interlocking tabs fasten corners together
- No tools required for assembly
- Hardware is furnished to connect upper curb with lower curb
- Available in 14 inch height

Adaptor Curbs (not shown)

- Curbs are regionally sourced
- Dimensions vary based upon the source

NOTE - Contact your local sales representative for a detailed cut sheet with applicable dimensions.

CEILING DIFFUSERS

Field Installed

Ceiling Diffusers

(Flush or Step-Down)

- White powder coat finish on diffuser face and grilles
- Insulated UL listed duct liner
- Diffuser box has collars for duct connection
- Step-down diffusers have double deflection blades
- Flush diffusers have fixed blades
- Provisions for suspending
- Internally sealed to prevent recirculation
- Removable return air grille
- Adapts to T-bar ceiling grids or plaster ceilings

Transitions (Supply and Return)

- Used with diffusers
- Installs in roof curb
- Galvanized steel construction
- Flanges furnished for duct connection to diffusers
- Fully insulated

OPTIONAL CONVENTIONAL TEMPERATURE CONTROL SYSTEMS

CS8500 Commercial 7-Day Programmable Thermostat

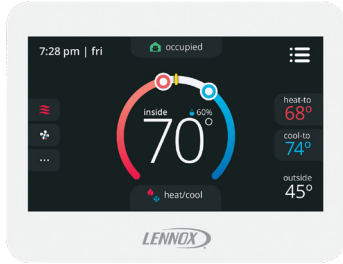

- Fully Communicating Sensor
- Full Color Touchscreen Interface
- Variable Speed System Control (On Compatible Units)
- Up To 4 Heat / 4 Cool
- Built-In Sensors For Temperature, Humidity And Optional CO₂
- Remote Sensor Options For Occupancy, Temperature
- BACnet Capable Options
- 5-2 or 7-Day Scheduling
- Smooth Setback Recovery
- Heat/Cool Auto-Changeover
- Four-Wire Installation
- FDD, ASHRAE, IECC Compliant

CS7500 Commercial 7-Day Programmable Thermostat



- Premium Universal Thermostat
- Full Color Touchscreen Interface
- Up To 4 Heat / 3 Cool
- Built-In Sensors For Temperature and Humidity
- Remote Sensors Options For Temperature, Discharge Air, Outdoor Air
- 5-2 or 7-Day Scheduling
- Smooth Setback Recovery
- Heat/Cool Auto-Changeover
- FDD, ASHRAE, IECC Compliant

CS3000 Commercial 5-2 Day Programmable Thermostat

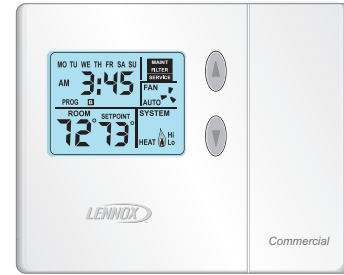

- Conventional Multi-Stage Thermostat
- Intuitive Display
- Push-Button Operation
- Up To 2 Heat / 2 Cool
- Built-In Temperature Sensor
- Remote Temperature Sensing
- Up to 5-2 Day Scheduling
- Smooth Setback Recovery
- Heat/Cool Auto-changeover

Wired Temperature/Humidity Room Sensor (Non-Communicating)



- Terminal blocks for wiring connections
- Five-wire sensor connection
- Off-white plastic enclosure
- Non-adjustable
- Relative humidity range: 0 -100%
- +/- 3% Accuracy

OPTIONAL CONVENTIONAL TEMPERATURE CONTROL SYSTEMS

Description	Order Number
CS8500 Commercial 7 Day Programmable Thermostat	
CS8500 7-Day Thermostat	No CO ₂ Sensing 24K55
	With CO ₂ Sensing 24K53
Sensors/Accessories	¹ Remote non-adjustable wall-mount 10k 47W37
	¹ Remote non-adjustable wall-mount 11k 94L61
CS7500 Commercial 7-Day Programmable Thermostat	
CS7500 7-Day Thermostat	24K41
Sensors/Accessories	² Remote non-adjustable wall-mount 20k 47W36
	² Remote non-adjustable wall-mount 10k 47W37
	Remote non-adjustable discharge air (duct mount) 19L22
	Outdoor temperature sensor X2658
CS3000 Commercial 5-2 Day Programmable Thermostat	
CS3000 5-2 Day Thermostat	11Y05
Sensors/Accessories	Remote non-adjustable wall mount 10k averaging 47W37
	Thermostat wall mounting plate X2659
Universal Thermostat Guard with Lock (clear)	
	Inside Dimensions (H x W x D) 5-7/8 x 8-3/8 x 3 in. 39P21
Temperature/Humidity Room Sensor	
A335MT13AE1 Wired Temperature/Humidity Room Sensor (Non-Communicating)	21W06

¹ Up to nine of the same type remote temperature sensors can be connected in parallel.

² Remote wall-mount sensors can be applied in any of the following combinations:

One Sensor - (1) 47W36, Two Sensors - (2) 47W37, Three Sensors - (2) 47W36 and (1) 47W37

Four Sensors - (4) 47W36, Five Sensors - (3) 47W36 and (2) 47W37

SEQUENCE OF OPERATION - 6 TON MODELS

Objective: Outline the unit functions as a result of room thermostat or zone sensor demands.

Given: When economizer is present, it will function as initial part of the unit cooling system. When not present, unit will function as if outdoor ambient is high and sensed as not suitable.

Modulating Outdoor Air Damper:

Damper minimum positions #1 and 2 are adjusted during unit setup to provide minimum fresh air requirements at the indicated supply fan speeds per ASHRAE 62.1.

- Supply fan is off and the outdoor air damper is closed
- Supply fan is on low speed and the outdoor air damper is at minimum position 1
- Supply fan is on high speed and the outdoor air damper is at minimum position 2

¹ Unit Features an Economizer and Outdoor Air is Suitable

Cooling - Thermostat or Zone Sensor Mode (Up to 2 stages Y1, Y2)

Y1 Demand:

Compressor is off, supply fan is on low speed, economizer modulates (minimum to maximum open position) to maintain 55°F supply air temperature (default unit controller setting)

After 5 minutes (default unit controller setting), supply fan switches to high speed. Economizer continues modulating with supply fan on high speed to maintain 55°F supply air temperature

Y2 Demand:

Compressor is off, supply fan is on high speed, and economizer modulates to maintain 55°F supply air temperature

Economizer opens to maximum. If economizer stays at maximum open for 3 minutes (default unit controller setting) compressor is energized and operates at first stage while supply fan stays on high speed

Y3 Demand:

Economizer is at maximum open and compressor operates at first stage. If economizer stays at maximum open for 3 minutes (default unit controller setting) compressor switches to second stage operation while supply fan stays on high speed

¹ Outdoor air suitability is determined by the energy state of outdoor ambient (enthalpy or sensible) and its ability to achieve the desired free cooling effects. Outdoor air suitability can also be determined by a third party controller and provided to the RTU via a network connection.

Unit Does Not Feature an Economizer (or Outdoor Air Is Not Suitable)

Cooling - Thermostat or Zone Sensor (Up to 2 stages Y1, Y2)

Y1 Demand:

Compressor operates at first stage and supply fan operates at low speed

Y2 Demand:

Compressor operates at second stage and supply fan operates at high speed

(Continued on Next Page)

SEQUENCE OF OPERATION - 6 TON MODELS

Dehumidification Mode (economizer free cooling is locked out):

Unit Features the Humiditrol® Dehumidification option.

No Y1, Y2 Demand but a call for dehumidification:

Compressor operates at second stage, supply fan operates at low speed, and the reheat valve is energized

Y1 Demand:

Compressor operates at second stage, supply fan operates at low speed and the reheat valve is de-energized

Y2 Demand:

Compressor operates at second stage, supply fan operates at high speed, and the reheat valve is de-energized

Heating Mode: Thermostat or Zone Sensor (1 stage W1)

W1 Demand:

Electric Heat is energized and the supply fan operates at high speed

HUMIDITROL® DEHUMIDIFICATION SYSTEM OPTION

OVERVIEW

- Factory installed option designed to control humidity
- Provides dehumidification on demand using ASHRAE 90.1 recommended method for comfort conditioning humidity controller
- Unit comes equipped with one row reheat coil, solenoid valve and humidity controller
- Reheat controls are located in the compressor control section of the unit for easy access

BENEFITS

- Improves indoor air quality
- Helps prevent damage due to high humidity levels
- Improves comfort levels by reducing space humidity levels

OPERATION

No Dehumidification Demand

- Unit will operate conventionally whenever there is a demand for cooling or heating and no dehumidification demand
- Free cooling is only permitted when there is no demand for dehumidification

Dehumidification Demand Only

- Reheat operation will initiate on a dehumidification demand and does not require a cooling demand
- Unit will operate in the dehumidification mode until the relative humidity of the conditioned space is below the setpoint
- Reheat coil is sized to provide 68°F to 75°F supply air during reheat operation
- This reduces sensible cooling capacity and extends compressor run time to control humidity when the cooling load is low
- A solenoid valve diverts hot gas from the compressor to the reheat coil

- Cooled and dehumidified air from the evaporator is reheated as it passes through the reheat coil
- De-superheated and partially condensed refrigerant continues to the outdoor condenser coil where condensing is completed
- Unit will continue to operate in this mode until the dehumidification demand is satisfied

Dehumidification and Cooling Demand (Thermostat/ Room Sensor Application)

Single speed compressor model (024 through 060)

- A two stage thermostat is required for dehumidification to operate with a single speed system
- If both a dehumidification and a Y1 cooling demand occur, the system will ignore the Y1 demand and continue to operate in dehumidification mode until the humidity setpoint is reached
- A Y2 demand will shut off dehumidification mode and normal cooling will resume until demand is satisfied

Two-stage compressor models (072)

- A dehumidification demand sends both the blower (if T type blower is selected) and compressor to high speed
- If both a dehumidification and a Y1 cooling demand occur, the system will ignore the Y1 demand and continue to operate in dehumidification mode
- If a Y2 cooling demand occurs along with a dehumidification demand, the system operates in full cooling mode at full cooling airflow until the Y2 cooling demand is satisfied
- Then the system will revert to the dehumidification mode if a dehumidification mode demand is present

TYPICAL DEHUMIDIFICATION SCHEMATIC

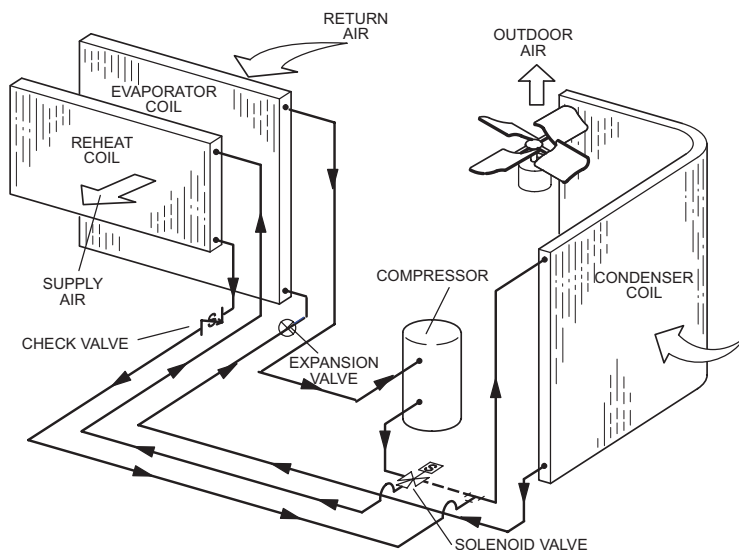

OPTIONS / ACCESSORIES

Item	Order Number	Size					
		024	036	048	060	072	
COOLING SYSTEM							
Condensate Drain Trap	PVC	22H54	X	X	X	X	X
	Copper	76W27	X	X	X	X	X
Drain Pan Overflow Switch		21Z07	X	X	X	X	X
BLOWER - SUPPLY AIR							
Motors	Direct Drive (PSC) - 0.25 HP (208/230V-1ph)	Factory	O				
	Direct Drive (PSC) - 0.50 HP (All Voltages)	Factory		O	O		
	Direct Drive (ECM) - 1.0 HP (All Voltages)	Factory		O	O	O	
	Single-Speed Belt Drive - 2 HP (208/230V, 460V, 575V-3ph)	Factory				O	
	Two-Speed Belt Drive - 2 HP (208/230V, 460V, 575V-3ph)	Factory					O
Drive Kits See Blower Data Tables for selection	Kit A04 - 968-1340 rpm	Factory					O
	Kit A07 - 1212-1548 rpm	Factory				O	
	Kit A08 - 1193-1591 rpm	Factory					O
CABINET							
Burglar Bars		Y1037	X	X	X	X	X
Combination Coil/Hail Guards		13R98	OX	OX	OX	OX	
		13T03					OX
Hinged Access Panels			O	O	O	O	O
CONTROLS							
BACnet® Module		38B35	X	X	X	X	X
Dirty Filter Switch		53W66	X	X	X	X	X
Smoke Detector - Supply or Return (Power board and one sensor)		21Z11	X	X	X	X	X
Smoke Detector - Supply and Return (Power board and two sensors)		21Z12	X	X	X	X	X
ELECTRICAL							
Voltage 60 Hz	208/230V - 1 phase		O	O	O	O	
	208/230V - 3 phase			O	O	O	O
	460V - 3 phase			O	O	O	O
	575V - 3 phase			O	O	O	O
Disconnect	See Electrical/Electric Heat Tables for selection		OX	OX	OX	OX	OX
GFI Service Outlets	15 amp non-powered, field-wired (208/230V, 460V only)	74M70	OX	OX	OX	OX	OX
	² 20 amp non-powered, field-wired (208/230V, 460V, 575V)	67E01	X	X	X	X	X
	² 20 amp non-powered, field-wired (575V)	Factory	O	O	O	O	O
Weatherproof Cover for GFI		10C89	X	X	X	X	X

¹ Required if Humiditrol® Dehumidification System is ordered.

² Canada requires a minimum 20 amp circuit. Select 20 amp, non-powered, field wired GFI.

NOTE - Order numbers shown are for ordering optional accessories if a field installed option is available.

OX - Field Installed or Configure to Order (factory installed)

O - Configure to Order (Factory Installed)

X - Field Installed

OPTIONS / ACCESSORIES

Item	Order Number	Size				
		024	036	048	060	072
ELECTRIC HEAT						
5 kW	208/240V- 1ph	31B27	X			
7.5 kW	208/240V-1ph	24U10	X	X	X	X
	208/240V-3ph	24U11		X	X	X
	460V-3ph	24U12		X	X	X
	575V-3ph	24U13		X	X	X
10 kW	208/240V-1ph	24U14	X			
15 kW	208/240V-1ph	24U15		X	X	X
	208/240V-3ph	24U16		X	X	X
	460V-3ph	24U17		X	X	X
	575V-3ph	24U18		X	X	X
22.5 kW	208/240V-1ph	24U19				X
	208/240V-3ph	24U20				X
	460V-3ph	24U21				X
	575V-3ph	24U22				X
30 kW	208/240V-3ph	24U23				X
	460V-3ph	24U24				X
	575V-3ph	24U25				X

ECONOMIZER

High Performance Economizer With Combination Outdoor Air Hood (Sensible Control) (Approved for California Title 24 Building Standards / AMCA Class 1A Certified)

Includes Barometric Relief Dampers and Combination Hood	20H48	OX	OX	OX	OX	OX
---	--------------	----	----	----	----	----

Economizer Accessories

Horizontal Economizer Conversion Kit	17W45	X	X	X	X	X
--------------------------------------	--------------	---	---	---	---	---

Economizer Controls

Single Enthalpy Control	21Z09	OX	OX	OX	OX	OX
Differential Enthalpy Control (order 2) (Not for Title 24)	21Z09	X	X	X	X	X

POWER EXHAUST FAN

Standard Static	208/230V-1 or 3ph	21Z13	X	X	X	X	X
<i>NOTE - Field installed Power Exhaust Fan requires "Barometric Relief Dampers for Power Exhaust Kit" for field installation. See below.</i>	460V-3ph	21Z14		X	X	X	X
	575V-3ph	21Z15		X	X	X	X

BAROMETRIC RELIEF

³ Barometric Relief Dampers for Power Exhaust Kit	21Z21		X	X	X	X
⁴ Horizontal Barometric Relief Dampers With Exhaust Hood	19F01	X	X	X	X	X

³ Required when Economizer is factory installed with field installed Power Exhaust Fan option.

⁴ Required when Economizer is configured for horizontal airflow.

NOTE - Order numbers shown are for ordering optional accessories if a field installed option is available.

OX - Field Installed or Configure to Order (factory installed)

O - Configure to Order (Factory Installed)

X - Field Installed

OPTIONS / ACCESSORIES

Item	Order Number	Size				
		024	036	048	060	072
OUTDOOR AIR						
Outdoor Air Dampers With Outdoor Air Hood						
Motorized	15D17	X	X	X	X	X
Manual	15D18	X	X	X	X	X
HUMIDITROL® DEHUMIDIFICATION REHEAT OPTION						
Humiditrol Dehumidification Option	Factory	O	O	O	O	O
INDOOR AIR QUALITY						
Air Filters						
Healthy Climate® High Efficiency Air Filters	MERV 8 (16 x 20 x 2)	54W20	X	X	X	X
	MERV 13 (16 x 20 x 2)	52W37	X	X	X	X
Order 4 per unit	MERV 16 (16 x 20 x 2)	22H13	X	X	X	X
	MERV 8 (20 x 20 x 2)	54W21				X
	MERV 13 (20 x 20 x 2)	52W39				X
	MERV 16 (20 x 20 x 2)	21U40				X
Replaceable Media Filter With Metal Mesh Frame (includes non-pleated filter media) (Order 4 per unit)	(20 x 20 x 2)	44N60				X
Indoor Air Quality (CO₂) Sensors						
Sensor - Wall-mount, off-white plastic cover with LCD display		77N39	X	X	X	X
Sensor - Wall-mount, off-white plastic cover, no display		87N53	X	X	X	X
Sensor - Black plastic case, LCD display, rated for plenum mounting		87N52	X	X	X	X
Sensor - Black plastic case, no display, rated for plenum mounting		87N54	X	X	X	X
CO ₂ Sensor Duct Mounting Kit - for downflow applications		23Y47	X	X	X	X
Aspiration Box - for duct mounting non-plenum rated CO ₂ sensor (77N39)		90N43	X	X	X	X
Needlepoint Bipolar Ionization (NPBI)						
Needlepoint Bipolar Ionization Kit		21U35	X	X	X	X
UVC Germicidal Lamps						
⁵ Healthy Climate® UVC Light Kit (110/230V-1ph)		21A92	X	X	X	X
Step-Down Transformers	460V primary, 230V secondary	10H20	X	X	X	X
	575V primary, 230V secondary	10H21	X	X	X	X
ROOF CURBS						
Hybrid Roof Curbs, Downflow						
8 in. height		11F50	X	X	X	X
14 in. height		11F51	X	X	X	X
18 in. height		11F52	X	X	X	X
24 in. height		11F53	X	X	X	X
Adjustable Pitch Curb						
14 in. height		43W27	X	X	X	X
CEILING DIFFUSERS						
Step-Down - Order one	RTD9-65S	13K60	X	X	X	X
	RTD11-95S	13K61				X
Flush - Order one	FD9-65S	13K55	X	X	X	X
	FD11-95S	13K56				X
Transitions (Supply and Return) - Order one	T1TRAN10AN1	17W53	X	X	X	X
	T1TRAN20N-1	17W54				X

⁵ Lamps operate on 110-230V single-phase power supply. Step-down transformer may be ordered separately for 460V and 575V units. Alternately, 110V power supply may be used to directly power the UVC ballast(s).

NOTE - Order numbers shown are for ordering optional accessories if a field installed option is available.

OX - Field Installed or Configure to Order (factory installed)

O - Configure to Order (Factory Installed)

X - Field Installed

SPECIFICATIONS - DIRECT DRIVE BLOWER		2 TON 3 TON		
Model		LCX024S5D	LCX036S5D	LCX036S5E
Nominal Tonnage		2	3	3
Efficiency Type		Standard	Standard	Standard
Blower Type		Multi-Tap Direct Drive	Multi-Tap Direct Drive	Variable-Speed Direct Drive
Cooling Performance	Gross Cooling Capacity (Btuh)	24,600	37,300	37,300
	¹ Net Cooling Capacity (Btuh)	23,600	35,600	35,600
	¹ AHRI Rated Air Flow (cfm)	850	1200	1200
	¹ SEER2 (Btuh/Watt)	14.0	14.0	14.0
	¹ EER2 (Btuh/Watt)	11.5	11.5	11.5
	Total Unit Power (kW)	1.9	3.0	3.0
Sound Rating Number	dBA	74	74	74
Refrigerant Charge	Refrigerant Type	R-454B	R-454B	R-454B
	Without Reheat Option	3 lbs. 14 oz.	3 lbs. 11 oz.	3 lbs. 11 oz.
	With Reheat Option	4 lbs. 10 oz.	4 lbs. 10 oz.	4 lbs. 10 oz.
Electric Heat Available		See page 42		
Compressor Type (Number)		Scroll (1)	Scroll (1)	Scroll (1)
Outdoor Coil	Net face area - ft. ²	11.7	11.7	11.7
	Rows	1	1	1
	Fins - in.	23	23	23
Outdoor Coil Fan	Motor HP (number and type)	1/4 (1 PSC)	1/4 (1 PSC)	1/4 (1 PSC)
	Rpm	825	825	825
	Watts	325	325	325
	Diameter (Number) - in.	(1) 24	(1) 24	(1) 24
	Blades	4	4	4
	Total air volume - cfm	3950	3950	3950
Indoor Coil	Net face area - ft. ²	7.0	7.0	7.0
	Rows	1	1	1
	Fins - in.	20	20	20
	Condensate drain size (NPT) - in.	(1) 1	(1) 1	(1) 1
	Expansion device type	Balanced Port Thermostatic Expansion Valve removable power head		
Indoor Blower	Blower Type	PSC	PSC	ECM
	Nominal Motor HP	0.25	0.5	1
	Wheel (Number) diameter x width - in.	(1) 10 x 10	(1) 10 x 10	(1) 11 x 10
Filters	Type	MERV 4, Disposable		
	Number and size - in.	(4) 16 x 20 x 2		
Line voltage data (Volts-Phase-Hz)		208/230-1-60	208/230-1-60 208/230-3-60 460-3-60 575-3-60	208/230-1-60 208/230-3-60 460-3-60 575-3-60

NOTE - Net capacity includes evaporator blower motor heat deduction. Gross capacity does not include evaporator blower motor heat deduction.

¹ AHRI Certified to AHRI Standard 210/240: 95°F outdoor air temperature and 80°F db/67°F wb entering evaporator air; minimum external duct static pressure.

SPECIFICATIONS - DIRECT DRIVE BLOWER		4 TON 5 TON		
Model		LCX048S5D	LCX048S5E	LCX060S5E
Nominal Tonnage		4	4	5
Efficiency Type		Standard	Standard	Standard
Blower Type		Multi-Tap Direct Drive	Variable-Speed Direct Drive	Variable-Speed Direct Drive
Cooling Performance	Gross Cooling Capacity (Btuh)	49,700	49,700	60,900
	¹ Net Cooling Capacity (Btuh)	47,000	47,000	58,000
	¹ AHRI Rated Air Flow (cfm)	1700	1700	1900
	¹ SEER2 (Btuh/Watt)	14.0	14.0	14.0
	¹ EER2 (Btuh/Watt)	11.5	11.5	11.5
	Total Unit Power (kW)	4.1	4.1	5.0
Sound Rating Number	dBA	74	74	74
Refrigerant Charge	Refrigerant Type	R-454B	R-454B	R-454B
	Without Reheat Option	3 lbs. 8 oz.	3 lbs. 8 oz.	3 lbs. 12 oz.
	With Reheat Option	4 lbs. 4 oz.	4 lbs. 4 oz.	4 lbs. 12 oz.
Electric Heat Available		See page 42		
Compressor Type (Number)		Scroll (1)	Scroll (1)	Scroll (1)
Outdoor Coil	Net face area - ft. ²	14.5	14.5	14.5
	Rows	1	1	1
	Fins - in.	23	23	23
Outdoor Coil Fan	Motor HP (number and type)	1/4 (1 PSC)	1/4 (1 PSC)	1/4 (1 PSC)
	Rpm	825	825	825
	Watts	325	325	325
	Diameter (Number) - in.	(1) 24	(1) 24	(1) 24
	Blades	4	4	4
	Total air volume - cfm	3950	3950	3950
Indoor Coil	Net face area - ft. ²	7.0	7.0	7.0
	Rows	1	1	1
	Fins - in.	20	20	20
	Condensate drain size (NPT) - in.	(1) 1	(1) 1	(1) 1
	Expansion device type	Balanced Port Thermostatic Expansion Valve removable power head		
Indoor Blower	Blower Type	PSC	ECM	ECM
	Nominal Motor HP	0.5	1	1
	Wheel (Number) diameter x width - in.	(1) 10 x 10	(1) 11 x 10	(1) 11 x 10
Filters	Type	MERV 4, Disposable		
	Number and size - in.	(4) 16 x 20 x 2		
Line voltage data (Volts-Phase-Hz)		208/230-1-60 208/230-3-60 460-3-60 575-3-60	208/230-1-60 208/230-3-60 460-3-60 575-3-60	

NOTE - Net capacity includes evaporator blower motor heat deduction. Gross capacity does not include evaporator blower motor heat deduction.

¹ AHRI Certified to AHRI Standard 210/240: 95°F outdoor air temperature and 80°F db/67°F wb entering evaporator air; minimum external duct static pressure.

SPECIFICATIONS - BELT DRIVE BLOWER		5 TON 6 TON	
Model		LCX060S5B	LCX072S5T
Nominal Tonnage		5	6
Efficiency Type		Standard	Standard
Blower Type		Single Speed Belt Drive	Two Speed Belt Drive
Cooling Performance	Gross Cooling Capacity (Btuh)	60,900	72,000
	¹ Net Cooling Capacity (Btuh)	58,000	68,000
	¹ AHRI Rated Air Flow (cfm)	1900	2200
	¹ SEER2 (Btuh/Watt)	14.0	---
	¹ EER2 (Btuh/Watt)	11.5	---
	¹ IEER (Btuh/Watt)	---	15.5
	¹ EER (Btuh/Watt)	---	11.2
	Total Unit Power (kW)	5.0	5.6
Sound Rating Number	dBA	74	79
Refrigerant Charge	Refrigerant Type	R-454B	R-454B
	Without Reheat Option	3 lbs. 12 oz.	5 lbs. 3 oz.
	With Reheat Option	3 lbs. 12 oz.	5 lbs. 8 oz.
Electric Heat Available		See page 42	
Compressor Type (Number)		Scroll (1)	Two-Stage Scroll (1)
Outdoor Coil	Net face area - sq. ft.	14.5	17.8
	Rows	1	1
	Fins - in.	23	23
Outdoor Coil Fan	Motor HP (number and type)	1/4 (1 PSC)	(1) 1/3 (PSC)
	Rpm	825	1075
	Watts	325	375
	Diameter (Number) - in.	(1) 24	(1) 24
	Blades	4	3
	Total air volume - cfm	3950	4700
Indoor Coil	Net face area - sq. ft.	7.0	8.7
	Rows	1	1
	Fins - in.	20	20
	Condensate drain size (NPT) - in.	(1) 1	(1) 1 in.
	Expansion device type	Balanced Port Thermostatic Expansion Valve removable power head	
³ Indoor Blower & Drive Selection	Nominal Motor HP	2	2
	Maximum Usable Motor HP (US)	2.3	2.3
	Available Drive Kits	A07 1212 - 1548 rpm	A04 968 - 1340 rpm A08 1193-1591 rpm
	Wheel (Number) diameter x width - in.	(1) 10 x 10	(1) 10 x 10
Filters	Type	Disposable	
	Number and size - in.	(4) 16 x 20 x 2	(4) 20 x 20 x 2
Line voltage data (Volts-Phase-Hz)		208/230-3-60 460-3-60 575-3-60	

NOTE - Net capacity includes evaporator blower motor heat deduction. Gross capacity does not include evaporator blower motor heat deduction.

¹ AHRI Certified to AHRI Standard 210/240 (2-5 ton) or 340/360 (6 ton): 95°F outdoor air temperature and 80°F db/67°F wb entering evaporator air; minimum external duct static pressure.

² Using total air volume and system static pressure requirements determine from blower performance tables rpm and motor HP required. Maximum usable HP of motors furnished are shown. In Canada, nominal motor HP is also maximum usable motor HP output. If motors of comparable HP are used, be sure to keep within the service factor limitations outlined on the motor nameplate.

RATINGS

NOTE – For Temperatures and Capacities not shown in tables, see bulletin – Cooling Unit Rating Table Correction Factor Data in Miscellaneous Engineering Data section.

2 TON - LCX024S5

Entering Wet Bulb Temperature	Total Air Volume	Outdoor Air Temperature Entering Outdoor Coil																				
		85°F						95°F					105°F					115°F				
		Total Cool Cap.	Comp. Motor Input	Sensible To Total Ratio (S/T)			Total Cool Cap.	Comp. Motor Input	Sensible To Total Ratio (S/T)			Total Cool Cap.	Comp. Motor Input	Sensible To Total Ratio (S/T)			Total Cool Cap.	Comp. Motor Input	Sensible To Total Ratio (S/T)			
				Dry Bulb					Dry Bulb					Dry Bulb					Dry Bulb			
cfm	kBtuh	kW	75°F	80°F	85°F	kBtuh	kW	75°F	80°F	85°F	kBtuh	kW	75°F	80°F	85°F	kBtuh	kW	75°F	80°F	85°F		
63°F	640	23.3	1.29	0.7	0.84	0.99	22.3	1.48	0.72	0.86	1	21.4	1.7	0.73	0.88	1	20.4	1.96	0.75	0.91	1	
	800	24.6	1.28	0.76	0.94	1	23.6	1.47	0.78	0.96	1	22.6	1.69	0.8	0.99	1	21.7	1.95	0.82	1	1	
	960	25.9	1.27	0.82	1	1	25	1.46	0.85	1	1	24.1	1.69	0.87	1	1	23	1.94	0.9	1	1	
67°F	640	24.9	1.28	0.56	0.68	0.8	23.9	1.47	0.57	0.69	0.82	22.9	1.69	0.58	0.7	0.84	21.7	1.95	0.59	0.72	0.87	
	800	26.2	1.27	0.59	0.73	0.89	25.1	1.46	0.6	0.75	0.92	24.1	1.69	0.61	0.77	0.95	22.8	1.94	0.63	0.79	0.98	
	960	27.2	1.26	0.63	0.8	0.98	26	1.46	0.64	0.82	1	24.9	1.69	0.65	0.84	1	23.5	1.94	0.67	0.88	1	
71°F	640	26.7	1.27	0.43	0.54	0.65	25.6	1.46	0.44	0.55	0.66	24.6	1.69	0.44	0.56	0.68	23.3	1.94	0.44	0.57	0.69	
	800	28	1.26	0.45	0.58	0.71	26.8	1.45	0.45	0.59	0.72	25.6	1.68	0.46	0.6	0.74	24.4	1.94	0.46	0.61	0.77	
	960	29	1.25	0.46	0.61	0.77	27.8	1.45	0.47	0.63	0.79	26.4	1.67	0.47	0.64	0.82	25.2	1.93	0.48	0.66	0.85	

3 TON - LCX036S5

Entering Wet Bulb Temperature	Total Air Volume	Outdoor Air Temperature Entering Outdoor Coil																				
		85°F						95°F					105°F					115°F				
		Total Cool Cap.	Comp. Motor Input	Sensible To Total Ratio (S/T)			Total Cool Cap.	Comp. Motor Input	Sensible To Total Ratio (S/T)			Total Cool Cap.	Comp. Motor Input	Sensible To Total Ratio (S/T)			Total Cool Cap.	Comp. Motor Input	Sensible To Total Ratio (S/T)			
				Dry Bulb					Dry Bulb					Dry Bulb					Dry Bulb			
cfm	kBtuh	kW	75°F	80°F	85°F	kBtuh	kW	75°F	80°F	85°F	kBtuh	kW	75°F	80°F	85°F	kBtuh	kW	75°F	80°F	85°F		
63°F	960	35.6	2	0.66	0.82	0.99	34.2	2.28	0.67	0.84	1	32.6	2.67	0.69	0.87	1	30.9	3.15	0.71	0.91	1	
	1200	37.5	2	0.72	0.93	1	36.2	2.28	0.74	0.95	1	34.6	2.61	0.76	0.99	1	32.9	3.12	0.79	1	1	
	1440	39.5	2.01	0.8	1	1	38.2	2.28	0.82	1	1	36.6	2.59	0.85	1	1	34.9	3.08	0.89	1	1	
67°F	960	37.9	2.01	0.53	0.64	0.77	36.6	2.29	0.53	0.65	0.79	34.8	2.61	0.54	0.66	0.82	32.9	3.12	0.55	0.68	0.86	
	1200	39.8	2.01	0.56	0.69	0.88	38.2	2.28	0.57	0.71	0.91	36.4	2.6	0.58	0.73	0.94	34.5	3.09	0.59	0.76	0.98	
	1440	41.2	2.01	0.59	0.76	0.99	39.5	2.27	0.6	0.79	1	37.6	2.59	0.61	0.82	1	35.6	3.07	0.63	0.86	1	
71°F	960	40.5	2.01	0.41	0.51	0.62	38.9	2.27	0.41	0.52	0.63	37.2	2.59	0.41	0.53	0.64	35.3	3.07	0.42	0.54	0.66	
	1200	42.4	2.01	0.42	0.54	0.67	40.6	2.27	0.42	0.55	0.68	38.8	2.58	0.43	0.56	0.7	36.7	3.04	0.43	0.58	0.73	
	1440	43.7	2.01	0.43	0.58	0.73	41.8	2.27	0.44	0.59	0.76	39.9	2.58	0.44	0.6	0.79	37.9	3.03	0.45	0.62	0.82	

4 TON - LCX048S5

Entering Wet Bulb Temperature	Total Air Volume	Outdoor Air Temperature Entering Outdoor Coil																				
		85°F						95°F					105°F					115°F				
		Total Cool Cap.	Comp. Motor Input	Sensible To Total Ratio (S/T)			Total Cool Cap.	Comp. Motor Input	Sensible To Total Ratio (S/T)			Total Cool Cap.	Comp. Motor Input	Sensible To Total Ratio (S/T)			Total Cool Cap.	Comp. Motor Input	Sensible To Total Ratio (S/T)			
				Dry Bulb					Dry Bulb					Dry Bulb					Dry Bulb			
cfm	kBtuh	kW	75°F	80°F	85°F	kBtuh	kW	75°F	80°F	85°F	kBtuh	kW	75°F	80°F	85°F	kBtuh	kW	75°F	80°F	85°F		
63°F	1280	47.3	2.81	0.69	0.84	1	45.4	3.19	0.71	0.86	1	43.3	3.61	0.72	0.89	1	41.2	4.08	0.74	0.92	1	
	1600	49.9	2.81	0.75	0.94	1	47.8	3.2	0.77	0.97	1	45.7	3.62	0.79	1	1	43.8	4.09	0.82	1	1	
	1920	52.4	2.8	0.82	1	1	50.4	3.2	0.85	1	1	48.4	3.62	0.88	1	1	46.3	4.1	0.91	1	1	
67°F	1280	50.3	2.81	0.55	0.67	0.8	48.1	3.2	0.56	0.68	0.82	45.9	3.62	0.57	0.7	0.85	43.7	4.09	0.58	0.71	0.88	
	1600	52.7	2.8	0.58	0.73	0.9	50.3	3.2	0.59	0.74	0.93	48.1	3.63	0.61	0.76	0.96	45.7	4.1	0.62	0.79	1	
	1920	54.4	2.8	0.62	0.79	0.99	51.9	3.19	0.63	0.82	1	49.5	3.62	0.65	0.85	1	47.1	4.1	0.66	0.88	1	
71°F	1280	53.7	2.8	0.42	0.53	0.65	51.3	3.19	0.43	0.54	0.66	49	3.62	0.43	0.55	0.67	46.7	4.1	0.43	0.56	0.69	
	1600	56	2.79	0.44	0.57	0.7	53.6	3.19	0.44	0.58	0.72	51	3.62	0.45	0.59	0.74	48.5	4.09	0.45	0.6	0.76	
	1920	57.8	2.78	0.45	0.61	0.76	55.1	3.18	0.46	0.62	0.79	52.4	3.61	0.46	0.63	0.82	49.9	4.09	0.47	0.65	0.85	

5 TON - LCX060S5

Entering Wet Bulb Temperature	Total Air Volume	Outdoor Air Temperature Entering Outdoor Coil																				
		85°F						95°F					105°F					115°F				
		Total Cool Cap.	Comp. Motor Input	Sensible To Total Ratio (S/T)			Total Cool Cap.	Comp. Motor Input	Sensible To Total Ratio (S/T)			Total Cool Cap.	Comp. Motor Input	Sensible To Total Ratio (S/T)			Total Cool Cap.	Comp. Motor Input	Sensible To Total Ratio (S/T)			
				Dry Bulb					Dry Bulb					Dry Bulb					Dry Bulb			
cfm	kBtuh	kW	75°F	80°F	85°F	kBtuh	kW	75°F	80°F	85°F	kBtuh	kW	75°F	80°F	85°F	kBtuh	kW	75°F	80°F	85°F		
63°F	1600	56.7	3.6	0.71	0.86	1	54.3	4.07	0.72	0.89	1	51.8	4.6	0.74	0.81	0.95	47.6	5.13	0.69	0.83	0.98	
	2000	59.7	3.63	0.77	0.97	1	57.3	4.1	0.79	1	1	54.9	4.64	0.81	0.9	1	50.2	5.17	0.75	0.92	1	
	2400	62.9	3.65	0.85	1	1	60.4	4.13	0.87	1	1	58	4.68	0.91	0.98	1	52.6	5.21	0.81	1	1	
67°F	1600	60.1	3.63	0.56	0.68	0.82	57.5	4.1	0.57	0.7	0.85	54.8	4.64	0.58	0.65	0.77	50.7	5.18	0.55	0.66	0.79	
	2000	62.8	3.65	0.6	0.74	0.93	60	4.13	0.61	0.76	0.96	57.3	4.67	0.62	0.7	0.85	53.2	5.22	0.58	0.72	0.88	
	2400	64.9	3.67	0.63	0.82	1	61.8	4.14	0.65	0.85	1	59	4.69	0.66	0.76	0.94	55.2	5.25	0.61	0.78	0.97	
71°F	1600	64.1	3.66	0.43	0.54	0.66	61.3	4.14	0.43	0.55	0.67	58.5	4.68	0.43	0.52	0.62	54.1	5.23	0.42	0.53	0.64	
	2000	66.8	3.68	0.44	0.58	0.72	63.8	4.16	0.45	0.59	0.74	60.8	4.71	0.45	0.55	0.67	56.4	5.26	0.43	0.56	0.69	
	2400	68.7	3.69	0.46	0.62	0.79	65.5	4.17	0.46	0.64	0.82	62.4	4.72	0.47	0.58	0.73	58.4	5.29	0.45	0.6	0.76	

RATINGS

NOTE – For Temperatures and Capacities not shown in tables, see bulletin – Cooling Unit Rating Table Correction Factor Data in Miscellaneous Engineering Data section.

6 TON - LCX072S5T (PART LOAD)

Entering Wet Bulb Temperature	Total Air Volume	Outdoor Air Temperature Entering Outdoor Coil																							
		65°F						75°F						85°F						95°F					
		Total Cool Cap.	Comp. Motor Input	Sensible To Total Ratio (S/T)			Total Cool Cap.	Comp. Motor Input	Sensible To Total Ratio (S/T)			Total Cool Cap.	Comp. Motor Input	Sensible To Total Ratio (S/T)			Total Cool Cap.	Comp. Motor Input	Sensible To Total Ratio (S/T)						
				Dry Bulb					Dry Bulb					Dry Bulb					Dry Bulb						
cfm	kBtuh	kW	75°F	80°F	85°F	kBtuh	kW	75°F	80°F	85°F	kBtuh	kW	75°F	80°F	85°F	kBtuh	kW	75°F	80°F	85°F					
63°F	1200	49.8	2.79	0.72	0.85	0.97	47.3	3.23	0.74	0.87	0.99	44.5	3.72	0.75	1	1	48.4	4.23	0.93	1	1				
	1600	53.9	2.77	0.79	0.94	1	51.1	3.22	0.81	0.97	1	48.2	3.71	0.83	1	1	51.9	4.22	1	1	1				
	2000	57.4	2.75	0.86	1	1	54.9	3.2	0.88	1	1	52	3.69	0.91	1	1	54.3	4.21	1	1	1				
67°F	1200	53.4	2.77	0.58	0.69	0.81	50.7	3.22	0.59	0.71	0.83	47.7	3.71	0.6	0.87	1	49.4	4.23	0.71	0.91	1				
	1600	57.3	2.75	0.62	0.76	0.9	54.3	3.2	0.63	0.78	0.93	51	3.69	0.64	0.96	1	51.9	4.22	0.77	1	1				
	2000	60	2.74	0.66	0.83	0.99	56.8	3.19	0.67	0.86	1	53.4	3.68	0.69	1	1	54.4	4.21	0.84	1	1				
71°F	1200	57.4	2.75	0.45	0.56	0.66	54.6	3.2	0.45	0.56	0.68	51.5	3.69	0.46	0.67	0.84	52.9	4.21	0.5	0.69	0.88				
	1600	61.5	2.73	0.46	0.6	0.73	58.3	3.18	0.47	0.61	0.75	54.9	3.68	0.47	0.73	0.94	54.7	4.2	0.53	0.76	0.98				
	2000	64.3	2.72	0.48	0.64	0.8	60.8	3.17	0.49	0.66	0.83	57.2	3.67	0.5	0.8	1	56.1	4.2	0.56	0.83	1				

6 TON - LCX072S5T (FULL LOAD)

Entering Wet Bulb Temperature	Total Air Volume	Outdoor Air Temperature Entering Outdoor Coil																							
		85°F						95°F						105°F						115°F					
		Total Cool Cap.	Comp. Motor Input	Sensible To Total Ratio (S/T)			Total Cool Cap.	Comp. Motor Input	Sensible To Total Ratio (S/T)			Total Cool Cap.	Comp. Motor Input	Sensible To Total Ratio (S/T)			Total Cool Cap.	Comp. Motor Input	Sensible To Total Ratio (S/T)						
				Dry Bulb					Dry Bulb					Dry Bulb					Dry Bulb						
cfm	kBtuh	kW	75°F	80°F	85°F	kBtuh	kW	75°F	80°F	85°F	kBtuh	kW	75°F	80°F	85°F	kBtuh	kW	75°F	80°F	85°F					
63°F	1920	71.5	4.07	0.75	0.89	1	68.2	4.61	0.77	0.91	1	64.9	5.23	0.78	0.93	1	61.3	5.91	0.81	0.96	1				
	2400	75.3	4.11	0.81	0.97	1	72	4.66	0.83	0.99	1	68.8	5.27	0.85	1	1	65.2	5.95	0.88	1	1				
	2880	79.3	4.16	0.87	1	1	76	4.7	0.9	1	1	72.5	5.32	0.92	1	1	68.7	6	0.95	1	1				
67°F	1920	75.8	4.12	0.6	0.73	0.85	72.3	4.66	0.61	0.74	0.88	68.7	5.27	0.62	0.76	0.9	64.6	5.94	0.63	0.78	0.93				
	2400	79.4	4.16	0.63	0.79	0.94	75.6	4.7	0.64	0.81	0.96	71.7	5.31	0.66	0.83	0.99	67.4	5.98	0.67	0.86	1				
	2880	82.1	4.19	0.67	0.85	1	77.9	4.72	0.69	0.88	1	73.7	5.34	0.7	0.9	1	69.5	6.01	0.72	0.93	1				
71°F	1920	81	4.17	0.46	0.58	0.7	77.1	4.72	0.46	0.59	0.72	73.2	5.33	0.46	0.6	0.73	68.9	6	0.47	0.61	0.76				
	2400	84.5	4.21	0.47	0.62	0.76	80.4	4.75	0.48	0.63	0.78	76.1	5.36	0.48	0.64	0.81	71.6	6.03	0.49	0.66	0.83				
	2880	87	4.24	0.49	0.66	0.83	82.8	4.78	0.49	0.67	0.85	78.1	5.39	0.5	0.69	0.88	73.5	6.06	0.51	0.71	0.91				

HUMIDITROL® DEHUMIDIFICATION SYSTEM RATINGS

2 TON - LCX024S5 WITH HUMIDITROL® DEHUMIDIFICATION OPERATING

Entering Wet Bulb Temperature	Total Air Volume	Outdoor Air Temperature Entering Outdoor Coil																			
		65°F					75°F					85°F					95°F				
		Total Cool Cap.	Comp. Motor Input	Sensible To Total Ratio (S/T)			Total Cool Cap.	Comp. Motor Input	Sensible To Total Ratio (S/T)			Total Cool Cap.	Comp. Motor Input	Sensible To Total Ratio (S/T)			Total Cool Cap.	Comp. Motor Input	Sensible To Total Ratio (S/T)		
				Dry Bulb					Dry Bulb					Dry Bulb					Dry Bulb		
cfm	kBtuh	kW	75°F	80°F	85°F	kBtuh	kW	75°F	80°F	85°F	kBtuh	kW	75°F	80°F	85°F	kBtuh	kW	75°F	80°F	85°F	
63°F	640	18.4	920	.61	.78	.94	15.2	1050	.55	.76	.95	11.8	1200	.46	.74	.97	8.4	1360	.31	.68	.89
	800	19.7	910	.67	.86	1.00	16.0	1040	.62	.85	1.00	12.2	1180	.53	.85	1.00	8.3	1350	.37	.84	.96
	960	21.0	900	.72	.86	.99	16.5	1030	.68	.95	1.00	12.4	1170	.61	.95	1.00	8.2	1340	.48	.99	1.00
67°F	640	20.5	920	.45	.61	.77	17.2	1050	.36	.56	.74	13.9	1200	.27	.49	.71	10.4	1360	.01	.36	.67
	800	21.8	910	.48	.66	.83	18.1	1040	.40	.63	.82	14.3	1180	.27	.56	.81	10.3	1350	.02	.45	.81
	960	22.7	900	.52	.72	.89	18.6	1030	.42	.70	.90	14.5	1170	.29	.63	.93	10.2	1340	.03	.54	.94
71°F	640	22.9	920	.28	.46	.60	19.2	1050	.21	.39	.56	15.8	1200	.06	.29	.50	12.3	1360	-.18	.13	.41
	800	24.0	910	.32	.50	.65	20.3	1040	.22	.43	.62	16.4	1180	.06	.33	.59	12.4	1350	-.22	.16	.50
	960	25.1	900	.34	.53	.71	21.0	1030	.23	.47	.69	16.7	1170	.06	.37	.66	12.3	1340	-.25	.19	.57

3 TON - LCX036S5 WITH HUMIDITROL® DEHUMIDIFICATION OPERATING

Entering Wet Bulb Temperature	Total Air Volume	Outdoor Air Temperature Entering Outdoor Coil																			
		65°F					75°F					85°F					95°F				
		Total Cool Cap.	Comp. Motor Input	Sensible To Total Ratio (S/T)			Total Cool Cap.	Comp. Motor Input	Sensible To Total Ratio (S/T)			Total Cool Cap.	Comp. Motor Input	Sensible To Total Ratio (S/T)			Total Cool Cap.	Comp. Motor Input	Sensible To Total Ratio (S/T)		
				Dry Bulb					Dry Bulb					Dry Bulb					Dry Bulb		
cfm	kBtuh	kW	75°F	80°F	85°F	kBtuh	kW	75°F	80°F	85°F	kBtuh	kW	75°F	80°F	85°F	kBtuh	kW	75°F	80°F	85°F	
63°F	960	23.7	1530	.58	.76	.94	20.4	1720	.54	.75	.95	16.7	1940	.48	.74	.98	12.7	2190	.35	.71	1.00
	1200	24.8	1540	.64	.85	.99	21.0	1730	.61	.85	.91	16.9	1930	.56	.87	1.00	12.5	2180	.47	.88	1.00
	1440	25.6	1550	.70	.94	1.00	21.5	1730	.68	.96	.96	17.1	1930	.64	1.00	1.00	12.6	2170	.58	.97	1.00
67°F	960	26.4	1550	.41	.57	.73	23.0	1740	.36	.54	.71	19.4	1950	.27	.49	.70	15.6	2190	.13	.41	.68
	1200	27.7	1560	.44	.63	.81	23.9	1750	.39	.60	.82	19.8	1950	.30	.56	.74	15.4	2190	.16	.50	.83
	1440	28.5	1570	.47	.69	.91	24.4	1750	.42	.67	.91	19.9	1950	.33	.64	.95	15.1	2180	.18	.59	.98
71°F	960	29.0	1570	.27	.41	.56	25.7	1760	.20	.37	.53	22.0	1970	.11	.30	.49	18.2	2200	-.03	.20	.43
	1200	30.6	1590	.28	.44	.61	26.7	1770	.20	.40	.59	22.6	1970	.10	.34	.56	18.3	2200	-.05	.24	.51
	1440	31.5	1600	.29	.49	.67	27.3	1780	.21	.44	.66	22.9	1970	.10	.37	.63	18.2	2200	-.08	.27	.60

4 TON - LCX048S5 WITH HUMIDITROL® DEHUMIDIFICATION OPERATING

Entering Wet Bulb Temperature	Total Air Volume	Outdoor Air Temperature Entering Outdoor Coil																			
		65°F					75°F					85°F					95°F				
		Total Cool Cap.	Comp. Motor Input	Sensible To Total Ratio (S/T)			Total Cool Cap.	Comp. Motor Input	Sensible To Total Ratio (S/T)			Total Cool Cap.	Comp. Motor Input	Sensible To Total Ratio (S/T)			Total Cool Cap.	Comp. Motor Input	Sensible To Total Ratio (S/T)		
				Dry Bulb					Dry Bulb					Dry Bulb					Dry Bulb		
cfm	kBtuh	kW	75°F	80°F	85°F	kBtuh	kW	75°F	80°F	85°F	kBtuh	kW	75°F	80°F	85°F	kBtuh	kW	75°F	80°F	85°F	
63°F	1280	35.7	2160	.58	.77	.93	29.5	2440	.54	.76	.98	23.3	2730	.46	.74	.98	17.3	3060	.32	.71	1.00
	1600	37.4	2160	.65	.85	1.00	30.7	2430	.62	.84	1.00	23.9	2730	.52	.85	1.00	17.3	3040	.42	.84	1.00
	1920	38.7	2160	.70	.91	1.00	31.5	2430	.65	.92	1.00	24.0	2720	.66	.96	.94	17.0	3030	.44	1.00	1.00
67°F	1280	39.4	2180	.41	.58	.73	33.0	2460	.34	.54	.73	26.8	2760	.22	.48	.71	20.7	3090	.02	.37	.68
	1600	41.1	2180	.45	.64	.82	34.2	2460	.37	.61	.82	27.3	2750	.29	.57	.81	20.7	3080	.02	.44	.82
	1920	42.1	2170	.42	.71	.89	34.6	2450	.40	.69	.90	27.6	2750	.25	.61	.93	20.3	3060	.01	.55	.96
71°F	1280	42.8	2200	.26	.43	.57	36.4	2480	.17	.36	.54	30.1	2790	.02	.27	.48	23.8	3120	-.19	.12	.41
	1600	44.6	2200	.28	.45	.63	37.5	2480	.18	.40	.60	30.6	2780	.07	.31	.57	23.7	3110	-.24	.14	.52
	1920	45.7	2190	.26	.49	.69	38.1	2480	.18	.43	.65	30.5	2770	.12	.37	.62	23.6	3100	-.32	.11	.58

5 TON - LCX060S5 WITH HUMIDITROL® DEHUMIDIFICATION OPERATING

Entering Wet Bulb Temperature	Total Air Volume	Outdoor Air Temperature Entering Outdoor Coil																			
		65°F					75°F					85°F					95°F				
		Total Cool Cap.	Comp. Motor Input	Sensible To Total Ratio (S/T)			Total Cool Cap.	Comp. Motor Input	Sensible To Total Ratio (S/T)			Total Cool Cap.	Comp. Motor Input	Sensible To Total Ratio (S/T)			Total Cool Cap.	Comp. Motor Input	Sensible To Total Ratio (S/T)		
				Dry Bulb					Dry Bulb					Dry Bulb					Dry Bulb		
cfm	kBtuh	kW	75°F	80°F	85°F	kBtuh	kW	75°F	80°F	85°F	kBtuh	kW	75°F	80°F	85°F	kBtuh	kW	75°F	80°F	85°F	
63°F	1600	42.3	2750	.50	.73	.93	35.3	3020	.45	.69	.95	27.9	3340	.33	.64	.97	19.7	3730	.12	.55	.99
	2000	44.2	2770	.60	.83	1.00	35.9	3030	.52	.85	1.00	30.1	3360	.43	.85	1.00	18.9	3720	.22	.76	.99
	2400	45.3	2780	.67	.95	.99	37.0	3040	.59	.93	.98	28.4	3340	.51	.93	.98	18.5	3720	.29	.91	1.00
67°F	1600	47.7	2800	.34	.52	.70	40.4	3060	.25	.46	.66	33.2	3380	.11	.36	.62	25.1	3770	-.12	.22	.55
	2000	49.5	2810	.40	.60	.79	41.8	3080	.28	.52	.78	33.5	3380	.16	.44	.77	24.3	3760	-.15	.31	.74
	2400	50.8	2830	.41	.66	.90	42.3	3080	.30	.59	.89	32.9	3370	.15	.56	.88	23.0	3740	-.19	.43	.88
71°F	1600	54.3	2850	.18	.28	.51	45.7	3110	.10	.28	.45	38.2	3430	-.05	.17	.39	29.9	3810	-.30	.01	.27
	2000	55.3	2860	.16	.38	.56	46.6	3110	.09	.32	.51	38.3	3420	-.07	.21	.46	29.1	3800	-.38	.03	.37
	2400	56.1	2870	.21	.42	.64	46.8	3110	.09	.35	.59	37.7	3420	-.10	.23	.55	28.1	3780	-.48	.03	.48

HUMIDITROL® DEHUMIDIFICATION SYSTEM RATINGS

6 TON - LCX072S5 WITH HUMIDITROL® DEHUMIDIFICATION OPERATING

Entering Wet Bulb Temperature	Total Air Volume	Outdoor Air Temperature Entering Outdoor Coil																							
		65°F						75°F						85°F						95°F					
		Total Cool Cap.	Comp. Motor Input	Sensible To Total Ratio (S/T)			Total Cool Cap.	Comp. Motor Input	Sensible To Total Ratio (S/T)			Total Cool Cap.	Comp. Motor Input	Sensible To Total Ratio (S/T)			Total Cool Cap.	Comp. Motor Input	Sensible To Total Ratio (S/T)						
				Dry Bulb					Dry Bulb					Dry Bulb					Dry Bulb						
cfm	kBtuh	kW	75°F	80°F	85°F	kBtuh	kW	75°F	80°F	85°F	kBtuh	kW	75°F	80°F	85°F	kBtuh	kW	75°F	80°F	85°F					
63°F	1920	43.6	3210	.54	.74	.93	36.3	3520	.47	.73	.95	29.1	3890	.37	.69	.96	21.3	4320	.21	.64	1.00				
	2400	45.8	3250	.61	.82	1.00	37.9	3550	.54	.80	1.00	29.1	3890	.43	.87	.88	20.7	4310	.25	.87	.99				
	2880	46.5	3270	.63	.95	.99	38.2	3550	.63	.95	.98	29.7	3900	.60	.95	.98	20.6	4310	.31	.97	1.00				
67°F	1920	48.8	3280	.34	.52	.70	41.4	3590	.27	.48	.69	34.0	3960	.15	.40	.67	25.9	4400	-.19	.29	.64				
	2400	50.7	3310	.37	.57	.81	42.7	3610	.28	.52	.79	34.0	3960	.08	.47	.76	25.5	4390	-.10	.36	.79				
	2880	51.4	3320	.39	.65	.91	43.1	3620	.24	.60	.88	33.2	3950	.01	.61	.90	24.9	4380	-.15	.38	.91				
71°F	1920	53.6	3330	.19	.35	.51	46.3	3650	.09	.28	.47	38.4	4030	-.04	.19	.40	30.2	4470	-.29	.05	.33				
	2400	55.0	3360	.22	.38	.57	46.8	3660	.09	.31	.54	38.1	4020	-.07	.22	.47	29.1	4450	-.37	.06	.41				
	2880	55.7	3370	.25	.41	.64	46.7	3660	.10	.34	.59	37.4	4020	-.10	.23	.55	26.1	4400	-.46	.25	.50				

BLOWER DATA

DIRECT DRIVE - 2 TON [PSC]

LCX024S5D

BLOWER TABLE INCLUDES RESISTANCE FOR BASE UNIT ONLY WITH DRY INDOOR COIL AND AIR FILTERS IN PLACE.

FOR ALL UNITS ADD:

1 - Any factory installed options air resistance (economizer, wet coil, etc.) See page 32.

2 - Any field installed accessories air resistance (electric heat, duct resistance, diffuser, etc.) See page 32.

External Static Pressure (in. w.g.)	Air Volume (cfm) at Various Blower Speeds					
	208 VOLTS			230 VOLTS		
	High	Medium	Low	High	Medium	Low
2 Ton Standard Efficiency (Downflow)						LCX024S
0.0	1244	956	859	1414	1098	876
0.1	1226	934	820	1401	1092	870
0.2	1201	906	782	1379	1070	848
0.3	1180	877	727	1348	1039	819
0.4	1152	841	690	1318	1008	775
0.5	1118	812	634	1288	968	746
0.6	1090	768	579	1243	937	702
0.7	1048	725	505	1197	890	659
0.8	1006	667	431	1152	827	600
0.9	950	609	357	1076	749	528
1.0	839	493	248	986	623	468
2 Ton Standard Efficiency (Horizontal)						LCX024S
0.0	1166	910	801	1376	1071	842
0.1	1156	893	770	1342	1054	826
0.2	1136	866	734	1307	1021	808
0.3	1115	826	697	1269	982	771
0.4	1083	800	643	1232	956	734
0.5	1051	747	589	1194	903	698
0.6	1009	707	534	1137	850	662
0.7	946	668	467	1100	797	588
0.8	861	588	396	1024	744	534
0.9	736	508	319	948	652	466
1.0	560	385	237	845	549	392

BLOWER DATA

DIRECT DRIVE - 3 TON | 4 TON [PSC]

LCX036S5D | LCX048S5D

BLOWER TABLE INCLUDES RESISTANCE FOR BASE UNIT ONLY WITH DRY INDOOR COIL AND AIR FILTERS IN PLACE.

FOR ALL UNITS ADD:

1 - Any factory installed options air resistance (economizer, wet coil, etc.) See page 32.

2 - Any field installed accessories air resistance (electric heat, duct resistance, diffuser, etc.) See page 32.

External Static Pressure (in. w.g.)	Air Volume (cfm) at Various Blower Speeds								
	208 VOLTS			230 VOLTS			460/575 VOLTS		
	High	Medium	Low	High	Medium	Low	High	Medium	Low
3 and 4 Ton Standard Efficiency (Downflow)					LCX036S and LCX048S				
0.0	1938	1552	1119	2167	1772	1317	2136	1716	1212
0.1	1992	1586	1128	2167	1780	1315	2104	1728	1208
0.2	1915	1592	1137	2100	1792	1307	2052	1684	1197
0.3	1865	1536	1083	2043	1735	1266	1994	1647	1172
0.4	1813	1495	1033	1986	1678	1204	1918	1597	1134
0.5	1762	1444	976	1909	1621	1164	1861	1534	1096
0.6	1694	1391	899	1814	1535	1082	1765	1485	1059
0.7	1609	1331	817	1718	1478	1000	1689	1410	996
0.8	1471	1220	730	1603	1364	918	1613	1335	920
0.9	1368	1066	522	1488	1250	755	1498	1235	848
1.0	1108	869	402	1259	1021	640	1345	1036	763
3 and 4 Ton Standard Efficiency (Horizontal)					LCX036S and LCX048S				
0.0	1862	1520	1070	2082	1736	1259	2085	1745	1247
0.1	1867	1530	1069	2031	1717	1246	2070	1744	1257
0.2	1804	1485	1067	1978	1672	1227	2016	1690	1225
0.3	1741	1440	1018	1907	1627	1190	1944	1643	1192
0.4	1677	1396	968	1837	1567	1128	1890	1596	1160
0.5	1614	1329	894	1749	1492	1066	1800	1533	1111
0.6	1550	1284	844	1660	1417	1016	1727	1455	1062
0.7	1455	1195	769	1554	1327	941	1655	1377	996
0.8	1329	1106	670	1448	1237	842	1511	1283	865
0.9	1202	927	496	1307	1087	718	1403	1190	784
1.0	1012	828	385	1025	973	613	1222	1002	670

BLOWER DATA

LCX048S5E | LCX060S5E

BLOWER TABLE INCLUDES RESISTANCE FOR BASE UNIT ONLY WITH DRY INDOOR COIL AND AIR FILTERS IN PLACE.

FOR ALL UNITS ADD:

1 - Any factory installed options air resistance (economizer, wet coil, etc.) See page 32.

2 - Any field installed accessories air resistance (electric heat, duct resistance, diffuser, etc.) See page 32.

See See page 32 for minimum air volume with electric heat.

DIRECT DRIVE - 3 TON | 4 TON | 5 TON | 1 HP ECM

External Static Press. in. w.g.	Percentage of Total Motor Torque																																			
	20%				30%				40%				50%				60%				70%				80%				90%				100%			
	Cfm	Watts	RPM	Cfm	Watts	RPM	Cfm	Watts	RPM	Cfm	Watts	RPM	Cfm	Watts	RPM	Cfm	Watts	RPM	Cfm	Watts	RPM	Cfm	Watts	RPM	Cfm	Watts	RPM	Cfm	Watts	RPM						
0	1067	112	488	1325	196	573	1583	279	657	1759	381	726	1934	482	794	2046	579	845	2157	676	896	2285	816	956	2358	925	989									
0.1	984	97	537	1249	184	616	1513	270	695	1697	376	760	1881	481	825	2002	584	873	2123	686	921	2273	838	978	2352	947	1008									
0.2	912	91	587	1183	180	661	1453	268	735	1644	377	796	1835	486	856	1964	593	902	2093	700	947	2264	863	1001	2349	973	1030									
0.3	851	92	636	1126	183	706	1400	273	775	1597	385	832	1794	497	889	1931	607	932	2067	717	974	2256	891	1026	2348	1001	1053									
0.4	797	100	687	1075	192	751	1353	283	815	1555	397	869	1757	511	922	1901	625	962	2044	738	1002	2248	919	1051	2347	1031	1077									
0.5	752	114	737	1032	206	796	1312	298	855	1518	413	905	1724	528	955	1873	644	993	2021	760	1030	2239	948	1078	2345	1061	1102									
0.6	712	132	787	994	224	842	1275	316	896	1484	432	942	1692	548	988	1845	666	1024	1998	783	1059	2228	977	1104	---	---	---									
0.7	678	155	836	960	246	886	1242	336	936	1452	452	979	1662	568	1021	1818	687	1055	1974	806	1088	2214	1004	1131	---	---	---									
0.8	648	180	885	929	269	931	1210	358	976	1421	474	1016	1632	589	1055	1790	709	1086	1948	828	1117	2195	1028	1158	---	---	---									
0.9	621	207	933	900	294	974	1179	381	1015	1390	495	1051	1600	609	1087	1760	728	1117	1919	847	1146	2170	1049	1185	---	---	---									
1.0	596	235	981	872	319	1017	1148	403	1053	1357	516	1086	1566	628	1119	1725	746	1147	1884	864	1174	2139	1066	1212	---	---	---									
1.1	---	---	---	---	---	---	1115	424	1090	1322	534	1120	1528	643	1150	1686	760	1176	1844	876	1201	2100	1078	1238	---	---	---									
1.2	---	---	---	---	---	---	1080	443	1126	1283	549	1153	1485	655	1180	1641	770	1204	1797	884	1228	2052	1083	1264	---	---	---									
1.3	---	---	---	---	---	---	1040	458	1161	1238	561	1185	1436	663	1209	1589	775	1231	1742	886	1253	1993	1081	1288	---	---	---									
1.4	---	---	---	---	---	---	996	469	1194	1189	567	1215	1381	665	1236	1530	773	1257	1678	881	1277	1923	1071	1311	---	---	---									

HORIZONTAL

External Static Press. in. w.g.	Percentage of Total Motor Torque																																			
	20%				30%				40%				50%				60%				70%				80%				90%				100%			
	Cfm	Watts	RPM	Cfm	Watts	RPM	Cfm	Watts	RPM	Cfm	Watts	RPM	Cfm	Watts	RPM	Cfm	Watts	RPM	Cfm	Watts	RPM	Cfm	Watts	RPM	Cfm	Watts	RPM	Cfm	Watts	RPM						
0	1087	111	493	1304	184	579	1520	257	665	1689	368	738	1857	478	810	1972	588	864	2087	698	918	2196	844	975	2283	925	1000									
0.1	1021	104	537	1246	180	618	1470	255	699	1646	368	768	1821	480	837	1941	592	888	2061	704	938	2179	852	992	2255	926	1017									
0.2	961	102	582	1193	181	658	1425	259	734	1607	373	799	1789	487	864	1914	601	912	2039	714	960	2163	864	1012	2231	932	1034									
0.3	906	106	628	1145	186	699	1384	266	769	1572	382	831	1759	498	892	1889	613	938	2018	728	984	2149	879	1033	2209	941	1053									
0.4	855	113	674	1101	196	740	1347	278	806	1540	396	864	1732	513	921	1866	629	965	1999	744	1008	2134	896	1054	---	---	---									
0.5	808	125	720	1060	209	781	1312	293	842	1509	412	896	1706	530	950	1843	646	992	1980	762	1033	2119	915	1077	---	---	---									
0.6	764	139	766	1022	225	823	1279	310	879	1481	430	930	1682	549	980	1821	666	1019	1960	782	1058	2102	935	1101	---	---	---									
0.7	722	155	812	984.5	242	864	1247	328	916	1452	449	964	1657	569	1011	1799	686	1048	1940	803	1084	2084	955	1125	---	---	---									
0.8	682	172	858	949	260	906	1216	348	953	1424	469	997	1632	589	1041	1776	706	1076	1919	823	1111	2063	974	1150	---	---	---									
0.9	643	191	903	914	279	946	1185	367	989	1396	489	1030	1606	610	1071	1751	727	1104	1895	843	1137	2039	992	1175	---	---	---									
1.0	---	---	---	---	---	---	1153	386	1024	1366	508	1062	1579	629	1100	1724	745	1132	1869	861	1163	2011	1008	1201	---	---	---									
1.1	---	---	---	---	---	---	1120	404	1059	1334	525	1095	1548	646	1130	1694	761	1160	1839	876	1189	1979	1021	1226	---	---	---									
1.2	---	---	---	---	---	---	1085	420	1093	1300	541	1126	1515	661	1158	1660	775	1186	1805	889	1214	1941	1031	1250	---	---	---									
1.3	---	---	---	---	---	---	1047	433	1126	1263	553	1156	1478	672	1186	1622	785	1213	1766	898	1239	1897	1037	1275	---	---	---									
1.4	---	---	---	---	---	---	1005	442	1158	1221	561	1185	1436	680	1212	1579	792	1238	1721	903	1263	1847	1037	1298	---	---	---									

BLOWER DATA

BELT DRIVE (SINGLE SPEED) - 5 TON

LCX060S5B

BLOWER TABLE INCLUDES RESISTANCE FOR BASE UNIT ONLY WITH DRY INDOOR COIL AND AIR FILTERS IN PLACE.

FOR ALL UNITS ADD:

1 - Any factory installed options air resistance (economizer, wet coil, etc.) See page 32.

2 - Any field installed accessories air resistance (electric heat, duct resistance, diffuser, etc.) See page 32.

See page 32 for blower motors and drives.

DOWNFLOW

Air Volume cfm	External Static - in. w.g.															
	0.10		0.20		0.30		0.40		0.50		0.60		0.70		0.80	
	RPM	BHP	RPM	BHP	RPM	BHP	RPM	BHP	RPM	BHP	RPM	BHP	RPM	BHP	RPM	BHP
1600	665	0.30	716	0.34	768	0.38	819	0.41	879	0.44	937	0.46	985	0.49	1022	0.52
1700	723	0.31	768	0.35	814	0.39	860	0.43	910	0.47	959	0.50	1001	0.54	1037	0.58
1800	779	0.32	818	0.37	857	0.41	897	0.46	939	0.50	980	0.55	1018	0.59	1054	0.64
1900	826	0.36	859	0.41	894	0.45	928	0.50	964	0.56	1000	0.61	1036	0.66	1072	0.70
2000	857	0.42	889	0.47	920	0.52	952	0.57	986	0.62	1020	0.68	1055	0.73	1091	0.77
2100	878	0.49	909	0.54	940	0.59	973	0.64	1006	0.70	1041	0.75	1076	0.80	1112	0.85
2200	897	0.55	929	0.61	961	0.66	994	0.72	1028	0.78	1063	0.83	1099	0.89	1134	0.93
2300	918	0.62	950	0.68	983	0.74	1017	0.80	1052	0.86	1087	0.92	1122	0.97	1157	1.02
2400	941	0.70	974	0.77	1008	0.83	1042	0.90	1077	0.96	1111	1.01	1146	1.06	1181	1.11

Air Volume cfm	External Static - in. w.g.															
	0.90		1.00		1.10		1.20		1.30		1.40		1.50		1.60	
	RPM	BHP	RPM	BHP	RPM	BHP	RPM	BHP	RPM	BHP	RPM	BHP	RPM	BHP	RPM	BHP
1600	1059	0.57	1098	0.61	1138	0.65	1177	0.68	1218	0.71	1257	0.75	1290	0.79	1319	0.83
1700	1074	0.62	1113	0.66	1152	0.70	1190	0.74	1231	0.77	1268	0.80	1299	0.84	1328	0.89
1800	1091	0.68	1129	0.72	1167	0.76	1205	0.80	1244	0.83	1280	0.87	1310	0.91	1338	0.95
1900	1109	0.75	1146	0.79	1183	0.82	1221	0.86	1260	0.90	1294	0.94	1323	0.98	1349	1.02
2000	1128	0.82	1164	0.86	1201	0.89	1239	0.93	1276	0.97	1310	1.01	1336	1.06	1362	1.10
2100	1148	0.89	1185	0.93	1221	0.97	1258	1.01	1294	1.05	1325	1.09	1351	1.14	1376	1.19
2200	1170	0.97	1206	1.01	1242	1.05	1277	1.09	1311	1.14	1341	1.18	1365	1.23	1390	1.28
2300	1193	1.06	1228	1.09	1262	1.14	1295	1.19	1327	1.24	1355	1.29	1380	1.33	1406	1.37
2400	1216	1.15	1250	1.19	1282	1.24	1313	1.30	1343	1.36	1371	1.40	1396	1.44	1423	1.48

HORIZONTAL

Air Volume cfm	External Static - in. w.g.															
	0.10		0.20		0.30		0.40		0.50		0.60		0.70		0.80	
	RPM	BHP	RPM	BHP	RPM	BHP	RPM	BHP	RPM	BHP	RPM	BHP	RPM	BHP	RPM	BHP
1600	712	0.29	758	0.32	807	0.36	855	0.39	906	0.43	955	0.46	997	0.50	1035	0.54
1700	766	0.32	808	0.36	850	0.40	892	0.44	936	0.47	978	0.51	1016	0.56	1052	0.60
1800	814	0.36	851	0.40	888	0.44	925	0.49	963	0.53	1000	0.57	1035	0.62	1071	0.66
1900	853	0.41	886	0.46	919	0.50	952	0.55	986	0.60	1021	0.64	1056	0.69	1091	0.73
2000	883	0.48	913	0.53	944	0.57	976	0.62	1009	0.67	1043	0.71	1078	0.76	1112	0.80
2100	906	0.56	936	0.60	967	0.65	999	0.70	1033	0.75	1067	0.79	1101	0.84	1135	0.88
2200	930	0.64	960	0.68	991	0.73	1024	0.78	1058	0.83	1092	0.88	1126	0.92	1160	0.96
2300	954	0.72	985	0.77	1017	0.82	1051	0.87	1085	0.92	1119	0.96	1152	1.00	1186	1.04
2400	981	0.81	1013	0.86	1046	0.91	1079	0.96	1113	1.00	1146	1.05	1180	1.09	1213	1.13

Air Volume cfm	External Static - in. w.g.															
	0.90		1.00		1.10		1.20		1.30		1.40		1.50		1.60	
	RPM	BHP	RPM	BHP	RPM	BHP	RPM	BHP	RPM	BHP	RPM	BHP	RPM	BHP	RPM	BHP
1600	1071	0.58	1109	0.62	1147	0.66	1186	0.69	1225	0.72	1263	0.76	1299	0.80	1334	0.83
1700	1088	0.64	1126	0.68	1164	0.72	1202	0.75	1240	0.78	1276	0.82	1311	0.86	1345	0.90
1800	1107	0.70	1143	0.74	1181	0.78	1219	0.81	1256	0.85	1291	0.89	1324	0.93	1357	0.97
1900	1126	0.77	1163	0.81	1200	0.85	1237	0.88	1273	0.92	1306	0.96	1339	1.00	1371	1.04
2000	1148	0.84	1183	0.88	1220	0.92	1257	0.96	1291	1.00	1323	1.04	1354	1.08	1385	1.12
2100	1170	0.92	1206	0.96	1242	1.00	1277	1.04	1310	1.08	1340	1.13	1371	1.17	1401	1.21
2200	1195	1.00	1230	1.04	1265	1.08	1299	1.13	1330	1.18	1359	1.23	1388	1.27	1418	1.31
2300	1220	1.08	1254	1.13	1288	1.17	1320	1.23	1350	1.28	1378	1.34	1406	1.38	1435	1.42
2400	1245	1.18	1278	1.22	1311	1.28	1341	1.33	1370	1.40	1397	1.45	1425	1.50	1454	1.54

BLOWER DATA

BELT DRIVE (TWO-SPEED) - 6 TON (DOWNFLOW)

LCX072S5T

BLOWER TABLE INCLUDES RESISTANCE FOR BASE UNIT ONLY WITH DRY INDOOR COIL AND AIR FILTERS IN PLACE.

FOR ALL UNITS ADD:

1 - Any factory installed options air resistance (economizer, wet coil, etc.) See page 32.

2 - Any field installed accessories air resistance (electric heat, duct resistance, diffuser, etc.) See page 32.

See page 32 for blower motors and drives.

Air Volume cfm	External Static - in. w.g.															
	0.10		0.20		0.30		0.40		0.50		0.60		0.70		0.80	
	RPM	BHP	RPM	BHP	RPM	BHP	RPM	BHP	RPM	BHP	RPM	BHP	RPM	BHP	RPM	BHP
1900	826	0.36	859	0.41	894	0.45	928	0.50	964	0.56	1000	0.61	1036	0.66	1072	0.70
2000	857	0.42	889	0.47	920	0.52	952	0.57	986	0.62	1020	0.68	1055	0.73	1091	0.77
2100	878	0.49	909	0.54	940	0.59	973	0.64	1006	0.70	1041	0.75	1076	0.80	1112	0.85
2200	897	0.55	929	0.61	961	0.66	994	0.72	1028	0.78	1063	0.83	1099	0.89	1134	0.93
2300	918	0.62	950	0.68	983	0.74	1017	0.80	1052	0.86	1087	0.92	1122	0.97	1157	1.02
2400	941	0.70	974	0.77	1008	0.83	1042	0.90	1077	0.96	1111	1.01	1146	1.06	1181	1.11
2500	966	0.79	1000	0.86	1034	0.93	1068	1.00	1103	1.06	1137	1.11	1171	1.16	1205	1.20
2600	994	0.90	1028	0.97	1062	1.04	1096	1.10	1130	1.16	1164	1.21	1197	1.26	1231	1.30
2700	1023	1.01	1057	1.08	1091	1.15	1125	1.22	1159	1.27	1192	1.32	1225	1.37	1258	1.41
2800	1053	1.13	1088	1.21	1122	1.27	1155	1.33	1188	1.39	1221	1.43	1253	1.48	1286	1.53
2900	1085	1.26	1119	1.33	1153	1.40	1186	1.45	1218	1.51	1250	1.55	1281	1.61	1313	1.66

Air Volume cfm	External Static - in. w.g.															
	0.90		1.00		1.10		1.20		1.30		1.40		1.50		1.60	
	RPM	BHP	RPM	BHP	RPM	BHP	RPM	BHP	RPM	BHP	RPM	BHP	RPM	BHP	RPM	BHP
1900	1109	0.75	1146	0.79	1183	0.82	1221	0.86	1260	0.90	1294	0.94	1323	0.98	1349	1.02
2000	1128	0.82	1164	0.86	1201	0.89	1239	0.93	1276	0.97	1310	1.01	1336	1.06	1362	1.10
2100	1148	0.89	1185	0.93	1221	0.97	1258	1.01	1294	1.05	1325	1.09	1351	1.14	1376	1.19
2200	1170	0.97	1206	1.01	1242	1.05	1277	1.09	1311	1.14	1341	1.18	1365	1.23	1390	1.28
2300	1193	1.06	1228	1.09	1262	1.14	1295	1.19	1327	1.24	1355	1.29	1380	1.33	1406	1.37
2400	1216	1.15	1250	1.19	1282	1.24	1313	1.30	1343	1.36	1371	1.40	1396	1.44	1423	1.48
2500	1240	1.24	1273	1.29	1302	1.36	1331	1.42	1360	1.48	1388	1.52	1414	1.55	1441	1.58
2600	1265	1.34	1296	1.40	1324	1.47	1352	1.54	1381	1.60	1408	1.64	1434	1.67	1460	1.70
2700	1291	1.46	1321	1.52	1347	1.60	1374	1.67	1403	1.72	1429	1.76	1455	1.79	1481	1.82
2800	1317	1.58	1346	1.66	1372	1.74	1399	1.80	1426	1.85	1451	1.89	1477	1.92	1503	1.95
2900	1343	1.72	1371	1.80	1397	1.88	1424	1.95	1450	1.99	1475	2.02	1500	2.05	1526	2.08

BLOWER DATA

BELT DRIVE (TWO-SPEED) - 6 TON (HORIZONTAL)

LCX072S5T

BLOWER TABLE INCLUDES RESISTANCE FOR BASE UNIT ONLY WITH DRY INDOOR COIL AND AIR FILTERS IN PLACE.

FOR ALL UNITS ADD:

1 - Any factory installed options air resistance (economizer, wet coil, etc.) See page 32.

2 - Any field installed accessories air resistance (electric heat, duct resistance, diffuser, etc.) See page 32.

See page 32 for blower motors and drives.

Air Volume cfm	External Static - in. w.g.															
	0.10		0.20		0.30		0.40		0.50		0.60		0.70		0.80	
	RPM	BHP	RPM	BHP	RPM	BHP	RPM	BHP	RPM	BHP	RPM	BHP	RPM	BHP	RPM	BHP
1900	853	0.41	886	0.46	919	0.50	952	0.55	986	0.60	1021	0.64	1056	0.69	1091	0.73
2000	883	0.48	913	0.53	944	0.57	976	0.62	1009	0.67	1043	0.71	1078	0.76	1112	0.80
2100	906	0.56	936	0.60	967	0.65	999	0.70	1033	0.75	1067	0.79	1101	0.84	1135	0.88
2200	930	0.64	960	0.68	991	0.73	1024	0.78	1058	0.83	1092	0.88	1126	0.92	1160	0.96
2300	954	0.72	985	0.77	1017	0.82	1051	0.87	1085	0.92	1119	0.96	1152	1.00	1186	1.04
2400	981	0.81	1013	0.86	1046	0.91	1079	0.96	1113	1.00	1146	1.05	1180	1.09	1213	1.13
2500	1010	0.91	1042	0.96	1075	1.00	1109	1.05	1142	1.09	1175	1.14	1207	1.18	1239	1.23
2600	1040	1.01	1073	1.05	1106	1.10	1139	1.14	1171	1.19	1203	1.23	1235	1.28	1266	1.33
2700	1072	1.10	1104	1.15	1137	1.20	1169	1.24	1201	1.29	1232	1.34	1263	1.40	1293	1.46
2800	1105	1.21	1137	1.25	1168	1.30	1200	1.35	1231	1.40	1261	1.46	1291	1.52	1321	1.59
2900	1138	1.32	1169	1.37	1200	1.42	1231	1.47	1261	1.53	1291	1.60	1321	1.66	1350	1.73

Air Volume cfm	External Static - in. w.g.															
	0.90		1.00		1.10		1.20		1.30		1.40		1.50		1.60	
	RPM	BHP	RPM	BHP	RPM	BHP	RPM	BHP	RPM	BHP	RPM	BHP	RPM	BHP	RPM	BHP
1900	1126	0.77	1163	0.81	1200	0.85	1237	0.88	1273	0.92	1306	0.96	1339	1.00	1371	1.04
2000	1148	0.84	1183	0.88	1220	0.92	1257	0.96	1291	1.00	1323	1.04	1354	1.08	1385	1.12
2100	1170	0.92	1206	0.96	1242	1.00	1277	1.04	1310	1.08	1340	1.13	1371	1.17	1401	1.21
2200	1195	1.00	1230	1.04	1265	1.08	1299	1.13	1330	1.18	1359	1.23	1388	1.27	1418	1.31
2300	1220	1.08	1254	1.13	1288	1.17	1320	1.23	1350	1.28	1378	1.34	1406	1.38	1435	1.42
2400	1245	1.18	1278	1.22	1311	1.28	1341	1.33	1370	1.40	1397	1.45	1425	1.50	1454	1.54
2500	1271	1.28	1303	1.33	1334	1.39	1363	1.45	1391	1.52	1418	1.57	1446	1.62	1474	1.66
2600	1297	1.39	1328	1.45	1357	1.52	1385	1.58	1412	1.64	1439	1.70	1467	1.74	1495	1.78
2700	1323	1.52	1353	1.58	1382	1.65	1409	1.72	1435	1.77	1462	1.82	1490	1.86	1517	1.90
2800	1351	1.65	1380	1.72	1407	1.78	1434	1.85	1460	1.90	1486	1.95	1513	1.99	1541	2.02
2900	1379	1.79	1407	1.86	1434	1.92	1460	1.98	1485	2.04	1511	2.08	1538	2.12	1565	2.15

BLOWER DATA

BELT DRIVE KIT SPECIFICATIONS

Model No.	Motor HP		No. of Speeds	Drive Kits and RPM Range		
	Nominal	Maximum		A04	A07	A08
060	2	2.3	1	---	1212-1548	---
072	2	2.3	2	968-1340	---	1193-1591

NOTE - Using total air volume and system static pressure requirements determine from blower performance tables rpm and motor HP required. Maximum usable HP of motors furnished are shown. In Canada, nominal motor HP is also maximum usable motor HP. If motors of comparable HP are used, be sure to keep within the service factor limitations outlined on the motor nameplate.

OPTIONS / ACCESSORIES AIR RESISTANCE - in. w.g.

Air Volume cfm	Wet Indoor Coil		Reheat Coil		Economizer	Electric Heat	Filters		
	024, 036, 048, 060	072	024, 036, 048, 060	072			MERV 8	MERV 13	MERV 16
800	0.01	0.01	0.00	0.00	0.04	0.01	0.04	0.05	0.04
1000	0.02	0.01	0.00	0.00	0.04	0.03	0.04	0.07	0.05
1200	0.03	0.02	0.01	0.00	0.04	0.06	0.04	0.07	0.05
1400	0.04	0.03	0.02	0.01	0.04	0.09	0.04	0.07	0.06
1600	0.05	0.04	0.03	0.02	0.04	0.12	0.04	0.07	0.08
1800	0.06	0.05	0.04	0.02	0.05	0.15	0.05	0.07	0.09
2000	0.08	0.06	0.04	0.03	0.05	0.18	0.05	0.08	0.10
2200	0.09	0.07	---	0.04	0.05	0.20	0.05	0.08	0.11
2400	0.10	0.08	---	0.04	0.05	0.22	0.05	0.08	0.12

MINIMUM AIR VOLUME REQUIRED FOR ELECTRIC HEAT

Size	kW Size	Minimum CFM		
		Direct Drive	Belt Drive Downflow	Belt Drive Horizontal
024-060	5	600	N/A	N/A
	7.5	600	1,050	1,200
	10	600	N/A	N/A
	15	1100	1200	1300
	22.5	1600	1500	1600
072	30	N/A	1900	2000

BLOWER DATA

CEILING DIFFUSERS AIR RESISTANCE (in. w.g.)

Air Volume cfm	RTD9-65S Step-Down Diffuser			FD9-65S Flush Diffuser	RTD11-95S Step-Down Diffuser			FD11-95S Flush Diffuser
	2 Ends Open	1 Side & 2 Ends Open	All Ends & Sides Open		2 Ends Open	1 Side & 2 Ends Open	All Ends & Sides Open	
800	0.15	0.13	0.11	0.11	---	---	---	---
1000	0.19	0.16	0.14	0.14	---	---	---	---
1200	0.25	0.20	0.17	0.17	---	---	---	---
1400	0.33	0.26	0.20	0.20	---	---	---	---
1600	0.43	0.32	0.20	0.24	---	---	---	---
1800	0.56	0.40	0.30	0.30	0.13	0.11	0.09	0.09
2000	0.73	0.50	0.36	0.36	0.15	0.13	0.11	0.10
2200	0.95	0.63	0.44	0.44	0.18	0.15	0.12	0.12
2400	---	----	---	---	0.21	0.18	0.15	0.14
2600	---	----	---	---	0.24	0.21	0.18	0.17
2800	---	----	---	---	0.27	0.24	0.21	0.20
3000	---	----	---	---	0.32	0.29	0.25	0.25

CEILING DIFFUSER AIR THROW DATA

Air Volume - cfm	¹ Effective Throw - ft.	
	RTD9-65S	FD9-65S
800	10 - 17	14 - 18
1000	10 - 17	15 - 20
1200	11 - 18	16 - 22
1400	12 - 19	17 - 24
1600	12 - 20	18 - 25
1800	13 - 21	20 - 28
2000	14 - 23	21 - 29
2200	16 - 25	22 - 30
Model	RTD11-95S	FD11-95S
2600	24 - 29	19 - 24
2800	25 - 30	20 - 28
3000	27 - 33	21 - 29

¹ Effective throw based on terminal velocities of 75 ft. per minute.

POWER EXHAUST FAN PERFORMANCE

Return Air System Static Pressure - in. w.g.	Air Volume Exhausted cfm
0.00	2000
0.05	1990
0.10	1924
0.15	1810
0.20	1664
0.25	1507
0.30	1350
0.35	1210

OUTDOOR SOUND DATA

Size	Octave Band Sound Power Levels dBA, re 10 ⁻¹² Watts - Center Frequency - Hz							¹ Sound Rating Number (dBA)
	125	250	500	1000	2000	4000	8000	
024, 036, 048, 060	62	66	70	69	66	60	50	74
072	66	71	74	73	70	65	57	79

Note - The octave sound power data does not include tonal corrections.

¹ Sound Rating Number according to AHRI Standard 270-95 (includes pure tone penalty). Sound Rating Number is the overall A-Weighted Sound Power Level, (LWA), dBA (100 Hz to 10,000 Hz).

ELECTRICAL/ELECTRIC HEAT DATA			DIRECT DRIVE - 2 TON [PSC]
Model			LCX024S5D
¹ Voltage - 60Hz			208/230V - 1 Ph
Compressor 1 (Non-Inverter)	Rated Load Amps		10.3
	Locked Rotor Amps		60.2
Outdoor Fan Motors (1)	Full Load Amps (1 Non-ECM)		1.7
Service Outlet 115V GFI (amps)			15
Indoor Blower Motor	HP		0.25
	Type		Direct
	Full Load Amps		1.7
² Maximum Overcurrent Protection (MOCP)	Unit Only		25
	with (1) 0.33 HP Power Exhaust		25
³ Minimum Circuit Ampacity (MCA)	Unit Only		17
	with (1) 0.33 HP Power Exhaust		19

ELECTRIC HEAT DATA				208V	240V
Electric Heat Voltage					
² Maximum Overcurrent Protection (MOCP)	Unit + Electric Heat	5 kW		25	30
		7.5 kW		40	45
		10 kW		50	60
³ Minimum Circuit Ampacity (MCA)	Unit + Electric Heat	5 kW		25	29
		7.5 kW		36	42
		10 kW		48	55
² Maximum Overcurrent Protection (MOCP)	Unit + Electric Heat + Power Exhaust	5 kW		30	35
		7.5 kW		40	45
		10 kW		60	60
³ Minimum Circuit Ampacity (MCA)	Unit + Electric Heat + Power Exhaust	5 kW		28	32
		7.5 kW		39	45
		10 kW		51	58

ELECTRICAL ACCESSORIES				20W21	20W21
Disconnect		0-10 kW			

Disconnects - 20W21 - 80A

NOTE - All units have a minimum Short Circuit Current Rating (SCCR) of 5000 amps.

¹ Extremes of operating range are plus and minus 10% of line voltage.

² HACR type breaker or fuse.

³ Refer to National or Canadian Electrical Code manual to determine wire, fuse and disconnect size requirements.

ELECTRICAL/ELECTRIC HEAT DATA
DIRECT DRIVE - 3 TON [PSC]

Model		LCX036S5D			
¹ Voltage - 60Hz		208/230V - 1 Ph	208/230V - 3 Ph	460V - 3 Ph	575V - 3 Ph
Compressor 1 (Non-Inverter)	Rated Load Amps	14.4	9	4.1	3.3
	Locked Rotor Amps	86	70	39	29
Outdoor Fan Motor	Full Load Amps (1 Non-ECM)	1.7	1.7	1.1	0.7
Power Exhaust (1) 0.33 HP	Full Load Amps	2.4	2.4	1.3	1
Service Outlet 115V GFI (amps)		15	15	15	20
Indoor Blower Motor	HP	0.5	0.5	0.5	0.5
	Type	Direct	Direct	Direct	Direct
	Full Load Amps	3.1	3.1	1.5	1.5
² Maximum Overcurrent Protection (MOCP)	Unit Only	35	25	15	15
	with (1) 0.33 HP Power Exhaust	35	25	15	15
³ Minimum Circuit Ampacity (MCA)	Unit Only	23	17	8	7
	with (1) 0.33 HP Power Exhaust	26	19	10	8

ELECTRIC HEAT DATA

Electric Heat Voltage			208V	240V	208V	240V	480V	600V
² Maximum Overcurrent Protection (MOCP)	Unit + Electric Heat	7.5 kW	40	45	25	30	15	15
		15 kW	80	90	45	50	25	20
³ Minimum Circuit Ampacity (MCA)	Unit + Electric Heat	7.5 kW	38	43	24	27	14	11
		15 kW	72	82	43	49	25	20
² Maximum Overcurrent Protection (MOCP)	Unit + Electric Heat + Power Exhaust	7.5 kW	45	50	30	30	15	15
		15 kW	80	90	50	60	30	25
³ Minimum Circuit Ampacity (MCA)	Unit + Electric Heat + Power Exhaust	7.5 kW	41	46	27	30	15	13
		15 kW	75	85	46	52	27	22

ELECTRICAL ACCESSORIES

Disconnect	0-7.5 kW 15 kW	20W21	20W21	20W21	20W21	20W21	20W21
			20W21	20W22	20W21	20W21	20W21

Disconnects - 20W21 - 80A
20W22 - 150A

NOTE - All units have a minimum Short Circuit Current Rating (SCCR) of 5000 amps.

¹ Extremes of operating range are plus and minus 10% of line voltage.

² HACR type breaker or fuse.

³ Refer to National or Canadian Electrical Code manual to determine wire, fuse and disconnect size requirements.

ELECTRICAL/ELECTRIC HEAT DATA
DIRECT DRIVE - 4 TON [PSC]

Model		LCX048S5D			
¹ Voltage - 60Hz		208/230V - 1 Ph	208/230V - 3 Ph	460V - 3 Ph	575V - 3 Ph
Compressor 1 (Non-Inverter)	Rated Load Amps	19.4	12	6.3	4.4
	Locked Rotor Amps	102	123	60	41
Outdoor Fan Motor	Full Load Amps (1 Non-ECM)	1.7	1.7	1.1	0.7
Power Exhaust (1) 0.33 HP	Full Load Amps	2.4	2.4	1.3	1
Service Outlet 115V GFI (amps)		15	15	15	20
Indoor Blower Motor	HP	0.5	0.5	0.5	0.5
	Type	Direct	Direct	Direct	Direct
	Full Load Amps	3.1	3.1	1.5	1.5
² Maximum Overcurrent Protection (MOCP)	Unit Only	45	30	15	15
	with (1) 0.33 HP Power Exhaust	50	30	15	15
³ Minimum Circuit Ampacity (MCA)	Unit Only	30	20	11	8
	with (1) 0.33 HP Power Exhaust	32	23	12	9

ELECTRIC HEAT DATA

Electric Heat Voltage			208V	240V	208V	240V	480V	600V
² Maximum Overcurrent Protection (MOCP)	Unit + Electric Heat	7.5 kW	45	45	30	30	15	15
		15 kW	80	90	45	50	25	20
³ Minimum Circuit Ampacity (MCA)	Unit + Electric Heat	7.5 kW	38	43	24	27	14	11
		15 kW	72	82	43	49	25	20
² Maximum Overcurrent Protection (MOCP)	Unit + Electric Heat + Power Exhaust	7.5 kW	50	50	30	30	15	15
		15 kW	80	90	50	60	30	25
³ Minimum Circuit Ampacity (MCA)	Unit + Electric Heat + Power Exhaust	7.5 kW	41	46	27	30	15	13
		15 kW	75	85	46	52	27	22

ELECTRICAL ACCESSORIES

Disconnect	0-7.5 kW	20W21	20W21	20W21	20W21	20W21	20W21
	15 kW	20W21	20W22	20W21	20W21	20W21	20W21

Disconnects - 20W21 - 80A
20W22 - 150A

NOTE - All units have a minimum Short Circuit Current Rating (SCCR) of 5000 amps.

¹ Extremes of operating range are plus and minus 10% of line voltage.

² HACR type breaker or fuse.

³ Refer to National or Canadian Electrical Code manual to determine wire, fuse and disconnect size requirements.

ELECTRICAL/ELECTRIC HEAT DATA
DIRECT DRIVE - 3 TON [ECM]

Model		LCX036S5E			
¹ Voltage - 60Hz		208/230V - 1 Ph	208/230V - 3 Ph	460V - 3 Ph	575V - 3 Ph
Compressor 1 (Non-Inverter)	Rated Load Amps	14.4	9	4.1	3.3
	Locked Rotor Amps	86	70	39	29
Outdoor Fan Motor	Full Load Amps (1 Non-ECM)	1.7	1.7	1.1	0.7
Power Exhaust (1) 0.33 HP	Full Load Amps	2.4	2.4	1.3	1
Service Outlet 115V GFI (amps)		15	15	15	20
Indoor Blower Motor	HP	1	1	1	1
	Type	Direct	Direct	Direct	Direct
	Full Load Amps	7.4	7.4	3.7	3
² Maximum Overcurrent Protection (MOCP)	Unit Only	40	25	15	15
	with (1) 0.33 HP Power Exhaust	40	30	15	15
³ Minimum Circuit Ampacity (MCA)	Unit Only	28	21	10	8
	with (1) 0.33 HP Power Exhaust	30	23	12	9

ELECTRIC HEAT DATA

Electric Heat Voltage			208V	240V	208V	240V	480V	600V
² Maximum Overcurrent Protection (MOCP)	Unit + Electric Heat	7.5 kW	45	50	30	35	20	15
		15 kW	80	90	50	60	30	25
³ Minimum Circuit Ampacity (MCA)	Unit + Electric Heat	7.5 kW	44	49	29	32	16	13
		15 kW	77	88	49	55	28	22
² Maximum Overcurrent Protection (MOCP)	Unit + Electric Heat + Power Exhaust	7.5 kW	50	60	35	35	20	15
		15 kW	80	100	60	60	30	25
³ Minimum Circuit Ampacity (MCA)	Unit + Electric Heat + Power Exhaust	7.5 kW	47	52	32	35	18	15
		15 kW	80	91	52	58	29	24

ELECTRICAL ACCESSORIES

Disconnect	0-7.5 kW 15 kW	20W21	20W21	20W21	20W21	20W21	20W21
			20W21	20W22	20W21	20W21	20W21

Disconnects - 20W21 - 80A
20W22 - 150A

NOTE - All units have a minimum Short Circuit Current Rating (SCCR) of 5000 amps.

¹ Extremes of operating range are plus and minus 10% of line voltage.

² HACR type breaker or fuse.

³ Refer to National or Canadian Electrical Code manual to determine wire, fuse and disconnect size requirements.

ELECTRICAL/ELECTRIC HEAT DATA
DIRECT DRIVE - 4 TON [ECM]

Model		LCX048S5E			
¹ Voltage - 60Hz		208/230V - 1 Ph	208/230V - 3 Ph	460V - 3 Ph	575V - 3 Ph
Compressor 1 (Non-Inverter)	Rated Load Amps	19.4	12	6.3	4.4
	Locked Rotor Amps	102	123	60	41
Outdoor Fan Motor	Full Load Amps (1 Non-ECM)	1.7	1.7	1.1	0.7
Power Exhaust (1) 0.33 HP	Full Load Amps	2.4	2.4	1.3	1
Service Outlet 115V GFI (amps)		15	15	15	20
Indoor Blower Motor	HP	1	1	1	1
	Type	Direct	Direct	Direct	Direct
	Full Load Amps	7.4	7.4	3.7	3
² Maximum Overcurrent Protection (MOCP)	Unit Only	50	35	15	15
	with (1) 0.33 HP Power Exhaust	50	35	20	15
³ Minimum Circuit Ampacity (MCA)	Unit Only	34	25	13	10
	with (1) 0.33 HP Power Exhaust	36	27	14	11

ELECTRIC HEAT DATA

Electric Heat Voltage			208V	240V	208V	240V	480V	600V
² Maximum Overcurrent Protection (MOCP)	Unit + Electric Heat	7.5 kW	50	50	35	35	20	15
		15 kW	80	90	50	60	30	25
³ Minimum Circuit Ampacity (MCA)	Unit + Electric Heat	7.5 kW	44	49	29	32	16	13
		15 kW	77	88	49	55	28	22
² Maximum Overcurrent Protection (MOCP)	Unit + Electric Heat + Power Exhaust	7.5 kW	50	60	35	35	20	15
		15 kW	80	100	60	60	30	25
³ Minimum Circuit Ampacity (MCA)	Unit + Electric Heat + Power Exhaust	7.5 kW	47	52	32	35	18	15
		15 kW	80	91	52	58	29	24

ELECTRICAL ACCESSORIES

Disconnect	0-7.5 kW	20W21	20W21	20W21	20W21	20W21	20W21
	15 kW	20W21	20W22	20W21	20W21	20W21	20W21

Disconnects - 20W21 - 80A
20W22 - 150A

NOTE - All units have a minimum Short Circuit Current Rating (SCCR) of 5000 amps.

¹ Extremes of operating range are plus and minus 10% of line voltage.

² HACR type breaker or fuse.

³ Refer to National or Canadian Electrical Code manual to determine wire, fuse and disconnect size requirements.

ELECTRICAL/ELECTRIC HEAT DATA
DIRECT DRIVE - 5 TON [ECM]

Model		LCX060S5E			
¹ Voltage - 60Hz		208/230V - 1 Ph	208/230V - 3 Ph	460V - 3 Ph	575V - 3 Ph
Compressor 1 (Non-Inverter)	Rated Load Amps	23.7	16	7.1	6.4
	Locked Rotor Amps	157	156.4	69	47.8
Outdoor Fan Motor	Full Load Amps (1 Non-ECM)	1.7	1.7	1.1	0.7
Power Exhaust (1) 0.33 HP	Full Load Amps	2.4	2.4	1.3	1
Service Outlet 115V GFI (amps)		15	15	15	20
Indoor Blower Motor	HP	1	1	1	1
	Type	Direct	Direct	Direct	Direct
	Full Load Amps	7.4	7.4	3.7	3
² Maximum Overcurrent Protection (MOCP)	Unit Only	60	45	20	15
	with (1) 0.33 HP Power Exhaust	60	45	20	15
³ Minimum Circuit Ampacity (MCA)	Unit Only	39	30	14	12
	with (1) 0.33 HP Power Exhaust	42	32	15	13

ELECTRIC HEAT DATA

Electric Heat Voltage			208V	240V	208V	240V	480V	600V
² Maximum Overcurrent Protection (MOCP)	Unit +	7.5 kW	60	60	45	45	20	15
	Electric Heat	15 kW	80	90	50	60	30	25
		22.5 kW	125	150	70	80	40	35
³ Minimum Circuit Ampacity (MCA)	Unit +	7.5 kW	44	49	30	32	16	13
	Electric Heat	15 kW	77	88	49	55	28	22
		22.5 kW	111	127	68	77	39	31
² Maximum Overcurrent Protection (MOCP)	Unit +	7.5 kW	60	60	45	45	20	15
	Electric Heat + Power Exhaust	15 kW	80	100	60	60	30	25
		22.5 kW	125	150	80	80	45	35
³ Minimum Circuit Ampacity (MCA)	Unit +	7.5 kW	47	52	32	35	18	15
	Electric Heat + Power Exhaust	15 kW	80	91	52	58	29	24
		22.5 kW	114	130	71	80	41	33

ELECTRICAL ACCESSORIES

Disconnect	0-7.5 kW	20W21	20W21	20W21	20W21	20W21	20W21
	15 kW	20W21	20W22	20W21	20W21	20W21	20W21
	22.5 kW	20W22	20W22	20W21	20W21	20W21	20W21

Disconnects - 20W21 - 80A
20W22 - 150A

NOTE - All units have a minimum Short Circuit Current Rating (SCCR) of 5000 amps.

¹ Extremes of operating range are plus and minus 10% of line voltage.

² HACR type breaker or fuse.

³ Refer to National or Canadian Electrical Code manual to determine wire, fuse and disconnect size requirements.

ELECTRICAL/ELECTRIC HEAT DATA **BELT DRIVE (SINGLE SPEED) - 5 TON**

Model		LCX060S5B		
¹ Voltage - 60Hz		208/230V - 3 Ph	460V - 3 Ph	575V - 3 Ph
Compressor 1 (Non-Inverter)	Rated Load Amps	16	7.1	6.4
	Locked Rotor Amps	156.4	69	47.8
Outdoor Fan Motor	Full Load Amps (1 Non-ECM)	1.7	1.1	0.7
Power Exhaust (1) 0.33 HP	Full Load Amps	2.4	1.3	1
Service Outlet 115V GFI (amps)		15	15	20
Indoor Blower Motor	HP	2	2	2
	Type	Belt	Belt	Belt
	Full Load Amps	7.5	3.4	2.7
² Maximum Overcurrent Protection (MOCP)	Unit Only	45	20	15
	with (1) 0.33 HP Power Exhaust	45	20	15
³ Minimum Circuit Ampacity (MCA)	Unit Only	30	14	12
	with (1) 0.33 HP Power Exhaust	32	15	13

ELECTRIC HEAT DATA

Electric Heat Voltage			208V	240V	480V	600V
² Maximum Overcurrent Protection (MOCP)	Unit + Electric Heat	7.5 kW	45	45	20	15
		15 kW	50	60	30	25
		22.5 kW	70	80	40	35
³ Minimum Circuit Ampacity (MCA)	Unit + Electric Heat	7.5 kW	30	32	16	13
		15 kW	49	55	27	22
		22.5 kW	69	78	39	31
² Maximum Overcurrent Protection (MOCP)	Unit + Electric Heat + Power Exhaust	7.5 kW	45	45	20	15
		15 kW	60	60	30	25
		22.5 kW	80	90	40	35
³ Minimum Circuit Ampacity (MCA)	Unit + Electric Heat + Power Exhaust	7.5 kW	32	35	18	14
		15 kW	52	58	29	23
		22.5 kW	72	81	40	32

ELECTRICAL ACCESSORIES

Disconnect	0-7.5 kW	20W21	20W21	20W21	20W21
	15 kW	20W21	20W21	20W21	20W21
	22.5 kW	20W21	⁴ 20W21/ ⁵ 20W22	20W21	20W21

Disconnects - 20W21 - 80A
20W22 - 150A

NOTE - All units have a minimum Short Circuit Current Rating (SCCR) of 5000 amps.

¹ Extremes of operating range are plus and minus 10% of line voltage.

² HACR type breaker or fuse.

³ Refer to National or Canadian Electrical Code manual to determine wire, fuse and disconnect size requirements.

⁴ Without Power Exhaust.

⁵ With Power Exhaust.

FIELD WIRING NOTES

- For use with copper wiring only
- Field wiring not furnished
- All wiring must conform to NEC or CEC and local electrical codes
- For specific wiring information, please refer to the installation instructions

ELECTRICAL/ELECTRIC HEAT DATA
BELT DRIVE (TWO SPEED) - 6 TON
Model
LCX072S5T

¹ Voltage - 60Hz		208/230V - 3 Ph	460V - 3 Ph	575V - 3 Ph
Compressor 1 (Non-Inverter)	Rated Load Amps	19.2	9.1	6.2
	Locked Rotor Amps	162.3	70.8	58.2
Outdoor Fan Motor	Full Load Amps (1 Non-ECM)	2.4	1.3	1
Power Exhaust (1) 0.33 HP	Full Load Amps	2.4	1.3	1
Service Outlet 115V GFI (amps)		15	15	20
Indoor Blower Motor	HP	2	2	2
	Type	Belt	Belt	Belt
	Full Load Amps	7.5	3.4	2.7
² Maximum Overcurrent Protection (MOCP)	Unit Only	50	25	15
	with (1) 0.33 HP Power Exhaust	50	25	15
³ Minimum Circuit Ampacity (MCA)	Unit Only	34	17	12
	with (1) 0.33 HP Power Exhaust	37	18	13

ELECTRIC HEAT DATA

Electric Heat Voltage			208V	240V	480V	600V
² Maximum Overcurrent Protection (MOCP)	Unit + Electric Heat	7.5 kW	50	50	25	15
		15 kW	50	60	30	25
		22.5 kW	70	80	40	35
		30 kW	90	100	50	40
³ Minimum Circuit Ampacity (MCA)	Unit + Electric Heat	7.5 kW	34	34	17	13
		15 kW	49	55	27	22
		22.5 kW	69	78	39	31
		30 kW	88	100	50	40
² Maximum Overcurrent Protection (MOCP)	Unit + Electric Heat + Power Exhaust	7.5 kW	50	50	25	15
		15 kW	60	60	30	25
		22.5 kW	80	90	40	35
		30 kW	100	110	60	45
³ Minimum Circuit Ampacity (MCA)	Unit + Electric Heat + Power Exhaust	7.5 kW	37	37	18	14
		15 kW	52	58	29	23
		22.5 kW	72	81	40	32
		30 kW	91	103	51	41

ELECTRICAL ACCESSORIES

Disconnect	0-15 kW	22A23	22A23	22A23	22A23
	22.5 kW	22A23	⁴ 22A23/ ⁵ 22A24	22A23	22A23
	30 kW	22A24	22A24	22A23	22A23

**Disconnects - 22A23 - 80A
22A24 - 150A**

NOTE - All units have a minimum Short Circuit Current Rating (SCCR) of 5000 amps.

¹ Extremes of operating range are plus and minus 10% of line voltage.

² HACR type breaker or fuse.

³ Refer to National or Canadian Electrical Code manual to determine wire, fuse and disconnect size requirements.

⁴ Without Power Exhaust.

⁵ With Power Exhaust.

ELECTRIC HEAT CAPACITIES

Input Voltage	5 kW			7.5 kW			10 kW		
	Stages	kW input	Btuh Output	Stages	kW input	Btuh Output	Stages	kW input	Btuh Output
208	1	3.8	12,800	1	5.6	19,200	1	7.5	25,600
220	1	4.2	14,300	1	6.3	21,500	1	8.4	28,700
230	1	4.6	15,700	1	6.9	23,500	1	9.2	31,400
240	1	5.0	17,100	1	7.5	25,600	1	10.0	34,200
440	---	---	---	1	6.3	21,500	---	---	---
460	---	---	---	1	6.9	23,500	---	---	---
480	---	---	---	1	7.5	25,600	---	---	---
550	---	---	---	1	6.3	21,500	---	---	---
575	---	---	---	1	6.9	23,500	---	---	---
600	---	---	---	1	7.5	25,600	---	---	---

Input Voltage	15 kW			22.5 kW			30 kW		
	Stages	kW input	Btuh Output	Stages	kW input	Btuh Output	Stages	kW input	Btuh Output
208	1	11.2	38,400	1	16.9	57,700	1	22.5	76,800
220	1	12.6	43,000	1	18.9	64,500	1	25.2	86,000
230	1	13.8	47,000	1	20.7	70,700	1	27.5	93,900
240	1	15.0	51,200	1	22.5	76,800	1	30.0	102,400
440	1	12.6	43,000	1	18.9	64,500	1	25.2	86,000
460	1	13.8	47,000	1	20.7	70,700	1	27.5	93,900
480	1	15.0	51,200	1	22.5	76,800	1	30.0	102,400
550	1	12.6	43,000	1	18.9	64,500	1	25.2	86,000
575	1	13.8	47,000	1	20.7	70,700	1	27.5	93,900
600	1	15.0	51,200	1	22.5	76,800	1	30.0	102,400

UNIT CLEARANCES

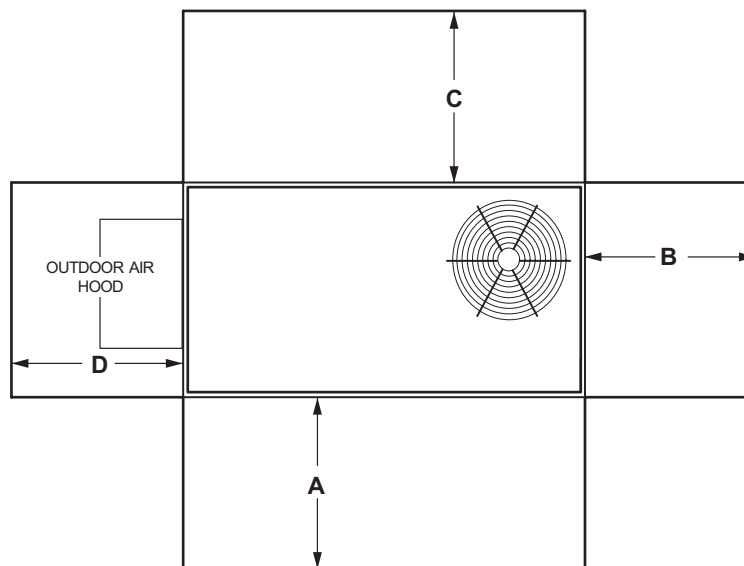

¹ Unit Clearance	A		B		C		D		Top Clearance
	in.	mm	in.	mm	in.	mm	in.	mm	
Service Clearance	36	914	36	914	36	914	36	914	Unobstructed
Minimum Operation Clearance	36	914	36	914	36	914	36	914	

NOTE - Entire perimeter of unit base requires support when elevated above the mounting surface.

¹ Service Clearance - Required for removal of serviceable parts.

Minimum Operation Clearance - Required clearance for proper unit operation.

WEIGHT DATA

Size	Net		Shipping	
	lbs.	kg	lbs.	kg
024 Base Unit	502	228	534	242
024 Max. Unit	597	271	638	289
036 Base Unit	504	229	545	247
036 Max. Unit	631	286	672	305
048 Base Unit	504	229	545	247
048 Max. Unit	631	286	672	305
060 Base Unit	504	229	545	247
060 Max. Unit	631	286	672	305
072 Base Unit	575	261	616	279
072 Max. Unit	676	307	717	325

FACTORY / FIELD INSTALLED OPTIONS AND ACCESSORIES - NET WEIGHTS

Description	lbs.	kg	
ECONOMIZER / OUTDOOR AIR / POWER EXHAUST			
Economizer			
High Performance Economizer - Includes Barometric Relief Dampers and Combination Hood	84	38	
Outdoor Air Dampers			
Motorized	40	18	
Manual	30	14	
Power Exhaust	35	16	
ELECTRIC HEAT			
5 kW	31	14	
7.5 kW	31	14	
10 kW	31	14	
15 kW	31	14	
22.5 kW	35	16	
30 kW	35	16	
COMBINATION COIL/HAIL GUARDS			
All models	30	14	
ROOF CURBS			
Hybrid Roof Curbs, Downflow			
8 in. height	86	39	
14 in. height	108	49	
18 in. height	125	57	
24 in. height	147	67	
Adjustable Pitch Curb, Downflow			
14 in. height	147	67	
CEILING DIFFUSERS			
Step-Down	RTD9-65S	80	36
	RTD11-95S	118	54
Flush	FD9-65S	80	36
	FD11-95S	118	54
Transitions (Supply and Return)	T1TRAN10AN1	22	10
	T1TRAN20N-1	21	10
HUMIDITROL® DEHUMIDIFICATION SYSTEM			
Humiditrol Dehumidification Option	27	12	

DIMENSIONS - UNIT

Size	CORNER WEIGHTS								CENTER OF GRAVITY															
	AA		BB		CC		DD		EE		FF		FF											
	Base	Max.	Base	Max.	Base	Max.	Base	Max.	Base	Max.	Base	Max.	Base	Max.										
	lbs.	kg	lbs.	kg	lbs.	kg	lbs.	kg	lbs.	kg	in.	mm	in.	mm	in.	mm								
024	101	46	122	56	118	53	125	57	152	69	161	73	131	60	197	90	39-1/2	1003	45	1143	20-1/2	521	20-1/2	521
036	107	48	132	60	123	56	131	60	159	72	177	80	138	62	213	97	39-1/2	1003	45	1143	20-1/2	521	20	508
048	107	48	132	60	123	56	131	60	159	72	177	81	138	62	213	97	39-1/2	1003	45	1143	20-1/2	521	20	508
060	107	48	132	60	123	56	131	60	159	72	177	81	138	62	213	97	39-1/2	1003	45	1143	20-1/2	521	20	508
072	118	53	142	65	140	63	152	69	197	89	205	93	166	75	251	114	39	991	44-3/4	1137	19-1/2	495	20	508

Base Unit - The unit with NO INTERNAL OPTIONS.

Max. Unit - The unit with ALL INTERNAL OPTIONS Installed. (Economizer, Standard Static Power Exhaust Fans, Controls, etc.). Does not include accessories external to unit or high static power exhaust.

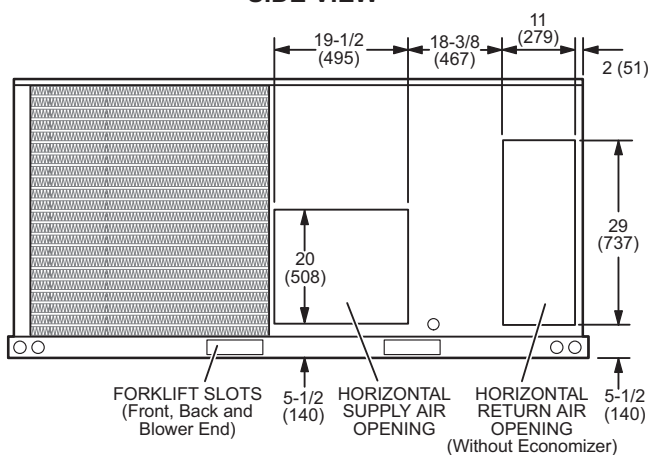
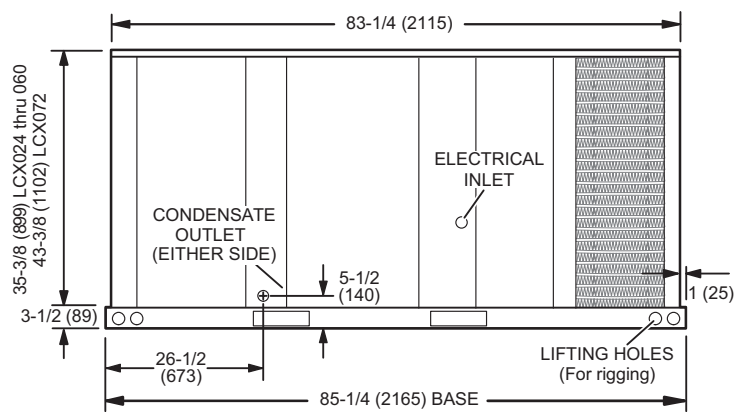
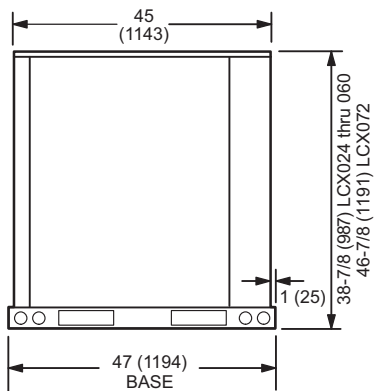
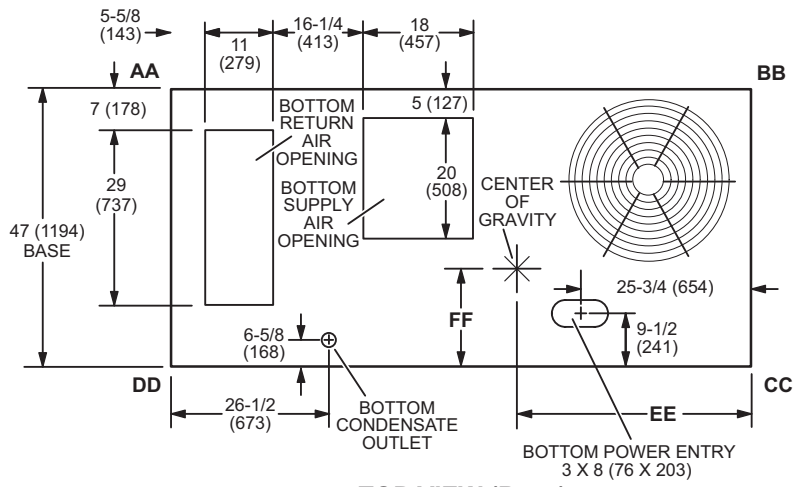

DIMENSIONS - ACCESSORIES

COMBINATION OUTDOOR AIR HOOD DETAIL FOR OPTIONAL ECONOMIZER AND BAROMETRIC RELIEF DAMPERS (Furnished With Economizer for Downflow Applications)

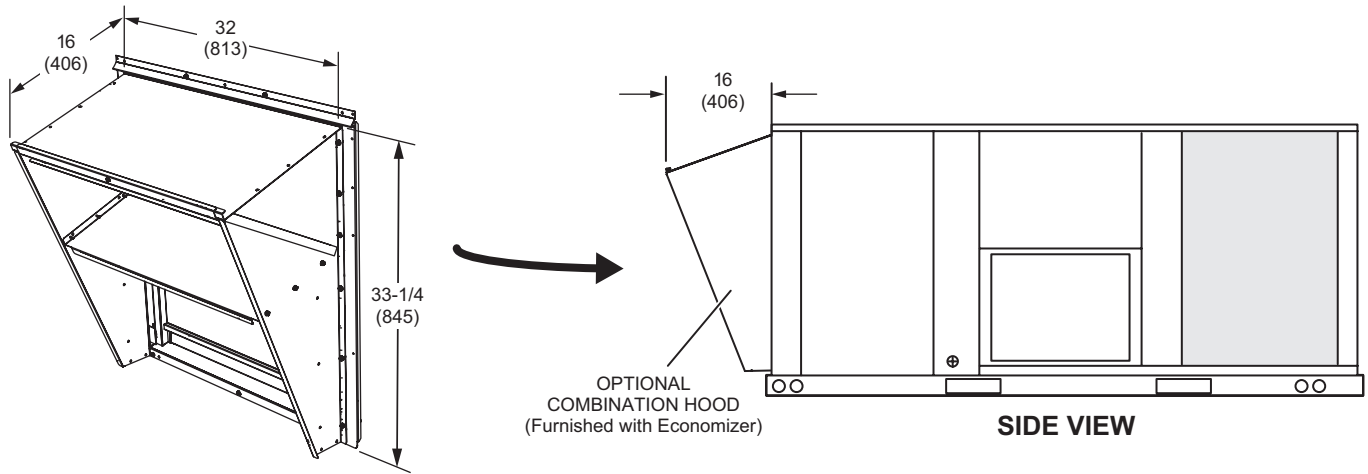

OUTDOOR AIR DAMPER HOOD DETAIL (Downflow or Horizontal Applications)

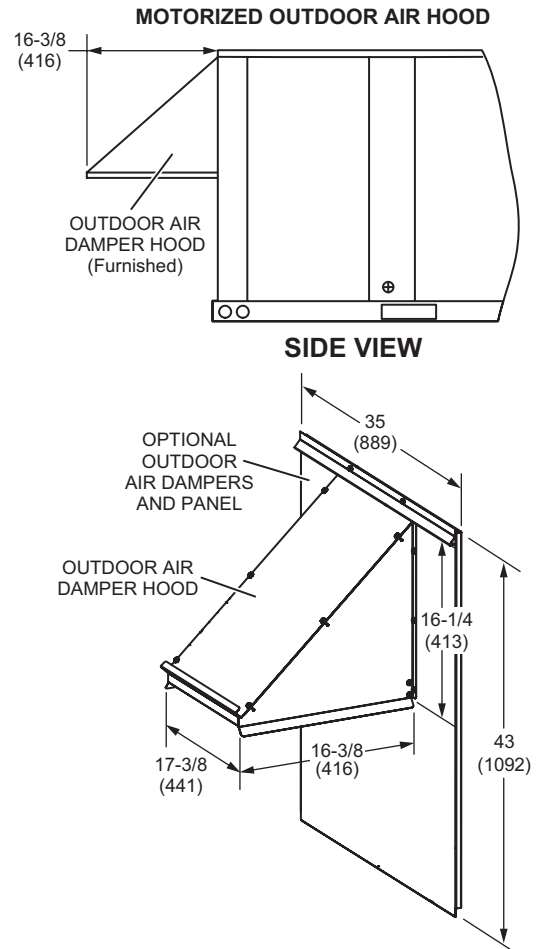
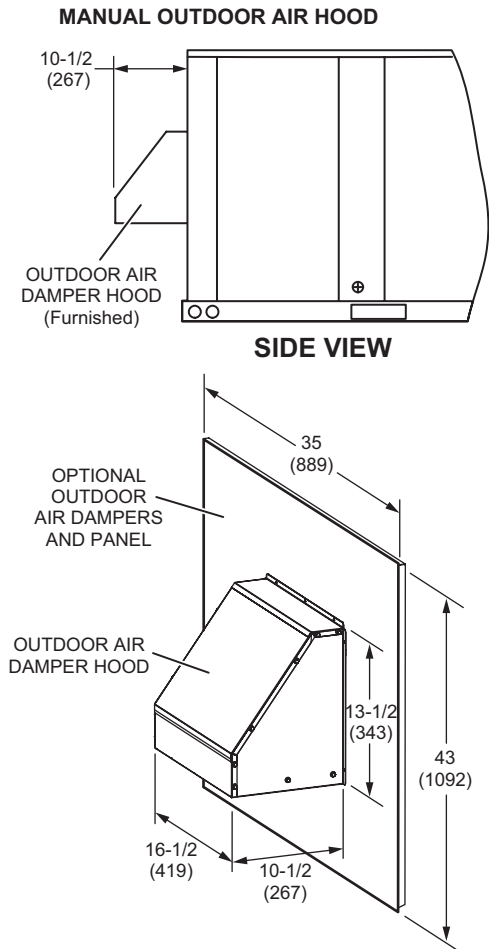

DIMENSIONS - ACCESSORIES

HORIZONTAL ECONOMIZER APPLICATIONS - OUTDOOR AIR HOOD DETAIL WITH OPTIONAL ECONOMIZER DAMPERS AND OPTIONAL HORIZONTAL BAROMETRIC RELIEF DAMPERS AND HOOD

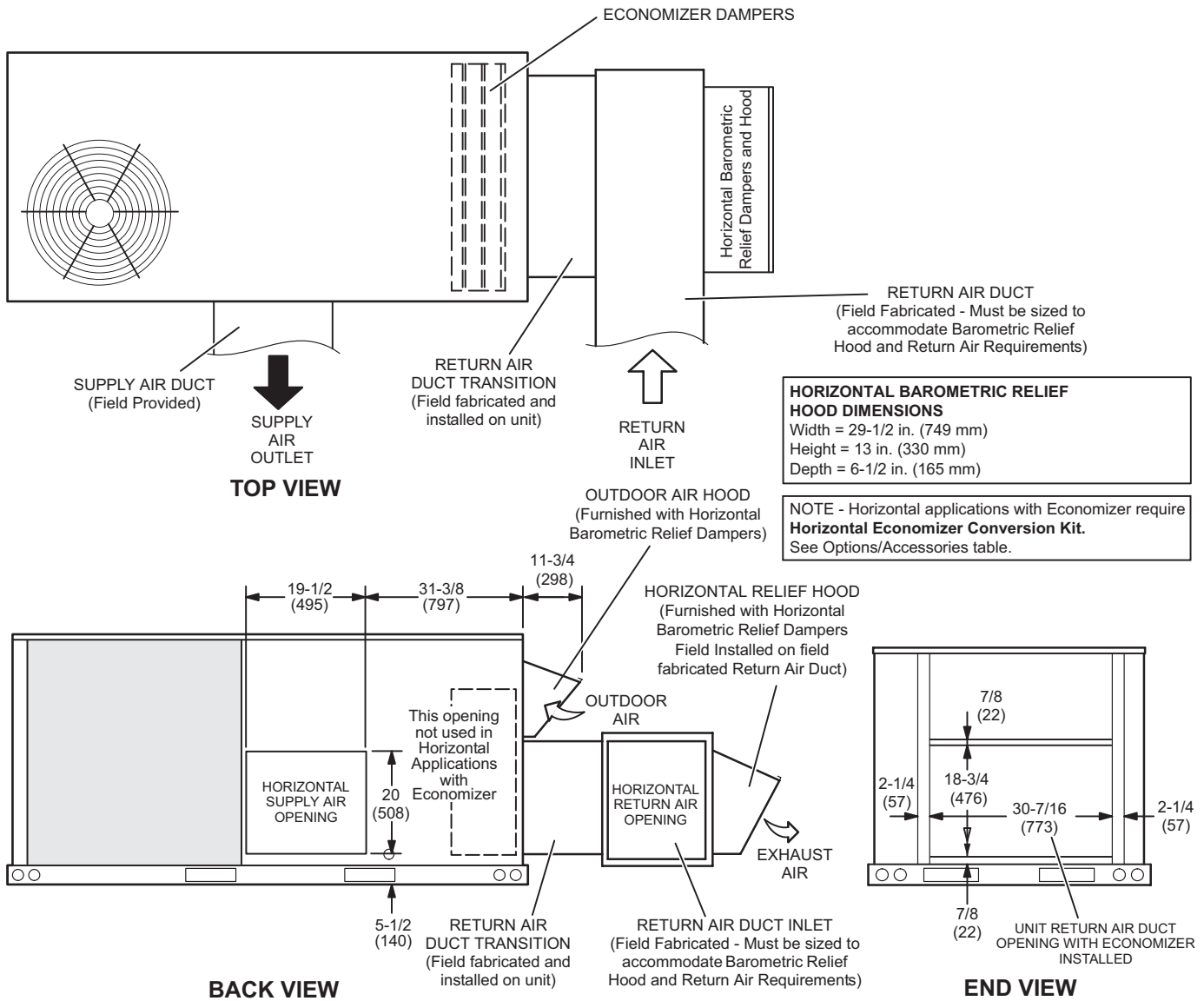

NOTE - Return Air Duct and Transition must be supported.

DIMENSIONS - ACCESSORIES

HYBRID ROOF CURBS - DOUBLE DUCT OPENING

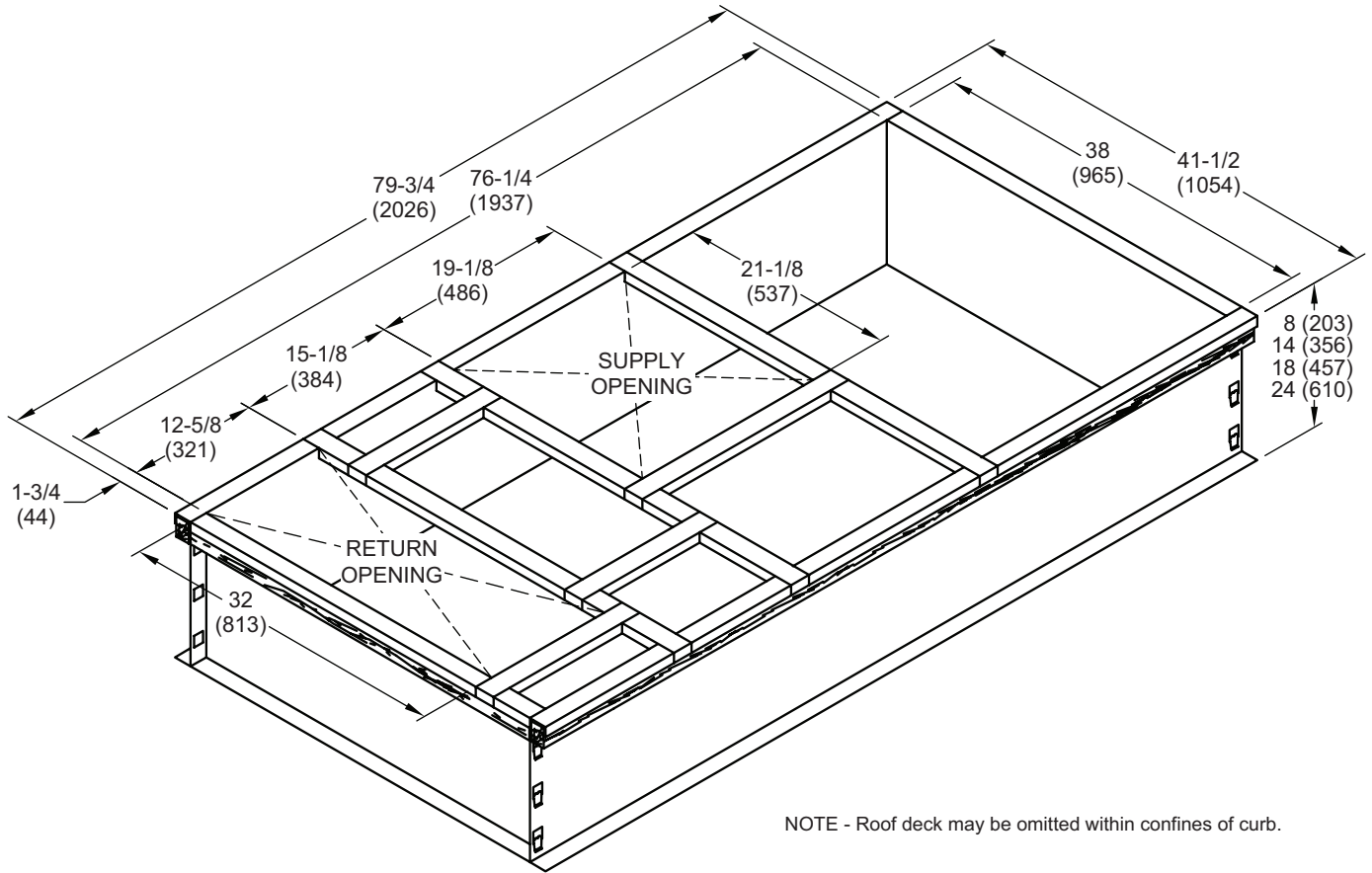

TYPICAL FLASHING DETAIL FOR ROOF CURB

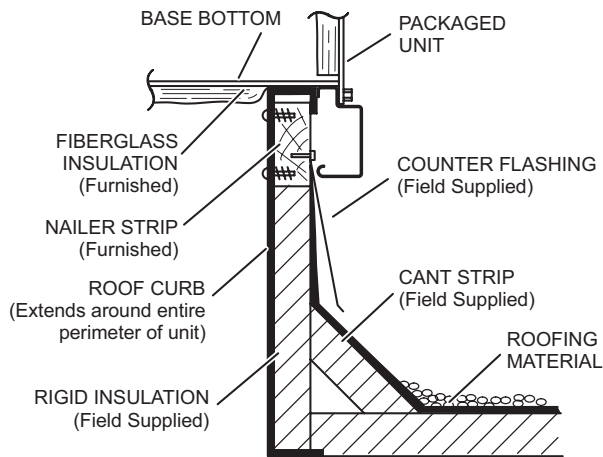

DETAIL ROOF CURB

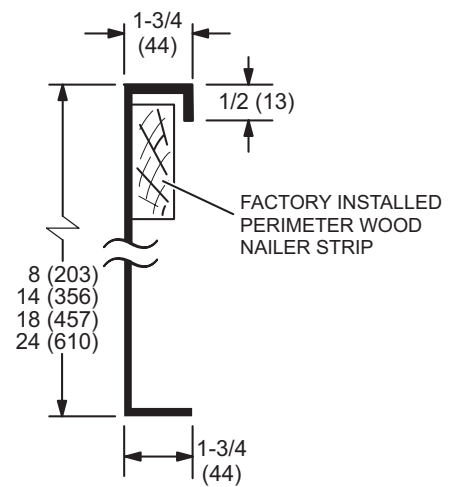

DIMENSIONS - ACCESSORIES

ADJUSTABLE PITCH CURBS - DOUBLE DUCT OPENING

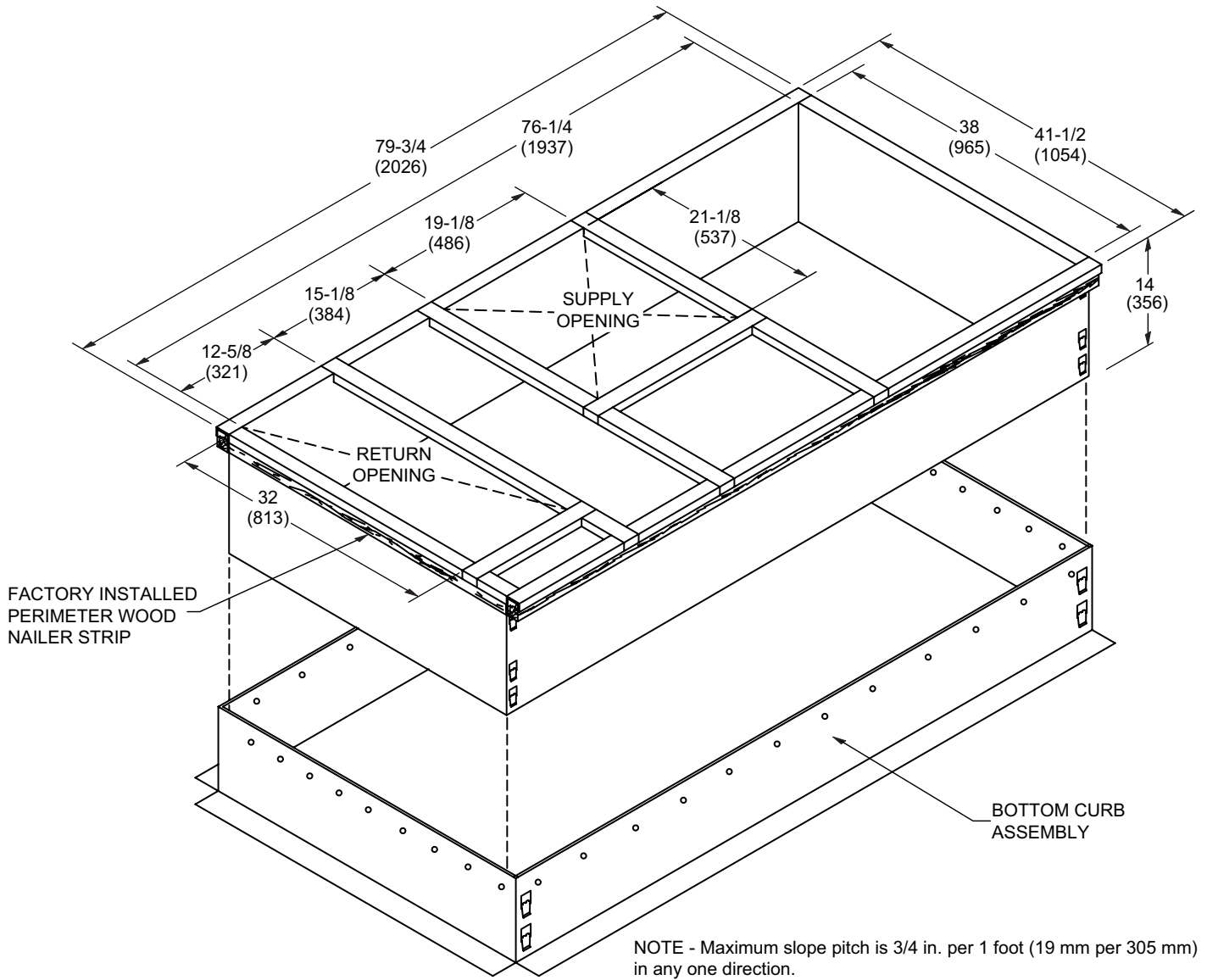

TYPICAL FLASHING DETAIL FOR ROOF CURB

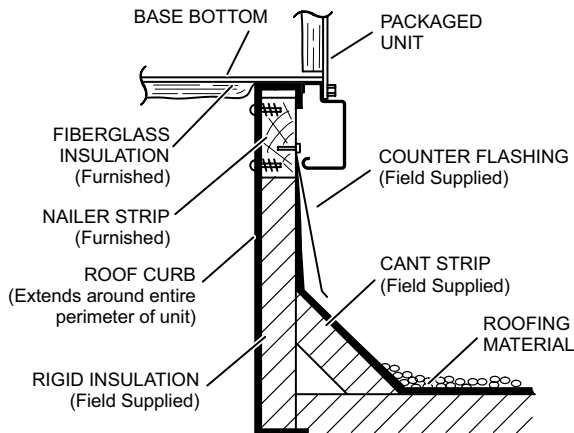

DETAIL ROOF CURB

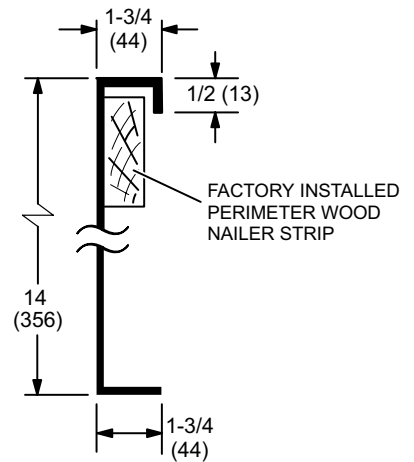

DIMENSIONS - ACCESSORIES

TRANSITIONS

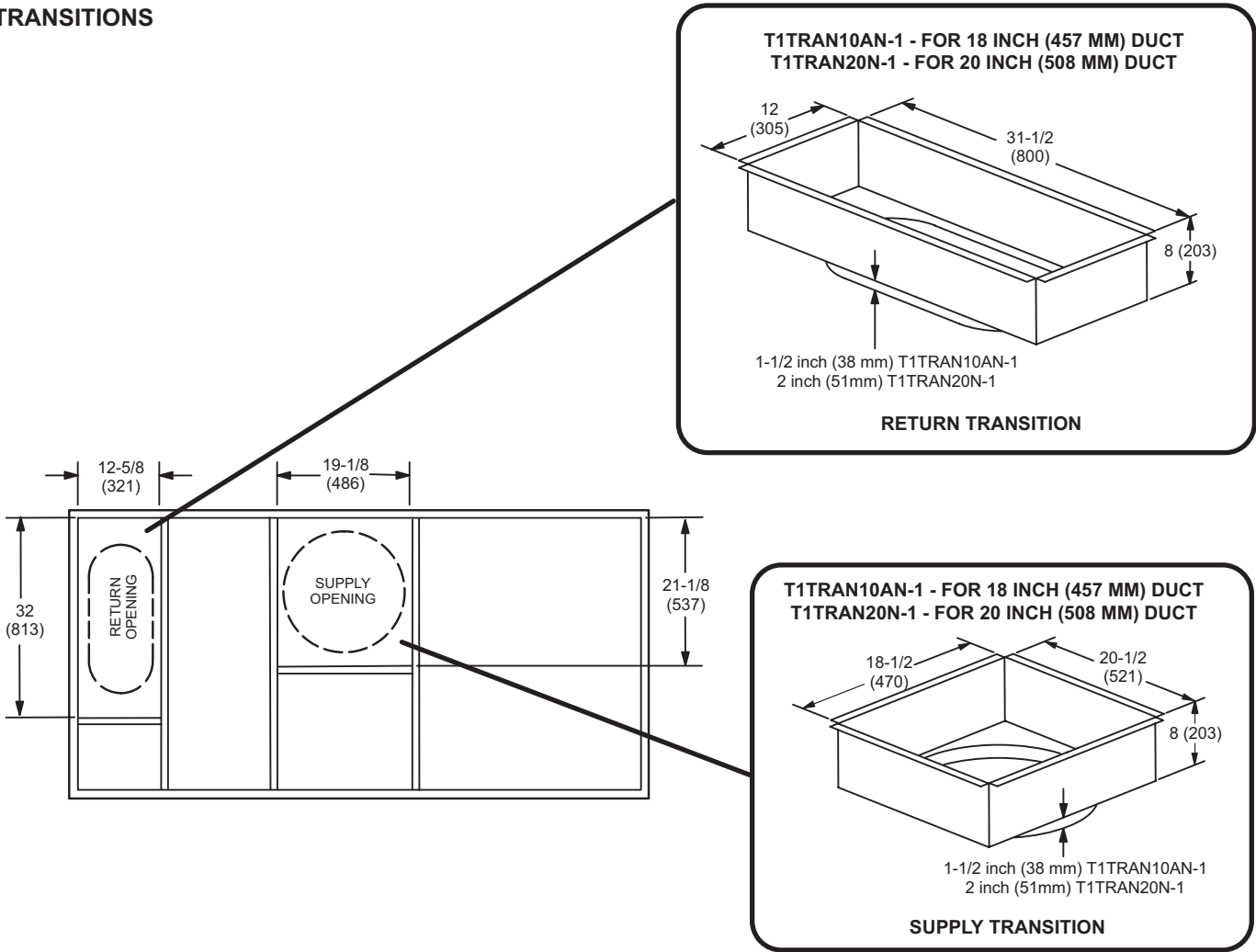

DIMENSIONS - ACCESSORIES

COMBINATION CEILING SUPPLY AND RETURN DIFFUSERS

STEP-DOWN CEILING DIFFUSER

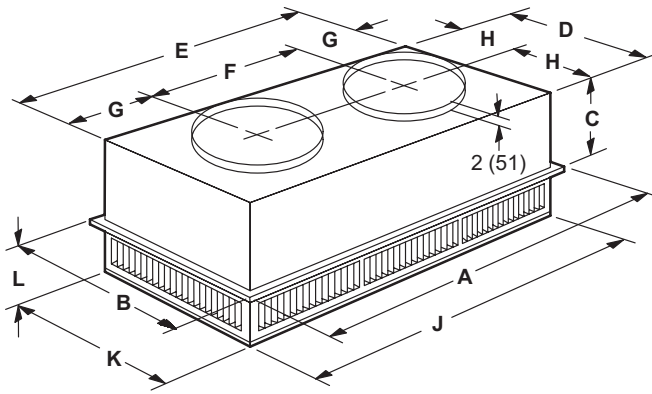

Model		RTD9-65S	RTD11-95S
A	in.	47-5/8	47-5/8
	mm	1159	1159
B	in.	23-5/8	29-5/8
	mm	600	752
C	in.	11-3/8	14-3/8
	mm	289	365
D	in.	21-1/2	27-1/2
	mm	546	699
E	in.	45-1/2	45-1/2
	mm	1156	1158
F	in.	22-1/2	22-1/2
	mm	572	572
G	in.	11-1/2	11-1/2
	mm	292	292
H	in.	10-3/4	13-3/4
	mm	273	349
J	in.	45-1/2	45-1/2
	mm	1156	1156
K	in.	21-1/2	27-1/2
	mm	546	699
L	in.	7-1/8	8-1/8
	mm	181	206
Duct Size	in.	18 round	20 round
	mm	457 round	508 round

FLUSH CEILING DIFFUSER

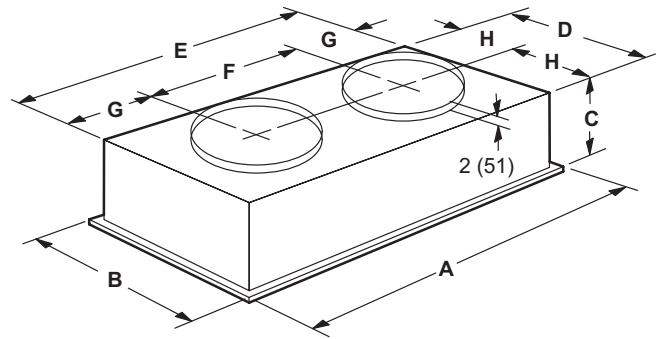

Model		FD9-65S	FD11-95S
A	in.	47-5/8	47-5/8
	mm	1159	1159
B	in.	23-5/8	29-5/8
	mm	600	752
C	in.	13-1/2	16-5/8
	mm	343	422
D	in.	21	27
	mm	533	686
E	in.	45	45
	mm	1143	1143
F	in.	22-1/2	22-1/2
	mm	572	572
G	in.	11-1/4	11-1/4
	mm	286	286
H	in.	10-1/2	13-1/2
	mm	267	343
Duct Size	in.	18 round	20 round
	mm	457 round	508 round

REVISIONS

Sections	Description of Change
Optional Conventional Temperature Control Systems	Removed Sysbus System Cable - Product discontinued.



Visit us at www.Lennox.com

For the latest technical information, www.LennoxCommercial.com

Contact us at 1-800-4-LENNOX

NOTE - Due to Lennox' ongoing commitment to quality, Specifications, Ratings and Dimensions subject to change without notice and without incurring liability. Improper installation, adjustment, alteration, service or maintenance can cause property damage or personal injury. Installation and service must be performed by a qualified installer and servicing agency.

©2025 Lennox Industries, Inc.