

538187-01

01

02

03

04

05

06

07

08

09

10

Model: LGT, LCT 036H - 072H G, J VOLT
 COOLING - ECM BLOWER WITH HIGHER SCCR
 Voltage: 460V/3~/60Hz (G), 575V/3~/60Hz (J)
 Supersedes: N/A Form No: 538187-01 Rev: 4

LOCATION	COMPONENT DESCRIPTION
AA01,02,03	A55 CONTROL BOARD, MAIN
BB07	B1 COMPRESSOR 1
GG01,CC07	B3 MOTOR, BLOWER
HH06	B4 MOTOR, OUTDOOR FAN 1
HH06	B10 MOTOR, EXHAUST FAN 1
CC05	C6 CAPACITOR, EXHAUST FAN 1
FF05	F10 FUSE, SCCR RELAY
CC05	F57 FUSE, T5 TRANSFORMER PRIMARY
BB07	HR1 HEATER, COMPRESSOR 1
BB04,05,06	K1 CONTACTOR, COMPRESSOR 1
HH04,05	K65 RELAY, EXHAUST FAN 1
BB04,06	K191 RELAY, CRANKCASE HEATER 1
FF04	L14 VALVE, SOLENOID, REHEAT COIL 1
CC04	L34 VALVE, SOLENOID, 2 STG COMPRESSOR
EE01	RT6 SENSOR, A55 DISCHARGE (IMC)
CC01	RT17 SENSOR, OUTSIDE AIR TEMP
EE02	RT46 SENSOR, SAT. SUCT TEMP., COMP 1
CC02	RT48 SENSOR, SAT. LIQUID TEMP., COMP 1
AA01	S4 LIMIT, HI PRESS. SWITCH, COMP 1
AA01	S87 SWITCH, LOW PRESS., COMP 1
DD04	T1 TRANSFORMER, CONTROL
DD05	T5 TRANSFORMER, MOTOR
EE04	T43 TRANSFORMER, REHEAT

NOTES
1 RT6 REMOTE MOUNT WIRING
2 MOVE WIRES FROM 240 TO 208 TAP ON TRANSFORMER FOR 208 VOLT APPLICATIONS
3 W/O HUMIDITROL, W/O PHASE DETECTION - T1 CONNECTED TO J/P395-1,2,3,4
4 PHASE DETECTION - T1 CONNECTED TO J/P395-1,2. T43 CONNECTED TO J/P395-3,4
5 HUMIDITROL - T1 CONNECTED TO J/P395-1,2. T43 CONNECTED TO J/P395-3,4 & J/P394-2,5. L14 CONNECTED TO J/P394-1,4
6 FOR MODULATING GAS HEAT UNIT ONLY, REFER TO RT6 AS SHOWN IN THE HEATING WIRING DIAGRAM (A-SECTION)

← DENOTES OPTIONAL COMPONENTS AND WIRING

WARNING
 DISCONNECT ALL POWER BEFORE SERVICING.
 ELECTRIC SHOCK HAZARD, CAN CAUSE INJURY OR DEATH. UNIT MUST BE GROUNDED IN ACCORDANCE WITH NATIONAL AND LOCAL CODES.
 FOR USE WITH COPPER CONDUCTORS ONLY. REFER TO UNIT RATING PLATE FOR MINIMUM CIRCUIT AMPACITY AND MAXIMUM OVERCURRENT PROTECTION SIZE.
 IF ANY WIRE IN THIS APPLIANCE IS REPLACED, IT MUST BE REPLACED WITH WIRE OF LIKE SIZE, RATING AND INSULATION THICKNESS.

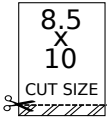
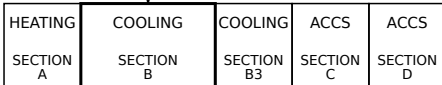

REV	EC NO.	DATE	BY	APVD	REVISION NOTE
--	CN-008852	06/01/2022	AHL	AAH	ORIGINATED AT PD&R CARROLLTON, TX
003	CN-014014F	1/6/2026	ZN	AWH	A) CLEANED UP WIRES TO GAS SECTION (A-SECT)
004	CN-013731A	3/3/2026	ZN	HMT	A) ADDED NOTE 6 FOR MODULATING GAS HEAT

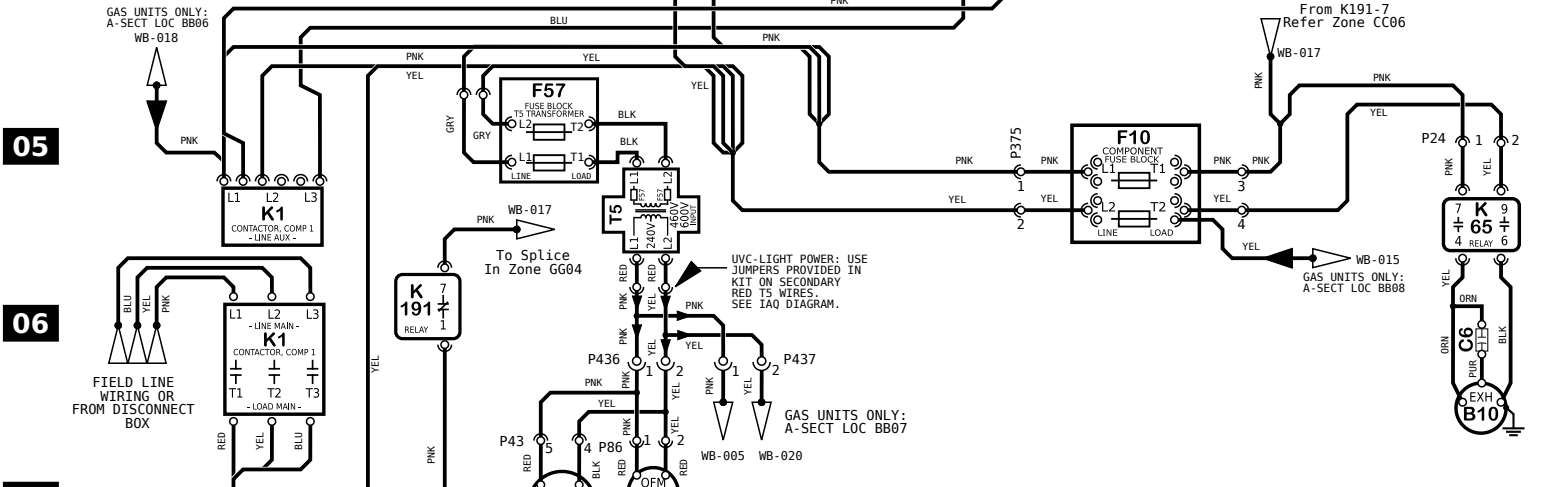
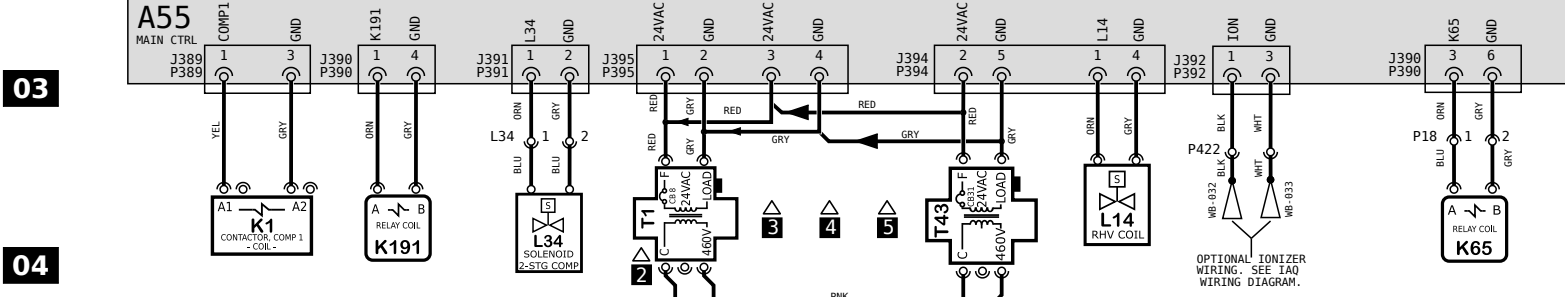
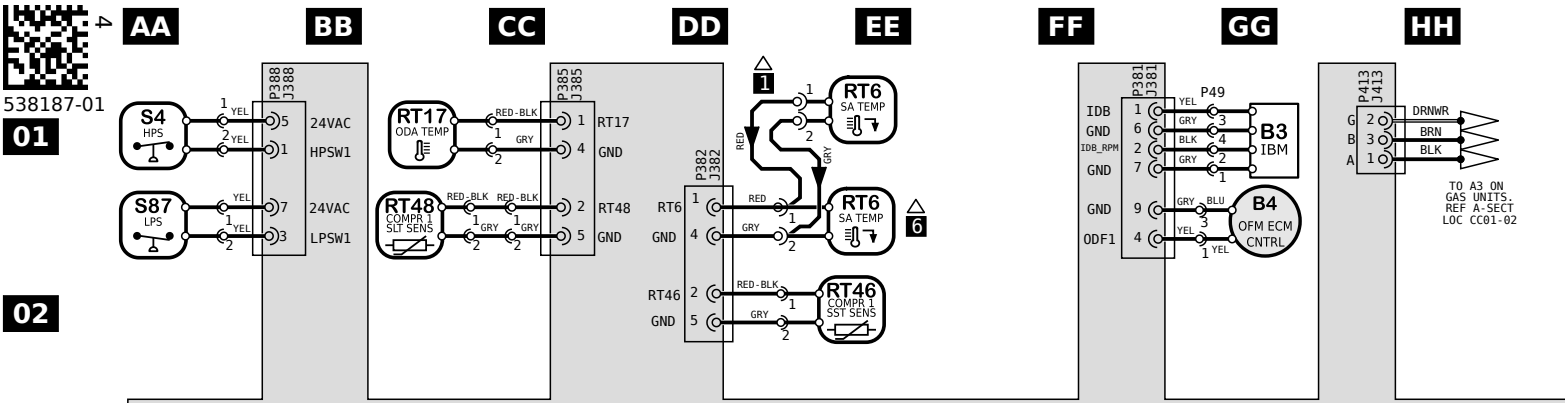

LOCATION	COMPONENT DESCRIPTION
AA01,02,03	A55 CONTROL BOARD, MAIN
BB07	B1 COMPRESSOR 1
GG01,CC07	B3 MOTOR, BLOWER
HH06	B4 MOTOR, OUTDOOR FAN 1
HH06	B10 MOTOR, EXHAUST FAN 1
GG02,DD07	B4 MOTOR, OUTDOOR FAN 1
HH06	C6 CAPACITOR, EXHAUST FAN 1
FF05	F10 FUSE, SCCR RELAY
CC05	F57 FUSE, T5 TRANSFORMER PRIMARY
BB07	HR1 HEATER, COMPRESSOR 1
BB04,05,06	K1 CONTACTOR, COMPRESSOR 1
HH04,05	K65 RELAY, EXHAUST FAN 1
BB04,06	K191 RELAY, CRANKCASE HEATER 1
FF04	L14 VALVE, SOLENOID, REHEAT COIL 1
CC04	L34 VALVE, SOLENOID, 2 STG COMPRESSOR
EE01	RT6 SENSOR, A55 DISCHARGE (IMC)
CC01	RT17 SENSOR, OUTSIDE AIR TEMP
EE02	RT46 SENSOR, SAT. SUCT TEMP., COMP 1
CC02	RT48 SENSOR, SAT. LIQUID TEMP., COMP 1
AA01	S4 LIMIT, HI PRESS. SWITCH, COMP 1
AA01	S87 SWITCH, LOW PRESS., COMP 1
DD04	T1 TRANSFORMER, CONTROL
DD05	T5 TRANSFORMER, MOTOR
EE04	T43 TRANSFORMER, REHEAT

NOTES

- RT6 REMOTE MOUNT WIRING
- MOVE WIRES FROM 240 TO 208 TAP ON TRANSFORMER FOR 208 VOLT APPLICATIONS
- W/O HUMIDITROL, W/O PHASE DETECTION - T1 CONNECTED TO J/P395-1,2,3,4
- PHASE DETECTION - T1 CONNECTED TO J/P395-1,2. T43 CONNECTED TO J/P395-3,4
- HUMIDITROL - T1 CONNECTED TO J/P395-1,2. T43 CONNECTED TO J/P395-3,4 & J/P394-2,5. L14 CONNECTED TO J/P394-1,4
- FOR MODULATING GAS HEAT UNIT ONLY, REFER TO RT6 AS SHOWN IN THE HEATING WIRING DIAGRAM (A-SECTION)

KEY LIST

← DENOTES OPTIONAL COMPONENTS AND WIRING

WARNING

DISCONNECT ALL POWER BEFORE SERVICING.

ELECTRIC SHOCK HAZARD, CAN CAUSE INJURY OR DEATH. UNIT MUST BE GROUNDED IN ACCORDANCE WITH NATIONAL AND LOCAL CODES.

FOR USE WITH COPPER CONDUCTORS ONLY. REFER TO UNIT RATING PLATE FOR MINIMUM CIRCUIT AMPACITY AND MAXIMUM OVERCURRENT PROTECTION SIZE.

IF ANY WIRE IN THIS APPLIANCE IS REPLACED, IT MUST BE REPLACED WITH WIRE OF LIKE SIZE, RATING AND INSULATION THICKNESS.

10 Model: LGT, LCT 036H - 072H G, J VOLT
 COOLING - ECM BLOWER WITH HIGHER SCCR
 Voltage: 460V/3~/60Hz (G), 575V/3~/60Hz (J)
 Supersedes: N/A Form No: 538187-01 Rev: 4

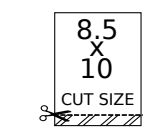
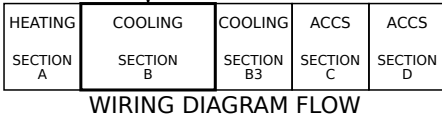

REV	EC NO.	DATE	BY	APVD	REVISION NOTE
--	CN-008852	06/01/2022	AHL	AAH	ORIGINATED AT PD&R CARROLLTON, TX
003	CN-014014F	1/6/2026	ZN	AWH	A) CLEANED UP WIRES TO GAS SECTION (A-SECT)
004	CN-013731A	3/3/2026	ZN	HMT	A) ADDED NOTE 6 FOR MODULATING GAS HEAT