

# LRP13ACK

MERIT® SERIES

Constant Torque Blower | Single-Phase | R-454B | 60Hz

RESIDENTIAL  
PRODUCT SPECIFICATIONS (EHB)



SEER2 - 13.4

2 to 5 Tons

Cooling Capacity - 22,600 to 57,400 Btuh

Optional Electric Heat - 5 to 20 kW



**MERIT®**  
SERIES



2025 COMPLIANT  
REFRIGERANT

## MODEL NUMBER IDENTIFICATION

**L RP 13 AC K 36 E P -1 -A**

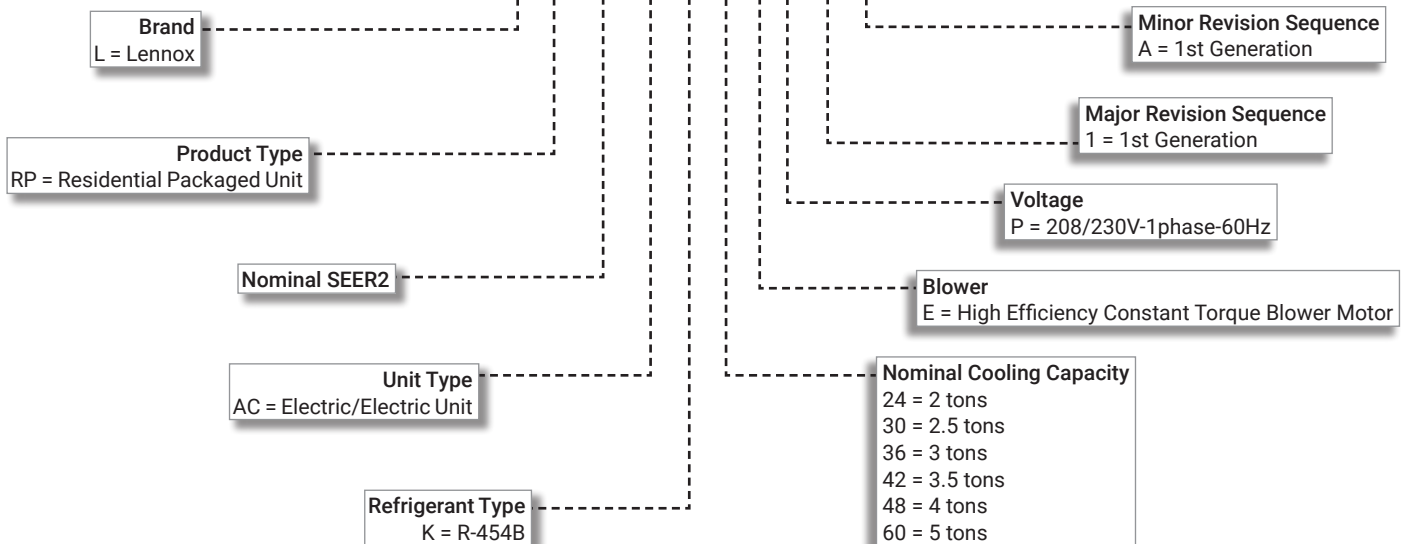

## CONTENTS

Approvals And Warranty . . . . .	2
Blower Data . . . . .	13
Control Options . . . . .	6
Cooling Ratings . . . . .	11
Dimensions . . . . .	15
- Accessories . . . . .	16
- Unit . . . . .	15
Electrical Data . . . . .	7
Electric Heat Capacities . . . . .	10
Electric Heat Data . . . . .	9
Features . . . . .	3
Field Wiring . . . . .	10
Installation Clearances . . . . .	14
Model Number Identification . . . . .	1
Optional Accessories - Order Separately . . . . .	8
Specifications . . . . .	7

## APPROVALS AND WARRANTY

### APPROVALS

- AHRI Standard 210/240-2023 Certified
- Design Certified by ETL Intertek
- Cooling system rated according to DOE test procedures
- Units are ETL Certified for the U.S. and Canada
- Unit and components are UL bonded for grounding to meet safety standards for servicing
- All models meet UL 60335-2-40 Refrigerant Detector Requirements
- All models with the Optional Seismic Strapping Kit installed have Seismic Certification for 2018 International Building Code (IBC) and 2019 California Building Code (CBC) ASCE 7
- Optional electric heaters are ETL listed for the US and Canada and are rated and tested according to DOE test procedures and FTC labeling regulations
- Test operated at the factory before shipment ensuring dependable operation at start-up

### WARRANTY

- Compressor:
  - Limited ten years in residential installations
  - Limited five years in non-residential installations
- All other covered components:
  - Limited five years in residential installations
  - Limited one year in non-residential installations

**NOTE** - Refer to Lennox® Basic Limited Warranty at [www.Lennox.com](http://www.Lennox.com) for additional details.

## FEATURES

### **APPLICATIONS**

- Designed for outdoor installations at ground level or rooftop for residential applications

### **COOLING SYSTEM**

#### **R-454B Refrigerant**

- Low GWP (Global Warming Potential)
- Zero ODP (Ozone Depletion Potential)
- Low Toxicity/Lower Flammability - A2L
- Unit is factory pre-charged

#### **Evaporator and Condenser Coils**

- Copper tube with aluminum fin coils

#### **Anti-Microbial Evaporator Coil Drain Pan**

- Anti-Microbial additive resists growth of mold and mildew on drain pan which improves indoor air quality and reduces drain line blockage
- Drain pan overflow switch monitors condensate level in drain pan and shuts down unit if drain becomes clogged
- Fully insulated to reduce condensation

#### **Condenser Fan**

- Weather protected heavy duty condenser fan motor
- Coated steel fan blades for long life
- Corrosion-resistant coated steel fan guard
- Internally mounted
- Totally enclosed fan motor

#### **High Pressure Switch**

- Protects the system from high pressure conditions
- Automatic reset.

#### **Loss of Charge Switch**

- Protects compressor from damage from low/no refrigerant charge conditions
- SPST, normally-closed
- Automatic reset

#### **Service Valves**

- Fully serviceable brass valves installed in discharge and liquid lines

### **LOW GWP REFRIGERANT DETECTION SYSTEM (RDS)**

- Complies with UL 60335-2-40 approved standard
- Required for all systems using R-454B refrigerant
- Factory installed on all units
- Consists of a leak detection sensor(s) and a mitigation control
- Ensures safe operation for systems equipped with R-454B refrigerant
- Sensor(s) monitors indoor coil area for any refrigerant leaks if they occur
- If a leak is detected the refrigerant detection system will prevent compressor and heating operation until a leak is no longer detected
- Refrigeration detection system energizes blower while a leak is detected to mitigate any concentrations of refrigerant from the unit and the system

### **COMPRESSOR**

- Rotary Compressor furnished on 24 and 30 models
- Scroll Compressor furnished on 36 through 60 models
- High volumetric efficiency
- Uniform suction flow
- Constant discharge flow
- Quiet operation
- Low gas pulses during compression reduces operational sound levels
- Compressor motor is internally protected from excessive current and temperature
- Compressor is installed in the unit on resilient rubber mounts for vibration free operation

### **Optional Accessories**

#### **Compressor Crankcase Heater (36 through 60 models)**

- Protects against refrigerant migration that can occur during low ambient operation

#### **Compressor Hard Start Kit**

- Single-phase units are equipped with a PSC compressor motor. This type of motor normally doesn't need a potential relay and start capacitor
- In conditions such as low voltage, this kit may be required to increase the compressor starting torque

#### **Compressor Timed-Off Control**

- Prevents compressor short-cycling
- Allows time for suction and discharge pressure to equalize
- Permits compressor start-up in an unloaded condition
- Automatic reset
- Five minute delay between compressor shut-off and start-up

#### **Low Ambient Kit (40°F)**

- Cycles the outdoor fan while allowing compressor operation in the cooling cycle
- This intermittent fan operation allows the system to operate without icing the evaporator coil and losing capacity
- Designed for use in ambient temperatures no lower than 40°F

**NOTE** - A crankcase heater must be installed on the compressor.

## FEATURES

### **CABINET**

- Conditioned areas insulated with foil faced insulation
- Minimizes heat loss and reduce operating sound levels
- Powder paint for maximum durability
- Easy service access
- Steel louvered panels provides complete coil protection
- Full perimeter heavy-gauge galvanized steel base rail
- Base rails have rigging holes
- Two sides of the base rail have forklift slots
- Raised edges around duct and power entry openings in the bottom of the unit for water protection

### **Airflow Choice**

- Units are shipped with all air openings sealed
  - For downflow (vertical) applications, remove the downflow duct covers
  - For horizontal applications, remove the horizontal duct covers

### **Electrical Inlets and Service Valves**

- Standard field wiring electrical inlets are located in one central area of the cabinet
- See dimension drawing
- Gauge ports are located inside the cabinet

### **Optional Accessories**

#### **Base Rail Opening Closure Kit**

- Kit consists of panels and hardware to cover base rail rigging holes and forklift slot openings

#### **Bottom Power Entry Kit**

- Allows field wiring through the unit base pan

#### **Rectangular to Round Duct Adaptor Kits**

- Downflow or horizontal kits available
- Converts rectangular supply and return air openings on unit cabinet to round diameter
- Several sizes available

#### **Clip Curb (Full Perimeter)**

- Interlocking tabs fasten corners together
- No tools required
- Fully gasketed around curb perimeter and supply and return openings
- Available in 8, 14, 18 and 24 inch heights
- Shipped knocked down

#### **Adjustable Pitch Roof Curb (Full Perimeter)**

- Fully adjustable pitch curb provides a level platform for packaged units
- Allows flexible installations on roofs with sloped or uneven angles
- Adjustable from 2/12 to 6/12 pitch
- Fully gasketed around curb perimeter and supply and return openings
- Clip Curb (knock-down) and Welded models available

#### **All Curbs**

- IBC 2018 compliant
- CBC 2019 compliant
- Seismic rating - SDS 2.0g, z/h=1, Ip=1.5
- Wind rating - 240 mph (Lateral), 214 mph (Uplift)
- Maximum load rating - 800 lbs.

#### **Adaptor Curbs (not shown)**

- Curbs are regionally sourced
- Dimensions vary based upon the source

**NOTE** - Contact your local sales representative for a detailed cut sheet with applicable dimensions.

#### **Strapping Kit - Seismic**

- Heavy-gauge galvanized steel
- Kit contains 4 brackets and mounting hardware

## FEATURES

### **AIR FILTER (required)**

#### Optional Accessories

#### Internal Filter Rack Kits

- Available for 1 in. thick filters
- Filter rails mount internal to unit

**NOTE** - Filters must be field provided.

### **SUPPLY AIR BLOWER**

- Direct drive blower
- Blower wheel is statically and dynamically balanced
- Resiliently mounted
- Blower assembly easily removed for servicing

#### Constant Torque Blower Motor

- DC Brushless Motor
- High Efficiency Constant Torque
- ECM (Electronically Commutated Motor)
- Motor is programmed to provide constant torque at each of the selectable speeds
- Fixed blower "On" delay prevents cold air from entering system during gas heating demand
- See Blower Performance tables

### **ELECTRIC HEAT (5-20 KW)**

#### Optional Accessories

- Field installed internal to unit cabinet
- Available in several voltages and kW sizes
- Helix wound nichrome heating elements exposed directly in air stream
- Instant heat transfer
- Low element temperatures and long service life
- Cutoff limit control provides positive protection in case of excessive temperatures
- Factory assembled with controls installed and wired

#### Single Point Power Supply Kits

- Control Box used with optional electric heat
- For single power supply connected to multi-circuit electric heat

**NOTE** - Side power entry only.

### **CONTROLS**

#### Refrigerant Detection System (RDS) Control

- Monitors leak detection sensor
- Connections for external RDS alarm system (not furnished)
- LED for power, monitoring and sensor status
- Test/Reset button for troubleshooting

#### 24 Volt Transformer

- 40VA transformer furnished and factory installed in control area

#### Optional Accessories

#### Thermostat

- Thermostat is not furnished with unit
- See Page 6

## CONTROL OPTIONS

### E40 Smart Wi-Fi Thermostat

- 3 Htg.-2 Clg.
- 7-day, universal, programmable, touchscreen thermostat
- Controls dehumidification during cooling mode and humidification during heating mode
- Smooth Setback Recovery and compressor short-cycle protection
- One-Touch Away Mode, Smart Away™ (geo-fencing), equipment maintenance reminders and scheduling
- Smart home automation compatible with Amazon Alexa®, Google Assistant, Control4®, Building36® and Matter
- Lennox® Home App controls temperature, fan operation, set programs/schedules and set Away mode on a smartphone
- Lennox Smart Tech App allows the installer to commission the system and remotely turn the system on and off during setup or service call on a smartphone



### M40 Smart Wi-Fi Thermostat

- 3 Htg.-2 Clg.
- 7-day, universal, programmable, touchscreen thermostat
- Smooth Setback Recovery and compressor short-cycle protection
- One-Touch Away Mode, Smart Away™ (geo-fencing), equipment maintenance reminders and scheduling
- Smart home automation compatible with Apple HomeKit™, Amazon Alexa®, Google Assistant and Matter
- Lennox® Home App controls temperature, fan operation, set programs/schedules and set Away mode on a smartphone
- Lennox Smart Tech App allows the installer to commission the system and remotely turn the system on and off during setup or service call on a smartphone



### L40 Smart Wi-Fi Thermostat

- 2 Htg.-1 Clg.
- 7-day, universal, programmable, touchscreen thermostat
- Provides temperature control for gas, electric and heat pumps for single-stage heating or cooling systems (including dual-fuel operation)
- One-Touch Away Mode, Smart Away™ (geo-fencing), equipment maintenance reminders and scheduling
- Smooth Setback Recovery and compressor short-cycle protection
- Smart home automation compatible with Amazon Alexa®, Google Assistant, Control4®, Building36® and Matter
- Lennox® Home App controls temperature, fan operation, set programs/schedules and set Away mode on a smartphone
- Lennox Smart Tech App allows the installer to commission the system and remotely turn the system on and off during setup or service call on a smartphone



**NOTE** - Please refer to the individual Product Specifications for these products for full information.

**NOTE** - Two-stage heating for Dual-Fuel Heat Pump applications only

## CONTROLS - ORDERING

E40 Smart Wi-Fi Thermostat	3-3/8 x 5-3/8 x 1	<b>30L26</b>
Lennox® Smart Room Sensor	4 x 5-1/2 x 3	<b>22V25</b>
Lennox® Smart Air Quality Monitor	3-5/8 x 4-3/8 x 1-3/8	<b>21P02</b>
Lennox® Wireless Extender	4 x 5-1/2 x 2-1/2	<b>22V26</b>
L40 Smart Wi-Fi Thermostat	2-13/16 x 2-13/16 x 1/4	<b>27V51</b>
M40 Smart Wi-Fi Thermostat	3-5/16 x 4-5/16 x 7/8	<b>30L27</b>
<b>Thermostat Accessories</b>		
<sup>1</sup> Discharge Air Temperature Sensor (For E40)		<b>88K38</b>
<sup>2</sup> Remote Outdoor Air Temperature Sensor (For dual-fuel and Humiditrol®)		<b>X2658</b>

<sup>1</sup> Optional for service diagnostics (E40).

<sup>2</sup> Remote Outdoor Air Temperature Sensor is used with conventional (non-Lennox® Communicating) outdoor units (sensor is furnished with Lennox® Communicating outdoor units). Allows the thermostat to display outdoor temperature. Required in dual-fuel and Humiditrol® applications.

## SPECIFICATIONS

Size		24	30	36	42	48	60
<b>Nominal Tonnage</b>		2	2.5	3	3.5	4	5
<b>Cooling Performance</b>	Total cooling capacity - Btuh	22,600	28,400	33,400	40,000	44,500	57,500
	<sup>1</sup> SEER2 (Btuh/Watt)	13.4	13.4	13.4	13.4	13.4	13.4
	<sup>1</sup> EER2 (Btuh/Watt)	10.6	10.6	10.6	10.6	10.6	10.6
<b><sup>2</sup> Sound Rating Number</b>	dBA	77	79	78	78	77	78
<b>Refrigerant</b>	Type	R-454B	R-454B	R-454B	R-454B	R-454B	R-454B
	Charge	4 lbs. 6 oz.	4 lbs. 9 oz.	4 lbs. 8 oz.	5 lbs. 6 oz.	5 lbs. 5 oz.	7 lbs. 13 oz.
<b>Compressor Type (number)</b>		Rotary (1)	Rotary (1)	Scroll (1)	Scroll (1)	Scroll (1)	Scroll (1)
<b>Outdoor Coil</b>	Net face area - ft. <sup>2</sup>	14.6	16.4	16.4	19.5	19.5	16.6
	Tube diameter - in.	5/16	5/16	5/16	5/16	5/16	5/16
	Rows	1	1	1	1	1	2
	Fins - in.	26	26	26	26	26	22
<b>Outdoor Fan</b>	HP	1/6	1/6	1/6	1/4	1/4	1/4
	Diameter - in.	22	22	22	24	24	24
	Blades	4	4	4	3	3	3
<b>Indoor Coil</b>	Net face area - ft. <sup>2</sup>	4.4	4.4	4.4	6.8	6.8	6.8
	Tube diameter - in.	3/8	5/16	5/16	5/16	5/16	3/8
	Rows	2	3	3	3	3	3
	Fins - in.	16	16	15	15	15	15
	Condensate drain size (NPT) - in.	3/4	3/4	3/4	3/4	3/4	3/4
<b>Indoor Blower</b>	HP	1/3	1/2	1/2	3/4	3/4	1
	Wheel (Number) diameter x width - in.	(1) 10 x 6	(1) 10 x 6	(1) 10 x 8	(1) 10 x 10	(1) 10 x 10	(1) 12 x 9
<b>Net weight of basic unit - lbs.</b>		367	379	387	460	461	503
<b>Shipping weight of basic unit - lbs.</b>		372	384	392	465	466	508

## ELECTRICAL DATA

Line voltage data (Volts-Phase-Hz)	208/230V-1-60						
<sup>3</sup> Maximum overcurrent protection (MOCP) amps	20	25	35	40	45	60	
<sup>4</sup> Minimum Circuit Ampacity (MCA)	14.8	17.5	22.9	26.5	28.7	39.7	
<b>Compressor</b>	Rated load amps	8.8	11.1	14.3	16.7	18.0	24.3
<b>Outdoor Coil Fan Motor</b>	Full load amps	1.0	1.0	1.0	1.7	1.7	1.7
<b>Indoor Blower Motor</b>	Full load amps	2.8	2.6	4.1	3.9	4.5	7.6

NOTE-Extremes of operating range are plus and minus 10% of line voltage.

<sup>1</sup> AHRI Certified to AHRI Standard 210/240; 95°F outdoor air temperature, 80°F db/67°F wb entering evaporator air.

<sup>2</sup> Sound Rating Number rated in accordance with test conditions included in AHRI Standard 270.

<sup>3</sup> HACR type circuit breaker or fuse.

<sup>4</sup> Refer to National or Canadian Electrical Code manual to determine wire, fuse and disconnect size requirements.

**OPTIONAL ACCESSORIES - ORDER SEPARATELY**

Item	Order Number	Size					
		24	30	36	42	48	60
<b>COOLING SYSTEM</b>							
Compressor Crankcase Heater	27U17			•	•		
	27P79					•	•
Compressor Hard Start Kit	10J42	•	•	•			
	88M91				•	•	•
Compressor Timed-Off Control	47J28	•	•	•	•	•	•
Low Ambient Kit (40°F)	21D20	•	•	•	•	•	•
<b>CABINET</b>							
Base Rail Opening Closure Kit	21J84	•	•	•	•	•	•
Rectangular to Round Duct Adaptor Kits	Downflow - 14 in. dia.	20X82	•	•	•		
	- 14 in. dia.	21D26				•	•
Horizontal - 14 in. dia.		21J92	•	•	•		
	- 14 in. dia.	21D24				•	•
- 16 in. dia.	22U78				•	•	•
- 18 in. dia.	22U79				•	•	•
<b>ELECTRICAL</b>							
Bottom Power Entry Kit	21J78	•	•	•	•	•	•
<b>ELECTRIC HEAT</b>							
208/230V-1ph	5 kW	10W47	•	•	•	•	•
	7.5 kW	10W48	•	•	•	•	•
	10 kW	10W49	•	•	•	•	•
	15 kW	10W50			•	•	•
	20 kW	10W51				•	•
<b>SINGLE POINT POWER SUPPLY KITS (FOR ELECTRIC HEAT) - SIDE POWER ENTRY ONLY</b>							
	For 5 kW Electric Heat	13W88	•	•	•	•	•
	For 7.5 kW Electric Heat	13W89	•	•	•	•	•
	For 10 kW Electric Heat	13W90	•	•	•	•	•
	For 15 and 20 kW Electric Heat	13W91			•	•	•
<b>INDOOR AIR QUALITY</b>							
<sup>1</sup> Internal Filter Rack Kit (filters not furnished)	(1) 20 x 20 + (1) 14 x 20	11U73	•	•	•		
	(2) 20 x 20	11U74				•	•
<b>ROOF CURBS</b>							
<b>Clip Curbs</b>							
8 in height		21J13	•	•	•		
		21J17				•	•
14 in height		21J14	•	•	•		
		21J19				•	•
18 in height		21J15	•	•	•		
		21J20				•	•
24 in height		21J16	•	•	•		
		21J25				•	•
<b>Adjustable Pitch Roof Curbs</b>							
Welded Curbs		22V54	•	•	•		
		22V55				•	•
Clip Curbs		21J26	•	•	•		
		21U04				•	•
<b>Strapping Kits for Roof Curbs</b>							
Strapping Kit - Seismic	21J75	•	•	•	•	•	•

<sup>1</sup> Filters are not furnished and must be field provided.

## ELECTRIC HEAT DATA

Model			LRP13ACK24		LRP13ACK30		LRP13ACK36	
Voltage			208V	240V	208V	240V	208V	240V
<sup>1</sup> Maximum Overcurrent Protection (MOCP)	5 kW	Circuit 1	30	30	30	30	30	35
	7.5 kW	Circuit 1	40	45	40	45	40	45
	10 kW	Circuit 1	50	60	50	60	60	60
	15 kW	Circuit 1	---	---	---	---	60	60
		Circuit 2	---	---	---	---	25	30
<sup>2</sup> Minimum Circuit Ampacity (MCA)	5 kW	Circuit 1	26.1	29.5	25.8	29.3	26.6	30.0
	7.5 kW	Circuit 1	37.4	42.6	37.1	42.3	39.0	44.2
	10 kW	Circuit 1	48.6	55.6	48.4	55.3	50.3	57.2
	15 kW	Circuit 1	---	---	---	---	50.3	57.2
		Circuit 2	---	---	---	---	22.6	26
<sup>1</sup> Maximum Overcurrent Protection (MOCP) with Optional Single Point Power Supply	5 kW		30	30	30	30	30	35
	7.5 kW		40	45	40	45	40	45
	10 kW		50	60	50	60	60	60
	15 kW		---	---	---	---	80	90
<sup>2</sup> Minimum Circuit Ampacity (MCA) with Optional Single Point Power Supply	5 kW		26.1	29.5	25.8	29.3	22.7	31.2
	7.5 kW		37.4	42.6	37.1	42.3	39.0	44.2
	10 kW		48.6	55.6	48.4	55.3	50.3	57.2
	15 kW		---	---	---	---	72.8	83.3
Model No.			LRP13ACK42		LRP13ACK48		LRP13ACK60	
Voltage			208V	240V	208V	240V	208V	240V
<sup>1</sup> Maximum Overcurrent Protection (MOCP)	5 kW	Circuit 1	35	35	35	35	30	35
	7.5 kW	Circuit 1	40	45	40	45	45	50
		Circuit 2	---	---	---	---	---	---
	10 kW	Circuit 1	60	60	60	60	60	70
		Circuit 2	---	---	---	---	---	---
	15 kW	Circuit 1	60	60	60	60	60	70
		Circuit 2	25	30	25	30	25	30
20 kW	Circuit 1	60	60	60	60	60	70	
	Circuit 2	50	60	50	60	50	60	
<sup>2</sup> Minimum Circuit Ampacity (MCA)	5 kW	Circuit 1	30.1	33.5	30.1	33.5	27.8	31.3
	7.5 kW	Circuit 1	38.7	43.9	39.5	44.7	43.4	48.6
		Circuit 2	---	---	---	---	---	---
	10 kW	Circuit 1	50.0	57.0	50.8	57.7	54.6	61.6
		Circuit 2	---	---	---	---	---	---
	15 kW	Circuit 1	50.0	57.0	50.8	57.7	54.6	61.6
		Circuit 2	22.6	26	22.6	26	22.6	26
20 kW	Circuit 1	50.0	57.0	50.8	57.7	54.6	61.6	
	Circuit 2	45.1	52.1	45.1	52.1	45.1	52.1	
<sup>1</sup> Maximum Overcurrent Protection (MOCP) with Optional Single Point Power Supply	5 kW		30	35	30	35	60	60
	7.5 kW		40	45	40	45	50	50
	10 kW		60	60	60	60	60	70
	15 kW		80	90	80	90	80	90
	20 kW		100	110	100	110	100	125
<sup>2</sup> Minimum Circuit Ampacity (MCA) with Optional Single Point Power Supply	5 kW		27.4	30.9	28.2	31.7	39.7	39.7
	7.5 kW		38.7	43.9	39.5	44.7	43.4	48.6
	10 kW		50.0	57.0	50.8	57.7	54.6	61.6
	15 kW		72.6	83.0	73.3	83.8	77.2	87.6
	20 kW		95.2	109.0	95.9	109.8	99.8	113.7

NOTE - All units have a minimum Short Circuit Current Rating (SCCR) of 5000 amps.

NOTE - Circuit 1 Minimum Circuit Ampacity includes the Blower Motor Full Load Amps.

NOTE- Extremes of operating range are plus and minus 10% of line voltage.

<sup>1</sup> HACR type breaker or fuse.

<sup>2</sup> Refer to National or Canadian Electrical Code manual to determine wire, fuse and disconnect size requirements.

## ELECTRIC HEAT CAPACITIES

Input Voltage	5 kW			7.5 kW			10 kW			15 kW			20 kW		
	No of Steps	kW Input	KBtuh Output	No of Steps	kW Input	KBtuh Output	No of Steps	kW Input	KBtuh Output	No of Steps	kW Input	KBtuh Output	No of Steps	kW Input	KBtuh Output
208	1	3.8	12.8	1	5.6	19.2	1	7.5	25.6	1	11.2	38.2	1	15	51.2
220	1	4.2	14.3	1	6.3	21.5	1	8.4	28.7	1	12.6	43	1	16.8	57.3
230	1	4.6	15.7	1	6.9	23.5	1	9.2	31.3	1	13.8	47	1	18.4	62.7
240	1	5	17.1	1	7.5	25.6	1	10	34.1	1	15	51.2	1	20	68.2

## FIELD WIRING

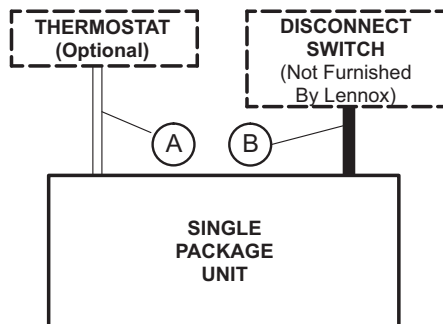

A – Five Wire Low Voltage (Electronic)

B – Two Wire Power (See Electrical Data Table)

If multiple disconnects are used on units with electric heat; there must be two-wire power provided for each disconnect

– Field Wiring Not Furnished –

# COOLING RATINGS

NOTE – For Temperatures and Capacities not shown in tables, see bulletin – Cooling Unit Rating Table Correction Factor Data in Miscellaneous Engineering Data section.

## 2 TON - LRP13ACK024

Entering Wet Bulb Temperature	Total Air Volume	Outdoor Air Temperature Entering Outdoor Coil																							
		85°F						95°F						105°F						115°F					
		Total Cool Cap.	Comp. Motor Input	Sensible To Total Ratio (S/T)			Total Cool Cap.	Comp. Motor Input	Sensible To Total Ratio (S/T)			Total Cool Cap.	Comp. Motor Input	Sensible To Total Ratio (S/T)			Total Cool Cap.	Comp. Motor Input	Sensible To Total Ratio (S/T)						
				Dry Bulb					Dry Bulb					Dry Bulb					Dry Bulb						
cfm	kBtuh	kW	75°F	80°F	85°F	kBtuh	kW	75°F	80°F	85°F	kBtuh	kW	75°F	80°F	85°F	kBtuh	kW	75°F	80°F	85°F					
59°F	650	21.4	1.35	.89	1.00	1.00	20.6	1.52	.91	1.00	1.00	19.8	1.71	.93	1.00	1.00	18.9	1.93	.96	1.00	1.00				
	830	23.2	1.35	.96	1.00	1.00	22.2	1.52	.98	1.00	1.00	21.4	1.72	1.00	1.00	1.00	20.2	1.94	1.00	1.00	1.00				
	1000	24.4	1.34	1.00	1.00	1.00	23.4	1.52	1.00	1.00	1.00	22.2	1.72	1.00	1.00	1.00	21.2	1.94	1.00	1.00	1.00				
63°F	650	22.4	1.35	.74	.86	.98	21.4	1.52	.76	.88	1.00	20.4	1.71	.77	.90	1.00	19.3	1.93	.79	.92	1.00				
	830	23.6	1.34	.79	.93	1.00	22.6	1.52	.80	.95	1.00	21.4	1.72	.82	.97	1.00	20.2	1.94	.84	1.00	1.00				
	1000	24.6	1.34	.83	.99	1.00	23.4	1.52	.85	1.00	1.00	22.4	1.72	.87	1.00	1.00	21.2	1.94	.90	1.00	1.00				
67°F	650	23.8	1.34	.60	.72	.84	22.8	1.52	.61	.73	.85	21.6	1.72	.62	.75	.87	20.4	1.94	.63	.77	.90				
	830	25.0	1.34	.63	.77	.90	24.0	1.52	.64	.78	.92	22.6	1.72	.66	.81	.95	21.4	1.95	.67	.83	.98				
	1000	26.0	1.33	.66	.81	.96	24.6	1.52	.68	.83	.98	23.2	1.72	.69	.85	1.00	22.0	1.95	.71	.88	1.00				
71°F	650	25.0	1.34	.46	.59	.70	23.8	1.52	.47	.59	.72	22.6	1.72	.47	.61	.73	21.4	1.95	.49	.62	.75				
	830	26.4	1.33	.48	.62	.75	25.2	1.52	.49	.63	.76	23.8	1.72	.49	.65	.79	22.4	1.95	.50	.67	.81				
	1000	27.4	1.32	.50	.65	.79	26.0	1.51	.51	.67	.81	24.6	1.72	.51	.68	.84	23.2	1.96	.52	.70	.86				

## 2.5 TON - LRP13ACK030

Entering Wet Bulb Temperature	Total Air Volume	Outdoor Air Temperature Entering Outdoor Coil																							
		85°F						95°F						105°F						115°F					
		Total Cool Cap.	Comp. Motor Input	Sensible To Total Ratio (S/T)			Total Cool Cap.	Comp. Motor Input	Sensible To Total Ratio (S/T)			Total Cool Cap.	Comp. Motor Input	Sensible To Total Ratio (S/T)			Total Cool Cap.	Comp. Motor Input	Sensible To Total Ratio (S/T)						
				Dry Bulb					Dry Bulb					Dry Bulb					Dry Bulb						
cfm	kBtuh	kW	75°F	80°F	85°F	kBtuh	kW	75°F	80°F	85°F	kBtuh	kW	75°F	80°F	85°F	kBtuh	kW	75°F	80°F	85°F					
59°F	800	27.4	1.65	.94	1.00	1.00	26.4	1.87	.97	1.00	1.00	25.2	2.10	.99	1.00	1.00	23.8	2.37	1.00	1.00	1.00				
	1000	29.2	1.66	1.00	1.00	1.00	28.0	1.88	1.00	1.00	1.00	27.0	2.12	1.00	1.00	1.00	25.4	2.40	1.00	1.00	1.00				
	1200	30.6	1.66	1.00	1.00	1.00	29.4	1.88	1.00	1.00	1.00	28.0	2.13	1.00	1.00	1.00	26.6	2.41	1.00	1.00	1.00				
63°F	800	28.4	1.66	.78	.91	1.00	27.2	1.87	.80	.93	1.00	25.6	2.11	.81	.96	1.00	24.2	2.37	.84	.99	1.00				
	1000	29.6	1.66	.84	.99	1.00	28.2	1.88	.86	1.00	1.00	27.0	2.12	.88	1.00	1.00	25.4	2.40	.91	1.00	1.00				
	1200	30.6	1.66	.90	1.00	1.00	29.4	1.88	.92	1.00	1.00	28.0	2.13	.95	1.00	1.00	26.6	2.41	.98	1.00	1.00				
67°F	800	30.0	1.66	.63	.76	.88	28.6	1.88	.64	.78	.91	27.2	2.13	.65	.80	.93	25.6	2.40	.67	.82	.96				
	1000	31.4	1.66	.67	.82	.96	29.8	1.89	.68	.84	.99	28.2	2.14	.69	.86	1.00	26.6	2.41	.72	.90	1.00				
	1200	32.2	1.66	.71	.88	1.00	30.6	1.89	.73	.90	1.00	29.0	2.15	.74	.93	1.00	27.4	2.43	.76	.96	1.00				
71°F	800	31.6	1.66	.49	.62	.74	30.2	1.89	.50	.63	.76	28.8	2.14	.50	.64	.78	27.2	2.42	.51	.66	.80				
	1000	33.0	1.66	.52	.66	.80	31.4	1.89	.51	.68	.82	29.8	2.15	.53	.69	.85	28.2	2.44	.54	.71	.88				
	1200	34.0	1.66	.53	.70	.86	32.4	1.89	.54	.72	.88	30.6	2.16	.55	.74	.91	28.8	2.44	.57	.77	.95				

## 3 TON - LRP13ACK036

Entering Wet Bulb Temperature	Total Air Volume	Outdoor Air Temperature Entering Outdoor Coil																							
		85°F						95°F						105°F						115°F					
		Total Cool Cap.	Comp. Motor Input	Sensible To Total Ratio (S/T)			Total Cool Cap.	Comp. Motor Input	Sensible To Total Ratio (S/T)			Total Cool Cap.	Comp. Motor Input	Sensible To Total Ratio (S/T)			Total Cool Cap.	Comp. Motor Input	Sensible To Total Ratio (S/T)						
				Dry Bulb					Dry Bulb					Dry Bulb					Dry Bulb						
cfm	kBtuh	kW	75°F	80°F	85°F	kBtuh	kW	75°F	80°F	85°F	kBtuh	kW	75°F	80°F	85°F	kBtuh	kW	75°F	80°F	85°F					
59°F	1000	32.4	2.01	.94	1.00	1.00	31.4	2.27	.96	1.00	1.00	30.0	2.57	.98	1.00	1.00	28.6	2.91	1.00	1.00	1.00				
	1200	34.2	2.01	1.00	1.00	1.00	33.0	2.28	1.00	1.00	1.00	31.8	2.58	1.00	1.00	1.00	30.2	2.92	1.00	1.00	1.00				
	1440	35.8	2.02	1.00	1.00	1.00	34.6	2.29	1.00	1.00	1.00	33.0	2.58	1.00	1.00	1.00	31.6	2.93	1.00	1.00	1.00				
63°F	1000	33.8	2.01	.78	.91	1.00	32.2	2.28	.79	.93	1.00	30.8	2.57	.81	.96	1.00	29.4	2.92	.83	.98	1.00				
	1200	34.8	2.02	.83	.97	1.00	33.6	2.28	.84	.99	1.00	32.0	2.58	.86	1.00	1.00	30.2	2.92	.89	1.00	1.00				
	1440	36.0	2.02	.88	1.00	1.00	34.6	2.29	.90	1.00	1.00	33.0	2.58	.92	1.00	1.00	31.6	2.93	.95	1.00	1.00				
67°F	1000	35.6	2.02	.63	.76	.88	34.0	2.28	.64	.78	.90	32.6	2.58	.65	.79	.93	30.8	2.92	.66	.81	.96				
	1200	36.8	2.02	.66	.80	.95	35.2	2.29	.67	.82	.97	33.6	2.59	.69	.84	.99	31.8	2.93	.70	.87	1.00				
	1440	37.8	2.02	.70	.86	1.00	36.2	2.29	.71	.88	1.00	34.4	2.59	.73	.91	1.00	32.4	2.93	.75	.94	1.00				
71°F	1000	37.4	2.02	.49	.62	.74	36.0	2.29	.49	.63	.75	34.2	2.59	.50	.64	.77	32.6	2.93	.51	.66	.79				
	1200	38.5	2.03	.51	.65	.79	37.0	2.30	.51	.66	.81	35.4	2.60	.52	.68	.83	33.4	2.94	.53	.70	.85				
	1440	39.5	2.03	.53	.69	.84	38.0	2.30	.53	.71	.86	36.2	2.60	.55	.73	.89	34.4	2.94	.57	.75	.92				

# COOLING RATINGS

NOTE – For Temperatures and Capacities not shown in tables, see bulletin – Cooling Unit Rating Table Correction Factor Data in Miscellaneous Engineering Data section.

## 3.5 TON - LRP13ACK042

Entering Wet Bulb Temperature	Total Air Volume	Outdoor Air Temperature Entering Outdoor Coil																			
		85°F					95°F					105°F					115°F				
		Total Cool Cap.	Comp. Motor Input	Sensible To Total Ratio (S/T)			Total Cool Cap.	Comp. Motor Input	Sensible To Total Ratio (S/T)			Total Cool Cap.	Comp. Motor Input	Sensible To Total Ratio (S/T)			Total Cool Cap.	Comp. Motor Input	Sensible To Total Ratio (S/T)		
				Dry Bulb					Dry Bulb					Dry Bulb					Dry Bulb		
cfm	kBtuh	kW	75°F	80°F	85°F	kBtuh	kW	75°F	80°F	85°F	kBtuh	kW	75°F	80°F	85°F	kBtuh	kW	75°F	80°F	85°F	
59°F	1200	41.0	2.49	.95	1.00	1.00	39.5	2.81	.96	1.00	1.00	37.8	3.16	.98	1.00	1.00	36.4	3.56	1.00	1.00	1.00
	1450	43.5	2.48	1.00	1.00	1.00	42.0	2.80	1.00	1.00	1.00	40.0	3.15	1.00	1.00	1.00	38.5	3.56	1.00	1.00	1.00
	1750	45.5	2.47	1.00	1.00	1.00	44.0	2.79	1.00	1.00	1.00	42.0	3.15	1.00	1.00	1.00	40.0	3.56	1.00	1.00	1.00
63°F	1200	42.5	2.49	.78	.92	1.00	40.5	2.80	.79	.94	1.00	38.5	3.16	.81	.96	1.00	36.8	3.56	.83	.98	1.00
	1450	44.0	2.48	.83	.98	1.00	42.5	2.80	.84	.99	1.00	40.0	3.15	.87	1.00	1.00	38.5	3.56	.89	1.00	1.00
	1750	46.0	2.47	.89	1.00	1.00	44.0	2.79	.91	1.00	1.00	42.0	3.15	.93	1.00	1.00	40.5	3.56	.96	1.00	1.00
67°F	1200	44.5	2.47	.63	.76	.89	43.0	2.79	.64	.78	.91	41.0	3.15	.65	.79	.93	39.0	3.56	.65	.81	.96
	1450	46.5	2.46	.66	.81	.95	44.5	2.79	.68	.83	.97	42.5	3.15	.68	.85	.99	40.0	3.56	.71	.87	1.00
	1750	48.0	2.45	.70	.87	1.00	45.5	2.78	.72	.89	1.00	43.5	3.14	.72	.92	1.00	41.5	3.56	.74	.94	1.00
71°F	1200	47.0	2.46	.48	.62	.74	45.0	2.78	.49	.63	.76	43.5	3.14	.50	.64	.77	41.0	3.56	.51	.66	.79
	1450	49.0	2.44	.50	.65	.80	47.0	2.77	.51	.67	.82	44.5	3.14	.52	.68	.83	42.5	3.56	.53	.69	.86
	1750	50.5	2.43	.53	.70	.86	48.0	2.76	.53	.71	.88	46.0	3.13	.55	.73	.90	43.5	3.55	.56	.75	.94

## 4 TON - LRP13ACK048

Entering Wet Bulb Temperature	Total Air Volume	Outdoor Air Temperature Entering Outdoor Coil																			
		85°F					95°F					105°F					115°F				
		Total Cool Cap.	Comp. Motor Input	Sensible To Total Ratio (S/T)			Total Cool Cap.	Comp. Motor Input	Sensible To Total Ratio (S/T)			Total Cool Cap.	Comp. Motor Input	Sensible To Total Ratio (S/T)			Total Cool Cap.	Comp. Motor Input	Sensible To Total Ratio (S/T)		
				Dry Bulb					Dry Bulb					Dry Bulb					Dry Bulb		
cfm	kBtuh	kW	75°F	80°F	85°F	kBtuh	kW	75°F	80°F	85°F	kBtuh	kW	75°F	80°F	85°F	kBtuh	kW	75°F	80°F	85°F	
59°F	1300	43.5	2.59	.94	1.00	1.00	42.0	2.96	.96	1.00	1.00	40.5	3.37	.98	1.00	1.00	38.5	3.84	1.00	1.00	1.00
	1600	46.0	2.60	1.00	1.00	1.00	44.5	2.97	1.00	1.00	1.00	42.5	3.39	1.00	1.00	1.00	40.5	3.85	1.00	1.00	1.00
	1900	48.0	2.62	1.00	1.00	1.00	46.5	2.99	1.00	1.00	1.00	44.5	3.40	1.00	1.00	1.00	42.5	3.86	1.00	1.00	1.00
63°F	1300	45.0	2.60	.77	.91	1.00	43.5	2.97	.79	.92	1.00	41.0	3.38	.80	.95	1.00	39.0	3.85	.83	.98	1.00
	1600	47.0	2.61	.83	.98	1.00	45.0	2.98	.84	1.00	1.00	43.0	3.39	.86	1.00	1.00	41.0	3.86	.89	1.00	1.00
	1900	48.0	2.62	.88	1.00	1.00	46.5	2.99	.90	1.00	1.00	45.0	3.40	.92	1.00	1.00	42.5	3.86	.95	1.00	1.00
67°F	1300	47.5	2.61	.63	.75	.88	45.5	2.98	.63	.77	.90	43.5	3.39	.64	.79	.92	41.0	3.86	.66	.81	.95
	1600	49.5	2.62	.66	.81	.95	47.5	2.99	.67	.83	.97	45.0	3.40	.69	.85	1.00	43.0	3.86	.70	.87	1.00
	1900	51.0	2.63	.70	.86	1.00	49.0	3.00	.71	.88	1.00	46.5	3.40	.72	.91	1.00	44.0	3.87	.75	.93	1.00
71°F	1300	50.0	2.62	.48	.61	.73	48.0	2.99	.49	.62	.75	46.0	3.40	.49	.63	.77	43.5	3.86	.50	.65	.79
	1600	52.0	2.63	.51	.65	.79	50.0	3.00	.51	.66	.81	47.5	3.41	.52	.68	.83	45.0	3.87	.53	.70	.86
	1900	53.5	2.63	.53	.69	.85	51.0	3.00	.54	.70	.87	48.5	3.41	.54	.72	.89	46.0	3.87	.56	.74	.92

## 5 TON - LRP13ACK060

Entering Wet Bulb Temperature	Total Air Volume	Outdoor Air Temperature Entering Outdoor Coil																			
		85°F					95°F					105°F					115°F				
		Total Cool Cap.	Comp. Motor Input	Sensible To Total Ratio (S/T)			Total Cool Cap.	Comp. Motor Input	Sensible To Total Ratio (S/T)			Total Cool Cap.	Comp. Motor Input	Sensible To Total Ratio (S/T)			Total Cool Cap.	Comp. Motor Input	Sensible To Total Ratio (S/T)		
				Dry Bulb					Dry Bulb					Dry Bulb					Dry Bulb		
cfm	kBtuh	kW	75°F	80°F	85°F	kBtuh	kW	75°F	80°F	85°F	kBtuh	kW	75°F	80°F	85°F	kBtuh	kW	75°F	80°F	85°F	
59°F	1450	55.5	3.47	.89	1.00	1.00	54.0	3.92	.91	1.00	1.00	51.5	4.43	.93	1.00	1.00	49.5	5.02	.95	1.00	1.00
	1800	60.0	3.49	.96	1.00	1.00	57.5	3.95	.98	1.00	1.00	55.0	4.46	1.00	1.00	1.00	53.0	5.06	1.00	1.00	1.00
	2100	62.5	3.50	1.00	1.00	1.00	60.0	3.96	1.00	1.00	1.00	58.0	4.48	1.00	1.00	1.00	55.0	5.08	1.00	1.00	1.00
63°F	1450	58.5	3.49	.74	.86	.98	56.5	3.94	.76	.88	1.00	54.0	4.44	.77	.90	1.00	51.0	5.03	.79	.93	1.00
	1800	61.5	3.50	.79	.93	1.00	58.5	3.95	.81	.95	1.00	56.0	4.47	.82	.98	1.00	53.5	5.06	.85	1.00	1.00
	2100	63.5	3.51	.83	.98	1.00	60.5	3.96	.85	1.00	1.00	57.5	4.48	.87	1.00	1.00	55.5	5.08	.90	1.00	1.00
67°F	1450	61.5	3.50	.60	.72	.83	59.5	3.96	.61	.73	.85	56.5	4.47	.62	.75	.87	53.5	5.06	.63	.77	.89
	1800	65.0	3.51	.64	.77	.90	61.5	3.97	.65	.79	.92	59.5	4.49	.66	.81	.95	56.0	5.09	.67	.83	.98
	2100	66.5	3.52	.67	.81	.96	64.0	3.98	.68	.83	.99	60.5	4.50	.69	.86	1.00	57.5	5.10	.71	.88	1.00
71°F	1450	65.0	3.51	.47	.59	.70	62.5	3.97	.48	.60	.71	59.5	4.49	.48	.61	.73	56.5	5.09	.49	.62	.75
	1800	67.5	3.52	.49	.63	.75	65.5	3.99	.50	.64	.77	62.0	4.51	.50	.65	.79	59.0	5.12	.52	.67	.81
	2100	69.5	3.53	.51	.66	.80	67.0	4.00	.52	.67	.82	63.5	4.52	.53	.69	.84	60.5	5.13	.54	.71	.86

## BLOWER DATA

Model	Blower Tap	Air Volume (cfm) at Various External Static Pressures - in. w.g.									
		0.1	0.2	0.3	0.4	0.5	0.6	0.7	0.8	0.9	1.0
LRP13ACK24	Tap 1 (Fan Only)	610	560	525	485	430	---	---	---	---	---
	Tap 2 (Low Cooling)	820	795	760	720	690	650	615	575	540	470
	Tap 3 (High Cooling)	960	925	885	850	815	780	745	710	675	635
LRP13ACK30	Tap 1 (Fan Only)	850	820	780	745	710	680	630	590	550	515
	Tap 2 (Low Cooling)	1040	1000	970	935	900	875	845	815	770	735
	Tap 3 (High Cooling)	1140	1105	1075	1045	1015	1000	965	925	890	825
LRP13ACK36	Tap 1 (Fan Only)	850	800	750	700	645	600	550	480	435	---
	Tap 2 (Low Cooling)	1245	1210	1175	1140	1100	1065	1025	975	920	845
	Tap 3 (High Cooling)	1390	1355	1320	1285	1250	1205	1165	1125	1050	875
LRP13ACK42	Tap 1 (Fan Only)	800	720	640	550	475	390	310	---	---	---
	Tap 2 (Low Cooling)	1470	1410	1360	1300	1260	1210	1155	1095	1000	940
	Tap 3 (High Cooling)	1600	1555	1510	1470	1430	1390	1340	1265	1210	1155
LRP13ACK48	Tap 1 (Fan Only)	1145	1075	1000	930	850	790	740	670	570	490
	Tap 2 (Low Cooling)	1675	1630	1600	1540	1490	1440	1390	1300	1230	1125
	Tap 3 (High Cooling)	1775	1735	1700	1660	1605	1555	1515	1455	---	---
LRP13ACK60	Tap 1 (Fan Only)	1045	970	895	820	745	665	580	480	---	---
	Tap 2 (Low Cooling)	1855	1810	1770	1725	1680	1630	1595	1550	---	---
	Tap 3 (High Cooling)	1965	1920	1875	1835	1785	1750	1710	1665	1615	1570

NOTE - All air data is measured external to unit with dry coil and without air filters.

## BLOWER DATA

### ACCESSORY AIR RESISTANCE DATA - in. w.g.

Air Volume cfm	Rectangular to Round Duct Adaptor Kits					
	Downflow		Horizontal			
	14 in. Diameter		14 in. Diameter		16 in. Diameter	18 in. Diameter
	24, 30, 36	42, 48, 60	24, 30, 36	42, 48, 60	42, 48, 60	42, 48, 60
500	0.03	---	0.04	---	---	---
600	0.05	---	0.07	---	---	---
700	0.08	0.13	0.08	0.13	---	---
800	0.10	0.17	0.12	0.16	---	---
900	0.12	0.21	0.15	0.21	---	---
1000	0.17	0.24	0.19	0.25	0.11	0.03
1100	0.18	0.30	0.23	0.30	0.11	0.03
1200	0.20	0.36	0.29	0.37	0.13	0.03
1300	0.26	0.43	0.31	0.43	0.17	0.03
1400	0.31	0.50	0.39	0.51	0.20	0.03
1500	---	0.57	---	0.57	0.21	0.05
1600	---	0.63	---	0.65	0.26	0.05
1700	---	0.71	---	0.72	0.30	0.06
1800	---	0.80	---	0.81	0.30	0.06
1900	---	0.91	---	0.90	0.40	0.06
2000	---	0.99	---	1.01	0.41	0.06

### INSTALLATION CLEARANCES

	in.	mm
Front (heat exchanger access)	24	610
Right Side (blower access)	24	610
Left Side (evaporator coil access)	24	610
Back	0	0
Top	48	1219

**DIMENSIONS**

**UNIT**

Size	CORNER WEIGHTS								CENTER OF GRAVITY			
	AA		BB		CC		DD		EE		FF	
	lbs.	kg	lbs.	kg	lbs.	kg	lbs.	kg	in.	mm	in.	mm
24	86	39	96	44	105	48	94	43	21	533	21-1/2	546
30	89	40	99	45	108	49	97	44	21	533	21-1/2	546
36	91	41	101	46	110	50	99	45	21	533	21-1/2	546
42	108	49	119	54	129	59	118	54	25-1/4	641	21-1/2	546
48	109	49	120	54	130	59	119	54	25-1/4	641	21-1/2	546
60	118	54	129	59	140	64	129	59	25-1/4	641	21-1/2	546

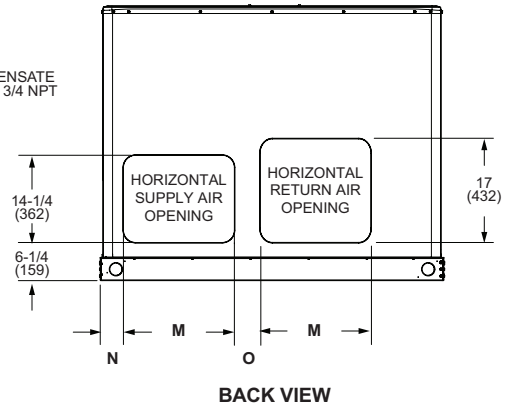
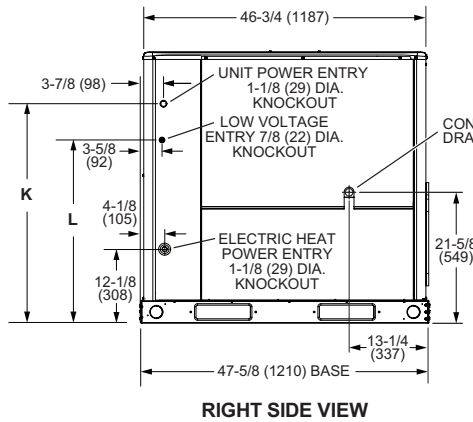
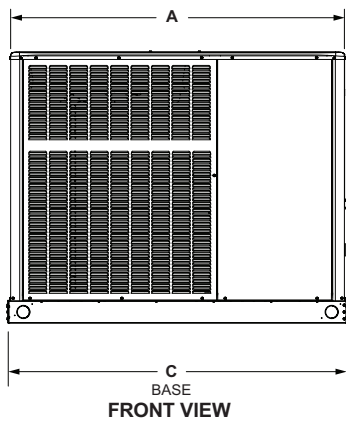
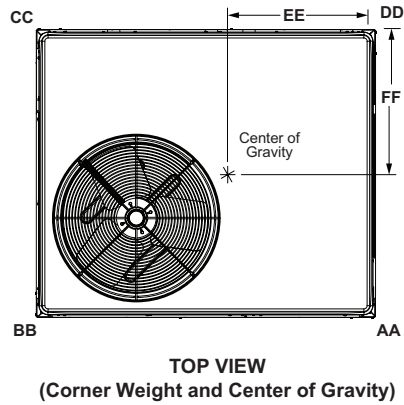
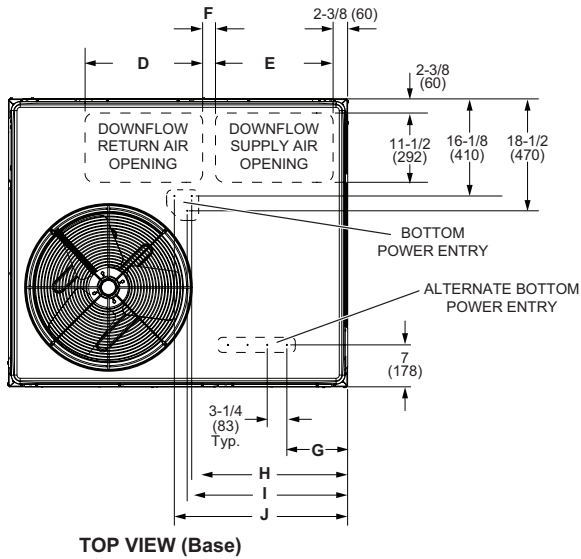

Size	A		B		C		D		E		F		G		H	
	in.	mm	in.	mm	in.	mm	in.	mm	in.	mm	in.	mm	in.	mm	in.	mm
24, 30, 36	47-5/8	1210	40-7/8	1038	47-5/8	1210	16-3/4	425	14	356	2	51	4-1/2	114	20-1/4	514
42, 48, 60	55-1/4	1403	44-7/8	1140	56-1/8	1426	19-1/2	495	19-1/2	495	2-1/8	54	10	254	25-7/8	657

  

Size	I		J		K		L		M		N		O	
	in.	mm	in.	mm	in.	mm	in.	mm	in.	mm	in.	mm	in.	mm
24, 30, 36	21	533	23-1/4	591	32-1/4	819	26-1/4	667	13-1/2	343	3-1/8	79	5-7/8	149
42, 48, 60	26-1/2	673	26-3/4	679	36-1/4	921	30-1/4	768	18-1/4	463	3-3/4	95	4-3/8	111

**CLIP CURB**

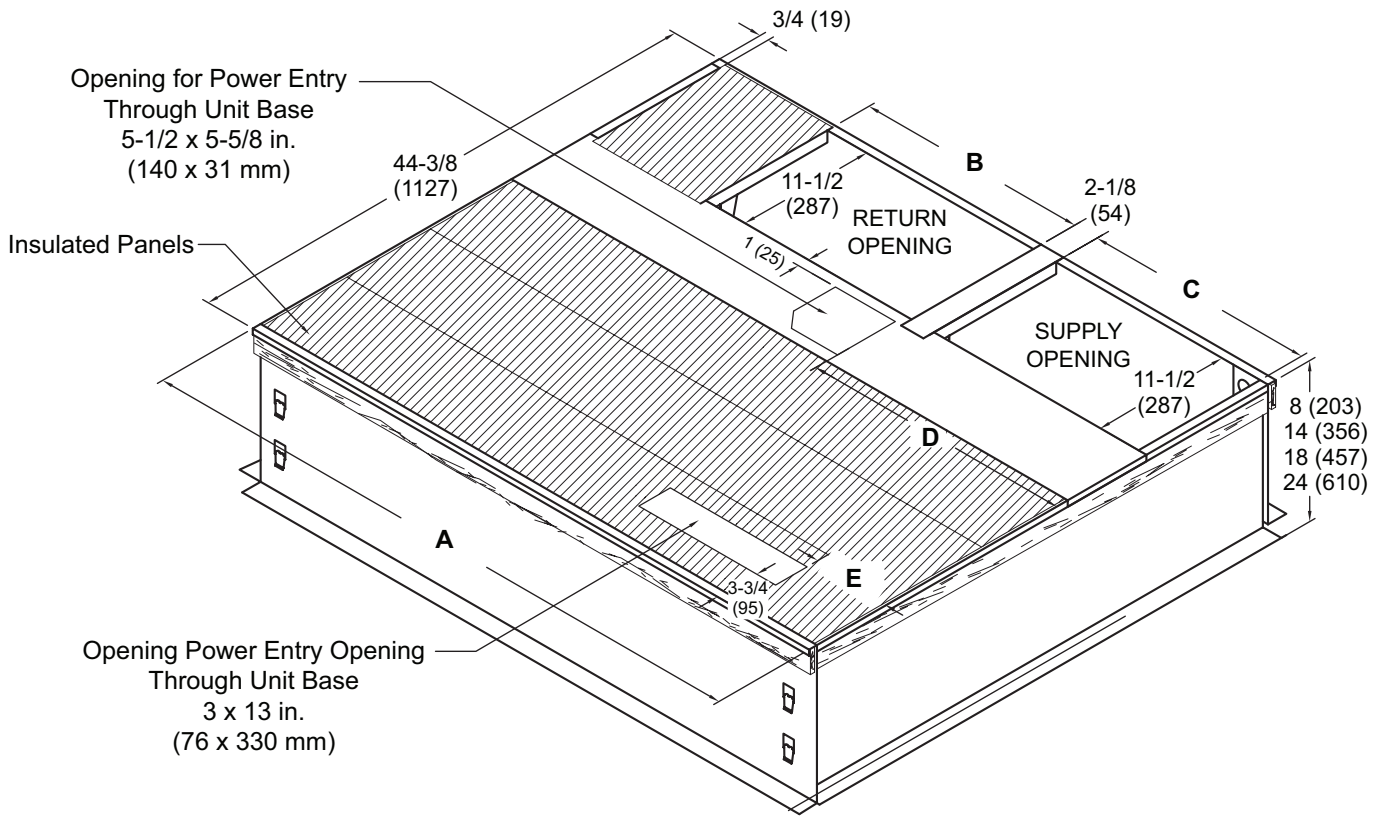

**TYPICAL FLASHING DETAIL FOR ROOF CURB**

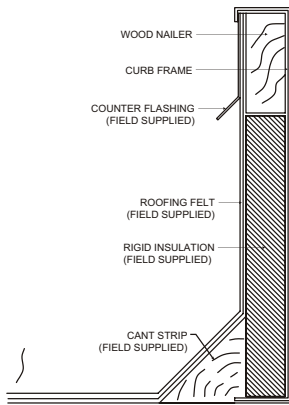

**DETAIL ROOF CURB**

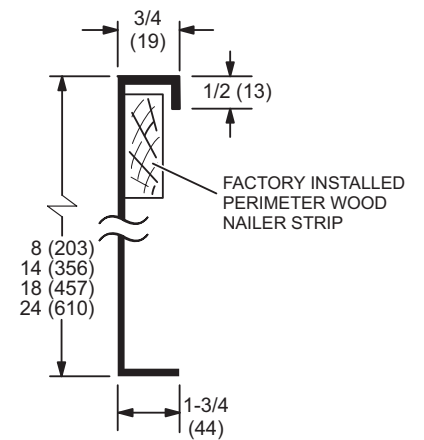

Usage	A		B		C		D		E	
	in.	mm	in.	mm	in.	mm	in.	mm	in.	mm
24, 30, 36	44-3/8	1127	16-7/8	429	13-7/8	352	17-1/4	438	1-1/4	32
42, 48, 60	52-7/8	1343	19-1/2	380	19-1/2	352	23-1/8	587	7	178

**ADJUSTABLE PITCH ROOF WELDED CURB**

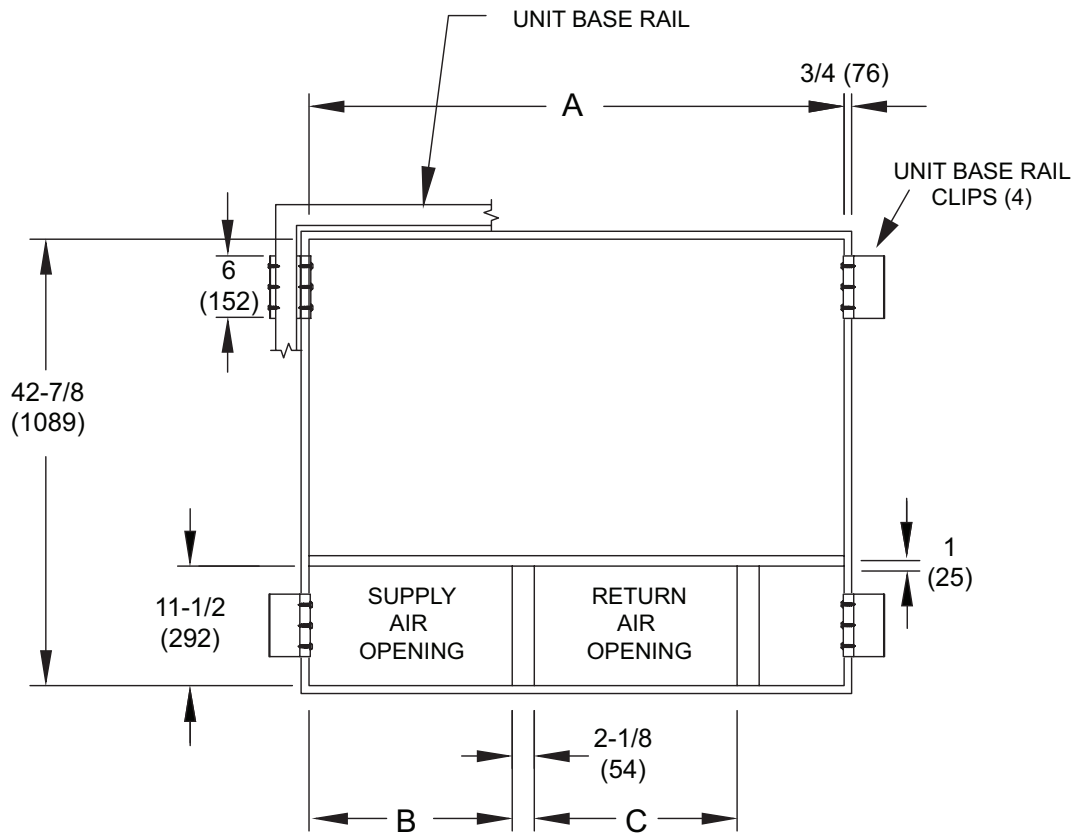
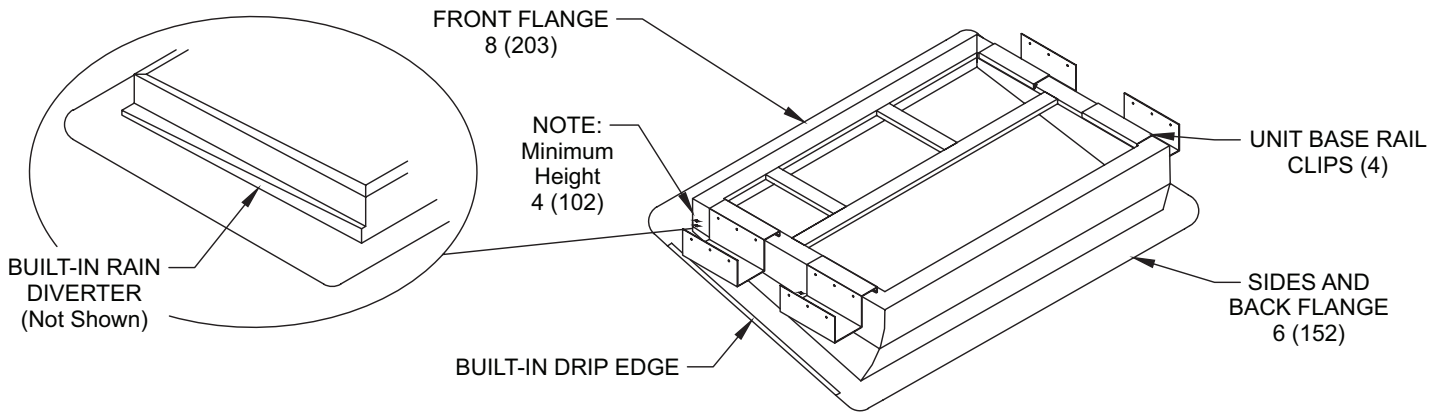

Usage	A		B		C	
	in.	mm	in.	mm	in.	mm
24, 30, 36	42-7/8	1089	13-7/8	352	16-7/8	429
42, 48, 60	51-3/8	1305	19-1/2	495	19-1/2	495

**ADJUSTABLE PITCH ROOF CLIP CURB**

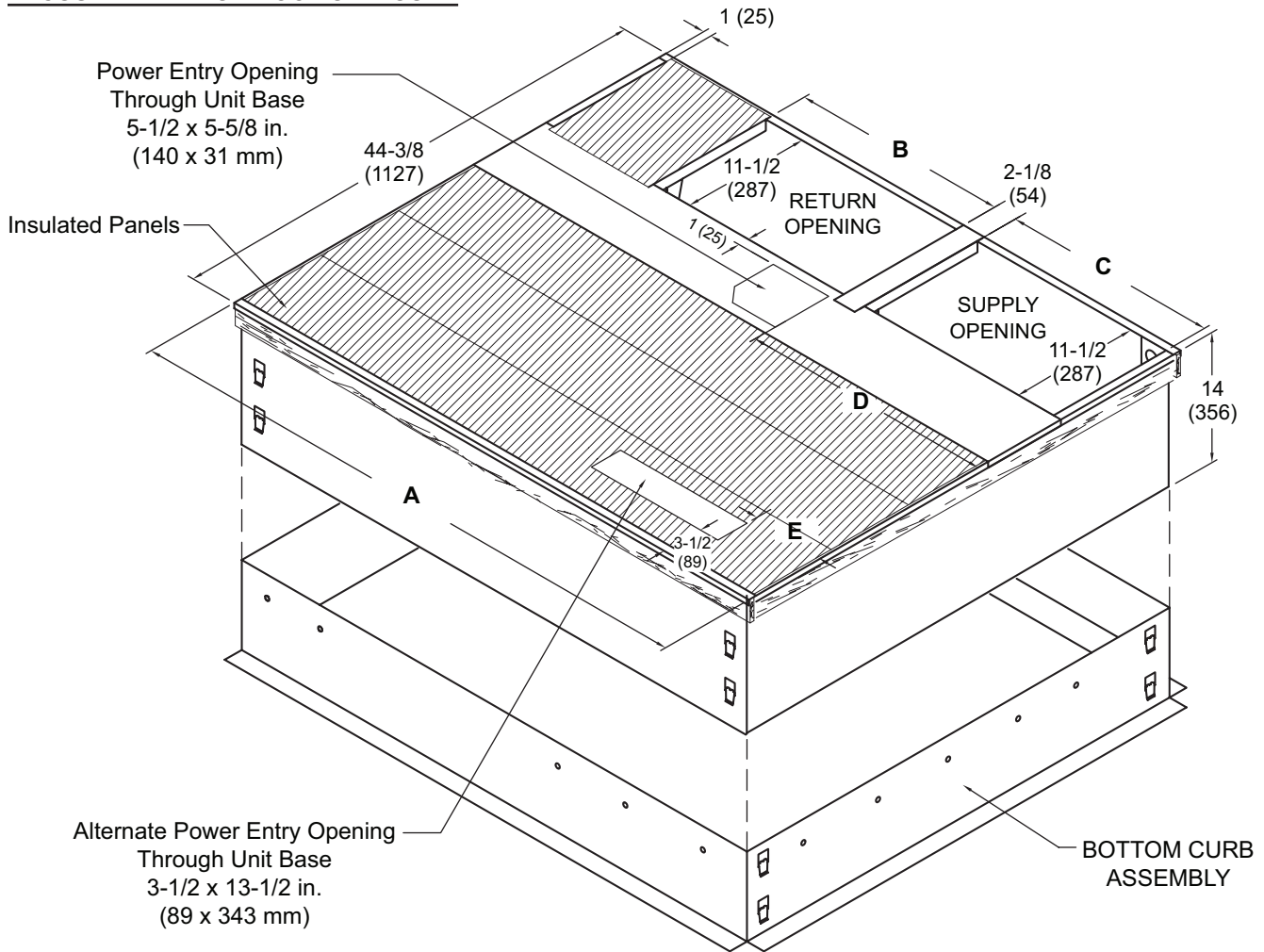

NOTE - Roof deck may be omitted within confines of curb.

**TYPICAL FLASHING DETAIL FOR ROOF CURB**

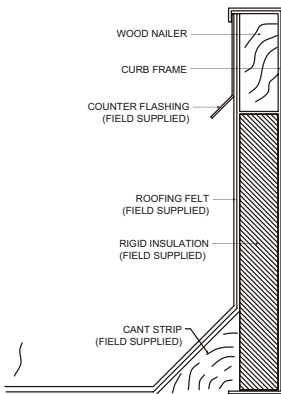

**DETAIL ROOF CURB**

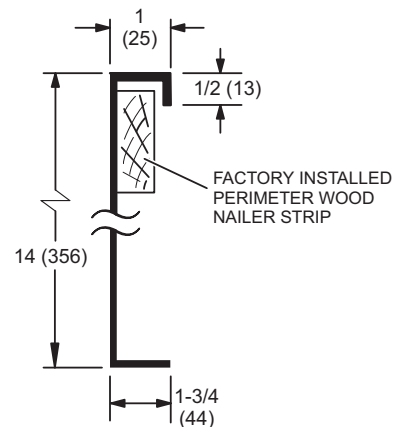

Usage	A		B		C		D		E	
	in.	mm	in.	mm	in.	mm	in.	mm	in.	mm
24, 30, 36	44-3/8	1127	16-7/8	429	13-7/8	352	17-1/4	438	1-1/4	32
42, 48, 60	52-7/8	1343	19-1/2	380	19-1/2	352	23-1/8	587	7	178



## REVISIONS

Sections	Description of Change
Control Options	Updated to reflect latest product offering.
Dimensions	Updated dimension table.



Visit us at [www.Lennox.com](http://www.Lennox.com)

For the latest technical information, [www.LennoxPros.com](http://www.LennoxPros.com)

Contact us at 1-800-4-LENNOX

NOTE - Due to Lennox' ongoing commitment to quality, Specifications, Ratings and Dimensions subject to change without notice and without incurring liability. Improper installation, adjustment, alteration, service or maintenance can cause property damage or personal injury. Installation and service must be performed by a qualified installer and servicing agency.

©2026 Lennox Industries, Inc.