



AA

BB

CC

DD

EE

FF

01

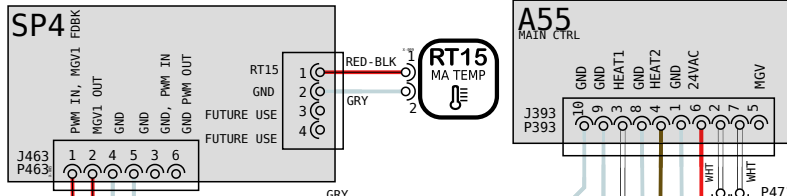

02

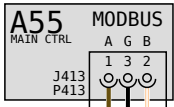

03

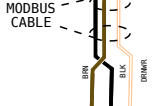

04

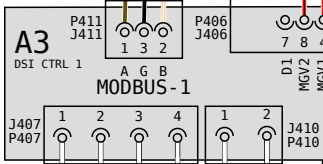

05

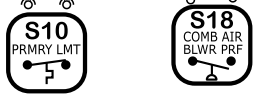

06

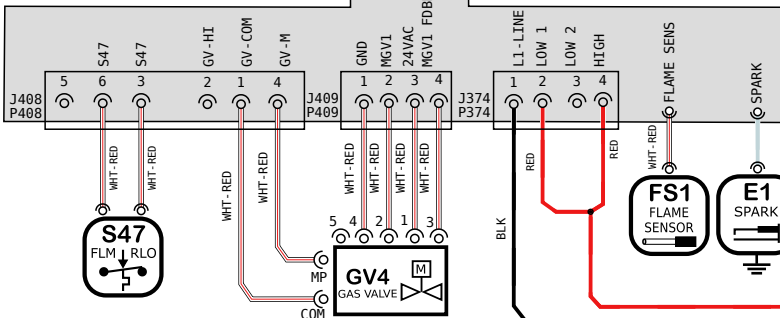

07

08

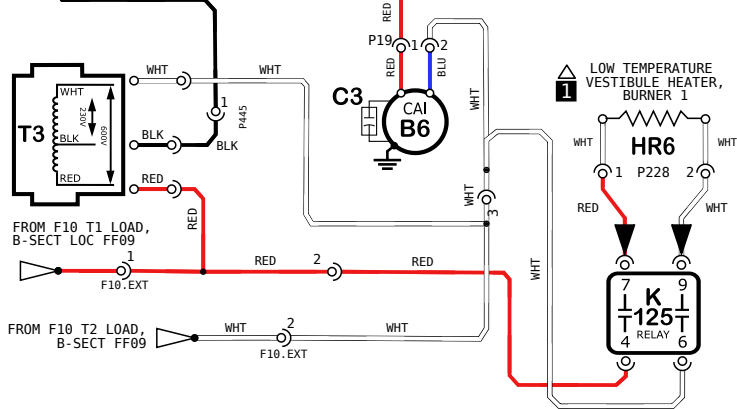

09

KEY LIST

LOCATION	COMPONENT DESCRIPTION
AA03/AA04	A3 CONTROL BOARD, DSI BOARD
AA02	A55 CONTROL BOARD, MAIN
DD04	B3 MOTOR, BLOWER
EE08	B6 MOTOR, COMBUSTION AIR IND., BURNER
DD08	C3 CAPACITOR, CAI MOTOR
DD07	E1 IGNITOR, SPARK BURNER
CC07	FS1 SENSOR, FLAME, BURNER
BB/CC07	GV4 VALVE, GAS, MODULATING 1
FF08	HR6 HEATER, -50 C LOW TEMP VEST, BURNER
FF05	K125 RELAY, LOW TEMP VEST HEATER, BURNER
FF09	K125 RELAY, LOW TEMP VEST HEATER, BURNER
DD01	RT15 SENSOR, MIXED AIR
AA06	S10 LIMIT, PRIMARY, BURNER
BB05	S18 SWITCH, COMB AIR BLWR PRF, BURNER
AA07	S47 SWITCH, FLAME ROLLOUT, BURNER
EE/FF03	S59 TSTAT, OPEN -20F, CLOSE 10F, BURNER
FF03	S60 TSTAT, OPEN 20F, CLOSE -10F, BURNER
FF04	S61 TSTAT, OPEN 50F, CLOSE 20F, BURNER

← DENOTES OPTIONAL COMPONENTS AND WIRING

NOTES

1 - 50C LOW TEMPERATURE VESTIBULE HEATER - OPTIONAL

10

Model: LG\*/LD\* Series RTU - MOD Gas Heat - J V0...  
 130k, 180k, 240k BtuH  
 Voltage: 575/3/60 (J)  
 Supersedes: XXXXX-XX Form No: 538655-01 Rev: 0

HEATING SECTION A	COOLING SECTION B	COOLING SECTION B3/5	ACCS SECTION C	ACCS SECTION D
-------------------	-------------------	----------------------	----------------	----------------

WIRING DIAGRAM FLOW

© 2019

7x10 CUT SIZE

REV	EC NO.	DATE	BY	APVD	REVISION NOTE
---	CN-013678	02-09-2026	FEP	MCF	ORIGINATED AT PD&R CARROLLTON, TX



AA

BB

CC

DD

EE

FF

01

02

03

04

05

06

07

08

09

10

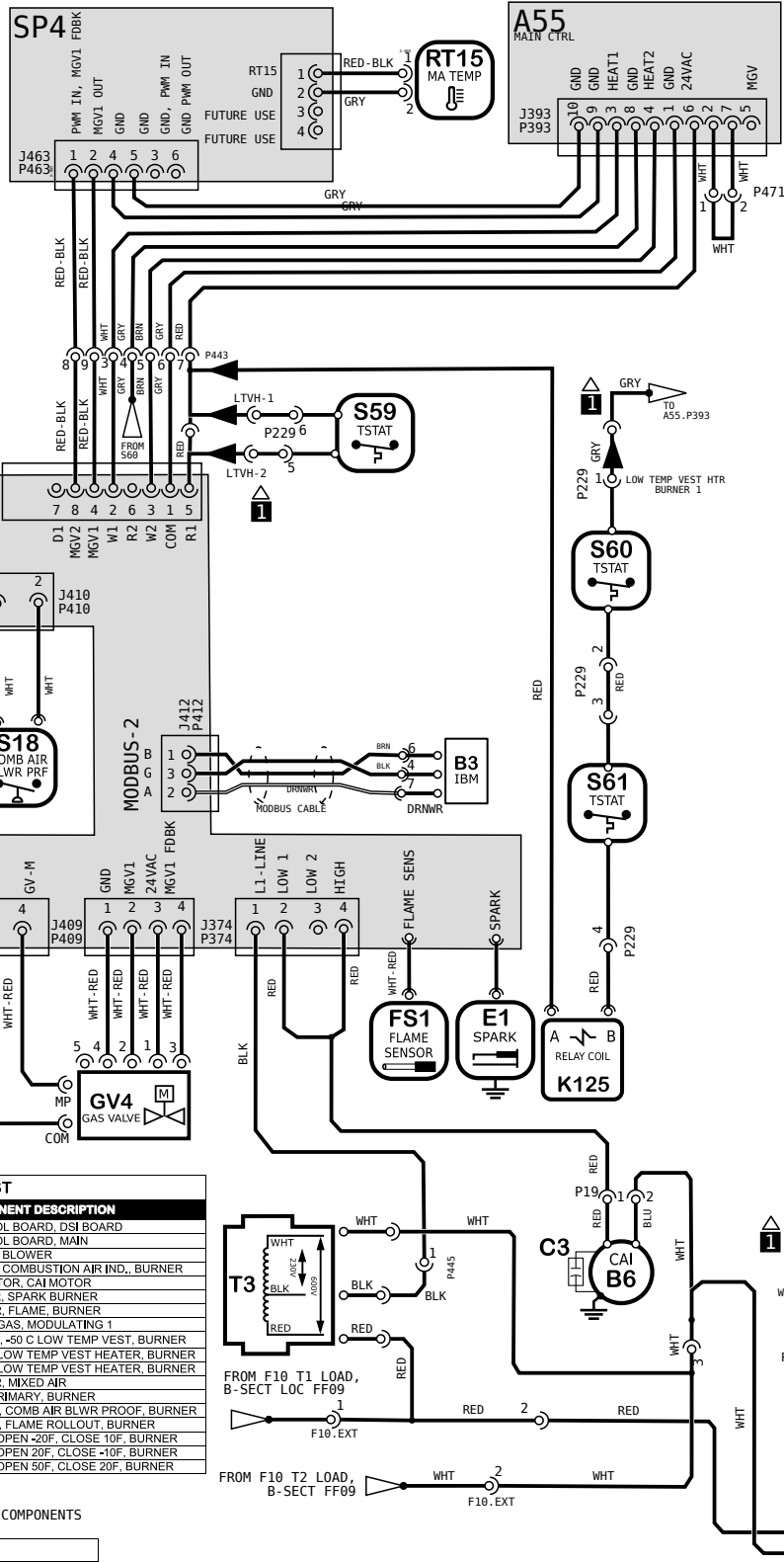

KEY LIST

LOCATION	COMPONENT DESCRIPTION
AA03/AA04	A3 CONTROL BOARD, DSI BOARD
AA02	A55 CONTROL BOARD, MAIN
DD04	B3 MOTOR, BLOWER
EE08	B6 MOTOR, COMBUSTION AIR IND., BURNER
DD08	C3 CAPACITOR, CAI MOTOR
DD07	E1 IGNITOR, SPARK BURNER
CC07	FS1 SENSOR, FLAME, BURNER
BB/CC07	GV4 VALVE, GAS, MODULATING 1
FF08	HR6 HEATER, -50 C LOW TEMP VEST, BURNER
FF05	K125 RELAY, LOW TEMP VEST HEATER, BURNER
FF09	K125 RELAY, LOW TEMP VEST HEATER, BURNER
DD01	RT15 SENSOR, MIXED AIR
AA06	S10 LIMIT, PRIMARY, BURNER
BB05	S18 SWITCH, COMB AIR BLWR PRF, BURNER
AA07	S47 SWITCH, FLAME ROLLOUT, BURNER
EE/FF03	S59 TSTAT, OPEN -20F, CLOSE 10F, BURNER
FF03	S60 TSTAT, OPEN 20F, CLOSE -10F, BURNER
FF04	S61 TSTAT, OPEN 50F, CLOSE 20F, BURNER

← DENOTES OPTIONAL COMPONENTS AND WIRING

NOTES

1 - 50C LOW TEMPERATURE VESTIBULE HEATER - OPTIONAL

Model: LG\*/LD\* Series RTU - MOD Gas Heat - J V0...  
 130k, 180k, 240k BtuH  
 Voltage: 575/3/60 (J)  
 Supersedes: XXXXX-XX Form No: 538655-01 Rev: 0

HEATING	COOLING	COOLING	ACCS	ACCS
SECTION A	SECTION B	SECTION B3/5	SECTION C	SECTION D

WIRING DIAGRAM FLOW

© 2019

7x10  
CUT SIZE

REV	EC NO.	DATE	BY	APVD	REVISION NOTE
---	CN-013678	02-09-2026	FEP	MCF	ORIGINATED AT PD&R CARROLLTON, TX