

# EL280DFE(K)

ELITE® SERIES

Upflow / Horizontal | Constant Torque Blower | Refrigerant Detection | 60Hz



RESIDENTIAL  
PRODUCT SPECIFICATIONS (EHB)

AFUE - 80%

Input - 66,000 to 88,000 Btuh

Nominal Add-on Cooling - 1.5 to 4 Tons

**ELITE**®  
SERIES



## MODEL NUMBER IDENTIFICATION

**EL 2 80 DF 070 E 36 A K**

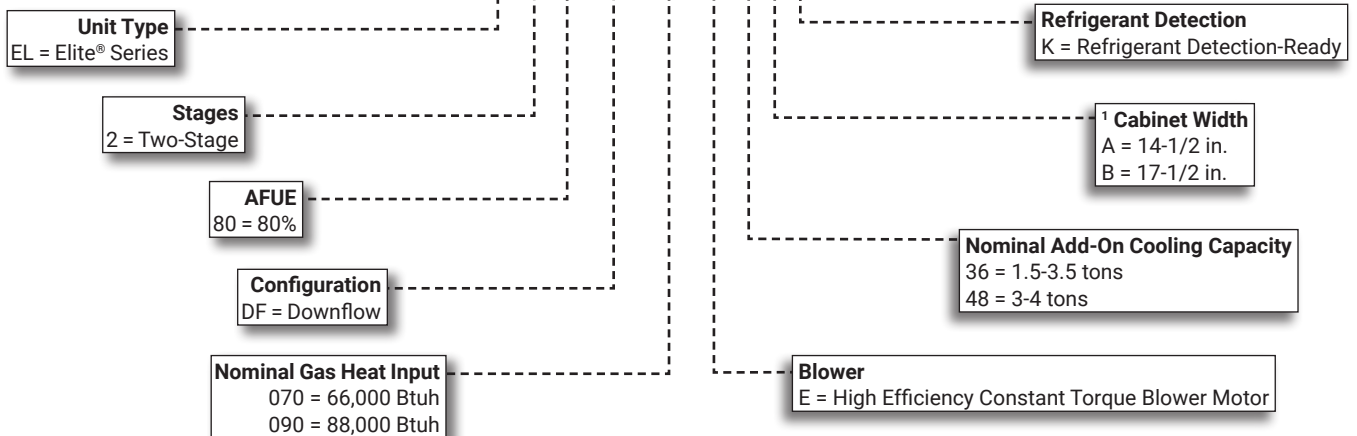

<sup>1</sup> Downflow indoor coils with the same letter designation will physically match the furnace supply air opening.

## FEATURE HIGHLIGHTS

1. Lennox Duralok™ Heat Exchanger
2. Inshot Burners
3. SureLight® Hot Surface Ignitor
4. Two-Stage Gas Control Valve
5. Two-Speed Combustion Air Inducer
6. Flame Rollout Switches
7. SureLight® Integrated Furnace Control
8. Power Saver™ Constant Torque Blower
9. Insulated Cabinet
10. Safety Interlock Switch
11. Gas Piping And Electrical Inlets

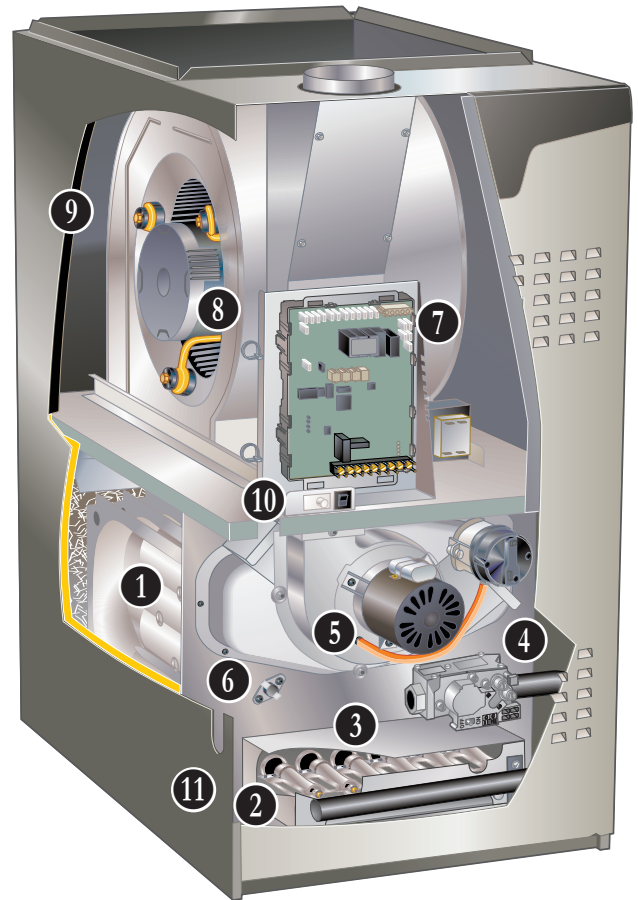

**NOTE - EL280DFE(K) FURNACES ARE NOT AVAILABLE IN CANADA!**  
**NOTE - EL280DFE(K) FURNACES CANNOT BE TWINNED!**

## CONTENTS

Blower Data . . . . .	14
Approvals And Warranty . . . . .	3
Control Options . . . . .	7
Dimensions . . . . .	11
- Furnace/Coil Combined Dimensions . . . . .	13
- Optional Accessories . . . . .	12
- Unit . . . . .	11
Features . . . . .	3
Gas Heat Accessories . . . . .	10
High Altitude Derate . . . . .	10
Indoor Air Quality Product Options . . . . .	7
Installation Clearances . . . . .	10
Model Number Identification . . . . .	1
Optional Accessories - Order Separately . . . . .	9
Specifications . . . . .	9

## APPROVALS AND WARRANTY

### APPROVALS

- AHRI Certified
- CSA International Certified
- Tested and rated according to US DOE test procedures and FTC labeling regulations
- ISO 9001 Registered Manufacturing Quality System
- Blower data from unit tests conducted in Lennox Laboratory air test chamber
- All models meet UL 60335-2-40 Refrigerant Detector Requirements

**NOTE** - This furnace has not been CSA International design certified for installation in mobile homes, recreational vehicles, or outdoors.

### California Only

- These furnaces **do not meet** the South Coast Air Quality Management District (SCAQMD) Rule 1111 and San Joaquin Valley Air Pollution Control District (SJVAPCD) Rule 4905 NOx emission limit (14 ng/J) and cannot be installed within the SCAQMD and SJVAPCD areas

### WARRANTY

- Duralok™ Aluminized Steel Heat Exchanger:
  - Limited twenty years in residential applications
  - Limited ten years in non-residential applications
- All other covered components:
  - Limited five years in residential installations
  - Limited one year in non-residential installations

**NOTE** - Refer to Lennox® Basic Limited Warranty at [www.Lennox.com](http://www.Lennox.com) for additional details.

## FEATURES

### APPLICATIONS

- Input capacities of 66,000 and 88,000 Btuh
- Energy efficiency (AFUE) -80%
- Lennox add-on indoor coils, high-efficiency air cleaners and humidifiers can easily be added to furnace
- Shipped factory assembled with all controls installed and wired
- Each unit factory test operated to ensure proper operation

### HEATING SYSTEM

- 1 Lennox Duralok™ Heat Exchanger Assembly**
  - Heavy gauge aluminized steel heat exchanger
  - Crimped seam clamshell type design
  - Designed for normal expansion and contraction
  - Minimum resistance to air flow
  - Heat exchanger has been laboratory life cycle tested in excess of industry standards
  - Compact size of heat exchanger permits low overall design of furnace cabinet
- 2 Inshot Burners**
  - Aluminized steel inshot burners provide efficient, trouble-free operation
  - Burner venturi mixes air and gas in correct proportion for proper combustion
  - Burner assembly is removable from the unit as a single component for ease of service
- 3 SureLight® Hot Surface Ignitor**
  - Tough, reliable, long-life, trouble-free performance
  - Silicon nitride ignitor
  - Cemented to steatite block for protection against current leakage
  - Ignition leads are constructed of nickel plated copper and are enclosed in high temperature Teflon® insulation for dependable operation
- 4 Two-Stage Gas Control Valve**
  - 24 volt redundant combination two-stage gas control valve combines manual shut off switch (On-Off), automatic electric valve (dual) and gas pressure regulation into a compact combination control
- 5 Two-Speed Combustion Air Inducer**
  - Heavy duty, permanent split capacitor (PSC) two-speed blower prepurges heat exchanger and safely vents flue products
  - Dual pressure switches (low fire/high fire) prove blower operation before allowing gas valve to open
  - Operates only during heating cycle
- 6 Flame Rollout Switch**
  - Factory installed on burner box
  - Switch provides protection from abnormal operating conditions
  - Manual reset

## FEATURES

### HEATING SYSTEM (continued)

#### Limit Controls

- Primary limit factory installed on vestibule panel
- Secondary limit factory installed on blower housing
- Automatic reset

#### Optional Accessories

##### High Altitude Pressure Switch Kit

- Required on most units for proper unit operation at altitudes from 4501 to 10,000 ft.

##### Natural Gas to LPG/Propane Conversion Kit

- Required for field changeover from natural gas to LPG/Propane

##### LPG/Propane to Natural Gas Conversion Kit

- Required for field changeover from LPG/Propane to natural gas

### CONTROLS

#### 7 SureLight® Integrated Two-Stage Furnace Control

- Contains all necessary controls and relays to operate furnace
- Combustion air inducer is operated by the integrated furnace control
- Prior to ignition, a pre-purge cycle for 15 seconds is initiated
- After the main burners are turned off, a post-purge cycle for 5 seconds is run
- **Safety Controls** - Flame sensor utilizes flame rectification for safe and reliable operation
- Should loss of flame occur, the integrated furnace control will initiate 4 re-attempts at ignition before locking out unit operation for 60 minutes
- Watchguard type circuit automatically resets ignition controls after one hour of continuous thermostat demand after unit lockout, eliminating nuisance calls for service
- **Thermostat Control** - For optimal performance, the use of a high-quality, digital two-stage thermostat with adjustable settings for first stage/second stage, on/off differentials and adjustable stage timers is recommended

#### Furnace Input Staging Options

Thermostat Type	Input Staging Available
<b>Two-Stage (Conventional)</b>	Determined by thermostat demand
<b>Single-Stage (Conventional)</b>	2nd-stage heat ON delay (DIP switch setting) OFF - 7 minutes (factory) ON - 12 minutes

- **Display LED** - Seven segment LED displays alpha-numeric information related to diagnostics as well as system operation and status
  - Diagnostic codes are held in non-volatile memory, immune from power interruptions
  - Holds up to ten diagnostic codes in order of occurrence for recall on demand
  - Port on blower door allows for easy viewing

#### DIP Switch Settings

- **Select Thermostat Used** - Single-Stage or Two-Stage
- Two selectable second stage recognition times (7 and 12 minutes) are available on the control when the furnace is used with a single-stage thermostat
- When used with a two-stage thermostat, furnace will only initiate second stage operation with a second stage thermostat demand
- **Second Stage Delay** - Used with single-stage thermostat only. See Furnace Input Staging Options table for details
- **Blower On/Off Time (Heating)** - Blower on time is fixed at 30 seconds, blower off time is adjustable from 90, 120, 180 and 210 seconds (factory setting - 120 seconds)
- **Blower On/Off Time (Cooling)** - For air-conditioning applications, blower "on" time is 2 seconds following thermostat demand for cooling
- Blower "off" time in cooling mode is adjustable from 2 or 45 seconds (factory setting - 45 seconds)
- For air-conditioning applications, blower is automatically energized on thermostat demand for cooling
- **Heating Speeds** - Low Heat or High Heat
- **Cooling Speeds** - Low Cool or High Cool
- **Continuous Speed** - Low Heat (factory setting) - adjustable
- **Dehumidification** - A jumper on the control must be clipped to enable dehumidification
- A humidity controlling thermostat or device is also required
- During a call for cooling, air volume is automatically reduced, forcing humidity removal by the air conditioner or heat pump system (single stage units or two-stage units running at 2nd stage)
- After the humidity has reached the desired set-point the cooling air volume returns to its designed rate
- **Dual-Fuel Operation** - A jumper on the control must be clipped to enable operation with a single or two-stage heat pump
- The indoor blower is started without delay when a call for heat is received

## FEATURES

### **CONTROLS (continued)**

- **Two-Stage Compressor Operation** - A jumper on the control must be clipped to enable operation with a two-stage compressor
- **Accessory Terminal** - One accessory terminal furnished for additional power supply requirements for 120 volt (less than 1 amp) powered air cleaners
- One un-powered pair of contacts are provided for humidifier connections and may be connected to 24V or 120V
- Control is factory installed in the unit control box

### **24 Volt Transformer (40VA)**

- Furnished and factory installed on outside of control box
- Circuit breaker (furnished) is wired in series

### **Field Wiring Make-up Box**

- Furnished for line voltage wiring
- Factory installed internally on left side of furnace
- Box may be installed internally on right side of furnace

### **Refrigeration Detection System (RDS)**

#### **(Part of the SureLight® Integrated Furnace Control)**

- Complies with UL 60335-2-40 approved standard
- Required for all systems using R-454B refrigerant
- Plug-in connection to the RDS Coil Sensor
- Supports up to two RDS Coil Sensors (factory setting)
- Used as an interface between indoor unit and thermostat to control system
- Ensures safe operation for systems equipped with R-454B refrigerant
- If R-454B refrigerant is detected, the refrigerant detection system will stop compressor and/or heating operation and operate the blower to reduce concentrations in the conditioned space
- Once safe levels are reached the HVAC system will resume normal operation
- Low GWP test button for troubleshooting
- Alarm/Zone relay interface can trigger an external alarm if R-454B refrigerant is detected and open all zone dampers (if part of a zoning system) if R-454B refrigerant is detected
- Power is disabled to non-communicating thermostats to prevent demand if R-454B refrigerant is detected
- On system start-up blower will run for five minutes and any thermostat demands are disabled

### **Optional Accessories**

#### **Thermostat**

- Thermostat is not furnished with unit
- See page 7

#### **Transformer (75VA)**

- Recommended when furnace is used with zoning or defrost thermostats and other 24V accessories requiring a higher VA rating
- Circuit breaker (furnished) is wired in series
- Replaces the standard 40VA transformer

### **BLOWER**

- Direct drive blower
- Statically and dynamically balanced
- Resiliently mounted
- Blower assembly easily removed for servicing

#### **8 Power Saver™ Constant Torque Blower Motor**

- DC Brushless Motor
- High Efficiency Constant Torque
- ECM (Electronically Commutated Motor)
- Motor is programmed to provide constant torque at each of the selectable speeds
- Motor is controlled by the Integrated Furnace Control
- Blower speeds are easily changed on the integrated furnace control
- See Blower Data tables

## FEATURES

### **CABINET**

- Low-profile, narrow width cabinet allows easy installation in downflow applications
- Heavy-gauge, cold rolled steel construction
- Pre-painted cabinet finish
- Flanges provided on return air opening for ease of plenum connection
- 9 • Insulated with foil faced insulation on sides and back of heating compartment and mat faced insulation in blower compartment
- Sealed blower compartment
- Inner blower compartment access panel seals blower compartment from air leakage
- Cabinet door can be removed without any tools
- Complete service access
- 10 • Safety interlock switch automatically shuts off power to unit when inner blower compartment access panel is removed
- 11 • Gas piping and electrical inlets are provided in both sides of cabinet

### **Coil Match-Up**

- All Lennox downflow indoor coils will physically match the furnace **supply air opening** with the same letter designation (A, B, C, D) as in the furnace model number

### **Low Leakage Cabinet**

- All models have less than 2% air leakage and meet ANSI/ASHRAE Standard 193-2010 "Method of Test for Determining the Air Tightness of HVAC Equipment"

### **Optional Accessories**

#### **Downflow Combustible Flooring Base**

- Required for heating only units installed on combustible flooring
- Not required in add-on cooling applications
- See Dimension drawing

### **FILTER (not furnished)**

- Filter and provisions for external mounting must be field provided

### **Optional Accessories**

#### **Downflow Filter Kit**

- Filter cabinet mounts directly on top of furnace
- "A" width cabinet includes one filter
- "B" width cabinets include two filters
- Filter rails are furnished
- Front access for servicing
- Cleanable filter(s) are furnished

## INDOOR AIR QUALITY PRODUCT OPTIONS

### Healthy Climate® PureAir® Air Purification System

- Filtration - The Carbon Clean 16® (MERV 16) media filter captures more than 95% of particles 0.3 microns and larger and more than 90% of particles 0.01 microns and larger
- Highest airflow performance and lowest pressure drop when compared to a leading brand.
- Long life filters up to 1 year



### Healthy Climate® Media Air Cleaner

- High performance in a narrow 7 in. cabinet
- Available with MERV 11, 13, or 16 rated filters
- Multi-position heavy gauge steel cabinet will support furnace/coil or air handler and associated duct work
- Tool-less entry
- Tool-less assembly for quick installation



### Healthy Climate® Whole Home In Duct Air Purifiers

- Compact Duct Mounted Design
- Effective against odors and VOC's
- Certified Ozone free
- UVC lamp and carbon cells



### Healthy Climate® Ultraviolet Germicidal Lights

- Compact duct mounted design
- Single or dual applications
- Certified ozone free
- Effective against odors to help keep the system clean
- Safety Interlocks (Additional UVC Compliance Kit for UL 60335-2-40 is available for A2L applications)
- Low power consumption
- Available for 24V or 110/230V
- Up to 1340 microwatts /cm<sup>2</sup> output (dual lamp model)



**NOTE** - Please refer to the individual Product Specifications for these products for full information.

## CONTROL OPTIONS

### E40 Smart Wi-Fi Thermostat

- 3 Htg.-2 Clg.
- 7-day, universal, programmable, touchscreen thermostat
- Controls dehumidification during cooling mode and humidification during heating mode
- Smooth Setback Recovery and compressor short-cycle protection
- One-Touch Away Mode, Smart Away™ (geo-fencing), equipment maintenance reminders and scheduling
- Smart home automation compatible with Apple HomeKit™, Amazon Alexa® and Google Assistant
- Lennox® Home App controls temperature, fan operation, set programs/schedules and set Away mode on a smartphone
- Lennox Smart Tech App allows the installer to commission the system and remotely turn the system on and off during setup or service call on a smartphone



### M40 Smart Wi-Fi Thermostat

- 3 Htg.-2 Clg.
- 7-day, universal, programmable, touchscreen thermostat
- Smooth Setback Recovery and compressor short-cycle protection
- One-Touch Away Mode, Smart Away™ (geo-fencing), equipment maintenance reminders and scheduling
- Smart home automation compatible with Apple HomeKit™, Amazon Alexa®, Google Assistant and Matter
- Lennox® Home App controls temperature, fan operation, set programs/schedules and set Away mode on a smartphone
- Lennox Smart Tech App allows the installer to commission the system and remotely turn the system on and off during setup or service call on a smartphone



**NOTE** - Please refer to the individual Product Specifications for these products for full information.

## INDOOR AIR QUALITY PRODUCT OPTIONS - ORDERING

**NOTE - Refer to the individual Product Specifications documents for additional accessories and maintenance items.**

Description	Dimensions	Furnace Width	Order Number
<b>PureAir® S Air Purification System</b>			
PCO3S-16-16	17-1/2 x 8-3/4 x 26-1/2	A/B/C	Y8904
PCO3S-20-16	21-1/8 x 8-3/4 x 26-1/2	C/D	Y8903
<b>Healthy Climate® Media Air Cleaner</b>			
HCC16-28 (Cabinet)	17-1/2 x 28-1/2 x 7	A/B/C	Y2920
HCC16-28 (Cabinet) 4-pack	17-1/2 x 28-1/2 x 7	---	Y2921
HCF16-16 (Filter) MERV 16	16 x 25 x 5	---	X6672
HCXF16-16 (Expandable Filter) MERV 16	16 x 25 x 5	---	X8306
HCF16-13 MERV 13	16 x 25 x 5	---	19L16
HCF16-11 (Filter) MERV 11	16 x 25 x 5	---	X6670
HCXF16-11 (Expandable Filter) MERV 11	16 x 25 x 5	---	X8303
HCC20-28 (Cabinet)	21 x 28-1/2 x 7	C/D	X6661
HCC20-28 (Cabinet) 4-pack	21 x 28-1/2 x 7	---	X7751
HCF20-16 (Filter) MERV 16	20 x 25 x 5	---	X6675
HCXF20-16 (Expandable Filter) MERV 16	20 x 25 x 5	---	X8307
HCF20-13 MERV 13	20 x 25 x 5	---	19L17
HCF20-11 (Filter) MERV 11	20 x 25 x 5	---	X6673
HCXF20-11 (Expandable Filter) MERV 11	20 x 25 x 5	---	X8304
<b>Healthy Climate® Whole Home In Duct Air Purifiers</b>			
HCWHAP1	8 x 7 x 16.5	---	23V99
<b>Healthy Climate® Ultraviolet Germicidal Lights</b>			
UVC-24V (24V) 17-1/2 in.	Ballast 4-3/4 x 2-1/4 x 2	---	X9423
UVC-41W-S (110/230V) 17-1/2 in.	Ballast 11-3/4 x 2-3/4 x 1-5/8	---	X9424
UVC-41W-D (110/230V) 17-1/2 in.	Ballast 11-3/4 x 2-3/4 x 1-5/8	---	X9425
<b>CONTROLS - ORDERING</b>			
E40 Smart Wi-Fi Thermostat	3-3/8 x 5-3/8 x 1	---	30L26
Lennox® Smart Room Sensor	4 x 5-1/2 x 3	---	22V25
Lennox® Smart Air Quality Monitor	3-5/8 x 4-3/8 x 1-3/8	---	21P02
Lennox® Wireless Extender	4 x 5-1/2 x 2-1/2	---	22V26
M40 Smart Wi-Fi Thermostat	3-5/16 x 4-5/16 x 7/8	---	30L27
<b>Thermostat Accessories</b>			
<sup>1</sup> Discharge Air Temperature Sensor (For S40, E40)			88K38
<sup>2</sup> Remote Outdoor Air Temperature Sensor (For dual-fuel and Humiditrol®)			X2658

<sup>1</sup> Optional for service diagnostics (E40).

<sup>2</sup> Remote Outdoor Air Temperature Sensor is used with conventional (non-Lennox® Communicating) outdoor units (sensor is furnished with Lennox® Communicating outdoor units). Allows the thermostat to display outdoor temperature. Required in dual-fuel and Humiditrol® applications.

## SPECIFICATIONS

Gas Heating Performance	Model	EL280DF070E36AK	EL280DF090E48BK
	<sup>1</sup> AFUE	80%	80%
<b>High Fire</b>	Input - Btuh	66,000	88,000
	Output - Btuh	52,000	69,000
	Temperature rise range - °F	30 - 60	35 - 65
	Gas Manifold Pressure (in. w.g.) Nat. Gas / LPG/Propane	3.5 / 10.0	3.5 / 10.0
<b>Low Fire</b>	Input - Btuh	43,000	57,000
	Output - Btuh	35,000	46,000
	Temperature rise range - °F	20 - 50	20 - 50
	Gas Manifold Pressure (in. w.g.) Nat. Gas / LPG/Propane	1.7 / 4.5	1.7 / 4.5
<b>High static - in. w.g.</b>	Heating	0.5	0.5
	Cooling	0.5	0.5
<b>Connections</b>	Flue connection - in. round	4	4
	Gas pipe size IPS	1/2	1/2
<b>Indoor Blower</b>	Wheel diameter x width - in.	10 x 8	10 x 10
	Motor output - hp	1/2	3/4
	Tons of add-on cooling	1.5 - 3.5	3 - 4
	Air Volume Range - cfm	400 - 1475	780 - 1700
<b>Electrical Data</b>	Voltage	120 volts - 60 hertz - 1 phase	
	Blower motor full load amps	6.4	9.3
	Maximum overcurrent protection	15	15
<b>Shipping Data</b>	lbs. - 1 package	123	142

NOTE - Filters and provisions for mounting are not furnished and must be field provided.

<sup>1</sup> Annual Fuel Utilization Efficiency based on DOE test procedures and according to FTC labeling regulations. Isolated combustion system rating for non-weatherized furnaces.

## OPTIONAL ACCESSORIES - ORDER SEPARATELY

	"A" Width Models	"B" Width Models
<b>CABINET</b>		
Downflow Combustible Flooring Base	11M59	11M60
<b>CONTROLS</b>		
Transformer (75VA)	27J32	27J32
<b>DOWNFLOW FILTER KITS</b>		
Downflow Filter Kit	51W06	51W07
No. and Size of filter - in.	(1) 20 x 20 x 1	(2) 20 x 16 x 1

## GAS HEAT ACCESSORIES

Input	High Altitude Pressure Switch Kit			Natural Gas to LPG/Propane Kit	LPG/Propane to Natural Gas Kit	Natural Gas High Altitude Orifice Kit	LPG/Propane High Altitude Orifice Kit
	0 - 4500 ft.	4501 - 7500 ft.	7501 - 10,000 ft.	0 - 7500 ft.	0 - 7500 ft.	7501 - 10,000 ft.	7501 - 10,000 ft.
070	No Change	No Change	73W36	11K51	77W09	73W37	11K46
090	No Change	No Change	73W36	11K51	77W09	73W37	11K46

## HIGH ALTITUDE DERATE

NOTE - Units may be installed at altitudes up to 4500 ft. above sea level without any modifications.

At altitudes above 4500 ft. units must be derated to match information in the shaded area shown below.

NOTE - This is the only permissible derate for these units.

Input	Gas Manifold Pressure (Outlet) in. w.g.											
	0 - 4500 Feet				4501 -7500 Feet				7501 - 10,000 ft.			
	Natural Gas		LPG/Propane		Natural Gas		LPG/Propane		<sup>1</sup> Natural Gas		LPG/Propane	
	High Fire	Low Fire	High Fire	Low Fire	High Fire	Low Fire	High Fire	Low Fire	High Fire	Low Fire	High Fire	Low Fire
070	3.5	1.7	10	4.5	3.2	1.5	10	4.5	3.5	1.7	10	4.5
090	3.5	1.7	10	4.5	3.0	1.5	10	4.5	3.5	1.7	10	4.5

<sup>1</sup> Natural Gas High Altitude Orifice Kit required.

## INSTALLATION CLEARANCES

Vent Type	Type B1	Type C
Sides	0 inches (0 mm)	<sup>1</sup> 0 inches (0 mm)
Rear	0 inches (0 mm)	0 inches (0 mm)
Top	1 inch (25 mm)	1 inch (25 mm)
Front	2-1/4 inches (57 mm)	2-1/4 inches (57 mm)
Front (alcove)	24 inches (610 mm)	24 inches (610 mm)
Front (service)	24 inches (610 mm)	24 inches (610 mm)
Floor	<sup>2</sup> Combustible	<sup>2</sup> Combustible
Flue	1 inch (25 mm)	6 inches (152 mm)

NOTE - Air for combustion must conform to the methods outlined in the National Fuel Gas Code (NFPA 54/ANSI-Z223.1).

NOTE - In the U.S. flue sizing must conform to the methods outlined in the current National Fuel Gas Code (NFPA 54/ANSI-Z223.1) or applicable provisions of local building codes.

<sup>1</sup> Left side requires 4 in. clearance if single wall vent is used on 14-1/2 in. "A" width cabinets, and 2 in. clearance on 17-1/2 in. "B" width cabinets.

<sup>2</sup> Clearance for installation on combustible floor if optional Downflow Combustible Flooring Base is installed between furnace and combustible floor. Not required in add-on cooling applications if installed in accordance with local codes or National Fuel Gas Code ANSI-Z223.1.

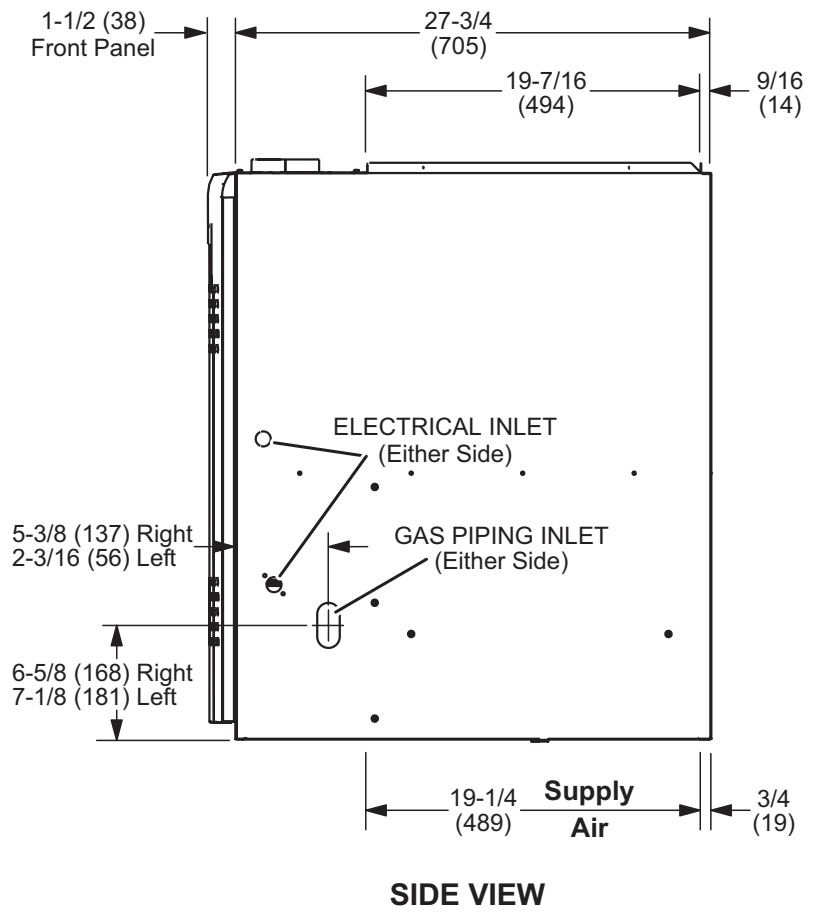
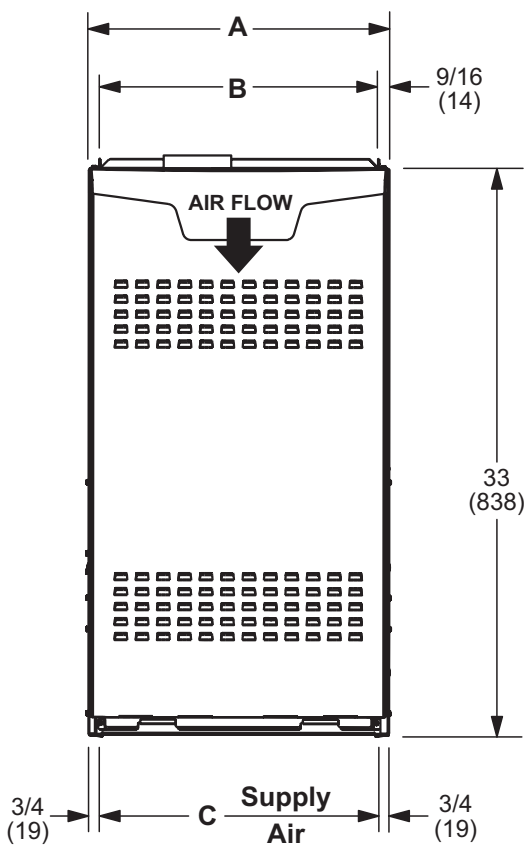
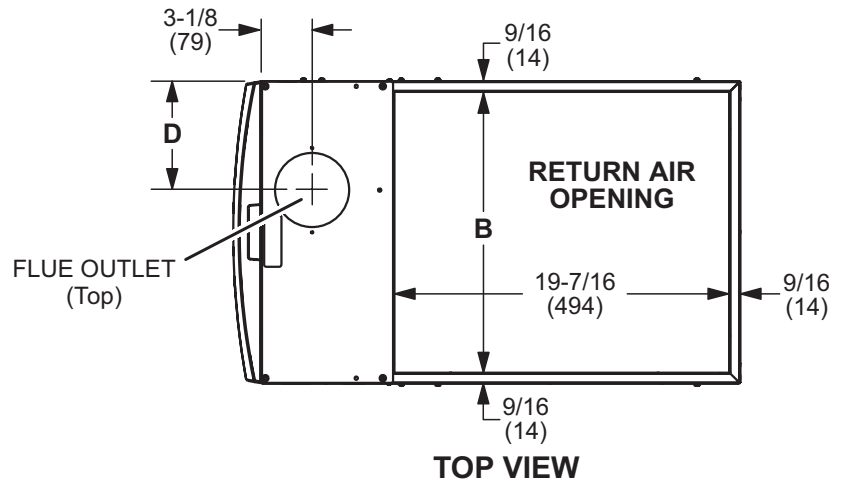

Model No.	A		B		C		D	
	in.	mm	in.	mm	in.	mm	in.	mm
EL280DF070E36AK	14-1/2	368	13-3/8	340	13	330	4-3/4	121
EL280DF090E48BK	17-1/2	446	16-3/8	416	16	406	6-1/4	159

**DOWNFLOW COMBUSTIBLE FLOORING BASE**

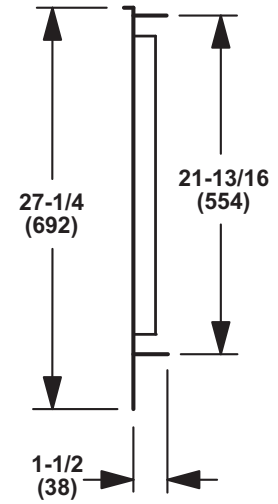
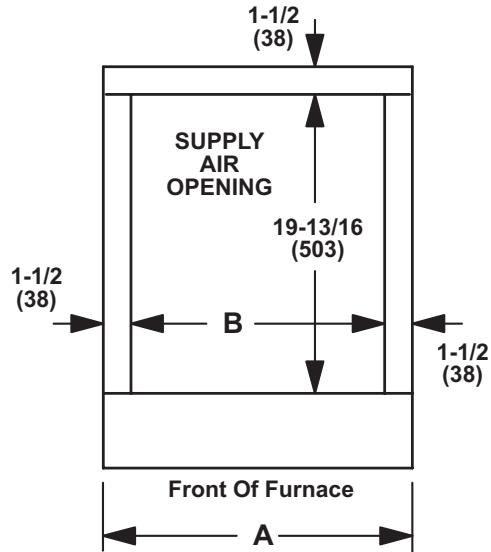
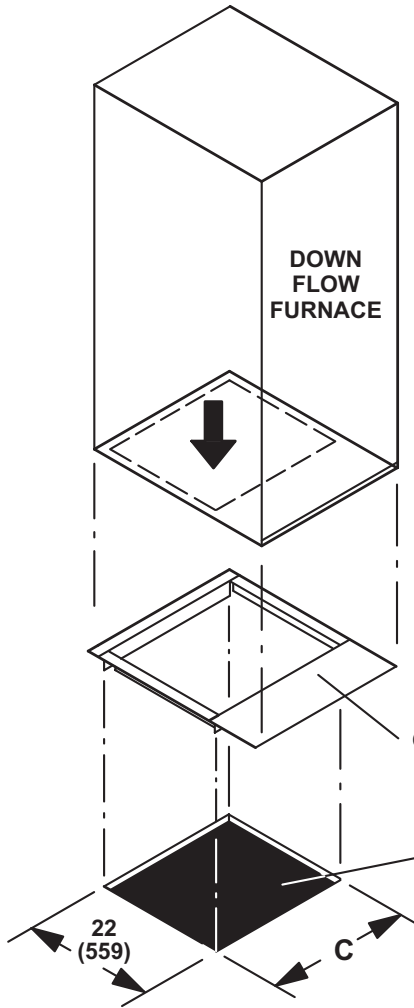

**TOP VIEW**

**SIDE VIEW**

Cabinet Width	Catalog Number	A		B		C	
		in.	mm	in.	mm	in.	mm
A	11M59	16-9/16	421	13-9/16	344	15-3/4	400
B	11M60	19-9/16	497	16-9/16	421	18-3/4	476

**DIMENSIONS**

**OPTIONAL ACCESSORIES**

**DOWNFLOW FILTER CABINET**

**“A” WIDTH FURNACES  
(Single Filter)**

**“B” WIDTH FURNACES  
(Two Filters)**

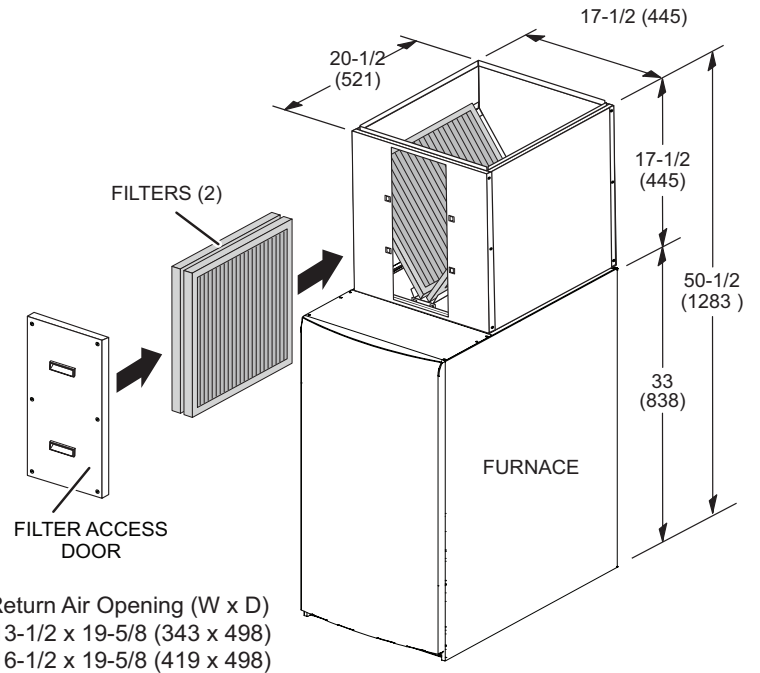
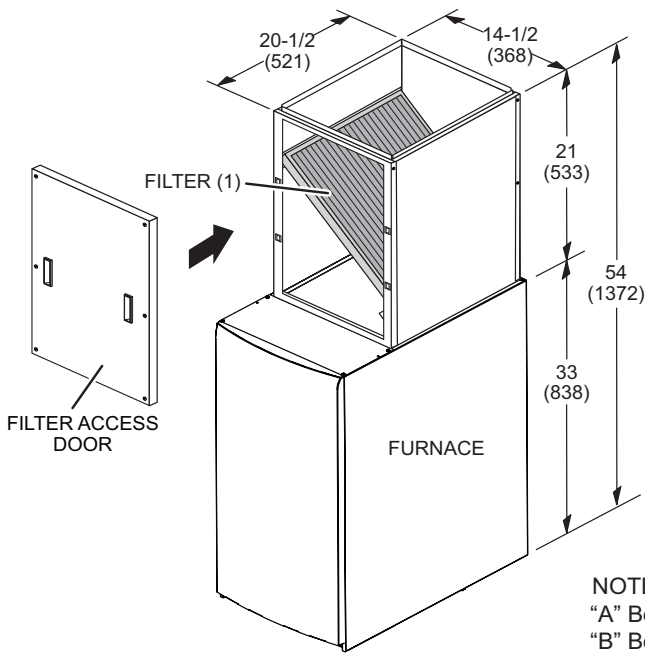

NOTE: Return Air Opening (W x D)  
 "A" Box 13-1/2 x 19-5/8 (343 x 498)  
 "B" Box 16-1/2 x 19-5/8 (419 x 498)

**DIMENSIONS**

**FURNACE/COIL COMBINED DIMENSIONS**

Model	Coil/Furnace Width		Coil Height		Overall Height	
	in.	mm	in.	mm	in.	mm
CK40DT	14-1/2	368	18	457	51	1295
CK40DT-24A	14-1/2	368	18	457	51	1295
CK40DT-24B	17-1/2	445	18	457	51	1295
CK40DT-30/36B	17-1/2	445	23-1/2	597	56-1/2	1435
CK40DT-42B	17-1/2	445	23-1/2	597	56-1/2	1435

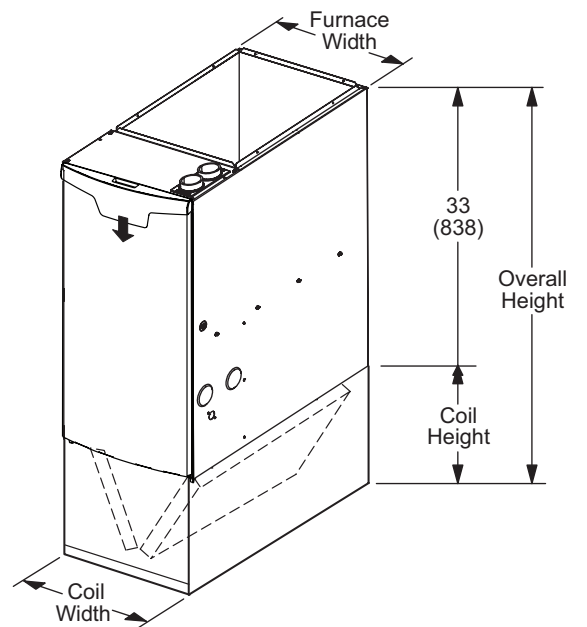

## BLOWER DATA

### EL280DF070E36AK PERFORMANCE (Less Filter)

External Static Pressure in. w.g.	Air Volume / Watts at Various Blower Speeds									
	High (Black)		Medium-High (Brown)		Medium (Blue)		Medium-Low (Yellow)		Low (Red)	
	cfm	Watts	cfm	Watts	cfm	Watts	cfm	Watts	cfm	Watts
0.10	1426	343	1298	265	1158	194	933	114	788	76
0.20	1406	353	1275	273	1132	201	904	119	751	81
0.30	1362	359	1251	282	1102	209	872	126	701	87
0.40	1347	366	1222	291	1076	216	814	132	673	91
0.50	1321	375	1193	300	1040	224	795	138	612	97
0.60	1295	384	1169	307	1013	231	756	143	531	103
0.70	1263	395	1142	315	983	239	715	149	492	107
0.80	1243	401	1117	323	942	248	660	155	439	111
0.90	1218	411	1088	331	909	255	619	161	397	116
1.00	1189	421	1055	341	897	258	582	165	333	121

### EL280DF090E48BK PERFORMANCE (Less Filter)

External Static Pressure in. w.g.	Air Volume / Watts at Various Blower Speeds									
	High (Black)		Medium-High (Brown)		Medium (Blue)		Medium-Low (Yellow)		Low (Red)	
	cfm	Watts	cfm	Watts	cfm	Watts	cfm	Watts	cfm	Watts
0.10	1734	421	1525	293	1405	237	1323	203	1198	158
0.20	1709	430	1498	302	1375	245	1288	209	1167	164
0.30	1669	444	1455	314	1344	253	1247	218	1116	172
0.40	1639	454	1428	323	1295	265	1218	224	1076	181
0.50	1608	464	1366	333	1267	271	1166	236	1031	188
0.60	1576	476	1349	340	1217	283	1133	243	995	195
0.70	1545	485	1316	350	1189	289	1095	250	936	204
0.80	1520	494	1282	359	1157	296	1044	260	923	208
0.90	1486	504	1256	366	1109	307	1017	265	843	216
1.00	1482	509	1223	374	1091	311	984	272	797	221



## REVISIONS

Sections	Description of Change
Control Options	Updated to reflect latest product offering.
Optional Accessories	Removed optional Twinning Panel.



Visit us at [www.lennox.com](http://www.lennox.com)

For the latest technical information, [www.LennoxPros.com](http://www.LennoxPros.com)

Contact us at 1-800-4-LENNOX

NOTE - Due to Lennox' ongoing commitment to quality, Specifications, Ratings and Dimensions subject to change without notice and without incurring liability. Improper installation, adjustment, alteration, service or maintenance can cause property damage or personal injury. Installation and service must be performed by a qualified installer and servicing agency.

©2026 Lennox Industries, Inc.