

INSTALLATION INSTRUCTIONS

⚠ WARNING

Improper installation, adjustment, alteration, service or maintenance can cause property damage, personal injury or loss of life. Installation and service must be performed by a licensed professional HVAC installer or equivalent, service agency, or the gas supplier

Table of Contents

Dimensions	4
Parts Arrangement	5
Shipping and Packing List	6
General	6
Requirements	6
Unit Support	8
Duct Connection	9
Rigging Unit for Lifting	9
Condensate Drains	9
Connect Gas Piping	10
Pressure Test Gas Piping	11
Electrical Connections - Power Supply	11
Electrical Connections - Control Wiring	12
Mobile Service App	14
Blower Operation and Adjustments	17
Refrigerant Leak Detection System	23
Cooling Start-Up	23
Heating Start-Up (LDT)	27
Gas Heating Operation	28
Gas Heating Checks and Adjustments	29
Heating Start-Up (LHT)	30

LHT/LDT156 (13 Ton)
LHT/LDT180 (15 Ton)
LHT/LDT240 (20 Ton)

HEAT PUMP AND DUAL-FUEL PACKAGED UNITS

508459-02

06/2026

Supersedes 508459-01

R-454B

Defrost Control	30
Multi-Staged Air Volume Start-Up	30
Multi-Staged Air Volume Operation	33
Hot Gas Reheat Start-Up	34
Diagnostic Sensors	36
RDS Sensors	38
Preventative Maintenance / Repair	40
Factory Unit Control Settings	48
Decommissioning	51

RETAIN THESE INSTRUCTIONS FOR FUTURE REFERENCE

Attention!

Use this QR code to download the mobile service app. Follow the prompts to pair the app with the Unit Controller. Refer to the "Mobile Service App" section in this manual. The QR code is also available in the unit control area.



The app can be downloaded from the appropriate iOS or Android store. Look for the following icon.



CAUTION

As with any mechanical equipment, contact with sharp sheet metal edges can result in personal injury. Take care while handling this equipment and wear gloves and protective clothing.

WARNING

Only manufacturer approved auxiliary devices are permitted to be installed in this unit.

WARNING

If this appliance is conditioning a space with an area smaller than T_{Amin} or stored in a space with an area smaller than A_{min} as defined by this instruction, then that space must be without continuously operating open flames (e.g. an operating gas appliance) or other potential ignition sources (e.g. an operating electric heater or similar hot surface). A flame-producing device may be installed in the same space if the device is provided with an effective flame arrest system.

CAUTION

Auxiliary devices which may be a potential ignition source shall not be installed in the duct work. Examples of such potential ignition sources are hot surfaces with a temperature exceeding 700°C and electric switching devices.

CAUTION

The appliance is not to be used by persons (including children) with reduced physical, sensory or mental capabilities, or lack of experience and knowledge, unless they have been given supervision or instruction

CAUTION

Children should be supervised not to play with the appliance.

CAUTION

Any personnel installing, decommissioning, or performing maintenance on the unit must be properly trained with A2L refrigerants.

CAUTION

Servicing shall be performed only as recommended by the manufacturer.

WARNING

•This appliance must be installed in accordance with local and national wiring regulations.

•If the appliance is not fitted with an option for full disconnection from power, a means of disconnection must be incorporated in the fixed wiring in accordance with national and local wiring regulations.

CAUTION

Leak Detection System installed. Unit must be powered except for service.

WARNING

•Do not use means to accelerate the defrosting process or to clean, other than those recommended by the manufacturer.

•The appliance shall be stored in a room without continuously operating ignition sources (for example: open flames, an operating gas appliance, or an operating electric heater).

•Do not pierce or burn.

•Be aware that refrigerants may not contain an odor

WARNING

Ducts connected to an appliance shall not contain a potential ignition source.

IMPORTANT

Pipe work, including piping material, pipe routing, and installation shall include protection from physical damage in operation and service, and be in compliance with national and local codes and standards, such as ASHRAE 15, ASHRAE 15.2, IAPMO Uniform Mechanical Code, ICC International Mechanical Code, or CSA B52. All field joints shall be accessible for inspection prior to being covered or enclosed.

IMPORTANT

Refrigerant sensors for refrigerant detection systems shall only be replaced with sensors specified by the appliance manufacturer.

CAUTION

This unit is equipped with electrically powered safety measures. To be effective, the unit must be electrically powered at all times after installation, other than when servicing.

A2L Refrigerant Considerations

Ensure that the work area is adequately ventilated before breaking into the system or conducting any hot work. A degree of ventilation shall continue during the period that the work is carried out. The ventilation should safely disperse any released refrigerant and preferably expel it externally into the atmosphere.

Check that cabling will not be subject to wear, corrosion, excessive pressure, vibration, sharp edges or any other adverse environmental effects, taking into account the effects of aging or continual vibration from sources such as compressors or fans.

Under no circumstances shall potential sources of ignition be used when searching for or detection of refrigerant leaks. A halide torch (or any other detector using a naked flame) shall not be used. Electronic leak detectors may be used to detect refrigerant leaks but, in the case of flammable refrigerants, the sensitivity may not be adequate, or may need re-calibration. (Detection equipment shall be calibrated in a refrigerant-free area.) Ensure that the detector is not a potential source of ignition and is suitable for the refrigerant used. Leak detection equipment shall be set at a percentage of the LFL of the refrigerant and shall be calibrated to the refrigerant employed, and the appropriate percentage of gas (25 % maximum) is confirmed. Leak detection fluids are also suitable for use with most refrigerants but the use of detergents containing chlorine shall be avoided as the chlorine may react with the refrigerant and corrode the copper pipe-work. If a leak is suspected, all naked flames shall be removed/extinguished. If a leakage of refrigerant is found which requires brazing, all of the refrigerant shall be recovered from the system, or isolated (by means of shut off valves) in a part of the system remote from the leak.

When breaking into the refrigerant circuit to make repairs – or for any other purpose – conventional procedures shall be used. However, for flammable refrigerants it is important that best practices be followed since flammability is a consideration. The following procedure shall be adhered to:

- Safely remove refrigerant following local and national regulations.
- Evacuate the circuit.
- Purge the circuit with inert gas.
- Evacuate.
- Purge the circuit with inert gas.
- Open the circuit

The refrigerant charge shall be recovered into the correct recovery cylinders if venting is not allowed by local and national codes. For appliances containing flammable refrigerants, the system shall be purged with oxygen-free nitrogen to render the appliance safe for flammable refrigerants. This process might need to be repeated several times. Compressed air or oxygen shall not be used for purging refrigerant systems. Refrigerants purging shall be achieved by breaking the vacuum in the system with oxygen-free nitrogen and continuing to fill until the working pressure is achieved, then venting to atmosphere, and finally pulling down to a vacuum. This process shall be vented down to atmospheric pressure to enable work to take place. Ensure that the outlet for the vacuum pump is not close to any potential ignition sources and that ventilation is available.

⚠ WARNING

To prevent serious injury or death:

- 1- Lock-out/tag-out before performing maintenance.
- 2- If system power is required (e.g., smoke detector maintenance), disable power to blower, remove fan belt where applicable, and ensure all controllers and thermostats are set to the OFF position before performing maintenance.
- 3- Always keep hands, hair clothing, jewelry, tools, etc., away from moving parts.

LHT/LDT Dimensions

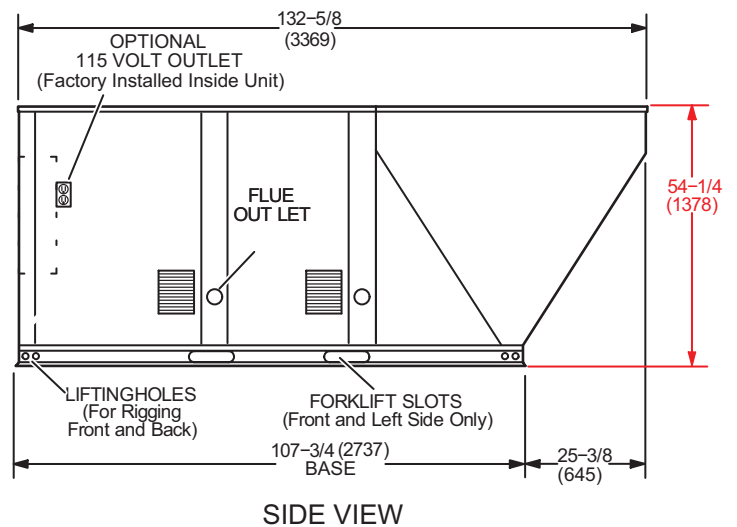
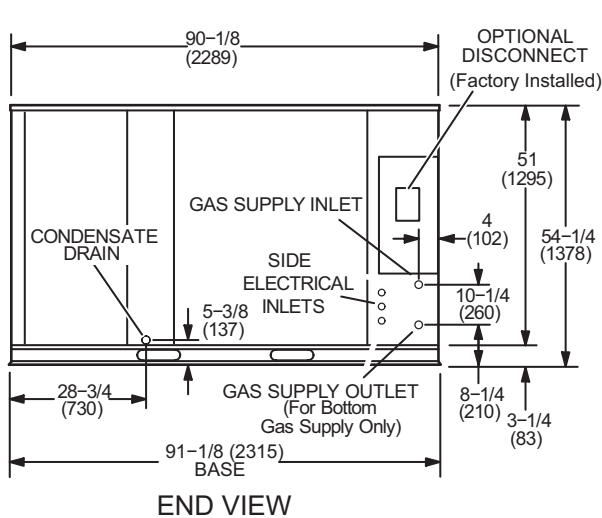
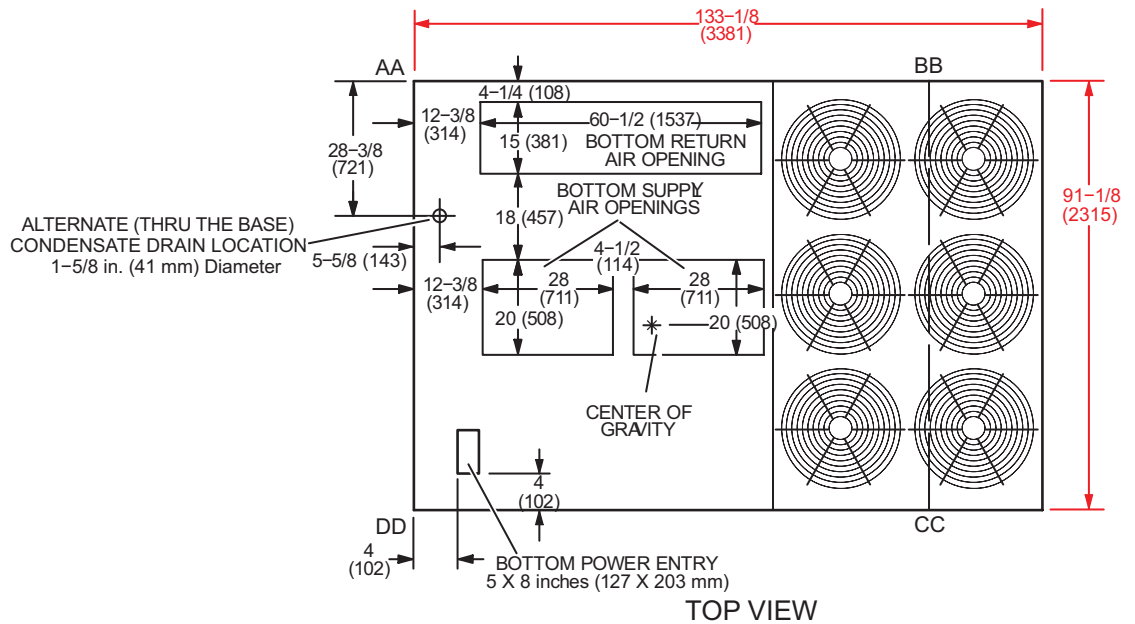

LHT156, 180, 240 Parts Arrangement

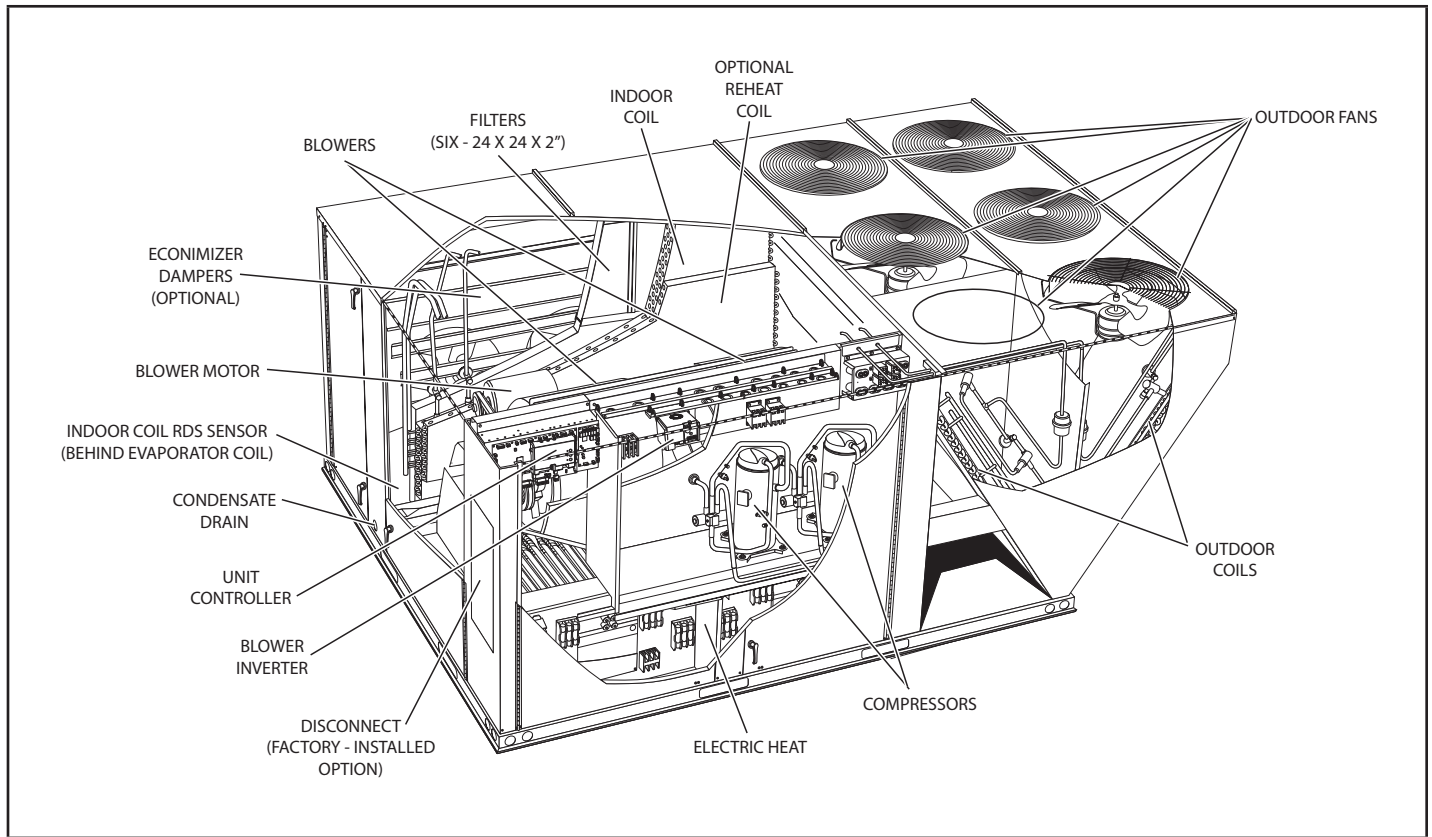

LDT156, 180, 240 Parts arrangement

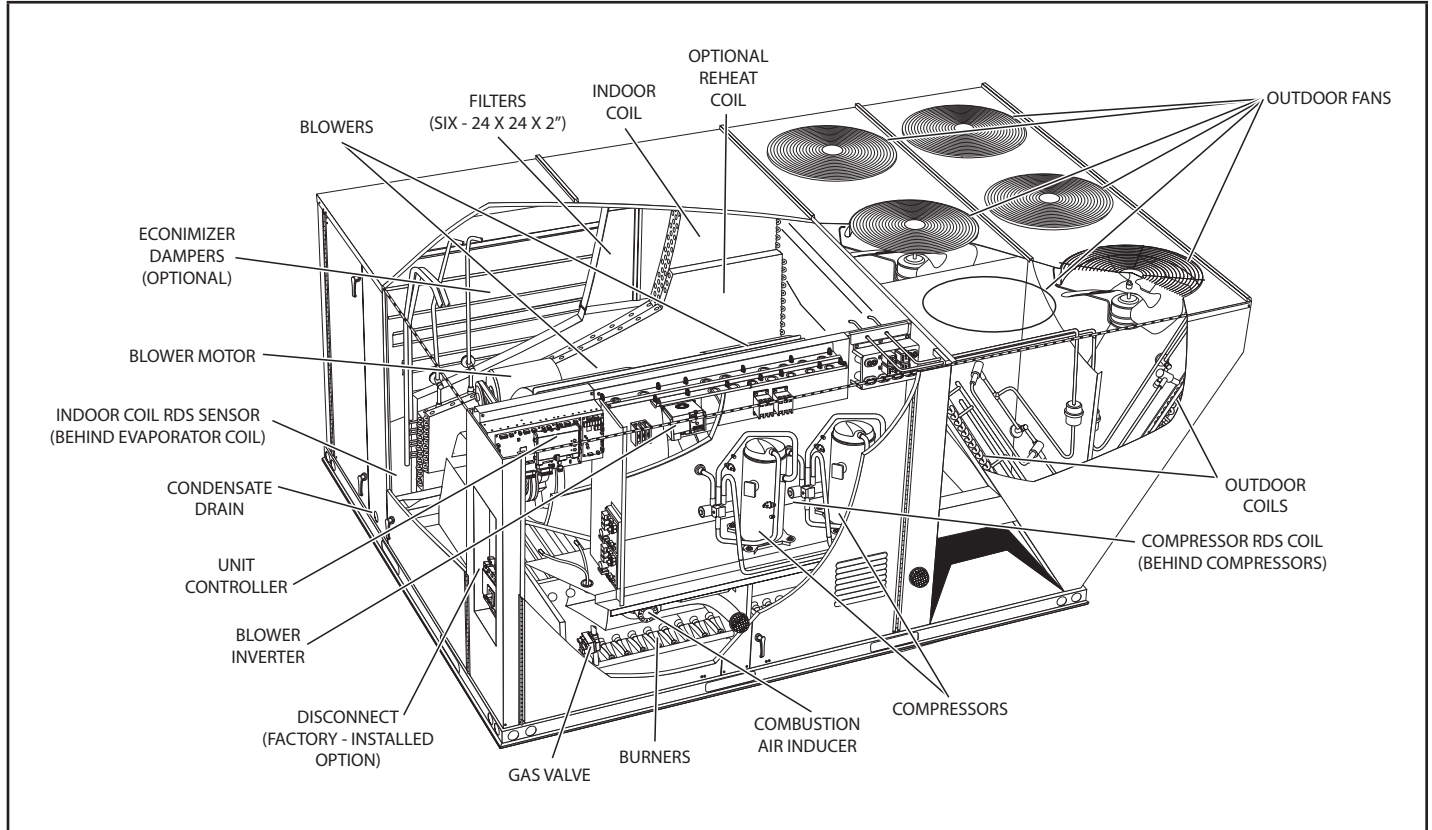

Shipping and Packing List

Package 1 of 1 contains:

- 1 - Assembled unit

Check unit for shipping damage. Receiving party should contact last carrier immediately if shipping damage is found.

General

These instructions are intended as a general guide and do not supersede local codes in any way. Authorities having jurisdiction should be consulted before installation.

LHT packaged heat pump and LDT packaged dual-fuel units have identical refrigerant circuits with respective 13-, 15-, and 20-ton cooling capacities. Units contain two compressors; compressor 1 is two-speed and compressor 2 is fixed speed.

Units are equipped with factory-installed fin/tube outdoor coils.

Optional electric heat is factory- or field-installed in LHT units.

The LDT156 unit is available in 169,000, 260,000, and 360,000 Btuh heating inputs. LDT180 and 240 units are available in 169,000, 260,000, 360,000, and 480,000 Btuh heating inputs.

Units are available with an optional hot gas reheat coil which provides a dehumidifying mode of operation. Refer to Reheat Operation section.

Units are available with multi-staged air volume.

Units use R454B, an ozone-friendly HFC refrigerant. Refer to the Cooling Start-Up section for precautions when installing unit.

⚠ WARNING



Electric shock hazard and danger of explosion. Can cause injury, death or product or property damage. Turn off gas and electrical power to unit before performing any maintenance or servicing operations on the unit. Follow lighting instructions attached to unit when putting unit back into operation and after service or maintenance.

Requirements

See FIGURE 1 for unit clearances.

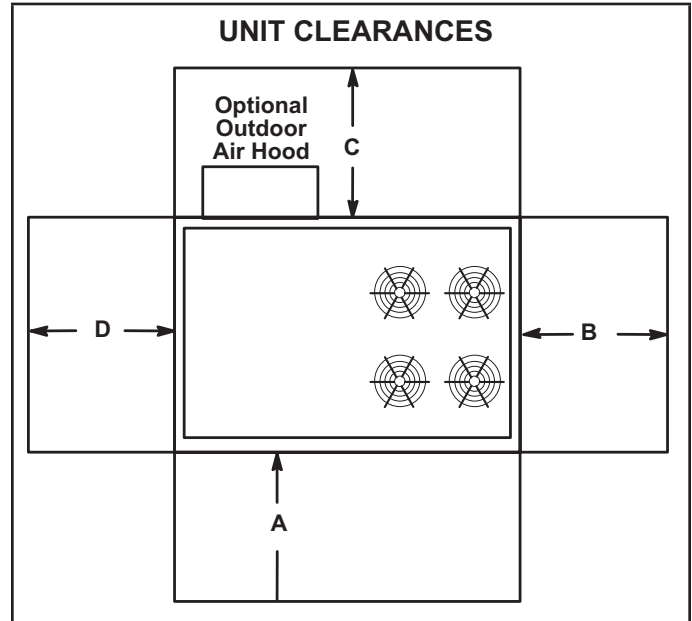

FIGURE 1

¹ Unit Clearance	A in.(mm)	B in.(mm)	C in.(mm)	D in.(mm)	Top Clearance
Service Clearance	60 (1524)	36 (914)	36 (914)	66 (1676)	Unobstructed
Clearance to Combustibles	36 (914)	1 (25)	1 (25)	1 (25)	Unobstructed
Minimum Operation Clearance	36 (914)	36 (914)	36 (914)	41 (1041)	Unobstructed

NOTE - Entire perimeter of unit base requires support when elevated above mounting surface.

¹**Service Clearance** - Required for removal of serviceable parts
Clearance to Combustibles - Required clearance to combustible material (gas units).

Minimum Operation Clearance - Required clearance for proper unit operation.

Minimum R454B Space and CFM Requirements

Minimum Airflow ¹		
Unit	Q _{min} (CFM)	Q _{min} (m ³ /h)
LHT/LDT156	555	943
LHT/LDT180	608	1033
LHT/LDT240	548	932
LHT/LDT156 w/ Humiditrol	634	1078
LHT/LDT180 w/ Humiditrol	648	1100
LHT/LDT240 w/ Humiditrol	588	999

¹ **NOTE** - The minimum airflow is the lowest CFM allowed during venting operation (leak mitigation).

Minimum Room Area of Conditioned Space ²		
Unit	TA _{min} (ft ²)	TA _{min} (m ²)
LHT/LDT156	308	28.58
LHT/LDT180	337	31.30
LHT/LDT240	304	28.24
LHT/LDT156 w/ Humiditrol	352	32.66
LHT/LDT180 w/ Humiditrol	359	33.34
LHT/LDT240 w/ Humiditrol	326	30.28

² **NOTE** - The minimum room area of conditioned space is the smallest area the unit can service.

Refrigerant Charge R-454B		
Unit	M _c (lbs)	M _c (kg)
LHT/LDT156 Stage 1	21.00	9.53
LHT/LDT156 Stage 2	19.00	8.62
LHT/LDT180 Stage 1	23.00	10.43
LHT/LDT180 Stage 2	19.50	8.85
LHT/LDT240 Stage 1	20.75	9.41
LHT/LDT240 Stage 2	19.25	8.73
LHT/LDT156 Stage 1 w/ Humiditrol	24.00	10.89
LHT/LDT156 Stage 2 w/ Humiditrol	18.00	8.16
LHT/LDT180 Stage 1 w/ Humiditrol	24.50	11.11
LHT/LDT180 Stage 2 w/ Humiditrol	19.00	8.62
LHT/LDT240 Stage 1 w/ Humiditrol	22.25	10.09
LHT/LDT240 Stage 2 w/ Humiditrol	21.50	9.75

Altitude Adjustment Factor ³									
Halt	0	200	400	600	800	1000	1200	1400	1600
AF	1	1	1	1	1.02	1.05	1.04	1.1	1.12
Halt	1600	1800	2000	2200	2400	2600	2800	3000	3200
AF	1.12	1.15	1.18	1.21	1.25	1.28	1.32	1.36	1.4

³ **NOTE** - Use the Altitude Adjustment Factor to adjust the values in the tables above to different altitudes. Find the relevant altitude above sea level in the two "Halt" rows and then multiply the value needed from the tables above by the altitude factor number. Example: For the minimum airflow in CFM for an LHT/LDT156 at 1000 ft. above sea level, multiply 555 by 1.05 to get 582.75 CFM as the new Q_{min}.

NOTICE

Roof Damage!

This system contains both refrigerant and oil. Some rubber roofing material may absorb oil, causing the rubber to swell. Bubbles in the rubber roofing material can cause leaks. Protect the roof surface to avoid exposure to refrigerant and oil during service and installation. Failure to follow this notice could result in damage to roof surface.

Use of this unit as a construction heater or air conditioner is not recommended during any phase of construction. Very low return air temperatures, harmful vapors and operation of the unit with clogged or misplaced filters will damage the unit.

If this unit has been used for heating or cooling of buildings or structures under construction, the following conditions must be met or the warranty will be void:

- The vent hood must be installed per these installation instructions.
- A room thermostat must control the unit. The use of fixed jumpers that will provide continuous heating or cooling is not allowed.
- A pre-filter must be installed at the entry to the return air duct.
- The return air duct must be provided and sealed to the unit.
- Return air temperature range between 55°F (13°C) and 80°F (27°C) must be maintained.
- Air filters must be replaced and pre-filters must be removed upon construction completion.
- The input rate and temperature rise must be set per the unit rating plate.
- The heat exchanger, components, duct system, air filters and indoor coil must be thoroughly cleaned following final construction clean-up.
- The unit operating conditions (including airflow, cooling operation, ignition, input rate, temperature rise and venting) must be verified according to these installation instructions.

This appliance is not intended for use by persons (including children) with reduced physical, sensory, or mental capabilities, or lack of experience and knowledge, unless they have been given supervision or instruction concerning use of the appliance by a person responsible for their safety.

Unit Support

In downflow discharge installations, install the unit on a non-combustible surface only. Unit may be installed on combustible surfaces when used in horizontal discharge applications or in downflow discharge applications when installed on an LARMF18/36 roof mounting frame.

NOTE - Securely fasten roof frame to roof per local codes.

CAUTION

To reduce the likelihood of supply / return air by pass and promote a proper seal with the RTU, duct work / duct drops / diffuser assemblies must be supported independently to the building structure.

A-Downflow Discharge Application

Roof Mounting with LARMF18/36

- 1 - The LARMF roof mounting frame must be installed, flashed and sealed in accordance with the instructions provided with the frame.
- 2 - The LARMF roof mounting frame should be square and level to 1/16" per linear foot (5mm per linear meter) in any direction.
- 3 - Duct must be attached to the roof mounting frame and not to the unit; supply and return plenums must be installed before setting the unit.

Installer's Roof Mounting Frame

Many types of roof frames can be used to install the unit depending upon different roof structures. Items to keep in mind when using the building frame or supports are:

- 1 - The base is fully enclosed and insulated, so an enclosed frame is not required.
- 2 - The frames or supports must be constructed with non-combustible materials and should be square and level to 1/16" per linear foot (5mm per linear meter) in any direction.
- 3 - Frame or supports must be high enough to prevent any form of moisture from entering unit. Recommended minimum frame height is 14" (356mm).
- 4 - Duct must be attached to the roof mounting frame and not to the unit. Supply and return plenums must be installed before setting the unit.

- Units require support along all four sides of unit base. Supports must be constructed of steel or suitably treated wood materials.

NOTE - When installing a unit on a combustibile surface for downflow discharge applications, an LARMF18/36 roof mounting frame is required.

B-Horizontal Discharge Applications

- Units installed in horizontal airflow applications must use an LARMFH18/24 horizontal roof mounting frame. The supply air duct connects to the horizontal supply air opening on the LARMFH18/24. The return air duct connects to the unit horizontal return air opening. Refer to unit dimensions.
- Specified installation clearances must be maintained when installing units. Refer to FIGURE 1.
- Top of support slab should be approximately 4" (102mm) above the finished grade and located so no run-off water from higher ground can collect around the unit.
- Units require support along all four sides of unit base. Supports must be constructed of steel or suitably treated wood materials.

Duct Connection

All exterior ducts, joints and openings in roof or building walls must be insulated and weather-proofed with flashing and sealing compounds in accordance with applicable codes. Any duct passing through an unconditioned space must be insulated.

⚠ CAUTION

In downflow applications, do not drill or punch holes in base of unit. Leaking in roof may occur if unit base is punctured.

Rigging Unit for Lifting

Rig unit for lifting by attaching four cables to holes in unit base rail. See FIGURE 2.

- Detach wooden base protection before rigging.
- Connect rigging to the unit base using both holes in each corner.
- All panels must be in place for rigging.
- Place field-provided H-style pick in place just above top edge of unit. Frame must be of adequate strength and length. (H-style pick prevents damage to unit.)

RIGGING

Unit	*Weight	
	Lbs.	Kg.
LHT/LDT156	2917	1323
LHT/LDT180, 240	2988	1355

*Maximum weight with all available factory-installed accessories.

LIFTING POINT SHOULD BE DIRECTLY ABOVE CENTER OF GRAVITY

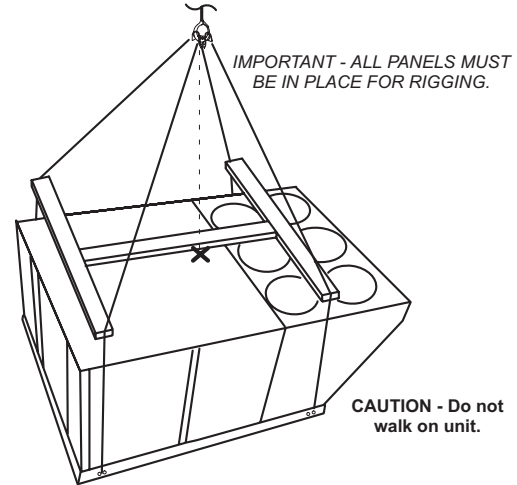

FIGURE 2

Condensate Drains

Remove cap and make drain connection to the 1" N.P.T. drain coupling provided on unit. A trap must be installed between drain connection and an open vent for proper condensate removal. See FIGURE 3. It is sometimes acceptable to drain condensate onto the roof or grade; however, a tee should be fitted to the trap to direct condensate downward. The condensate line must be vented. Check local codes concerning condensate disposal. Refer to page 4, page 5 and page 6 for condensate drain location.

NOTE - The drain pan is made with a glass reinforced engineered plastic capable of withstanding typical joint torque but can be damaged with excessive force. Tighten pipe nipple hand tight and turn an additional quarter turn.

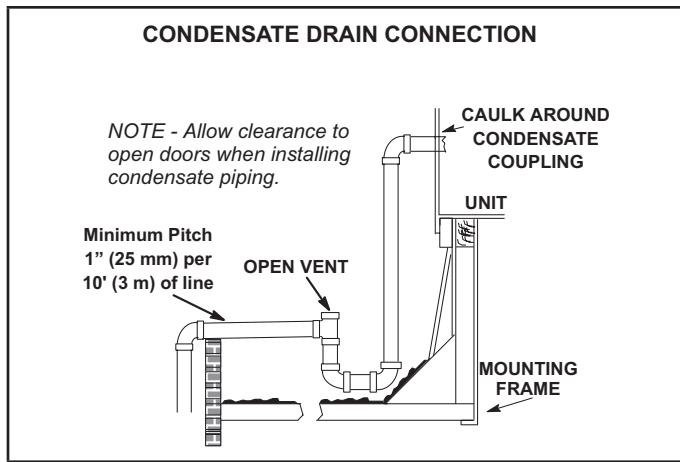

FIGURE 3

Connect Gas Piping

Before connecting piping, check with gas company or authorities having jurisdiction for local code requirements. When installing gas supply piping, length of run from gas meter must be considered in determining pipe size for 0.5" w.c. (.12kPa) maximum pressure drop. Do not use supply pipe smaller than unit gas connection. For natural gas units, operating pressure at the unit gas connection must be a minimum of 4.7" w.c. (1.17kPa) and a maximum of 10.5" (2.60kPa) w.c. For LP/propane gas units, operating pressure at the unit gas connection must be a minimum of 11" w.c. (2.74kPa) and a maximum of 13.5" w.c. (3.36kPa).

When making piping connections a drip leg should be installed on vertical pipe runs to serve as a trap for sediment or condensate. A 1/8" N.P.T. plugged tap is located on gas valve for test gauge connection. Refer to Heating Start-Up section for tap location. A manual main shut-off valve must be installed external to the unit when local codes require the installation of such a valve. Install a ground joint union between the gas control manifold and the main manual shut-off valve. See FIGURE 4 for gas supply piping entering outside the unit. See FIGURE 5 for gas supply entering through bottom of unit.

Compounds used on threaded joints of gas piping shall be resistant to the action of liquefied petroleum gases.

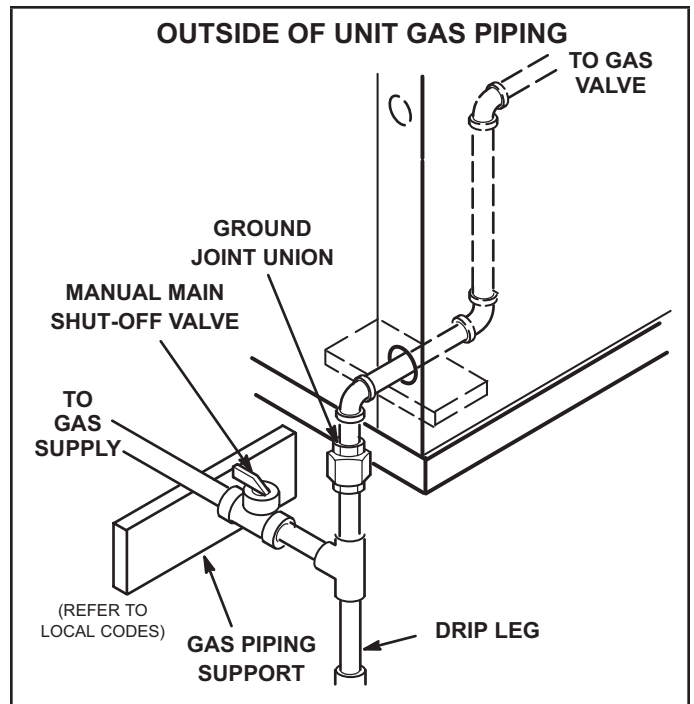

FIGURE 4

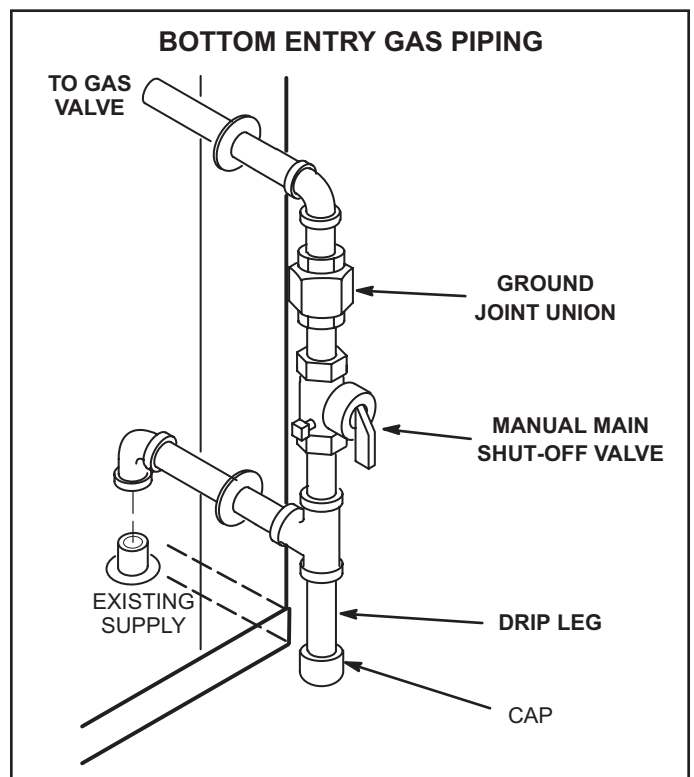

FIGURE 5

Pressure Test Gas Piping

When pressure testing gas lines, the gas valve must be disconnected and isolated. Gas valves can be damaged if subjected to more than 0.5 psig (3.48kPa). See FIGURE 6.

NOTE - Codes may require that manual main shut-off valve and union (furnished by installer) be installed in gas line external to unit. Union must be of the ground joint type.

After all connections have been made, check all piping connections for gas leaks. Also check existing unit gas connections up to the gas valve; loosening may occur during installation. Use a leak detection solution or other preferred means. Do not use matches candles or other sources of ignition to check for gas leaks.

NOTE - In case emergency shut down is required, turn off the main manual shut-off valve and disconnect main power to unit. These devices should be properly labeled by the installer.

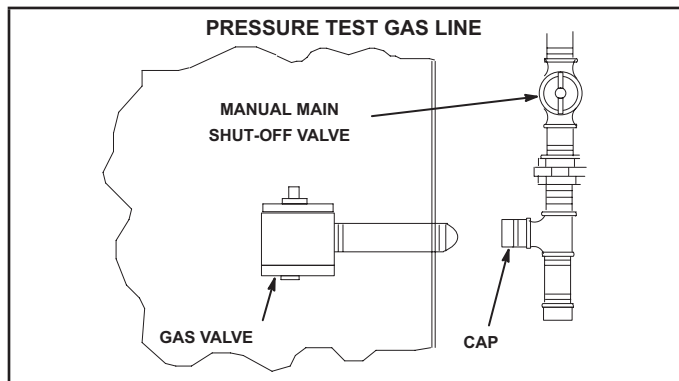

FIGURE 6

CAUTION

Some soaps used for leak detection are corrosive to certain metals. Carefully rinse piping thoroughly after leak test has been completed. Do not use matches, candles, flame or other sources of ignition to check for gas leaks.

WARNING



Danger of explosion. Can cause injury or product or property damage. Do not use matches, candles, flame or other sources of ignition to check for leaks.

Electrical Connections - Power Supply

A-Wiring

Route field wiring in conduit between bottom power entry and disconnect. See FIGURE 7. This does not supersede local codes or authorities having jurisdiction.

Do not apply power or close disconnect switch until installation is complete. Refer to start-up directions. Refer closely to unit wiring diagram.

Refer to unit nameplate for minimum circuit ampacity and maximum fuse size.

- 1 - Units are factory-wired for 240/460/575 volt supply. For 208V supply, remove the insulated terminal cover from the 208V terminal on the control transformer. Move the wire from the transformer 240V terminal to the 208V terminal. Place the insulated terminal cover on the unused 240V terminal.
- 2 - Route power through the bottom power entry area and connect to line side of unit disconnect, circuit breaker or terminal block. See unit wiring diagram.
- 3 - Units With Optional 120v GFCI Outlet

Route and connect separate 120v wiring to GFCI outlets which do not have factory-installed wiring. Route field wiring in conduit between bottom power entry and GFCI. See FIGURE 7.

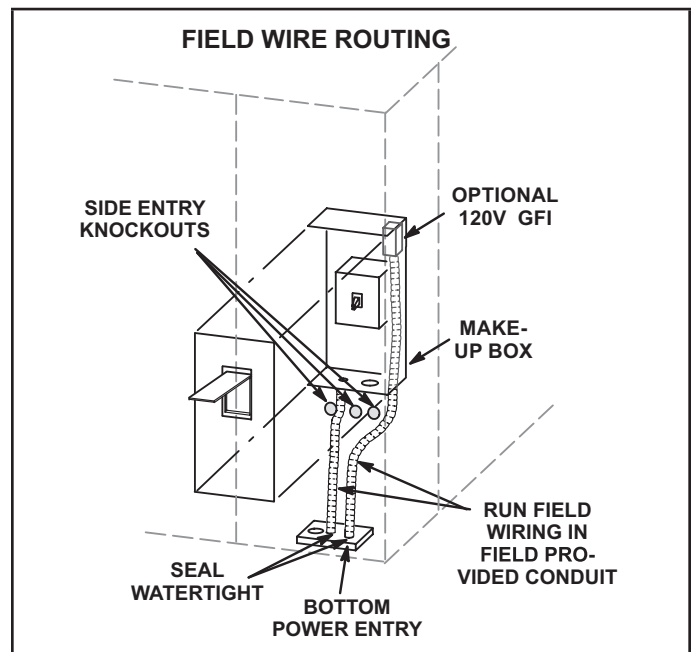

FIGURE 7

B-Unbalanced Three-Phase Voltage

Units equipped with an inverter (VFD) are designed to operate on balanced, three-phase power. Operating units on unbalanced three-phase power will reduce the reliability of all electrical components in the unit. Unbalanced power is a result of the power delivery system supplied by the local utility company.

Factory-installed inverters are sized to drive blower motors with an equivalent current rating using balanced three-phase power. When unbalanced three-phase power is supplied; the installer must replace the existing factory-installed inverter with an inverter that has a higher current rating to allow for the imbalance. Use TABLE 1 to determine the appropriate replacement inverter.

**TABLE 1
INVERTER UP-SIZING**

Factory-Installed Inverter HP	Replacement Inverter HP
3	7-1/2
5	10
7.5	15
10	20

Electrical Connections - Control Wiring

Connect either a thermostat, room/zone sensor, or direct digital controller; one of the three are required for unit function. Refer to the literature provided with each device and the following information.

NOTE - Optional wireless sensors are available for use with this unit.

A-Thermostat Location

Room thermostat mounts vertically on a standard 2" X 4" handy box or on any non-conductive flat surface.

Locate thermostat approximately 5 feet (1524mm) above the floor in an area with good air circulation at average temperature. Avoid locating the room thermostat where it might be affected by:

- drafts or dead spots behind doors and in corners
- hot or cold air from ducts
- radiant heat from sun or appliances
- concealed pipes and chimneys

B-Wire Routing

Route thermostat cable or wires from subbase through knockout provided in unit. Use 18 AWG wire for all applications using remotely installed electro-mechanical and electronic thermostats.

On hot gas reheat units, route wires from RH sensor or remote switch through knockout provided in unit. For sensor installations, use 22AWG stranded, two twisted pairs, individually shielded, 100% aluminum shield with drain wire and Teflon jacket.

IMPORTANT - Unless field thermostat wires are rated for maximum unit voltage, they must be routed away from line voltage wiring.

C-Wire Connections

The Unit Controller will operate the unit from a thermostat or zone sensor based on the System Mode. The default System Mode is the thermostat mode. Refer to the Unit Controller Setup Guide to change the System Mode. Use the mobile service app menu and select:

SETTINGS > INSTALL

NOTE - Unit Controller is capable of up to four stages of cooling in network control mode.

1 - Default Thermostat Mode

The Unit Controller will operate two stages of heating and cooling based on thermostat demands. Install thermostat assembly in accordance with instructions provided with thermostat. See FIGURE 8 for field wiring and refer to wiring diagrams on unit.

IMPORTANT - Terminal connections at the wall plate or subbase must be made securely. Loose control wire connections may result in intermittent operation.

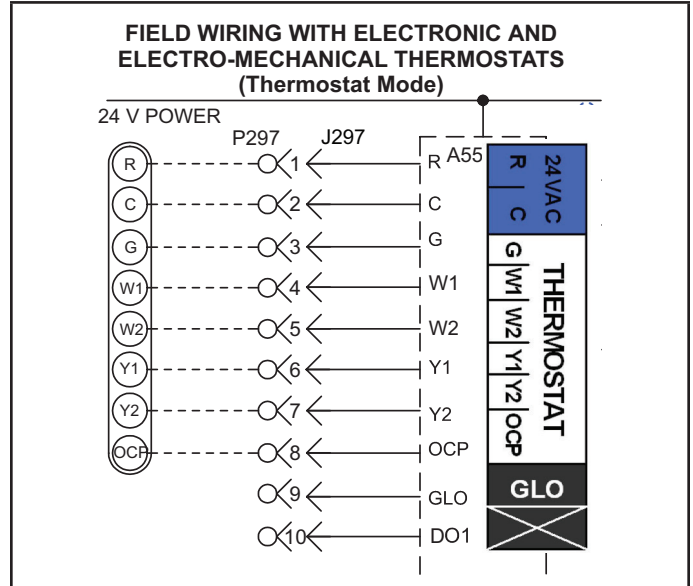

FIGURE 8

2 - Zone Sensor Mode

The Unit Controller will operate heating and cooling based on the Unit Controller internal setpoints and the temperature from the A2 zone sensor. An optional Network Control Panel (NCP) can also be used to provide setpoints. A thermostat or return air sensor can be used as a back-up mode. Make zone sensor wiring connections as shown in FIGURE 9.

NOTE - Install sensor and make communication wiring connections as shown in literature provided with sensor.

C-Hot Gas Reheat Units Only

- 1 - Install humidity sensor in accordance with instructions provided with sensor. A DDC input may be used to initiate dehumidification instead of a sensor.
- 2 - Make wiring connections as shown in FIGURE 8 for Thermostat Mode and FIGURE 9 for Zone Sensor Mode. In addition, connect either a humidity sensor or a dehumidification input. See FIGURE 10 or FIGURE 11 for humidity sensor wiring and FIGURE 12 for dehumidification input wiring.

Humidity Sensor Cable Applications

Wire runs of 50 feet (mm) or less:

Use two separate shielded cables containing 20AWG minimum, twisted pair conductors with overall shield. Belden type 8762 or 88760 (plenum) or equivalent. Connect both cable shield drain wires to TB1-7 as shown in FIGURE 10.

Wire runs of 150 feet (mm) or less:

Use two separate shielded cables containing 18AWG minimum, twisted pair conductors with overall shield. Belden type 8760 or 88760 (plenum) or equivalent. Connect both cable shield drain wires to TB1-7 as shown in FIGURE 10.

Wire runs over 150 feet (mm):

Use a local, isolated 24VAC transformer such as Lennox cat #18M13 (20VA minimum) to supply power to RH sensor as shown in FIGURE 11. Use two shielded cables containing 20AWG minimum, twisted pair conductors with overall shield. Belden type 8762 or 88760 (plenum) or equivalent.

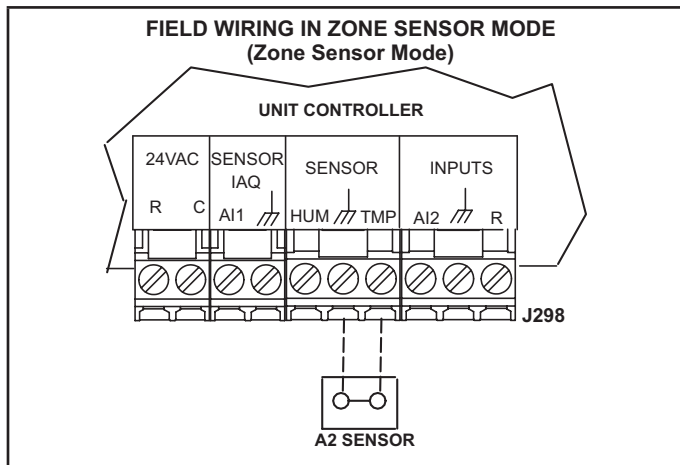

FIGURE 9

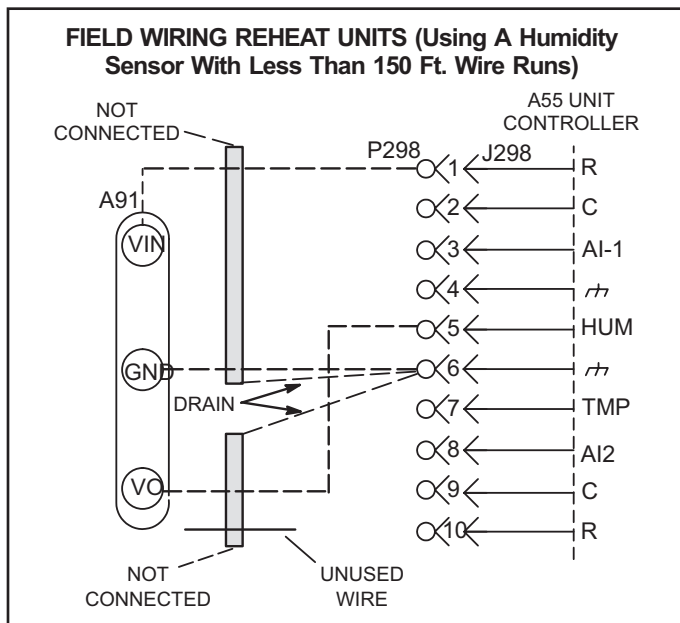

FIGURE 10

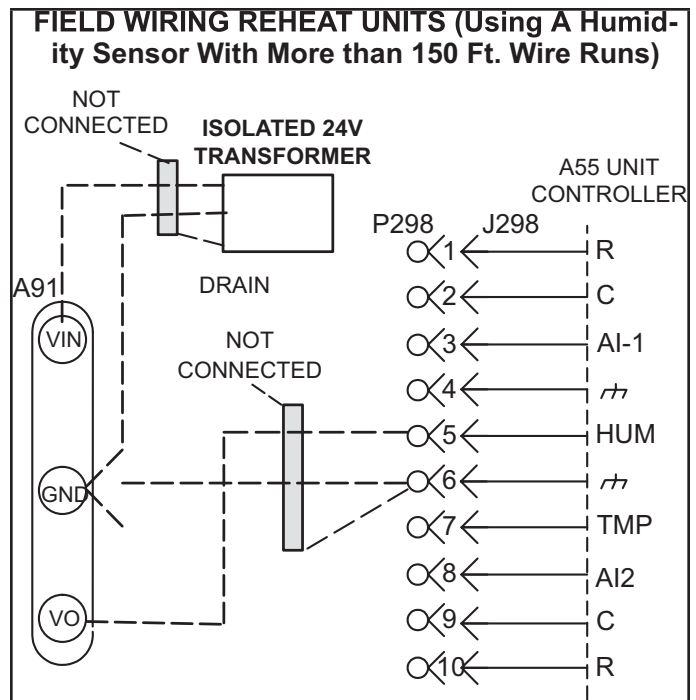
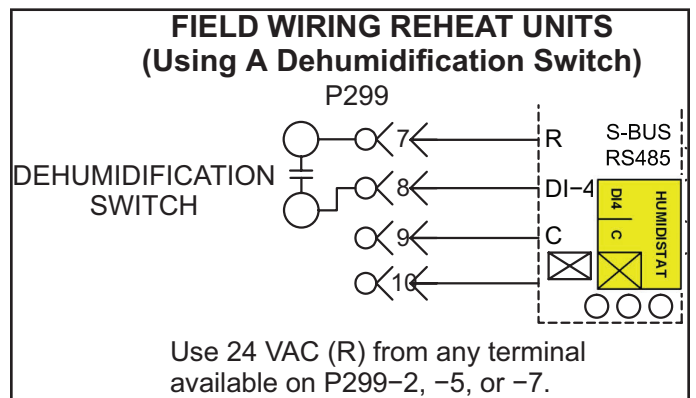

FIGURE 11



Use 24 VAC (R) from any terminal available on P299-2, -5, or -7.

FIGURE 12

Mobile Service App

Setup and configure each rooftop unit using the mobile service app (Android or iOS devices supported).

A-Mobile Device Requirements

- Bluetooth connection.
- Android hardware requires 2GB RAM and a 2Ghz core processor. Tablets are supported.
- The app is available for both iOS 11.0 or higher (App Store) and Android 9.0 or higher (Google Play).

B-Download the App

Use your mobile device to scan the QR code from the cover page and download the mobile service app to your mobile device.

C-Pair the App to the Unit Controller

- 1 - Apply power to the unit and wait until the Unit Controller has booted-up (approximately two minutes).
- 2 - Press and hold the pair button for five seconds. See FIGURE 14.
- 3 - The unit (or list of units) will appear; select the appropriate unit. When the app code matches the four-character code on the Unit Controller display, the unit is paired (within 10 seconds). Note the following:
 - The app will list the units by signal strength; the RTU name will be displayed.
 - Once paired, the RTU name, model number, serial number and firmware version will be displayed.

Please refer to the manufacturer's website for additional technical information and self-help support.

D-App Menus

See FIGURE 13 for the menu overview. Follow the app prompts in the Install, Network Integration, and Test and Balance menus. Verify the app is setup properly for the unit application (including the date and time). Refer to FIGURE 15, FIGURE 16, and FIGURE 17.

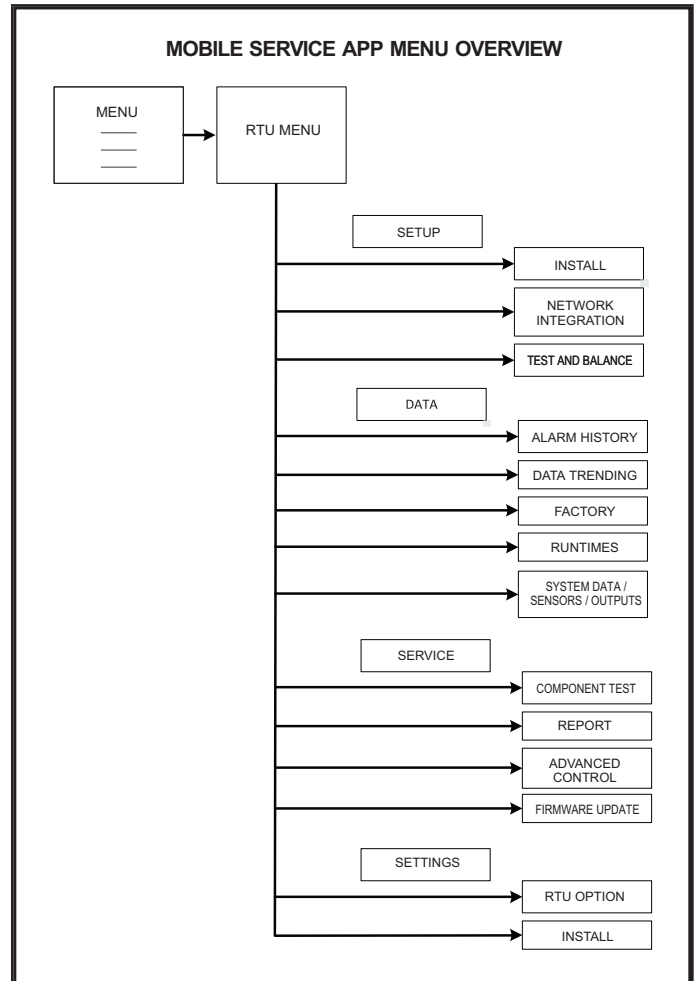

FIGURE 13

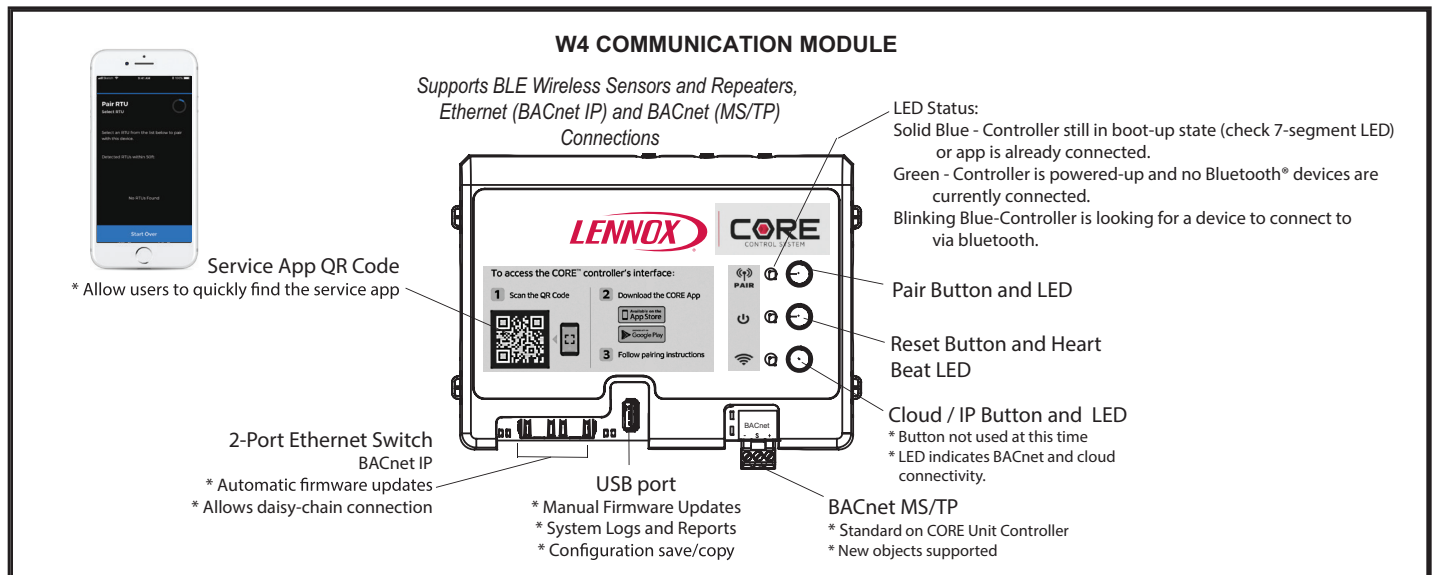

FIGURE 14

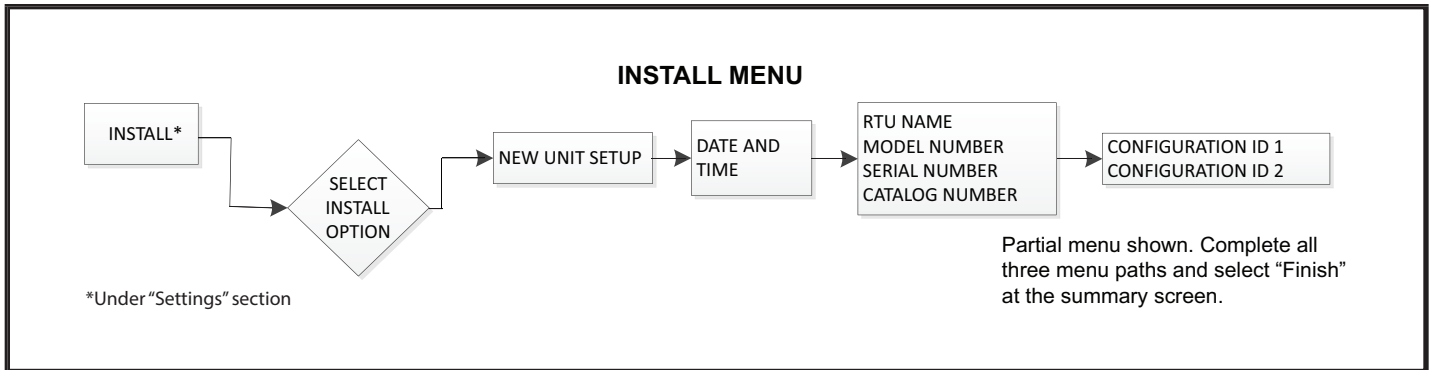

FIGURE 15

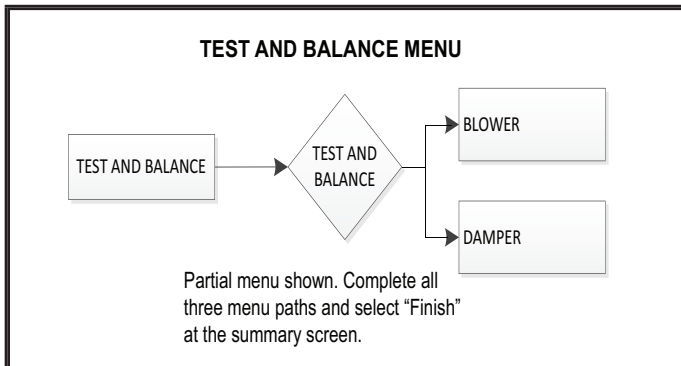

FIGURE 16

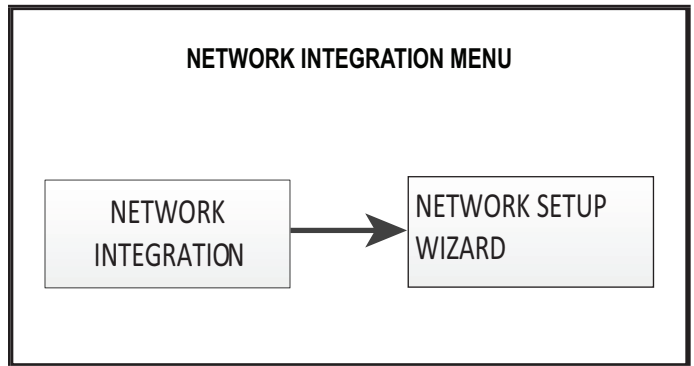

FIGURE 17

E-Unit Controller Components

See FIGURE 18 for Unit Controller components. See FIGURE 18 and TABLE 2 for pushbutton and LED functions.

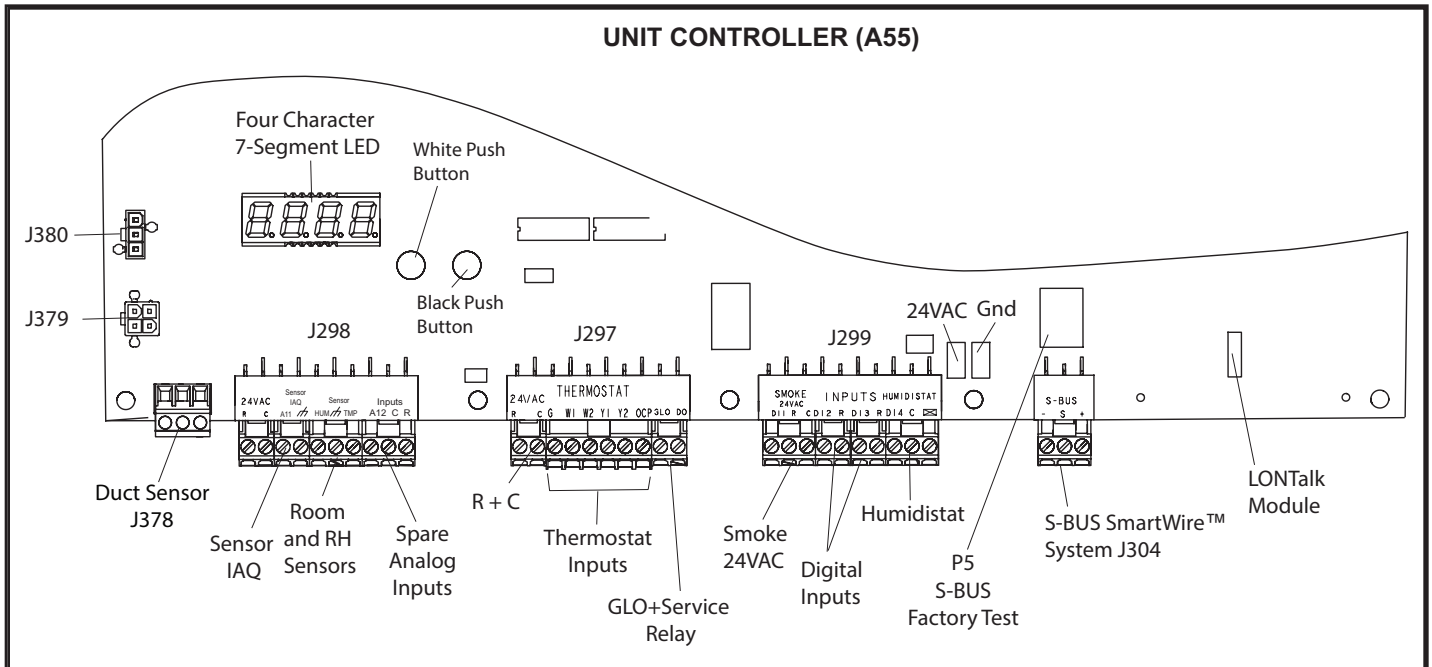

FIGURE 18

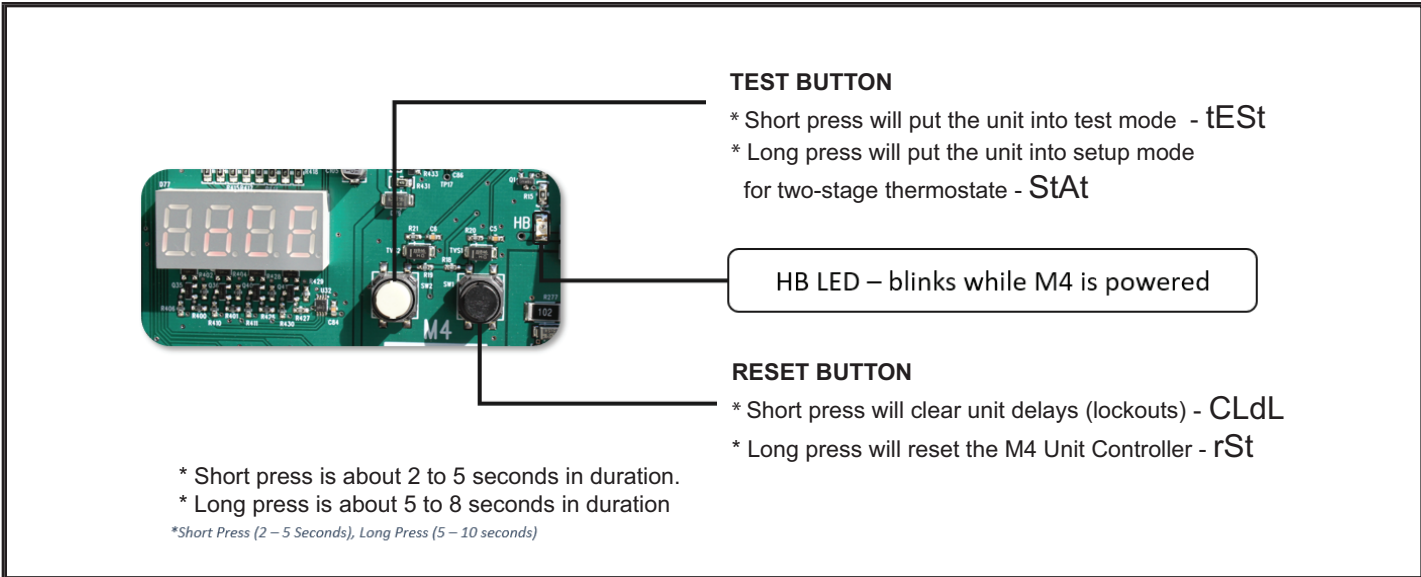

FIGURE 19

TABLE 2
UNIT CONTROLLER PUSHBUTTON CODES

Code	Cause	Action
CLdL	Black Button: Short Press	Clear Delays
rSt	Black Button: Long Press	Reset
tEst	White Button: Short Press	TSTAT Test
StAt	White Button: Long Press (In Pre-Install state)	TSTAT Override
tEst	White Button: Long Press (NOT in Pre-Install State)	TSTAT Test

Short Press : 2 to 5 seconds.
 Long Press : 5 to 8 seconds.

Blower Operation and Adjustments

Supply Air Staged Units - The blower rotation will always be correct on units equipped with an inverter. Checking blower rotation is not a valid method of determining voltage phasing for incoming power.

Supply Air Staged Units and Units Equipped With Optional Voltage or Phase Detection - The Unit Controller checks the incoming power during start-up. If the voltage or phase is incorrect, the Unit Controller will display an alarm and the unit will not start.

A-Blower Operation

Refer to the Unit Controller Setup Guide to energize blower. Use this mobile service app menu:

SERVICE > TEST > BLOWER

Instructions provided with the thermostat may also be used to initiate blower only (G) demand. Unit will cycle on thermostat demand. The following steps apply to applications using a typical electro-mechanical thermostat.

- 1 - Blower operation is manually set at the thermostat subbase fan switch. With fan switch in ON position, blowers will operate continuously.
- 2 - With fan switch in AUTO position, the blowers will cycle with demand. Blowers and entire unit will be off when system switch is in OFF position.

⚠ IMPORTANT

Three Phase Scroll Compressor Voltage Phasing

Three phase scroll compressors must be phased sequentially to ensure correct compressor and blower* rotation and operation. Compressor and blower are wired in phase at the factory. Power wires are color-coded as follows: line 1-red, line 2-yellow, line 3-blue.

- 1- Observe suction and discharge pressures and blower* rotation on unit start-up.
- 2- Suction pressure must drop, discharge pressure must rise, and blower* rotation must match rotation marking.

If pressure differential is not observed or blower* rotation is not correct:

- 3- Disconnect all remote electrical power supplies.
- 4- Reverse any two field-installed wires connected to the line side of S48 disconnect or TB13 terminal strip. Do not reverse wires at blower contactor.
- 5- Make sure the connections are tight.

Discharge and suction pressures should operate at their normal start-up ranges.

*Supply air VFD motors should rotate in the correct direction; verify scroll compressor rotation separately. Contact technical support if the VFD blower is rotating incorrectly.

⚠ WARNING

- 1- Make sure that unit is installed in accordance with the installation instructions and applicable codes.
- 2- Inspect all electrical wiring, both field and factory-installed, for loose connections. Tighten as required.
- 3- Check to ensure that refrigerant lines do not rub against the cabinet or against other refrigerant lines.
- 4- Check voltage at disconnect switch. Voltage must be within range listed on nameplate. If not, consult power company and have voltage condition corrected before starting unit.
- 5- Make sure filters are new and in place before start-up.

B-Blower Access

- 1 - Disconnect jack/plug connector to blower motor. Also disconnect jack/plug connector heating limit switches on gas units.
- 2 - Remove screws on either side of blower assembly sliding base. See FIGURE 21.
- 3 - Pull base toward outside of unit.

C-Determining Unit CFM

IMPORTANT - Multi-staged supply air units are factory-set to run the blower at full speed when there is a blower (G) demand without a heating or cooling demand. Refer to the field-provided, design specified CFM for all modes of operation. Use the following procedure to adjust motor pulley to deliver the highest CFM called for in the design spec. See Inverter Start-Up section to set blower CFM for all modes once the motor pulley is set.

- 1 - The following measurements must be made with a dry indoor coil. Run blower (G demand) without a cooling demand. Measure the indoor blower shaft RPM. Air filters must be in place when measurements are taken.
- 2 - With all access panels in place, measure static pressure external to unit (from supply to return). Blower performance data is based on static pressure readings taken in locations shown in FIGURE 20.

NOTE - *Static pressure readings can vary if not taken where shown.*

- 3 - Referring to the blower tables, use static pressure and RPM readings to determine unit CFM. Use the accessory air resistance table when installing units with any of the optional accessories listed.

4 - The blower RPM can be adjusted at the motor pulley. Loosen Allen screw and turn adjustable pulley clockwise to increase CFM. Turn counterclockwise to decrease CFM. See FIGURE 21. Do not exceed minimum and maximum number of pulley turns as shown in TABLE 3.

TABLE 3
MINIMUM AND MAXIMUM PULLEY ADJUSTMENT

Belt	Min. Turns Open	Max. Turns Open
A Section	No minimum	5
B Section	1*	6

*No minimum number of turns open when B belt is used on pulleys 6" O.D. or larger.

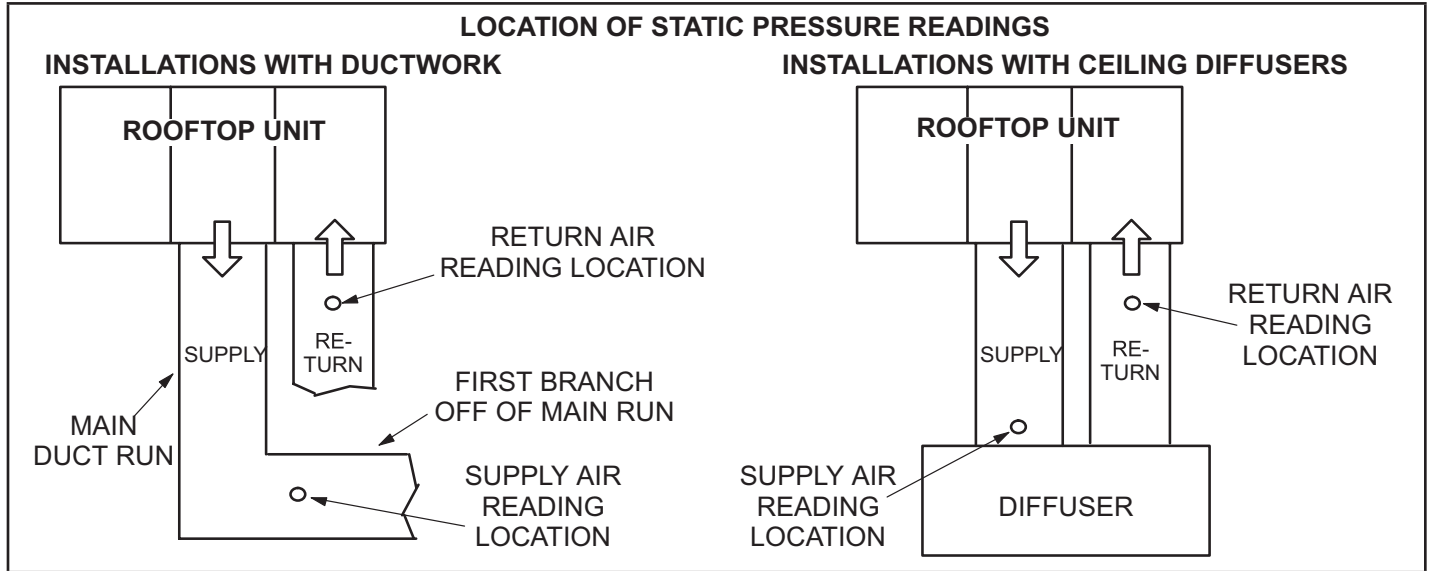

FIGURE 20

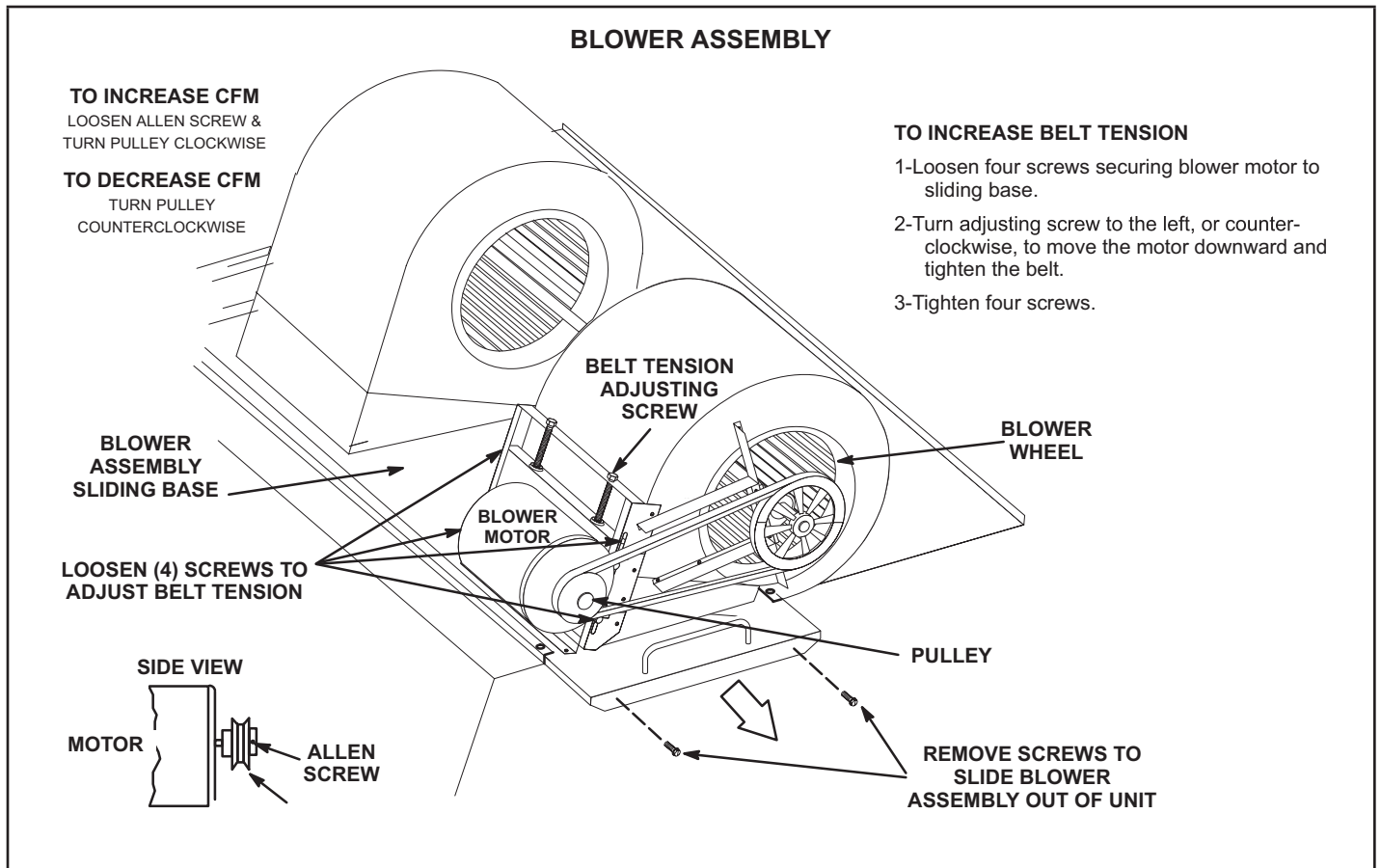

FIGURE 21

D-Blower Belt Adjustment

Maximum life and wear can be obtained from belts only if proper pulley alignment and belt tension are maintained. Tension new belts after a 24-48 hour period of operation. This will allow belt to stretch and seat into pulley grooves. Make sure blower and motor pulley are aligned. See FIGURE 22.

- 1 - Loosen four screws securing blower motor to sliding base. See FIGURE 21.
- 2 - To increase belt tension -
Turn belt tension adjusting screw to the left, or counterclockwise, to tighten the belt. This increases the distance between the blower motor and the blower housing.
To loosen belt tension -
Turn the adjusting screw to the right, or clockwise to loosen belt tension.
- 3 - Tighten four screws securing blower motor to sliding base once adjustments have been made.

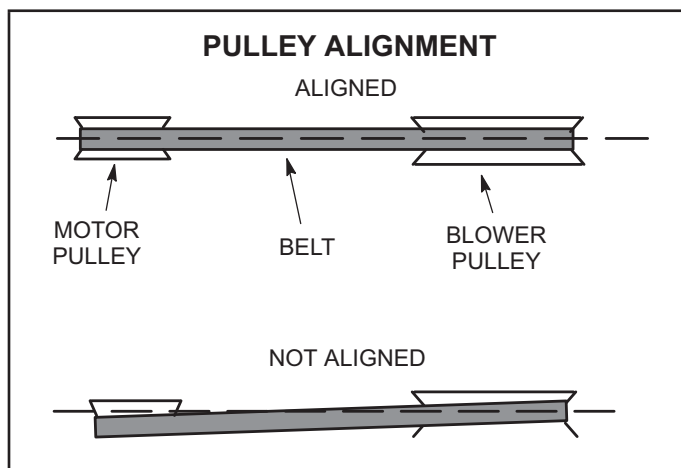

FIGURE 22

E-Check Belt Tension

Overtensioning belts shortens belt and bearing life. Check belt tension as follows:

- 1 - Measure span length X. See FIGURE 23.
- 2 - Apply perpendicular force to center of span (X) with enough pressure to deflect belt $1/64$ " for every inch of span length or 1.5mm per 100mm of span length.
Example: Deflection distance of a 40" span would be $40/64$ " or $5/8$ ".
Example: Deflection distance of a 400mm span would be 6mm.
- 3 - Measure belt deflection force. For a used belt, the deflection force should be 5 lbs. (35kPa). A new belt deflection force should be 7 lbs. (48kPa).
A force below these values indicates an undertensioned belt. A force above these values indicates an overtensioned belt.

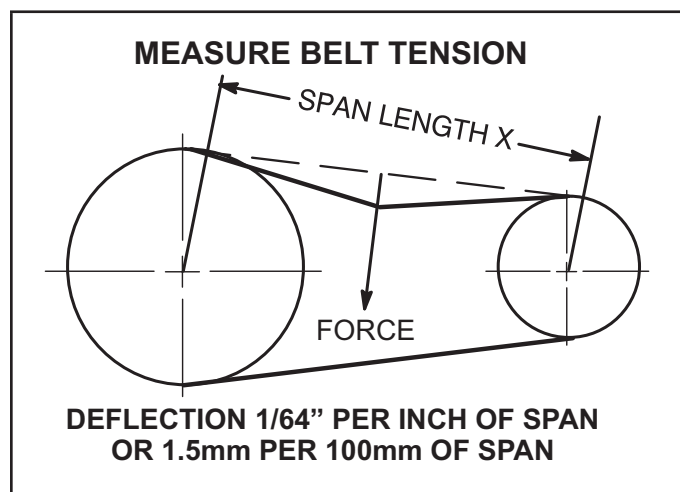

FIGURE 23

F-Field-Furnished Blower Drives

For field-furnished blower drives, use page 20 or page 21 to determine BHP and RPM required. Reference TABLE 4 to determine the manufacturer's model number.

BLOWER DATA

BLOWER TABLE INCLUDES RESISTANCE FOR BASE UNIT ONLY WITH DRY INDOOR COIL & AIR FILTERS IN PLACE.

- 1 - Wet indoor coil air resistance of selected unit. 2 - Any factory installed options air resistance (electric heat, economizer, etc.) 3 - Any field installed accessories air resistance (electric heat, duct resistance, diffuser, etc.)

Then determine from blower table blower motor output and drive required. See page 21 for wet coil and option/accessory air resistance data.

See page 16 for factory installed drive kit specifications.

MINIMUM AIR VOLUME REQUIRED FOR DIFFERENT GAS HEAT SIZES:

Low (L), Standard (S) and Medium Heat (M) - 4500 cfm minimum. High Heat (H) - 5125 cfm minimum.

MINIMUM AIR VOLUME REQUIRED FOR USE WITH OPTIONAL ELECTRIC HEAT:

LHT units require 6000cfm minimum air with electric heat.

Air Volume cfm	TOTAL STATIC PRESSURE - Inches Water Gauge (Pa)																									
	0.20		0.40		0.60		0.80		1.00		1.20		1.40		1.60		1.80		2.00		2.20		2.40		2.60	
	RPM	BHP	RPM	BHP	RPM	BHP	RPM	BHP	RPM	BHP	RPM	BHP	RPM	BHP	RPM	BHP	RPM	BHP	RPM	BHP	RPM	BHP	RPM	BHP	RPM	BHP
2750	385	0.30	505	0.50	600	0.70	680	0.90	755	1.10	820	1.30	885	1.50	950	1.70	1005	1.90	1060	2.10	1115	2.30	1170	2.50	1225	2.70
3000	395	0.35	515	0.55	610	0.75	685	1.00	760	1.20	825	1.45	885	1.70	950	1.95	1005	2.20	1060	2.45	1115	2.70	1170	2.95	1225	3.20
3250	405	0.40	520	0.60	615	0.85	695	1.10	765	1.30	830	1.60	890	1.85	950	2.10	1005	2.35	1060	2.60	1115	2.85	1170	3.10	1225	3.35
3500	415	0.45	530	0.70	620	0.95	700	1.20	775	1.45	840	1.70	900	2.00	955	2.25	1005	2.50	1060	2.75	1115	3.00	1170	3.25	1225	3.50
3750	425	0.50	540	0.75	630	1.05	710	1.30	780	1.60	845	1.85	905	2.15	960	2.40	1005	2.65	1060	2.90	1115	3.15	1170	3.40	1225	3.65
4000	435	0.55	545	0.85	635	1.10	715	1.40	785	1.70	850	2.00	910	2.30	965	2.55	1005	2.80	1060	3.05	1115	3.30	1170	3.55	1225	3.80
4250	445	0.60	555	0.90	645	1.25	725	1.55	795	1.85	855	2.15	915	2.45	970	2.70	1005	2.95	1060	3.20	1115	3.45	1170	3.70	1225	3.95
4500	455	0.70	565	1.00	655	1.35	730	1.65	800	2.00	865	2.35	925	2.65	980	2.90	1005	3.15	1060	3.40	1115	3.65	1170	3.90	1225	4.15
4750	470	0.75	575	1.10	660	1.45	740	1.80	810	2.15	870	2.50	930	2.85	985	3.10	1005	3.35	1060	3.60	1115	3.85	1170	4.10	1225	4.35
5000	480	0.85	585	1.25	670	1.60	750	1.95	815	2.30	880	2.70	940	3.05	995	3.30	1005	3.55	1060	3.80	1115	4.10	1170	4.35	1225	4.60
5250	495	0.95	595	1.35	680	1.70	755	2.10	825	2.50	890	2.90	945	3.25	1000	3.50	1005	3.75	1060	4.00	1115	4.30	1170	4.55	1225	4.80
5500	505	1.05	605	1.45	690	1.85	765	2.25	835	2.65	895	3.05	955	3.45	1010	3.70	1005	3.95	1060	4.20	1115	4.45	1170	4.70	1225	4.95
5750	520	1.15	615	1.60	700	2.00	775	2.45	840	2.85	905	3.25	960	3.65	1015	3.90	1005	4.15	1060	4.40	1115	4.60	1170	4.85	1225	5.10
6000	530	1.30	630	1.75	710	2.15	785	2.60	850	3.05	910	3.45	970	3.90	1025	4.15	1005	4.35	1060	4.60	1115	4.80	1170	5.05	1225	5.30
6250	545	1.40	640	1.90	720	2.35	795	2.80	860	3.25	920	3.70	975	4.15	1030	4.40	1005	4.60	1060	4.85	1115	5.10	1170	5.30	1225	5.60
6500	560	1.55	650	2.05	730	2.50	805	3.00	870	3.45	930	3.95	985	4.40	1040	4.85	1005	5.10	1060	5.35	1115	5.60	1170	5.80	1225	6.05
6750	570	1.70	665	2.20	745	2.70	815	3.20	880	3.70	940	4.20	995	4.65	1045	5.10	1005	5.40	1060	5.65	1115	5.90	1170	6.10	1225	6.35
7000	585	1.85	675	2.35	755	2.90	825	3.40	890	3.95	950	4.45	1005	4.95	1055	5.40	1005	5.65	1060	5.90	1115	6.15	1170	6.35	1225	6.60
7250	600	2.00	690	2.60	765	3.10	835	3.65	900	4.15	955	4.65	1015	5.25	1065	5.75	1005	5.90	1060	6.15	1115	6.40	1170	6.60	1225	6.85
7500	615	2.20	700	2.75	775	3.30	845	3.85	910	4.45	965	4.95	1020	5.50	1075	6.05	1005	6.15	1060	6.40	1115	6.65	1170	6.85	1225	7.10
7750	630	2.40	715	3.00	790	3.55	855	4.10	920	4.70	975	5.25	1030	5.80	1080	6.35	1005	6.40	1060	6.65	1115	6.90	1170	7.10	1225	7.35
8000	640	2.55	725	3.20	800	3.80	865	4.35	930	4.95	985	5.50	1040	6.10	1090	6.70	1005	6.65	1060	6.90	1115	7.15	1170	7.35	1225	7.60
8250	655	2.80	740	3.40	810	4.00	880	4.65	940	5.25	995	5.85	1050	6.45	1100	7.05	1005	6.90	1060	7.15	1115	7.40	1170	7.60	1225	7.85
8500	670	3.00	750	3.65	825	4.30	890	4.90	950	5.55	1005	6.15	1060	6.80	1110	7.40	1005	7.15	1060	7.40	1115	7.65	1170	7.85	1225	8.10
8750	685	3.25	765	3.90	835	4.55	900	5.20	960	5.85	1015	6.45	1070	7.15	1120	7.75	1005	7.40	1060	7.65	1115	7.90	1170	8.10	1225	8.35
9000	700	3.50	780	4.20	850	4.85	910	5.50	970	6.15	1025	6.80	1080	7.50	1130	8.15	1005	7.65	1060	7.90	1115	8.15	1170	8.40	1225	8.60
9250	715	3.75	790	4.45	860	5.15	925	5.85	985	6.55	1040	7.20	1090	7.85	1140	8.55	1005	7.90	1060	8.15	1115	8.40	1170	8.65	1225	8.85
9500	730	4.00	805	4.75	875	5.45	935	6.15	995	6.90	1050	7.60	1100	8.25	1150	8.95	1005	8.15	1060	8.40	1115	8.65	1170	8.90	1225	9.10
9750	745	4.30	820	5.05	885	5.75	950	6.55	1005	7.20	1060	7.95	1110	8.65	1160	9.40	1005	8.40	1060	8.65	1115	8.90	1170	9.15	1225	9.35
10,000	760	4.60	835	5.40	900	6.15	960	6.85	1015	7.60	1070	8.35	1120	9.05	1170	9.80	1005	8.65	1060	8.90	1115	9.15	1170	9.40	1225	9.60
10,250	775	4.90	845	5.65	910	6.45	970	7.20	1030	8.00	1080	8.75	1135	9.55	1180	10.25	1005	8.90	1060	9.15	1115	9.40	1170	9.65	1225	9.85
10,500	790	5.20	860	6.00	925	6.85	985	7.65	1040	8.40	1095	9.20	1145	10.00	1190	10.70	1005	9.15	1060	9.40	1115	9.65	1170	9.90	1225	10.10
10,750	805	5.55	875	6.40	940	7.25	1000	8.05	1055	8.85	1105	9.65	1155	10.45	1200	11.20	1005	9.40	1060	9.65	1115	9.90	1170	10.15	1225	10.35
11,000	820	5.90	890	6.80	950	7.60	1010	8.45	1065	9.30	1115	10.05	1165	10.90	1210	11.85	1005	9.65	1060	9.90	1115	10.15	1170	10.35	1225	10.60

BLOWER DATA

FACTORY INSTALLED BELT DRIVE KIT SPECIFICATIONS

Motor Efficiency	Nominal hp	Maximum hp	Drive Kit Number	RPM Range
Standard	3	3.45	1	535 - 725
Standard	3	3.45	2	710 - 965
Standard	5	5.75	3	685 - 856
Standard	5	5.75	4	850 - 1045
Standard	5	5.75	5	945 - 1185
Standard	7.5	8.63	6	850 - 1045
Standard	7.5	8.63	7	945 - 1185
Standard	7.5	8.63	8	1045 - 1285
Standard	10	11.50	7	945 - 1185
Standard	10	11.50	10	1045 - 1285
Standard	10	11.50	11	1105-1330

NOTE - Using total air volume and system static pressure requirements determine from blower performance tables rpm and motor output required. Maximum usable output of motors furnished are shown. In Canada, nominal motor output is also maximum usable motor output. If motors of comparable output are used, be sure to keep within the service factor limitations outlined on the motor nameplate.

NOTE - All units are limited to a motor service factor of 1.0.

FACTORY INSTALLED OPTIONS/FIELD INSTALLED ACCESSORY AIR RESISTANCE

Air Volum cfm	Wet Indoor Coil	Reheat Coil	Gas Heat Exchanger			Electric Heat	Econo- mizer	Filters		Horizontal Roof Curb
			Low/Std. Heat	Medium Heat	High Heat					156-240
			in. w.g.	in. w.g.	in. w.g.			MERV 8	MERV 13	in. w.g.
2750	0.02	0.01	0.02	0.04	0.05	---	---	0.01	0.03	0.03
3000	0.02	0.01	0.03	0.04	0.05	---	---	0.01	0.03	0.04
3250	0.03	0.01	0.03	0.05	0.06	---	---	0.01	0.04	0.04
3500	0.03	0.02	0.03	0.05	0.06	---	---	0.01	0.04	0.05
3750	0.03	0.02	0.04	0.06	0.07	---	---	0.01	0.04	0.05
4000	0.04	0.02	0.04	0.06	0.07	---	---	0.04	0.06	0.06
4250	0.04	0.02	0.04	0.06	0.08	---	---	0.04	0.06	0.07
4500	0.05	0.02	0.05	0.07	0.09	---	---	0.04	0.07	0.07
4750	0.05	0.02	0.05	0.08	0.1	---	---	0.04	0.07	0.08
5000	0.05	0.02	0.05	0.09	0.11	---	---	0.05	0.07	0.08
5250	0.06	0.03	0.06	0.1	0.12	---	---	0.05	0.07	0.09
5500	0.07	0.03	0.06	0.1	0.13	---	---	0.05	0.07	0.1
5750	0.07	0.03	0.06	0.11	0.14	---	---	0.05	0.08	0.11
6000	0.08	0.03	0.07	0.12	0.15	0.01	---	0.05	0.08	0.11
6250	0.08	0.03	0.07	0.12	0.16	0.01	0.01	0.05	0.08	0.12
6500	0.09	0.04	0.08	0.13	0.17	0.01	0.02	0.05	0.08	0.13
6750	0.1	0.04	0.08	0.14	0.18	0.01	0.03	0.05	0.08	0.14
7000	0.1	0.04	0.09	0.15	0.19	0.01	0.04	0.06	0.08	0.15
7250	0.11	0.04	0.09	0.16	0.2	0.01	0.05	0.06	0.09	0.16
7500	0.12	0.05	0.1	0.17	0.21	0.01	0.06	0.06	0.09	0.17
8000	0.13	0.05	0.11	0.19	0.24	0.02	0.09	0.06	0.09	0.19
8500	0.15	0.05	0.12	0.2	0.26	0.02	0.11	0.06	0.09	0.21
9000	0.16	0.06	0.13	0.23	0.29	0.04	0.14	0.07	0.1	0.24
9500	0.18	0.07	0.14	0.25	0.32	0.05	0.16	0.07	0.1	0.26
10,000	0.2	0.07	0.16	0.27	0.35	0.06	0.19	0.07	0.11	0.29
10,500	0.22	0.08	0.17	0.3	0.38	0.09	0.22	0.07	0.11	0.31
11,000	0.24	0.08	0.18	0.31	0.4	0.11	0.25	0.08	0.11	0.34

**TABLE 4
MANUFACTURER'S NUMBERS**

Drive No.	H.P.	DRIVE COMPONENTS												
		RPM		ADJUSTABLE SHEAVE		FIXED SHEAVE		BELTS (STD.)		BELTS (WITH TENSIONER)		SPLIT BUSHING		
		Min	Max	Supplier No.	OEM Part No.	Supplier No.	OEM Part No.	Supplier No.	OEM Part No.	Supplier No.	OEM Part No.	Supplier No.	OEM Part No.	
1	3	535	725	1VP40x7/8	79J0301	BK95 x 1-3/16	105617-02	BX59	59A5001	BX60	100245-10	N/A	N/A	N/A
2	3	710	965	1VP40x7/8	79J0301	BK72 x 1-3/16	105617-01	BX55	63K0501	BX57	78L5301	N/A	N/A	N/A
3	5	685	865	1VP50x1-1/8	P-8-1977	BK100 x 1-3/16	105617-03	BX61	93J9801	5VX660	100245-20	N/A	N/A	N/A
4	5	850	1045	1VP65x1-1/8	100239-03	BK110H	100788-06	BX65	100245-08	BX66	97J5901	H-1-3/16	105616-02	105616-02
5	5	945	1185	1VP60x1-1/8	41C1301	BK90H x 1-7/16	100788-04	BX61	93J9801	BX62	57A7701	H-1-3/16	105616-02	105616-02
6	7.5	850	1045	1VP65x1-3/8	78M7101	BK110H	100788-06	BX66	97J5901	BX67	100245-09	H-1-3/16	105616-02	105616-02
7	7.5 & 10	945	1185	1VP60x1-3/8	78L5501	BK90H x 1-7/16	100788-04	BX62	57A7701	BX64	97J5801	H-1-3/16	105616-02	105616-02
8	7.5	1045	1285	1VP65x1-3/8	78M7101	BK90H x 1-7/16	100788-04	BX64	97J5801	5VX670	100245-21	H-1-3/16	105616-02	105616-02
10	10	1045	1285	1VP65x1-3/8	78M7101	1B5V86	78M8301	5VX660	100245-20	5VX670	100245-21	B-1-3/16	105616-01	105616-01
11	10	1105	1330	1VP71 X 1-3/8	100239-06	1B5V90	100240-02	5VX680	100245-35	5VX660	100245-20	B-1-3/16	105616-01	105616-01

Refrigerant Leak Detection System

A-System Test

- 1 - Initiate Refrigerant Leak Detection System Test by using the following mobile service app menu path:

RTU MENU > COMPONENT TEST > LEAK DETECTION > START TEST

- 2 - Ensure that indoor blower, outdoor fan, and combustion air blower (LDT only) are energized.

Cooling Start-Up

IMPORTANT - The crankcase heater must be energized for 24 hours before attempting to start compressor. Set thermostat so there is no demand to prevent compressors from cycling. Apply power to unit.

NOTE - These units must not be used as a "construction heater" at any time during any phase of construction. Very low return air temperatures, harmful vapors and misplacement of the filters will damage the unit and its efficiency. Additionally, a unit which will be subject to cold temperatures when not in operation must have a vapor barrier installed to seal the duct connections. Failure to protect the unit from moisture laden air or harmful vapors (generated from the construction process and temporary combustion heating equipment) will cause corrosive condensation within the unit. Failure to properly protect the unit in this situation will cause electrical and electronic component failure and could affect the unit warranty status.

A-Preliminary Checks

- 1 - Make sure that unit is installed in accordance with the installation instructions and applicable codes.
- 2 - Inspect all electrical wiring, both field and factory-installed, for loose connections. Tighten as required.
- 3 - Check to ensure that refrigerant lines do not rub against the cabinet or against other refrigerant lines.
- 4 - Check voltage at disconnect switch. Voltage must be within range listed on nameplate. If not, consult power company and have voltage condition corrected before starting unit.
- 5 - Make sure filters are in place before start-up.

B-Start-Up

Supply Air Staged Blower - Refer to the Multi-Staged Air Volume Start-Up section.

- 1 - Initiate first and second stage cooling demands using this mobile service app menu path:

SERVICE > TEST > COOLING > COOL3

Instructions provided with the thermostat may also be used to initiate cooling.

- 2 - First-stage thermostat demand will energize indoor blower in Low Cooling CFM. Second-stage thermostat demand will energize indoor blower in High Cooling CFM. Both demands energize compressor 1. The remaining compressors will be energized to modulate the discharge air temperature.
- 3 - Units contain two refrigerant circuits or systems. See FIGURE 24.
- 4 - Each refrigerant circuit is separately charged with R454B refrigerant. See unit rating plate for correct amount of charge.
- 5 - Refer to the Refrigerant Check and Charge section to check refrigerant charge.

C-R454B Refrigerant

Units charged with R454B refrigerant operate at lower pressures than R410A. The expansion valve and liquid line dryer provided with the unit are approved for use with R454B and R410A.

R454B refrigerant is stored in a gray cylinder.

CAUTION

Mineral oils are not compatible with R454B. If oil must be added, it must be a polyol ester oil.

Manifold gauge sets used with systems charged with R454B refrigerant must be capable of handling various system operating pressures. The gauges should be rated for use with pressures of 0-800 on the high side and a low side of 30" vacuum to 250 psi with dampened speed to 500 psi. Gauge hoses must be rated for use at up to 800 psi of pressure with a 4000 psi burst rating.

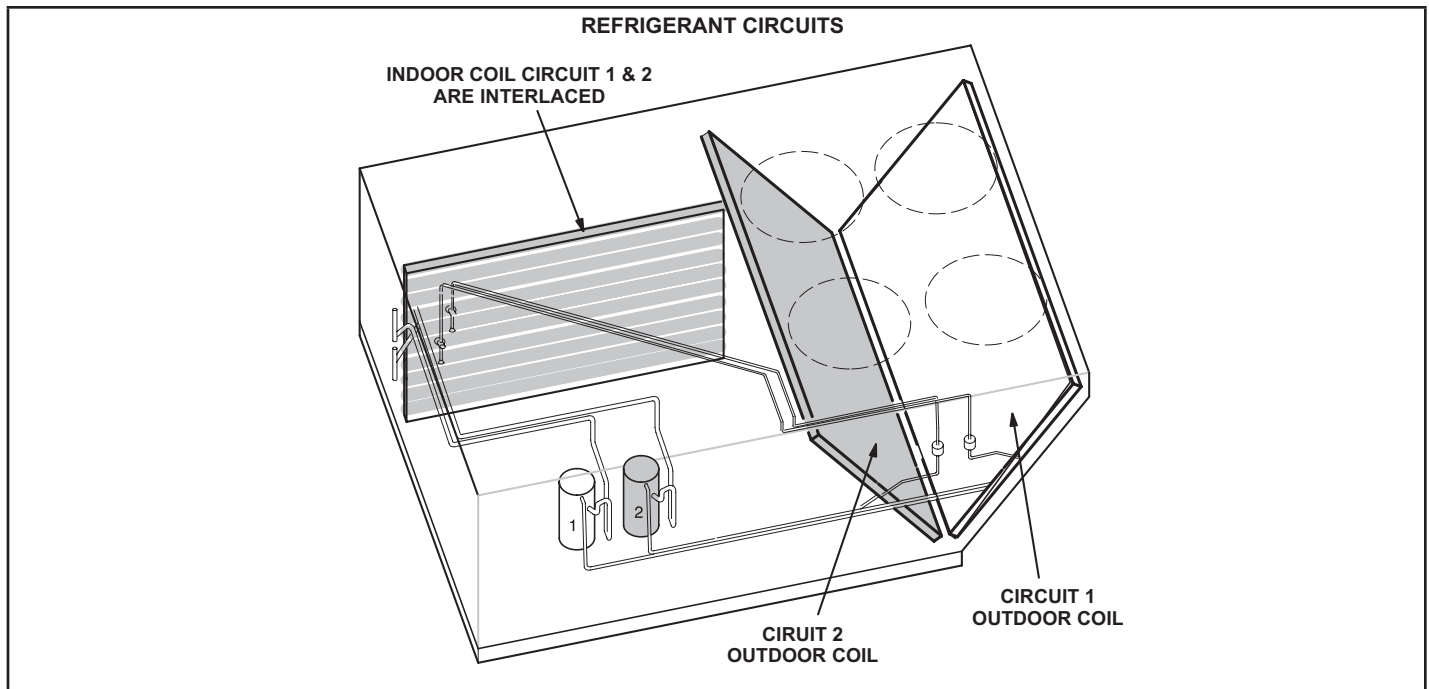

FIGURE 24

D-Refrigerant Charge and Check - Fin/Tube Coil

WARNING - Do not exceed nameplate charge under any condition.

This unit is factory charged and should require no further adjustment. If the system requires additional refrigerant, reclaim the charge, evacuate the system and add required nameplate charge.

NOTE - System charging is not recommended below 60°F (15°C). In temperatures below 60°F (15°C), the charge must be weighed into the system.

If weighing facilities are not available, or to check the charge, use the following procedure:

IMPORTANT - Charge unit in normal cooling mode.

- 1 - Attach gauge manifolds to discharge and suction lines. With the economizer disabled, operate the unit in **cooling mode at high speed** using the following mobile service app menu path:

SERVICE>TEST>COOL>COOL 3

- 2 - Use a thermometer to accurately measure the outdoor ambient temperature.
- 3 - Apply the outdoor temperature to TABLE 5 through TABLE 10 to determine normal operating pressures. Pressures are listed for sea level applications at 80°F dry bulb and 67°F wet bulb return air.
- 4 - Compare the normal operating pressures to the pressures obtained from the gauges. Minor variations in these pressures may be expected due to differences in installations. Significant differences could mean that the system is not properly charged or that a problem exists with some component in the system. **Correct any system problems before proceeding.**

- 5 - If discharge pressure is high, remove refrigerant from the system. If discharge pressure is low, add refrigerant to the system.

- Add or remove charge in increments.

- Allow the system to stabilize each time refrigerant is added or removed.

In addition to conventional charging procedures, the following requirements shall be followed.

- Ensure that contamination of different refrigerants does not occur when using charging equipment. Hoses or lines shall be as short as possible to minimize the amount of refrigerant contained in them.
- Cylinders shall be kept in an appropriate position according to the instructions.
- Ensure that the unit is earth grounded prior to charging the system with refrigerant.
- Label the system when charging is complete (if not already).
- Extreme care shall be taken not to overfill the unit.

Prior to recharging the system, it shall be pressure-tested with the appropriate purging gas. The system shall be leak-tested on completion of charging but prior to commissioning. A follow up leak test shall be carried out prior to leaving the site.

- When removing refrigerant from a system, either for servicing or decommissioning, it is recommended good practice that all refrigerants are removed safely.
- When transferring refrigerant into cylinders, ensure that only appropriate refrigerant recovery cylinders are employed. Ensure that the correct number of cylinders for holding the total system charge is available. All cylinders to be used are designated for the recovered refrigerant and labelled for that refrigerant (i. e. special cylinders for the recovery of

refrigerant). Cylinders shall be complete with pressure-relief valve and associated shut-off valves in good working order. Empty recovery cylinders are evacuated and, if possible, cooled before recovery

- The recovery equipment shall be in good working order with a set of instructions concerning the equipment that is at hand and shall be suitable for the recovery of all appropriate refrigerants including, when applicable, flammable refrigerants. In addition, a set of calibrated weighing scales shall be available and in good working order. Hoses shall be complete with leak-free disconnect couplings and in good condition. Before using the recovery machine, check that it is in satisfactory working order, has been properly maintained and that any associated electrical components are sealed to prevent ignition in the event of a refrigerant release. Consult manufacturer if in doubt.
- The recovered refrigerant shall be returned to the refrigerant supplier in the correct recovery cylinder, and the relevant waste transfer note arranged. Do not mix refrigerants in recovery units and especially
- If compressors or compressor oils are to be removed, ensure that they have been evacuated to an acceptable level to make certain that flammable refrigerant does not remain within the lubricant. The evacuation process shall be carried out prior to returning the compressor to the suppliers. Only electric heating to the compressor body shall be employed to accelerate this process. When oil is drained from a system, it shall be carried out safely.

NOTE - System charging is not recommended below 60°F (15°C). In temperatures below 60°F (15°C), the charge must be weighed into the system.

If weighing facilities are not available, or to check the charge, use the following procedure:

- 1 - Make sure outdoor coil is clean. Attach gauge manifolds and operate unit at full CFM in cooling mode with economizer disabled until system stabilizes (approximately five minutes). Make sure all outdoor air dampers are closed.
- 2 - Compare the normal operating pressures to the pressures obtained from the gauges. Check unit components if there are significant differences.
- 3 - Measure the outdoor ambient temperature and the suction pressure. Refer to the charging curve to determine a target liquid temperature.

NOTE - Pressures are listed for sea level applications.

- 4 - Use the same thermometer to accurately measure the liquid temperature (in the outdoor section).
 - If measured liquid temperature is higher than the target liquid temperature, add refrigerant to the system.
 - If measured liquid temperature is lower than the target liquid temperature, recover some refrigerant from the system..
- 5 - Add or remove charge in increments. Allow the system to stabilize each time refrigerant is added or removed.

- 6 - Continue the process until measured liquid temperature agrees with the target liquid temperature. Do not go below the target liquid temperature when adjusting charge. Note that suction pressure can change as charge is adjusted.

Example: At 95°F outdoor ambient and a measured suction pressure of 130psig, the target liquid temperature is 97°F. For a measured liquid temperature of 106°F, add charge in increments until measured liquid temperature agrees with the target liquid temperature. Use the following approach method along with the normal operating pressures to confirm readings.

TABLE 5

LDT/LHT156 NORMAL OPERATING PRESSURES - 581167-02

Outdoor Coil Entering Temp.	CIRCUIT 1		CIRCUIT 2	
	Discharge ± 10 psig	Suction ± 5 psig	Discharge ± 10 psig	Suction ± 5 psig
65 °F	223	123	226	125
75 °F	259	128	261	131
85 °F	298	132	301	134
95 °F	342	135	345	136
105 °F	389	137	392	138
115 °F	443	139	445	140

TABLE 6

LDT/LHT180 NORMAL OPERATING PRESSURES - 581168-02

Outdoor Coil Entering Temp.	CIRCUIT 1		CIRCUIT 2	
	Discharge ± 10 psig	Suction ± 5 psig	Discharge ± 10 psig	Suction ± 5 psig
65 °F	235	128	234	120
75 °F	273	133	272	127
85 °F	313	135	311	132
95 °F	356	136	354	133
105 °F	406	138	402	136
115 °F	461	140	456	138

TABLE 7

LDT/LHT240 NORMAL OPERATING PRESSURES - 581169-02

Outdoor Coil Entering Temp.	CIRCUIT 1		CIRCUIT 2	
	Discharge ± 10 psig	Suction ± 5 psig	Discharge ± 10 psig	Suction ± 5 psig
65 °F	249	129	258	123
75 °F	283	130	294	125
85 °F	323	131	334	126
95 °F	369	131	377	127
105 °F	418	133	428	130
115 °F	471	137	483	132

TABLE 8
LDT/LHT156 NORMAL OPERATING PRESSURES
w/ REHEAT - 581431-01

Outdoor Coil Entering Temp.	CIRCUIT 1		CIRCUIT 2	
	Discharge ± 10 psig	Suction ± 5 psig	Discharge ± 10 psig	Suction ± 5 psig
65 °F	225	127	218	121
75 °F	258	128	254	125
85 °F	295	130	293	127
95 °F	336	132	341	129
105 °F	381	133	390	131
115 °F	433	135	448	135

TABLE 9
LDT/LHT180 NORMAL OPERATING PRESSURES
w/ REHEAT - 581432-01

Outdoor Coil Entering Temp.	CIRCUIT 1		CIRCUIT 2	
	Discharge ± 10 psig	Suction ± 5 psig	Discharge ± 10 psig	Suction ± 5 psig
65 °F	241	127	232	125
75 °F	278	130	267	127
85 °F	319	131	307	129
95 °F	364	132	351	130
105 °F	413	134	398	131
115 °F	467	136	450	135

TABLE 10
LDT/LHT240 NORMAL OPERATING PRESSURES
w/ REHEAT - 581433-01

Outdoor Coil Entering Temp.	CIRCUIT 1		CIRCUIT 2	
	Discharge ± 10 psig	Suction ± 5 psig	Discharge ± 10 psig	Suction ± 5 psig
65 °F	250	122	263	122
75 °F	285	123	302	125
85 °F	324	125	345	127
95 °F	362	126	385	128
105 °F	414	128	442	131
115 °F	466	130	499	133

E-Charge Verification - Approach Method - AHRI Testing (Fin/Tube Coil)

- Using the same thermometer, compare liquid temperature to outdoor ambient temperature.
Approach Temperature = Liquid temperature (at outdoor coil outlet) minus ambient temperature.
- Approach temperature should match values in TABLE 11. An approach temperature greater than value shown indicates an undercharge. An approach temperature less than value shown indicates an overcharge.
- The approach method is not valid for grossly over or undercharged systems. Use TABLE 5 through TABLE 10 as a guide for typical operating pressures.

TABLE 11
APPROACH TEMPERATURES - FUN/TUBE COIL

Unit	Liquid Temp. Minus Ambient Temp.	
	1st Stage	2nd Stage
156	2.3°F +/- 1° (1.3°C +/- 0.5°)	3.4°F +/- 1° (1.9°C +/- 0.5°)
180	2°F +/- 1° (1.1°C +/- 0.5°)	3.5°F +/- 1° (1.9°C +/- 0.5°)
240	5°F +/- 1° (2.8°C +/- 0.5°)	7°F +/- 1° (3.9°C +/- 0.5°)
156 w/ Reheat	2°F +/- 1° (1.1°C +/- 0.5°)	5°F +/- 1° (2.8°C +/- 0.5°)
180 w/ Reheat	4°F +/- 1° (2.2°C +/- 0.5°)	4°F +/- 1° (2.2°C +/- 0.5°)
240 w/ Reheat	3.4°F +/- 1° (1.9°C +/- 0.5°)	12.9°F +/- 1° (7.1°C +/- 0.5°)

F-Compressor Controls

See unit wiring diagram to determine which controls are used on each unit.

- High Pressure Switch (S4, S7)

The compressor circuit is protected by a high pressure switch which opens at 640 psig ± 10 psig (4413 kPa ± 70 kPa) and automatically resets at 475 psig + 20 psig (3275 kPa ± 138 kPa).

- Low Pressure Switch (S87, S88)

The compressor circuit is protected by a low pressure switch. Switch opens at 40 psig ± 5 psig (276 ± 34 kPa) and automatically resets at 90 psig ± 5 psig (621 kPa ± 34 kPa).

- Crankcase Heater (HR1, HR2)

Units have compressors which contain a belly band compressor oil heater which must be on 24 hours before running compressors. Energize by setting thermostat so that there is no cooling demand, to prevent compressor from cycling, and apply power to unit.

- Outdoor Fan Operation

Outdoor fans 1, 2, and 3 are energized when compressor 1 is energized. As cooling demand increases, all six outdoor fans are energized. See FIGURE 25.

Outdoor fans 2, 3, 5, and 6 are de-energized when outdoor temperature drops below 62°F (17°C).

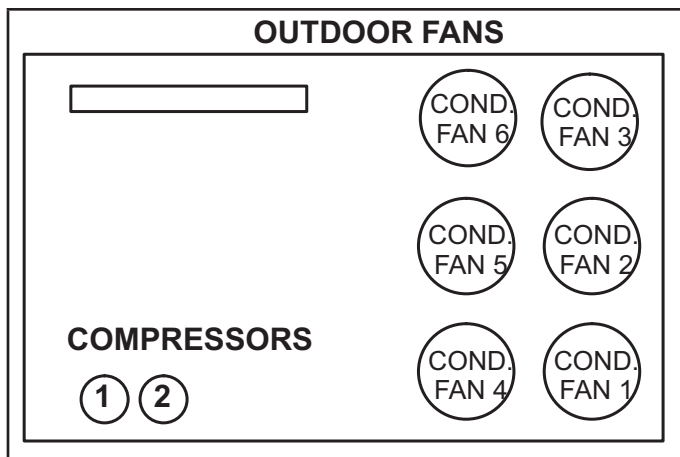

FIGURE 25

Heating Start-Up (LDT)

FOR YOUR SAFETY READ BEFORE LIGHTING

BEFORE LIGHTING smell all around the appliance area for gas. Be sure to smell next to the floor because some gas is heavier than air and will settle on the floor.

Use only your hand to push in or turn the gas control knob. Never use tools. If the knob will not push in or turn by hand, do not try to repair it, call a qualified service technician. Force or attempted repair may result in a fire or explosion.

The unit is equipped with an automatic spark ignition system. There is no pilot. In case of a safety shutdown, move thermostat switch to **OFF** and return the thermostat switch to **HEAT** to reset ignition control.

⚠ WARNING



Electric shock hazard. Can cause injury or death. Do not use this unit if any part has been under water. Immediately call a qualified service technician to inspect the unit and to replace any part of the control system and any gas control which has been under water.

⚠ WARNING



Danger of explosion. Can cause injury or product or property damage. If overheating occurs or if gas supply fails to shut off, shut off the manual gas valve to the appliance before shutting off electrical supply.

⚠ WARNING



Electric shock hazard. Can cause injury or death. Before attempting to perform any service or maintenance, turn the electrical power to unit OFF at disconnect switch(es). Unit may have multiple power supplies.

⚠ WARNING

SMOKE POTENTIAL

The heat exchanger in this unit could be a source of smoke on initial firing. Take precautions with respect to building occupants and property. Vent initial supply air outside when possible.

⚠ WARNING



Danger of explosion. Can cause injury or death. Do not attempt to light manually. Unit has a direct spark ignition system.

⚠ WARNING



Danger of explosion and fire. Can cause injury or product or property damage. You must follow these instructions exactly.

A-Placing Unit In Operation

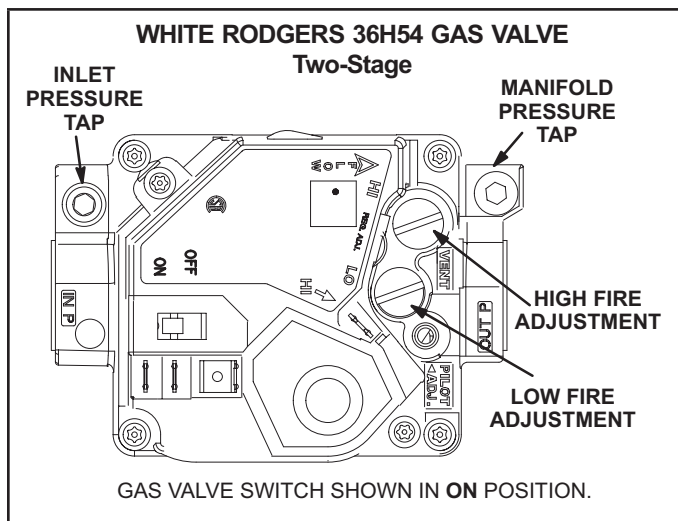

FIGURE 26

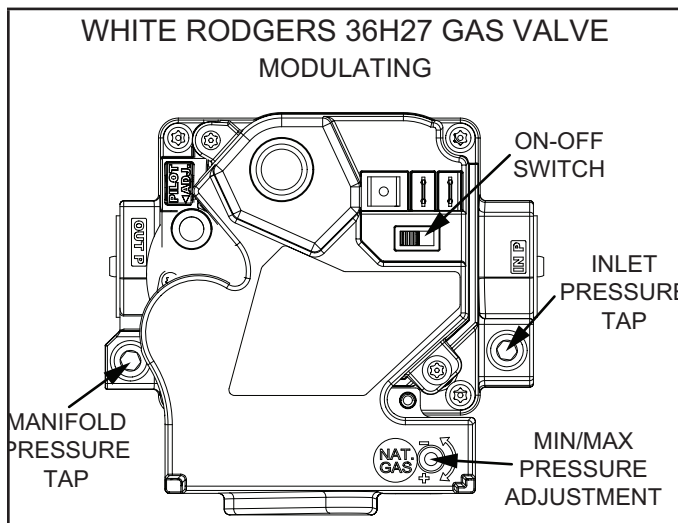

FIGURE 27

- 1 - Set thermostat to lowest setting.
- 2 - Turn off all electrical power to appliance.
- 3 - This appliance is equipped with an ignition device which automatically lights the burner. Do not try to light the burner by hand.
- 4 - Open or remove the heat section access panel.
- 5 - Turn gas valve switch to **OFF**. See FIGURE 26 and FIGURE 27.
- 6 - Wait five (5) minutes to clear out any gas. If you then smell gas, **STOP!** Immediately call your gas supplier from a neighbor's phone. Follow the gas supplier's instructions. If you do not smell gas, go to the next step.
- 7 - Turn gas valve switch to **ON**. See FIGURE 26 and FIGURE 27.
- 8 - Close or replace the heat section access panel.
- 9 - Turn on all electrical power to appliance.

NOTE - When unit is initially started, steps 1 through 9 may need to be repeated to purge air from gas line.

- 10 - Set thermostat to desired setting.
- 11 - The ignition sequence will start.
- 12 - If the appliance does not light the first time (gas line not fully purged), it will attempt up to two more ignitions before locking out.
- 13 - If lockout occurs, repeat steps 1 through 10.
- 14 - If the appliance will not operate, follow the instructions "Turning Off Gas to Appliance" and call your service technician or gas supplier.

Turning Off Gas to Unit

- 1 - If using an electromechanical thermostat, set to the lowest setting.
- 2 - Before performing any service, turn off all electrical power to the appliance.
- 3 - Open or remove the heat section access panel.
- 4 - Turn gas valve switch to **OFF**.
- 5 - Close or replace the heat section access panel.

⚠ WARNING	
	Danger of explosion. Can cause injury or death. Do not attempt to light manually. Unit has a direct spark ignition system.

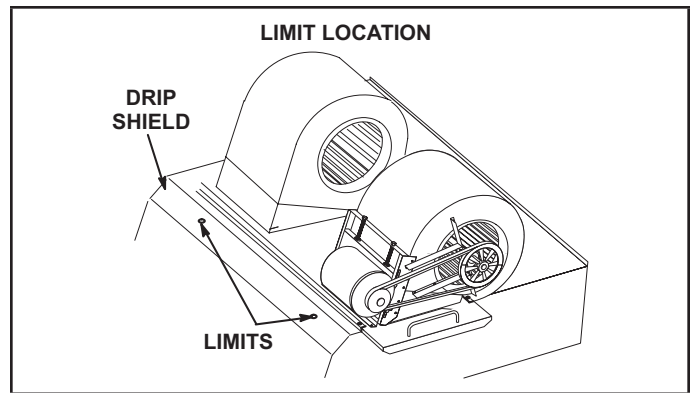

FIGURE 28

Gas Heating Operation

A-Heating Sequence of Operation

Two-Stage and Modulating

- 1 - On a heating demand the CORE transmits a demand signal (W1, W2) to the Direct Spark Ignition (DSI) control. For Modulating systems, CORE transmits an additional signal, Gas Valve Position, to the DSI control.
- 2 - DSI control immediately activates the combustion air inducer.
- 3 - Combustion air pressure switch proves inducer operation before allowing ignition sequence to start.
- 4 - After a 30 second pre-purge time, DSI control energizes the spark ignitor and opens the gas valve to Low Fire (Two-Stage) or minimum position (Modulating).
- 5 - The spark then ignites the gas and flame is verified by flame sensor.

NOTE - If flame is not detected, the DSI control will close the gas valve and repeat steps 4 and 5 two more times.

- 6 - After the warmup period ends, CORE control starts the blower operation.

Heating Demand – Two-Stage

- 1 - CORE operates indoor blower at the Blower Heating High CFM Setpoint (refer to TABLE 15).
- 2 - When thermostat initiates W2 demand, CORE transmits W2 signal to DSI control.
- 3 - DSI control opens the gas valve to High Fire and changes CAI speed from low to high.

Heating Demand – Modulating

- 1 - CORE operates indoor blower at Blower Heating Low CFM setpoint (refer to TABLE 15).
- 2 - MGV Position is consistently updated by the CORE during heating demand.
 - a. CORE monitors the Discharge Air Temperature (DAT) sensor and compares its value to the setpoint.
 - b. CORE calculates a new MGV Position.

- c. CORE transmits new MGVP Position to MGVP which responds accordingly.
 - d. Steps a) thru c) are repeated until heating demand has been satisfied.
- 3 - Increasing MGVP Position (minimum, moving toward maximum).
- a. When CORE increases the MGVP Position above programmed value, CORE outputs W2 signal to the DSI control.
 - b. DSI control changes CAI speed from low to high.
 - c. CORE changes indoor blower operation to Blower Heating High CFM setpoint (refer to TABLE 15).
- 4 - Decreasing MGVP Position (maximum, moving toward minimum).
- a. When CORE decreases MGVP Position to minimum and CORE holds MGVP in minimum position for preset time period, CORE removes W2 signal to DSI control.
 - b. DSI control changes CAI speed from high to low.
 - c. CORE changes indoor blower operation to Blower Heating Low CFM setpoint (refer to TABLE 15).

Termination – Two-Stage and Modulating

- 1 - When thermostat demand is satisfied, heating demands (W1, W2) are removed from CORE.
- 2 - CORE removes any active demand signals (W1, W2) to DSI control. For Modulating systems, the CORE removes the MGVP Position signal too.
- 3 - DSI control closes the gas valve.
- 4 - DSI control maintains CAI operation for post purge period (45 seconds), then shuts off CAI.
- 5 - CORE maintains indoor blower operation until Gas Blower Off Delay expires, then CORE shuts off the indoor blower.

B-Ignition Control Diagnostic LEDs

The table below refers to several components. The components and wiring diagram key numbers are: DSI Control Board (A3); Gas Valve (GV1 or GV4); Primary Limit Switch (S10); Combustion Air Blower Proofing Switch (S18); Rollout Switch (S47). Refer to the unit wiring diagram for further details.

TABLE 12

IGNITION CONTROL HEARTBEAT LED STATUS

LED Flashes	Indicates
Slow Flash	Normal Operation – No call for heat
Fast Flash	Normal Operation - call for heat
Steady Off	Internal control board fault or no power
Steady On	Control board failure
1 Flash	Rollout Switch open
2 Flashes	Limit Switch open or opened multiple times during one heating demand
3 Flashes	Pressure Switch open with CAI ON
4 Flashes	Control lockout – failed to detect or sustain flame
5 Flashes	Flame sensed and gas valve not energize
6 Flashes	Pressure Switch closed with CAI OFF
7 Flashes	Not used
8 Flashes	Pressure switch opened repeatedly during heating demand

Gas Heating Checks and Adjustments

A-Gas Flow

To check for proper gas flow, determine the Btu input from the unit rating plate. Divide this input rating by the Btu per cubic feet of available gas. Result is the required number of cubic feet per hour. Determine the flow of gas through the gas meter for two minutes and multiply by 30 to get the hourly flow of gas.

B-Supply Gas Pressure

Supply pressure should be checked with unit firing at maximum rate. For Natural Gas, supply pressure should be maintained in accordance with the specified minimum and maximum supply pressures on the unit rating plate.

For LP/propane, a natural gas to LP/propane gas changeover kit is required to convert the unit in the field. Refer to installation instructions provided with changeover kit for conversion procedure along with propane minimum and maximum supply pressures.

NOTE - On multiple unit installations, each unit should be checked separately, with and without other units operating. Supply pressures on both single and multiple unit installations must fall within range listed on the rating plate.

C-Supply Gas Pressure Measurement

- 1 - Shut off the manual main supply valve (field furnished) when installing or removing the measuring device (Steps 2 and 6).
- 2 - Connect the measuring device based upon type of gas valve.

For White Rodgers 36H54 and 36H27 valves (FIGURE 26 and FIGURE 27), supply pressure is accessed by removing 1/8" hex screw. Remove the 1/8" hex screw and install a 1/8" fitting with hose barb. Connect tubing from the barbed fitting and route to measuring device to measure supply pressure.

- 3 - Open manual main supply valve.

- 4 - Ignite unit and let run for 5 minutes to allow for steady state conditions.
- 5 - After allowing unit to stabilize for 5 minutes, record supply pressure.
- 6 - Shut unit off and remove measuring device, tubing, or fittings as soon as an accurate reading has been obtained.

For White Rodgers 36H54 and 36H27 valves (FIGURE 26 and FIGURE 27), remove supply pressure barbed fitting and reinstall the 1/8" hex screw.

D-Manifold Pressure Measurement and Adjustment

- 1 - Connect the measuring device based upon the type of gas valve.
For White Rodgers 36H54 and 36H27 valves (FIGURE 26 and FIGURE 27) manifold pressure, remove the 1/8" hex screw, install 1/8" fitting with hose barb, connect hose from barb to "+" side of measuring device.
- 2 - Ignite unit and let run for 5 minutes to allow for steady state conditions. If unit has 2 heating inputs, start on higher input.
- 3 - After allowing unit to stabilize for 5 minutes, record manifold pressure. Compare measurement to the unit nameplate values.

NOTE - For elevations higher than 4500 feet above sea level, see High Altitude Adjustment section for details.

- 4 - If necessary, adjust manifold pressure. FIGURE 26 and FIGURE 27 show adjustment screw(s) locations.
- 5 - Repeat steps 3, 4 and 5 on lower input.
- 6 - Shut unit off and remove measuring device as soon as accurate reading has been obtained.
For White Rodgers 36H54 and 36H27 valves (FIGURE 26 and FIGURE 27), remove 1/8" fitting with hose barb and reinstall 1/8" hex screw.
- 7 - Start unit and perform leak check. Seal leaks if found.

E-High Altitude Adjustments

Locate the high altitude conversion sticker in the unit literature bag. Fill out the conversion sticker and affix next to the unit nameplate. High altitude kits are available for field-installation.

Refer to TABLE 13 for high altitude adjustments.

TABLE 13

Altitude in Feet (Meters)*	Gas Manifold Pressure
2001 – 4500 (610 – 1372)	See unit nameplate
4500 (1372) and Above	Derate 4% per 1000 ft. (305 m) above sea level

*Units installed at 0-2000 feet do not need to be modified

NOTE - This is the only permissible derate for these units.

Heating Start-Up (LHT)

NOTE - L1 & L2 reversing valves are de-energized with a heating demand. The heat pump will heat only, not cool.

- 1 - Set thermostat or temperature control device to initiate a first-stage heating demand.
- 2 - A first-stage heating demand (W1) will energize compressors 1 and 2, the outdoor fans, and blower.

NOTE - W1 will also energize optional factory- or field-installed electric heat during defrost to maintain discharge air temperature.

- 3 - A second-stage heating demand (W2) will energize optional electric heat.

Defrost Control

The defrost control ensures that the heat pump outdoor coil does not ice excessively during the heating mode. Defrost is enabled below 35°F. The Unit Controller will cycle in and out of defrost depending on the temperature difference between the outdoor coil and outdoor air temperature. If the system fails to calibrate or obtain readings for demand defrost, defrost will run-time at the field setting.

Defrost is also initiated when the accumulated run time with the outdoor coil temperature below 35°F reaches six hours. Low gas heat (LDT) or electric heat (optional on LHT) is energized during defrost.

NOTE - Only one refrigerant circuit will go into defrost at a time.

Defrost Test or Forced Defrost Option

A TEST option is provided for troubleshooting. The TEST mode may be started at any time using the mobile service app. Defrost mode may be started by entering the Defrost Mode in the Component Test Menu. When defrost is started, unit will run in Defrost Mode for a maximum of five minutes or when the outdoor coil reaches 100°F, whichever occurs first.

Multi-Staged Air Volume Start-Up

A-Design Specifications

Use TABLE 14 to fill in field-provided, design specified blower CFM for appropriate unit.

If only high and low cooling design specifications are provided, set the medium cooling CFM at the high or low cooling design spec or any CFM between.

B-Set Maximum CFM

Use TABLE 15 to determine highest blower CFM for appropriate unit. Adjust the blower pulley to deliver that amount of CFM with only the blower operating. See Determining Unit CFM in the Blower Operation and Adjustment section.

C-Set Blower Speeds

Use the following mobile service app menu to enter the blower design specified CFM into the Unit Controller. Make sure blower CFM is within limitations shown in TABLE 15 or TABLE 16. Refer to the Unit Controller manual provided with unit.

RTU MENU > RTU OPTIONS > BLOWER > SPEED

Enter the following design specifications as shown in TABLE 14.

- Blower / Heat CFM
- Cooling High CFM
- Cooling Low CFM
- Vent CFM

Adjust the blower RPM to deliver the target CFM based on the measured static pressure using the blower table.

Measure the static pressure again and apply the static pressure and RPM to the blower tables to determine adjusted CFM.

Repeat adjustments until design CFM is reached.

D-Set Damper Minimum Position

To maintain required minimum ventilation air volumes when the unit is in the occupied mode, two minimum damper positions must be set.

The Unit Controller will open the damper to “Min OCP Blwr High” when blower CFM is at or ABOVE the “midpoint” CFM.

The Unit Controller will open the dampers to “Min OCP Blwr Low” when blower CFM is BELOW a “midpoint” CFM.

The Unit Controller will calculate the “midpoint” CFM.

Set Minimum Position 1

Use the following mobile service app menu to set “Min OCP Blwr High” for the blower CFM above the “midpoint” CFM. When navigating into this menu, the Unit Controller will run damper calibration and allow damper position adjustment.

RTU MENU > SETTINGS > RTU OPTIONS > DAMPER

Tap “Next” to skip tabs and complete damper position calibration until “Damper Calibration Blower Speed High” tab appears.

Measure the intake air CFM. If the CFM is lower than the design specified CFM for ventilation air, use the Unit Controller to increase the damper percent open. If the CFM is higher than specified, decrease the damper percent open.

NOTE - Intake air CFM can also be determined using the outdoor air temperature, return air temperature and mixed air temperature. Refer to the economizer or outdoor air damper installation instructions.

TABLE 14
Blower CFM Design Specifications

Unit	T'Stat or Zone Control Stages	Blower Speed	Design Specified CFM
156	2	Htg.	
		Clg. High	
		Clg. Low	
		Ventilation	
180	2	Htg.	
		Clg. High	
		Clg. Low	
		Ventilation	
240	2	Htg.	
		Clg. High	
		Clg. Low	
		Ventilation	

*Available blower speeds vary by unit and thermostat stages.

**TABLE 15
HEATING, VENTILATION & SMOKE MINIMUM AND MAXIMUM CFM**

Unit			Heating CFM			Vent CFM			Smoke CFM										
Model	Speed	Heat Code	Default	Min	Max	Default	Min	Max	Default	Min	Max								
LDT156H	Low	L	6000	2725	6250	5200	1950	6250	5200	1950	6250								
	Std	S		4325															
	Med	M		4500															
LHT156H	HP W/O EH	N		3900															
	15, 30, 45, 60, 90 KW	E, J, K, L,		6000															
LDT180H	Low	L	6000	2725	7200	6000	2250	7200	6000	2250	7200								
	Std	S		4325															
	Med	M		4500															
	High	H		5125															
LHT180H	HP W/O EH	N		4500															
	15, 30, 45, 60, 90 KW	E, J, K, L, P		6000															
LDT240H	Low, Std, Med	L, S, M	8000	4500	9600	8000	3000	9600	8000	3000	9600								
	High	H		5125															
LHT240H	HP W/O EH	N										6000							
	15, 30, 45, 60, 90 KW	E, J, K, L, P										6000							

*Use highest value between Heating and Cooling High CFM max

**TABLE 16
COOLING MINIMUM AND MAXIMUM CFM**

LHT / LDT Unit	Cooling Low CFM			Cooling High CFM		
	Default	Min	Max	Default	Min	Max
156H	2350	1500	6250	4675	4000	6250
180H	2700	2000	7200	5400	5000	7200
240H	3600	3000	9600	7200	6250	9600

*Use Cooling High CFM Max

Set Minimum Position 2

Use the following mobile service app menu in the Unit Controller to set "Min OCP Blwr Low" for the blower CFM below the "midpoint" CFM. When navigating into this menu, the Unit Controller will run damper calibration and allow damper position adjustment.

RTU MENU > SETTINGS > RTU OPTIONS > DAMPER

Tap "Next" to skip tabs and complete damper position calibration until "Damper Calibration Blower Speed High" tab appears.

Measure the intake air CFM. If the CFM is lower than the design specified CFM for ventilation air, use the Unit Controller to increase the damper percent open. If the CFM is higher than specified, decrease the damper percent open.

NOTE - Intake air CFM can also be determined using the outdoor air temperature, return air temperature and mixed air temperature. Refer to the economizer or outdoor air damper installation instructions.

E-Inverter Bypass Option

The supply air inverter is factory-set to by-pass the inverter manually. To by-pass the inverter and operate the blower in the constant air volume mode, use the following Unit Controller menu and set to "engaged":

SETTINGS > RTU OPTIONS > BLOWER > VFD BYPASS

To configure the unit to by-pass the inverter automatically, use the following Unit Controller menu.

SETUP > INSTALL

Press SAVE until the menu reads:

CONFIGURATION ID 1

Change the 6th character position to A for automatic bypass option.

Press SAVE

CAUTION - Units not equipped with an inverter will have the 6th character set to N, indicating the inverter is not by-passed. The blower motor could be damaged and/or result in product or property damage if the setting is changed to automatic or manual.

Multi-Staged Air Volume Operation

This is a summary of cooling operation. Refer to the sequence of operation provided in the Engineering Handbook or Service Manual for more detail.

A-Two-Stage Thermostat

1 - Economizer With Outdoor Air Suitable

Y1 Demand -

All compressors are off, supply air blower is on low cooling speed to minimize blower power consumption, economizer modulates (minimum to maximum open position) to maintain 55°F supply air temperature (default unit controller setting).

Y2 Demand -

All compressors are off, supply air blower is on high cooling speed providing higher cooling capacity, and economizer modulates to maintain 55°F supply air temperature. If economizer stays at maximum open for 3 minutes, compressor 1 is energized while supply air blower stays on high cooling speed providing maximum cooling capacity.

NOTE - If dampers are at maximum open for three minutes, compressor 1 is energized low and blower stays on cooling high.

2 - No Economizer or Outdoor Air Not Suitable

Y1 Demand -

Compressor 1 operates, and supply air blower operates at low cooling speed.

Y2 Demand -

All compressors operate and supply air blower operates at high cooling speed.

C-Three-Stage Thermostat

1 - Economizer With Outdoor Air Suitable

Y1 Demand -

All compressors are off, supply air blower is on low cooling speed to minimize blower power consumption, economizer modulates (minimum to maximum open position) to maintain 55°F supply air temperature (default unit controller setting).

Y2 Demand -

All compressors are off, supply air blower is on high cooling speed providing higher cooling capacity, and economizer modulates to maintain 55°F supply air temperature. If economizer stays at maximum open for 3 minutes, compressor 1 is energized while supply air blower stays on high cooling speed providing maximum cooling capacity. After compressors are energized the economizer stays at maximum open.

NOTE - If dampers are at maximum open for three minutes, compressor 1 is energized low and blower stays on cooling high.

Y3 Demand -

Compressors 1 and 2 are energized while supply air blower stays on high cooling speed.

2 - No Economizer or Outdoor Air Not Suitable

Y1 Demand -

Compressor 1 operates at part load and supply air blower operates at low cooling speed.

Y2 Demand -

Compressor 1 operates at part load with compressor 2 ON, and supply air blower operates at medium cooling speed.

Y3 Demand -

All compressors operate and supply air blower operates at high cooling speed.

D-Defrost

Coil Sensors (RT48 - Circuit 1 and RT49 - Circuit 2) and Ambient Sensor (RT17) provides input to the Lennox® CORE Unit Controller to initiate a defrost cycle if needed.

Coil sensors are located on a return bend for each circuit on the front of the outdoor coil.

Ambient sensor is located on the inside of the corner mullion on the back of the outdoor coil section.

If a coil sensor measures a temperature below 35°F during mechanical heating mode, defrost logic is enabled. The system will constantly monitor coil and ambient temperatures and will initiate a defrost cycle if the controller determines that the target temperature difference between the coil and ambient temperature has been satisfied, or when the accumulated run time with coil temperature below 35°F reaches 6 hours.

Defrost will not be activated on more than one circuit at the time.

If the ambient sensor fails, or the circuit is in uncalibrated state, the controller will switch to time/temperature defrost operation.

Electric heat is energized during a defrost cycle to maintain discharge air temperature.

Hot Gas Reheat Start-Up

General

Hot gas reheat units provide a dehumidifying mode of operation. These units contain a reheat coil adjacent to and downstream of the evaporator coil. The reheat coil solenoid valve L14 routes hot discharge gas from the compressor to the reheat coil. Return air pulled across the evaporator coil is cooled and dehumidified; the reheat coil adds heat to supply air.

See FIGURE 29 for refrigerant routing.

L14 Reheat Coil Solenoid Valve

When Unit Controller (P298-5 or J299-8) indicates room conditions require dehumidification, See FIGURE 10 through FIGURE 12. L14 reheat valve is energized (Unit Controller J466) and refrigerant is routed to the reheat coil.

Reheat Setpoint

Reheat is factory-set to energize when indoor relative humidity rises above 60% (default). The reheat setpoint can be adjusted by changing mobile service app *Settings - Control* menu. A setting of 100% will operate reheat from an energy management system digital output. The reheat setpoint can also be adjusted using an optional Network Control Panel (NCP).

Reheat will terminate when the indoor relative humidity falls 3% (57% default) or the digital output de-energizes. The reheat deadband can be adjusted at Settings - Control menu.

A91 Humidity Sensor

Relative humidity should correspond to the sensor (A91) output voltage listed in table 20. For example: if indoor air relative humidity is 80% \pm 3%, the humidity sensor output should read 8.00VDC.

Check the sensor output annually for accuracy. Keep the air intake openings on the sensor clean and free of obstructions and debris.

TABLE 17

Relative Humidity (%RH + 3%)	Sensor Output (VDC)
20	2.00
30	3.00
40	4.00
50	5.00
60	6.00
70	7.00
80	8.00
90	9.00

Check-Out

Test hot gas reheat operation using the following procedure.

- 1 - Make sure reheat is wired as shown in wiring section.
- 2 - Make sure unit is in local thermostat mode.
- 3 - Use mobile service app menu path to select:

SERVICE > TEST > DEHUMIDIFIER

The blower, compressor 1 (reheat) and compressor 2 should be operating. Reheat mode will appear on the mobile service app display.

- 4 - Deselect:

SERVICE > TEST > DEHUMIDIFIER

Compressor 1 and 2 (reheat should de-energize, blower should still be energized).

Additional Cooling Stages

Units are shipped from the factory to provide two stages of cooling.

Compressor 1 is not de-energized when unit operation changes from cooling to reheat or from reheat to cooling. Instead, L14 reheat valve is energized (reheat) or de-energized (cooling).

NOTE - Another thermostat staging option is available which allows both compressors to be energized during free cooling. See Unit Controller manual for details.

REFRIGERANT SCHEMATIC

NOTE - One refrigerant circuit operates during reheat.

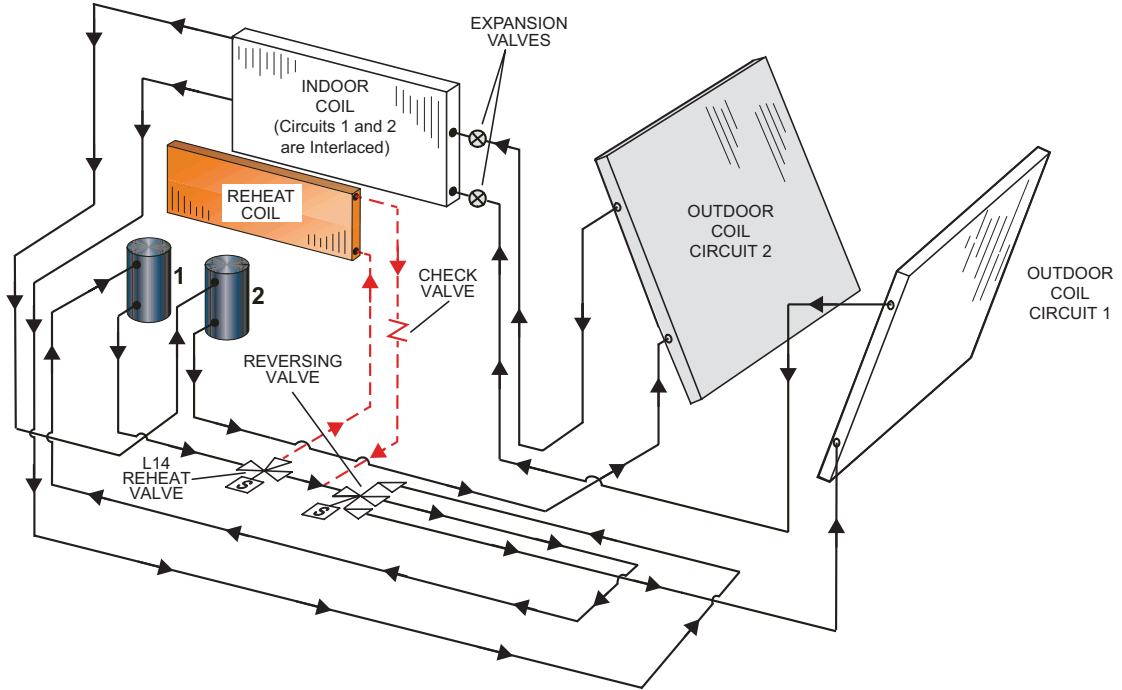

FIGURE 29

Diagnostic Sensors

Units are equipped with four factory-installed thermistors (RT46 - RT49) located on different points on the refrigerant circuit.

The thermistors provide the Unit Controller with constant temperature readings of four specific locations on the refrigeration circuit. These temperatures are used as

feedback in certain modes of unit operation. In addition, the Unit Controller uses these temperatures to initiate alarms such as loss of outdoor or indoor coil airflow and loss of charge.

Each thermistor must be specifically placed for proper unit operation and to initiate valid alarms. See FIGURE 30 for indoor coil location and FIGURE 31 for outdoor coil location.

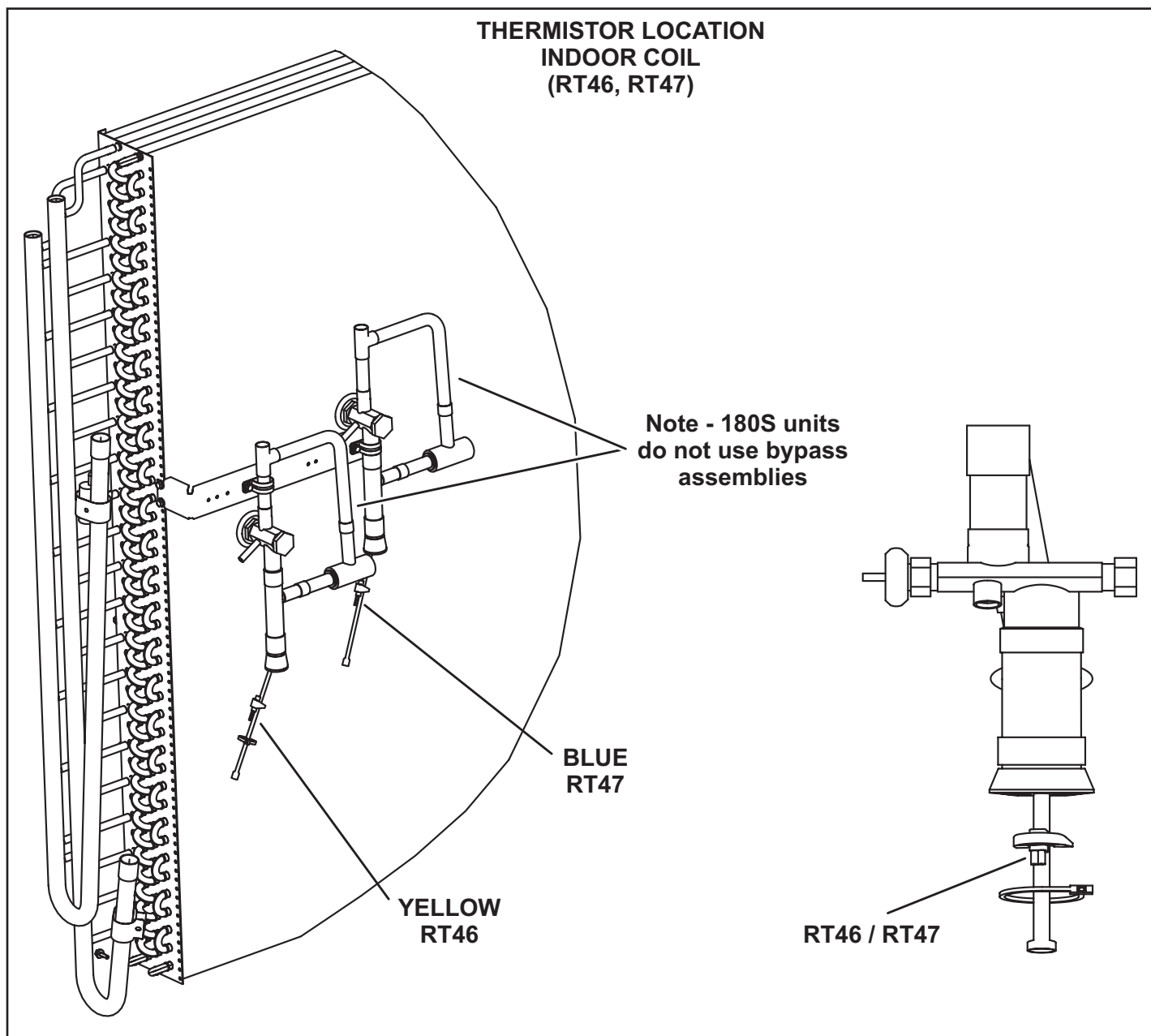

FIGURE 30

**THERMISTOR LOCATION
OUTDOOR COIL
(RT48, RT49)**

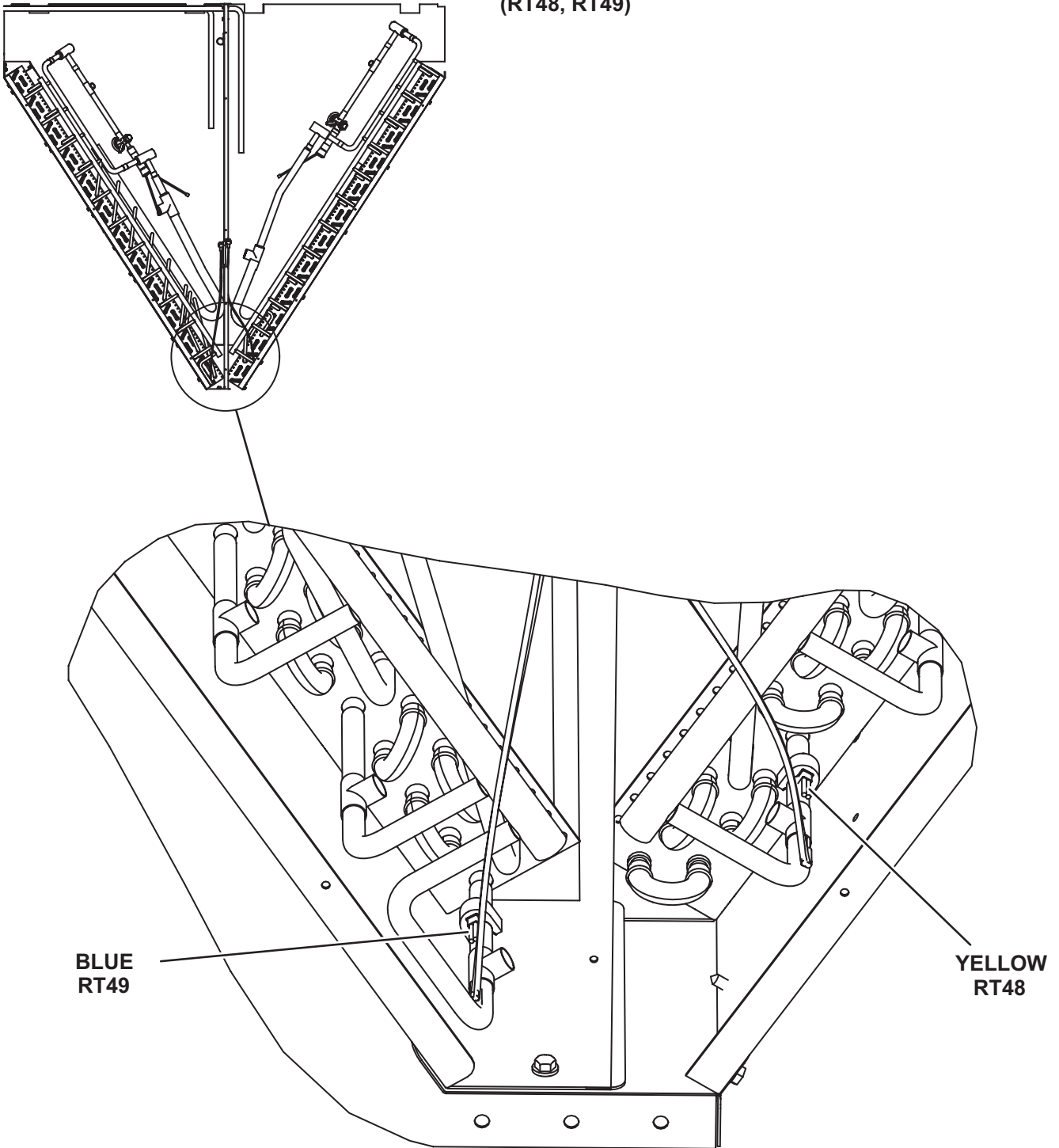

FIGURE 31

RDS Sensors

Units are equipped with factory-installed RDS Sensors located on different points on the unit. The RDS sensors provide the Unit Controller with continuous readings for leaked refrigerant concentration levels and sensor health status (Good or Fault). These readings are used to modify unit operation to disperse the leaked refrigerant and to remove possible ignition sources. In addition, the Unit Controller uses these readings to initiate alarms to alert the operator of a refrigerant leak or faulty sensor(s).

Each sensor must be specifically placed for proper unit operation and to initiate valid alarms. To identify sensor locations see TABLE 15.

TABLE 18

RDS Sensor Figures

Model	Qty.	Type	Figure
LHT/LDT156-240	2 sensors	INDOOR SENSOR	FIGURE 32
		COMPRESSOR SENSOR	FIGURE 33

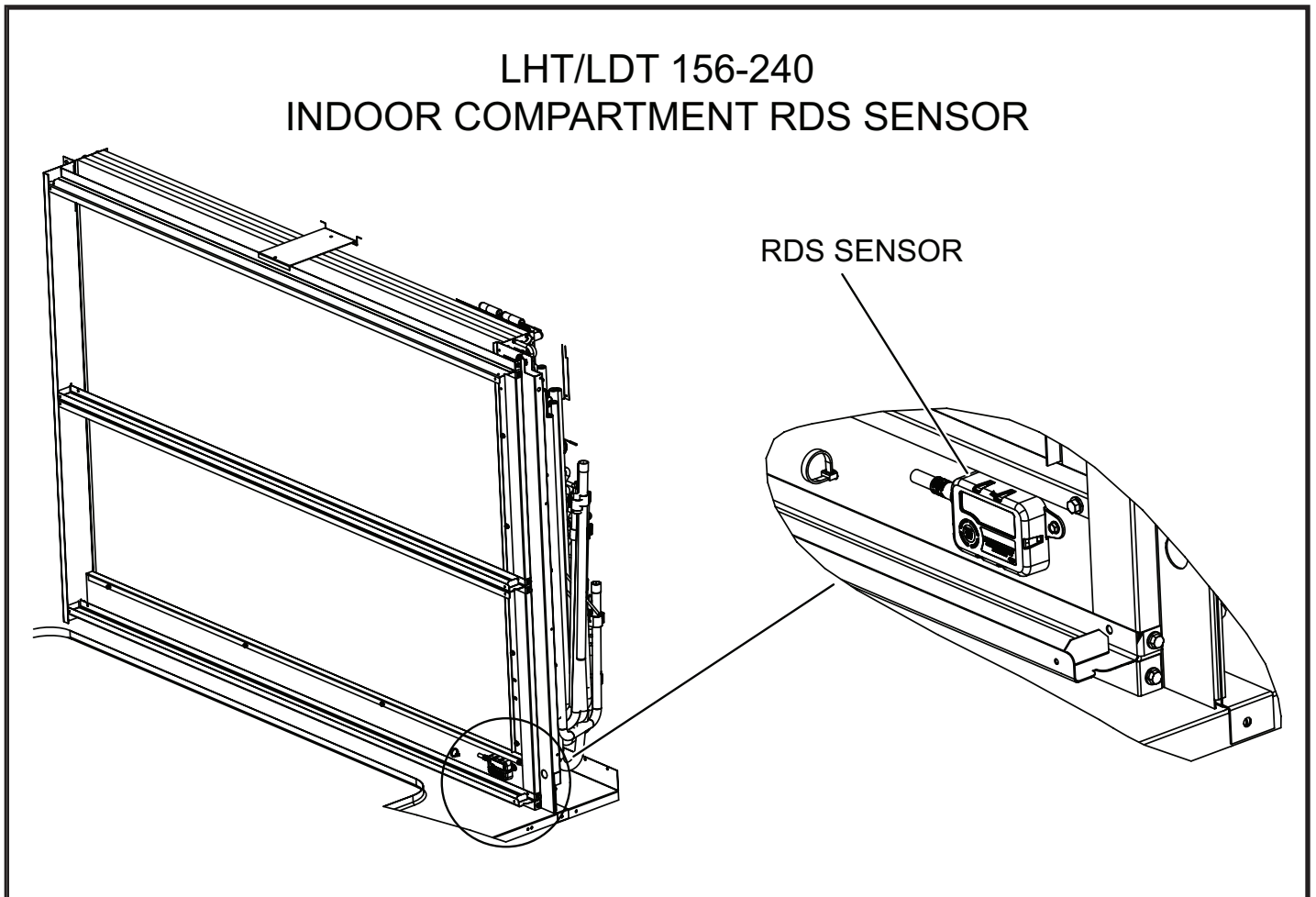

FIGURE 32

LHT/LDT 156-240
COMPRESSOR RDS SENSOR

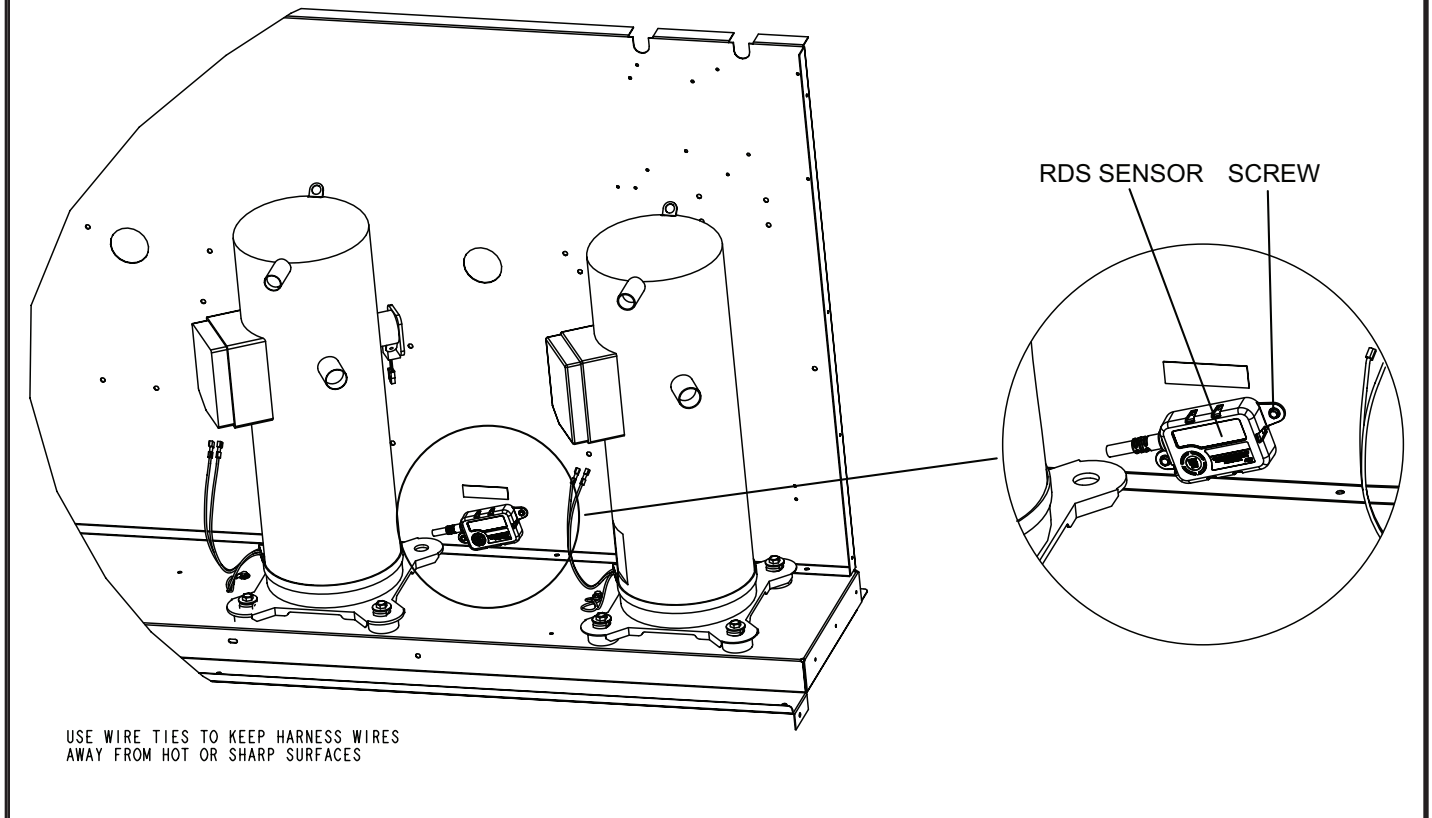

FIGURE 33

Preventative Maintenance / Repair

IMPORTANT MAINTENANCE / REPAIR SAFETY INSTRUCTIONS

Prior to beginning work on systems containing FLAMMABLE REFRIGERANTS, safety checks are necessary to ensure that the risk of ignition is minimized.

Work shall be undertaken under a controlled procedure to minimize the risk of a flammable gas or vapor being present while the work is being performed.

All maintenance staff and others working in the local area shall be instructed on the nature of work being carried out. Work in confined spaces shall be avoided.

The area shall be checked with an appropriate refrigerant detector prior to and during work, to ensure the technician is aware of potentially toxic or flammable atmospheres. Ensure that the leak detection equipment being used is suitable for use with all applicable refrigerants, i.e. non-sparking, adequately sealed or intrinsically safe.

If any hot work is to be conducted on the refrigerating equipment or any associated parts, appropriate fire extinguishing equipment shall be available to hand. Have a dry powder or CO2 fire extinguisher adjacent to the charging area.

No person carrying out work in relation to a REFRIGERATING SYSTEM which involves exposing any pipe work shall use any sources of ignition in such a manner that it may lead to the risk of fire or explosion. All possible ignition sources, including cigarette smoking, should be kept sufficiently far away from the site of installation, repairing, removing and disposal, during which refrigerant can possibly be released to the surrounding space. Prior to work taking place, the area around the equipment is to be surveyed to make sure that there are no flammable hazards or ignition risks. "No Smoking" signs shall be displayed.

Where electrical components are being changed, they shall be fit for the purpose and to the correct specification. At all times, the manufacturer's maintenance and service guidelines shall be followed. If in doubt, consult the manufacturer's technical department for assistance.

Repair and maintenance to electrical components shall include initial safety checks and component inspection procedures. If a fault exists that could compromise safety, then no electrical supply shall be connected to the circuit until it is satisfactorily dealt with. If the fault cannot be corrected immediately but it is necessary to continue operation, an adequate temporary solution shall be used. This shall be reported to the owner of the equipment so all parties are advised.

Initial safety checks shall include:

- that capacitors are discharged: this shall be done in a safe manner to avoid possibility of sparking
- that no live electrical components and wiring are exposed while charging, recovering or purging the system
- that there is continuity of earth bonding

The following checks shall be applied to installations using FLAMMABLE REFRIGERANTS:

- the actual REFRIGERANT CHARGE is in accordance with the room size within which the refrigerant containing parts are installed;
- the ventilation machinery and outlets are operating adequately and are not obstructed;
- if an indirect refrigerating circuit is being used, the secondary circuit shall be checked for the presence of refrigerant;
- marking to the equipment continues to be visible and legible. Markings and signs that are illegible shall be corrected;
- refrigerating pipe or components are installed in a position where they are unlikely to be exposed to any substance which may corrode refrigerant containing components, unless the components are constructed of materials which are inherently resistant to being corroded or are suitably protected against being so corroded.

During repairs to sealed electrical components, the components shall be replaced. Replacement parts shall be in accordance with the manufacturer's specifications.

During repairs to intrinsically safe components, the components must be replaced. Replace components only with parts specified by the manufacturer. Other parts may result in the ignition of refrigerant in the atmosphere from a leak.

The unit should be inspected once a year by a qualified service technician.

A-Filters

Units are equipped with six 24 X 24 X 2" filters. Filters should be checked monthly and replaced when necessary with filters of like kind and size. Take note of air flow direction marking on filter frame when reinstalling filters. See FIGURE 34.

NOTE - Filters must be U.L.C. certified or equivalent for use in Canada.

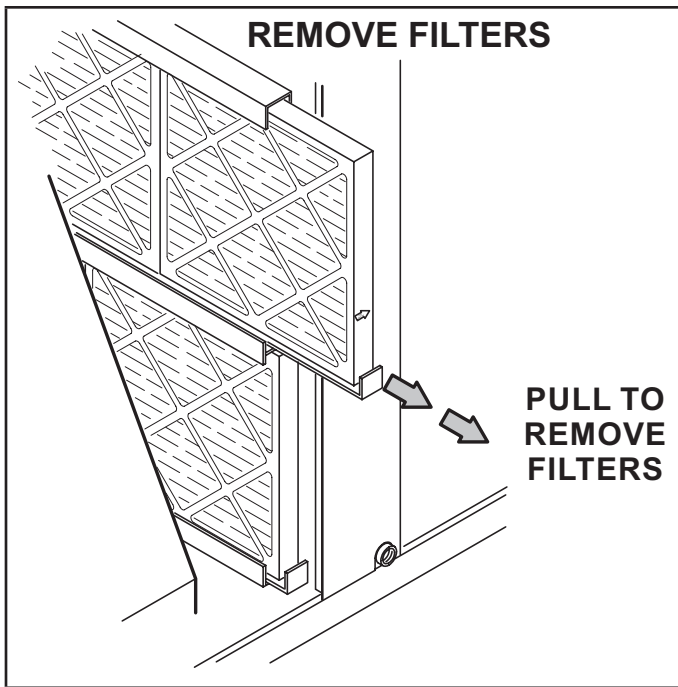

FIGURE 34

⚠ CAUTION

Label all wires prior to disconnection when servicing controls. Wiring errors can cause improper and dangerous operation. Verify proper operation after servicing.

B-Lubrication

All motors are lubricated at the factory. No further lubrication is required.

Blower shaft bearings are prelubricated. For extended bearing life, relubricate at least once every two years with a lithium base grease, such as Alvania 3 (Shell Oil), Chevron BRB2 (Standard Oil) or Regal AFB2 (Texas Oil). Use a hand grease gun for relubrication. Add only enough grease to purge through the bearings so that a bead of grease appears at the seal lip contacts.

C-Burners (Gas Units)

Periodically examine burner flames for proper appearance during the heating season. Before each heating season examine the burners for any deposits or blockage which may have occurred.

Clean burners as follows:

- 1 - Turn off both electrical power and gas supply to unit.
- 2 - Open burner compartment access panel.
- 3 - Remove screws securing burner assembly to burner support and remove assembly. See FIGURE 35. Clean as necessary.
- 4 - Locate the ignitor under the left burners. Check ignitor spark gap with appropriately sized twist drills or feeler gauges. See FIGURE 36.
- 5 - Check the alignment of the ignitor and the sensor as shown in FIGURE 37 and TABLE 19.
- 6 - Replace burners and screws securing burner.
- 7 - Replace access panel.
- 8 - Restore electrical power and gas supply. Follow lighting instructions attached to unit and use inspection port in access panel to check flame.

⚠ WARNING



Danger of explosion. Can cause injury or death. Do not overtighten main burner mounting screws. Snug tighten only.

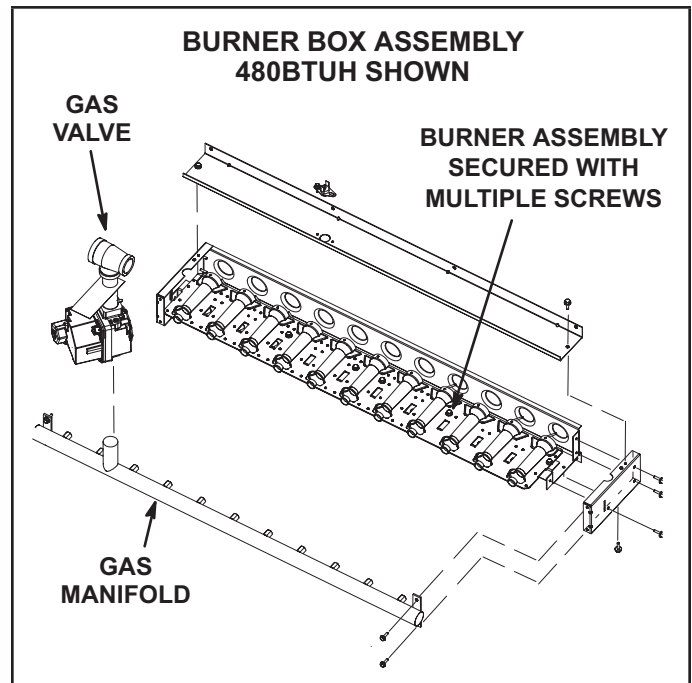

FIGURE 35

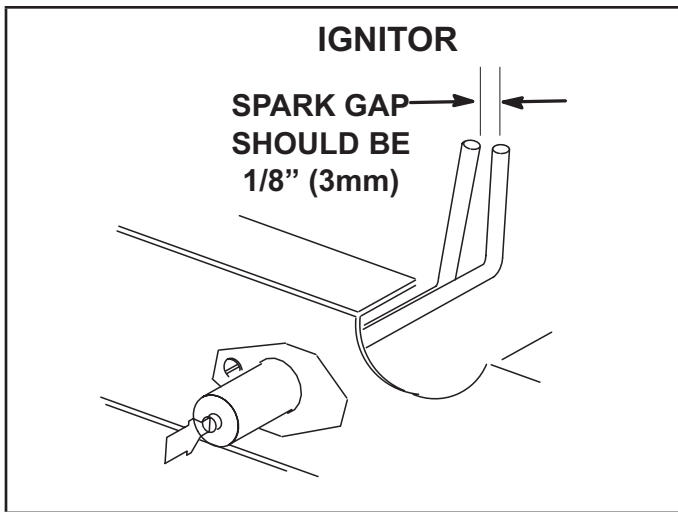

FIGURE 36

TABLE 19

Dimension	Unit Btuh Input	Length - in. (mm)	
		Ignitor	Sensor
A	260K	7-3/4 (197)	11 (279)
B	360K	5 (127)	5-1/2 (140)
C	480K	2-1/4 (57)	2-3/4 (70)

D-Combustion Air Inducer (Gas Units)

A combustion air proving switch checks combustion air inducer operation before allowing power to the gas controller. Gas controller will not operate if inducer is obstructed.

Under normal operating conditions, the combustion air inducer wheel should be checked and cleaned prior to the heating season. However, it should be examined periodically during the heating season to establish an ideal cleaning schedule. With power supply disconnected, the condition of the inducer wheel can be determined by looking through the vent opening.

Clean combustion air inducer as follows:

- 1 - Shut off power supply and gas to unit.
- 2 - Disconnect pressure switch air tubing from combustion air inducer port.
- 3 - Remove and retain screws securing combustion air inducer to flue box. Remove and retain two screws from bracket supporting vent connector. See FIGURE 38.
- 4 - Clean inducer wheel blades with a small brush and wipe off any dust from housing. Clean accumulated dust from front of flue box cover.
- 5 - Return combustion air inducer motor and vent connector to original location and secure with retained screws. It is recommended that the combustion air inducer gasket be replaced during reassembly.
- 6 - Clean combustion air inlet louvers on heat access panel using a small brush.

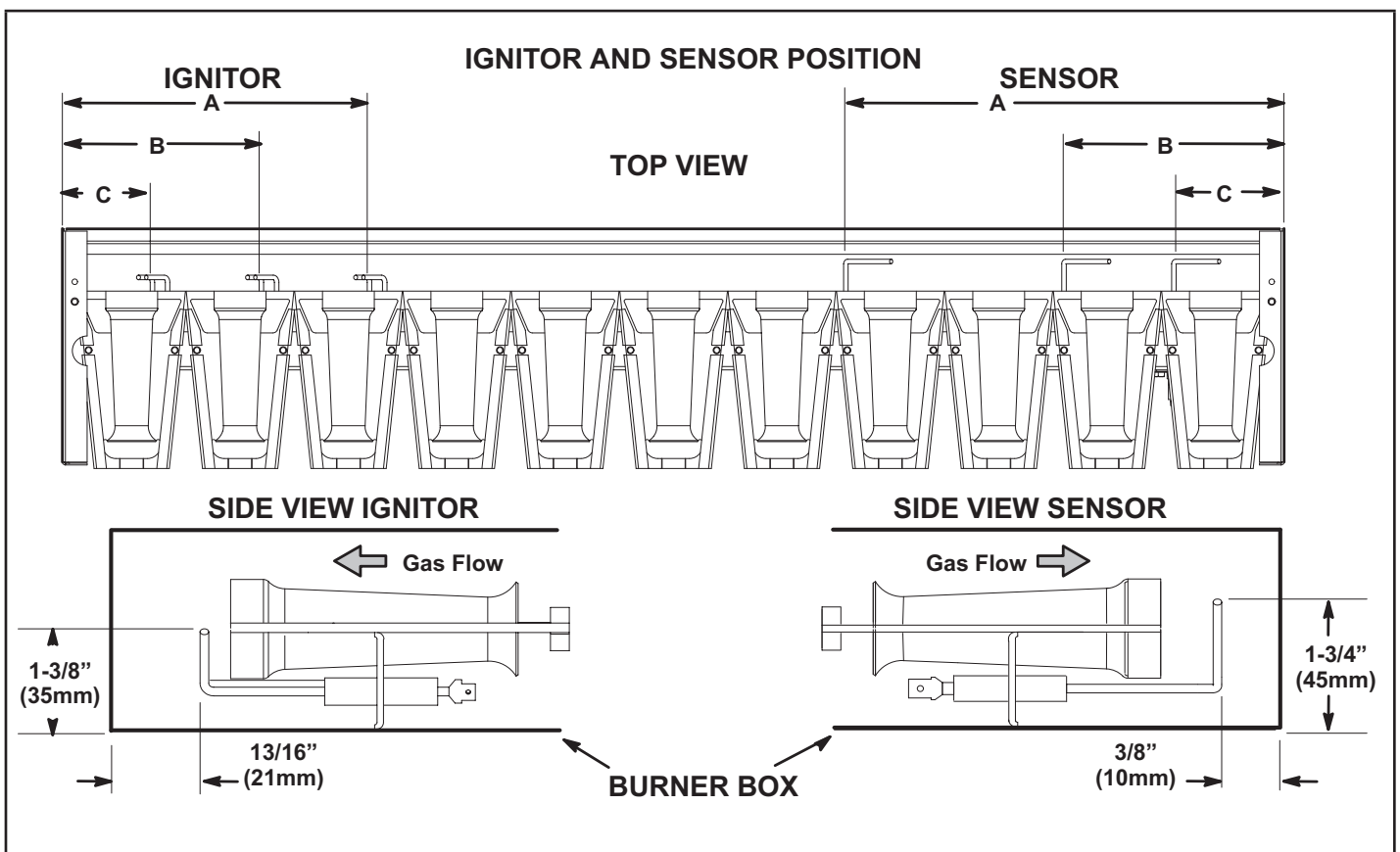

FIGURE 37

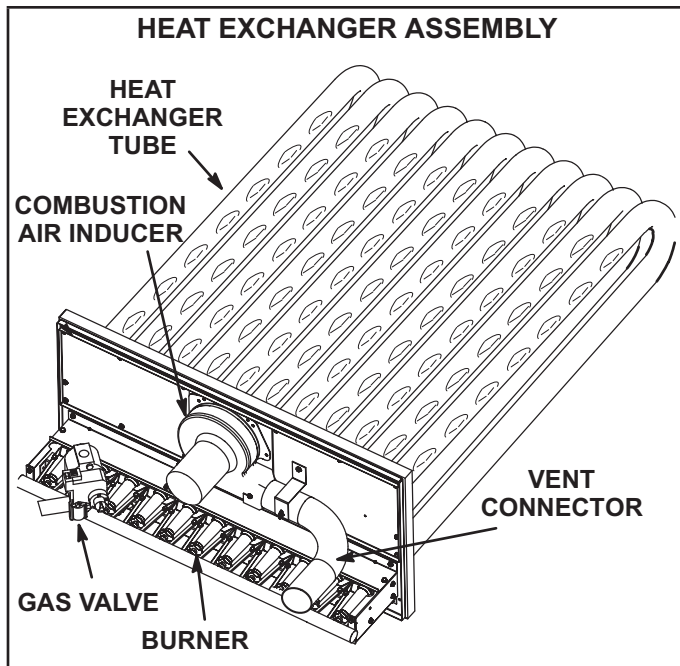

FIGURE 38

E-Flue Passageway and Flue Box (Gas Units)

- 1 - Remove combustion air inducer assembly as described in section D.
- 2 - Remove flue box cover. Clean with a wire brush as required.
- 3 - Clean tubes with a wire brush.
- 4 - Reassemble the unit. The flue box cover gasket and combustion air inducer gasket should also be replaced during reassembly.

F-Indoor Coil

Inspect and clean coil at beginning of each cooling season. Clean using mild detergent or commercial coil cleaner. Flush coil and condensate drain with water taking care not to get insulation, filters and return air ducts wet.

G-Supply Air Blower Wheel

Annually inspect supply air blower wheel for accumulated dirt or dust. Turn off power before attempting to remove access panel or to clean blower wheel.

H-Outdoor Coil

Clean outdoor coil annually with detergent or commercial coil cleaner and inspect monthly during the cooling season. Access panels are provided on front and back of outdoor section.

J-Indoor Air Quality (CO₂) Sensor

The Unit Controller uses input (CO₂ levels) from the optional sensor to adjust dampers and maintain specified amounts of fresh outdoor air. See FIGURE 39.

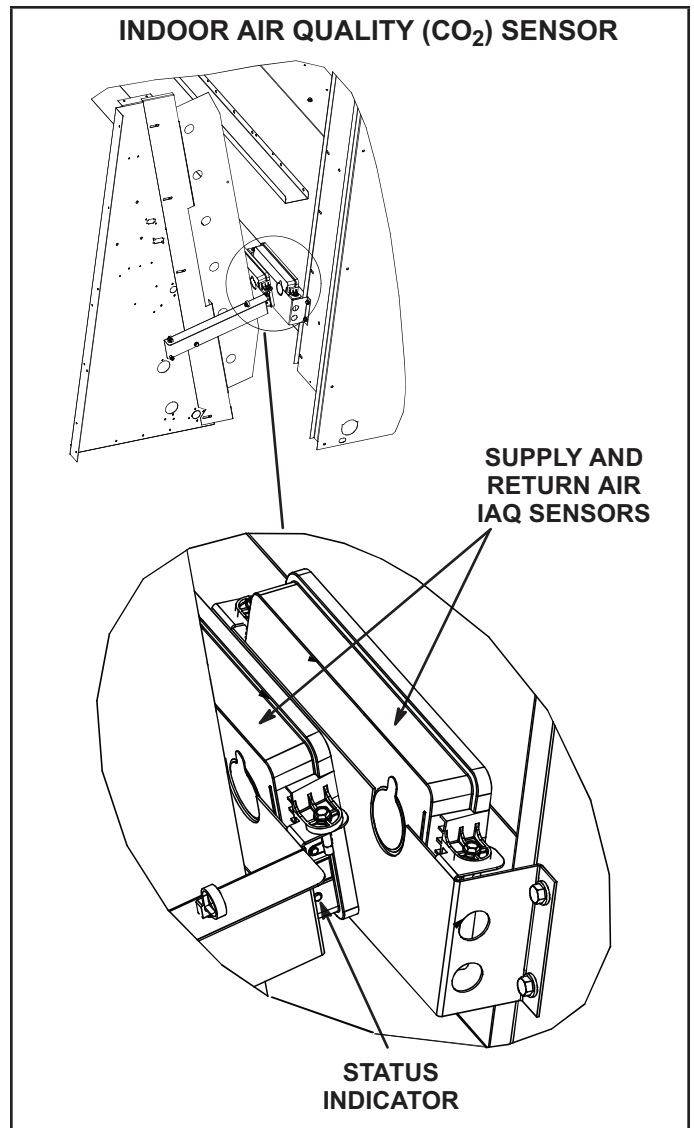

FIGURE 39

K-Needlepoint Bipolar Ionizer

The optional, brush-type ionizer produces positive and negative ions to clean air and reduce airborne contaminants. The ionizer was designed to be low maintenance. The device should be checked semi-annually to confirm the brushes are clean for maximum output. The ionizer is located behind the filters. See FIGURE 40.

- 1 - Remove filters, screws securing the top and bottom of the upper filter bracket, and the wire ties the screws hold in place. See FIGURE 40.
- 2 - Disconnect the ionizer plug near the top of the filter rack.
- 3 - Pull ionizer out of unit and clean brushes.
- 4 - Replace ionizer, reconnect ionizer plug, and replace filters, screws, and wire ties.

INSTALL IONIZER

20 TON SHOWN
(5 IONIZERS)

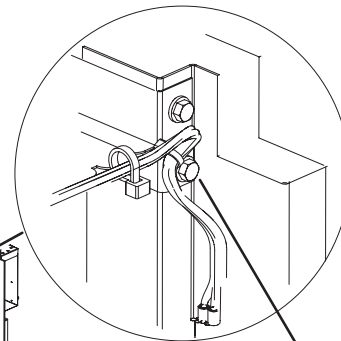

REMOVE THE SCREW
SECURING THE **TOP**
OF THE UPPER FILTER
RACK BRACKET

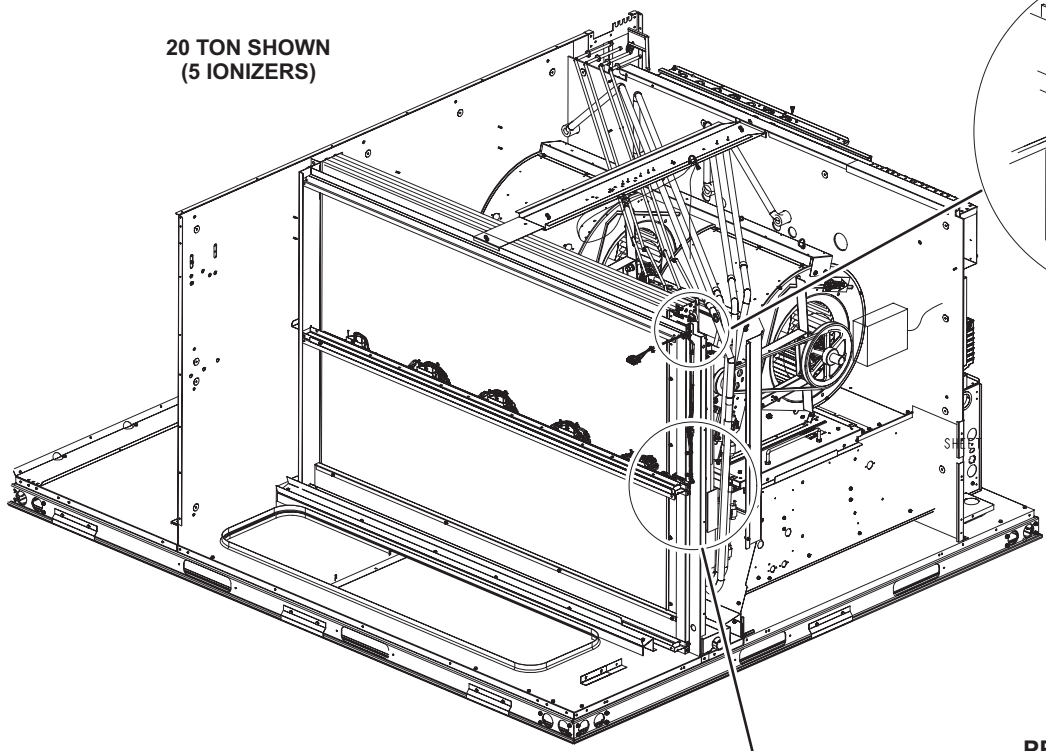

**ONE EDGE
PROTECTOR ON
IONIZER BRACKET**

INDOOR COIL

REMOVE THE
SCREW SECURING
THE **BOTTOM**
OF THE UPPER FILTER
RACK BRACKET

**TWO EDGE
PROTECTORS ON
FILTER RACK**

IONIZER
BRACKET

UPPER FILTER
BRACKET
U-CHANNEL

SLIDE IONIZER BRACKET
BETWEEN UPPER AND LOWER
FILTER BRACKET U-CHANNELS

LOWER FILTER
BRACKET
U-CHANNEL

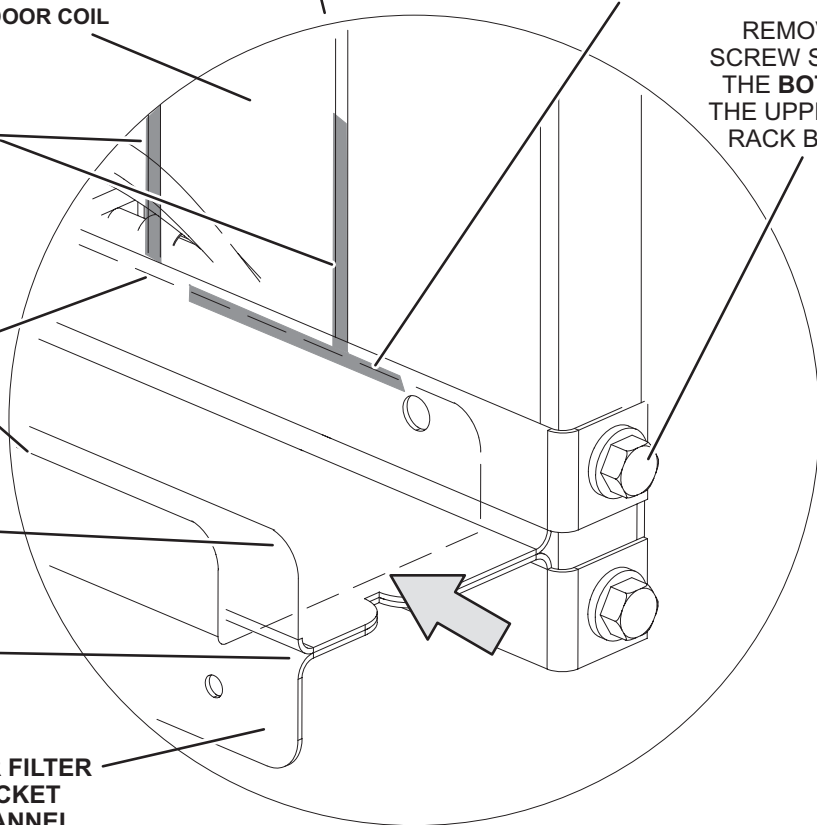

FIGURE 40

L-UVC Light (Optional)

When field-installed, use only UVC Light Kit assembly 106883-01 (21A94) with this appliance.

Factory-Installed UVC Light

When the UVC light is factory installed, the lamp is shipped in a foam sleeve. The lamp is attached to the UVC light assembly on the blower deck. Remove the lamp and install into the UVC light assembly as shown in steps 2 through 11 as follows.

Annual Lamp Replacement

⚠ WARNING

Personal Burn Hazard.

Personal injury may result from hot lamps. During replacement, allow lamp to cool for 10 minutes before removing lamp from fixture.

The lamp should be replaced every 12 months, as UVC energy production diminishes over time.

- 1 - Obtain the correct model germicidal light replacement lamp 101087-02.
- 2 - Disconnect power to the rooftop unit before servicing the UVC kit.
- 3 - Open the blower access door.
- 4 - Disconnect the UVC cable quick connects (black/white).
- 5 - Remove and retain the (3) mounting screws securing the UVC assembly. Carefully remove the complete UVC assembly out through the blower access door. See FIGURE 41.

- 6 - Allow 10 minutes before touching the lamps. Then, carefully remove the lamp splash guards (and lamp for annual replacement) from each of the lamp holders. See FIGURE 42.
- 7 - Wear cotton gloves or use a cotton cloth when handling the new lamp. Gently but firmly push in the splash guards on each end of the lamp. Align and insert the lamp with splash guard into the lamp holders of the UVC assembly until each end clicks into place.

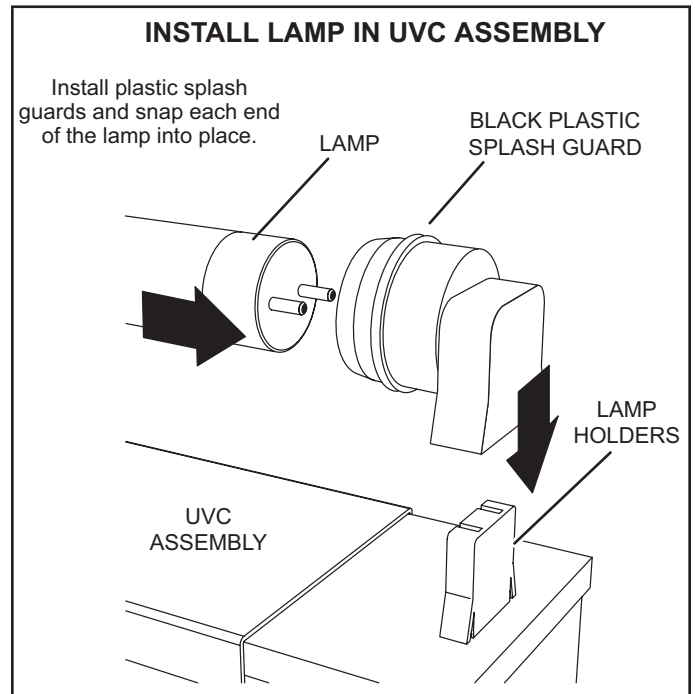

FIGURE 41

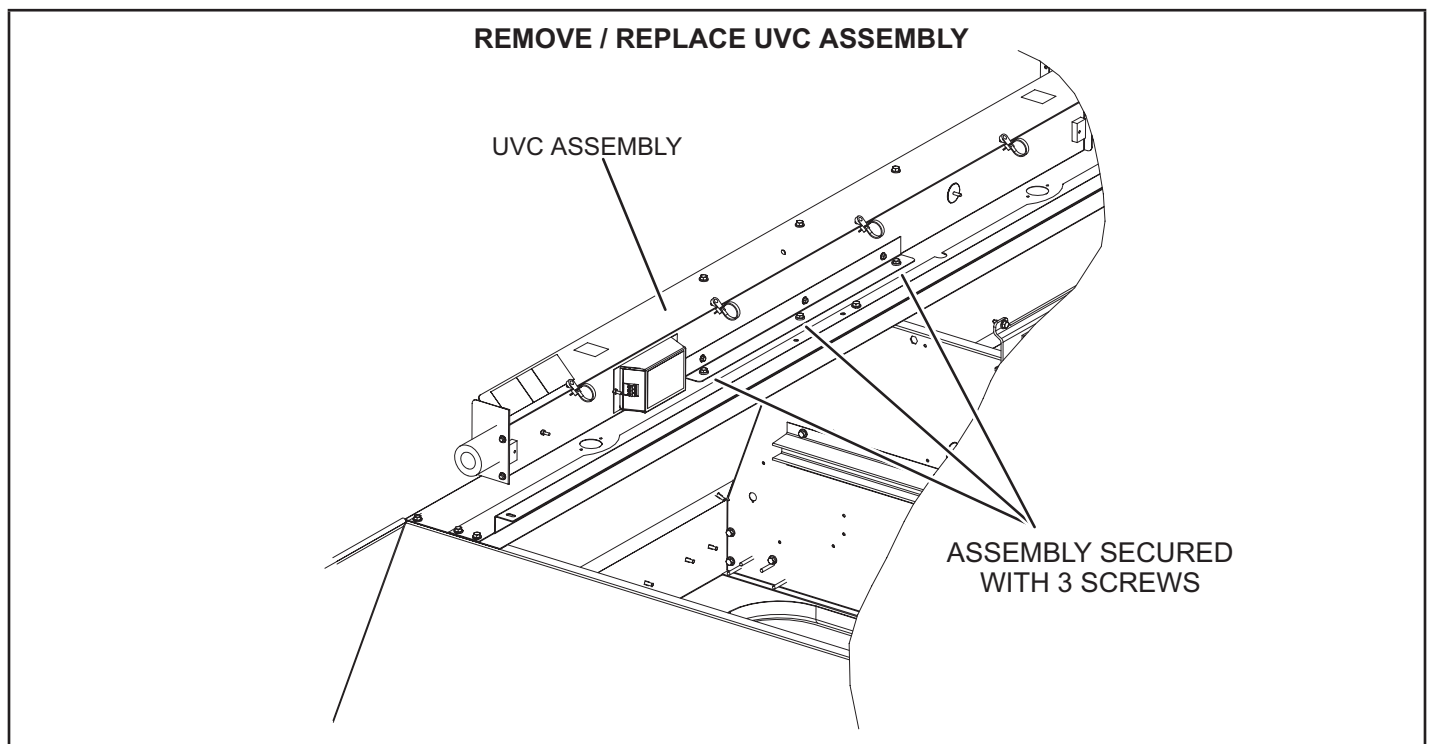

FIGURE 42

8 - Carefully place the UVC assembly on the blower deck. Line up the mounting holes on the UVC assembly with the mounting holes on the blower deck. Use the retained #10 screws to attach the UVC assembly in place.

9 - Close the blower access door.

10 -Reconnect power to the rooftop unit.

11 -Open the filter access door and look through the view port in the triangular sheet-metal panel to verify that the UVC light is on.

For all maintenance, contact a licensed HVAC technician. If UVC lamp does not come on:

1 - Check Power Wiring: Disconnect 1/4" QC (quick connects) of the UVC cable near the UVC assembly. With Power ON, use multimeter to test 110-230V at the 1/4"QC quick connects from the control panel.

2 - Check Lamp: Carefully remove the UVC assembly out of the rooftop unit. Use multimeter to test for continuity across each pair of pins at each end of the lamp.

3 - Check Lamp Installation: Make sure that lamp's pins snap properly into the lamp holder.

Lamp Disposal

NOTE - UV Lamp Contains Mercury. Dispose According to Local, State, or Federal Laws.

Proper Clean-up Technique in Case of Lamp Breakage

Wear protective gloves, eye wear and mask.

Sweep the broken glass and debris into a plastic bag, seal the bag, and dispose of properly. Contact your local waste management office for proper disposal.

Do not use a vacuum cleaner. Do not incinerate.

Maintenance

- For all maintenance, contact a qualified HVAC technician.
- Read the maintenance instructions before opening unit panels.
- Unintended use of the unit or damage to the unit housing may result in the escape of dangerous UVC radiation. UVC radiation may, even in small doses, cause harm to the eyes and skin.
- Do not operate units that are obviously damaged.
- Do not discard the triangular UVC light shield or any barriers with an ultraviolet radiation symbol.
- Do not override the door interlock switch that interrupts power to the UVC light.
- Do not operate the UVC light outside of the unit.

M-Replacement Fuses

See the following tables for the proper replacement fuse sizes.

ELECTRIC HEAT REPLACEMENT FUSES				
	Electric Heat	Qty.	Rating	
			Amp	Volt
1	E1EH0050N-1P	2	30	250
2	T1/E1EH0075AN1Y	3	25	250
3	E1EH0100N-1P	4	30	250
4	T1/E1EH0150AN1Y	3	50	250
5	T1/E1EH0225AN1Y	6	45	250
6	T1/E1EH0300N-1Y	6	60	250
7	E2EH0300N-1Y	6	60	250
8	K1EH0050A-1P	2	30	250
9	T1/E1EH0075AN1P	2	40	250
10	T1EH0100A-1P	4	30	250
11	T1/E1EH0150AN1P	4	40	250
12	T1/E1EH0225AN1P	6	40	250
13	T1/E1EH0075AN1J	3	15	600
14	T1/E1EH0150AN1J	3	20	600
15	T1/E1EH0225AN1J	3	30	600
16	T1/E1EH0300N-1J	3	40	600
17	T1/E1EH0075AN1G	3	15	600
18	T1/E1EH0150AN1G	3	25	600
19	T1/E1EH0225AN1G	3	35	600
20	T1/E1EH0300N-1G	3	50	600
21	K1/E1EH0057AN1M	3	15	600
22	K1/E1EH0115AN1M	3	20	600
23	K1EH0172AN1M	3	30	600
24	E1EH0172N-1M	3	30	600
25	K1/E1EH0230N-1M	3	40	600

TABLE 20

LDT/LHT156										
Unit Voltage			208V - 3 Ph		240V - 3 Ph		480V - 3Ph		600V - 3 Ph	
Power Exhaust Option			W / P.E.	W / O P.E.	W / P.E.	W / O P.E.	W / P.E.	W / O P.E.	W / P.E.	W / O P.E.
Diagram Key	Class	Blower HP	Amps							
F10	CC	ALL	12 A	12 A	12 A	12 A	12 A	12 A	12 A	12 A
F61	J	ALL	For F61 Fuse, see MOP Value on nameplate.							
F57	CC	ALL	-	-	-	-	7.5 A	7.5 A	10 A	10 A
F58	CC	ALL	-	-	-	-	7.5 A	7.5 A	10 A	10 A

¹ When SCCR is installed, F4 fuse is Class J.

² Fuse F61 is only used on units with SCCR installed.

TABLE 21

LDT/LHT180										
Unit Voltage			208V - 3 Ph		240V - 3 Ph		480V - 3Ph		600V - 3 Ph	
Power Exhaust Option			W / P.E.	W / O P.E.	W / P.E.	W / O P.E.	W / P.E.	W / O P.E.	W / P.E.	W / O P.E.
Diagram Key	Class	Blower HP	Amps							
F10	CC	ALL	12 A	12 A	12 A	12 A	12 A	12 A	12 A	12 A
F61	J	ALL	For F61 Fuse, see MOP Value on nameplate.							
F57	CC	ALL	-	-	-	-	7.5 A	7.5 A	10 A	10 A
F58	CC	ALL	-	-	-	-	7.5 A	7.5 A	10 A	10 A

¹ When SCCR is installed, F4 fuse is Class J.

² Fuse F61 is only used on units with SCCR installed.

TABLE 22

LDT/LHT240										
Unit Voltage			208V - 3 Ph		240V - 3 Ph		480V - 3Ph		600V - 3 Ph	
Power Exhaust Option			W / P.E.	W / O P.E.	W / P.E.	W / O P.E.	W / P.E.	W / O P.E.	W / P.E.	W / O P.E.
Diagram Key	Class	Blower HP	Amps							
F10	CC	ALL	12 A	12 A	12 A	12 A	12 A	12 A	12 A	12 A
F61 ²	J	ALL	For F61 Fuse, see MOP Value on nameplate.							
F57	CC	ALL	-	-	-	-	7.5 A	7.5 A	10 A	10 A
F58	CC	ALL	-	-	-	-	7.5 A	7.5 A	10 A	10 A

¹ When SCCR is installed, F4 fuse is Class J.

² Fuse F61 is only used on units with SCCR installed.

Factory Unit Control Settings

Use the mobile service app to adjust parameters; menu paths are shown in each table. Refer to the Unit Controller manual provided with each unit.

TABLE 23 through TABLE 25 show factory settings (in degrees, % of fan CFM, etc.). Record adjusted settings on the label located inside the compressor access panel.

When field installing optional kits and accessories, the Unit Controller must be configured to identify the option before it will function. Refer to FIGURE 43 and FIGURE 44 to determine whether the Unit Controller configuration I.D. must change. To configure the option, use MAIN MENU > SETUP > INSTALL menu path. Press SAVE until CONFIGURATION ID 1 or 2 appears depending on the option installed. Change the appropriate character in the configuration I.D. For example, when an economizer is installed using a single enthalpy sensor, change configuration I.D. 1, the second character, to "S".

TABLE 23 - 581038-01

Units With BACnet Module Settings
RTU Menu > Network Integration > Network Setup Wizard > BACnet MS/TP > See BACnet MAC Address
BACNET MAC ADDRESS:
Units With Room Sensor, CPC/LSE Gateway Settings
RTU Menu > Network Integration > Network Setup Wizard > SBUS > Set SBUS Address
LCONN ADDRESS:

TABLE 24 - 581037-01

Units With LonTalk Settings
Use menu RTU Menu > Network Integration > Network Setup Wizard > Set "LONTALK"

TABLE 25 - 581182-02

Staged Blower Parameters					
Parameter	Factory Setting			Field Setting	Description
	156H	180H	240H		
<i>NOTE - Any changes to Smoke CFM setting must be adjusted before the other CFM settings. Use SETTINGS > RTU OPTIONS > EDIT PARAMETERS</i>					
12	5200 CFM	6000 CFM	8000 CFM	CFM	Blower CFM during smoke detection
SETUP > TEST & BALANCE (can also use SETTINGS > RTU OPTIONS > BLOWER > SPEEDS)					
17	2350 CFM	2700 CFM	3600 CFM	CFM	Blower CFM during COOLING LOW operation.
14	4675 CFM	5400 CFM	7200 CFM	CFM	Blower CFM during COOLING HIGH operation.
13	6000 CFM	6000 CFM	8000 CFM	CFM	Blower CFM during HEATING operation.
18	5200 CFM	6000 CFM	8000 CFM	CFM	Blower CFM during ventilation
SETUP > TEST & BALANCE (can also use SETTINGS > RTU OPTIONS > DAMPER)					
9	0%	0%	0%	%	Damper min. position during LOW blower operation.
132	0%	0%	0%	%	Damper min. position during HIGH blower operation.
215	50%	50%	50%	%	Min. damper % for stg 1 power exhaust operation.
SETTINGS > RTU OPTIONS > EDIT PARAMETERS					
29	101%	101%	101%	%Open	
219	75%	75%	75%	%	Min. damper % for stg 2 power exhaust operation.
216	10%	10%	10%	%	Deadband % for stage 1 power exhaust operation.
220	10%	10%	10%	%	Deadband % for stage 2 power exhaust operation.
224	100	100	100	Sec	Stage 1 power exhaust off-delay in seconds.
30	70%	70%	70%	%Speed	Minimum blower speed % for stage 2 power exhaust operation.

IMPORTANT: Always refer to the white sticker titled ORIGINAL FACTORY UNIT CONFIGURATION located inside the control box area.

CONFIGURATION ID 1

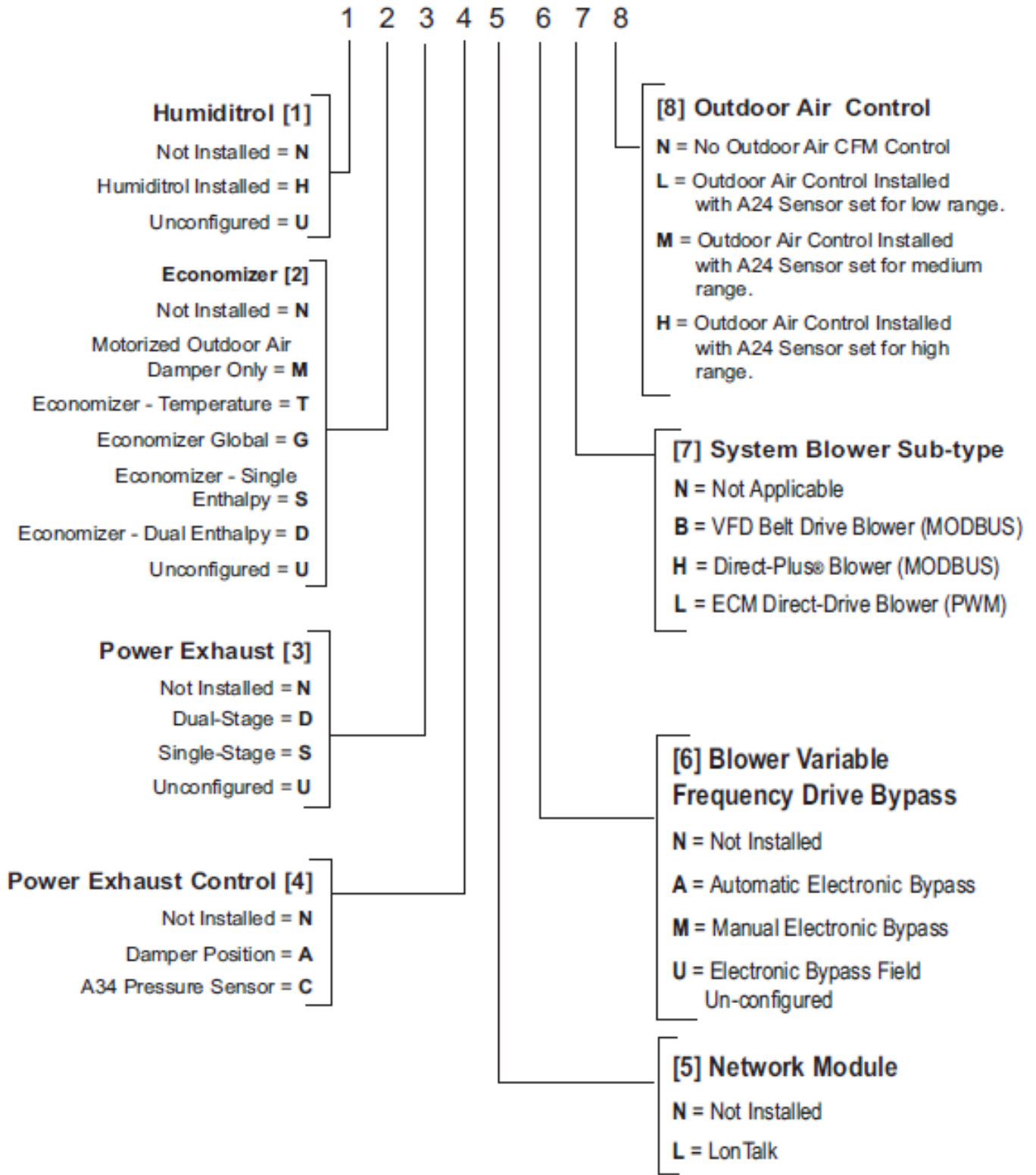
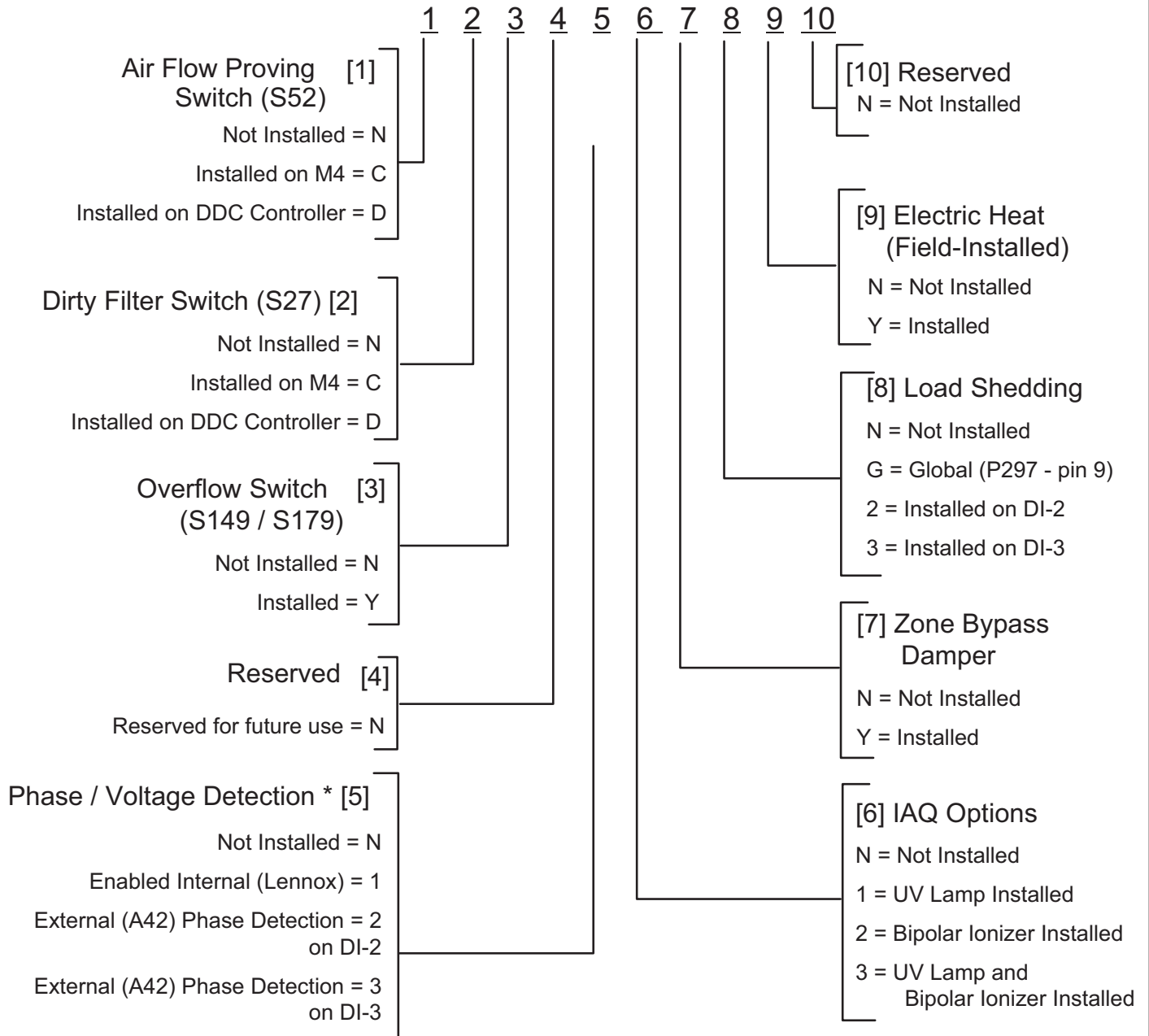

FIGURE 43

CONFIGURATION ID 2



* When phase detection and voltage monitoring is enabled and wired incorrectly, the system will go into demand hold status and restart after six minutes.

FIGURE 44

Decommissioning

Before carrying out this procedure, it is essential that the technician is completely familiar with the equipment and all its detail. It is recommended good practice that all refrigerants are recovered safely.

Prior to the task being carried out, an oil and refrigerant sample shall be taken in case analysis is required prior to re-use of recovered refrigerant. It is essential that electrical power is available before starting decommissioning.

- a) Become familiar with the equipment and its operation.
- b) Isolate system electrically.
- c) Before attempting the procedure, ensure that:
 - mechanical handling equipment is available, if required, for handling refrigerant cylinders;
 - all personal protective equipment is available and being used correctly;
 - the recovery process is supervised at all times by a competent person;
 - recovery equipment and cylinders conform to the appropriate standards.
- d) Pump down refrigerant system, if possible.
- e) If a vacuum is not possible, make a manifold so that refrigerant can be removed from various parts of the system.
- f) Make sure that cylinder is situated on the scales before recovery takes place.
- g) Start the recovery machine and operate in accordance with instructions.
- h) Do not overfill cylinders (no more than 80% volume liquid charge).
- i) Do not exceed the maximum working pressure of the cylinder, even temporarily.
- j) When the cylinders have been filled correctly and the process completed, make sure that the cylinders and the equipment are removed from site promptly and all isolation valves on the equipment are closed off.
- k) Recovered refrigerant shall not be charged into another REFRIGERATING SYSTEM unless it has been cleaned and checked.



IMPORTANT

Equipment shall be labelled stating that it has been decommissioned and emptied of refrigerant. The label shall be signed and dated. Ensure that there are labels on the equipment that state the flammability of the refrigerant used.

START-UP REPORT

Job Name: _____
 Store No. _____ Start-Up Date: _____
 Address: _____
 City: _____ State: _____
 Start-Up Contractor: _____
 Technician: _____
 Model No.: _____
 Serial No.: _____
 RTU No.: _____ Catalog No.: _____

Inspections and Checks			
Damage?	Yes	No	R454B <input type="checkbox"/>
If yes, reported to: _____			
Verify factory and field-installed accessories. Check electrical connections. Tighten if necessary. Supply voltage: L1-L2 _____ L1-L3 _____ L2-L3 _____ If unit contains a 208-230/240 volt transformer: Check primary transformer tap <input type="checkbox"/> Transformer secondary voltage: _____			

Cooling Checks												
Compressor Rotation <input type="checkbox"/> Ambient Temp. _____ Return Air Temp. _____ Supply Air Temp. _____												
	Compressor Amps			Compressor Volts			Pressures		Condenser Fan Amps			CC Heater Amps
	L1	L2	L3	L1-L2	L1-L3	L2-L3	Disch.	Suct.	L1	L2	L3	L1
1												
2												
3												
4												

Blower Checks			
Pulley/Belt Alignment <input type="checkbox"/>	Blower Rotation <input type="checkbox"/>		
Set Screws Tight <input type="checkbox"/>	Belt Tension <input type="checkbox"/>		
Nameplate Amps: _____		Volts: _____	
Motor	Amps	Volts	
	L1 _____	L1-L2 _____	
	L2 _____	L1-L3 _____	
	L3 _____	L2-L3 _____	

Heating Checks - Electric							
Return Air Temp.: _____ Supply Air Temp.: _____							
Limits Operate: <input type="checkbox"/>							
	Amps						
	L1	L2	L3		L1	L2	L3
1				10			
2				11			
3				12			
4				13			
5				14			
6				15			
7				16			
8				17			
9				18			

Accessory Checks		
Power Exhaust Amps		
1 _____	2 _____	None <input type="checkbox"/>
Economizer Operation		
Min. Pos. <input type="checkbox"/>	Motor travel full open/close <input type="checkbox"/>	