

PACKAGED HEAT PUMP

LHT

ENLIGHT ROOFTOP UNITS

High Efficiency | Lennox® CORE Controller | **R-454B** | 60Hz

**COMMERCIAL
PRODUCT SPECIFICATIONS (EHB)**



25 Tons

Net Cooling Capacity - 274,000 Btuh

Net Heating Capacity - 270,000 Btuh

Optional Electric Heat - 30 to 90 kW

ENLIGHT



SMARTWIRE™ SYSTEM



MODEL NUMBER IDENTIFICATION

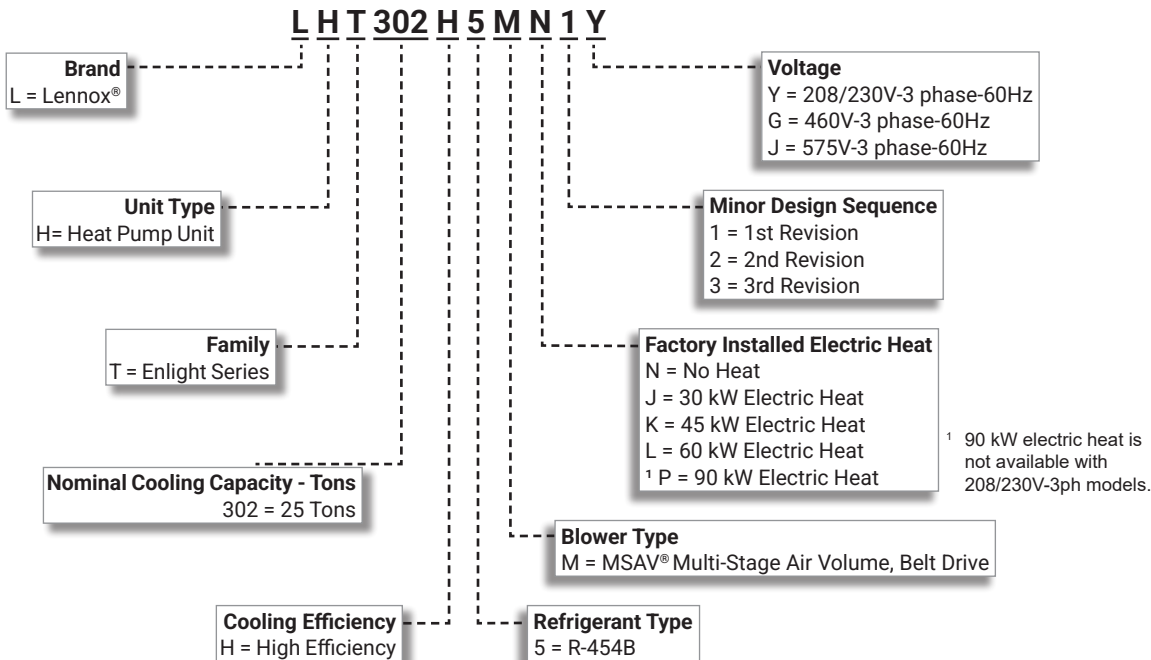

FEATURE HIGHLIGHTS

Enlight rooftop units featuring the Lennox® CORE Control System create a bright future through a highly energy-efficient and environmentally sustainable design. Comprehensive configurations meet a wide range of applications, making it the most flexible product line Lennox has to offer.

1. Scroll Compressors
2. Copper Tube Outdoor Coil
3. Thermal Expansion Valves
4. Filters/Driers
5. Outdoor Coil Fan Motors
6. Heavy Gauge Steel Cabinet
7. Hinged Access Panels
8. MSAV® Multi-Stage Air Volume Blower
9. Electric Heat (option)
10. Air Filters
11. Lennox® CORE Control System
12. Economizer (option)
13. Downflow Barometric Relief Dampers (option)
14. Power Exhaust

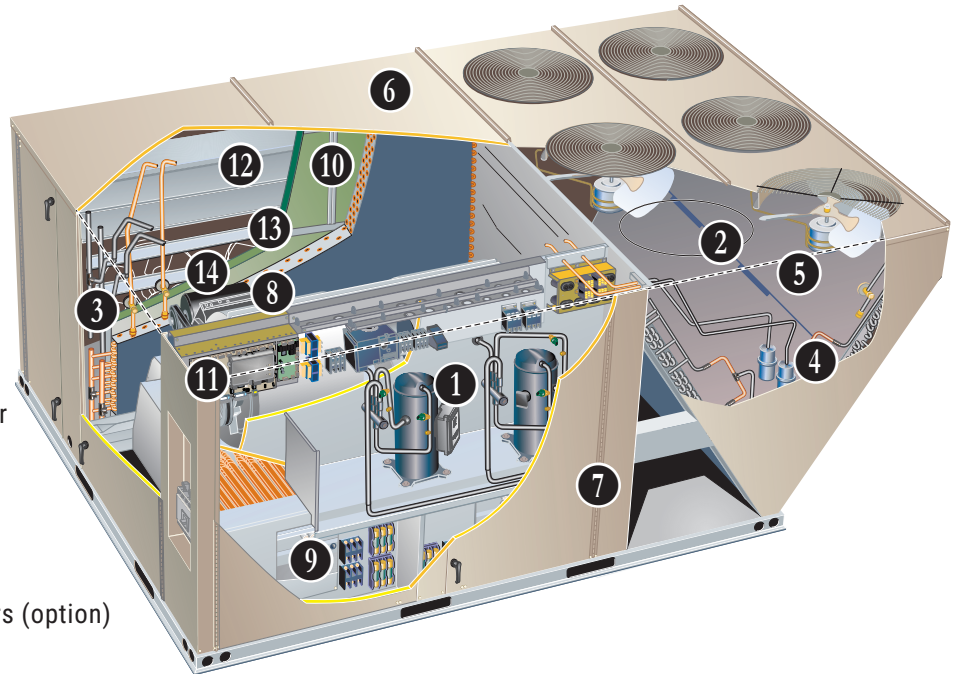

CONTENTS

Approvals And Warranty	3
Blower Data	26
Control System	9
Dimensions	36
- Accessories	37
- Unit	36
Electrical Accessories - Disconnects	32
Electrical Data	30
Electric Heat Data	31
Features And Benefits	4
Model Number Identification	1
Optional Conventional Temperature Control Systems	14
Options / Accessories	20
Outdoor Sound Data	35
Specifications	24
Unit Clearances	33
Weight Data	35

APPROVALS AND WARRANTY

APPROVALS

- All models tested at conditions included in AHRI Standard 340/360-2022
- ETL and CSA listed
- All models are ASHRAE 90.1-2025 compliant
- All models meet DOE 2023 energy efficiency standards
- All models are listed to UL 60335-1 and UL 60335-2-40 and meet the Refrigerant Detection and Dissipation Requirements
- Components are bonded for grounding to meet safety standards for servicing required by ETL, NEC and CEC
- All models meet California Code of Regulations, Title 24 and ASHRAE 90.1-2025 Section 6.4.3.10 requirements for staged airflow
- All models have been sound tested in accordance with test conditions included in AHRI Standard 270 or 370
- ISO 9001 Registered Manufacturing Quality System
- All models have FSA approval and are compliant with standard ASCE 7-22 (ASD) and the Florida Building Code Eighth Edition (2023)
- Units are charged with virgin refrigerant to comply with NYCRR Part 494
- All models are fully charged and run tested to verify unit operation and functionality

WARRANTY

- Compressors - Limited five years
- Lennox® CORE Unit Controller - Limited three years
- Variable-Frequency Drive (VFD) - Limited five years
- High Performance Economizers (optional) - Limited five year
- All other covered components - Limited one year

FEATURES AND BENEFITS

COOLING/HEATING SYSTEM

- Designed to maximize sensible and latent cooling performance at design conditions
- Mechanical cooling operates from 0°F to 125°F
- Mechanical heating operates at ambient temperatures above -15°F

NOTE - When a call for heating is initiated at ambient temperatures above -4°F, unit will attempt to satisfy demand with mechanical heating down to -15°F ambient.

If a call for heating is initiated at or below -4°F, the unit will lockout mechanical heating (compressors) and use optional electrical heat to satisfy demand.

R-454B Refrigerant

- Low GWP (Global Warming Potential)
- Zero ODP (Ozone Depletion Potential)
- Low Toxicity/Lower Flammability - A2L
- Unit is factory pre-charged

1 Scroll Compressors

- System consists of one two-stage compressor and one single-stage scroll compressor
- Resiliently mounted on rubber grommets for quiet operation

Compressor Crankcase Heaters

- Protects against refrigerant migration that can occur during low ambient operation or during extended off cycles

2 Coil Construction

- Copper tube construction
- Enhanced rippled-edge aluminum fins
- Flared shoulder tubing connections
- Silver soldered construction
- Factory leak tested

Evaporator Coil

- Copper tube construction
- Enhanced rippled-edge aluminum fins
- Flared shoulder tubing connections
- Silver soldered construction
- Factory leak tested
- Cross-row circuiting with rifled tubing

3 Thermal Expansion Valves

- Ensures optimal performance throughout the application range
- Removable element head

4 Filter/Driers

- High capacity filter/drier protects the system from dirt and moisture

5 Reversing Valve

- 4-way interchange reversing valve rapidly changes the direction of refrigerant flow resulting in quick changeover from cooling to heating and vice versa

High Pressure Switches

Protects the compressor from overload conditions such as dirty condenser coils, blocked refrigerant flow or loss of outdoor fan operation

Low Pressure Switches

- Protects the compressors from low pressure conditions such as low refrigerant charge or low/no airflow

Indoor Coil Freeze Protection

- Protects the indoor coil from damaging ice build-up due to conditions such as low/no airflow, or low refrigerant charge

Antimicrobial Condensate Drain Pan

- Composite pan, sloped to meet drainage requirements per ASHRAE 62.1
- Antimicrobial additive prevents growth of mold and mildew, which improves indoor air quality and reduces drain line blockage
- Side drain connections

NOTE - Stainless steel drain pan available as a factory installed option.

6 Outdoor Coil Fan Motors

- Thermal overload protected
- Totally enclosed
- Permanently lubricated ball bearings
- Shaft up
- Wire basket mount

Outdoor Coil Fans

- PVC coated fan guard furnished

Required Selections

Cooling Capacity

- Specify nominal cooling capacity

Options/Accessories

Factory or Field Installed

Drain Pan Overflow Switch

- Monitors condensate level in drain pan
- Shuts down unit if drain becomes clogged

Stainless Steel Drain Pan

- Non-corrosive drain pan

Field Installed

Condensate Drain Trap

- Available in copper or PVC

FEATURES AND BENEFITS

LOW GWP REFRIGERANT DETECTION SYSTEM (RDS)

- Complies with UL 60335-2-40 approved standard
- Required for all systems using R-454B refrigerant
- Factory installed on all units
- Consists of a refrigerant detection sensor(s) and a mitigation control
- Ensures safe operation for systems equipped with R-454B refrigerant
- Sensor(s) monitors indoor coil area for R-454B refrigerant
- If R-454B refrigerant is detected the refrigerant detection system will prevent compressor and heating operation until R-454B refrigerant is no longer detected
- Refrigeration detection system energizes blower if any R-454B refrigerant is detected to mitigate any concentrations of refrigerant from the unit and the system

CABINET

7 Construction

- Heavy-gauge steel panels
- Full perimeter heavy-gauge galvanized steel base rail
- Base rails have rigging holes
- Three sides of the base rail have forklift slots
- Raised edges around duct and power entry openings in the bottom of the unit for water protection

Airflow Choice

- Units are shipped in downflow (vertical) return air flow configuration

NOTE - Units can be field converted to horizontal air flow with optional Horizontal Return Air Panel Kit and Horizontal Roof Curb.

Power Entry

- Electrical lines can be routed through the unit base or through horizontal access knock-outs

Exterior Panels

- Constructed of heavy-gauge, galvanized steel
- Textured pre-paint with polyurethane finish
- Cyclic salt fog and UV exposure up to 1,680 hours per ASTM D5894

Insulation

- Fully insulated with non-hygroscopic fiberglass insulation (conditioned areas)
- Unit base is fully insulated
- Base insulation serves as an air seal to the roof curb, eliminating the need to add a seal during installation

8 Hinged Access Panels

- Filter section
- Blower section
- Heating section
- Compressor/controls section
- Panel seals and quarter-turn latching handles provide a tight air and water seal

Options/Accessories

Factory Installed

Corrosion Protection

- Completely flexible immersed coating
- Electrodeposited dry film process
- AST ElectroFin E-Coat
- Meets Mil Spec MIL-P-53084, ASTM B117 Standard Method Salt Spray Testing
- Indoor Corrosion Protection:
 - Coated coil
 - Painted blower housing
 - Painted base
- Outdoor Corrosion Protection:
 - Coated coil
 - Painted outdoor base

Factory or Field Installed

Combination Coil/Hail Guards

- Heavy gauge steel frame
- Painted to match cabinet
- Expanded metal mesh protects outdoor coil

Field Installed

Horizontal Return Air Panel Kit

- Required for horizontal applications with Horizontal Roof Curb
- Contains panel with return air opening for field replacement of existing unit panel and panel to cover bottom return air opening in unit
- See dimension drawings

Burglar Bars

- Heavy gauge galvanized frame
- Fully welded
- 3/4 in. bar meets ASTM specification
- Frame meets ASTM A446, A525, A526 and A527 specification
- Burglar bars designed to fit ductwork

FEATURES AND BENEFITS

BLOWER

- A wide selection of supply air blower options are available to meet a variety of airflow requirements

Motor

- Overload protected
- Ball bearings
- Belt drive motors are offered on all models and are available in several different sizes to maximize air performance

NOTE - All blower motors 5 hp and above meet minimum energy efficiency standards in accordance with the Energy Independence and Security Act (EISA).of 2007

9 Supply Air Blower

- Forward curved blades
- Double inlet
- Blower wheel statically and dynamically balanced
- Ball bearings
- Adjustable pulley (allows speed change)
- Blower assembly slides out of unit for servicing
- Grease fittings furnished

Blower Proving Switch

- Monitors blower operation, shuts down unit if blower fails

MSAV® Multi-Stage Air Volume

- MSAV® Multi-Stage Air Volume stages the amount of airflow according to compressor stages, heating demand, ventilation demand or smoke alarm
 - Utilizes a Variable Frequency Drive (VFD) to stage the supply air blower airflow
 - VFD alters the frequency and voltage of the power supply to the blower to control blower speed
- The amount of airflow for each stage can be set according to a parameter in the Lennox® CORE Unit Controller
 - Unit is shipped from the factory with preset airflows
 - If equipped with the optional Bypass Control the MSAV® Multi-Stage Air Volume features automatic electronic bypass control of the VFD
 - In case of a VFD malfunction, a VFD alarm is generated by the Lennox® CORE Unit controller
 - Unit controller will automatically switch to full blower speed if a VFD alarm is generated

NOTE - Units equipped a Variable Frequency Drive (VFD) are designed to operate on balanced, three-phase power. Operating units on unbalanced three-phase power will reduce the reliability of all electrical components in the unit. Unbalanced power is a result of the power delivery system supplied by the local utility company. Factory-installed inverters are sized to drive blower motors with an equivalent current rating using balanced three-phase power. If unbalanced three-phase power is supplied; the installer must replace the existing factory-installed inverter with an inverter that has a higher current rating to allow for the imbalance. Refer to the installation instructions for additional information and replacement information.

Ordering Information

- Specify motor horsepower and drive kit number when base unit is ordered

Options/Accessories

Factory Installed

Supply VFD Blower Bypass Control

- Allows unit to operate as a constant air volume (CAV) unit in case of variable frequency drive (VFD) failure

NOTE - Supply VFD Blower Bypass Control is not available with High Static Power Exhaust.

Field Installed

Blower Belt Auto-Tensioner

- Provides proper tension to belt drive blower belt without the need for regular adjustments
- Maintains airflow and proper performance

FEATURES AND BENEFITS

ELECTRICAL

NOTE - All units include terminal block and fuse block in power entry junction box for single power entry application.

SmartWire™ System

- Keyed and color-coded wiring connectors prevent miswiring
- Wire coloring scheme is standardized across all models
- Each connection is intuitively labeled to make troubleshooting and servicing quick and easy

Electrical Plugs

- Positive connection electrical plugs connect common accessories or maintenance parts for easy removal or installation

Phase/Voltage Detection

- Monitors power supply to assure phase is correct at unit start-up
- If phase is incorrect, the unit will not start and an alarm code is reported to the unit controller
- Protects unit from being started with incorrect phasing which could lead to issues such as compressors running backwards
- Voltage detection monitors power supply voltage to assure proper voltage
- If voltage is not correct (over/under voltage conditions) the unit will not start and an alarm code is reported to the unit controller

Required Selections

Voltage Choice

- Specify when ordering base unit

Options/Accessories

Factory Installed

Circuit Breakers

- HACR type
- Overload and short circuit protection
- Factory wired and mounted in the power entry panel
- Current sensitive and temperature activated
- Manual reset

Short-Circuit Current Rating (SCCR)

- Higher short-circuit protection up to 100kA

NOTE - Disconnect Switch not available with higher SCCR option. SCCR option only available with factory installed electric heat.

Factory or Field Installed

Disconnect Switch

- Accessible outside of unit
- Spring loaded weatherproof cover furnished

10 Electric Heat

- Helix wound nichrome elements
- Individual element limit controls
- Wiring harness
- Unit fuse block
- See Options/Accessories tables for ordering information

GFI Service Outlets (2)

- 115V ground fault circuit interrupter (GFCI) type options:
 - Factory installed and wired, unit powered
 - Factory installed, non-powered, field wired
 - Field installed, non-powered, field wired

Field Installed

GFI Weatherproof Cover

- Single-gang cover
- Heavy-duty UV-resistant polycarbonate case construction
- Hinged base cover with gasket

FEATURES AND BENEFITS

INDOOR AIR QUALITY

11

Air Filters

- Disposable 2 inch MERV 4 filters furnished as standard

Options/Accessories

Factory or Field Installed

Healthy Climate® High Efficiency Air Filters

- Disposable MERV 8 or MERV 13 (Minimum Efficiency Reporting Value based on ASHRAE 52.2) efficiency 2-inch pleated filters
- **Replacement Filter Media Kit With Frame**
- Replaces existing pleated filter media
- Includes washable metal mesh screen and metal frame with clip for holding replaceable non-pleated filter

Field Installed

Healthy Climate® High Efficiency MERV 16 Air Filters

- Disposable MERV 16 (Minimum Efficiency Reporting Value based on ASHRAE 52.2) efficiency 2-inch pleated filters

Indoor Air Quality (CO₂) Sensors

- Monitors CO₂ levels
- Reports to the Lennox® CORE Control, which adjusts economizer dampers as needed

CONTROL SYSTEM

LENNOX® CORE CONTROL SYSTEM

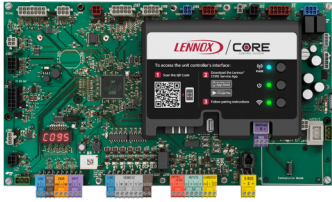

- 12 The Lennox® CORE Control System is designed to accelerate equipment install and service. Standard with all Enlight rooftop units, control system integrates key technologies that lower installation costs, drive system efficiency, and protect your investments.

The Lennox® CORE Unit Controller is a microprocessor-based controller that provides flexible control of all unit functions.

CORE Mobile Service App

- Guided Setup with progress indicators, detailed help, and exportable summaries to manage simple, trouble-free setup, reducing commissioning times
- Enhanced Test Functionality provides real-time sensor readings, trending, and reports that enable easy troubleshooting
- Ability to set and configure parameters of the CORE Control System to manage sequence of operation
- Economizer test function ensures economizer is operating correctly



Additional Features:

- Built-In 7-Segment Display shows Unit Status and active alarms for easy troubleshooting
- Buttons for test and clearing delays
- SmartWire™ System with keyed and removable screw terminals ensure correct field wiring
- Built-in BACnet MS/TP and IP allow open integration to building management systems.
- Two-port Ethernet Switch enables daisy chaining for BACnet IP and automatic firmware updates

NOTE - Unit Internet Connection required.

- Profile setup copies key settings between units with the same configuration to reduce setup time
- USB port allows a technician to download and transfer unit information to help verify service was performed
- USB software updates on the Lennox® CORE Unit Controller enhance functionality without the need to change components
- Unit Controller Software

Configurable Built-In Functions

- Discharge Air Cooling Control
- Up to three distinct Cooling Airflows in Thermostat Mode
- Programmable independent heating, ventilation and cooling blower speeds

- Discharge Air Heating Control
- Economizer Control Options (See Economizer / Exhaust Air / Outdoor Air sections)
- Exhaust Fan Control Modes for fresh air damper position
- Configurable Morning Warm-up
- Night Setback Mode
- Fresh Air Tempering for Improved Ventilation
- Demand Control Ventilation
- Low Ambient Controls for operation down to 0°F
- Humiditrol® Operation
- Enhanced Dehumidification (Latent Demand Control without hot gas reheat)

Component Protection / Unit Safeguards:

- Compressor Time-Off Delay
- Adjustable Blower On/Off Delay
- Return Air Temperature Limit Control
- Safety Switch Input allows Controller to respond to a external safety switch trip
- Service Relay Output
- Thermostat Bounce Delay
- Smoke Alarm Mode has four choices (unit off, positive pressure, negative pressure, purge)
- "Strike Three" Protection
- Gas Valve Time Delay Between First and Second Stage
- Minimum Compressor Run Time

Control Methods / Interfaces:

- DDC and 24V Thermostat
- BACnet MS/TP and IP
- LONTalk (Factory and Field Option)
- Lennox S-BUS
- Zone Temperature Sensor Input
- Dehumidistat and Humidity Sensor Inputs
- Indoor Air Quality Inputs (2)
- Built-in Control Parameter Defaults
- Permanent Diagnostic Code Storage
- Field Adjustable Control Parameters (Over 200 settings)
- Multiple Configurable Digital Inputs
- LED Indicators
- PC Interface connects the Lennox® CORE Unit Controller to a PC with the Lennox Unit Controller Software

NOTE - Lennox® CORE Control System features vary with the type of rooftop unit in which the control is installed.

CONTROL SYSTEM

LENNOX® CORE CONTROL SYSTEM (continued)

Controls Options

Factory or Field Installed

Dirty Filter Switch

- Senses static pressure increase and issues alarm if necessary

Fresh Air Tempering

- Used in applications with high outside air requirements
- Controller energizes the first stage heat as needed to maintain a minimum supply air temperature for comfort, regardless of the thermostat demand
- When ordered as a factory option, sensor ships with the unit for field installation

Smoke Detector

- Photoelectric type
- Installed in supply air section, return air section or both sections
- Available with power board and single sensor (supply or return) or power board and two sensors (supply and return)
- Power board located in unit control compartment

Commercial Control Systems

Interoperability via BACnet® or LonTalk® Protocols

- Communication compatible with third-party automation systems that support the BACnet Application Specific Controller device profile, LonMark® Space Comfort Controller functional profile, or LonMark Discharge Air Controller functional profile

Field Installed

Thermostats and Room Sensors

- Control system and thermostat options, see page 14

OPTIONS / ACCESSORIES

ECONOMIZER

- Economizer operation is set and controlled by the Lennox® CORE unit controller
- Simple plug-in connections from economizer to unit controller for easy installation
- All Enlight rooftop units are equipped with factory installed CEC Title 24 approved sensors for outside, return and discharge air temperature monitoring

NOTE - Optional sensors may be used instead of unit sensors to determine whether outdoor air is suitable for free cooling. See Options/Accessories table.

Factory or Field Installed

13 High Performance Economizer

- Approved for California Title 24 building standards
- Low leakage dampers are Air Movement and Control Association International (AMCA) Class 1A Certified - Maximum 3 CFM per sq. ft. leakage at 1 in. w.g.
- ASHRAE 90.1 and IECC compliant
- Outdoor Air Hood with mist elimination is included when economizer is factory installed and is furnished with economizer when ordered for field installation

NOTE - Downflow or horizontal economizer applications require optional Downflow or Horizontal Barometric Relief Dampers with Exhaust Hood.

- Linked damper action
- High torque 24-volt fully-modulating spring return damper motor
- Return air and outdoor air dampers
- Plug-in connections to unit

NOTE - High Performance Economizers are not approved for use with enthalpy controls in Title 24 applications.

NOTE - The Free Cooling setpoint for Title 24 applications must be set based on the Climate Zone where the system is installed. See Section 140.4 "Prescriptive Requirements for Space Conditioning Systems" of the California Energy Commission's 2022 Building Energy Efficiency Standards.

NOTE - Refer to Installation Instructions for complete setup information.

OPTIONS / ACCESSORIES

ECONOMIZER (continued)

Differential Sensible Control

- Factory setting
- Uses outdoor air and return air sensors that are furnished with the unit
- The Lennox® CORE unit controller compares outdoor air temperature with return air
- When the outdoor air is below the configured setpoint and cooler than return air, the controller activates the economizer

NOTE - Differential Sensible Control can be configured in the field to provide Offset Differential Sensible Control or Single Sensible Control.

NOTE - In Offset Differential Sensible Control mode, the economizer is enabled if the temperature differential (offset) between outdoor air and return air reaches the configured setpoint. In Single Sensible Control mode, the economizer is enabled when outdoor air temperature falls below the configured setpoint.

Global Control

- The unit controller communicates with a DDC system with one global sensor (enthalpy or sensible)
- Determines whether outside air is suitable for free cooling on all units connected to the control system
- Sensor must be field provided

NOTE - Global control with enthalpy is not approved for Title 24 applications.

Factory or Field Installed

Single Enthalpy Temperature Control (Not for Title 24)

- Outdoor air enthalpy sensor enables Economizer if the outdoor enthalpy is less than the setpoint of the control

Differential Enthalpy Control (Not for Title 24)

- Order two Single Enthalpy Controls
- One is field installed in the return air section
- One is installed in the outdoor air section
- Allows the economizer control to select between outdoor air or return air, whichever has lower enthalpy

Field Installed

Outdoor Air CFM Control

- Maintains constant outdoor air volume levels on the supply air fan and varying unit airflows
- Velocity sensor located in the rooftop unit outdoor air section, the Lennox® CORE unit controller changes the Economizer position to help minimize the effect of supply fan speed changes on outdoor air volume levels
- Setpoint for outdoor air volume is established by field testing

NOTE - Not available with Demand Control Ventilation (CO₂ Sensor) or Building Pressure Control.

Building Pressure Control

- Maintains constant building pressure level
- Includes a static pressure transducer and outdoor static pressure assembly

Using differential pressure information between the outdoor air and the building air, the Lennox® CORE unit controller changes the Economizer position to help maintain a constant building pressure

NOTE - Not available with Demand Control Ventilation (CO₂ Sensor) or Outdoor Air CFM Control.

EXHAUST

Factory or Field Installed

14 Downflow Barometric Relief Dampers

- Allow relief of excess air
- Aluminum blade dampers prevent blow back and outdoor air infiltration during off cycle
- Exhaust hood is factory installed when dampers are factory installed with economizer
- Exhaust hood is furnished with dampers when ordered for field installation
- Bird screen furnished

Horizontal Barometric Relief Dampers

- For use when unit is configured for horizontal applications requiring an economizer
- Allows relief of excess air
- Aluminum blade dampers prevent blow back and outdoor air infiltration during off cycle
- Field installed in return air duct
- Bird screen and hood furnished

NOTE - Horizontal Economizer Conversion kit is available for field installation.

OPTIONS / ACCESSORIES

EXHAUST (continued)

Factory or Field Installed

- 15** Standard Static Power Exhaust
- Fans install internal to unit for downflow applications only with economizer option
 - Provides exhaust air pressure relief
 - Interlocked to run when return air dampers are closed and supply air blower is operating
 - Fans run based on air damper position (adjustable)
 - Three 1/3 HP motors
 - 20 in. diameter propeller-type fans
 - Five blades
 - Total power input of 1125 Watts
 - Total air volume of 12,800 cfm at 0 in. w.g.
 - Motor is inherently protected
 - Totally enclosed
 - Steel cabinet and hood painted to match unit

NOTE - Requires optional Downflow Economizer Barometric Relief Dampers. Also see Standard Static Power Exhaust Blower Tables.

Field Installed

High Static Power Exhaust

- Centrifugal-type power exhaust blowers
- Overload and sub-fuse protected
- Ball bearings
- Forward curved blades
- Blower wheel is statically and dynamically balanced
- Adjustable pulleys for speed adjustments

NOTE - High Static Power Exhaust (with VFD) features a solid-state analog pressure transducer control which senses differential pressure between conditioned space and outdoor air to regulate exhaust blower speed. Also see High Static Power Exhaust Blower Tables.

NOTE - High Static Power Exhaust is field installed but must be ordered at the same time as the rooftop unit so the unit can be factory configured for this option.

Control Choices

Damper Position Control

- For Standard Static Power Exhaust without VFD
- Lennox® CORE unit controller controls the power exhaust based on economizer damper position

Field Installed

Differential Pressure Transducer Control

- For Standard Static Power Exhaust or High Static Power Exhaust with VFD
- Lennox® CORE unit controller controls the power exhaust system based on a 0-10VDC signal from a differential pressure transducer, which compares atmospheric pressure to conditioned space static pressure

OUTDOOR AIR

Factory or Field Installed

Motorized Outdoor Air Dampers

- Linked mechanical dampers
- Fully modulating spring return damper motor with plug-in connection
- 0 to 25% (fixed) outdoor air adjustable
- Installs in unit
- Outdoor air hood with bird screen included

NOTE - Outdoor Air Hood is shipped separately in the unit with factory installed dampers for field installation.

Field Installed

Manual Outdoor Air Damper

- Adjustable slide damper
- Installed in unit
- Outdoor air hood with bird screen included

OPTIONS / ACCESSORIES

ROOF CURBS

- Nailer strip furnished (downflow only)
- Mates to unit
- US National Roofing Contractors Approved
- Shipped knocked down

Downflow

Hybrid Roof Curbs

- Interlocking tabs fasten corners together
- No tools required for assembly
- Can also be fastened together with furnished hardware
- Available in 14, 18, and 24 inch heights

Horizontal

- Converts unit from downflow to horizontal (side) air flow
- Return air is on unit
- Supply air is on curb
- Available in 37 inch and 41 inch heights.
- See dimension drawings

NOTE - Requires Horizontal Return Air Panel Kit.

NOTE - Optional Insulation Kit is available to help prevent sweating.

CEILING DIFFUSERS

Field Installed

Ceiling Diffusers

(Flush or Step-Down)

- White powder coat finish on diffuser face and grilles
- Insulated UL listed duct liner
- Diffuser box has collars for duct connection
- Step-down diffusers have double deflection blades
- Flush diffusers have fixed blades
- Provisions for suspending
- Internally sealed to prevent recirculation
- Removable return air grille
- Adapts to T-bar ceiling grids or plaster ceilings

Transitions (Supply and Return)

- Used with diffusers
- Installs in roof curb
- Galvanized steel construction
- Flanges furnished for duct connection to diffusers
- Fully insulated

OPTIONAL CONVENTIONAL TEMPERATURE CONTROL SYSTEMS

CS8500 Commercial 7-Day Programmable Thermostat

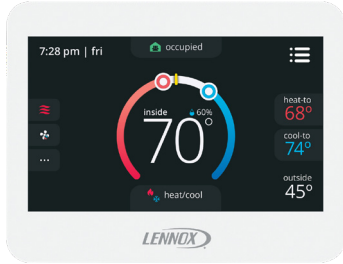

- Fully Communicating Sensor
- Full Color Touchscreen Interface
- Variable Speed System Control (On Compatible Units)
- Up To 4 Heat / 4 Cool
- Built-In Sensors For Temperature, Humidity And Optional CO₂
- Remote Sensor Options For Occupancy, Temperature
- BACnet Capable Options
- 5-2 or 7-Day Scheduling
- Smooth Setback Recovery
- Heat/Cool Auto-Changeover
- Four-Wire Installation
- FDD, ASHRAE, IECC Compliant

CS7500 Commercial 7-Day Programmable Thermostat



- Premium Universal Thermostat
- Full Color Touchscreen Interface
- Up To 4 Heat / 3 Cool
- Built-In Sensors For Temperature and Humidity
- Remote Sensors Options For Temperature, Discharge Air, Outdoor Air
- 5-2 or 7-Day Scheduling
- Smooth Setback Recovery
- Heat/Cool Auto-Changeover
- FDD, ASHRAE, IECC Compliant

CS3000 Commercial 5-2 Day Programmable Thermostat

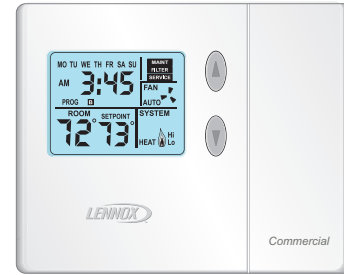

- Conventional Multi-Stage Thermostat
- Intuitive Display
- Push-Button Operation
- Up To 2 Heat / 2 Cool
- Built-In Temperature Sensor
- Remote Temperature Sensing
- Up to 5-2 Day Scheduling
- Smooth Setback Recovery
- Heat/Cool Auto-changeover

Wired Temperature/Humidity Room Sensor (Non-Communicating)



- Terminal blocks for wiring connections
- Five-wire sensor connection
- Off-white plastic enclosure
- Non-adjustable
- Relative humidity range: 0 -100%
- +/- 3% Accuracy

OPTIONAL CONVENTIONAL TEMPERATURE CONTROL SYSTEMS

Description	Order Number
CS8500 Commercial 7 Day Programmable Thermostat	
CS8500 7-Day Thermostat	No CO ₂ Sensing 24K55
	With CO ₂ Sensing 24K53
Sensors/Accessories	¹ Remote non-adjustable wall-mount 10k 47W37
	¹ Remote non-adjustable wall-mount 11k 94L61
Sysbus Network Cable (Yellow) for CS8500 and LCS-5030 Wired Room Sensor	
Twisted pair 100% shielded communication cable, Red and Black	500 ft. box 27M19
22 AWG, yellow jacket, rated at 75°C, 300V, Plenum rated	1000 ft. box 94L63
Insulation - Low smoke PVC, NEC, CMP	2500 ft. roll 68M25
CS7500 Commercial 7-Day Programmable Thermostat	
CS7500 7-Day Thermostat	24K41
Sensors/Accessories	² Remote non-adjustable wall-mount 20k 47W36
	² Remote non-adjustable wall-mount 10k 47W37
	Remote non-adjustable discharge air (duct mount) 19L22
	Outdoor temperature sensor X2658
CS3000 Commercial 5-2 Day Programmable Thermostat	
CS3000 5-2 Day Thermostat	11Y05
Sensors/Accessories	Remote non-adjustable wall mount 10k averaging 47W37
	Thermostat wall mounting plate X2659
Universal Thermostat Guard with Lock (clear)	
	Inside Dimensions (H x W x D) 5-7/8 x 8-3/8 x 3 in. 39P21
Temperature/Humidity Room Sensor	
A335MT13AE1 Wired Temperature/Humidity Room Sensor (Non-Communicating)	21W06

¹ Up to nine of the same type remote temperature sensors can be connected in parallel.

² Remote wall-mount sensors can be applied in any of the following combinations:

One Sensor - (1) 47W36, Two Sensors - (2) 47W37, Three Sensors - (2) 47W36 and (1) 47W37

Four Sensors - (4) 47W36, Five Sensors - (3) 47W36 and (2) 47W37

Objective: Outline the unit functions as a result of room thermostat or zone sensor demands.

Given: When economizer is present, it will function as an integral part of the unit cooling system. When not present, unit will function as if economizer is present but outdoor ambient is high and sensed as not suitable.

UNIT OPERATION WITH 2-STAGE THERMOSTAT (2 COOL AND 2 HEAT STAGES, Y1, Y2, W1, W2)

SUPPLY AIR BLOWER SPEED

Unit has following supply air blower speed setting:

- Ventilation speed
- Cooling Speed - Low
- Cooling Speed - High
- Heating speed
- Smoke speed (Used only in smoke removal option - not discussed)

COOLING

¹ Unit Features An Economizer And Outdoor Air Is Suitable

Thermostat Mode (Y1, Y2)

Y1 Demand:

All compressors are off, supply air blower is on low cooling speed to minimize blower power consumption, economizer modulates (minimum to maximum open position) to maintain 55°F supply air temperature (default unit controller setting).

Y2 Demand:

All compressors are off, supply air blower is on high cooling speed providing higher cooling capacity, and economizer modulates to maintain 55°F supply air temperature. If economizer stays at maximum open for 3 minutes, compressor 1 is energized while supply air blower stays on high cooling speed providing maximum cooling capacity.

¹ *Outdoor air suitability is determined by the energy state of outdoor ambient (enthalpy or sensible) and its ability to achieve the desired free cooling effects. Outdoor air suitability can also be determined by a third party controller and provided to the rooftop unit via a network connection.*

Unit Does Not Feature An Economizer Or Outdoor Air Is Not Suitable

Thermostat Mode (Y1, Y2)

Y1 Demand:

Compressor 1 operates, and supply air blower operates at low cooling speed.

Y2 Demand:

All compressors operate and supply air blower operates at high cooling speed.

UNIT OPERATION WITH 3-STAGE THERMOSTAT OR ZONE SENSOR (3 COOL AND 2 HEAT STAGES, Y1, Y2, Y3 AND W1, W2)**SUPPLY AIR BLOWER SPEED**

Unit has following supply air blower speed setting:

- Ventilation speed
- Cooling Speed - Low
- Cooling Speed - Medium
- Cooling Speed - High
- Heating speed
- Smoke speed (Used only in smoke removal option - not discussed)

COOLING**¹ Unit Features An Economizer And Outdoor Air Is Suitable****Thermostat or Zone Sensor Mode (Y1, Y2, Y3)****Y1 Demand:**

All compressors are off, supply air blower is on low cooling speed to minimize blower power consumption, economizer modulates (minimum to maximum open position) to maintain 55°F supply air temperature (default unit controller setting).

Y2 Demand:

All compressors are off, supply air blower is on high cooling speed providing higher cooling capacity, and economizer modulates to maintain 55°F supply air temperature. If economizer stays at maximum open for 3 minutes, compressor 1 is energized while supply air blower stays on high cooling speed providing maximum cooling capacity. After compressors are energized the economizer stays at maximum open.

Y3 Demand:

Compressors 1 and 2 are energized while supply air blower stays on high cooling speed.

¹ Outdoor air suitability is determined by the energy state of outdoor ambient (enthalpy or sensible) and its ability to achieve the desired free cooling effects. Outdoor air suitability can also be determined by a third party controller and provided to the rooftop unit via a network connection.

Unit Does Not Feature An Economizer or Outdoor Air Is Not Suitable**Thermostat or Zone Sensor Mode (Y1, Y2, Y3)****Y1 Demand:**

Compressor 1 operates at part load and supply air blower operates at low cooling speed.

Y2 Demand:

Compressor 1 operates at part load with compressor 2 ON, and supply air blower operates at medium cooling speed.

Y3 Demand:

All compressors operate and supply air blower operates at high cooling speed.

UNIT OPERATION WITH ZONE SENSOR (4 COOL AND 2 HEAT STAGES, Y1, Y2, Y3, Y4 AND W1, W2)**SUPPLY AIR BLOWER SPEED**

Unit has following supply air blower speed setting:

- Ventilation speed
- Cooling speed - Low
- Cooling speed - Medium-Low
- Cooling speed - Medium-High
- Cooling speed - High
- Heating speed
- Smoke speed (Used only in smoke removal option - not discussed)

COOLING**¹ Unit Features An Economizer And Outdoor Air Is Suitable****Y1 Demand:**

All compressors are off, supply air blower is on low cooling speed to minimize blower power consumption, economizer modulates (minimum to maximum open position) to maintain 55°F supply air temperature (default unit controller setting).

Y2 Demand:

All compressors are off, supply air blower is on high cooling speed providing higher cooling capacity, and economizer modulates to maintain 55°F supply air temperature.

If economizer stays at maximum open for 3 minutes, compressor 1 is energized while supply air blower stays on high cooling speed. After compressor 1 is energized the economizer stays at maximum open.

Y3 Demand:

Compressor 1 and 2 are energized while supply air blower is on high cooling speed providing even higher cooling capacity.

Y4 Demand:

All compressors are energized while supply air blower is on high cooling speed providing maximum cooling capacity.

¹ Outdoor air suitability is determined by the energy state of outdoor ambient (enthalpy or sensible) and its ability to achieve the desired free cooling effects. Outdoor air suitability can also be determined by a third party controller and provided to the RTU via a network connection.

Unit Does Not Feature An Economizer Or Outdoor Air Is Not Suitable**Y1 Demand:**

Compressor 1 operates at part load and supply air blower operates at low cooling speed.

Y2 Demand:

Compressors 2 operates and supply air blower operates at medium-low cooling speed.

Y3 Demand:

Compressor 1 operates at part load with compressor 2 ON and supply air blower operates at medium-high cooling speed.

Y4 Demand:

All compressors operate and supply air blower operates at high cooling speed.

DEFROST

Coil Sensors (RT48 - Circuit 1 and RT49 - Circuit 2) and Ambient Sensor (RT17) provides input to the Lennox® CORE Unit Controller to initiate a defrost cycle if needed.

Coil sensors are located on a return bend for each circuit on the front of the outdoor coil.

Ambient sensor is located on the inside of the corner mullion on the back of the outdoor coil section.

If a coil sensor measures a temperature below 35°F during mechanical heating mode, defrost logic is enabled. The system will constantly monitor coil and ambient temperatures and will initiate a defrost cycle if the controller determines that the target temperature difference between the coil and ambient temperature has been satisfied, or when the accumulated run time with coil temperature below 35°F reaches 6 hours.

Defrost will not be activated on more than one circuit at the time.

If the ambient sensor fails, or the circuit is in uncalibrated state, the controller will switch to time/temperature defrost operation.

Electric heat is energized during a defrost cycle to maintain discharge air temperature.

HEATING**Thermostat or Zone Sensor****W1/H1 Demand:**

A first-stage heating demand (W1/H1) will energize compressors 1 and 2 and the outdoor fans.

NOTE – L1 & L2 reversing valves are de-energized in the heating mode.

Units With Optional Electric Heat:

An increased heating demand (W2/H2) will energize electric heat.

NOTE – Compressors 1 and 2 stay energized.

Units With Optional Two-Stage Electric Heat and Zone Sensor mode:

An increased heating demand (H2) will energize 1st stage of electric heat.

An increased heating demand (H3) will energize 2nd stage of electric heat.

NOTE – Compressors 1 and 2 stay energized.

All Electric heat modules are energized during the defrost cycle (W1).

ACCESSORIES**Modulating Outdoor Air Damper**

The minimum damper position for “occupied low blower” and “occupied high blower” is adjusted during unit setup to provide minimum fresh air requirements per ASHRAE 62.1 at the corresponding supply air blower speeds.

- When supply air blower is off or the unit is in unoccupied mode, the outdoor air damper is closed.
- When unit is in occupied mode and supply air blower is operating at a speed below the “midpoint” blower speed, the outdoor air damper is at minimum “low blower” position.
- When unit is in occupied mode and supply air blower is operating at a speed equal to or above the “midpoint” blower speed, the outdoor air damper is at minimum “high blower” position.

NOTE - The “midpoint” blower speed is an average of the minimum and maximum blower speed (minimum speed + maximum speed divided by 2).

Power Exhaust Operation

NOTE - POWER EXHAUST OPERATION IS THE SAME FOR ALL CONTROL OPTIONS

MSAV® models are equipped with 2-stage power exhaust fans. Power exhaust fans operate when economizer outdoor air dampers are 50% open (adjustable). Power exhaust operates in 1st stage (one fan) up to 70% of supply air blower speed. 2nd stage power exhaust fans (both fans) operate when supply air blower speed is above 70% (adjustable) of full speed.

OPTIONS / ACCESSORIES

Item Description	Order Number	Size	
		302	
COOLING SYSTEM			
Condensate Drain Trap	PVC	22H54	X
	Copper	76W27	X
Drain Pan Overflow Switch		21Z07	OX
Stainless Steel Condensate Drain Pan		83W42	OX
BLOWER - SUPPLY AIR			
Motors	Belt Drive (standard efficiency) - 5 hp	Factory	O
	Belt Drive (standard efficiency) - 7.5 hp	Factory	O
	Belt Drive (standard efficiency) - 10 hp	Factory	O
	Automatic VFD Bypass Option (MSAV® Models Only)	Factory	O
Drive Kits See Blower Data Tables for usage and selection	Kit #1 740-895 rpm	Factory	O
	Kit #2 870-1045 rpm	Factory	O
	Kit #3 715-880 rpm	Factory	O
	Kit #4 770-965 rpm	Factory	O
	Kit #5 660-810 rpm	Factory	O
	Kit #6 770-965 rpm	Factory	O
	Kit #7 570-720 rpm	Factory	O
	Kit #8 480-630 rpm	Factory	O
	Kit #9 410-535 rpm	Factory	O
	Blower Belt Auto-Tensioner	38C61	X
CABINET			
Burglar Bars		Y1036	X
Combination Coil/Hail Guards		13T16	OX
Corrosion Protection		Factory	O
Horizontal Return Air Panel Kit		38K48	X
CONTROLS			
Commercial Controls	LonTalk® Module	54W27	OX
	Novar® LSE	Factory	O
Dirty Filter Switch		53W68	OX
Fresh Air Tempering		21Z08	OX
Smoke Detector - Supply or Return (Power board and one sensor)		37G73	OX
Smoke Detector - Supply and Return (Power board and two sensors)		37G74	OX

NOTE - Order numbers shown are for ordering field installed accessories.

OX - Configure To Order (Factory Installed) or Field Installed

O = Configure To Order (Factory Installed)

X = Field Installed

OPTIONS / ACCESSORIES

Item Description	Order Number	Size	
		302	
INDOOR AIR QUALITY			
Air Filters			
Healthy Climate® High Efficiency Air Filters 20 x 20 x 2 - order 12 per unit	MERV 8	54W21	OX
	MERV 13	52W39	OX
	MERV 16	21U40	X
Replaceable Media Filter with Metal Mesh Frame (includes Non-Pleated Filter Media) 20 x 20 x 2- order 12 per unit		44N60	X
Indoor Air Quality (CO₂) Sensors			
Sensor - Wall-mount, off-white plastic cover with LCD display		77N39	X
Sensor - Wall-mount, off-white plastic cover, no display		87N53	X
Sensor - Black plastic case, LCD display, rated for plenum mounting		87N52	X
Sensor - Black plastic case, no display, rated for plenum mounting		87N54	X
CO ₂ Sensor Duct Mounting Kit - for downflow applications		23Y47	X
Aspiration Box - for duct mounting non-plenum rated CO ₂ sensors (77N39)		90N43	X
ELECTRICAL			
Voltage 60 Hz	208/230V - 3 phase	Factory	O
	460V - 3 phase	Factory	O
	575V - 3 phase	Factory	O
¹ Short-Circuit Current Rating (SCCR) of 100kA (includes Phase/Voltage Detection)		Factory	O
HACR Circuit Breakers		Factory	O
² Disconnect Switch - See Electrical Accessories Tables on page 32 for selection	80 amp	54W85	OX
	150 amp	54W86	OX
	250 amp	54W87	OX
GFI Service Outlets	15 amp non-powered, field-wired (208/230V, 460V only)	74M70	OX
	^{3, 4} 15 amp factory-wired and powered (208/230V, 460V)	Factory	O
	⁵ 20 amp non-powered, field-wired (208/230V, 460V, 575V)	67E01	X
	⁵ 20 amp non-powered, field-wired (575V)	Factory	O
	Weatherproof Cover for GFI Phase/Voltage Detection		10C89 Factory
ELECTRIC HEAT			
30 kW	208/230V-3ph	30U68	OX
	460V-3ph	30U69	OX
	575V-3ph	30U70	OX
45 kW	208/230V-3ph	30U74	OX
	460V-3ph	30U75	OX
	575V-3ph	30U76	OX
60 kW	208/230V-3ph	30U80	OX
	460V-3ph	30U81	OX
	575V-3ph	30U82	OX
90 kW	460V-3ph	30U84	OX
	575V-3ph	30U85	OX

¹ SCCR option is only available with factory installed electric heat or no electric heat.
SCCR option is not available if the MOCP of the configured unit is greater than 200A.

² Disconnect Switch is furnished and factory installed with SCCR option

³ If a factory installed disconnect switch is ordered with a factory installed GFI, the default disconnect size is 150 amps.

⁴ Unit powered GFI Service Outlets are not available with SCCR option.
Disconnect Switch or Circuit Breaker is required with unit powered GFI Service Outlets.

⁵ Canada requires a minimum 20 amp circuit. Select 20 amp, non-powered, field wired GFI.

NOTE - Order numbers shown are for ordering field installed accessories.

OX - Configure To Order (Factory Installed) or Field Installed

O = Configure To Order (Factory Installed)

X = Field Installed

OPTIONS / ACCESSORIES

Item Description	Order Number	Size
		302
ECONOMIZER		
High Performance Economizer (Approved for California Title 24 Building Standards / AMCA Class 1A Certified)		
High Performance Economizer (Downflow or Horizontal) Includes Economizer Dampers with Outdoor Air Hood Downflow Applications - Use furnished Outdoor Air Hood - Order Downflow Barometric Relief Dampers with Exhaust Hood separately Horizontal Applications - Use furnished Outdoor Air Hood - Order Horizontal Barometric Relief Dampers with Exhaust Hood separately	18X87	OX
Economizer Controls		
Differential Enthalpy (Not for Title 24)	Order 2 21Z09	OX
Sensible Control	Sensor is Furnished Factory	O
Single Enthalpy (Not for Title 24)	21Z09	OX
Global	Sensor Field Provided Factory	O
Building Pressure Control	13J77	X
Differential Sensible	Sensor is Furnished Factory	O
Outdoor Air CFM Control	13J76	OX
Barometric Relief Dampers With Exhaust Hood		
Downflow Barometric Relief Dampers	76W17	OX
Horizontal Barometric Relief Dampers	33K78	OX
OUTDOOR AIR		
Outdoor Air Dampers With Outdoor Air Hood		
Motorized	18X89	OX
Manual	18X88	X
POWER EXHAUST		
Standard Static, SCCR Rated	208/230V 74W21	OX
	460V 74W22	OX
	575V 74W23	OX
High Static with VFD 2 hp (731-932 rpm)	208/230V 83M89	X
	460V 83M90	X
	575V 83M91	X
Power Exhaust Control		
Pressure Transducer Control	13J77	X

NOTE - Order numbers shown are for ordering field installed accessories.

OX - Configure To Order (Factory Installed) or Field Installed

O = Configure To Order (Factory Installed)

X = Field Installed

OPTIONS / ACCESSORIES

Item Description	Order Number	Size	
		302	
ROOF CURBS			
Hybrid Roof Curbs, Downflow			
14 in. height	11F62	X	
18 in. height	11F63	X	
24 in. height	11F64	X	
Standard Roof Curbs, Horizontal - Requires Horizontal Return Air Panel Kit			
30 in. height - slab applications	11T90	X	
41 in. height - rooftop applications	11T97	X	
Horizontal Return Air Panel Kit			
Required for Horizontal Applications with Roof Curb	38K48	X	
Insulation Kit For Standard Horizontal Curbs			
For 30 in. Curb	73K33	X	
For 41 in. Curb	73K35	X	
CEILING DIFFUSERS			
Step-Down - Order one	LARTD30/36S	45K74	X
Flush - Order one	LAFD30/36S	45K75	X
Transitions (Supply and Return) - Order one	LASRT30/36	33K80	X

NOTE - Order numbers shown are for ordering field installed accessories.

OX - Configure To Order (Factory Installed) or Field Installed

O = Configure To Order (Factory Installed)

X = Field Installed

SPECIFICATIONS

Model		LHT302H5M	
Nominal Tonnage		25 Ton	
Efficiency Type		High	
Blower Type		MSAV® Multi-Stage Air Volume	
Cooling Performance	Gross Cooling Capacity - Btuh	285,000	
	¹ Net Cooling Capacity (Btuh)	274,000	
	¹ AHRI Rated Air Flow (cfm)	8500	
	Total Unit Power - kW	25.9	
	¹ IEER (Btuh/Watt)	14.8	
	¹ EER (Btuh/Watt)	10.5	
Heating Performance	¹ Total High Heat Capacity - Btuh	270,000	
	¹ C.O.P.	3.3	
	Total Unit Power - kW	23.6	
	¹ Total Low Heat Capacity - Btuh	154,000	
	¹ C.O.P.	2.1	
Total Unit Power - kW		21.3	
Sound Rating Number		95 dBA	
Refrigerant Charge		Refrigerant Type R-454B	
		Circuit 1 29 lbs. 0 oz.	
		Circuit 2 28 lbs. 0 oz.	
Electric Heat Available		See page 31	
Compressor Type (number)		Two-Stage Scroll (1), Single-Stage Scroll (1)	
Outdoor Coils	Net face area - ft. ² (total)	68.3	
	Number of rows	2	
	Fins - in.	14	
Outdoor Coil Fans	Motor HP (number and type)	1/2 (6 PSC)	
	Rpm	1075	
	Watts (total)	3000	
	Diameter (Number) - in.	(6) 24	
	Blades	3	
	Total Air volume - cfm	21,500	
Indoor Coils	Net face area - ft. ² (total)	31.40	
	Tube diameter - in.	3/8	
	Rows	4	
	Fins - in.	14	
	Condensate drain size (NPT) - in.	(1) 1 in.	
	Expansion device type	Balanced Port Thermostatic Expansion Valve	
³ Indoor Blower and Kit Selection	Nominal motor HP	5, 7.5, 10	
	Maximum usable motor output (US Only)	5.75, 8.63, 11.5	
	Motor - Drive kit number	5 HP Kit 5 660-810 rpm Kit 6 770-965 rpm Kit 7 570-720 rpm Kit 8 480-630 rpm Kit 9 410-535 rpm	
		7.5 HP Kit 3 715-880 rpm Kit 4 770-965 rpm	
		10 HP Kit 1 740-895 rpm Kit 2 870-1045 rpm	
	Wheel (Number) diameter x width - in.	(2) 18 x 15	
	Filters	Type of filter	Fiberglass, disposable
		Number and size - in.	(12) 20 x 20 x 2
	Line voltage data (Volts-Phase-Hz)		208/230-3-60 460-3-60 575-3-60

NOTE - Net capacity includes evaporator blower motor heat deduction. Gross capacity does not include evaporator blower motor heat deduction.

¹ Tested at conditions included in with AHRI Standard 340/360; 95°F outdoor air temperature and 80°F db/67°F wb entering evaporator air; minimum external duct static pressure.

Cooling Ratings - 95°F outdoor air temperature and 80°F db/67°F wb entering indoor coil air.

High Temperature Heating Ratings - 47°F db/43°F wb outdoor air temperature and 70°F entering indoor coil air.

Low Temperature Heating Ratings - 17°F db/15°F wb outdoor air temperature and 70°F entering indoor coil air.

² Using total air volume and system static pressure requirements determine from blower performance tables rpm and motor output required. Maximum usable output of motors furnished are shown. In Canada, nominal motor output is also maximum usable motor output. If motors of comparable output are used, be sure to keep within the service factor limitations outlined on the motor nameplate.

RATINGS

NOTE – For Temperatures and Capacities not shown in tables, see bulletin – Cooling Unit Rating Table Correction Factor Data in Miscellaneous Engineering Data section.

25 TON HIGH EFFICIENCY LHT302H5M (1 COMPRESSOR - PART LOAD) - MSAV® MULTI-STAGE AIR VOLUME

Entering Wet Bulb Temperature	Total Air Volume	Outdoor Air Temperature Entering Outdoor Coil																			
		65°F					75°F					85°F					95°F				
		Total Cool Cap.	Comp. Motor Input	Sensible To Total Ratio (S/T)			Total Cool Cap.	Comp. Motor Input	Sensible To Total Ratio (S/T)			Total Cool Cap.	Comp. Motor Input	Sensible To Total Ratio (S/T)			Total Cool Cap.	Comp. Motor Input	Sensible To Total Ratio (S/T)		
				Dry Bulb					Dry Bulb					Dry Bulb					Dry Bulb		
cfm	kBtuh	kW	75°F	80°F	85°F	kBtuh	kW	75°F	80°F	85°F	kBtuh	kW	75°F	80°F	85°F	kBtuh	kW	75°F	80°F	85°F	
63°F	4000	125.4	5.27	0.79	0.95	1	118.5	6.11	0.81	0.96	1	109.6	7.09	0.82	0.98	1	101.1	8.21	0.85	1	1
	5000	131.9	5.27	0.86	0.99	1	124	6.1	0.88	1	1	116.3	7.07	0.9	1	1	108.4	8.19	0.93	1	1
	6000	137	5.28	0.92	1	1	130.2	6.1	0.93	1	1	122.6	7.06	0.95	1	1	114.2	8.17	0.98	1	1
67°F	4000	133.2	5.27	0.59	0.76	0.92	126.1	6.1	0.59	0.77	0.94	117.3	7.07	0.6	0.8	0.95	108.4	8.19	0.61	0.82	0.98
	5000	138.7	5.28	0.63	0.83	0.97	131.1	6.1	0.64	0.85	0.99	122.6	7.06	0.65	0.88	1	113.1	8.17	0.66	0.91	1
	6000	143.1	5.29	0.67	0.89	1	135	6.11	0.68	0.92	1	126.3	7.06	0.7	0.94	1	116.7	8.17	0.72	0.96	1
71°F	4000	142.3	5.29	0.4	0.57	0.73	134.6	6.1	0.4	0.58	0.74	126.3	7.06	0.39	0.58	0.76	117	8.17	0.39	0.59	0.79
	5000	147.4	5.3	0.41	0.61	0.8	139.8	6.11	0.41	0.62	0.82	130.6	7.06	0.41	0.63	0.85	120.8	8.17	0.41	0.65	0.88
	6000	151.1	5.32	0.43	0.65	0.87	143	6.12	0.43	0.67	0.9	133.9	7.06	0.43	0.69	0.92	124.2	8.16	0.43	0.71	0.95

25 TON HIGH EFFICIENCY LHT302H5M (2 COMPRESSORS - PART LOAD / FULL LOAD) - MSAV® MULTI-STAGE AIR VOLUME

Entering Wet Bulb Temperature	Total Air Volume	Outdoor Air Temperature Entering Outdoor Coil																			
		85°F					95°F					105°F					115°F				
		Total Cool Cap.	Comp. Motor Input	Sensible To Total Ratio (S/T)			Total Cool Cap.	Comp. Motor Input	Sensible To Total Ratio (S/T)			Total Cool Cap.	Comp. Motor Input	Sensible To Total Ratio (S/T)			Total Cool Cap.	Comp. Motor Input	Sensible To Total Ratio (S/T)		
				Dry Bulb					Dry Bulb					Dry Bulb					Dry Bulb		
cfm	kBtuh	kW	75°F	80°F	85°F	kBtuh	kW	75°F	80°F	85°F	kBtuh	kW	75°F	80°F	85°F	kBtuh	kW	75°F	80°F	85°F	
63°F	6000	225.2	14.18	0.71	0.85	0.99	208.5	16.2	0.72	0.87	1	191.7	18.44	0.73	0.9	1	173.9	20.9	0.75	0.94	1
	8000	241.7	14.22	0.78	0.96	1	224.7	16.24	0.8	0.98	1	207.7	18.48	0.83	1	1	191.1	20.95	0.86	1	1
	10000	257.3	14.26	0.86	1	1	241.3	16.29	0.89	1	1	224.6	18.54	0.92	1	1	207	21.01	0.95	1	1
67°F	6000	243.5	14.23	0.55	0.68	0.82	225.4	16.24	0.55	0.69	0.84	207.4	18.49	0.55	0.71	0.86	188.7	20.96	0.55	0.73	0.89
	8000	258.8	14.27	0.59	0.76	0.92	240.8	16.3	0.6	0.78	0.95	221.8	18.55	0.61	0.8	0.98	201.6	21	0.62	0.83	1
	10000	270.6	14.31	0.64	0.84	1	251.1	16.34	0.65	0.86	1	231	18.57	0.67	0.9	1	209.8	21.03	0.69	0.93	1
71°F	6000	260	14.26	0.41	0.53	0.66	242.8	16.3	0.4	0.53	0.67	224.7	18.55	0.39	0.54	0.68	203.3	21.01	0.38	0.54	0.7
	8000	278.3	14.34	0.43	0.58	0.74	259.4	16.36	0.42	0.59	0.76	238.3	18.6	0.42	0.6	0.78	218.2	21.06	0.41	0.61	0.81
	10000	288	14.39	0.45	0.63	0.82	269.4	16.41	0.45	0.65	0.84	247.2	18.64	0.45	0.66	0.87	225.9	21.1	0.45	0.68	0.91

25 TON HIGH EFFICIENCY LHT302H5M (2 COMPRESSORS - FULL LOAD) - MSAV® MULTI-STAGE AIR VOLUME

Entering Wet Bulb Temperature	Total Air Volume	Outdoor Air Temperature Entering Outdoor Coil																			
		85°F					95°F					105°F					115°F				
		Total Cool Cap.	Comp. Motor Input	Sensible To Total Ratio (S/T)			Total Cool Cap.	Comp. Motor Input	Sensible To Total Ratio (S/T)			Total Cool Cap.	Comp. Motor Input	Sensible To Total Ratio (S/T)			Total Cool Cap.	Comp. Motor Input	Sensible To Total Ratio (S/T)		
				Dry Bulb					Dry Bulb					Dry Bulb					Dry Bulb		
cfm	kBtuh	kW	75°F	80°F	85°F	kBtuh	kW	75°F	80°F	85°F	kBtuh	kW	75°F	80°F	85°F	kBtuh	kW	75°F	80°F	85°F	
63°F	8000	278.2	17.98	0.74	0.89	1	259.6	20.16	0.75	0.91	1	241.4	22.56	0.76	0.93	1	222.2	25.17	0.78	0.96	1
	10000	292.3	18.14	0.8	0.96	1	273.3	20.33	0.81	0.98	1	255.9	22.77	0.84	1	1	237.7	25.4	0.87	1	1
	12000	305.3	18.28	0.86	1	1	287.8	20.52	0.88	1	1	270.4	22.94	0.91	1	1	251.7	25.61	0.94	1	1
67°F	8000	296.5	18.19	0.57	0.71	0.85	278.2	20.39	0.57	0.73	0.87	259.9	22.81	0.58	0.74	0.9	239.3	25.43	0.58	0.76	0.93
	10000	311.7	18.36	0.61	0.78	0.94	291	20.56	0.62	0.79	0.96	270.5	22.95	0.63	0.82	0.98	249.7	25.59	0.63	0.84	1
	12000	320.3	18.46	0.65	0.84	0.99	300.4	20.67	0.66	0.86	1	278.1	23.06	0.67	0.89	1	256.5	25.68	0.69	0.92	1
71°F	8000	316.7	18.41	0.42	0.56	0.69	297.8	20.63	0.42	0.56	0.7	278.2	23.05	0.41	0.57	0.72	256.3	25.67	0.4	0.57	0.74
	10000	331	18.59	0.44	0.6	0.75	310.2	20.8	0.44	0.61	0.77	289.7	23.21	0.43	0.62	0.79	267.7	25.83	0.43	0.63	0.82
	12000	341.5	18.71	0.46	0.64	0.82	320.5	20.94	0.46	0.65	0.84	298.2	23.33	0.46	0.66	0.87	274.8	25.91	0.45	0.68	0.9

25 TON - HEATING LHT320H5M

Indoor Coil Air Volume 70°F Dry Bulb cfm	Air Temperature Entering Outdoor Coil									
	65°F		45°F		25°F		5°F		-15°F	
	Total Heating Capacity	Comp. Motor Input	Total Heating Capacity	Comp. Motor Input	Total Heating Capacity	Comp. Motor Input	Total Heating Capacity	Comp. Motor Input	Total Heating Capacity	Comp. Motor Input
	kBtuh	kW	kBtuh	kW	kBtuh	kW	kBtuh	kW	kBtuh	kW
8000	362	19	265.4	17.11	185.9	15.2	121.2	13.7	79	11.93
10000	367.4	17.55	269.2	16.09	186.4	14.5	122.8	13.5	79.2	11.82
12000	370.6	16.63	270.1	15.46	187.2	14.16	122.9	13.42	79.3	11.8

BLOWER DATA

BLOWER TABLE INCLUDES RESISTANCE FOR BASE UNIT ONLY WITH DRY INDOOR COIL & AIR FILTERS IN PLACE FOR ALL UNITS ADD:

- 1 - Wet indoor coil air resistance of selected unit.
- 2 - Any factory installed options air resistance (electric heat, economizer, etc.)
- 3 - Any field installed accessories air resistance (electric heat, duct resistance, diffuser, etc.)

Then determine from blower table blower motor output and drive required.

See page 27 for wet coil and option/accessory air resistance data.

See page 27 for factory installed drive kit specifications.

MINIMUM AIR VOLUME REQUIRED FOR USE WITH OPTIONAL ELECTRIC HEAT

All units require 8000 cfm minimum air with electric heat.

Air Volume cfm	TOTAL STATIC PRESSURE - In. w.g.																									
	0.20		0.40		0.60		0.80		1.00		1.20		1.40		1.60		1.80		2.00		2.20		2.40		2.60	
	RPM	BHP	RPM	BHP	RPM	BHP	RPM	BHP	RPM	BHP	RPM	BHP	RPM	BHP	RPM	BHP	RPM	BHP	RPM	BHP	RPM	BHP	RPM	BHP	RPM	BHP
4000	372	0.26	433	0.65	497	0.99	565	1.27	630	1.54	687	1.79	738	2.04	784	2.30	824	2.56	861	2.82	897	3.10	932	3.40	974	4.01
4500	382	0.41	441	0.79	506	1.12	574	1.41	638	1.69	694	1.95	744	2.22	790	2.50	831	2.77	868	3.05	903	3.35	938	3.66	974	4.30
5000	392	0.56	451	0.93	516	1.25	584	1.55	646	1.85	702	2.12	751	2.41	796	2.70	837	3.00	874	3.30	909	3.61	944	3.93	980	4.60
5500	402	0.73	462	1.08	527	1.40	594	1.72	655	2.02	710	2.31	758	2.61	802	2.92	843	3.24	880	3.56	916	3.88	951	4.22	987	4.90
6000	414	0.89	473	1.24	539	1.56	605	1.90	665	2.21	718	2.51	766	2.83	809	3.16	850	3.51	887	3.84	922	4.18	957	4.52	994	5.24
6500	426	1.07	486	1.41	551	1.74	616	2.10	675	2.42	727	2.73	774	3.07	817	3.43	857	3.80	894	4.15	929	4.49	964	4.85	1001	5.59
7000	439	1.26	499	1.60	565	1.93	628	2.31	685	2.64	737	2.97	782	3.34	825	3.72	864	4.11	901	4.48	937	4.83	971	5.19	1008	5.97
7500	453	1.46	513	1.79	579	2.14	641	2.55	696	2.88	747	3.24	792	3.63	833	4.04	872	4.45	909	4.83	945	5.20	979	5.56	1016	6.37
8000	467	1.66	528	2.00	593	2.38	653	2.81	708	3.15	757	3.53	801	3.95	843	4.39	881	4.82	918	5.22	953	5.59	988	5.96	1025	6.81
8500	483	1.88	544	2.22	608	2.65	667	3.10	720	3.44	768	3.85	812	4.30	852	4.78	890	5.22	927	5.63	962	6.01	997	6.39	1034	7.28
9000	499	2.11	561	2.47	624	2.95	681	3.41	733	3.76	780	4.20	823	4.69	862	5.19	900	5.65	936	6.07	972	6.46	1007	6.85	1044	7.78
9500	516	2.36	578	2.75	640	3.26	696	3.73	746	4.10	792	4.58	834	5.11	873	5.64	910	6.12	946	6.54	982	6.93	1018	7.34	1055	8.32
10,000	534	2.64	596	3.06	657	3.60	711	4.07	760	4.48	805	5.00	845	5.57	884	6.12	921	6.61	957	7.03	992	7.43	1028	7.86	1066	8.89
10,500	553	2.93	615	3.39	674	3.95	727	4.44	775	4.90	817	5.46	857	6.06	895	6.62	932	7.12	967	7.55	1003	7.96	1039	8.40	1077	9.49
11,000	572	3.24	634	3.74	692	4.31	744	4.83	789	5.35	830	5.95	869	6.58	907	7.16	943	7.65	978	8.09	1013	8.51	1050	8.98	1089	10.12
11,500	592	3.58	653	4.12	711	4.70	760	5.27	803	5.85	843	6.49	881	7.13	918	7.71	954	8.21	989	8.65	1025	9.10	1062	9.59	1101	10.12
12,000	613	3.95	674	4.53	729	5.14	776	5.75	818	6.39	857	7.06	894	7.71	930	8.30	965	8.80	1000	9.25	1036	9.71	1073	10.22	1111	11.12
12,500	635	4.37	695	4.98	748	5.62	792	6.29	832	6.98	870	7.67	906	8.33	941	8.91	976	9.42	1011	9.87	1048	10.35	1085	10.73	1121	12.02

BLOWER DATA

DRIVE KIT SPECIFICATIONS

Motor Efficiency	Nominal hp	Maximum hp	Drive Kit Number	RPM Range
Standard	5	5.75	5	660 - 810
Standard	5	5.75	6	770 - 965
Standard	5	5.75	7	570 - 720
Standard	5	5.75	8	480 - 630
Standard	5	5.75	9	410 - 535
Standard	7.5	8.63	3	715 - 880
Standard	7.5	8.63	4	770 - 965
Standard	10	11.50	1	740 - 895
Standard	10	11.50	2	870 - 1045

NOTES

Using total air volume and system static pressure requirements determine from blower performance tables rpm and motor output required. Maximum usable output of motors furnished are shown. In Canada, nominal motor output is also maximum usable motor output. If motors of comparable output are used, be sure to keep within the service factor limitations outlined on the motor nameplate.

For VFD applications, nominal motor output is also maximum usable motor output.

FACTORY INSTALLED OPTIONS/FIELD INSTALLED ACCESSORY AIR RESISTANCE

Air Volume cfm	Wet Indoor Coil in. w.g.	Electric Heat in. w.g.	Economizer in. w.g.	Filters			Horizontal Roof Curb in. w.g.
				MERV 8	MERV 13	MERV 16	
				in. w.g.	in. w.g.	in. w.g.	
4000	0.04	0.01	0.00	0.00	0.00	0.06	0.04
4500	0.04	0.01	0.00	0.00	0.00	0.07	0.05
5000	0.05	0.01	0.00	0.00	0.00	0.08	0.06
5500	0.06	0.02	0.01	0.00	0.01	0.09	0.07
6000	0.07	0.02	0.01	0.00	0.02	0.10	0.08
6500	0.08	0.02	0.01	0.01	0.02	0.11	0.09
7000	0.09	0.03	0.02	0.01	0.03	0.12	0.10
7500	0.10	0.03	0.02	0.01	0.04	0.13	0.11
8000	0.11	0.03	0.02	0.01	0.04	0.14	0.13
8500	0.12	0.04	0.03	0.01	0.04	0.15	0.15
9000	0.13	0.04	0.04	0.01	0.04	0.16	0.17
9500	0.14	0.05	0.04	0.02	0.06	0.17	0.19
10,000	0.15	0.05	0.05	0.02	0.06	0.18	0.21
10,500	0.16	0.06	0.06	0.02	0.06	0.19	0.24
11,000	0.18	0.06	0.07	0.02	0.07	0.20	0.27
11,500	0.19	0.07	0.08	0.02	0.08	0.22	0.30
12,000	0.20	0.07	0.10	0.02	0.08	0.23	0.33
12,500	0.21	0.08	0.11	0.03	0.10	0.24	0.37

BLOWER DATA

POWER EXHAUST PERFORMANCE - STANDARD STATIC

Return Duct Negative Static Pressure	Air Volume Exhausted
in. w.g.	cfm
0.00	12,800
0.05	12,200
0.10	11,500
0.15	10,800
0.20	9900
0.25	9000
0.30	7900
0.35	6750
0.40	5450
0.45	4150
0.50	2900

POWER EXHAUST - HIGH STATIC

Air Volume cfm	Return Duct Negative Static Pressure - In. w.g.																					
	0		0.10		0.20		0.30		0.40		0.50		0.60		0.70		0.80		0.90		1.0	
	RPM	BHP	RPM	BHP	RPM	BHP	RPM	BHP	RPM	BHP	RPM	BHP	RPM	BHP	RPM	BHP	RPM	BHP	RPM	BHP	RPM	BHP
8500	487	0.43	501	0.44	521	0.46	548	0.49	584	0.53	625	0.58	667	0.64	708	0.70	746	0.75	783	0.81	818	0.87
9000	515	0.51	528	0.52	547	0.54	570	0.57	601	0.61	638	0.66	678	0.71	717	0.77	755	0.83	791	0.90	826	0.96
9500	544	0.60	556	0.61	573	0.63	594	0.66	620	0.69	652	0.74	689	0.80	727	0.86	765	0.93	800	0.99	834	1.05
10,000	572	0.70	584	0.71	599	0.73	618	0.76	641	0.79	669	0.83	702	0.89	738	0.95	774	1.02	810	1.09	843	1.15
10,500	601	0.81	612	0.82	626	0.84	643	0.87	663	0.90	688	0.94	718	0.99	750	1.05	785	1.12	819	1.19	853	1.27
11,000	629	0.93	640	0.95	653	0.97	668	0.99	687	1.02	709	1.06	735	1.11	764	1.16	796	1.23	830	1.31	862	1.38
11,500	658	1.06	668	1.08	680	1.10	694	1.12	711	1.15	731	1.19	754	1.24	780	1.29	810	1.36	841	1.43	872	1.50
12,000	686	1.21	696	1.22	707	1.24	721	1.27	736	1.30	754	1.34	774	1.38	798	1.43	825	1.49	853	1.56	883	1.64

BLOWER DATA

CEILING DIFFUSER AIR RESISTANCE - in. w.g.

Air Volume cfm	Step-Down Diffuser			Flush Diffuser
	LARTD30/36S			LAFD30/36S
	2 Ends Open	1 Side/2 Ends Open	All Ends & Sides Open	
7500	0.37	0.31	0.25	0.29
8000	0.42	0.36	0.29	0.34
8500	0.48	0.41	0.34	0.39
9000	0.55	0.47	0.39	0.44
9500	0.62	0.53	0.45	0.51
10,000	0.70	0.60	0.51	0.57
10,500	0.78	0.68	0.58	0.65
11,000	0.87	0.76	0.65	0.72
11,500	0.97	0.85	0.73	0.81
12,000	1.08	0.94	0.82	0.9

CEILING DIFFUSER AIR THROW DATA - ft.

Air Volume cfm	¹ Effective Throw Range - ft.	
	Step-Down	Flush
9000	40 - 47	29 - 35
9500	43 - 50	33 - 41
10,000	46 - 54	37 - 46
10,500	50 - 58	42 - 51
11,000	53 - 61	46 - 56
11,500	55 - 64	50 - 61
12,000	58 - 67	54 - 66

¹ Throw is the horizontal or vertical distance an airstream travels on leaving the outlet or diffuser before the maximum velocity is reduced to 50 ft. per minute. Four sides open.

ELECTRICAL DATA

Model		LHT302H5M								
		208/230V - 3 Ph			460V - 3 Ph			575V - 3 Ph		
¹ Voltage - 60Hz										
Compressor 1	Rated Load Amps	46.5			21.2			16.9		
	Locked Rotor Amps	335.5			141			109		
Compressor 2	Rated Load Amps	31.8			15			11.9		
	Locked Rotor Amps	255			123			93.7		
Outdoor Fan Motors (6)	Full Load Amps (6 Non-ECM)	3			1.5			1.2		
	Total	18			9			7.2		
Standard Power Exhaust (3) 0.33 HP	Full Load Amps	2.4			1.3			1		
	Total	7.2			3.9			3		
High Static Power Exhaust (3) 2 HP	Full Load Amps	7.5			3.4			2.7		
	Total	22.5			10.2			8.1		
Service Outlet 115V GFI (amps)		15			15			20		
Indoor Blower Motor	HP	5	7.5	10	5	7.5	10	5	7.5	10
	Full Load Amps	16.7	24.2	30.8	7.6	11	14	6.1	9	11
² Maximum Overcurrent Protection (MOCP)	Unit Only	150	175	175	70	80	80	60	60	60
	With (3) 0.33 HP Standard Power Exhaust	175	175	175	80	80	80	60	60	70
	With High Static Power Exhaust (3) 2 HP	175	200	200	80	90	90	70	70	70
³ Minimum Circuit Ampacity (MCA)	Unit Only	125	133	139	59	62	65	47	50	52
	With (3) 0.33 HP Standard Power Exhaust	132	140	146	62	66	69	50	53	55
	With High Static Power Exhaust (3) 2 HP	148	155	162	69	72	75	55	58	60

NOTE - All units have a minimum Short Circuit Current Rating (SCCR) of 5000 amps.

¹ Extremes of operating range are plus and minus 10% of line voltage.

² HACR type breaker or fuse.

³ Refer to National or Canadian Electrical Code manual to determine wire, fuse and disconnect size requirements.

ELECTRIC HEAT DATA

Model			LHT302H5M											
¹ Voltage - 60Hz			208/230V - 3 Ph						460V - 3 Ph			575V - 3 Ph		
Indoor Blower Motor - HP			5		7.5		10		5	7.5	10	5	7.5	10
Electric Heat Voltage			208V	240V	208V	240V	208V	240V	480V	480V	480V	600V	600V	600V
² Maximum Overcurrent Protection (MOCP)	Unit+ Electric Heat	30 kW	225	225	⁴ 225	250	⁴ 225	250	110	110	110	90	90	90
		45 kW	⁴ 250	⁴ 300	⁴ 250	⁴ 300	300	⁴ 300	150	150	150	110	110	110
		60 kW	⁴ 250	⁴ 300	300	⁴ 300	300	⁴ 300	150	150	150	110	110	125
		90 kW	N/A	N/A	N/A	N/A	N/A	N/A	175	175	175	150	150	150
³ Minimum Circuit Ampacity (MCA)	Unit+ Electric Heat	30 kW	203	215	211	223	217	229	104	107	110	83	86	88
		45 kW	242	260	250	268	256	275	126	130	133	101	104	106
		60 kW	250	269	258	277	264	284	131	134	137	105	107	109
		90 kW	N/A	N/A	N/A	N/A	N/A	N/A	167	170	173	133	136	138
² Maximum Overcurrent Protection (MOCP)	Unit+ Electric Heat and Standard Power Exhaust (3) 0.33 HP	30 kW	⁴ 225	250	⁴ 225	250	250	250	110	125	125	90	90	100
		45 kW	⁴ 250	⁴ 300	300	⁴ 300	300	⁴ 300	150	150	150	110	110	110
		60 kW	300	⁴ 300	300	⁴ 300	300	⁴ 300	150	150	150	110	125	125
		90 kW	N/A	N/A	N/A	N/A	N/A	N/A	175	175	200	150	150	150
³ Minimum Circuit Ampacity (MCA)	Unit+ Electric Heat and Standard Power Exhaust (3) 0.33 HP	30 kW	211	223	218	230	225	237	108	111	114	86	89	91
		45 kW	250	268	257	275	264	282	130	134	137	104	107	109
		60 kW	257	277	265	284	272	291	135	138	141	108	110	112
		90 kW	N/A	N/A	N/A	N/A	N/A	N/A	171	174	177	136	139	141
² Maximum Overcurrent Protection (MOCP)	Unit+ Electric Heat and High Static Power Exhaust (3) 2 HP	30 kW	250	250	250	250	⁴ 250	⁴ 300	125	125	125	100	100	100
		45 kW	300	⁴ 300	300	⁴ 300	300	⁴ 300	150	150	150	110	125	125
		60 kW	300	⁴ 300	300	⁴ 300	⁴ 300	⁴ 350	150	150	150	125	125	125
		90 kW	N/A	N/A	N/A	N/A	N/A	N/A	200	200	200	150	150	150
³ Minimum Circuit Ampacity (MCA)	Unit+ Electric Heat and High Static Power Exhaust (3) 2 HP	30 kW	226	238	233	245	240	252	114	117	120	91	94	96
		45 kW	265	283	272	290	279	297	136	140	143	109	112	114
		60 kW	273	292	280	299	287	306	141	144	147	113	116	118
		90 kW	N/A	N/A	N/A	N/A	N/A	N/A	177	180	183	142	144	146

¹ Extremes of operating range are plus and minus 10% of line voltage.

² HACR type breaker or fuse.

³ Refer to National or Canadian Electrical Code manual to determine wire, fuse and disconnect size requirements.

⁴ Factory installed circuit breaker not available.

ELECTRIC HEAT CAPACITIES

Volts Input	30 kW			45 kW			60 kW			90 kW		
	kW Input	Btuh Output	Stages	kW Input	Btuh Output	Stages	kW Input	Btuh Output	Stages	kW Input	Btuh Output	Stages
208	22.5	76,800	1	33.8	115,300	2	45.0	153,600	2	N/A	N/A	N/A
220	25.2	86,000	1	37.8	129,000	2	50.4	172,000	2	N/A	N/A	N/A
230	27.5	93,900	1	41.3	141,000	2	55.1	188,000	2	N/A	N/A	N/A
240	30.0	102,400	1	45.0	153,600	2	60.0	204,800	2	N/A	N/A	N/A
440	25.2	86,000	1	37.8	129,000	2	50.4	172,000	2	75.6	258,000	2
460	27.5	93,900	1	41.3	141,000	2	55.1	188,000	2	82.7	282,200	2
480	30.0	102,400	1	45.0	153,600	2	60.0	204,800	2	90.0	307,100	2
550	25.2	86,000	1	37.8	129,000	2	50.4	172,000	2	75.6	258,000	2
575	27.5	93,900	1	41.3	141,000	2	55.1	188,000	2	82.7	282,200	2
600	30.0	102,400	1	45.0	153,600	2	60.0	204,800	2	90.0	307,100	2

ELECTRICAL ACCESSORIES - DISCONNECTS

Model			LHT302H5M								
Voltage - 60Hz - 3 phase			208/230V			460V			575V		
Indoor Blower Motor		HP	5	7.5	10	5	7.5	10	5	7.5	10
Disconnect	Unit Only		54W86	54W86	54W86	54W85	54W85	54W85	54W85	54W85	54W85
	Unit+ Electric Heat and Standard Power Exhaust (3) 0.33 HP	0 kW	54W86	54W86	54W87	54W85	54W85	54W85	54W85	54W85	54W85
		30 kW	54W87	54W87	54W87	54W86	54W86	54W86	54W86	54W86	54W86
		45 kW	N/A	N/A	N/A	54W86	54W86	54W86	54W86	54W86	54W86
		60 kW	N/A	N/A	N/A	54W86	54W87	54W87	54W86	54W86	54W86
		90 kW	N/A	N/A	N/A	54W87	54W87	54W87	54W87	54W87	54W87
	Unit+ Electric Heat and High Static Power Exhaust (3) 2 HP	0 kW	54W87	54W87	54W87	54W85	54W85	54W85	54W85	54W85	54W85
		30 kW	54W87	54W87	N/A	54W86	54W86	54W86	54W86	54W86	54W86
		45 kW	N/A	N/A	N/A	54W86	54W86	54W86	54W86	54W86	54W86
		60 kW	N/A	N/A	N/A	54W87	54W87	54W87	54W86	54W86	54W86
	90 kW	N/A	N/A	N/A	54W87	54W87	54W87	54W87	54W87	54W87	

Disconnects - 54W85 - 80A
 54W86 - 150A
 54W87 - 250A

NOTE - All units have a minimum Short Circuit Current Rating (SCCR) of 5000 amps.

UNIT CLEARANCES

Unit With Economizer

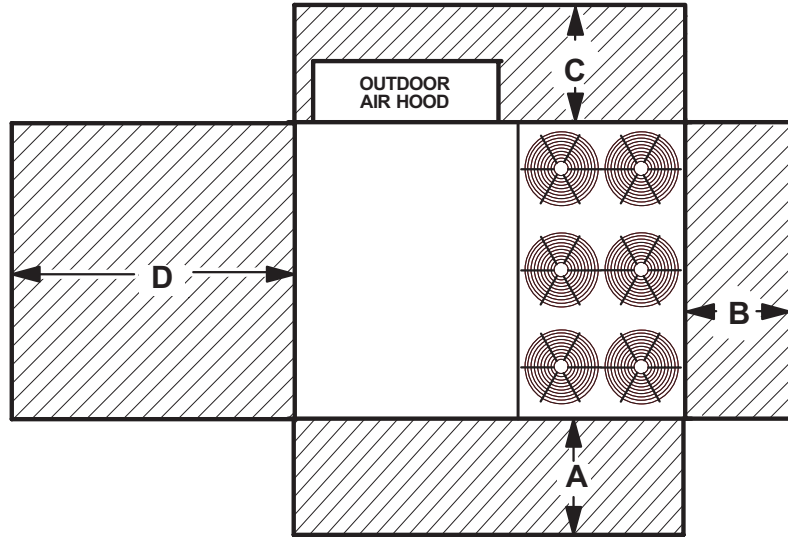

¹ Unit Clearance	A		B		C		D		Top Clearance
	in.	mm	in.	mm	in.	mm	in.	mm	
Service Clearance	60	1524	36	914	36	914	66	1676	Unobstructed
Minimum Operation Clearance	45	1143	36	914	36	914	41	1041	

NOTE - Entire perimeter of unit base requires support when elevated above the mounting surface.

¹ **Service Clearance** - Required for removal of serviceable parts.

Minimum Operation Clearance - Required clearance for proper unit operation.

Unit With High Static Power Exhaust Fans

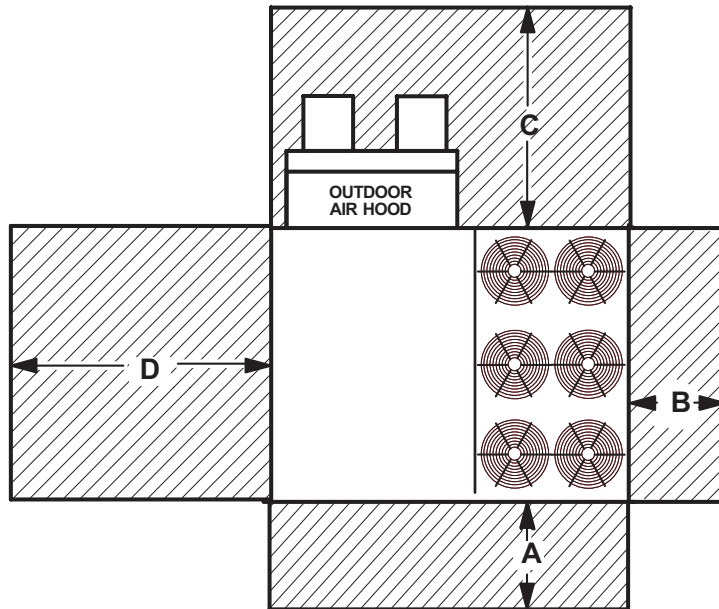

¹ Unit Clearance	A		B		C		D		Top Clearance
	in.	mm	in.	mm	in.	mm	in.	mm	
Service Clearance	60	1524	36	914	80	2032	66	1676	Unobstructed
Minimum Operation Clearance	45	1143	36	914	80	2032	41	1041	

NOTE - Entire perimeter of unit base requires support when elevated above the mounting surface.

¹ **Service Clearance** - Required for removal of serviceable parts.

Minimum Operation Clearance - Required clearance for proper unit operation.

UNIT CLEARANCES

Unit With Horizontal Barometric Relief Dampers

NOTE Allow adequate clearance for duct and barometric relief damper installation.

NOTE Dampers may be installed on each side of return air duct or end to end on one side of return air duct.

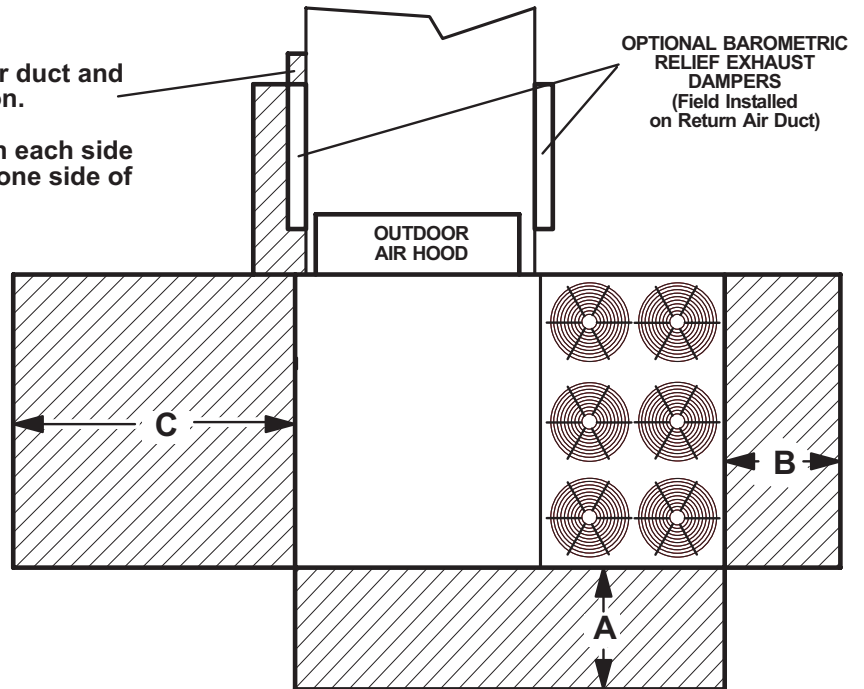

¹ Unit Clearance	A		B		C		Top Clearance
	in.	mm	in.	mm	in.	mm	
Service Clearance	60	1524	36	914	66	1676	Unobstructed
Minimum Operation Clearance	45	1143	36	914	41	1041	

NOTE - Entire perimeter of unit base requires support when elevated above the mounting surface.

¹ **Service Clearance** - Required for removal of serviceable parts.

Minimum Operation Clearance - Required clearance for proper unit operation.

OUTDOOR SOUND DATA

Size	Octave Band Sound Power Levels dBA, re 10 ⁻¹² Watts - Center Frequency - Hz							¹ Sound Rating Number (dBA)
	125	250	500	1000	2000	4000	8000	
302	84	85	90	90	85	80	72	95

Note - The octave band sound power data does not include tonal corrections.

¹ Tested according to AHRI Standard 370-2001 test conditions (includes pure tone penalty).

Sound Rating Number is the overall A-Weighted Sound Power Level, (LWA), dB (100 Hz to 10,000 Hz).

WEIGHT DATA

Size	Net		Shipping	
	lbs.	kg	lbs.	kg
302 Base Unit	2997	1359	3207	1455
302 Max. Unit	3509	1592	3719	1687

FACTORY / FIELD INSTALLED OPTIONS AND ACCESSORIES - NET WEIGHTS

Description	lbs.	kg
ECONOMIZER / OUTDOOR AIR / EXHAUST		
Economizer	138	63
Barometric Relief		
Downflow Barometric Relief Dampers	45	20
Horizontal Barometric Relief Dampers	20	9
Outdoor Air Dampers		
Damper Section (downflow) Motorized	72	33
Damper Section (downflow) Manual	68	31
Outdoor Air Hood (downflow)	76	34
Power Exhaust		
Standard Static	99	45
High Static with or without VFD	525	238
ELECTRIC HEAT		
30 KW	59	27
45 KW	76	34
60 KW	76	34
90 KW	84	38
COMBINATION COIL/HAIL GUARDS		
All models	63	29
ROOF CURBS		
Hybrid Roof Curbs, Downflow		
14 in. height	205	93
18 in. height	235	107
24 in. height	270	123
Standard Curbs, Horizontal		
30 in. height	495	225
41 in. height	575	261
Insulation Kit for Horizontal Curbs		
30 in. height	45	21
41 in. height	55	25
CEILING DIFFUSERS		
Step-Down LARTD30/36S	625	283
Flush LAFD30/36S	625	283
Transitions LASRT30/36	85	39

DIMENSIONS

UNIT

CORNER WEIGHTS									CENTER OF GRAVITY			
Model	AA		BB		CC		DD		EE		FF	
	lbs.	kg	lbs.	kg	lbs.	kg	lbs.	kg	in.	mm	in.	mm
LHT302 Base Unit	610	277	612	278	880	399	895	406	60	1524	37	940
LHT302 Max. Unit	693	315	696	316	1001	454	1018	462	60	1524	37	940

Base Unit - The unit with NO INTERNAL OPTIONS.

Max. Unit - The unit with ALL INTERNAL OPTIONS Installed. (Economizer, Standard Static Power Exhaust, Controls, etc.). Does not include accessories external to unit or high static power exhaust.

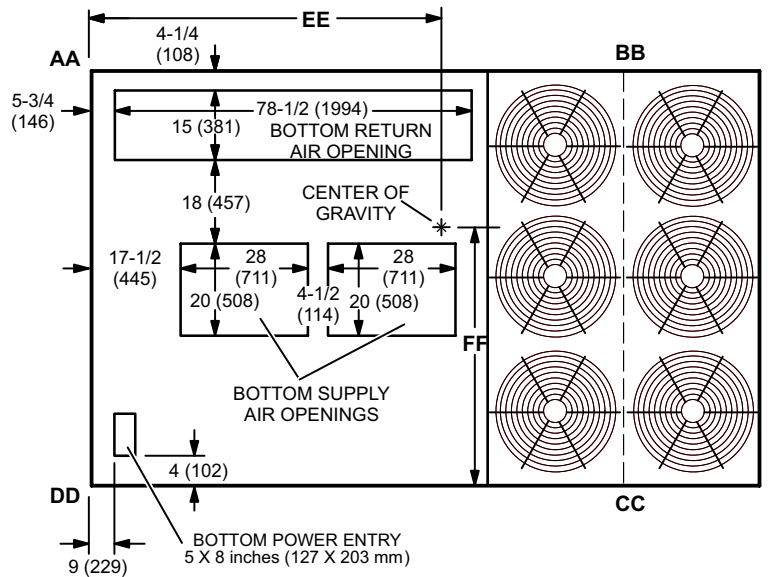

TOP VIEW

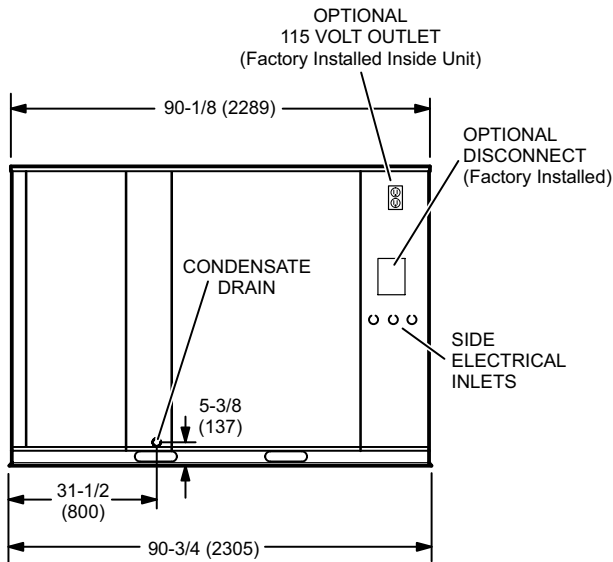

END VIEW

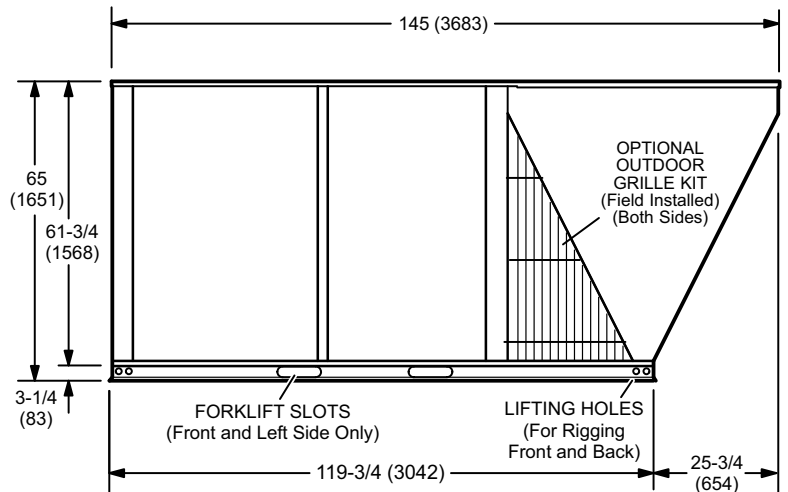

SIDE VIEW

OUTDOOR AIR HOOD DETAIL

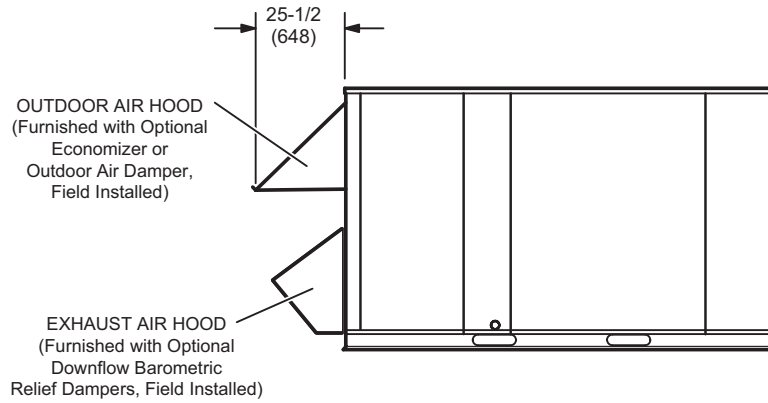

OPTIONAL HIGH STATIC POWER EXHAUST FANS DETAIL

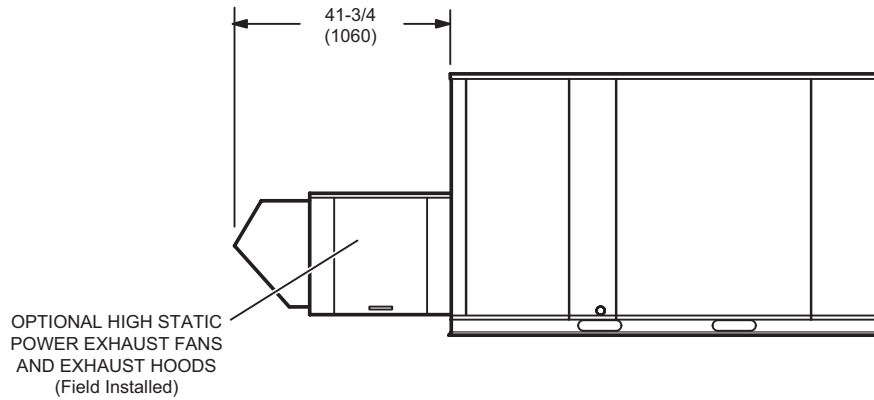

OPTIONAL HORIZONTAL BAROMETRIC RELIEF DAMPERS WITH HOOD

(Field installed in horizontal return air duct adjacent to unit)

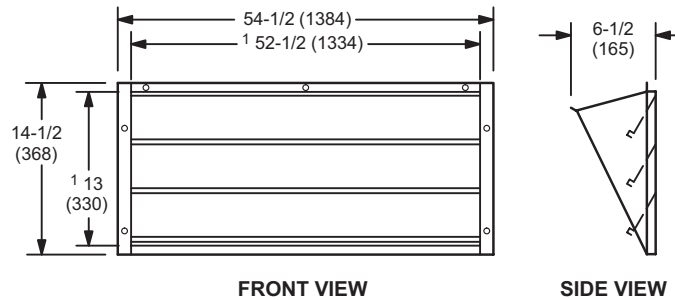

NOTE - Two furnished per order no.
 1 NOTE - Opening size required in return air duct.

ROOF CURBS WITH SUPPLY & RETURN AIR TRANSITIONS FOR CEILING DIFFUSERS

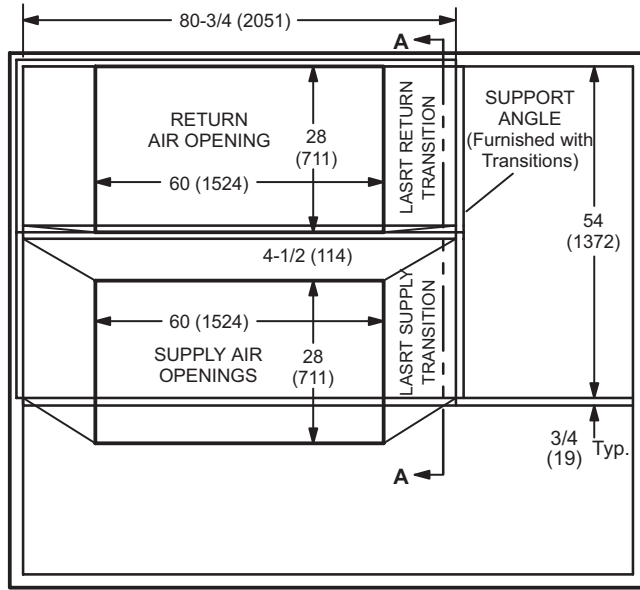

TOP VIEW

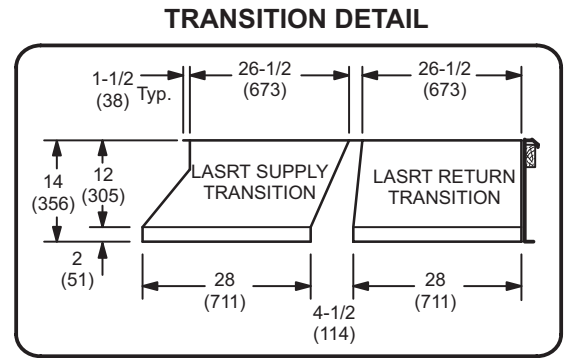

SECTION B-B

DIMENSIONS - ACCESSORIES

HORIZONTAL ROOF CURBS – Requires Optional Horizontal Return Air Panel Kit

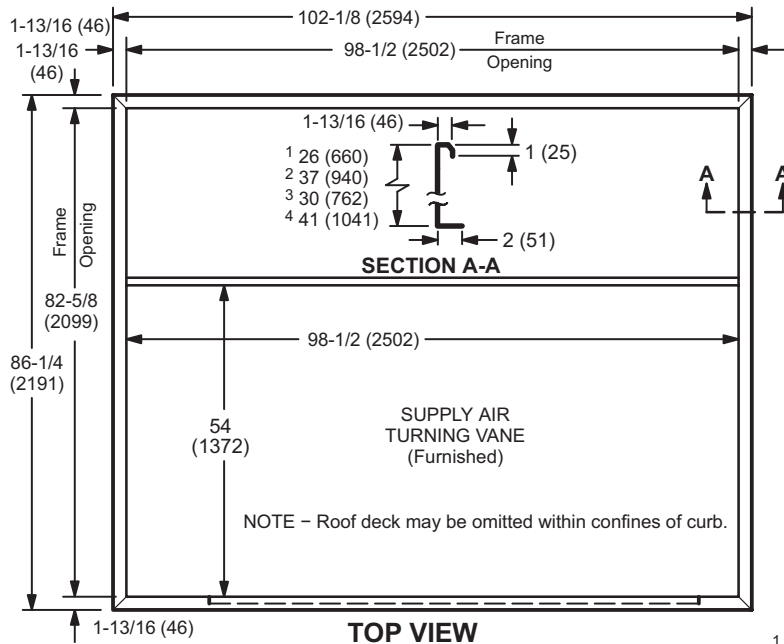

NOTE - 30 in. (762 mm) height Curb is designed for horizontal discharge when unit is mounted on a slab.
41 in. (1041 mm) height Curb is designed for horizontal discharge when unit is mounted on a rooftop.

PANEL TO COVER RETURN AIR OPENING IN BOTTOM OF UNIT (Furnished With Optional Horizontal Return Air Panel Kit)

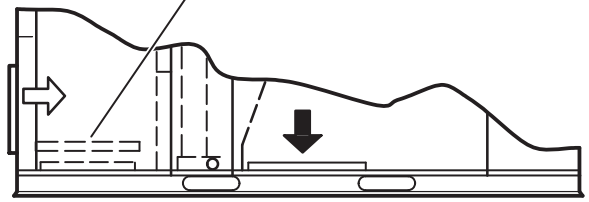

SIDE VIEW (PACKAGED UNIT)

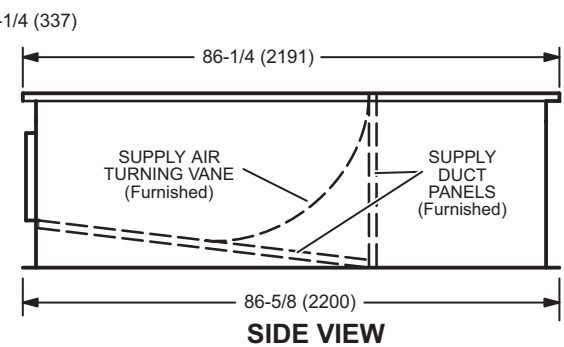
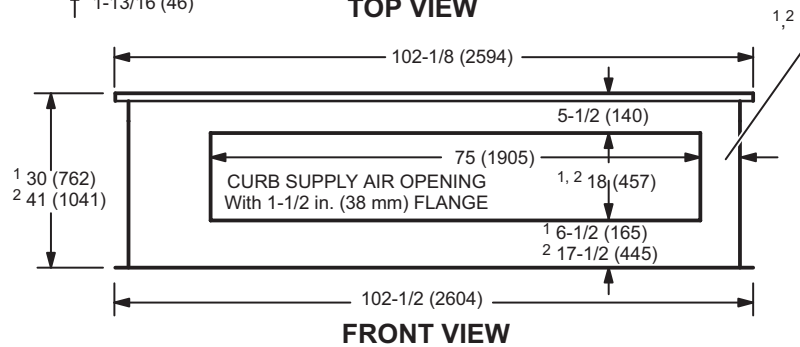

1 Slab Applications 2 Rooftop Applications

HORIZONTAL SUPPLY AND RETURN AIR OPENINGS ROOFTOP UNIT WITH HORIZONTAL ROOF CURB

1 Slab Applications
2 Rooftop Applications

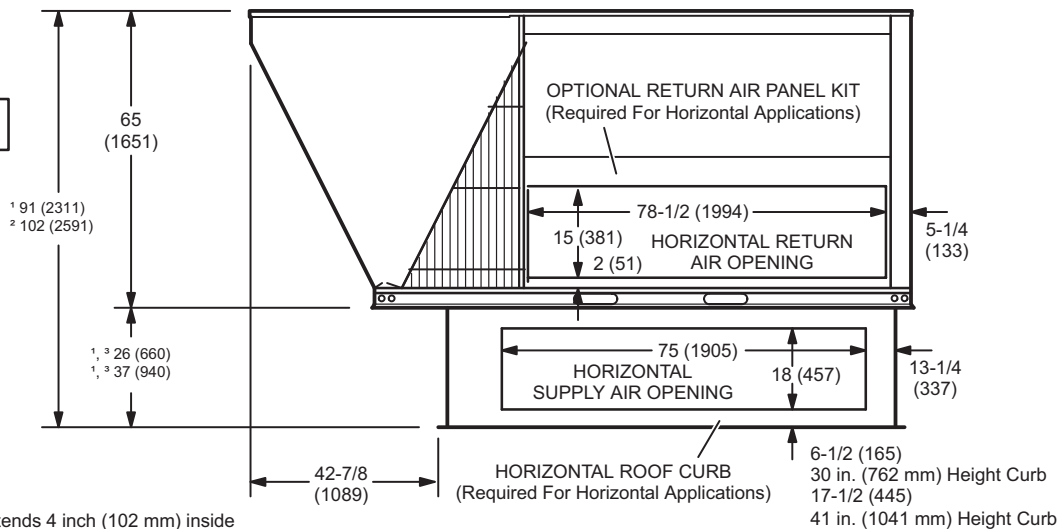

3 NOTE - Top of Curb extends 4 inch (102 mm) inside bottom of unit base. See Typical Flashing Detail.

DIMENSIONS - ACCESSORIES

COMBINATION CEILING SUPPLY AND RETURN DIFFUSERS

STEP-DOWN CEILING DIFFUSER

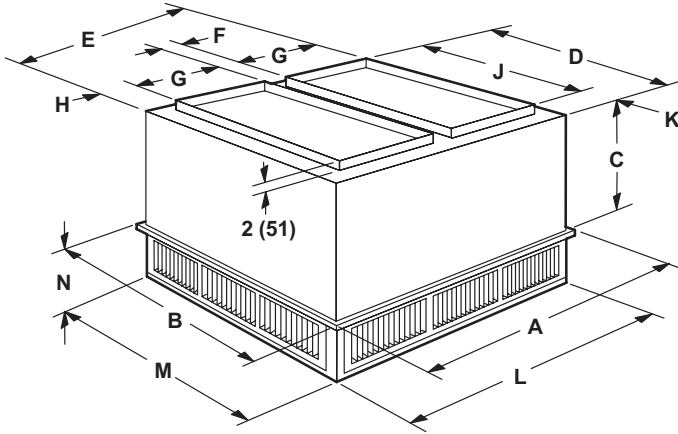

FLUSH CEILING DIFFUSER

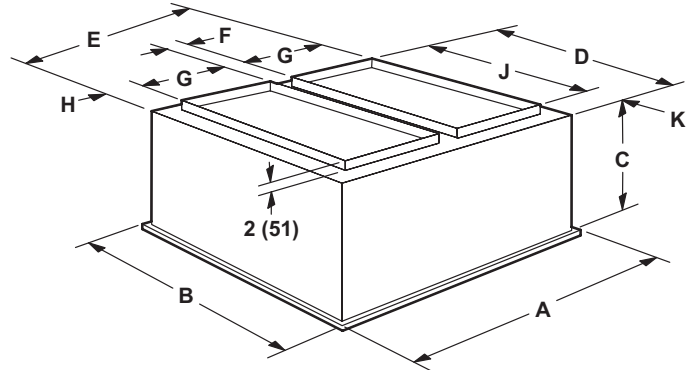

Model		LARTD30/36S
A	in.	65-5/8
	mm	1667
B	in.	65-5/8
	mm	1667
C	in.	40-1/2
	mm	1029
D	in.	63-1/2
	mm	1613
E	in.	63-1/2
	mm	1613
F	in.	4-1/2
	mm	114
G	in.	28
	mm	711
H	in.	1-1/2
	mm	38
J	in.	60
	mm	1524
K	in.	1-3/4
	mm	44
L	in.	63-1/2
	mm	1613
M	in.	63-1/2
	mm	1613
N	in.	12-1/8
	mm	308
Duct Size	in.	28 x 60
	mm	711 x 1524

Model		LAFD30/36S
A	in.	65-5/8
	mm	1667
B	in.	65-5/8
	mm	1667
C	in.	40
	mm	1016
D	in.	63-1/2
	mm	1613
E	in.	63-1/2
	mm	1613
F	in.	4-1/4
	mm	108
G	in.	28
	mm	711
H	in.	1-5/8
	mm	32
J	in.	60
	mm	1524
K	in.	1-3/4
	mm	44
Duct Size	in.	28 x 60
	mm	711 x 1524

REVISIONS

Sections	Description of Change
Electrical Accessories	Updated Disconnect Switch usage.



Visit us at www.Lennox.com

For the latest technical information, www.LennoxCommercial.com

Contact us at 1-800-4-LENNOX

NOTE - Due to Lennox' ongoing commitment to quality, Specifications, Ratings and Dimensions subject to change without notice and without incurring liability. Improper installation, adjustment, alteration, service or maintenance can cause property damage or personal injury. Installation and service must be performed by a qualified installer and servicing agency.

©2026 Lennox Industries, Inc.