

SL22KLV (R454B) SERIES OUTDOOR UNITS



Table of Contents

Model Number Identification.....	2
Specifications	3
Unit Dimensions – Inches (mm)	4
Typical Unit Parts Arrangement	5
Typical Plumbing Components	6
Operating Gauge Set and Service Valves	8
Installation	10
Removing and Installing Panels	16
New or Replacement Line Set.....	17
Brazing Connections	21
Flushing Line Set and Indoor Coil	24
Leak Testing the System	26
Evacuating Line Set and Indoor Coil	27
Unit Operation	30
EEV Valve and Controller	34
EEV Controller Diagnostics	35
Compressor Liquid Injection.....	37
Servicing Units Delivered Void of Charge	41
Unit Start-Up	41
System Operation and Service	42
Unit Selection Code for Outdoor Control	49
Configuring Unit.....	52
Reconfiguring Outdoor Control using	53
S40 Smart Wi-Fi Thermostat.....	53
System Overview.....	53
Diagnostic Information – Installations with S40 Smart Wi-Fi Thermostat	53
Installer Test –	53
Defrost Function	54
Maintenance.....	56
Unit Wiring Diagrams.....	57
Factory Wiring Diagrams.....	58
Unit Sequence of Operation	59
Component Testing.....	63
System Configuration	79
Unit Operation	79
Heat Pump Heating Mode	79
Emergency 24VAC System Operation	80
6-Pin Sensor Harness (COIL, AMB, LIQ/DIS)	81
System Refrigerant.....	92
SL22KLV Advanced Diagnostics	98

⚠ WARNING

Improper installation, adjustment, alteration, service or maintenance can cause property damage, personal injury or loss of life. Installation and service must be performed by a licensed professional HVAC installer or equivalent, service agency, or the gas supplier.

⚠ WARNING

- To prevent serious injury or death:
1. Lock-out/tag-out before performing maintenance.
 2. If system power is required (e.g., smoke detector maintenance), disable power to blower, remove fan belt where applicable, and ensure all controllers and thermostats are set to the “OFF” position before performing maintenance.
 3. Always keep hands, hair, clothing, jewelry, tools, etc. away from moving parts.

⚠ CAUTION

As with any mechanical equipment, contact with sharp sheet metal edges can result in personal injury. Take care while handling this equipment and wear gloves and protective clothing.

⚠ WARNING



Electric Shock Hazard. Can cause injury or death. Unit must be properly grounded in accordance with national and local codes. Line voltage is present at all components when unit is not in operation on units with single-pole contactors. Disconnect all remote electric power supplies before opening access panel. Unit may have multiple power supplies.

⚠ IMPORTANT

Where electrical components are being changed, they shall be fit for the purpose and to the correct specification. At all times the manufacturer’s maintenance and service guidelines shall be followed. If in doubt, consult the manufacturer’s technical department for assistance.

General Information

These instructions are intended as a general guide and do not supersede national or local codes in any way. Consult authorities having jurisdiction before installation.

The SL22KLV is a high-efficiency split system air conditioner **with all-aluminum coil**, designed for use with R454B refrigerant only.

The SL22KLV models feature a variable capacity R-scroll compressor.

This unit must be installed with an approved indoor air handler or coil. For AHRI Certified system match-ups and expanded ratings, visit www.LennoxPros.com. These instructions are intended as a general guide and do not supersede local codes in any way. Consult authorities having jurisdiction before installation.

This outdoor unit is designed for use in systems that use the following refrigerant metering device:

- Check thermal expansion valve (CTXV)

IMPORTANT: Special procedures are required for cleaning the all-aluminum coil in this unit.

! IMPORTANT

This unit must be matched with an indoor coil as specified with AHRI. For AHRI Certified system match-ups and expanded ratings, visit www.LennoxPros.com. Coils previously charged with HCFC-22 must be flushed.

! IMPORTANT

The Clean Air Act of 1990 bans the intentional venting of refrigerant (CFCs, HCFCs and HFCs) as of July 1, 1992. Approved methods of recovery, recycling or reclaiming must be followed. Fines and/or incarceration may be levied for noncompliance.

! WARNING



Electrical Hazard

High Voltage

Wait 7 Minutes

Electrical components may hold charge. Do not remove this panel or service this area for 5 minutes after the power has been removed.

Model Number Identification

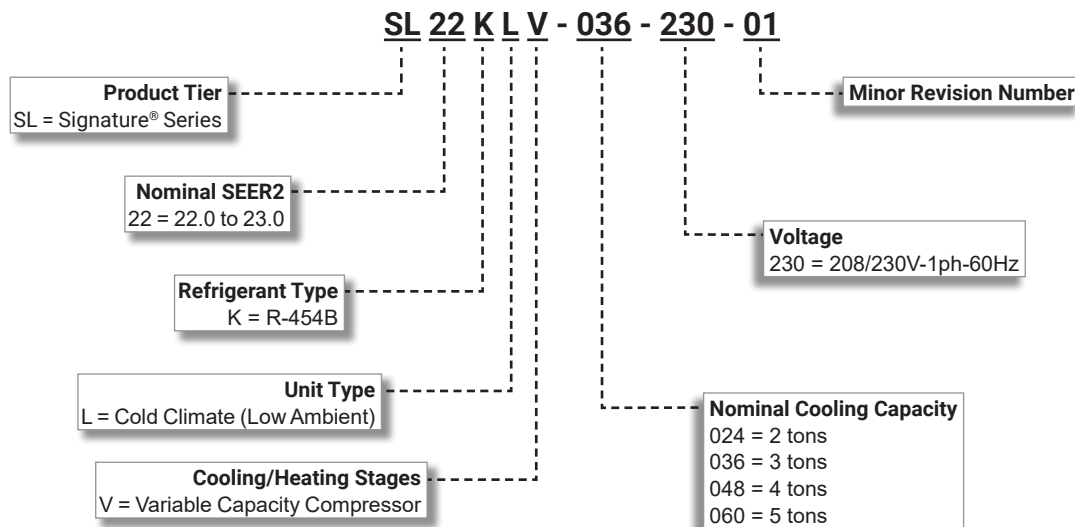

Typical Serial Number Identification

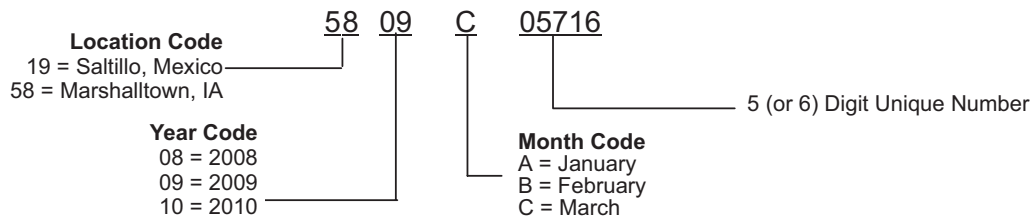

SPECIFICATIONS

Size		024	036	048	060	
Nominal Tonnage		2	3	4	5	
Sound Rating Number Range	dB	58-71	61-72	61-74	59-76	
Connections (Sweat)	Liquid line (OD) - in.	3/8	3/8	3/8	3/8	
	Suction line (OD) - in.	7/8	7/8	7/8	1-1/8	
Compressor Type		Variable Scroll	Variable Scroll	Variable Scroll	Variable Scroll	
Refrigerant (15 ft. Line Set)	¹ R-454B charge furnished	10 lbs. 13 oz.	16 lbs. 13 oz.	16 lbs. 13 oz.	16 lbs. 6 oz.	
Refrigerant (30 ft. Line Set)	¹ R-454B charge furnished	11 lbs. 6 oz.	17 lbs. 6 oz.	17 lbs. 6 oz.	16 lbs. 11 oz.	
Indoor Unit Expansion Valve (TXV)		26Z70	26Z70	26Z71	26Z72	
Outdoor Coil	Net face area - ft. ²	Outer coil	30.9	30.9	30.9	30.9
		Inner coil	- - -	29.94	29.94	29.94
	Tube diameter - in.	5/16	5/16	5/16	5/16	
	Rows	1	2	2	2	
	Fins - in.	22	22	22	22	
Outdoor Fan	HP	1/3	1/3	1/3	1/3	
	Diameter - in.	28	28	28	28	
	Blades	2	2	2	2	
	Cfm - Max. Speed	4121	4595	4595	4799	
	Min. Speed	1540	2305	3158	2305	
	Rpm - Max. Speed	689	775	775	818	
	Min. Speed	255	382	513	382	
	Watts - Max. Speed	116	159	159	193	
Min. Speed	9	24	52	24		
Shipping Data - lbs.		266	316	318	318	

ELECTRICAL DATA

	Line voltage data (Volts-Phase-Hz)	208/230-1-60	208/230-1-60	208/230-1-60	208/230-1-60
	² Maximum overcurrent protection (MOCP) amps	25	40	50	60
	³ Minimum circuit ampacity (MCA)	15.5	23.5	31.8	34.8
Compressor	Inverter Input Current Amps	10.3	16.63	23.4	25.7
Fan Motor	Full load amps	2.6	2.6	2.6	2.6

OPTIONAL ACCESSORIES - ORDER SEPARATELY

⁴ Freezestat	3/8 in.	93G35	•	•	•	•
⁵ Refrigerant Line Sets	3/8 x 7/8 3/8 30 ft.	89J60	•	•	•	
	3/8 x 7/8 3/8 50 ft.	89J62				
Liquid x Suction OD Insulation Thickness Length	3/8 x 1-1/8 3/8 50 ft.	73P91				•
Stand-Off Guard-Edge Raiser Kit	3 in. (76 mm)	27X34	•	•	•	•
	6 in. (152 mm)	27X35	•	•	•	•

NOTE - Extremes of operating range are plus 10% and minus 5% of line voltage.

¹ Refrigerant charge sufficient for the line set length listed in parenthesis. For longer line set requirements see the Installation Instructions or unit Charging Label for information about line set length and additional refrigerant charge required.

² HACR type breaker or fuse.

³ Refer to National or Canadian Electrical Code manual to determine wire, fuse and disconnect size requirements.

⁴ Freezestat is recommended for Low Ambient operation.

⁵ Refer to the Installation Instructions or Service Literature for Line Set Requirements and Refrigerant Piping Guidelines.

Unit Dimensions – Inches (mm)

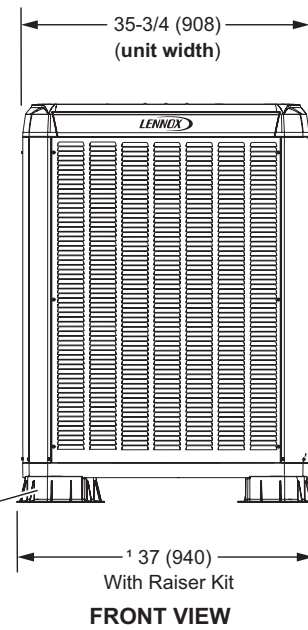
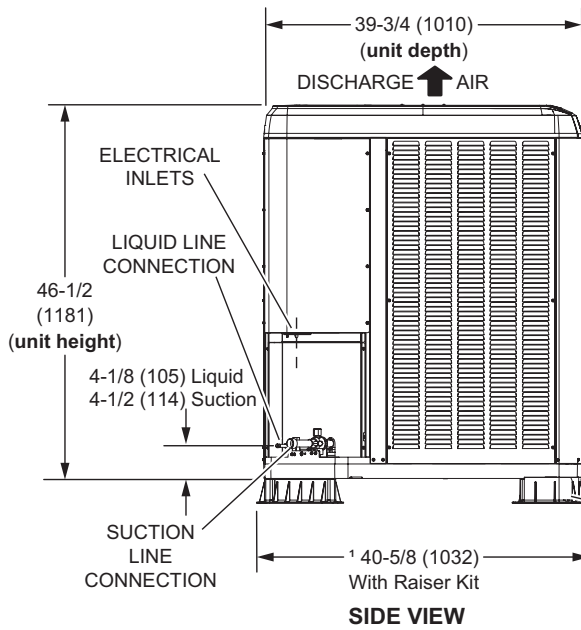
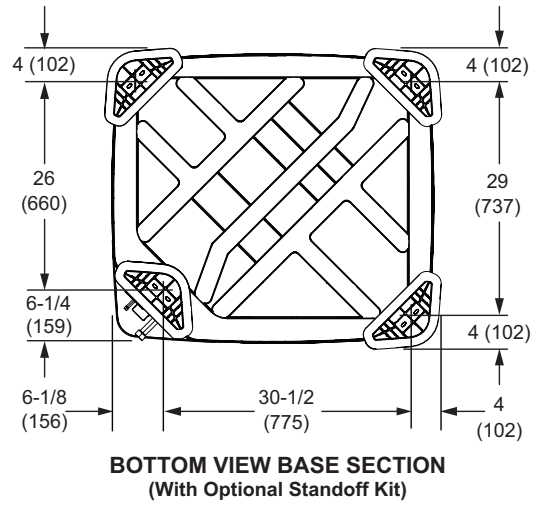
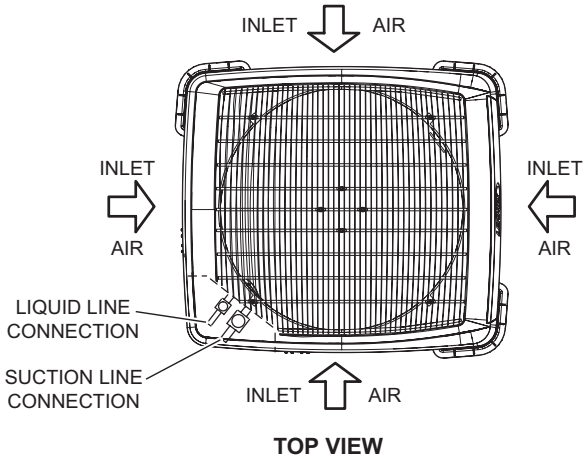

¹ OPTIONAL STAND-OFF GUARD-EDGE RAISER KIT (4) (Field Installed)

¹ Adds 3 in. (76 mm) or 6 in. (152 mm) to unit height
Adds 1-1/4 in. (32 mm) to unit width and depth

Typical Unit Parts Arrangement

CONTROL PANEL SL22KLV-024, -036

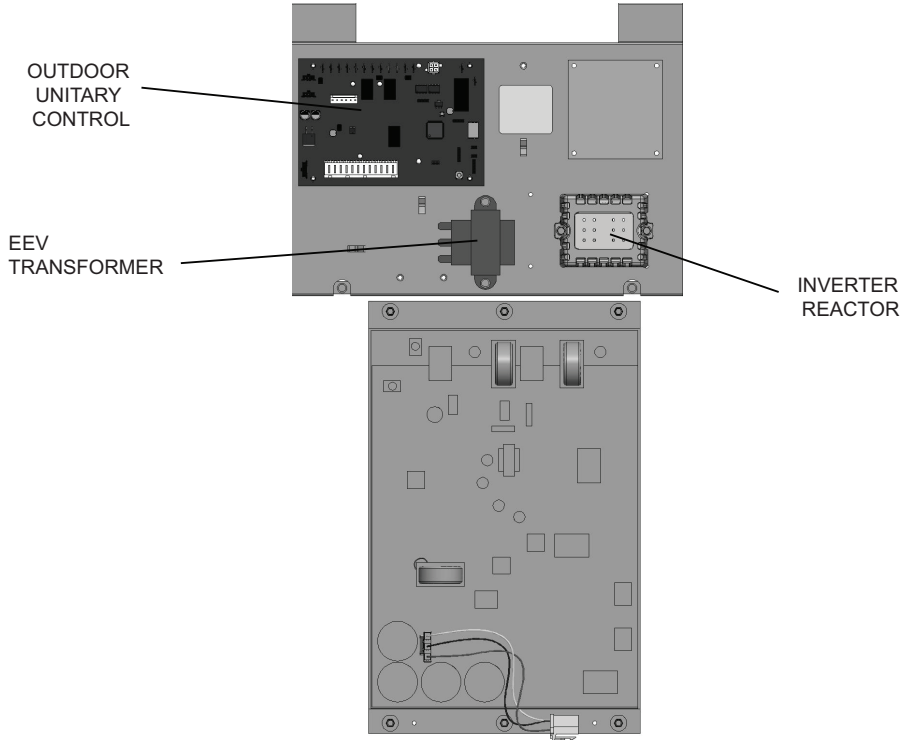

CONTROL PANEL SL22KLV-048, -060

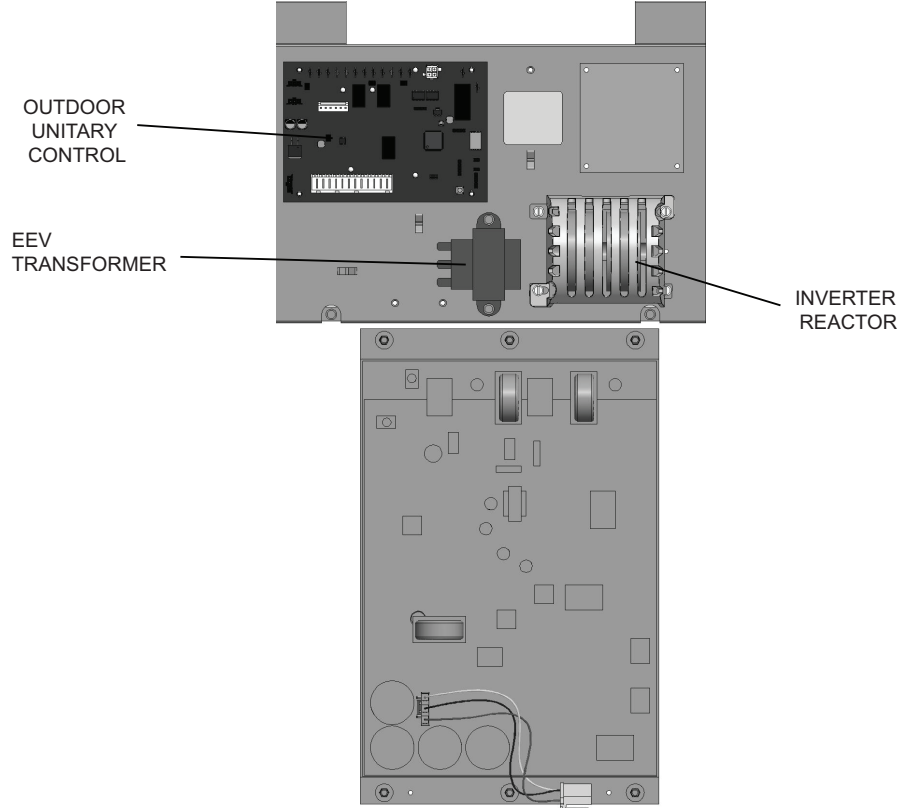

FIGURE 1. Control Panel Components

TYPICAL PLUMBING COMPONENTS

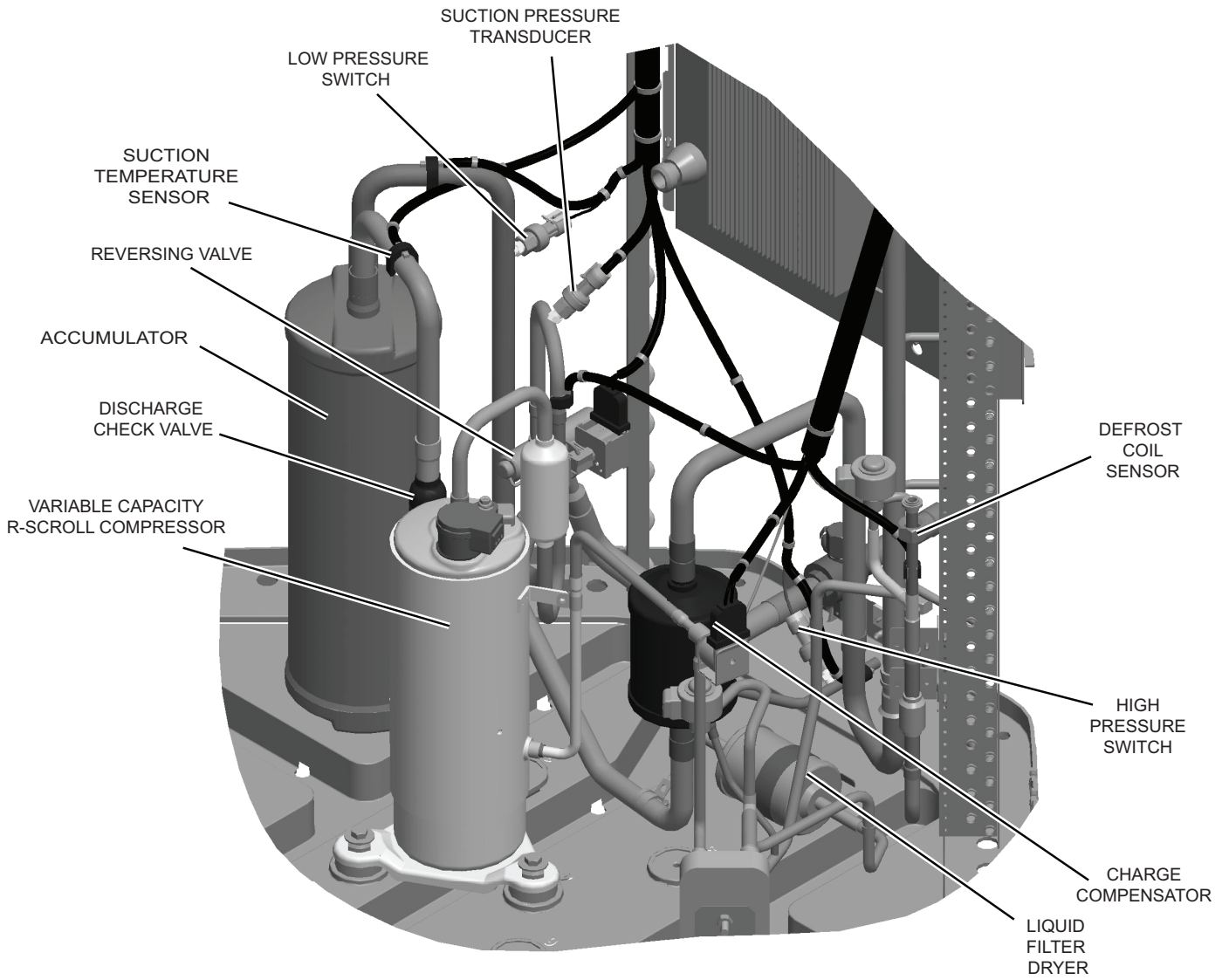

FIGURE 2. Component Locations – SL22KLV

TYPICAL PLUMBING COMPONENTS

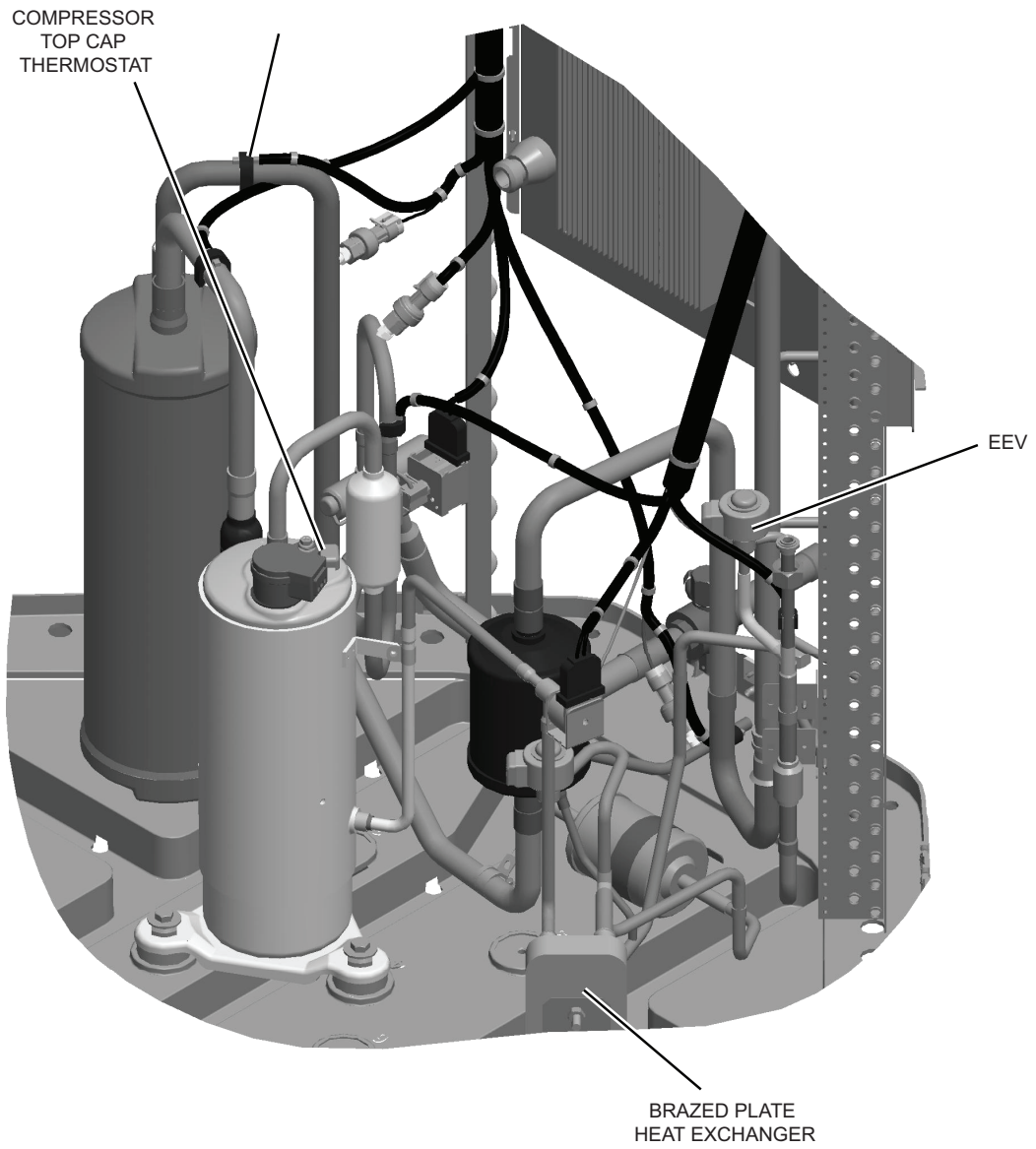

FIGURE 3. Component Locations – SL22KLV (Cont'd.)

Operating Gauge Set and Service Valves

TORQUE REQUIREMENTS

When servicing or repairing heating, ventilating, and air conditioning components, ensure the fasteners are appropriately tightened. Table 1 lists torque values for fasteners.

IMPORTANT

Only use Allen wrenches of sufficient hardness (50Rc - Rockwell Harness Scale minimum). Fully insert the wrench into the valve stem recess.

Service valve stems are factory-torqued (from 9 ft-lbs for small valves, to 25 ft-lbs for large valves) to prevent refrigerant loss during shipping and handling. Using an Allen wrench rated at less than 50Rc risks rounding or breaking off the wrench, or stripping the valve stem recess.

See the Lennox Service and Application Notes #C-08-1 for further details and information.

IMPORTANT

To prevent stripping of the various caps used, the appropriately sized wrench should be used and fitted snugly over the cap before tightening.

TABLE 1. Torque Requirements

Parts	Recommended Torque	
Service valve cap	8 ft.- lb.	11 NM
Sheet metal screws	16 ft.- lb.	2 NM
Machine screws #10	28 ft.- lb.	3 NM
Compressor bolts	90 in.- lb.	10 NM
Gauge port seal cap	8 ft.- lb.	11 NM

USING MANIFOLD GAUGE SET

When checking the system charge, only use a manifold gauge set that features low loss anti-blow back fittings.

Manifold gauge set used with R454B refrigerant systems must be capable of handling the higher system operating pressures. The gauges should be rated for use with pressures of 0 - 800 psig on the high side and a low side of 30" vacuum to 250 psig with dampened speed to 500 psi. Gauge hoses must be rated for use at up to 800 psig of pressure with a 4000 psig burst rating.

OPERATING SERVICE VALVES

The liquid and vapor line service valves are used for removing refrigerant, flushing, leak testing, evacuating, checking charge and charging. Each valve is equipped with a service port which has a factory-installed valve stem. Figure 5 provides information on access and operation of both angle and ball service valves

SERVICE VALVES ANGLE AND BALL

Operating Angle Type Service Valve:

1. Remove stem cap with an appropriately sized wrench.
2. Use a service wrench with a hex-head extension (3/16" for liquid line valve sizes and 5/16" for vapor line valve sizes) to back the stem out counterclockwise as far as it will go.

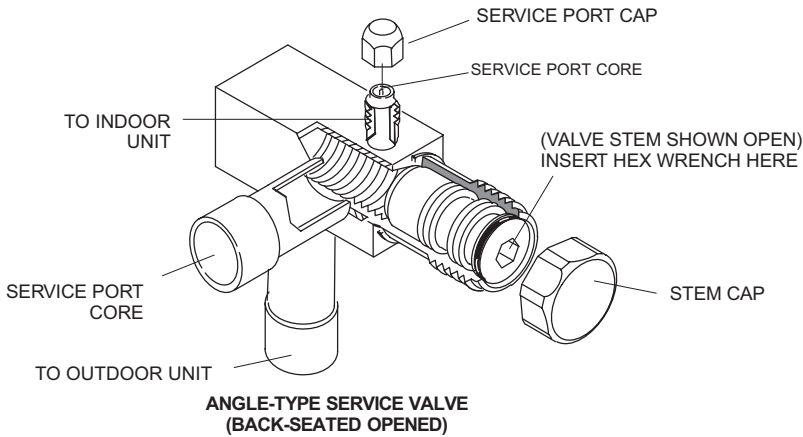

When service valve is **OPEN**, the service port is open to line set, indoor and outdoor unit.

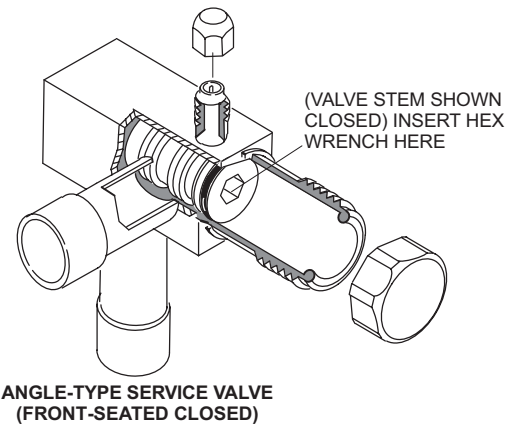

WHEN SERVICE VALVE IS **CLOSED**, THE SERVICE PORT IS OPEN TO THE LINE SET AND INDOOR UNIT.

Operating Ball Type Service Valve:

1. Remove stem cap with an appropriately sized wrench.
2. Use an appropriately sized wrench to open. To open valve, rotate stem counterclockwise 90°. To close rotate stem clockwise 90°.

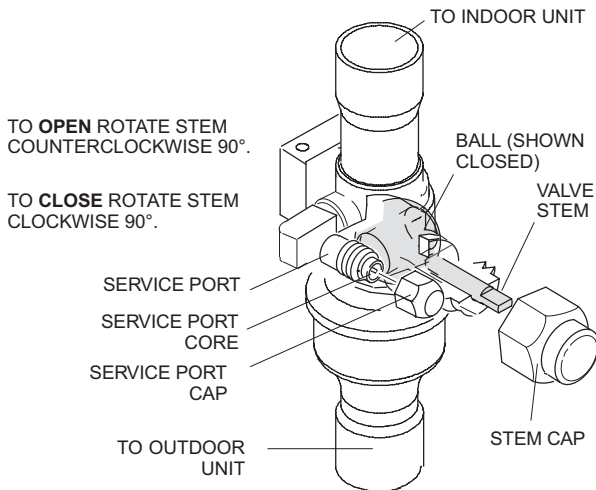

To Access Service Port:

A service port cap protects the service port core from contamination and serves as the primary leak seal.

1. Remove service port cap with an appropriately sized wrench.
2. Connect gauge set to service port.
3. When testing is completed, replace service port cap and tighten as follows:
 - With torque wrench: Finger tighten and torque cap per table 3.
 - Without torque wrench: Finger tighten and use an appropriately sized wrench to turn an additional 1/6 turn clockwise.

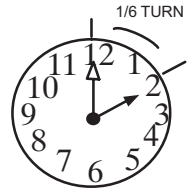

Reinstall Stem Cap:

Stem cap protects the valve stem from damage and serves as the primary seal. Replace the stem cap and tighten as follows:

- With Torque Wrench: Finger tighten and then torque cap per table 3.
- Without Torque Wrench: Finger tighten and use an appropriately sized wrench to turn an additional 1/12 turn clockwise.

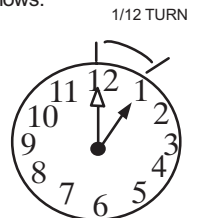

NOTE — A label with specific torque requirements may be affixed to the stem cap. If the label is present, use the specified torque.

FIGURE 4. Angle and Ball Service Valves

Installation

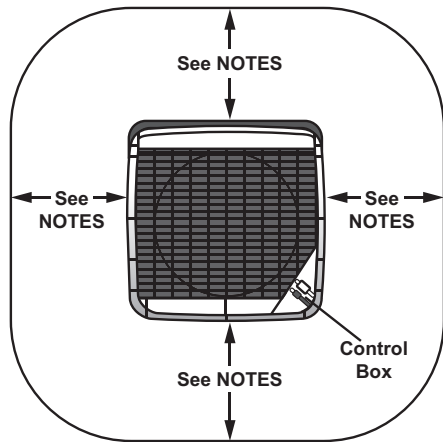

NOTES:

Service clearance of 30 in. (762 mm) must be maintained on one of the sides adjacent to the control box.

Clearance to one of the other three sides must be 36 in. (914 mm).

Clearance to one of the remaining two sides may be 12 in. (305 mm) and the final side may be 6 in. (152 mm).

A clearance of 24 in. (610 mm) must be maintained between two units.

48 in. (1219 mm) clearance required on top of unit.

NOTICE: Specific applications may require adjustment of the listed installation clearances to provide protection for the unit from physical damage or to avoid conditions which limit operating efficiency. (Example: Clearances may have to be increased to prevent snow or ice from falling on the top of the unit. Additional clearances may also be required to prevent air recirculation when the unit is installed under a deck or in another tight space.)

FIGURE 5. Installation Clearances

STABILIZING UNIT ON UNEVEN SURFACES

⚠ IMPORTANT

Unit Stabilizer Bracket Use (field-provided):

Always use stabilizers when unit is raised above the factory height. (Elevated units could become unstable in gusty wind conditions.)

Stabilizers may be used on factory height units when mounted on unstable an uneven surface..

- 1 - Remove the louvered panel from each side to expose the unit base.
- 2 - Install the brackets as illustrated in figure 8, detail D using conventional practices.
- 3 - Replace the panels after installation is complete.

ROOF MOUNTING

Locate the unit above a load-bearing wall or area of the roof that can adequately support the unit. Consult local codes for rooftop applications.

⚠ NOTICE

Roof Damage!

This system contains both refrigerant and oil. Some rubber roofing material may absorb oil, causing the rubber to swell. Bubbles in the rubber roofing material can cause leaks. Protect the roof surface to avoid exposure to refrigerant and oil during service and installation. Failure to follow this notice could result in damage to roof surface.

⚠ WARNING

- Do not use means to accelerate the defrosting process or to clean, other than those recommended by the manufacturer.
- The appliance shall be stored in a room without continuously operating ignition sources (for example: open flames, an operating gas appliance, or an operating electric heater).
- Do not pierce or burn.
- Be aware that refrigerants may not contain an odor.

⚠ WARNING

Every working procedure that affects safety means shall only be carried out by competent persons. This appliance is not to be used by persons (including children) with reduced physical, sensory or mental capabilities, or lack of experience and knowledge, unless they have been given supervision or instruction concerning use of the appliance by a person responsible for their safety. Children should be supervised to ensure they do not play with the appliance.

⚠ CAUTION

Some soaps used for leak detection are corrosive to certain metals. Carefully rinse piping thoroughly after leak test has been completed. Do not use matches, candles, flame or other sources of ignition to check for gas leaks.

⚠ CAUTION

Under no circumstances shall potential sources of ignition be used in the searching for or detection of refrigerant leaks. A halide torch (or any other detector using a naked flame) shall not be used. The following leak detection methods are deemed acceptable for all refrigerant systems. Electronic leak detectors may be used to detect refrigerant leaks but, in the case of flammable refrigerants, the sensitivity may not be adequate, or may need recalibration. (Detection equipment shall be calibrated in a refrigerant-free area.) Ensure that the detector is not a potential source of ignition and is suitable for the refrigerant used. Leak detection equipment shall be set at a percentage of the LFL of the refrigerant and shall be calibrated to the refrigerant employed, and the appropriate percentage of gas (25 % maximum) is confirmed. Leak detection fluids are also suitable for use with most refrigerants but the use of detergents containing chlorine shall be avoided as the chlorine may react with the refrigerant and corrode the copper pipe-work. If a leak is suspected, all naked flames shall be removed/extinguished. If a leakage of refrigerant is found which requires brazing, all of the refrigerant shall be recovered from the system, or isolated (by means of shut off valves) in a part of the system remote from the leak.

⚠ IMPORTANT

After completion of field piping for split systems, the field pipework shall be pressure tested with an inert gas and then vacuum tested prior to refrigerant charging, according to the following requirements;

– Field-made refrigerant joints indoors shall be tightness tested. The test method shall have a sensitivity of .2 oz. per year of refrigerant or better, under pressure. No leak shall be detected.

⚠ CAUTION

Service shall be performed only as recommended by the manufacturer.

⚠ WARNING

If this appliance is conditioning a space with an area smaller than T_{Amin} or stored in a space with an area smaller than T_{Amin} as defined by this instruction, then that space must be without continuously operating open flames (e.g. an operating gas appliance) or other potential ignition sources (e.g. an operating electric heater or similar hot surface). A flame-producing device may be installed in the same space if the device is provided with an effective flame arrest system.

TABLE 2
T_{Amin} Table

Charge (lb)	10	15	20	25	30
Charge (kg)	4.5	6.8	9.1	11.3	13.6
Minimum Conditioned Area (ft²)	150.9	226.4	301.9	377.4	452.8
Minimum Conditioned Area (m²)	14	21	28	35.1	42.1

NOTE – Multiply values in T_{Amin} table by the Altitude Adjustment Factors to correct T_{Amin} based on installed altitude.

TABLE 3
Q_{min} Table

Refrigerant Charge lb (kg)	CFM Required	Refrigerant Charge lb (kg)	CFM Required
5 (2.3)	135	18 (8.1)	487
6 (2.7)	162	19 (8.6)	514
7 (3.2)	189	20 (9.1)	541
8 (3.6)	216	21 (9.5)	568
9 (4.1)	244	22 (10)	595
10 (4.5)	271	23 (10.4)	622
11 (5)	298	24 (10.9)	649
12 (5.4)	325	25 (11.3)	676
13 (5.9)	352	26 (11.7)	704
14 (6.4)	379	27 (12.2)	731
15 (6.8)	406	28 (12.7)	758
16 (7.3)	433	29 (13.2)	785
17 (7.7)	460	30 (13.6)	812

TABLE 4
Altitude Adjustment Factor

Altitude	0	200	400	600	800	1000	1200	1400	1600
Adj. Factor	1	1	1	1	1.02	1.05	1.04	1.1	1.12
Altitude	1600	1800	2000	2200	2400	2600	2800	3000	3200
Adj. Factor	1.12	1.15	1.18	1.21	1.25	1.28	1.32	1.36	1.4

IMPORTANT

When breaking into the refrigerant circuit to make repairs – or for any other purpose – conventional procedures shall be used. However, for flammable refrigerants it is important that best practice be followed and, since flammability is a consideration, procedures such as safely remove refrigerant following local and national regulations, purging the circuit with inert gas, evacuating (optional for A2L), purging with inert gas (optional for A2L), or opening the circuit by cutting or brazing be adhered to. The refrigerant charge shall be recovered into the correct recovery cylinders if venting is not allowed by local and national codes. For appliances containing flammable refrigerants, the system shall be purged with oxygen-free nitrogen to render the appliance safe for flammable refrigerants.

This process might need to be repeated several times. Compressed air or oxygen shall not be used for purging refrigerant systems. For appliances containing flammable refrigerants, refrigerants purging shall be achieved by breaking the vacuum in the system with oxygen-free nitrogen and continuing to fill until the working pressure is achieved, then venting to atmosphere, and finally pulling down to a vacuum (optional for A2L). This process shall be repeated until no refrigerant is within the system (optional for A2L). When the final oxygen-free nitrogen charge is used, the system shall be vented down to atmospheric pressure to enable work to take place. Ensure that the outlet for the vacuum pump is not close to any potential ignition sources and that ventilation is available.

IMPORTANT

In addition to conventional charging procedures, the following requirements shall be followed.

- Ensure that contamination of different refrigerants does not occur when using charging equipment. Hoses or lines shall be as short as possible to minimize the amount of refrigerant contained in them.
- Cylinders shall be kept in an appropriate position according to the instructions.
- Ensure that the REFRIGERATING SYSTEM is earthed prior to charging the system with refrigerant.
- Label the system when charging is complete (if not already).
- Extreme care shall be taken not to overfill the REFRIGERATING SYSTEM.

Prior to recharging the system, it shall be pressure-tested with the appropriate purging gas. The system shall be leak tested on completion of charging, but prior to commissioning. A follow up leak test shall be carried out prior to leaving the site.

IMPORTANT

When removing refrigerant from a system, either for servicing or decommissioning, it is recommended good practice that all refrigerants are removed safely.

When transferring refrigerant into cylinders, ensure that only appropriate refrigerant recovery cylinders are employed. Ensure that the correct number of cylinders for holding the total system charge is available. All cylinders to be used are designated for the recovered refrigerant and labelled for that refrigerant (i. e. special cylinders for the recovery of refrigerant). Cylinders shall be complete with pressure-relief valve and associated shut-off valves in good working order. Empty recovery cylinders are evacuated and, if possible, cooled before recovery occurs.

The recovery equipment shall be in good working order with a set of instructions concerning the equipment that is at hand and shall be suitable for the recovery of all appropriate refrigerants including, when applicable, flammable refrigerants. In addition, a set of calibrated weighing scales shall be available and in good working order. Hoses shall be complete with leak-free disconnect couplings and in good condition. Before using the recovery machine, check that it is in satisfactory working order, has been properly maintained and that any associated electrical components are sealed to prevent ignition in the event of a refrigerant release. Consult manufacturer if in doubt.

The recovered refrigerant shall be returned to the refrigerant supplier in the correct recovery cylinder, and the relevant waste transfer note arranged. Do not mix refrigerants in recovery units and especially not in cylinders.

If compressors or compressor oils are to be removed, ensure that they have been evacuated to an acceptable level to make certain that flammable refrigerant does not remain within the lubricant. The evacuation process shall be carried out prior to returning the compressor to the suppliers. Only electric heating to the compressor body shall be employed to accelerate this process. When oil is drained from a system, it shall be carried out safely.

WARNING

Ducts connected to an appliance shall not contain a potential ignition source

IMPORTANT

Ensure that the area is in the open or that it is adequately ventilated before breaking into the system or conducting any hot work. A degree of ventilation shall continue during the period that the work is carried out.

⚠ IMPORTANT

Verify cabling will not be subject to wear, corrosion, excessive pressure, vibration, sharp edges or any other adverse environmental effects.

⚠ WARNING

PARTIAL UNITS shall only be connected to an appliance suitable for the same refrigerant.

⚠ CAUTION

As with any mechanical equipment, contact with sharp sheet metal edges can result in personal injury. Take care while handling this equipment and wear gloves and protective clothing.

⚠ IMPORTANT

Pipe work, including piping material, pipe routing, and installation shall include protection from physical damage in operation and service, and be in compliance with national and local codes and standards, such as ASHRAE 15, ASHRAE 15.2, UL 207, IAPMO Uniform Mechanical Code, ICC International Mechanical Code, or CSA B52. All field joints shall be accessible for inspection prior to being covered or enclosed.

NOTICE!

Charging information is given on the charging procedure sticker on the unit access panel. For more in-depth information, consult the Installation and Service Procedures manual, available on LennoxPros.com or through the Technical Support department at 800-453-6669.

⚠ IMPORTANT

Prior to beginning work on systems containing FLAMMABLE REFRIGERANTS, safety checks are necessary to ensure that the risk of ignition is minimized.

⚠ IMPORTANT

Work shall be undertaken under a controlled procedure so as to minimize the risk of a flammable gas or vapor being present while the work is being performed.

⚠ IMPORTANT

All maintenance staff and others working in the local area shall be instructed on the nature of work being carried out. Work in confined spaces shall be avoided.

⚠ IMPORTANT

The area shall be checked with an appropriate refrigerant detector prior to and during work, to ensure the technician is aware of potentially toxic or flammable atmospheres. Ensure that the leak detection equipment being used is suitable for use with all applicable refrigerants, i.e. non-sparking, adequately sealed or intrinsically safe.

⚠ IMPORTANT

If any hot work is to be conducted on the refrigerating equipment or any associated parts, appropriate fire extinguishing equipment shall be available to hand. Have a dry powder or CO² fire extinguisher adjacent to the charging area.

⚠ IMPORTANT

No person carrying out work in relation to a REFRIGERATING SYSTEM which involves exposing any pipe work shall use any sources of ignition in such a manner that it may lead to the risk of fire or explosion. All possible ignition sources, including cigarette smoking, should be kept sufficiently far away from the site of installation, repairing, removing and disposal, during which refrigerant can possibly be released to the surrounding space. Prior to work taking place, the area around the equipment is to be surveyed to make sure that there are no flammable hazards or ignition risks. "No Smoking" signs shall be displayed.

IMPORTANT

Where electrical components are being changed, they shall be fit for the purpose and to the correct specification. At all times the manufacturer's maintenance and service guidelines shall be followed. If in doubt, consult the manufacturer's technical department for assistance.

The following checks shall be applied to installations using FLAMMABLE REFRIGERANTS:

- the actual REFRIGERANT CHARGE is in accordance with the room size within which the refrigerant containing parts are installed;
- the ventilation machinery and outlets are operating adequately and are not obstructed;
- if an indirect refrigerating circuit is being used, the secondary circuit shall be checked for the presence of refrigerant;
- marking to the equipment continues to be visible and legible. Markings and signs that are illegible shall be corrected;
- refrigerating pipe or components are installed in a position where they are unlikely to be exposed to any substance which may corrode refrigerant containing components, unless the components are constructed of materials which are inherently resistant to being corroded or are suitably protected against being so corroded.

IMPORTANT

Sealed electrical components shall be replaced.

IMPORTANT

Intrinsically safe components must be replaced.

DETAIL A

INSTALL UNIT AWAY FROM WINDOWS

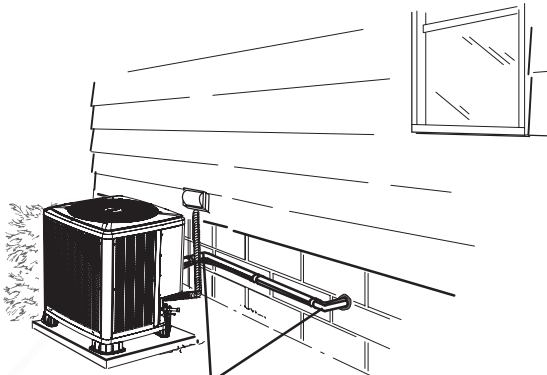

TWO 90° ELBOWS INSTALLED IN LINE SET WILL REDUCE LINE SET VIBRATION.

Outside Unit Placement

DETAIL B

INSTALL UNIT LEVEL OR, IF ON A SLOPE, MAINTAIN SLOPE TOLERANCE OF 2 DEGREES (OR 2 INCHES PER 5 FEET [50 MM PER 1.5 M]) AWAY FROM BUILDING STRUCTURE.

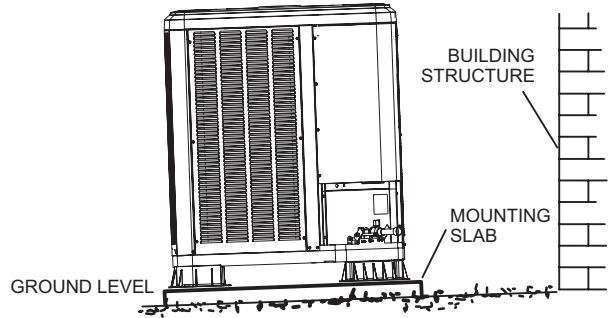

Slab Mounting at Ground Level

DETAIL C

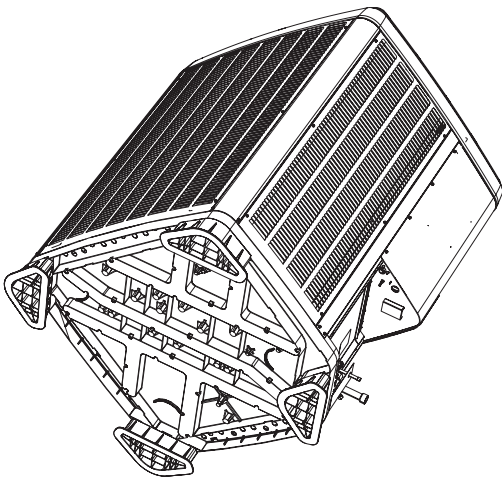

Underside of Unit Showing Optional Corner Post Raisers

DETAIL D

Slab Side Mounting

#10 1/2" LONG SELF-DRILLING SHEET METAL SCREWS

STABILIZING BRACKET (18 GAUGE METAL — 2" WIDTH; HEIGHT AS REQUIRED)

#10 1-1/4" LONG HEX HD SCREW AND FLAT WASHER

CONCRETE SLAB — USE TWO PLASTIC ANCHORS (HOLE DRILL 1/4")

WOOD OR PLASTIC SLAB — NO PLASTIC ANCHOR (HOLE DRILL 1/8")

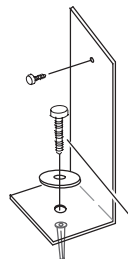
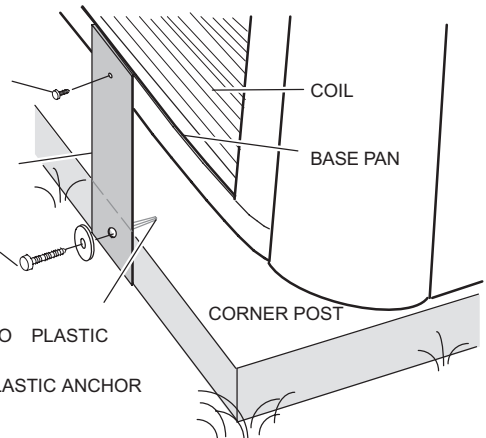

Deck Top Mounting

STABILIZING BRACKET (18 GAUGE METAL — 2" (50.8MM) WIDTH; HEIGHT AS REQUIRED); BEND TO FORM RIGHT ANGLE

SAME FASTENERS AS SLAB SIDE MOUNTING.

MINIMUM ONE PER SIDE

FOR EXTRA STABILITY

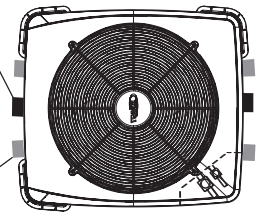

ONE BRACKET PER SIDE (MIN.); FOR EXTRA STABILITY, TWO BRACKETS PER SIDE, 2" (50.8MM) FROM EACH CORNER.

Stabilizing Unit on Uneven Surfaces

IMPORTANT — To help stabilize an outdoor unit, some installations may require strapping the unit to the pad using brackets and anchors commonly available in the marketplace.

FIGURE 6. Placement and Slab Mounting

Removing and Installing Panels

REMOVING AND INSTALLING LOUVERED PANELS



WARNING

TO PREVENT PERSONAL INJURY OR DAMAGE TO PANELS, UNIT OR STRUCTURE, BE SURE TO OBSERVE THE FOLLOWING:

WHILE INSTALLING OR SERVICING THIS UNIT, CAREFULLY STOW ALL REMOVED PANELS OUT OF THE WAY, SO THAT THE PANELS WILL NOT CAUSE INJURY TO PERSONNEL, NOR CAUSE DAMAGE TO OBJECTS OR STRUCTURES NEARBY, NOR WILL THE PANELS BE SUBJECTED TO DAMAGE (e.g., BEING BENT OR SCRATCHED).

WHILE HANDLING OR STOWING THE PANELS, CONSIDER ANY WEATHER CONDITIONS, ESPECIALLY WINDY CONDITIONS, THAT MAY CAUSE PANELS TO BE BLOWN AROUND AND BATTERED.

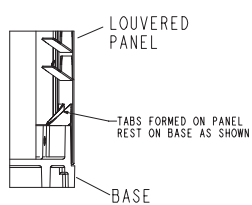

DETAIL A

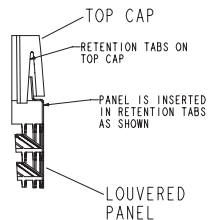

DETAIL B

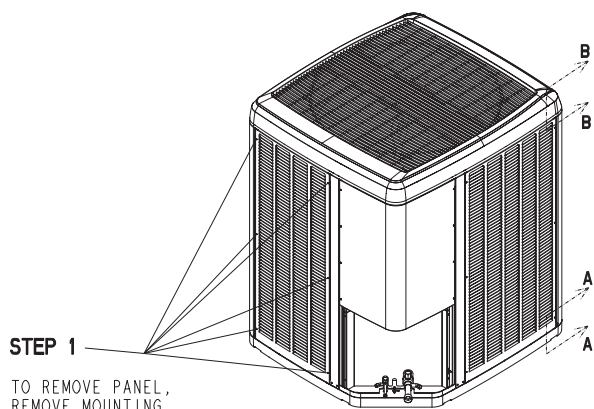

STEP 2

SLIGHTLY LIFT PANEL IN ORDER TO CLEAR SIDE LIPS OF PANEL FROM BASE UNIT.

STEP 3

TILT PANEL OUT SLIGHTLY AND PULL DOWNWARD TO REMOVE.

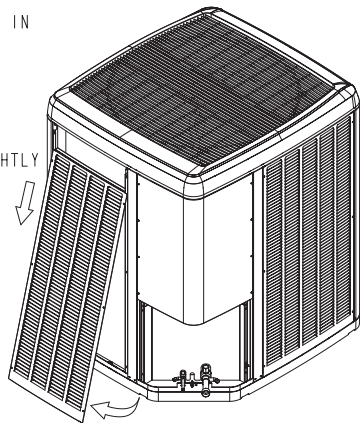

PANEL REMOVAL

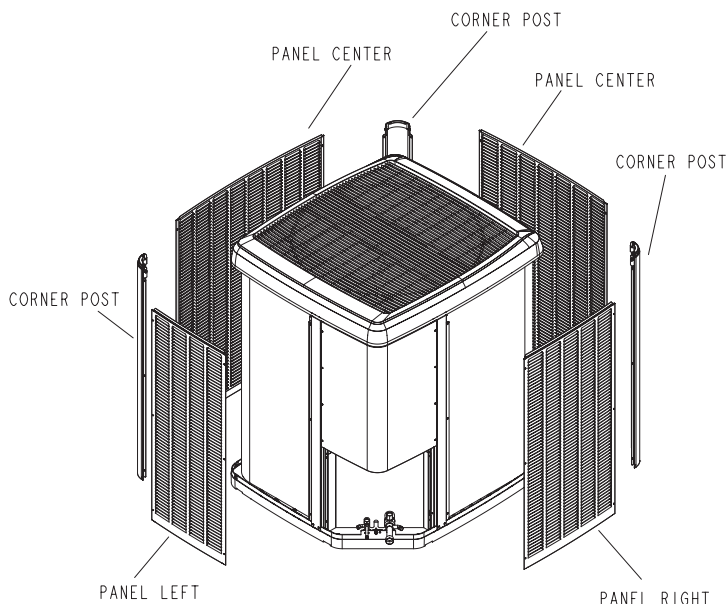

STEP 1

INSERT PANEL UNDER UNIT TOP CAP LIP AND LIFT SLIGHTLY TO CLEAR SIDE LIP OF PANEL FROM BASE.

STEP 2

MOVE PANEL IN TOWARDS UNIT. ALIGN LEFT/RIGHT SIDE LIPS OF PANEL WITH GROOVE INSERTS ALONG LEFT/RIGHT SIDE OF UNIT.

STEP 3

SECURE PANEL, WITH MOUNTING SCREWS.

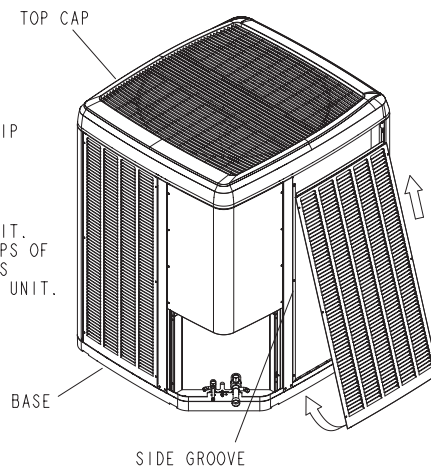

PANEL INSTALLATION

FIGURE 7. Removing and Installing Panels

New or Replacement Line Set

IMPORTANT

If this unit is being matched with an approved line set or indoor unit coil that was previously charged with mineral oil, or if it is being matched with a coil which was manufactured before January of 1999, the coil and line set must be flushed prior to installation. Take care to empty all existing traps. Polyvinyl ether (PVE) oils are used in Lennox units charged with R454B refrigerant. Residual mineral oil can act as an insulator, preventing proper heat transfer. It can also clog the expansion device and reduce system performance and capacity. Failure to properly flush the system per this instruction and the detailed Installation and Service Procedures manual will void the warranty.

Flush the existing line set per the following instructions. For more information, refer to the Installation and Service Procedures manual available on LennoxPros.com. **CAUTION - DO NOT** attempt to flush and re-use existing line sets or indoor coil when the system contains contaminants (i.e., compressor burn out).

If a new line set is being installed, size the piping per table 5.

TABLE 5

REFRIGERANT LINE SET – INCHES (MM)					
Model	Valve Field Connections		Recommended Line Set		
	Liquid Line	Vapor Line	Liquid Line	Vapor Line	L15 Line Sets
-024	3/8 in. (10 mm)	7/8 in. (22 mm)	3/8 in. (10 mm)	7/8 in. (22 mm)	L15-65 15 ft. - 50 ft. (4.6 m - 15 m)
-036	3/8 in. (10 mm)	7/8 in. (22 mm)	3/8 in. (10 mm)	7/8 in. (22 mm)	L15-65 15 ft. - 50 ft. (4.6 m - 15 m)
-048					
-060	3/8 in. (10 mm)	1-1/8 in. (28 mm)	3/8 in. (10 mm)	1-1/8 in. (28 mm)	Field Fabricated

NOTE - Some applications may require a field-provided 7/8" to 1-1/8" adapter.

NOTE - When installing refrigerant lines longer than 50 feet, refer to the Refrigerant Piping Design and Fabrication Guidelines manual available on LennoxPros.com (Corp. 9351-L9), or contact the Technical Support Department Product Application group for assistance.

Line Set Joints - Furnace Application

Evaporator primary line set joints in all applications shall have a line set joint sleeve.

Evaporator primary line sets should not have additional joints not covered by line set joint sleeve.

If additional joints are present, the system installation shall comply with one of the options below:

Option 1 - Furnace is installed as a direct vent appliance;

Option 2 - Furnace/Evaporator installation is in a space greater than the minimum conditioned area (Amin);

Option 3 - Furnace/Evaporator installation is connected to a space greater than the minimum conditioned area (Amin) through an opening of at least 15 in² (4-inch diameter hole equivalent) located below the level of the furnace burners;

Option 4 - Have a second refrigerant detection sensor installed below the level of the burners (see Secondary Sensor Installation section).

Multiple Systems Installed in Same Space

For any A2L refrigerant system with additional joints not covered by line set joint sleeves, each system in the same space must have refrigerant detection sensor installed below the level of the burners (see Secondary Sensor Installation section). If all the systems in the same space are installed with direct vent application, then additional refrigerant detection sensor is not needed

Secondary Sensor Installation

If secondary refrigerant sensor is required, it shall be mounted as follows:

Upflow Applications: Mounted on an unused side furnace return air connection at least 9 inches above the floor and within 9 inches from front of furnace.

Downflow Applications: Mounted on one side of the evaporator coil 9 inches above the floor and within 9 inches from front of coil.

Horizontal Applications: Mounted on the bottom side return furnace air connection within 9 inches of both the blower deck and front of furnace.

Connect the refrigerant sensor to the second sensor input on the RDS Control. Refer to the instructions provided with the sensor or the RDS controller to enable the second sensor.

IMPORTANT

The Clean Air Act of 1990 bans the intentional venting of refrigerant (CFCs, HCFCs and HFCs) as of July 1, 1992. Approved methods of recovery, recycling or reclaiming must be followed. Fines and/or incarceration may be levied for noncompliance.

WARNING



When using a high pressure gas such as nitrogen to pressurize a refrigeration or air conditioning system, use a regulator that can control the pressure down to 1 or 2 psig (6.9 to 13.8 kPa).

WARNING

Refrigerant can be harmful if it is inhaled. Refrigerant must be used and recovered responsibly.

Failure to follow this warning may result in personal injury or death.

⚠ WARNING



Fire, Explosion and Personal Safety hazard. Failure to follow this warning could result in damage, personal injury or death.

Never use oxygen to pressurize or purge refrigeration lines. Oxygen, when exposed to a spark or open flame, can cause fire and/or an explosion, that could result in property damage, personal injury or death.

⚠ WARNING

Polyvinyl ether (PVE) oils used with R454B refrigerant absorb moisture very quickly. It is very important that the refrigerant system be kept closed as much as possible. **DO NOT** remove line set caps or service valve stub caps until you are ready to make connections.

The SL22KLV is a variable-capacity cooling system utilizing variable speed compressor technology. With the variable speed compressor and variable pumping capacity, additional consideration must be given to refrigerant piping sizing and application. The guidelines below are to be used exclusively for the SL22KLV systems.

HEAT PUMP SYSTEM (R454B)

- Total equivalent length equals 180 feet (piping and all fittings included).

NOTE – Length is general guide. Lengths may be more or less, depending on remaining system design factors.

- Maximum linear (actual) length = 150 feet.
- Maximum linear liquid lift = 60 feet.

NOTE – Maximum lifts are dependent on total length, number of elbows, etc. that contribute to total pressure drop.

- Maximum length vapor riser = 60 feet.
- **Up to 50 Linear Feet:** Use rated line sizes listed in table 1.
- **Between 51 and 150 Linear Feet:** Crankcase heater and nonbleed port TXV factory installed. No additional components required. Vertical vapor riser must be sized to the vapor riser listed in the table 2 on systems with line sets longer than 51 feet. Use tables 2 and 3 to determine the correct liquid and vapor line sizes.
- **Over 150 Linear Feet:** not recommended.
- Additional oil is not required for systems with line lengths up to 150 feet.

SUCTION TRAPS

For systems with the outdoor unit 5 - 60 feet above the indoor unit, one trap must be installed at the bottom of the suction riser.

TABLE 6. Standard Refrigerant Line Set – Up to 50 Linear Feet in Length

Inches (mm)					
SL22KLV ¹	Valve Size Connections		Recommend Line Sets		
	Liquid Line	Suction Line	L15 Line Set Model	Line Set Length	Catalog Number
-024	3/8" (10 mm)	7/8" (22 mm)	L15-65-40	40 feet (12.2 m)	89J61
-036 -048	3/8" (10 mm)		L15-65-50	50 feet (15.2 m)	89J62
-060	3/8" (10 mm)	1-1/8" (29 mm) ²	Field-fabricated		

¹ Applicable to all minor revision numbers unless otherwise specified.

² Some applications may require a field-provided 1-1/8" to 7/8" adapter.

TABLE 7. SL22KLV Line Set Guidelines – 51 to 150 Linear Feet in Length

Model	Maximum Total Equivalent Length (ft)	Maximum Linear (actual) Length (ft)	Maximum Vapor Riser (ft)	Maximum Linear Liquid Lift (ft)	Preferred Vapor Line Sizes for Horizontal Runs	Required Vapor Riser Size
-024	180	150	60	60	7/8"	5/8"
-036	180	150	60	60	7/8"	3/4"
-048	180	150	60	60	7/8"	7/8"
-060	180	150	60	60	7/8"	7/8"

TABLE 8. Liquid Line Diameter Selection Table

Unit	Line Size	Total Linear Length (feet)						Max Elevation (ft)
		25	50	75	100	125	150	
-024	5/16"	25	50	55	48	40	33	
	3/8"	25	50	60	60	60	60	
-035	3/8"	25	50	60	56	51	45	
	1/2"	25	50	60	60	60	60	
-048	3/8"	25	50	50	41	31	22	
	1/2"	25	50	60	60	60	60	
-060	3/8"	25	50	36	22	8	NR	
	1/2"	25	50	60	60	60	59	

NOTE - Shaded rows indicate rated liquid line size.

- F. Find your unit on the left side of the table.
- G. Start with the rated liquid line size (shaded row) on the outdoor unit.
- H. Select the actual Total Linear Length of your system shown at the top of the table.
- I. The elevation listed in the table is the maximum allowed for the liquid line listed.
- J. Select or consider the larger liquid line size shown in the table if the elevation does not meet your requirements.

NOTE - For new or replacement set installation, refer to Service and Application Note - Corp. 9112-L4 (C-91-4).

⚠ CAUTION

Brazing alloys and flux contain materials which are hazardous to your health.
 Avoid breathing vapors or fumes from brazing operations. Perform operations only in well-ventilated areas.
 Wear gloves and protective goggles or face shield to protect against burns.
 Wash hands with soap and water after handling brazing alloys and flux.

⚠ WARNING



Danger of fire. Bleeding the refrigerant charge from only the high side may result in pressurization of the low side shell and suction tubing. Application of a brazing torch to a pressurized system may result in ignition of the refrigerant and oil mixture. Check the high and low pressures before applying heat.

LINE SET

IMPORTANT — Refrigerant lines must not contact structure.

INSTALLATION

Line Set Isolation — The following illustrations are examples of proper refrigerant line set isolation:

REFRIGERANT LINE SET — TRANSITION FROM VERTICAL TO HORIZONTAL

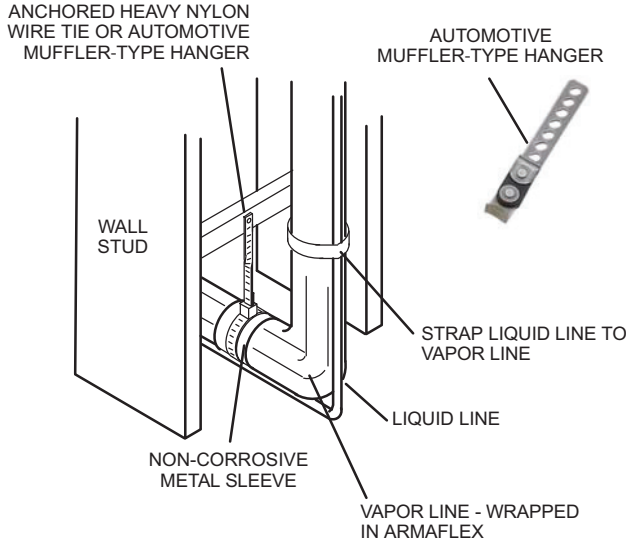

REFRIGERANT LINE SET — INSTALLING VERTICAL RUNS (NEW CONSTRUCTION SHOWN)

NOTE — Insulate liquid line when it is routed through areas where the surrounding ambient temperature could become higher than the temperature of the liquid line or when pressure drop is equal to or greater than 20 psig.

IMPORTANT — Refrigerant lines must not contact wall

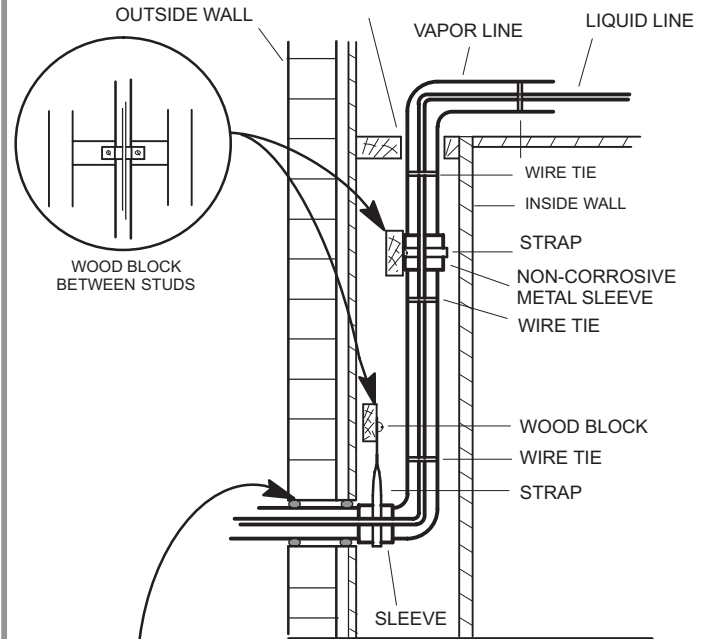

REFRIGERANT LINE SET — INSTALLING HORIZONTAL RUNS

To hang line set from joist or rafter, use either metal strapping material or anchored heavy nylon wire ties.

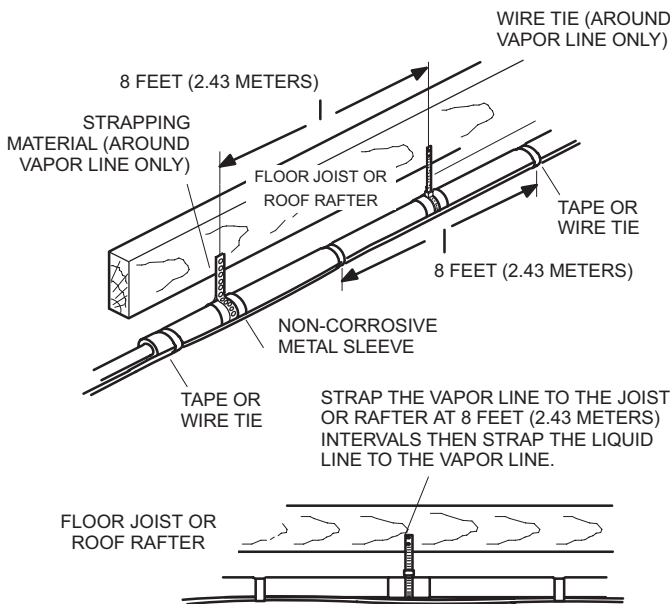

NOTE — Similar installation practices should be used if line set is to be installed on exterior of outside wall.

WARNING — Polyvinyl (PVE) oils used with R-454B refrigerant absorb moisture very quickly. It is very important that the refrigerant system be kept closed as much as possible. **DO NOT** remove line set caps or service valve stub caps until you are ready to make connections.

FIGURE 8. Line Set Installation

Brazing Connections

Use the procedures outlined in figures 11 and 12 for brazing line set connections to service valves.

WARNING



Danger of fire. Bleeding the refrigerant charge from only the high side may result in pressurization of the low side shell and suction tubing. Application of a brazing torch to a pressurized system may result in ignition of the refrigerant and oil mixture. Check the high and low pressures before applying heat.

WARNING



When using a high pressure gas such as nitrogen to pressurize a refrigeration or air conditioning system, use a regulator that can control the pressure down to 1 or 2 psig (6.9 to 13.8 kPa).

CAUTION

Brazing alloys and flux contain materials which are hazardous to your health.

Avoid breathing vapors or fumes from brazing operations. Perform operations only in well-ventilated areas.

Wear gloves and protective goggles or face shield to protect against burns.

Wash hands with soap and water after handling brazing alloys and flux.

IMPORTANT

Allow braze joint to cool before removing the wet rag from the service valve. Temperatures above 250°F can damage valve seals.

IMPORTANT

Use silver alloy brazing rods with 5% minimum silver alloy for copper-to-copper brazing. Use 45% minimum alloy for copper-to-brass and copper-to-steel brazing.

WARNING



Fire, Explosion and Personal Safety hazard. Failure to follow this warning could result in damage, personal injury or death.

Never use oxygen to pressurize or purge refrigeration lines. Oxygen, when exposed to a spark or open flame, can cause fire and/or an explosion, that could result in property damage, personal injury or death.

IMPORTANT

Braze-Free fittings must conform with UL207 or ISO 14903 (latest edition).

1 PIPING PANEL REMOVAL AND LINE SET PREPARATION

Remove piping panel for easier access to service valves. Cut ends of the refrigerant lines square (free from nicks or dents) and debur the ends. The pipe must remain round. Do not crimp end of the line.

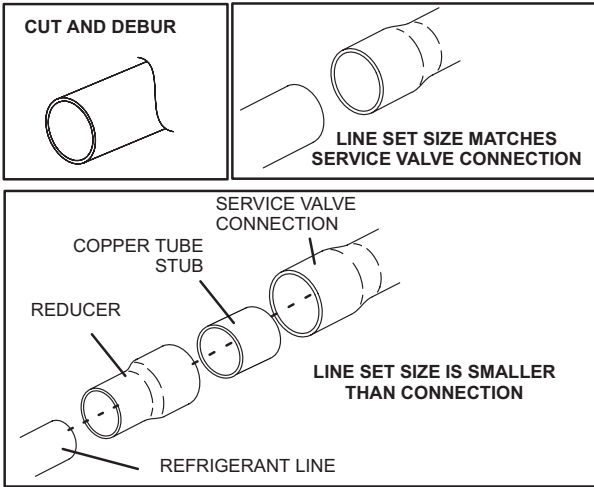

DO NOT CRIMP SERVICE VALVE CONNECTOR WHEN PIPE IS SMALLER THAN CONNECTION

2 CAP AND CORE REMOVAL

Remove service cap and core from both the suction and liquid line service ports.

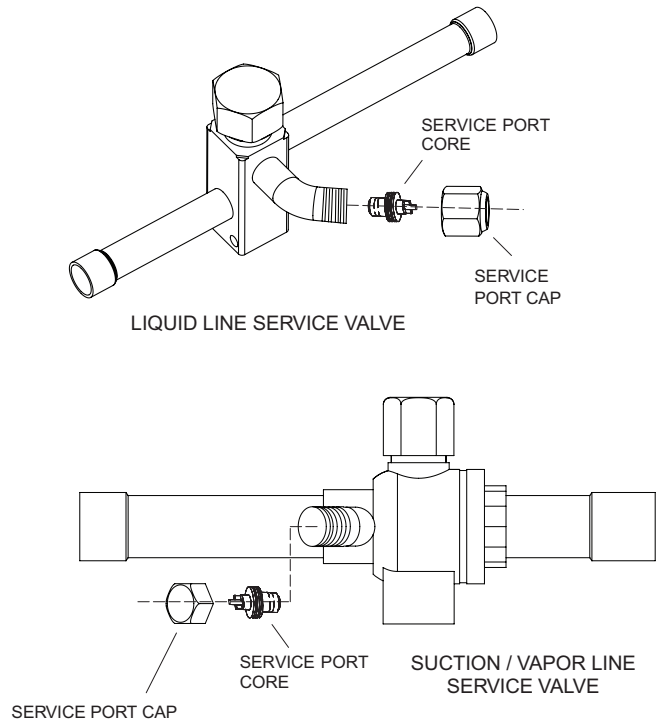

3 ATTACH THE MANIFOLD GAUGE SET FOR BRAZING LIQUID AND SUCTION LINE SERVICE VALVES

- A. Connect gauge set low pressure side to liquid line service valve (service port).
- B. Connect gauge set center port to bottle of nitrogen with regulator.
- C. With valve core removed from the suction line service port, nitrogen flow will have an exit point.

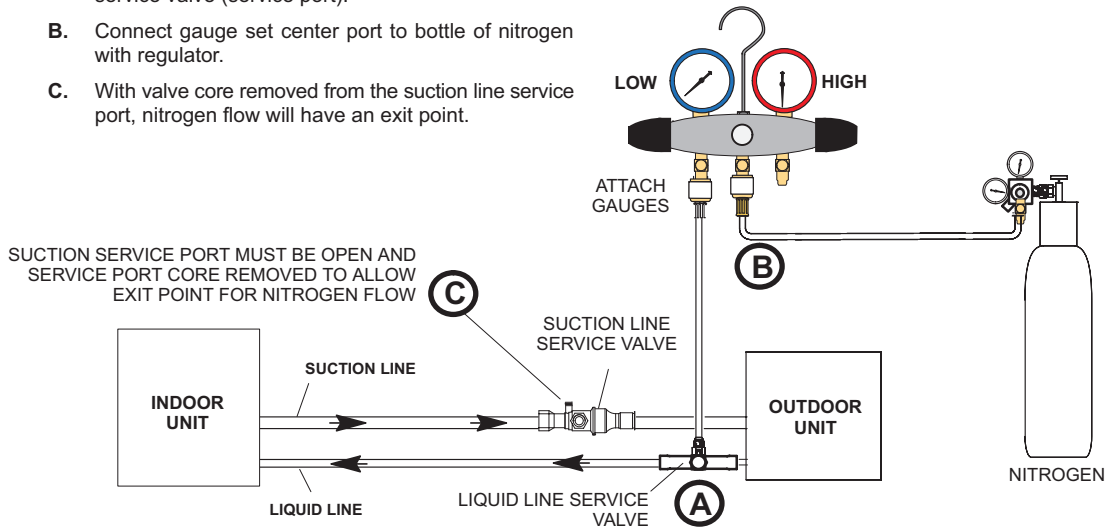

FIGURE 9. Brazing Procedures

4 WRAP SERVICE VALVES

To help protect service valve seals during brazing, wrap water-saturated cloths around service valve bodies and copper tube stubs. Use additional water-saturated cloths underneath the valve body to protect the base paint.

5 FLOW NITROGEN

Flow regulated nitrogen (at 1 to 2 psig) through the refrigeration gauge set into the valve stem port connection on the liquid service valve and out of the suction / vapor valve stem port. See steps 3A, 3B and 3C on manifold gauge set connections.

6 BRAZE LINE SET

Wrap both service valves with water-saturated cloths as illustrated here and as mentioned in step 4, before brazing to line set. Cloths must remain water-saturated throughout the brazing and cool-down process.

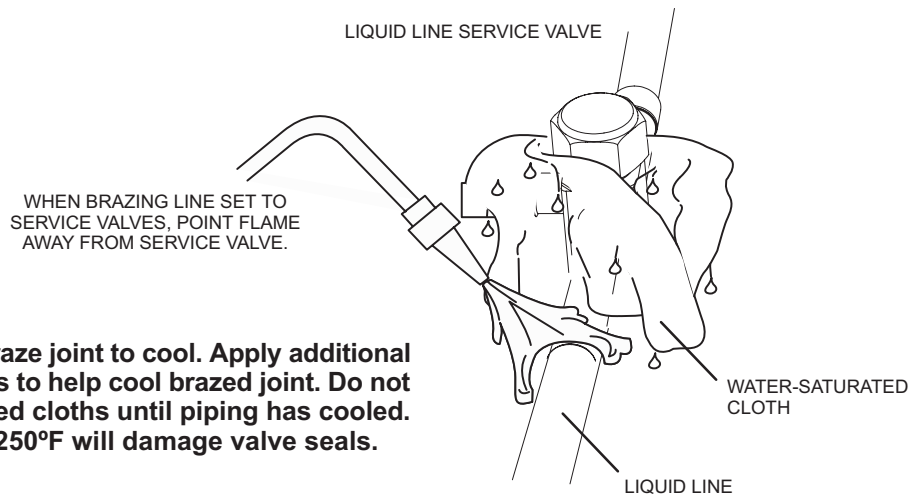

IMPORTANT - Allow braze joint to cool. Apply additional water-saturated cloths to help cool brazed joint. Do not remove water-saturated cloths until piping has cooled. Temperatures above 250°F will damage valve seals.

WARNING

FIRE, PERSONAL INJURY, OR PROPERTY DAMAGE may result if you do not wrap a water-saturated cloth around both liquid and suction line service valve bodies and copper tube stub while brazing the line set! The braze, when complete, must be quenched with water to absorb any residual heat.

Do not open service valves until refrigerant lines and indoor coil have been leak-tested and evacuated. Refer to Installation and Service Procedures manual found on LennoxPros.com.

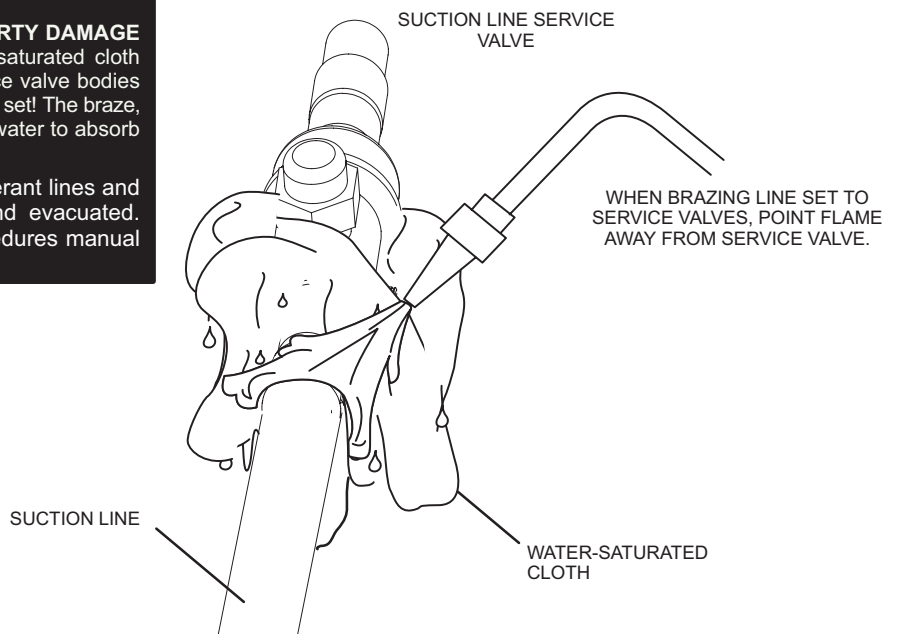

7 PREPARATION FOR NEXT STEP

Disconnect manifold gauge set from service ports after all connections have been brazed. Apply additional water-saturated cloths to both service valves to cool piping. Once piping is cool, remove all water-saturated cloths.

FIGURE 10. Brazing Procedures (Cont'd)

Flushing Line Set and Indoor Coil

1A TYPICAL EXISTING FIXED ORIFICE REMOVAL PROCEDURE (UNCASED OR COIL SHOWN)

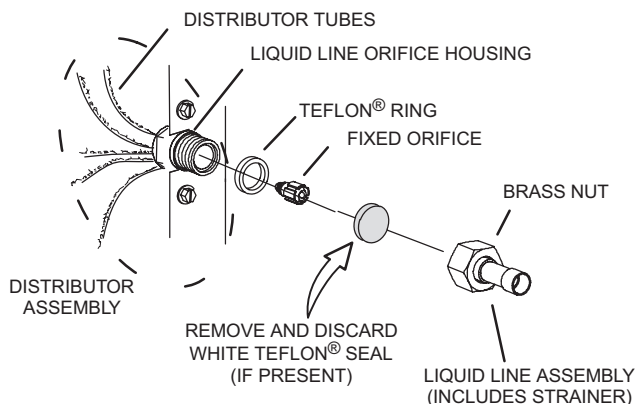

- A On fully cased coils, remove the coil access and plumbing panels.
- B Remove any shipping clamps holding the liquid line and distributor assembly.
- C Using two wrenches, disconnect liquid line from liquid line orifice housing. Take care not to twist or damage distributor tubes during this process.
- D Remove and discard fixed orifice, valve stem assembly if present and Teflon® washer as illustrated above.
- E Use a field-provided fitting to temporarily reconnect the liquid line to the indoor unit's liquid line orifice housing.

1B TYPICAL EXISTING EXPANSION VALVE REMOVAL PROCEDURE (UNCASED COIL SHOWN)

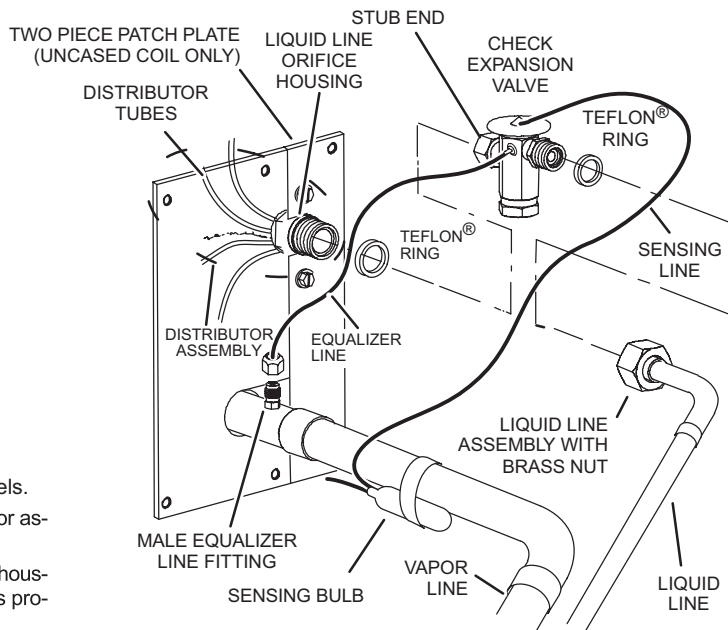

- A On fully cased coils, remove the coil access and plumbing panels.
- B Remove any shipping clamps holding the liquid line and distributor assembly.
- C Disconnect the equalizer line from the check expansion valve equalizer line fitting on the vapor line.
- D Remove the vapor line sensing bulb.
- E Disconnect the liquid line from the check expansion valve at the liquid line assembly.
- F Disconnect the check expansion valve from the liquid line orifice housing. Take care not to twist or damage distributor tubes during this process.
- G Remove and discard check expansion valve and the two Teflon® rings.
- H Use a field-provided fitting to temporarily reconnect the liquid line to the indoor unit's liquid line orifice housing.

2 CONNECT GAUGES AND EQUIPMENT FOR FLUSHING PROCEDURE

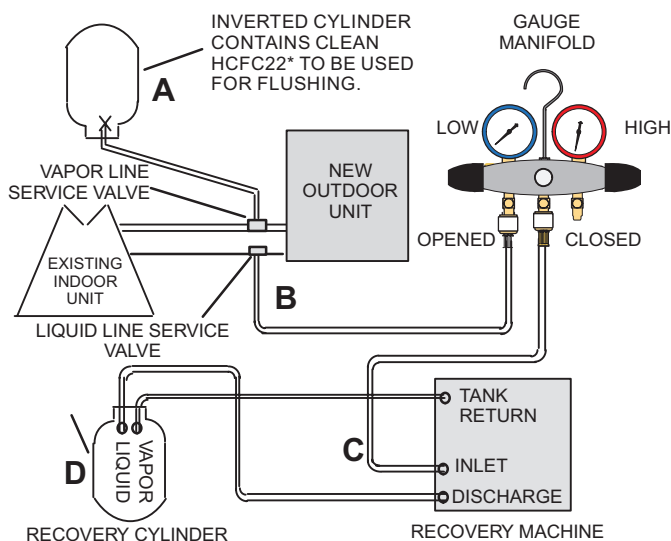

- A Inverted R-454B cylinder with clean refrigerant* to the vapor service valve.
- B R-454B gauge set (low side) to the liquid line valve.
- C R-454B gauge set center port to inlet on the recovery machine with an empty recovery tank to the gauge set.
- D Connect recovery tank to recovery machines per machine instructions.

***IMPORTANT - Clean refrigerant is any refrigerant in a system that has not had compressor burn out. If the system has experienced burn out, it is recommended that the existing line set and indoor coil be replaced.**

3 FLUSHING LINE SET

The line set and indoor unit coil must be flushed with at least the same amount of clean refrigerant* that previously charged the system. Check the charge in the flushing cylinder before proceeding.

- A Set the recovery machine for liquid recovery and start the recovery machine. Open the gauge set valves to allow the recovery machine to pull a vacuum on the existing system line set and indoor unit coil.
- B Invert the cylinder of clean R-454B* and open its valve to allow liquid refrigerant to flow into the system through the vapor line valve. Allow the refrigerant to pass from the cylinder and through the line set and the indoor unit coil before it enters the recovery machine.
- C After all of the liquid refrigerant has been recovered, switch the recovery machine to vapor recovery so that all of the R-454B vapor is recovered. Allow the recovery machine to pull the system down to 0.
- D Close the valve on the inverted R-454B drum and the gauge set valves. Pump the remaining refrigerant out of the recovery machine and turn the machine off.

FIGURE 11. Removing Metering Device and Flushing

FLUSHING LINE SET AND INDOOR COIL (2 OF 2)

4 TYPICAL NEW CHECK EXPANSION VALVE INSTALLATION PROCEDURE

THIS OUTDOOR UNIT IS DESIGNED FOR USE IN SYSTEMS THAT USE A CHECK EXPANSION VALVE METERING DEVICE. SEE THE UNIT PRODUCT SPECIFICATIONS FOR APPROVED EXPANSION VALVE KIT MATCH-UPS AND APPLICATION INFORMATION.

THE EXPANSION VALVE UNIT CAN BE INSTALLED INTERNAL OR EXTERNAL TO THE INDOOR COIL. IN APPLICATIONS WHERE AN UNCASSED COIL IS BEING INSTALLED IN A FIELD-PROVIDED PLENUM, INSTALL THE CHECK EXPANSION VALVE IN A MANNER THAT WILL PROVIDE ACCESS FOR FIELD SERVICING OF THE EXPANSION VALVE. REFER TO BELOW ILLUSTRATION FOR REFERENCE DURING INSTALLATION OF EXPANSION VALVE UNIT.

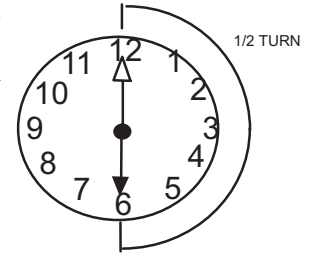
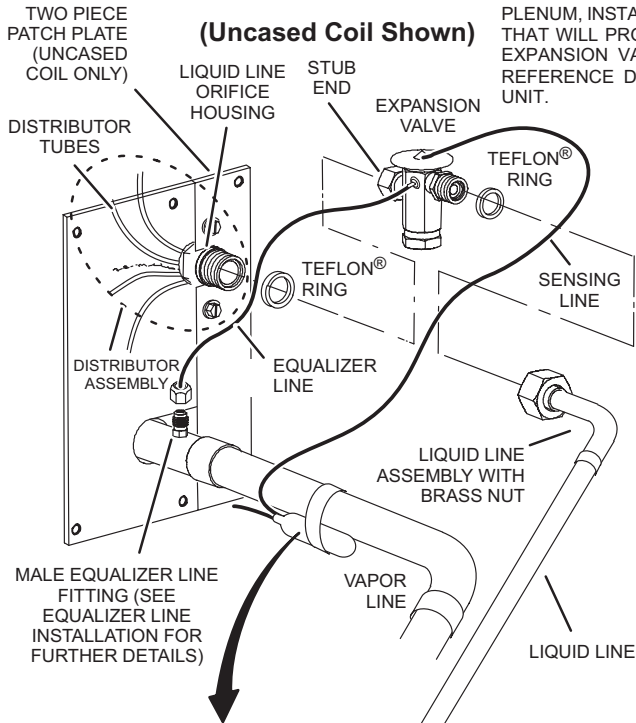

- REMOVE THE FIELD-PROVIDED FITTING THAT TEMPORARILY RECONNECTED THE LIQUID LINE TO THE INDOOR UNIT'S DISTRIBUTOR ASSEMBLY.
- INSTALL ONE OF THE PROVIDED TEFLON® RINGS AROUND THE STUBBED END OF THE EXPANSION VALVE AND LIGHTLY LUBRICATE THE CONNECTOR THREADS AND EXPOSE SURFACE OF THE TEFLON® RING WITH REFRIGERANT OIL.
- ATTACH THE STUBBED END OF THE EXPANSION VALVE TO THE LIQUID LINE ORIFICE HOUSING. FINGER TIGHTEN AND USE AN APPROPRIATELY SIZED WRENCH TO TURN AN ADDITIONAL 1/2 TURN CLOCKWISE AS ILLUSTRATED IN THE FIGURE ABOVE, OR 20 FT-LB.
- PLACE THE REMAINING TEFLON® WASHER AROUND THE OTHER END OF THE EXPANSION VALVE. LIGHTLY LUBRICATE CONNECTOR THREADS AND EXPOSE SURFACE OF THE TEFLON® RING WITH REFRIGERANT OIL.
- ATTACH THE LIQUID LINE ASSEMBLY TO THE EXPANSION VALVE. FINGER TIGHTEN AND USE AN APPROPRIATELY SIZED WRENCH TO TURN AN ADDITIONAL 1/2 TURN CLOCKWISE AS ILLUSTRATED IN THE FIGURE ABOVE OR 20 FT-LB.

SENSING BULB INSULATION IS REQUIRED IF MOUNTED EXTERNAL TO THE COIL CASING. SEE SENSING BULB INSTALLATION FOR BULB POSITIONING.

SENSING BULB INSTALLATION

- ATTACH THE VAPOR LINE SENSING BULB IN THE PROPER ORIENTATION AS ILLUSTRATED TO THE RIGHT USING THE CLAMP AND SCREWS PROVIDED.

NOTE - CONFIRM PROPER THERMAL CONTACT BETWEEN VAPOR LINE AND CHECK EXPANSION BULB BEFORE INSULATING THE SENSING BULB ONCE INSTALLED.

- CONNECT THE EQUALIZER LINE FROM THE EXPANSION VALVE TO THE EQUALIZER VAPOR PORT ON THE VAPOR LINE. FINGER TIGHTEN THE FLARE NUT PLUS 1/8 TURN (7 FT-LBS) AS ILLUSTRATED BELOW.

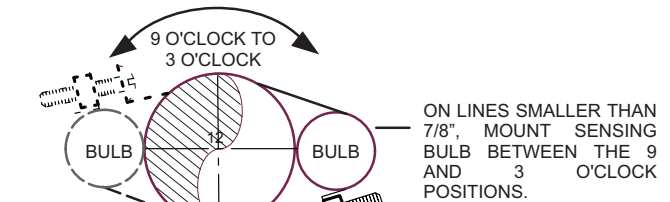
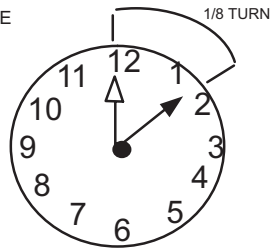

ON LINES SMALLER THAN 7/8", MOUNT SENSING BULB BETWEEN THE 9 AND 3 O'CLOCK POSITIONS.

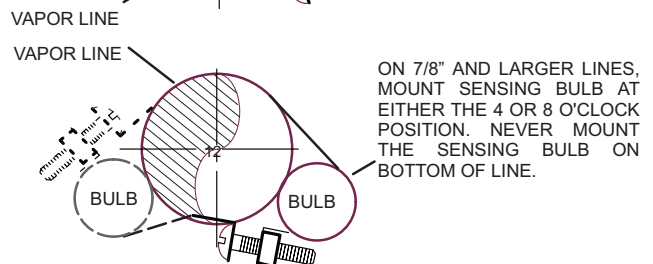

ON 7/8" AND LARGER LINES, MOUNT SENSING BULB AT EITHER THE 4 OR 8 O'CLOCK POSITION. NEVER MOUNT THE SENSING BULB ON BOTTOM OF LINE.

NOTE - NEVER MOUNT THE SENSING BULB ON BOTTOM OF LINE.

EQUALIZER LINE INSTALLATION

REMOVE AND DISCARD EITHER THE FLARE SEAL CAP OR FLARE NUT WITH COPPER FLARE SEAL BONNET FROM THE EQUALIZER LINE PORT ON THE VAPOR LINE AS ILLUSTRATED IN THE FIGURE TO THE RIGHT.

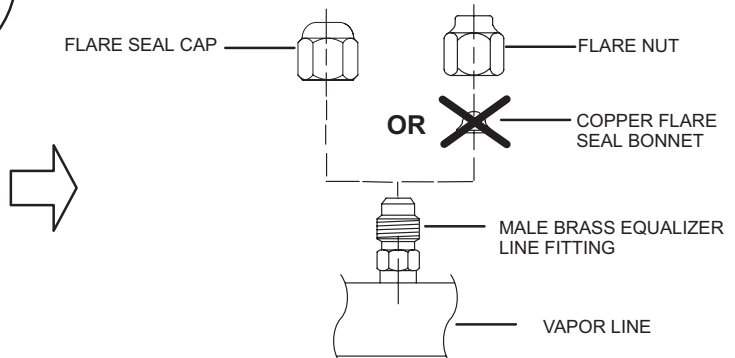

⚠ IMPORTANT

The Environmental Protection Agency (EPA) prohibits the intentional venting of HFC refrigerants during maintenance, service, repair and disposal of appliance. Approved methods of recovery, recycling or reclaiming must be followed.

Leak Testing the System

⚠ WARNING



When using a high pressure gas such as nitrogen to pressurize a refrigeration or air conditioning system, use a regulator that can control the pressure down to 1 or 2 psig (6.9 to 13.8 kPa).

⚠ IMPORTANT

Leak detector must be capable of sensing HFC refrigerant.

⚠ WARNING

Refrigerant can be harmful if it is inhaled. Refrigerant must be used and recovered responsibly.

Failure to follow this warning may result in personal injury or death.

LEAK TEST

LINE SET AND INDOOR COIL

NOTE - NORMALLY, THE HIGH PRESSURE HOSE IS CONNECTED TO THE LIQUID LINE PORT. HOWEVER, CONNECTING IT TO THE VAPOR PORT BETTER PROTECTS THE MANIFOLD GAUGE SET FROM HIGH PRESSURE DAMAGE.

1 CONNECT GAUGE SET

- CONNECT AN R454B MANIFOLD GAUGE SET HIGH PRESSURE HOSE TO THE VAPOR VALVE SERVICE PORT.
- WITH BOTH MANIFOLD VALVES CLOSED, CONNECT THE CYLINDER OF R454B REFRIGERANT TO THE CENTER PORT OF THE MANIFOLD GAUGE SET.

NOTE - LATER IN THE PROCEDURE, THE R454B CONTAINER WILL BE REPLACED BY THE NITROGEN CONTAINER.

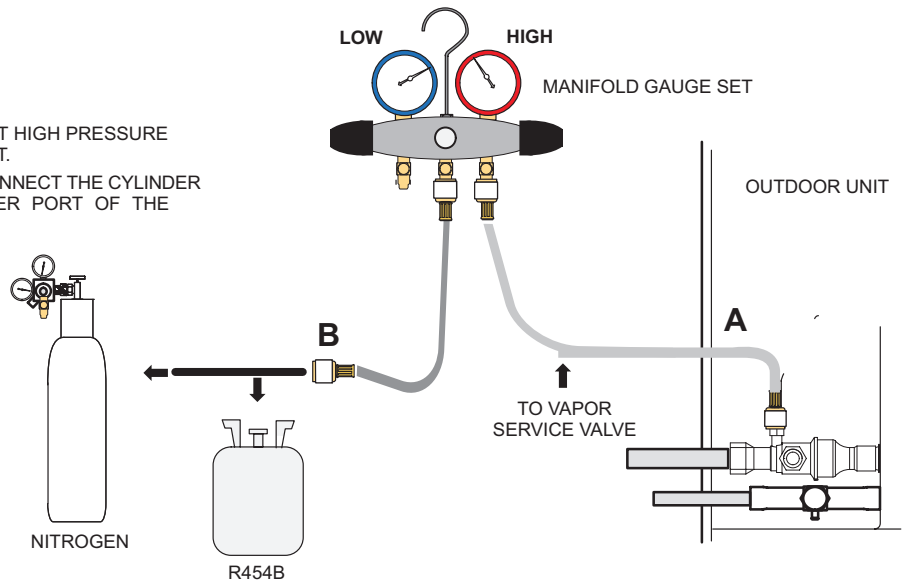

2 TEST FOR LEAKS

AFTER THE LINE SET HAS BEEN CONNECTED TO THE INDOOR AND OUTDOOR UNITS, CHECK THE LINE SET CONNECTIONS AND INDOOR UNIT FOR LEAKS. USE THE FOLLOWING PROCEDURE TO TEST FOR LEAKS:

- WITH BOTH MANIFOLD VALVES CLOSED, CONNECT THE CYLINDER OF R454B REFRIGERANT TO THE CENTER PORT OF THE MANIFOLD GAUGE SET. OPEN THE VALVE ON THE R454B CYLINDER (VAPOR ONLY).
- OPEN THE HIGH PRESSURE SIDE OF THE MANIFOLD TO ALLOW R454B INTO THE LINE SET AND INDOOR UNIT. WEIGH IN A TRACE AMOUNT OF R454B [A TRACE AMOUNT IS A MAXIMUM OF TWO OUNCES (57 G) REFRIGERANT OR THREE POUNDS (31 KPA) PRESSURE]. CLOSE THE VALVE ON THE R454B CYLINDER AND THE VALVE ON THE HIGH PRESSURE SIDE OF THE MANIFOLD GAUGE SET. DISCONNECT THE R454B CYLINDER.
- CONNECT A CYLINDER OF DRY NITROGEN WITH A PRESSURE REGULATING VALVE TO THE CENTER PORT OF THE MANIFOLD GAUGE SET.
- ADJUST DRY NITROGEN PRESSURE TO 150 PSIG (1034 KPA). OPEN THE VALVE ON THE HIGH SIDE OF THE MANIFOLD GAUGE SET IN ORDER TO PRESSURIZE THE LINE SET AND THE INDOOR UNIT.
- AFTER A FEW MINUTES, OPEN ONE OF THE SERVICE VALVE PORTS AND VERIFY THAT THE REFRIGERANT ADDED TO THE SYSTEM EARLIER IS MEASURABLE WITH A LEAK DETECTOR.
- AFTER LEAK TESTING, DISCONNECT GAUGES FROM SERVICE PORTS.

FIGURE 12. System Leak Test

Evacuating Line Set and Indoor Coil

1 CONNECT GAUGE SET

NOTE — Remove cores from service valves (if not already done).

- A** Connect low side of manifold gauge set with 1/4 SAE in-line tee to *vapor* line service valve
- B** Connect high side of manifold gauge set to *liquid* line service valve
- C** Connect micron gauge available connector on the 1/4 SAE in-line tee.
- D** Connect the vacuum pump (with vacuum gauge) to the center port of the manifold gauge set. The center port line will be used later for both the R454B and nitrogen containers.

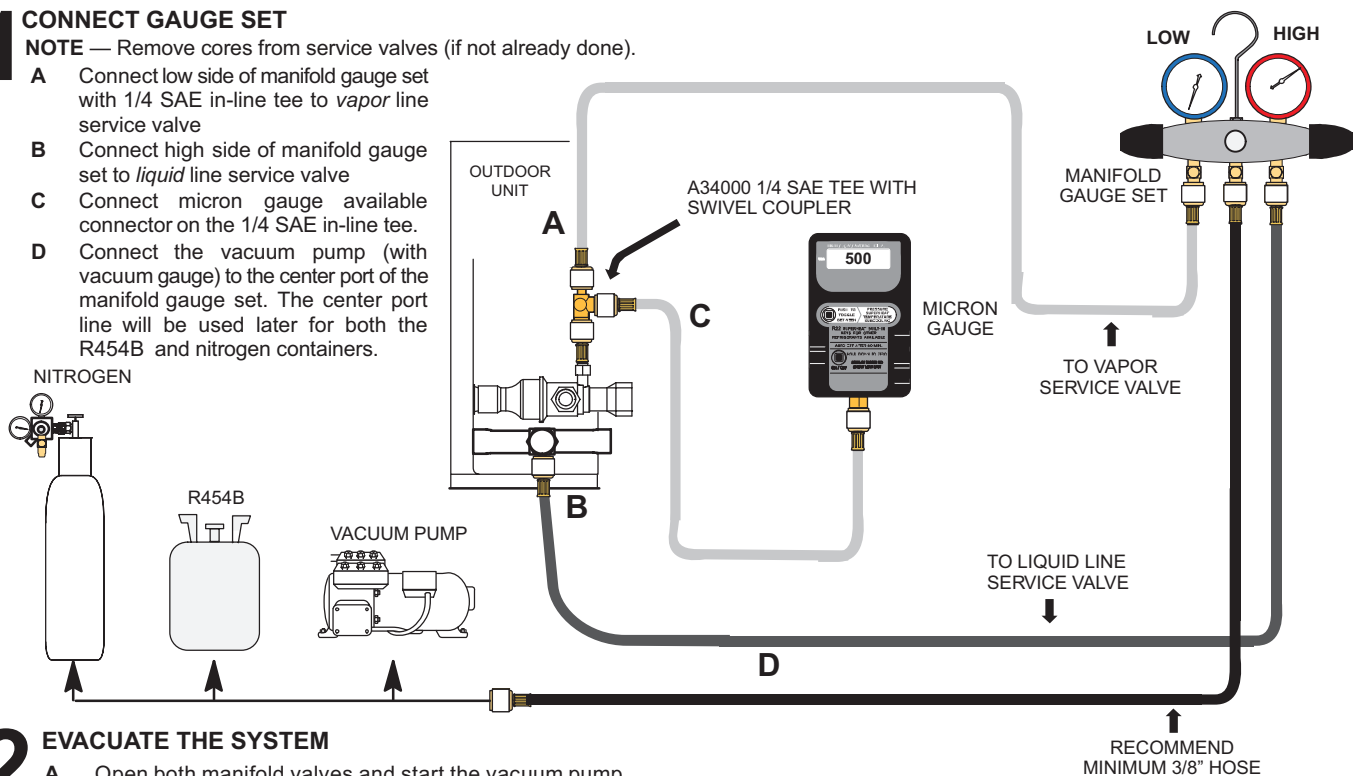

2 EVACUATE THE SYSTEM

- A** Open both manifold valves and start the vacuum pump.
- B** Evacuate the line set and indoor unit to an **absolute pressure** of 23,000 microns (29.01 inches of mercury).
 - NOTE** — During the early stages of evacuation, it is desirable to close the manifold gauge valve at least once. A rapid rise in pressure indicates a relatively large leak. If this occurs, **repeat the leak testing procedure**.
 - NOTE** — The term **absolute pressure** means the total actual pressure within a given volume or system, above the absolute zero of pressure. Absolute pressure in a vacuum is equal to atmospheric pressure minus vacuum pressure.
- C** When the absolute pressure reaches 23,000 microns (29.01 inches of mercury), perform the following:
 - Close manifold gauge valves
 - Close valve on vacuum pump
 - Turn off vacuum pump
 - Disconnect manifold gauge center port hose from vacuum pump
 - Attach manifold center port hose to a dry nitrogen cylinder with pressure regulator set to 150 psig (1034 kPa) and purge the hose.
 - Open manifold gauge valves to break the vacuum in the line set and indoor unit.
 - Close manifold gauge valves.
- D** Shut off the dry nitrogen cylinder and remove the manifold gauge hose from the cylinder. Open the manifold gauge valves to release the dry nitrogen from the line set and indoor unit.
- E** Reconnect the manifold gauge to the vacuum pump, turn the pump on, and continue to evacuate the line set and indoor unit until the absolute pressure does not rise above 500 microns (29.9 inches of mercury) within a 20-minute period after shutting off the vacuum pump and closing the manifold gauge valves.
- F** When the absolute pressure requirement above has been met, disconnect the manifold hose from the vacuum pump and connect it to an upright cylinder of R454B refrigerant. Open the manifold gauge valve 1 to 2 psig in order to release the vacuum in the line set and indoor unit.
- G** Perform the following:
 - Close manifold gauge valves.
 - Shut off R454B cylinder.
 - Reinstall service valve cores by removing manifold hose from service valve. Quickly install cores with core tool while maintaining a positive system pressure.
 - Replace stem caps and secure finger tight, then tighten an additional one-sixth (1/6) of a turn as illustrated.

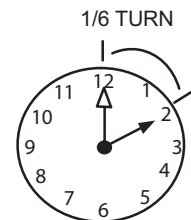

FIGURE 13. Evacuating the System

⚠ IMPORTANT

Use a thermocouple or thermistor electronic vacuum gauge that is calibrated in microns. Use an instrument capable of accurately measuring down to 50 microns.

⚠ WARNING

Possible equipment damage.

Avoid deep vacuum operation. Do not use compressors to evacuate a system. Extremely low vacuum can cause internal arcing and compressor failure. Damage caused by deep vacuum operation will void warranty.

Evacuating the system of non-condensables is critical for proper operation of the unit. Non-condensables are defined as any gas that will not condense under temperatures and pressures present during operation of an air conditioning system. Non-condensables and water suction combine with refrigerant to produce substances that corrode copper piping and compressor parts.

ELECTRICAL – Circuit Sizing and Wire Routing

In the U.S.A., wiring must conform with current local codes and the current National Electric Code (NEC). In Canada, wiring must conform with current local codes and the current Canadian Electrical Code (CEC).

Refer to the furnace or air handler installation instructions for additional wiring application diagrams and refer to unit nameplate for minimum circuit ampacity and maximum overcurrent protection size.

24VAC TRANSFORMER

Use the transformer provided with the furnace or air handler for low-voltage control power (24VAC - 40 VA minimum).

Thermostat Control and Low Voltage Control Wiring

S40 Communicating Thermostat Control

The SL22KLV variable capacity unit must be installed as a fully communicating system consisting of S40 Smart Wi-Fi Thermostat, a communicating indoor unit and the SL22KLV variable capacity outdoor unit wired with (4) communication wires (R, I+, I- and C) connected to the SL22KLV Outdoor Unitary Control.

The SL22KLV variable capacity unit is a fully communicating system that will take full advantage of the advanced diagnostics and control, Wi-Fi accessibility and system operation parameters. The SL22KLV advanced diagnostics include suction pressure, suction temperature, superheat, liquid pressure, liquid temperature and subcooling data which is available in the S40 thermostat diagnostics, remotely on the LennoxPros Service Dashboard and on the Dealer Setup App. Refer to the SL22KLV field wiring diagram for an S40 communicating thermostat.

SL22KLV Low Voltage Control Wiring Connections

The SL22KLV variable capacity units are provided with a RAST 6-Pin connector in the installation instruction bag for connecting the field low voltage control wiring to the SL22KLV field connection harness located in the low voltage make-up box. The RAST connector has 6 terminals: TST, DF, R, I+, I-, C.

⚠ WARNING



Electric Shock Hazard. Can cause injury or death. Unit must be properly grounded in accordance with national and local codes.

Line voltage is present at all components when unit is not in operation on units with single-pole contactors. Disconnect all remote electric power supplies before opening access panel. Unit may have multiple power supplies.

⚠ WARNING

Fire Hazard. Use of aluminum wire with this product may result in a fire, causing property damage, severe injury or death. Use copper wire only with this product.

⚠ WARNING

Failure to use properly sized wiring and circuit breaker may result in property damage. Size wiring and circuit breaker(s) per Product Specifications bulletin (EHB) and unit rating plate.

SL22KLV and S40 Communicating Thermostat Wiring Summary

Thermostat Type	Indoor Unit Type	Qty. of Wires to SL22KLV	SL22KLV Terminal Strip Connections	Unit Operation
Lennox S40 Communicating Thermostat	Communicating Gas Furnace or Air Handler	4	R, I+, I-, C	Fully Communicating Variable Capacity Operation Based Upon Thermostat Demand

SIZE CIRCUIT AND INSTALL SERVICE DISCONNECT SWITCH

Refer to the unit nameplate for minimum circuit ampacity, and maximum fuse or circuit breaker (HACR per NEC). Install power wiring and properly sized disconnect switch.

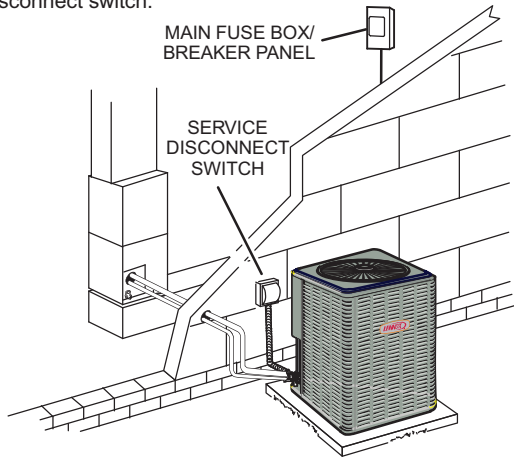

NOTE — Units are approved for use only with copper conductors. Ground unit at disconnect switch or to an earth ground.

INSTALL THERMOSTAT

Install room thermostat (ordered separately) on an inside wall approximately in the center of the conditioned area and 5 feet (1.5m) from the floor. It should not be installed on an outside wall or where it can be affected by sunlight or drafts.

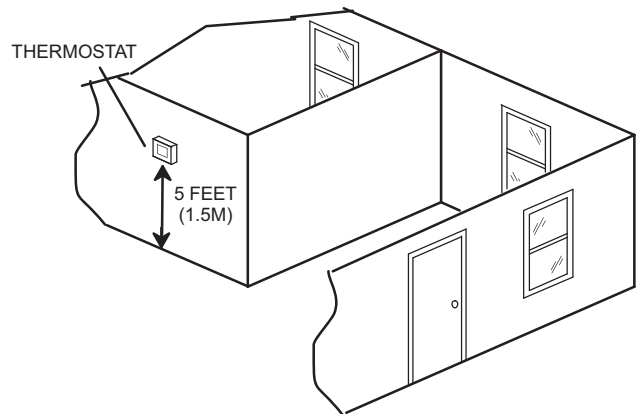

NOTE — 24VAC, Class II circuit connections are made in the control panel.

Outdoor Control (A175) Jumpers and Terminals

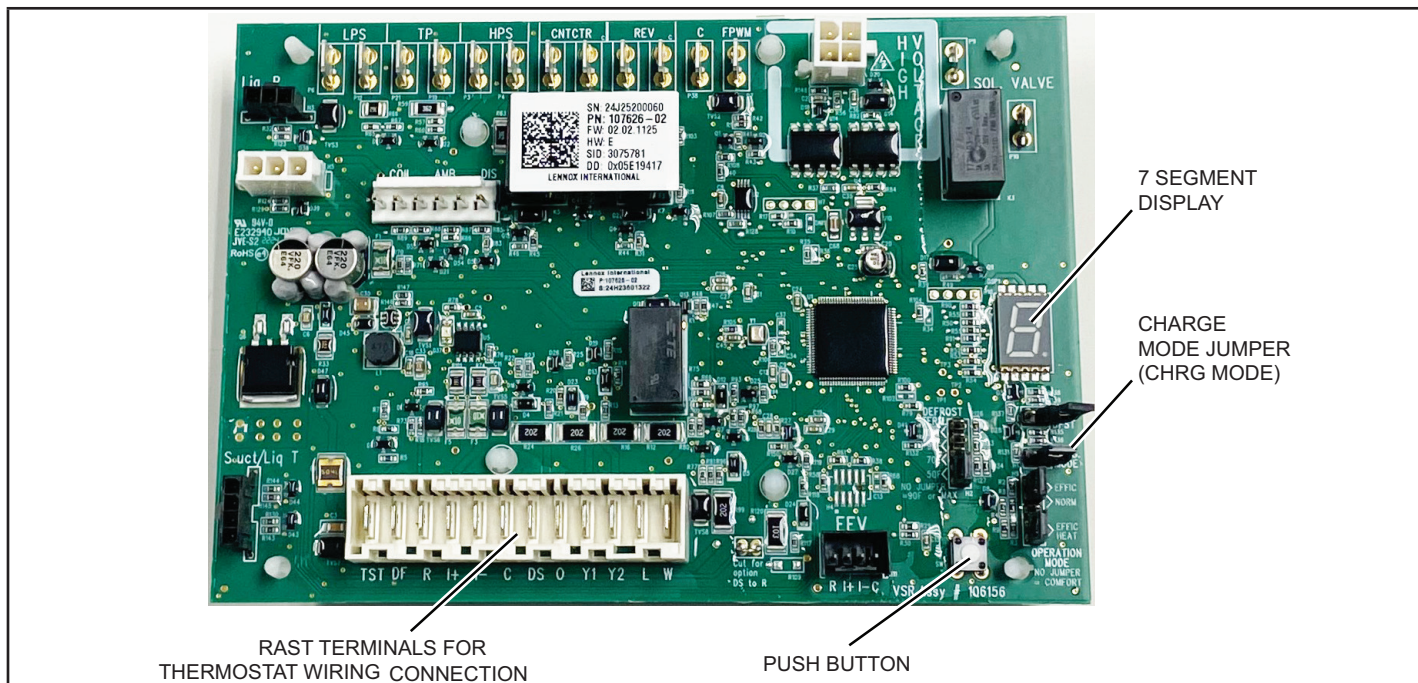

Outdoor Control 7 Segment Display and Push Button

Information concerning the outdoor control 7-segment display and push button operations are available on the unit access panel.

Alarms

Alarm information is provided on the unit access panel.

Unit Operation

SL22KLV Unit Operation with an S40 Communicating Thermostat

The SL22KLV heat pump must be installed with a communicating variable speed handler or furnace and an S40 communicating thermostat. The unit capacity will be controlled in the variable capacity mode throughout the range of capacity from minimum capacity to maximum capacity based upon thermostat demand in both the cooling and heat pump heating mode. The indoor air volume will be controlled to match compressor capacity throughout the capacity range.

Operation Mode Jumper

The SL22KLV is controlled by an S40 communicating thermostat and the Operation Mode jumpers shown are not functional on an SL22KLV system.



TABLE 9

Outdoor Control Terminal Designations and Input /Outputs (see Outdoor Control on pg. 32 for terminal locations)				
Designator	Description	Input	Output	Common
REV	Unused on SL25KCV , for heat pump applications only	N/A	N/A	24VAC common
LPS	Low pressure switch (Not used on SL22KLV)	N/A	N/A	N/A
LPS	Low pressure switch sensing connection (Not used on SL22KLV)	N/A	N/A	N/A
HPS	High pressure switch	N/A	24VAC nominal	N/A
HPS	High pressure switch sensing connection	24VAC nominal	N/A	N/A
TPS	Top cap thermostat switch (in series with the HPS)	N/A	24VAC nominal	N/A
TPS	Top cap thermostat switch sensing connection	24VAC nominal	N/A	N/A
Cntctr	Control (inverter power) contactor switched output (in series with the HPS and TC)	N/A	Switched 24VAC nominal	N/A
Cntctr	Contactor common	N/A		24VAC common
FPWM	PWM fan output	N/A	10-97% duty cycle, 19-23 VDC peak	
C	PWM fan common connection	N/A	N/A	Fan PWM common
P9 SOL. Valve (Liquid Injection Solenoid Valve)	1/4" QC terminals - Switched 24V output for Liquid Injection solenoid valve	N/A	Switched 24VAC Nominal	N/A
RAST Connector Terminal Designations				
W	Not used on SL22KLV Heat Pumps	N/A	N/A	N/A
L	24VAC input to initiate load shed	24VAC nominal from load shed N.O. contacts (close to initiate load shed)	N/A	N/A
Y2	Not used on SL22KLV Heat Pumps	N/A	N/A	N/A
Y1	Used only for "Emergency Mode" when a S40 Communicating Thermostat is not available or for Testing (Drives unit to 100% capacity in Heating or 100% capacity in Cooling when combined with "O" signal.	24VAC nominal	N/A	N/A
O	Used only for "Emergency Mode" when a S40 Communicating Thermostat is not available or for Testing (Drives unit to 100% capacity in Cooling when combined with "Y1" signal.	24VAC nominal	N/A	N/A
DS	Dehumidification input - not used	N/A	N/A	N/A
C	24VAC nominal power return	N/A	N/A	24VAC common
I-	Low data line	Data	Data	N/A
I+	High data line	Data	Data	N/A
R	24VAC nominal power input	24VAC nominal board main power input	N/A	N/A
DF	OEM test	N/A	N/A	N/A
TST	OEM test pin	24VAC nominal	N/A	N/A

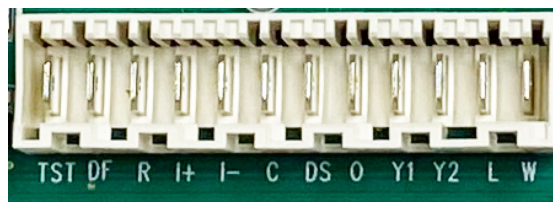
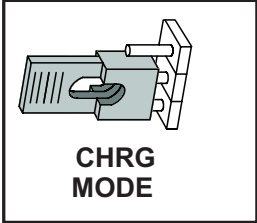
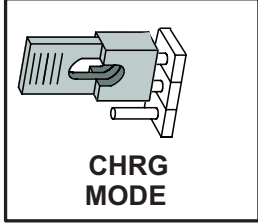

Table 9 continued

Outdoor Control Terminal Designations and Inputs / Outputs					
WARNING - Electric Shock Hazard. Can cause injury or death. Unit must be grounded in accordance with national and local codes. The 4 pins in P6 have the potential of transferring up to 250 volts to the unit cabinet ground.					
Designator		Description	Input	Output	Common
P6 - Pin 1	Tx	Transmit data to inverter, connects to Rx of inverter	Outdoor control communication transmit pin	– Pin 1 to pin 2 should read 4.5 to 5.55 VDC when not communicating – Pin 3 to pin 2 should read 4.5 to 5.55 VDC when not communicating – Pin 4 to pin 2 should read 4.5 to 5.5 VDC NOTE - Communication signals switch off and on rapidly. This may cause volt meter readings to fluctuate. This is normal. Communication signals will switch between this 5V and common (Pin 2).	
P6 - Pin2	Inverter Common	Inverter common NOTE – This is a signal reference point and not an earth ground.	Inverter common		
P6 - Pin 3	Rx	Receive data from the inverter Connects to Tx of inverter	Outdoor control communication receive pin		
P6 - Pin 4	Inv 5V	Inverter 5VDC volts	Inverter 5VDC volts		
	DIS	Discharge Line temperature sensor	N/A	N/A	N/A
	DIS	Discharge Line temperature sensor	N/A	N/A	N/A
	AMB	Outdoor ambient temperature sensor supply	N/A	N/A	N/A
	AMB	Outdoor ambient temperature sensor return	N/A	N/A	N/A
	COIL	Outdoor coil temperature sensor	N/A	N/A	N/A
	COIL	Outdoor coil temperature sensor	N/A	N/A	N/A
	EEV (H11) R	24VAC Communication Buss to EEV Control (not used)	N/A	24VAC	N/A
	EEV (H11) I+	High Data line to EEV Control	Data	Data	N/A
	EEV (H11) I-	Low Data line to EEV Control	Data	Data	N/A
	EEV (H11) C	Common Rs Buss to EEV control	N/A	N/A	24VAC Common

<p style="text-align: center;">CHRG MODE</p>	<p>Charge Mode function. Can be used when charging, checking charge, pump down or checking unit operation. Unit will run at 100% capacity.</p> <p>Conventional thermostat not applicable to SL22KLV.</p> <p>S40 Communicating Thermostat</p> <ol style="list-style-type: none"> 1. Install the Charge Mode jumper 2. Unit will start and run at 100% capacity and communicate to the indoor unit to bring on the blower at 100% of the cooling air volume. 4. Remove the charge mode jumper to end the charge mode <p>NOTE - If the charge mode jumper is in the ON position during power-up, it is ignored.</p> <p>NOTE - If the charge mode is left in place, it will be ignored after 60 minutes.</p>	<div style="display: flex; justify-content: space-around; align-items: center;"> <div style="text-align: center;"> <p>Charge Mode Disabled</p>  <p>CHRG MODE</p> </div> <div style="text-align: center;"> <p>Charge Mode Enabled</p>  <p>CHRG MODE</p> </div> </div>		
Designator	Description	Input	Output	Common
Suction Pressure Out	Pressure transducer Supply Voltage Pin 1 of 3		5 VDC	
Suction Pressure In	Pressure transducer output voltage Pin 2 of 3	0.5-4.5 VDC		
Suction Pressure GND	Pressure transducer GND Pin 3 of 3			VDC Com
Liquid Pressure Out	Pressure transducer Supply Voltage Pin 1 of 3		5 VDC	
Liquid Pressure In	Pressure transducer Supply Voltage Pin 2 of 3	0.5-4.5 VDC		
Liquid Pressure GND	Pressure transducer GND Pin 3 of 3			VDC Com
SUCT1	Suction Line Temperature Sensor Supply - Pin 1 of 4	2.680k ohms to 327.3k ohms		
SUCT2	Suction Line Temperature Sensor Supply - Pin 2 of 4	2.680k ohms to 327.3k ohms		
LIQ1	Liquid Line Temperature Sensor Supply - Pin 3 of 4	2.680k ohms to 327.3k ohms		
LIQ2	Liquid Line Temperature Sensor Supply - Pin 4 of 4	2.680k ohms to 327.3k ohms		

EEV Valve and Controller

The SL22KLV heat pump has an Electronic Expansion Valve (EEV) and check valve assembly in the outdoor unit to control the system refrigerant flow in heat pump heating mode. The EEV precisely controls the refrigerant flow in the heating mode to optimize the unit heating performance. The EEV valve consists of a EEV valve body, EEV valve coil assembly (powerhead), EEV controller, suction pressure transducer, suction temperature sensor, EEV controller 24VAC transformer and check valve.

The EEV controller measures the system superheat by measuring the suction pressure and suction temperature and will precisely control the valve position with up to 550 positions to maintain target superheat of 10°F. The EEV controller will drive the valve to position 200, (36% open position). After a 60 second delay the EEV control will then begin to open or close the EEV valve in small increments to maintain the target superheat of 10°F.

IMPORTANT – Allow EEV to stabilize 15-20 minutes before making charge adjustments based upon subcooling and superheat in the heating mode.

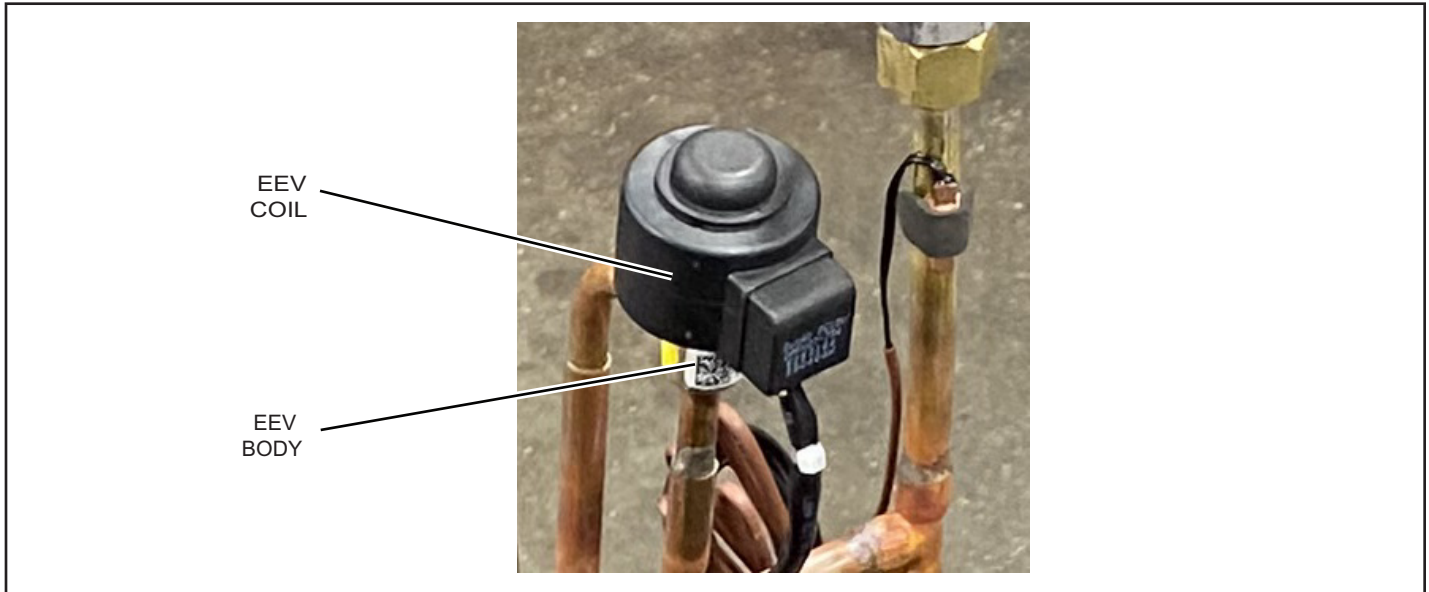

FIGURE 14. EEV Components

Description	Specification
EEV Controller Input Power	24VAC
EEV Valve Coil	12VDC
EEV Valve Coil	Stepper Motor (550 Position)
Valve Initial Operating Position with Compressor Heating Demand	36% 200 Steps
Valve Initial Operating Position Time	60 Seconds
Suction Temperature Sensor	10K ohm NTC
Suction Pressure Transducer Input Voltage	5VDC
Suction Pressure Transducer Output Voltage	0.5 to 4.5VDC
Superheat Setting	10°F
HP EEV Valve Position (Displayed on S40 Thermostat under Diagnostics>Heat Pump)	HP EEV Position displays EEV Valve Position Request in number of Steps (0 is full closed , 550 is full open)

EEV Transformer

The dedicated EEV Transformer located in the SL22KLV control box provides 24 VAC to the EEV controller anytime 230 volt power is applied to the unit.

EEV Controller

The EEV controller is supplied with a continuous 24VAC power by the EEV transformer to terminals R and C.

The EEV Control is controlled by Suction Superheat during the heating mode using the Suction Pressure Transducer connected to the Unitary control. The suction temperature sensor is connected to terminals T1 and GND on the controller. The EEV Controller System Connector provides the 12VDC power to the System EEV Valve coil on terminals A, B, A-, B- and COM in sequence to drive the EEV valve open or close.

The EEV Controller provides a 12VDC signal to the Liquid Injection EEV that is controlled by discharge gas superheat. The Liquid Injection signal is provided on the Injection connector. The Liquid Injection 24V solenoid valve is control by the Sol. Valve terminals on the Unitary Control.

The Discharge Pressure Transducer is connected to the EEV Controller terminals 5V and PS1. The discharge temperature sensor is connected to the Unitary Control DIS Sensor connector.

The SL22KLV Unitary Control communicates to the EEV controller through the RsBus communication harness connected to J7 connector terminals I+, I- & C. The Unitary control has a dedicated RsBus connector labeled EEV on the bottom edge of the control. The Unitary Control and EEV Controller work together to share sensor data, sys-

tem operation and control the System EEV and Liquid Injection EEV during the heating mode. The Unitary Control will provide EEV position, Suction and discharge super heat, diagnostic information and error codes to assist with system diagnostics and operation.

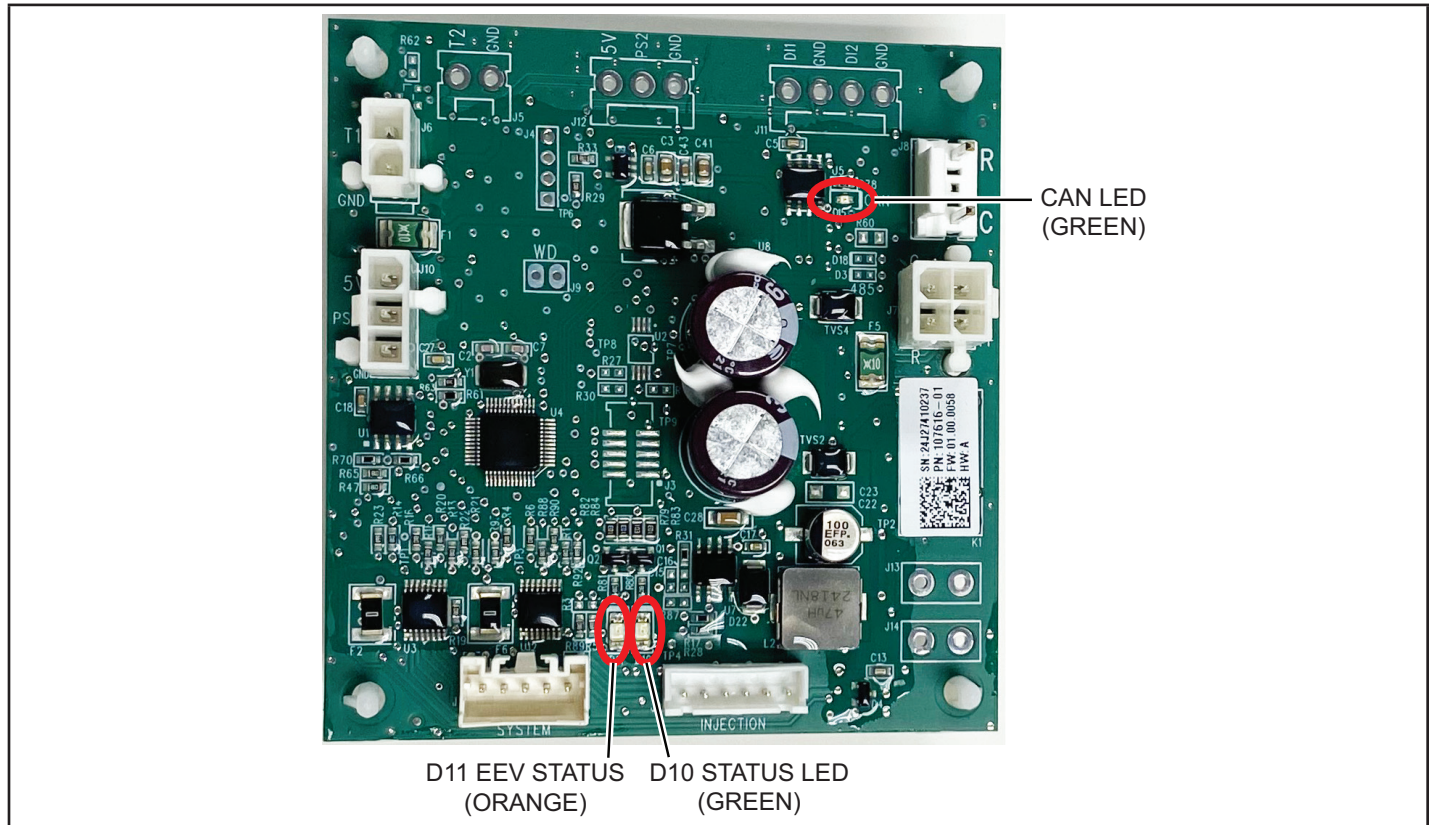

FIGURE 15. EEV Controller Detail

EEV Controller Diagnostics

The EEV controller provides EEV diagnostic information that includes LED Diagnostic LEDs on the EEV Controller, Alarms displayed on the Unitary Control or on the S40 thermostat and diagnostic information related to EEV valve position, EEV winding resistance and system super-heat and additional system information in the S40 thermostat diagnostic information.

NOTE – When operating in the heating mode, allow the system and EEV to stabilize (at least 15 minutes) before making any adjustments.

EEV Controller Diagnostic LED Table

LED	LED Status	Description
CAN LED (Green)	LED Flickers	Indicates RsBus Communication to the Unitary Control
	Off	No RsBus Communication between the EEV Controller and the Unitary Control
D10 Status LED (Green)	1s On, 1s Off	Normal Heartbeat of the EEV Controller Firmware
	Off	No Heartbeat
D11 EEV LED (Orange)	10Hz Blink (10 Blinks per Second)	Indicates EEV is Moving (Open or Closed)
	On	EEV Overcurrent is Reported from the EEV Stepper Motor

S40 EEV Diagnostic Screen

Liquid Line Temp	549 F
Superheat	0.0 F
Suction Line Pressure	149.6 PSI
Suction Line Temp	56.2 F
Discharge Superheat	0.4 F
Discharge Line Pressure	151.0 PSI
Discharge Line Temp	58.8 F
HP EEV position	0
LI EEV position	0
HP EEV winding 1 resistance	42.6 ohm
HP EEV winding 2 resistance	42.2 ohm
HP EEV winding 3 resistance	42.6 ohm
HP EEV winding 4 resistance	42.6 ohm

NOTE – The Modulating Unitary Control / S40 provides any diagnostic information related to the EEV Controller / System EEV Valve and Liquid Injection EEV Valve.

SL22KLV EEV Alarm Codes

Alarm Code	Description
E480	The EEV control board has stopped communicating with the outdoor control. Heat pump heating operation stopped. Check EEV communication cable and EEV control board power.
E481	Discharge pressure transducer fault. Discharge pressures sensor signal is out of range. The signal should be between 0.5 and 4.5 Vdc between Blue and Black. The error code will be cleared when the proper signal is provided to the control. Injection will be disabled, heating and cooling demands will still be serviced.
E482	Compressor Suction Temperature Sensor has malfunctioned. Check temperature sensor resistance in the applicable Installation and Service Procedure Manual. Nominal resistance is 10K ohms at 77°F. Compressor speed limited to 70 hz.
E484	System EEV coil current too low. Heat pump operation can continue. Check system EEV coil connection to the EEV controller
E485	System EEV coil current too high. Heat pump heating operation stopped. Check system EEV coil connection to EEV controller
E486	System superheat below 3 degrees F for more than 10 minutes. Heat pump heating operation stopped.
E487	System superheat higher than 40 degrees F for more than 10 minutes. Heat pump heating operation stopped.

EEV Valve Coil

The valve coil is connected to the EEV body by sliding the coil over the valve body and turning the coil until the tab coil is locked into one of the five mating holes on the valve body. The EEV coil will drive the EEV valve open or closed in small increments up to 550 positions by pulsing the A, B, A- and B- in sequence to create a rotating action of the EEV valve stepper motor.

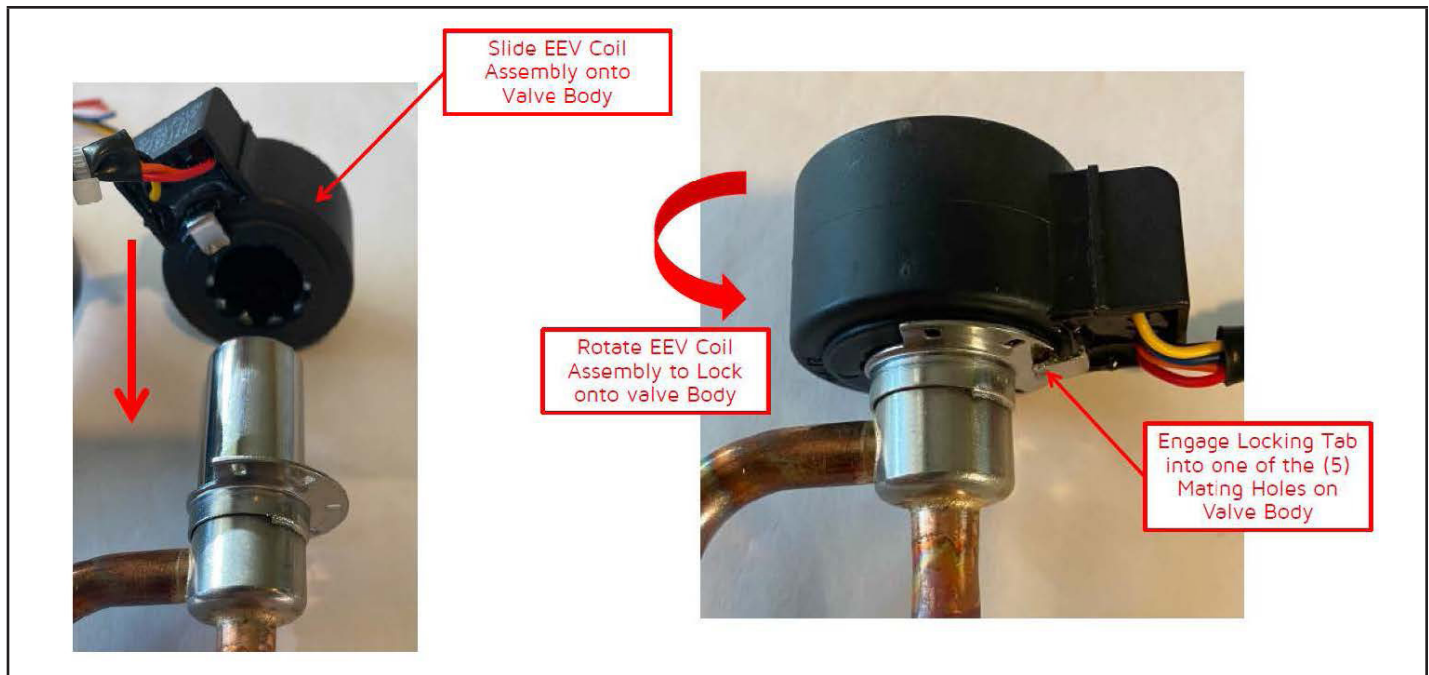

FIGURE 16. EEV Valve Coil Detail

EEV Controller Suction Pressure Transducer

The EEV suction pressure transducer is a 0 to 200 PSIG transducer and is powered with a 5VDC source from the EEV controller. The suction pressure transducer will provide 0 to 4.5VDC signal to the EEV controller based upon the suction pressure.

See the EEV Suction Pressure Transducer Output Voltage Table. The suction pressure transducer output voltage measured with a DC volt meter should match the table below for the corresponding suction pressure measured with a set of manifold gauges.

EEV Suction Pressure Transducer Output Voltage

Suction Pressure (PSIG)	DC Voltage Output (Blue to Black)	Suction Pressure (PSIG)	DC Voltage Output (Blue to Black)
0	0.49	110	2.69
10	0.69	120	2.89
20	0.89	130	3.09
30	1.09	140	3.29
40	1.29	150	3.49
50	1.49	160	3.69
60	1.69	170	3.89
70	1.89	180	4.09
80	2.09	190	4.29
90	2.29	200	4.49
100	2.49	210	4.50

EEV Suction Temperature Sensor

The EEV suction temperature sensor is a nominal 10K ohm NTC thermistor that measures the suction line temperature. See the Suction Temperature Sensor Resistance Table for the sensor resistance at the corresponding suction line temperature.

Compressor Liquid Injection

The SL22KLV cold climate heat pump refrigeration system includes compressor liquid injection. The SL22KLV compressor liquid injection system injects saturation liquid refrigerant directly into the compressor scroll set through a third port on the compressor shell during low ambient heating operation. The compressor liquid injection protects the compressor from excessive discharge temperatures during low ambient heating modes. The compressor liquid injection system consists of a brazed plate heat exchanger, Liquid injection solenoid valve and liquid injection electronic expansion valve.

Brazed Plate Heat Exchanger

The brazed plate heat exchanger increases the subcooling and optimizes the saturated liquid refrigerant properties for liquid injection to lower compressor discharge temperatures and maintain system capacity.

Liquid Injection Solenoid

The Liquid injection solenoid valve has 24VAC coil controlled by the unitary control. The unitary control will open the solenoid valve when unit is operating in the heating mode below 20°F to allow liquid refrigerant from the brazed plate heat exchanger to be injected into the compressor scroll set based upon compressor discharge superheat. The flow of refrigerant is controlled by the Liquid Injection EEV.

Liquid Injection EEV Valve

The liquid injection EEV is controlled by compressor discharge superheat and will control the amount of liquid refrigerant injection into the compressor scroll set to maintain the target discharge superheat. The liquid injection EEV will begin to open when the discharge superheat is above 85°F and modulate to control discharge superheat between 35°F and 85°F.

See the liquid injection piping schematic and liquid injection flow charts below for details on the liquid injection operation.

Liquid Injection Piping Schematic

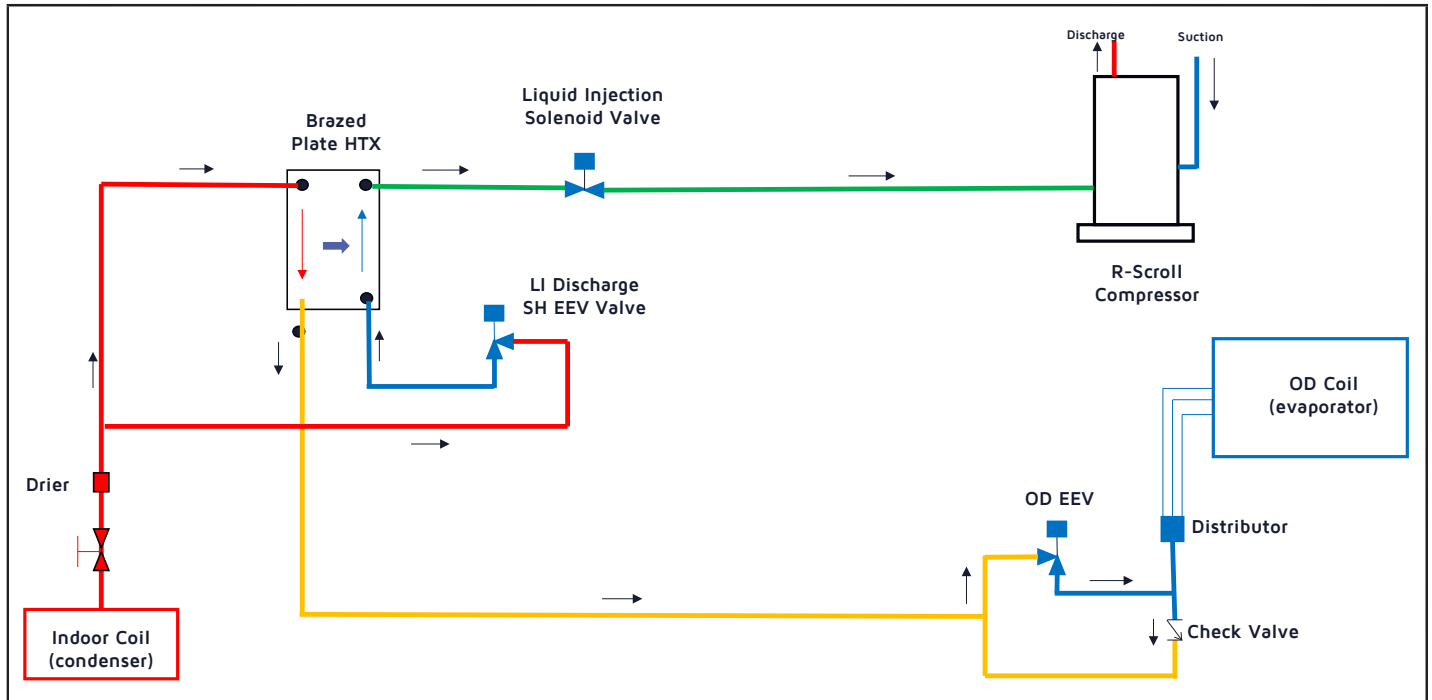

- Brazed plate Heat Exchanger increases subcooling and increases refrigerant.
- The enthalpy difference across the outdoor evaporator coil increases capacity.
- The brazed plate heat exchanger optimizes the saturated liquid properties for liquid injection to maintain compressor speed. It helps maintain system capacity and will lower the compressor discharge temperatures.

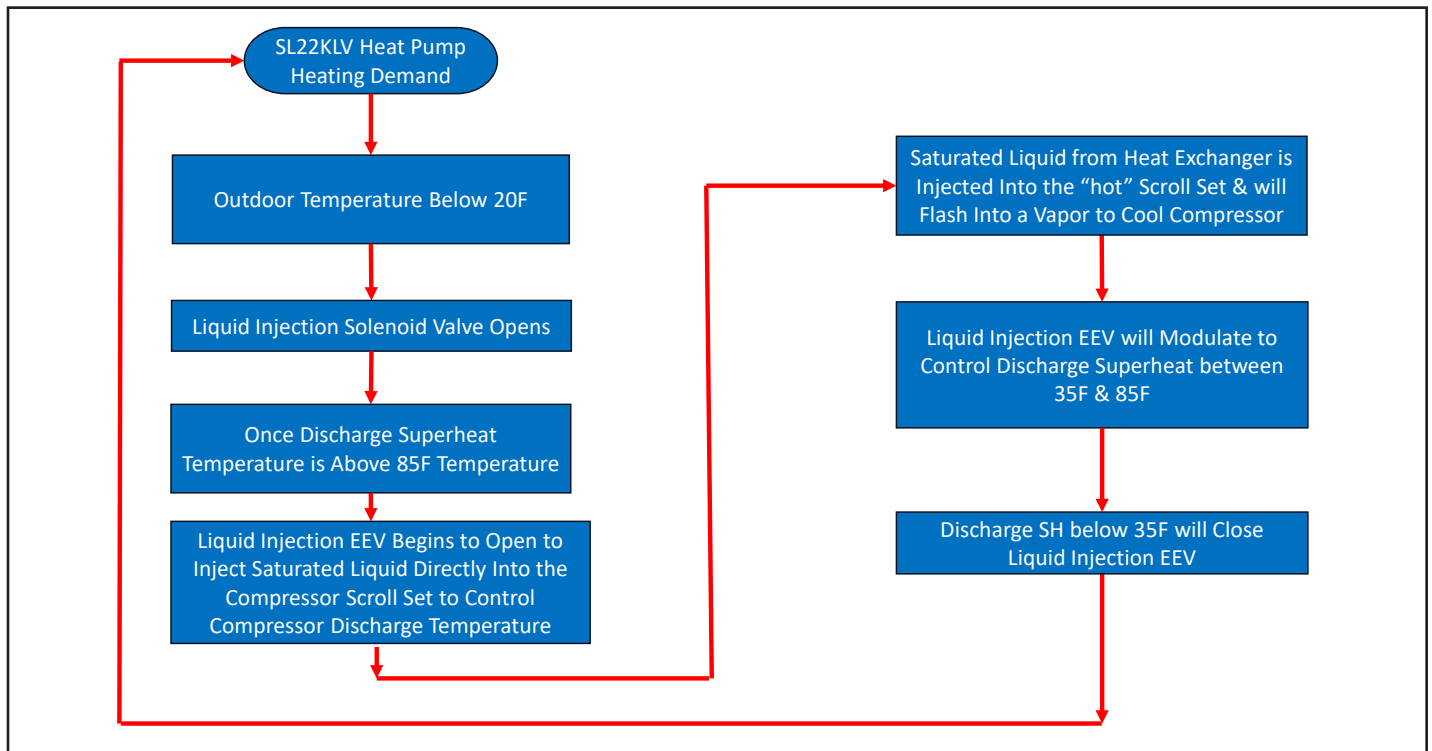

Compressor Liquid Injection Diagnostic Information

The S40 Smart Communicating thermostat provides diagnostic information related to the liquid injection system and compressor discharge superheat that may be viewed at the S40 thermostat under Advanced Settings>Dealer Service Center>Diagnostics>Heat Pump, using the Lennox Smart Tech App or remotely using the LennoxPros Service Dashboard.

Liquid Injection Diagnostic Information Available:

- Discharge Superheat
- Liquid Injection Solenoid Valve State
- Liquid Injection EEV Position
- Liquid Injection EEV Winding Resistance
- Discharge line pressure
- Discharge Line Temperature
- Compressor speed, refrigerant pressures and other diagnostic information

S40 Thermostat Diagnostic Information – Liquid Injection

Diagnostics	
Air Handler	Heat Pump
<input type="checkbox"/>	<input checked="" type="checkbox"/>
Stop	
Comp. Short Cycle Delay Active	No
Cooling Rate	00 %
Heating Rate	00 %
Compressor Shift Delay Active	No
Defrost Status	Off
Reversing Valve Status	Heat Mode
High Pressure Switch	Closed
Low Pressure Switch	Closed
Top Cap Switch Status	Closed
Ambient Temp	47.4 F
Coil Temp	50.9 F
Target Frost Accumulation Time	90 min

Discharge Line Pressure	168.1 PSI
Discharge Line Temp	57.2 F
HP EEV position	0
LI EEV position	0
HP EEV winding 1 resistance	426 ohm
HP EEV winding 2 resistance	422 ohm
HP EEV winding 3 resistance	426 ohm
HP EEV winding 4 resistance	426 ohm
LI EEV winding 1 resistance	426 ohm
LI EEV winding 2 resistance	422 ohm
LI EEV winding 3 resistance	426 ohm
LI EEV winding 4 resistance	426 ohm
Liquid Injection Solenoid State	Off
Compressor Side Suction Temp	52.4 F

Discharge Line Sensor Temperature Resistance Table

°F	Resis. Ohms	°F	Resis. Ohms	°F	Resis. Ohms	°F	Resis. Ohms	°F	Resis. Ohms
0	85,407	51	19378	101	5697	151	2003	201	814
1	82,739	52	18871	102	5570	152	1965	202	800
2	80,163	53	18378	103	5447	153	1927	203	787
3	77,677	54	17900	104	5326	154	1891	204	774
4	75,276	55	17437	105	5209	155	1855	205	761
5	72,957	56	16986	106	5094	156	1820	206	749
6	70,718	57	16549	107	4982	157	1785	207	736
7	68,555	58	16124	108	4873	158	1752	208	724
8	66,466	59	15712	109	4767	159	1719	209	712
9	64,447	60	15311	110	4664	160	1687	210	701
10	62,497	61	14923	111	4563	161	1655	211	690
11	60,613	62	14545	112	4464	162	1624	212	678
12	58,791	63	14178	113	4368	163	1594	213	667
13	57,031	64	13821	114	4274	164	1565	214	657
14	55,329	65	13475	115	4183	165	1536	215	646
15	53,684	66	13138	116	4094	166	1508	216	636
16	52,093	67	12811	117	4007	167	1480	217	626
17	50,555	68	12493	118	3922	168	1453	218	616
18	49,067	69	12183	119	3839	169	1427	219	606
19	47,628	70	11883	120	3758	170	1401	220	597
20	46,236	71	11591	121	3679	171	1376	221	587
21	44,890	72	11307	122	3602	172	1351	222	578
22	43,587	73	11031	123	3527	173	1327	223	569
23	42,327	74	10762	124	3453	174	1303	224	560
24	41,107	75	10501	125	3382	175	1280	225	551
25	39,926	76	10247	126	3312	176	1257	226	543
26	38,783	77	10000	127	3244	177	1234	227	534
27	37,677	78	9760	128	3177	178	1212	228	526
28	36,606	79	9526	129	3112	179	1191	229	518
29	35,569	80	9299	130	3048	180	1170	230	510
30	34,565	81	9077	131	2986	181	1149	231	502
31	33,592	82	8862	132	2925	182	1129	232	495
32	32,650	83	8652	133	2866	183	1109	233	487
33	31,738	84	8448	134	2808	184	1090	234	480
34	30,855	85	8250	135	2752	185	1071	235	473
35	29,999	86	8057	136	2696	186	1052	236	465
36	29,170	87	7869	137	2642	187	1034	237	458
37	28,366	88	7685	138	2590	188	1016	238	452
38	27,588	89	7507	139	2538	189	999	239	445
39	26,833	90	7334	140	2488	190	982	240	438
40	26,101	91	7165	141	2439	191	965	241	432
41	25,392	92	7000	142	2390	192	948	242	425
42	24,705	93	6840	143	2343	193	932	243	419
43	24,038	94	6683	144	2297	194	916	244	413
44	23,392	95	6531	145	2253	195	901	245	407
45	22,765	96	6383	146	2209	196	885	246	401
46	22,156	97	6239	147	2166	197	871	247	395
47	21,567	98	6098	148	2124	198	856	248	389
48	20,994	99	5961	149	2083	199	842	249	384
49	20,439	100	5827	150	2043	200	827	250	378
50	19,901	---	---	---	---	---	---	---	---

EEV Suction Temperature Sensor Resistance

Temp(°F)	Resistance	Temp(°F)	Resistance	Temp(°F)	Resistance
0	87221	52	19005	102	5548
1	82353	54	18120	104	5329
3	77786	55	17280	106	5119
5	73500	57	16485	108	4919
7	69474	59	15730	109	4727
9	65693	61	15015	111	4544
10	62140	63	14336	113	4369
12	58801	64	13692	115	4202
14	55661	66	13080	117	4042
16	52707	68	12499	118	3888
18	49928	70	11947	120	3741
19	47311	72	11423	122	3601
21	44848	73	10924	124	3468
23	42527	75	10451	126	3340
25	40340	77	10000	127	3217
27	38278	79	9556	129	3100
28	36334	81	9153	131	2987
30	34501	82	8769	133	2880
32	32770	84	8402	135	2776
34	31137	86	8053	136	2677
36	29596	88	7719	138	2582
37	28140	90	7402	140	2490
39	26763	91	7099	142	2403
41	25463	93	6809	144	2319
43	24233	95	6533	145	2238
45	23069	97	6270	147	2161
46	21968	99	6018	149	2086
48	20926	100	5778	---	---
50	19940	---	---	---	---

Servicing Units Delivered Void of Charge

If the outdoor unit is void of refrigerant, clean the system using the procedure described below.

- 1 - Leak test the system using the procedure outlined on page 24.
- 2 - Evacuate the system using procedure outlined on page 25.
- 3 - Use nitrogen to break the vacuum and install a new filter drier in the system.
- 4 - Evacuate the system again using procedure outlined on page 25.
- 5 - Weigh in refrigerant using procedure outlined in figure 56.
- 6 - Monitor the system to determine the amount of moisture remaining in the oil. It may be necessary to replace the filter drier several times to achieve the required dryness level. **If system dryness is not verified, the compressor will fail in the future.**

Unit Start-Up

IMPORTANT

If unit is equipped with a crankcase heater, it should be energized 24 hours before unit start-up to prevent compressor damage as a result of slugging.

- 1 - Rotate fan to check for binding.
- 2 - Inspect all factory- and field-installed wiring for loose connections.
- 3 - After evacuation is complete, open both the liquid and vapor line service valves to release the refrigerant charge contained in outdoor unit into the system.
- 4 - Replace the stem caps and tighten to the value listed in table 1.
- 5 - Check voltage supply at the disconnect switch. The voltage must be within the range listed on the unit's nameplate. If not, do not start the equipment until you have consulted with the power company and the voltage condition has been corrected.
- 6 - Set the thermostat for a cooling demand. Turn on power to the indoor unit and close the outdoor unit disconnect switch to start the unit.
- 7 - Recheck voltage while the unit is running. Power must be within range shown on the nameplate.
- 8 - Check system for sufficient refrigerant by using the procedures listed in the System Refrigerant section on page 84.

System Operation and Service

7-SEGMENT ALERT AND SYSTEM STATUS CODES

Alert codes are displayed using the 7-segment display located on the outdoor control.

NOTE - System fault and lockout codes take precedence over system status codes (cooling, heating operating percentages or defrost/dehumidification).

The 7-segment will display an abnormal condition (error code) when detected in the system. A list of the codes are shown in table 6.

Resetting Alert Codes

Alert codes can be reset manually or automatically:

1 - Manual Reset

Manual reset can be achieved by one of the following methods:

- Disconnecting R wire from the outdoor control R terminal.
- Turning the indoor unit off and back on again

After power up, all currently displayed codes are cleared.

2 - Automatic Reset

After an alert is detected, the outdoor control continues to monitor the unit's system and compressor operations. When/if conditions return to normal, the alert code is turned off automatically.

NOTE - Error codes can be recalled by following information shown in tables 6 and 7.

TABLE 10. Outdoor Control 7-Segment Display Alert Codes and Inverter LED Flash Codes

NOTE – System fault and lockout codes take precedence over system status codes (cooling, heating operating percentages or defrost / dehumidification). Only the latest active fault or lockout codes are displayed (if present). If no fault or lockout codes are active, then system status codes are displayed. Alert codes are also displayed on the S40 thermostat.

Alert Codes	Inverter Code	Inverter LED Flash Code (number of flashes)		Priority	Alarm Description	Possible Causes and Clearing Alarm
		Red LED	Green LED			
N/A	N/A	ON	OFF	N/A	SL22KLV-024 only: Indicates inverter is operating normally.	
N/A	N/A	ON	ON	N/A	SL22KLV-036, -048, -060 only: Indicates inverter is operating normally.	
N/A	N/A	OFF	OFF	N/A	Indicates inverter is NOT energized.	
E105	N/A	N/A	N/A	Service Soon	The outdoor control has lost communication with either the thermostat or indoor unit.	Equipment is unable to communicate. Indicates numerous message errors. In most cases errors are related to electrical noise. Make sure high voltage power is separated from RSBus. Check for miswired and/or loose connections between the stat, indoor unit and outdoor unit. Check for a high voltage source of noise close to the system. Fault clears after communication is restored.
E120	N/A	N/A	N/A	Service Soon	There is a delay in the outdoor unit responding to the system.	Typically, this alarm/code does not cause any issues and clears on its own. The alarm/code is usually caused by a delay in the outdoor unit responding to the thermostat. Check all wiring connections. Cleared after unresponsive device responds to any inquiry.
E124	N/A	N/A	N/A	Service Urgent	The S40 thermostat has lost communication with the outdoor unit for more than 3 minutes.	Equipment lost communication with the thermostat. Check the wiring connections and resistance, then cycle the system power. This alarm stops all associated HVAC operations and waits for a signal from the non-communicating unit. The alarm / fault clears after communication is re-established.
E125	N/A	N/A	N/A	Service Urgent	There is a hardware problem with the outdoor control.	There is a control hardware problem. Replace the outdoor control if the problem prevents operation and is persistent. The alarm / fault is cleared 300 seconds after the fault recovers.
E131	N/A	N/A	N/A	Service Urgent	The outdoor unit control parameters are corrupted.	Reconfigure the system. Replace the control if heating or cooling is not available.
E132	N/A	N/A	N/A	Service Urgent	Internal software error.	Replace outdoor control.
E180	N/A	N/A	N/A	Service Soon	The outdoor unit ambient temperature sensor has malfunctioned. As a result the outdoor unit control will not perform low ambient cooling.	Valid temperature reading is lost during normal operation and after outdoor control recognized sensors. Compare outdoor sensor resistance to temperature/ resistance charts in unit installation instructions. Replace sensor pack if necessary. At the beginning of (any) configuration, furnace or airhandler control detects the presence of the sensor(s). If detected (reading in range), appropriate feature is shown in the iComfort S40 thermostat About screen. The alarm / fault clears upon configuration, or when normal values are sensed.
E181	N/A	N/A	N/A	Service Soon	Suction pressure transducer fault.	Suction pressure transducer is out of range. The signal should be between 0.5 VDC and 4.5 VDC between blue and black. The error code will be cleared when proper signal is provided. System controlled by a conventional 24VAC heat pump thermostat will operate in the staged mode.
E182	N/A	N/A	N/A	Service Soon	Suction temperature sensor has malfunctioned.	Check temperature sensor in the applicable installation and service procedure. Nominal resistance is 10K Ohms at 77F.
E183	N/A	N/A	N/A	Service Soon	Liquid Pressure Transducer Fault	Liquid pressure transducer is out of range. The signal should be between 0.5 VDC and 4.5 VDC between Blue and Black. The error code will be cleared when the proper signal is provided. Systems controlled by a conventional 24VAC heat pump thermostat will operate in stage mode.

TABLE 10. Outdoor Control 7-Segment Display Alert Codes and Inverter LED Flash Codes

NOTE – System fault and lockout codes take precedence over system status codes (cooling, heating operating percentages or defrost / dehumidification). Only the latest active fault or lockout codes are displayed (if present). If no fault or lockout codes are active, then system status codes are displayed. Alert codes are also displayed on the S40 thermostat.

Alert Codes	Inverter Code	Inverter LED Flash Code (number of flashes)		Priority	Alarm Description	Possible Causes and Clearing Alarm
		Red LED	Green LED			
E345	N/A	N/A	N/A	Service Urgent	Heat Pump or Air Conditioner Alert Code - The "O" relay on the outdoor board has failed.	Either the pilot relay contacts did not close, the relay coil did not energize the circuit that confirms this operational sequence is not sensing properly.
E409	N/A	N/A	N/A	Service Soon	Outdoor control secondary voltage is 18VAC or less.	Secondary voltage is below 18VAC. After 10 minutes, operation is discontinued. Check the indoor line voltage and transformer output voltage. The alarm clears after the voltage is higher than 20VAC for 2 seconds or after a power reset.
E410	N/A	N/A	N/A	Service Soon	The outdoor unit cycled off due to low suction pressure.	Unit pressure is below the lower limit. The system is shut down. The cut-out is set at 35 PSIG and the cut-in set at 80 PSIG. SL22KLV does not have a Low Pressure switch, the low pressure switch is emulated by the suction pressure transducer. Confirm that the system is properly charged with refrigerant. Check TXV, indoor unit blower motor, dirty filters or clogged refrigerant filter. Confirm that the evaporator coil is clean. Confirm the suction pressure transducer is providing the correct suction pressure reading compared to manifold gauge pressure, if not check pressure transducer connections. The alarm clears after the pressure rises above 80 PSIG.
E411	N/A	N/A	N/A	Service Urgent	The low pressure fault has occurred 5 times within one hour. As a result, the outdoor unit is locked out.	Low pressure fault error count reached 5 strikes. The low pressure cut-out is at 25PSIG and resets at 40PSIG. Confirm that the system is properly charged with refrigerant. Check for clogged TXV, blockage to indoor unit blower motor, dirty filters or clogged refrigerant filter. Confirm that the evaporator coil is clean. Confirm the suction pressure transducer is providing the correct suction pressure reading compared to manifold gauge pressure, if not check pressure transducer connections. The alarm clears after a power reset.
E412	N/A	N/A	N/A	Service Soon	The outdoor unit high pressure switch has opened.	Unit pressure is above the upper limit. System is shut down. The high pressure switch opens at 590PSIG and closes at 418PSIG. Confirm that the system is properly charged with refrigerant. Check for clogged TXV, blockage to indoor unit blower motor, clogged refrigerant filter. Confirm that the outdoor unit is clean. The alarm clears after the pressure switch closes or a power reset. For heating, indoor CFM may be set too low. For zoning system, zone CFM may be set too low.
E413	N/A	N/A	N/A	Service Urgent	The high pressure switch has opened 5 times within one hour. As a result, the outdoor unit is locked out.	Open high pressure switch error count reached 5 strikes. System is shut down. The high pressure switch for HFC410A opens at 590PSIG and closes at 418PSIG. Confirm that the system is properly charged with refrigerant. Check condenser fan motor, for clogged TXV, for blockage to indoor unit blower motor, for stuck reversing valve or clogged refrigerant filter. Confirm that the outdoor unit is clean. The alarm clears after a power reset. For heating, indoor CFM may be set too low. For zoning system, zone CFM may be set too low.
E416	N/A	N/A	N/A	Service Soon/ Service Critical	The outdoor coil sensor has malfunctioned.	SL22KLV has a fixed 10K ohm resistor installed on the harness connector between pins 5 & 6. Check connections on pins 5 & 6 and check for resistance of 10K Ohms. Error code will occur on open or shorted circuit
E422	N/A	N/A	N/A	Service Soon	Compressor top cap switch exceeding thermal limit.	The top of the compressor is hot. Refrigerant charge may be low, or low mass flow of refrigerant. Check TXV, clogged filter drier, condenser fan motor, indoor blower motor, confirm indoor coil is clean.
E423	40	4 flashes	OFF	Service Soon/ Service Critical	The inverter has detected a circuit problem.	Control locks out after 10 strikes within an hour. To clear, disconnect power to the indoor unit (24VAC power source to the outdoor control) which will power off the outdoor control and will open the outdoor unit contactor, which interrupts power to the inverter and then re-apply power.
E424	N/A	N/A	N/A	Service Soon	The liquid line temperature sensor has malfunctioned.	Check connections between pin 3 and 4 of the four pin liquid/suction temperature plug on the bottom left corner of the control. Check resistance of resistor. Nominal 10K Ohms at 77F. Error code occurs if sensor is open or shorted.
E425	N/A	N/A	N/A	Dealer Info Only	Outdoor control has increased minimum compressor speed to allow for proper oil return due to low ambient temperature. NOTE - Minimum speed adjustments begin at 45°F and increase to 100% minimum at 17°F.	Outdoor ambient temperature is below system limit. Control attempts to run at lowest allowed compressor speed to allow for proper oil return. Automatically clears when outdoor ambient temperature rises above limit for more than 5 minutes.

TABLE 10. Outdoor Control 7-Segment Display Alert Codes and Inverter LED Flash Codes

NOTE – System fault and lockout codes take precedence over system status codes (cooling, heating operating percentages or defrost / dehumidification). Only the latest active fault or lockout codes are displayed (if present). If no fault or lockout codes are active, then system status codes are displayed. Alert codes are also displayed on the S40 thermostat.

Alert Codes	Inverter Code	Inverter LED Flash Code (number of flashes)		Priority	Alarm Description	Possible Causes and Clearing Alarm
		Red LED	Green LED			
E427	21	2 flashes	1 flash	Service Soon/ Service Critical	The inverter has detected a DC peak fault condition. If condition (55A or higher) is detected, outdoor unit compressor and fan stop. Anti-short cycle is initiated. If peak current (55A or higher) occurs 10 times within an hour, system is locked out. Indicates high pressure, condenser fan failure, locked compressor rotor or overcharge. To clear, disconnect power to the indoor unit (24VAC power source to the outdoor control) which will power off the outdoor control and will open the outdoor unit contactor, which interrupts power to the inverter and then re-apply power.	
E428	22	2 flashes	2 flashes	Service Soon/ Service Critical	The inverter has detected a high main input current condition.	If condition is detected, is detected, outdoor unit compressor and fan stop. Antishort cycle is initiated. If condition occurs 5 times within an hour, the Unitary Control will cycle the unit contactor to prevent a system lockout. To clear, disconnect power to the indoor unit (24VAC power source to the outdoor control) which will power off the outdoor control and will open the outdoor unit contactor, which interrupts power to the inverter and then re-apply power.
E429	23	2 flashes	3 flashes	Service Soon/ Service Critical	On a call for compressor operation, if DC link power in inverter does not rise above 180 VDC for 2 and 3 ton models, 250 VDC for 4 and 5 ton models, within 30 seconds, the control will display a moderate code. If condition is detected, outdoor unit will stop (Compressor and fan). Antishort cycles is initiated. If condition occurs 10 times within a 60 minute rolling time period, system will lock out and display a critical code.	Issues: (1) If DC link power in inverter does not rise above 180 VDC for 2- and 3-ton models, 250 VDC for 4- and 5-ton models, within 30 seconds, the outdoor control will display a moderate code. (2) Capacitors on inverter do not properly charge. Corrective Actions: (1) Check for proper main power to outdoor unit and for any loose electrical connections.
E430	26	2 flashes	6 flashes	Service Soon/ Service Critical	Compressor start failure	If condition is detected, outdoor unit compressor and fan stop. Antishort cycle is initiated. If condition occurs 10 times within an hour, system is locked out. Indicates poor connection at compressor harness, improper winding resistance, locked compressor rotor, or flooded compressor. To clear, disconnect power to the indoor unit (24VAC power source to the outdoor control) which will power off the outdoor control and will open the outdoor unit contactor, which interrupts power to the inverter and then re-apply power.
E431	27	2 flashes	7 flashes	Service Soon/ Service Critical	Error occurs when PFC detects an over-current condition of 100A, the control will display a moderate code. If condition is detected, outdoor unit will stop (Compressor and fan). Anti-short cycle is initiated. Inverter is unavailable to communicate with the outdoor control for 3 minutes. If condition occurs 10 times within a 60 minute rolling time period, system will lock out and display a critical code.	Issues: (1) Indicates power interruption, brownout, poor electrical connection or loose inverter input wire. (2) System testing was set up and code was generated when the reversing valve is de-energized coming out of defrost (code appears with or without 30 compressor delay). Corrective Actions: (1) Check for proper main power to outdoor unit and for any loose electrical connections. (2) To clear, disconnect power to the indoor unit (24VAC power source to the outdoor control) which will power off the outdoor control and will open the outdoor unit contactor, which interrupts power to the inverter and then re-apply power.
E432	28	2 flashes	8 flashes	Service Soon/ Service Critical	The inverter has detected a DC link high voltage condition	Error occurs when the DC link capacitor voltage is greater than 480VDC. If condition is detected, outdoor unit compressor and fan stop. Anti-short cycle is initiated. If condition occurs 10 times within an hour, system is locked out. System stops. To clear, disconnect power to the indoor unit (24VAC power source to the outdoor control) which will power off the outdoor control and will open the outdoor unit contactor, which interrupts power to the inverter and then re-apply power.

TABLE 10. Outdoor Control 7-Segment Display Alert Codes and Inverter LED Flash Codes

NOTE – System fault and lockout codes take precedence over system status codes (cooling, heating operating percentages or defrost / dehumidification). Only the latest active fault or lockout codes are displayed (if present). If no fault or lockout codes are active, then system status codes are displayed. Alert codes are also displayed on the S40 thermostat.

Alert Codes	Inverter Code	Inverter LED Flash Code (number of flashes)		Priority	Alarm Description	Possible Causes and Clearing Alarm
		Red LED	Green LED			
E433	29	2 flashes	9 flashes	Service Soon/ Service Critical	The inverter has detected a compressor over-current condition.	Error occurs when compressor peak phase current is greater than 28A. Inverter issues code 14 first and slows down to try to reduce the current. If the current remains high, outdoor unit compressor and fan stop. Anti-short cycle is initiated. If condition occurs five times within an hour, the Unitary Control will cycle the unit contactor to prevent a system lockout. To clear, disconnect power to the indoor unit (24VAC power source to the outdoor control) which will power off the outdoor control and will open the outdoor unit contactor, which interrupts power to the inverter and then re-apply power.
E434	53	5 flashes	3 flashes	Service Soon/ Service Critical	Outdoor control has lost communications with the inverter for greater than 3 minutes. Outdoor unit will stop all compressor demand. Outdoor control will attempt to establish communication multiple times and will automatically clear when the error clears. Unit will lock out after 60 minutes if communication is not established and will display a critical error code.	Issues: (1) Outdoor disconnect is off or outdoor power is off, when indoor power is on (source for 24VAC) (2) Loose electrical power connections (3) interruption of main power to the inverter (4) Generator powers indoor unit, but not the outdoor unit. Corrective Actions: (1) To reset, cycle the indoor power off (source of 24VAC to outdoor unit) and back on. This will de-energize outdoor control and inverter by cycling the contactor. (2) Make sure the disconnect is on (3) check electrical power supply connections (4) Check for proper main 230V power supply
E435	60	6 flashes	OFF	Service Soon/ Service Critical	Inverter internal error	When this error occurs, the outdoor control cycles power to the inverter by opening the contactor for two minutes. Check that the EEPROM is properly seated. After power is cycled to the inverter 3 times, the outdoor unit is locked out. If problem persists, replace the inverter.
E436	62	6 flashes	2 flashes	Service Soon/ Service Critical	Inverter heat sink temperature exceeded limit during compressor operation. Occurs when the heat sink temperature exceeds the inverter limit. Inverter issues code 13 first, then slows down to allow the heat sink to cool. If temperature remains high, outdoor unit stops (compressor and fan). Anti-short cycle is initiated. If condition occurs 5 times within an hour, unit will cycle off if heat sink temperature exceeds 185F, during compressor operation along with a E441 compressor slow down message. To clear, disconnect power to the indoor unit (24VAC power source to the outdoor control) which will power off the outdoor control and will open the outdoor unit contactor, which interrupts power to the inverter and then re-apply power.	Issue: This error may occur if the outdoor fan fails to operate or the inverter heat sink is obstructed with debris. Feedback from supplier tear down of inverter indicates that the screws that hold the inverter to the inverter board were loose causing poor contact between these two components. Corrective Action: Tighten screws that hold the heat sink to the inverter control board. NOTE: Wait five minutes to allow capacitor to discharge before checking screws.
E437	65	6 flashes	5 flashes	Service Soon/ Service Critical	Heat sink temperature sensor fault has occurred (temperature less than 4°F or greater than 264°F after 10 minutes of operation).	Occurs when the temperature sensor detects a temperature less than 0.4°F or greater than 264°F after 10 minutes of operation. If condition is detected, outdoor unit will stop (compressor and fan). Anti-short cycle is initiated. If condition occurs 5 times within an hour, system will lock out. To clear, disconnect power to the indoor unit (24VAC power source to the outdoor control) which will power off the outdoor control and will open the outdoor unit contactor, which interrupts power to the inverter and then re-apply power. If problem persists, replace inverter.

TABLE 10. Outdoor Control 7-Segment Display Alert Codes and Inverter LED Flash Codes

NOTE – System fault and lockout codes take precedence over system status codes (cooling, heating operating percentages or defrost / dehumidification). Only the latest active fault or lockout codes are displayed (if present). If no fault or lockout codes are active, then system status codes are displayed. Alert codes are also displayed on the S40 thermostat.

Alert Codes	Inverter Code	Inverter LED Flash Code (number of flashes)		Priority	Alarm Description	Possible Causes and Clearing Alarm
		Red LED	Green LED			
E438	73	7 flashes	3 flashes	Service Soon/ Service Critical	The inverter has detected a PFC over current condition. This would be caused by a high load condition, high pressure, or outdoor fan failure. Outdoor control will display the code when the inverter has the error. After 3 minutes, the inverter will reset and the compressor will turn on again. If it happens 10 times within a 60 minute rolling time period, the OD control will lock out operation of the outdoor unit and display a critical code.	Issue: Possible issue is system running at high pressures. Check for high pressure trips or other alert codes in room thermostat and outdoor control. To clear, disconnect power to the indoor unit (24VAC power source to the outdoor control) which will power off the outdoor control and will open the outdoor unit contactor, which interrupts power to the inverter and then re-apply power.
E439	12	1 flash	2 flashes	Dealer Info Only	Compressor slowdown due to high input current.	This error code is primarily for informational purposes as the inverter controls the compressor to operate within design parameters. Typically the inverter will make a minor speed reduction of 4 Hz (approximately a 5-6% speed reduction) for a brief period of time and to reduce the input current and will then resume normal operation.
E440	13	1 flash	3 flashes	Dealer Info Only	Heat sink temperature is approaching limit. The compressor speed automatically slows to reduce heat sink temperature. The control sets indoor CFM and outdoor RPM to values according to demand percentage rather than the actual Hz. Alarm is automatically cleared.	This error code is primarily for informational purposes as the inverter controls the compressor speed to operate within design parameters. Typically the inverter will make a minor speed reduction of 4 Hz (approximately a 5-6% speed reduction) for a brief period of time and to reduce the heat sink temperature and will then resume normal operation. This may occur at high outdoor temperatures (above 110°F) for brief periods of time (3 – 4 minutes) and is normal and expected operation of the inverter controlling the compressor safely within design parameters. The inverter finned aluminum heat sink is located on the back side of the inverter in the condenser air stream. If the alert code 440 occurs frequently, especially at lower outdoor temperatures, check the heat sink for debris that may reduce heat transfer or possible obstructions that may impact air flow across the heat sink. The inverter will begin to briefly reduce the compressor speed when the heat sink temperature rises above 167°F and will allow the inverter to resume the requested compressor demand speed once the inverter heat sink reaches 150°F. The heat sink temperature, compressor speed in Hertz and the Inverter Compressor Speed Reduction status ("On" or "Off ") notification can be viewed under the outdoor unit Diagnostics section of the thermostat dealer control center on units installed with an S40 thermostat.
E441	14	1 flash	4 flashes	Dealer Info Only	Compressor slowdown due to high compressor current. Compressor current is approaching limit. The compressor speed automatically slows. The control sets indoor CFM and outdoor RPM to values according to demand percentage rather than the actual Hz. Alarm is automatically cleared.	This error code is primarily for informational purposes as the inverter controls the compressor to operate within design parameters. Alert code 441 typically occurs at startup as the compressor as the currently increases rapidly during startup. The inverter will reduce the compressor speed by 4 hz and slow the compressor ramp up speed to the requested compressor demand (capacity). This is normal and expected operation of the inverter to control the compressor within design parameters. In most cases the alert code 441 does not require any additional service or diagnostic procedures. E441 may also occur if the system is operating at high pressures.
E442	N/A	N/A	N/A	Service Urgent	The top cap switch has opened five times within one hour. As a result, the outdoor unit is locked out.	When compressor thermal protection sensor opens five times within one hour, outdoor stops working. To clear, disconnect power to the indoor unit (24VAC power source to the outdoor control) which will power off the outdoor control and will open the outdoor unit contactor, which interrupts power to the inverter and then re-apply power.
E443	N/A	N/A	N/A	Service Urgent	Incorrect appliance unit size code selected.	Check for proper configuring of unit size codes for outdoor unit in configuration guide or in installation instructions. If replacing inverter, verify inverter model matches unit size. The alarm/ fault clears after the correct match is detected following a reset. Remove the thermostat from the system while applying power and reprogramming.
E600	N/A	N/A	N/A	Dealer Info Only	Compressor has been cycled OFF on utility load shedding.	Load shedding function: Provides a method for a local utility company to limit the maximum power level usage of the outdoor unit. The feature is activated by applying 24 volts AC power to the L and C terminals on the outdoor control.

TABLE 10. Outdoor Control 7-Segment Display Alert Codes and Inverter LED Flash Codes

NOTE – System fault and lockout codes take precedence over system status codes (cooling, heating operating percentages or defrost / dehumidification). Only the latest active fault or lockout codes are displayed (if present). If no fault or lockout codes are active, then system status codes are displayed. Alert codes are also displayed on the S40 thermostat.

Alert Codes	Inverter Code	Inverter LED Flash Code (number of flashes)		Priority	Alarm Description	Possible Causes and Clearing Alarm
		Red LED	Green LED			
E601	N/A	N/A	N/A	Dealer Info Only	Outdoor unit has been cycled OFF on low temperature protection.	Low temperature protection: Outdoor unit will not operate when the outdoor temperature is at or below -4°F (-20°C). If the unit is operating and the outdoor temperature drops below -4°F (-20°C), the unit continues to operate until the room thermostat is satisfied or the outdoor temperature drops to -15°F (-26°C). Outdoor unit ambient sensor provides temperature readings.

POWER-UP / RESET:

7-SEGMENT POWER-UP DISPLAY STRING

FIRMWARE VERSION: During initial power-up or reset, the first item displayed is the outdoor control firmware version. Example to the right shows firmware version 2.3.



UNIT TYPE: The next item displayed is the self discovery unit type. AC = air conditioner and HP = heat pump. If the unit type cannot be determined, three bars appear.

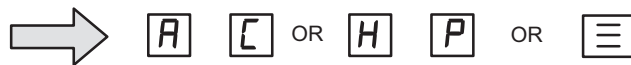

UNIT NOMINAL CAPACITY: The next item to be displayed is the self-discovery unit nominal capacity. Valid capacities are 24 for 2-ton, 36 for 3-ton, 48 for 4-ton and 60 for 5-ton units. If the unit type cannot be determined, three bars appear.



UNIT CODE: The next item to be displayed is the self discovery unit code. (may be a single character or two characters). If the unit code cannot be determined, three bars appear.



(These are just examples of firmware version, unit type, unit nominal capacity and unit codes.)

UNIT CODE	UNIT TYPE, SIZE AND MODEL	
☰	NOT PROGRAMMED	
84	2-TON HEAT PUMP	SL22KLV-024
85	3-TON HEAT PUMP	SL22KLV-036
86	4-TON HEAT PUMP	SL22KLV-048
87	5-TON HEAT PUMP	SL22KLV-060

7-SEGMENT POWER-UP DISPLAY STRING EXAMPLE

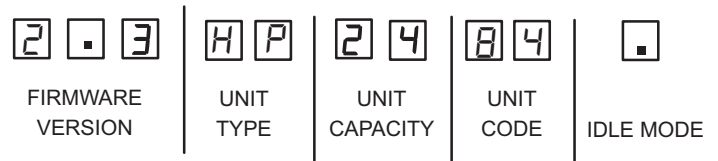

FIGURE 17. Outdoor Control 7-Segment Unit Status Displays

TABLE 11. Outdoor Control 7-Segment Unit Status Displays

Description	Example of Display
Idle Mode: Decimal point flashes at 1 Hz.	Idle Mode: Decimal point flashes at 1 Hz (0.5 second on, 0.5 second off). Display OFF.
Soft Disable Mode: Top and bottom horizontal line and decimal point flash at 1 Hz. If indoor or outdoor control displays Soft Disable code: 1) Confirm proper wiring between all devices (thermostat, indoor and outdoor). 2) Cycle power to the control that is displaying the Soft Disable code. 3) Put the room thermostat through Setup. 4) Go to Setup/System Devices/Thermostat/Edit/push Reset. 5) Go to Setup/System Devices/Thermostat/Edit/push Reset All. If the room thermostat detects a new device or a device that is not communicating, it sends a Soft Disable. When this occurs, Alarm 10 is activated and the room thermostat sends a Soft Disable command to the offending device on the bus (outdoor control, IFC, AHC, EIM or Damper Control Module).	Soft Disable Mode: Top and bottom horizontal line and decimal point flash at 1 Hz (0.5 second on, 0.5 second off). The iComfort control in Soft Disable Mode is indicated by the following: • On AHC, IFC and outdoor controls, Soft Disable Mode is indicated by flashing double horizontal lines on the 7-segment display. • On the Damper Control Module and EIM, the green LED will blink 3 seconds on and 1 second off.
O.E.M. Test Mode	All segments flashing at 2 Hz (unless error is detected). NOTE - Control should be replaced.
Anti-Short-Cycle Delay	The middle line flashes at 1 Hz for 2 seconds, followed by a 2-second display of the number of minutes left on the timer (value is rounded up: 2 min. 1 sec. is displayed as 3). If activated, the anti-short cycle delay time remaining is displayed (default is 300 sec./5 min.).
Cooling Capacity: Shows current cooling capacity demand percentage of maximum capacity. Example to the right indicates a cooling demand of 50 percent.	Cooling compressor demand percentage (1second on, 0.5 second off) followed by ambient temperature. S40 communicating thermostat with 50% demand and ambient of 95F: C 5 0 pause A 9 5 Repeat C 5 0 pause A 9 5
Heat Pump Heating Capacity: Shows current heat pump heating capacity demand percentage of maximum heating capacity. Example to the right indicates a heating demand of 33 percent.	Following string is repeated if heat pump is active. Note - r - if available, displays outdoor ambient temperature. S40 Heat Pump Heating Demand of 33% with an outdoor ambient of 40 F. H33 pause r 4 0
Diagnostic recall: Shows the last 10 stored diagnostic error codes.	If first error is E 2 5 0, second E 2 3 1 pause E 2 5 0 pause E 2 3 1 Next codes (up to 10) are shown using same method.
Fault memory clears	If there are no error codes stored: E pause 0 0 0. After the fault memory is cleared, the following string flashes every 0.5 seconds: 0 0 0 0 pause
Active error in outdoor control Idle mode: Show all active error(s) codes.	Following display string is repeated if Error E 125 and E 201 are present: E 1 2 5 pause E 2 0 1
Active error in run mode: Show current status and all active error(s) codes.	Following display string is repeated if Error E 440 is present while cooling demand is 80 percent: C 8 0 pause E 4 4 0
Outdoor Ambient Temperature (OAT): Any time OAT is within operating range, value is displayed if unit is in diagnostic and non-diagnostic modes.	Following display string is repeated if cooling is active and OAT is 104°F: C 3 5 pause A 1 0 4 pause
Liquid Line Temperature (LIQ): Any time LIQ is sensed in operating range, value is displayed if unit is in diagnostic mode or manually enabled for non-diagnostic modes.	Following display string is repeated if cooling is active and LIQ is 105°F: C 3 1 pause L 1 0 5 pause
Defrost Mode: Shown only while active defrost.	The following string is repeated if defrost is active: dF pause Repeat

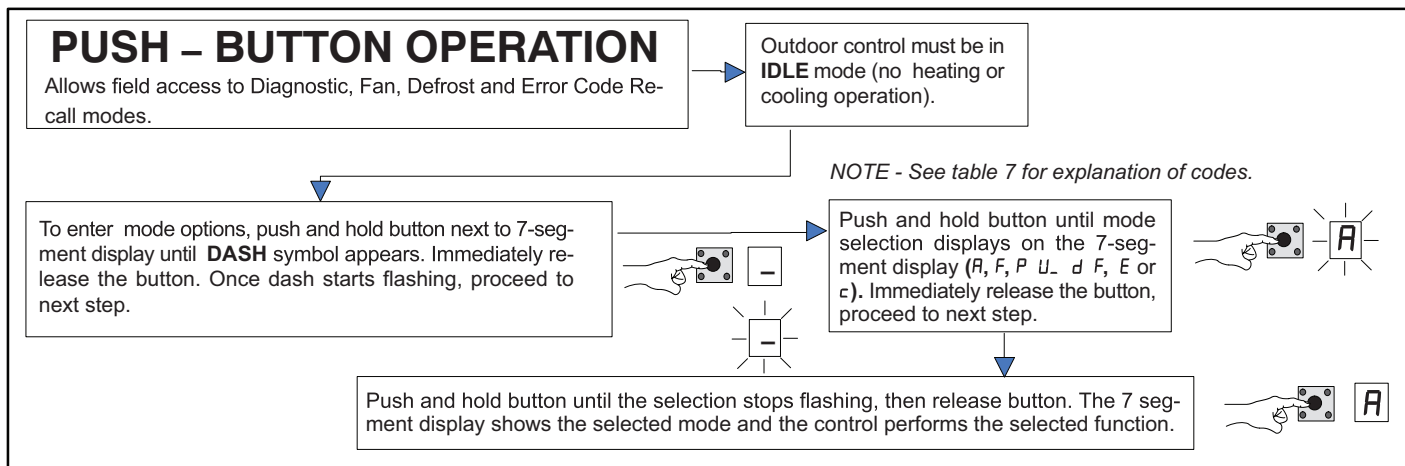

FIGURE 18. Push-Button Operation

Unit Selection Code for Outdoor Control

If the single-character display shows three (3) horizontal lines, the unit selection code needs to be programmed. Press and hold the button until the *P U* menu option is displayed, release button. The single-character display displays the selected mode per example in figure 25 on page 49. When the desired unit selection code appears, press and hold the button until it stops flashing, then release.

Unit Code	Unit Type	Unit Model
84	2-ton heat pump	SL22KLV-024
85	3-ton heat pump	SL22KLV-036
86	4-ton heat pump	SL22KLV-048
87	5-ton heat pump	SL22KLV-060

Idle mode – System is energized with no demand – Decimal flashes at 1 Hertz > 0.5 second ON. 0.5 second OFF

Display Symbol or Character	Display	Fan Test and Display String Option
Displayed during start-up or power recycling	Display string shows outdoor control firmware version <i>1 5</i> > pause > <i>A C</i> or <i>H P</i> unit > pause > unit capacity in BTUs > pause > unit code. If 3 horizontal bars are displayed during any sequence of this display string, it indicates that the specific parameter is not configured.	
.	Idle mode — decimal flashes at 1 Hertz > 0.5 second ON, 0.5 second OFF	
<i>C</i> or <i>H</i>	Indicates either cooling (C) or heating (H) mode compressor demand percentage, i.e. <i>C 9 0</i>	
<i>F</i>	Indicates control is in the outdoor fan test mode	Control must be in Idle mode: To enter fan test option - <i>F</i> mode, push and hold button until solid — appears, release button. Display begins flashing. Within 10 seconds, push and hold button until required symbol <i>F</i> displays, release button. Display begins flashing. Within 10 seconds, push and hold button until display stops flashing, release button. Control will initiate outdoor fan operation. Outdoor fan cycles ON for 10 minutes at the highest speed. To exit test – Push and hold button until three horizontal bars display. Release button, outdoor fan cycles OFF .
<i>dF</i>	Indicates system is in Defrost Mode	Displays <i>dF</i> when system is in defrost mode. To enter defrost, unit must be running in the heating mode, outdoor ambient temperature must be below 65F and outdoor coil temperature must be below the defrost termination temperature.
<i>A</i>	<i>A</i> in the display string represents the ambient temperature in °F at the sensor on the outdoor unit.	Control can be in Idle or demand mode: To enter display configuration option - <i>A</i> mode, push and hold button until solid — appears, release button. Display begins flashing. Within 10 seconds, push and hold button until required symbol <i>A</i> displays, release button. Display begins flashing. Within 10 seconds, push and hold button until display stops flashing, release button. Display shows error (E) code(s) and ambient (A), outdoor coil (c) and liquid (L) temperatures in Fahrenheit. NOTE - If button is not pushed in the 10-second time period, the control exits the test mode. If this occurs, test mode must be repeated.
<i>L</i>	<i>L</i> in the display string represents the liquid line temperature in °F	Control can be in Idle or demand mode: Display will show error (E) codes and ambient (A) and liquid (L) temperature in Fahrenheit.
—	Soft Disable Mode	

Error Code Recall Mode (NOTE – control must be in idle mode)	
E	To enter error code recall mode, push and hold button until solid E appears, then release button. Control displays up to 10 error codes stored in memory. If E 0 0 0 0 is displayed, there are no stored error codes.
≡	To exit error code recall mode, push and hold button until solid three horizontal bars appear, then release button. Note - Error codes are not cleared.
c	To clear error codes stored in memory, continue to hold button while the 3 horizontal bars are displayed. Release button when solid c is displayed.
c	Push and hold for one (1) second, release button. 7-Segment displays 0 0 0 0 and exits error recall mode.

FIELD TEST MODE OPERATION

The field test mode allows the unit to be put into diagnostic mode and allows the installer to perform multiple tests on the control / unit.

Diagnostic Mode

Diagnostic mode is only available when the system is idle or during an active / suspended call for heating or cooling. Diagnostic mode is terminated when the exit command is given, the button is pressed and released without entering the diagnostic menu or 10 minutes has passed, whichever comes first.

When this mode is selected all installed temperature sensor valves (non-open and non-short) are shown on the 7-segment display. The following system status codes are displayed:

- Cooling
- Cooling or heat pump heating percentage demand operation
- Active error codes

Outdoor Fan Mode

Diagnostic mode is only available while the system is in idle mode. This mode can be exited with the proper command or after 10 minutes has passed.

In diagnostic mode, the control energizes the outdoor fan at the highest speed.

NOTE – Indoor fan will remain off.

Forced Defrost Mode

The field test mode allows the technician to initial a Forced Defrost Test. using the unitary control push button.

- While the SL22KLV is operating in the heating mode, press pushbutton until solid “-” is displayed to enter Field Test Mode and then release the button.
- Press and hold the button until “d” is displayed for Forced Defrost cycle, then release the button. Press the button again while the display is flashing “d” to select the Forced Defrost Mode.
- The SL22KLV will enter a Forced Defrost Cycle and “d”+“F” will be display on the 7-segment display.
- Coil “c” and Ambient “A” temperature will be displayed on 7-segment display.
- Compressor operates at full Cooling Hertz during defrost.

NOTE – Auxiliary heat will not be enabled during a forced defrost.

NOTE – “Defrost Now” under S40 Tests only provides a 30s Defrost & ignores Ambient & Coil Temperature.

Exiting a Forced Defrost Cycle

- Defrost is terminated upon reaching the defrost termination temperature setting.
- Defrost is terminated on the maximum allowable normal defrost time (14 minutes).
- Defrost will end after 10 seconds if the ambient is 65F or greater.
- Push button is pressed.

TABLE 12. Field Test, Diagnostic Recall and Program Menu Options

Display	Display and action (normal operation)
No Change - idle (*)	No Change - idle (*)
Solid .	Enter or exit field test and program mode.
Solid R	Puts unit in diagnostic mode. (Displays ambient temperatures and any active error codes.)
Solid c	Clears error history (**)
Solid d	Starts forced defrost test
Solid E	Enter diagnostic recall mode. Displays up to 10 error codes in memory.
Solid F	Starts outdoor fan.
String P U	Enter unit code programming.

*No change indicates the display will continue to show whatever is currently being displayed for normal operations.

**Note once the error history is deleted it cannot be recovered. After the history is deleted, the unit will reset itself.

Display	Display and action (normal operation)
.	Idle mode — decimal flashes at 1 Hertz > 0.5 second ON, 0.5 second OFF
C or H	Indicates either cooling (C) or heating (H) mode and demand percentage. Shows capacity percentage and outdoor ambient temperature. Example: C 5 0 pause R 7 5
E	E in the display string represents the active error code(s) in the outdoor unit. Example: C 5 0 pause E 4 4 pause E 4 4 2 pause R 7 5 pause
R	R in the display string represents the outdoor ambient temperature in °F at the outdoor sensor on the outdoor unit. Example: C 5 0 pause R 7 5

TYPICAL 7-SEGMENT ACTIVE COOLING DEMAND DISPLAY STRING

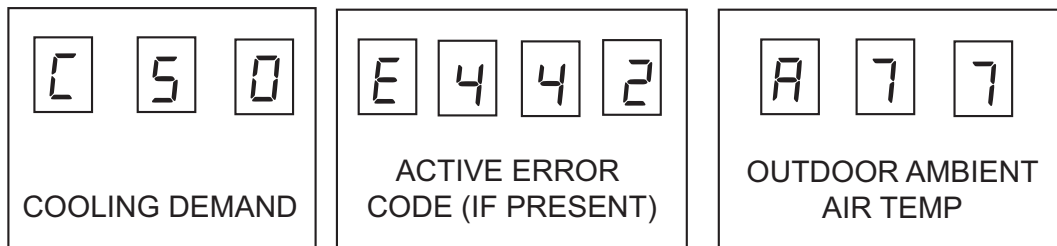

BY DEFAULT, COOLING DEMAND, ACTIVE ERROR CODES AND OUTDOOR AMBIENT TEMPERATURE ARE DISPLAYED.

FIGURE 19. Typical 7-Segment Demand Display String

Reconfiguring Outdoor Control using S40 Smart Wi-Fi Thermostat

Reconfiguring only applies to SL22KLV units as part of a fully communicating system and requires a communicating S40 thermostat and communicating indoor unit.

If any component of the HVAC system is changed, e.g. replacing an outdoor sensor, reconfiguring the system is required. To begin reconfiguring a system, select the Set-up tab.

System Overview

Refer to the applicable Thermostat Installer Setup Guide for configuration procedures.

The outdoor control provides the following functions:

- Internal switching of outputs.
- Compressor anti-short-cycle delay (adjustable through the thermostat interface).
- Five-strike lockout function.
- High Pressure protection using the High Pressure Switch (S4) and Low Pressure protection using the transducer.
- Ambient (RT13), liquid line (RT36), suction line (RT41) and discharge line (a9RT61) temperatures for monitoring, protection and discharge temperature.
- Suction Pressure Transducer (A168) and Liquid Pressure Transducer (A188) for monitoring, control and discharge pressure.

COMPRESSOR PROTECTION – FIVE-STRIKE LOCK-OUT

The five-strike lockout function is designed to protect the compressor from damage. The five-strike feature is used for both high (S4) and low (S87) pressure switches.

Resetting Five-Strike Lockout

Once the condition has been rectified, power to the outdoor control R terminal must be cycled OFF.

Diagnostic Information – Installations with S40 Smart Wi-Fi Thermostat

The following diagnostic information is available through the thermostat's user interface. Refer to the applicable Installer System Setup Guide.

- Compressor anti-short-cycle delay timer status
- Cooling or heating compressor demand rate
- High pressure switch status
- Low pressure (Low pressure switch is emulated by Suction Pressure Transducer)
- Suction pressure
- Liquid pressure
- Compressor top cap switch status
- Liquid line and suction line temperature
- Superheat and subcooling values

- Outdoor ambient temperature
- Compressor active alarm
- Compressor Hz
- Inverter compressor short cycle
- Heat sink temperature
- Defrost information including defrost Target Frost Accumulation, Frost Accumulation Time and Coil Temp.
- Reversing valve status
- Coil temperature
- Discharge superheat
- Discharge pressure
- Discharge temperature
- HP EEV position
- Liquid injection EEV position
- Liquid injection solenoid state

Installer Test – Using the S40 Thermostat or Lennox Dealer Setup App.

Verify the proper operation of the system by running the Installer Test feature through the thermostat interface or Lennox Dealer Setup App. The Lennox Dealer Setup App is available to download at the Apple App Store or on Google Play for Android smart phones. Refer to the applicable Installer System Setup Guide.

COMPRESSOR SHORT CYCLING DELAY

The outdoor control protects the compressor from:

- Short cycling (five minutes) during initial power-up.
- Interruption in power to the unit.
- Pressure or sensor trips.
- Delay after demand is removed.

The delay is set by default for 300 seconds (five minutes) but can be changed through the thermostat interface (iComfort S40 thermostat installations only).

Available settings are 60, 120, 180, 240 and 300 seconds.

CRANKCASE HEATER (HR1)

Compressors in all units are equipped with a 40-watt bellyband- type crankcase heater. HR1 prevents liquid from accumulating in the compressor. HR1 is controlled by the crankcase heater thermostat.

CRANKCASE HEATER THERMOSTAT (S40)

Thermostat S40 controls the crankcase heater located around the compressor in all units. S40 is located on the compressor shell. When liquid line temperature drops below 50°F, thermostat S40 closes, energizing HR1. The thermostat opens, de-energizing HR1, once liquid line temperature reaches 70°F.

Defrost Function

The outdoor unit control uses a time dependent frost accumulation duration demand defrost control algorithm to provide a demand defrost when the system falls below optimum levels. The demand defrost control algorithm is reactive based upon the previous heat pump run time between defrost cycles (frost accumulation time) and the time spend in defrost (defrost time). The outdoor unit control monitors ambient temperature, outdoor coil temperature along with the compressor run time in heating mode and defrost cycle time. The outdoor unit control monitors compressor run time in the heating mode when the outdoor coil temperature is below 35°F and accumulates the frost accumulation time.

Once the frost accumulation time is met the unit control will initiate a defrost cycle. The unit will run in the defrost mode until the coil temperature reaches the defrost termination temperature setpoint. The maximum length of defrost cycle is 14 minutes and the defrost cycle will automatically be terminated if the defrost cycle exceeds 14 minutes.

Two consecutive low pressure switch trips while operating in the heat pump heating mode will initiate a defrost cycle to defrost that may occur during a weather related event such as freezing rain.

Frost Accumulation Time

The frost accumulation time is the amount of time the heat pump runs in the heating mode when the outdoor coil temperature is below 35°F. The initial target frost accumulation time is 90 minutes, but the control will adjust the frost accumulation time higher or lower based upon the previous defrost cycle time history. If the defrost cycle time is short (80% or less of the defrost cycle time) the defrost accumulation time will be increased by 30 minutes. If the defrost cycle time is long (120% or more of the target defrost cycle time) the defrost accumulation time will be decreased by 30 minutes. If the defrost accumulation time is significantly longer (200% or more of the target defrost cycle time) or if the defrost terminates at the 14-minute maximum time, the frost accumulation time is set to 30 minutes. No change is the frost accumulation time is made if the frost accumulation time is close to the target defrost cycle time (between 80% and 120% of the target defrost cycle time).

Low Ambient Defrost

When outdoor temperature is less than 10°F, the Frost Accumulation Time will be set to 360 minutes. When the outdoor temperature is extremely cold, there is less moisture in the air, which reduces the defrost frequency requirements. Setting the frost accumulation time to 360 minutes will reduce the defrost cycle frequency which will increase the overall system efficiency and minimize operation costs. The Low Ambient Defrost had adjustable parameters, allowing the technician to make adjustments for the special application and climate.

Defrost Cycle Time

The defrost cycle time is the amount of time the unit operates in the defrost mode from the point the defrost cycle was initiated until the coil temperature reaches 50°F regardless of defrost termination temperature setpoint. The demand defrost control target defrost cycle time is unique for each SL22KLV heat pump model. The target defrost cycle time of SL22KLV-024 is 100s, SL22KLV-036 is 120s, SL22KLV-048 is 190s, SL22KLV-060 is 200s.

Defrost Termination Temperature

The defrost termination temperature is adjustable using the S40 thermostat. The Defrost Termination parameter may be adjusted at the thermostat using the dealer control center under the heat pump or remotely using the Service Dashboard on LennoxPros. The defrost termination setting selections are 50, 70, 90 and 100°F. The factory default setting is 50°F (10°C). The defrost termination temperature is monitored by the coil sensor which is located at the outlet of the outdoor expansion valve. See coil sensor figure location below for details.

The Unitary Control has a defrost termination jumper to allow the installer to set the defrost termination temperature using the jumper on the Unitary Control, prior to connecting the SL22KLV to the S40 communicating thermostat. Once the SL22KLV is connected to the S40 thermostat, the Defrost Termination Jumper on the Unitary control is ignored. The defrost termination setting must be changed using the thermostat Dealer Setup > Equipment > Heat Pump > Defrost termination temperature.

NOTE – *Colder climates may require a higher defrost termination temperature setting to ensure the outdoor coil is cleared of frost during defrost. If the outdoor coil is not adequately cleared of frost, the heat pump may experience reduced heating performance or damage to the outdoor coil from the buildup of ice on the coil.*

Defrost Termination Temperature Setting Parameter in the S40

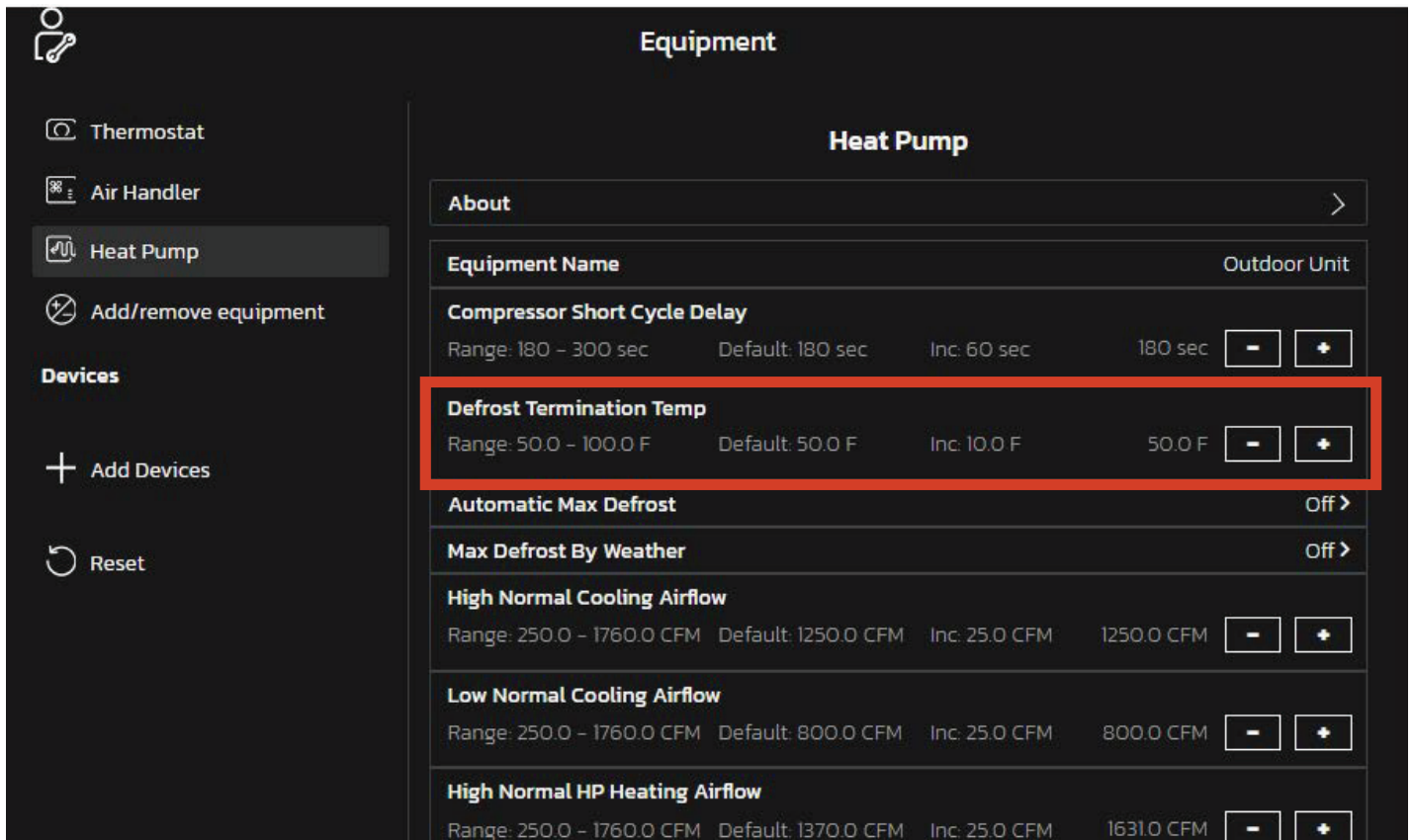

FIGURE 21. Defrost Coil Sensor Location

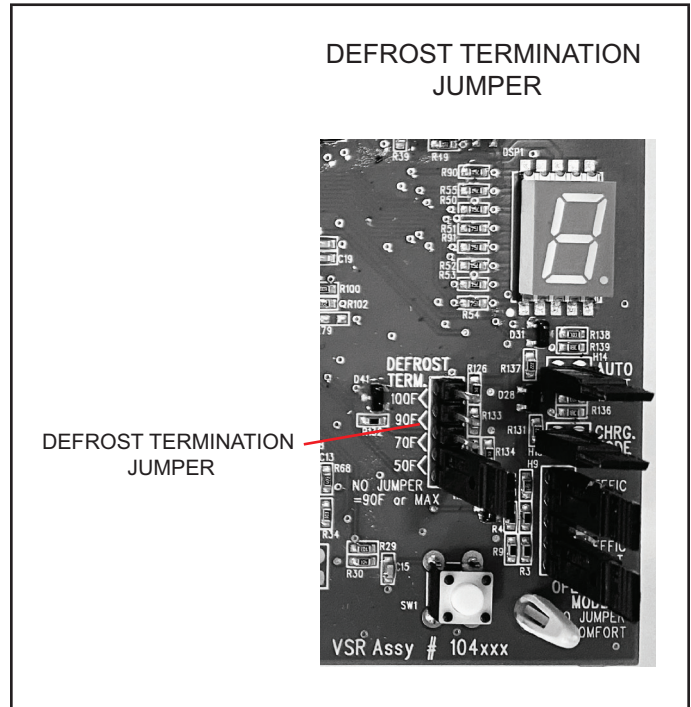

FIGURE 22

Maintenance

Outdoor Unit

Maintenance and service must be performed by a qualified installer or service agency. At the beginning of each cooling season, the system should be checked as follows:

- 1 - Clean and inspect outdoor coil (may be flushed with a water hose). Ensure power is off before cleaning.
- 2 - Outdoor unit fan motor is factory-lubricated and sealed. No further lubrication is needed.
- 3 - Visually inspect all connecting lines, joints and coils for evidence of oil leaks.
- 4 - Check all wiring for loose connections.
- 5 - Check for correct voltage at unit (unit operating).
- 6 - Check amp draw on outdoor fan motor.
- 7 - Inspect drain holes in coil compartment base and clean if necessary.

NOTE - *If insufficient heating or cooling occurs, the unit should be gauged and refrigerant charge should be checked.*

Outdoor Coil

It may be necessary to flush the outdoor coil more frequently if it is exposed to substances which are corrosive or which block airflow across the coil (e.g., pet urine, cottonwood seeds, fertilizers, fluids that may contain high levels of corrosive chemicals such as salts).

- Outdoor Coil — The outdoor coil may be flushed with a water hose.
- Outdoor Coil (Coastal Area) — Moist air in ocean locations can carry salt, which is corrosive to most metal. Units that are located near the ocean require frequent inspections and maintenance. These inspections will determine the necessary need to wash the unit including the outdoor coil. Consult your installing contractor for proper intervals/procedures for your geographic area or service contract.

Indoor Unit

- 1 - Clean or change filters.
- 2 - Lennox blower motors are factory-lubricated and permanently sealed. No more lubrication is needed.
- 3 - Adjust blower speed for cooling. Measure the pressure drop over the coil to determine the correct blower CFM. Refer to the unit information service manual for pressure drop tables and procedure.
- 4 - Check all wiring for loose connections.
- 5 - Check for correct voltage at unit. (blower operating)
- 6 - Check amp draw on blower motor.

Indoor Coil

- 1 - Clean coil if necessary.
- 2 - Check connecting lines, joints and coil for evidence of oil leaks.
- 3 - Check condensate line and clean if necessary.

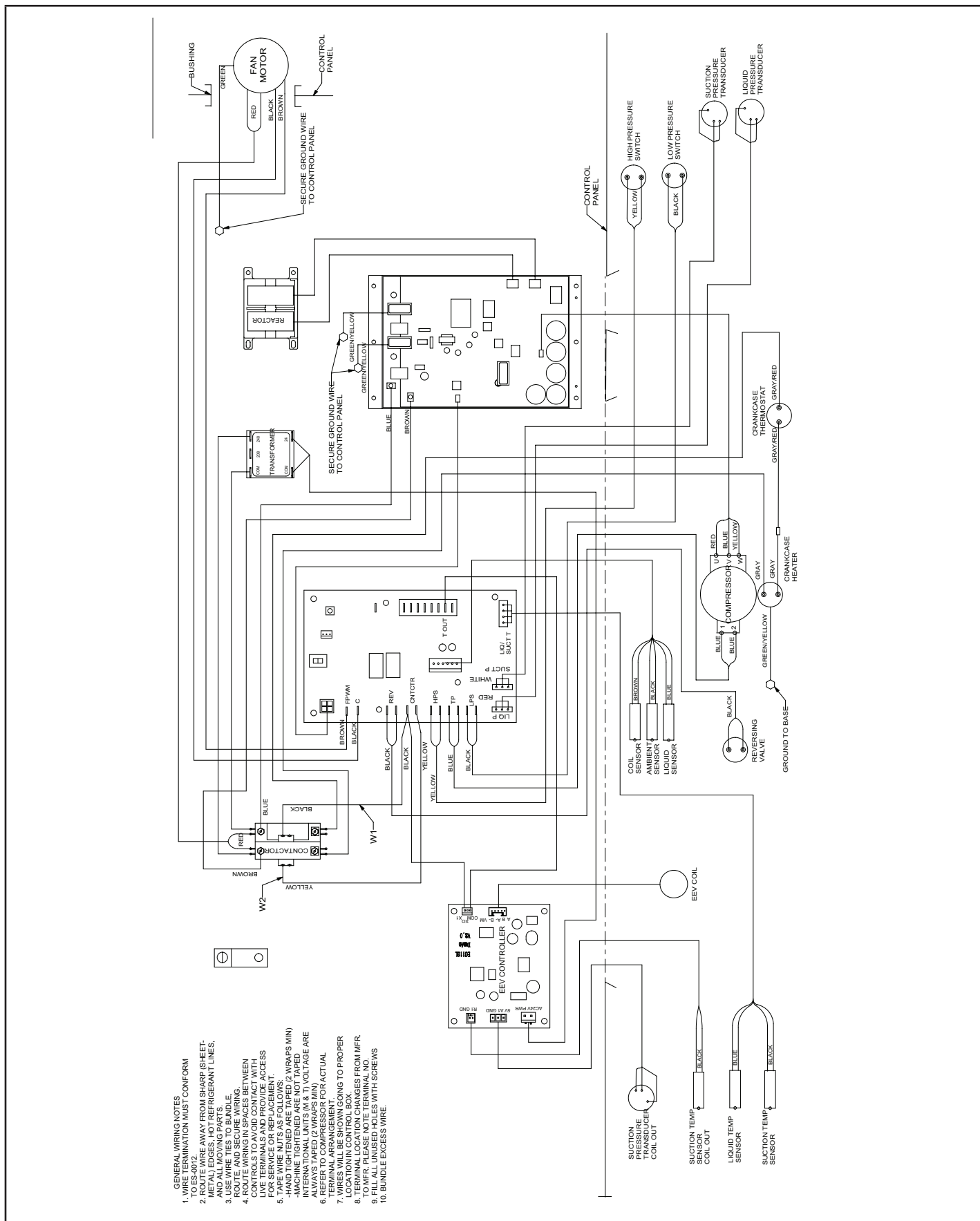

FIGURE 24. Typical Factory Wiring

Unit Sequence of Operation

The following figures illustrate the overall unit sequence of operation along with the operation of various pressure switches and temperature sensors. The figures also illustrate the use of the compressor anti-short-cycle function in relation to unit Status, unit Fault and lockout LED Codes and unit system operation interactions.

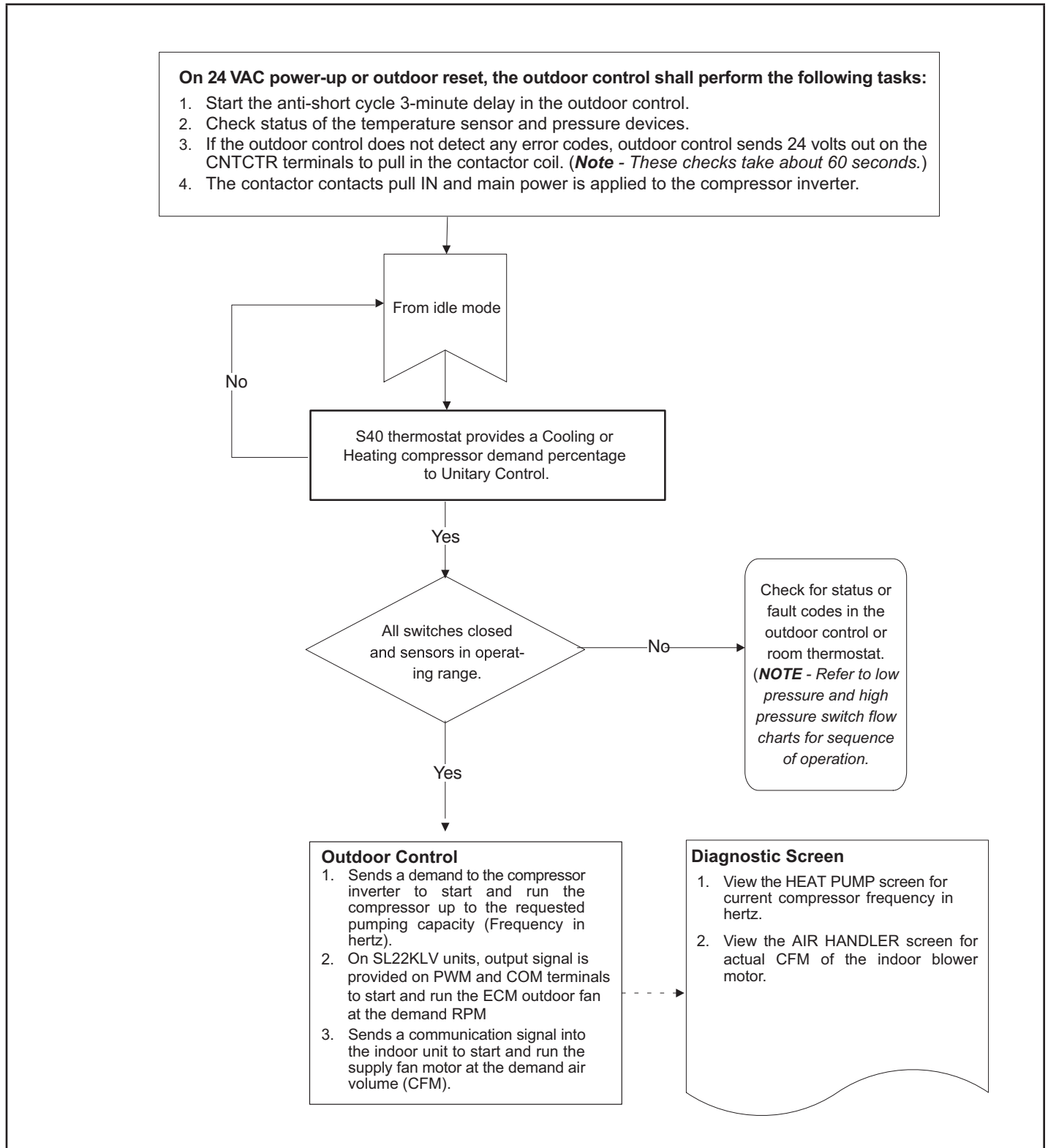

FIGURE 25. 24 Volt Power-Up or Outdoor Reset

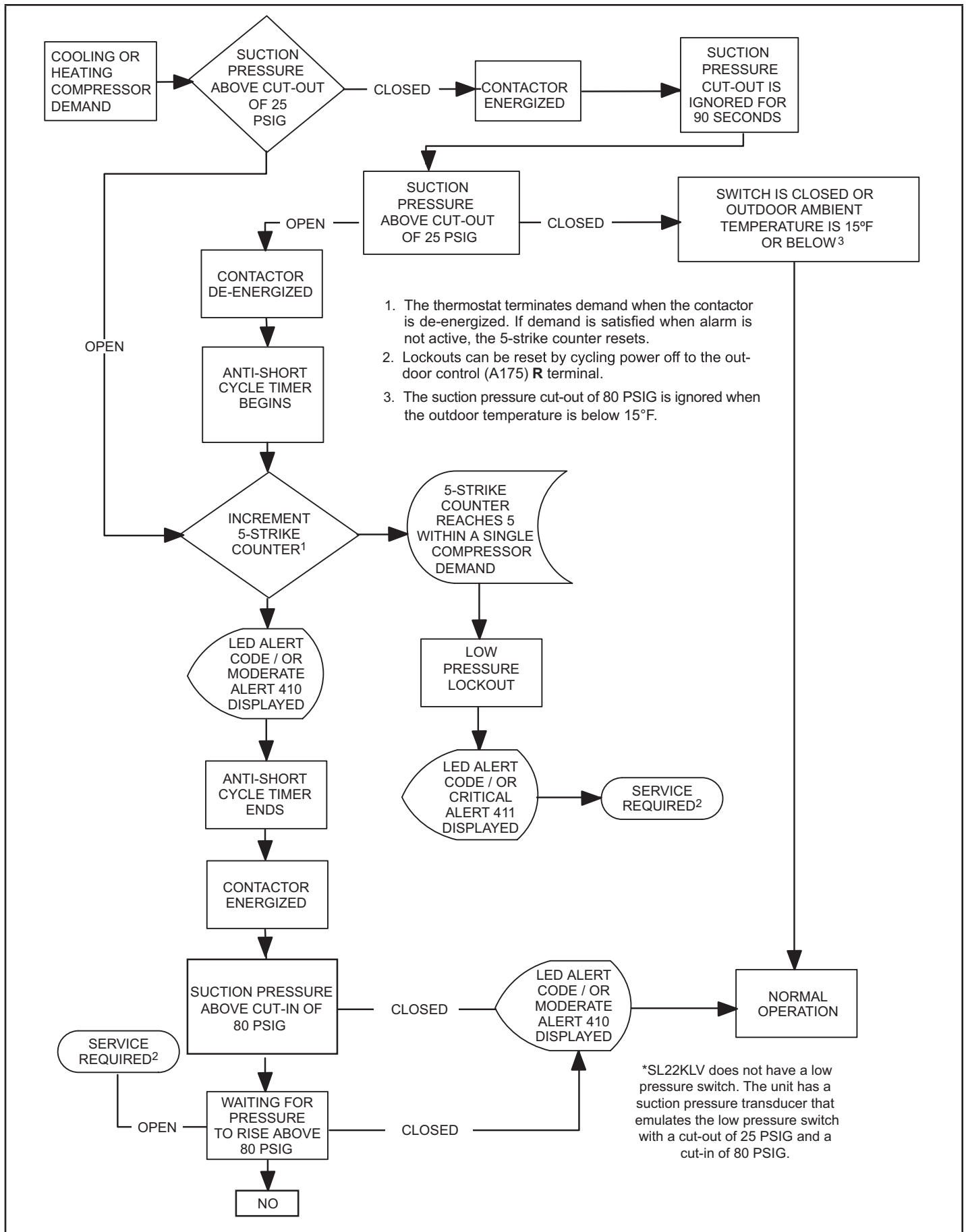

FIGURE 26. Suction Pressure Transducer (A168) Logic Sequence of Operation

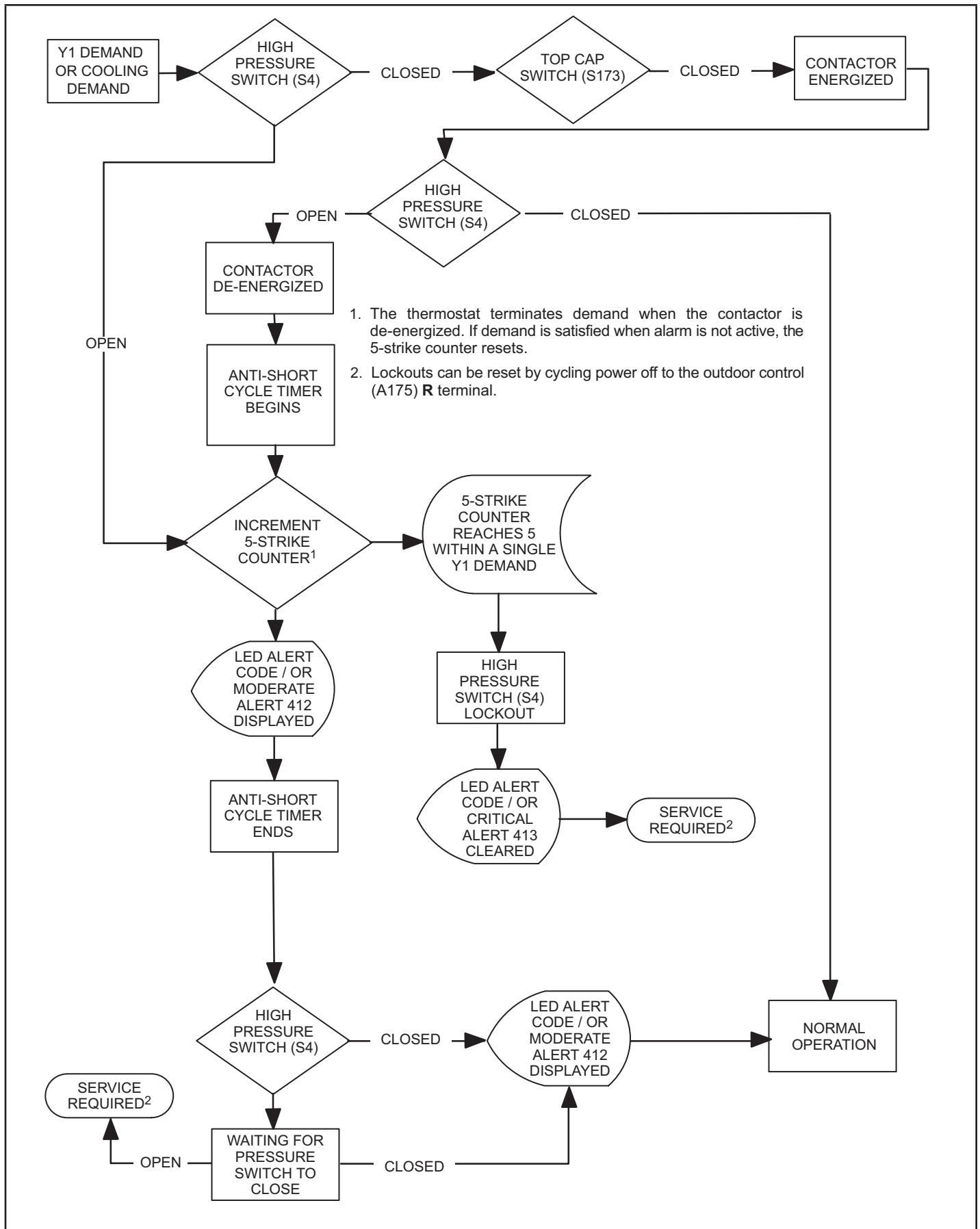

FIGURE 27. High Pressure Switch (S4) Sequence of Operation (All Units)

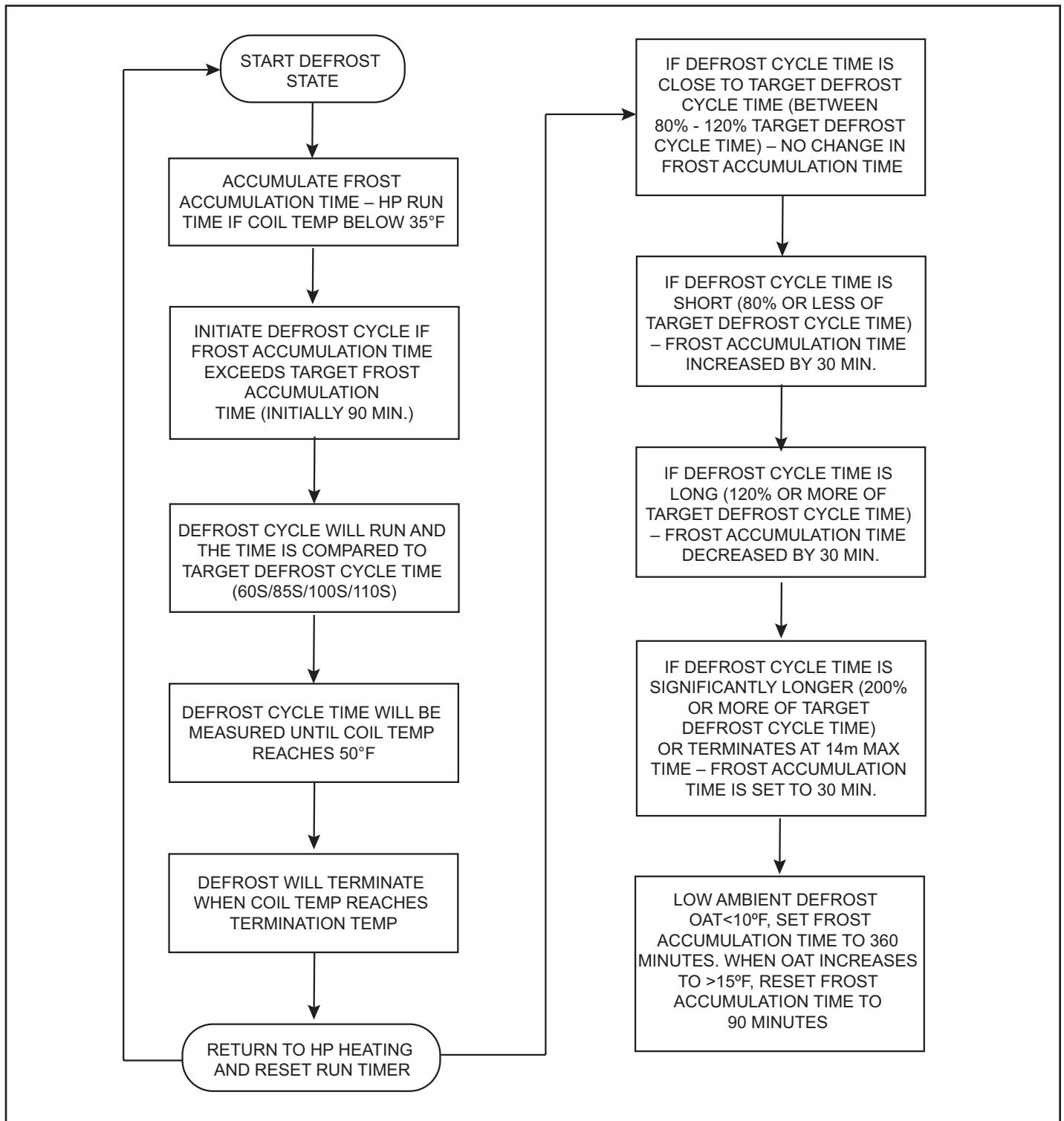

FIGURE 28. Demand Defrost Cycle – Sequence of Operation

Component Testing Table of Contents

Verifying Suction Pressure Transducer Operation	64	Top Cap Switch Operation.....	73
Verifying Liquid Pressure Transducer Operation.....	65	Reactor Operations.....	74
Compressor Operation, Checkout and Status / Error Codes ..	68	Outdoor Fan Operation.....	74
Crankcase Heater, Checkout and Status / Error Codes..	72	Outdoor Control Operation.....	77
Compressor Sound Cover.....	72	Unit Sensor Operations.....	77
Liquid Line Filter Drier.....	72	DC Inverter Control Operation.....	86

Verifying High Pressure Switch and Low Pressure Protection Operation

OPERATION:

The unit's pressure switch (HPS - S4) is wired into the the control HPS terminal.

NOTE - The SL22KLV does not have a low pressure switch and the LPS terminals are not jumpered. The unit has a suction pressure transducer that emualtes the low pressure switch with a cut-out of 25 PSIG and a cut-in of 80 PSIG. This provides the same protection as a traditional low pressure switch. In the event the suction pressure transducer fails, back up protection is provided by the suction temperature sensor wand and will open at 25F.

High Pressure Switch (HPS) – See figure 31 for high pressure switch sequence of operation.

Pressure Switch Event Settings

The following pressures are the auto-reset event value triggers for low and high pressure thresholds:

- High Pressure (auto-reset) - trip at 590 psig; reset at 418.
- Low suction pressure protection (suction pressure transducer emulate LPS) (Auto-reset) - Trips at 25 PSIG, reset at 90 PSIG (See figure 30)

CHECKOUT – S4 High Pressure Switch

Using a multimeter set to ohms with the terminals disconnected from the control board, check the resistance between the two terminals of the pressure switch. If the resistance reading is 0 ohms, the switch is closed.

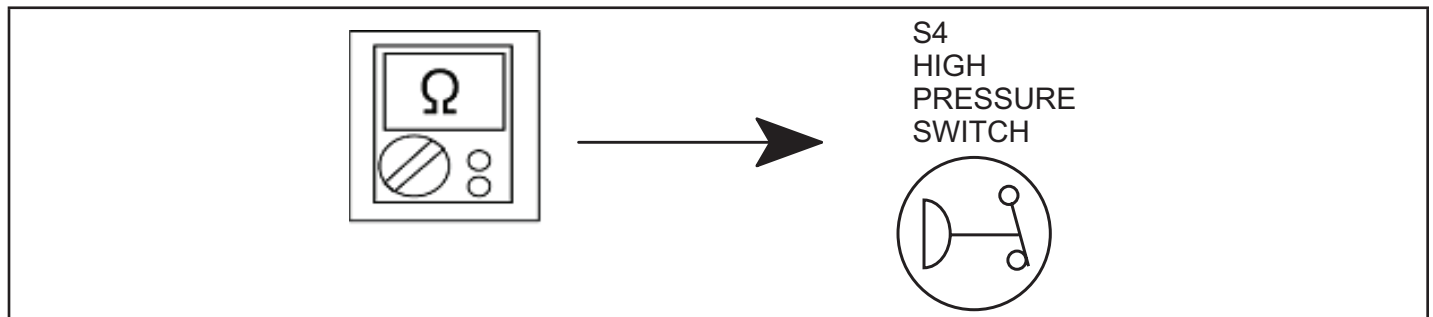

FIGURE 29. Verifying High-Pressure Switch Operation

Verifying Suction Pressure Transducer Operation

Using a multimeter set to VDC with the Suction Pressure Transducer connected to the "Suct/Liq" 4-pin connector on the control board. Pin 1 (Red wire +5VDC) to Pin 3 (Black wire - GND) should read 5 VDC continuous. Pin 2 (Blue wire output from transducer) to Pin 3 (Black - GND) should read 0.5 to 4.5 VDC and will vary depending on suction pressure measured. See Table 10.

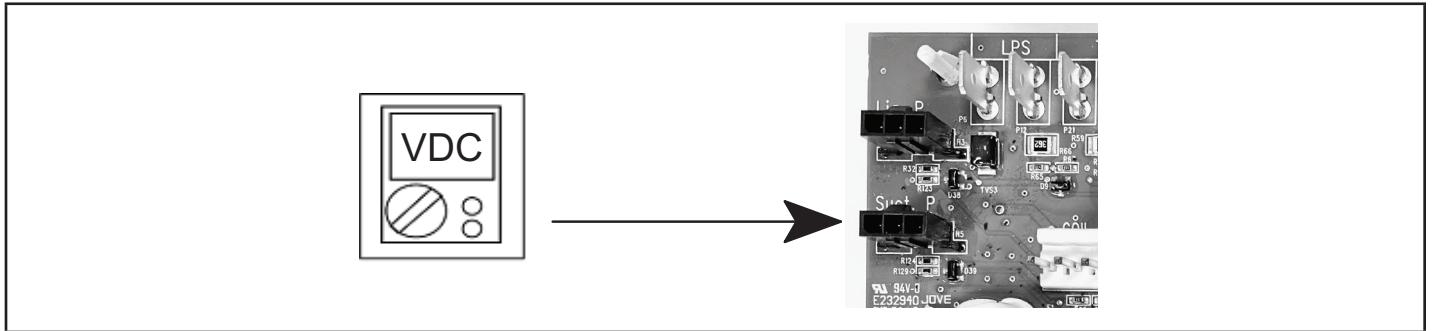

FIGURE 30. Suction Pressure Transducer Voltage

TABLE 13. Suction Pressure Transducer Output Voltage

Suction Pressure (PSIG)	DC Voltage Output (Pin 2 to Pin 3)	Suction Pressure (PSIG)	DC Voltage Output (Pin 2 to Pin 3)
0	0.49	110	2.69
10	0.69	120	2.89
20	0.89	130	3.09
30	1.09	140	3.29
40	1.29	150	3.49
50	1.49	160	3.69
60	1.69	170	3.89
70	1.89	180	4.09
80	2.09	190	4.29
90	2.29	200	4.49
100	2.49	210	4.50

Verifying Liquid Pressure Transducer Operation

Using a multimeter set to VDC with the Liquid Pressure Transducer connected to the "Suct/Liq" 4-pin connector on the control board. Pin 1 (Red wire +5VDC) to Pin 3 (Black wire - GND) should read 5 VDC continuous. Pin 2 (Blue wire output from transducer) to Pin 3 (Black - GND) should read 0.5 to 4.5 VDC and will vary depending on liquid~ pressure measured. See Table 11.

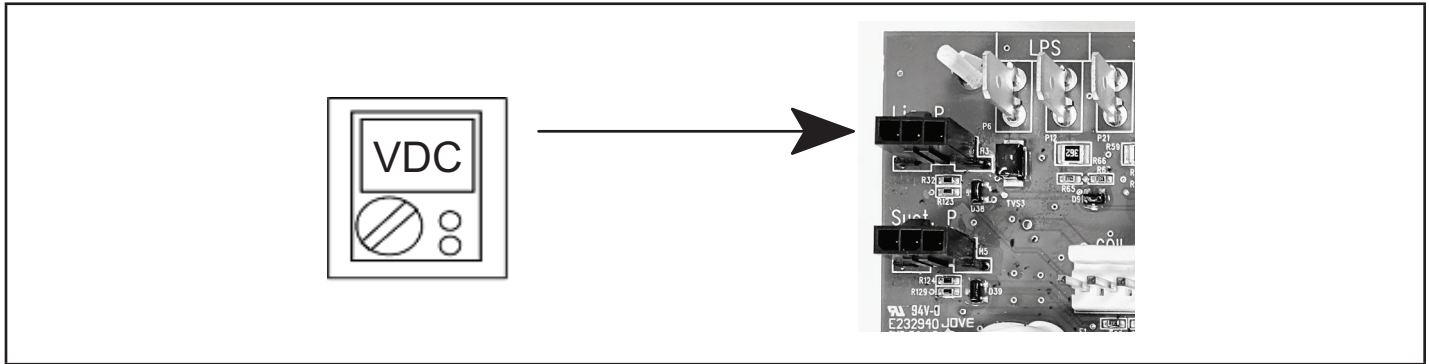

FIGURE 31. Liquid Pressure Transducer Voltage

TABLE 14. Liquid Pressure Transducer Output Voltage

Liquid Pressure (PSIG)	DC Voltage Output (Pin 2 to Pin 3)	Liquid Pressure (PSIG)	DC Voltage Output (Pin 2 to Pin 3)	Liquid Pressure (PSIG)	DC Voltage Output (Pin 2 to Pin 3)
0	0.50	210	1.90	420	3.30
10	0.57	220	1.97	430	3.37
20	0.63	230	2.03	440	3.43
30	0.70	240	2.10	450	3.50
40	0.77	250	2.17	460	3.57
50	0.83	260	2.23	470	3.63
60	0.90	270	2.30	480	3.70
70	0.97	280	2.37	490	3.77
80	1.03	290	2.43	500	3.83
90	1.10	300	2.50	510	3.90
100	1.17	310	2.57	520	3.97
110	1.23	320	2.63	530	4.03
120	1.30	330	2.70	540	4.10
130	1.37	340	2.77	550	4.17
140	1.43	350	2.83	560	4.23
150	1.50	360	2.90	570	4.30
160	1.57	370	2.97	580	4.37
170	1.63	380	3.03	590	4.43
180	1.70	390	3.10	600	4.50
190	1.77	400	3.17		
200	1.83	410	3.23		

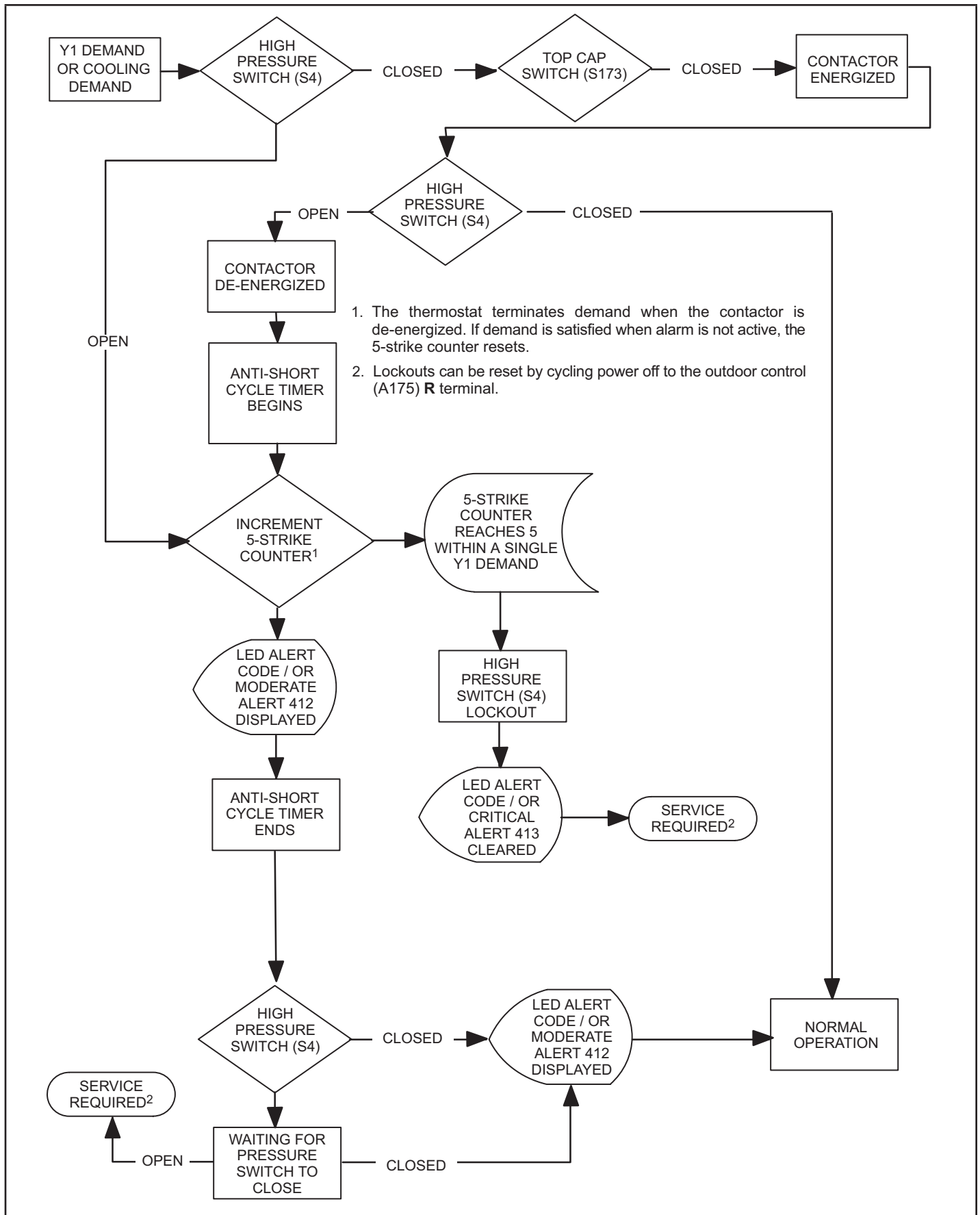

FIGURE 32. High Pressure Switch (S4) Sequence of Operation (All Units)

High Pressure Switch and Low Pressure Protection Errors

TABLE 15. Outdoor Control 7-Segment Display Alert Codes

System fault and lockout codes take precedence over system status codes (cooling, heating operating percentages or defrost/dehumidification). Only the latest active fault or lockout codes are displayed (if present). If no fault or lockout codes are active, then system status codes are displayed. Alert codes are also displayed on the communicating thermostat.

Alert Codes	Priority	Alarm Description	Possible Causes and Clearing Alarm
E 410	Service Soon	The outdoor unit cycled off due to low pressure protection logic.	Unit pressure is below the lower limit. The system is shut down. The suction pressure is below the suction pressure logic: opens below 25 PSIG and closes above 80 PSIG. Confirm that the system is properly charged with refrigerant. Check TXV, indoor unit blower motor, dirty filters or clogged refrigerant filter. Confirm that the evaporator coil is clean. The alarm clears after the pressure protection opens or after a power reset.
E 411	Service Urgent	The low pressure protection has opened 5 times within one hour. As a result, the outdoor unit is locked out.	Low pressure protection error count reached 5 strikes. The low pressure protection for R454B opens at 25PSIG and resets at 80PSIG. Confirm that the system is properly charged with refrigerant. Check for clogged TXV, blockage to indoor unit blower motor, dirty filters or clogged refrigerant filter. Confirm that the evaporator coil is clean. The alarm clears after a power reset.
E 412	Service Soon	The outdoor unit high pressure switch has opened.	Unit pressure is above the upper limit. System is shut down. The high pressure switch opens at 590PSIG and closes at 418PSIG. Confirm that the system is properly charged with refrigerant. Check for clogged TXV, blockage to indoor unit blower motor, clogged refrigerant filter. Confirm that the outdoor unit is clean. The alarm clears after the pressure switch closes or a power reset. For heating, indoor CFM may be set too low. For zoning system, zone CFM may be set too low.
E 413	Service Urgent	The high pressure switch has opened 5 times within one hour. As a result, the outdoor unit is locked out.	Open high pressure switch error count reached 5 strikes. System is shut down. The high pressure switch for HFC410A will open at 590PSIG and close at 418PSIG. Confirm that the system is properly charged with refrigerant. Check condenser fan motor, clogged TXV, blockage to indoor unit blower motor, stuck reversing valve or clogged refrigerant filter. Confirm that the outdoor unit is clean. The alarm clears after indoor power reset (24VAC power source to Outdoor Control)

Compressor Operation, Checkout and Status / Error Codes

OPERATION:

The SL22KLV units use a 380VAC three phase variable capacity R-Scroll compressor that is approved for use with R454B refrigerant. The compressor, when connected to an inverter, is capable of operating in a running frequency range from 20 hertz up to a maximum of 120 hertz. (maximum hertz is dependent on compressor size). The compressor speed is determined by S40 thermostat demand and in the heating mode, outdoor temperature.

CHECKOUT:

NOTE - The compressor motor winding resistance is the nominal resistance at 77°F. When measuring compressor motor winding resistance, the primary concern is the winding resistance between the different sets of terminals is within 10% of each other. The actual winding resistance is impacted by temperature, refrigerant and oil. Do not automatically condemn a compressor because the measured resistance is slightly higher or lower than the nominal resistance. Check for shorted/open windings and for shorts to ground during testing.

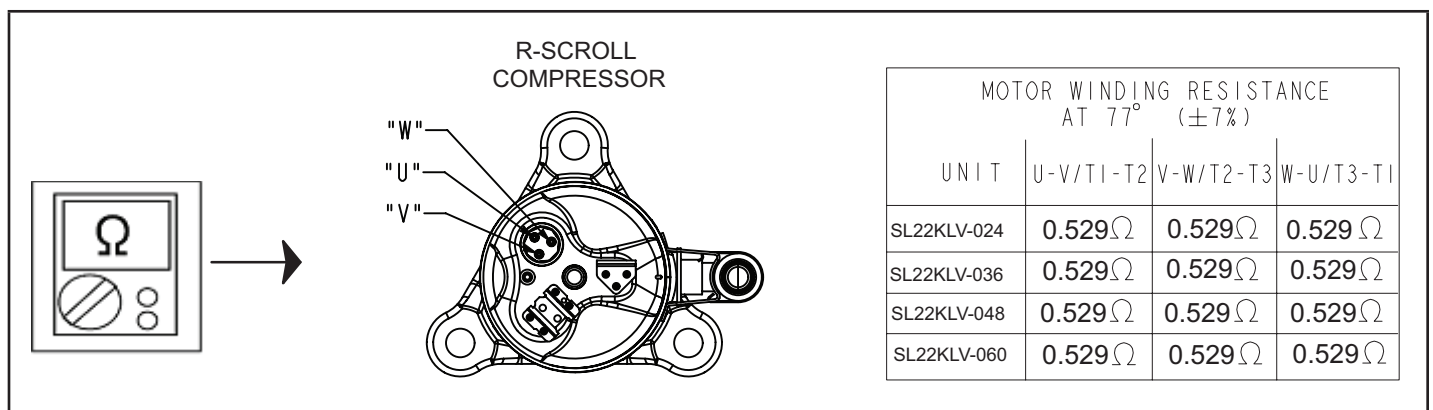
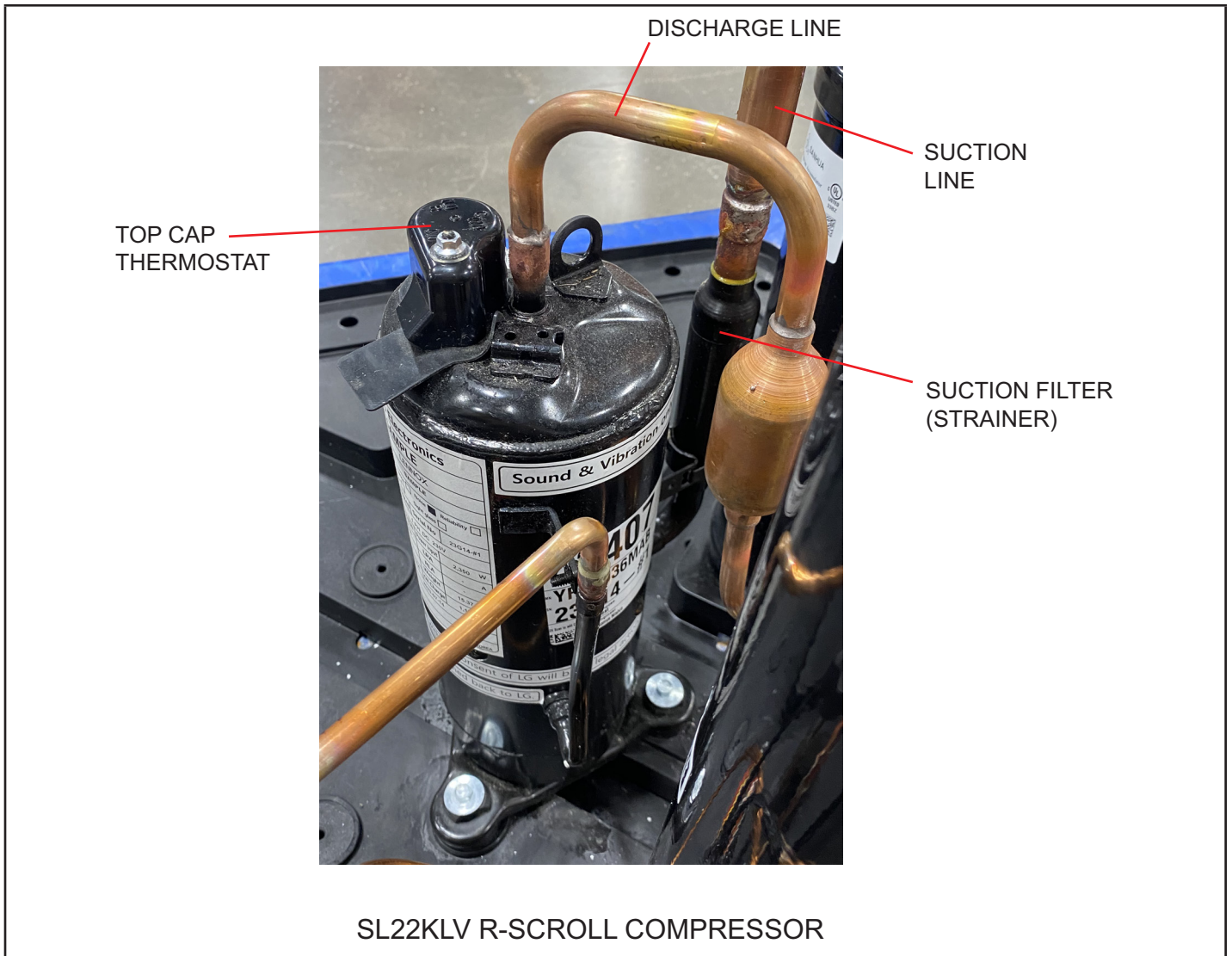

FIGURE 33. Compressor Operation, Checkout and Status/Error Codes

IMPORTANT: If compressor replacement is required, remove the compressor through the top of the unit. Removal through the access panel is not possible.



SL22KLV R-SCROLL COMPRESSOR
FIGURE 34. SL22KLV R-Scroll Compressor Detail

STATUS CODES:

When the compressor is running, the 7-segment display will show the demand as a percentage of compressor cooling or heating capacity, for example, C50 or H50.

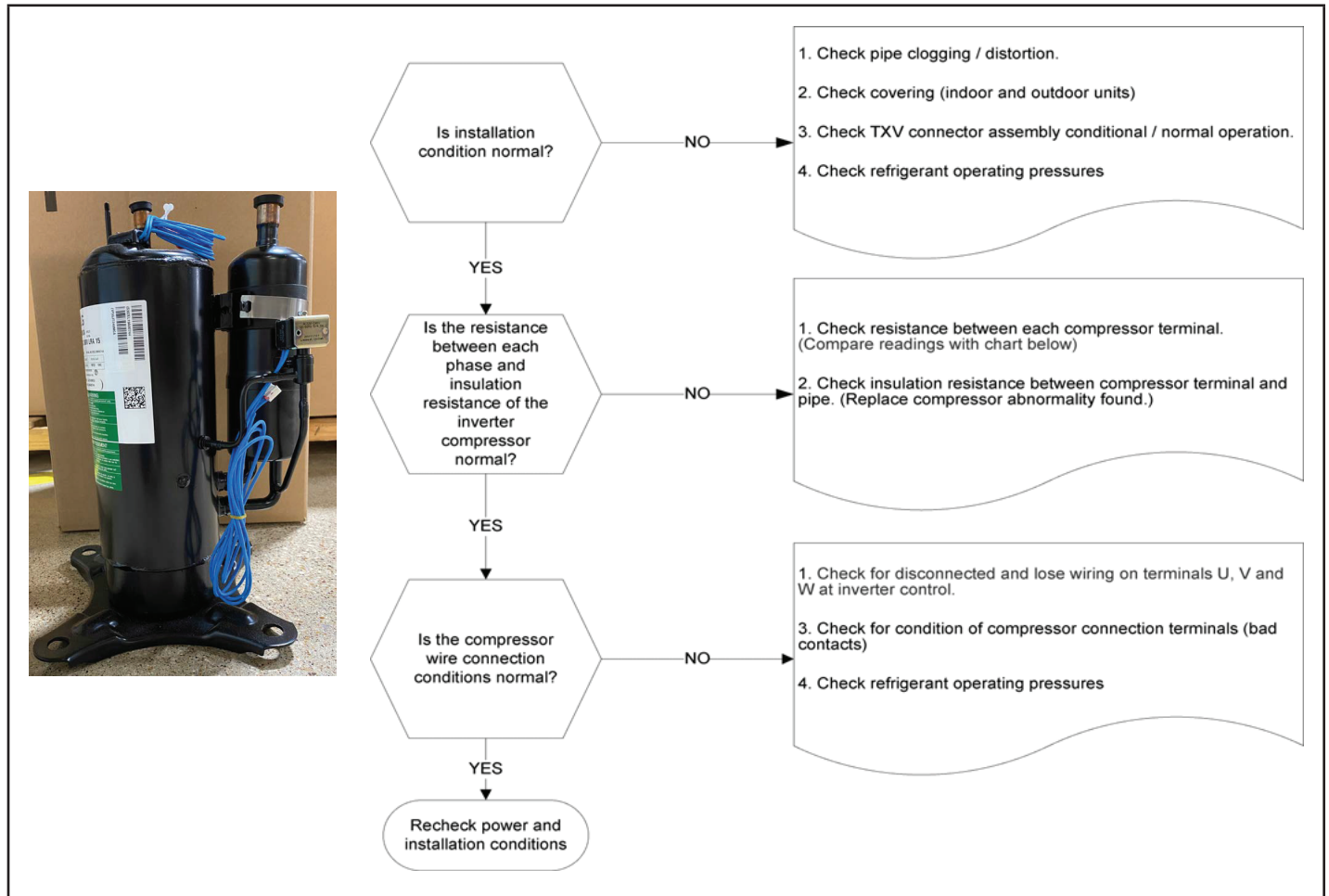

FIGURE 35. Compressor Operation, Checkout and Status/Error Codes

ERROR CODES:

TABLE 16. Outdoor Control 7-Segment Display Alert Codes - Compressor

System fault and lockout codes take precedence over system status codes (cooling, heating operating percentages or defrost/dehumidification). Only the latest active fault or lockout codes are displayed (if present). If no fault or lockout codes are active, then system status codes are displayed. Alert codes are also displayed on the S40 thermostat on systems installed with the S40 thermostat.

Alert Codes	Inverter Code	Inverter LED Flash Code (number of flashes)		Priority	Alarm Description	Possible Causes and Clearing Alarm
		Red LED	Green LED			
E 430	26	2 flashes	6 flashes	Service Soon/ Service Critical	Compressor start failure	This error code can occur when the difference between discharge and suction pressures is greater than 100 psig at startup. If condition is detected, outdoor unit compressor and fan stop. Antishort cycle is initiated. If condition occurs 10 times within an hour, system is locked out. Indicates poor connection at compressor harness, improper winding resistance, locked compressor rotor, or flooded compressor. To clear, disconnect power to the indoor unit (24VAC power source to the outdoor control) which will power off the outdoor control and will open the outdoor unit contactor, which interrupts power to the inverter and then re-apply power.

TABLE 16. Outdoor Control 7-Segment Display Alert Codes - Compressor

System fault and lockout codes take precedence over system status codes (cooling, heating operating percentages or defrost/dehumidification). Only the latest active fault or lockout codes are displayed (if present). If no fault or lockout codes are active, then system status codes are displayed. Alert codes are also displayed on the S40 thermostat on systems installed with the S40 thermostat.

Alert Codes	Inverter Code	Inverter LED Flash Code (number of flashes)		Priority	Alarm Description	Possible Causes and Clearing Alarm
		Red LED	Green LED			
E 433	29	2 flashes	9 flashes	Service Soon/ Service Critical	The inverter has detected a compressor over-current condition.	Error occurs when compressor peak phase current is greater than 28A. Inverter issues code 14 first and slows down to try to reduce the current. If the current remains high, outdoor unit compressor and fan stop. Antishort cycle is initiated. If condition occurs 5 times within an hour, the unitary control will cycle the contactor to prevent the system from locking out. To clear, disconnect power to the indoor unit (24VAC power source to the outdoor control) which will power off the outdoor control and will open the outdoor unit contactor, which interrupts power to the inverter and then re-apply power.
E 439	12	1 flash	2 flashes	Service Soon	Compressor slowdown due to high input current.	Input current is approaching a high limit. Compressor speed automatically slows. The control continues sending the inverter speed demanded by the thermostat. The control sets indoor CFM and outdoor RPM to values according to demand percentage rather than the actual Hz. Alarm is automatically clear.
E 440	13	1 flash	3 flashes	Dealer Info Only	Heat sink temperature is approaching limit. The compressor speed automatically slows to reduce heat sink temperature. The control sets indoor CFM and outdoor RPM to values according to demand percentage rather than the actual Hz. Alarm is automatically cleared.	This error code is primarily for informational purposes as the inverter controls the compressor speed to operate within design parameters. Typically the inverter will make a minor speed reduction of 4 Hz (approximately a 5-6% speed reduction) for a brief period of time and to reduce the heat sink temperature and will then resume normal operation. This may occur at high outdoor temperatures (above 110°F) for brief periods of time (3 – 4 minutes) and is normal and expected operation of the inverter controlling the compressor safely within design parameters. The inverter finned aluminum heat sink is located on the back side of the inverter in the condenser air stream. If the alert code 440 occur frequently, especially at lower outdoor temperatures, check the heat sink for debris that may reduce heat transfer or possible obstructions that may impact air flow across the heat sink. The inverter will begin to briefly reduce the compressor speed when the heat sink temperature rises above 167°F and will allow the inverter to resume the requested compressor demand speed once the inverter heat sink reaches 150°F. The heat sink temperature, compressor speed in Hertz & the Inverter Compressor Speed Reduction status ("On" or "Off ") notification can be viewed under the outdoor unit Diagnostics section of the thermostat dealer control center on units installed with an S40 thermostat.
E 441	14	1 flash	4 flashes	Dealer Info Only	Compressor slowdown due to high compressor current. Compressor current is approaching limit. The compressor speed automatically slows. The control sets indoor CFM and outdoor RPM to values according to demand percentage rather than the actual Hz. Alarm is automatically cleared	This error code is primarily for informational purposes as the inverter controls the compressor to operate within design parameters. Alert code 441 typically occurs at startup as the compressor as the currently increases rapidly during startup. The inverter will reduce the compressor speed by 4 hz and slow the compressor ramp up speed to the requested compressor demand (capacity). This is normal and expected operation of the inverter to control the compressor within design parameters. In most cases the alert code 441 does not require any additional service or diagnostic procedures. E441 may also occur if the system is operating at high pressures.

TABLE 16. Outdoor Control 7-Segment Display Alert Codes - Compressor

System fault and lockout codes take precedence over system status codes (cooling, heating operating percentages or defrost/dehumidification). Only the latest active fault or lockout codes are displayed (if present). If no fault or lockout codes are active, then system status codes are displayed. Alert codes are also displayed on the S40 thermostat on systems installed with the S40 thermostat.

Alert Codes	Inverter Code	Inverter LED Flash Code (number of flashes)		Priority	Alarm Description	Possible Causes and Clearing Alarm
		Red LED	Green LED			
E 600	N/A	N/A	N/A	Service Urgent	Compressor has been cycled OFF by utility load-shedding function.	Load-shedding function: Provides a method for a local utility company to limit the maximum power level usage of the outdoor unit. The feature is activated by applying 24 volts AC power to the L and C terminals on the outdoor control.

Crankcase Heater, Checkout and Status / Error Codes

OPERATION:

CRANKCASE HEATER (HR1)

Compressors in all units are equipped with a 40 watt belly-band type crankcase heater. The heater prevents liquid from accumulating in the compressor. The heater is controlled by the crankcase heater thermostat.

CRANKCASE HEATER THERMOSTAT (S40)

Crankcase heater thermostat S40 controls the crankcase heater in all units and is located on the compressor shell.

1. When liquid line temperature drops below 50°F the thermostat closes which results in the heater being energized.
2. When liquid line temperature rises above 70°F the thermostat opens which results in the heater being de-energized.

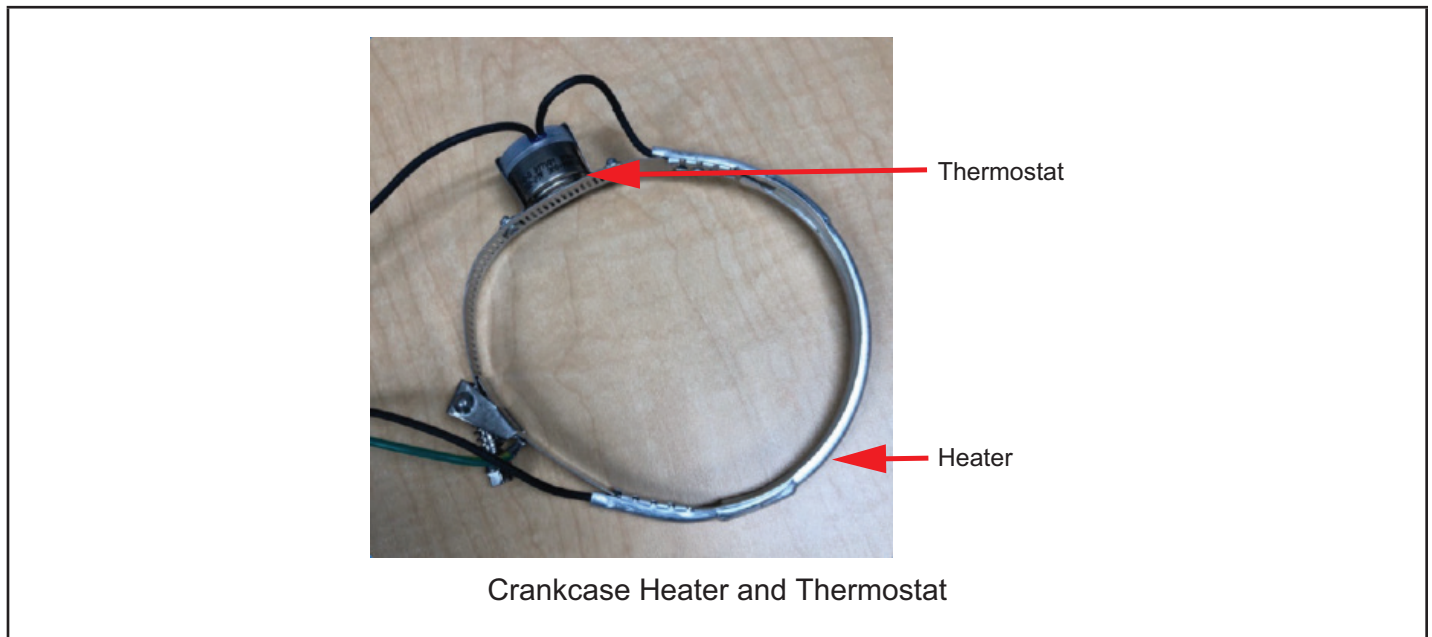

FIGURE 36. Belly-Band Crankcase Heater Thermostat

CHECKOUT:

Belly-Band Crankcase Heater: Using meter set on ohms, check crankcase heater resistance. If resistance is 0 ohms or infinite, replace the crankcase heater.

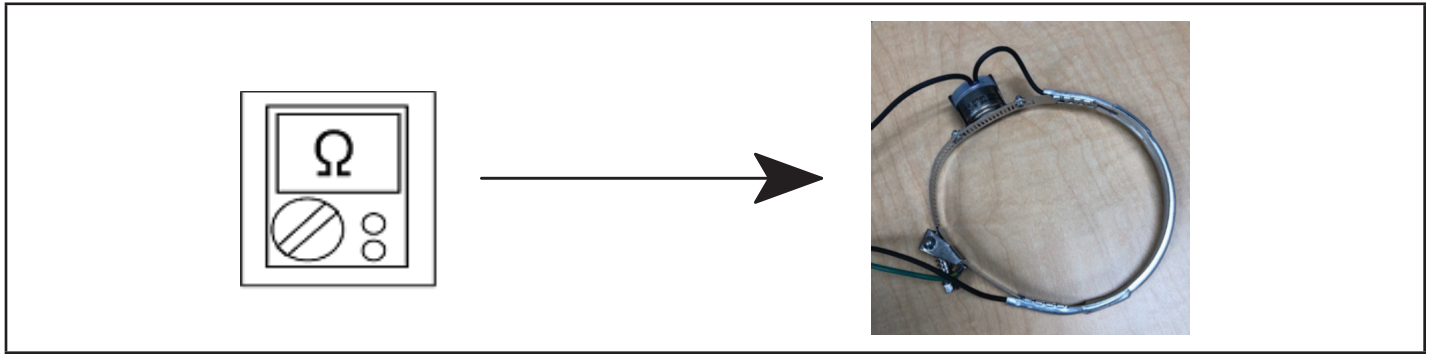

FIGURE 37. Checking Belly-Band Crankcase Heater

STATUS CODE:

None

ERROR CODES:

None

Compressor Sound Cover

All units come with a high-density sound cover. The cover helps to reduce any unwanted operating sounds from the compressor. The cover features a hook/loop closure system for ease of installation on the compressor.

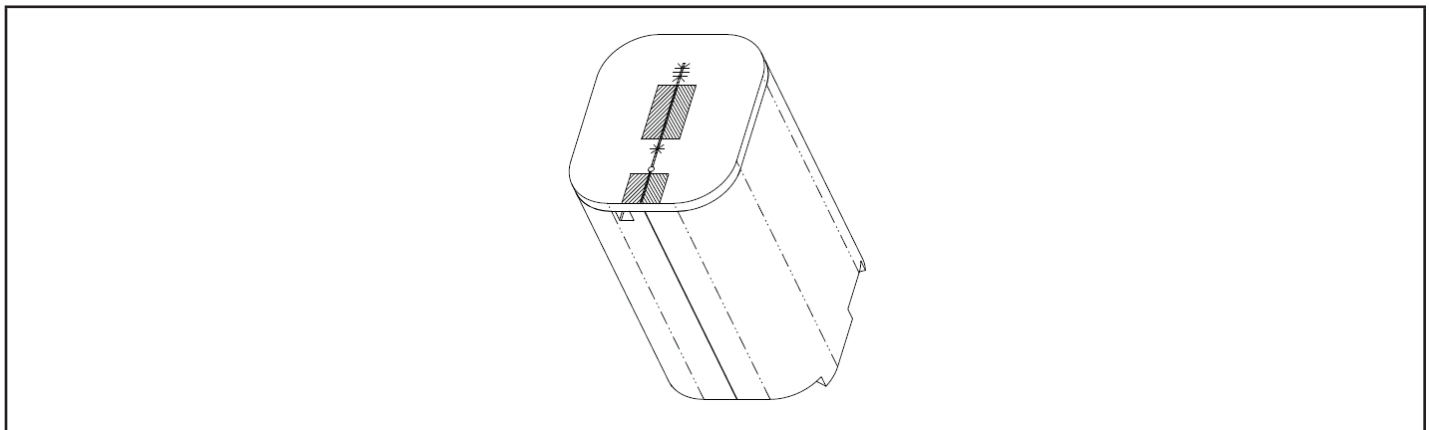

FIGURE 38. Compressor Sound Cover

Liquid Line Filter Drier

The SL22KLV units have a R-Scroll scroll compressor and have a bi-flow liquid line filter drier that is factory-installed in the liquid line. The filter drier is designed to remove moisture and foreign matter, which can lead to compressor failure.

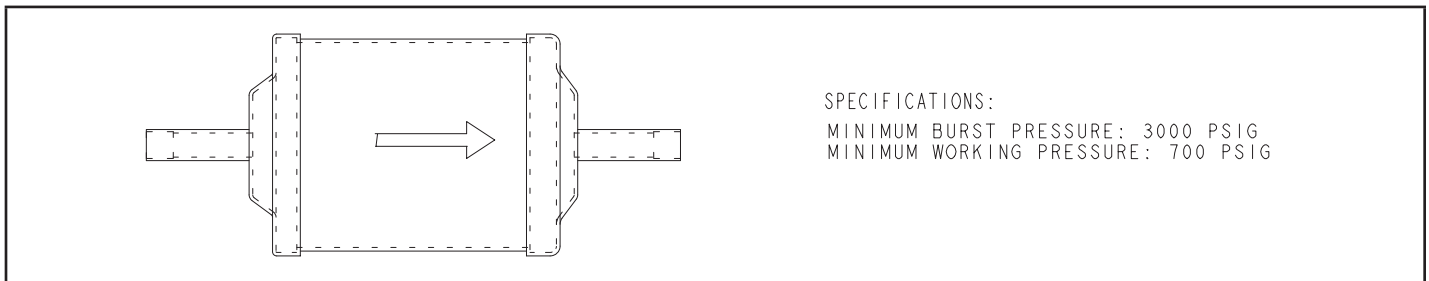

FIGURE 39. Liquid Line Filter Drier

Top Cap Switch Operation, Checkout and Status / Error Codes

OPERATION:

Top Cap Thermal Sensor Switch (S173)

Some units are equipped with a compressor-mounted normally closed temperature switch that prevents compressor damage due to overheating caused by internal friction. The switch is located on top of the compressor casing. This switch senses the compressor casing temperature and opens at 230-248°F to shut off compressor operation. The auto-reset switch closes when the compressor casing temperature falls to 149-185°F, and the compressor is re-energized. This is a single-pole, single-throw (SPST) bi-metallic switch.

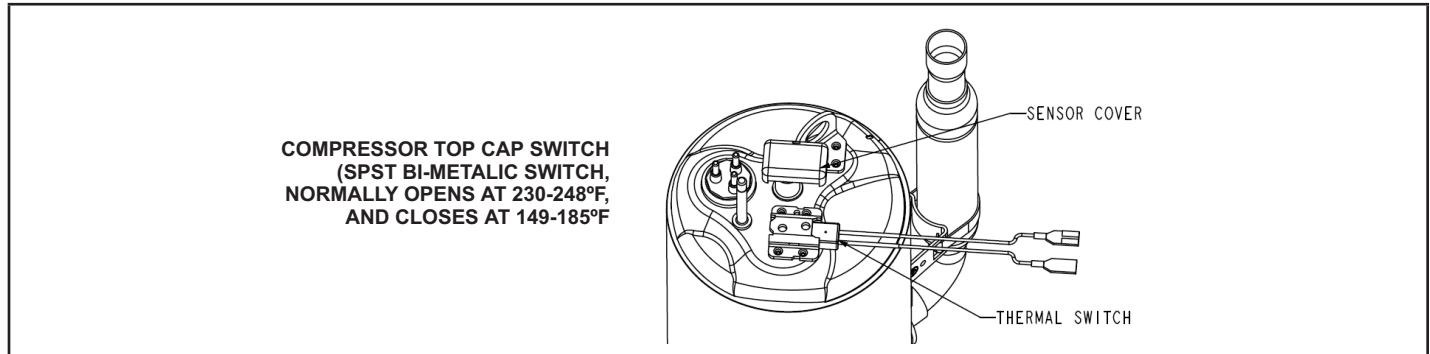

FIGURE 40. Top Cap Thermal Sensor Switch

CHECKOUT:

Using a multimeter set to ohms, with the terminals disconnected from the system, check the resistance between the two terminals of the top cap switch. If the meter display does not change, the switch is open. If the meter display goes to infinite, the switch is closed.

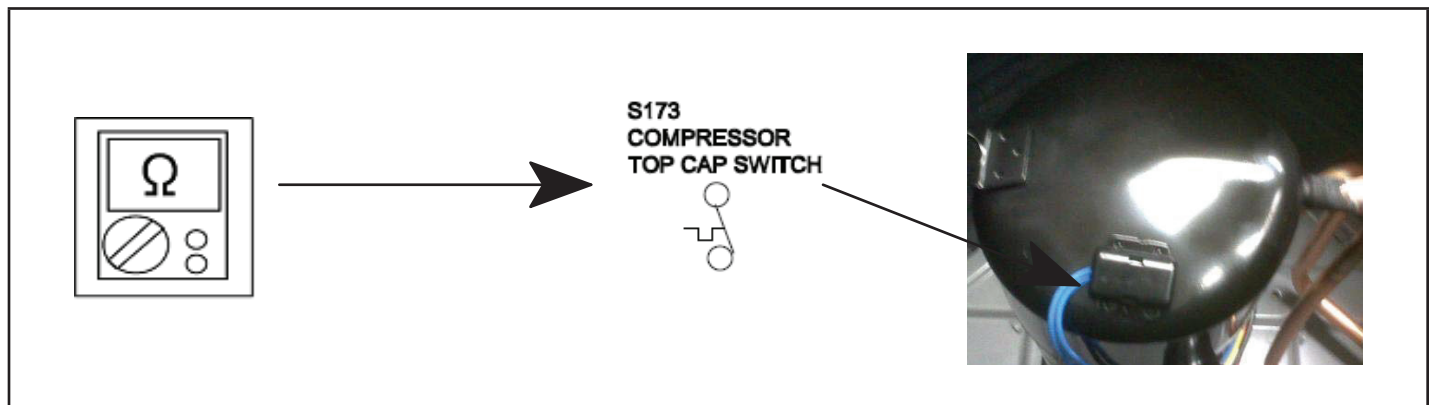

FIGURE 41. Verifying Top Cap Thermal Sensor Switch

STATUS:

None

ERROR:

TABLE 17. Outdoor Control 7-Segment Display Alert Codes - Top Cap Switch

NOTE - System fault and lockout codes take precedence over system status codes (cooling, heating operating percentages or de-frost/dehumidification). Only the latest active fault or lockout codes are displayed (if present). If no fault or lockout codes are active, then system status codes are displayed. Alert codes are also displayed on the communicating thermostat.

Alert Codes	Priority	Alarm Description	Possible Causes and Clearing Alarm
E 422	Service Soon	Compressor top cap switch exceeding thermal limit.	The top of the compressor is hot. Refrigerant charge may be low, or low mass flow of refrigerant. Check TXV, clogged filter drier, condenser fan motor, indoor blower motor, confirm indoor coil is clean. Check to make sure the blue wires from the top thermostat did not get pulled off one of the TP terminal on the outdoor control board.
E 442	Service Urgent	The top cap switch has opened 5 times within one hour. As a result, the outdoor unit is locked out.	When compressor thermal protection sensor opens 5 times within 1 hour, outdoor stops working. To clear, disconnect power to the indoor unit (24VAC power source to the outdoor control) which will power off the outdoor control and will open the outdoor unit contactor, which interrupts power to the inverter and then re-apply power.

Reactor Operations, Checkout and Status / Error Codes

OPERATION:

Reactor (Inductor or choke) is a passive two-terminal electrical component that stores energy in its magnetic field. Reactors are one of the basic components used in electronics where current and voltage change with time, due to the ability of inductors to delay and reshape alternating currents.

CHECKOUT:

Main Power ON – Voltage IN reactor should be the same as the voltage OUT. With main power OFF and reactor disconnected from system; resistance between leads should be the same

STATUS CODES:

None

ERROR CODES:

None

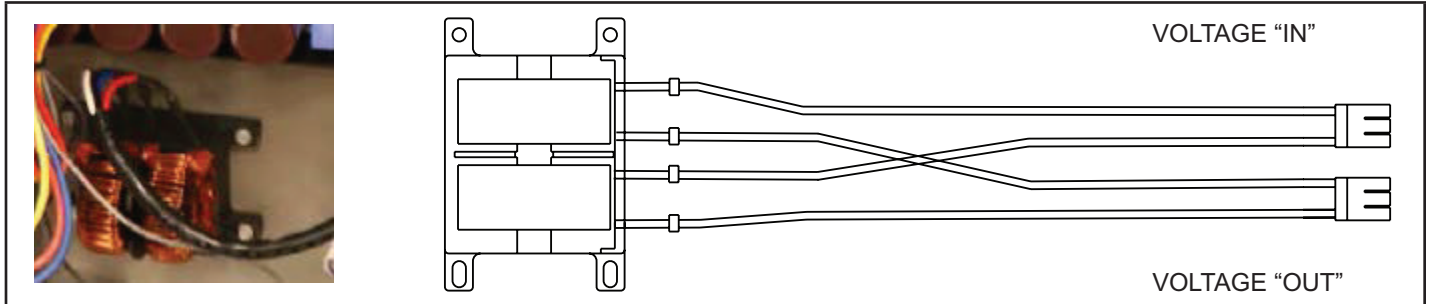

FIGURE 42. SL22KLV Reactor

Outdoor Fan Operation and Checkout

OPERATION:

The SL22KLV units have a variable speed ECM fan motor. The variable speed ECM fan motor is controlled by PWM fan output when the compressor is running and will vary the fan speed to match the compressor capacity.

LOW AMBIENT OPERATION:

The SL22KLV units have factory installed low ambient cooling mode operation that will control the condenser fan motor based upon liquid line temperature.

The SL22KLV units have a variable speed ECM fan motor. The outdoor control will begin to modulate the outdoor fan motor speed is below 65°F to maintain a liquid line sensor temperature between 58°F and 70°F. If the liquid line sensor drops below 55°F the control will cycle the fan off until liquid temperature rises above 58°F.

CHECKOUT:

VAC Voltage Check

Check for 208/240 VAC power at inverter contactor (red wires) (see figure 45).

Units with ECM Motor

1. With the unit running, check for 230VAC at the red outdoor fan motor wires at the contactor. If no voltage is present check main power at the contactor.
2. Perform a DC voltage check between the FPWM and Fan C terminal.
3. Using the push button on the control, enter the "fan test mode" in the "field test mode" by pushing and holding the button until solid "-" appears, release the button. Display will start flashing, within 10 seconds, push and hold the button until the "F" symbol displays then release the button. Display will begin to flash "F", within 10 seconds, push and hold the button until it stops flashing, release the button. Outdoor fan motor will cycle on for 10 minutes. To exit, push and hold the button until three horizontal bars display. Release the button and the outdoor fan will cycle off.

Outdoor Fan Motor Servicing



Servicing Fan without Removing Composite Top

To remove the fan motor assembly without removing the Composite top see steps below:

1. Turn off all power to the outdoor unit low and high voltage. Remove the Control Panel.
2. Disconnect compressor harness from plug.

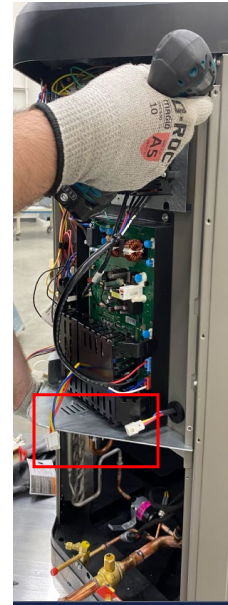

3. Remove (4) screws that secure the unit patch plate, remove patch plate and set to the side.

4. Remove (4) screws that secure the control panel to the corner posts. Drop the control panel approximately 2" and screw the bottom of control panel into the top holes for the patch plate.



5. Disconnect fan wires from control board, contactor, and fan ground wire. Slide the wires through the angled grommet.

6. Remove fan grille screws from the top panel. Motor/fan can now be serviced.

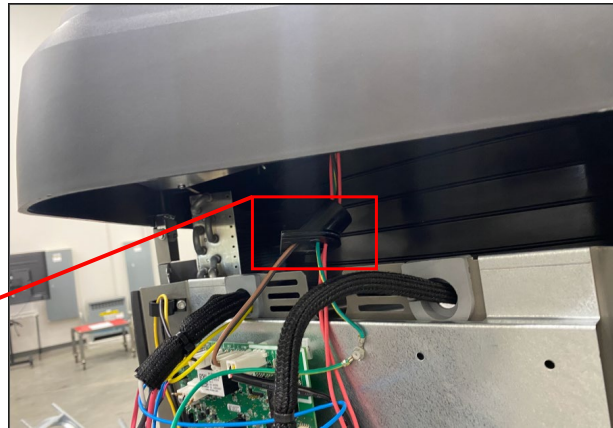

Reinstalling Fan Motor

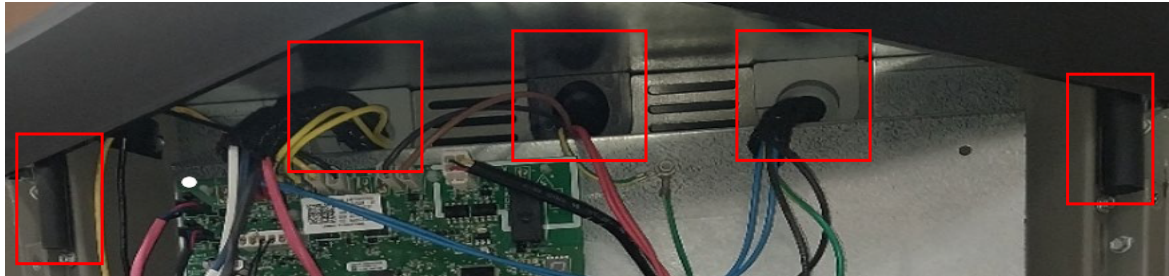

Reinstalling Fan Motor

1. Secure fan assembly back into the top panel using screws that were removed.
2. Route fan wires through the Angle grommet first.
3. Remove (2) screws from control panel and slide the control panel up. Slide all grommets and gaskets back into the top of the control panel. See red boxes above.
4. Once panel is lined up, secure into place with (4) screws.

5. Attach fan motor wires to contactor, control board and ground screw. Reattach compressor harness to the plug.

6. Reinstall patch plate at the bottom.

7. Check all wiring, then turn power back on and check fan motor operation.

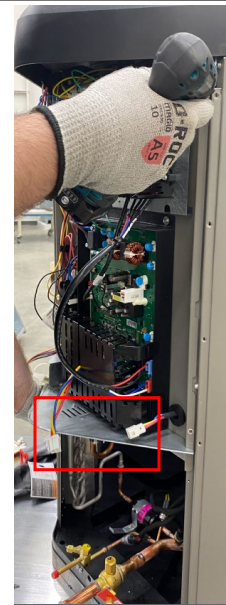

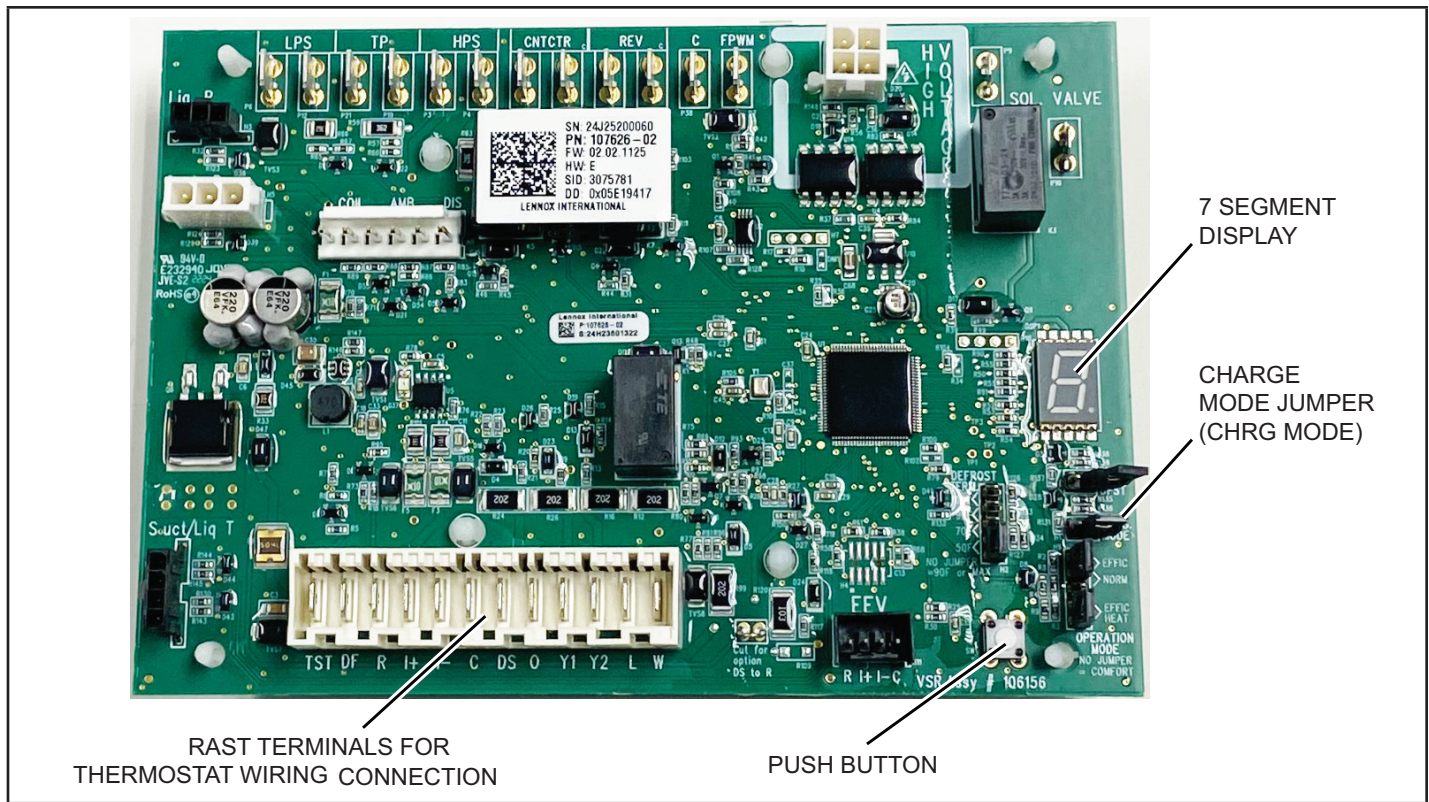

FIGURE 44. Outdoor Control Unit

STATUS CODES:

TABLE 18. Outdoor Control 7-Segment Display Alert Codes - Outdoor Control Status			
<i>NOTE - System fault and lockout codes take precedence over system status codes (cooling, heating operating percentages or defrost/dehumidification). Only the latest active fault or lockout codes are displayed (if present). If no fault or lockout codes are active, then system status codes are displayed. Alert codes are also displayed on the S40 thermostat.</i>			
Alert Codes	Priority	Alarm Description	Possible Causes and Clearing Alarm
E 600	Service Urgent	Compressor has been cycled OFF on utility load shedding	Load shedding function: Provides a method for a local utility company to limit the maximum power level usage of the outdoor unit. The feature is activated by applying 24 volts AC power to the L and C terminals on the outdoor control.
E 601	Service Urgent	Outdoor unit has been cycled OFF on low temperature protection (-20°F).	Low temperature Protection: Unit will operate down to -20°F. Unit will cycle off at temperatures below -20°F. Unit restarts when ambient reaches -15°F or higher.

System Configuration

SL22KLV Thermostat Control

The SL22KLV variable capacity units are a fully communicating system and must be installed with an S40 thermostat and a communicating indoor unit.

S40 Communicating Thermostat Control

The SL22KLV variable capacity unit must be installed as a fully communicating system consisting of S40 Smart Wi-Fi Communicating Thermostat, a communicating indoor unit and the SL22KLV variable capacity outdoor unit wired with (4) communication wires (R, I+, I-, and C) connected to the SL22KLV Outdoor Unitary Control.

The SL22KLV variable capacity unit when wired as a fully communicating system will take full advantage of the advanced diagnostics and control, Wi-Fi accessibility and system operation parameters. Refer to the SL22KLV field wiring diagram for an S40 communicating thermostat.

Unit Operation

SL22KLV Unit Operation with an S40 Communicating Thermostat

The SL22KLV unit must be installed with an S40 communicating thermostat and communicating indoor unit. The unit capacity will be controlled in the variable capacity mode throughout the range of capacity from minimum capacity to maximum capacity based upon thermostat demand in both the cooling and heat pump heating mode. The indoor air volume will be controlled to match compressor capacity throughout the capacity range.

Heat Pump Heating Mode

Extended Heat Pump Heating Performance.

The SL22KLV provides extended heating performance in the heat pump heating mode compared to a traditional air source heat pump. The SL22KLV will begin to increase the compressor speed during a 100% heat pump demand at an outdoor temperature of 47°F and will reach the maximum compressor speed at an outdoor temperature of 6°F to -10°F, depending on the model. The increase in compressor speed will increase the heat pump heating capacity at the lower outdoor temperatures. The increase in heat pump heating capacity will significantly reduce the need for auxiliary heat and will reduce the operating cost of the system. The table below and provides a summary of the SL22KLV heat pump heating performance. The SL22KLV-036 heating performance curve compares the SL22KLV heating performance to a traditional variable capacity heat pump and illustrates the benefit of the extended heating performance.

SL22KLV Heating Performance Summary

Model	AHRI Maximum Heating Capacity at 47°F Outdoor Temperature	AHRI Maximum Heating Capacity at 17°F Outdoor Temperature	Percentage of Heating Capacity at 17°F Compared to Capacity at 47°F
SL22KLV-024 w/ CBK48MVT-030	22,200 Btuh	25,200 Btuh	113%
SL22KLV-036 w/ CBK48MVT-036	36,000 Btuh	34,000 Btuh	94%
SL22KLV-048 w/ CBK48MVT-048	46,000 Btuh	45,500 Btuh	98%
SL22KLV-060 w/ CBK48MVT-060	60,000 Btuh	45,000 Btuh	75%

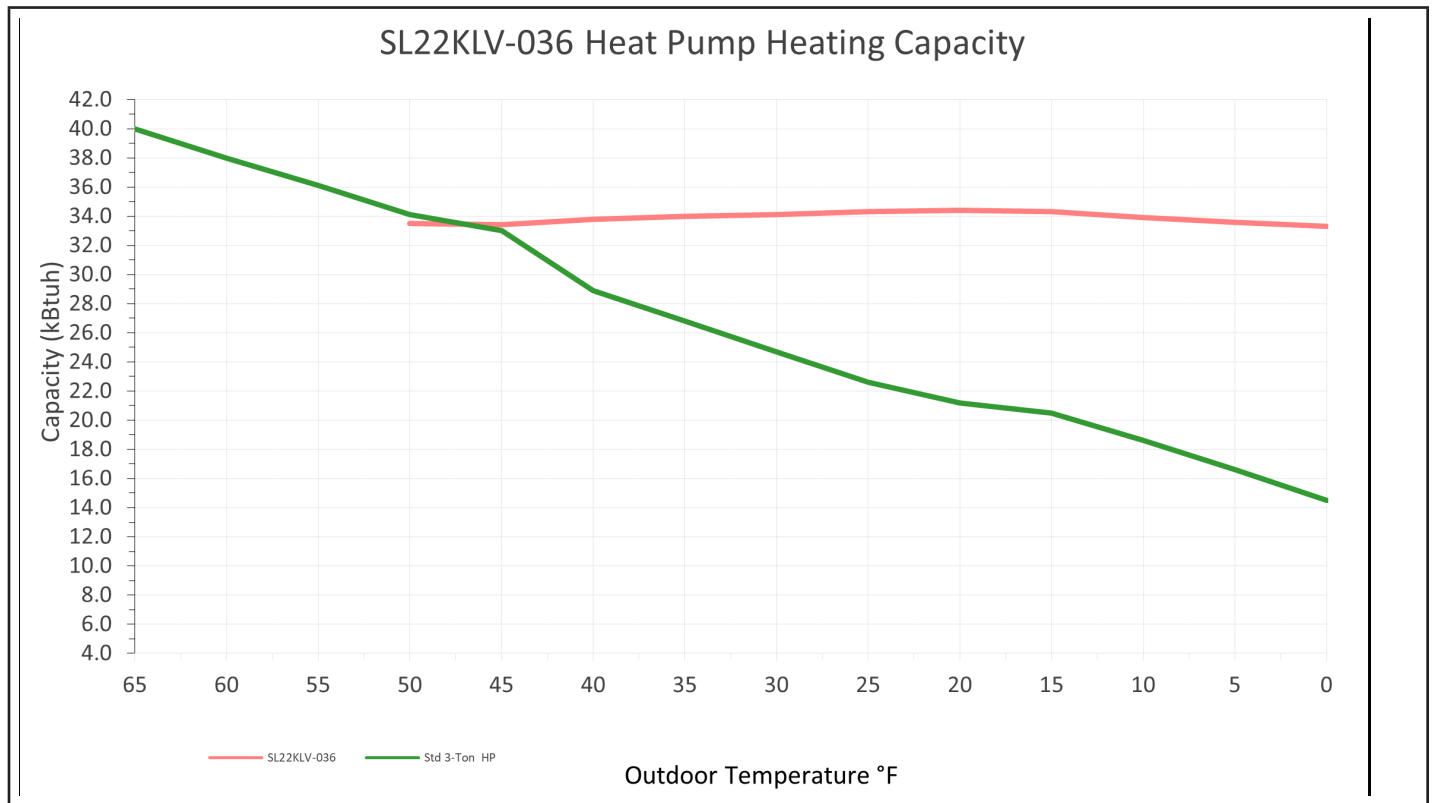

SL22KLV Heating Performance Curve

Emergency 24VAC System Operation

Emergency 24VAC Operation with Conventional 24VAC Thermostat

The SL22KLV variable capacity heat pump Emergency Operation will operate as single-stage unit at 100% capacity using a 24VAC input. The Emergency Operation is accomplished by providing (4) 24VAC wires (R, C, Y1 and O) to the heat pump. The thermostat used for Emergency Operation requires a single-stage heat pump thermostat.

When Emergency Operation is initiated, the blower air volume must be checked to verify blower operation at full air volume during a cooling demand or heat pump demand. Adjustments to the blower air volume settings can be made using the indoor blower speed DIP switches or jumpers on the indoor unit iComfort control. The Emergency 24VAC thermostat operation wiring detail is provided below.

NOTES:

- 1 – For Emergency 24VAC thermostat operation, install 24VAC conventional single stage heat pump thermostat. Wire the emergency thermostat as shown on the Emergency 24VAC wiring diagram. The outdoor unit will operate at 100% output in this configuration.
- 2 – For Emergency 24 VAC thermostat operation, make the following outdoor unit wiring changes. Move the wire on both indoor and outdoor controls from terminals i+ to Y1. On heat pumps move the wire from i- to O on both the indoor and outdoor control.

Emergency 24VAC Thermostat Operation (Non-Communicating Mode)

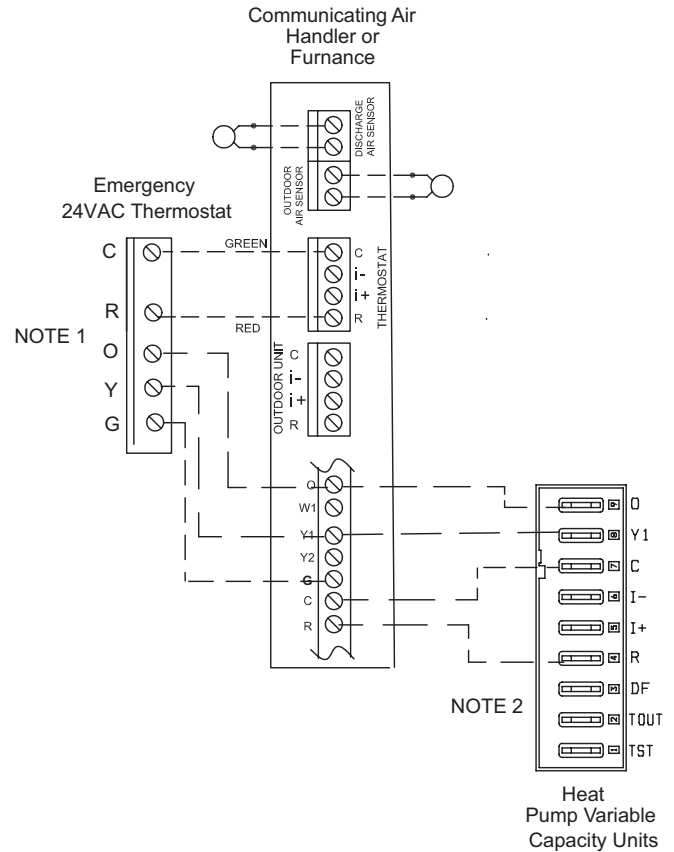

ERROR CODES:

TABLE 19. Outdoor Control 7-Segment Display Alert Codes - Outdoor Control Errors

NOTE - System fault and lockout codes take precedence over system status codes (cooling, heating operating percentages or defrost/dehumidification). Only the latest active fault or lockout codes are displayed (if present). If no fault or lockout codes are active, then system status codes are displayed. Alert codes are also displayed on the S40 thermostat.

Alert Codes	Priority	Alarm Description	Possible Causes and Clearing Alarm
E 105	Service Soon	The outdoor control has lost communication with either the thermostat or indoor unit.	Equipment is unable to communicate. Indicates numerous message errors. In most cases errors are related to electrical noise. Make sure high voltage power is separated from RSBus. Check for miswired and/or loose connections between the stat, indoor unit and outdoor unit. Check for a high voltage source of noise close to the system. Fault clears after communication is restored.
E 120	Service Soon	There is a delay in the outdoor unit responding to the system.	Typically, this alarm/code does not cause any issues and will clear on its own. The alarm / code is usually caused by a delay in the outdoor unit responding to the thermostat. Check all wiring connections. Cleared after unresponsive device responds to any inquiry.
E 124	Service Urgent	The S40 thermostat has lost communication with the outdoor unit for more than 3 minutes.	Equipment lost communication with the thermostat. Check the wiring connections, ohm wires and cycle power. The alarm stops all associated HVAC operations and waits for a heartbeat message from the unit that's not communicating. The alarm / fault clears after communication is re-established.
E 125	Service Urgent	There is a hardware problem with the outdoor control.	There is a control hardware problem. Replace the outdoor control if the problem prevents operation and is persistent. The alarm / fault is cleared 300 seconds after the fault recovers
E 131	Service Urgent	The outdoor unit control parameters are corrupted	Reconfigure the system. Replace the control if heating or cooling is not available.
E 132	Service Urgent	Internal software error	Replace outdoor control.

Unit Sensor Operation, Checkout and Status /Error Codes

OPERATION:

6-Pin Sensor Harness (COIL, AMB, LIQ/DIS)

Dis Sensor (RT61)

The compressor discharge line sensor is located on positions 1 and 2 of the connector. The discharge line sensor is location on the compressor discharge line several inches from the compressor. The unitary control will reduce the compressor speed if the discharge line temperature begins to increase above 220°F.

Ambient Temperature Sensor (RT13)

Ambient temperatures, as read by the ambient temperature sensor connected to pin 3 and pin 4, which are below -35°F (-37°C) or above 120°F (48°C) trigger a fault condition. If the ambient sensor is open, shorted, or out of the temperature range of the sensor, the control displays the appropriate alert code. Heating and cooling operation is allowed in this fault condition

Coil Temperature Sensor (RT21)

The liquid temperature sensor located on the outlet of the outdoor TXV is connected to pins 5 and 6.

6-Pin Suction Temperature Sensor / Liquid Temperature Sensor Harness

Suction Line Sensor (RT41)

Suction line temperature is read by the suction line temperature sensor between Pins 1 and Pin 2 of the 6-pin sensor harness. Nominal Resistance of the sensor is 10K ohms at 77F. The control will display the E182 error code if the sensor reads open or shorted for 24 hours. Cooling operation is allowed with this fault.

Liquid Line Temperature Sensor (RT36)

Liquid line temperature is read by the liquid line temperature sensor between Pins 3 and Pin 4 of the 6-pin sensor harness. Nominal Resistance of the sensor is 10K ohms at 77F. The control will display the E184 error code if the sensor reads open or shorted for 24 hours. Cooling operation is allowed with this fault.

SENSOR	TEMP RANGE °F (°C)	RESISTANCE VALUES RANGE (OHMS)	PIN# / WIRE SLEEVE COLOR
COIL	-40 (-40) TO 140 (60)	336,000 to 2,487 (see table 17 on page 77 for exact temperature to ohm readings)	6 AND 5 (BROWN)
OUTDOOR AMBIENT	-40 (-40) TO 140 (60)	336,000 to 2,487 (see table 17 on page 77 for exact temperature to ohm readings)	4 AND 3 (BLACK)
DISCHARGE	0°F to 250°F	85,407 ohms to 378 ohms	2 AND 1

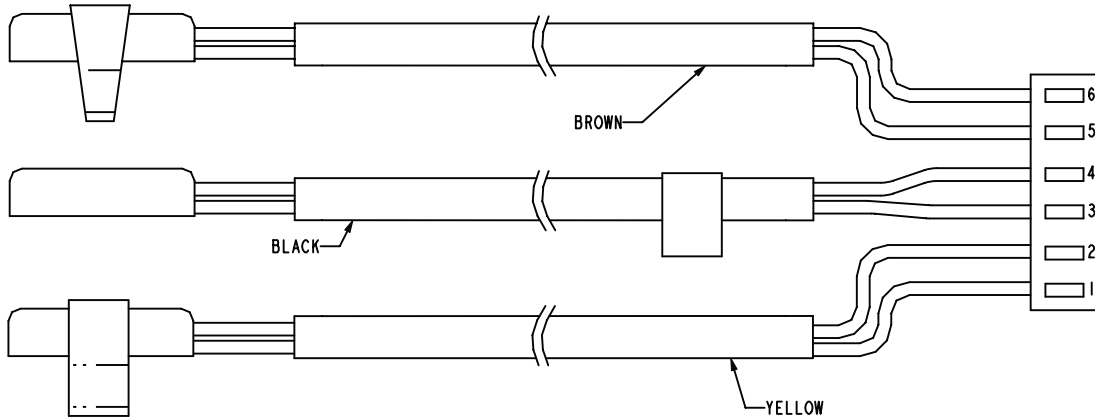

FIGURE 45. Temperature Sensor Specification

CHECKOUT:

Sensors connect to the outdoor control through a field-replaceable harness assembly that plugs into the outdoor control. Through the sensors, the control detects outdoor ambient, coil and liquid temperature fault conditions. As the detected temperature changes, the resistance across the sensor changes. Check sensor operation by reading ohms across pins shown in figure 45.

NOTE – When checking the ohms across a sensor, be aware that a sensor showing a resistance value that is not within the range shown in figure 45, may be performing as designed. However, if a shorted or open circuit is detected, then the sensor may be faulty and the sensor harness will need to be replaced.

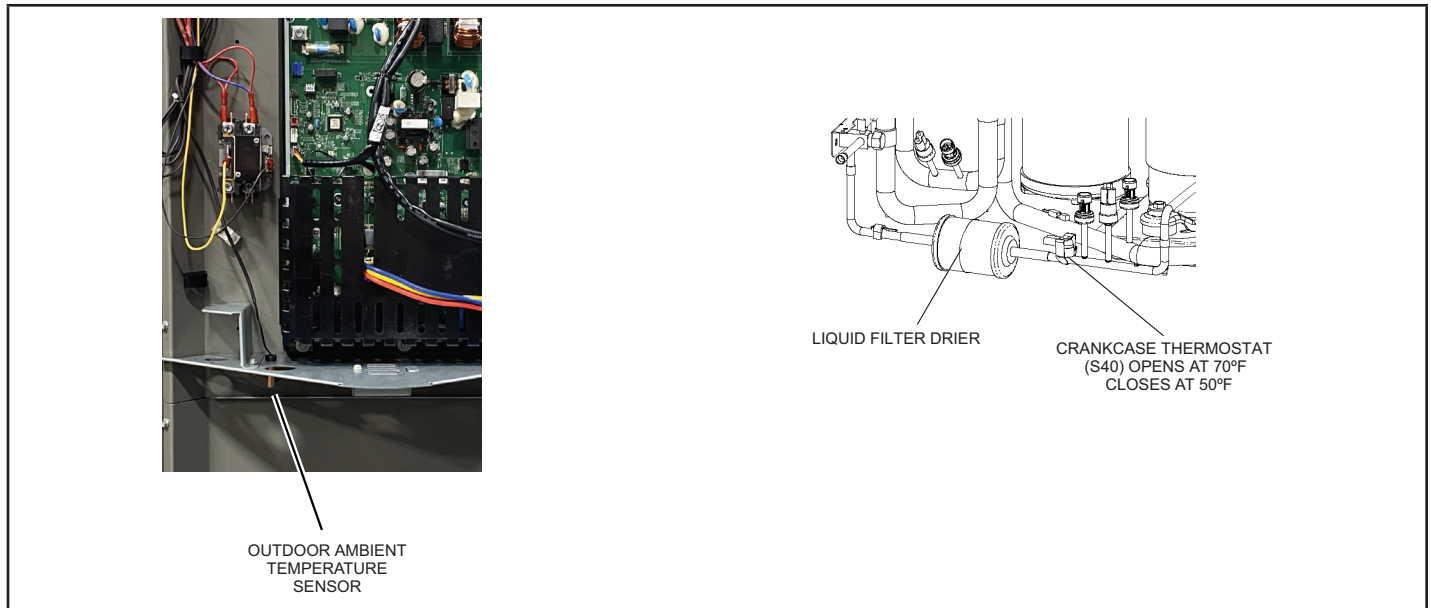

FIGURE 46. Temperature Sensor Locations

TABLE 20. Ambient and Liquid Line Sensors Temperature / Resistance Range

F°	Resistance	F°	Resistance	F°	Resistance	F°	Resistance
136.3	2680	56.8	16657	21.6	44154	-11.3	123152
133.1	2859	56.0	16973	21.0	44851	-11.9	125787
130.1	3040	55.3	17293	20.5	45560	-12.6	128508
127.3	3223	54.6	17616	20.0	46281	-13.2	131320
124.7	3407	53.9	17942	19.4	47014	-13.9	134227
122.1	3592	53.2	18273	18.9	47759	-14.5	137234
119.7	3779	52.5	18607	18.4	48517	-15.2	140347
117.5	3968	51.9	18945	17.8	49289	-15.9	143571
115.3	4159	51.2	19287	17.3	50074	-16.5	146913
113.2	4351	50.5	19633	16.8	50873	-17.2	150378
111.2	4544	49.9	19982	16.3	51686	-17.9	153974
109.3	4740	49.2	20336	15.7	52514	-18.6	157708
107.4	4937	48.5	20695	15.2	53356	-19.3	161588
105.6	5136	47.9	21057	14.7	54215	-20.1	165624
103.9	5336	47.3	21424	14.1	55089	-20.8	169824
102.3	5539	46.6	21795	13.6	55979	-21.5	174200
100.6	5743	46.0	22171	13.1	56887	-22.3	178762
99.1	5949	45.4	22551	12.5	57811	-23.0	183522
97.6	6157	44.7	22936	12.0	58754	-23.8	188493
96.1	6367	44.1	23326	11.5	59715	-24.6	193691
94.7	6578	43.5	23720	11.0	60694	-25.4	199130
93.3	6792	42.9	24120	10.4	61693	-26.2	204829
92.0	7007	42.3	24525	9.9	62712	-27.0	210805
90.6	7225	41.7	24934	9.3	63752	-27.8	217080
89.4	7444	41.1	25349	8.8	64812	-28.7	223677
88.1	7666	40.5	25769	8.3	65895	-29.5	230621
86.9	7890	39.9	26195	7.7	67000	-30.4	237941
85.7	8115	39.3	26626	7.2	68128	-31.3	245667
84.5	8343	38.7	27063	6.7	69281	-32.2	253834
83.4	8573	38.1	27505	6.1	70458	-33.2	262482
82.3	8806	37.5	27954	5.6	71661	-34.1	271655
81.2	9040	37.0	28408	5.0	72890	-35.1	281400
80.1	9277	36.4	28868	4.5	74147	-36.1	291774
79.0	9516	35.8	29335	3.9	75431	-37.1	302840
78.0	9757	35.2	29808	3.4	76745	-38.2	314669
77.0	10001	34.7	30288	2.8	78090	-39.2	327343
76.0	10247	34.1	30774	2.3	79465	---	---
75.0	10496	33.5	31267	1.7	80873	---	---
74.1	10747	33.0	31766	1.2	82314	---	---
73.1	11000	32.4	32273	0.6	83790	---	---
72.2	11256	31.9	32787	0.0	85302	---	---
71.3	11515	31.3	33309	-0.5	86852	---	---
70.4	11776	30.7	33837	-1.1	88440	---	---
69.5	12040	30.2	34374	-1.7	90068	---	---
68.6	12306	29.6	34918	-2.2	91738	---	---
67.7	12575	29.1	35471	-2.8	93452	---	---
66.9	12847	28.6	36031	-3.4	95211	---	---
66.0	13122	28.0	36600	-4.0	97016	---	---
65.2	13400	27.5	37177	-4.6	98870	---	---
64.4	13681	26.9	37764	-5.2	100775	---	---
63.6	13964	26.4	38359	-5.7	102733	---	---
62.8	14251	25.8	38963	-6.3	104746	---	---
62.0	14540	25.3	39577	-6.9	106817	---	---
61.2	14833	24.8	40200	-7.5	108948	---	---
60.5	15129	24.2	40833	-8.2	111141	---	---
59.7	15428	23.7	41476	-8.8	113400	---	---
59.0	15730	23.2	42130	-9.4	115727	---	---
58.2	16036	22.6	42794	-10.0	118126	---	---
57.5	16345	22.1	43468	-10.6	120600	---	---

Discharge Line Sensor Temperature Resistance Table

°F	Resis. Ohms	°F	Resis. Ohms	°F	Resis. Ohms	°F	Resis. Ohms	°F	Resis. Ohms
0	85,407	51	19378	101	5697	151	2003	201	814
1	82,739	52	18871	102	5570	152	1965	202	800
2	80,163	53	18378	103	5447	153	1927	203	787
3	77,677	54	17900	104	5326	154	1891	204	774
4	75,276	55	17437	105	5209	155	1855	205	761
5	72,957	56	16986	106	5094	156	1820	206	749
6	70,718	57	16549	107	4982	157	1785	207	736
7	68,555	58	16124	108	4873	158	1752	208	724
8	66,466	59	15712	109	4767	159	1719	209	712
9	64,447	60	15311	110	4664	160	1687	210	701
10	62,497	61	14923	111	4563	161	1655	211	690
11	60,613	62	14545	112	4464	162	1624	212	678
12	58,791	63	14178	113	4368	163	1594	213	667
13	57,031	64	13821	114	4274	164	1565	214	657
14	55,329	65	13475	115	4183	165	1536	215	646
15	53,684	66	13138	116	4094	166	1508	216	636
16	52,093	67	12811	117	4007	167	1480	217	626
17	50,555	68	12493	118	3922	168	1453	218	616
18	49,067	69	12183	119	3839	169	1427	219	606
19	47,628	70	11883	120	3758	170	1401	220	597
20	46,236	71	11591	121	3679	171	1376	221	587
21	44,890	72	11307	122	3602	172	1351	222	578
22	43,587	73	11031	123	3527	173	1327	223	569
23	42,327	74	10762	124	3453	174	1303	224	560
24	41,107	75	10501	125	3382	175	1280	225	551
25	39,926	76	10247	126	3312	176	1257	226	543
26	38,783	77	10000	127	3244	177	1234	227	534
27	37,677	78	9760	128	3177	178	1212	228	526
28	36,606	79	9526	129	3112	179	1191	229	518
29	35,569	80	9299	130	3048	180	1170	230	510
30	34,565	81	9077	131	2986	181	1149	231	502
31	33,592	82	8862	132	2925	182	1129	232	495
32	32,650	83	8652	133	2866	183	1109	233	487
33	31,738	84	8448	134	2808	184	1090	234	480
34	30,855	85	8250	135	2752	185	1071	235	473
35	29,999	86	8057	136	2696	186	1052	236	465
36	29,170	87	7869	137	2642	187	1034	237	458
37	28,366	88	7685	138	2590	188	1016	238	452
38	27,588	89	7507	139	2538	189	999	239	445
39	26,833	90	7334	140	2488	190	982	240	438
40	26,101	91	7165	141	2439	191	965	241	432
41	25,392	92	7000	142	2390	192	948	242	425
42	24,705	93	6840	143	2343	193	932	243	419
43	24,038	94	6683	144	2297	194	916	244	413
44	23,392	95	6531	145	2253	195	901	245	407
45	22,765	96	6383	146	2209	196	885	246	401
46	22,156	97	6239	147	2166	197	871	247	395
47	21,567	98	6098	148	2124	198	856	248	389
48	20,994	99	5961	149	2083	199	842	249	384
49	20,439	100	5827	150	2043	200	827	250	378
50	19,901	---	---	---	---	---	---	---	---

ERROR CODES:

TABLE 21. Outdoor Control 7-Segment Display Alert Codes – Outdoor Control Errors

NOTE - System fault and lockout codes take precedence over system status codes (cooling, heating operating percentages or defrost/dehumidification). Only the latest active fault or lockout codes are displayed (if present). If no fault or lockout codes are active, then system status codes are displayed. Alert codes are also displayed on the S40 thermostat.

Alert Codes	Priority	Alarm Description	Possible Causes and Clearing Alarm
E 180	Service Soon/ Service Critical	The S40 thermostat has found a problem with the outdoor unit's ambient temperature sensor.	During normal operation, after the outdoor control recognizes sensors, the alarm will be sent only if valid temperature reading is lost. Compare outdoor sensor resistance to temperature/resistance charts in unit installation instructions. Replace sensor pack if necessary. At the beginning of (any) configuration, furnace or air-handler control will detect the presence of the sensor(s). If detected (reading in range), appropriate feature will be set as 'installed' and shown in the S40 thermostat 'About' screen. The alarm / fault will clear upon configuration, or sensing normal values.
E 182	Service Soon	Suction Temperature Sensor has malfunctioned	Sensor is open or shorted. Replace the Sensor
E 183	Service Soon	Liquid Pressure Transducer Fault	Liquid pressure transducer is out of range. The signal should be between 0.5 VDC and 4.5 VDC between Blue and Black. The error code will be cleared when the proper signal is provided. Systems controlled by a conventional 24VAC heat pump thermostat will operate in stage mode.
E 184	Service Soon	Faulty outdoor liquid line sensor	Sensor is open or shorted. Replace the sensor.
E 186	Service Soon	Discharge temperature too low	Discharge temperature reading too low. Heat pump heating operation can continue. Check discharge temperature sensor location and verify the sensor is secure on the discharge line.
E 187	Service Soon/ Service Critical	Discharge temperature/pressure too high	Discharge temperature or pressure ratio exceeded upper limit. Heat pump heating stopped.

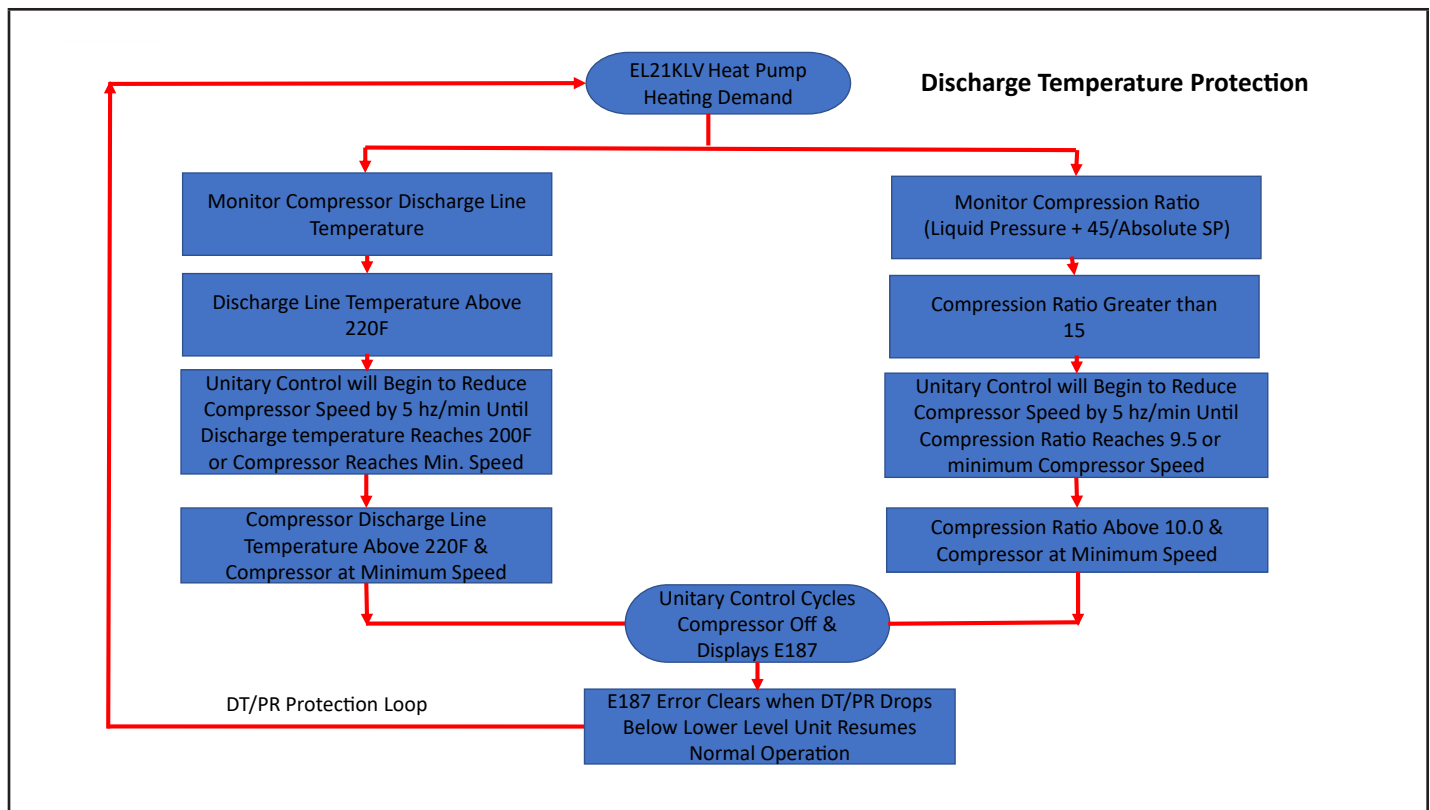

FIGURE 47

DC Inverter Control Operation, Checkout, Status / Error Codes

OPERATION OF COMPONENTS:

Electromagnetic compatibility circuit (EMC): EMC ensures the correct operation of different equipment items which use or respond to electromagnetic phenomena. It also helps to negate the effects of interference.

CONVERTER:

Converts AC (alternating current) to DC (direct current).

POWER FACTOR CORRECTION (PFC) CIRCUIT:

The PFC module is an integrated part of the outdoor inverter that monitors the DC bus for high, low and abnormal voltage conditions. If any of these conditions are detected, the PFC function and compressor will stop.

INTELLIGENT (INVERTER) POWER MODULE (IPM):

The IPM converts DC power into AC power. The control method is known as pulse width modulation (PWM). This means the DC is switched on and off very quickly (chopped) by the transistor switches to make simulated AC at required frequency and voltage.

COMMUNICATION CONTROL CIRCUIT:

Receives and sends message between the inverter and the outdoor control.

STATUS CODES:

TABLE 22. Outdoor Control 7-Segment Display Alert Codes and Inverter LED Flash Codes					
<i>NOTE - System fault and lockout codes take precedence over system status codes (cooling, heating operating percentages or defrost/dehumidification). Only the latest active fault or lockout codes are displayed (if present). If no fault or lockout codes are active, then system status codes are displayed. Alert codes are also displayed on the S40 thermostat.</i>					
Alert Codes	Inverter LED Flash Code (number of flashes)		Priority	Alarm Description	Possible Causes and Clearing Alarm
	Red LED	Green LED			
N/A	ON	OFF	N/A	SL22KLV-024 only: Indicates inverter is operating normally.	
N/A	ON	ON	N/A	SL22KLV-036, -048, -060 only: Indicates inverter is operating normally.	
N/A	OFF	OFF	N/A	Indicates inverter is NOT energized.	

ERROR CODES:

TABLE 23. Outdoor Control 7-Segment Display Alert Codes and Inverter LED Flash Codes						
<i>NOTE - System fault and lockout codes take precedence over system status codes (cooling, heating operating percentages or defrost/dehumidification). Only the latest active fault or lockout codes are displayed (if present). If no fault or lockout codes are active, then system status codes are displayed. Alert codes are also displayed on the S40 thermostat.</i>						
Alert Codes	Inverter Code	Inverter LED Flash Code (number of flashes)		Priority	Alarm Description	Possible Causes and Clearing Alarm
		Red LED	Green LED			
E 423	40	4 flashes	OFF	Service Soon/Service Critical	The inverter has detected a circuit problem.	Control will lock out after 10 strikes within an hour. To clear, disconnect power to the indoor unit (24VAC power source to the outdoor control) which will power off the outdoor control and will open the outdoor unit contactor, which interrupts power to the inverter and then re-apply power.
E 427	21	2 flashes	1 flash	Service Soon/Service Critical	The inverter has detected a DC peak fault condition.	If condition (55A or higher) is detected, outdoor unit will stop (compressor and fan). Antishort cycle is initiated. If peak current (55A or higher) occurs 10 times within an hour, system will lock out. Indicates high pressure, condenser fan failure, locked compressor rotor or overcharge. To clear, disconnect power to the indoor unit (24VAC power source to the outdoor control) which will power off the outdoor control and will open the outdoor unit contactor, which interrupts power to the inverter and then re-apply power.

TABLE 23. Outdoor Control 7-Segment Display Alert Codes and Inverter LED Flash Codes

NOTE - System fault and lockout codes take precedence over system status codes (cooling, heating operating percentages or defrost/dehumidification). Only the latest active fault or lockout codes are displayed (if present). If no fault or lockout codes are active, then system status codes are displayed. Alert codes are also displayed on the S40 thermostat.

Alert Codes	Inverter Code	Inverter LED Flash Code (number of flashes)		Priority	Alarm Description	Possible Causes and Clearing Alarm
		Red LED	Green LED			
E 428	22	2 flashes	2 flashes	Service Soon/ Service Critical	The inverter has detected a high main input current condition	If condition is detected, outdoor unit will stop (compressor and fan). Antishort cycle is initiated. If condition occurs 5 times within an hour, the unitary control will cycle the contactor to prevent the unit from locking out. Indicates high pressure, condenser fan failure or overcharge. To clear, disconnect power to the indoor unit (24VAC power source to the outdoor control) which will power off the outdoor control and will open the outdoor unit contactor, which interrupts power to the inverter and then re-apply power.
E 429	23	2 flashes	3 flashes	Service Soon/ Service Critical	On a call for compressor operation, if DC link power in inverter does not rise above 180 VDC for 2 and 3 ton models, 250 VDC for 4 and 5 ton models, within 30 seconds, the control will display a moderate code. If condition is detected, outdoor unit will stop (Compressor and fan). Antishort cycles is initiated. If condition occurs 10 times within a 60 minute rolling time period, system will lock out and display a critical code.	Issues: (1) If DC link power in inverter does not rise above 180 VDC for 2- and 3-ton models, 250 VDC for 4- and 5-ton models, within 30 seconds, the outdoor control will display a moderate code. (2) Capacitors on inverter do not properly charge. Corrective Actions: (1) Check for proper main power to outdoor unit and for any loose electrical connections.
E 430	26	2 flashes	6 flashes	Service Soon/ Service Critical	Compressor start failure.	If condition is detected, outdoor unit will stop (compressor and fan). Antishort cycle is initiated. If condition occurs 10 times within an hour, system will lock out. Indicates poor connection at compressor harness, improper winding resistance, locked compressor rotor, or flooded compressor. To clear, disconnect power to the indoor unit (24VAC power source to the outdoor control) which will power off the outdoor control and will open the outdoor unit contactor, which interrupts power to the inverter and then re-apply power.
E 431	27	2 flashes	7 flashes	Service Soon/ Service Critical	Error occurs when PFC detects an over-current condition of 100A, the control will display a moderate code. If condition is detected, outdoor unit will stop (Compressor and fan). Anti-short cycle is initiated. Inverter is unavailable to communicate with the outdoor control for 3 minutes. If condition occurs 10 times within a 60 minute rolling time period, system will lock out and display a critical code.	Issues: (1) Indicates power interruption, brownout, poor electrical connection or loose inverter input wire. (2) System testing was set up and code was generated when the reversing valve is de-energized coming out of defrost (code appears with or without 30 compressor delay). Corrective Actions: (1) Check for proper main power to outdoor unit and for any loose electrical connections.

TABLE 23. Outdoor Control 7-Segment Display Alert Codes and Inverter LED Flash Codes

NOTE - System fault and lockout codes take precedence over system status codes (cooling, heating operating percentages or defrost/dehumidification). Only the latest active fault or lockout codes are displayed (if present). If no fault or lockout codes are active, then system status codes are displayed. Alert codes are also displayed on the S40 thermostat.

Alert Codes	Inverter Code	Inverter LED Flash Code (number of flashes)		Priority	Alarm Description	Possible Causes and Clearing Alarm
		Red LED	Green LED			
E 432	28	2 flashes	8 flashes	Service Soon/ Service Critical	The inverter has detected a DC link high voltage condition.	Error occurs when the DC link capacitor voltage is greater than 480VDC. If condition is detected, outdoor unit will stop (compressor and fan). Antishort cycle is initiated. If condition occurs 10 times within an hour, system will lock out. System will stop. To clear, disconnect power to the indoor unit (24VAC power source to the outdoor control) which will power off the outdoor control and will open the outdoor unit contactor, which interrupts power to the inverter and then re-apply power.
E 433	29	2 flashes	9 flashes	Service Soon/ Service Critical	The inverter has detected a compressor over-current condition	Error occurs when compressor peak phase current is greater than 28A. Inverter will issue code 14 first and slow down to try to reduce the current. If the current remains high, outdoor unit will stop (compressor and fan). Antishort cycle is initiated. If condition occurs 5 times within an hour, the unitary control will cycle the contactor to prevent the unit from locking out. To clear, disconnect power to the indoor unit (24VAC power source to the outdoor control) which will power off the outdoor control and will open the outdoor unit contactor, which interrupts power to the inverter and then re-apply power.
E 434	53	5 flashes	3 flashes	Service Soon/ Service Critical	Outdoor control has lost communications with the inverter for greater than 3 minutes. Outdoor unit will stop all compressor demand. Outdoor control will attempt to establish communication multiple times and will automatically clear when the error clears. Unit will lock out after 60 minutes if communication is not established and will display a critical error code.	Issues: (1) Outdoor disconnect is off or outdoor power is off, when indoor power is on (source for 24VAC) (2) Loose electrical power connections (3) Interruption of main power to the inverter (4) Generator powers indoor unit, but not the outdoor unit. Corrective Actions: (1) To reset, cycle the indoor power off (source of 24VAC to outdoor unit) and back on. This will de-energize outdoor control and inverter by cycling the contactor. (2) Make sure the disconnect is on (3) Check electrical power supply connections (4) Check for proper main 230V power supply
E 435	60	6 flashes	OFF	Service Soon/ Service Critical	Inverter internal error.	When this error occurs, the outdoor control will cycle power to the inverter by opening the contactor for 2 minutes. Check that the EEPROM is properly seated. After power is cycled to the inverter 3 times, the outdoor unit is locked out.

TABLE 23. Outdoor Control 7-Segment Display Alert Codes and Inverter LED Flash Codes

NOTE - System fault and lockout codes take precedence over system status codes (cooling, heating operating percentages or defrost/dehumidification). Only the latest active fault or lockout codes are displayed (if present). If no fault or lockout codes are active, then system status codes are displayed. Alert codes are also displayed on the S40 thermostat.

Alert Codes	Inverter Code	Inverter LED Flash Code (number of flashes)		Priority	Alarm Description	Possible Causes and Clearing Alarm
		Red LED	Green LED			
E 436	62	6 flashes	2 flashes	Service Soon/ Service Critical	<p>Inverter heat sink temperature exceeded limit. Occurs when the heat sink temperature exceeds the inverter limit. Inverter issues code 13 first, then slows down to allow the heat sink to cool. If temperature remains high, outdoor unit stops (compressor and fan). Anti-short cycle is initiated. If condition occurs 5 times within an hour, the unitary control will cycle the contactor to prevent the unit from locking out.</p> <p>To clear, disconnect power to the indoor unit (24VAC power source to the outdoor control) which will power off the outdoor control and will open the outdoor unit contactor, which interrupts power to the inverter and then re-apply power.</p>	<p>Issue: Feedback from supplier tear down of inverter indicates that the screws that hold the inverter to the inverter board were loose causing poor contact between these two components.</p> <p>Corrective Action: Tighten screws that hold the heat sink to the inverter control board.</p> <p>NOTE: Wait five minutes to all capacitor to discharge before checking screws.</p>
E 437	65	6 flashes	5 flashes	Service Soon/ Service Critical	<p>Heat sink temperature sensor fault has occurred (temperature less than 4 °F or greater than 264°F after 10 minutes of operation).</p>	<p>This occurs when the temperature sensor detects a temperature less than 0.4°F or greater than 264°F after 10 minutes of operation. If condition is detected, outdoor unit will stop (compressor and fan). Antishort cycle is initiated. If condition occurs 5 times within an hour, system will lock out.</p> <p>To clear, disconnect power to the indoor unit (24VAC power source to the outdoor control) which will power off the outdoor control and will open the outdoor unit contactor, which interrupts power to the inverter and then re-apply power.</p>
E 438	73	7 flashes	3 flashes	Service Soon/ Service Critical	<p>The inverter has detected a PFC over current condition. This would be caused by a high load condition, high pressure, or outdoor fan failure. Outdoor control will display the code when the inverter has the error. After 3 minutes, the inverter will reset and the compressor will turn on again. If it happens 10 times within a 60 minute rolling time period, the OD control will lock out operation of the outdoor unit and display a critical code.</p>	<p>Issue: Possible issue is system running at high pressures. Check for high pressure trips or other alert codes in room thermostat and outdoor control.</p> <p>To clear, disconnect power to the indoor unit (24VAC power source to the outdoor control) which will power off the outdoor control and will open the outdoor unit contactor, which interrupts power to the inverter and then re-apply power.</p>

TABLE 23. Outdoor Control 7-Segment Display Alert Codes and Inverter LED Flash Codes

NOTE - System fault and lockout codes take precedence over system status codes (cooling, heating operating percentages or defrost/dehumidification). Only the latest active fault or lockout codes are displayed (if present). If no fault or lockout codes are active, then system status codes are displayed. Alert codes are also displayed on the S40 thermostat.

Alert Codes	Inverter Code	Inverter LED Flash Code (number of flashes)		Priority	Alarm Description	Possible Causes and Clearing Alarm
		Red LED	Green LED			
E 439	12	1 flash	2 flashes	Dealer Info Only	Compressor slowdown due to high input current.	This error code is primarily for informational purposes as the inverter controls the compressor to operate within design parameters. Typically the inverter will make a minor speed reduction of 4 Hz (approximately a 5-6% speed reduction) for a brief period of time and to reduce the input current and will then resume normal operation.
E 440	13	1 flash	3 flashes	Dealer Info Only	Heat sink temperature is approaching limit. The compressor speed automatically slows to reduce heat sink temperature. The control sets indoor CFM and outdoor RPM to values according to demand percentage rather than the actual Hz. Alarm is automatically cleared.	<p>This error code is primarily for informational purposes as the inverter controls the compressor speed to operate within design parameters. Typically the inverter will make a minor speed reduction of 4 Hz (approximately a 5-6% speed reduction) for a brief period of time and to reduce the heat sink temperature and will then resume normal operation. This may occur at high outdoor temperatures (above 110°F) for brief periods of time (3 – 4 minutes) and is normal and expected operation of the inverter controlling the compressor safely within design parameters.</p> <p>The inverter finned aluminum heat sink is located on the back side of the inverter in the condenser air stream. If the alert code 440 occur frequently, especially at lower outdoor temperatures, check the heat sink for debris that may reduce heat transfer or possible obstructions that may impact air flow across the heat sink.</p> <p>The inverter will begin to briefly reduce the compressor speed when the heat sink temperature rises above 167°F and will allow the inverter to resume the requested compressor demand speed once the inverter heat sink reaches 150°F. The heat sink temperature, compressor speed in Hertz & the Inverter Compressor Speed Reduction status (“On” or “Off”) notification can be viewed under the outdoor unit Diagnostics section of the thermostat dealer control center on units installed with an S40 thermostat.</p>

TABLE 23. Outdoor Control 7-Segment Display Alert Codes and Inverter LED Flash Codes

NOTE - System fault and lockout codes take precedence over system status codes (cooling, heating operating percentages or defrost/dehumidification). Only the latest active fault or lockout codes are displayed (if present). If no fault or lockout codes are active, then system status codes are displayed. Alert codes are also displayed on the S40 thermostat.

Alert Codes	Inverter Code	Inverter LED Flash Code (number of flashes)		Priority	Alarm Description	Possible Causes and Clearing Alarm
		Red LED	Green LED			
E 441	14	1 flash	4 flashes	Dealer Info Only	Compressor slowdown due to high compressor current. Compressor current is approaching limit. The compressor speed automatically slows. The control sets indoor CFM and outdoor RPM to values according to demand percentage rather than the actual Hz. Alarm is automatically cleared..	<p>This error code is primarily for informational purposes as the inverter controls the compressor to operate within design parameters. Alert code 441 typically occurs at startup as the compressor as the currently increases rapidly during startup.</p> <p>The inverter will reduce the compressor speed by 4 hz and slow the compressor ramp up speed to the requested compressor demand (capacity). This is normal and expected operation of the inverter to control the compressor within design parameters. In most cases the alert code 441 does not require any additional service or diagnostic procedures.</p> <p>E441 may also occur if the system is operating at high pressures.</p> <p>This error code is primarily for informational purposes as the inverter controls the compressor to operate within design parameters. Alert code 441 typically occurs at startup as the compressor as the currently increases rapidly during startup.</p> <p>The inverter will reduce the compressor speed by 4 hz and slow the compressor ramp up speed to the requested compressor demand (capacity). This is normal and expected operation of the inverter to control the compressor within design parameters. In most cases the alert code 441 does not require any additional service or diagnostic procedures.</p> <p>E441 may also occur if the system is operating at high pressures.</p>
E 443				Service Soon	Incorrect appliance unit size code selected	<p>Check for proper configuring under unit size codes for outdoor unit on configuration guide or in installation instructions. If replacing inverter, verify inverter model matches unit size. The alarm/fault clears after the correct match is detected following a reset.</p> <p>Remove the thermostat from the system while applying power and reprogramming.</p>
E 444				Service Soon	Reversing valve position error	Reversing valve position does not match the position commanded by the controller. Verify reversing valve wiring connections are secure.
E 480				Service Soon	EEV control board fault	The EEV control board has stopped communicating with the outdoor control. Heat pump heating operation stopped. Check EEV communication cable and EEV control board power.
E 490				Service Soon	Injection EEV coil current too high	Injection operation stopped, heat pump heating can continue. Check injection EEV coil connection to the EEV controller.

System Refrigerant

IMPORTANT

The system must be operating at full capacity during charging. Using the Charge Mode Jumper on the outdoor control ensures the unit is running at 100% capacity. Confirm outdoor unit running capacity.

This section outlines the procedures to:

- 1 - Connect a gauge set for testing and charging as illustrated in figure 49.
- 2 - Check and adjust indoor airflow as described in figure 50.
- 3 - Add or remove refrigerant using the weigh-in method shown in figure 51.
- 4 - Verify the charge using the subcooling method described in figure 52.

IMPORTANT: Unit must be operating at 100% capacity to be charged properly.

ADDING OR REMOVING REFRIGERANT

This system uses R454B refrigerant, which is a zeotropic blend. Unit must be charged with liquid refrigerant only.

INDOOR AIRFLOW CHECK

Check airflow using the Delta-T (DT) process using the illustration in figure 54.

The diagnostic screen on the S40 thermostat and the S40 Dealer Setup App displays the indoor CFMs.

On systems installed with the S40 thermostat, the Cooling - Maximum Rate Test located in the Test section of the Dealer Control Center of the thermostat or the Lennox Dealer Setup App may be used to operate the unit at maximum capacity during charging.

CHARGE SYSTEM AT 100% CAPACITY

System charging must be performed with the unit operating at maximum cooling or heating capacity (100% capacity). The unit can be operated at maximum capacity by entering the test mode at the S40 thermostat or by using the Lennox Dealer Setup App. The S40 Test Mode can be selected by going to Menu>Advanced Settings> View Dealer Control Center> Test and then Cooling - Maximum Rate Test or Heating - Maximum Rate Test. The Seven-segment display on the outdoor control will show outdoor unit running capacity.

GAUGE SET

CONNECTIONS FOR TESTING AND CHARGING

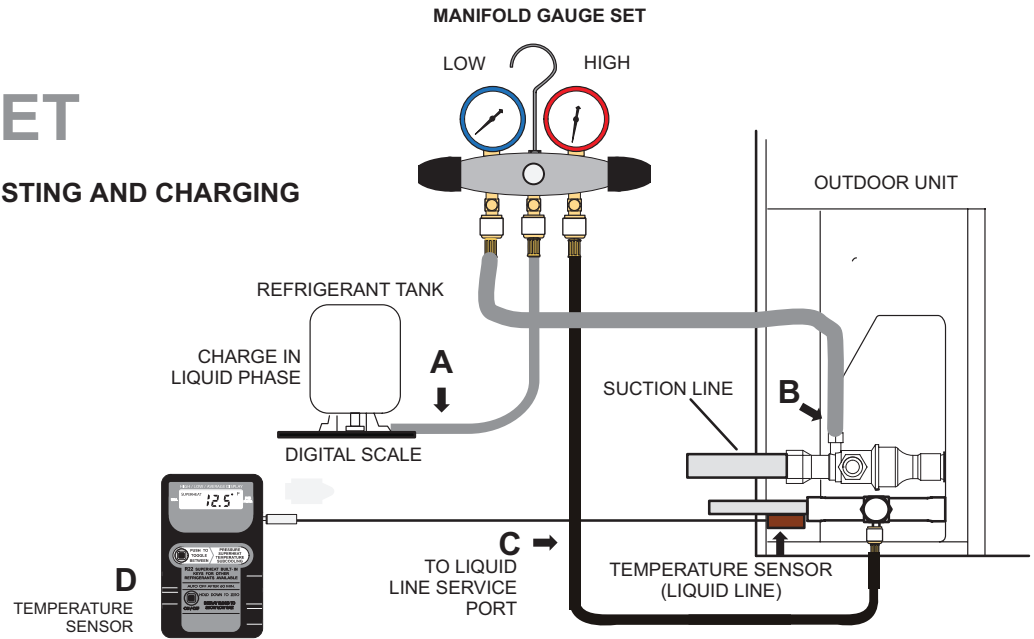

- CLOSE MANIFOLD GAUGE SET VALVES AND CONNECT THE CENTER HOSE TO A CYLINDER OF R454B SET FOR LIQUID PHASE CHARGING.
- CONNECT THE MANIFOLD GAUGE SET'S LOW PRESSURE SIDE TO THE SUCTION LINE SERVICE PORT.
- CONNECT THE MANIFOLD GAUGE SET'S HIGH PRESSURE SIDE TO THE LIQUID LINE SERVICE PORT.
- POSITION TEMPERATURE SENSOR ON LIQUID LINE NEAR LIQUID LINE SERVICE PORT.

FIGURE 48. Gauge Set Connections

AIRFLOW

INDOOR COIL

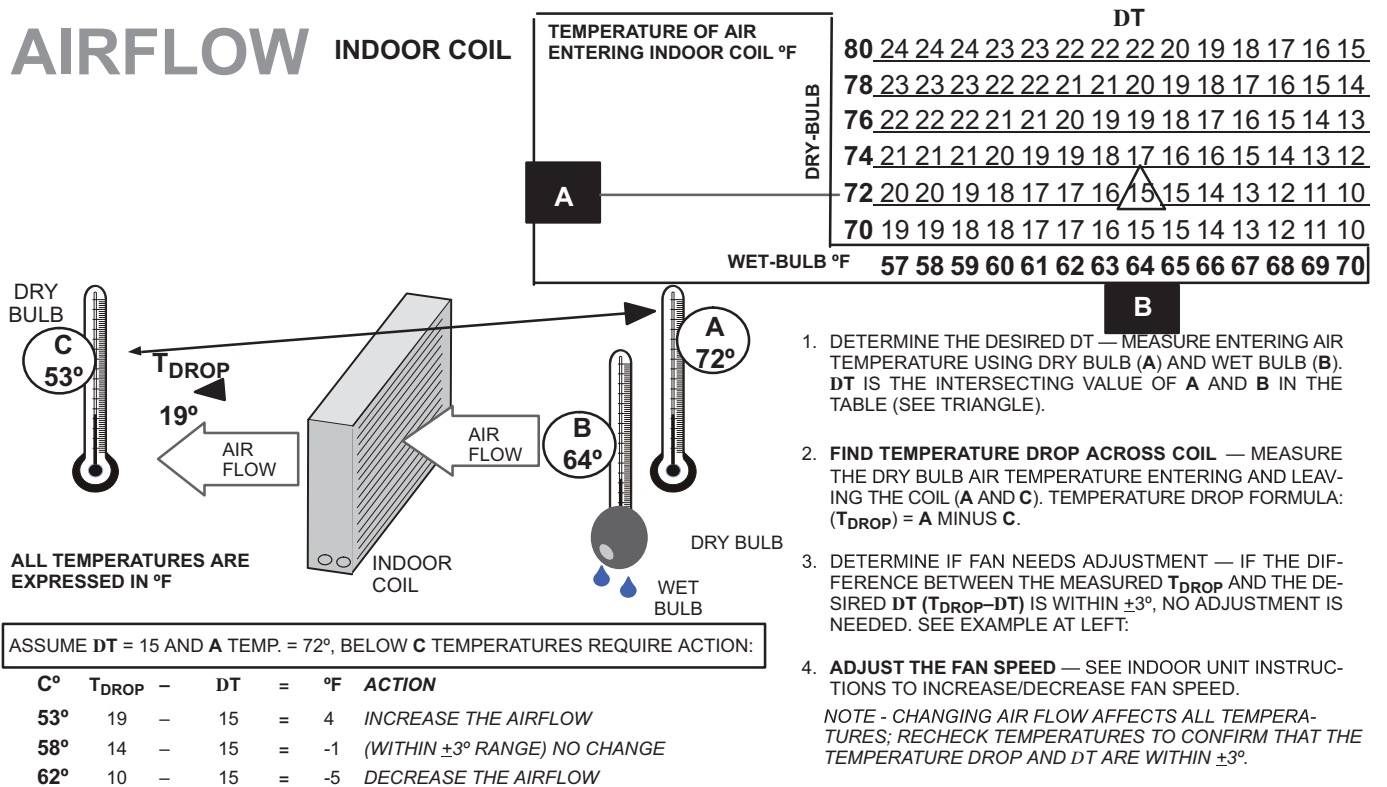

FIGURE 49. Checking Indoor Airflow over Evaporator Coil using Delta-T Chart

Verify the unit is electrically grounded before charging the system. Extreme care shall be taken not to overfill the refrigerating system.

Charge should be checked and adjusted using information outlined in this section and in the tables provided on the charging label on the unit's control access panel.

R454B is a zeotropic blend of two refrigerants. At any given refrigerant pressure, R454B will have two saturation temperatures, a saturated liquid temperature and a saturated vapor temperature. See R454B Refrigerant Pressure Temperature Chart in the installation and service manual for saturation temperatures.

R454B units must be charged with liquid refrigerant. Follow conventional charging procedures when charging the system. The technician is required to mark the total charge of the installed system on the unit nameplate, which includes the nameplate charge (factory charge) and additional charge that is added to the system at the time of installation.

The R454B refrigerant cylinders are provided with a 1/4" LH flare connection, therefore a 1/4" LH female flare adapter will be required. Connect manifold gauges and hoses following conventional charging procedures. Position the R454B refrigerant cylinder to deliver liquid refrigerant.

SL22KLV unit is factory charged with R454B. Refer to unit Charging Label for baseline line set length for factory unit charge and Additional Charge guidelines.

Initiate a call for cooling and allow the refrigerant pressures and temperatures to stabilize. Adjust the charge to using the subcooling method. The unit charging label provides the target Subcooling Values. Record the liquid line temperature. Measure the liquid line pressure and use the value to determine the Saturated Liquid Temperature. Calculate subcooling by subtracting the liquid line temperature from the Saturated liquid temperature.

Subcooling = Saturated Liquid Temperature – Liquid Line Temperature

Compare the results with the unit charging label.

Once system charging has been completed, the additional charge and total charge must be marked on the unit nameplate. Total Charge = Factory Charge + Additional charge. The total charge is marked on the space adjacent to "Total Charge". See nameplate below.

Detailed information is given in the SL22KLV Installation and Service Procedures manual, which is available on LennoxPros.com.

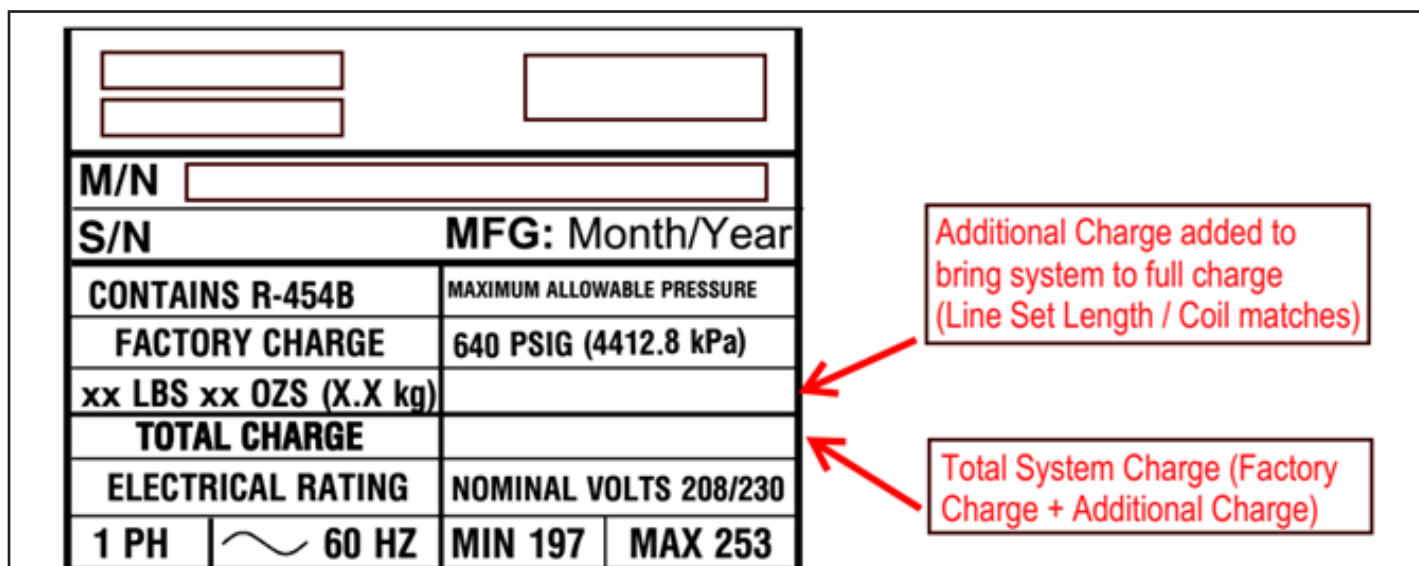

FIGURE 50. SL22KLV Charging Label

TABLE 24. R454B Temperature (°F) - Pressure (Psig)

Pressure (psig)	Saturated Liquid Temp (F°)	Saturated Vapor Temp (F°)	Pressure (psig)	Saturated Liquid Temp (F°)	Saturated Vapor Temp (F°)	Pressure (psig)	Saturated Liquid Temp (F°)	Saturated Vapor Temp (F°)	Pressure (psig)	Saturated Liquid Temp (F°)	Saturated Vapor Temp (F°)
0	-58.9	-57.1	158	58.9	61.3	272	93.0	95.4	362	113.4	115.6
25	-19.2	-17.2	160	59.6	62.0	274	93.5	95.9	364	113.8	116.0
30	-13.9	-11.8	165	61.4	63.8	276	94.0	96.4	366	114.2	116.4
35	-9.0	-6.9	170	63.1	65.5	278	94.5	96.9	368	114.6	116.8
40	-4.4	-2.3	175	64.9	67.3	280	95.0	97.4	370	115.0	117.2
45	-0.2	1.9	180	66.6	69.0	282	95.5	97.9	372	115.4	117.6
50	3.7	5.9	185	68.2	70.6	284	96.0	98.4	374	115.8	118.0
55	7.5	9.7	190	69.8	72.2	286	96.5	98.8	376	116.2	118.4
60	11.0	13.2	195	71.4	73.8	288	97.0	99.3	378	116.6	118.8
65	14.4	16.6	200	73.0	75.4	290	97.5	99.8	380	117.0	119.2
70	17.6	19.8	202	73.6	76.0	292	97.9	100.3	382	117.4	119.6
75	20.6	22.9	204	74.2	76.6	294	98.4	100.7	384	117.7	119.9
80	23.6	25.9	206	74.9	77.3	296	98.9	101.2	386	118.1	120.3
85	26.4	28.7	208	75.5	77.9	298	99.4	101.7	388	118.5	120.7
90	29.1	31.4	210	76.1	78.5	300	99.8	102.2	390	118.9	121.1
95	31.7	34.0	212	76.7	79.1	302	100.3	102.6	392	119.3	121.5
100	34.3	36.6	214	77.3	79.7	304	100.8	103.1	394	119.7	121.9
102	35.3	37.6	216	77.9	80.2	306	101.2	103.5	396	120.1	122.2
104	36.2	38.6	218	78.4	80.8	308	101.7	104.0	398	120.5	122.6
106	37.2	39.5	220	79.0	81.4	310	102.1	104.4	400	120.8	123.0
108	38.1	40.5	222	79.6	82.0	312	102.6	104.9	405	121.8	123.9
110	39.1	41.4	224	80.2	82.6	314	103.0	105.4	410	122.7	124.9
112	40.0	42.4	226	80.8	83.1	316	103.5	105.8	415	123.6	125.8
114	40.9	43.3	228	81.3	83.7	318	103.9	106.2	420	124.6	126.7
116	41.8	44.2	230	81.9	84.3	320	104.4	106.7	425	125.5	127.6
118	42.7	45.1	232	82.4	84.8	322	104.8	107.1	430	126.4	128.5
120	43.6	46.0	234	83.0	85.4	324	105.3	107.6	435	127.3	129.4
122	44.5	46.9	236	83.6	86.0	326	105.7	108.0	440	128.2	130.2
124	45.4	47.7	238	84.1	86.5	328	106.2	108.5	445	129.0	131.1
126	46.2	48.6	240	84.7	87.1	330	106.6	108.9	450	129.9	132.0
128	47.1	49.4	242	85.2	87.6	332	107.0	109.3	460	131.6	133.7
130	47.9	50.3	244	85.8	88.1	334	107.5	109.7	470	133.3	135.3
132	48.8	51.1	246	86.3	88.7	336	107.9	110.2	480	135.0	137.0
134	49.6	51.9	248	86.8	89.2	338	108.3	110.6	490	136.7	138.6
136	50.4	52.8	250	87.4	89.7	340	108.8	111.0	500	138.3	140.2
138	51.2	53.6	252	87.9	90.3	342	109.2	111.5	510	139.9	141.8
140	52.0	54.4	254	88.4	90.8	344	109.6	111.9	520	141.5	143.3
142	52.8	55.2	256	88.9	91.3	346	110.0	112.3	530	143.0	144.8
144	53.6	56.0	258	89.5	91.8	348	110.5	112.7	540	144.5	146.3
146	54.3	56.7	260	90.0	92.4	350	110.9	113.1	550	146.1	147.8
148	55.1	57.5	262	90.5	92.9	352	111.3	113.5	560	147.5	149.2
150	55.9	58.3	264	91.0	93.4	354	111.7	114.0	570	149.0	150.7
152	56.6	59.0	266	91.5	93.9	356	112.1	114.4	580	150.5	152.1
154	57.4	59.8	268	92.0	94.4	358	112.5	114.8	590	151.9	153.5
156	58.1	60.5	270	92.5	94.9	360	112.9	115.2	600	153.3	154.8

NOTES

1. R-454B is a zeotropic blend and must be charged with liquid refrigerant only.
2. Saturated liquid temperature is used to calculate liquid subcooling.
3. Saturated vapor temperature is used to calculate suction superheat.
4. See unit charging label for subcooling and additional charging information.

Use the WEIGH-IN method for adding initial refrigerant charge, and then use SUBCOOLING method for verifying refrigerant charge.

WEIGH-IN CHARGING METHOD

64°F (17.7°C) and Below

Amount specified on nameplate Adjust amount for variation in line set length and liquid line diameter using table below. Total charge

± = _____



Liquid Line Set Diameter	R454B (ounces per foot)
5/16"	0.40
3/8"	0.60
1/2"	1.00

NOTE - Insulate liquid line when it is routed through areas where the surrounding ambient temperature could become higher than the temperature of the liquid line or when pressure drop is equal to or greater than 20 psig.

NOTE - The nameplate is shown for illustration purposes only. Go to actual nameplate on outdoor unit for charge information.

Charging Formula for Liquid Line Charge Adjustments

[(Line set oz./ft. x total length) - (factory charge for line set)] = charge adjustment

Example: Units are factory-charged for 15 feet (4.6 meters) of 3/8" line set. Factory charge for 3/8" is 0.60 oz/ft x 15 = 9.0 ounces.

FIGURE 51. Using R454B Weigh-In Method

SUBCOOLING CHARGING METHOD

*(All charging **MUST** be performed while system is operating either at maximum speed or 100% demand.)*

1. THE DIAGNOSTIC SCREEN ON THE THERMOSTAT OR OUTDOOR CONTROL 7-SEGMENT DISPLAY WILL SHOW INDOOR AND OUTDOOR MOTOR CFMS OR RPMS.
2. MEASURE OUTDOOR AMBIENT TEMPERATURE.
3. CONNECT GAUGE SET.
4. CHECK LIQUID AND VAPOR LINE PRESSURES. COMPARE PRESSURES WITH COOLING MODE NORMAL OPERATING PRESSURES IN THE APPLICABLE CHARGING STICKER, NORMAL OPERATING PRESSURES AT MAXIMUM CAPACITY.

NOTE - THE REFERENCE TABLE IS A GENERAL GUIDE. EXPECT MINOR PRESSURE VARIATIONS. SIGNIFICANT DIFFERENCES MAY MEAN IMPROPER CHARGE OR OTHER SYSTEM PROBLEM.
5. SET THERMOSTAT FOR HEAT/COOL DEMAND, DEPENDING ON MODE BEING USED:

USE COOLING MODE — WHEN THE OUTDOOR AMBIENT TEMPERATURE IS 60°F (15°C) AND ABOVE. TARGET SUBCOOLING VALUES (MAXIMUM / 100% CAPACITY) IN APPLICABLE CHARGING STICKER ARE BASED ON 70 TO 80°F (21-27°C) INDOOR RETURN AIR TEMPERATURE; IF NECESSARY, OPERATE HEATING TO REACH THAT TEMPERATURE RANGE; THEN SET THE INITIAL COOLING DEMAND AT MAXIMUM CAPACITY. THE PREFERRED METHOD IS TO USE THE "CHARGE MODE" JUMPER ON THE OUTDOOR CONTROL. SEE CHARGE MODE JUMPER SECTION ON PAGE 80. WHEN PRESSURES HAVE STABILIZED, CONTINUE WITH STEP 6.

USE HEATING MODE
6. READ THE LIQUID LINE TEMPERATURE; RECORD IN THE LIQ° SPACE.
7. READ THE LIQUID LINE PRESSURE; THEN FIND ITS CORRESPONDING TEMPERATURE IN THE TEMPERATURE/ PRESSURE CHART LISTED IN THE APPLICABLE CHARGING STICKER AND RECORD IT IN THE SAT° SPACE.
8. SUBTRACT LIQ° TEMPERATURE FROM SAT° TEMPERATURE TO DETERMINE SUBCOOLING; RECORD IT IN SC° SPACE.
9. COMPARE SC° RESULTS WITH APPLICABLE CHARGING STICKER, BEING SURE TO NOTE ANY ADDITIONAL CHARGE FOR LINE SET AND/OR MATCH-UP.
10. IF SUBCOOLING VALUE IS GREATER THAN SHOWN IN APPLICABLE CHARGING STICKER FOR THE APPLICABLE UNIT, REMOVE REFRIGERANT; IF LESS THAN SHOWN, ADD REFRIGERANT.
11. IF REFRIGERANT IS ADDED OR REMOVED, REPEAT STEPS 6 THROUGH 10 TO VERIFY CHARGE.
12. DISCONNECT GAUGE SET AND RE-INSTALL BOTH THE LIQUID AND SUCTION SERVICE VALVE CAPS.

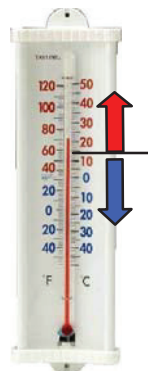

USE COOLING MODE

60°F (15°C)

USE HEATING MODE

SAT° _____

LIQ° - _____

SC° = _____

FIGURE 52. Using R454B Subcooling Method - High Speed (High Capacity)

FIGURE 53. SL22KLV Charging Label

R454B CHARGING INFORMATION – FOR COMPLETE CHARGING DETAILS, REFER TO THE OUTDOOR UNIT INSTALLATION AND SERVICE PROCEDURE

Maintenance checks using the Normal Operating Pressures table

Table 2 may be used to help perform maintenance checks. This table is not a procedure for charging the system and any minor variations in the pressures may be expected due to differences in installations. However, significant deviations could mean that the system is not properly charged or that a problem exists with some component in the system.

Charge Using the Subcooling Method

Cooling Mode – When the outdoor ambient temperature is 60°F (15°C) and above, use the cooling mode to adjust the charge using the subcooling method. Target subcooling values in table 1 are based on 70 to 80°F (21-27°C) indoor return air temperature.

Heating Mode – When the outdoor ambient temperature is below 60°F (15°C), use the heating mode to adjust the charge using the subcooling charge levels (table). Target subcooling values in table 1 are based on 65-75°F (18-24°C) indoor return air temperature.

IMPORTANT !

R454B is a zeotropic blend. Charge unit with liquid only. Use saturated liquid temperature to calculate liquid subcooling.

Matchups/Charge Levels and Line Set Lengths

Table 2 lists all the Lennox recommended indoor unit matchups along with the charge levels for the various sizes of outdoor units. **Charge levels on the unit nameplate are based on installations with 30ft. (9.1m) line sets; on line sets with 3/8”(9.5mm) liquid line, add 3oz. additional refrigerant for every 5ft. longer than 30ft. If line length is less than 30ft., subtract this amount (see Installation Instructions for more details).**

Charge Using the Weigh-in Method

If the system is void of refrigerant, locate and repair any leaks and then weigh in the refrigerant charge into the unit. For charge adjustments, be sure to consider line set length differences and, referring to table 1, adjust for the matchup difference.

- 1 - Recover the refrigerant from the unit.
- 2 - Conduct leak check; evacuate as previously outlined.
- 3 - Weigh in the unit nameplate charge, adjusting for matchup and line set length differences. If weighing facilities are not available use the Subcooling method.

Table 1 – Normal Operating Pressures (Liquid ±10 and Suction ±5 psig)

Heating Mode						Cooling Mode					
°F*	20	30	40	50	60	65	75	85	95	105	115
SIZE	LIQ/VAP	LIQ/VAP	LIQ/VAP	LIQ/VAP	LIQ/VAP	LIQ/VAP	LIQ/VAP	LIQ/VAP	LIQ/VAP	LIQ/VAP	LIQ/VAP
-024	47/301	55/255	78/282	101/307	120/327	141/230	142/270	144/315	145/341	148/426	150/496
-036	55/267	72/275	74/298	101/302	121/315	134/230	136/270	137/315	138/367	139/426	140/493
-048	54/262	67/275	82/290	98/303	116/318	129/230	130/268	132/312	134/361	135/415	138/471
-060	48/283	44/267	74/313	95/331	111/349	119/239	122/279	124/325	126/375	129/430	131/492

*Temperature of air entering the outdoor coil.

Table 2 – Indoor Unit Matches and Subcooling Charge Levels and Additional Charge**

Indoor Matchup	Subcool		Total Charge		Additional Charge	
	Heat (±5°F)	Cool (±1°F)	lbs	ozs	lbs	oz
SL22KLV-024						
CBK48MVT-042	16	15	11	6	0	12
CBK48MVT-018/024	22	14	10	14	0	4
CBK48MVT-030/036	27	14	10	10	0	0
CK40CT-30A	40	16	11	3	0	9
CK40CT-30B	40	16	11	3	0	9
CK40CT-36A	25	16	12	1	1	7
CK40CT-36B	25	16	12	1	1	7
CK40HT-42B	10	22	14	7	3	13
CK40HT-42C	16	16	10	13	0	3
CK40CT-48B	14	16	11	2	0	8
CK40DT-42B	59	17	12	3	1	9
SL22KLV-036						
CBK48MVT-060	14	15	17	7	1	5
CBK48MVT-042	39	16	17	2	1	0
CK40CT-49C	27	15	17	8	1	6
CBK48MVT-048	25	15	17	3	1	1
CK40CT-50/60C	33	12	16	6	0	4
CK40DT-50/60C	53	12	16	2	0	0
CK40HT-42B	24	15	17	11	1	9
CK40CT-60D	16	14	19	3	3	1

Indoor Matchup	Subcool		Total Charge		Additional Charge	
	Heat (±5°F)	Cool (±1°F)	lbs	ozs	lbs	oz
CK40CT-60C	14	14	16	10	1	8
CK40HT-51/61C	24	13	17	15	1	13
SL22KLV-048						
CBK48MVT-060	18	14	17	3	2	15
CBK48MVT-048	29	14	15	13	1	9
CK40CT-60C	26	15	14	4	0	0
CK40CT-49C	17	16	15	5	1	1
CHX35-60D-6F	15	15	16	12	2	4
CK40HT-42B	7	15	17	2	2	14
CK40HT-60D	18	16	16	4	3	0
CK40HT-51/61C	16	15	16	6	3	2
SL22KLV-060						
CBK48MVT-060	22	17	16	13	2	2
CK40CT-60C	16	18	17	9	2	14
CK40CT-49C	24	18	15	9	0	14
CK40HT-60D	24	20	16	11	2	0
CK40HT-42B	22	19	16	8	1	13
CK40CT-60D	12	17	16	5	0	4
CK40HT-51/61C	12	16	14	11	0	0

The values in this table are most popular match-up pressures; indoor match-up, indoor air quantity, and indoor load will cause the pressures to vary.

**Amount of charge required in addition to charge shown on unit nameplate.

For a list of all matches, please check forms on LennoxPros.com.



SL22KLV Advanced Diagnostics

The SL22KLV heat pump has factory installed liquid pressure transducers, liquid temperature sensors, suction pressure transducers and suction pressure temperature sensors that support advanced systems diagnostic information. The advanced diagnostic information is available at the S40 under the Dealer Dashboard, in the Diagnostic section of the Dealer Setup App and remotely on LennoxPros Service Dashboard.

The refrigerant pressures and temperatures along with the liquid subcooling value and suction superheat are now part of the diagnostic information. The SL22KLV refrigerant pressures, temperatures, superheat and subcooling can be checked while at the jobsite without connecting manifold gauges to the system and remotely at the office using LennoxPros service dashboard.

The Lennox Dealer Setup App can be downloaded for free at the App Store for Apple smartphones and tablets or at Google Play for Android smartphones and tablets.

Examples of the diagnostic information available on LennoxPros Service Dashboard and the Lennox Dealer Setup App are shown below.

Lennox Dealer Setup App

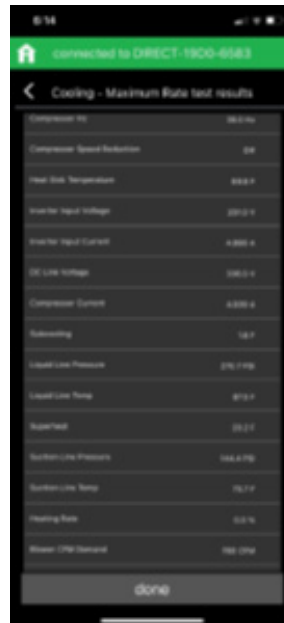
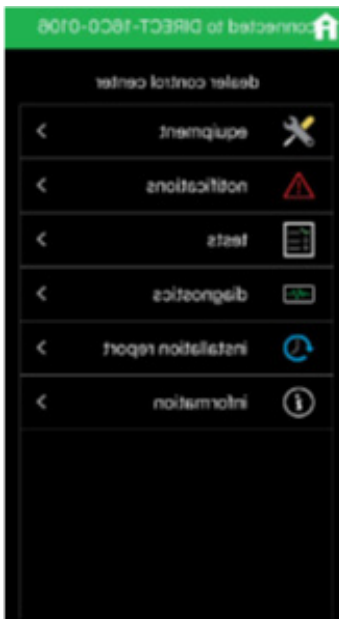

LennoxPros Service Dashboard

The screenshot shows the LennoxPros Service Dashboard. At the top, there is a navigation bar with a search bar, a 'START ORDER' button, and links for 'Advanced Search' and 'Recent Customers'. Below this is a secondary navigation bar with the Lennox logo, 'Pros.com', and various menu items like 'Product Catalog', 'Current Promotions', 'AI/BI Matchup', 'Repair Part Finder', 'Warranty', 'Service Dashboard', and 'My Learning'. A user profile for 'Thomas Johnson' is visible in the top right.

The main content area is titled '2025 Compliant Refrigerant Information'. Below this, there is a 'Service Dashboard' section with a search bar and a 'Serial Number' dropdown. The dashboard is divided into several panels:

- Home Systems:** A sidebar on the left showing 'Normal Home Systems (1)' with a green status indicator and the text 'All Equipment Normal'.
- User Profile:** A panel for 'BOB SMITH' at '123 Main St, Anytown, USA'.
- System History:** A panel showing 'No alerts in the last 12 months.' for the period 'April 2024 to March 2025'.
- System Control:** A large panel on the right displaying a 'System' control interface. It shows a current temperature of 68°F, a 'Feels Like' temperature, and a 33% humidity level. There are buttons for 'Temp', 'Status', and 'My Home'. Below the temperature display, there are settings for 'Heat to 66' and 'Cool to 85', with an 'Away' mode set to 57°F. A prominent red button labeled 'REMOTE IN' is at the bottom of this panel.
- Alerts & Reminders:** A section at the bottom left labeled 'Alerts & Reminders: System'.
- Equipment & Reports:** A section at the bottom right labeled 'Equipment & Reports'.

The screenshot shows a dark-themed 'Service Center' menu with six icons arranged in a 2x3 grid:

- Notifications:** Represented by a bell icon.
- Equipment Settings:** Represented by a wrench and screwdriver icon.
- Information:** Represented by an 'i' in a circle icon.
- Tests:** Represented by a checklist icon.
- Diagnostics:** Represented by a line graph icon.
- Installation Report:** Represented by a download arrow icon.

< Back

Diagnostics

 Heat Pump

Heat Pump

Stop

Comp. Short Cycle Delay Active	No
Cooling Rate	0.0 %
Heating Rate	0.0 %
Compressor Shift Delay Active	No
Defrost Status	Off
Reversing Valve Status	Heat Mode
High Pressure Switch	Closed
Low Pressure Switch	Closed
Top Cap Switch Status	Closed
Ambient Temp	58.4 F
Coil Temp	59.9 F
Target Frost Accumulation Time	180 min

Frost Accumulation Time	0 min
Compressor Active Alarm	0
Compressor Hz	0.0 Hz
Compressor Speed Reduction	Off
Heat Sink Temperature	62.6 F
Inverter Input Voltage	251.0 V
Inverter Input Current	0.500 A
DC Link Voltage	7.0 V
Compressor Current	0.000 A
Subcooling	0.1 F
Liquid Line Pressure	136.0 PSI
Liquid Line Temp	60.1 F
Superheat	0.4 F
Suction Line Pressure	161.6 PSI
Suction Line Temp	61.7 F

Suction Line Temp	61.7 F
Discharge Superheat	6.1 F
Discharge Line Pressure	164.3 PSI
Discharge Line Temp	69.8 F
HP EEV position	0
LI EEV position	0
HP EEV winding 1 resistance	43.6 ohm
HP EEV winding 2 resistance	42.9 ohm
HP EEV winding 3 resistance	43.4 ohm
HP EEV winding 4 resistance	43.3 ohm
LI EEV winding 1 resistance	43.6 ohm
LI EEV winding 2 resistance	42.9 ohm
LI EEV winding 3 resistance	43.4 ohm
LI EEV winding 4 resistance	43.3 ohm
Liquid Injection Solenoid State	Off