

7-3/8" wide x 8-1/2" tall

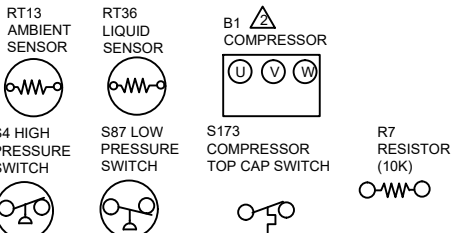

NOTE-
 FOR USE WITH COPPER CONDUCTORS ONLY. REFER TO UNIT RATING PLATE FOR MINIMUM CIRCUIT AMPACITY AND MAXIMUM OVERCURRENT PROTECTION SIZE
 REFER TO COMPRESSOR IN UNIT FOR ACTUAL TERMINAL ARRANGEMENT
 WARNING-ELECTRIC SHOCK HAZARD CAN CAUSE INJURY OR DEATH. UNIT MUST BE GROUNDED IN ACCORDANCE WITH NATIONAL AND LOCAL CODES

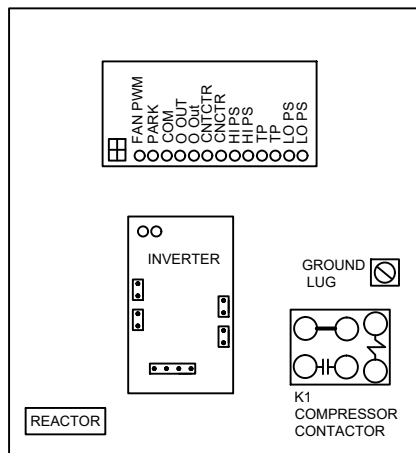
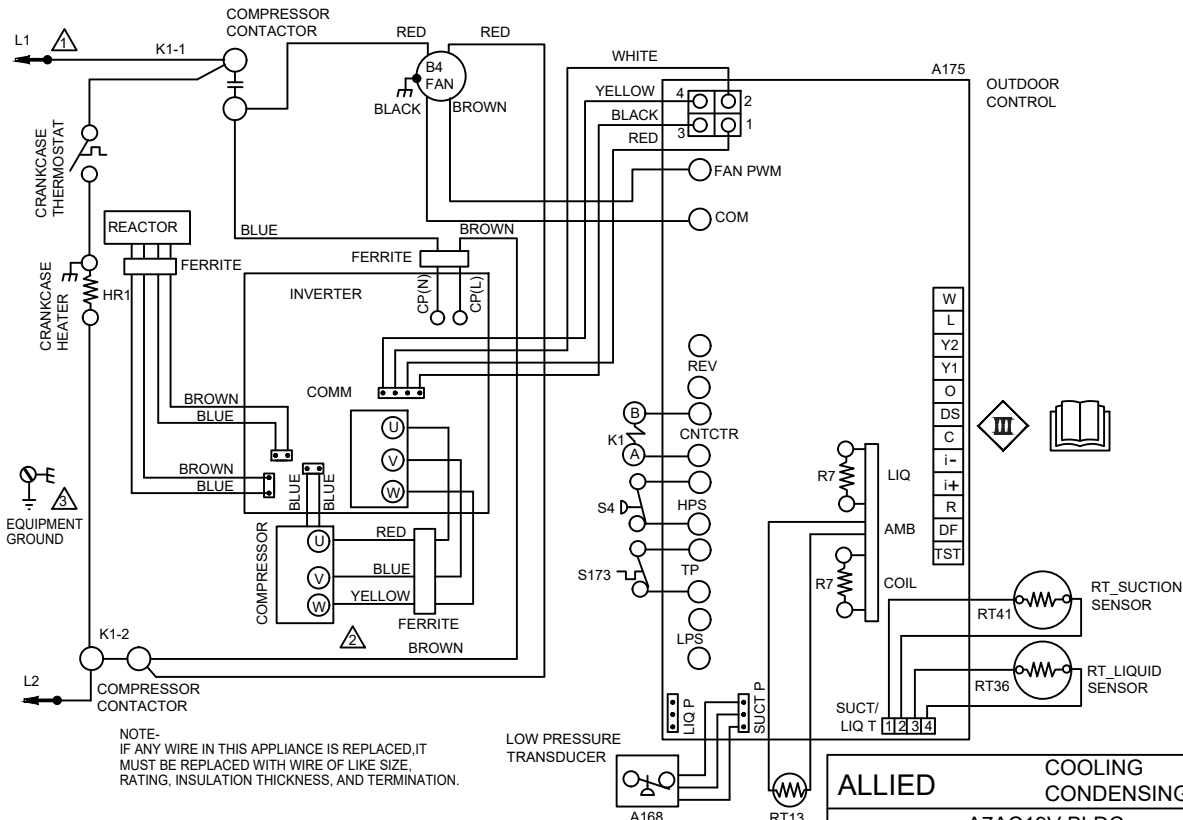

NOTE-
 IF ANY WIRE IN THIS APPLIANCE IS REPLACED, IT MUST BE REPLACED WITH WIRE OF LIKE SIZE, RATING, INSULATION THICKNESS, AND TERMINATION.

— LINE VOLTAGE FIELD INSTALLED
 - - - CLASS II VOLTAGE FIELD WIRING
 ← DENOTES OPTIONAL COMPONENTS

ALLIED		COOLING CONDENSING	
A7AC19V BLDC FAN MOTOR			
		<small>Supersedes</small>	
		Form No. 538606-01A	