

⚠ WARNING

To prevent serious injury or death:

- 1- Lock-out/tag-out before performing maintenance.
- 2- If system power is required (e.g., smoke detector maintenance), disable power to blower, remove fan belt where applicable, and ensure all controllers and thermostats are set to the “OFF” position before performing maintenance.
- 3- Always keep hands, hair, clothing, jewelry, tools, etc., away from moving parts.

Table of Contents

Dimensions	4
Parts Arrangement	5
Shipping and Packing List	6
General	6
Requirements	6
Unit Support.	8
Duct Connection	9
Rigging Unit for Lifting	9
Horizontal Air Discharge	9
Condensate Drains	10
Connect Gas Piping (Gas Units)	11
Pressure Test Gas Piping	12
High Altitude Derate.	13
Electrical Connections - Power Supply	13
Electrical Connections - Control Wiring	13
Balance Point Setpoint	14
Unit Power Up.	14
Mobile Service App	15
Blower Operation and Adjustments	18
Refrigerant Leak Detection System.	29
Start-Up	29

INSTALLATION INSTRUCTIONS

LHT/LDT036 (3 TON)

LHT/LDT048 (4 TON)

LHT/LDT060 (5 TON)

LHT/LDT072 (6 TON)

HEAT PUMP AND DUAL-FUEL PACKAGED UNITS

508455-01

5/2026

R-454B

Defrost Control	31
Diagnostic Sensors	32
RDS Sensors	35
Cooling Operation.	37
Heating Operation.	38
Gas Heat Start-Up (LDT Units)	39
Heating Operation and Adjustments	40
Electric Heat Start-Up (LHT Units)	40
SCR Electric Heat Controller (LHT Units).	40
Preventative Maintenance / Repair	41
Factory Unit Controller Settings.	53
Decommissioning	53

⚠ WARNING

Improper installation, adjustment, alteration, service or maintenance can cause property damage, personal injury or loss of life. Installation and service must be performed by a licensed professional HVAC installer or equivalent, service agency, or the gas supplier.

RETAIN THESE INSTRUCTIONS FOR FUTURE REFERENCES

Attention!

Use this QR code to download the mobile service app. Follow the prompts to pair the app with the unit control system and configure the unit. Refer to the “Download Mobile App” section in this manual and the Setup Guide provided with this unit. The QR code is also available in the unit control area.



The app can be downloaded from the appropriate iOS or Android store. Look for the following icon.



CAUTION

As with any mechanical equipment, contact with sharp sheet metal edges can result in personal injury. Take care while handling this equipment and wear gloves and protective clothing.

WARNING

Only manufacturer approved auxiliary devices are permitted to be installed in this unit.

WARNING

If this appliance is conditioning a space with an area smaller than T_{Amin} or stored in a space with an area smaller than A_{min} as defined by this instruction, then that space must be without continuously operating open flames (e.g. an operating gas appliance) or other potential ignition sources (e.g. an operating electric heater or similar hot surface). A flame-producing device may be installed in the same space if the device is provided with an effective flame arrest system.

CAUTION

Auxiliary devices which may be a potential ignition source shall not be installed in the duct work. Examples of such potential ignition sources are hot surfaces with a temperature exceeding 700°C and electric switching devices.

CAUTION

The appliance is not to be used by persons (including children) with reduced physical, sensory or mental capabilities, or lack of experience and knowledge, unless they have been given supervision or instruction

CAUTION

Children should be supervised not to play with the appliance.

CAUTION

Any personnel installing, decommissioning, or performing maintenance on the unit must be properly trained with A2L refrigerants.

CAUTION

Servicing shall be performed only as recommended by the manufacturer.

WARNING

•This appliance must be installed in accordance with local and national wiring regulations.

•If the appliance is not fitted with an option for full disconnection from power, a means of disconnection must be incorporated in the fixed wiring in accordance with national and local wiring regulations.

CAUTION

Leak Detection System installed. Unit must be powered except for service.

WARNING

•Do not use means to accelerate the defrosting process or to clean, other than those recommended by the manufacturer.

•The appliance shall be stored in a room without continuously operating ignition sources (for example: open flames, an operating gas appliance, or an operating electric heater).

•Do not pierce or burn.

•Be aware that refrigerants may not contain an odor

CAUTION

Any personnel installing, decommissioning, or performing maintenance on the unit must be properly trained with A2L refrigerants.

IMPORTANT

Pipe work, including piping material, pipe routing, and installation shall include protection from physical damage in operation and service, and be in compliance with national and local codes and standards, such as ASHRAE 15, ASHRAE 15.2, IAPMO Uniform Mechanical Code, ICC International Mechanical Code, or CSA B52. All field joints shall be accessible for inspection prior to being covered or enclosed.

IMPORTANT

Refrigerant sensors for refrigerant detection systems shall only be replaced with sensors specified by the appliance manufacturer.

CAUTION

This unit is equipped with electrically powered safety measures. To be effective, the unit must be electrically powered at all times after installation, other than when servicing.

A2L Refrigerant Considerations

Ensure that the area is in the open or that it is adequately ventilated before breaking into the system or conducting any hot work. A degree of ventilation shall continue during the period that the work is carried out. The ventilation should safely disperse any released refrigerant and preferably expel it externally into the atmosphere.

Check that cabling will not be subject to wear, corrosion, excessive pressure, vibration, sharp edges or any other adverse environmental effects, taking into account the effects of aging or continual vibration from sources such as compressors or fans.

Under no circumstances shall potential sources of ignition be used when searching for or detection of refrigerant leaks. **A halide torch (or any other detector using a naked flame) shall not be used.** Electronic leak detectors may be used to detect refrigerant leaks but, in the case of flammable refrigerants, the sensitivity may not be adequate, or may need re-calibration. (Detection equipment shall be calibrated in a refrigerant-free area.) Ensure that the detector is not a potential source of ignition and is suitable for the refrigerant used. Leak detection equipment shall be set at a percentage of the LFL of the refrigerant and shall be calibrated to the refrigerant employed, and the appropriate percentage of gas (25 % maximum) is confirmed. **Leak detection fluids are also suitable for use with most refrigerants but the use of detergents containing chlorine shall be avoided as the chlorine may react with the refrigerant and corrode the copper pipe-work. If a leak is suspected, all naked flames shall be removed/extinguished.** If a leakage of refrigerant is found which requires brazing, all of the refrigerant shall be recovered from the system, or isolated (by means of shut off valves) in a part of the system remote from the leak.

When breaking into the refrigerant circuit to make repairs – or for any other purpose – conventional procedures shall be used. However, for flammable refrigerants it is important that best practices be followed since flammability is a consideration.

The following procedure shall be adhered to:

- Safely remove refrigerant following local and national regulations.
- Evacuate the circuit.
- Purge the circuit with inert gas.
- Evacuate.
- Purge the circuit with inert gas.
- Open the circuit

The refrigerant charge shall be recovered into the correct recovery cylinders if venting is not allowed by local and national codes. For appliances containing flammable refrigerants, the system shall be purged with oxygen-free nitrogen to render the appliance safe for flammable refrigerants. This process might need to be repeated several times. Compressed air or oxygen shall not be used for purging refrigerant systems. Refrigerants purging shall be achieved by breaking the vacuum in the system with oxygen-free nitrogen and continuing to fill until the working pressure is achieved, then venting to atmosphere, and finally pulling down to a vacuum. This process shall be vented down to atmospheric pressure to enable work to take place. Ensure that the outlet for the vacuum pump is not close to any potential ignition sources and that ventilation is available.

LHT/LDT036, 048, 060, 072 DIMENSIONS in. - Gas heat section shown

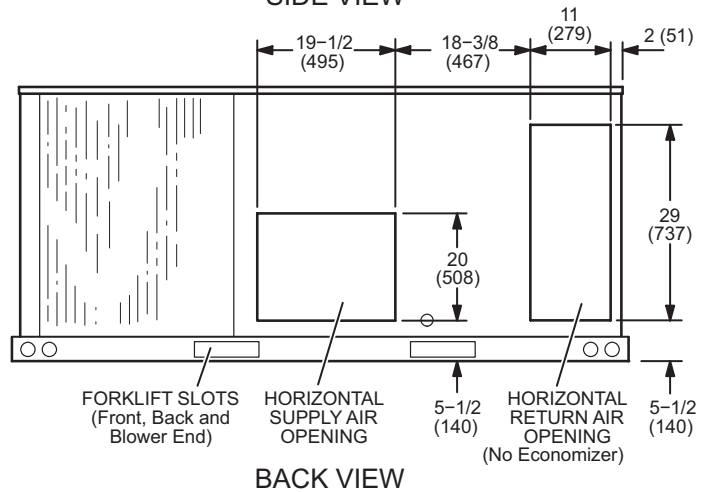
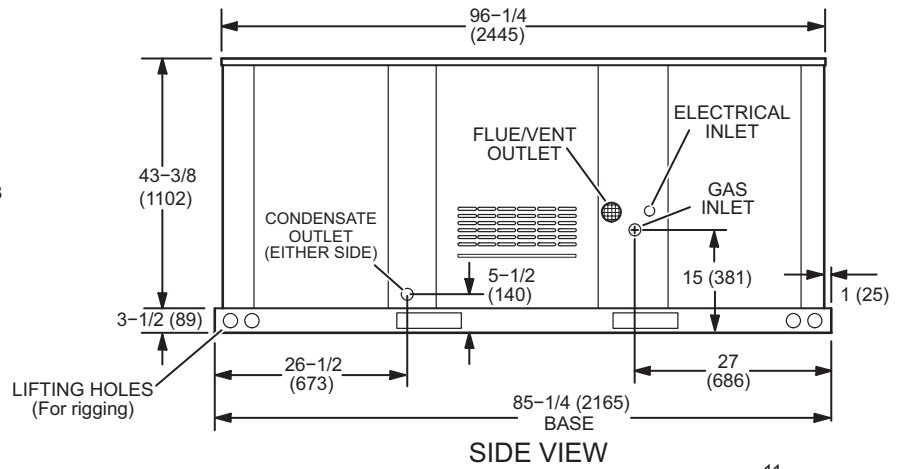
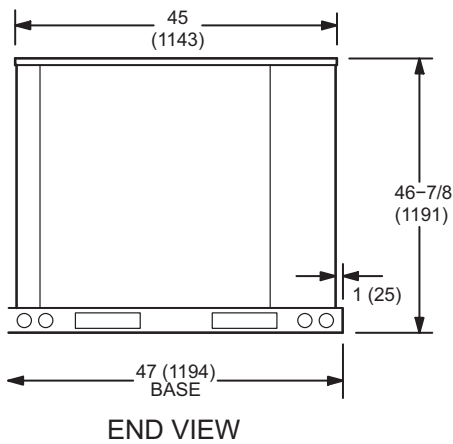
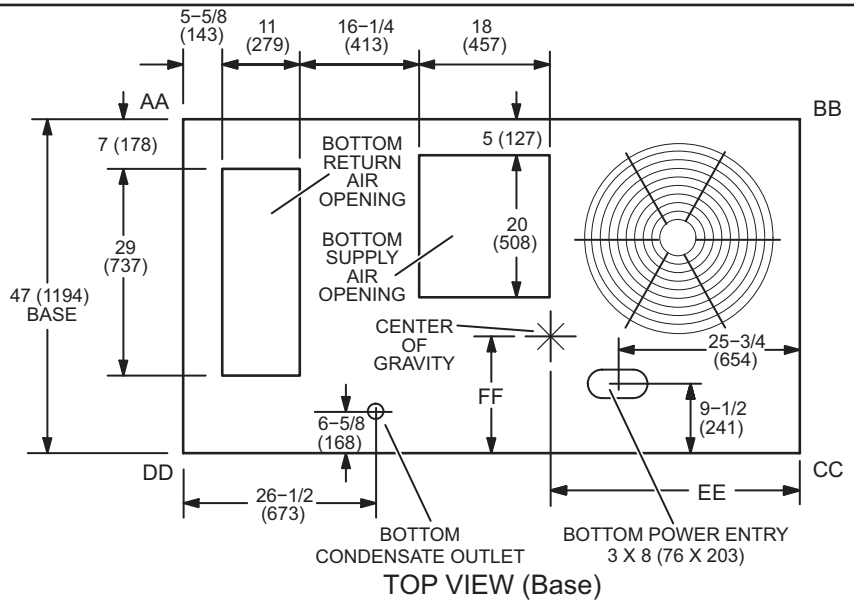

LHT036, 048, 060, 072 PARTS ARRANGEMENT

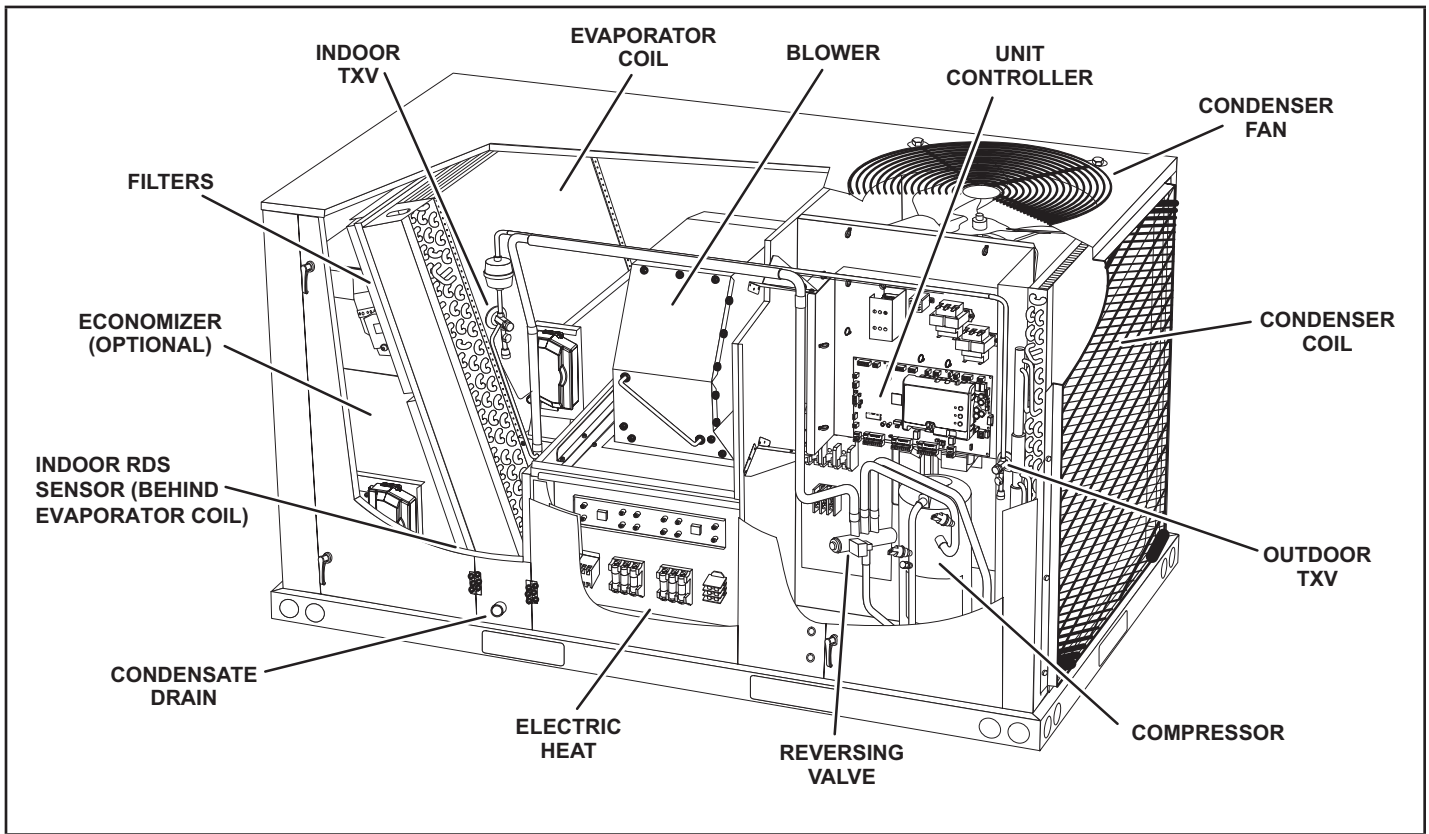

LDT036, 048, 060, 072 PARTS ARRANGEMENT

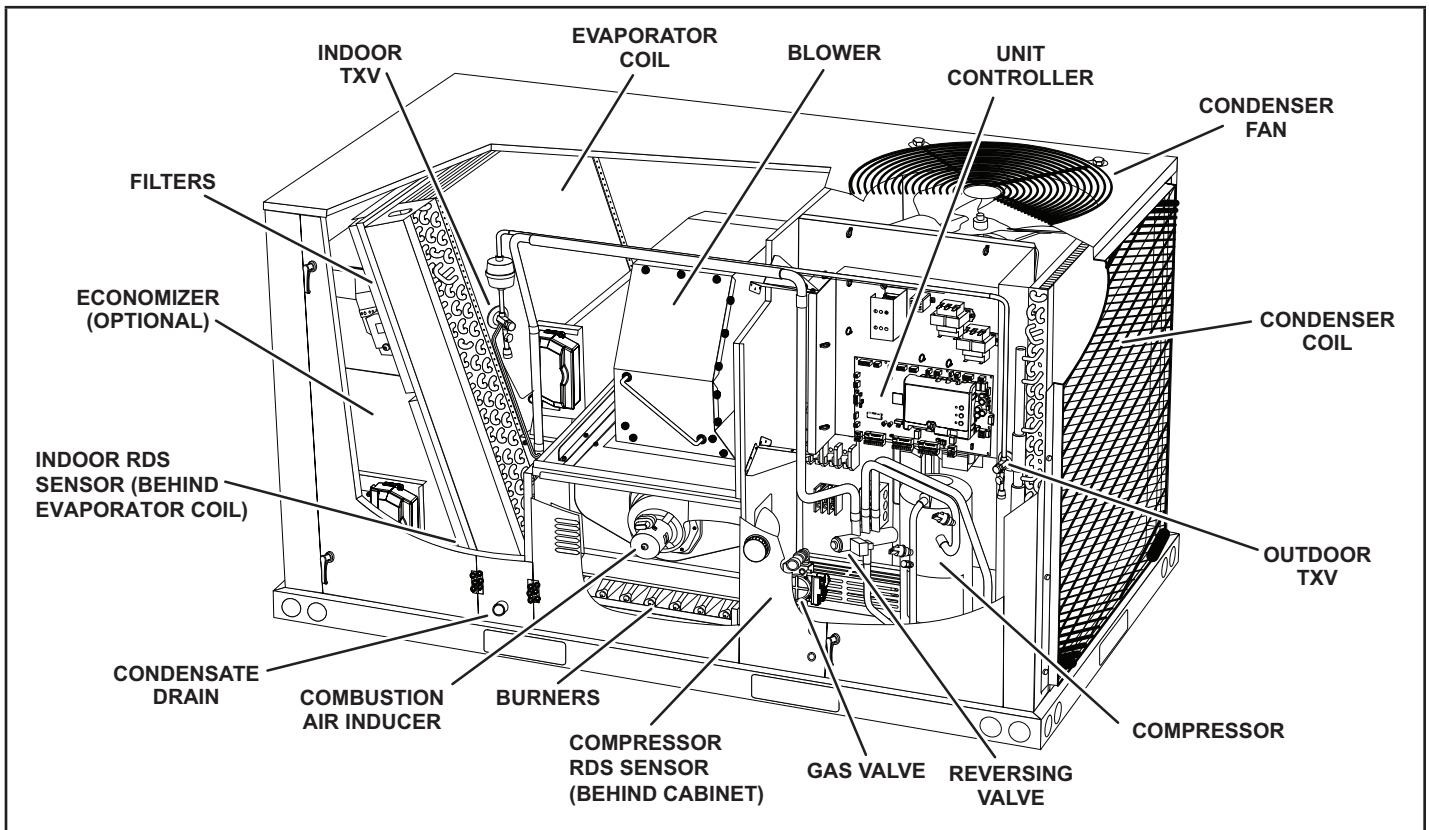

Shipping and Packing List

Package 1 of 1 contains:

1 - Assembled unit

Check unit for shipping damage. Receiving party should contact last carrier immediately if shipping damage is found.

Top Cap Packaging

Once lumber, bracket, and screws have been removed from the top of the unit, replace the screws in the corners of the cabinet. See FIGURE 2.

General

These instructions are intended as a general guide and do not supersede local codes in any way. Authorities having jurisdiction should be consulted before installation.

The LDT heat pump/gas heating (dual-fuel) packaged rooftop unit is available in 65,000, 108,000, or 150,000 Btuh heating inputs. The LHT heat pump packaged rooftop unit is the same basic design as the LDT unit except for the heating section. Optional electric heat is factory- or field-installed in LHT units.

The LHT/LDT units have 3, 4, 5, and 6-ton cooling capacities.

Units are equipped with fin/tube condenser coils, two speed compressors, and variable speed, direct drive blowers. Compressor and supply air speeds adjust to system demand.

Availability of units and options varies by brand.

Requirements

See FIGURE 1 for unit clearances.

The LDT unit is ETL/CSA certified for outdoor installations only at the clearances to combustible materials listed on unit nameplate and in FIGURE 1.

The LHT unit is ETL/CSA certified as a heat pump with cooling and with or without auxiliary electric heat for outdoor installations only at the clearances to combustible materials as listed on the unit nameplate and in FIGURE 1.

Installation of LHT/LDT units must conform with standards in National Fire Protection Association (NFPA) "Standard for Installation of Air Conditioning and Ventilating Systems NFPA No. 90A," "Standard for Installation of Residence Type Warm Air Heating and Air conditioning Systems NFPA No. 90B," local municipal building codes and manufacturer's installation instructions.

⚠ IMPORTANT

The Clean Air Act of 1990 bans the intentional venting of refrigerant (CFC's and HCFC's) as of July 1, 1992. Approved methods of recovery, recycling or reclaiming must be followed. Fines and/or incarceration may be levied for non-compliance.

⚠ WARNING



Electric shock hazard and danger of explosion. Can cause injury, death or product or property damage. Turn off gas and electrical power to unit before performing any maintenance or servicing operations on the unit. Follow lighting instructions attached to unit when putting unit back into operation and after service or maintenance.

⚠ NOTICE

Roof Damage!

This system contains both refrigerant and oil. Some rubber roofing material may absorb oil, causing the rubber to swell. Bubbles in the rubber roofing material can cause leaks. Protect the roof surface to avoid exposure to refrigerant and oil during service and installation. Failure to follow this notice could result in damage to roof surface.

UNIT CLEARANCES

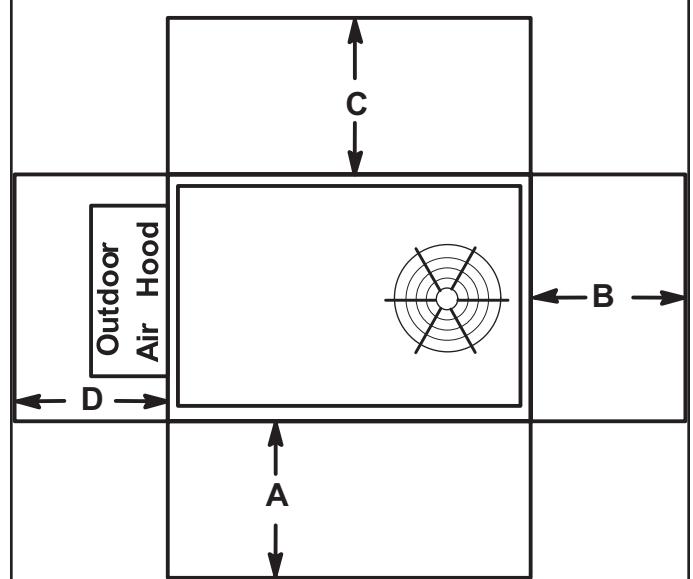

FIGURE 1

¹ Unit Clearance	A in.(mm)	B in.(mm)	C in.(mm)	D in.(mm)	Top Clearance
Service Clearance	48 (1219)	36 (914)	36 (914)	36 (914)	Unob- structed
Clearance to Combustibles	36 (914)	1 (25)	1 (25)	1 (25)	Unob- structed
Minimum Operation Clearance	36 (914)	36 (914)	36 (914)	36 (914)	Unob- structed

NOTE - Entire perimeter of unit base requires support when elevated above mounting surface.

¹ **Service Clearance** - Required for removal of serviceable parts.
Clearance to Combustibles - Required clearance to combustible material (gas units). On LCT units, see clearance to combustible materials as outlined on heater rating plate.
Minimum Operation Clearance - Required clearance for proper unit operation.

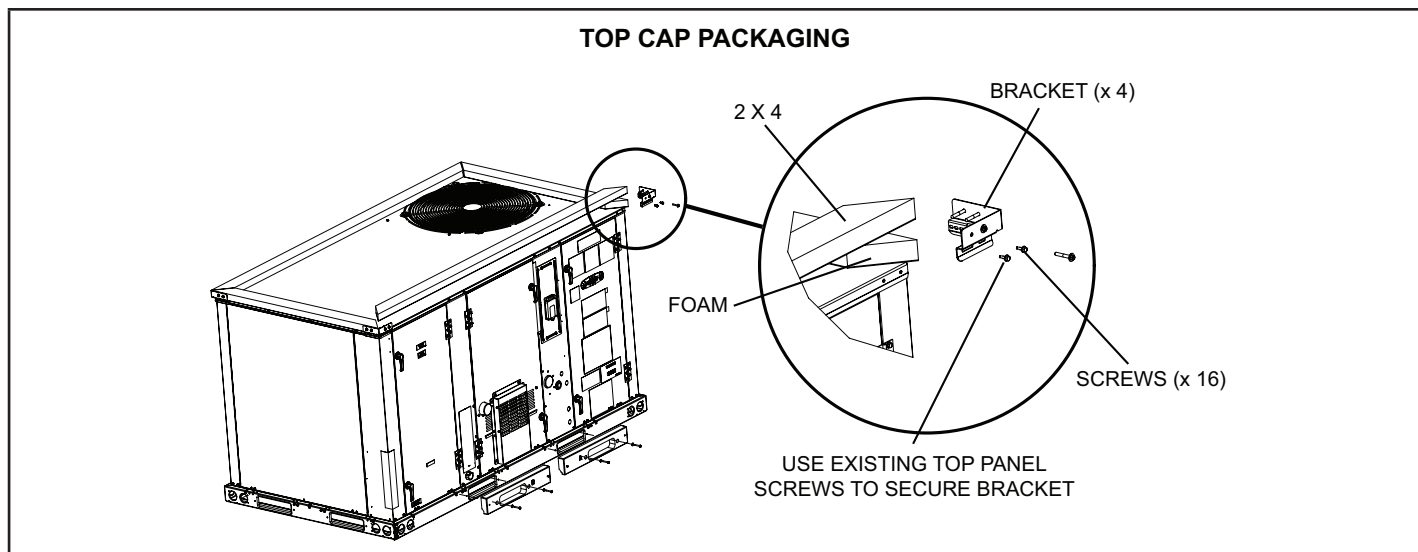

FIGURE 2

Minimum R454B Space and CFM Requirements

Minimum Airflow ¹		
Unit	Q_{min} (CFM)	Q_{min} (m ³ h)
LDT/LHT036	360	610
LDT/LHT048	369	626
LDT/LHT060	427	725
LDT/LHT072	361	612

¹ **NOTE** - The minimum airflow is the lowest CFM allowed during venting operation (leak mitigation).

Refrigerant Charge R-454B		
Unit	M_c (lbs)	M_c (kg)
LDT/LHT036	13.56	6.15
LDT/LHT048	13.94	6.32
LDT/LHT060	16.13	7.31
LDT/LHT072	13.63	6.18

Minimum Room Area of Conditioned Space ²		
Unit	TA_{min} (ft ²)	TA_{min} (m ²)
LDT/LHT036	198.68	18.46
LDT/LHT048	204.17	18.97
LDT/LHT060	236.21	21.94
LDT/LHT072	199.59	18.54

² **NOTE** - The minimum room area of conditioned space is the smallest area the unit can service.

Altitude Adjustment Factor ³									
Halt	0	200	400	600	800	1000	1200	1400	1600
AF	1	1	1	1	1.02	1.05	1.04	1.1	1.12
Halt	1600	1800	2000	2200	2400	2600	2800	3000	3200
AF	1.12	1.15	1.18	1.21	1.25	1.28	1.32	1.36	1.4

³ **NOTE** - Use the Altitude Adjustment Factor to adjust the values in the tables above to different altitudes. Find the relevant altitude above sea level in the two "Halt" rows and then multiply the value needed from the tables above by the altitude factor number. Example: For the minimum airflow in CFM for an LDT/LHT036 at 1000 ft. above sea level, multiply 360 by 1.05 to get 378 CFM as the new Q_{min} .

Use of this unit as a construction heater or air conditioner is not recommended during any phase of construction. Very low return air temperatures, harmful vapors and operation of the unit with clogged or misplaced filters will damage the unit.

If this unit has been used for heating or cooling of buildings or structures under construction, the following conditions must be met or the warranty will be void:

- A room thermostat must control the unit. The use of fixed jumpers that will provide continuous heating or cooling is not allowed.
- A pre-filter must be installed at the entry to the return air duct.
- The return air duct must be provided and sealed to the unit.
- Return air temperature range between 55°F (13°C) and 80°F (27°C) must be maintained.
- Air filters must be replaced and pre-filters must be removed upon construction completion.
- The input rate and temperature rise must be set per the unit rating plate.
- The heat exchanger, components, duct system, air filters and evaporator coil must be thoroughly cleaned following final construction clean-up.
- The unit operating conditions (including airflow, cooling operation, ignition, input rate, temperature rise and venting) must be verified according to these installation instructions.

This appliance is not intended for use by persons (including children) with reduced physical, sensory, or mental capabilities, or lack of experience and knowledge, unless they have been given supervision or instruction concerning use of the appliance by a person responsible for their safety.

Unit Support

In downflow discharge installations, install the unit on a non-combustible surface only. Unit may be installed on combustible surfaces when used in horizontal discharge applications or in downflow discharge applications when installed on an T1CURB / C1CURB / E1CURB roof mounting frame.

NOTE - Securely fasten roof frame to roof per local codes.

CAUTION

To reduce the likelihood of supply / return air by pass and promote a proper seal with the RTU, duct work / duct drops / diffuser assemblies must be supported independently to the building structure.

A-Downflow Discharge Application

Roof Mounting with T1CURB / C1CURB / E1CURB

- 1 - The roof mounting frame must be installed, flashed and sealed in accordance with the instructions provided with the frame.
- 2 - The roof mounting frame should be square and level to 1/16" per linear foot (5mm per linear meter) in any direction.
- 3 - Duct must be attached to the roof mounting frame and not to the unit; supply and return plenums must be installed before setting the unit.

Installer's Roof Mounting Frame

Many types of roof frames can be used to install the unit depending upon different roof structures. Items to keep in mind when using the building frame or supports are:

- 1 - The base is fully enclosed and insulated, so an enclosed frame is not required.
- 2 - The frames or supports must be constructed with non-combustible materials and should be square and level to 1/16" per linear foot (5mm per linear meter) in any direction.
- 3 - Frame or supports must be high enough to prevent any form of moisture from entering unit. Recommended minimum frame height is 14" (356mm).
- 4 - Duct must be attached to the roof mounting frame and not to the unit. Supply and return plenums must be installed before setting the unit.
- 5 - Units require support along all four sides of unit base. Supports must be constructed of steel or suitably treated wood materials.

NOTE - When installing a unit on a combustible surface for downflow discharge applications, a T1CURB / C1CURB / E1CURB roof mounting frame is required.

B-Horizontal Discharge Applications

- 1 - Units which are equipped with an optional economizer and installed in horizontal airflow applications must use a horizontal conversion kit.
- 2 - Specified installation clearances must be maintained when installing units. Refer to FIGURE 1.
- 3 - Top of support slab should be approximately 4" (102mm) above the finished grade and located so no run-off water from higher ground can collect around the unit.
- 4 - Units require support along all four sides of unit base. Supports must be constructed of steel or suitably treated wood materials.

Duct Connection

All exterior ducts, joints and openings in roof or building walls must be insulated and weather-proofed with flashing and sealing compounds in accordance with applicable codes. Any duct passing through an unconditioned space must be insulated.

⚠ CAUTION

In downflow applications, do not drill or punch holes in base of unit. Leaking in roof may occur if unit base is punctured.

Rigging Unit for Lifting

Rig unit for lifting by attaching four cables to holes in unit base rail. See FIGURE 3.

- 1 - Detach wooden base protection before rigging.
- 2 - Remove all six base protection brackets before setting unit.
- 3 - Connect rigging to the unit base using both holes in each corner.
- 4 - All panels must be in place for rigging.
- 5 - Place field-provided H-style pick in place just above top edge of unit. Frame must be of adequate strength and length. (H-style pick prevents damage to unit.)

Unit	*Weight	
	Lbs.	Kg.
LH	833	378
LD	881	400

*Maximum weight with all available factory-installed accessories.

LIFTING POINT SHOULD BE DIRECTLY ABOVE CENTER OF GRAVITY

IMPORTANT - ALL PANELS MUST BE IN PLACE FOR RIGGING.

CAUTION - Do not walk on unit.

FIGURE 3

Horizontal Air Discharge

Unit is shipped with panels covering the horizontal supply and return air openings. Remove horizontal covers and place over downflow openings for horizontal air discharge. See FIGURE 4. Secure in place with sheet metal screws.

Units Equipped With An Optional Economizer

- 1 - Remove the horizontal supply air cover and position over the downflow supply air opening. Secure with sheet metal screws.
- 2 - Leave the horizontal return air cover in place.
- 3 - Locate the separately ordered horizontal air discharge kit. Place the kit panel over the downflow return air opening.
- 4 - Remove and retain the barometric relief dampers and lower hood.

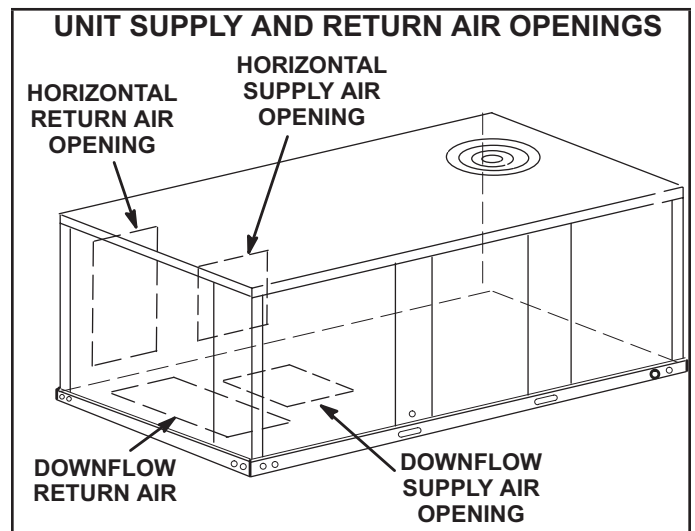

FIGURE 4

- 5 - Install return air duct beneath outdoor air intake. See FIGURE 5. Install barometric relief damper in lower hood and install in ductwork as shown in FIGURE 5.

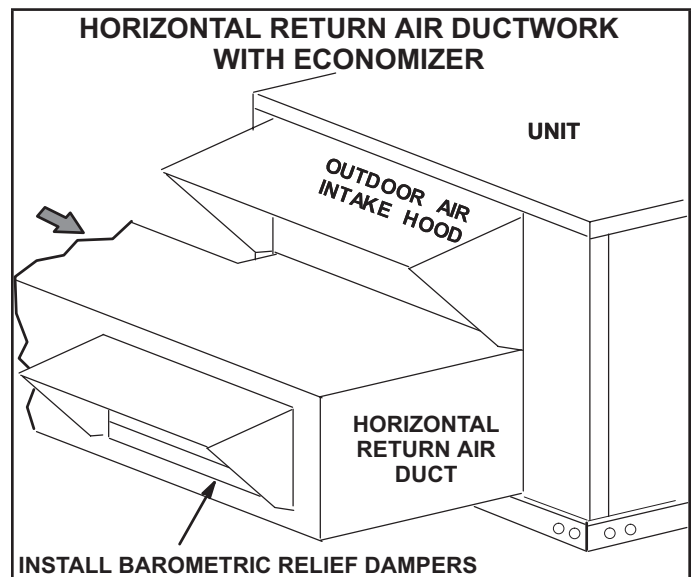

FIGURE 5

Condensate Drains

Make drain connection to the drain coupling provided on unit. Older model units have a 3/4" N.P.T. coupling and newer model units have a 1" N.P.T. coupling.

NOTE - The drain pan is made with a glass reinforced engineered plastic capable of withstanding typical joint torque but can be damaged with excessive force. Tighten pipe nipple hand tight and turn an additional quarter turn.

A trap must be installed between drain connection and an open vent for proper condensate removal. See FIGURE 6 or FIGURE 7. It is sometimes acceptable to drain condensate onto the roof or grade; however, a tee should be fitted to the trap to direct condensate downward. The condensate line must be vented. Check local codes concerning condensate disposal. Refer to page 1 and page 4 for condensate drain location.

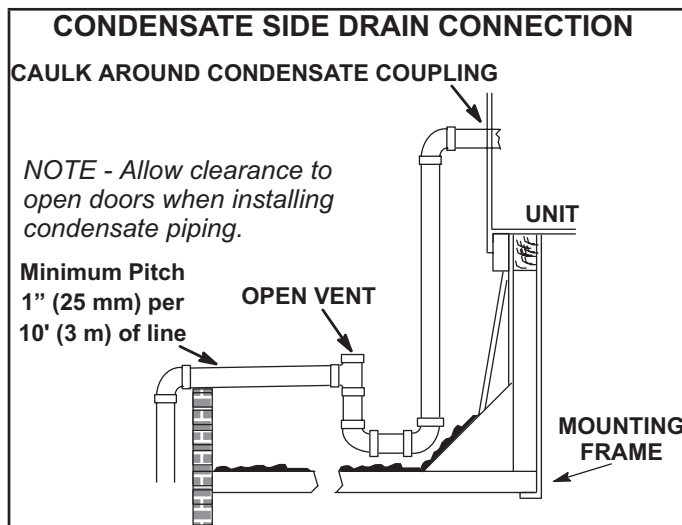

FIGURE 6

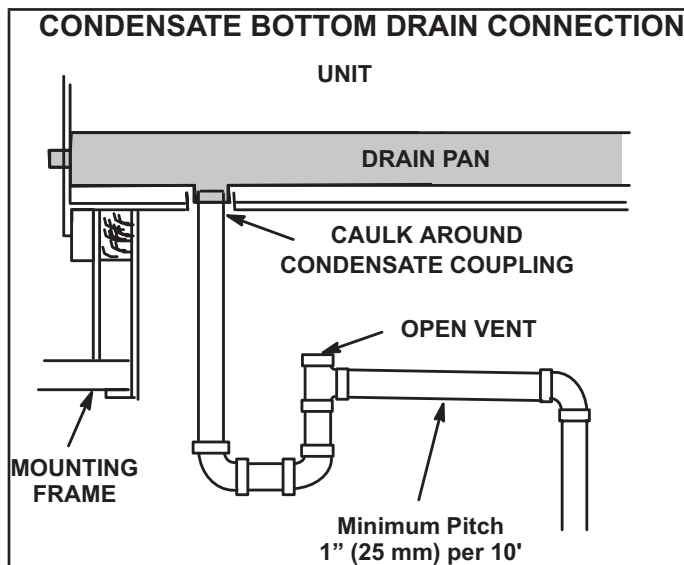

FIGURE 7

Units are shipped with the drain coupling facing the front of the unit. Condensate can be drained from the back or bottom of the unit with the following modifications. The unit can be installed in either downflow or horizontal air discharge regardless of condensate drain location.

Rear Drain Connection

- 1 - Remove the condensate drain mullion. See FIGURE 8. Remove the two panels on each side of the mullion.

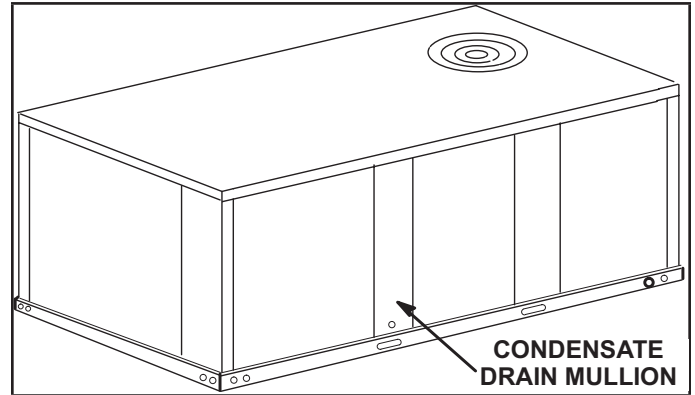

FIGURE 8

Two hinge screws must be removed in addition to the mullion screws. See FIGURE 9.

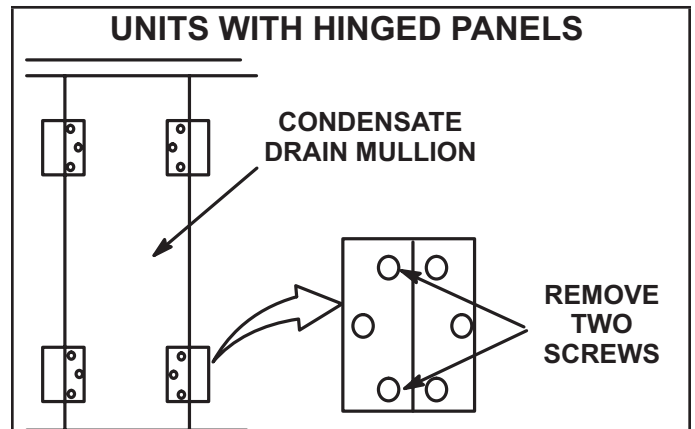

FIGURE 9

- 2 - Lift the front edge of the drain pan and slide pan out of unit. See FIGURE 10.

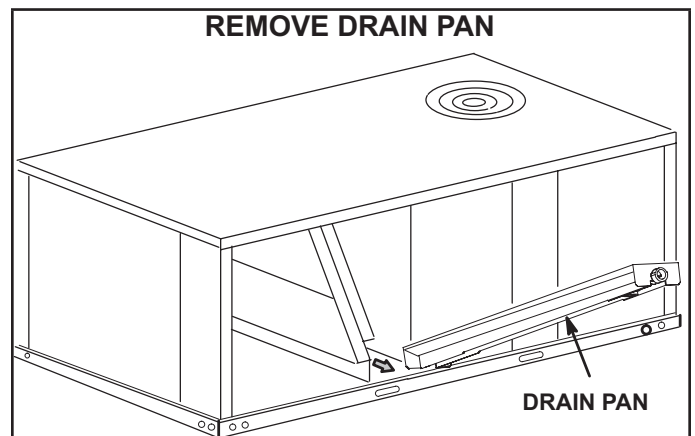

FIGURE 10

- 3 - Make sure the cap over the unit bottom drain hole is secure.
- 4 - Rotate the drain pan until the downward slope is toward the back of the unit. Slide the drain pan back into the unit. Be careful not to dislodge the cap over the bottom drain hole.
- 5 - From the back side of the unit, pull the drain pan coupling through the rear condensate opening.
- 6 - Replace the condensate drain mullion.

Bottom Drain Connection

- 1 - Remove the condensate drain mullion. See FIGURE 8.
- 2 - Lift the front edge of the drain pan and slide pan out of unit. See FIGURE 10.
- 3 - Turn the drain pan upside down and drill a pilot hole through the bottom of the drain pan in the center of the coupling. See FIGURE 11.

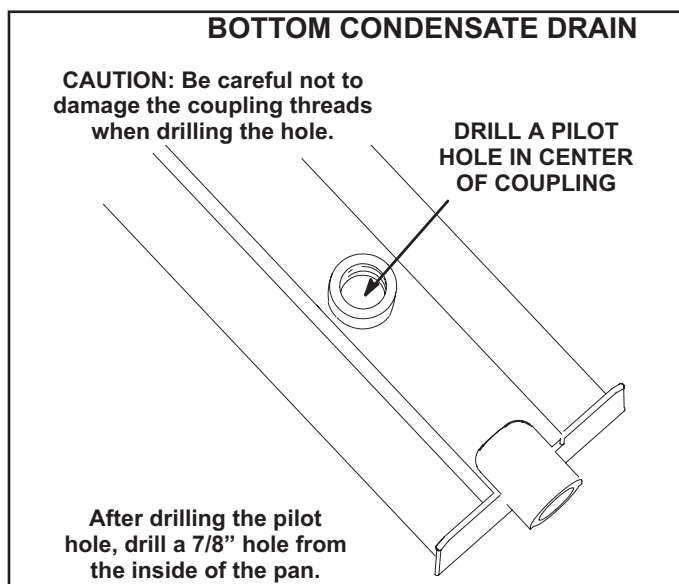

FIGURE 11

- 4 - From the inside of the pan, use a Vari-Bit® bit to enlarge the hole to 7/8". Do not damage coupling threads.
- 5 - Remove the cap over the unit bottom drain hole.
- 6 - Slide the drain pan back into the unit.
- 7 - From the back side of the unit, pull the drain pan coupling through the rear condensate opening.
- 8 - From the front side of the unit, move the drain pan until the bottom coupling settles into the unit bottom drain opening. Once in place, check to make sure the coupling is still positioned through the rear condensate drain hole.
- 9 - Use a field-provided 3/4" plug to seal side drain connection.
- 10 - Replace the condensate drain mullion.

Connect Gas Piping (Gas Units)

Before connecting field-provided piping, check with gas company or authorities having jurisdiction for local code requirements. When installing gas supply piping, length of run from gas meter must be considered in determining pipe size for 0.5" w.c. (.12kPa) maximum pressure drop. Do not use supply pipe smaller than unit gas connection. Operating pressures at the unit gas connection must be as shown in TABLE 1.

**TABLE 1
OPERATING PRESSURE AT GAS CONNECTON w.c.**

	Natural Gas		LP/Propane Gas	
	Min.	Max.	Min.	Max.
036-072	4.5	10.5	11	13

When making piping connections a drip leg should be installed on vertical pipe runs to serve as a trap for sediment or condensate. A 1/8" N.P.T. plugged tap is located on gas valve for test gauge connection. Refer to Heating Start-Up section for tap location. Install a ground joint union between the gas control manifold and the main manual shut-off valve. See FIGURE 12 for gas supply piping entering outside the unit. FIGURE 13 shows complete bottom gas entry piping.

Compounds used on threaded joints of gas piping shall be resistant to the action of liquefied petroleum gases.

Do not use Teflon® tape to seal gas piping. Use a moderate amount of pipe compound on the gas pipe only. Make sure the two end threads are bare.

! CAUTION

If a flexible gas connector is required or allowed by the authority that has jurisdiction, black iron pipe shall be installed at the gas valve and extend out side the furnace cabinet.

! WARNING

Do not exceed 600 in-lbs (50 ft.-lbs) torque when attaching the gas piping to the gas valve.

! IMPORTANT

Compounds used on threaded joints of gas piping must be resistant to the actions of liquefied petroleum gases.

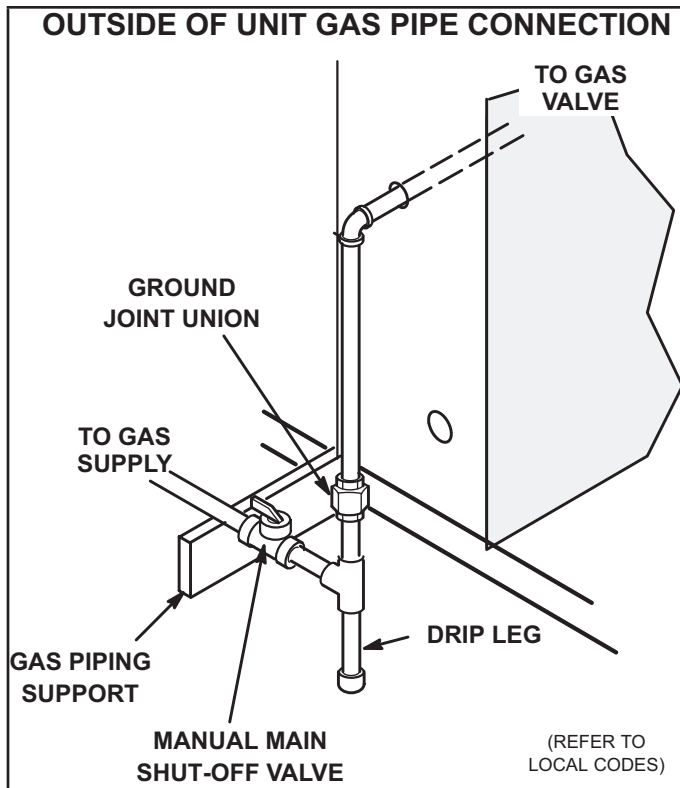

FIGURE 12

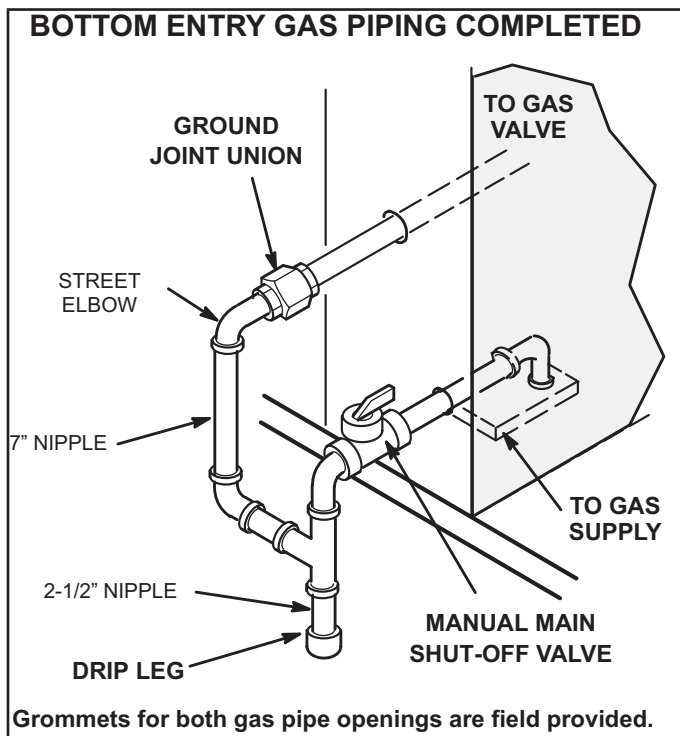

FIGURE 13

Pressure Test Gas Piping

When pressure testing gas lines, the gas valve must be disconnected and isolated. Gas valves can be damaged if subjected to more than 0.5 psig (3.48kPa). See FIGURE 14.

NOTE - Codes may require that manual main shut-off valve and union (furnished by installer) be installed in gas line external to unit. Union must be of the ground joint type.

After all connections have been made, check all piping connections for gas leaks. Also check existing unit gas connections up to the gas valve; loosening may occur during installation. Use a leak detection solution or other preferred means. Do not use matches candles or other sources of ignition to check for gas leaks.

CAUTION

Some soaps used for leak detection are corrosive to certain metals. Carefully rinse piping thoroughly after leak test has been completed. Do not use matches, candles, flame or other sources of ignition to check for gas leaks.

WARNING



Danger of explosion. Can cause injury or product or property damage. Do not use matches, candles, flame or other sources of ignition to check for leaks.

NOTE - In case emergency shut down is required, turn off the main manual shut-off valve and disconnect main power to unit. These devices should be properly labeled by the installer.

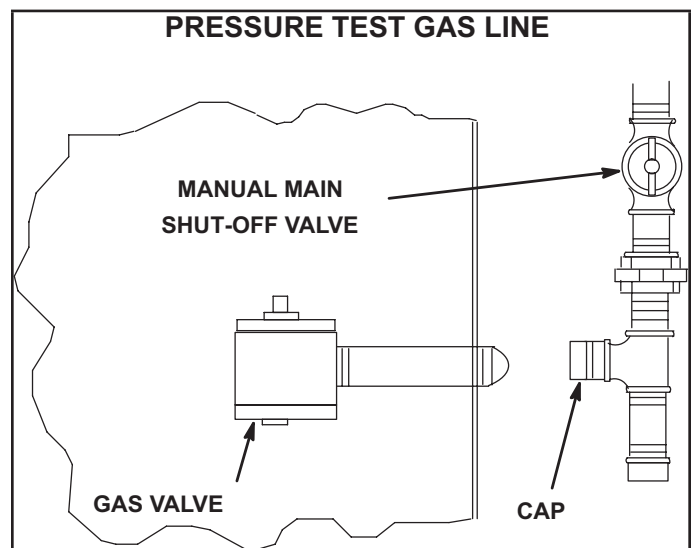

FIGURE 14

High Altitude Derate

Locate the high altitude conversion sticker in the unit literature bag. Fill out the conversion sticker and affix next to the unit nameplate. High altitude kits are available for field-installation.

Refer to TABLE 2 for high altitude adjustments.

TABLE 2
HIGH ALTITUDE DERATE

Altitude Ft.*	Gas manifold Pressure
2000-4500	See Unit Nameplate
4500 and Above	Derate 2% / 1000 Ft. above Sea Level

*Units installed at 0-2000 feet do not need to be modified.

NOTE - This is the only permissible derate for these units.

Electrical Connections - Power Supply

Do not apply power or close disconnect switch until installation is complete. Refer to start-up directions. Refer closely to unit wiring diagram.

Refer to unit nameplate for minimum circuit ampacity and maximum fuse size.

- 1 - Units are factory-wired for 230 / 460 / 575 volt supply. For 208V supply, remove the insulated terminal cover from the 208V terminal on the control transformer.

Move the wire from the transformer 240V terminal to the 208V terminal. Place the insulated terminal cover on the unused 240V terminal.

- 2 - Route power through the bottom power entry area and connect to L1, L2, and L3 on the top of K1 in control area above compressor. Secure power wiring with factory-installed wire ties provided in control box. Route power to TB2 on units equipped with electric heat. Route power to S48 or CB10 if unit is equipped with the optional disconnect switch or circuit breaker. See unit wiring diagram.

Electrical Connections - Control Wiring

NOTE - Optional wireless sensors are available for use with this unit. Refer to the instructions provided with each sensor.

CAUTION

Electrostatic discharge can affect electronic components. Take precautions during unit installation and service to protect the electronic controls. Precautions will help to avoid control exposure to electrostatic discharge by putting the unit, the control and the technician at the same electrostatic potential. Neutralize electrostatic charge by touching hands and all tools on an unpainted unit surface, such as the gas valve or blower deck, before performing any service procedure.

A-Thermostat Location

Room thermostat mounts vertically on a standard 2" X 4"

handy box or on any non-conductive flat surface.

Locate thermostat approximately 5 feet (1524mm) above the floor in an area with good air circulation at average temperature. Avoid locating the room thermostat where it might be affected by:

- drafts or dead spots behind doors and in corners
- hot or cold air from ducts
- radiant heat from sun or appliances
- concealed pipes and chimneys

B-Control Wiring

The Unit Controller will operate the unit from a thermostat or zone sensor based on the System Mode. The default System Mode is the thermostat mode. Refer to the Unit Controller Setup Guide to change the System Mode. Use the mobile service app menu and select *Settings > Install*.

Thermostat Mode

- 1 - Route thermostat cable or wires from subbase to control area above compressor (refer to unit dimensions to locate bottom and side power entry).

IMPORTANT - Unless field thermostat wires are rated for maximum unit voltage, they must be routed away from line voltage wiring. Use wire ties located near the lower left corner of the controls mounting panel to secure thermostat cable.

Use 18 AWG wire for all applications using remotely installed electro-mechanical and electronic thermostats.

- 2 - Install thermostat assembly in accordance with instructions provided with thermostat.
- 3 - Connect thermostat wiring to Unit Controller on the lower side of the controls hat section.
- 4 - Wire as shown in FIGURE 15 for electro-mechanical and electronic thermostats. If using other temperature control devices or energy management systems see instructions and wiring diagram provided by manufacturer.

IMPORTANT - Terminal connections at the wall plate or subbase must be made securely. Loose control wire connections may allow unit to operate but not with proper response to room demand.

Zone Sensor Mode

The Unit Controller will operate heating and cooling based on the Unit Controller internal setpoints and the temperature from the A2 zone sensor. An optional Network Control Panel (NCP) can also be used to provide setpoints. A thermostat or return air sensor can be used as a back-up mode. Make zone sensor wiring connections as shown in FIGURE 16.

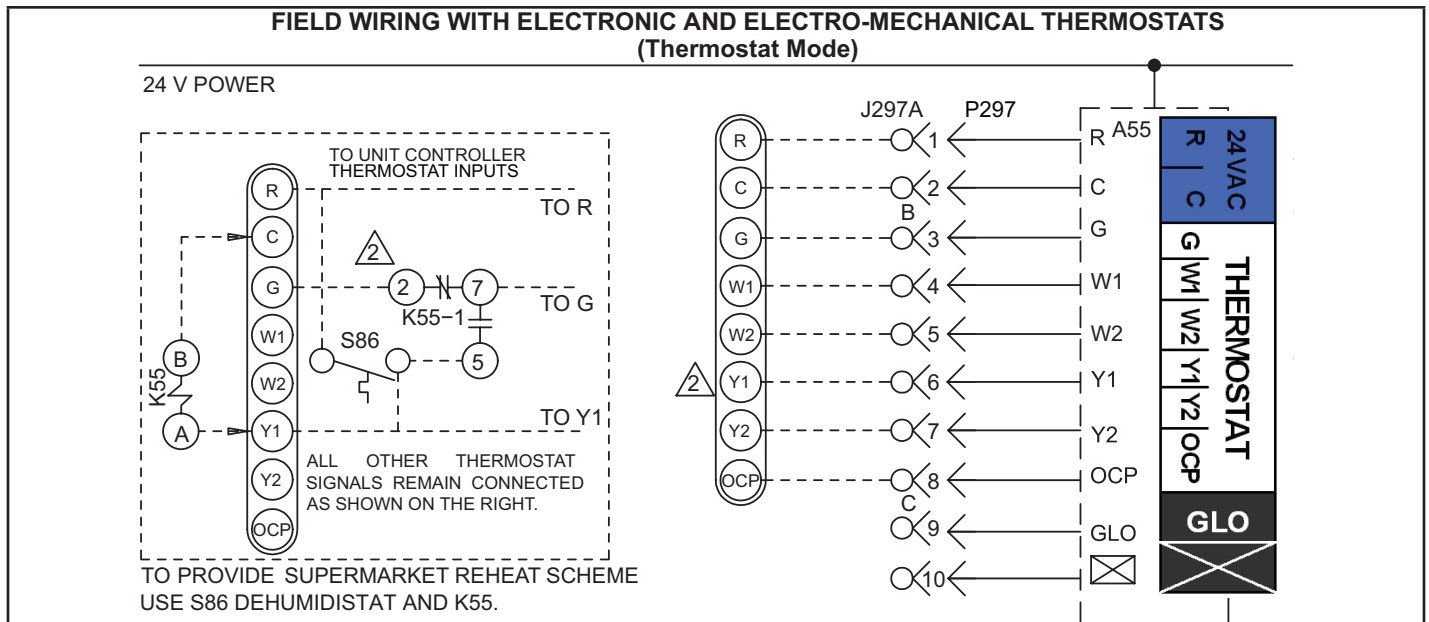

FIGURE 15

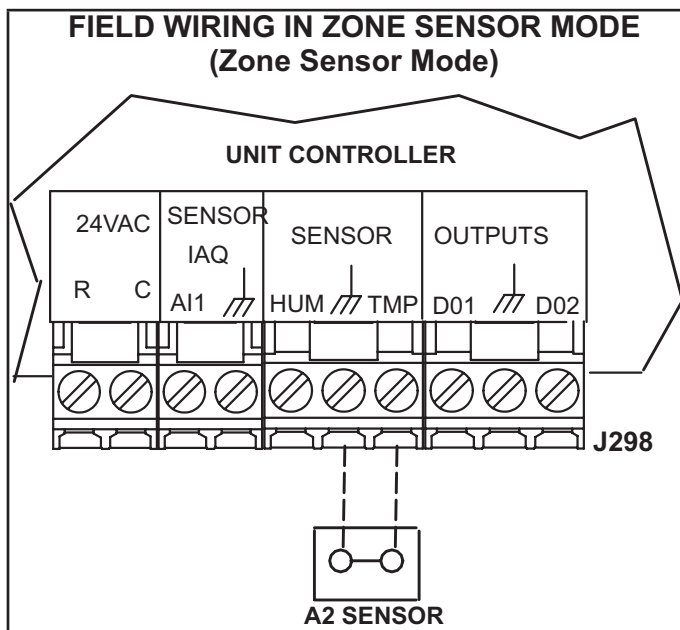

FIGURE 16

Unit Power-Up

A-General

- 1 - Make sure that unit is installed in accordance with the installation instructions and applicable codes.
- 2 - Inspect all electrical wiring, both field and factory installed, for loose connections. Tighten as required.
- 3 - Check to ensure that refrigerant lines do not rub against the cabinet or against other refrigerant lines.
- 4 - Check voltage at main unit power connection. Voltage must be within range listed on nameplate. If not, consult power company and have voltage condition corrected before starting unit.
- 5 - Make sure filters are in place before start-up.
- 6 - Make sure there is no heating, cooling, or blower demand from thermostat. Apply power to unit.

Balance Point Setpoint

When outdoor air temperature is above setpoint (35°F default), the unit will operate in heat pump mode. When outdoor air temperature falls below setpoint, the unit will operate in gas heat mode.

NOTE - Only stage one is used; stage 2 is not used.

Although the recommended balance point setpoint is 35°F, the setpoint can be adjusted. Weigh the comfort / cost benefit when increasing the setpoint.

Mobile Service App

Setup and configure each rooftop unit using the mobile service app (Android or iOS devices supported).

A-Mobile Device Requirements

- Bluetooth connection.
- Android hardware requires 2GB RAM and a 2Ghz core processor. Tablets are supported.
- The app is available for both iOS 11.0 or higher (App Store) and Android 9.0 or higher (Google Play).

B-Download the App

Use your mobile device to scan the QR code from the cover page and download the mobile service app to your mobile device.

C-Pair the App to the Unit Controller

- 1 - Apply power to the unit and wait until the Unit Controller has booted-up (approximately two minutes).
- 2 - Press and hold the pair button for five seconds. See FIGURE 18.
- 3 - The unit (or list of units) will appear; select the appropriate unit. When the app code matches the four-character code on the Unit Controller display, the unit is paired (within 10 seconds). Note the following:
 - The app will list the units by signal strength; the RTU name will be displayed.
 - Once paired, the RTU name, model number, serial number and firmware version will be displayed.

Please refer to the manufacturer's website for additional technical information and self-help support.

D-App Menus

See FIGURE 17 for the menu overview. Follow the app prompts in the Install, Network Integration, and Test and Balance menus. Verify the app is setup properly for the unit application (including the date and time). Refer to FIGURE 19, FIGURE 20, and FIGURE 21.

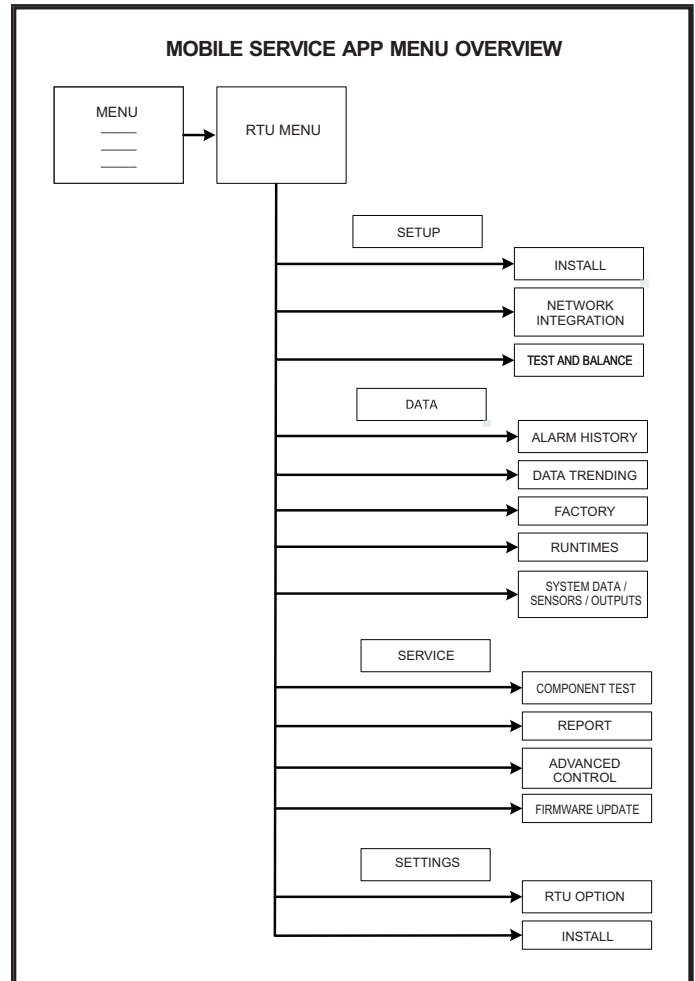

FIGURE 17

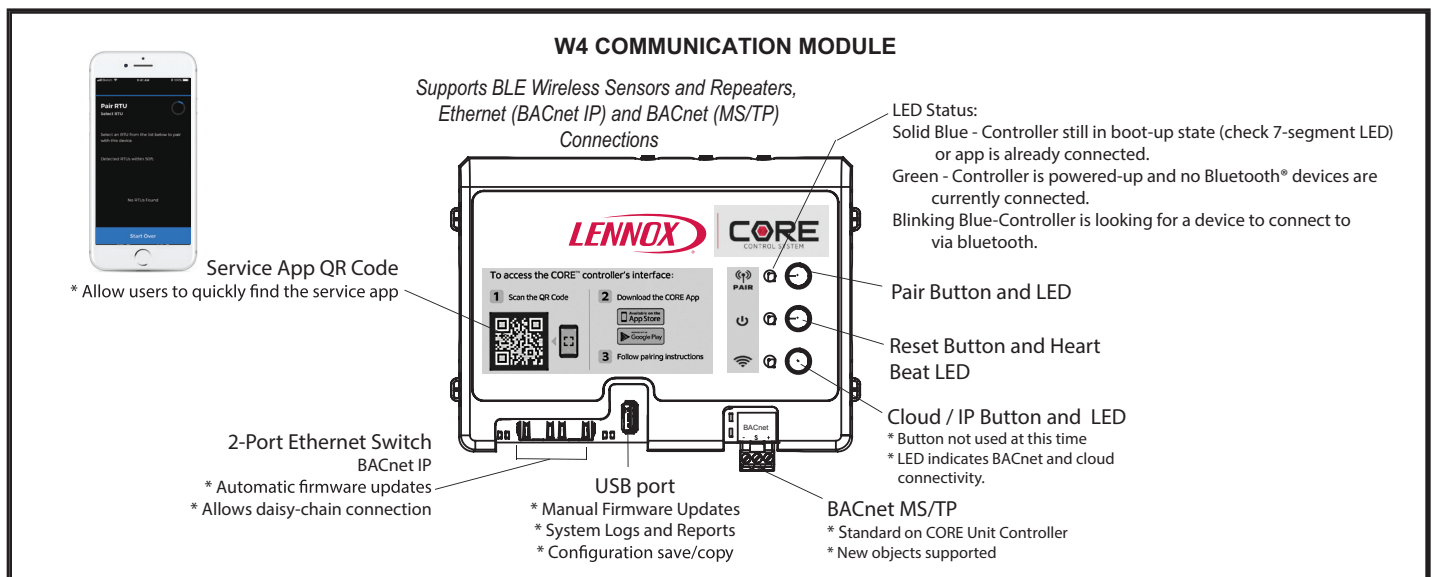

FIGURE 18

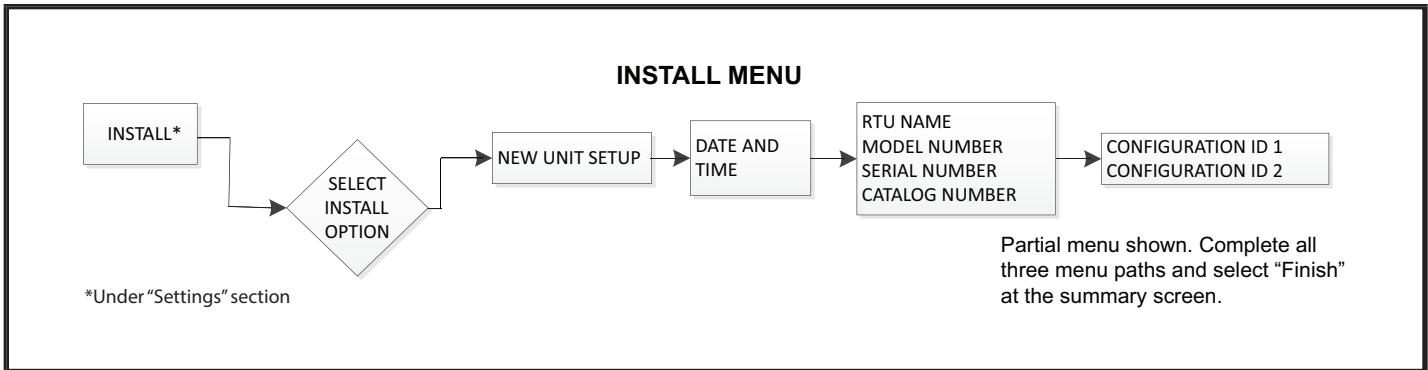

FIGURE 19

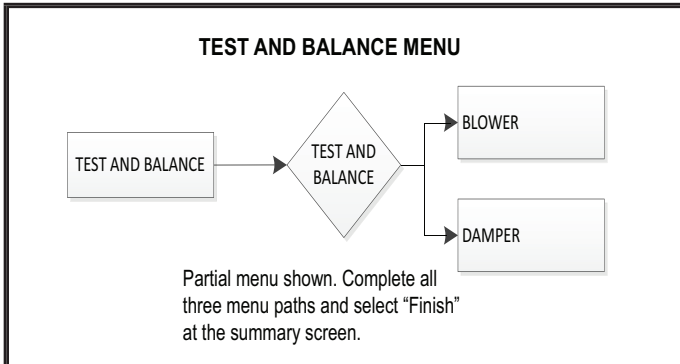

FIGURE 20

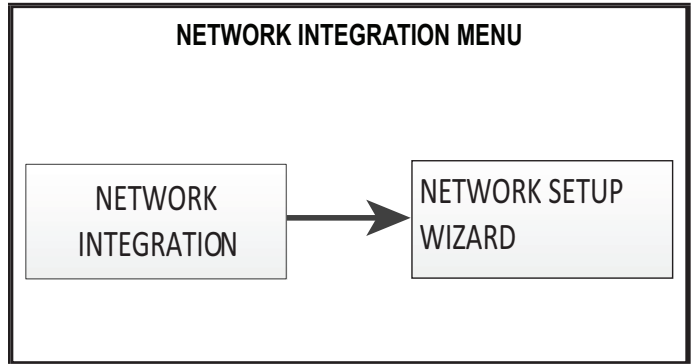

FIGURE 21

E-Unit Controller Components

See FIGURE 22 for Unit Controller components. See FIGURE 23 and TABLE 3 for pushbutton and LED functions.

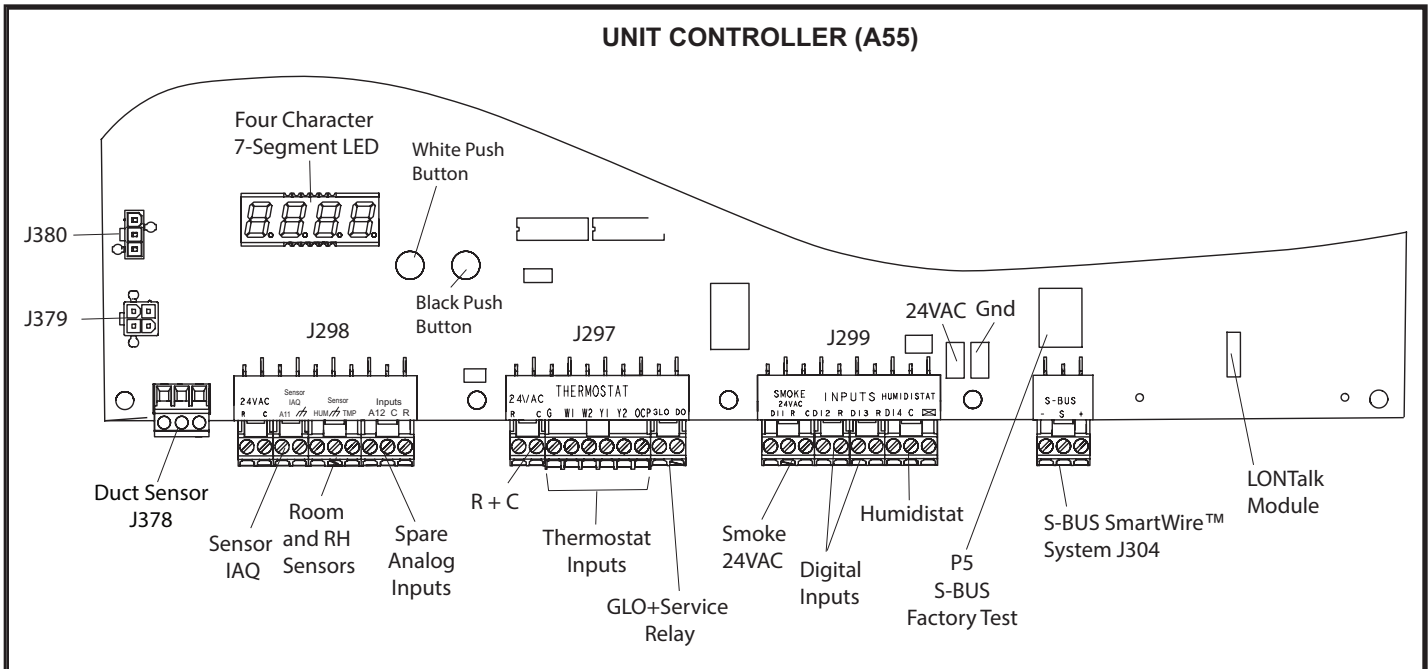

FIGURE 22

Blower Operation and Adjustments

⚠ IMPORTANT

Three phase scroll compressors must be phased sequentially for correct compressor and blower rotation. Follow "COOLING START-UP" section of installation instructions to ensure proper compressor and blower operation.

A-Blower Operation

Refer to the Unit Controller Setup Guide to energize blower. Use the mobile service app menu; see:

RTU MENU>COMPONENT TEST>BLOWER>START TEST

⚠ WARNING

- 1- Make sure that unit is installed in accordance with the installation instructions and applicable codes.
- 2- Inspect all electrical wiring, both field and factory-installed, for loose connections. Tighten as required.
- 3- Check to ensure that refrigerant lines do not rub against the cabinet or against other refrigerant lines.
- 4- Check voltage at disconnect switch. Voltage must be within range listed on nameplate. If not, consult power company and have voltage condition corrected before starting unit.
- 5- Make sure filters are new and in place before start-up.

Direct-drive motor may not immediately stop when power is interrupted to the Unit Controller. Disconnect unit power before opening the blower compartment. The Controller's digital inputs must be used to shut down the blower. See Unit Controller manual for operation sequences.

B-Determining Unit CFM

- 1 - The following measurements must be made with air filters in place.
- 2 - With all access panels in place, measure static pressure external to unit (from supply to return). Blower performance data is based on static pressure readings taken in locations shown in FIGURE 24.

NOTE - Static pressure readings can vary if not taken where shown.

- 3 - Measure the indoor blower wheel RPM.
- 4 - Referring to the Blower Data tables, use static pressure and RPM readings to determine unit CFM. Use the Accessory Air Resistance tables when installing units with any of the options or accessories listed. Refer to TABLE 4 for minimum airflow when electric heat is installed.

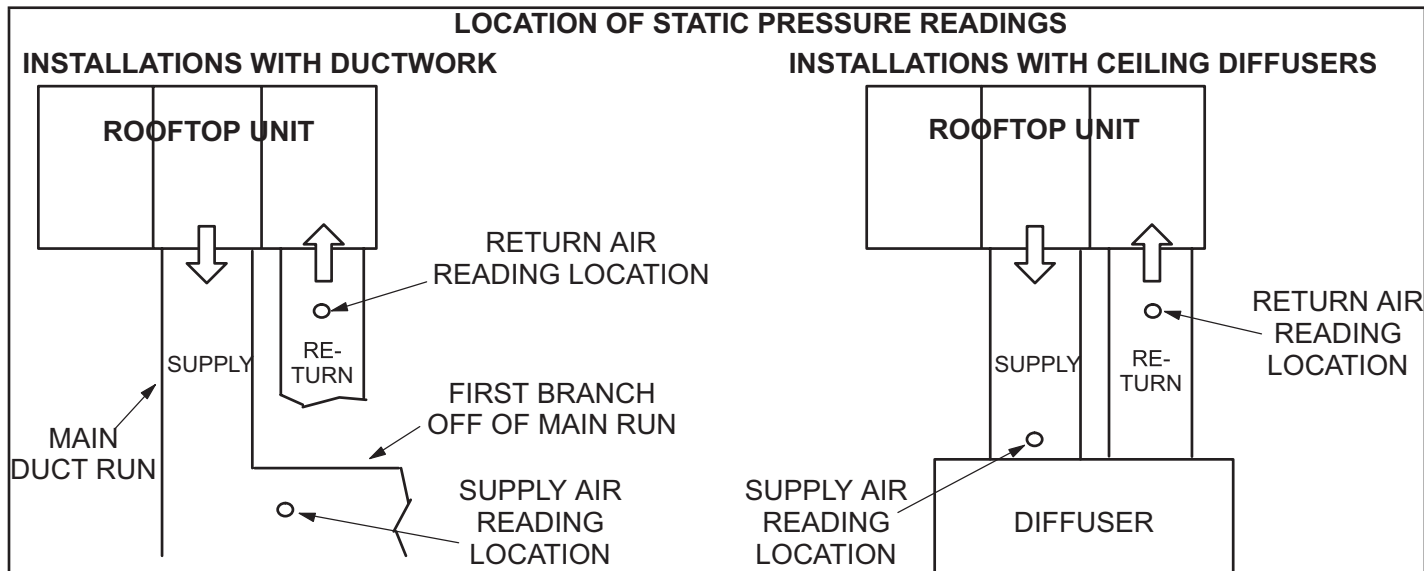

FIGURE 24

5 - From the mobile service app, use **TEST & BALANCE > BLOWER** menu to modify the following blower parameters:

- **HEATING HIGH CFM**
This is the percentage of torque for blower heating speed.
- **HEATING LOW CFM**
This is the percentage of torque for blower heating low speed on single phase gas heating units only.
- **COOLING HIGH CFM**
This is the percentage of torque for blower cooling high speed.
- **COOLING LOW CFM**
This is the percentage of torque for blower cooling low speed and vent speed for standard static blowers (all units).
- **VENTILATION CFM**
This is the percentage of torque for high static blower ventilation speed.

C-Adjusting Unit CFM

The supply CFM can be adjusted by changing Unit Controller settings. Refer to TABLE 5 for menu paths and default settings. Record any CFM changes on the parameter settings label located on the inside of the compressor access panel.

IMPORTANT - The default value for Cooling Low CFM is lower than a traditional single- or two-speed blower. If operating the unit with a 2 or 3-stage controller (2 or 3-stage thermostat, DDC controller, etc.), it is recommended to increase the Cooling Low CFM default value to a suitable level for part load cooling (typically 60% of full load CFM).

**TABLE 4
ELECTRIC HEAT MINIMUM AIRFLOW**

kW	CFM	
	Direct Drive	Direct Drive (Impeller Style)
7.5	600	1200
15	1100	1500
22.5	1600	2000

**TABLE 5
DIRECT DRIVE PARAMETER SETTINGS - 581102-01**

036-072 Parameter Settings		
Parameter	Field Setting	Description
NOTE - Any changes to Smoke CFM setting must be adjusted before the other CFM settings. Use SETTINGS > RTU OPTIONS > EDIT PARAMETERS = 12 for EBM, 6 for ECM		
BLOWER SMOKE CFM	%	Percentage of torque for blower smoke speed
SETUP > TEST & BALANCE > BLOWER		
BLOWER HEATING HIGH CFM	%	Percentage of torque for blower heating high speed.
BLOWER HEATING LOW CFM	%	Percentage of torque for blower heating low speed (P volt gas heat only).
BLOWER COOLING HIGH CFM	%	Percentage of torque for blower cooling high speed.
BLOWER COOLING LOW CFM	%	Percentage of torque for blower cooling low speed and vent speed for standard static blowers.
BLOWER VENTILATION CFM	%	Percentage of torque for high static blower ventilation speed.
SETUP > TEST & BALANCE > DAMPER		
BLOWER HIGH CFM DAMPER POS %	%	Minimum damper position for high speed blower operation. Default 0%.
BLOWER LOW CFM DAMPER POS %	%	Minimum damper position for low speed blower operation. Default 0%.
POWER EXHAUST DAMPER POS %	%	Minimum damper position for low power exhaust operation. Default 50%.
SETTINGS > RTU OPTIONS > EDIT PARAMETERS = 216		
POWER EXHAUST DEADBAND	%	Deadband % for power exhaust operation. Default 10%.
SETTINGS > RTU OPTIONS > EDIT PARAMETERS = 10 (Applies to Thermostat Mode ONLY)		
FREE COOLING STAGE-UP DELAY	%	Number of seconds to hold blower at low speed before switching to blower at high speed. Default 300 seconds.

Installer - Record any parameter changes under "Field Setting" column. Settings need to be recorded by installer for use when Unit Controller is replaced or reprogrammed.

BLOWER DATA

0.5 HP | 3 ROW (036)

BLOWER TABLE INCLUDES RESISTANCE FOR BASE UNIT ONLY WITH DRY INDOOR COIL AND AIR FILTERS IN PLACE.

FOR ALL UNITS ADD:

- 1- Any factory installed options air resistance (heat section, economizer, etc).
- 2- Any field installed accessories air resistance (duct resistance, diffuser, etc).

Minimum Air Volume Required for Different Gas Heat Sizes:

Standard Heat - 1075 cfm; Medium Heat - 1150 cfm; High Heat - 1500 cfm

See page 28 for wet coil and options/accessory air resistance data.

DOWNFLOW

External Static Pressure in. w.g.	Percentage of Total Motor Torque																											
	20%		30%		40%		50%		60%		70%		80%		90%		100%											
	Cfm	RPM	Cfm	Watts	RPM	Watts	Cfm	Watts	RPM	Watts	Cfm	Watts	RPM	Watts	Cfm	Watts	RPM	Watts	Cfm	Watts	RPM	Watts						
0	819	47	403	1006	79	463	1192	111	523	1335	152	573	1477	193	622	1580	236	661	1682	279	699	1812	353	753	1876	400	783	
0.1	723	48	485	919	82	539	1114	116	593	1264	159	637	1414	202	681	1522	246	715	1629	290	749	1767	365	797	1835	414	824	
0.2	636	51	565	840	88	613	1044	124	660	1201	169	699	1357	213	738	1470	258	769	1582	303	799	1726	380	841	1797	429	865	
0.3	557	57	641	769	96	683	981	134	725	1144	180	760	1306	226	794	1423	273	821	1540	319	848	1689	397	885	1761	446	906	
0.4	485	65	713	704	106	750	923	146	787	1091	194	818	1259	241	848	1380	289	872	1500	336	895	1653	415	929	1725	463	948	
0.5	418	73	783	644	116	815	870	158	846	1043	207	873	1215	256	900	1339	305	921	1462	353	942	1618	433	973	1689	481	991	
0.6	355	82	849	587	127	876	819	171	903	996	222	927	1173	272	950	1299	321	969	1425	370	987	1582	451	1016	1651	499	1034	
0.7	---	---	---	---	---	---	769	184	957	950	236	978	1131	287	998	1259	337	1015	1387	387	1032	1544	468	1058	1610	516	1077	
0.8	---	---	---	---	---	---	720	195	1008	904	248	1026	1088	301	1044	1218	352	1060	1347	403	1075	1503	484	1101	1565	531	1121	
0.9	---	---	---	---	---	---	670	206	1057	857	260	1073	1043	314	1088	1173	366	1102	1303	417	1116	1458	498	1142	---	---	---	
1.0	---	---	---	---	---	---	617	214	1102	806	269	1116	994	324	1130	1125	376	1144	1255	428	1157	1406	510	1184	---	---	---	
1.1	---	---	---	---	---	---	561	219	1145	751	276	1157	941	332	1169	1071	384	1183	1200	436	1196	1347	518	1225	---	---	---	
1.2	---	---	---	---	---	---	500	221	1185	691	278	1196	881	335	1207	1010	388	1221	1139	441	1234	1280	522	1265	---	---	---	
1.3	---	---	---	---	---	---	---	---	---	---	---	---	814	335	1242	942	388	1256	1069	441	1270	---	---	---	---	---	---	
1.4	---	---	---	---	---	---	---	---	---	---	---	---	738	330	1276	864	384	1291	989	437	1305	---	---	---	---	---	---	---

HORIZONTAL

External Static Pressure in. w.g.	Percentage of Total Motor Torque																										
	20%		30%		40%		50%		60%		70%		80%		90%		100%										
	Cfm	RPM	Cfm	Watts	RPM	Watts	Cfm	Watts	RPM	Watts	Cfm	Watts	RPM	Watts	Cfm	Watts	RPM	Watts	Cfm	Watts	RPM	Watts	Cfm	Watts	RPM	Watts	
0	794	45	388	970	76	454	1146	107	519	1281	149	575	1416	191	630	1522	110	678	1627	293	726	1715	351	768	1802	408	810
0.1	709	44	460	895	78	519	1080	111	577	1223	155	627	1366	199	677	1477	251	721	1588	303	764	1681	362	804	1773	420	843
0.2	630	46	531	855	82	583	1019	117	634	1169	163	679	1318	208	723	1435	262	763	1552	315	803	1648	375	841	1743	434	878
0.3	556	51	602	759	88	646	961	125	690	1117	172	730	1273	219	769	1395	274	805	1516	328	841	1615	388	877	1714	448	912
0.4	486	58	671	696	97	709	906	135	746	1068	184	781	1230	232	815	1356	288	848	1481	343	880	1582	403	914	1683	463	948
0.5	420	66	740	637	107	771	854	147	802	1021	196	831	1188	245	860	1317	301	890	1446	357	919	1549	418	951	1652	478	983
0.6	---	---	---	---	---	---	804	159	856	946	209	881	1147	259	905	1279	316	932	1410	372	958	1514	432	989	1618	492	1019
0.7	---	---	---	---	---	---	756	172	910	932	223	930	1107	273	949	1241	330	973	1374	386	996	1478	446	1026	1582	506	1055
0.8	---	---	---	---	---	---	709	185	962	888	236	978	1066	287	993	1201	344	1014	1336	400	1034	1440	460	1063	1544	519	1091
0.9	---	---	---	---	---	---	663	197	1013	844	249	1025	1025	300	1036	1161	357	1054	1296	413	1072	1399	472	1100	1502	530	1127
1.0	---	---	---	---	---	---	---	---	---	---	---	---	982	313	1078	1118	369	1094	1254	424	1109	1355	482	1136	1456	540	1163
1.1	---	---	---	---	---	---	---	---	---	---	---	---	938	323	1119	1073	379	1133	1208	434	1146	1307	491	1172	1406	548	1198
1.2	---	---	---	---	---	---	---	---	---	---	---	---	892	332	1158	1026	387	1170	1159	441	1182	1255	497	1208	1351	553	1233
1.3	---	---	---	---	---	---	---	---	---	---	---	---	843	340	1197	975	393	1207	1106	446	1216	1198	501	1242	1290	555	1268
1.4	---	---	---	---	---	---	---	---	---	---	---	---	790	344	1234	920	396	1242	1049	448	1250	1137	501	1276	1224	553	1302

BLOWER DATA

1.0 HP | 3 ROW (048)

BLOWER TABLE INCLUDES RESISTANCE FOR BASE UNIT ONLY WITH DRY INDOOR COIL AND AIR FILTERS IN PLACE.

FOR ALL UNITS ADD:

- 1- Any factory installed options air resistance (heat section, economizer, etc).
- 2- Any field installed accessories air resistance (duct resistance, diffuser, etc).

Minimum Air Volume Required for Different Gas Heat Sizes:

Standard Heat - 1075 cfm; Medium Heat - 1150 cfm; High Heat - 1500 cfm

See page 28 for wet coil and options/accessory air resistance data.

DOWNFLOW

External Static Pressure in. w.g.	Percentage of Total Motor Torque																																																																																																																																																																																																																																																																																																																																																																																																																																																																																																																																																																																																																																																																																																																																																																																																																																																																																																																																																																						
	20%			30%			40%			50%			60%			70%			80%			90%			100%																																																																																																																																																																																																																																																																																																																																																																																																																																																																																																																																																																																																																																																																																																																																																																																																																																																																																																																																														
	Cfm	RPM	Watts	Cfm	RPM	Watts	Cfm	RPM	Watts	Cfm	RPM	Watts	Cfm	RPM	Watts	Cfm	RPM	Watts	Cfm	RPM	Watts	Cfm	RPM	Watts	Cfm	RPM	Watts	Cfm	RPM	Watts	Cfm	RPM	Watts																																																																																																																																																																																																																																																																																																																																																																																																																																																																																																																																																																																																																																																																																																																																																																																																																																																																																																																																						
0	1115	124	488	1344	200	572	1573	276	655	1747	377	724	1920	477	792	2041	581	844	2161	684	896	2304	852	964	2354	936	992	1012	101	536	1253	181	614	1493	261	691	1677	366	755	1860	471	819	1990	578	868	2119	685	916	2277	860	980	2339	951	1006																																																																																																																																																																																																																																																																																																																																																																																																																																																																																																																																																																																																																																																																																																																																																																																																																																																																																																																	
0.1	926	88	584	1177	172	656	1427	256	728	1619	365	788	1811	473	848	1949	583	894	2086	693	939	2256	873	999	2328	969	1024	0.2	854	86	634	1113	173	701	1372	260	767	1572	371	823	1772	482	878	1916	595	921	2059	707	963	2240	891	1019	2319	991	1043																																																																																																																																																																																																																																																																																																																																																																																																																																																																																																																																																																																																																																																																																																																																																																																																																																																																																																																
0.3	794	91	684	1061	181	746	1328	270	807	1535	383	859	1741	496	910	1890	611	950	2038	725	989	2226	913	1042	2311	1014	1065	0.4	745	104	734	1019	195	791	1292	286	847	1504	401	895	1715	515	942	1868	631	979	2020	747	1016	2214	936	1066	2301	1039	1089																																																																																																																																																																																																																																																																																																																																																																																																																																																																																																																																																																																																																																																																																																																																																																																																																																																																																																																
0.5	704	122	785	983	215	837	1262	307	888	1478	423	932	1693	538	976	1849	654	1011	2004	770	1045	2201	960	1092	2288	1114	1144	0.6	671	145	836	954	238	883	1237	331	929	1456	447	969	1831	678	1041	1988	794	1073	2185	983	1118	2270	1085	1140																																																																																																																																																																																																																																																																																																																																																																																																																																																																																																																																																																																																																																																																																																																																																																																																																																																																																																																			
0.7	643	171	886	929	264	928	1215	357	969	1435	472	1006	1655	587	1043	1813	703	1073	1970	818	1103	2164	1005	1145	2246	1104	1168	0.8	619	199	935	907	291	973	1194	383	1010	1415	498	1043	1635	612	1076	1792	726	1104	1948	840	1132	2138	1024	1173	2212	1119	1196																																																																																																																																																																																																																																																																																																																																																																																																																																																																																																																																																																																																																																																																																																																																																																																																																																																																																																																
0.9	596	228	983	884	319	1016	1172	410	1049	1392	523	1079	1612	635	1109	1766	747	1135	1920	859	1161	2104	1038	1200	1200	1200	1200	1.0	555	255	1085	855	355	1120	1334	456	1124	1334	564	1149	1548	671	1173	1695	777	1195	1841	883	1217	2004	1050	1254	1254	1254	1254																																																																																																																																																																																																																																																																																																																																																																																																																																																																																																																																																																																																																																																																																																																																																																																																																																																																																																																
1.1	511	311	1145	911	411	1145	1334	456	1124	1334	564	1149	1548	671	1173	1695	777	1195	1841	883	1217	2004	1050	1254	1254	1254	1.2	466	366	1204	966	466	1204	1444	566	1204	1444	666	1204	1444	766	1204	1444	866	1204	1444	966	1204	1444	1066	1204	1444	1166	1204	1444	1266	1204	1444	1366	1204	1444	1466	1204	1444	1566	1204	1444	1666	1204	1444	1766	1204	1444	1866	1204	1444	1966	1204	1444	2066	1204	1444	2166	1204	1444	2266	1204	1444	2366	1204	1444	2466	1204	1444	2566	1204	1444	2666	1204	1444	2766	1204	1444	2866	1204	1444	2966	1204	1444	3066	1204	1444	3166	1204	1444	3266	1204	1444	3366	1204	1444	3466	1204	1444	3566	1204	1444	3666	1204	1444	3766	1204	1444	3866	1204	1444	3966	1204	1444	4066	1204	1444	4166	1204	1444	4266	1204	1444	4366	1204	1444	4466	1204	1444	4566	1204	1444	4666	1204	1444	4766	1204	1444	4866	1204	1444	4966	1204	1444	5066	1204	1444	5166	1204	1444	5266	1204	1444	5366	1204	1444	5466	1204	1444	5566	1204	1444	5666	1204	1444	5766	1204	1444	5866	1204	1444	5966	1204	1444	6066	1204	1444	6166	1204	1444	6266	1204	1444	6366	1204	1444	6466	1204	1444	6566	1204	1444	6666	1204	1444	6766	1204	1444	6866	1204	1444	6966	1204	1444	7066	1204	1444	7166	1204	1444	7266	1204	1444	7366	1204	1444	7466	1204	1444	7566	1204	1444	7666	1204	1444	7766	1204	1444	7866	1204	1444	7966	1204	1444	8066	1204	1444	8166	1204	1444	8266	1204	1444	8366	1204	1444	8466	1204	1444	8566	1204	1444	8666	1204	1444	8766	1204	1444	8866	1204	1444	8966	1204	1444	9066	1204	1444	9166	1204	1444	9266	1204	1444	9366	1204	1444	9466	1204	1444	9566	1204	1444	9666	1204	1444	9766	1204	1444	9866	1204	1444	9966	1204	1444	10066	1204	1444	10166	1204	1444	10266	1204	1444	10366	1204	1444	10466	1204	1444	10566	1204	1444	10666	1204	1444	10766	1204	1444	10866	1204	1444	10966	1204	1444	11066	1204	1444	11166	1204	1444	11266	1204	1444	11366	1204	1444	11466	1204	1444	11566	1204	1444	11666	1204	1444	11766	1204	1444	11866	1204	1444	11966	1204	1444	12066	1204	1444	12166	1204	1444	12266	1204	1444	12366	1204	1444	12466	1204	1444	12566	1204	1444	12666	1204	1444	12766	1204	1444	12866	1204	1444	12966	1204	1444	13066	1204	1444	13166	1204	1444	13266	1204	1444	13366	1204	1444	13466	1204	1444	13566	1204	1444	13666	1204	1444	13766	1204	1444	13866	1204	1444	13966	1204	1444	14066	1204	1444	14166	1204	1444	14266	1204	1444	14366	1204	1444	14466	1204	1444	14566	1204	1444	14666	1204	1444	14766	1204	1444	14866	1204	1444	14966	1204	1444	15066	1204	1444	15166	1204	1444	15266	1204	1444	15366	1204	1444	15466	1204	1444	15566	1204	1444	15666	1204	1444	15766	1204	1444	15866	1204	1444	15966	1204	1444	16066	1204	1444	16166	1204	1444	16266	1204	1444	16366	1204	1444	16466	1204	1444	16566	1204	1444	16666	1204	1444	16766	1204	1444	16866	1204	1444	16966	1204	1444	17066	1204	1444	17166	1204	1444	17266	1204	1444	17366	1204	1444	17466	1204	1444	17566	1204	1444	17666	1204	1444	17766	1204	1444	17866	1204	1444	17966	1204	1444	18066	1204	1444	18166	1204	1444	18266	1204	1444	18366	1204	1444	18466	1204	1444	18566	1204	1444	18666	1204	1444	18766	1204	1444	18866	1204	1444	18966	1204	1444	19066	1204	1444	19166	1204	1444	19266	1204	1444	19366	1204	1444	19466	1204	1444	19566	1204	1444	19666	1204	1444	19766	1204	1444	19866	1204	1444	19966	1204	1444	20066	1204	1444	20166	1204	1444	20266	1204	1444	20366	1204	1444	20466	1204	1444	20566	1204	1444	20666	1204	1444	20766	1204	1444	20866	1204	1444	20966	1204	1444	21066	1204	1444	21166	1204	1444	21266	1204	1444	21366	1204	1444	21466	1204	1444	21566	1204	1444	21666	1204	1444	21766	1204	1444	21866	1204	1444	21966	1204	1444	22066	1204	1444	22166	1204	1444	22266	1204	1444	22366	1204	1444	22466	1204	1444	22566	1204	1444	22666	1204	1444	22766	1204	1444	22866	1204	1444	22966	1204	1444	23066	1204	1444	23166	1204	1444	23266	1204	1444	23366	1204	1444	23466	1204	1444	23566	1204	1444	23666	1204	1444	23766	1204	1444	23866	1204	1444	23966	1204	1444	24066	1204	1444	24166	1204	1444	24266	1204	1444	24366	1204	1444	24466	1204	1444	24566	1204	1444	24666	1204	1444	24766	1204	1444	24866	1204	1444	24966	1204	1444	25066	1204	1444	25166	1204	1444	25266	1204	1444	25366	1204	1444	25466	1204	1444	25566	1204	1444	25666	1204	1444	25766	1204	1444	25866	1204	1444	25966	1204	1444	26066	1204	1444	26166	1204	1444	26266	1204	1444	26366	1204	1444	26466	1204	1444	26566	1204	1444	26666	1204	1444	26766	1204	1444	26866	1204	1444	26966	1204	1444	27066	1204	1444	27166	1204	1444	27266	1204	1444	27366	1204	1444	27466	1204	1444	27566	1204	1444	27666	1204	1444	27766	1204	1444	27866	1204	1444	27966	1204	1444	28066	1204	1444	28166	1204	1444	28266	1204	1444	28366	1204	1444	28466	1204	1444	28566	1204	1444	28666	1204	1444	28766	1204	1444	28866	1204	1444	28966	1204	1444	29066	1204	1444	29166	1204	1444	29266	1204	1444	29366	1204	1444	29466	1204	1444	29566	1204	1444	29666	1204	1444	29766	1204	1444	29866	1204	1444	29966	1204	1444	30066	1204	1444	30166	1204	1444	30266	1204	1444	30366	1204	1444	30466	1204	1444	30566</

BLOWER DATA

1.0 HP | 4 ROW (060)

BLOWER TABLE INCLUDES RESISTANCE FOR BASE UNIT ONLY WITH DRY INDOOR COIL AND AIR FILTERS IN PLACE.

FOR ALL UNITS ADD:

- 1- Any factory installed options air resistance (heat section, economizer, etc).
- 2- Any field installed accessories air resistance (duct resistance, diffuser, etc).

Minimum Air Volume Required for Different Gas Heat Sizes:

Standard Heat - 1075 cfm; Medium Heat - 1150 cfm; High Heat - 1500 cfm

See page 28 for wet coil and options/accessory air resistance data.

DOWNFLOW

External Static Pressure in. w.g.	Percentage of Total Motor Torque																														
	20%			30%			40%			50%			60%			70%			80%			90%			100%						
	Cfm	RPM	Watts	Cfm	RPM	Watts	Cfm	RPM	Watts	Cfm	RPM	Watts	Cfm	RPM	Watts	Cfm	RPM	Watts	Cfm	RPM	Watts	Cfm	RPM	Watts	Cfm	RPM	Watts	Cfm	RPM	Watts	Cfm
0	1101	120	494	1328	196	578	1555	272	662	1728	374	731	1901	475	800	2023	580	852	2145	684	903	2292	854	970	2348	942	998	1009	1031	1052	1074
0.1	1002	99	541	1241	180	620	1479	260	698	1662	366	763	1845	471	827	1976	579	876	2106	687	924	2268	865	987	2334	958	1013	1031	1052	1074	
0.2	918	88	589	1167	173	663	1416	257	736	1608	366	796	1800	475	856	1938	586	902	2076	697	947	2249	880	1006	2324	978	1031	1052	1074		
0.3	848	86	638	1106	174	706	1364	261	774	1564	373	830	1763	485	886	1907	599	929	2051	712	972	2234	899	1028	2316	1000	1052	1074			
0.4	790	92	688	1056	183	751	1321	273	814	1527	387	866	1733	501	918	1882	617	958	2031	732	998	2221	921	1051	2307	1024	1074				
0.5	742	105	738	1015	197	796	1287	289	854	1498	405	902	1709	520	950	1862	637	988	2014	754	1025	2208	944	1076	2296	1048	1099	1124	1151	1178	
0.6	703	124	788	981	217	841	1258	310	894	1473	427	939	1688	543	984	1843	660	1019	1998	777	1053	2194	968	1101	2281	1071	1124	1151	1178		
0.7	670	146	838	952	240	887	1233	334	935	1451	451	976	1668	568	1017	1826	685	1050	1982	801	1082	2177	991	1128	2260	1092	1151	1178	1205	1232	
0.8	642	172	888	927	266	932	1211	360	975	1431	477	1013	1650	593	1051	1807	709	1081	1963	825	1111	2155	1012	1155	2233	1109	1178	1205	1232		
0.9	618	200	937	904	294	976	1190	387	1015	1410	502	1050	1629	617	1084	1785	732	1112	1940	846	1140	2127	1029	1182	1251	1304	1331	1358	1385		
1.0	595	229	985	882	321	1020	1168	413	1054	1387	526	1086	1605	639	1117	1758	752	1143	1911	864	1169	2090	1042	1209	1278	1331	1358	1385	1412		
1.1	572	258	1034	859	349	1067	1144	437	1092	1360	548	1120	1576	659	1148	1725	769	1173	1874	878	1197	2043	1049	1236	1305	1358	1385	1412	1439		
1.2	550	287	1082	836	377	1108	1129	458	1129	1328	566	1154	1540	674	1179	1685	780	1202	1829	886	1225	1985	1049	1262	1331	1385	1412	1439	1466		
1.3	528	316	1130	813	405	1153	1080	475	1163	1288	579	1186	1496	683	1208	1634	785	1230	1772	887	1251	1913	1042	1288	1357	1412	1439	1466	1493		
1.4	506	345	1178	790	433	1201	1037	487	1196	1239	587	1216	1441	686	1236	1572	783	1256	1703	880	1275	1826	1042	1312	1381	1436	1463	1490	1517		

HORIZONTAL

External Static Pressure in. w.g.	Percentage of Total Motor Torque																														
	20%			30%			40%			50%			60%			70%			80%			90%			100%						
	Cfm	RPM	Watts	Cfm	RPM	Watts	Cfm	RPM	Watts	Cfm	RPM	Watts	Cfm	RPM	Watts	Cfm	RPM	Watts	Cfm	RPM	Watts	Cfm	RPM	Watts	Cfm	RPM	Watts	Cfm	RPM	Watts	Cfm
0	1077	113	502	1282	175	585	1486	237	668	1670	363	746	1854	489	823	1993	623	884	2131	757	944	2216	882	995	2268	926	1009	1026	1043	1060	
0.1	1016	109	546	1227	172	624	1437	234	701	1626	361	775	1814	488	848	1956	623	906	2098	757	964	2194	887	1011	2242	928	1026	1043	1060	1077	
0.2	962	111	591	1177	174	663	1392	236	735	1585	364	805	1777	492	874	1923	627	930	2069	762	985	2175	895	1029	2218	935	1044	1061	1078		
0.3	913	118	636	1133	181	703	1352	244	770	1548	372	836	1744	500	902	1893	636	955	2042	772	1007	2157	907	1048	2196	945	1063	1080	1097		
0.4	868	130	682	1092	193	744	1315	256	806	1515	384	868	1714	512	930	1866	648	980	2018	784	1030	2139	922	1069	2166	972	1090	1107	1124		
0.5	827	146	728	1054	209	785	1281	271	842	1484	399	901	1687	526	959	1841	663	1007	1995	799	1054	2121	938	1090	2193	980	1097	1114	1131		
0.6	789	165	775	1019	227	827	1249	288	879	1455	416	934	1660	543	988	1816	679	1034	1972	815	1079	2102	955	1113	2169	989	1100	1117	1134		
0.7	752	185	821	986	247	869	1219	308	916	1427	435	967	1634	562	1018	1792	698	1061	1949	833	1104	2081	972	1136	2144	1000	1107	1124	1141		
0.8	718	208	867	954	268	910	1189	328	953	1399	455	1000	1608	581	1047	1767	716	1088	1925	851	1129	2058	989	1160	2121	1000	1107	1124	1141		
0.9	684	231	913	922	290	951	1160	349	989	1371	475	1033	1581	600	1077	1741	734	1116	1900	868	1154	2031	1004	1185	2100	1000	1107	1124	1141		
1.0	650	254	960	899	313	1000	1129	369	1025	1341	494	1066	1553	618	1106	1713	751	1143	1872	884	1179	2001	1017	1209	2071	1000	1107	1124	1141		
1.1	616	277	1007	878	337	1048	1097	388	1060	1310	511	1098	1522	634	1135	1682	766	1170	1841	898	1204	1966	1028	1233	2042	1000	1107	1124	1141		
1.2	582	300	1054	857	361	1095	1063	405	1095	1276	527	1129	1488	648	1163	1647	779	1196	1806	909	1228	1925	1034	1257	2013	1000	1107	1124	1141		
1.3	548	324	1101	836	385	1142	1026	420	1128	1239	540	1159	1451	659	1190	1609	788	1221	1767	917	1252	1879	1036	1281	2000	1000	1107	1124	1141		
1.4	514	347	1148	815	409	1189	985	431	1160	1197	548	1188	1409	665	1216	1566	793	1245	1723	920	1274	1825	1033	1304	2000	1000	1107	1124	1141		

BLOWER DATA

1.5 HP | 3 ROW (036, 048)

BLOWER TABLE INCLUDES RESISTANCE FOR BASE UNIT ONLY WITH DRY INDOOR COIL AND AIR FILTERS IN PLACE.

See page 28 for wet coil and options/accessory air resistance data.

DOWNFLOW

Total Air cfm	Total Static Pressure - in. w.c.																									
	0.1		0.2		0.3		0.4		0.5		0.6		0.7		0.8		0.9		1.0		1.1		1.2		1.3	
	RPM	Watts	RPM	Watts	RPM	Watts	RPM	Watts	RPM	Watts	RPM	Watts	RPM	Watts	RPM	Watts	RPM	Watts	RPM	Watts	RPM	Watts	RPM	Watts	RPM	Watts
400	718	19	803	41	878	60	---	---	---	---	---	---	---	---	---	---	---	---	---	---	---	---	---	---	---	---
600	845	50	929	72	1008	92	1080	111	1149	127	1226	129	1307	126	1386	124	---	---	---	---	---	---	---	---	---	---
800	971	79	1057	101	1138	123	1214	143	1286	160	1362	168	1439	173	1510	181	1574	197	1630	220	1681	250	1731	279	1779	307
1000	1136	113	1215	135	1293	157	1367	177	1438	196	1510	209	1579	222	1642	239	1697	263	1747	293	1796	324	1844	353	1890	379
1200	1335	151	1406	172	1476	193	1544	213	1611	232	1675	250	1735	272	1788	299	1834	332	1878	368	1923	400	1970	428	2015	454
1400	1560	177	1617	204	1675	231	1732	257	1788	283	1841	310	1891	339	1936	371	1978	405	2019	439	2063	469	2108	496	2152	522
1600	1742	245	1792	278	1842	311	1892	344	1940	376	1988	406	2035	434	2080	461	2125	486	2169	513	2213	541	2256	570	2297	601
1800	1922	330	1970	363	2017	395	2064	426	2110	457	2155	485	2200	512	2244	539	2287	568	2328	600	2369	634	2408	671	2447	708
2000	2112	405	2158	438	2202	471	2246	503	2289	536	2331	568	2373	602	2413	640	2452	681	2490	723	2527	766	2564	809	2599	851
2200	2305	493	2347	531	2389	569	2429	608	2469	648	2508	691	2546	737	2582	784	2619	832	2654	878	2690	923	2724	965	2758	1007
2400	2499	617	2539	660	2578	704	2615	748	2652	794	2688	841	2722	890	2757	939	2791	986	2825	1031	2858	1075	2891	1117	2923	1158
2600	2697	773	2733	818	2769	864	2803	911	2837	957	2871	1005	2903	1052	2936	1099	2968	1143	3000	1186	3031	1228	3062	1270	3092	1311
2800	2896	944	2929	990	2962	1036	2993	1082	3025	1128	3056	1173	3087	1216	3118	1259	3147	1300	3177	1341	3206	1382	3236	1423	3264	1463
3000	3093	1115	3124	1160	3154	1205	3184	1249	3214	1293	3243	1335	3272	1376	3300	1416	3327	1456	3355	1495	3383	1536	3410	1576	3437	1615

Total Air cfm	Total Static Pressure - in. w.g.																							
	1.4		1.5		1.6		1.7		1.8		1.9		2.0											
	RPM	Watts	RPM	Watts	RPM	Watts	RPM	Watts	RPM	Watts	RPM	Watts	RPM	Watts										
800	1826	333	---	---	---	---	---	---	---	---	---	---	---	---										
1000	1935	403	1979	424	2021	444	2064	464	2106	485	2149	509	2191	533										
1200	2058	476	2100	498	2142	518	2184	541	2226	565	2267	592	2308	619										
1400	2194	548	2235	574	2275	601	2316	629	2356	658	2395	689	2433	720										
1600	2337	632	2377	665	2415	698	2453	733	2490	768	2527	803	2563	839										
1800	2484	746	2521	785	2557	824	2592	863	2627	902	2661	942	2695	981										
2000	2634	894	2668	935	2701	977	2735	1018	2768	1058	2802	1099	2834	1139										
2200	2790	1049	2823	1090	2855	1130	2887	1170	2919	1210	2952	1250	2984	1289										
2400	2954	1200	2986	1240	3017	1280	3048	1320	3080	1360	3111	1399	3142	1437										
2600	3123	1351	3153	1391	3184	1431	3215	1470	3245	1509	3276	1548	3306	1586										
2800	3294	1502	3323	1542	3352	1580	3382	1619	3412	1658	3442	1696	3472	1734										
3000	3464	1653	3492	1691	3520	1729	3549	1767	3578	1805	3608	1844	3638	1882										

BLOWER DATA

1.5 HP | 3 ROW (036, 048)

BLOWER TABLE INCLUDES RESISTANCE FOR BASE UNIT ONLY WITH DRY INDOOR COIL AND AIR FILTERS IN PLACE.

See page 28 for wet coil and options/accessory air resistance data.

DOWNFLOW

Total Air cfm	Total Static Pressure - in. w.c.																															
	0.1		0.2		0.3		0.4		0.5		0.6		0.7		0.8		0.9		1.0		1.1		1.2		1.3							
	RPM	Watts	RPM	Watts	RPM	Watts	RPM	Watts	RPM	Watts	RPM	Watts	RPM	Watts	RPM	Watts	RPM	Watts	RPM	Watts	RPM	Watts	RPM	Watts	RPM	Watts						
400	708	16	793	37	872	53	1000	82	1077	95	1149	107	1221	124	1365	148	1434	154	1497	163	1555	179	1607	200	1656	226	1704	254	---	---	---	
600	835	46	918	65	1000	82	1077	95	1149	107	1221	124	1365	148	1434	154	1497	163	1555	179	1607	200	1656	226	1704	254	---	---	---	---		
800	981	75	1064	92	1144	109	1221	124	1365	148	1434	154	1497	163	1555	179	1607	200	1656	226	1704	254	---	---	---	---	---	---	---	---	---	
1000	1166	105	1241	124	1315	141	1387	159	1454	176	1520	191	1582	207	1638	227	1689	252	1737	279	1783	308	1829	335	1873	362	---	---	---	---	---	
1200	1374	142	1440	162	1506	182	1569	203	1630	224	1687	246	1739	271	1787	299	1832	330	1876	361	1920	391	1964	419	2007	444	---	---	---	---	---	
1400	1591	183	1647	209	1701	235	1755	263	1806	291	1854	320	1899	351	1942	382	1984	412	2026	442	2068	469	2110	496	2153	520	---	---	---	---	---	
1600	1778	258	1827	290	1876	323	1923	355	1970	386	2015	416	2059	444	2102	470	2144	494	2185	519	2227	545	2268	572	2309	600	---	---	---	---	---	
1800	1973	352	2018	383	2063	415	2107	445	2151	476	2194	504	2237	531	2279	557	2319	584	2359	613	2397	645	2435	679	2471	713	---	---	---	---	---	
2000	2182	437	2224	468	2265	499	2306	531	2346	563	2385	596	2424	630	2461	666	2496	705	2530	745	2564	786	2598	826	2631	866	---	---	---	---	---	
2200	2388	540	2426	576	2464	613	2500	651	2536	691	2571	731	2605	774	2637	819	2668	863	2700	907	2732	949	2764	990	2795	1029	---	---	---	---	---	
2400	2589	679	2624	719	2658	761	2691	803	2724	846	2756	890	2786	935	2816	980	2846	1025	2876	1068	2907	1109	2937	1149	2967	1188	---	---	---	---	---	
2600	2787	845	2819	887	2850	930	2881	973	2911	1017	2941	1060	2970	1104	2999	1147	3028	1189	3057	1230	3087	1270	---	---	---	---	---	---	---	---	---	
2800	2983	1021	3013	1063	3042	1106	3070	1149	3099	1191	---	---	---	---	---	---	---	---	---	---	---	---	---	---	---	---	---	---	---	---	---	---

Total Air cfm	Total Static Pressure - in. w.g.													
	1.4		1.5		1.6		1.7		1.8		1.9		2.0	
	RPM	Watts	RPM	Watts	RPM	Watts	RPM	Watts	RPM	Watts	RPM	Watts	RPM	Watts
800	---	---	---	---	---	---	---	---	---	---	---	---	---	---
1000	1916	386	1957	408	1998	428	2037	447	2077	465	---	---	---	---
1200	2049	468	2089	490	2128	510	2168	529	2207	549	2246	569	2285	591
1400	2194	543	2235	565	2274	588	2313	611	2350	637	2387	664	2423	694
1600	2349	627	2387	657	2423	688	2457	722	2490	757	2522	793	2554	830
1800	2506	749	2539	787	2571	825	2602	864	2632	903	2662	942	2692	981
2000	2663	906	2694	945	2725	985	2755	1024	2785	1063	2815	1101	2845	1138
2200	2826	1068	2857	1107	2887	1146	2916	1184	2946	1221	2975	1259	3005	1296
2400	2997	1227	3027	1266	3056	1304	3085	1342	---	---	---	---	---	---
2600	---	---	---	---	---	---	---	---	---	---	---	---	---	---
2800	---	---	---	---	---	---	---	---	---	---	---	---	---	---

BLOWER DATA

1.5 HP | 4 ROW (060, 072)

BLOWER TABLE INCLUDES RESISTANCE FOR BASE UNIT ONLY WITH DRY INDOOR COIL AND AIR FILTERS IN PLACE.

See page 28 for wet coil and options/accessory air resistance data.

DOWNFLOW

Total Air cfm	Total Static Pressure - in. w.c.																									
	0.1		0.2		0.3		0.4		0.5		0.6		0.7		0.8		0.9		1.0		1.1		1.2		1.3	
	RPM	Watts	RPM	Watts	RPM	Watts	RPM	Watts	RPM	Watts	RPM	Watts	RPM	Watts	RPM	Watts	RPM	Watts	RPM	Watts	RPM	Watts	RPM	Watts	RPM	Watts
400	720	20	805	41	880	60	---	---	---	---	---	---	---	---	---	---	---	---	---	---	---	---	---	---	---	---
600	849	51	933	73	1011	93	1083	112	1152	128	1229	130	1310	126	1389	125	---	---	---	---	---	---	---	---	---	---
800	978	81	1064	103	1145	124	1220	144	1291	162	1367	170	1443	175	1514	183	1578	198	1634	222	1684	252	1734	281	1783	309
1000	1147	116	1225	138	1302	159	1376	179	1446	198	1517	211	1586	224	1648	242	1703	266	1753	296	1801	327	1849	356	1896	382
1200	1347	154	1418	175	1487	196	1555	216	1620	235	1684	253	1743	275	1795	302	1841	336	1884	373	1930	405	1976	433	2021	458
1400	1571	182	1629	209	1686	236	1742	262	1798	288	1850	315	1899	346	1943	380	1984	417	2025	453	2068	485	2113	512	2156	537
1600	1753	252	1803	286	1853	318	1902	351	1951	383	1998	415	2043	447	2087	478	2130	508	2173	539	2216	568	2259	595	2302	621
1800	1935	339	1983	371	2030	403	2076	434	2122	465	2167	495	2210	524	2253	554	2295	586	2337	618	2378	650	2418	682	2458	714
2000	2127	415	2172	448	2217	481	2260	513	2303	546	2345	579	2385	614	2425	653	2464	693	2503	734	2541	774	2578	814	2614	855
2200	2321	507	2363	545	2404	583	2444	623	2484	664	2522	707	2560	753	2596	801	2632	848	2667	895	2703	939	2737	981	2770	1023
2400	2516	635	2556	679	2594	723	2631	767	2668	813	2703	861	2737	909	2772	958	2805	1005	2839	1050	2872	1093	2905	1135	2936	1176
2600	2715	796	2751	841	2786	887	2820	933	2854	980	2887	1027	2919	1074	2952	1120	2983	1164	3015	1207	3046	1249	3077	1290	3107	1330
2800	2915	970	2947	1016	2979	1062	3011	1107	3042	1152	3073	1197	3104	1240	1282	1323	3164	1323	3193	1364	3222	1404	3251	1445	3280	1485
3000	3112	1142	3142	1187	3172	1232	3202	1276	3232	1319	3261	1361	3289	1401	3317	1441	3344	1480	3371	1520	3399	1560	3426	1600	3453	1638

Total Air cfm	Total Static Pressure - in. w.g.													
	1.4		1.5		1.6		1.7		1.8		1.9		2.0	
	RPM	Watts	RPM	Watts	RPM	Watts	RPM	Watts	RPM	Watts	RPM	Watts	RPM	Watts
800	1830	335	---	---	---	---	---	---	---	---	---	---	---	---
1000	1940	405	1983	426	2026	446	2068	466	2111	488	2154	512	2196	536
1200	2064	480	2106	501	2148	522	2190	544	2232	569	2273	595	2314	623
1400	2199	560	2241	584	2282	608	2323	634	2363	664	2402	694	2440	726
1600	2344	647	2384	675	2424	706	2462	740	2498	776	2535	811	2571	848
1800	2497	749	2533	788	2568	829	2602	872	2636	914	2671	953	2705	992
2000	2648	898	2681	941	2714	986	2746	1030	2779	1072	2812	1112	2845	1152
2200	2803	1064	2835	1105	2867	1145	2899	1186	2931	1225	2964	1265	2995	1303
2400	2968	1217	2999	1258	3031	1298	3062	1337	3093	1377	3124	1415	3156	1454
2600	3138	1371	3168	1411	3199	1450	3229	1489	3260	1528	3290	1566	3321	1604
2800	3309	1524	3338	1563	3368	1602	3398	1640	3428	1678	3458	1717	3488	1755
3000	3481	1677	3508	1715	3537	1752	3566	1790	3595	1828	3625	1866	3655	1904

BLOWER DATA

1.5 HP | 4 ROW (060, 072)

BLOWER TABLE INCLUDES RESISTANCE FOR BASE UNIT ONLY WITH DRY INDOOR COIL AND AIR FILTERS IN PLACE.

See page 28 for wet coil and options/accessory air resistance data.

DOWNFLOW

Total Air cfm	Total Static Pressure - in. w.c.																									
	0.1		0.2		0.3		0.4		0.5		0.6		0.7		0.8		0.9		1.0		1.1		1.2		1.3	
	RPM	Watts	RPM	Watts	RPM	Watts	RPM	Watts	RPM	Watts	RPM	Watts	RPM	Watts	RPM	Watts	RPM	Watts	RPM	Watts	RPM	Watts	RPM	Watts	RPM	Watts
400	711	16	796	38	---	---	---	---	---	---	---	---	---	---	---	---	---	---	---	---	---	---	---	---	---	---
600	840	47	924	66	1006	83	1083	96	1154	107	1226	109	---	---	---	---	---	---	---	---	---	---	---	---	---	---
800	990	76	1072	94	1153	111	1230	126	1301	140	1372	148	1441	155	1503	165	1560	181	1612	203	1661	229	---	---	---	---
1000	1179	108	1253	126	1326	144	1397	161	1464	178	1530	194	1590	210	1646	231	1696	255	1744	283	1790	312	1836	340	1880	365
1200	1388	146	1454	166	1519	186	1582	207	1641	228	1697	251	1749	276	1797	305	1842	336	1885	367	1929	397	1973	424	2016	450
1400	1606	189	1661	216	1715	242	1768	270	1818	298	1866	328	1911	358	1953	390	1995	420	2037	449	2079	476	2121	503	2163	527
1600	1794	268	1842	301	1890	333	1938	364	1984	396	2029	426	2073	453	2115	479	2157	503	2199	528	2240	553	2281	581	2321	609
1800	1991	364	2035	395	2079	426	2123	456	2167	486	2210	515	2252	541	2294	568	2334	596	2374	625	2412	657	2448	692	2484	727
2000	2202	451	2242	482	2283	513	2323	545	2363	577	2402	611	2440	646	2477	683	2512	722	2546	763	2579	804	2613	844	2645	884
2200	2408	559	2446	596	2483	633	2520	672	2555	712	2590	753	2623	796	2655	841	2686	885	2717	928	2748	970	2780	1010	2812	1050
2400	2609	703	2644	744	2678	786	2711	829	2744	872	2776	916	2806	961	2835	1006	2865	1050	2895	1092	2925	1133	2955	1172	2985	1212
2600	2808	874	2840	916	2871	959	2902	1003	2932	1046	2961	1090	2990	1133	3019	1176	3048	1217	3077	1257	3106	1297	3135	1336	3164	1374
2800	3006	1054	3035	1096	3064	1139	3092	1181	3121	1223	3149	1265	3177	1305	3205	1344	3234	1383	3262	1421	3290	1460	3317	1498	3345	1536
3000	3202	1228	3229	1270	3257	1312	3284	1353	3312	1394	3339	1433	3366	1472	3393	1509	3419	1547	3446	1584	3472	1622	3499	1660	3525	1698

Total Air cfm	Total Static Pressure - in. w.g.													
	1.4		1.5		1.6		1.7		1.8		1.9		2.0	
	RPM	Watts	RPM	Watts	RPM	Watts	RPM	Watts	RPM	Watts	RPM	Watts	RPM	Watts
800	---	---	---	---	---	---	---	---	---	---	---	---	---	
1000	1923	389	1964	411	2004	431	2043	450	2083	468	---	---	---	
1200	2057	473	2097	494	2136	514	2176	534	2215	553	2254	574	2293	596
1400	2205	549	2245	571	2284	594	2322	618	2360	644	2396	672	2432	702
1600	2360	637	2398	667	2434	699	2468	733	2501	768	2532	805	2563	842
1800	2519	763	2552	801	2583	840	2614	879	2644	918	2674	957	2704	995
2000	2677	924	2708	963	2739	1003	2769	1041	2799	1080	2829	1118	2859	1155
2200	2842	1089	2873	1127	2902	1166	2932	1203	2962	1241	2991	1278	3021	1315
2400	3015	1250	3044	1289	3074	1327	3103	1364	3132	1402	3162	1439	3192	1476
2600	3192	1412	3221	1450	3250	1488	3279	1525	3308	1562	3337	1599	3367	1635
2800	3372	1574	3400	1611	3428	1648	3456	1685	3485	1721	3514	1758	3543	1794
3000	3552	1735	3578	1772	3605	1808	3633	1844	3660	1880	3689	1916	3717	1952

BLOWER DATA

FACTORY INSTALLED OPTIONS/FIELD INSTALLED ACCESSORY AIR RESISTANCE - in. w.g.

Air Volume cfm	Wet Indoor Coil		Reheat Coil	Gas Heating			Economizer	Electric Heat	Filters		
	036, 048	060, 072		Standard Heat	Medium Heat	High Heat			MERV 8	MERV 13	MERV 16
800	0.01	---	0.02	0.02	0.02	0.01	0.04	0.04	0.05	0.04	0.04
1000	0.02	0.02	0.02	0.02	0.02	0.03	0.04	0.04	0.07	0.05	0.05
1200	0.03	0.04	0.02	0.02	0.02	0.06	0.04	0.04	0.07	0.05	0.05
1400	0.04	0.05	0.02	0.02	0.03	0.09	0.04	0.04	0.07	0.06	0.06
1600	0.05	0.07	0.02	0.03	0.04	0.12	0.04	0.04	0.07	0.08	0.08
1800	0.06	0.08	0.03	0.04	0.05	0.15	0.05	0.04	0.07	0.09	0.09
2000	0.08	0.10	0.03	0.04	0.06	0.18	0.05	0.05	0.08	0.10	0.10
2200	---	0.11	0.04	0.04	0.07	0.18	0.05	0.05	0.08	0.11	0.11
2400	---	0.13	0.04	0.05	0.08	0.20	0.05	0.05	0.08	0.12	0.12

POWER EXHAUST FAN PERFORMANCE

Return Air System Static Pressure in. w.g.	Air Volume Exhausted cfm
0.00	2000
0.05	1990
0.10	1924
0.15	1810
0.20	1664
0.25	1507
0.30	1350
0.35	1210

CEILING DIFFUSERS AIR RESISTANCE (in. w.g.)

Air Volume - cfm	RTD11-95S Step-Down Diffuser			FD11-95S Flush Diffuser
	2 Ends Open	1 Side & 2 Ends Open	All Ends & Sides Open	
1800	0.13	0.11	0.09	0.09
2000	0.15	0.13	0.11	0.10
2200	0.18	0.15	0.12	0.12
2400	0.21	0.18	0.15	0.14
2600	0.24	0.21	0.18	0.17
2800	0.27	0.24	0.21	0.20
3000	0.32	0.29	0.25	0.25

CEILING DIFFUSER AIR THROW DATA

Air Volume - cfm	1 Effective Throw - ft.	
	RTD11-95S	FD11-95S
2600	24 - 29	19 - 24
2800	25 - 30	20 - 28
3000	27 - 33	21 - 29

¹ Effective throw based on terminal velocities of 75 ft. per minute.

Refrigerant Leak Detection System

A-System Test

- 1 - Initiate Refrigerant Leak Detection System Test by using the following mobile service app menu path:
RTU MENU > COMPONENT TEST > LEAK DETECTION > START TEST
- 2 - Ensure that indoor blower, outdoor fan, and combustion air blower (LGT only) are energized.

Start-Up

IMPORTANT

If unit is equipped with a crankcase heater. Make sure heater is energized 24 hours before unit start-up to prevent compressor damage as a result of slugging.

A-Start-Up

Heating - LDT Units

NOTE - L1 reversing valve is de-energized in the heating mode.

- 1 - Set thermostat or temperature control device to initiate a first-stage heating demand.
- 2 - Outdoor Temperature **ABOVE** Balance Point Set-point (35°F default):
A first-stage heating demand (W1) will energize the compressor, the outdoor fan, and the blower.
A second-stage heating demand (W2) will de-energize the compressor through K27. **High gas heat** will be energized.
- 3 - Outdoor Temperature **BELOW** Balance Point Set-point (35°F default):
A first-stage heating demand (W1) will energize **low gas heat** and the blower motor.
A second-stage heating demand (W2) will energize **high gas heat**.

Heating - LHT Units

- 1 - Set thermostat or temperature control device to initiate a first-stage heating demand.
- 2 - A first-stage heating demand (W1) will energize compressor 1 and outdoor fan.

NOTE - L1 Reversing Valve is de-energized in the heating mode.

LH Units With Optional Electric Heat

An increased heating demand (W2) will energize electric heat. Electric heat is also energized during the defrost cycle to maintain discharge air temperature.

Cooling

NOTE - 024 units are single-speed cooling operation only.

- 1 - Initiate full load cooling operation using the following mobile service app menu path:

COMPONENT TEST > COOLING >

COOLING STAGE 2

- 2 - Units contain one refrigerant circuit.

NOTE - Units are equipped with two-stage compressors.

- 3 - Unit is charged with R-454B refrigerant. See unit rating plate for correct amount of charge.
- 4 - Refer to Refrigerant Charge and Check section for proper method to check refrigerant charge.

B-Three Phase Scroll Compressor Voltage Phasing

Three phase scroll compressors must be phased sequentially to ensure correct compressor and blower rotation and operation. Compressor and blower are wired in phase at the factory. Power wires are color-coded as follows: line 1-red, line 2-yellow, line 3-blue.

- 1 - Observe suction and discharge pressures and blower rotation on unit start-up.
- 2 - Suction pressure must drop, discharge pressure must rise, and blower rotation must match rotation marking.

If pressure differential is not observed or blower rotation is not correct:

- 3 - Disconnect all remote electrical power supplies.
- 4 - Reverse any two field-installed wires connected to the line side of K1 contactor. Do not reverse wires at blower contactor.

Make sure the connections are tight.

Discharge and suction pressures should operate at their normal start-up ranges.

C-Refrigerant Charge and Check - Fin/Tube Coil

WARNING - Do not exceed nameplate charge under any condition.

This unit is factory charged and should require no further adjustment. If the system requires additional refrigerant, reclaim the charge, evacuate the system, and add required nameplate charge.

Refrigerant Charge R-454B		
Unit	M _c (lbs)	M _c (kg)
LDT/LHT036	13.56	6.15
LDT/LHT048	13.94	6.32
LDT/LHT060	16.13	7.31
LDT/LHT072	13.63	6.18

In addition to conventional charging procedures, the following requirements shall be followed.

- Ensure that contamination of different refrigerants does not occur when using charging equipment. Hoses or lines shall be as short as possible to minimize the amount of refrigerant contained in them.
- Cylinders shall be kept in an appropriate position according to the instructions.
- Ensure that the unit is earth grounded prior to charging the system with refrigerant.
- Label the system when charging is complete (if not already).

- Extreme care shall be taken not to overfill the unit.

Prior to recharging the system, it shall be pressure-tested with the appropriate purging gas. The system shall be leak-tested on completion of charging but prior to commissioning. A follow up leak test shall be carried out prior to leaving the site.

- When removing refrigerant from a system, either for servicing or decommissioning, it is recommended good practice that all refrigerants are removed safely.
- When transferring refrigerant into cylinders, ensure that only appropriate refrigerant recovery cylinders are employed. Ensure that the correct number of cylinders for holding the total system charge is available. All cylinders to be used are designated for the recovered refrigerant and labelled for that refrigerant (i. e. special cylinders for the recovery of refrigerant). Cylinders shall be complete with pressure-relief valve and associated shut-off valves in good working order. Empty recovery cylinders are evacuated and, if possible, cooled before recovery
- The recovery equipment shall be in good working order with a set of instructions concerning the equipment that is at hand and shall be suitable for the recovery of all appropriate refrigerants including, when applicable, flammable refrigerants. In addition, a set of calibrated weighing scales shall be available and in good working order. Hoses shall be complete with leak-free disconnect couplings and in good condition. Before using the recovery machine, check that it is in satisfactory working order, has been properly maintained and that any associated electrical components are sealed to prevent ignition in the event of a refrigerant release. Consult manufacturer if in doubt.
- The recovered refrigerant shall be returned to the refrigerant supplier in the correct recovery cylinder, and the relevant waste transfer note arranged. Do not mix refrigerants in recovery units and especially not in cylinders.
- If compressors or compressor oils are to be removed, ensure that they have been evacuated to an acceptable level to make certain that flammable refrigerant does not remain within the lubricant. The evacuation process shall be carried out prior to returning the compressor to the suppliers. Only electric heating to the compressor body shall be employed to accelerate this process. When oil is drained from a system, it shall be carried out safely.

NOTE - System charging is not recommended below 60°F (15°C). In temperatures below 60°F (15°C), the charge must be weighed into the system.

If weighing facilities are not available, or to check the charge, use the following procedure:

- 1 - Attach gauge manifolds and operate unit in cooling mode on HIGH SPEED with economizer disabled until system stabilizes (approximately five minutes). Make

sure outdoor air dampers are closed.

NOTE - Use mobile service app menu path:

COMPONENT TEST > COOLING > COOLING STAGE 2

- 2 - Use a thermometer to accurately measure the outdoor ambient temperature.
- 3 - Apply the outdoor temperature to TABLE 6 through TABLE 8 to determine normal operating pressures. Pressures are listed for sea level applications at 80°F dry bulb and 67°F wet bulb return air.
- 4 - Compare the normal operating pressures to the pressures obtained from the gauges. Minor variations in these pressures may be expected due to differences in installations. Significant differences could mean that the system is not properly charged or that a problem exists with some component in the system. **Correct any system problems before proceeding.**
- 5 - If discharge pressure is high, remove refrigerant from the system. If discharge pressure is low, add refrigerant to the system.
 - Add or remove charge in increments.
 - Allow the system to stabilize each time refrigerant is added or removed.
- 6 - Use one of the following charge verification methods along with the normal operating pressures to confirm readings.

Charge Verification - Approach Method - AHRI Testing

- 1 - Using the same thermometer, compare liquid temperature to outdoor ambient temperature.

Approach Temperature = Liquid temperature (at condenser outlet) minus ambient temperature.
- 2 - Approach temperature should be 3.8°F +/- 1 (2.1°C +/- 0.5). An approach temperature greater than this value indicates an under-charge. An approach temperature less than this value indicates an over-charge.
- 3 - The approach method is not valid for grossly over or undercharged systems. Use TABLE 10 as a guide for typical operating pressures.

**TABLE 6 581066-02
036 NORMAL OPERATING PRESSURES**

Outdoor Coil Entering Air Temp	Discharge ± 10 psig	Suction ± 5 psig
65°F	226	137
75°F	261	139
85°F	302	141
95°F	349	143
100°F	395	145
115°F	460	148

**TABLE 7 581067-02
048 NORMAL OPERATING PRESSURES**

Outdoor Coil Entering Air Temp	Discharge ± 10 psig	Suction ± 5 psig
65°F	235	126
75°F	272	127
85°F	314	129
95°F	359	130
100°F	401	132
115°F	456	135

**TABLE 8 581068-02
060 NORMAL OPERATING PRESSURES**

Outdoor Coil Entering Air Temp	Discharge ± 10 psig	Suction ± 5 psig
65°F	244	124
75°F	287	132
85°F	330	135
95°F	377	137
100°F	430	140
115°F	491	143

**TABLE 9 581240-01
072 NORMAL OPERATING PRESSURES**

Outdoor Coil Entering Air Temp	Discharge ± 10 psig	Suction ± 5 psig
65°F	258	125
75°F	299	128
85°F	342	130
95°F	387	133
100°F	444	135
115°F	498	137

**TABLE 10
SUBCOOLING TEMPERATURE**

Unit	Outdoor Coil Entering Temp	Subcooling Temp
036	95°F	8.5°F ± 1 (4.7°C ± 0.5)
048	95°F	8.4°F ± 1 (4.7°C ± 0.5)
060	95°F	9.6°F ± 1 (5.3°C ± 0.5)
072	95°F	6.8°F ± 1 (3.8°C ± 0.5)

C-Compressor Controls

See unit wiring diagram to determine which controls are used on each unit. Optional controls are identified on wiring diagrams by arrows at junction points.

1 - High Pressure Switch (S4)

The compressor circuit is protected by a high pressure switch which opens at 640 psig ± 10 psig (4413 kPa ± 70 kPa) and automatically resets at 475 psig ± 20 psig (3275kPa ± 138 kPa).

2 - Low Pressure Switch (S87)

The compressor circuit is protected by a loss of charge switch. Switch opens at 40 psig ± 5 psig (276 ± 34 kPa) and automatically resets at 90 psig ± 5 psig (621 kPa ± 34 kPa).

3 - Diagnostics Sensors (RT46, RT48)

Two thermistors are located on specific points in the refrigeration circuit. The thermistors provide constant temperature feedback to the Unit Controller to protect the compressor. Thermistors take the place of the freezestat and low ambient pressure switch.

4 - Defrost Controls (RT48, RT17)

Both sensors provide input to the defrost control which cycles defrost. The ambient sensor (RT17) is located on the inside of the corner mullion on the back of the outdoor coil section. The coil sensor (RT48) is located on a return bend on the front of the outdoor coil.

5 - Compressor Crankcase Heater (HR1)

Crankcase heater must be energized at all times to prevent compressor damage due to refrigerant migration. Energize crankcase heater 24 hours before unit start-up by setting thermostat so that there is no cooling demand (to prevent compressor from cycling) and apply power to unit.

Defrost Control

The defrost control ensures that the heat pump outdoor coil does not ice excessively during the heating mode. The defrost control uses input from the coil and ambient sensor to issue demand defrost controls from the Unit Controller. If the system fails to calibrate or obtain readings for demand defrost, defrost will run-time at field setting.

Low gas heat (LDT) or electric heat (optional) is energized during defrost.

Defrost Test or Forced Defrost Option

A TEST option is provided for troubleshooting. The TEST mode may be started at any time using the mobile service app. Defrost mode may be started by entering the Defrost Mode in the Component Test Menu. When defrost is started, unit will run in Defrost Mode for a maximum of 5 minutes or when the outdoor coil reaches 100°F, whichever occurs first.

Diagnostic Sensors

Units are equipped with two factory-installed thermistors (RT46 and RT48) located on different points on the refrigerant circuit.

The thermistors provide the Unit Controller with constant temperature readings of two specific locations on the refrigeration circuit. These temperatures are used as feedback in certain modes of unit operation. In addition, the Unit Controller uses these temperatures to initiate alarms such as loss of condenser or evaporator airflow and loss of charge.

Each thermistor must be specifically placed for proper unit operation and to initiate valid alarms. See TABLE 11 for proper locations.

**TABLE 11
THERMISTOR LOCATION**

Unit	Sensor Yellow	Figure
036, 048, 060, 072 Indoor Coil	RT46	FIGURE 25
048 Outdoor Coil	RT48	FIGURE 26
060, 072 Outdoor Coil	RT48	FIGURE 27

**LHT/LDT036, 048, 060, 072
EVAPORATOR COIL
RT46**

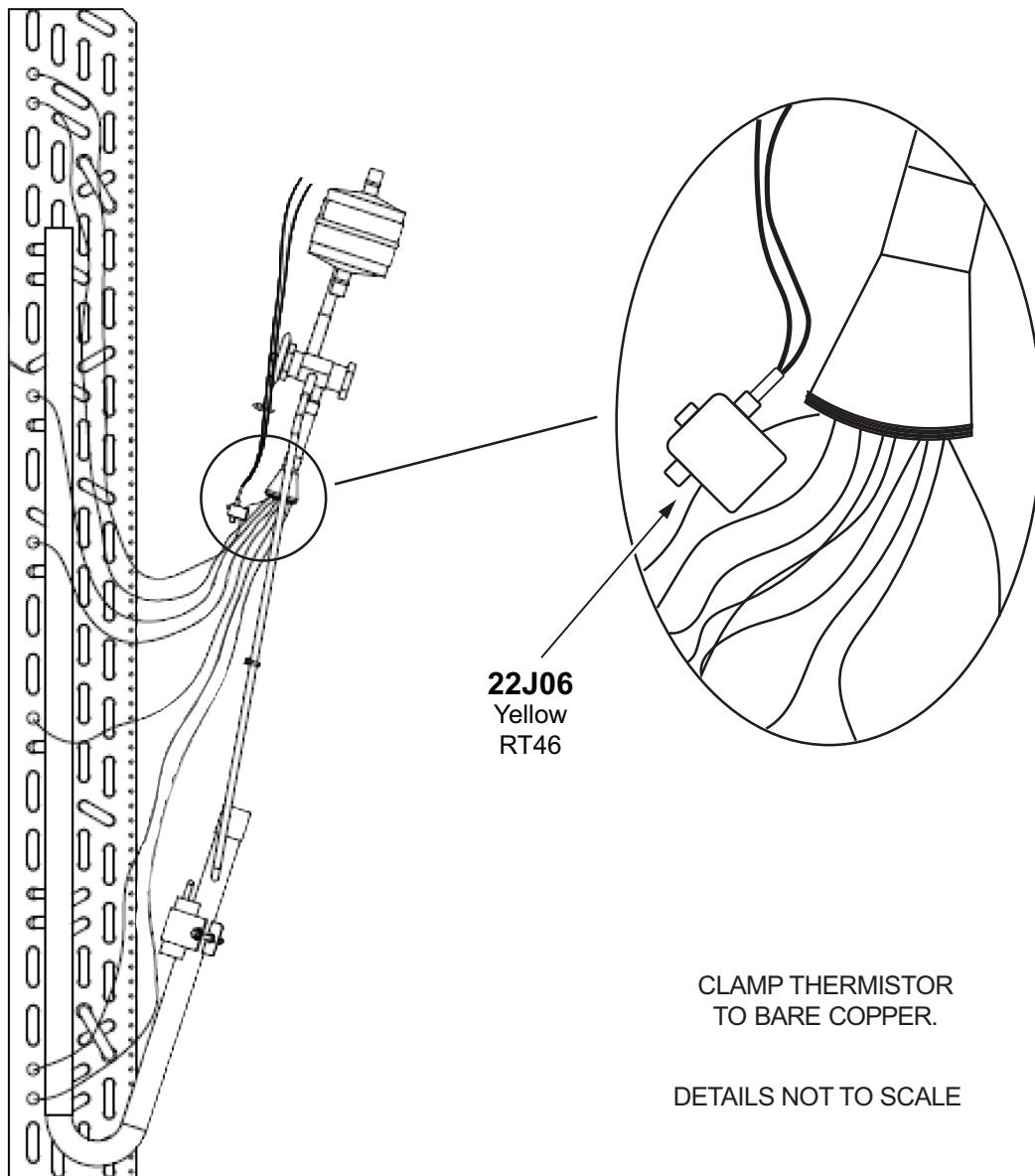
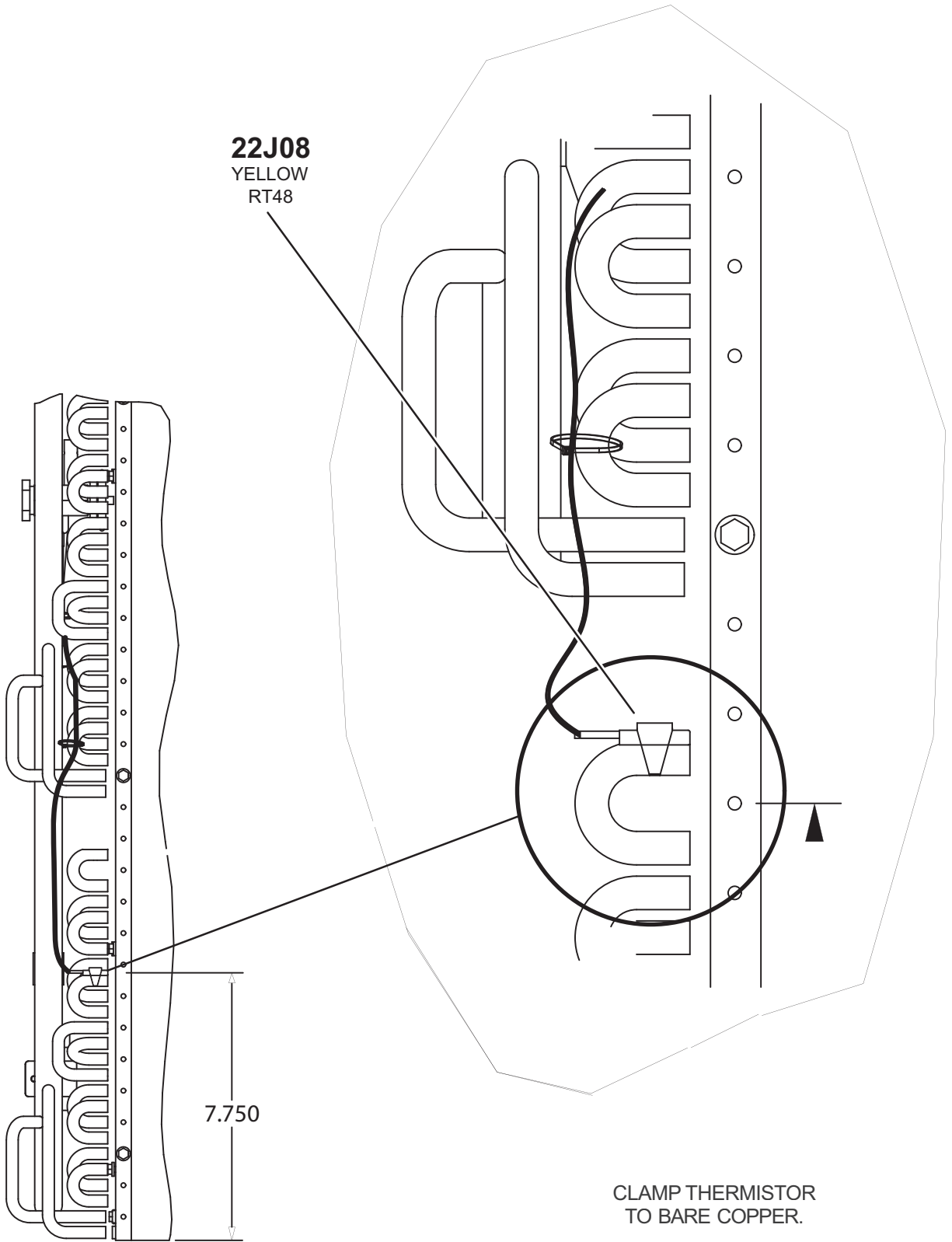

FIGURE 25

LHT/LDT036, 048
OUTDOOR COIL
RT48



22J08
YELLOW
RT48

7.750

CLAMP THERMISTOR
TO BARE COPPER.

DETAILS NOT TO SCALE

FIGURE 26

LHT/LDT060, 072
CONDENSER COIL
RT48

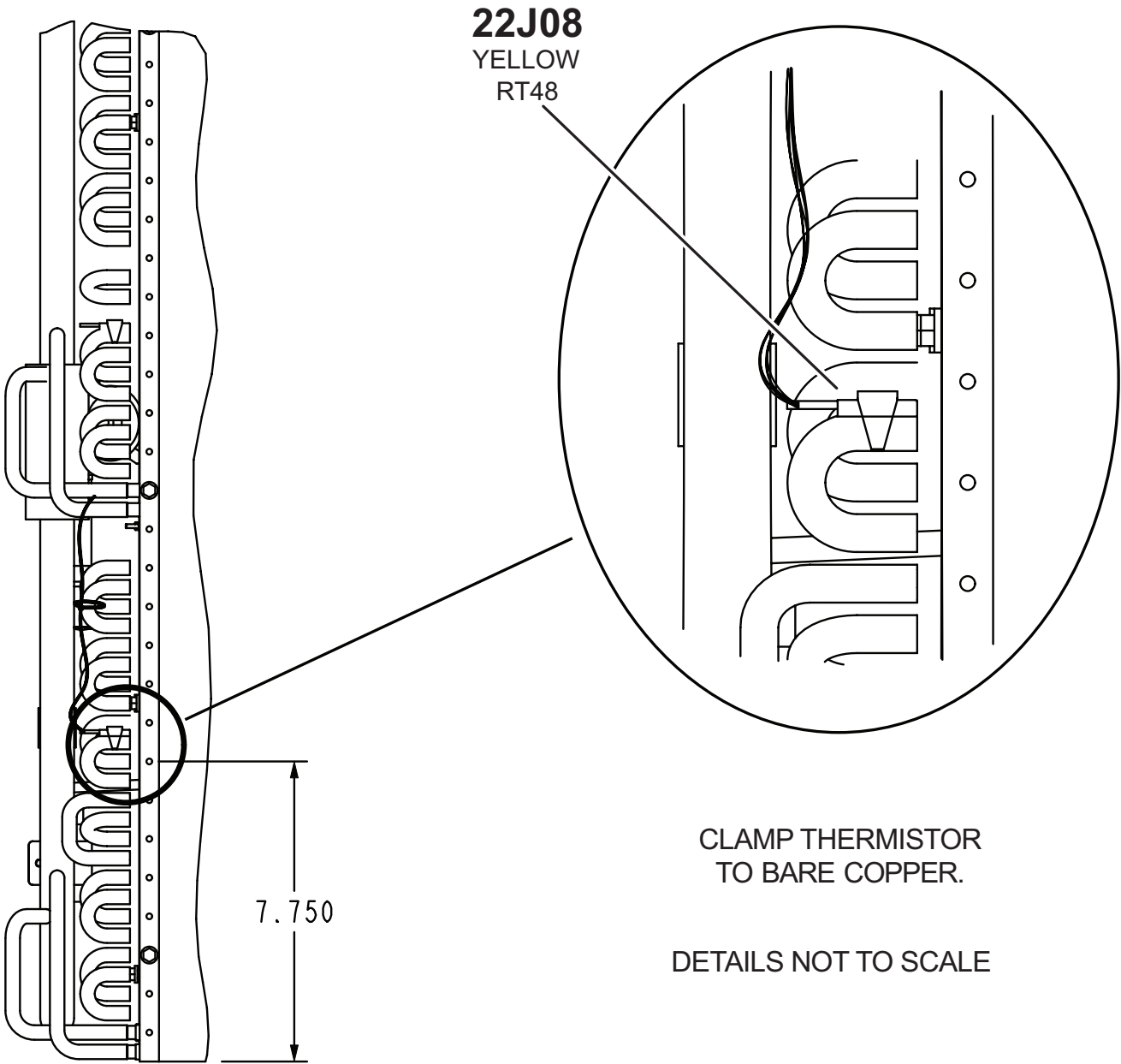

FIGURE 27

RDS Sensors

Units are equipped with factory-installed RDS Sensors located on different points on the unit. The RDS sensors provide the Unit Controller with continuous readings for leaked refrigerant concentration levels and sensor health status (Good or Fault). These readings are used to modify unit operation to disperse the leaked refrigerant and to remove possible ignition sources. In addition, the Unit Controller uses these readings to initiate alarms to alert the operator of a refrigerant leak or faulty sensor(s).

Each sensor must be specifically placed for proper unit operation and to initiate valid alarms. To identify sensor locations see TABLE 12.

TABLE 12

RDS Sensor Figures			
Model	Qty.	Type	Figure
LDT036-072	2 sensors	ID SENSOR	FIGURE 28
		COMPRESSOR SENSOR	FIGURE 29
LHT036-072	1 sensor	ID SENSOR	FIGURE 28

INDOOR COIL RDS SENSOR LOCATION

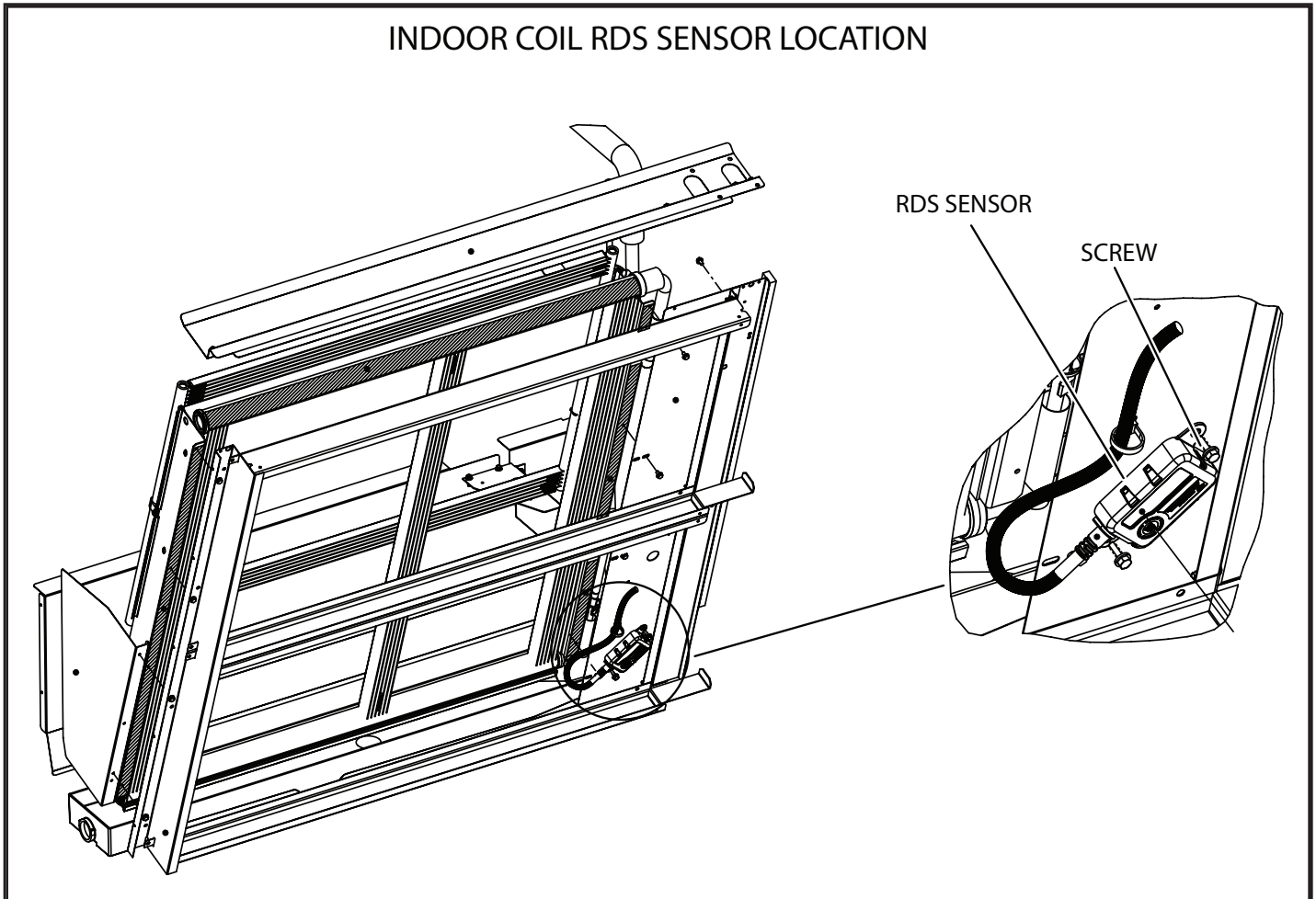

FIGURE 28

COMPRESSOR RDS SENSOR LOCATION

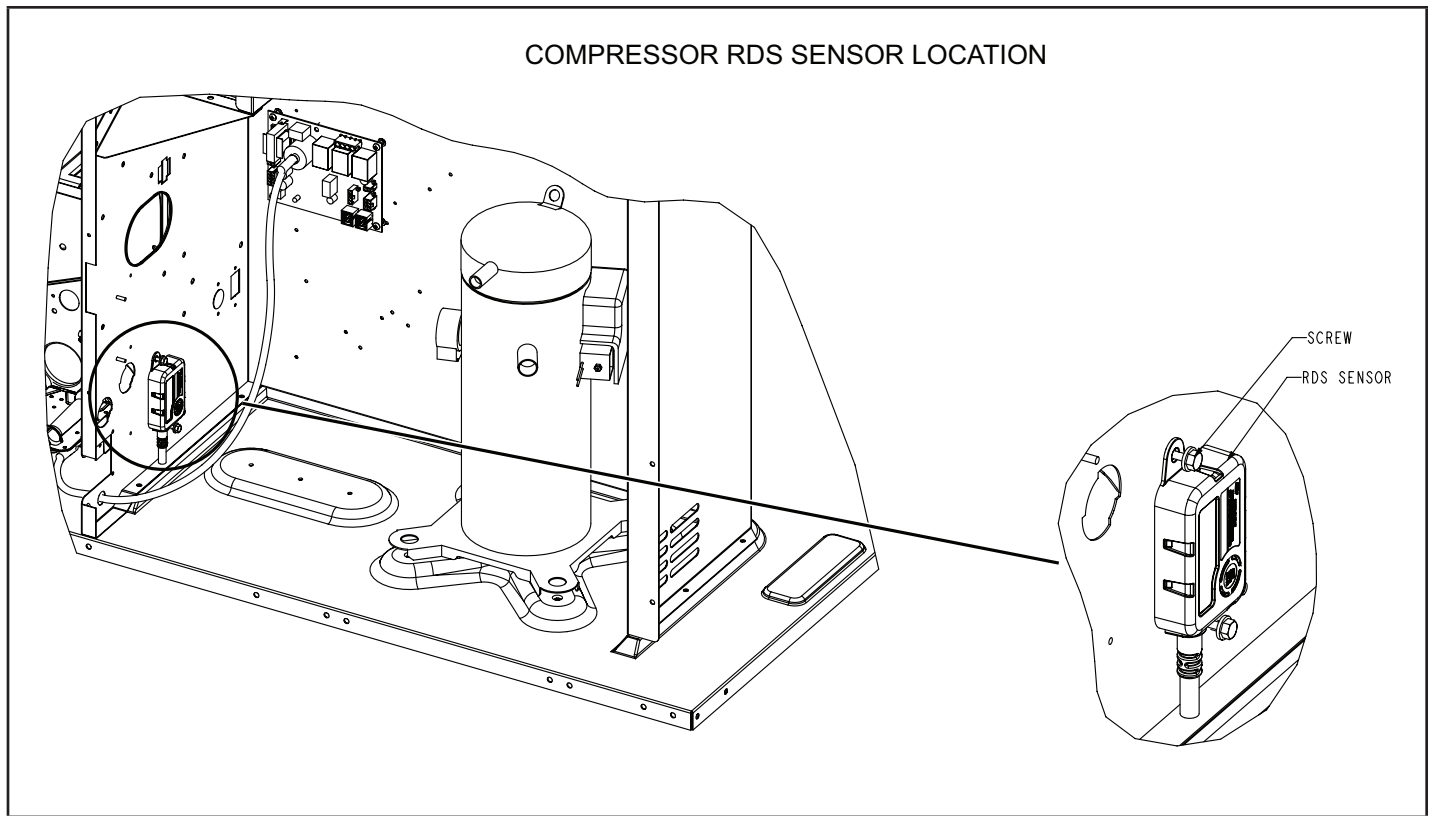

FIGURE 29

Cooling Operation

A-Two-Stage Thermostat

1 - Economizer With Outdoor Air Suitable

Y1 Demand -

Compressor Off
Blower Low
Dampers Modulate

Y2 Demand -

Compressor Low
Blower High
Dampers Full Open

NOTE - Compressor is energized after damper has been at full open for three minutes.

2 - No Economizer or Outdoor Air Not Suitable

Y1 Demand -

Compressor Low
Blower Low
Dampers Minimum Position

Y2 Demand -

Compressor High
Blower High
Dampers Minimum Position

B-Three-Stage Thermostat OR Room Sensor

1 - Economizer With Outdoor Air Suitable

Y1 Demand -

Compressors Off
Blower Low
Dampers Modulate

Y2 Demand -

Compressor Low
Blower High
Dampers Full Open

NOTE - Compressor is energized after damper has been at full open for three minutes.

Y3 Demand -

Compressor High
Blower High
Dampers Full Open

2 - No Economizer or Outdoor Air Not Suitable

Y1 Demand -

Compressor Low
Blower Low
Dampers Minimum Position

Y2 Demand -

Compressor High
Blower High
Dampers Minimum Position

Y3 Demand -

Compressor High
Blower High
Dampers Minimum Position

High speed compressor cooling operation:

**RTU MENU > COMPONENT TEST > COOLING >
COOLING STAGE 2**

Low speed compressor cooling operation:

**RTU MENU > COMPONENT TEST > COOLING >
COOLING STAGE 1**

Heating Operation

A-Heat Pump Operation

W1 Demand -

Compressor High
Blower Heating Speed
Reversing Valve De-Energized

W2 Demand (Optional Electric Heat) -

Compressor High Speed
Blower Heating Speed
Reversing Valve De-Energized
Optional Electric Heat Energized

NOTE - Electric heat is also energized during the defrost cycle.

B-Gas Heat Operation

1 - Outdoor Temperature ABOVE Balance Point Setpoint

W1 Demand -

Compressor High
Blower Heating Speed
Reversing Valve De-Energized

W2 Demand -

Compressor Off
Blower Heating Speed
Low Gas Heat Energized

NOTE - Gas heat is also energized during the defrost cycle.

2 - Outdoor Temperature BELOW Balance Point Setpoint

W1 Demand -

Compressor Off
Blower Heating Speed
Low Gas Heat Energized

W2 Demand -

Compressor Off
Blower Heating Speed
High Gas Heat Energized

NOTE - Gas heat is also energized during the defrost cycle.

High speed compressor heating operation:

RTU MENU > COMPONENT TEST > HEATING

Defrost Operation Test:

RTU MENU > COMPONENT TEST > DEFROST

Gas Heat Start-Up (LDT Units)

FOR YOUR SAFETY READ BEFORE LIGHTING

⚠ WARNING



Electric shock hazard. Can cause injury or death. Do not use this unit if any part has been under water. Immediately call a qualified service technician to inspect the unit and to replace any part of the control system and any gas control which has been under water.

⚠ WARNING



Danger of explosion. Can cause injury or product or property damage. If over heating occurs or if gas supply fails to shut off, shut off the manual gas valve to the appliance before shutting off electrical supply.

⚠ WARNING



Electric shock hazard. Can cause injury or death. Before attempting to perform any service or maintenance, turn the electrical power to unit OFF at disconnect switch(es). Unit may have multiple power supplies.

⚠ WARNING

SMOKE POTENTIAL

The heat exchanger in this unit could be a source of smoke on initial firing. Take precautions with respect to building occupants and property. Vent initial supply air outside when possible.

BEFORE LIGHTING smell all around the appliance area for gas. Be sure to smell next to the floor because some gas is heavier than air and will settle on the floor.

The gas valve may be equipped with either a gas control lever or gas control knob. Use only your hand to push the lever or turn the gas control knob. Never use tools. If the lever will not move or the knob will not push in or turn by hand, do not try to repair it. Call a qualified service technician. Force or attempted repair may result in a fire or explosion.

⚠ WARNING



Danger of explosion. Can cause injury or death. Do not attempt to light manually. Unit has a direct spark ignition system.

This unit is equipped with an automatic spark ignition system. There is no pilot. In case of a safety shutdown, move thermostat switch to OFF and return the thermostat switch to HEAT to reset ignition control.

A-Placing Unit In Operation

⚠ WARNING



Danger of explosion and fire. Can cause injury or product or property damage. You must follow these instructions exactly.

Gas Valve Operation (FIGURE 30)

- 1 - Set thermostat to lowest setting.
- 2 - Turn off all electrical power to appliance.
- 3 - This appliance is equipped with an ignition device which automatically lights the burner. Do not try to light the burner by hand.
- 4 - Open or remove the control access panel.

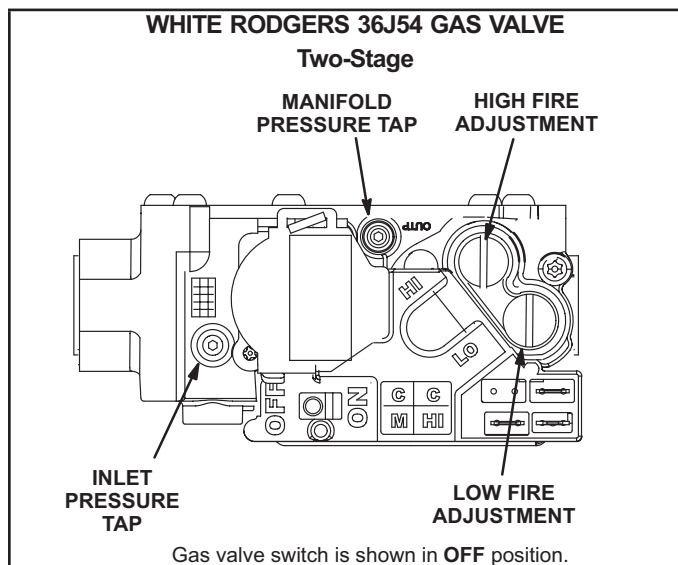

FIGURE 30

- 5 - Move gas valve switch to **OFF**. See FIGURE 30.
 - 6 - Wait five (5) minutes to clear out any gas. If you then smell gas, **STOP!** Immediately call your gas supplier from a neighbor's phone. Follow the gas supplier's instructions. If you do not smell gas, go to the next step.
 - 7 - Move gas valve switch to **ON**. See FIGURE 30.
 - 8 - Close or replace the control access panel.
 - 9 - Turn on all electrical power to appliance.
 - 10 - 1Set thermostat to desired setting.
- NOTE** - When unit is initially started, steps 1 through 9 may need to be repeated to purge air from gas line.
- 11 - The ignition sequence will start.

- 12 -If the furnace does not light the first time (gas line not fully purged), it will attempt up to two more ignitions before locking out.
- 13 -If lockout occurs, repeat steps 1 through 10.
- 14 -If the appliance will not operate, follow the instructions "Turning Off Gas to Appliance" and call your service technician or gas supplier.

Turning Off Gas to Unit

- 1 - If using an electromechanical thermostat, set to the lowest setting.
- 2 - Before performing any service, turn off all electrical power to the appliance.
- 3 - Open or remove the control access panel.
- 4 - Move gas valve switch to **OFF**.
- 5 - Close or replace the control access panel.

WARNING

Danger of explosion and fire. Can cause injury or product or property damage. You must follow these instructions exactly.

Heating Operation and Adjustments

(Gas Units)

A-Heating Sequence of Operation

Two-Stage

- 1 - On a heating demand the combustion air inducer starts immediately.
- 2 - Combustion air pressure switch proves inducer operation. After a 30-second pre-purge, power is allowed to ignition control. Switch is factory set and requires no adjustment.
- 3 - Spark ignitor energizes and gas valve solenoid opens.
- 4 - Spark ignites gas, ignition sensor proves the flame and combustion continues.
- 5 - If flame is not detected after 8 seconds, the ignition control will repeat steps 3 and 4 two more times. The ignition control will wait 5 minutes before the ignition attempt recycles.

B-Ignition Control Diagnostic LEDs

TABLE 13

IGNITION CONTROL HEARTBEAT LED STATUS

LED Flashes	Indicates
Steady OFF	No power or control hardware fault.
Steady ON	Power applied. Control OK.
3 Flashes	Ignition lockout from too many trials.
4 Flashes	Ignition lockout from too many flame losses within single call for heat.
5 Flashes	Control hardware fault detected.

C-Limit Controls

Limit controls are factory-set and are not adjustable. The primary limit is located to the right of the combustion air inducer. See FIGURE 35.

D-Heating Adjustment

Main burners are factory-set and do not require adjustment. The following manifold pressures are listed on the gas valve.

- Natural Gas Units - Low Fire - 2.0" w.c.
- Natural Gas Units - High Fire - 3.5" w.c.
- LP Gas Units - Low Fire - 5.9" w.c.
- LP Gas Units - High Fire - 10.5" w.c.

Electric Heat Start-Up (LHT Units)

Optional electric heat will stage on and cycle with thermostat demand. See electric heat wiring diagram on unit for sequence of operation.

SCR Electric Heat Controller (LHT Units)

Optional factory-installed SCR (A38) will provide small amounts of power to the electric heat elements to efficiently maintain warm duct air temperatures when there is no heating demand. The SCR maintains duct air temperature based on input from a field-provided and installed thermostat (A104) and duct sensor (RT20). SCR is located in the compressor section on the left wall. Use only with a thermostat or specified DDC control system.

Use the instructions provided with the thermostat to set DIP switches as follows: S1 On, S2 Off, S3 Off. Use the instructions provided with the duct sensor to install sensor away from electric element radiant heat and in a location where discharge air is a mixed average temperature.

Once power is supplied to unit, zero SCR as follows:

- 1 - Adjust thermostat (A104) to minimum position.
- 2 - Use a small screwdriver to slowly turn the ZERO potentiometer on the SCR until the LED turns solid red.
- 3 - Very slowly adjust the potentiometer the opposite direction until the LED turns off.

Preventative Maintenance / Repair

IMPORTANT MAINTENANCE / REPAIR SAFETY INSTRUCTIONS

Prior to beginning work on systems containing FLAMMABLE REFRIGERANTS, safety checks are necessary to ensure that the risk of ignition is minimized.

Work shall be undertaken under a controlled procedure to minimize the risk of a flammable gas or vapor being present while the work is being performed.

All maintenance staff and others working in the local area shall be instructed on the nature of work being carried out. Work in confined spaces shall be avoided.

The area shall be checked with an appropriate refrigerant detector prior to and during work, to ensure the technician is aware of potentially toxic or flammable atmospheres. Ensure that the leak detection equipment being used is suitable for use with all applicable refrigerants, i.e. non-sparking, adequately sealed or intrinsically safe.

If any hot work is to be conducted on the refrigerating equipment or any associated parts, appropriate fire extinguishing equipment shall be available to hand. Have a dry powder or CO2 fire extinguisher adjacent to the charging area.

No person carrying out work in relation to a REFRIGERATING SYSTEM which involves exposing any pipe work shall use any sources of ignition in such a manner that it may lead to the risk of fire or explosion. All possible ignition sources, including cigarette smoking, should be kept sufficiently far away from the site of installation, repairing, removing and disposal, during which refrigerant can possibly be released to the surrounding space. Prior to work taking place, the area around the equipment is to be surveyed to make sure that there are no flammable hazards or ignition risks. "No Smoking" signs shall be displayed.

Where electrical components are being changed, they shall be fit for the purpose and to the correct specification. At all times, the manufacturer's maintenance and service guidelines shall be followed. If in doubt, consult the manufacturer's technical department for assistance.

Repair and maintenance to electrical components shall include initial safety checks and component inspection procedures. If a fault exists that could compromise safety, then no electrical supply shall be connected to the circuit until it is satisfactorily dealt with. If the fault cannot be corrected immediately but it is necessary to continue operation, an adequate temporary solution shall be used. This shall be reported to the owner of the equipment so all parties are advised.

Initial safety checks shall include:

- that capacitors are discharged: this shall be done in a safe manner to avoid possibility of sparking
- that no live electrical components and wiring are exposed while charging, recovering or purging the system

- that there is continuity of earth bonding

The following checks shall be applied to installations using FLAMMABLE REFRIGERANTS:

- the actual REFRIGERANT CHARGE is in accordance with the room size within which the refrigerant containing parts are installed;
- the ventilation machinery and outlets are operating adequately and are not obstructed;
- if an indirect refrigerating circuit is being used, the secondary circuit shall be checked for the presence of refrigerant;
- marking to the equipment continues to be visible and legible. Markings and signs that are illegible shall be corrected;
- refrigerating pipe or components are installed in a position where they are unlikely to be exposed to any substance which may corrode refrigerant containing components, unless the components are constructed of materials which are inherently resistant to being corroded or are suitably protected against being so corroded.

During repairs to sealed electrical components, the components shall be replaced. Replacement parts shall be in accordance with the manufacturer's specifications.

During repairs to intrinsically safe components, the components must be replaced. Replace components only with parts specified by the manufacturer. Other parts may result in the ignition of refrigerant in the atmosphere from a leak.

The unit should be inspected once a year by a qualified service technician.

WARNING



Electric shock hazard. Can cause injury or death. Before attempting to perform any service or maintenance, turn the electrical power to unit OFF at disconnect switch(es). Unit may have multiple power supplies.

CAUTION

Label all wires prior to disconnection when servicing controls. Wiring errors can cause improper and dangerous operation. Verify proper operation after servicing.

A-Filters

Units are equipped with temporary filters which must be replaced prior to building occupation. Use four 20 X 20 X 2" (508 X 508 X 51mm) filters. Refer to local codes or appropriate jurisdiction for approved filters.

⚠ WARNING

Units are shipped from the factory with temporary filters. Replace filters before building is occupied. Damage to unit could result if filters are not replaced with approved filters. Refer to appropriate codes.

Approved filters should be checked monthly and replaced when necessary. Take note of air flow direction marking on filter frame when reinstalling filters. See FIGURE 31.

NOTE - Filters must be U.L.C. certified or equivalent for use in Canada.

B-Lubrication

All motors are lubricated at the factory. No further lubrication is required.

C-Burners (LDT Only)

Periodically examine burner flames for proper appearance during the heating season. Before each heating season examine the burners for any deposits or blockage which may have occurred.

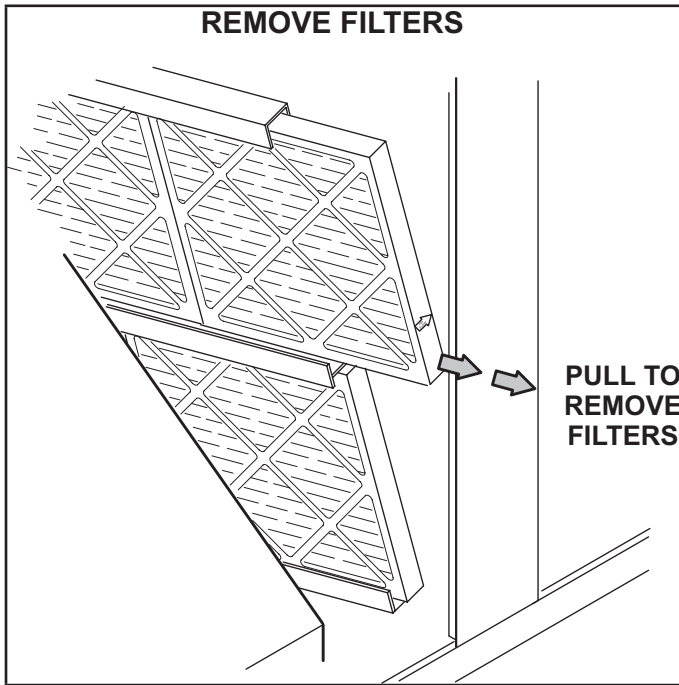

FIGURE 31

Clean burners as follows:

- 1 - Turn off both electrical power and gas supply to unit.
- 2 - Remove blower access panel.
- 3 - Remove top burner box panel.
- 4 - Remove screws securing burners to burner support and lift the individual burners or the entire burner assembly from the orifices. See FIGURE 32. Clean as necessary.
- 5 - Locate the ignitor under the right burner. Check ignitor spark gap with appropriately sized twist drills or feeler gauges. See FIGURE 33.
- 6 - Replace burners and screws securing burner. See FIGURE 32.

⚠ WARNING



Danger of explosion. Can cause injury or death. Do not overtighten main burner mounting screws. Snug tighten only.

- 7 - Replace access panel.
- 8 - Restore electrical power and gas supply. Follow lighting instructions attached to unit and use inspection port in access panel to check flame.

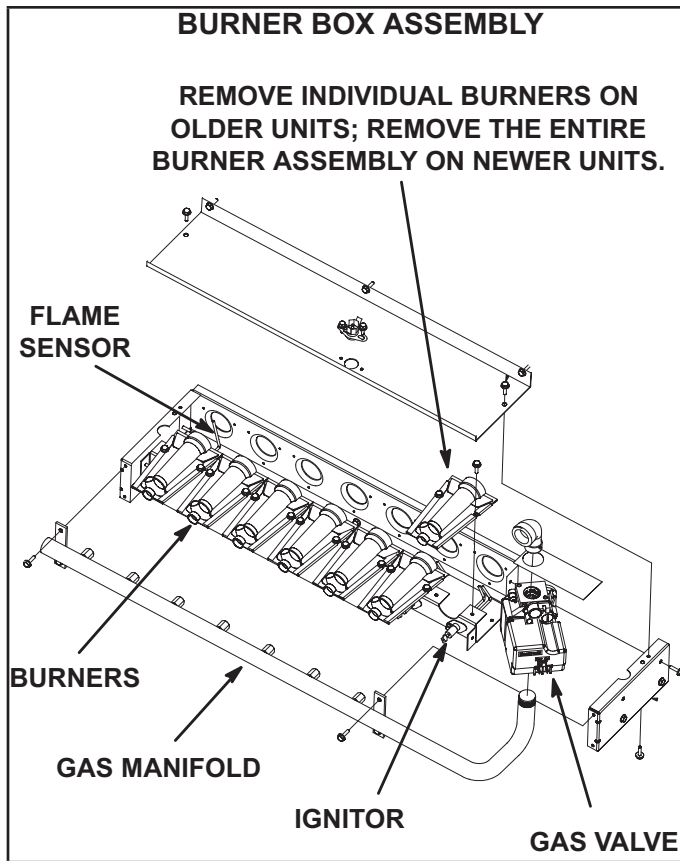

FIGURE 32

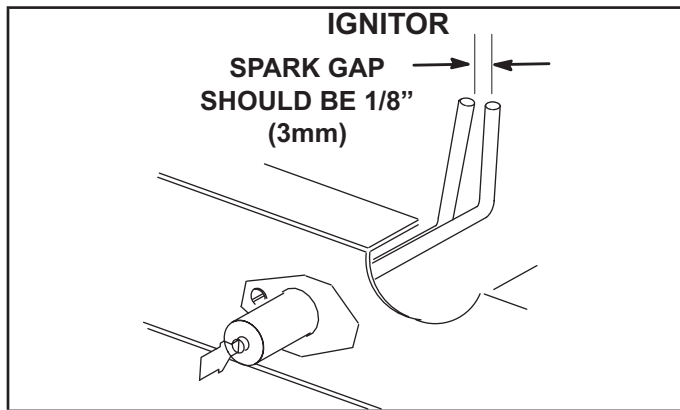

FIGURE 33

D-Combustion Air Inducer (LDT Only)

A combustion air proving switch checks combustion air inducer operation before allowing power to the gas controller. Gas controller will not operate if inducer is obstructed.

Under normal operating conditions, the combustion air inducer wheel should be checked and cleaned prior to the heating season. However, it should be examined periodically during the heating season to establish an ideal cleaning schedule.

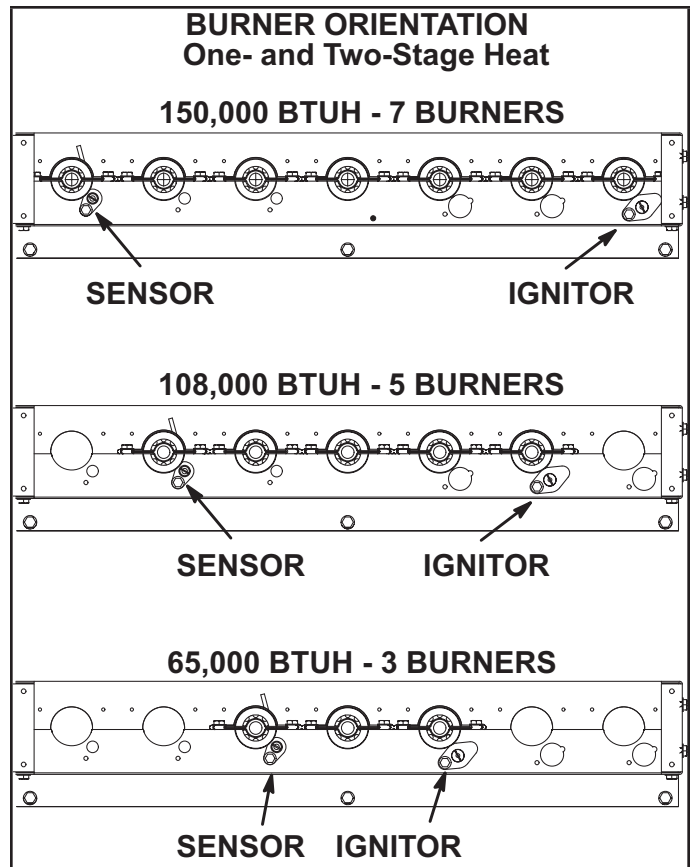

FIGURE 34

Clean combustion air inducer as follows:

- 1 - Shut off power supply and gas to unit.
- 2 - Remove the mullion on the right side of the heat section.
- 3 - Disconnect pressure switch air tubing from combustion air inducer port.
- 4 - Remove and retain screws securing combustion air inducer to flue box. Remove vent connector. See FIGURE 35.
- 5 - Clean inducer wheel blades with a small brush and wipe off any dust from housing. Take care not to damage exposed fan blades. Clean accumulated dust from front of flue box cover.
- 6 - Return combustion air inducer motor and vent connector to original location and secure with retained screws. It is recommended that gaskets be replaced during reassembly.
- 7 - Replace mullion.
- 8 - Clean combustion air inlet louvers on blower access panel using a small brush.

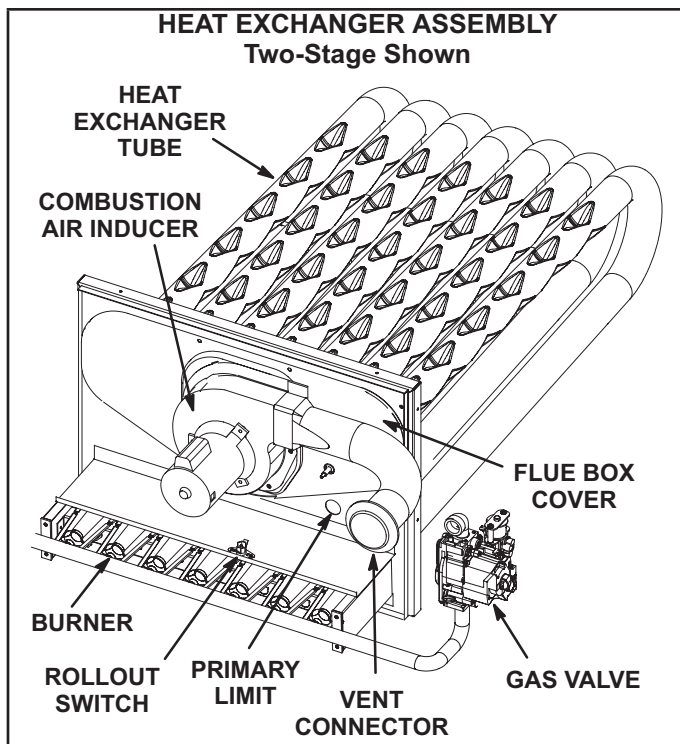

FIGURE 35

E-Flue Box (LDT Units)

Remove flue box cover only when necessary for equipment repair. Clean inside of flue box cover and heat exchanger tubes with a wire brush when flue box cover has to be removed. Install a new flue box cover gasket and replace cover. Make sure edges around flue box cover are tightly sealed.

F-Evaporator Coil

Inspect and clean coil at beginning of each cooling season. Clean using mild detergent or commercial coil cleaner. Flush coil and condensate drain with water taking care not to get insulation, filters and return air ducts wet.

G-Condenser Coil

Clean condenser coil annually with detergent or commercial coil cleaner and inspect monthly during the cooling season.

Condenser coils are made of single and two formed slabs. On units with two slabs, dirt and debris may become trapped between the slabs. To clean between slabs, carefully separate coil slabs and wash them thoroughly. See FIGURE 36. Flush coils with water following cleaning.

NOTE - Remove all screws and gaskets prior to cleaning procedure and replace upon completion.

H-Supply Air Blower Wheel

Annually inspect supply air blower wheel for accumulated dirt or dust. Turn off power before attempting to remove access panel or to clean blower wheel.

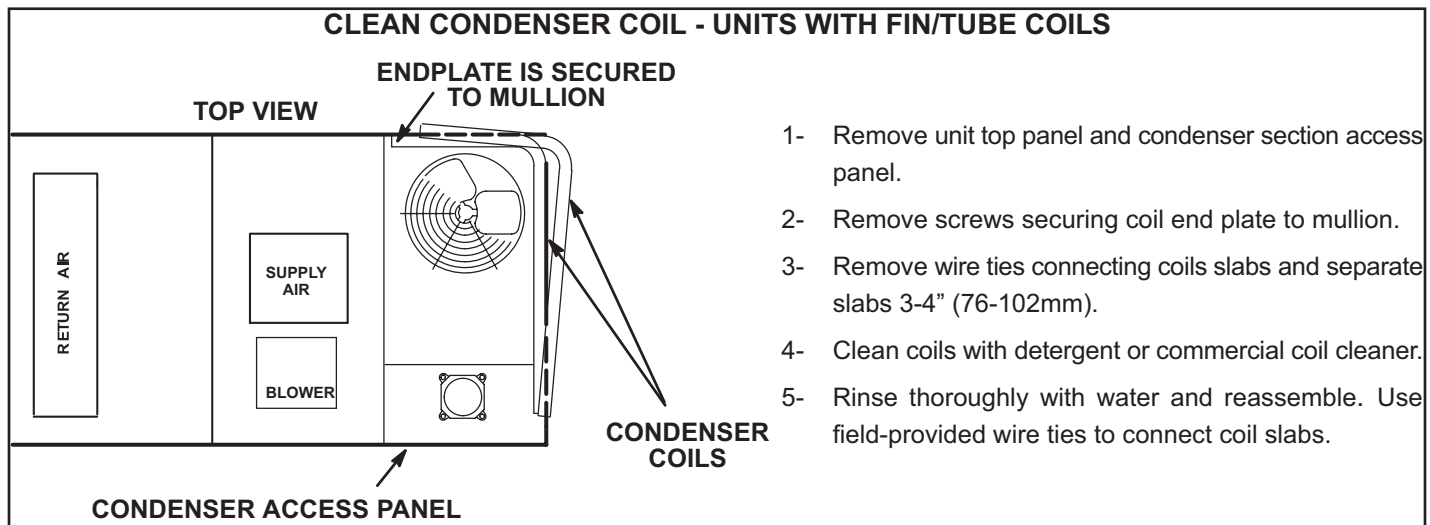

FIGURE 36

J-Needlepoint Bipolar Ionizer (Optional)

The optional, brush-type ionizer produces positive and negative ions to clean air and reduce airborne contaminants. The ionizer was designed to be low maintenance. The device should be checked semi-annually to confirm the brushes are clean for maximum output. The ionizer is located behind on the blower deck to the left of the blower. See FIGURE 38.

- 1 - On the back side of the unit, remove the screw securing the back of the ionizer bracket. See FIGURE 37. Retain the screw to secure the back side of the ionizer bracket.
- 2 - Remove two screws securing the front side of the ionizer bracket and pull out of unit and clean brushes.
- 3 - Replace ionizer in the reverse order it was removed.

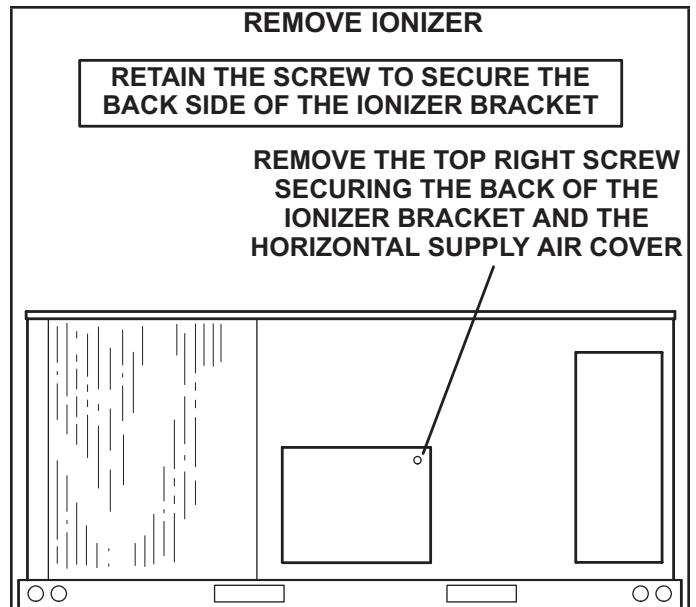

FIGURE 37

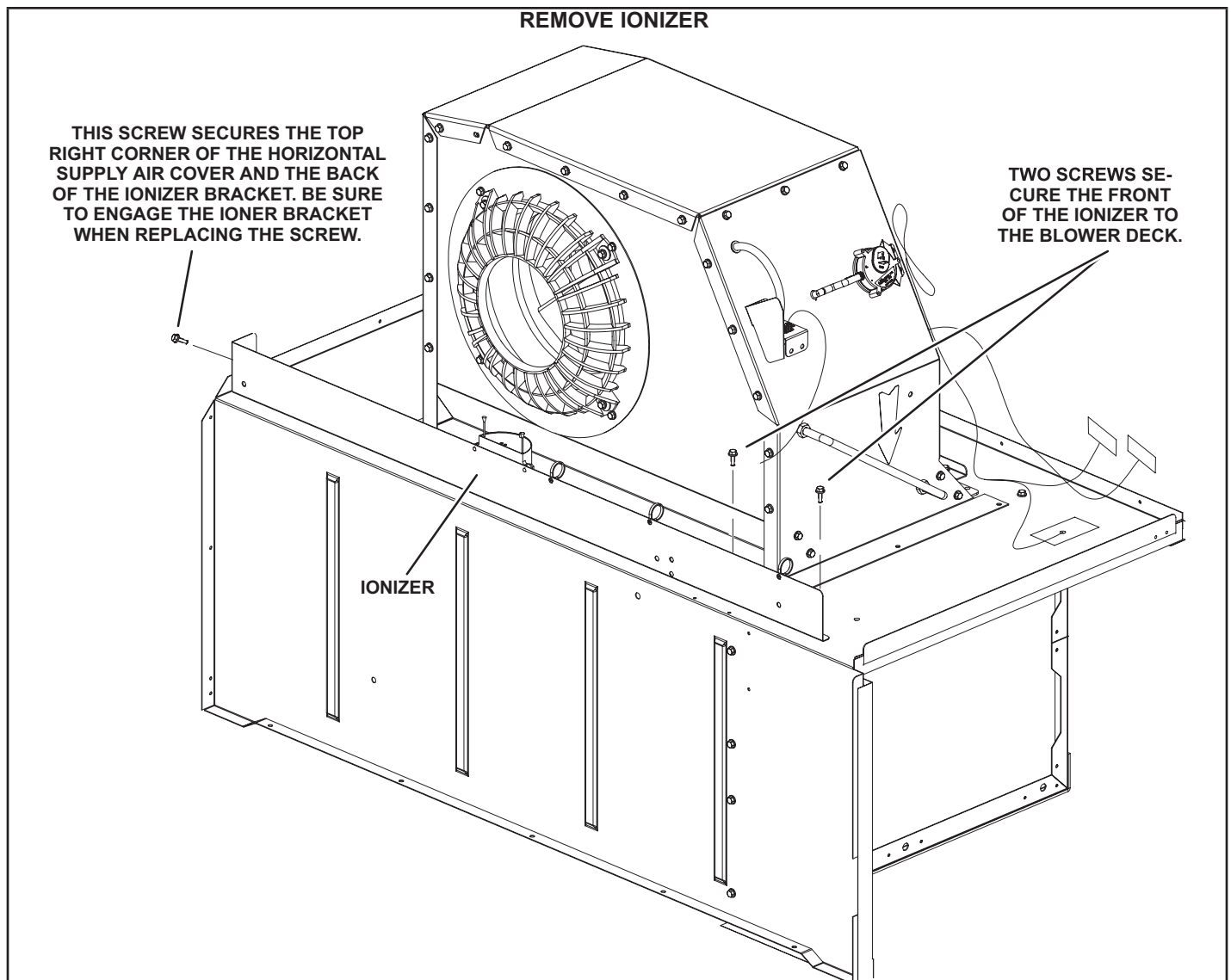

FIGURE 38

K-UVC Light (Optional)

When field-installed, use only UVC Light Kit assembly 106881-01 (21A92) with this appliance.

Factory-Installed UVC Light

When the UVC light is factory installed, the lamp is shipped attached to the filter rack. Remove the lamp and install into the UVC light assembly as shown in steps 2 through 11.

- 1 - Cut wire ties and remove the UVC lamp attached to the filter rack. See FIGURE 39.

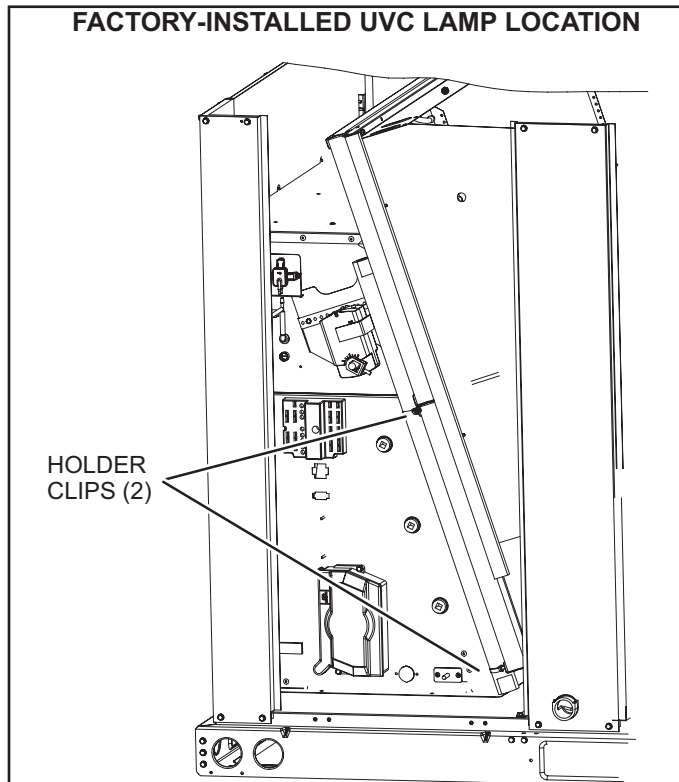

FIGURE 39

Annual Lamp Replacement

⚠ WARNING

Personal Burn Hazard.

Personal injury may result from hot lamps. During replacement, allow lamp to cool for 10 minutes before removing lamp from fixture.

The lamp should be replaced every 12 months, as UVC energy production diminishes over time.

- 1 - Obtain replacement lamp 102337-01 for your germicidal light model.
- 2 - Disconnect power to the rooftop unit before servicing the UVC kit.
- 3 - Open the blower access door.
- 4 - Remove the screw in wire tie from the UVC assembly and disconnect the 4-pin connector from the lamp end.

- 5 - Remove the (2) mounting screws of the UVC assembly. Carefully slide the complete UVC assembly out through the blower access door.
- 6 - Allow 10 minutes before touching the lamps. Then, carefully remove the old lamp from the lamp holder clips.
- 7 - Wear cotton gloves or use a cotton cloth when handling the new lamp. Place the new lamp in the holder clips of the UVC assembly. Verify that the lamp flange at the connector end is sandwiched between the lamp holder clip and the sheet-metal end stop (see FIGURE 40).
- 8 - Carefully place the UVC assembly on the blower deck. Line up the mounting holes on the UVC assembly with the mounting holes on the blower deck. See FIGURE 41. Use the #10 screws provided to attach the UVC assembly in place.
- 9 - Make sure to reapply the black convoluted tubing used to shield electrical wiring in the rooftop unit. Convoluted tubing is provided when the ionizer is factory- or field-installed. However, if there is any concern, aluminum foil tape (not provided) can also be used to cover any exposed component.
- 10 - Close the blower access door.
- 11 - Reconnect power to the rooftop unit.
- 12 - Open the filter access door and look through the view port in the triangular sheet-metal panel to verify that the UVC light is on.

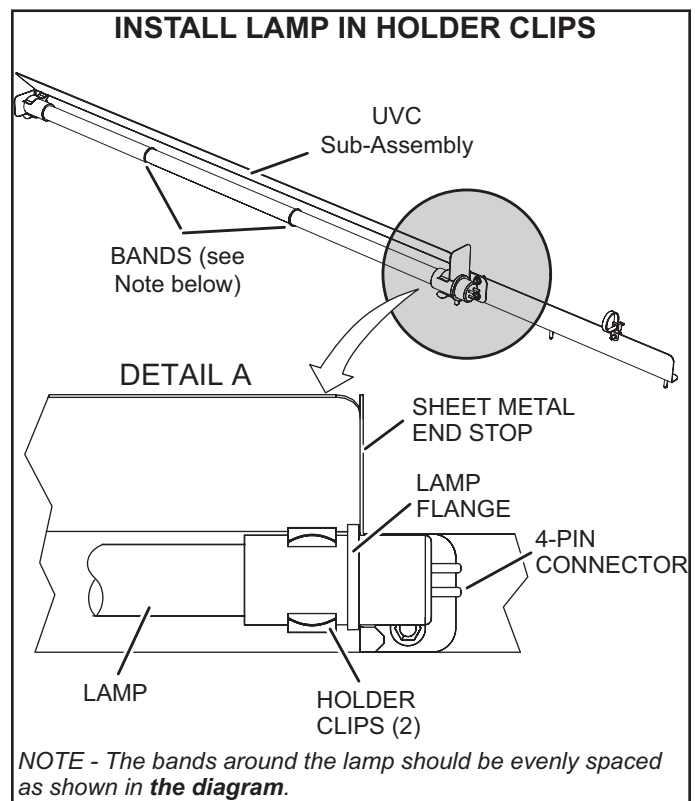

FIGURE 40

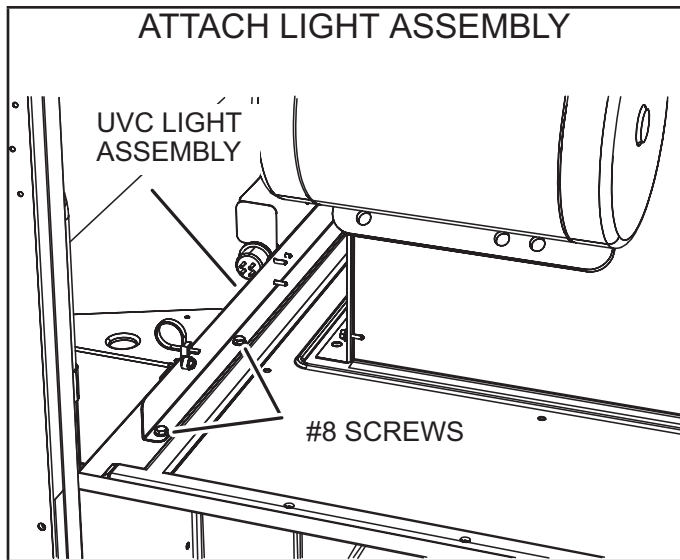

FIGURE 41

Lamp Disposal

NOTE - UV Lamp Contains Mercury. Dispose According to Local, State, or Federal Laws.

Proper Clean-up Technique in Case of Lamp Breakage

Wear protective gloves, eye wear and mask.

Sweep the broken glass and debris into a plastic bag, seal the bag, and dispose of properly. Contact your local waste management office for proper disposal.

Do not use a vacuum cleaner. Do not incinerate.

Maintenance

- For all maintenance, contact a qualified HVAC technician.
- Read the maintenance instructions before opening unit panels.
- Unintended use of the unit or damage to the unit housing may result in the escape of dangerous UVC radiation. UVC radiation may, even in small doses, cause harm to the eyes and skin.
- Do not operate units that are obviously damaged.
- Do not discard the triangular UVC light shield or any barriers with an ultraviolet radiation symbol.
- Do not override the door interlock switch that interrupts power to the UVC light.
- Do not operate the UVC light outside of the unit.

L-Replacement Fuses

See the following tables for the proper replacement fuse sizes.

ELECTRIC HEAT REPLACEMENT FUSES				
	Electric Heat	Qty.	Rating	
			Amp	Volt
1	E1EH0050N-1P	2	30	250
2	T1/E1EH0075AN1Y	3	25	250
3	E1EH0100N-1P	4	30	250
4	T1/E1EH0150AN1Y	3	50	250
5	T1/E1EH0225AN1Y	6	45	250
6	T1/E1EH0300N-1Y	6	60	250
7	E2EH0300N-1Y	6	60	250
8	K1EH0050A-1P	2	30	250
9	T1/E1EH0075AN1P	2	40	250
10	T1EH0100A-1P	4	30	250
11	T1/E1EH0150AN1P	4	40	250
12	T1/E1EH0225AN1P	6	40	250
13	T1/E1EH0075AN1J	3	15	600
14	T1/E1EH0150AN1J	3	20	600
15	T1/E1EH0225AN1J	3	30	600
16	T1/E1EH0300N-1J	3	40	600
17	T1/E1EH0075AN1G	3	15	600
18	T1/E1EH0150AN1G	3	25	600
19	T1/E1EH0225AN1G	3	35	600
20	T1/E1EH0300N-1G	3	50	600
21	K1/E1EH0057AN1M	3	15	600
22	K1/E1EH0115AN1M	3	20	600
23	K1EH0172AN1M	3	30	600
24	E1EH0172N-1M	3	30	600
25	K1/E1EH0230N-1M	3	40	600

TABLE 14

LHT036H5E																		
Electric Heat Size			7.5 KW								15 KW							
Unit Voltage			208/230V - 1 Ph		208/230V - 3 Ph		460V - 3 Ph		575V - 3 Ph		208/230V - 1 Ph		208/230V - 3 Ph		460V - 3 Ph		575V - 3 Ph	
Power Exhaust Option			W/ P.E.	W/O P.E.	W/ P.E.	W/O P.E.	W/ P.E.	W/O P.E.	W/ P.E.	W/O P.E.	W/ P.E.	W/O P.E.	W/ P.E.	W/O P.E.	W/ P.E.	W/O P.E.	W/ P.E.	W/O P.E.
Diagram Key	Class	Blower HP	Amps								Amps							
F4	RK or K1	0.5	40	35	30	25	15	15	15	15	40	35	30	25	15	15	15	15
F4	RK or K1	1.5	-	-	30	25	15	15	15	15	-	-	30	25	15	15	15	15
F10 ²	CC	All	8	8	8	8	8	8	8	8	8	8	8	8	8	8	8	8
F27	CC	1.5	-	-	-	-	-	-	7.5	7.5	-	-	-	-	-	-	7.5	7.5
F30	CC	All	10	10	10	10	5	5	-	-	10	10	10	10	5	5	-	-
F31	CC	All	-	15	-	15	-	15	-	-	-	15	-	15	-	15	-	-
F57	CC	0.5	-	-	-	-	3.5	3.5	5	5	-	-	-	-	3.5	3.5	5	5
F57	CC	1.5	-	-	-	-	10	10	7.5	7.5	-	-	-	-	10	10	7.5	7.5
F61 ²	J	0.5	70	70	45	45	25	25	20	20	110	110	70	70	35	35	30	30
F61 ²	J	1.5	-	-	45	45	25	25	20	20	-	-	70	70	35	35	30	30
CB10 ³	-	0.5	70	70	45	45	25	25	20	20	110	110	70	70	35	35	30	30
CB10 ³	-	1.5	-	-	45	45	25	25	20	20	-	-	70	70	35	35	30	30

¹ When SCCR is installed, F4 fuse is Class J.

² Fuses F10 and F61 are only used on units with SCCR installed.

³ Units using Circuit Breakers will use CB10 option.

LHT048H5E																		
Electric Heat Size			7.5 KW								15 KW							
Unit Voltage			208/230V - 1 Ph		208/230V - 3 Ph		460V - 3 Ph		575V - 3 Ph		208/230V - 1 Ph		208/230V - 3 Ph		460V - 3 Ph		575V - 3 Ph	
Power Exhaust Option			W/ P.E.	W/O P.E.	W/ P.E.	W/O P.E.	W/ P.E.	W/O P.E.	W/ P.E.	W/O P.E.	W/ P.E.	W/O P.E.	W/ P.E.	W/O P.E.	W/ P.E.	W/O P.E.	W/ P.E.	W/O P.E.
Diagram Key	Class	Blower HP	Amps								Amps							
F4	RK or K1	1.0	50	50	35	35	20	20	15	15	50	50	35	35	20	20	15	15
F4	RK or K1	1.5	-	-	35	30	20	15	15	15	-	-	35	30	20	15	15	15
F10 ²	CC	All	8	8	8	8	8	8	8	8	8	8	8	8	8	8	8	8
F27	CC	1.5	-	-	-	-	-	-	7.5	7.5	-	-	-	-	-	-	7.5	7.5
F30	CC	All	10	10	10	10	5	5	-	-	10	10	10	10	5	5	-	-
F31	CC	All	-	15	-	15	-	15	-	-	-	15	-	15	-	15	-	-
F57	CC	1.0	-	-	-	-	3.5	3.5	5	5	-	-	-	-	3.5	3.5	5	5
F57	CC	1.5	-	-	-	-	10	10	7.5	7.5	-	-	-	-	10	10	7.5	7.5
F61 ²	J	1.0	80	80	60	50	30	25	25	20	125	125	80	80	40	40	30	30
F61 ²	J	1.5	-	-	50	50	25	25	20	20	-	-	70	70	40	35	30	30
CB10 ³	-	1.0	80	80	60	50	30	25	25	20	125	125	80	80	40	40	30	30
CB10 ³	-	1.5	-	-	50	50	25	25	20	20	-	-	70	70	40	35	30	30

When SCCR is installed, F4 fuse is Class J.

² Fuses F10 and F61 are only used on units with SCCR installed.

³ Units using Circuit Breakers will use CB10 option.

LHT060H5E																		
Electric Heat Size			7.5 KW								15 KW							
Unit Voltage			208/230V - 1 Ph		208/230V - 3 Ph		460V - 3 Ph		575V - 3 Ph		208/230V - 1 Ph		208/230V - 3 Ph		460V - 3 Ph		575V - 3 Ph	
Power Exhaust Option			W / P.E.	W / O P.E.	W / P.E.	W / O P.E.	W / P.E.	W / O P.E.	W / P.E.	W / O P.E.	W / P.E.	W / O P.E.	W / P.E.	W / O P.E.	W / P.E.	W / O P.E.	W / P.E.	W / O P.E.
Diagram Key	Class	Blower HP	Amps								Amps							
F4	RK or K1	1.0	60	60	40	35	20	15	15	15	60	60	40	35	20	15	15	15
F4	RK or K1	1.5	-	-	40	35	20	15	15	15	-	-	40	35	20	15	15	15
F10 ²	CC	All	8	8	8	8	8	8	8	8	8	8	8	8	8	8	8	8
F27	CC	1.5	-	-	-	-	-	-	7.5	7.5	-	-	-	-	-	-	7.5	7.5
F30	CC	All	10	10	10	10	5	5	-	-	10	10	10	10	5	5	-	-
F31	CC	All	-	15	-	15	-	15	-	-	-	15	-	15	-	15	-	-
F57	CC	1.0	-	-	-	-	3.5	3.5	5	5	-	-	-	-	3.5	3.5	5	5
F57	CC	1.5	-	-	-	-	10	10	7.5	7.5	-	-	-	-	10	10	7.5	7.5
F61 ²	J	1.0	90	90	50	50	25	25	25	20	125	125	80	70	40	35	30	30
F61 ²	J	1.5	-	-	50	50	25	25	25	20	-	-	80	70	40	35	30	30
CB10 ³	-	1.0	90	90	50	50	25	25	25	20	125	125	80	70	40	35	30	30
CB10 ³	-	1.5	-	-	50	50	25	25	25	20	-	-	80	70	40	35	30	30

¹ When SCCR is installed, F4 fuse is Class J.

² Fuses F10 and F61 are only used on units with SCCR installed.

³ Units using Circuit Breakers will use CB10 option.

LHT060H5E continued																		
Electric Heat Size			22.5 KW															
Unit Voltage			208/230V - 1 Ph		208/230V - 3 Ph		460V - 3 Ph		575V - 3 Ph		208/230V - 1 Ph		208/230V - 3 Ph		460V - 3 Ph		575V - 3 Ph	
Power Exhaust Option			W / P.E.	W / O P.E.	W / P.E.	W / O P.E.	W / P.E.	W / O P.E.	W / P.E.	W / O P.E.	W / P.E.	W / O P.E.	W / P.E.	W / O P.E.	W / P.E.	W / O P.E.	W / P.E.	W / O P.E.
Diagram Key	Class	Blower HP	Amps								Amps							
F4	RK or K1	1.0	60	60	40	35	20	15	15	15	60	60	40	35	20	15	15	15
F4	RK or K1	1.5	-	-	40	35	20	15	15	15	-	-	40	35	20	15	15	15
F10 ²	CC	All	8	8	8	8	8	8	8	8	8	8	8	8	8	8	8	8
F27	CC	1.5	-	-	-	-	-	-	-	-	-	-	-	-	7.5	7.5	-	-
F30	CC	All	10	10	10	10	5	5	-	-	10	10	10	10	5	5	-	-
F31	CC	All	-	15	-	15	-	15	-	-	-	15	-	15	-	15	-	-
F57	CC	1.0	-	-	-	-	-	-	-	-	3.5	3.5	5	5	5	5	5	5
F57	CC	1.5	-	-	-	-	-	-	-	-	10	10	7.5	7.5	7.5	7.5	7.5	7.5
F61 ²	J	1.0	175	175	100	100	100	100	50	50	50	50	40	40	40	40	40	40
F61 ²	J	1.5	-	-	100	100	100	100	50	50	50	50	40	40	40	40	40	40
CB10 ³	-	1.0	175	175	110	110	110	110	50	50	50	50	40	40	40	40	40	40
CB10 ³	-	1.5	-	-	100	100	100	100	50	50	50	50	40	40	40	40	40	40

¹ When SCCR is installed, F4 fuse is Class J.

² Fuses F10 and F61 are only used on units with SCCR installed.

³ Units using Circuit Breakers will use CB10 option.

LHT072H5E														
Electric Heat Size			7.5 KW						15 KW					
Unit Voltage			208/230V - 3 Ph		460V - 3 Ph		575V - 3 Ph		208/230V - 3 Ph		460V - 3 Ph		575V - 3 Ph	
Power Exhaust Option			W / P.E.	W / O P.E.	W / P.E.	W / O P.E.	W / P.E.	W / O P.E.	W / P.E.	W / O P.E.	W / P.E.	W / O P.E.	W / P.E.	W / O P.E.
Diagram Key	Class	Blower HP	Amps						Amps					
F4	RK or K ¹	1.5	40	40	20	20	15	15	40	40	20	20	15	15
F10 ²	CC	All	8	8	8	8	8	8	8	8	8	8	8	8
F27	CC	1.5	-	-	-	-	7.5	7.5	-	-	-	-	7.5	7.5
F30	CC	All	10	10	5	5	-	-	10	10	5	5	-	-
F31	CC	All	-	15	-	15	-	-	-	15	-	15	-	-
F57	CC	1.5	-	-	10	10	7.5	7.5	-	-	10	10	7.5	7.5
F61 ²	J	1.5	50	50	25	25	25	20	80	70	40	35	30	30
CB10 ³	-	1.5	50	50	25	25	25	20	80	70	40	35	30	30

¹ When SCCR is installed, F4 fuse is Class J.

² Fuses F10 and F61 are only used on units with SCCR installed.

³ Units using Circuit Breakers will use CB10 option.

LHT072 continued									
Electric Heat Size			22.5 KW						
Unit Voltage			208/230V - 3 Ph		460V - 3Ph		575V - 3 Ph		
Power Exhaust Option			W / P.E.	W / O P.E.	W / P.E.	W / O P.E.	W / P.E.	W / O P.E.	W / O P.E.
Diagram Key	Class	Blower HP	Amps						
F4	RK or K ¹	1.5	40	40	20	20	15	15	
F10 ²	CC	All	8	8	8	8	8	8	
F27	CC	1.5	-	-	-	-	7.5	7.5	
F30	CC	All	10	10	5	5	-	-	
F31	CC	All	-	15	-	15	-	-	
F57	CC	1.5	-	-	10	10	7.5	7.5	
F61 ²	J	1.5	100	100	50	50	40	40	
CB10 ³	-	1.5	100	100	50	50	40	40	

¹ When SCCR is installed, F4 fuse is Class J.

² Fuses F10 and F61 are only used on units with SCCR installed.

³ Units using Circuit Breakers will use CB10 option.

UNIT REPLACEMENT FUSES										
LDT036H5E										
Unit Voltage			208/230V - 1 Ph		208/230V - 3 Ph		460V - 3Ph		575V - 3Ph	
Power Exhaust Option			W / P.E.	W / O P.E.	W / P.E.	W / O P.E.	W / P.E.	W / O P.E.	W / P.E.	W / O P.E.
Diagram Key	Class	Blower HP	Amps							
F10 ²	CC	All	8	8	8	8	8	8	8	8
F27	CC	1.5	-	-	-	-	-	-	7.5	7.5
F30	CC	All	10	10	10	10	5	5	-	-
F31	CC	All	-	15	-	15	-	15	-	-
F57	CC	0.5	-	-	-	-	3.5	3.5	5	5
F57	CC	1.5	-	-	-	-	10	10	7.5	7.5
F61 ²	J	0.5	40	35	30	25	15	15	15	15
F61 ²	J	1.5	-	-	30	25	15	15	15	15
CB10 ³	-	0.5	40	35	30	25	15	15	15	15
CB10 ³	-	1.5	-	-	30	25	15	15	15	15

² Fuses F10 and F61 are only used on units with SCCR installed.

³ Units using Circuit Breakers will use CB10 option.

UNIT REPLACEMENT FUSES										
LDT048H5E										
Unit Voltage			208/230V - 1 Ph		208/230V - 3 Ph		460V - 3Ph		575V - 3Ph	
Power Exhaust Option			W / P.E.	W / O P.E.	W / P.E.	W / O P.E.	W / P.E.	W / O P.E.	W / P.E.	W / O P.E.
Diagram Key	Class	Blower HP	Amps							
F10 ²	CC	All	8	8	8	8	8	8	8	8
F27	CC	1.5	-	-	-	-	-	-	7.5	7.5
F30	CC	All	10	10	10	10	5	5	-	-
F31	CC	All	-	15	-	15	-	15	-	-
F57	CC	1.0	-	-	-	-	3.5	3.5	5	5
F57	CC	1.5	-	-	-	-	10	10	7.5	7.5
F61 ²	J	1.0	50	50	35	35	20	20	15	15
F61 ²	J	1.5	-	-	35	30	20	15	15	15
CB10 ³	-	1.0	50	50	35	35	20	20	15	15
CB10 ³	-	1.5	-	-	35	30	20	15	15	15

² Fuses F10 and F61 are only used on units with SCCR installed.

³ Units using Circuit Breakers will use CB10 option.

UNIT REPLACEMENT FUSES										
LDT060H5E										
Unit Voltage			208/230V - 1 Ph		208/230V - 3 Ph		460V - 3Ph		575V - 3Ph	
Power Exhaust Option			W / P.E.	W / O P.E.	W / P.E.	W / O P.E.	W / P.E.	W / O P.E.	W / P.E.	W / O P.E.
Diagram Key	Class	Blower HP	Amps							
F10 ²	CC	All	8	8	8	8	8	8	8	8
F27	CC	1.5	-	-	-	-	-	-	7.5	7.5
F30	CC	All	10	10	10	10	5	5	-	-
F31	CC	All	-	15	-	15	-	15	-	-
F57	CC	1.0	-	-	-	-	3.5	3.5	5	5
F57	CC	1.5	-	-	-	-	10	10	7.5	7.5
F61 ²	J	1.0	60	60	40	40	20	20	15	15
F61 ²	J	1.5	-	-	40	35	20	15	15	15
CB10 ³	-	1.0	60	60	40	40	20	20	15	15
CB10 ³	-	1.5	-	-	40	35	20	15	15	15

² Fuses F10 and F61 are only used on units with SCCR installed.

³ Units using Circuit Breakers will use CB10 option.

UNIT REPLACEMENT FUSES										
LDT072H5E										
Unit Voltage			208/230V - 3 Ph		460V - 3Ph		575V - 3Ph			
Power Exhaust Option			W / P.E.	W / O P.E.	W / P.E.	W / O P.E.	W / P.E.	W / O P.E.		
Diagram Key	Class	Blower HP	Amps							
F10 ²	CC	All	8	8	8	8	8	8	8	
F27	CC	1.5	-	-	-	-	-	7.5	7.5	
F30	CC	All	10	10	5	5	-	-		
F31	CC	All	-	15	-	15	-	-		
F57	CC	1.5	-	-	10	10	7.5	7.5		
F61 ²	J	1.5	50	50	25	25	15	15		
CB10 ³	-	1.5	50	50	25	25	15	15		

² Fuses F10 and F61 are only used on units with SCCR installed.

³ Units using Circuit Breakers will use CB10 option.

Factory Unit Controller Settings

Use the mobile service app to adjust parameters; menu paths are shown in each table. Refer to the Unit Controller manual provided with each unit.

When field installing optional kits and accessories, the Unit Controller must be configured to identify the option before it will function. Refer to FIGURE 42 and FIGURE 43 to determine whether the Unit Controller configuration I.D. must change. To configure the option, use MAIN MENU > SETUP > INSTALL menu path. Press SAVE until CONFIGURATION ID 1 or 2 appears depending on the option installed. Change the appropriate character in the configuration I.D. For example, when an economizer is installed using a single enthalpy sensor, change configuration I.D. 1, the second character, to "S".

Decommissioning

Before carrying out this procedure, it is essential that the technician is completely familiar with the equipment and all its detail. It is recommended good practice that all refrigerants are recovered safely.

Prior to the task being carried out, an oil and refrigerant sample shall be taken in case analysis is required prior to re-use of recovered refrigerant. It is essential that electrical power is available before starting decommissioning.

- a) Become familiar with the equipment and its operation.
- b) Isolate system electrically.
- c) Before attempting the procedure, ensure that:
 - mechanical handling equipment is available, if required, for handling refrigerant cylinders;
 - all personal protective equipment is available and being used correctly;

- the recovery process is supervised at all times by a competent person;
- recovery equipment and cylinders conform to the appropriate standards.

- d) Pump down refrigerant system, if possible.
- e) If a vacuum is not possible, make a manifold so that refrigerant can be removed from various parts of the system.
- f) Make sure that cylinder is situated on the scales before recovery takes place.
- g) Start the recovery machine and operate in accordance with instructions.
- h) Do not overfill cylinders (no more than 80% volume liquid charge).
- i) Do not exceed the maximum working pressure of the cylinder, even temporarily.
- j) When the cylinders have been filled correctly and the process completed, make sure that the cylinders and the equipment are removed from site promptly and all isolation valves on the equipment are closed off.
- k) Recovered refrigerant shall not be charged into another REFRIGERATING SYSTEM unless it has been cleaned and checked.

IMPORTANT

Equipment shall be labelled stating that it has been decommissioned and emptied of refrigerant. The label shall be signed and dated. Ensure that there are labels on the equipment that state the flammability of the refrigerant used.

M4 Unit Controller Configuration ID 1

1 2 3 4 5 6 7 8

Humiditrol [1]

Not Installed = **N**
 Humiditrol Installed = **H**
 Unconfigured = **U**

Economizer [2]

Not Installed = **N**
 Motorized Outdoor Air Damper Only = **M**
 Economizer - Temperature = **T**
 Economizer Global = **G**
 Economizer - Single Enthalpy = **S**
 Economizer - Dual Enthalpy = **D**
 Unconfigured = **U**

Power Exhaust [3]

Not Installed = **N**
 Dual-Stage = **D**
 Single-Stage = **S**
 Unconfigured = **U**

Power Exhaust Control [4]

Not Installed = **N**
 Damper Position = **A**
 A34 Pressure Sensor = **C**

[8] Outdoor Air Control

N = No Outdoor Air CFM Control
L = Outdoor Air Control Installed with A24 Sensor set for low range.
M = Outdoor Air Control Installed with A24 Sensor set for medium range.
H = Outdoor Air Control Installed with A24 Sensor set for high range.

[7] System Blower Sub-type

N = Not Applicable
B = VFD Belt Drive Blower (MODBUS)
H = Direct-Plus® Blower (MODBUS)
L = ECM Direct-Drive Blower (PWM)
U = Unconfigured
D = Direct Drive Blower

[6] Blower Variable Frequency Drive Bypass

N = Not Installed
A = Automatic Electronic Bypass
M = Manual Electronic Bypass
U = Electronic Bypass Field Un-configured

[5] Network Module

N = Not Installed
L = LonTalk

FIGURE 42

M4 Unit Controller Configuration 2

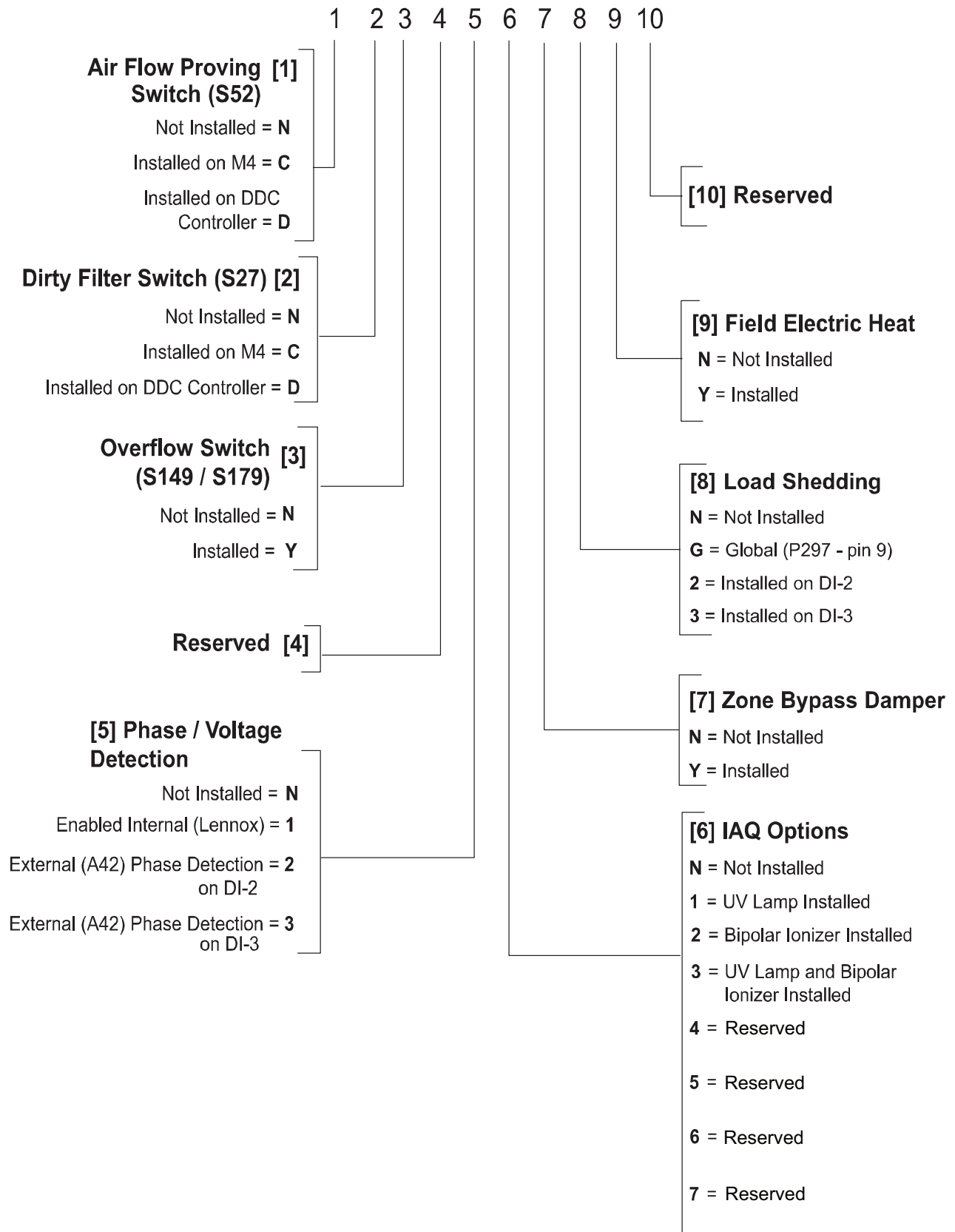

FIGURE 43

START-UP REPORT

Job Name: _____
 Store No. _____ Start-Up Date: _____
 Address: _____
 City: _____ State: _____
 Start-Up Contractor: _____
 Technician: _____
 Model No.: _____
 Serial No.: _____
 RTU No.: _____ Catalog No.: _____

Inspections and Checks			
Damage?	Yes	No	R454B <input type="checkbox"/>
If yes, reported to: _____			
Verify factory and field-installed accessories.			
Check electrical connections. Tighten if necessary.			
Supply voltage: L1-L2 _____ L1-L3 _____ L2-L3 _____			
If unit contains a 208-230/240 volt transformer:			
Check primary transformer tap <input type="checkbox"/>			
Transformer secondary voltage: _____			

Cooling Checks												
Compressor Rotation <input type="checkbox"/> Ambient Temp. _____ Return Air Temp. _____ Supply Air Temp. _____												
	Compressor Amps			Compressor Volts			Pressures		Condenser Fan Amps			CC Heater Amps
	L1	L2	L3	L1-L2	L1-L3	L2-L3	Disch.	Suct.	L1	L2	L3	L1
1												
2												
3												
4												

Blower Checks			
Pulley/Belt Alignment <input type="checkbox"/>	Blower Rotation <input type="checkbox"/>		
Set Screws Tight <input type="checkbox"/>	Belt Tension <input type="checkbox"/>		
Nameplate Amps: _____		Volts: _____	
Motor	Amps	Volts	
	L1 _____	L1-L2 _____	
	L2 _____	L1-L3 _____	
	L3 _____	L2-L3 _____	

Heating Checks - Electric							
Return Air Temp.: _____ Supply Air Temp.: _____							
Limits Operate: <input type="checkbox"/>							
	Amps						
	L1	L2	L3		L1	L2	L3
1				10			
2				11			
3				12			
4				13			
5				14			
6				15			
7				16			
8				17			
9				18			

Heating Checks - Gas		
Fuel type: Nat. <input type="checkbox"/> LP <input type="checkbox"/> Inlet Pressure: _____ in. w.c.		
Return Air Temp.: _____ Supply Air Temp.: _____		
Altitude: _____ Primary Limits Operate: <input type="checkbox"/>		
CO ₂ %: _____		
Gas Valve	Manifold Pressure	
	Low Fire	High Fire
GV1		
GV2		

Accessory Checks	
Power Exhaust Amps	
1 _____	2 _____ None <input type="checkbox"/>
Economizer Operation	
Min. Pos. <input type="checkbox"/>	Motor travel full open/close <input type="checkbox"/>

Control Type