

See unit nameplate for manufacturer's name and address.

# PACKAGED GAS UNITS KITS & ACCESSORIES



507578-02  
06/2026  
Supersedes 04/2021

## NATURAL TO LP (PROPANE) GAS CHANGEOVER KIT

### INSTALLATION INSTRUCTIONS FOR NATURAL TO LP (PROPANE) KIT USED WITH 156-360 PACKAGED GAS UNITS

#### **⚠ WARNING**

This conversion kit shall be installed by a qualified service agency in accordance with the manufacturer's instructions and all applicable codes and requirements of the authority having jurisdiction. If the information in these instructions is not followed exactly, a fire, an explosion or production of carbon monoxide may result causing property damage, personal injury or loss of life. The qualified service agency is responsible for the proper installation of this kit. The installation is not proper and complete until the operation of the converted appliance is checked as specified in the manufacturer's instructions supplied with the kit.

#### Shipping and Packing List

##### Package 1 of 1 contains:

- 2- Spring kits
- 1- Bag assembly containing:
  - 1-LP/propane conversion plate sticker
  - 1-Converter sticker
  - 1-Clear laminate sticker
- 1- Bag assembly containing
  - 11-Burner orifices .055" (39J84)
  - 9-Burner orifices .052 " (39J85)

#### Application

TABLE 1

Kit	156-36- (13-30 Ton) Application*
631604-01 39J84	Std. heat (Units with 6 burners) Use only 6 of the 11 orifices provided.
	High heat (Units with 11 burners)
631605-01 39J85	Med. heat (Units with 9 burners)

\*Two kits required

#### **⚠ WARNING**

Improper installation, adjustment, alteration, service or maintenance can cause property damage, personal injury or loss of life. Installation and service must be performed by a licensed professional HVAC installer or equivalent, service agency, or the gas supplier

#### **⚠ CAUTION**

As with any mechanical equipment, contact with sharp sheet metal edges can result in personal injury. Take care while handling this equipment and wear gloves and protective clothing.

#### Requirements

This conversion kit shall be installed by a qualified service agency. A qualified service agency is any individual, firm, corporation or company which either in person or through a representative is engaged in and is responsible for the connection, installation, repair or servicing of gas utilization equipment or accessories, who is experienced in such work, familiar with all precautions required, and has complied with all the requirements of the authority having jurisdiction.

**Canadian installations only** - The conversion shall be carried out in accordance with the requirements of the Provincial authorities having jurisdiction and in accordance with the requirements of the CAN/CGA-B149.1 and .2 Installation Code.

#### Installation

**IMPORTANT-** The gas supply shall be shut off prior to disconnecting the electrical power, before proceeding with this conversion.

- 1 - Turn main manual shut-off valve off and turn off electrical supply to unit. Set thermostat to "Off" position.
- 2 - Remove or open burner compartment access panel(s). Close manual knob on gas valve or turn switch off.



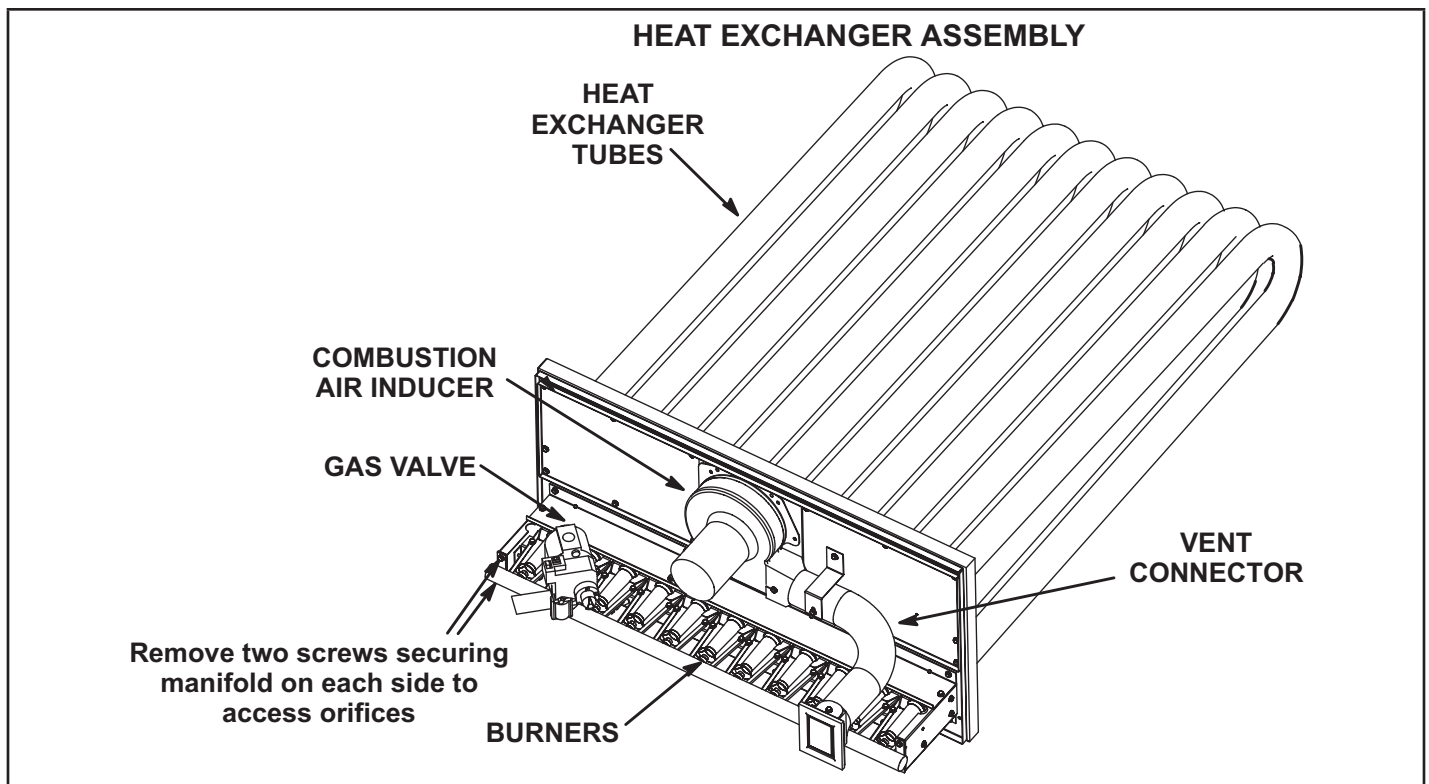

FIGURE 1

- 3 - Label and disconnect wiring to gas valve. Disconnect gas supply piping to gas valve if installed.
- 4 - Remove and retain four screws securing manifold to burner box. See FIGURE 1.
- 5 - Remove orifices from manifold and install the orifices provided in kit. When converting units with standard heat, use only 6 of the 11 orifices provided.

**CAUTION** - Tighten orifices with pipe threads to 6.25 ft.lbs. Do not overtighten.

**IMPORTANT** - Do not use thread compound on gas orifices.

- 6 - Secure manifold to burner box with four retained screws.
- 7 - Two spring kits are provided; use 10M8201 on Honeywell gas valve and 103191-01 on White Rodgers 36H27 modulating gas valve.
- 8 - Install the spring kit. Refer to FIGURE 2 or FIGURE 3 and manufacturer's instructions packaged with spring kit.
- 9 - Connect previously labeled wires to gas valve and connect gas supply to gas valve.
- 10 - Turn manual main shut-off valve on.
- 11 - Make a check mark in the appropriate box on the conversion sticker corresponding to unit model number shown on nameplate. Affix appropriate conversion sticker near unit nameplate. Place clear laminate over sticker.
- 12 - Complete installer information on converter sticker and affix to vestibule panel.
- 13 - Affix gas valve conversion sticker (found in conversion kit) on gas valve.

- 14 - Follow Start-up and Adjustment sections to place furnace in operation.

#### Converting the Honeywell VR8205/8305 Gas Valve (Natural to LP/Propane)

1. Turn off the gas supply to the unit.
2. Remove the pressure regulator cover assembly. See the gas valve illustration below.
3. Remove the existing stem/spring assembly.
4. Insert the replacement stem/spring assembly.
5. Replace the pressure regulator cover assembly and tighten the screws.
6. Apply the conversion label to the gas control.

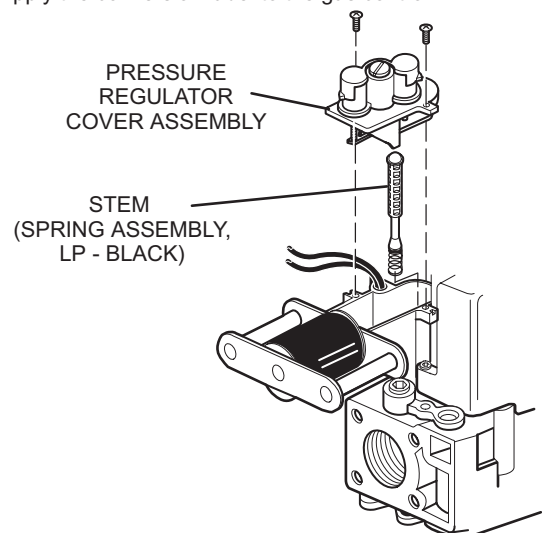

FIGURE 2

### Converting the White Rodgers 36H54 Gas Valve (Natural to LP/Propane)

- 1- Turn off the gas supply to the unit.
- 2- Remove both regulator cover screws.
- 3- Remove both regulator adjustment screws (beneath the cover screws).
- 4- Remove both **NATURAL GAS** regulator springs (color-coded silver / plain) from regulator sleeves.
- 5- Insert the LP regulator springs (provided in the conversion kit and color-coded white) into the regulator sleeves.
- 6- Replace the **HIGH** regulator adjustment screw and adjust approximately 12 turns to the bottom stop.
- 7- Replace the **LOW** regulator adjustment screw and adjust approximately 8 turns.

**NOTE - If the converted LP low regulator setting is less than 5.0" w.c., use the original natural gas spring.**

- 8- Adjust both outlet pressures to the appliance manufacturer's requirements.
- 9- Replace both regulator cover screws.
- 10- Attach the **WARNING** label (provided in the kit) to the gas valve where it can be readily seen. Also attach the small round LP labels to the top of the regulator cover screws.

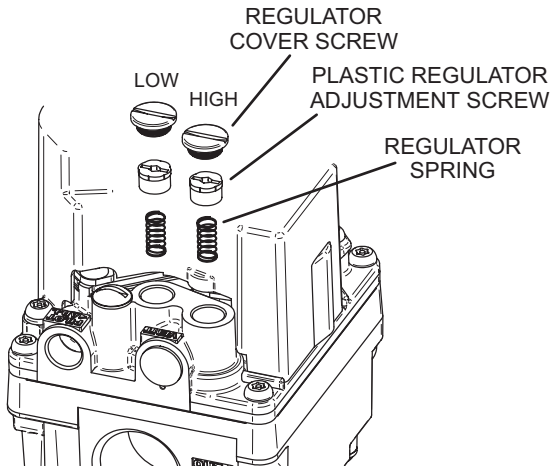

FIGURE 3

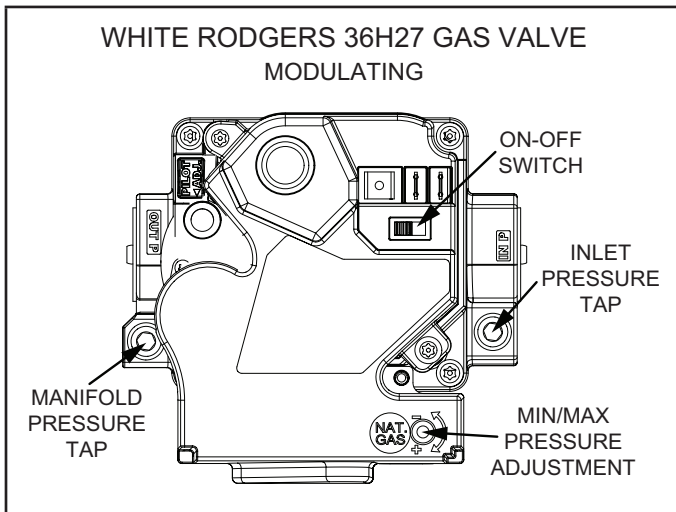

FIGURE 4

### 36H27 MODULATING GAS VALVE

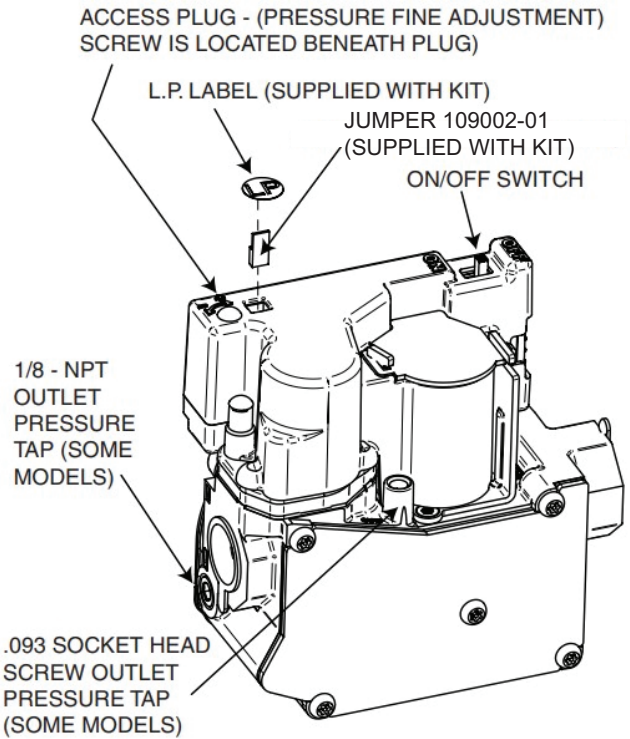

FIGURE 5

### 36H27 Valves (Modulating)

Locate the Jumper Kit specifically for the 36H27 modulating valve. The kit package should have the manufacturer's part number (F92-1021 or 109002-01) on the label. Two kits are available for each side of the heating assembly. Follow the manufacturer's instructions for installing the jumper plug and LP labels. See FIGURE 4 for reference.

## Start-Up And Adjustments

### **WARNING**



Danger of explosion. Can cause injury or death. Do not attempt to light manually. Unit has a direct spark ignition system.

#### **A-To place unit in operation:**

- 1 - Set thermostat to "Off" position. Close manual knob on gas valve or turn switch off.
- 2 - Wait five minutes. Open manual knob on gas valve or turn switch on. Replace burner compartment access panel.
- 3 - Restore electrical supply to unit and set fan switch to "Auto" or "On." Move system selection switch to "Heat" and adjust thermostat setting above room temperature.
- 4 - The ignition sequence will start.
- 5 - If burners do not light first time (gas line not fully purged), ignition system will attempt to light two more times before locking out gas valve operation.
- 6 - If lockout occurs, repeat steps 1, 2 and 3 above.

#### **B-To shut down unit operation:**

- 1 - Set thermostat selection switch to "Off" position. Remove burner compartment access panel. Turn manual knob on gas valve to "Off" position or turn switch off.
- 2 - Replace burner access panel.

#### **C-Heating Adjustment**

Check gas line pressure with unit firing at maximum rate. A minimum of 10.8" w.c., and a maximum of 13.5" w.c. should be maintained. Manifold pressure is preset at 10.5" w.c. No adjustment should be necessary. On multiple unit installations, each unit should be checked in sequence beginning with the one closest to the supply gas main and progressing to the one furthest from the main.