

# ML196UHE(K)

MERIT® SERIES

Upflow / Horizontal | Constant Torque Blower | Refrigerant Detection | 60Hz



RESIDENTIAL  
PRODUCT SPECIFICATIONS (EHB)

AFUE - 96%

Input - 30,000 to 132,000 Btuh  
Nominal Add-on Cooling - 1.5 to 5 Tons

**MERIT**®  
SERIES





**QUALIFIED ONLY IN**  
**U.S. SOUTH:** AL, AZ, AR, CA, DC, DE, FL, GA, HI, KY, LA, MD, MS, NV, NM, NC, OK, SC, TN, TX, VA



ENERGY STAR

## MODEL NUMBER IDENTIFICATION

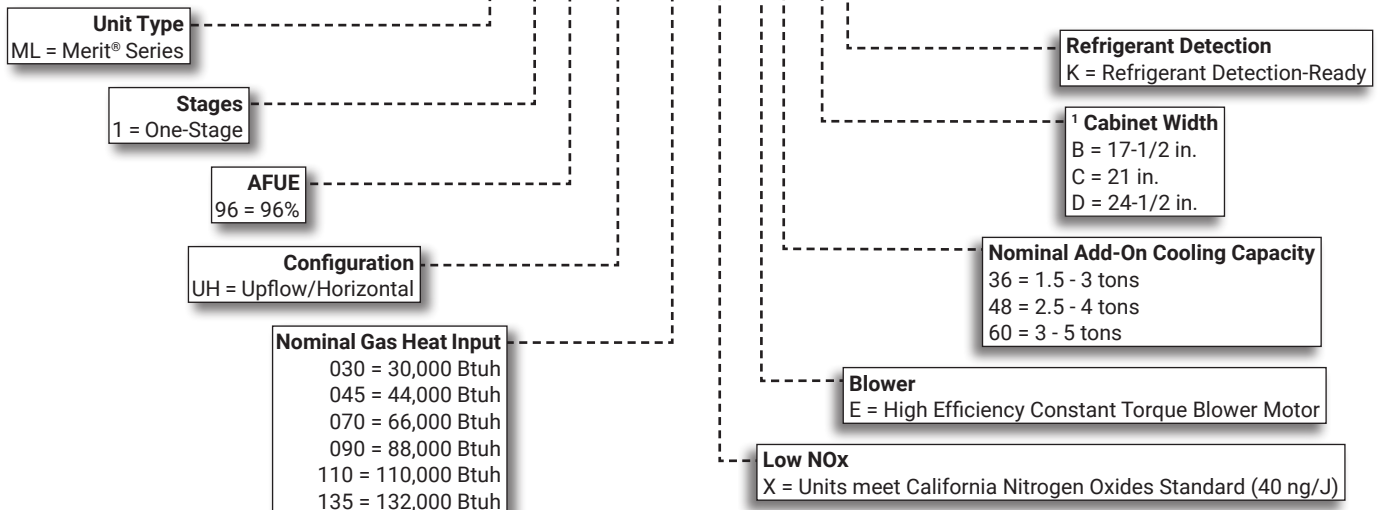
**ML 1 96 UH 070 X E 36 B K**



<sup>1</sup> Indoor coils with the same letter designation physically matches the furnace.

## FEATURE HIGHLIGHTS

1. Lennox Duralok Plus™ Heat Exchanger
2. Secondary Heat Exchanger
3. Inshot Burners
4. Gas Control Valve
5. Combustion Air Inducer
6. Flame Rollout Switch
7. SureLight® Integrated Furnace Control
8. Power Saver™ Constant Torque Blower
9. Insulated Cabinet
10. Safety Interlock Switch
11. Gas Piping And Electrical Inlets

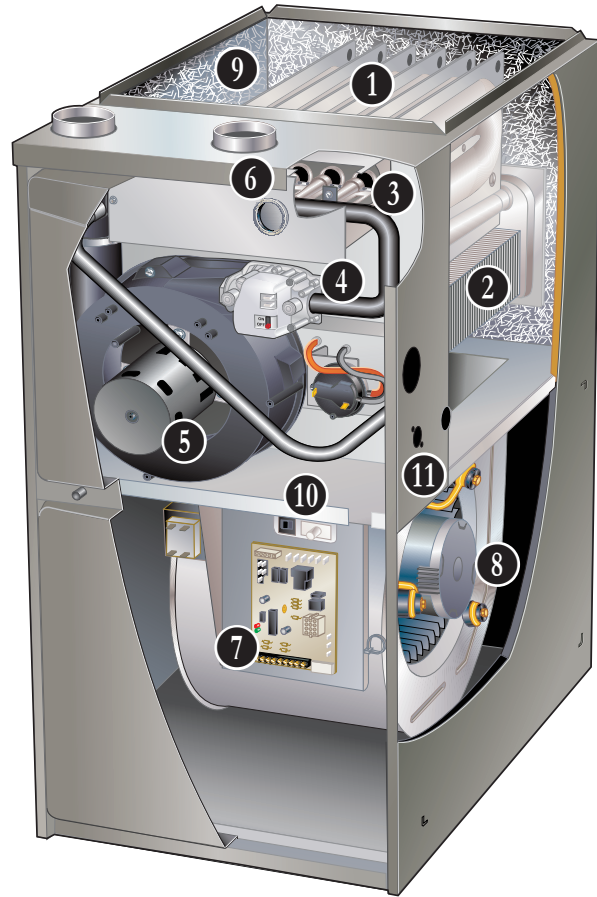

## CONTENTS

Blower Data . . . . .	26
Approvals And Warranty . . . . .	3
Control Options . . . . .	9
Dimensions . . . . .	19
- Furnace/Coil Combined . . . . .	22
- Optional Accessories . . . . .	21
- Optional Accessories - Venting . . . . .	23
- Unit - Horizontal Position . . . . .	20
- Unit - Upflow Position . . . . .	19
Features . . . . .	3
Gas Heat Accessories . . . . .	13
High Altitude Derate . . . . .	13
Indoor Air Quality Product Options . . . . .	8
Installation Clearances . . . . .	13
Model Number Identification . . . . .	1
Optional Accessories . . . . .	12
Specifications . . . . .	11
Vent Lengths . . . . .	15
- Exhaust Or Intake . . . . .	15
- Exhaust Using Ventilated Attic/Crawlspace Intake Air . . . . .	17
- Uninsulated Exhaust Pipe In Unconditioned Space . . . . .	18

## APPROVALS AND WARRANTY

### APPROVALS

- AHRI Certified
- Tested and rated according to US DOE test procedures and FTC labeling regulations
- ENERGY STAR® units are certified only in the U.S. South in certain states and are designed to use less energy, help save money on utility bills, and help protect the environment
- ISO 9001 Registered Manufacturing Quality System
- Blower data from unit tests conducted in Lennox Laboratory air test chamber
- All models meet UL 60335-2-40 Refrigerant Detector Requirements

**NOTE** - This furnace has not been CSA International design certified for installation in mobile homes, recreational vehicles, or outdoors.

### California Only

- This furnace **does not meet** the South Coast Air Quality Management District (SCAQMD) Rule 1111 and San Joaquin Valley Air Pollution Control District (SJVAPCD) Rule 4905 NOx emission limit (14 ng/J) and cannot be installed within the SCAQMD, SJVAPCD and Bay Area
- Approved by the California Energy Commission and meets California Nitrogen Oxides Standard (NOx) limits of 40 ng/J

### WARRANTY

- Duralok Plus™ Aluminized Steel Heat Exchanger:
  - Limited twenty year in residential applications
  - Limited ten years in non-residential applications
- All other covered components:
  - Limited five years in residential installations
  - Limited one year in non-residential installations

**NOTE** - Refer to Lennox® Basic Limited Warranty at [www.Lennox.com](http://www.Lennox.com) for additional details.

## FEATURES

### APPLICATIONS

- Input capacities of 30,000, 44,000, 66,000, 88,000, 110,000 and 135,000 Btuh
- Energy efficiency (AFUE) - 96%
- Compact cabinet for upflow, horizontal-left or horizontal-right applications without any modifications
- Lennox add-on indoor coils, high-efficiency air cleaners and humidifiers can easily be added to furnace
- Shipped factory assembled with all controls installed and wired
- Factory test operated to ensure proper operation

### HEATING SYSTEM

- 1 **Lennox Duralok Plus™ Heat Exchanger Assembly**
  - Lennox developed heat exchanger assembly consists of primary heat exchanger and secondary condenser coil assembly
  - Main multi-pass crimped seam design clamshell type
  - Constructed of heavy-gauge, aluminized steel
  - Designed for normal expansion and contraction with maximum efficiency and minimum resistance to air flow

- 2
  - Secondary heat exchanger condenser coil constructed of aluminum fins fitted to stainless steel tubes
  - Coil is factory tested for leaks
  - Condensate drain header box assembly located on front of coil
  - Compact size permits low overall design of furnace cabinet
  - Laboratory life cycle tested in excess of industry standards

### Lennox Designed Header Box

- Header box on end of condenser coil collects flue condensate for disposal through condensate drains
- Drains are located on each side of the cabinet for easy field installation of condensate drain trap
- Only one drain is used, the other drain is sealed
- Condensate drain trap is included with the unit for field installation

## FEATURES

### HEATING SYSTEM (continued)

#### Lennox Designed Flue Condensate Trap Assembly

- Field installed outside the conditioned air stream
- Assembly can be mounted on either side of cabinet in upflow applications
- Assembly is mounted below the cabinet in horizontal applications
- Can also be mounted remotely (up to 5 ft. away) from unit
- See Dimension Drawing and Installation Instructions
- 90° street elbow furnished for ease of drain trap installation
- Drain connection can be made with field provided PVC pipe or PVC coupling
- Drain cap on trap allows easy cleaning and winterizing

### 3 Inshot Burners

- Aluminized steel inshot burners provide efficient, trouble-free operation
- Burner venturi mixes air and gas in correct proportion for proper combustion
- Burner assembly can be removed from the unit as a single component for ease of service

#### SureLight® Hot Surface Ignitor

- Tough, reliable, long-life, trouble-free performance
- Silicon nitride ignitor
- Cemented to steatite block for protection against current leakage
- Ignition leads are constructed of nickel plated copper and are enclosed in high temperature Teflon® insulation for dependable operation

### 4 Gas Control Valve

- 24 volt redundant combination gas control valve combines manual shut off switch (On-Off), automatic electric valve (dual) and gas pressure regulation into a compact combination control

### 5 Combustion Air Inducer

- Shaded pole heavy duty blower prepurges heat exchanger and safely vents flue products
- Operates only during heating cycle

#### Pressure Switch

- Proves Combustion Air Inducer operation before allowing gas valve to open

#### Limit Control

- Primary limit is accurately located on header box on all units
- Automatic reset

### 6 Flame Rollout Switches (2)

- Factory installed on the front of the burner box
- Switch provides protection from abnormal operating conditions
- Manual reset

### Optional Accessories

#### High Altitude Orifice Kits

- Required on all units for proper operation at altitudes from 7501 to 10,000 ft.
- Kits are available for natural gas and LPG/propane

#### High Altitude Pressure Switch Kit

- Required for proper unit operation on installations above 4500 ft.

#### Natural Gas to LPG/Propane Conversion Kit

- Required for field changeover from natural gas to LPG/Propane

#### LPG/Propane to Natural Gas Conversion Kit

- Required for field changeover from LPG/Propane to natural gas

#### Muffler (US Only)

- Significantly reduces outdoor operating sound levels
- Two-inch diameter muffler is optional for 030 through 110 input models

**NOTE** - Two-inch muffler is optional for the 110 input model with a maximum vent pipe length of up to 29 ft.  
Three-inch diameter muffler is optional for 110 input model.

**NOTE** - Three-inch muffler is optional for the 110 input model with a minimum vent pipe length of 30 ft.

- Installed vertically in the exhaust piping
- See Optional Accessory Dimension Drawing

### **DIRECT VENT / NON-DIRECT VENT SEALED COMBUSTION SYSTEM**

- Furnace features a "sealed combustion" system and can be installed in either Direct Vent or Non-Direct applications
- In Direct Vent applications, combustion air is supplied from outdoors and flue gases are discharged outdoors
- In Non-Direct Vent applications, combustion air is supplied from indoors and flue gases are discharged outdoors

**NOTE** - Lennox has approved the use of DuraVent® PolyPro® and Centrotherm InnoFlue® manufactured vent pipe and terminations as an alternative to PVC vent pipe. Must be ordered separately.  
Tested and listed to the ULC S636 standard in Canada

- The polypropylene venting system must follow the uninsulated and unconditioned space vent lengths listed in the table on Page 18
- Refer to the Installation Instructions for additional details

## FEATURES

### **DIRECT VENT / NON-DIRECT VENT SEALED COMBUSTION SYSTEM (continued)**

#### **Flue Coupling**

- Assists with exhaust flue piping connection and servicing
- Includes flexible one 2-inch rubber coupling and two adjustable bands
- Approved for all Lennox 90% furnaces

#### **Vent Termination Kits**

- Facilitates installation of combustion air intake pipe and flue exhaust pipe
- Refer to venting table in this bulletin to determine pipe size needed and proper termination kit required
- See Optional Accessories table and dimension drawings

#### **Concentric Termination Kit - Direct Vent Applications**

- 2 or 3 inch kit contains concentric termination assembly, reducer bushing and 45° elbow
- 2 inch kit for -030-045-070 models contains an outdoor exhaust accelerator
- Kit requires single hole penetration of roof or wall for installation
- Roof Termination Flashing Kit is available for use with 2 inch Kits
- CSA certified

#### **Flush-Mount Termination Kit**

- Kit contains flush-mount termination, accelerator, mounting template and hardware
- Kit may be used with 2, 2-1/2 or 3 in. pipe

#### **Wall Assembly Termination Kits**

#### **Close Couple (US Only) - Direct Vent Applications**

- 2 or 3 inch kit consists of close-couple, side-by-side PVC piping with galvanized steel wall cover plate
- Seals and isolates intake and exhaust piping penetration of wall
- Piping spacing and length is sized for proper wall installations
- CSA certified

#### **Close Couple WTK (Canada Only) - Direct Vent Applications**

- 2 or 3 inch kit contains one insulated faceplate, one insulated exhaust pipe, elbow and fittings

**NOTE** - Maintain a maximum of 6 inches between the inlet and outlet openings in the installation of the pipes.

#### **Roof Termination Flashing Kit**

- For vertical venting through a roof
- 2 or 3 inch kit contains two neoprene rubber roof flashings
- Vent pipe and insulation not furnished
- Flashing Kit can also be used with Concentric Vent Termination Kits used in vertical venting rooftop applications

## CONTROLS

### **7 SureLight® Integrated Furnace Control**

- Contains all necessary controls and relays to operate furnace
- Combustion air inducer is operated by the integrated furnace control. Prior to ignition, a pre-purge cycle for 15 seconds is initiated
- After the main burners are turned off, a post-purge cycle for 5 seconds is run
- Flame sensor assures safe and reliable operation
- Should loss of flame occur, the integrated furnace control will initiate 4 re-attempts at ignition before locking out unit operation for 60 minutes
- Watchguard type circuit automatically resets ignition controls after one hour of continuous thermostat demand after unit lockout, eliminating nuisance calls for service
- Display LED - Seven segment LED displays numeric information related to diagnostics as well as system operation and status
  - Diagnostic codes are held in non-volatile memory, immune from power interruptions
  - Holds up to ten diagnostic codes in order of occurrence for recall on demand
  - Port on blower door allows for easy viewing
- Fan control consists of adjustable blower timed-off delay (60, 90, 120, 180 seconds - factory setting 120 seconds) and fixed blower timed-on delay (30 seconds heating, 2 seconds cooling)
- For air-conditioning applications, blower is automatically energized on thermostat demand for cooling
- Two accessory terminals furnished for additional power supply requirements for 120 volt (less than 1 amp) power humidifiers and powered air cleaners
- One additional terminal is furnished for power supply requirements for 24V (less than 0.5 amp) low voltage accessories
- Ignition control has a single red LED to indicate status

#### **Twinning**

- Terminal furnished on furnace control for twinning two furnaces together

#### **24 Volt Transformer (40VA)**

- Furnished and factory installed on outside of control box
- Circuit breaker (furnished) is wired in series

#### **Field Wiring Make-Up Box**

- Furnished for line voltage wiring
- Factory installed internally on left side of furnace
- Box may be installed internally on right side of furnace

## FEATURES

### **CONTROLS (Continued)**

#### **Refrigeration Detection System (RDS)**

(Part of the SureLight® Integrated Furnace Control)

- Complies with UL 60335-2-40 approved standard
- Required for all systems using R-454B refrigerant
- Plug-in connection to the RDS Coil Sensor
- Supports up to two RDS Coil Sensors (factory setting)
- Used as an interface between indoor unit and thermostat to control system
- Ensures safe operation for systems equipped with R-454B refrigerant
- If R-454B refrigerant is detected, the refrigerant detection system will stop compressor and/or heating operation and operate the blower to reduce concentrations in the conditioned space
- Once safe levels are reached the HVAC system will resume normal operation
- Low GWP test button for troubleshooting
- Alarm/Zone relay interface can trigger an external alarm if R-454B refrigerant is detected and open all zone dampers (if part of a zoning system) if R-454B refrigerant is detected
- Power is disabled to non-communicating thermostats to prevent demand if R-454B refrigerant is detected
- On system start-up blower will run for five minutes and any thermostat demands are disabled

#### **Optional Accessories**

##### **Thermostat**

- Thermostat is not furnished with unit
- See Page 9

##### **Blower Relay Kit**

(For Use With Two-Stage Outdoor Units)

- Allows furnace blower speed changes when matched with two-stage air conditioners or heat pumps

##### **Transformer (75VA)**

- Recommended when furnace is used with zoning or dual-fuel systems and other 24V accessories requiring a higher VA rating
- Circuit breaker (furnished) is wired in series
- Replaces the standard 40VA transformer

### **BLOWER**

- Direct drive blower
- Statically and dynamically balanced
- Resiliently mounted
- Blower assembly easily removed for servicing

#### **8 Power Saver™ Constant Torque Blower Motor**

- DC Brushless Motor
- High Efficiency Constant Torque
- ECM (Electronically Commutated Motor)
- Motor is programmed to provide constant torque at each of the selectable speeds
- Motor is controlled by the Integrated Furnace Control
- Blower speeds are easily changed on the integrated furnace control
- See Blower Data tables

### **CABINET**

- Low-profile, narrow width allows easy installation
- Heavy-gauge, cold rolled steel construction
- Pre-painted cabinet finish
- Flanges provided on supply air opening for ease of plenum connection or alignment with indoor coil
- 9** • Insulated with foil faced insulation on sides and back of heating compartment
- Sealed blower compartment
- Complete service access
- 10** • Safety interlock switch automatically shuts off power to unit when blower compartment access door is removed
- 11** • Gas piping and electrical inlets are provided in both sides of cabinet

#### **Low Leakage Cabinet**

- All models have less than 2% air leakage
- Meets ANSI/ASHRAE Standard 193-2010 "Method of Test for Determining the Air Tightness of HVAC Equipment"

## FEATURES

### **CABINET (continued)**

#### **Bottom/Side Return Air Entry:**

- Upflow/horizontal with bottom return air entry:
  - Remove furnished bottom seal panel from cabinet
- Upflow only with side return-air entry:
  - Corners are marked on either side of cabinet for return air cut-out
- See dimension drawings

**NOTE** - 60C and 60D size units that require air volumes over 1800 cfm must have one of the following:

- Single side return air and Optional Return Air Base with transition that must accommodate required 20 x 25 x 1 inch air filter to maintain proper velocity
- Bottom return air
- Return air from both sides
- Bottom and one side return air
- See Blower Performance Tables for additional information

#### **Coil Match-Up**

- All furnaces exactly match Lennox cased upflow indoor coils and horizontal indoor coils with same letter designation (A, B, C, D) in model number
- No adaptor required
- Engaging holes furnished on cabinet for alignment
- Lennox uncased coils match furnaces without any overhang but require an optional adaptor base or field fabricated transition to match furnace opening
- See coil bulletin for additional information

### **Optional Accessories**

#### **Condensate Drain Heat Cable Kits**

- Self-limiting wattage heat cable prevents condensate drain from freezing in unconditioned areas
- Available in 6 or 24 ft. lengths

#### **Horizontal Suspension Kit**

- Provides suspension of unit and indoor coil in horizontal applications
- Allows complete service access
- Consists of corner mounted hanging brackets with vibration isolators, return air end support rail and hardware for assembly
- Metal hanging straps must be field provided

#### **Crawl Space Vent Drain Kit**

- Allows venting through a crawl space for upflow and horizontal applications
- Includes 2 or 3 in. sanitary tee, 2 in. PVC assembly, PVC boot and clamp
- Kit for Canada is certified to ULC S636

#### **Return Air Base**

**NOTE** - On furnaces with side return air and condensate trap on the same side of the cabinet, a field fabricated transition or Return Air Base is required when using an IAQ product higher than 14-3/16 inches installed next to the unit and serviced from the front. IAQ products higher than 20 inches require a field fabricated transition.

**NOTE** - Must be used for 60C size models with air volumes over 1800 cfm in upflow applications when only one side return is required.

- Cabinet is shipped flat for easy field assembly
- Pre-painted steel to match the furnace
- See Dimension Drawing

### **Optional Accessories (continued)**

#### **High Performance Economizer (Commercial Applications Only)**

- Designed for applications requiring outdoor air to be utilized in a commercial HVAC system
- Allows the entry of fresh outdoor air for free cooling, reducing the requirement for mechanical cooling
- Heavy gauge galvanized steel cabinet lined with thick fiberglass insulation
- Mixed air sensor, outdoor air sensor and 24VAC transformer furnished
- Approved for California Title 24 building standards
- ASHRAE 90.1-2010 compliant
- See separate Product Specifications bulletin for additional information and available control and sensor options.

#### **FILTER (not furnished)**

- Filter and provisions for external mounting must be field provided

### **Optional Accessories**

#### **Air Filter and Rack Kit for Horizontal Return Air (End) Applications**

- Washable or vacuum cleanable polyurethane frame type filter and external end return air rack
- Rack has filter door for servicing
- Flanges on rack for duct connection
- Field installed
- See dimension drawing

#### **Air Filter and Rack Kit for Upflow Side Return Air**

**NOTE** - Not for use with Return Air Base

- Washable or vacuum cleanable polyurethane frame type filter and external side return air rack available for field installation
- Available in single and ten pack kits
- Rack has filter door for servicing
- Flanges on rack for duct connection
- Field installs on either side of unit cabinet
- See dimension drawing

## INDOOR AIR QUALITY PRODUCT OPTIONS

### Healthy Climate® PureAir® Air Purification System

- Filtration - The Carbon Clean 16® (MERV 16) media filter captures more than 95% of particles 0.3 microns and larger and more than 90% of particles 0.01 microns and larger
- Highest airflow performance and lowest pressure drop when compared to a leading brand.
- Long life filters up to 1 year



### Healthy Climate® Media Air Cleaner

- High performance in a narrow 7 in. cabinet
- Available with MERV 11, 13, or 16 rated filters
- Multi-position heavy gauge steel cabinet will support furnace/coil or air handler and associated duct work
- Tool-less entry
- Tool-less assembly for quick installation



### Healthy Climate® Whole Home In Duct Air Purifiers

- Compact Duct Mounted Design
- Effective against odors and VOC's
- Certified Ozone free
- UVC lamp and carbon cells



### Healthy Climate® Ultraviolet Germicidal Lights

- Compact duct mounted design
- Single or dual applications
- Certified ozone free
- Effective against odors to help keep the system clean
- Safety Interlocks (Additional UVC Compliance Kit for UL 60335-2-40 is available for A2L applications)
- Low power consumption
- Available for 24V or 110/230V
- Up to 1340 microwatts /cm<sup>2</sup> output (dual lamp model)



**NOTE** - Please refer to the individual Product Specifications for these products for full information.

**NOTE** - Please refer to the individual Product Specifications for these products for full information.

## CONTROL OPTIONS

### E40 Smart Wi-Fi Thermostat

- 3 Htg.-2 Clg.
- 7-day, universal, programmable, touchscreen thermostat
- Controls dehumidification during cooling mode and humidification during heating mode
- Smooth Setback Recovery and compressor short-cycle protection
- One-Touch Away Mode, Smart Away™ (geo-fencing), equipment maintenance reminders and scheduling
- Smart home automation compatible with Amazon Alexa®, Google Assistant, Control4®, Building36® and Matter
- Lennox® Home App controls temperature, fan operation, set programs/schedules and set Away mode on a smartphone
- Lennox Smart Tech App allows the installer to commission the system and remotely turn the system on and off during setup or service call on a smartphone



### M40 Smart Wi-Fi Thermostat

- 3 Htg.-2 Clg.
- 7-day, universal, programmable, touchscreen thermostat
- Smooth Setback Recovery and compressor short-cycle protection
- One-Touch Away Mode, Smart Away™ (geo-fencing), equipment maintenance reminders and scheduling
- Smart home automation compatible with Apple HomeKit™, Amazon Alexa®, Google Assistant and Matter
- Lennox® Home App controls temperature, fan operation, set programs/schedules and set Away mode on a smartphone
- Lennox Smart Tech App allows the installer to commission the system and remotely turn the system on and off during setup or service call on a smartphone



### L40 Smart Wi-Fi Thermostat

- 2 Htg.-1 Clg.
- 7-day, universal, programmable, touchscreen thermostat
- Provides temperature control for gas, electric and heat pumps for single-stage heating or cooling systems (including dual-fuel operation)
- One-Touch Away Mode, Smart Away™ (geo-fencing), equipment maintenance reminders and scheduling
- Smooth Setback Recovery and compressor short-cycle protection
- Smart home automation compatible with Amazon Alexa®, Google Assistant, Control4®, Building36® and Matter
- Lennox® Home App controls temperature, fan operation, set programs/schedules and set Away mode on a smartphone
- Lennox Smart Tech App allows the installer to commission the system and remotely turn the system on and off during setup or service call on a smartphone



**NOTE** - Please refer to the individual Product Specifications for these products for full information.

## INDOOR AIR QUALITY PRODUCT OPTIONS - ORDERING

**NOTE - Refer to the individual Product Specifications documents for additional accessories and maintenance items.**

Description	Dimensions	Furnace Width	Order Number
<b>PureAir® S Air Purification System</b>			
PCO3S-16-16	17-1/2 x 8-3/4 x 26-1/2	A/B/C	Y8904
PCO3S-20-16	21-1/8 x 8-3/4 x 26-1/2	C/D	Y8903
<b>Healthy Climate® Media Air Cleaner</b>			
HCC16-28 (Cabinet)	17-1/2 x 28-1/2 x 7	A/B/C	Y2920
HCC16-28 (Cabinet) 4-pack	17-1/2 x 28-1/2 x 7	---	Y2921
HCF16-16 (Filter) MERV 16	16 x 25 x 5	---	X6672
HCXF16-16 (Expandable Filter) MERV 16	16 x 25 x 5	---	X8306
HCF16-13 MERV 13	16 x 25 x 5	---	19L16
HCF16-11 (Filter) MERV 11	16 x 25 x 5	---	X6670
HCXF16-11 (Expandable Filter) MERV 11	16 x 25 x 5	---	X8303
HCC20-28 (Cabinet)	21 x 28-1/2 x 7	C/D	X6661
HCC20-28 (Cabinet) 4-pack	21 x 28-1/2 x 7	---	X7751
HCF20-16 (Filter) MERV 16	20 x 25 x 5	---	X6675
HCXF20-16 (Expandable Filter) MERV 16	20 x 25 x 5	---	X8307
HCF20-13 MERV 13	20 x 25 x 5	---	19L17
HCF20-11 (Filter) MERV 11	20 x 25 x 5	---	X6673
HCXF20-11 (Expandable Filter) MERV 11	20 x 25 x 5	---	X8304
<b>Healthy Climate® Whole Home In Duct Air Purifiers</b>			
HCWHAP1	8 x 7 x 16.5	---	23V99
<b>Healthy Climate® Ultraviolet Germicidal Lights</b>			
UVC-24V (24V) 17-1/2 in.	Ballast 4-3/4 x 2-1/4 x 2	---	X9423
UVC-41W-S (110/230V) 17-1/2 in.	Ballast 11-3/4 x 2-3/4 x 1-5/8	---	X9424
UVC-41W-D (110/230V) 17-1/2 in.	Ballast 11-3/4 x 2-3/4 x 1-5/8	---	X9425
<b>CONTROLS - ORDERING</b>			
E40 Smart Wi-Fi Thermostat	3-3/8 x 5-3/8 x 1	---	30L26
Lennox® Smart Room Sensor	4 x 5-1/2 x 3	---	22V25
Lennox® Smart Air Quality Monitor	3-5/8 x 4-3/8 x 1-3/8	---	21P02
Lennox® Wireless Extender	4 x 5-1/2 x 2-1/2	---	22V26
L40 Smart Wi-Fi Thermostat	2-13/16 x 2-13/16 x 1/4	---	27V51
M40 Smart Wi-Fi Thermostat	3-5/16 x 4-5/16 x 7/8	---	30L27
<b>Thermostat Accessories</b>			
¹ Discharge Air Temperature Sensor (For S40, E40)			88K38
² Remote Outdoor Air Temperature Sensor (For E40/L40) (For dual-fuel and Humiditrol®)			X2658

¹ Optional for service diagnostics (E40).

² Remote Outdoor Air Temperature Sensor is used with conventional (non-Lennox® Communicating) outdoor units (sensor is furnished with Lennox® Communicating outdoor units). Allows the thermostat to display outdoor temperature. Required in dual-fuel and Humiditrol® applications.

## SPECIFICATIONS

Gas Heating Performance		Model	ML196UH 030XE36BK	ML196UH 045XE36BK	ML196UH 070XE36BK	ML196UH 070XE48BK	ML196UH 090XE36CK
		<sup>1</sup> AFUE	96%	96%	96%	96%	96%
		Input - Btuh	30,000	44,000	66,000	66,000	88,000
		Output - Btuh	29,000	43,000	64,000	64,000	86,000
		Temperature rise range - °F	25 - 55	35 - 65	35 - 65	30 - 60	45 - 75
		Gas Manifold Pressure (in. w.g.) Nat. Gas / LPG/Propane	3.5 / 10	3.5 / 10	3.5 / 10	3.5 / 10	3.5 / 10
		High static - in. w.g.	0.5	0.5	0.5	0.5	0.5
<b>Energy Star® Certified</b>			Yes	Yes	Yes	Yes	Yes
<b>Connections</b>	Intake / Exhaust Pipe (PVC)		2 / 2	2 / 2	2 / 2	2 / 2	2 / 2
	Gas pipe size IPS		1/2	1/2	1/2	1/2	1/2
	Condensate Drain Trap (PVC pipe) - i.d.		3/4	3/4	3/4	3/4	3/4
	with furnished 90° street elbow with field supplied (PVC coupling) - o.d.		3/4 slip x 3/4 MIPT 3/4 slip x 3/4 MPT				
<b>Indoor Blower</b>	Wheel diameter x width - in.		10 x 8	10 x 8	10 x 8	11-1/2 x 10	10 x 8
	Motor Type		DC Brushless	DC Brushless	DC Brushless	DC Brushless	DC Brushless
	Motor output - hp		1/2	1/2	1/2	3/4	1/2
	Tons of add-on cooling		1.5 - 3	1.5 - 3	1.5 - 3	2.5 - 4	1.5 - 3
	Air Volume Range - cfm		175 - 1435	520 - 1345	550 - 1380	835 - 1855	460 - 1470
<b>Electrical Data</b>	Voltage		120 volts - 60 hertz - 1 phase				
	Blower motor full load amps		6.8	6.8	6.8	8.4	6.8
	Maximum overcurrent protection		15	15	15	15	15
<b>Shipping Data</b>	lbs. - 1 package		120	124	129	132	142

NOTE - Filters and provisions for mounting are not furnished and must be field provided.

<sup>1</sup> Annual Fuel Utilization Efficiency based on DOE test procedures and according to FTC labeling regulations. Isolated combustion system rating for non-weatherized furnaces.

## SPECIFICATIONS

Gas Heating Performance		Model	ML196UH 090XE48CK	ML196UH 090XE60CK	ML196UH 110XE60CK	ML196UH 135XE60DK
		<sup>1</sup> AFUE	96%	96%	96%	96%
		Input - Btuh	88,000	88,000	110,000	132,000
		Output - Btuh	86,000	86,000	107,000	127,000
		Temperature rise range - °F	50 - 80	35 - 65	45 - 75	45 - 75
		Gas Manifold Pressure (in. w.g.) Nat. Gas / LPG/Propane	3.5 / 10	3.5 / 10	3.5 / 10	3.5 / 10
		High static - in. w.g.	0.5	0.5	0.5	0.5
<b>Energy Star® Certified</b>			Yes	Yes	Yes	Yes
<b>Connections</b>	Intake / Exhaust Pipe (PVC)		2 / 2	2 / 2	2 / 2	2 / 2
	Gas pipe size IPS		1/2	1/2	1/2	1/2
	Condensate Drain Trap (PVC pipe) - i.d.		3/4	3/4	3/4	3/4
	with furnished 90° street elbow with field supplied (PVC coupling) - o.d.		3/4 slip x 3/4 MIPT 3/4 slip x 3/4 MPT			
<b>Indoor Blower</b>	Wheel diameter x width - in.		10 x 10	11-1/2 x 10	11-1/2 x 10	11-1/2 x 10
	Motor Type		DC Brushless	DC Brushless	DC Brushless	DC Brushless
	Motor output - hp		3/4	1	1	1
	Tons of add-on cooling		2.5 - 4	3-5	3 - 5	3-5
	Air Volume Range - cfm		760 - 1740	1050 - 2105	1055 - 2220	1310 - 2400
<b>Electrical Data</b>	Voltage		120 volts - 60 hertz - 1 phase			
	Blower motor full load amps		8.4	10.9	10.9	10.9
	Maximum overcurrent protection		15	15	15	15
<b>Shipping Data</b>	lbs. - 1 package		152	152	164	174

NOTE - Filters and provisions for mounting are not furnished and must be field provided.

<sup>1</sup> Annual Fuel Utilization Efficiency based on DOE test procedures and according to FTC labeling regulations. Isolated combustion system rating for non-weatherized furnaces.

## OPTIONAL ACCESSORIES

		"B" Width Models	"C" Width Models	"D" Width Models	
<b>CABINET ACCESSORIES</b>					
Horizontal Suspension Kit - Horizontal only		51W10	51W10	51W10	
Return Air Base - Upflow only		50W98	50W99	50W99	
High Performance Economizer (Commercial Only)		10U53	10U53	10U53	
<b>CONDENSATE DRAIN KITS</b>					
Condensate Drain Heat Cable	6 ft.	26K68	26K68	26K68	
	24 ft.	26K69	26K69	26K69	
Crawl Space Vent Drain Kit	US	51W18	51W18	51W18	
	Canada	15Z70	15Z70	15Z70	
<b>CONTROLS</b>					
Blower Relay Kit (for two-stage outdoor units)		85W66	85W66	85W66	
Transformer (75VA)		27J32	27J32	27J32	
<b>FILTER KITS</b>					
<sup>1</sup> Air Filter and Rack Kit	Horizontal (end)	87L96	87L97	87L98	
		Size of filter - in.	18 x 25 x 1	20 x 25 x 1	
	Side Return	Single	44J22	44J22	
		Ten Pack	66K63	66K63	
		Size of filter - in.	16 x 25 x 1	16 x 25 x 1	
<b>TERMINATION KITS</b>					
See Installation Instructions for specific venting information.					
Direct Vent	Concentric	US - 2 in.	71M80	69M29	---
		3 in.	---	60L46	60L46
		Canada - 2 in.	44W92	44W92	---
		3 in.	---	44W93	44W93
	Flush-Mount	US - 2, 2-1/2 or 3 in.	51W11	51W11	51W11
		Canada - 2, 2-1/2 or 3 in.	51W12	51W12	51W12
	Wall - Close Couple	US - 2 in.	22G44	---	---
		3 in.	44J40	44J40	44J40
	Wall - Close Couple WTK	Canada - 2 in.	30G28	---	---
		3 in.	81J20	81J20	81J20
	Roof Termination Flashing Kit (no vent pipe - 2 flashings)	2 in.	15F75	15F75	---
		3 in.	44J41	44J41	44J41
	<b>VENTING</b>				
Flue Coupling		2 in.	17H92	17H92	17H92

<sup>1</sup> Cleanable polyurethane frame type filter.

NOTE - Termination Kits (44W92, 44W93, 30G28, 51W12, 81J20) and Crawl Space Vent Drain Kit (15Z70) are certified to ULC S636 standard for use in Canada only.

## GAS HEAT ACCESSORIES

Input	High Altitude Pressure Switch Kit		Natural Gas to LPG/Propane Kit	LPG/Propane to Natural Gas Kit	Natural Gas High Altitude Orifice Kit	LPG/Propane High Altitude Orifice Kit	Muffler (US Only)
	4501 - 7500 ft.	7501 - 10,000 ft.	0 - 7500 ft.	0 - 7500 ft.	7501 - 10,000 ft.	7501 - 10,000 ft.	
030	11U66	11U69	17H63	N/A	14C90	17H66	15Y66 (2-inch)
045	11U66	11U69	11K49	73W81	73W37	11K44	15Y66 (2-inch)
070	11U70	11U68	11K49	73W81	73W37	11K44	15Y66 (2-inch)
090	11U70	11U64	11K49	73W81	73W37	11K44	15Y66 (2-inch)
110	11U70	11U64	11K49	73W81	73W37	11K44	<sup>1</sup> 15Y66 (2-inch) 16A56 (3-inch)
135	11U70	11U68	11K49	73W81	73W37	11K44	16A56 (3-inch)

<sup>1</sup> Two-inch diameter muffler (15Y66) is optional for 110 input model with a maximum vent pipe length of up to 29 ft.  
Three-inch diameter muffler (16A56) is optional for 110 input model with a minimum vent pipe length of 30 ft.

## HIGH ALTITUDE DERATE

NOTE - Units may be installed at altitudes up to 10,000 ft.

At altitudes above 4501 ft. the unit must be derated to match the manifold pressure information shown below.

Units installed at altitudes of 4501 to 10,000 ft. require a pressure switch change.

Units installed at altitudes of 7501 to 10,000 ft. require an orifice change.

See the Gas Heat Accessories table for ordering information.

NOTE - This is the only permissible derate for these units.

NOTE - In Canada, certification for installations at elevations over 4500 feet is the jurisdiction of local authorities.

Input	Gas	Manifold Pressure in. w.g.					Supply Line Pressure in. w.g.	
		0 - 4500 ft.	4501 - 5500 ft.	5501 - 6500 ft.	6501 - 7500 ft.	7501 - 10,000 ft.	0 - 10,000 ft.	
All Sizes	Natural	3.5	3.3	3.2	3.1	3.5	4.5	13.0
	LPG/Propane	10.0	9.4	9.1	8.9	10.0	11.0	13.0

## INSTALLATION CLEARANCES

Sides	<sup>1</sup> 0 inches (0 mm)
Rear	0 inches (0 mm)
Top/Plenum	1 inch (25 mm)
Front	0 inches (0 mm)
Front (service/alcove)	24 inches (610 mm)
Floor	<sup>2</sup> Combustible

NOTE - Air for combustion must conform to the methods outlined in the National Fuel Gas Code (NFPA 54/ANSI-Z223.1) or the National Standard of Canada CAN/CSA-B149.1 Natural Gas and Propane Installation Code".

NOTE - In the U.S. flue sizing must conform to the methods outlined in the current National Fuel Gas Code (NFPA 54/ANSI-Z223.1) or applicable provisions of local building codes. In Canada flue sizing must conform to the methods outlined in National Standard of Canada CAN/CSA-B149.1.

<sup>1</sup> Allow proper clearances to accommodate condensate trap and vent pipe installation.

<sup>2</sup> Do not install the furnace directly on carpeting, tile, or other combustible materials other than wood flooring.

## OUTDOOR TERMINATION KIT USAGE

Input Size	Vent Pipe Diameter (in.)	Standard Terminations				Concentric Terminations		
		Flush Mount Kit	Wall Kit		Field Fabricated Exhaust Accelerator Size Required	Concentric Kit		
			2 inch	3 inch		1-1/2 inch	2 inch	3 inch
			51W11 (US) 5 51W12 (CA)	22G44 (US) 5 30G28 (CA)		44J40 (US) 5 81J20 (CA)	71M80 (US) 5 44W92 (CA)	69M29 (US) 5 44W92 (CA)
<b>030/045</b>	<sup>1</sup> 1-1/2	<sup>4</sup> YES	YES	<sup>2</sup> YES	1-1/2 in.	<sup>3</sup> YES	---	---
	2	<sup>4</sup> YES	YES	<sup>2</sup> YES	1-1/2 in.	<sup>3</sup> YES	---	---
	2-1/2	<sup>4</sup> YES	YES	<sup>2</sup> YES	1-1/2 in.	<sup>3</sup> YES	---	---
	3	<sup>4</sup> YES	YES	<sup>2</sup> YES	1-1/2 in.	<sup>3</sup> YES	---	---
<b>070</b>	<sup>1</sup> 1-1/2	<sup>4</sup> YES	YES	<sup>2</sup> YES	1-1/2 in.	<sup>3</sup> YES	---	---
	2	<sup>4</sup> YES	YES	<sup>2</sup> YES	1-1/2 in.	<sup>3</sup> YES	---	---
	2-1/2	<sup>4</sup> YES	YES	<sup>2</sup> YES	1-1/2 in.	<sup>3</sup> YES	---	---
	3	<sup>4</sup> YES	YES	<sup>2</sup> YES	1-1/2 in.	<sup>3</sup> YES	---	---
<b>090</b>	2	<sup>4</sup> YES	---	YES	2 in.	---	YES	YES
	2-1/2	<sup>4</sup> YES	---	YES	2 in.	---	YES	YES
	3	<sup>4</sup> YES	---	YES	2 in.	---	YES	YES
<b>110</b>	2	YES	---	YES	2 in.	---	YES	YES
	2-1/2	YES	---	YES	2 in.	---	YES	YES
	3	YES	---	YES	2 in.	---	YES	YES
<b>135</b>	3	YES	---	YES	2 in.	---	---	YES

NOTE - Standard Terminations do not include any vent pipe or elbows external to the structure.

Any vent pipe or elbows external to the structure must be included in total vent length calculations. See Vent Length Tables.

<sup>1</sup> 2 inch to 1-1/2 inch reducer required, must be field provided.

<sup>2</sup> Requires field provided 1-1/2 in. outdoor exhaust accelerator.

<sup>3</sup> Concentric Kits **71M80** and **44W92** include 1-1/2 in. outdoor exhaust accelerator, required when used with 030, 045 and 070 input models. Accelerator is not used with 090 or 110 input models. When using 1-1/2 in. piping, the pipe must be transitioned to 2 in. pipe when used with the Concentric Kit.

<sup>4</sup> Flush Mount Kit **51W11** and **51W12** includes 1-1/2 in. outdoor exhaust accelerator, required when used with 030, 045, 070 and 090 input models. Accelerator is not used with 110 input models. When using 1-1/2 in. piping, the pipe must be transitioned to 2 in. pipe when used with the Flush Mount Kit.

<sup>5</sup> Termination Kits **30G28**, **44W92**, **44W93**, **51W12** and **81J20** are certified to ULC S636 standard for use in Canada only.

**VENT LENGTHS**

**EXHAUST OR INTAKE**

**STANDARD TERMINATION AT 0 - 2000 ft. ELEVATION**

Pipe Size		1-1/2 in.						2 in.					2-1/2 in.					3 in.				
Input		030	045	070	090	110	135	030/045	070	090	110	135	030/045	070	090	110	135	030/045	070	090	110	135
No. of 90 ELL	1	25	20	15	N/A	N/A	N/A	81	66	44	24	N/A	115	115	93	58	N/A	138	137	118	118	80
	2	20	15	10	N/A	N/A	N/A	76	61	39	19	N/A	110	110	88	53	N/A	133	132	113	113	75
	3	15	10	N/A	N/A	N/A	N/A	71	56	34	14	N/A	105	105	83	48	N/A	128	127	108	108	70
	4	10	N/A	N/A	N/A	N/A	N/A	66	51	29	N/A	N/A	100	100	78	43	N/A	123	122	103	103	65
	5	N/A	N/A	N/A	N/A	N/A	N/A	61	46	24	N/A	N/A	95	95	73	38	N/A	118	117	98	98	60
	6	N/A	N/A	N/A	N/A	N/A	N/A	56	41	19	N/A	N/A	90	90	68	33	N/A	113	112	93	93	55
	7	N/A	N/A	N/A	N/A	N/A	N/A	51	36	14	N/A	N/A	85	85	63	28	N/A	108	107	88	88	50
	8	N/A	N/A	N/A	N/A	N/A	N/A	46	31	N/A	N/A	N/A	80	80	58	23	N/A	103	102	83	83	45
	9	N/A	N/A	N/A	N/A	N/A	N/A	41	26	N/A	N/A	N/A	75	75	53	18	N/A	98	97	78	78	40
	10	N/A	N/A	N/A	N/A	N/A	N/A	36	21	N/A	N/A	N/A	70	70	48	13	N/A	93	92	73	73	35

NOTES - Additional vent pipe and long radius elbows (required) used to terminate vent pipe outside the structure must be included in the total vent length calculation.  
 Intake and exhaust pipes are sized separately.  
 Values in table are for separate intake or exhaust pipe lengths.  
 Both intake and exhaust pipe must be the same size diameter.

**STANDARD TERMINATION AT 2001 - 10,000 ft. ELEVATION**

Pipe Size		1-1/2 in.	2 in.									
Input		030	030/045	070				090			110	135
Elevation		---	2001-10,000 ft.	2001-3000 ft.	3001-4000 ft.	4001-10,000 ft.	2001-3000 ft.	3001-4000 ft.	4001-10,000 ft.	2001-10,000 ft.		
No. of 90 ELL	1	N/A	81	55	45	35	30	25	20	N/A	N/A	
	2		76	50	40	30	25	20	15	N/A	N/A	
	3		71	45	35	25	20	15	10	N/A	N/A	
	4		66	40	30	20	15	10	N/A	N/A	N/A	
	5		61	35	25	15	10	N/A	N/A	N/A	N/A	
	6		56	30	20	10	N/A	N/A	N/A	N/A	N/A	
	7		51	25	15	N/A	N/A	N/A	N/A	N/A	N/A	
	8		46	20	10	N/A	N/A	N/A	N/A	N/A	N/A	
	9		41	15	N/A	N/A	N/A	N/A	N/A	N/A	N/A	
	10		36	10	N/A	N/A	N/A	N/A	N/A	N/A	N/A	
Pipe Size		2-1/2 in.					3 in.					
Input		030/045	070	090	110	135	030/045	070	090	110	135	
Elevation		2001-10,000 ft.					2001-10,000 ft.					
No. of 90 ELL	1	115	110	67	53	N/A	138	137	118	118	80	
	2	110	105	62	48	N/A	133	132	113	113	75	
	3	105	100	57	43	N/A	128	127	108	108	70	
	4	100	95	52	38	N/A	123	122	103	103	65	
	5	95	90	47	33	N/A	118	117	98	98	60	
	6	90	85	42	28	N/A	113	112	93	93	55	
	7	85	80	37	23	N/A	108	107	88	88	50	
	8	80	75	32	18	N/A	103	102	83	83	45	
	9	75	70	27	13	N/A	98	97	78	78	40	
	10	70	65	22	N/A	N/A	93	92	73	73	35	

NOTES - Additional vent pipe and long radius elbows (required) used to terminate vent pipe outside the structure must be included in the total vent length calculation.  
 Intake and exhaust pipes are sized separately.  
 Values in table are for separate intake or exhaust pipe lengths.  
 Both intake and exhaust pipe must be the same size diameter.

**VENT LENGTHS**

**EXHAUST OR INTAKE**

**CONCENTRIC TERMINATION AT 0 - 2000 ft. ELEVATION**

Pipe Size		1-1/2 in.						2 in.					2-1/2 in.					3 in.				
Input		030	045	070	090	110	135	030/045	070	090	110	135	030/045	070	090	110	135	030/045	070	090	110	135
<b>No. of 90 ELL</b>	1	20	15	10	N/A	N/A	N/A	73	58	42	22	N/A	105	105	89	54	N/A	121	121	114	114	70
	2	15	10	N/A	N/A	N/A	N/A	68	53	37	17	N/A	100	100	84	49	N/A	116	116	109	109	65
	3	10	N/A	N/A	N/A	N/A	N/A	63	48	32	12	N/A	95	95	79	44	N/A	111	111	104	104	60
	4	N/A	N/A	N/A	N/A	N/A	N/A	58	43	27	N/A	N/A	90	90	74	39	N/A	106	106	99	99	55
	5	N/A	N/A	N/A	N/A	N/A	N/A	53	38	22	N/A	N/A	85	85	69	34	N/A	101	101	94	94	50
	6	N/A	N/A	N/A	N/A	N/A	N/A	48	33	17	N/A	N/A	80	80	64	29	N/A	96	96	89	89	45
	7	N/A	N/A	N/A	N/A	N/A	N/A	43	28	12	N/A	N/A	75	75	59	24	N/A	91	91	84	84	40
	8	N/A	N/A	N/A	N/A	N/A	N/A	38	23	N/A	N/A	N/A	70	70	54	19	N/A	86	86	79	79	35
	9	N/A	N/A	N/A	N/A	N/A	N/A	33	18	N/A	N/A	N/A	65	65	49	14	N/A	81	81	74	74	30
	10	N/A	N/A	N/A	N/A	N/A	N/A	28	13	N/A	N/A	N/A	60	60	44	N/A	N/A	76	76	69	69	25

NOTES - Additional vent pipe and long radius elbows (required) used to terminate vent pipe outside the structure must be included in the total vent length calculation.  
 Intake and exhaust pipes are sized separately.  
 Values in table are for separate intake or exhaust pipe lengths.  
 Both intake and exhaust pipe must be the same size diameter.

**CONCENTRIC TERMINATION AT 2001 - 10,000 ft. ELEVATION**

Pipe Size		1-1/2 in.	2 in.									
Input		030	030/045	070				090			110	135
Elevation		---	2001-10,000 ft.	2001-3000 ft.	3001-4000 ft.	4001-10,000 ft.	2001-3000 ft.	3001-4000 ft.	4001-10,000 ft.	2001-10,000 ft.		
<b>No. of 90 ELL</b>	1	N/A	73	50	40	30	25	20	15	N/A	N/A	
	2		68	45	35	25	20	15	10	N/A	N/A	
	3		63	40	30	20	15	10	N/A	N/A	N/A	
	4		58	35	25	15	10	N/A	N/A	N/A	N/A	
	5		53	30	20	10	N/A	N/A	N/A	N/A	N/A	
	6		48	25	15	5	N/A	N/A	N/A	N/A	N/A	
	7		43	20	10	N/A	N/A	N/A	N/A	N/A	N/A	
	8		38	15	5	N/A	N/A	N/A	N/A	N/A	N/A	
	9		33	10	N/A	N/A	N/A	N/A	N/A	N/A	N/A	
	10		28	5	N/A	N/A	N/A	N/A	N/A	N/A	N/A	
Pipe Size		2-1/2 in.					3 in.					
Input		030/045	070	090	110	135	030/045	070	090	110	135	
Elevation		2001-10,000 ft.					2001-10,000 ft.					
<b>No. of 90 ELL</b>	1	105	96	53	38	N/A	121	121	114	114	70	
	2	100	91	48	33	N/A	116	116	109	109	65	
	3	95	86	43	28	N/A	111	111	104	104	60	
	4	90	81	38	23	N/A	106	106	99	99	55	
	5	85	76	33	18	N/A	101	101	94	94	50	
	6	80	71	28	13	N/A	96	96	89	89	45	
	7	75	66	23	N/A	N/A	91	91	84	84	40	
	8	70	61	18	N/A	N/A	86	86	79	79	35	
	9	65	56	13	N/A	N/A	81	81	74	74	30	
	10	60	51	N/A	N/A	N/A	76	76	69	69	25	

NOTES - Additional vent pipe and long radius elbows (required) used to terminate vent pipe outside the structure must be included in the total vent length calculation.  
 Intake and exhaust pipes are sized separately.  
 Values in table are for separate intake or exhaust pipe lengths.  
 Both intake and exhaust pipe must be the same size diameter.

**VENT LENGTH EXHAUST USING VENTILATED ATTIC/CRAWLSPACE INTAKE AIR**

**STANDARD TERMINATION AT 0 - 2000 ft. ELEVATION**

Pipe Size		1-1/2 in.						2 in.					2-1/2 in.					3 in.				
Input		030	045	070	090	110	135	030/045	070	090	110	135	030/045	070	090	110	135	030/045	070	090	110	135
No. of 90 ELL	1	20	15	10	N/A	N/A	N/A	71	56	34	14	N/A	100	100	78	43	N/A	118	117	98	98	60
	2	15	10	N/A	N/A	N/A	N/A	66	51	29	9	N/A	95	95	73	38	N/A	113	112	93	93	55
	3	10	N/A	N/A	N/A	N/A	N/A	61	46	24	N/A	N/A	90	90	68	33	N/A	108	107	88	88	50
	4	N/A	N/A	N/A	N/A	N/A	N/A	56	41	19	N/A	N/A	85	85	63	28	N/A	103	102	83	83	45
	5	N/A	N/A	N/A	N/A	N/A	N/A	51	36	14	N/A	N/A	80	80	58	23	N/A	98	97	78	78	40
	6	N/A	N/A	N/A	N/A	N/A	N/A	46	31	9	N/A	N/A	75	75	53	18	N/A	93	92	73	73	35
	7	N/A	N/A	N/A	N/A	N/A	N/A	41	26	N/A	N/A	N/A	70	70	48	13	N/A	88	87	68	68	30
	8	N/A	N/A	N/A	N/A	N/A	N/A	36	21	N/A	N/A	N/A	65	65	43	N/A	N/A	83	82	63	63	25
	9	N/A	N/A	N/A	N/A	N/A	N/A	31	16	N/A	N/A	N/A	60	60	38	N/A	N/A	78	77	58	58	20
	10	N/A	N/A	N/A	N/A	N/A	N/A	26	11	N/A	N/A	N/A	55	55	33	N/A	N/A	73	72	53	53	15

NOTE - Additional vent pipe and long radius elbows (required) used to terminate vent pipe outside the structure must be included in the total vent length calculation.

**STANDARD TERMINATION AT 2001 - 10,000 ft. ELEVATION**

Pipe Size		1-1/2 in.	2 in.									
Input		030	030/045	070				090			110	135
Elevation		---	2001-10,000 ft.	2001-3000 ft.	3001-4000 ft.	4001-10,000 ft.	2001-3000 ft.	3001-4000 ft.	4001-10,000 ft.	2001-10,000 ft.		
No. of 90 ELL	1	N/A	71	50	40	30	25	20	15	N/A	N/A	
	2		66	45	35	25	20	15	10	N/A	N/A	
	3		61	40	30	20	15	10	N/A	N/A	N/A	
	4		56	35	25	15	10	N/A	N/A	N/A	N/A	
	5		51	30	20	10	N/A	N/A	N/A	N/A	N/A	
	6		46	25	15	5	N/A	N/A	N/A	N/A	N/A	
	7		41	20	10	N/A	N/A	N/A	N/A	N/A	N/A	
	8		36	15	5	N/A	N/A	N/A	N/A	N/A	N/A	
	9		31	10	N/A	N/A	N/A	N/A	N/A	N/A	N/A	
	10		26	5	N/A	N/A	N/A	N/A	N/A	N/A	N/A	
Pipe Size		2-1/2 in.					3 in.					
Input		030/045	070	090	110	135	030/045	070	090	110	135	
Elevation		2001-10,000 ft.					2001-10,000 ft.					
No. of 90 ELL	1	100	96	53	38	N/A	118	117	98	98	60	
	2	95	91	48	33	N/A	113	112	93	93	55	
	3	90	86	43	28	N/A	108	107	88	88	50	
	4	85	81	38	23	N/A	103	102	83	83	45	
	5	80	76	33	18	N/A	98	97	78	78	40	
	6	75	71	28	13	N/A	93	92	73	73	35	
	7	70	66	23	N/A	N/A	88	87	68	68	30	
	8	65	61	18	N/A	N/A	83	82	63	63	25	
	9	60	56	13	N/A	N/A	78	77	58	58	20	
	10	55	51	N/A	N/A	N/A	73	72	53	53	15	

NOTE - Additional vent pipe and long radius elbows (required) used to terminate vent pipe outside the structure must be included in the total vent length calculation.

## VENT LENGTHS UNINSULATED EXHAUST PIPE IN UNCONDITIONED SPACE

1 Winter Design Temperatures	Vent Pipe Diameter	Unit Input Size											
		030		045		070		090		110		135	
		2 Maximum Equivalent Uninsulated Exhaust Vent Length (ft.)											
		PVC	3 PolyPro/ InnoFlue/ ECCO	PVC	3 PolyPro/ InnoFlue/ ECCO	PVC	3 PolyPro/ InnoFlue/ ECCO	PVC	3 PolyPro/ InnoFlue/ ECCO	PVC	3 PolyPro/ InnoFlue/ ECCO	PVC	3 PolyPro/ InnoFlue/ ECCO
32 to 21°F	1-1/2 in.	N/A	N/A	25	N/A	25	N/A	N/A	N/A	N/A	N/A	N/A	N/A
	2 in.	N/A	N/A	18	16	31	28	50	48	30	30	N/A	N/A
	2-1/2 in.	N/A	N/A	13	N/A	24	N/A	42	N/A	56	N/A	N/A	N/A
	3 in.	N/A	N/A	9	9	18	18	35	35	47	47	47	47
20 to 1°F	1-1/2 in.	N/A	N/A	15	N/A	20	N/A	N/A	N/A	N/A	N/A	N/A	N/A
	2 in.	N/A	N/A	9	8	18	16	32	29	30	30	N/A	N/A
	2-1/2 in.	N/A	N/A	5	N/A	13	N/A	24	N/A	34	N/A	N/A	N/A
	3 in.	N/A	N/A	N/A	N/A	8	8	19	19	26	26	26	26
0 to -20°F	1-1/2 in.	N/A	N/A	10	N/A	15	N/A	N/A	N/A	N/A	N/A	N/A	N/A
	2 in.	N/A	N/A	5	N/A	12	10	22	19	30	27	N/A	N/A
	2-1/2 in.	N/A	N/A	N/A	N/A	7	N/A	15	N/A	22	N/A	N/A	N/A
	3 in.	N/A	N/A	N/A	N/A	N/A	N/A	10	10	16	16	13	13

<sup>1</sup> Refer to 99% Minimum Design Temperature table provided in the current edition of the ASHRAE Handbook-Fundamentals.

<sup>2</sup> Maximum Equivalent Vent Length permitted is defined as Total Length (linear feet) of vent pipe, plus equivalent length (ft.) of fittings, plus equivalent length (ft.) of termination.

VENTING NOTES - Concentric Terminations are equivalent to 5 ft. of straight pipe and should be included when measuring total pipe length.

One 90° elbow is equivalent to 5 feet of straight vent pipe.

Two 45° elbows are equal to one 90° elbow.

One 45° elbow is equivalent to 2.5 feet of straight vent pipe.

<sup>3</sup> PolyPro® poly-propylene vent pipe is a registered trademark of DuraVent®.

InnoFlue® is a registered trademark of Centrotherm Eco Systems.

ECCO Polypropylene Vent™ is a registered trademark of ECCO Manufacturing™.

# DIMENSIONS

# UNIT - UPFLOW POSITION

- <sup>1</sup> NOTE - 60C and 60D size units that require air volumes over 1800 cfm must have one of the following:
1. Single side return air and Optional Return Air Base with transition that must accommodate required 20 x 25 x 1 inch (508 x 635 x 25 mm) air filter to maintain proper velocity.
  2. Bottom return air.
  3. Return air from both sides.
  4. Bottom and one side return air.
- See Blower Performance Tables for additional information.

<sup>2</sup> Optional Side Return Air Filter Kit is not for use with the Optional Return Air Base.

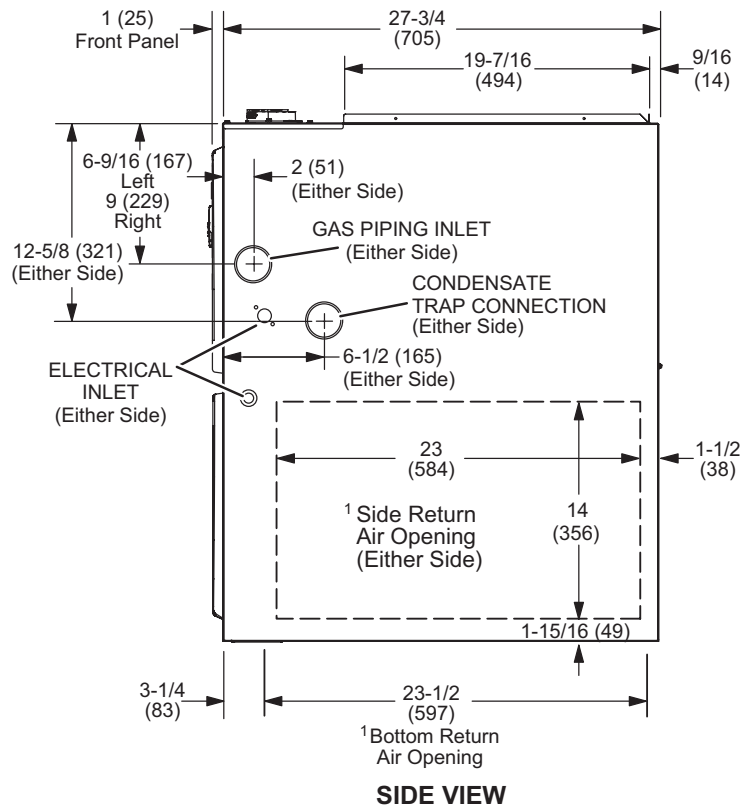
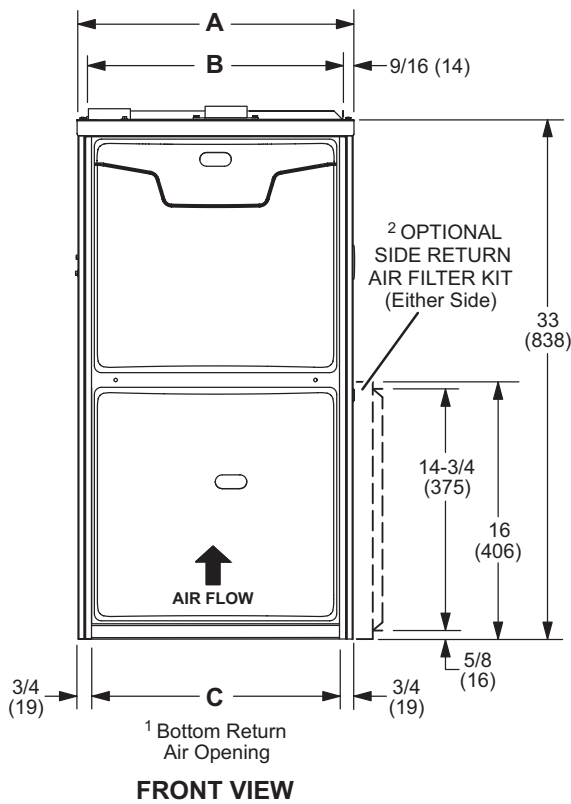
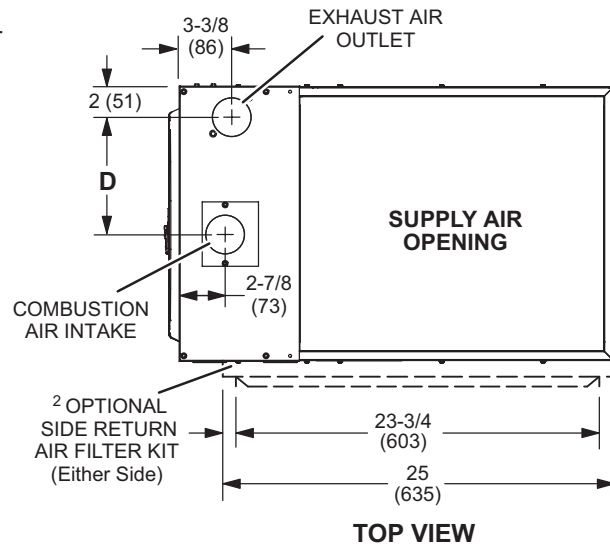
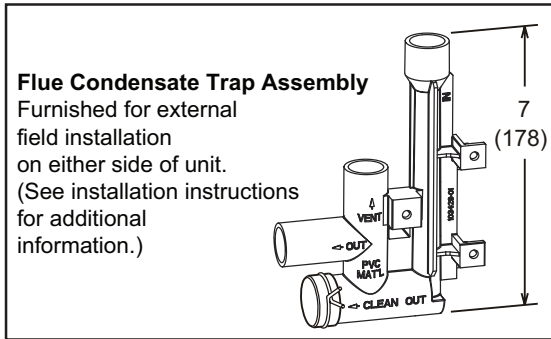

Model No.	A		B		C		D	
	in.	mm	in.	mm	in.	mm	in.	mm
ML196UH030XE36BK ML196UH045XE36BK ML196UH070XE36BK ML196UH070XE48BK	17-1/2	446	16-3/8	416	16	406	7-5/8	194
ML196UH090XE36CK ML196UH090XE48CK ML196UH090XE60CK ML196UH110XE60CK	21	533	19-7/8	505	19-1/2	495	9-3/8	238
ML196UH135XE60DK	24-1/2	622	23-3/8	594	23	584	11-1/8	283

**LEFT-HAND AIR DISCHARGE**

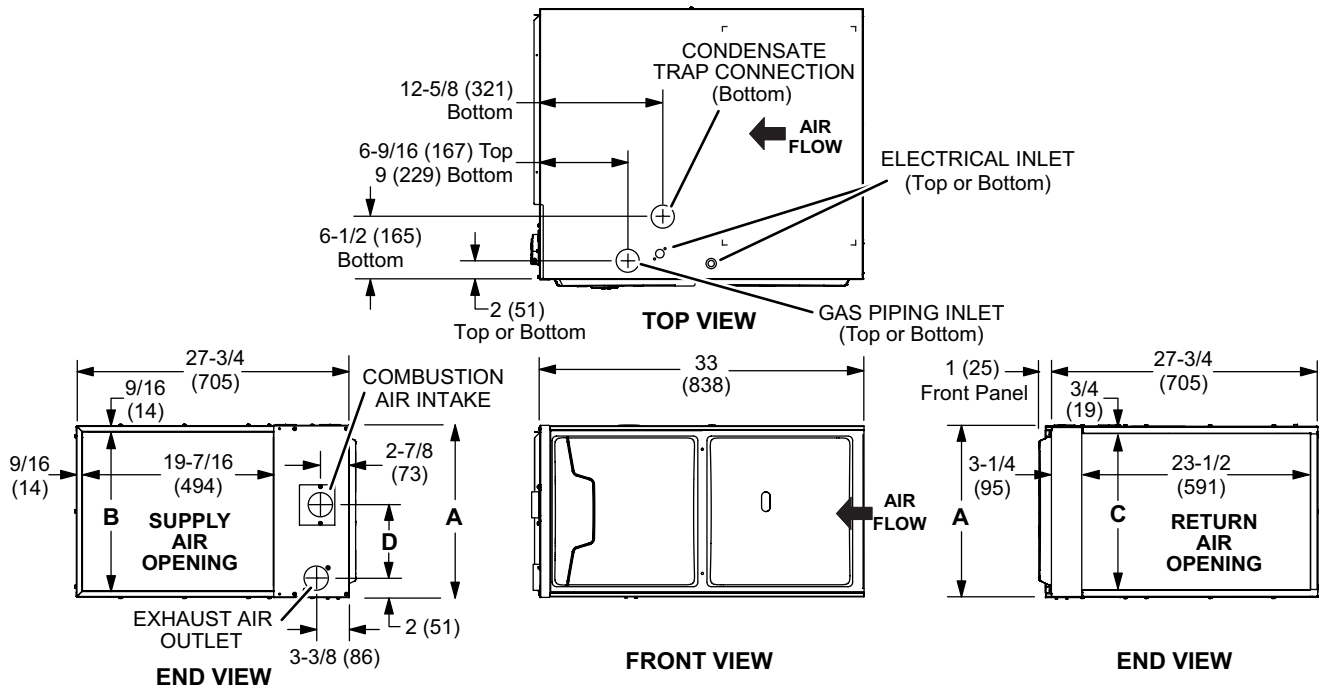

**RIGHT-HAND AIR DISCHARGE**

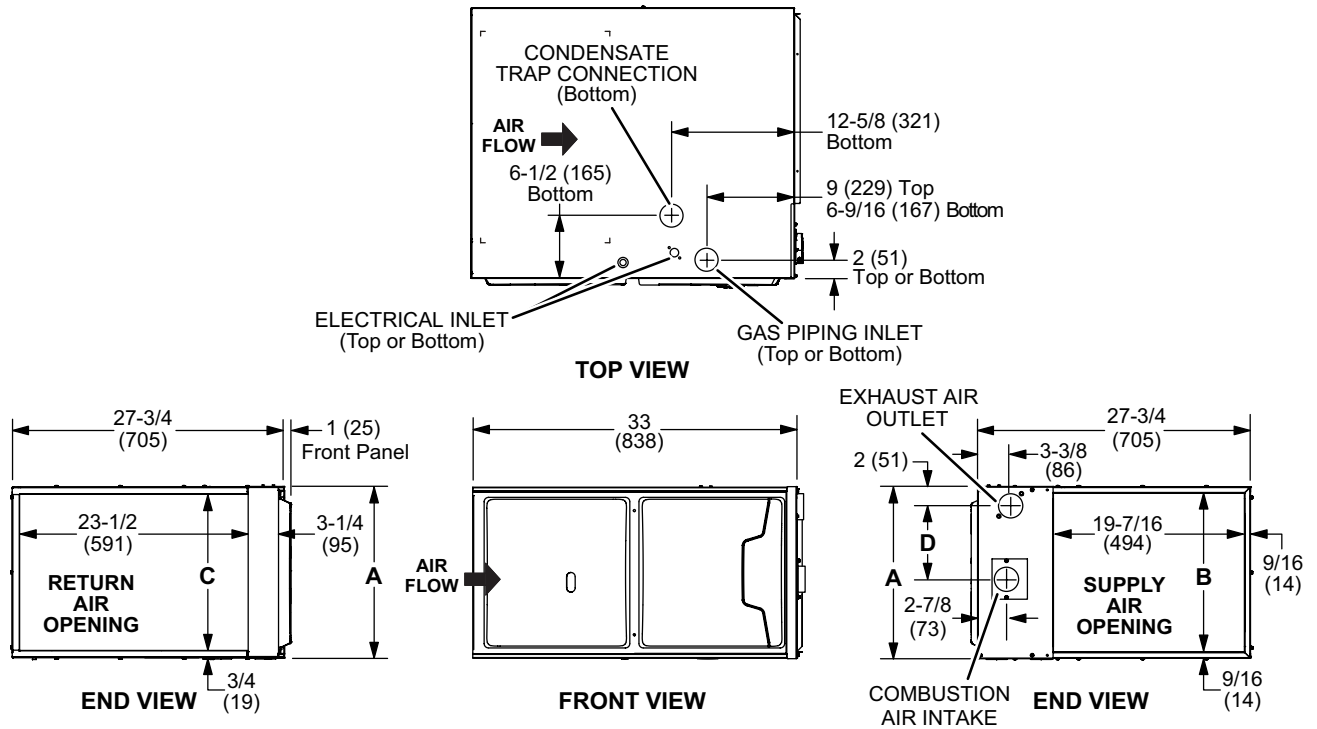

Model No.	A		B		C		D	
	in.	mm	in.	mm	in.	mm	in.	mm
ML196UH030XE36BK ML196UH045XE36BK ML196UH070XE36BK ML196UH070XE48BK	17-1/2	446	16-3/8	416	16	406	7-5/8	194
ML196UH090XE36CK ML196UH090XE48CK ML196UH090XE60CK ML196UH110XE60CK	21	533	19-7/8	505	19-1/2	495	9-3/8	238
ML196UH135XE60DK	24-1/2	622	23-3/8	594	23	584	11-1/8	283

**HORIZONTAL (END) FILTER KIT**

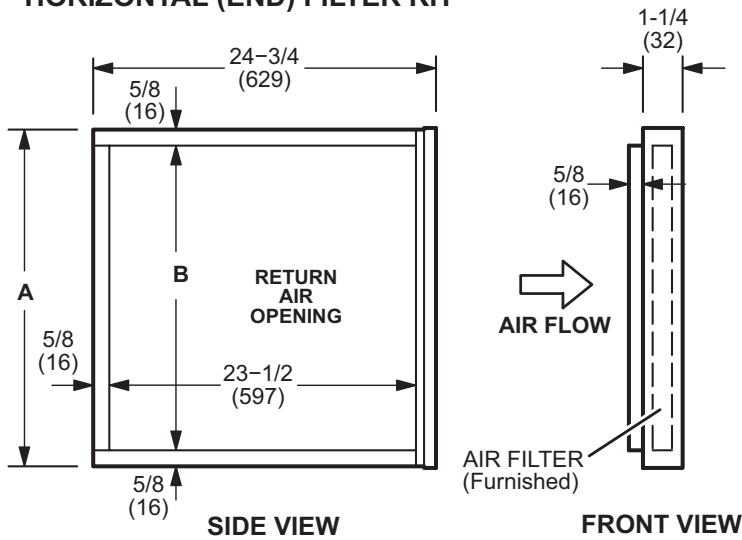

Furnace Cabinet Width	Catalog Number	A		B	
		in.	mm	in.	mm
B	87L96	18	457	16-3/4	425
C	87L97	21	533	18-3/4	476
D	87L98	25	635	23-3/4	603

**Optional Return Air Base  
(Upflow Applications Only - For use with B, C and D cabinets)**

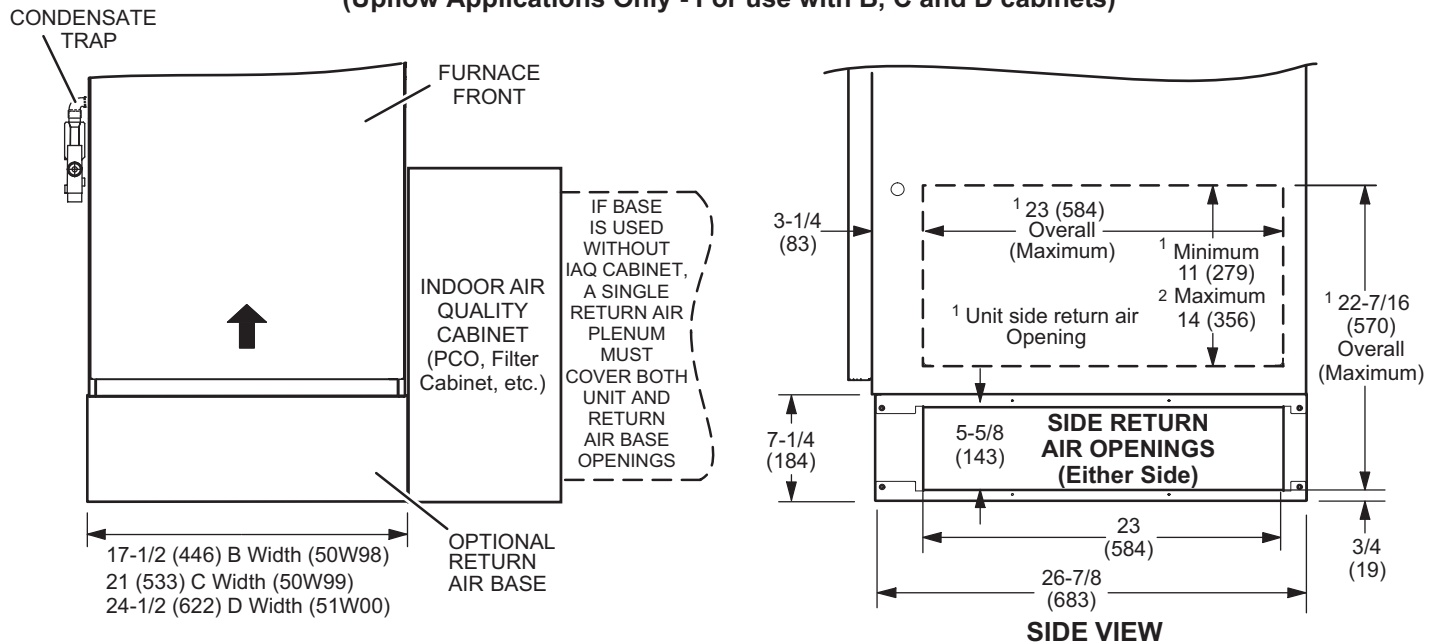

**NOTE-** Optional Side Return Air Filter Kits are not for use with Optional Return Air Base.

- <sup>1</sup> Both the unit return air opening and the base return air opening must be covered by a single plenum or IAQ cabinet. Minimum unit side return air opening dimensions for units requiring 1800 cfm or more of air (W x H): 23 x 11 in. (584 x 279 mm). The opening can be cut as needed to accommodate plenum or IAQ cabinet while maintaining dimensions shown. Side return air openings must be cut in the field. There are cutting guides stenciled on the cabinet for the side return air opening. The size of the opening must not extend beyond the markings on the furnace cabinet.
- <sup>2</sup> To minimize pressure drop, the largest opening height possible, up to 14 in. (356 mm), is preferred.

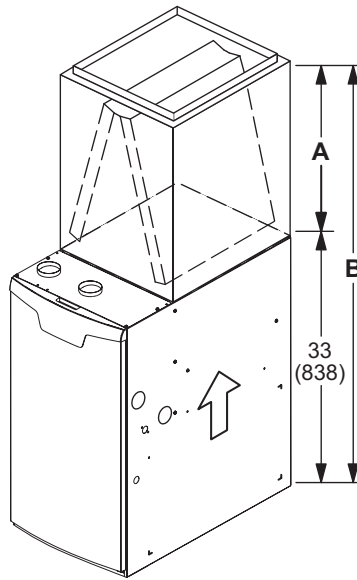

**UPFLOW POSITION - CASED**

Model	A		B	
	in.	mm	in.	mm
<b>CK40CT</b>				
CK40CT-18/24B	16-1/2	419	49-1/2	1257
CK40CT-24B	18-1/2	470	51-1/2	1308
CK40CT-30B	22-1/2	572	55-1/2	1410
CK40CT-30/36B CK40CT-30/36C	24-1/2	622	57-1/2	1461
CK40CT-36B CK40CT-36C	24-1/2	622	57-1/2	1461
CK40CT-48B CK40CT-48C	27-1/2	699	60-1/2	1537
CK40CT-49C	29-1/2	749	62-1/2	1588
CK40CT-50/60C	27-1/2	699	60-1/2	1537
CK40CT-60C	31-1/2	800	64-1/2	1638
CK40CT-60D	29-1/2	749	62-1/2	1588

**UPFLOW POSITION - UNCASD**

Model	A		B	
	in.	mm	in.	mm
<b>CK40UT</b>				
CK40UT-18/24B	14-1/8	359	47-1/8	1197
CK40UT-24B	16-3/8	416	49-3/8	1254
CK40UT-30B	20-3/4	527	53-3/4	1365
CK40UT-30/36B CK40UT-30/36C CK40UT-36C	22-1/4	565	55-1/4	1403
CK40UT-36B	22-3/8	568	55-3/8	1407
CK40UT-48B CK40UT-48C	26-1/4	667	59-1/4	1505
CK40UT-49C	28-1/2	724	61-1/2	1562
CK40UT-50/60C	25-7/8	657	58-7/8	1495
CK40UT-60C	30-5/8	778	63-5/8	1616
CK40UT-60D	28	711	61	1549

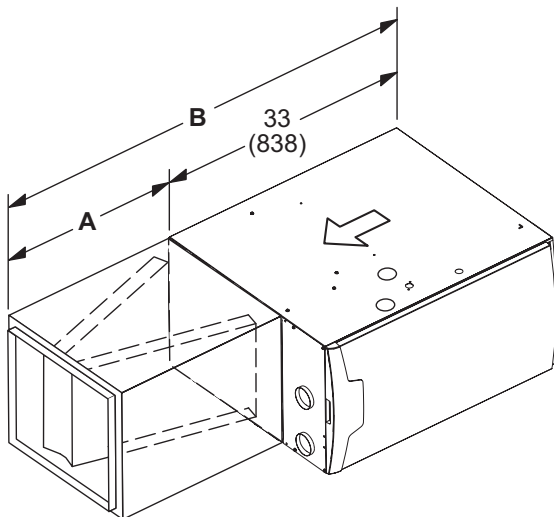

**HORIZONTAL POSITION**

Model	A		B	
	in.	mm	in.	mm
<b>CK40HT</b>				
CK40HT-24B CK40HT-30B CK40HT-36A CK40HT-36B CK40HT-36C CK40HT-42C CK40HT-48C	26-1/2	673	59-1/2	1511
CK40CT-42B CK40CT-48B CK40CT-51/61C CK40CT-60D	31-1/2	880	64-1/2	1638

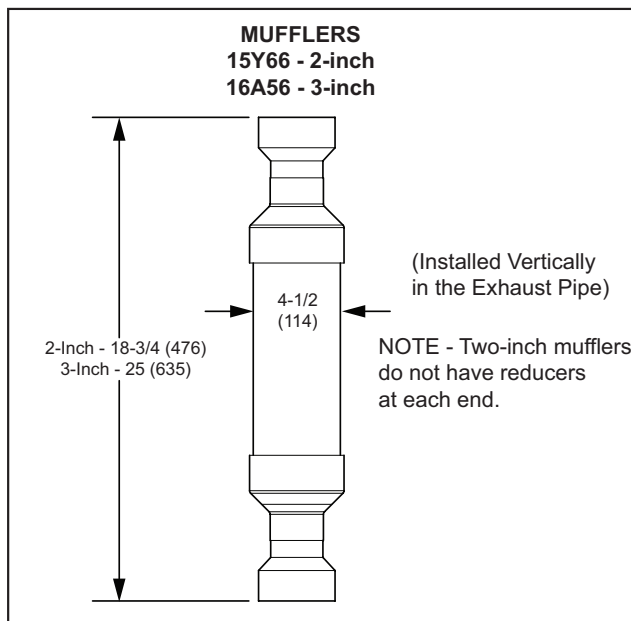
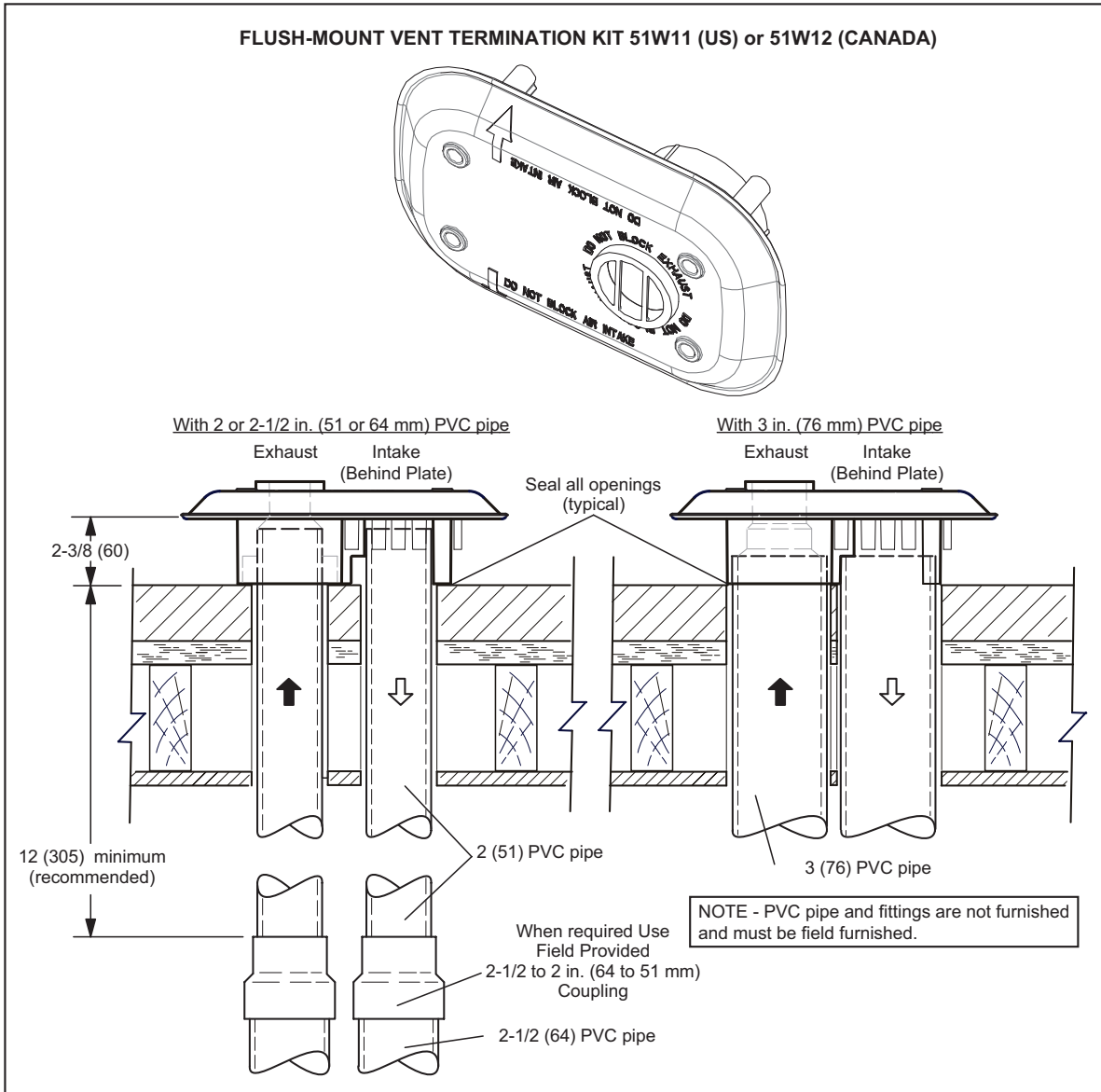

**CONCENTRIC WALL  
TERMINATION APPLICATIONS**

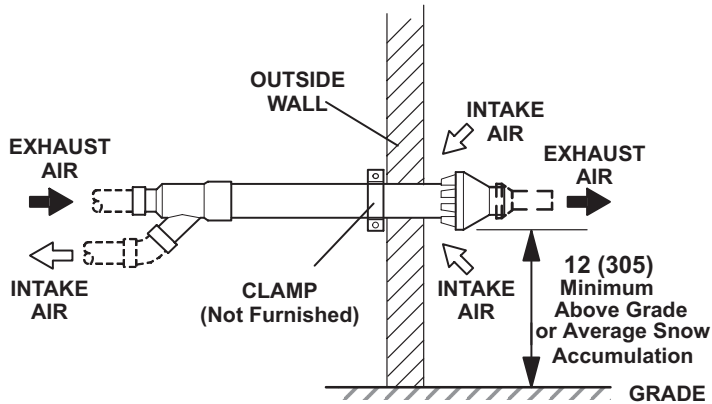

**CONCENTRIC ROOF  
TERMINATION APPLICATIONS**

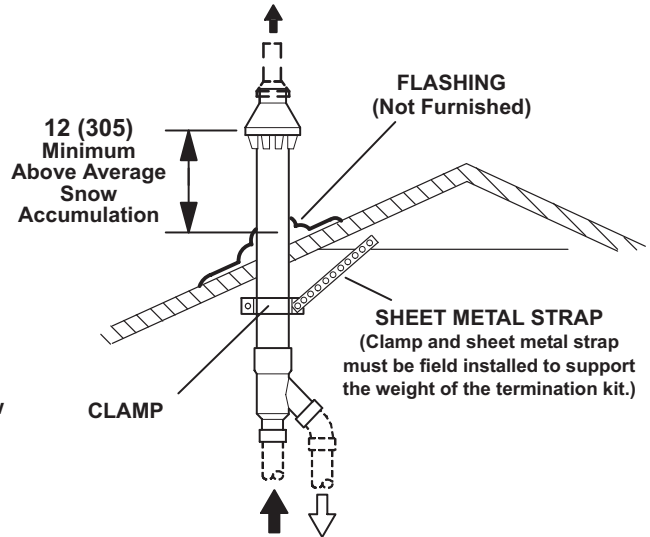

**71M80 / 69M29 / 44W92 – 2 inch kits**

**60L46 / 44W93 – 3 inch kits**

**See Installation Instructions for additional information.**

Note - Field provided reducer may be required to adapt different vent pipe sizes to termination.

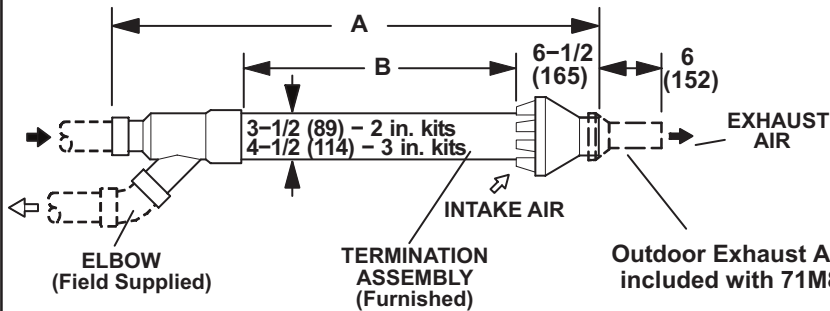

Cat. No.	A		B	
	in.	mm	in.	mm
71M80 69M29	33-3/8	848	16-3/4	425
44W92 (Canada)	29	737	15-1/2	394
60L46	38-7/8	987	21-3/16	538
44W93 (Canada)	36-1/8	918	19-1/2	495

**NOTE – Typical illustration for dimensions only. Design may vary depending on kit ordered.**

**WALL TERMINATION KITS (CLOSE-COUPLE)  
EXTENDED VENT FOR GRADE CLEARANCE  
2 inch (51 mm) 22G44 (US)  
3 inch (76 mm) 44J40 (US)**

**See Installation Instructions for additional information.**

Note - Field provided reducer may be required to adapt different vent pipe sizes to termination.

If Intake and Exhaust Pipe is less than 12 in. (305 mm) above snow accumulation or other obstructions, field fabricated piping must be installed.

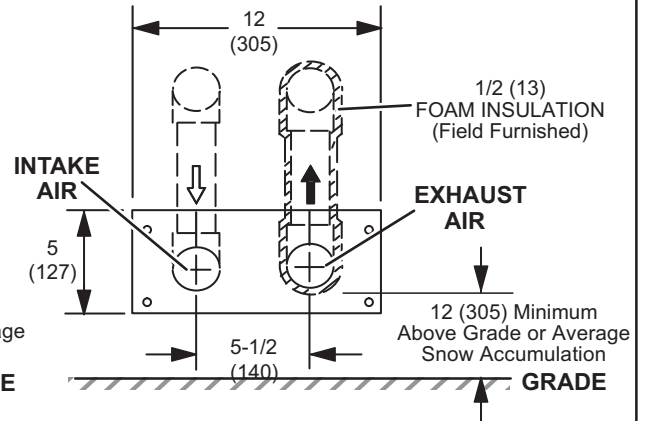
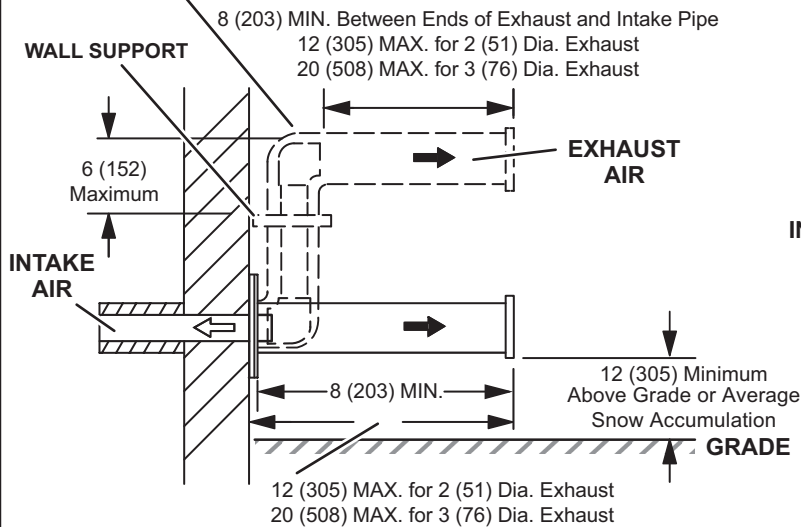

**WALL TERMINATION KITS (CLOSE-COUPLE)  
EXTENDED VENT FOR GRADE CLEARANCE  
2 inch (51 mm) 30G28 (WTK Canada)  
3 inch (76 mm) 81J20 (WTK Canada)**

**See Installation Instructions for additional information.**

Note - Field provided reducer may be required to adapt different vent pipe sizes to termination.

If Intake and Exhaust Pipe is less than 12 in. (305 mm) above snow accumulation or other obstructions, field fabricated piping must be installed.

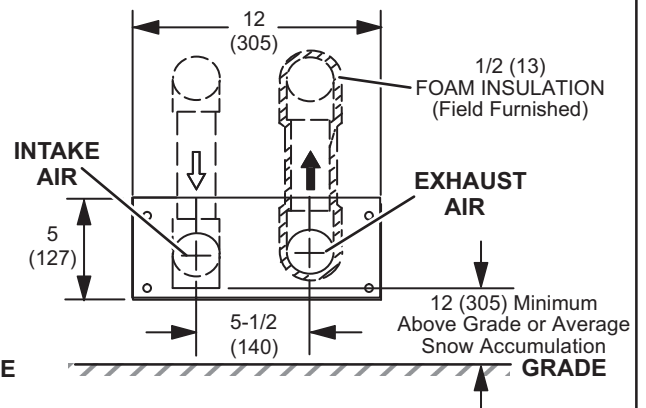
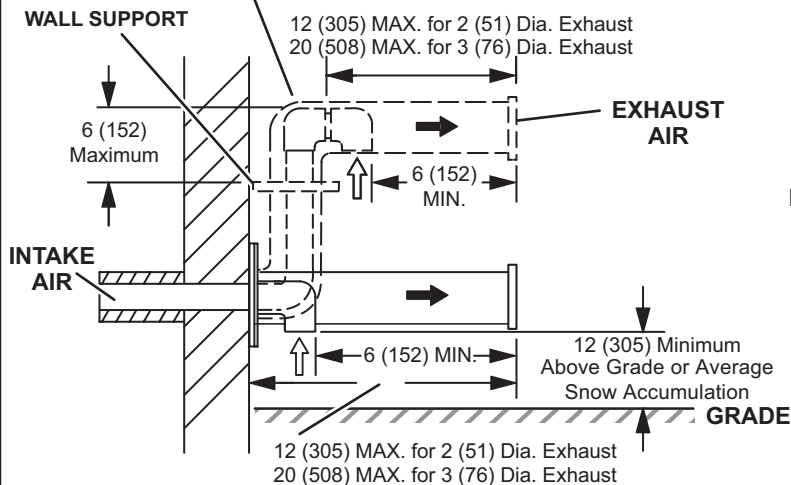

## BLOWER DATA

### ML196UH030XE36BK PERFORMANCE (Less Filter)

External Static Pressure in. w.g.	Air Volume / Watts at Various Blower Speeds									
	High (Black)		Medium-High (Brown)		Medium (Blue)		Medium-Low (Yellow)		Low (Red)	
	cfm	Watts	cfm	Watts	cfm	Watts	cfm	Watts	cfm	Watts
0.10	1374	346	1109	198	940	130	743	75	725	75
0.20	1346	360	1080	206	902	138	684	82	546	56
0.30	1321	370	1047	217	866	149	633	90	465	60
0.40	1295	384	1012	228	834	155	589	96	408	67
0.50	1265	395	985	235	794	165	540	107	351	72
0.60	1224	396	956	247	760	175	500	110	306	79
0.70	1152	379	929	256	730	180	453	120	266	84
0.80	1088	353	894	267	673	192	413	125	224	89
0.90	914	304	855	273	644	200	374	132	---	---
1.00	755	262	694	243	607	208	---	---	---	---

### ML196UH045XE36BK PERFORMANCE (Less Filter)

External Static Pressure in. w.g.	Air Volume / Watts at Various Blower Speeds									
	High (Black)		Medium-High (Brown)		Medium (Blue)		Medium-Low (Yellow)		Low (Red)	
	cfm	Watts	cfm	Watts	cfm	Watts	cfm	Watts	cfm	Watts
0.10	1329	310	1191	233	1084	184	887	116	844	105
0.20	1298	320	1160	242	1050	192	846	122	801	111
0.30	1270	328	1129	251	1015	199	804	128	759	117
0.40	1239	337	1098	259	979	206	762	134	717	123
0.50	1209	346	1065	266	943	213	721	140	674	130
0.60	1181	355	1032	274	910	221	678	147	629	136
0.70	1154	364	1001	283	876	228	636	153	587	141
0.80	1124	373	971	292	841	236	598	159	547	147
0.90	1096	382	939	300	805	244	559	165	498	154
1.00	1069	392	907	308	769	251	510	172	444	159

### ML196UH070XE36BK PERFORMANCE (Less Filter)

External Static Pressure in. w.g.	Air Volume / Watts at Various Blower Speeds									
	High (Black)		Medium-High (Brown)		Medium (Blue)		Medium-Low (Yellow)		Low (Red)	
	cfm	Watts	cfm	Watts	cfm	Watts	cfm	Watts	cfm	Watts
0.10	1388	292	1244	221	1131	173	925	110	884	100
0.20	1359	302	1212	230	1096	182	886	116	843	107
0.30	1331	313	1182	238	1062	190	846	123	802	114
0.40	1301	323	1151	247	1028	198	805	130	759	120
0.50	1273	333	1121	256	996	206	764	137	717	127
0.60	1245	342	1090	265	961	215	720	145	670	134
0.70	1217	352	1059	274	928	223	671	151	616	140
0.80	1187	362	1026	283	892	231	623	157	566	146
0.90	1158	371	995	292	854	240	578	163	519	151
1.00	1128	381	962	302	814	248	532	169	464	156

## BLOWER DATA

### ML196UH070XE48BK PERFORMANCE (Less Filter)

External Static Pressure in. w.g.	Air Volume / Watts at Various Blower Speeds									
	High (Black)		Medium-High (Brown)		Medium (Blue)		Medium-Low (Yellow)		Low (Red)	
	cfm	Watts	cfm	Watts	cfm	Watts	cfm	Watts	cfm	Watts
0.10	1876	637	1708	480	1489	329	1320	234	1227	189
0.20	1845	652	1665	492	1452	344	1275	243	1175	199
0.30	1810	665	1640	508	1414	357	1245	254	1130	210
0.40	1755	663	1601	520	1381	369	1186	268	1078	220
0.50	1691	651	1570	536	1336	381	1154	280	1031	232
0.60	1632	631	1528	550	1292	394	1106	290	979	246
0.70	1537	600	1490	555	1249	408	1059	303	928	252
0.80	1433	567	1400	537	1216	421	1011	313	890	263
0.90	1321	527	1296	511	1169	433	969	325	833	273
1.00	1204	493	1184	481	1118	435	919	336	781	283

### ML196UH090XE36CK PERFORMANCE (Less Filter)

External Static Pressure in. w.g.	Air Volume / Watts at Various Blower Speeds									
	High (Black)		Medium-High (Brown)		Medium (Blue)		Medium-Low (Yellow)		Low (Red)	
	cfm	Watts	cfm	Watts	cfm	Watts	cfm	Watts	cfm	Watts
0.10	1478	345	1343	265	1181	186	920	99	824	79
0.20	1448	356	1310	278	1152	197	892	109	709	72
0.30	1418	369	1282	288	1123	210	847	115	661	76
0.40	1353	380	1256	299	1095	219	812	125	627	85
0.50	1362	392	1233	311	1064	227	782	131	575	91
0.60	1340	403	1203	317	1040	237	744	140	540	99
0.70	1308	413	1180	327	1004	244	717	150	487	103
0.80	1266	412	1151	336	969	255	668	156	444	113
0.90	1202	393	1116	345	948	264	639	165	406	116
1.00	1087	354	1058	341	911	270	581	170	361	124

### ML196UH090XE48CK PERFORMANCE (Less Filter)

External Static Pressure in. w.g.	Air Volume / Watts at Various Blower Speeds									
	High (Black)		Medium-High (Brown)		Medium (Blue)		Medium-Low (Yellow)		Low (Red)	
	cfm	Watts	cfm	Watts	cfm	Watts	cfm	Watts	cfm	Watts
0.10	1700	387	1489	274	1371	222	1289	193	1170	152
0.20	1664	400	1452	285	1331	233	1245	202	1123	161
0.30	1629	412	1413	296	1289	243	1202	211	1078	170
0.40	1596	424	1374	307	1248	252	1160	220	1031	178
0.50	1561	436	1337	317	1209	262	1117	229	987	186
0.60	1528	448	1300	328	1168	272	1073	237	933	194
0.70	1494	459	1261	338	1126	281	1029	246	885	201
0.80	1459	470	1221	347	1083	290	989	255	842	209
0.90	1425	482	1181	358	1042	299	949	264	798	217
1.00	1388	493	1142	368	1004	308	908	273	748	225

## BLOWER DATA

### ML196UH090XE60CK PERFORMANCE (Less Filter)

External Static Pressure in. w.g.	Air Volume / Watts at Various Blower Speeds									
	High (Black)		Medium-High (Brown)		Medium (Blue)		Medium-Low (Yellow)		Low (Red)	
	cfm	Watts	cfm	Watts	cfm	Watts	cfm	Watts	cfm	Watts
0.10	2067	631	1820	430	1663	333	1566	276	1390	206
0.20	2027	644	1791	444	1627	345	1524	291	1347	216
0.30	1992	660	1741	460	1583	355	1485	302	1306	223
0.40	1965	673	1703	473	1546	369	1439	313	1254	235
0.50	1938	691	1681	483	1503	383	1395	326	1210	245
0.60	1901	706	1635	500	1462	395	1359	337	1158	257
0.70	1871	719	1607	512	1428	405	1315	349	1112	264
0.80	1815	708	1559	527	1387	417	1273	358	1071	275
0.90	1711	679	1536	538	1349	429	1229	371	1018	285
1.00	1629	649	1485	551	1309	441	1188	380	963	293

## BLOWER DATA

### ML196UH110XE60CK PERFORMANCE (Less Filter)

External Static Pressure in. w.g.	Air Volume / Watts at Different Blower Speeds																			
	Bottom Return Air, Side Return Air with Return Air from Both Sides or Return Air from Bottom and One Side.										Single Side Return Air – Air volumes in <b>bold</b> (over 1800 cfm) require Optional Return Air Base and field fabricated transition to accommodate 20 x 25 x 1 in. air filter in order to maintain proper air velocity.									
	High (Black)		Medium-High (Brown)		Medium (Blue)		Medium-Low (Yellow)		Low (Red)		High (Black)		Medium-High (Brown)		Medium (Blue)		Medium-Low (Yellow)		Low (Red)	
	cfm	Watts	cfm	Watts	cfm	Watts	cfm	Watts	cfm	Watts	cfm	Watts	cfm	Watts	cfm	Watts	cfm	Watts	cfm	Watts
0.10	2159	658	1905	464	1744	364	1631	306	1451	227	<b>2093</b>	<b>644</b>	<b>1858</b>	<b>438</b>	1688	341	1590	281	1410	205
0.20	2122	674	1865	476	1701	376	1585	319	1403	240	<b>2064</b>	<b>655</b>	<b>1824</b>	<b>451</b>	1653	349	1546	296	1367	216
0.30	2087	689	1828	492	1657	389	1542	331	1360	252	<b>2033</b>	<b>669</b>	1788	467	1619	363	1511	306	1321	228
0.40	2051	705	1793	507	1616	402	1497	342	1310	262	<b>1996</b>	<b>686</b>	1749	482	1580	376	1473	322	1275	239
0.50	2016	721	1754	521	1574	415	1456	354	1260	271	<b>1971</b>	<b>704</b>	1709	498	1543	392	1436	330	1230	251
0.60	1982	736	1714	534	1534	426	1411	366	1213	282	<b>1941</b>	<b>720</b>	1676	512	1503	403	1387	347	1184	262
0.70	1947	751	1676	547	1494	439	1370	377	1167	291	<b>1903</b>	<b>734</b>	1644	524	1468	419	1351	356	1140	271
0.80	1913	767	1637	560	1454	450	1331	390	1118	302	<b>1855</b>	<b>732</b>	1606	542	1424	430	1313	369	1105	282
0.90	1876	782	1600	573	1415	462	1291	402	1066	312	1780	707	1571	554	1386	443	1273	380	1061	293
1.00	1841	795	1564	588	1376	474	1248	414	1012	321	1675	670	1535	569	1352	456	1238	392	1019	302

### ML196UH135XE60DK PERFORMANCE (Less Filter)

External Static Pressure in. w.g.	Air Volume / Watts at Different Blower Speeds																			
	Bottom Return Air, Side Return Air with Return Air from Both Sides or Return Air from Bottom and One Side.										Single Side Return Air – Air volumes in <b>bold</b> (over 1800 cfm) require Optional Return Air Base and field fabricated transition to accommodate 20 x 25 x 1 in. air filter in order to maintain proper air velocity.									
	High (Black)		Medium-High (Brown)		Medium (Blue)		Medium-Low (Yellow)		Low (Red)		High (Black)		Medium-High (Brown)		Medium (Blue)		Medium-Low (Yellow)		Low (Red)	
	cfm	Watts	cfm	Watts	cfm	Watts	cfm	Watts	cfm	Watts	cfm	Watts	cfm	Watts	cfm	Watts	cfm	Watts	cfm	Watts
0.10	2383	865	2200	687	2016	534	1791	385	1597	285	<b>2340</b>	<b>883</b>	<b>2167</b>	<b>694</b>	<b>1995</b>	<b>534</b>	1780	392	1611	291
0.20	2349	884	2165	703	1979	549	1750	400	1553	298	<b>2303</b>	<b>901</b>	<b>2125</b>	<b>715</b>	<b>1956</b>	<b>551</b>	1752	402	1560	306
0.30	2314	902	2130	720	1939	564	1709	413	1512	313	<b>2277</b>	<b>912</b>	<b>2095</b>	<b>733</b>	<b>1920</b>	<b>566</b>	1711	417	1527	316
0.40	2280	921	2096	739	1906	581	1668	427	1469	325	<b>2253</b>	<b>933</b>	<b>2067</b>	<b>748</b>	<b>1882</b>	<b>581</b>	1670	433	1479	329
0.50	2246	936	2060	754	1866	592	1629	441	1426	337	<b>2215</b>	<b>951</b>	<b>2037</b>	<b>762</b>	<b>1850</b>	<b>595</b>	1634	444	1444	342
0.60	2214	953	2028	771	1831	607	1586	453	1385	349	<b>2188</b>	<b>967</b>	<b>2007</b>	<b>781</b>	<b>1816</b>	<b>608</b>	1601	460	1404	355
0.70	2185	971	1996	786	1798	622	1544	465	1342	362	<b>2159</b>	<b>989</b>	<b>1973</b>	<b>797</b>	1779	627	1565	474	1363	368
0.80	2151	985	1960	802	1753	634	1506	478	1304	374	<b>2127</b>	<b>1004</b>	<b>1938</b>	<b>815</b>	1742	638	1525	487	1315	380
0.90	2098	983	1928	819	1722	650	1468	492	1260	384	<b>2096</b>	<b>1023</b>	<b>1906</b>	<b>828</b>	1716	655	1487	501	1276	390
1.00	2044	979	1898	836	1685	663	1430	504	1220	396	<b>1997</b>	<b>936</b>	<b>1870</b>	<b>840</b>	1670	670	1441	513	1237	399

## REVISIONS

Sections	Description of Change
Approvals	Updated ENERGY STAR® usage.
Control Options	Updated to reflect latest product offering.
Dimensions	Updated Furnace/Coil Combined Dimensions to add latest product offering.



Visit us at [www.Lennox.com](http://www.Lennox.com)

For the latest technical information, [www.LennoxPros.com](http://www.LennoxPros.com)

Contact us at 1-800-9-LENNOX

NOTE - Due to Lennox' ongoing commitment to quality, Specifications, Ratings and Dimensions subject to change without notice and without incurring liability. Improper installation, adjustment, alteration, service or maintenance can cause property damage or personal injury. Installation and service must be performed by a qualified installer and servicing agency.

©2026 Lennox Industries, Inc.