



ELKC

ELITE® SERIES

Split Systems | **R-454B** | 60Hz

COMMERCIAL PRODUCT SPECIFICATIONS (EHB)

IEER up to 15.0

6 to 20 Tons

Cooling Capacity - 69,000 to 232,000 Btuh



072-090 Models



120-150 Models



180-240 Models



ELITE® SERIES

MODEL NUMBER IDENTIFICATION

EL 120 K C S D T 1 Y

Product Tier
EL = Elite® Series

Nominal Cooling Capacity - Tons
072 = 6 Tons
090 = 7.5 Tons
120 = 10 Tons
150 = 12.5 Tons
180 = 15 Tons
240 = 20 Tons

Refrigerant Type
K = R-454B

Unit Type
C = Split System Air Conditioner

Voltage
Y = 208/230V-3 phase-60Hz
G = 460V-3 phase-60Hz
J = 575V-3 phase-60Hz

Minor Design Sequence
1 = 1st Revision

Part Load Capability
T = Two-Stage Compressor

Refrigerant Circuits
S = Single Circuit
D = Dual Circuits

Cooling Efficiency
S = Standard Efficiency

FEATURE HIGHLIGHTS

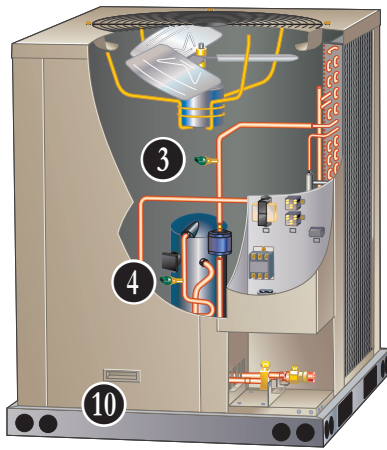

072-090 Models

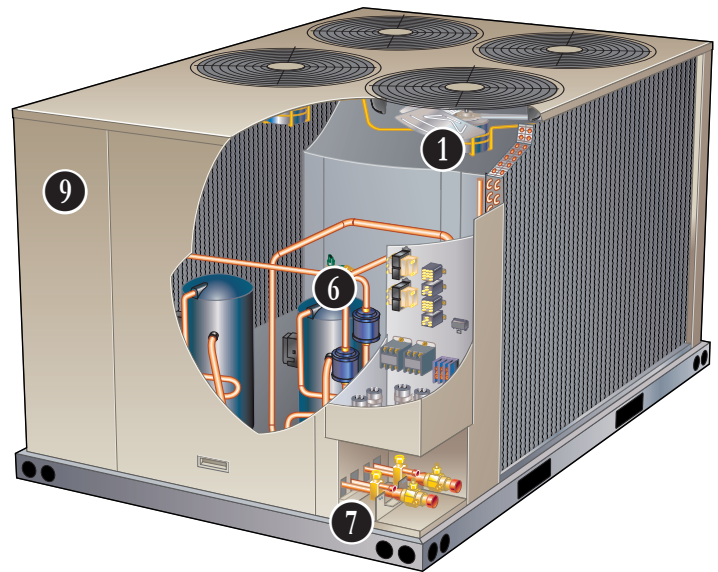

180-240 Models

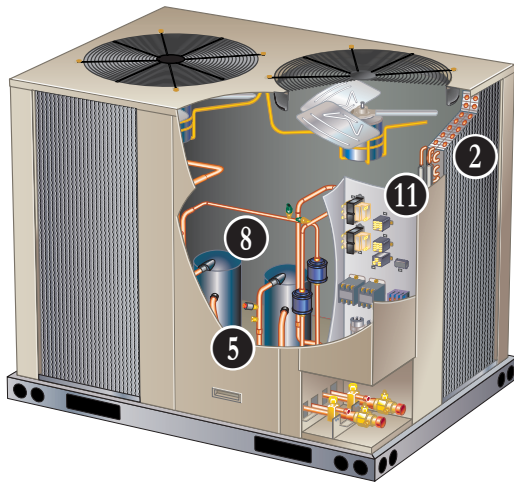

120 Model (150 Model Similar)

1. Outdoor Coil Fans
2. Copper Tube/Enhanced Fin Coils
3. High Pressure Switch
4. Low Pressure Switch
5. Loss of Charge Switch
6. Hi-Capacity Driers
7. Refrigerant Lines and Service Valves
8. Scroll Compressors
9. Heavy Gauge Pre-Painted Steel Cabinet
10. Heavy Duty Steel Base Rails
11. Control Box

CONTENTS

| | |
|---|----|
| AHRI System Matches | 14 |
| Approvals And Warranty | 3 |
| Dimensions | 16 |
| - EL072KCSST EL090KCSST | 16 |
| - EL120KCSST EL120KCSDT EL150KCSDT | 17 |
| - EL180KCSDT EL240KCSDT | 18 |
| Electrical Data | 9 |
| Features And Benefits | 3 |
| Model Number Identification. | 1 |
| Optional Conventional Temperature Control Systems | 7 |
| Options / Accessories | 13 |
| Ratings | 19 |
| Sequence Of Operation. | 6 |
| Sound Data | 13 |
| Specifications | 9 |
| Unit Clearances | 15 |
| Weight Data | 12 |

APPROVALS AND WARRANTY

APPROVALS

- All models are AHRI Standard 340/360-2022 certified
- ETL listed
- All models are ASHRAE 90.1-2025 compliant
- All models meet DOE 2023 energy efficiency standards
- Components are bonded for grounding to meet safety standards for servicing required by ETL, NEC and CEC
- All models have been sound tested in accordance with test conditions included in AHRI Standard 270 or 370
- ISO 9001 Registered Manufacturing Quality System
- All models are fully charged and run tested to verify unit operation and functionality

WARRANTY

- Compressors - Limited five years in non-residential applications
- All other covered components - Limited one year

FEATURES AND BENEFITS

APPLICATIONS

- One Compressor - 6, 7.5, 10 ton models
- Two Compressors - 10, 12.5, 15 and 20 ton models
- Applicable to matching indoor air handlers and indoor add-on coils
- Shipped completely factory assembled, piped, and wired
- Test operated at the factory insuring proper operation

REFRIGERATION SYSTEM

R-454B Refrigerant

- Low GWP (Global Warming Potential)
- Zero ODP (Ozone Depletion Potential)
- Low Toxicity/Lower Flammability - A2L

NOTE - Refrigerant is not furnished and must be field supplied.

NOTE - Total system refrigerant charge is dependent on outdoor unit size, indoor unit size and refrigerant line length.

NOTE - Refer to the unit-mounted charging sticker to determine correct amount of charge required.

1 Outdoor Coil Fans

- One Outdoor Fan - 072 and 090
- Two Outdoor Fans - 120 and 150
- Four Outdoor Fans - 180 and 240
- Direct drive fans moves large volumes of air uniformly through entire condenser coil for high refrigerant cooling capacity
- Totally enclosed fan motors
- Overload protected
- Rain shield furnished

2 Copper Tube/Enhanced Fin Coils

- Wrap-around "U" Shaped Coil - 072-090-120 models
- Two "L" Shaped Coils - 150-180-240 models
- Lennox designed and fabricated coils
- Ripple-edge aluminum fins
- Seamless copper tube construction

- Lanced fins for maximum fin surface exposure
- Fin collars grip tubing for maximum contact area
- Flared shoulder tubing connections
- Machine brazed silver soldering
- Factory tested under high pressure
- Completely accessible for cleaning

3 High Pressure Switches

- Protects the system from high pressure conditions
- Manual reset

4 Low Pressure Switches

- EL072KCSST, EL090KCSST, EL120KCSST single circuit models
- Shuts off unit if suction pressure falls below setting
- Loss of charge and freeze-up protection
- Automatic reset

5 Loss of Charge Switches

- EL120KCSDT, EL150KCSDT, EL180KCSDT, EL240KCSDT dual circuit models
- Shuts off unit if liquid line pressure falls below setting
- Provides loss of charge and freeze-up protection
- Automatic reset

6 Hi-Capacity Driers

- Traps moisture or dirt

7 Refrigerant Lines and Service Valves

- Suction and liquid lines located on corner of unit
- Sweat connections
- See dimension drawings
- Fully serviceable suction and liquid line service valves provide complete service access to refrigerant system
- Suction valve can be fully shut off, while liquid valve can be front sealed to manage refrigerant charge while servicing system
- Accessible outside of unit cabinet

FEATURES AND BENEFITS

LOW GWP REFRIGERANT DETECTION SYSTEM (RDS)

- Complies with UL 60335-2-40 approved standard
- Required for all systems using R-454B refrigerant
- Factory installed on all indoor units
- Consists of a leak detection sensor(s) and a mitigation control
- Ensures safe operation for systems equipped with R-454B refrigerant
- Sensor(s) monitors indoor coil area for R-454B refrigerant
- If R-454B refrigerant is detected, the refrigerant detection system will stop compressor and/or heating operation and operate the blower to reduce concentrations in the conditioned space
- Once safe levels are reached the HVAC system will resume normal operation
- Refrigeration detection system energizes blower if R-454B refrigerant is detected to mitigate any concentrations of refrigerant from the unit and the system

SCROLL COMPRESSORS

- 8 Single Two-Stage Compressor - EL072KCSST, EL090KCSST and EL120KCSST single circuit models
- Dual Two-Stage Compressors - EL120KCSDT, EL150KCSDT, EL180KCSDT and EL240KCSDT dual-circuit models
- High efficiency with uniform suction flow
- Constant discharge flow, high volumetric efficiency and quiet operation
- Low gas pulses during compression reduces operational sound levels
- Compressor motor is internally protected from excessive current and temperature
- Compressor is installed in the unit on resilient rubber mounts for vibration free operation

Scroll Compressor Operation

- Two involute spiral scrolls matched together generate a series of crescent-shaped gas pockets between them
- During compression, one scroll remains stationary while the other scroll orbits around it
- Gas is drawn into the outer pocket, the pocket is sealed as the scroll rotates
- As the spiral movement continues, gas pockets are pushed to the center of the scrolls
- Volume between the pockets is simultaneously reduced
- When the pocket reaches the center, gas is now at high pressure and is forced out of a port located in the center of the fixed scrolls
- During compression, several pockets are compressed simultaneously resulting in a smooth continuous compression cycle
- Continuous flank contact, maintained by centrifugal force, minimizes gas leakage and maximizes efficiency
- Compressor is tolerant to the effects of slugging and contaminants

- If this occurs, scrolls separate, allowing liquid or contaminants to be worked toward the center and discharged
- A 24-volt DC solenoid valve inside the compressor controls staging

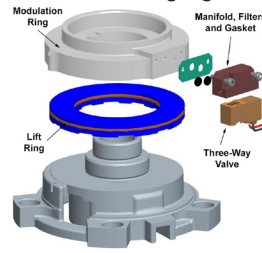

- When the 3-way solenoid is energized it moves the lift ring assembly to block the ports and the compressor operates at full-load or 100% capacity
- When the solenoid is de-energized the lift ring assembly moves to unblock the compressor

ports and the compressor operates at part-load or approximately 67% of its full-load capacity

- The “loading” and “unloading” of the two stage scroll is done “on the fly” without shutting off the single-speed compressor motor between stages

Crankcase Heater

- Crankcase heater(s) prevents migration of liquid refrigerant into compressor(s) and ensures proper compressor lubrication

CABINET

- 9 Heavy-gauge, pre-painted steel cabinet
- Removable panels for unit servicing
- 10 Heavy duty steel base rails raise the unit off of mounting surface
- Unit lifting holes and forklift slots furnished in base rails
- See dimension drawings
- 11 Control Box
- Control box located in separate compartment in unit cabinet
- All controls are pre-wired at the factory
- Control box is large enough for field installed DDC or other field supplied control modules

Options/Accessories

Field Installed

Combination Coil/Hail Guards

- Heavy gauge steel frame with expanded metal mesh to protect the outdoor coil from damage

FEATURES AND BENEFITS

CONTROLS

Options/Accessories

Field Installed

Low Ambient Control

- Air conditioning units operate satisfactorily down to 45°F outdoor air temperature without any additional controls
- Kit allows unit operation down to 0°F
- Head pressure speed controller reduces outdoor fan operation during low ambient conditions until head pressure rises to the setpoint
- Pressure transducers are mounted on the liquid lines
- High pressure switches are furnished to replace existing switches
- Wiring harnesses are furnished for simple plug-in wiring to fans and controller

Indoor Air Quality (CO₂) Sensors

- Monitors CO₂ levels
- Adjusts economizer dampers as needed

Thermostat

- Thermostat is not furnished with unit and must be ordered extra

Aftermarket Unit Controller Options

- See Options/Accessories table for selection

Aftermarket Unit Controller Options

- See Options/Accessories table for selection

ELECTRICAL

Field Installed

GFI Service Outlets (2)

- 115V ground fault circuit interrupter (GFCI) type
- Non-powered
- Field wired

SEQUENCE OF OPERATION

The outdoor unit and indoor unit cycle on demand from the room thermostat.

For details on the outdoor unit component operation based on thermostat demand, refer to the table below.

EL072KCSST, EL090KCSST

| Thermostat Demand | ² Input Signals at Terminal Strip | Compressor Output | | Fan | | | |
|----------------------------|--|-------------------|-----|-----------|-----|-----|-----|
| | | (B1) | --- | (B4) | --- | --- | --- |
| (¹ Key Number) | (TB14) | (B1) | --- | (B4) | --- | --- | --- |
| STANDBY | 24V | OFF | --- | OFF | --- | --- | --- |
| COOLING 1 | C1 | LOW | --- | ON | --- | --- | --- |
| COOLING 2 | C1+C2 | HIGH | --- | ON | --- | --- | --- |

EL120KCSST

| Thermostat Demand | ² Input Signals at Terminal Strip | Compressor Output | | Fans | | | |
|----------------------------|--|-------------------|-----|-----------|-----------|-----|-----|
| | | (B1) | --- | (B4) | (B5) | --- | --- |
| (¹ Key Number) | (TB14) | (B1) | --- | (B4) | (B5) | --- | --- |
| STANDBY | 24V | OFF | --- | OFF | OFF | --- | --- |
| COOLING 1 | C1 | LOW | --- | ON | ON | --- | --- |
| COOLING 2 | C1+C2 | HIGH | --- | ON | ON | --- | --- |

EL120KCSDT

| Thermostat Demand | ² Input Signals at Terminal Strip | Compressor Output | | Fans | | | |
|----------------------------|--|-------------------|-------------|-----------|-----------|-----|-----|
| | | (B1) | (B2) | (B4) | (B5) | --- | --- |
| (¹ Key Number) | (TB14) | (B1) | (B2) | (B4) | (B5) | --- | --- |
| STANDBY | 24V | OFF | OFF | OFF | OFF | --- | --- |
| COOLING 1 | C1 | LOW | OFF | ON | ON | --- | --- |
| COOLING 2 | C1+C2 | LOW | LOW | ON | ON | --- | --- |
| COOLING 3 | C1+C2+C3 | HIGH | HIGH | ON | ON | --- | --- |

EL150KCSDT

| Thermostat Demand | ² Input Signals at Terminal Strip | Compressor Output | | Fans | | | |
|----------------------------|--|-------------------|-------------|-----------|-----------|-----|-----|
| | | (B1) | (B2) | (B4) | (B5) | --- | --- |
| (¹ Key Number) | (TB14) | (B1) | (B2) | (B4) | (B5) | --- | --- |
| STANDBY | 24V | OFF | OFF | OFF | OFF | --- | --- |
| COOLING 1 | C1 | LOW | OFF | ON | OFF | --- | --- |
| COOLING 2 | C1+C2 | LOW | LOW | ON | ON | --- | --- |
| COOLING 3 | C1+C2+C3 | HIGH | HIGH | ON | ON | --- | --- |

EL180KCSDT, EL240KCSDT

| Thermostat Demand | ² Input Signals at Terminal Strip | Compressor Output | | Fans | | | |
|----------------------------|--|-------------------|-------------|-----------|-----------|-----------|-----------|
| | | (B1) | (B2) | (B4) | (B5) | (B21) | (B22) |
| (¹ Key Number) | (TB14) | (B1) | (B2) | (B4) | (B5) | (B21) | (B22) |
| STANDBY | 24V | OFF | OFF | OFF | OFF | OFF | OFF |
| COOLING 1 | C1 | LOW | OFF | ON | ON | OFF | OFF |
| COOLING 2 | C1+C2 | LOW | LOW | ON | ON | ON | ON |
| COOLING 3 | C1+C2+C3 | HIGH | HIGH | ON | ON | ON | ON |

¹ Refer to Component Label or Wiring Diagram for key numbers.

² 24V input signals measured between one TB14 connection listed and TB14-C connection.

OPTIONAL CONVENTIONAL TEMPERATURE CONTROL SYSTEMS

CS7500 Commercial 7-Day Programmable Thermostat



- Four-Stage Heating / Three-Stage Cooling
- Universal Multi-Stage
- Intuitive Touchscreen Interface
- Automatic Changeover between Heating and Cooling
- Full Seven-Day Programming
- Four Time Periods Per Day
- Temperature and Humidity Control
- One-Touch Away Mode
- Holiday Scheduling
- Smooth Setback Recovery (SSR)
- Performance Reports
- Notifications/Reminders
- Dehumidification Control for Split Systems and Rooftop Units
- Economizer Relay Control
- Backlit Display
- Wallplate Furnished
- FDD, ASHRAE and IECC Compliant

CS3000 Commercial 5-2 Day Programmable Thermostat



- Two-Stage Heating / Two-Stage Cooling
- Conventional Systems
- Intuitive Interface
- 5-2 Day Programming
- Program Hold
- Remote Indoor Temperature Sensing
- Smooth Setback Recovery (SSR)
- Economizer Relay Control
- Maintenance/Filter/Service Reminders
- Backlit Display
- Wallplate Furnished
- Simple Up and Down Temperature Control

Optional Accessory

Cooling Stage-Up Timer Relay

- Allows the unit to attain an additional stage of cooling without the need for extra thermostat connections
- Adjustable - 1 to 1023 seconds
- Mounts internal to unit

OPTIONAL CONVENTIONAL TEMPERATURE CONTROL SYSTEMS

BACnet Compatible Thermostat With Reheat



- 7-Day Programmable
- For units with or without dehumidification
- BTL listed MS/TP ensures compatibility with any BACnet system
- Built-in control programs for conventional and heat pump applications
- Conventional systems up to 3-stage heat and 3-stage cool
- Heat pumps with 1 or 2 compressors and up to 2-stage auxiliary heat
- On-board temperature and humidity sensor
- Multiple configurable inputs and outputs enable advanced control strategies
- Set-up Wizard enables rapid system configuration
- No special tools required for installation or commissioning
- Seven-day (2, 4 or 6 event) occupancy scheduling per day
- Backlit 5-inch LCD touchscreen

| Description | Catalog No. | |
|--|---|--------------|
| CS7500 Commercial 7-Day Programmable Thermostat | | |
| CS7500 7-Day Thermostat | 24K41 | |
| Sensors/Accessories | ¹ Remote non-adjustable wall-mount 20k | 47W36 |
| | ¹ Remote non-adjustable wall-mount 10k | 47W37 |
| | Remote non-adjustable discharge air (duct mount) | 19L22 |
| | Outdoor temperature sensor | X2658 |
| CS3000 5-2 Day Programmable Thermostat | | |
| CS3000 5-2 Day Thermostat | 11Y05 | |
| Sensor/Accessories | Remote non-adjustable wall mount 10k averaging | 47W37 |
| | Thermostat wall mounting plate | X2659 |
| Optional Accessory | | |
| | Cooling Stage-Up Timer Relay | 24G40 |
| BACnet 7-Day Programmable Thermostat | | |
| BACnet 7-Day Thermostat | 24C57 | |
| Universal Thermostat Guard with Lock (clear) | | |
| | Inside Dimensions (H x W x D) 5-7/8 x 8-3/8 x 3 in. | 39P21 |

¹ 1 Remote wall-mount sensors can be applied in any of the following combinations:
 One Sensor - (1) 47W36, Two Sensors - (2) 47W37, Three Sensors - (2) 47W36 and (1) 47W37
 Four Sensors - (4) 47W36, Five Sensors - (3) 47W36 and (2) 47W37

SPECIFICATIONS

6 TON | 7.5 TON

| Model | | EL072KCSST | EL090KCSST |
|---------------------------------|---|--|---|
| Nominal Tonnage | | 6 | 7.5 |
| Connections (sweat) | Liquid line (OD) - in. | (1) 3/8 | (1) 5/8 |
| | Suction line (OD) - in. | (1) 1-1/8 | (1) 1-1/8 |
| Refrigerant | Factory Charge | R-454B holding charge (2 lbs. per circuit) | |
| | Circuits | 1 | 1 |
| | ¹ Field charge (25 ft. line set) | 15 lbs. 0 oz. (includes holding charge) | 19 lbs. 0 oz. (includes holding charge) |
| Compressor Type (Number) | | Two Stage Scroll (1) | Two Stage Scroll (1) |
| Condenser Coil | Net face area - ft. ² Outer coil | 29.3 | 29.3 |
| | Inner coil | 14.2 | 28.4 |
| | Tube diameter - in. | 3/8 | 3/8 |
| | Rows | 1.5 | 2 |
| | Fins - in. | 20 | 20 |
| Condenser Fan | Diameter - in. (Number) | 24 (1) | 24 (1) |
| | Blades | 3 | 3 |
| | Motor HP (Number) | 1/3 (1) | 1/2 (1) |
| | Total Cfm | 4700 | 5600 |
| | Rpm | 1075 | 1075 |
| | Watts | 400 | 580 |

ELECTRICAL DATA

| Line voltage data - 60Hz - 3 phase | 208/230V | 460V | 575V | 208/230V | 460V | 575V |
|--|-----------------------|-------|------|----------|-------|------|
| ² Maximum Overcurrent Protection (amps) | 45 | 20 | 15 | 60 | 25 | 20 |
| ³ Minimum circuit ampacity | 27 | 13 | 9 | 36 | 16 | 13 |
| Compressor | Number of Compressors | 1 | 1 | 1 | 1 | 1 |
| | Rated load amps | 19.2 | 9.1 | 6.2 | 26.3 | 11 |
| | Locked rotor amps | 162.3 | 70.8 | 58.2 | 178.5 | 95.3 |
| Condenser Fan Motor (1 phase) | No. of motors | 1 | 1 | 1 | 1 | 1 |
| | Full load amps | 2.4 | 1.3 | 1 | 3 | 1.5 |
| | Locked rotor amps | 4.3 | 2.4 | 1.9 | 6 | 3 |

NOTE - All units have a minimum Short Circuit Current Rating (SCCR) of 5kA.

NOTE - Extremes of operating range are plus and minus 10% of line voltage.

¹ Approximate field provided charge with 25 ft. line set. Refer to unit installation instructions for detailed charging information.

Refer to the Lennox Refrigerant Piping Manual to determine refrigerant charge required with longer length refrigerant lines.

² HACR type circuit breaker or fuse.

³ Refer to National or Canadian Electrical Code manual to determine wire, fuse and disconnect size requirements.

SPECIFICATIONS

10 TON

| Model | | EL120KCSST | EL120KCSDT |
|---------------------------------|---|--|--|
| Nominal Tonnage | | 10 | 10 |
| Connections (sweat) | Liquid line (OD) - in. | (1) 5/8 | (2) 3/8 |
| | Suction line (OD) - in. | (1) 1-1/8 | (2) 1-1/8 |
| Refrigerant | Factory Charge | R-454B holding charge (2 lbs. per circuit) | |
| | Circuits | 1 | 2 |
| | ¹ Field charge (25 ft. line set) Circuit 1 | 21 lbs. 0 oz. (includes holding charge) | 10 lbs. 12 oz. (includes holding charge) |
| | Circuit 2 | - - - | 10 lbs. 12 oz. (includes holding charge) |
| Compressor Type (Number) | | Two Stage Scroll (1) | Two Stage Scroll (2) |
| Condenser Coil | Net face area - ft. ² Outer coil | 29.3 | 29.3 |
| | Inner coil | 28.4 | 28.4 |
| | Tube diameter - in. | 3/8 | 3/8 |
| | Rows | 2 | 2 |
| | Fins - in. | 20 | 20 |
| Condenser Fans | Diameter - in. (Number) | 24 (2) | 24 (2) |
| | Blades | 3 | 3 |
| | Motor HP (Number) | 1/3 (2) | 1/3 (2) |
| | Total Cfm | 8300 | 8300 |
| | Rpm | 1075 | 1075 |
| | Watts | 830 | 830 |

ELECTRICAL DATA

| Line voltage data - 60Hz - 3 phase | 208/230V | 460V | 575V | 208/230V | 460V | 575V | |
|--|---------------------------|-----------|-----------|-----------|-------------|-----------|-----------|
| ² Maximum Overcurrent Protection (amps) | 60 | 30 | 25 | 40 | 20 | 15 | |
| ³ Minimum circuit ampacity | 38 | 21 | 17 | 33 | 18 | 13 | |
| Compressor | Number of Compressors | 1 | 1 | 1 | 2 | 2 | |
| | Rated load amps (total) | 26.5 | 14 | 11.5 | 12.4 (24.8) | 6.5 (13) | 4.8 (9.6) |
| | Locked rotor amps (total) | 255 | 123 | 93.7 | 93 (186) | 60 (120) | 41 (82) |
| Condenser Fan Motor (1 phase) | No. of motors | 2 | 2 | 2 | 2 | 2 | |
| | Full load amps (total) | 2.4 (4.8) | 1.3 (2.6) | 1 (2) | 2.4 (4.8) | 1.3 (2.6) | 1 (2) |
| | Locked rotor amps (total) | 4.3 (8.6) | 2.4 (4.8) | 1.9 (3.8) | 4.3 (8.6) | 2.4 (4.8) | 1.9 (3.8) |

NOTE - All units have a minimum Short Circuit Current Rating (SCCR) of 5kA.

NOTE - Extremes of operating range are plus and minus 10% of line voltage.

¹ Approximate field provided charge with 25 ft. line set. Refer to unit installation instructions for detailed charging information. Refer to the Lennox Refrigerant Piping Manual to determine refrigerant charge required with longer length refrigerant lines.

² HACR type circuit breaker or fuse.

³ Refer to National or Canadian Electrical Code manual to determine wire, fuse and disconnect size requirements.

SPECIFICATIONS

12.5 TON | 20 TON

| Model | | EL150KCSDT | EL180KCSDT | EL240KCSDT |
|---------------------------------|---|--|--|---|
| Nominal Tonnage | | 12.5 | 15 | 20 |
| Connections (sweat) | Liquid line (OD) - in. | (2) 3/8 | (2) 5/8 | (2) 5/8 |
| | Suction line (OD) - in. | (2) 1-1/8 | (2) 1-1/8 | (2) 1-1/8 |
| Refrigerant | Factory Charge | R-454B holding charge (2 lbs. per circuit) | | |
| | Circuits | 2 | 2 | 2 |
| | ¹ Field charge (25 ft. line set) | Circuit 1 | 12 lbs. 8 oz. (includes holding charge) | 21 lbs. 0 oz. (includes holding charge) |
| Circuit 2 | | 12 lbs. 8 oz. (includes holding charge) | 22 lbs. 0 oz. (includes holding charge) | 19 lbs. 15 oz. (includes holding charge) |
| Compressor Type (Number) | | Two Stage Scroll (2) | Two Stage Scroll (2) | Two Stage Scroll (2) |
| Condenser Coil | Net face area - ft. ² Outer coil | 34.2 | 58.7 | 58.7 |
| | Inner coil | 33.3 | 57.7 | 57.7 |
| | Tube diameter - in. | 3/8 | 3/8 | 3/8 |
| | Rows | 2 | 2 | 2 |
| | Fins - in. | 20 | 20 | 20 |
| Condenser Fans | Diameter - in. (Number) | 24 (2) | 24 (4) | 24 (4) |
| | Blades | 4 | 3 | 3 |
| | Motor HP (Number) | 1/2 (2) | 1/3 (4) | 1/3 (4) |
| | Total Cfm | 10,300 | 16,600 | 16,600 |
| | Rpm | 1075 | 1075 | 1075 |
| | Watts | 1130 | 1660 | 1660 |

ELECTRICAL DATA

| Line voltage data - 60Hz - 3 phase | 208/230V | 460V | 575V | 208/230V | 460V | 575V | 208/230V | 460V | 575V | |
|--|---------------------------|------------------|-----------------|-----------------|----------------|-----------------|---------------|---------------|--------------|-----------------|
| ² Maximum Overcurrent Protection (amps) | 60 | 30 | 20 | 90 | 40 | 30 | 90 | 50 | 40 | |
| ³ Minimum circuit ampacity | 50 | 24 | 17 | 70 | 30 | 25 | 70 | 37 | 30 | |
| Compressor | Number of Compressors | 2 | 2 | 2 | 2 | 2 | 2 | 2 | 2 | |
| | Rated load amps (total) | 19.2 (38.4) | 9.1 (18.2) | 6.2 (12.4) | 26.3 (52.6) | 11 (22) | 9.2 (18.4) | 26.5 (53) | 14 (28) | 11.5 (23) |
| | Locked rotor amps (total) | 162.3 (324.6) | 70.8 (141.6) | 58.2 (116.4) | 178.5 (357) | 95.3 (190.6) | 65 (130) | 255 (510) | 123 (246) | 93.7 (187.4) |
| Condenser Fan Motor (1 phase) | No. of motors | 2 | 2 | 2 | 4 | 4 | 4 | 4 | 4 | |
| | Full load amps (total) | 3 (6) | 1.5 (3) | 1.2 (2.4) | 2.4 (9.6) | 1.3 (5.2) | 1 (4) | 2.4 (9.6) | 1.3 (5.2) | 1 (4) |
| | Locked rotor amps (total) | 6 (12) | 3 (6) | 2.9 (5.8) | 4.3 (17.2) | 2.4 (9.6) | 1.9 (7.6) | 4.3 (17.2) | 2.4 (9.6) | 1.9 (7.6) |

NOTE - All units have a minimum Short Circuit Current Rating (SCCR) of 5kA.

NOTE - Extremes of operating range are plus and minus 10% of line voltage.

¹ Approximate field provided charge with 25 ft. line set. Refer to unit installation instructions for detailed charging information.

Refer to the Lennox Refrigerant Piping Manual to determine refrigerant charge required with longer length refrigerant lines.

² HACR type circuit breaker or fuse.

³ Refer to National or Canadian Electrical Code manual to determine wire, fuse and disconnect size requirements.

WEIGHT DATA

| Size | Net | | Shipping | |
|----------|------|-----|----------|-----|
| | lbs. | kg | lbs. | kg |
| 072KCSST | 318 | 144 | 338 | 153 |
| 090KCSST | 345 | 157 | 365 | 166 |
| 120KCSST | 452 | 205 | 477 | 216 |
| 120KCSDT | 486 | 220 | 511 | 232 |
| 150KCSDT | 535 | 243 | 560 | 254 |
| 180KCSDT | 784 | 356 | 809 | 367 |
| 240KCSDT | 864 | 392 | 889 | 403 |

OPTIONS / ACCESSORIES**COMBINED COIL/HAIL GUARDS**

| | | | | |
|----------|----|----|-----|----|
| 072, 090 | 40 | 18 | 45 | 20 |
| 120 | 45 | 20 | 50 | 23 |
| 150 | 45 | 20 | 50 | 23 |
| 180, 240 | 90 | 41 | 100 | 45 |

OPTIONS / ACCESSORIES

| Item | Order Number | EL 072 | EL 090 | EL 120 | EL 120 | EL 150 | EL 180 | EL 240 |
|---------------------------|---|--------|--------|--------|--------|--------|--------|--------|
| | | KCSS | KCSS | KCSS | KCSD | KCSD | KCSD | KCSD |
| CABINET | | | | | | | | |
| Combined Coil/Hail Guards | 13T29 | X | X | | | | | |
| | 13T30 | | | X | X | | | |
| | 13T32 | | | | | X | | |
| | 13T37 | | | | | | X | X |
| COOLING | | | | | | | | |
| Low Ambient Control (0°F) | 37P63 | X | X | X | | | | |
| | 37P60 | | | | X | | | |
| | 37P62 | | | | | X | X | X |
| ELECTRICAL | | | | | | | | |
| GFI Service Outlets | 15 amp non-powered, field-wired (208/230V, 460V only) | 74M70 | X | X | X | X | X | X |
| | 20 amp non-powered, field-wired (575V only) | 67E01 | X | X | X | X | X | X |

INDOOR AIR QUALITY

| | | | | | | | | |
|--|-------|---|---|---|---|---|---|---|
| Sensor - Wall-mount, off-white plastic cover with LCD display | 24C58 | X | X | X | X | X | X | X |
| Sensor - Wall-mount, off-white plastic cover, no display | 87N53 | X | X | X | X | X | X | X |
| Sensor - Black plastic case with LCD display, rated for plenum mounting | 87N52 | X | X | X | X | X | X | X |
| Sensor - Wall-mount, black plastic case, no display, rated for plenum mounting | 87N54 | X | X | X | X | X | X | X |
| CO ₂ Sensor Duct Mounting Kit | 23Y47 | X | X | X | X | X | X | X |
| Aspiration Box - for duct mounting non-plenum rated CO ₂ sensor (24C58) | 90N43 | X | X | X | X | X | X | X |

NOTE - The order numbers that appear here are for ordering field installed accessories only.

O - Factory Installed with extended lead time.

X - Field Installed

SOUND DATA

| Model | Octave Band Sound Power Levels dBA, re 10 ⁻¹² Watts Center Frequency - HZ | | | | | | | ¹ Sound Rating Number (dBA) | ² Estimated Sound Pressure Level at Distance From Unit (dBA at distance in ft.) | | | | |
|------------|---|-----|-----|------|------|------|------|--|--|----|----|----|----|
| | 125 | 250 | 500 | 1000 | 2000 | 4000 | 8000 | | 3 | 5 | 10 | 15 | 50 |
| EL072KCSST | 65 | 68 | 73 | 76 | 72 | 68 | 63 | 81 | 74 | 69 | 63 | 60 | 49 |
| EL090KCSST | 64 | 69 | 73 | 77 | 74 | 70 | 63 | 81 | 74 | 69 | 63 | 60 | 49 |
| EL120KCSST | 70 | 77 | 82 | 81 | 77 | 75 | 71 | 86 | 79 | 74 | 68 | 65 | 54 |
| EL120KCSDT | 71 | 77 | 80 | 80 | 77 | 72 | 67 | 85 | 78 | 73 | 67 | 64 | 53 |
| EL150KCSDT | 68 | 77 | 80 | 82 | 78 | 73 | 65 | 86 | 79 | 74 | 68 | 65 | 54 |
| EL180KCSDT | 73 | 80 | 83 | 83 | 79 | 74 | 66 | 88 | 81 | 76 | 70 | 67 | 56 |
| EL240KCSDT | 73 | 80 | 85 | 84 | 80 | 78 | 74 | 89 | 82 | 77 | 71 | 68 | 57 |

NOTE - The octave sound power data does not include tonal correction.

¹ Tested according to AHRI Standard 270-2008 test conditions. Sound rating Number is the overall A-Weighted Sound Power Level, (LWA), dB (100 Hz to 10,000 Hz).

² Estimated sound pressure level at distance based on AHRI Standard 275-2010 method for equipment located on the ground, roof, or on side of building wall with no adjacent reflective surface within 9.8 feet. Sound pressure levels will increase based on changes to assumptions. For other applications, refer to AHRI Standard 275.

AHRI SYSTEM MATCHES**ONE OUTDOOR UNIT + ONE INDOOR UNIT**

| Model | Air Handler | Cooling Btuh | IEER | EER | AHRI Reference |
|------------|-------------|--------------|------|------|----------------|
| EL072KCSST | EL072KASS | 69,000 | 15.0 | 11.5 | 217047684 |
| EL072KCSST | EL090KASD | 71,000 | 14.8 | 11.2 | 217047685 |
| EL090KCSST | EL090KASD | 89,000 | 14.8 | 11.2 | 217047686 |
| EL090KCSST | EL120KASD | 90,000 | 14.8 | 11.2 | 217047687 |
| EL120KCSST | EL120KASD | 115,000 | 14.8 | 11.2 | 217047688 |
| EL120KCSDT | EL120KASD | 115,000 | 14.8 | 11.2 | 217047689 |
| EL150KCSDT | EL150KASD | 136,000 | 14.2 | 11.0 | 217047690 |
| EL150KCSDT | EL180KASD | 142,000 | 14.2 | 11.0 | 217047691 |
| EL180KCSDT | EL180KASD | 176,000 | 14.2 | 11.0 | 217047692 |
| EL180KCSDT | EL240KASD | 196,000 | 14.2 | 11.0 | 217047693 |
| EL240KCSDT | EL240KASD | 228,000 | 14.2 | 11.0 | 217047694 |

NOTES - Units with capacity of 65,000 Btuh or greater are AHRI Certified to AHRI Standard 340/360: 95°F outdoor air temperature, 80°F db/67°F wb entering evaporator air (minimum external duct static pressure) with 25 ft. of connecting refrigerant lines.

AHRI SYSTEM MATCHES**TWO OUTDOOR UNITS + ONE INDOOR UNIT**

| Model | Indoor Coil or Air Handler | Cooling Btuh | IEER | EER | AHRI Reference |
|----------------|----------------------------|--------------|------|------|----------------|
| (2) EL090KCSST | EL180KASD | 170,000 | 14.2 | 11.0 | 217048082 |
| (2) EL120KCSST | EL240KASD | 232,000 | 14.2 | 11.0 | 217048083 |

NOTES - Units with capacity of 65,000 Btuh or greater are AHRI Certified to AHRI Standard 340/360: 95°F outdoor air temperature, 80°F db/67°F wb entering evaporator air (minimum external duct static pressure) with 25 ft. of connecting refrigerant lines.

AHRI SYSTEM MATCHES**ONE OUTDOOR UNIT + TWO INDOOR UNITS**

| Model | Indoor Coil or Air Handler | Cooling Btuh | IEER | EER | AHRI Reference |
|------------|----------------------------|--------------|------|------|----------------|
| EL180KCSDT | (2) EL090KASD | 180,000 | 14.2 | 11.0 | 217047695 |
| EL240KCSDT | (2) EL120KASD | 232,000 | 14.4 | 11.0 | 217047696 |

NOTE - Units with capacity of 65,000 Btuh or greater are AHRI Certified to AHRI Standard 340/360: 95°F outdoor air temperature, 80°F db/67°F wb entering evaporator air (minimum external duct static pressure) with 25 ft. of connecting refrigerant lines.

UNIT CLEARANCES

EL072 and EL090

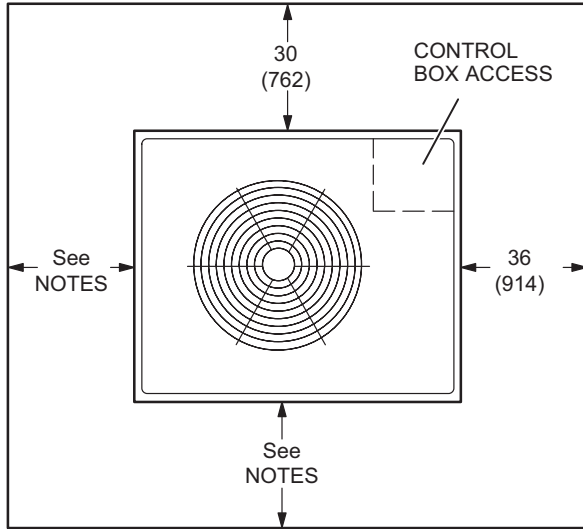

NOTES:

Clearance to one of the remaining two sides may be 12 in. (305 mm) and the final side may be 6 in. (152 mm).
 A clearance of 24 in. (610 mm) must be maintained between two units.
 48 in. (1219 mm) clearance required on top of unit.

EL120 and EL150

NOTES:

Clearance to one of the remaining two sides may be 12 in. (305 mm) and the final side may be 6 in. (152 mm).
 A clearance of 24 in. (610 mm) must be maintained between two units.
 48 in. (1219 mm) clearance required on top of unit.

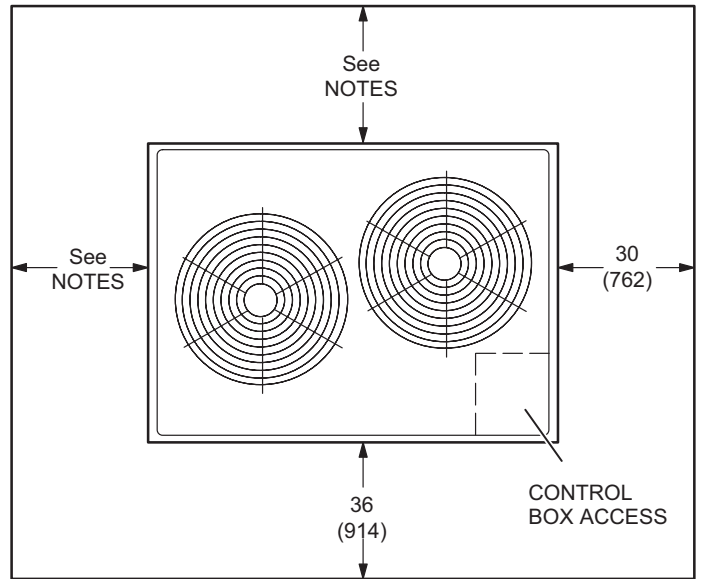

EL180 and EL240

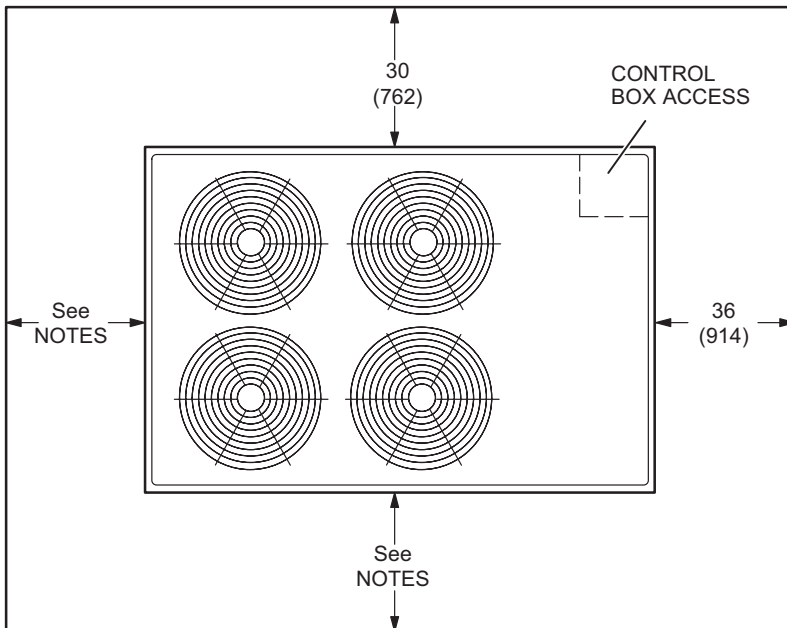

NOTES:

Clearance to one of the remaining two sides may be 12 in. (305 mm) and the final side may be 6 in. (152 mm).
 A clearance of 24 in. (610 mm) must be maintained between two units.
 48 in. (1219 mm) clearance required on top of unit.

DIMENSIONS

EL072KCSST | EL090KCSST

| Model | CORNER WEIGHTS | | | | | | | | CENTER OF GRAVITY | | | |
|------------|----------------|----|------|----|------|----|------|----|-------------------|-----|--------|-----|
| | AA | | BB | | CC | | DD | | EE | | FF | |
| | lbs. | kg | lbs. | kg | lbs. | kg | lbs. | kg | in. | mm | in. | mm |
| EL072KCSST | 66 | 30 | 73 | 33 | 97 | 44 | 82 | 37 | 23-1/4 | 591 | 19-1/4 | 489 |
| EL090KCSST | 75 | 34 | 89 | 40 | 112 | 51 | 88 | 40 | 25 | 635 | 20-1/4 | 514 |

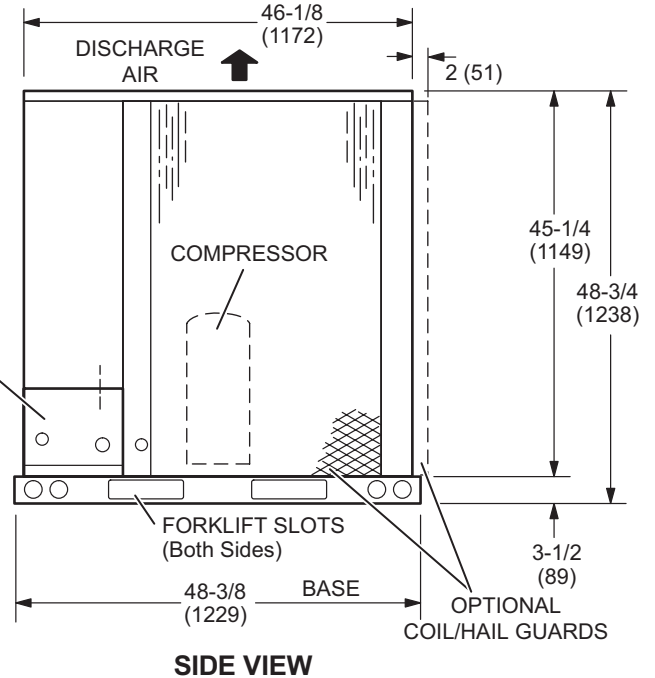
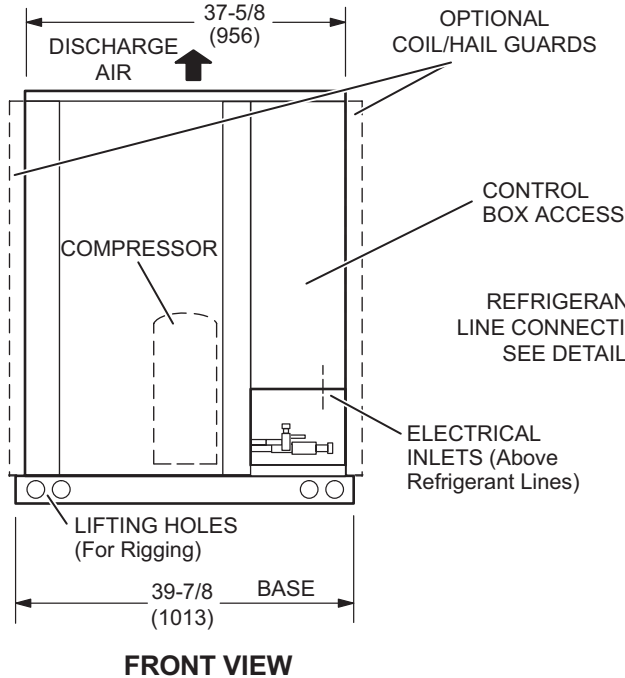
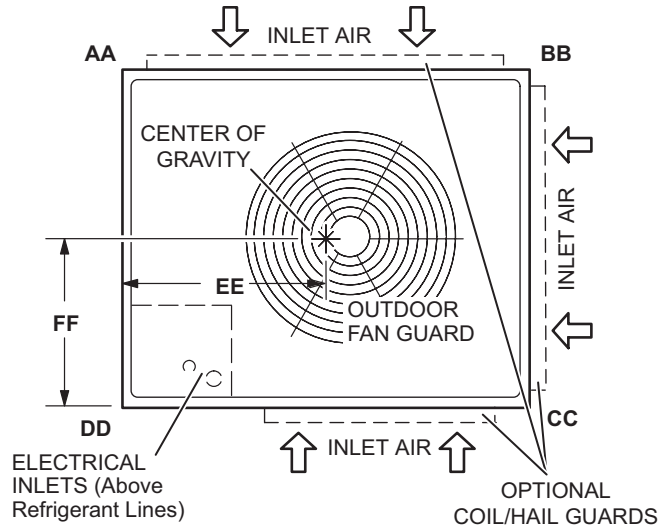
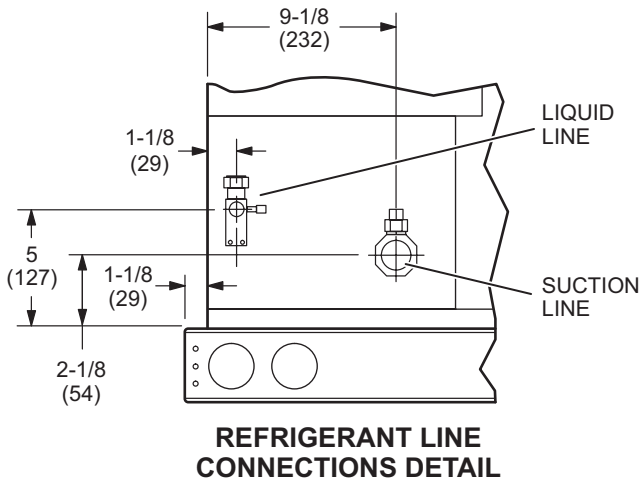

DIMENSIONS

EL120KCSST | EL120KCSDT | EL150KCSDT

| Model | CORNER WEIGHTS | | | | | | | | CENTER OF GRAVITY | | | |
|------------|----------------|----|------|----|------|----|------|----|-------------------|-----|--------|-----|
| | AA | | BB | | CC | | DD | | EE | | FF | |
| | lbs. | kg | lbs. | kg | lbs. | kg | lbs. | kg | in. | mm | in. | mm |
| EL120KCSST | 130 | 59 | 124 | 56 | 107 | 49 | 111 | 50 | 20-1/2 | 521 | 33-1/2 | 851 |
| EL120KCSDT | 122 | 55 | 119 | 54 | 127 | 58 | 131 | 59 | 21 | 533 | 28-1/2 | 724 |
| EL150KCSDT | 144 | 66 | 132 | 60 | 133 | 60 | 145 | 66 | 19 | 483 | 30 | 762 |

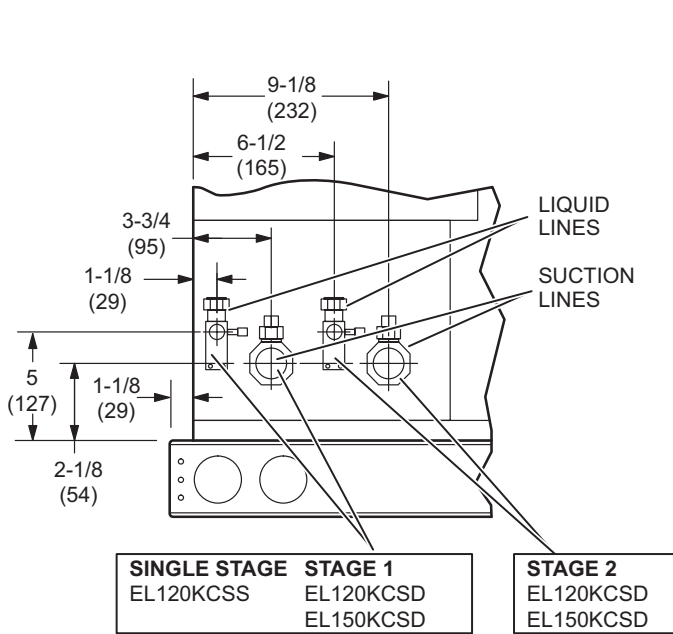

REFRIGERANT LINE CONNECTIONS DETAIL

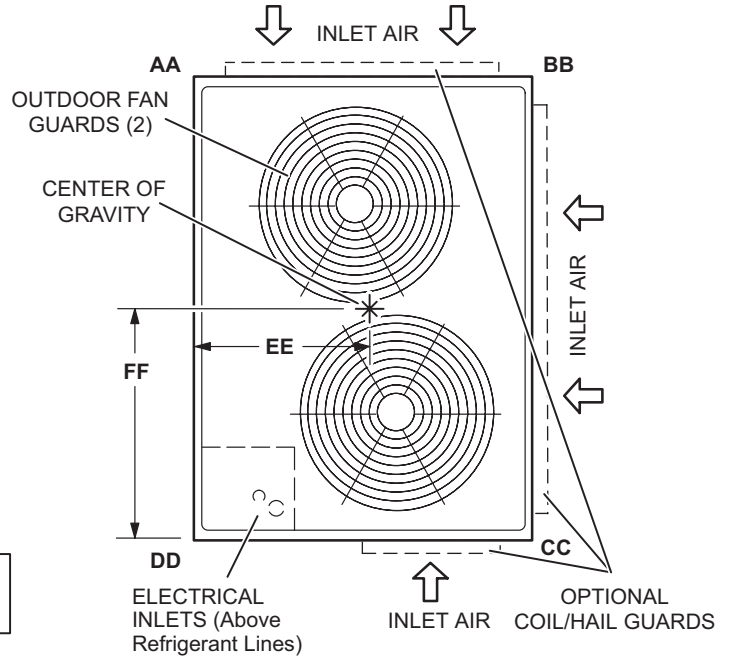

TOP VIEW

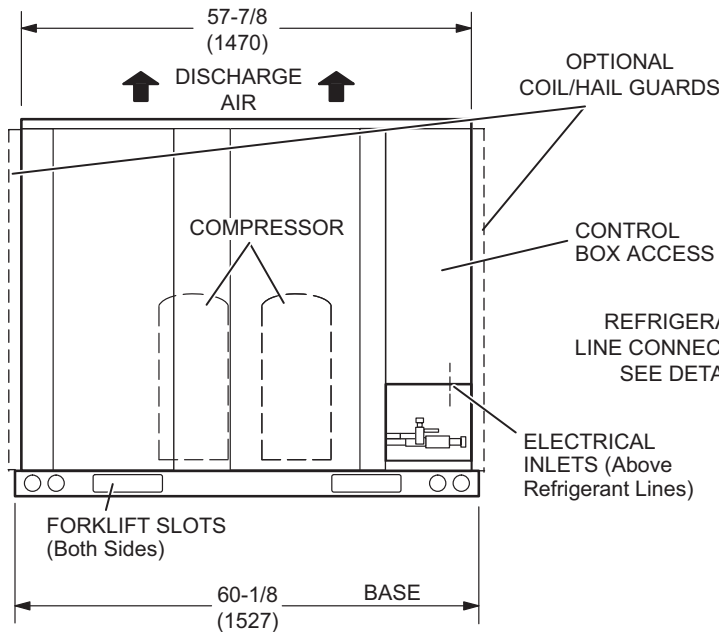

FRONT VIEW

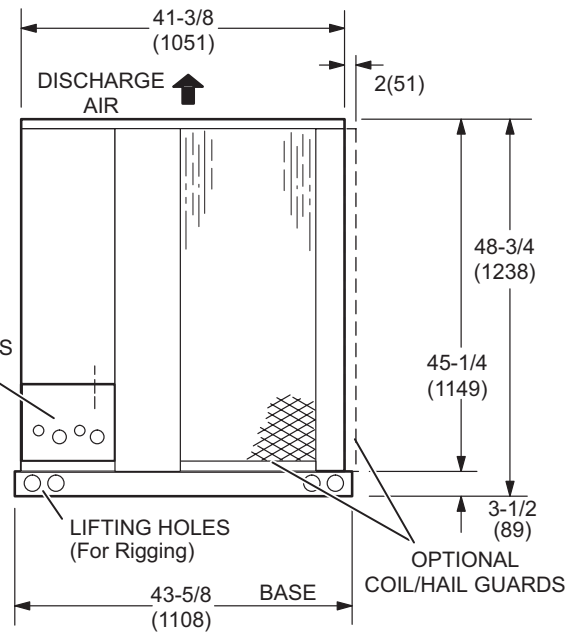

SIDE VIEW

DIMENSIONS

EL180KCSDT | EL240KCSDT

| Model | CORNER WEIGHTS | | | | | | | | CENTER OF GRAVITY | | | |
|------------|----------------|----|------|----|------|-----|------|-----|-------------------|-----|--------|-----|
| | AA | | BB | | CC | | DD | | EE | | FF | |
| | lbs. | kg | lbs. | kg | lbs. | kg | lbs. | kg | in. | mm | in. | mm |
| EL180KCSDT | 181 | 82 | 177 | 81 | 215 | 98 | 221 | 100 | 29 | 737 | 38 | 965 |
| EL240KCSDT | 192 | 87 | 189 | 86 | 232 | 105 | 238 | 108 | 29 | 737 | 37-1/2 | 953 |

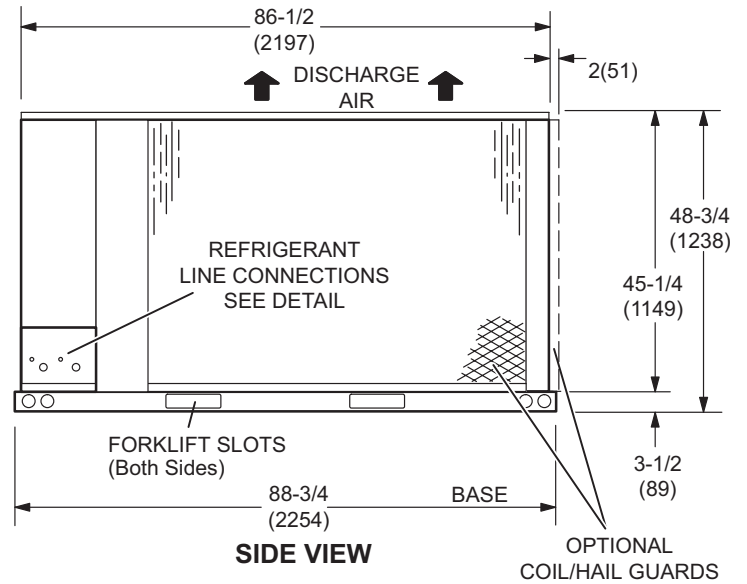
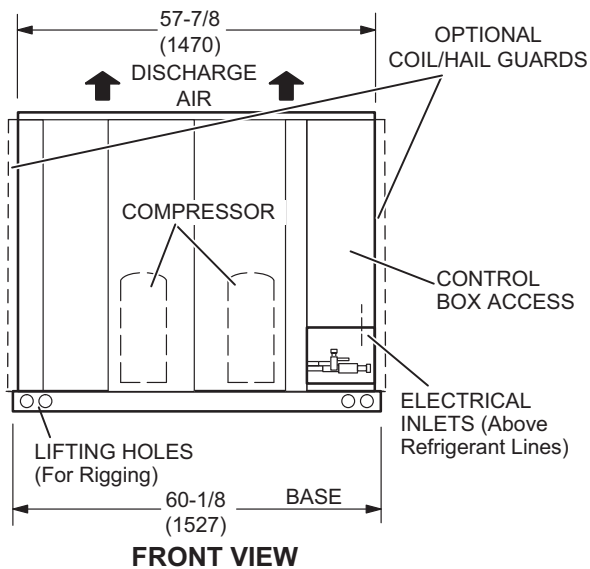
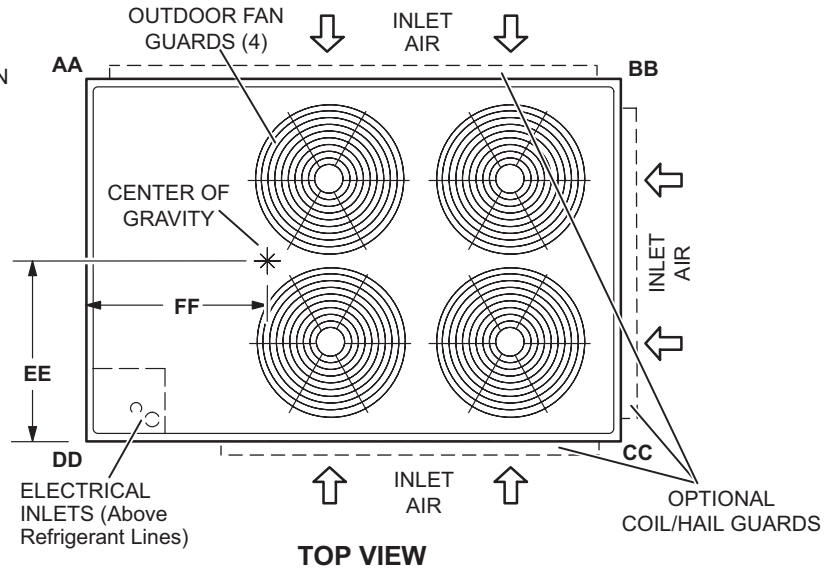
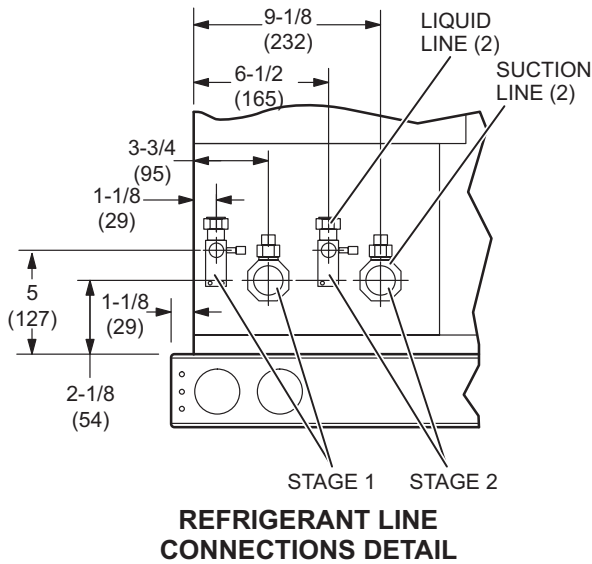

RATINGS

ONE OUTDOOR UNIT + ONE INDOOR UNIT

NOTE - For Temperatures and Capacities not shown in tables, see bulletin - Cooling Unit Rating Table Correction Factor Data in Miscellaneous Engineering Data section.

EL072KCSST + EL072KASS - 1 COMPRESSOR - PART LOAD

| Entering Wet Bulb Temperature | Total Air Volume | Outdoor Air Temperature Entering Outdoor Coil | | | | | | | | | | | | | | | | | | | |
|-------------------------------|------------------|---|-------------------|-------------------------------|------|-------|-----------------|-------------------|-------------------------------|------|-------|-----------------|-------------------|-------------------------------|------|-------|-----------------|-------------------|-------------------------------|------|------|
| | | 65°F | | | | | 75°F | | | | | 85°F | | | | | 95°F | | | | |
| | | Total Cool Cap. | Comp. Motor Input | Sensible To Total Ratio (S/T) | | | Total Cool Cap. | Comp. Motor Input | Sensible To Total Ratio (S/T) | | | Total Cool Cap. | Comp. Motor Input | Sensible To Total Ratio (S/T) | | | Total Cool Cap. | Comp. Motor Input | Sensible To Total Ratio (S/T) | | |
| | | | | Dry Bulb | | | | | Dry Bulb | | | | | Dry Bulb | | | | | Dry Bulb | | |
| cfm | kBtuh | kW | 75°F | 80°F | 85°F | kBtuh | kW | 75°F | 80°F | 85°F | kBtuh | kW | 75°F | 80°F | 85°F | kBtuh | kW | 75°F | 80°F | 85°F | |
| 63°F | 1280 | 50.3 | 2.23 | 0.69 | 0.82 | 0.95 | 48.6 | 2.57 | 0.7 | 0.83 | 0.97 | 46.7 | 2.98 | 0.71 | 0.85 | 0.99 | 44.3 | 3.44 | 0.73 | 0.88 | 1 |
| | 1600 | 53.4 | 2.22 | 0.73 | 0.89 | 1 | 51.5 | 2.57 | 0.75 | 0.91 | 1 | 49.5 | 2.98 | 0.76 | 0.93 | 1 | 46.7 | 3.44 | 0.79 | 0.96 | 1 |
| | 1920 | 55.8 | 2.22 | 0.79 | 0.96 | 1 | 53.7 | 2.57 | 0.8 | 0.98 | 1 | 51.1 | 2.98 | 0.82 | 1 | 1 | 48.9 | 3.43 | 0.85 | 1 | 1 |
| 67°F | 1280 | 53.7 | 2.22 | 0.56 | 0.67 | 0.78 | 51.9 | 2.57 | 0.57 | 0.68 | 0.79 | 49.9 | 2.98 | 0.58 | 0.69 | 0.81 | 47.3 | 3.44 | 0.58 | 0.71 | 0.83 |
| | 1600 | 56.9 | 2.21 | 0.59 | 0.71 | 0.85 | 54.9 | 2.56 | 0.6 | 0.73 | 0.87 | 52.3 | 2.97 | 0.61 | 0.74 | 0.89 | 49.7 | 3.43 | 0.62 | 0.76 | 0.92 |
| | 1920 | 59.2 | 2.2 | 0.62 | 0.76 | 0.92 | 56.5 | 2.56 | 0.63 | 0.78 | 0.94 | 54.1 | 2.97 | 0.64 | 0.8 | 0.97 | 51.4 | 3.42 | 0.66 | 0.83 | 1 |
| 71°F | 1280 | 56.9 | 2.21 | 0.44 | 0.55 | 0.65 | 55 | 2.56 | 0.45 | 0.55 | 0.66 | 52.6 | 2.97 | 0.45 | 0.56 | 0.67 | 50.4 | 3.43 | 0.46 | 0.57 | 0.68 |
| | 1600 | 60.3 | 2.2 | 0.46 | 0.58 | 0.69 | 57.7 | 2.55 | 0.46 | 0.59 | 0.7 | 55.4 | 2.96 | 0.47 | 0.6 | 0.72 | 52.7 | 3.42 | 0.48 | 0.61 | 0.74 |
| | 1920 | 62.7 | 2.19 | 0.48 | 0.61 | 0.74 | 59.9 | 2.54 | 0.48 | 0.62 | 0.75 | 57.5 | 2.95 | 0.49 | 0.63 | 0.78 | 54.6 | 3.41 | 0.5 | 0.65 | 0.79 |

EL072KCSST + EL072KASS - 1 COMPRESSOR - FULL LOAD

| Entering Wet Bulb Temperature | Total Air Volume | Outdoor Air Temperature Entering Outdoor Coil | | | | | | | | | | | | | | | | | | | |
|-------------------------------|------------------|---|-------------------|-------------------------------|------|-------|-----------------|-------------------|-------------------------------|------|-------|-----------------|-------------------|-------------------------------|------|-------|-----------------|-------------------|-------------------------------|------|------|
| | | 85°F | | | | | 95°F | | | | | 105°F | | | | | 115°F | | | | |
| | | Total Cool Cap. | Comp. Motor Input | Sensible To Total Ratio (S/T) | | | Total Cool Cap. | Comp. Motor Input | Sensible To Total Ratio (S/T) | | | Total Cool Cap. | Comp. Motor Input | Sensible To Total Ratio (S/T) | | | Total Cool Cap. | Comp. Motor Input | Sensible To Total Ratio (S/T) | | |
| | | | | Dry Bulb | | | | | Dry Bulb | | | | | Dry Bulb | | | | | Dry Bulb | | |
| cfm | kBtuh | kW | 75°F | 80°F | 85°F | kBtuh | kW | 75°F | 80°F | 85°F | kBtuh | kW | 75°F | 80°F | 85°F | kBtuh | kW | 75°F | 80°F | 85°F | |
| 63°F | 1920 | 68.1 | 4.27 | 0.73 | 0.86 | 1 | 64.7 | 4.85 | 0.74 | 0.89 | 1 | 61.4 | 5.51 | 0.76 | 0.92 | 1 | 58.2 | 6.27 | 0.78 | 0.95 | 1 |
| | 2400 | 71 | 4.3 | 0.78 | 0.95 | 1 | 67.6 | 4.88 | 0.8 | 0.98 | 1 | 64.1 | 5.54 | 0.82 | 1 | 1 | 60.4 | 6.3 | 0.85 | 1 | 1 |
| | 2880 | 73.4 | 4.33 | 0.83 | 1 | 1 | 69.9 | 4.91 | 0.86 | 1 | 1 | 66.6 | 5.57 | 0.89 | 1 | 1 | 63.2 | 6.33 | 0.92 | 1 | 1 |
| 67°F | 1920 | 71.6 | 4.31 | 0.58 | 0.71 | 0.83 | 68.2 | 4.89 | 0.6 | 0.72 | 0.85 | 65.1 | 5.56 | 0.61 | 0.74 | 0.88 | 61 | 6.31 | 0.62 | 0.76 | 0.92 |
| | 2400 | 74.7 | 4.35 | 0.62 | 0.77 | 0.91 | 71.2 | 4.92 | 0.64 | 0.78 | 0.94 | 67.5 | 5.58 | 0.65 | 0.8 | 0.97 | 63.5 | 6.34 | 0.67 | 0.83 | 1 |
| | 2880 | 77.2 | 4.37 | 0.66 | 0.82 | 0.99 | 73.4 | 4.95 | 0.67 | 0.84 | 1 | 69.6 | 5.61 | 0.69 | 0.87 | 1 | 65.5 | 6.36 | 0.71 | 0.91 | 1 |
| 71°F | 1920 | 75.3 | 4.35 | 0.46 | 0.58 | 0.69 | 71.9 | 4.93 | 0.47 | 0.58 | 0.7 | 68.2 | 5.6 | 0.47 | 0.6 | 0.72 | 64.5 | 6.35 | 0.48 | 0.62 | 0.74 |
| | 2400 | 78.6 | 4.39 | 0.49 | 0.62 | 0.74 | 75 | 4.97 | 0.49 | 0.63 | 0.76 | 71.1 | 5.64 | 0.49 | 0.64 | 0.78 | 66.9 | 6.38 | 0.5 | 0.66 | 0.81 |
| | 2880 | 81.1 | 4.43 | 0.49 | 0.65 | 0.79 | 77.2 | 5.01 | 0.5 | 0.67 | 0.82 | 73 | 5.66 | 0.51 | 0.69 | 0.85 | 68.3 | 6.4 | 0.52 | 0.71 | 0.89 |

EL072KCSST + EL090KASD - 1 COMPRESSOR - PART LOAD

| Entering Wet Bulb Temperature | Total Air Volume | Outdoor Air Temperature Entering Outdoor Coil | | | | | | | | | | | | | | | | | | | |
|-------------------------------|------------------|---|-------------------|-------------------------------|------|-------|-----------------|-------------------|-------------------------------|------|-------|-----------------|-------------------|-------------------------------|------|-------|-----------------|-------------------|-------------------------------|------|------|
| | | 65°F | | | | | 75°F | | | | | 85°F | | | | | 95°F | | | | |
| | | Total Cool Cap. | Comp. Motor Input | Sensible To Total Ratio (S/T) | | | Total Cool Cap. | Comp. Motor Input | Sensible To Total Ratio (S/T) | | | Total Cool Cap. | Comp. Motor Input | Sensible To Total Ratio (S/T) | | | Total Cool Cap. | Comp. Motor Input | Sensible To Total Ratio (S/T) | | |
| | | | | Dry Bulb | | | | | Dry Bulb | | | | | Dry Bulb | | | | | Dry Bulb | | |
| cfm | kBtuh | kW | 75°F | 80°F | 85°F | kBtuh | kW | 75°F | 80°F | 85°F | kBtuh | kW | 75°F | 80°F | 85°F | kBtuh | kW | 75°F | 80°F | 85°F | |
| 63°F | 1280 | 52.7 | 2.14 | 0.66 | 0.78 | 0.96 | 50.9 | 2.47 | 0.67 | 0.81 | 0.99 | 48.9 | 2.87 | 0.68 | 0.83 | 1 | 46.2 | 3.31 | 0.69 | 0.87 | 1 |
| | 1600 | 56 | 2.13 | 0.7 | 0.89 | 1 | 53.9 | 2.47 | 0.73 | 0.92 | 1 | 51.3 | 2.86 | 0.73 | 0.95 | 1 | 48.7 | 3.3 | 0.75 | 1 | 1 |
| | 1920 | 58.3 | 2.13 | 0.76 | 0.99 | 1 | 55.7 | 2.47 | 0.79 | 1 | 1 | 53.3 | 2.86 | 0.82 | 1 | 1 | 51.2 | 3.3 | 0.85 | 1 | 1 |
| 67°F | 1280 | 56.7 | 2.13 | 0.53 | 0.64 | 0.74 | 54.6 | 2.47 | 0.54 | 0.64 | 0.76 | 52.1 | 2.86 | 0.55 | 0.66 | 0.78 | 49.6 | 3.3 | 0.56 | 0.67 | 0.81 |
| | 1600 | 59.9 | 2.12 | 0.56 | 0.69 | 0.84 | 57.3 | 2.46 | 0.57 | 0.7 | 0.87 | 54.7 | 2.85 | 0.58 | 0.71 | 0.91 | 52.2 | 3.29 | 0.59 | 0.73 | 0.95 |
| | 1920 | 61.8 | 2.11 | 0.6 | 0.73 | 0.94 | 59.2 | 2.45 | 0.61 | 0.76 | 0.98 | 56.7 | 2.85 | 0.63 | 0.79 | 1 | 53.8 | 3.29 | 0.64 | 0.83 | 1 |
| 71°F | 1280 | 60.3 | 2.12 | 0.42 | 0.52 | 0.62 | 57.8 | 2.46 | 0.41 | 0.53 | 0.62 | 55.7 | 2.85 | 0.43 | 0.55 | 0.64 | 52.8 | 3.29 | 0.44 | 0.55 | 0.65 |
| | 1600 | 63.4 | 2.11 | 0.44 | 0.56 | 0.67 | 60.8 | 2.44 | 0.45 | 0.56 | 0.68 | 58.4 | 2.84 | 0.45 | 0.58 | 0.7 | 55.4 | 3.28 | 0.46 | 0.59 | 0.71 |
| | 1920 | 65.5 | 2.09 | 0.46 | 0.58 | 0.71 | 63.3 | 2.44 | 0.47 | 0.61 | 0.73 | 60.4 | 2.83 | 0.48 | 0.62 | 0.76 | 57.4 | 3.28 | 0.48 | 0.63 | 0.79 |

EL072KCSST + EL090KASD - 1 COMPRESSOR - FULL LOAD

| Entering Wet Bulb Temperature | Total Air Volume | Outdoor Air Temperature Entering Outdoor Coil | | | | | | | | | | | | | | | | | | | |
|-------------------------------|------------------|---|-------------------|-------------------------------|------|-------|-----------------|-------------------|-------------------------------|------|-------|-----------------|-------------------|-------------------------------|------|-------|-----------------|-------------------|-------------------------------|------|------|
| | | 85°F | | | | | 95°F | | | | | 105°F | | | | | 115°F | | | | |
| | | Total Cool Cap. | Comp. Motor Input | Sensible To Total Ratio (S/T) | | | Total Cool Cap. | Comp. Motor Input | Sensible To Total Ratio (S/T) | | | Total Cool Cap. | Comp. Motor Input | Sensible To Total Ratio (S/T) | | | Total Cool Cap. | Comp. Motor Input | Sensible To Total Ratio (S/T) | | |
| | | | | Dry Bulb | | | | | Dry Bulb | | | | | Dry Bulb | | | | | Dry Bulb | | |
| cfm | kBtuh | kW | 75°F | 80°F | 85°F | kBtuh | kW | 75°F | 80°F | 85°F | kBtuh | kW | 75°F | 80°F | 85°F | kBtuh | kW | 75°F | 80°F | 85°F | |
| 63°F | 1920 | 69.7 | 4.17 | 0.67 | 0.84 | 1 | 66.8 | 4.74 | 0.69 | 0.88 | 1 | 63 | 5.38 | 0.71 | 0.93 | 1 | 59.5 | 6.12 | 0.73 | 0.98 | 1 |
| | 2400 | 73.3 | 4.21 | 0.73 | 0.98 | 1 | 69.8 | 4.77 | 0.76 | 1 | 1 | 65.7 | 5.41 | 0.79 | 1 | 1 | 62.3 | 6.15 | 0.84 | 1 | 1 |
| | 2880 | 75.6 | 4.24 | 0.82 | 1 | 1 | 72.5 | 4.81 | 0.86 | 1 | 1 | 69 | 5.45 | 0.91 | 1 | 1 | 65.3 | 6.19 | 0.98 | 1 | 1 |
| 67°F | 1920 | 73.9 | 4.22 | 0.54 | 0.66 | 0.79 | 70.2 | 4.78 | 0.55 | 0.66 | 0.83 | 66.9 | 5.42 | 0.56 | 0.69 | 0.88 | 62.9 | 6.15 | 0.58 | 0.71 | 0.93 |
| | 2400 | 77.1 | 4.26 | 0.58 | 0.71 | 0.93 | 73.4 | 4.82 | 0.59 | 0.73 | 0.99 | 69.6 | 5.46 | 0.62 | 0.78 | 1 | 65.5 | 6.19 | 0.62 | 0.82 | 1 |
| | 2880 | 79.6 | 4.29 | 0.62 | 0.79 | 1 | 75.7 | 4.85 | 0.62 | 0.84 | 1 | 71.6 | 5.49 | 0.65 | 0.88 | 1 | 66.9 | 6.2 | 0.67 | 0.95 | 1 |
| 71°F | 1920 | 78 | 4.27 | 0.43 | 0.53 | 0.64 | 74.5 | 4.83 | 0.44 | 0.55 | 0.66 | 70.6 | 5.48 | 0.44 | 0.56 | 0.67 | 66.2 | 6.2 | 0.45 | 0.58 | 0.69 |
| | 2400 | 81.5 | 4.31 | 0.45 | 0.58 | 0.7 | 77.4 | 4.87 | 0.46 | 0.58 | 0.72 | 73 | 5.51 | 0.46 | 0.61 | 0.74 | 69.2 | 6.24 | 0.48 | 0.63 | 0.79 |
| | 2880 | 83.5 | 4.34 | 0.48 | 0.62 | 0.77 | 79.9 | 4.9 | 0.49 | 0.64 | 0.81 | 75 | 5.54 | 0.5 | 0.65 | 0.87 | 70.4 | 6.26 | 0.51 | 0.67 | 0.92 |

RATINGS

ONE OUTDOOR UNIT + ONE INDOOR UNIT

NOTE - For Temperatures and Capacities not shown in tables, see bulletin - Cooling Unit Rating Table Correction Factor Data in Miscellaneous Engineering Data section.

EL090KCSST + EL090KASD - 1 COMPRESSOR - PART LOAD

| Entering Wet Bulb Temperature | Total Air Volume | Outdoor Air Temperature Entering Outdoor Coil | | | | | | | | | | | | | | | | | | | |
|-------------------------------|------------------|---|-------------------|-------------------------------|------|-------|-----------------|-------------------|-------------------------------|------|-------|-----------------|-------------------|-------------------------------|------|-------|-----------------|-------------------|-------------------------------|------|------|
| | | 65°F | | | | | 75°F | | | | | 85°F | | | | | 95°F | | | | |
| | | Total Cool Cap. | Comp. Motor Input | Sensible To Total Ratio (S/T) | | | Total Cool Cap. | Comp. Motor Input | Sensible To Total Ratio (S/T) | | | Total Cool Cap. | Comp. Motor Input | Sensible To Total Ratio (S/T) | | | Total Cool Cap. | Comp. Motor Input | Sensible To Total Ratio (S/T) | | |
| | | | | Dry Bulb | | | | | Dry Bulb | | | | | Dry Bulb | | | | | Dry Bulb | | |
| cfm | kBtuh | kW | 75°F | 80°F | 85°F | kBtuh | kW | 75°F | 80°F | 85°F | kBtuh | kW | 75°F | 80°F | 85°F | kBtuh | kW | 75°F | 80°F | 85°F | |
| 63°F | 1600 | 67.2 | 2.87 | 0.66 | 0.79 | 0.95 | 64.5 | 3.37 | 0.68 | 0.81 | 0.98 | 61.7 | 3.93 | 0.69 | 0.83 | 1 | 58.2 | 4.57 | 0.7 | 0.87 | 1 |
| | 2000 | 70.9 | 2.84 | 0.71 | 0.88 | 1 | 67.7 | 3.35 | 0.72 | 0.91 | 1 | 64.7 | 3.92 | 0.74 | 0.95 | 1 | 61.1 | 4.56 | 0.77 | 0.99 | 1 |
| | 2400 | 73.8 | 2.82 | 0.77 | 0.98 | 1 | 70.4 | 3.34 | 0.79 | 1 | 1 | 66.9 | 3.91 | 0.82 | 1 | 1 | 63.8 | 4.55 | 0.85 | 1 | 1 |
| 67°F | 1600 | 71.8 | 2.83 | 0.54 | 0.65 | 0.74 | 68.6 | 3.35 | 0.55 | 0.65 | 0.77 | 65.6 | 3.92 | 0.56 | 0.67 | 0.78 | 62.3 | 4.55 | 0.57 | 0.68 | 0.82 |
| | 2000 | 75.8 | 2.81 | 0.57 | 0.69 | 0.84 | 72.2 | 3.33 | 0.58 | 0.7 | 0.87 | 68.7 | 3.9 | 0.59 | 0.72 | 0.9 | 65.1 | 4.54 | 0.6 | 0.74 | 0.94 |
| | 2400 | 78 | 2.79 | 0.61 | 0.74 | 0.93 | 74.8 | 3.32 | 0.61 | 0.77 | 0.97 | 71.1 | 3.89 | 0.63 | 0.79 | 1 | 67.4 | 4.53 | 0.64 | 0.83 | 1 |
| 71°F | 1600 | 75.9 | 2.81 | 0.43 | 0.53 | 0.63 | 72.9 | 3.32 | 0.43 | 0.54 | 0.64 | 69.7 | 3.9 | 0.44 | 0.54 | 0.65 | 66.2 | 4.54 | 0.45 | 0.55 | 0.66 |
| | 2000 | 80.1 | 2.78 | 0.45 | 0.57 | 0.67 | 77.1 | 3.3 | 0.45 | 0.57 | 0.68 | 73.1 | 3.88 | 0.46 | 0.58 | 0.7 | 69.4 | 4.53 | 0.47 | 0.59 | 0.72 |
| | 2400 | 82.8 | 2.76 | 0.47 | 0.6 | 0.72 | 79.3 | 3.28 | 0.47 | 0.6 | 0.74 | 75.6 | 3.87 | 0.48 | 0.62 | 0.77 | 71.8 | 4.52 | 0.49 | 0.64 | 0.78 |

EL090KCSST + EL090KASD - 1 COMPRESSOR - FULL LOAD

| Entering Wet Bulb Temperature | Total Air Volume | Outdoor Air Temperature Entering Outdoor Coil | | | | | | | | | | | | | | | | | | | |
|-------------------------------|------------------|---|-------------------|-------------------------------|------|-------|-----------------|-------------------|-------------------------------|------|-------|-----------------|-------------------|-------------------------------|------|-------|-----------------|-------------------|-------------------------------|------|------|
| | | 85°F | | | | | 95°F | | | | | 105°F | | | | | 115°F | | | | |
| | | Total Cool Cap. | Comp. Motor Input | Sensible To Total Ratio (S/T) | | | Total Cool Cap. | Comp. Motor Input | Sensible To Total Ratio (S/T) | | | Total Cool Cap. | Comp. Motor Input | Sensible To Total Ratio (S/T) | | | Total Cool Cap. | Comp. Motor Input | Sensible To Total Ratio (S/T) | | |
| | | | | Dry Bulb | | | | | Dry Bulb | | | | | Dry Bulb | | | | | Dry Bulb | | |
| cfm | kBtuh | kW | 75°F | 80°F | 85°F | kBtuh | kW | 75°F | 80°F | 85°F | kBtuh | kW | 75°F | 80°F | 85°F | kBtuh | kW | 75°F | 80°F | 85°F | |
| 63°F | 2400 | 91.2 | 6.13 | 0.7 | 0.83 | 1 | 86.4 | 6.86 | 0.71 | 0.87 | 1 | 82.1 | 7.7 | 0.73 | 0.9 | 1 | 77.9 | 8.65 | 0.75 | 0.94 | 1 |
| | 3000 | 95.6 | 6.2 | 0.75 | 0.94 | 1 | 90.5 | 6.93 | 0.77 | 0.98 | 1 | 86.3 | 7.78 | 0.8 | 1 | 1 | 80.7 | 8.7 | 0.84 | 1 | 1 |
| | 3600 | 98.5 | 6.24 | 0.83 | 1 | 1 | 93.7 | 6.98 | 0.85 | 1 | 1 | 89.3 | 7.83 | 0.89 | 1 | 1 | 84.4 | 8.76 | 0.94 | 1 | 1 |
| 67°F | 2400 | 96.7 | 6.21 | 0.57 | 0.67 | 0.79 | 91.8 | 6.95 | 0.58 | 0.69 | 0.83 | 87.2 | 7.79 | 0.59 | 0.71 | 0.86 | 82.3 | 8.72 | 0.6 | 0.73 | 0.91 |
| | 3000 | 101 | 6.28 | 0.61 | 0.74 | 0.9 | 96.1 | 7.03 | 0.62 | 0.75 | 0.94 | 90.6 | 7.85 | 0.63 | 0.78 | 0.99 | 84.5 | 8.79 | 0.66 | 0.82 | 1 |
| | 3600 | 104.5 | 6.34 | 0.64 | 0.8 | 1 | 99 | 7.07 | 0.65 | 0.83 | 1 | 93.1 | 7.89 | 0.68 | 0.87 | 1 | 87.9 | 8.83 | 0.69 | 0.92 | 1 |
| 71°F | 2400 | 102.2 | 6.3 | 0.45 | 0.55 | 0.66 | 97.6 | 7.05 | 0.46 | 0.56 | 0.67 | 92.6 | 7.89 | 0.46 | 0.58 | 0.69 | 86.8 | 8.81 | 0.47 | 0.59 | 0.72 |
| | 3000 | 107.1 | 6.38 | 0.48 | 0.6 | 0.72 | 101.2 | 7.12 | 0.48 | 0.6 | 0.73 | 96 | 7.95 | 0.49 | 0.63 | 0.75 | 90 | 8.87 | 0.5 | 0.65 | 0.8 |
| | 3600 | 109.7 | 6.43 | 0.49 | 0.64 | 0.78 | 104.2 | 7.17 | 0.5 | 0.65 | 0.82 | 98.5 | 8 | 0.52 | 0.67 | 0.85 | 92 | 8.91 | 0.52 | 0.69 | 0.9 |

EL090KCSST + EL120KASD - 1 COMPRESSOR - PART LOAD

| Entering Wet Bulb Temperature | Total Air Volume | Outdoor Air Temperature Entering Outdoor Coil | | | | | | | | | | | | | | | | | | | |
|-------------------------------|------------------|---|-------------------|-------------------------------|------|-------|-----------------|-------------------|-------------------------------|------|-------|-----------------|-------------------|-------------------------------|------|-------|-----------------|-------------------|-------------------------------|------|------|
| | | 65°F | | | | | 75°F | | | | | 85°F | | | | | 95°F | | | | |
| | | Total Cool Cap. | Comp. Motor Input | Sensible To Total Ratio (S/T) | | | Total Cool Cap. | Comp. Motor Input | Sensible To Total Ratio (S/T) | | | Total Cool Cap. | Comp. Motor Input | Sensible To Total Ratio (S/T) | | | Total Cool Cap. | Comp. Motor Input | Sensible To Total Ratio (S/T) | | |
| | | | | Dry Bulb | | | | | Dry Bulb | | | | | Dry Bulb | | | | | Dry Bulb | | |
| cfm | kBtuh | kW | 75°F | 80°F | 85°F | kBtuh | kW | 75°F | 80°F | 85°F | kBtuh | kW | 75°F | 80°F | 85°F | kBtuh | kW | 75°F | 80°F | 85°F | |
| 63°F | 1600 | 67.7 | 2.79 | 0.72 | 0.84 | 0.96 | 65 | 3.28 | 0.74 | 0.86 | 0.99 | 62 | 3.83 | 0.75 | 0.88 | 1 | 58.6 | 4.45 | 0.76 | 0.91 | 1 |
| | 2000 | 71.5 | 2.76 | 0.77 | 0.91 | 1 | 68.6 | 3.26 | 0.79 | 0.94 | 1 | 65 | 3.82 | 0.82 | 0.96 | 1 | 61.6 | 4.44 | 0.83 | 0.99 | 1 |
| | 2400 | 74.5 | 2.75 | 0.82 | 0.99 | 1 | 70.8 | 3.25 | 0.84 | 1 | 1 | 67.5 | 3.81 | 0.87 | 1 | 1 | 64.4 | 4.43 | 0.89 | 1 | 1 |
| 67°F | 1600 | 72.2 | 2.76 | 0.59 | 0.7 | 0.81 | 69.5 | 3.26 | 0.6 | 0.71 | 0.82 | 66 | 3.81 | 0.6 | 0.73 | 0.84 | 62.8 | 4.43 | 0.62 | 0.74 | 0.86 |
| | 2000 | 76.4 | 2.73 | 0.62 | 0.75 | 0.88 | 72.7 | 3.24 | 0.63 | 0.76 | 0.9 | 69.4 | 3.8 | 0.64 | 0.79 | 0.93 | 65.6 | 4.42 | 0.66 | 0.8 | 0.96 |
| | 2400 | 78.8 | 2.71 | 0.65 | 0.8 | 0.95 | 75.4 | 3.23 | 0.66 | 0.82 | 0.98 | 71.8 | 3.78 | 0.68 | 0.85 | 1 | 68.3 | 4.42 | 0.7 | 0.87 | 1 |
| 71°F | 1600 | 77 | 2.73 | 0.47 | 0.57 | 0.68 | 73.5 | 3.23 | 0.47 | 0.58 | 0.69 | 70.3 | 3.8 | 0.49 | 0.59 | 0.7 | 67 | 4.42 | 0.49 | 0.6 | 0.72 |
| | 2000 | 80.7 | 2.7 | 0.49 | 0.61 | 0.73 | 77.4 | 3.21 | 0.49 | 0.62 | 0.74 | 73.9 | 3.78 | 0.5 | 0.63 | 0.76 | 70 | 4.4 | 0.5 | 0.65 | 0.78 |
| | 2400 | 83.8 | 2.67 | 0.51 | 0.65 | 0.78 | 80.3 | 3.2 | 0.51 | 0.66 | 0.8 | 76.5 | 3.77 | 0.52 | 0.67 | 0.83 | 72.5 | 4.4 | 0.52 | 0.69 | 0.86 |

EL090KCSST + EL120KASD - 1 COMPRESSOR - FULL LOAD

| Entering Wet Bulb Temperature | Total Air Volume | Outdoor Air Temperature Entering Outdoor Coil | | | | | | | | | | | | | | | | | | | |
|-------------------------------|------------------|---|-------------------|-------------------------------|------|-------|-----------------|-------------------|-------------------------------|------|-------|-----------------|-------------------|-------------------------------|------|-------|-----------------|-------------------|-------------------------------|------|------|
| | | 85°F | | | | | 95°F | | | | | 105°F | | | | | 115°F | | | | |
| | | Total Cool Cap. | Comp. Motor Input | Sensible To Total Ratio (S/T) | | | Total Cool Cap. | Comp. Motor Input | Sensible To Total Ratio (S/T) | | | Total Cool Cap. | Comp. Motor Input | Sensible To Total Ratio (S/T) | | | Total Cool Cap. | Comp. Motor Input | Sensible To Total Ratio (S/T) | | |
| | | | | Dry Bulb | | | | | Dry Bulb | | | | | Dry Bulb | | | | | Dry Bulb | | |
| cfm | kBtuh | kW | 75°F | 80°F | 85°F | kBtuh | kW | 75°F | 80°F | 85°F | kBtuh | kW | 75°F | 80°F | 85°F | kBtuh | kW | 75°F | 80°F | 85°F | |
| 63°F | 2400 | 92.9 | 5.99 | 0.75 | 0.87 | 1 | 88.6 | 6.72 | 0.76 | 0.9 | 1 | 84.4 | 7.54 | 0.78 | 0.92 | 1 | 78.8 | 8.45 | 0.8 | 0.96 | 1 |
| | 3000 | 97.4 | 6.06 | 0.8 | 0.96 | 1 | 92.6 | 6.79 | 0.82 | 0.99 | 1 | 87.5 | 7.6 | 0.85 | 1 | 1 | 82.4 | 8.51 | 0.88 | 1 | 1 |
| | 3600 | 100.7 | 6.12 | 0.86 | 1 | 1 | 96.2 | 6.85 | 0.89 | 1 | 1 | 91.6 | 7.67 | 0.92 | 1 | 1 | 86.7 | 8.58 | 0.96 | 1 | 1 |
| 67°F | 2400 | 98.7 | 6.08 | 0.6 | 0.72 | 0.84 | 94 | 6.81 | 0.62 | 0.74 | 0.87 | 89.2 | 7.63 | 0.64 | 0.76 | 0.89 | 84 | 8.53 | 0.64 | 0.78 | 0.93 |
| | 3000 | 103.7 | 6.16 | 0.64 | 0.78 | 0.93 | 98.4 | 6.88 | 0.66 | 0.8 | 0.96 | 93.3 | 7.69 | 0.67 | 0.83 | 0.99 | 86.6 | 8.59 | 0.7 | 0.85 | 1 |
| | 3600 | 107.1 | 6.22 | 0.69 | 0.85 | 1 | 101.2 | 6.93 | 0.7 | 0.87 | 1 | 95.6 | 7.74 | 0.72 | 0.9 | 1 | 89.5 | 8.64 | 0.75 | 0.94 | 1 |
| 71°F | 2400 | 104.9 | 6.18 | 0.48 | 0.59 | 0.71 | 100.1 | 6.91 | 0.48 | 0.61 | 0.72 | 94.3 | 7.72 | 0.49 | 0.62 | 0.74 | 88.8 | 8.62 | 0.5 | 0.63 | 0.76 |
| | 3000 | 109.4 | 6.25 | 0.5 | 0.63 | 0.76 | 104 | 6.98 | 0.5 | 0.65 | 0.79 | 98.4 | 7.79 | 0.52 | 0.67 | 0.81 | 91.9 | 8.68 | 0.54 | 0.69 | 0.85 |
| | 3600 | 113 | 6.32 | 0.53 | 0.68 | 0.83 | 106.7 | 7.03 | 0.53 | 0.7 | 0.86 | 100.5 | 7.83 | 0.54 | 0.72 | 0.89 | 94.2 | 8.73 | 0.56 | 0.75 | 0.92 |

RATINGS

ONE OUTDOOR UNIT + ONE INDOOR UNIT

NOTE - For Temperatures and Capacities not shown in tables, see bulletin - Cooling Unit Rating Table Correction Factor Data in Miscellaneous Engineering Data section.

EL120KCSST + EL120KASD - 1 COMPRESSOR - PART LOAD

| Entering Wet Bulb Temperature | Total Air Volume | Outdoor Air Temperature Entering Outdoor Coil | | | | | | | | | | | | | | | | | | | |
|-------------------------------|------------------|---|-------------------|-------------------------------|------|-------|-----------------|-------------------|-------------------------------|------|-------|-----------------|-------------------|-------------------------------|------|-------|-----------------|-------------------|-------------------------------|------|------|
| | | 65°F | | | | | 75°F | | | | | 85°F | | | | | 95°F | | | | |
| | | Total Cool Cap. | Comp. Motor Input | Sensible To Total Ratio (S/T) | | | Total Cool Cap. | Comp. Motor Input | Sensible To Total Ratio (S/T) | | | Total Cool Cap. | Comp. Motor Input | Sensible To Total Ratio (S/T) | | | Total Cool Cap. | Comp. Motor Input | Sensible To Total Ratio (S/T) | | |
| | | | | Dry Bulb | | | | | Dry Bulb | | | | | Dry Bulb | | | | | Dry Bulb | | |
| cfm | kBtuh | kW | 75°F | 80°F | 85°F | kBtuh | kW | 75°F | 80°F | 85°F | kBtuh | kW | 75°F | 80°F | 85°F | kBtuh | kW | 75°F | 80°F | 85°F | |
| 63°F | 2080 | 84.2 | 3.35 | 0.69 | 0.82 | 0.98 | 81.1 | 3.92 | 0.71 | 0.83 | 1 | 77 | 4.55 | 0.72 | 0.87 | 1 | 73.2 | 5.27 | 0.74 | 0.9 | 1 |
| | 2600 | 89 | 3.34 | 0.74 | 0.91 | 1 | 85.1 | 3.9 | 0.76 | 0.95 | 1 | 80.9 | 4.54 | 0.78 | 0.98 | 1 | 76.3 | 5.25 | 0.8 | 1 | 1 |
| | 3120 | 92.3 | 3.34 | 0.8 | 1 | 1 | 88.4 | 3.89 | 0.82 | 1 | 1 | 84.7 | 4.53 | 0.86 | 1 | 1 | 80.5 | 5.24 | 0.89 | 1 | 1 |
| 67°F | 2080 | 90.1 | 3.34 | 0.56 | 0.67 | 0.78 | 86.3 | 3.9 | 0.57 | 0.68 | 0.79 | 82.3 | 4.53 | 0.58 | 0.7 | 0.82 | 78 | 5.25 | 0.59 | 0.71 | 0.86 |
| | 2600 | 94.1 | 3.33 | 0.6 | 0.73 | 0.87 | 90.6 | 3.89 | 0.61 | 0.74 | 0.9 | 86.2 | 4.52 | 0.61 | 0.76 | 0.93 | 81.7 | 5.23 | 0.63 | 0.78 | 0.98 |
| | 3120 | 97.5 | 3.33 | 0.64 | 0.78 | 0.97 | 93.5 | 3.88 | 0.65 | 0.8 | 1 | 89.5 | 4.51 | 0.66 | 0.83 | 1 | 84.3 | 5.23 | 0.67 | 0.87 | 1 |
| 71°F | 2080 | 95.1 | 3.33 | 0.45 | 0.55 | 0.65 | 91.6 | 3.88 | 0.45 | 0.56 | 0.66 | 87.6 | 4.52 | 0.45 | 0.57 | 0.68 | 82.9 | 5.23 | 0.46 | 0.58 | 0.7 |
| | 2600 | 99.9 | 3.33 | 0.47 | 0.59 | 0.7 | 96.1 | 3.87 | 0.47 | 0.6 | 0.72 | 92 | 4.51 | 0.48 | 0.61 | 0.74 | 87.2 | 5.22 | 0.49 | 0.62 | 0.76 |
| | 3120 | 103.4 | 3.32 | 0.49 | 0.63 | 0.76 | 99.4 | 3.87 | 0.5 | 0.64 | 0.77 | 95.1 | 4.5 | 0.51 | 0.66 | 0.8 | 89.7 | 5.21 | 0.51 | 0.68 | 0.84 |

EL120KCSST + EL120KASD - 1 COMPRESSOR - FULL LOAD

| Entering Wet Bulb Temperature | Total Air Volume | Outdoor Air Temperature Entering Outdoor Coil | | | | | | | | | | | | | | | | | | | |
|-------------------------------|------------------|---|-------------------|-------------------------------|------|-------|-----------------|-------------------|-------------------------------|------|-------|-----------------|-------------------|-------------------------------|------|-------|-----------------|-------------------|-------------------------------|------|------|
| | | 85°F | | | | | 95°F | | | | | 105°F | | | | | 115°F | | | | |
| | | Total Cool Cap. | Comp. Motor Input | Sensible To Total Ratio (S/T) | | | Total Cool Cap. | Comp. Motor Input | Sensible To Total Ratio (S/T) | | | Total Cool Cap. | Comp. Motor Input | Sensible To Total Ratio (S/T) | | | Total Cool Cap. | Comp. Motor Input | Sensible To Total Ratio (S/T) | | |
| | | | | Dry Bulb | | | | | Dry Bulb | | | | | Dry Bulb | | | | | Dry Bulb | | |
| cfm | kBtuh | kW | 75°F | 80°F | 85°F | kBtuh | kW | 75°F | 80°F | 85°F | kBtuh | kW | 75°F | 80°F | 85°F | kBtuh | kW | 75°F | 80°F | 85°F | |
| 63°F | 3200 | 115.3 | 7.24 | 0.72 | 0.87 | 1 | 111 | 8.07 | 0.73 | 0.9 | 1 | 104.5 | 8.96 | 0.75 | 0.94 | 1 | 99.4 | 10 | 0.77 | 0.97 | 1 |
| | 4000 | 120.5 | 7.33 | 0.77 | 0.98 | 1 | 115.8 | 8.15 | 0.81 | 1 | 1 | 109.8 | 9.05 | 0.83 | 1 | 1 | 103.6 | 10.08 | 0.87 | 1 | 1 |
| | 4800 | 125 | 7.4 | 0.85 | 1 | 1 | 119.9 | 8.22 | 0.89 | 1 | 1 | 114.9 | 9.14 | 0.93 | 1 | 1 | 109.4 | 10.18 | 0.97 | 1 | 1 |
| 67°F | 3200 | 123.1 | 7.37 | 0.58 | 0.7 | 0.83 | 116.8 | 8.17 | 0.6 | 0.71 | 0.86 | 111.4 | 9.08 | 0.61 | 0.73 | 0.9 | 104.3 | 10.09 | 0.62 | 0.75 | 0.93 |
| | 4000 | 128 | 7.46 | 0.62 | 0.76 | 0.94 | 121.6 | 8.24 | 0.62 | 0.78 | 0.98 | 115.9 | 9.16 | 0.66 | 0.81 | 1 | 108.8 | 10.18 | 0.66 | 0.85 | 1 |
| | 4800 | 131.3 | 7.53 | 0.66 | 0.84 | 1 | 125.8 | 8.32 | 0.68 | 0.86 | 1 | 119.3 | 9.22 | 0.69 | 0.9 | 1 | 111.1 | 10.23 | 0.71 | 0.96 | 1 |
| 71°F | 3200 | 130.2 | 7.49 | 0.46 | 0.57 | 0.68 | 124.2 | 8.28 | 0.47 | 0.58 | 0.7 | 117.9 | 9.19 | 0.47 | 0.6 | 0.71 | 111.4 | 10.22 | 0.48 | 0.61 | 0.74 |
| | 4000 | 135 | 7.58 | 0.49 | 0.62 | 0.75 | 129.2 | 8.37 | 0.49 | 0.63 | 0.76 | 122.2 | 9.27 | 0.5 | 0.64 | 0.79 | 115.7 | 10.3 | 0.51 | 0.66 | 0.82 |
| | 4800 | 139.4 | 7.65 | 0.5 | 0.65 | 0.81 | 133 | 8.43 | 0.52 | 0.68 | 0.84 | 126.2 | 9.34 | 0.53 | 0.7 | 0.88 | 118 | 10.34 | 0.54 | 0.71 | 0.93 |

RATINGS

ONE OUTDOOR UNIT + ONE INDOOR UNIT

NOTE - For Temperatures and Capacities not shown in tables, see bulletin - Cooling Unit Rating Table Correction Factor Data in Miscellaneous Engineering Data section.

EL120KCSDT + EL120KASD - 1 COMPRESSOR - PART LOAD

| Entering Wet Bulb Temperature | Total Air Volume | Outdoor Air Temperature Entering Outdoor Coil | | | | | | | | | | | | | | | | | | | |
|-------------------------------|------------------|---|-------------------|-------------------------------|------|-------|-----------------|-------------------|-------------------------------|------|-------|-----------------|-------------------|-------------------------------|------|-------|-----------------|-------------------|-------------------------------|------|------|
| | | 65°F | | | | | 75°F | | | | | 85°F | | | | | 95°F | | | | |
| | | Total Cool Cap. | Comp. Motor Input | Sensible To Total Ratio (S/T) | | | Total Cool Cap. | Comp. Motor Input | Sensible To Total Ratio (S/T) | | | Total Cool Cap. | Comp. Motor Input | Sensible To Total Ratio (S/T) | | | Total Cool Cap. | Comp. Motor Input | Sensible To Total Ratio (S/T) | | |
| | | | | Dry Bulb | | | | | Dry Bulb | | | | | Dry Bulb | | | | | Dry Bulb | | |
| cfm | kBtuh | kW | 75°F | 80°F | 85°F | kBtuh | kW | 75°F | 80°F | 85°F | kBtuh | kW | 75°F | 80°F | 85°F | kBtuh | kW | 75°F | 80°F | 85°F | |
| 63°F | 2080 | 42.8 | 1.75 | 0.67 | 0.79 | 0.98 | 41.2 | 2.04 | 0.68 | 0.81 | 1 | 39.2 | 2.39 | 0.69 | 0.85 | 1 | 36.9 | 2.78 | 0.71 | 0.9 | 1 |
| | 2600 | 45.4 | 1.73 | 0.71 | 0.91 | 1 | 43.5 | 2.03 | 0.73 | 0.95 | 1 | 41.3 | 2.38 | 0.75 | 1 | 1 | 39 | 2.77 | 0.79 | 1 | 1 |
| | 3120 | 47 | 1.72 | 0.79 | 1 | 1 | 45.3 | 2.02 | 0.81 | 1 | 1 | 42.9 | 2.37 | 0.85 | 1 | 1 | 40.8 | 2.76 | 0.92 | 1 | 1 |
| 67°F | 2080 | 45.9 | 1.73 | 0.56 | 0.65 | 0.74 | 44 | 2.03 | 0.56 | 0.66 | 0.76 | 41.9 | 2.37 | 0.57 | 0.68 | 0.79 | 39.7 | 2.77 | 0.58 | 0.69 | 0.84 |
| | 2600 | 48.3 | 1.71 | 0.59 | 0.7 | 0.86 | 46.4 | 2.02 | 0.6 | 0.71 | 0.9 | 44.2 | 2.36 | 0.61 | 0.73 | 0.95 | 41.9 | 2.75 | 0.63 | 0.75 | 1 |
| | 3120 | 50.1 | 1.7 | 0.63 | 0.75 | 1 | 48.2 | 2 | 0.64 | 0.79 | 1 | 45.9 | 2.35 | 0.65 | 0.83 | 1 | 43.4 | 2.75 | 0.67 | 0.88 | 1 |
| 71°F | 2080 | 48.6 | 1.71 | 0.45 | 0.54 | 0.63 | 46.8 | 2.01 | 0.46 | 0.55 | 0.64 | 44.9 | 2.36 | 0.47 | 0.56 | 0.66 | 42.6 | 2.75 | 0.47 | 0.58 | 0.67 |
| | 2600 | 51.3 | 1.69 | 0.48 | 0.58 | 0.69 | 49.4 | 1.99 | 0.48 | 0.59 | 0.7 | 47.2 | 2.35 | 0.49 | 0.61 | 0.72 | 44.7 | 2.74 | 0.5 | 0.62 | 0.74 |
| | 3120 | 53.3 | 1.67 | 0.5 | 0.63 | 0.74 | 51.2 | 1.98 | 0.51 | 0.63 | 0.76 | 49 | 2.34 | 0.53 | 0.65 | 0.79 | 46.3 | 2.73 | 0.54 | 0.67 | 0.83 |

EL120KCSDT + EL120KASD - 2 COMPRESSORS - PART LOAD / PART LOAD

| Entering Wet Bulb Temperature | Total Air Volume | Outdoor Air Temperature Entering Outdoor Coil | | | | | | | | | | | | | | | | | | | |
|-------------------------------|------------------|---|-------------------|-------------------------------|------|-------|-----------------|-------------------|-------------------------------|------|-------|-----------------|-------------------|-------------------------------|------|-------|-----------------|-------------------|-------------------------------|------|------|
| | | 85°F | | | | | 95°F | | | | | 105°F | | | | | 115°F | | | | |
| | | Total Cool Cap. | Comp. Motor Input | Sensible To Total Ratio (S/T) | | | Total Cool Cap. | Comp. Motor Input | Sensible To Total Ratio (S/T) | | | Total Cool Cap. | Comp. Motor Input | Sensible To Total Ratio (S/T) | | | Total Cool Cap. | Comp. Motor Input | Sensible To Total Ratio (S/T) | | |
| | | | | Dry Bulb | | | | | Dry Bulb | | | | | Dry Bulb | | | | | Dry Bulb | | |
| cfm | kBtuh | kW | 75°F | 80°F | 85°F | kBtuh | kW | 75°F | 80°F | 85°F | kBtuh | kW | 75°F | 80°F | 85°F | kBtuh | kW | 75°F | 80°F | 85°F | |
| 63°F | 2400 | 88.7 | 4.68 | 0.7 | 0.91 | 1 | 83.9 | 5.46 | 0.72 | 1 | 1 | 78.2 | 6.32 | 0.75 | 1 | 1 | 72.3 | 7.26 | 0.8 | 1 | 1 |
| | 3000 | 93.1 | 4.66 | 0.76 | 1 | 1 | 87.9 | 5.44 | 0.81 | 1 | 1 | 83.2 | 6.3 | 0.93 | 1 | 1 | 78.1 | 7.24 | 1 | 1 | 1 |
| | 3600 | 97.7 | 4.64 | 0.95 | 1 | 1 | 93.1 | 5.41 | 1 | 1 | 1 | 87.8 | 6.28 | 1 | 1 | 1 | 82.2 | 7.23 | 1 | 1 | 1 |
| 67°F | 2400 | 94.9 | 4.65 | 0.58 | 0.69 | 0.83 | 90 | 5.43 | 0.59 | 0.71 | 0.91 | 84.4 | 6.3 | 0.61 | 0.73 | 1 | 77.9 | 7.24 | 0.63 | 0.76 | 1 |
| | 3000 | 99.2 | 4.63 | 0.62 | 0.75 | 1 | 93.7 | 5.41 | 0.64 | 0.78 | 1 | 87.9 | 6.28 | 0.66 | 0.87 | 1 | 81.2 | 7.23 | 0.69 | 1 | 1 |
| | 3600 | 102.8 | 4.62 | 0.68 | 0.91 | 1 | 96.7 | 5.4 | 0.69 | 1 | 1 | 90.7 | 6.27 | 0.72 | 1 | 1 | 83.2 | 7.22 | 0.76 | 1 | 1 |
| 71°F | 2400 | 101.2 | 4.63 | 0.46 | 0.57 | 0.67 | 96 | 5.4 | 0.47 | 0.58 | 0.69 | 90.1 | 6.27 | 0.49 | 0.6 | 0.71 | 83.4 | 7.23 | 0.5 | 0.63 | 0.74 |
| | 3000 | 106.2 | 4.61 | 0.49 | 0.62 | 0.73 | 100.5 | 5.38 | 0.51 | 0.64 | 0.76 | 93.8 | 6.25 | 0.52 | 0.66 | 0.84 | 87.6 | 7.22 | 0.55 | 0.69 | 0.96 |
| | 3600 | 109.6 | 4.59 | 0.53 | 0.67 | 0.86 | 103.3 | 5.38 | 0.54 | 0.69 | 0.96 | 96.4 | 6.24 | 0.58 | 0.72 | 1 | 89.8 | 7.21 | 0.59 | 0.76 | 1 |

EL120KCSDT + EL120KASD - 2 COMPRESSORS - FULL LOAD

| Entering Wet Bulb Temperature | Total Air Volume | Outdoor Air Temperature Entering Outdoor Coil | | | | | | | | | | | | | | | | | | | |
|-------------------------------|------------------|---|-------------------|-------------------------------|------|-------|-----------------|-------------------|-------------------------------|------|-------|-----------------|-------------------|-------------------------------|------|-------|-----------------|-------------------|-------------------------------|------|------|
| | | 85°F | | | | | 95°F | | | | | 105°F | | | | | 115°F | | | | |
| | | Total Cool Cap. | Comp. Motor Input | Sensible To Total Ratio (S/T) | | | Total Cool Cap. | Comp. Motor Input | Sensible To Total Ratio (S/T) | | | Total Cool Cap. | Comp. Motor Input | Sensible To Total Ratio (S/T) | | | Total Cool Cap. | Comp. Motor Input | Sensible To Total Ratio (S/T) | | |
| | | | | Dry Bulb | | | | | Dry Bulb | | | | | Dry Bulb | | | | | Dry Bulb | | |
| cfm | kBtuh | kW | 75°F | 80°F | 85°F | kBtuh | kW | 75°F | 80°F | 85°F | kBtuh | kW | 75°F | 80°F | 85°F | kBtuh | kW | 75°F | 80°F | 85°F | |
| 63°F | 3200 | 119.4 | 7.01 | 0.67 | 0.85 | 1 | 113.4 | 7.87 | 0.69 | 0.93 | 1 | 108 | 8.88 | 0.71 | 1 | 1 | 102.2 | 10.03 | 0.73 | 1 | 1 |
| | 4000 | 125 | 7.11 | 0.73 | 1 | 1 | 118.9 | 7.98 | 0.76 | 1 | 1 | 112.9 | 8.99 | 0.84 | 1 | 1 | 107.1 | 10.15 | 0.91 | 1 | 1 |
| | 4800 | 129.2 | 7.19 | 0.89 | 1 | 1 | 124.1 | 8.09 | 0.97 | 1 | 1 | 118.6 | 9.12 | 1 | 1 | 1 | 112.2 | 10.28 | 1 | 1 | 1 |
| 67°F | 3200 | 127.1 | 7.15 | 0.55 | 0.66 | 0.79 | 121.3 | 8.02 | 0.57 | 0.67 | 0.85 | 115 | 9.04 | 0.58 | 0.69 | 0.94 | 108.5 | 10.19 | 0.59 | 0.71 | 1 |
| | 4000 | 132.8 | 7.26 | 0.6 | 0.72 | 1 | 125.8 | 8.13 | 0.61 | 0.74 | 1 | 119.2 | 9.14 | 0.63 | 0.81 | 1 | 112.4 | 10.29 | 0.65 | 0.89 | 1 |
| | 4800 | 136.5 | 7.34 | 0.64 | 0.85 | 1 | 130 | 8.21 | 0.66 | 0.94 | 1 | 123.2 | 9.22 | 0.68 | 1 | 1 | 116.1 | 10.38 | 0.71 | 1 | 1 |
| 71°F | 3200 | 134.9 | 7.3 | 0.45 | 0.55 | 0.64 | 128.3 | 8.17 | 0.46 | 0.56 | 0.66 | 121.9 | 9.19 | 0.47 | 0.57 | 0.68 | 115 | 10.36 | 0.48 | 0.59 | 0.7 |
| | 4000 | 140.5 | 7.42 | 0.48 | 0.6 | 0.71 | 133.7 | 8.29 | 0.49 | 0.61 | 0.72 | 126.7 | 9.31 | 0.5 | 0.63 | 0.78 | 119.4 | 10.47 | 0.51 | 0.65 | 0.85 |
| | 4800 | 144.5 | 7.5 | 0.51 | 0.64 | 0.84 | 137.1 | 8.38 | 0.53 | 0.67 | 0.91 | 130.1 | 9.39 | 0.55 | 0.69 | 1 | 122.7 | 10.55 | 0.56 | 0.72 | 1 |

RATINGS

ONE OUTDOOR UNIT + ONE INDOOR UNIT

NOTE - For Temperatures and Capacities not shown in tables, see bulletin - Cooling Unit Rating Table Correction Factor Data in Miscellaneous Engineering Data section.

EL150KCSDT + EL150KASD - PART LOAD (1 COMPRESSOR)

| Entering Wet Bulb Temperature | Total Air Volume | Outdoor Air Temperature Entering Outdoor Coil | | | | | | | | | | | | | | | | | | | | |
|-------------------------------|------------------|---|-------------------|-------------------------------|------|-------|-----------------|-------------------|-------------------------------|------|-------|-----------------|-------------------|-------------------------------|------|-------|-----------------|-------------------|-------------------------------|------|------|--|
| | | 65°F | | | | | | 75°F | | | | | 85°F | | | | | 95°F | | | | |
| | | Total Cool Cap. | Comp. Motor Input | Sensible To Total Ratio (S/T) | | | Total Cool Cap. | Comp. Motor Input | Sensible To Total Ratio (S/T) | | | Total Cool Cap. | Comp. Motor Input | Sensible To Total Ratio (S/T) | | | Total Cool Cap. | Comp. Motor Input | Sensible To Total Ratio (S/T) | | | |
| | | | | Dry Bulb | | | | | Dry Bulb | | | | | Dry Bulb | | | | | Dry Bulb | | | |
| cfm | kBtuh | kW | 75°F | 80°F | 85°F | kBtuh | kW | 75°F | 80°F | 85°F | kBtuh | kW | 75°F | 80°F | 85°F | kBtuh | kW | 75°F | 80°F | 85°F | | |
| 63°F | 2640 | 50.9 | 2.14 | 0.69 | 0.81 | 1 | 49.2 | 2.49 | 0.7 | 0.84 | 1 | 47 | 2.89 | 0.71 | 0.88 | 1 | 44.7 | 3.35 | 0.73 | 0.93 | 1 | |
| | 3300 | 53.6 | 2.12 | 0.74 | 0.96 | 1 | 51.7 | 2.47 | 0.76 | 1 | 1 | 49.3 | 2.88 | 0.77 | 1 | 1 | 46.9 | 3.34 | 0.8 | 1 | 1 | |
| | 3960 | 55.9 | 2.11 | 0.81 | 1 | 1 | 53.7 | 2.46 | 0.85 | 1 | 1 | 51.4 | 2.86 | 0.9 | 1 | 1 | 49.2 | 3.32 | 0.95 | 1 | 1 | |
| 67°F | 2640 | 54.3 | 2.12 | 0.57 | 0.67 | 0.77 | 52.6 | 2.47 | 0.58 | 0.68 | 0.78 | 50.2 | 2.87 | 0.59 | 0.69 | 0.83 | 47.9 | 3.33 | 0.6 | 0.71 | 0.87 | |
| | 3300 | 57.3 | 2.1 | 0.61 | 0.73 | 0.91 | 55.2 | 2.45 | 0.62 | 0.74 | 0.94 | 53 | 2.85 | 0.63 | 0.76 | 0.99 | 49.8 | 3.31 | 0.65 | 0.78 | 1 | |
| | 3960 | 59.2 | 2.09 | 0.65 | 0.78 | 1 | 56.9 | 2.44 | 0.67 | 0.82 | 1 | 54.9 | 2.84 | 0.69 | 0.86 | 1 | 51.9 | 3.3 | 0.7 | 0.92 | 1 | |
| 71°F | 2640 | 57.9 | 2.09 | 0.47 | 0.56 | 0.65 | 55.9 | 2.45 | 0.47 | 0.57 | 0.66 | 53.6 | 2.85 | 0.48 | 0.58 | 0.68 | 51.1 | 3.31 | 0.48 | 0.59 | 0.69 | |
| | 3300 | 60.7 | 2.07 | 0.49 | 0.6 | 0.71 | 58.6 | 2.43 | 0.5 | 0.61 | 0.72 | 56.1 | 2.83 | 0.51 | 0.62 | 0.74 | 53.6 | 3.29 | 0.52 | 0.64 | 0.77 | |
| | 3960 | 63 | 2.06 | 0.53 | 0.64 | 0.77 | 60.7 | 2.41 | 0.54 | 0.66 | 0.8 | 57.8 | 2.82 | 0.55 | 0.68 | 0.84 | 55.3 | 3.28 | 0.55 | 0.69 | 0.9 | |

EL150KCSDT + EL150KASD - 2 COMPRESSORS - PART LOAD / PART LOAD

| Entering Wet Bulb Temperature | Total Air Volume | Outdoor Air Temperature Entering Outdoor Coil | | | | | | | | | | | | | | | | | | | | |
|-------------------------------|------------------|---|-------------------|-------------------------------|------|-------|-----------------|-------------------|-------------------------------|------|-------|-----------------|-------------------|-------------------------------|------|-------|-----------------|-------------------|-------------------------------|------|------|--|
| | | 85°F | | | | | | 95°F | | | | | 105°F | | | | | 115°F | | | | |
| | | Total Cool Cap. | Comp. Motor Input | Sensible To Total Ratio (S/T) | | | Total Cool Cap. | Comp. Motor Input | Sensible To Total Ratio (S/T) | | | Total Cool Cap. | Comp. Motor Input | Sensible To Total Ratio (S/T) | | | Total Cool Cap. | Comp. Motor Input | Sensible To Total Ratio (S/T) | | | |
| | | | | Dry Bulb | | | | | Dry Bulb | | | | | Dry Bulb | | | | | Dry Bulb | | | |
| cfm | kBtuh | kW | 75°F | 80°F | 85°F | kBtuh | kW | 75°F | 80°F | 85°F | kBtuh | kW | 75°F | 80°F | 85°F | kBtuh | kW | 75°F | 80°F | 85°F | | |
| 63°F | 3000 | 102.5 | 5.65 | 0.74 | 0.96 | 1 | 97.9 | 6.54 | 0.76 | 1 | 1 | 92 | 7.56 | 0.78 | 1 | 1 | 86.3 | 8.74 | 0.82 | 1 | 1 | |
| | 3750 | 107.5 | 5.63 | 0.81 | 1 | 1 | 102.6 | 6.52 | 0.86 | 1 | 1 | 97.5 | 7.55 | 0.95 | 1 | 1 | 92.1 | 8.72 | 1 | 1 | 1 | |
| | 4500 | 112.8 | 5.6 | 1 | 1 | 1 | 108 | 6.5 | 1 | 1 | 1 | 102.6 | 7.53 | 1 | 1 | 1 | 96.6 | 8.7 | 1 | 1 | 1 | |
| 67°F | 3000 | 109.5 | 5.62 | 0.61 | 0.73 | 0.88 | 104.3 | 6.52 | 0.62 | 0.75 | 0.96 | 98.7 | 7.54 | 0.64 | 0.77 | 1 | 91.8 | 8.72 | 0.66 | 0.8 | 1 | |
| | 3750 | 114.3 | 5.6 | 0.66 | 0.8 | 1 | 109 | 6.5 | 0.68 | 0.82 | 1 | 102.3 | 7.53 | 0.7 | 0.92 | 1 | 95.8 | 8.7 | 0.73 | 1 | 1 | |
| | 4500 | 118.1 | 5.58 | 0.71 | 0.96 | 1 | 112 | 6.48 | 0.73 | 1 | 1 | 104.9 | 7.52 | 0.76 | 1 | 1 | 98.4 | 8.69 | 0.8 | 1 | 1 | |
| 71°F | 3000 | 116.6 | 5.58 | 0.5 | 0.61 | 0.71 | 110.8 | 6.49 | 0.51 | 0.62 | 0.73 | 104.4 | 7.52 | 0.52 | 0.63 | 0.76 | 97.9 | 8.69 | 0.53 | 0.65 | 0.79 | |
| | 3750 | 121.2 | 5.56 | 0.53 | 0.66 | 0.78 | 115.6 | 6.46 | 0.55 | 0.68 | 0.81 | 108.8 | 7.5 | 0.55 | 0.71 | 0.88 | 101.9 | 8.67 | 0.58 | 0.73 | 0.99 | |
| | 4500 | 125 | 5.54 | 0.56 | 0.71 | 0.93 | 118.9 | 6.44 | 0.59 | 0.74 | 1 | 111.6 | 7.48 | 0.61 | 0.76 | 1 | 104.7 | 8.65 | 0.62 | 0.8 | 1 | |

EL150KCSDT + EL150KASD - 2 COMPRESSORS - FULL LOAD

| Entering Wet Bulb Temperature | Total Air Volume | Outdoor Air Temperature Entering Outdoor Coil | | | | | | | | | | | | | | | | | | | | |
|-------------------------------|------------------|---|-------------------|-------------------------------|------|-------|-----------------|-------------------|-------------------------------|------|-------|-----------------|-------------------|-------------------------------|------|-------|-----------------|-------------------|-------------------------------|------|------|--|
| | | 85°F | | | | | | 95°F | | | | | 105°F | | | | | 115°F | | | | |
| | | Total Cool Cap. | Comp. Motor Input | Sensible To Total Ratio (S/T) | | | Total Cool Cap. | Comp. Motor Input | Sensible To Total Ratio (S/T) | | | Total Cool Cap. | Comp. Motor Input | Sensible To Total Ratio (S/T) | | | Total Cool Cap. | Comp. Motor Input | Sensible To Total Ratio (S/T) | | | |
| | | | | Dry Bulb | | | | | Dry Bulb | | | | | Dry Bulb | | | | | Dry Bulb | | | |
| cfm | kBtuh | kW | 75°F | 80°F | 85°F | kBtuh | kW | 75°F | 80°F | 85°F | kBtuh | kW | 75°F | 80°F | 85°F | kBtuh | kW | 75°F | 80°F | 85°F | | |
| 63°F | 4000 | 139 | 8.12 | 0.72 | 0.91 | 1 | 133.3 | 9.26 | 0.74 | 0.97 | 1 | 125.9 | 10.55 | 0.76 | 1 | 1 | 118.8 | 12.04 | 0.78 | 1 | 1 | |
| | 5000 | 145.6 | 8.17 | 0.79 | 1 | 1 | 138.4 | 9.3 | 0.82 | 1 | 1 | 131.6 | 10.6 | 0.89 | 1 | 1 | 124.7 | 12.08 | 0.99 | 1 | 1 | |
| | 6000 | 150.7 | 8.21 | 0.94 | 1 | 1 | 144.2 | 9.35 | 1 | 1 | 1 | 137.3 | 10.65 | 1 | 1 | 1 | 130.1 | 12.12 | 1 | 1 | 1 | |
| 67°F | 4000 | 146.9 | 8.18 | 0.6 | 0.71 | 0.85 | 140.5 | 9.32 | 0.61 | 0.73 | 0.92 | 133.1 | 10.61 | 0.62 | 0.75 | 0.99 | 125.9 | 12.09 | 0.65 | 0.77 | 1 | |
| | 5000 | 153.1 | 8.23 | 0.66 | 0.78 | 1 | 146.3 | 9.37 | 0.66 | 0.8 | 1 | 138.6 | 10.66 | 0.69 | 0.87 | 1 | 130.4 | 12.13 | 0.71 | 0.96 | 1 | |
| | 6000 | 157.5 | 8.27 | 0.7 | 0.92 | 1 | 150.4 | 9.41 | 0.72 | 1 | 1 | 141.4 | 10.69 | 0.74 | 1 | 1 | 133.3 | 12.15 | 0.76 | 1 | 1 | |
| 71°F | 4000 | 155.1 | 8.25 | 0.49 | 0.6 | 0.7 | 148 | 9.39 | 0.5 | 0.61 | 0.72 | 140.4 | 10.68 | 0.51 | 0.63 | 0.74 | 132 | 12.14 | 0.53 | 0.64 | 0.76 | |
| | 5000 | 161.4 | 8.31 | 0.53 | 0.65 | 0.77 | 153.8 | 9.44 | 0.55 | 0.66 | 0.79 | 145 | 10.72 | 0.56 | 0.69 | 0.84 | 136.9 | 12.19 | 0.57 | 0.71 | 0.93 | |
| | 6000 | 165.9 | 8.35 | 0.57 | 0.7 | 0.9 | 157.4 | 9.48 | 0.58 | 0.71 | 0.99 | 149 | 10.76 | 0.59 | 0.74 | 1 | 140.3 | 12.21 | 0.62 | 0.77 | 1 | |

RATINGS

ONE OUTDOOR UNIT + ONE INDOOR UNIT

NOTE - For Temperatures and Capacities not shown in tables, see bulletin - Cooling Unit Rating Table Correction Factor Data in Miscellaneous Engineering Data section.

EL150KCSDT + EL180KASD - 1 COMPRESSOR - PART LOAD

| Entering Wet Bulb Temperature | Total Air Volume | Outdoor Air Temperature Entering Outdoor Coil | | | | | | | | | | | | | | | | | | | |
|-------------------------------|------------------|---|-------------------|-------------------------------|------|-------|-----------------|-------------------|-------------------------------|------|-------|-----------------|-------------------|-------------------------------|------|-------|-----------------|-------------------|-------------------------------|------|------|
| | | 65°F | | | | | 75°F | | | | | 85°F | | | | | 95°F | | | | |
| | | Total Cool Cap. | Comp. Motor Input | Sensible To Total Ratio (S/T) | | | Total Cool Cap. | Comp. Motor Input | Sensible To Total Ratio (S/T) | | | Total Cool Cap. | Comp. Motor Input | Sensible To Total Ratio (S/T) | | | Total Cool Cap. | Comp. Motor Input | Sensible To Total Ratio (S/T) | | |
| | | | | Dry Bulb | | | | | Dry Bulb | | | | | Dry Bulb | | | | | Dry Bulb | | |
| cfm | kBtuh | kW | 75°F | 80°F | 85°F | kBtuh | kW | 75°F | 80°F | 85°F | kBtuh | kW | 75°F | 80°F | 85°F | kBtuh | kW | 75°F | 80°F | 85°F | |
| 63°F | 2640 | 51.1 | 2.1 | 0.64 | 0.77 | 0.97 | 49.4 | 2.44 | 0.65 | 0.79 | 1 | 47.5 | 2.84 | 0.67 | 0.82 | 1 | 44.9 | 3.29 | 0.68 | 0.87 | 1 |
| | 3300 | 54.2 | 2.08 | 0.68 | 0.88 | 1 | 52.2 | 2.43 | 0.7 | 0.91 | 1 | 49.7 | 2.82 | 0.72 | 0.96 | 1 | 47.2 | 3.27 | 0.74 | 1 | 1 |
| | 3960 | 56.4 | 2.07 | 0.75 | 1 | 1 | 54 | 2.42 | 0.77 | 1 | 1 | 51.7 | 2.81 | 0.8 | 1 | 1 | 49.3 | 3.26 | 0.85 | 1 | 1 |
| 67°F | 2640 | 54.6 | 2.08 | 0.52 | 0.62 | 0.72 | 52.6 | 2.42 | 0.53 | 0.63 | 0.74 | 50.2 | 2.82 | 0.54 | 0.65 | 0.77 | 47.9 | 3.27 | 0.55 | 0.66 | 0.81 |
| | 3300 | 57.3 | 2.06 | 0.55 | 0.67 | 0.83 | 55.3 | 2.41 | 0.56 | 0.68 | 0.86 | 53.3 | 2.8 | 0.57 | 0.7 | 0.9 | 50.4 | 3.26 | 0.59 | 0.72 | 0.95 |
| | 3960 | 59.5 | 2.05 | 0.59 | 0.72 | 0.94 | 57.3 | 2.39 | 0.6 | 0.74 | 0.99 | 54.9 | 2.79 | 0.61 | 0.78 | 1 | 52.2 | 3.24 | 0.63 | 0.82 | 1 |
| 71°F | 2640 | 57.8 | 2.06 | 0.41 | 0.51 | 0.6 | 55.7 | 2.4 | 0.42 | 0.51 | 0.61 | 53.5 | 2.8 | 0.42 | 0.53 | 0.63 | 51.1 | 3.25 | 0.43 | 0.53 | 0.64 |
| | 3300 | 60.9 | 2.04 | 0.43 | 0.54 | 0.65 | 58.7 | 2.38 | 0.44 | 0.55 | 0.66 | 56.3 | 2.78 | 0.45 | 0.57 | 0.68 | 53.7 | 3.23 | 0.45 | 0.59 | 0.7 |
| | 3960 | 63.1 | 2.02 | 0.45 | 0.58 | 0.7 | 60.9 | 2.37 | 0.48 | 0.6 | 0.71 | 58.3 | 2.77 | 0.47 | 0.61 | 0.76 | 55.5 | 3.22 | 0.49 | 0.62 | 0.79 |

EL150KCSDT + EL180KASD - 2 COMPRESSORS - PART LOAD / PART LOAD

| Entering Wet Bulb Temperature | Total Air Volume | Outdoor Air Temperature Entering Outdoor Coil | | | | | | | | | | | | | | | | | | | |
|-------------------------------|------------------|---|-------------------|-------------------------------|------|-------|-----------------|-------------------|-------------------------------|------|-------|-----------------|-------------------|-------------------------------|------|-------|-----------------|-------------------|-------------------------------|------|------|
| | | 85°F | | | | | 95°F | | | | | 105°F | | | | | 115°F | | | | |
| | | Total Cool Cap. | Comp. Motor Input | Sensible To Total Ratio (S/T) | | | Total Cool Cap. | Comp. Motor Input | Sensible To Total Ratio (S/T) | | | Total Cool Cap. | Comp. Motor Input | Sensible To Total Ratio (S/T) | | | Total Cool Cap. | Comp. Motor Input | Sensible To Total Ratio (S/T) | | |
| | | | | Dry Bulb | | | | | Dry Bulb | | | | | Dry Bulb | | | | | Dry Bulb | | |
| cfm | kBtuh | kW | 75°F | 80°F | 85°F | kBtuh | kW | 75°F | 80°F | 85°F | kBtuh | kW | 75°F | 80°F | 85°F | kBtuh | kW | 75°F | 80°F | 85°F | |
| 63°F | 3000 | 102.7 | 5.5 | 0.7 | 0.89 | 1 | 97.6 | 6.37 | 0.71 | 0.95 | 1 | 92.4 | 7.37 | 0.73 | 1 | 1 | 86.5 | 8.51 | 0.76 | 1 | 1 |
| | 3750 | 107.9 | 5.48 | 0.75 | 1 | 1 | 102.5 | 6.36 | 0.79 | 1 | 1 | 97.3 | 7.36 | 0.85 | 1 | 1 | 92 | 8.49 | 0.93 | 1 | 1 |
| | 4500 | 112.5 | 5.46 | 0.88 | 1 | 1 | 108 | 6.34 | 0.93 | 1 | 1 | 102.5 | 7.33 | 1 | 1 | 1 | 96.8 | 8.47 | 1 | 1 | 1 |
| 67°F | 3000 | 109.4 | 5.48 | 0.57 | 0.68 | 0.83 | 104 | 6.35 | 0.58 | 0.7 | 0.88 | 98.4 | 7.35 | 0.59 | 0.72 | 0.94 | 92.2 | 8.49 | 0.61 | 0.74 | 1 |
| | 3750 | 114.5 | 5.45 | 0.6 | 0.74 | 1 | 108.9 | 6.33 | 0.63 | 0.76 | 1 | 102.8 | 7.33 | 0.64 | 0.82 | 1 | 96.3 | 8.47 | 0.66 | 0.89 | 1 |
| | 4500 | 118.4 | 5.43 | 0.65 | 0.84 | 1 | 112.5 | 6.31 | 0.67 | 0.9 | 1 | 105.8 | 7.32 | 0.69 | 0.97 | 1 | 98.6 | 8.46 | 0.71 | 1 | 1 |
| 71°F | 3000 | 116 | 5.45 | 0.45 | 0.56 | 0.66 | 110.4 | 6.32 | 0.45 | 0.57 | 0.68 | 104.4 | 7.32 | 0.47 | 0.58 | 0.7 | 98 | 8.46 | 0.48 | 0.6 | 0.73 |
| | 3750 | 120.8 | 5.42 | 0.47 | 0.6 | 0.72 | 115.3 | 6.3 | 0.47 | 0.62 | 0.74 | 108.6 | 7.31 | 0.48 | 0.63 | 0.78 | 101.9 | 8.44 | 0.49 | 0.66 | 0.85 |
| | 4500 | 124.6 | 5.4 | 0.49 | 0.65 | 0.81 | 118.2 | 6.28 | 0.5 | 0.67 | 0.86 | 112 | 7.29 | 0.52 | 0.69 | 0.94 | 104.2 | 8.43 | 0.54 | 0.71 | 1 |

EL150KCSDT + EL180KASD - 2 COMPRESSORS - FULL LOAD

| Entering Wet Bulb Temperature | Total Air Volume | Outdoor Air Temperature Entering Outdoor Coil | | | | | | | | | | | | | | | | | | | |
|-------------------------------|------------------|---|-------------------|-------------------------------|------|-------|-----------------|-------------------|-------------------------------|------|-------|-----------------|-------------------|-------------------------------|------|-------|-----------------|-------------------|-------------------------------|------|------|
| | | 85°F | | | | | 95°F | | | | | 105°F | | | | | 115°F | | | | |
| | | Total Cool Cap. | Comp. Motor Input | Sensible To Total Ratio (S/T) | | | Total Cool Cap. | Comp. Motor Input | Sensible To Total Ratio (S/T) | | | Total Cool Cap. | Comp. Motor Input | Sensible To Total Ratio (S/T) | | | Total Cool Cap. | Comp. Motor Input | Sensible To Total Ratio (S/T) | | |
| | | | | Dry Bulb | | | | | Dry Bulb | | | | | Dry Bulb | | | | | Dry Bulb | | |
| cfm | kBtuh | kW | 75°F | 80°F | 85°F | kBtuh | kW | 75°F | 80°F | 85°F | kBtuh | kW | 75°F | 80°F | 85°F | kBtuh | kW | 75°F | 80°F | 85°F | |
| 63°F | 4000 | 139.2 | 8.01 | 0.67 | 0.85 | 1 | 132.7 | 9.13 | 0.69 | 0.89 | 1 | 126 | 10.4 | 0.7 | 0.94 | 1 | 118.5 | 11.87 | 0.73 | 1 | 1 |
| | 5000 | 145.2 | 8.05 | 0.73 | 1 | 1 | 138.5 | 9.17 | 0.76 | 1 | 1 | 131.2 | 10.45 | 0.8 | 1 | 1 | 124.1 | 11.91 | 0.86 | 1 | 1 |
| | 6000 | 149.9 | 8.09 | 0.83 | 1 | 1 | 143.3 | 9.21 | 0.87 | 1 | 1 | 136.4 | 10.49 | 0.93 | 1 | 1 | 129.1 | 11.94 | 0.99 | 1 | 1 |
| 67°F | 4000 | 146.7 | 8.07 | 0.55 | 0.66 | 0.8 | 140.1 | 9.18 | 0.56 | 0.67 | 0.84 | 133.1 | 10.46 | 0.58 | 0.69 | 0.9 | 125.6 | 11.92 | 0.59 | 0.71 | 0.96 |
| | 5000 | 153 | 8.12 | 0.59 | 0.71 | 0.95 | 145.7 | 9.24 | 0.61 | 0.73 | 1 | 137.6 | 10.5 | 0.62 | 0.78 | 1 | 130 | 11.95 | 0.64 | 0.83 | 1 |
| | 6000 | 157.7 | 8.16 | 0.63 | 0.8 | 1 | 149.4 | 9.27 | 0.64 | 0.85 | 1 | 141.5 | 10.54 | 0.66 | 0.91 | 1 | 133.1 | 11.98 | 0.68 | 0.98 | 1 |
| 71°F | 4000 | 153.4 | 8.12 | 0.43 | 0.54 | 0.65 | 147 | 9.25 | 0.45 | 0.55 | 0.66 | 139.2 | 10.52 | 0.44 | 0.57 | 0.68 | 131.5 | 11.96 | 0.45 | 0.59 | 0.7 |
| | 5000 | 159.9 | 8.18 | 0.45 | 0.59 | 0.7 | 152.1 | 9.3 | 0.46 | 0.6 | 0.72 | 144.3 | 10.56 | 0.48 | 0.61 | 0.75 | 135.7 | 12 | 0.51 | 0.63 | 0.81 |
| | 6000 | 164.6 | 8.22 | 0.5 | 0.63 | 0.78 | 156.4 | 9.34 | 0.5 | 0.64 | 0.83 | 147.8 | 10.6 | 0.52 | 0.66 | 0.89 | 138.3 | 12.02 | 0.51 | 0.69 | 0.96 |

RATINGS

ONE OUTDOOR UNIT + ONE INDOOR UNIT

NOTE - For Temperatures and Capacities not shown in tables, see bulletin - Cooling Unit Rating Table Correction Factor Data in Miscellaneous Engineering Data section.

EL180KCSDT + EL180KASD - 1 COMPRESSOR - PART LOAD

| Entering Wet Bulb Temperature | Total Air Volume | Outdoor Air Temperature Entering Outdoor Coil | | | | | | | | | | | | | | | | | | | | |
|-------------------------------|------------------|---|-------------------|-------------------------------|------|-------|-----------------|-------------------|-------------------------------|------|-------|-----------------|-------------------|-------------------------------|------|-------|-----------------|-------------------|-------------------------------|------|------|--|
| | | 65°F | | | | | | 75°F | | | | | 85°F | | | | | 95°F | | | | |
| | | Total Cool Cap. | Comp. Motor Input | Sensible To Total Ratio (S/T) | | | Total Cool Cap. | Comp. Motor Input | Sensible To Total Ratio (S/T) | | | Total Cool Cap. | Comp. Motor Input | Sensible To Total Ratio (S/T) | | | Total Cool Cap. | Comp. Motor Input | Sensible To Total Ratio (S/T) | | | |
| | | | | Dry Bulb | | | | | Dry Bulb | | | | | Dry Bulb | | | | | Dry Bulb | | | |
| cfm | kBtuh | kW | 75°F | 80°F | 85°F | kBtuh | kW | 75°F | 80°F | 85°F | kBtuh | kW | 75°F | 80°F | 85°F | kBtuh | kW | 75°F | 80°F | 85°F | | |
| 63°F | 3200 | 64.4 | 2.62 | 0.69 | 0.81 | 0.96 | 61.3 | 3.09 | 0.7 | 0.83 | 1 | 58.1 | 3.61 | 0.72 | 0.87 | 1 | 54.5 | 4.2 | 0.74 | 0.91 | 1 | |
| | 4000 | 68.4 | 2.59 | 0.73 | 0.89 | 1 | 65.1 | 3.06 | 0.75 | 0.93 | 1 | 61.4 | 3.59 | 0.77 | 0.97 | 1 | 57.5 | 4.18 | 0.81 | 1 | 1 | |
| | 4800 | 71.4 | 2.56 | 0.78 | 0.98 | 1 | 67.8 | 3.04 | 0.81 | 1 | 1 | 63.7 | 3.57 | 0.85 | 1 | 1 | 60.3 | 4.16 | 0.9 | 1 | 1 | |
| 67°F | 3200 | 68.9 | 2.59 | 0.57 | 0.67 | 0.77 | 65.7 | 3.06 | 0.58 | 0.68 | 0.79 | 62.4 | 3.58 | 0.59 | 0.7 | 0.82 | 58.6 | 4.17 | 0.6 | 0.72 | 0.9 | |
| | 4000 | 73.1 | 2.55 | 0.6 | 0.71 | 0.85 | 69.3 | 3.03 | 0.61 | 0.73 | 0.88 | 65.9 | 3.56 | 0.63 | 0.75 | 0.93 | 61.9 | 4.15 | 0.64 | 0.78 | 0.99 | |
| | 4800 | 75.7 | 2.52 | 0.63 | 0.76 | 0.94 | 72.2 | 3 | 0.64 | 0.78 | 0.98 | 68.3 | 3.54 | 0.66 | 0.82 | 1 | 63.8 | 4.14 | 0.68 | 0.87 | 1 | |
| 71°F | 3200 | 73.1 | 2.55 | 0.46 | 0.55 | 0.65 | 69.7 | 3.03 | 0.46 | 0.56 | 0.66 | 66.3 | 3.56 | 0.47 | 0.57 | 0.68 | 62.3 | 4.15 | 0.48 | 0.59 | 0.75 | |
| | 4000 | 77.1 | 2.51 | 0.48 | 0.59 | 0.69 | 73.6 | 2.99 | 0.49 | 0.6 | 0.71 | 69.9 | 3.53 | 0.49 | 0.61 | 0.73 | 65.8 | 4.12 | 0.5 | 0.63 | 0.82 | |
| | 4800 | 80.3 | 2.48 | 0.49 | 0.62 | 0.74 | 76.5 | 2.96 | 0.51 | 0.64 | 0.76 | 72.6 | 3.51 | 0.51 | 0.65 | 0.79 | 68.5 | 4.1 | 0.53 | 0.67 | 0.88 | |

EL180KCSDT + EL180KASD - 2 COMPRESSORS - PART LOAD / PART LOAD

| Entering Wet Bulb Temperature | Total Air Volume | Outdoor Air Temperature Entering Outdoor Coil | | | | | | | | | | | | | | | | | | | | |
|-------------------------------|------------------|---|-------------------|-------------------------------|------|-------|-----------------|-------------------|-------------------------------|------|-------|-----------------|-------------------|-------------------------------|------|-------|-----------------|-------------------|-------------------------------|------|------|--|
| | | 85°F | | | | | | 95°F | | | | | 105°F | | | | | 115°F | | | | |
| | | Total Cool Cap. | Comp. Motor Input | Sensible To Total Ratio (S/T) | | | Total Cool Cap. | Comp. Motor Input | Sensible To Total Ratio (S/T) | | | Total Cool Cap. | Comp. Motor Input | Sensible To Total Ratio (S/T) | | | Total Cool Cap. | Comp. Motor Input | Sensible To Total Ratio (S/T) | | | |
| | | | | Dry Bulb | | | | | Dry Bulb | | | | | Dry Bulb | | | | | Dry Bulb | | | |
| cfm | kBtuh | kW | 75°F | 80°F | 85°F | kBtuh | kW | 75°F | 80°F | 85°F | kBtuh | kW | 75°F | 80°F | 85°F | kBtuh | kW | 75°F | 80°F | 85°F | | |
| 63°F | 3600 | 128.8 | 7.11 | 0.74 | 0.91 | 1 | 120.9 | 8.29 | 0.76 | 0.97 | 1 | 112.7 | 9.56 | 0.79 | 1 | 1 | 103.4 | 11.02 | 0.85 | 1 | 1 | |
| | 4500 | 135.6 | 7.04 | 0.8 | 1 | 1 | 127.2 | 8.21 | 0.84 | 1 | 1 | 119.2 | 9.55 | 0.91 | 1 | 1 | 111.6 | 10.99 | 0.99 | 1 | 1 | |
| | 5400 | 142.1 | 7 | 0.9 | 1 | 1 | 134.1 | 8.15 | 0.97 | 1 | 1 | 126.5 | 9.45 | 1 | 1 | 1 | 118 | 10.94 | 1 | 1 | 1 | |
| 67°F | 3600 | 138.4 | 7.03 | 0.6 | 0.72 | 0.86 | 130.1 | 8.18 | 0.62 | 0.74 | 0.91 | 120.7 | 9.53 | 0.64 | 0.77 | 0.98 | 111.8 | 10.98 | 0.66 | 0.81 | 1 | |
| | 4500 | 145 | 6.98 | 0.64 | 0.78 | 1 | 135.9 | 8.14 | 0.66 | 0.81 | 1 | 126.5 | 9.45 | 0.69 | 0.87 | 1 | 116.4 | 10.96 | 0.72 | 0.95 | 1 | |
| | 5400 | 150.2 | 6.95 | 0.69 | 0.87 | 1 | 140.3 | 8.12 | 0.71 | 0.93 | 1 | 130 | 9.43 | 0.74 | 1 | 1 | 119.2 | 10.93 | 0.78 | 1 | 1 | |
| 71°F | 3600 | 147 | 6.97 | 0.48 | 0.59 | 0.7 | 138.1 | 8.13 | 0.49 | 0.61 | 0.72 | 129.1 | 9.44 | 0.5 | 0.63 | 0.75 | 119.8 | 10.92 | 0.52 | 0.65 | 0.86 | |
| | 4500 | 154.4 | 6.92 | 0.51 | 0.64 | 0.76 | 144.8 | 8.08 | 0.52 | 0.66 | 0.79 | 135.1 | 9.41 | 0.53 | 0.68 | 0.84 | 124.6 | 10.87 | 0.55 | 0.71 | 0.95 | |
| | 5400 | 160.2 | 6.87 | 0.54 | 0.68 | 0.84 | 150.1 | 8.05 | 0.55 | 0.71 | 0.9 | 139.9 | 9.38 | 0.57 | 0.74 | 0.98 | 129 | 10.84 | 0.59 | 0.77 | 1 | |

EL180KCSDT + EL180KASD - 2 COMPRESSORS - FULL LOAD

| Entering Wet Bulb Temperature | Total Air Volume | Outdoor Air Temperature Entering Outdoor Coil | | | | | | | | | | | | | | | | | | | | |
|-------------------------------|------------------|---|-------------------|-------------------------------|------|-------|-----------------|-------------------|-------------------------------|------|-------|-----------------|-------------------|-------------------------------|------|-------|-----------------|-------------------|-------------------------------|------|------|--|
| | | 85°F | | | | | | 95°F | | | | | 105°F | | | | | 115°F | | | | |
| | | Total Cool Cap. | Comp. Motor Input | Sensible To Total Ratio (S/T) | | | Total Cool Cap. | Comp. Motor Input | Sensible To Total Ratio (S/T) | | | Total Cool Cap. | Comp. Motor Input | Sensible To Total Ratio (S/T) | | | Total Cool Cap. | Comp. Motor Input | Sensible To Total Ratio (S/T) | | | |
| | | | | Dry Bulb | | | | | Dry Bulb | | | | | Dry Bulb | | | | | Dry Bulb | | | |
| cfm | kBtuh | kW | 75°F | 80°F | 85°F | kBtuh | kW | 75°F | 80°F | 85°F | kBtuh | kW | 75°F | 80°F | 85°F | kBtuh | kW | 75°F | 80°F | 85°F | | |
| 63°F | 4800 | 182.7 | 11.05 | 0.71 | 0.86 | 1 | 173.3 | 12.43 | 0.73 | 0.89 | 1 | 163.6 | 13.98 | 0.75 | 0.93 | 1 | 152.9 | 15.75 | 0.78 | 0.99 | 1 | |
| | 6000 | 192.3 | 11.14 | 0.77 | 0.96 | 1 | 181.9 | 12.51 | 0.8 | 1 | 1 | 170.5 | 14.07 | 0.83 | 1 | 1 | 159.1 | 15.81 | 0.88 | 1 | 1 | |
| | 7200 | 198.8 | 11.21 | 0.84 | 1 | 1 | 187.6 | 12.57 | 0.88 | 1 | 1 | 178.3 | 14.14 | 0.93 | 1 | 1 | 167.8 | 15.9 | 0.99 | 1 | 1 | |
| 67°F | 4800 | 195.3 | 11.18 | 0.59 | 0.69 | 0.81 | 185 | 12.54 | 0.6 | 0.71 | 0.85 | 173.8 | 14.11 | 0.61 | 0.74 | 0.89 | 163.2 | 15.86 | 0.63 | 0.76 | 0.96 | |
| | 6000 | 205 | 11.27 | 0.62 | 0.75 | 0.92 | 193.9 | 12.64 | 0.64 | 0.77 | 0.96 | 182.6 | 14.19 | 0.66 | 0.81 | 1 | 169.7 | 15.92 | 0.68 | 0.86 | 1 | |
| | 7200 | 212.2 | 11.35 | 0.66 | 0.82 | 1 | 200.5 | 12.7 | 0.68 | 0.86 | 1 | 187.4 | 14.25 | 0.7 | 0.91 | 1 | 174.6 | 15.97 | 0.73 | 0.97 | 1 | |
| 71°F | 4800 | 206.4 | 11.3 | 0.47 | 0.58 | 0.68 | 195.4 | 12.65 | 0.48 | 0.59 | 0.69 | 184.2 | 14.21 | 0.49 | 0.6 | 0.72 | 172.5 | 15.95 | 0.5 | 0.62 | 0.8 | |
| | 6000 | 216.5 | 11.4 | 0.5 | 0.62 | 0.73 | 205.5 | 12.76 | 0.51 | 0.63 | 0.75 | 193.7 | 14.32 | 0.52 | 0.65 | 0.79 | 180.5 | 16.04 | 0.53 | 0.68 | 0.88 | |
| | 7200 | 224.4 | 11.48 | 0.52 | 0.66 | 0.79 | 212.6 | 12.83 | 0.54 | 0.68 | 0.83 | 200.3 | 14.39 | 0.55 | 0.7 | 0.88 | 185.7 | 16.11 | 0.57 | 0.73 | 0.96 | |

RATINGS

ONE OUTDOOR UNIT + ONE INDOOR UNIT

NOTE - For Temperatures and Capacities not shown in tables, see bulletin - Cooling Unit Rating Table Correction Factor Data in Miscellaneous Engineering Data section.

EL180KCSDT + EL240KASD - 1 COMPRESSOR - PART LOAD

| Entering Wet Bulb Temperature | Total Air Volume | Outdoor Air Temperature Entering Outdoor Coil | | | | | | | | | | | | | | | | | | | | |
|-------------------------------|------------------|---|-------------------|-------------------------------|------|-------|-----------------|-------------------|-------------------------------|------|-------|-----------------|-------------------|-------------------------------|------|-------|-----------------|-------------------|-------------------------------|------|------|--|
| | | 65°F | | | | | | 75°F | | | | | 85°F | | | | | 95°F | | | | |
| | | Total Cool Cap. | Comp. Motor Input | Sensible To Total Ratio (S/T) | | | Total Cool Cap. | Comp. Motor Input | Sensible To Total Ratio (S/T) | | | Total Cool Cap. | Comp. Motor Input | Sensible To Total Ratio (S/T) | | | Total Cool Cap. | Comp. Motor Input | Sensible To Total Ratio (S/T) | | | |
| | | | | Dry Bulb | | | | | Dry Bulb | | | | | Dry Bulb | | | | | Dry Bulb | | | |
| cfm | kBtuh | kW | 75°F | 80°F | 85°F | kBtuh | kW | 75°F | 80°F | 85°F | kBtuh | kW | 75°F | 80°F | 85°F | kBtuh | kW | 75°F | 80°F | 85°F | | |
| 63°F | 3200 | 65.7 | 2.62 | 0.6 | 0.69 | 0.98 | 62.4 | 3.1 | 0.61 | 0.75 | 1 | 59.1 | 3.63 | 0.63 | 0.81 | 1 | 55.4 | 4.22 | 0.65 | 0.9 | 1 | |
| | 4000 | 69.6 | 2.59 | 0.64 | 0.88 | 1 | 65.9 | 3.07 | 0.66 | 0.96 | 1 | 62.2 | 3.61 | 0.68 | 1 | 1 | 58.3 | 4.2 | 0.74 | 1 | 1 | |
| | 4800 | 72.1 | 2.56 | 0.69 | 1 | 1 | 68.5 | 3.05 | 0.74 | 1 | 1 | 65.1 | 3.59 | 0.83 | 1 | 1 | 61.7 | 4.18 | 0.92 | 1 | 1 | |
| 67°F | 3200 | 70.5 | 2.58 | 0.5 | 0.58 | 0.66 | 67.2 | 3.06 | 0.51 | 0.59 | 0.68 | 63.7 | 3.6 | 0.52 | 0.61 | 0.73 | 59.9 | 4.19 | 0.53 | 0.63 | 0.93 | |
| | 4000 | 74.5 | 2.54 | 0.53 | 0.63 | 0.8 | 70.8 | 3.03 | 0.54 | 0.64 | 0.87 | 67.1 | 3.57 | 0.55 | 0.66 | 0.96 | 63 | 4.17 | 0.57 | 0.69 | 1 | |
| | 4800 | 77.2 | 2.51 | 0.56 | 0.67 | 0.99 | 73.5 | 3 | 0.58 | 0.7 | 1 | 69.7 | 3.55 | 0.59 | 0.78 | 1 | 65.2 | 4.16 | 0.62 | 0.87 | 1 | |
| 71°F | 3200 | 75.1 | 2.54 | 0.41 | 0.49 | 0.57 | 71.8 | 3.02 | 0.41 | 0.5 | 0.58 | 68.2 | 3.56 | 0.42 | 0.51 | 0.59 | 64.3 | 4.16 | 0.43 | 0.52 | 0.78 | |
| | 4000 | 79.2 | 2.5 | 0.43 | 0.52 | 0.61 | 75.7 | 2.99 | 0.44 | 0.53 | 0.63 | 71.9 | 3.54 | 0.44 | 0.55 | 0.65 | 67.6 | 4.14 | 0.46 | 0.57 | 0.86 | |
| | 4800 | 82.1 | 2.46 | 0.44 | 0.56 | 0.66 | 78.5 | 2.96 | 0.47 | 0.57 | 0.68 | 74.6 | 3.51 | 0.47 | 0.59 | 0.74 | 69.9 | 4.12 | 0.49 | 0.61 | 0.94 | |

EL180KCSDT + EL240KASD - 2 COMPRESSORS - PART LOAD / PART LOAD

| Entering Wet Bulb Temperature | Total Air Volume | Outdoor Air Temperature Entering Outdoor Coil | | | | | | | | | | | | | | | | | | | | |
|-------------------------------|------------------|---|-------------------|-------------------------------|------|-------|-----------------|-------------------|-------------------------------|------|-------|-----------------|-------------------|-------------------------------|------|-------|-----------------|-------------------|-------------------------------|------|-----|--|
| | | 85°F | | | | | | 95°F | | | | | 105°F | | | | | 115°F | | | | |
| | | Total Cool Cap. | Comp. Motor Input | Sensible To Total Ratio (S/T) | | | Total Cool Cap. | Comp. Motor Input | Sensible To Total Ratio (S/T) | | | Total Cool Cap. | Comp. Motor Input | Sensible To Total Ratio (S/T) | | | Total Cool Cap. | Comp. Motor Input | Sensible To Total Ratio (S/T) | | | |
| | | | | Dry Bulb | | | | | Dry Bulb | | | | | Dry Bulb | | | | | Dry Bulb | | | |
| cfm | kBtuh | kW | 75°F | 80°F | 85°F | kBtuh | kW | 75°F | 80°F | 85°F | kBtuh | kW | 75°F | 80°F | 85°F | kBtuh | kW | 75°F | 80°F | 85°F | | |
| 63°F | 3600 | 129.6 | 7.19 | 0.65 | 0.9 | 1 | 121.5 | 8.38 | 0.68 | 1 | 1 | 112.6 | 9.75 | 0.7 | 1 | 1 | 104 | 11.21 | 0.79 | 1 | 1 | |
| | 4500 | 136.1 | 7.14 | 0.71 | 1 | 1 | 128.6 | 8.32 | 0.79 | 1 | 1 | 120.5 | 9.65 | 0.96 | 1 | 1 | 112.7 | 11.16 | 1 | 1 | 1 | |
| | 5400 | 144 | 7.09 | 0.95 | 1 | 1 | 136.3 | 8.26 | 1 | 1 | 1 | 127.4 | 9.6 | 1 | 1 | 1 | 119.3 | 11.08 | 1 | 1 | 1 | |
| 67°F | 3600 | 139.6 | 7.12 | 0.54 | 0.64 | 0.78 | 131.1 | 8.3 | 0.55 | 0.66 | 0.91 | 121.3 | 9.64 | 0.57 | 0.69 | 1 | 112.1 | 11.17 | 0.59 | 0.72 | 1 | |
| | 4500 | 146.3 | 7.07 | 0.58 | 0.7 | 1 | 137.2 | 8.26 | 0.6 | 0.73 | 1 | 126.5 | 9.61 | 0.62 | 0.89 | 1 | 116.9 | 11.11 | 0.65 | 1 | 1 | |
| | 5400 | 151.1 | 7.03 | 0.62 | 0.88 | 1 | 141.2 | 8.23 | 0.65 | 1 | 1 | 130.2 | 9.58 | 0.68 | 1 | 1 | 120.1 | 11.08 | 0.71 | 1 | 1 | |
| 71°F | 3600 | 149.7 | 7.04 | 0.43 | 0.53 | 0.62 | 140.6 | 8.23 | 0.44 | 0.54 | 0.64 | 130.8 | 9.58 | 0.46 | 0.56 | 0.67 | 120.9 | 11.07 | 0.47 | 0.59 | 0.9 | |
| | 4500 | 157 | 6.99 | 0.46 | 0.57 | 0.68 | 147.3 | 8.18 | 0.48 | 0.59 | 0.71 | 136.4 | 9.54 | 0.49 | 0.62 | 0.8 | 126.5 | 11.03 | 0.51 | 0.65 | 1 | |
| | 5400 | 162.1 | 6.95 | 0.49 | 0.62 | 0.82 | 152.2 | 8.15 | 0.51 | 0.65 | 0.98 | 140.7 | 9.51 | 0.53 | 0.68 | 1 | 129.2 | 11.02 | 0.56 | 0.72 | 1 | |

EL180KCSDT + EL240KASD - 2 COMPRESSORS - FULL LOAD

| Entering Wet Bulb Temperature | Total Air Volume | Outdoor Air Temperature Entering Outdoor Coil | | | | | | | | | | | | | | | | | | | | |
|-------------------------------|------------------|---|-------------------|-------------------------------|------|-------|-----------------|-------------------|-------------------------------|------|-------|-----------------|-------------------|-------------------------------|------|-------|-----------------|-------------------|-------------------------------|------|------|--|
| | | 85°F | | | | | | 95°F | | | | | 105°F | | | | | 115°F | | | | |
| | | Total Cool Cap. | Comp. Motor Input | Sensible To Total Ratio (S/T) | | | Total Cool Cap. | Comp. Motor Input | Sensible To Total Ratio (S/T) | | | Total Cool Cap. | Comp. Motor Input | Sensible To Total Ratio (S/T) | | | Total Cool Cap. | Comp. Motor Input | Sensible To Total Ratio (S/T) | | | |
| | | | | Dry Bulb | | | | | Dry Bulb | | | | | Dry Bulb | | | | | Dry Bulb | | | |
| cfm | kBtuh | kW | 75°F | 80°F | 85°F | kBtuh | kW | 75°F | 80°F | 85°F | kBtuh | kW | 75°F | 80°F | 85°F | kBtuh | kW | 75°F | 80°F | 85°F | | |
| 63°F | 4800 | 189.1 | 11.37 | 0.63 | 0.8 | 1 | 179.4 | 12.76 | 0.65 | 0.86 | 1 | 167.7 | 14.34 | 0.67 | 0.95 | 1 | 156.6 | 16.11 | 0.7 | 1 | 1 | |
| | 6000 | 198.8 | 11.47 | 0.68 | 1 | 1 | 187.8 | 12.85 | 0.73 | 1 | 1 | 175.3 | 14.41 | 0.8 | 1 | 1 | 164.7 | 16.2 | 0.89 | 1 | 1 | |
| | 7200 | 205.6 | 11.55 | 0.81 | 1 | 1 | 194.7 | 12.93 | 0.89 | 1 | 1 | 185 | 14.52 | 0.99 | 1 | 1 | 173.3 | 16.29 | 1 | 1 | 1 | |
| 67°F | 4800 | 202.5 | 11.52 | 0.52 | 0.61 | 0.73 | 191.9 | 12.9 | 0.53 | 0.63 | 0.79 | 180.6 | 14.47 | 0.55 | 0.65 | 0.88 | 167.4 | 16.22 | 0.57 | 0.68 | 0.99 | |
| | 6000 | 212.6 | 11.63 | 0.56 | 0.67 | 0.92 | 199.8 | 12.99 | 0.58 | 0.69 | 1 | 187.6 | 14.56 | 0.6 | 0.76 | 1 | 174.4 | 16.3 | 0.62 | 0.86 | 1 | |
| | 7200 | 219.7 | 11.7 | 0.6 | 0.77 | 1 | 206.1 | 13.06 | 0.62 | 0.86 | 1 | 193.3 | 14.62 | 0.64 | 0.95 | 1 | 179.1 | 16.38 | 0.67 | 1 | 1 | |
| 71°F | 4800 | 215.6 | 11.66 | 0.43 | 0.51 | 0.6 | 203.3 | 13.02 | 0.44 | 0.53 | 0.62 | 191.5 | 14.6 | 0.44 | 0.54 | 0.64 | 178.9 | 16.37 | 0.46 | 0.56 | 0.83 | |
| | 6000 | 226.4 | 11.79 | 0.45 | 0.56 | 0.65 | 212.6 | 13.14 | 0.46 | 0.57 | 0.68 | 200.1 | 14.7 | 0.48 | 0.59 | 0.72 | 186.5 | 16.46 | 0.49 | 0.62 | 0.92 | |
| | 7200 | 232.7 | 11.87 | 0.48 | 0.6 | 0.74 | 220.2 | 13.24 | 0.49 | 0.61 | 0.82 | 206.4 | 14.79 | 0.51 | 0.64 | 0.92 | 192.3 | 16.53 | 0.53 | 0.67 | 1 | |

RATINGS

ONE OUTDOOR UNIT + ONE INDOOR UNIT

NOTE - For Temperatures and Capacities not shown in tables, see bulletin - Cooling Unit Rating Table Correction Factor Data in Miscellaneous Engineering Data section.

EL240KCSDT + EL240KASD - 1 COMPRESSOR - PART LOAD

| Entering Wet Bulb Temperature | Total Air Volume | Outdoor Air Temperature Entering Outdoor Coil | | | | | | | | | | | | | | | | | | | | |
|-------------------------------|------------------|---|-------------------|-------------------------------|------|-------|-----------------|-------------------|-------------------------------|------|-------|-----------------|-------------------|-------------------------------|------|-------|-----------------|-------------------|-------------------------------|------|------|--|
| | | 65°F | | | | | | 75°F | | | | | 85°F | | | | | 95°F | | | | |
| | | Total Cool Cap. | Comp. Motor Input | Sensible To Total Ratio (S/T) | | | Total Cool Cap. | Comp. Motor Input | Sensible To Total Ratio (S/T) | | | Total Cool Cap. | Comp. Motor Input | Sensible To Total Ratio (S/T) | | | Total Cool Cap. | Comp. Motor Input | Sensible To Total Ratio (S/T) | | | |
| | | | | Dry Bulb | | | | | Dry Bulb | | | | | Dry Bulb | | | | | Dry Bulb | | | |
| cfm | kBtuh | kW | 75°F | 80°F | 85°F | kBtuh | kW | 75°F | 80°F | 85°F | kBtuh | kW | 75°F | 80°F | 85°F | kBtuh | kW | 75°F | 80°F | 85°F | | |
| 63°F | 4240 | 82.1 | 3.31 | 0.68 | 0.78 | 1 | 78.8 | 3.86 | 0.69 | 0.82 | 1 | 75 | 4.48 | 0.71 | 0.88 | 1 | 70.7 | 5.18 | 0.73 | 0.95 | 1 | |
| | 5300 | 86.3 | 3.3 | 0.73 | 0.95 | 1 | 82.8 | 3.85 | 0.74 | 1 | 1 | 78.6 | 4.47 | 0.77 | 1 | 1 | 73.6 | 5.17 | 0.81 | 1 | 1 | |
| | 6360 | 89.3 | 3.29 | 0.79 | 1 | 1 | 85.7 | 3.84 | 0.84 | 1 | 1 | 82.1 | 4.46 | 0.91 | 1 | 1 | 77.7 | 5.15 | 0.98 | 1 | 1 | |
| 67°F | 4240 | 87.7 | 3.29 | 0.56 | 0.66 | 0.76 | 84.2 | 3.84 | 0.57 | 0.67 | 0.77 | 80.4 | 4.46 | 0.58 | 0.69 | 0.81 | 75.9 | 5.16 | 0.6 | 0.71 | 0.95 | |
| | 5300 | 91.9 | 3.29 | 0.6 | 0.71 | 0.9 | 88.4 | 3.83 | 0.61 | 0.73 | 0.95 | 84.3 | 4.45 | 0.63 | 0.75 | 1 | 79 | 5.15 | 0.65 | 0.78 | 1 | |
| | 6360 | 94.9 | 3.29 | 0.64 | 0.77 | 1 | 91.3 | 3.83 | 0.66 | 0.8 | 1 | 87 | 4.44 | 0.67 | 0.86 | 1 | 81.5 | 5.14 | 0.7 | 0.96 | 1 | |
| 71°F | 4240 | 92.9 | 3.29 | 0.46 | 0.55 | 0.65 | 89.6 | 3.83 | 0.47 | 0.56 | 0.66 | 85.7 | 4.45 | 0.47 | 0.57 | 0.67 | 80.8 | 5.15 | 0.48 | 0.59 | 0.79 | |
| | 5300 | 97.4 | 3.28 | 0.47 | 0.6 | 0.7 | 93.9 | 3.82 | 0.5 | 0.61 | 0.72 | 89.2 | 4.44 | 0.52 | 0.62 | 0.73 | 84.4 | 5.14 | 0.52 | 0.64 | 0.88 | |
| | 6360 | 100.5 | 3.28 | 0.52 | 0.64 | 0.76 | 96.9 | 3.82 | 0.53 | 0.65 | 0.78 | 92.1 | 4.43 | 0.54 | 0.67 | 0.83 | 86.9 | 5.13 | 0.55 | 0.7 | 0.96 | |

EL240KCSDT + EL240KASD - 2 COMPRESSORS - PART LOAD / PART LOAD

| Entering Wet Bulb Temperature | Total Air Volume | Outdoor Air Temperature Entering Outdoor Coil | | | | | | | | | | | | | | | | | | | | |
|-------------------------------|------------------|---|-------------------|-------------------------------|------|-------|-----------------|-------------------|-------------------------------|------|-------|-----------------|-------------------|-------------------------------|------|-------|-----------------|-------------------|-------------------------------|------|------|--|
| | | 85°F | | | | | | 95°F | | | | | 105°F | | | | | 115°F | | | | |
| | | Total Cool Cap. | Comp. Motor Input | Sensible To Total Ratio (S/T) | | | Total Cool Cap. | Comp. Motor Input | Sensible To Total Ratio (S/T) | | | Total Cool Cap. | Comp. Motor Input | Sensible To Total Ratio (S/T) | | | Total Cool Cap. | Comp. Motor Input | Sensible To Total Ratio (S/T) | | | |
| | | | | Dry Bulb | | | | | Dry Bulb | | | | | Dry Bulb | | | | | Dry Bulb | | | |
| cfm | kBtuh | kW | 75°F | 80°F | 85°F | kBtuh | kW | 75°F | 80°F | 85°F | kBtuh | kW | 75°F | 80°F | 85°F | kBtuh | kW | 75°F | 80°F | 85°F | | |
| 63°F | 4800 | 162.6 | 8.79 | 0.73 | 0.97 | 1 | 152.1 | 10.17 | 0.76 | 1 | 1 | 142.7 | 11.7 | 0.79 | 1 | 1 | 132.2 | 13.42 | 0.86 | 1 | 1 | |
| | 6000 | 170.3 | 8.77 | 0.8 | 1 | 1 | 160.9 | 10.14 | 0.87 | 1 | 1 | 151.8 | 11.67 | 1 | 1 | 1 | 141.9 | 13.39 | 1 | 1 | 1 | |
| | 7200 | 179.4 | 8.75 | 1 | 1 | 1 | 170.5 | 10.11 | 1 | 1 | 1 | 159.7 | 11.65 | 1 | 1 | 1 | 149.4 | 13.37 | 1 | 1 | 1 | |
| 67°F | 4800 | 174.1 | 8.76 | 0.61 | 0.72 | 0.87 | 163.5 | 10.13 | 0.62 | 0.74 | 0.98 | 152.5 | 11.67 | 0.65 | 0.78 | 1 | 140.8 | 13.39 | 0.67 | 0.81 | 1 | |
| | 6000 | 181.7 | 8.74 | 0.66 | 0.79 | 1 | 170.7 | 10.11 | 0.68 | 0.82 | 1 | 158.5 | 11.65 | 0.7 | 0.96 | 1 | 146.4 | 13.37 | 0.74 | 1 | 1 | |
| | 7200 | 186.8 | 8.73 | 0.72 | 0.97 | 1 | 175 | 10.1 | 0.73 | 1 | 1 | 162.8 | 11.64 | 0.76 | 1 | 1 | 150.1 | 13.36 | 0.8 | 1 | 1 | |
| 71°F | 4800 | 185.2 | 8.73 | 0.48 | 0.6 | 0.7 | 174.4 | 10.1 | 0.5 | 0.61 | 0.73 | 163.2 | 11.64 | 0.51 | 0.64 | 0.76 | 152.1 | 13.36 | 0.53 | 0.67 | 0.92 | |
| | 6000 | 192 | 8.72 | 0.51 | 0.65 | 0.78 | 181.4 | 10.09 | 0.53 | 0.68 | 0.81 | 169.8 | 11.62 | 0.55 | 0.7 | 0.91 | 157.4 | 13.34 | 0.58 | 0.74 | 1 | |
| | 7200 | 197.2 | 8.71 | 0.54 | 0.71 | 0.94 | 186.2 | 10.08 | 0.58 | 0.73 | 1 | 173.9 | 11.61 | 0.6 | 0.76 | 1 | 161.4 | 13.33 | 0.61 | 0.8 | 1 | |

EL240KCSDT + EL240KASD - 2 COMPRESSORS - FULL LOAD

| Entering Wet Bulb Temperature | Total Air Volume | Outdoor Air Temperature Entering Outdoor Coil | | | | | | | | | | | | | | | | | | | | |
|-------------------------------|------------------|---|-------------------|-------------------------------|------|-------|-----------------|-------------------|-------------------------------|------|-------|-----------------|-------------------|-------------------------------|------|-------|-----------------|-------------------|-------------------------------|------|------|--|
| | | 85°F | | | | | | 95°F | | | | | 105°F | | | | | 115°F | | | | |
| | | Total Cool Cap. | Comp. Motor Input | Sensible To Total Ratio (S/T) | | | Total Cool Cap. | Comp. Motor Input | Sensible To Total Ratio (S/T) | | | Total Cool Cap. | Comp. Motor Input | Sensible To Total Ratio (S/T) | | | Total Cool Cap. | Comp. Motor Input | Sensible To Total Ratio (S/T) | | | |
| | | | | Dry Bulb | | | | | Dry Bulb | | | | | Dry Bulb | | | | | Dry Bulb | | | |
| cfm | kBtuh | kW | 75°F | 80°F | 85°F | kBtuh | kW | 75°F | 80°F | 85°F | kBtuh | kW | 75°F | 80°F | 85°F | kBtuh | kW | 75°F | 80°F | 85°F | | |
| 63°F | 6400 | 241.8 | 14.33 | 0.7 | 0.87 | 1 | 230.2 | 15.89 | 0.72 | 0.9 | 1 | 217.3 | 17.68 | 0.74 | 0.97 | 1 | 206.4 | 19.74 | 0.76 | 1 | 1 | |
| | 8000 | 251.2 | 14.48 | 0.76 | 1 | 1 | 240.1 | 16.06 | 0.8 | 1 | 1 | 227.7 | 17.85 | 0.84 | 1 | 1 | 215.4 | 19.9 | 0.9 | 1 | 1 | |
| | 9600 | 258.8 | 14.61 | 0.87 | 1 | 1 | 247.2 | 16.17 | 0.93 | 1 | 1 | 236.1 | 17.99 | 0.99 | 1 | 1 | 224.5 | 20.05 | 1 | 1 | 1 | |
| 67°F | 6400 | 255.2 | 14.55 | 0.58 | 0.69 | 0.81 | 244.7 | 16.14 | 0.59 | 0.7 | 0.86 | 232.8 | 17.94 | 0.6 | 0.72 | 0.92 | 219.6 | 19.97 | 0.62 | 0.74 | 0.99 | |
| | 8000 | 265.7 | 14.71 | 0.62 | 0.74 | 0.99 | 253 | 16.26 | 0.63 | 0.77 | 1 | 240.3 | 18.06 | 0.65 | 0.83 | 1 | 226.8 | 20.09 | 0.67 | 0.88 | 1 | |
| | 9600 | 273.3 | 14.83 | 0.67 | 0.85 | 1 | 260.5 | 16.38 | 0.68 | 0.9 | 1 | 247.5 | 18.17 | 0.7 | 0.97 | 1 | 233.1 | 20.19 | 0.73 | 1 | 1 | |
| 71°F | 6400 | 270.5 | 14.78 | 0.46 | 0.58 | 0.67 | 258 | 16.35 | 0.47 | 0.58 | 0.69 | 245.3 | 18.14 | 0.49 | 0.6 | 0.71 | 232.2 | 20.18 | 0.49 | 0.61 | 0.84 | |
| | 8000 | 281.1 | 14.95 | 0.5 | 0.61 | 0.73 | 268.2 | 16.5 | 0.51 | 0.64 | 0.75 | 255.2 | 18.31 | 0.52 | 0.65 | 0.78 | 240.8 | 20.32 | 0.54 | 0.67 | 0.93 | |
| | 9600 | 288.3 | 15.06 | 0.54 | 0.67 | 0.83 | 275.4 | 16.62 | 0.56 | 0.69 | 0.89 | 261.4 | 18.4 | 0.57 | 0.71 | 0.96 | 245.2 | 20.4 | 0.59 | 0.73 | 1 | |

RATINGS

ONE OUTDOOR UNIT + TWO INDOOR UNITS

NOTE - For Temperatures and Capacities not shown in tables, see bulletin - Cooling Unit Rating Table Correction Factor Data in Miscellaneous Engineering Data section.

EL180KCSDT - (2) EL090KASD - 1 COMPRESSOR - PART LOAD

| Entering Wet Bulb Temperature | Total Air Volume | Outdoor Air Temperature Entering Outdoor Coil | | | | | | | | | | | | | | | | | | | |
|-------------------------------|------------------|---|-------------------|-------------------------------|------|-------|-----------------|-------------------|-------------------------------|------|-------|-----------------|-------------------|-------------------------------|------|-------|-----------------|-------------------|-------------------------------|------|------|
| | | 65°F | | | | | 75°F | | | | | 85°F | | | | | 95°F | | | | |
| | | Total Cool Cap. | Comp. Motor Input | Sensible To Total Ratio (S/T) | | | Total Cool Cap. | Comp. Motor Input | Sensible To Total Ratio (S/T) | | | Total Cool Cap. | Comp. Motor Input | Sensible To Total Ratio (S/T) | | | Total Cool Cap. | Comp. Motor Input | Sensible To Total Ratio (S/T) | | |
| | | | | Dry Bulb | | | | | Dry Bulb | | | | | Dry Bulb | | | | | Dry Bulb | | |
| cfm | kBtuh | kW | 75°F | 80°F | 85°F | kBtuh | kW | 75°F | 80°F | 85°F | kBtuh | kW | 75°F | 80°F | 85°F | kBtuh | kW | 75°F | 80°F | 85°F | |
| 63°F | 3200 | 64.7 | 2.63 | 0.68 | 0.8 | 0.96 | 61.6 | 3.1 | 0.7 | 0.83 | 0.99 | 58.5 | 3.63 | 0.72 | 0.86 | 1 | 54.5 | 4.23 | 0.74 | 0.91 | 1 |
| | 4000 | 68.6 | 2.6 | 0.73 | 0.89 | 1 | 64.9 | 3.08 | 0.75 | 0.93 | 1 | 61.4 | 3.61 | 0.77 | 0.97 | 1 | 57.6 | 4.21 | 0.81 | 1 | 1 |
| | 4800 | 71.5 | 2.57 | 0.78 | 0.98 | 1 | 67.6 | 3.06 | 0.81 | 1 | 1 | 64.2 | 3.6 | 0.85 | 1 | 1 | 60.7 | 4.19 | 0.89 | 1 | 1 |
| 67°F | 3200 | 69.5 | 2.59 | 0.56 | 0.66 | 0.76 | 66.3 | 3.07 | 0.57 | 0.67 | 0.79 | 62.6 | 3.6 | 0.58 | 0.69 | 0.82 | 59 | 4.2 | 0.59 | 0.71 | 0.89 |
| | 4000 | 73.5 | 2.55 | 0.59 | 0.71 | 0.85 | 69.8 | 3.04 | 0.6 | 0.73 | 0.88 | 66 | 3.58 | 0.61 | 0.75 | 0.93 | 62.1 | 4.18 | 0.63 | 0.77 | 0.98 |
| | 4800 | 76 | 2.53 | 0.62 | 0.76 | 0.94 | 72.3 | 3.02 | 0.63 | 0.78 | 0.98 | 68.7 | 3.56 | 0.65 | 0.81 | 1 | 63.9 | 4.17 | 0.67 | 0.86 | 1 |
| 71°F | 3200 | 74.1 | 2.54 | 0.44 | 0.54 | 0.64 | 70.5 | 3.03 | 0.45 | 0.55 | 0.65 | 67 | 3.57 | 0.46 | 0.56 | 0.67 | 63 | 4.17 | 0.46 | 0.58 | 0.74 |
| | 4000 | 78 | 2.51 | 0.46 | 0.58 | 0.69 | 74.3 | 3 | 0.47 | 0.59 | 0.7 | 70.4 | 3.55 | 0.47 | 0.6 | 0.73 | 66.3 | 4.15 | 0.49 | 0.62 | 0.8 |
| | 4800 | 80.8 | 2.48 | 0.48 | 0.61 | 0.74 | 77.4 | 2.97 | 0.49 | 0.62 | 0.76 | 73.2 | 3.53 | 0.49 | 0.64 | 0.79 | 68.6 | 4.13 | 0.51 | 0.66 | 0.87 |

EL180KCSDT - (2) EL090KASD - 2 COMPRESSORS - PART LOAD / PART LOAD

| Entering Wet Bulb Temperature | Total Air Volume | Outdoor Air Temperature Entering Outdoor Coil | | | | | | | | | | | | | | | | | | | |
|-------------------------------|------------------|---|-------------------|-------------------------------|------|-------|-----------------|-------------------|-------------------------------|------|-------|-----------------|-------------------|-------------------------------|------|-------|-----------------|-------------------|-------------------------------|------|------|
| | | 85°F | | | | | 95°F | | | | | 105°F | | | | | 115°F | | | | |
| | | Total Cool Cap. | Comp. Motor Input | Sensible To Total Ratio (S/T) | | | Total Cool Cap. | Comp. Motor Input | Sensible To Total Ratio (S/T) | | | Total Cool Cap. | Comp. Motor Input | Sensible To Total Ratio (S/T) | | | Total Cool Cap. | Comp. Motor Input | Sensible To Total Ratio (S/T) | | |
| | | | | Dry Bulb | | | | | Dry Bulb | | | | | Dry Bulb | | | | | Dry Bulb | | |
| cfm | kBtuh | kW | 75°F | 80°F | 85°F | kBtuh | kW | 75°F | 80°F | 85°F | kBtuh | kW | 75°F | 80°F | 85°F | kBtuh | kW | 75°F | 80°F | 85°F | |
| 63°F | 3600 | 127.5 | 7.2 | 0.75 | 0.92 | 1 | 119.7 | 8.41 | 0.78 | 0.96 | 1 | 110.8 | 9.77 | 0.81 | 1 | 1 | 102.3 | 11.22 | 0.85 | 1 | 1 |
| | 4500 | 134.4 | 7.15 | 0.82 | 1 | 1 | 126.6 | 8.33 | 0.85 | 1 | 1 | 118.7 | 9.67 | 0.91 | 1 | 1 | 110.5 | 11.19 | 0.97 | 1 | 1 |
| | 5400 | 141.8 | 7.1 | 0.9 | 1 | 1 | 134.1 | 8.28 | 0.96 | 1 | 1 | 125.4 | 9.61 | 1 | 1 | 1 | 117.1 | 11.11 | 1 | 1 | 1 |
| 67°F | 3600 | 137.4 | 7.13 | 0.6 | 0.73 | 0.87 | 129.2 | 8.31 | 0.62 | 0.75 | 0.91 | 119.8 | 9.66 | 0.64 | 0.78 | 0.97 | 110 | 11.19 | 0.66 | 0.82 | 1 |
| | 4500 | 144.5 | 7.08 | 0.65 | 0.79 | 0.99 | 134.9 | 8.27 | 0.67 | 0.83 | 1 | 124.9 | 9.62 | 0.69 | 0.88 | 1 | 115.5 | 11.12 | 0.72 | 0.94 | 1 |
| | 5400 | 149.2 | 7.04 | 0.69 | 0.87 | 1 | 138.7 | 8.25 | 0.71 | 0.93 | 1 | 128.2 | 9.59 | 0.74 | 0.99 | 1 | 118 | 11.09 | 0.78 | 1 | 1 |
| 71°F | 3600 | 147.1 | 7.06 | 0.47 | 0.59 | 0.71 | 137.8 | 8.25 | 0.48 | 0.61 | 0.73 | 128.7 | 9.59 | 0.49 | 0.63 | 0.76 | 118.6 | 11.09 | 0.5 | 0.65 | 0.84 |
| | 4500 | 154.1 | 7.01 | 0.49 | 0.64 | 0.77 | 144.4 | 8.2 | 0.51 | 0.66 | 0.8 | 134.6 | 9.56 | 0.52 | 0.68 | 0.84 | 124 | 11.05 | 0.54 | 0.71 | 0.93 |
| | 5400 | 159.1 | 6.97 | 0.52 | 0.68 | 0.85 | 149.1 | 8.17 | 0.54 | 0.71 | 0.89 | 138.9 | 9.53 | 0.55 | 0.74 | 0.96 | 127.7 | 11.03 | 0.57 | 0.77 | 1 |

EL180KCSDT - (2) EL090KASD - 2 COMPRESSORS - FULL LOAD

| Entering Wet Bulb Temperature | Total Air Volume | Outdoor Air Temperature Entering Outdoor Coil | | | | | | | | | | | | | | | | | | | |
|-------------------------------|------------------|---|-------------------|-------------------------------|------|-------|-----------------|-------------------|-------------------------------|------|-------|-----------------|-------------------|-------------------------------|------|-------|-----------------|-------------------|-------------------------------|------|------|
| | | 85°F | | | | | 95°F | | | | | 105°F | | | | | 115°F | | | | |
| | | Total Cool Cap. | Comp. Motor Input | Sensible To Total Ratio (S/T) | | | Total Cool Cap. | Comp. Motor Input | Sensible To Total Ratio (S/T) | | | Total Cool Cap. | Comp. Motor Input | Sensible To Total Ratio (S/T) | | | Total Cool Cap. | Comp. Motor Input | Sensible To Total Ratio (S/T) | | |
| | | | | Dry Bulb | | | | | Dry Bulb | | | | | Dry Bulb | | | | | Dry Bulb | | |
| cfm | kBtuh | kW | 75°F | 80°F | 85°F | kBtuh | kW | 75°F | 80°F | 85°F | kBtuh | kW | 75°F | 80°F | 85°F | kBtuh | kW | 75°F | 80°F | 85°F | |
| 63°F | 4800 | 185.4 | 11.32 | 0.73 | 0.87 | 1 | 174.4 | 12.71 | 0.75 | 0.9 | 1 | 164.8 | 14.29 | 0.77 | 0.93 | 1 | 153.2 | 16.07 | 0.8 | 0.98 | 1 |
| | 6000 | 194.5 | 11.42 | 0.78 | 0.96 | 1 | 183.6 | 12.81 | 0.81 | 1 | 1 | 172.8 | 14.38 | 0.84 | 1 | 1 | 161.4 | 16.16 | 0.89 | 1 | 1 |
| | 7200 | 202.2 | 11.51 | 0.85 | 1 | 1 | 190.9 | 12.89 | 0.88 | 1 | 1 | 180.7 | 14.47 | 0.93 | 1 | 1 | 170.9 | 16.26 | 0.97 | 1 | 1 |
| 67°F | 4800 | 197.7 | 11.46 | 0.59 | 0.71 | 0.83 | 187.9 | 12.85 | 0.6 | 0.72 | 0.86 | 176 | 14.42 | 0.62 | 0.75 | 0.9 | 164.6 | 16.19 | 0.64 | 0.77 | 0.95 |
| | 6000 | 207.9 | 11.58 | 0.63 | 0.76 | 0.92 | 196 | 12.94 | 0.64 | 0.79 | 0.96 | 183.9 | 14.51 | 0.66 | 0.82 | 1 | 171.1 | 16.27 | 0.69 | 0.86 | 1 |
| | 7200 | 214.3 | 11.65 | 0.67 | 0.83 | 1 | 202.6 | 13.02 | 0.68 | 0.86 | 1 | 190.2 | 14.59 | 0.71 | 0.9 | 1 | 176 | 16.33 | 0.74 | 0.95 | 1 |
| 71°F | 4800 | 210.6 | 11.6 | 0.47 | 0.58 | 0.68 | 199.3 | 12.98 | 0.48 | 0.59 | 0.7 | 187.8 | 14.56 | 0.48 | 0.61 | 0.73 | 175 | 16.31 | 0.49 | 0.62 | 0.78 |
| | 6000 | 220.7 | 11.71 | 0.49 | 0.62 | 0.74 | 209.4 | 13.09 | 0.5 | 0.63 | 0.77 | 196.3 | 14.66 | 0.51 | 0.65 | 0.8 | 182.7 | 16.41 | 0.52 | 0.68 | 0.87 |
| | 7200 | 228.4 | 11.81 | 0.51 | 0.66 | 0.8 | 215.7 | 13.18 | 0.52 | 0.68 | 0.84 | 202.1 | 14.72 | 0.54 | 0.7 | 0.88 | 188.3 | 16.48 | 0.55 | 0.73 | 0.94 |

RATINGS

ONE OUTDOOR UNIT + TWO INDOOR UNITS

NOTE - For Temperatures and Capacities not shown in tables, see bulletin - Cooling Unit Rating Table Correction Factor Data in Miscellaneous Engineering Data section.

EL240KCSDT - (2) EL120KASD - 1 COMPRESSOR - PART LOAD

| Entering Wet Bulb Temperature | Total Air Volume | Outdoor Air Temperature Entering Outdoor Coil | | | | | | | | | | | | | | | | | | | | |
|-------------------------------|------------------|---|-------------------|-------------------------------|------|-------|-----------------|-------------------|-------------------------------|------|-------|-----------------|-------------------|-------------------------------|------|-------|-----------------|-------------------|-------------------------------|------|------|--|
| | | 65°F | | | | | | 75°F | | | | | 85°F | | | | | 95°F | | | | |
| | | Total Cool Cap. | Comp. Motor Input | Sensible To Total Ratio (S/T) | | | Total Cool Cap. | Comp. Motor Input | Sensible To Total Ratio (S/T) | | | Total Cool Cap. | Comp. Motor Input | Sensible To Total Ratio (S/T) | | | Total Cool Cap. | Comp. Motor Input | Sensible To Total Ratio (S/T) | | | |
| | | | | Dry Bulb | | | | | Dry Bulb | | | | | Dry Bulb | | | | | Dry Bulb | | | |
| cfm | kBtuh | kW | 75°F | 80°F | 85°F | kBtuh | kW | 75°F | 80°F | 85°F | kBtuh | kW | 75°F | 80°F | 85°F | kBtuh | kW | 75°F | 80°F | 85°F | | |
| 63°F | 4240 | 81.6 | 3.38 | 0.68 | 0.81 | 0.99 | 78.5 | 3.94 | 0.7 | 0.84 | 1 | 74.2 | 4.58 | 0.71 | 0.87 | 1 | 69.6 | 5.3 | 0.73 | 0.92 | 1 | |
| | 5300 | 86.1 | 3.37 | 0.73 | 0.92 | 1 | 82.2 | 3.93 | 0.74 | 0.95 | 1 | 78 | 4.57 | 0.77 | 1 | 1 | 73.2 | 5.29 | 0.8 | 1 | 1 | |
| | 6360 | 89.5 | 3.37 | 0.79 | 1 | 1 | 85.5 | 3.93 | 0.83 | 1 | 1 | 82.1 | 4.56 | 0.85 | 1 | 1 | 77.6 | 5.27 | 0.9 | 1 | 1 | |
| 67°F | 4240 | 87.4 | 3.37 | 0.55 | 0.66 | 0.77 | 83.6 | 3.93 | 0.56 | 0.67 | 0.79 | 79.6 | 4.57 | 0.57 | 0.69 | 0.82 | 75 | 5.28 | 0.58 | 0.71 | 0.91 | |
| | 5300 | 91.2 | 3.36 | 0.59 | 0.71 | 0.87 | 87.7 | 3.92 | 0.6 | 0.72 | 0.9 | 83.3 | 4.55 | 0.62 | 0.74 | 0.95 | 78.4 | 5.27 | 0.63 | 0.77 | 1 | |
| | 6360 | 94.4 | 3.36 | 0.62 | 0.77 | 0.98 | 90.5 | 3.91 | 0.63 | 0.79 | 1 | 86 | 4.55 | 0.65 | 0.82 | 1 | 80.8 | 5.26 | 0.67 | 0.87 | 1 | |
| 71°F | 4240 | 92.3 | 3.36 | 0.44 | 0.54 | 0.64 | 88.9 | 3.92 | 0.44 | 0.55 | 0.65 | 84.8 | 4.55 | 0.44 | 0.56 | 0.67 | 80.1 | 5.26 | 0.45 | 0.57 | 0.75 | |
| | 5300 | 96.8 | 3.36 | 0.46 | 0.58 | 0.69 | 93.1 | 3.91 | 0.46 | 0.59 | 0.71 | 88.8 | 4.54 | 0.47 | 0.6 | 0.73 | 84 | 5.25 | 0.48 | 0.62 | 0.82 | |
| | 6360 | 100.1 | 3.36 | 0.47 | 0.62 | 0.75 | 96.4 | 3.91 | 0.49 | 0.63 | 0.76 | 92 | 4.54 | 0.49 | 0.64 | 0.8 | 86.3 | 5.25 | 0.5 | 0.66 | 0.89 | |

EL240KCSDT - (2) EL120KASD - 2 COMPRESSORS - PART LOAD / PART LOAD

| Entering Wet Bulb Temperature | Total Air Volume | Outdoor Air Temperature Entering Outdoor Coil | | | | | | | | | | | | | | | | | | | | |
|-------------------------------|------------------|---|-------------------|-------------------------------|------|-------|-----------------|-------------------|-------------------------------|------|-------|-----------------|-------------------|-------------------------------|------|-------|-----------------|-------------------|-------------------------------|------|------|--|
| | | 85°F | | | | | | 95°F | | | | | 105°F | | | | | 115°F | | | | |
| | | Total Cool Cap. | Comp. Motor Input | Sensible To Total Ratio (S/T) | | | Total Cool Cap. | Comp. Motor Input | Sensible To Total Ratio (S/T) | | | Total Cool Cap. | Comp. Motor Input | Sensible To Total Ratio (S/T) | | | Total Cool Cap. | Comp. Motor Input | Sensible To Total Ratio (S/T) | | | |
| | | | | Dry Bulb | | | | | Dry Bulb | | | | | Dry Bulb | | | | | Dry Bulb | | | |
| cfm | kBtuh | kW | 75°F | 80°F | 85°F | kBtuh | kW | 75°F | 80°F | 85°F | kBtuh | kW | 75°F | 80°F | 85°F | kBtuh | kW | 75°F | 80°F | 85°F | | |
| 63°F | 4800 | 163.2 | 8.97 | 0.74 | 0.93 | 1 | 154 | 10.37 | 0.77 | 0.98 | 1 | 143 | 11.95 | 0.8 | 1 | 1 | 133.7 | 13.7 | 0.84 | 1 | 1 | |
| | 6000 | 171 | 8.94 | 0.81 | 1 | 1 | 162.9 | 10.34 | 0.85 | 1 | 1 | 153.2 | 11.92 | 0.92 | 1 | 1 | 143.5 | 13.67 | 1 | 1 | 1 | |
| | 7200 | 180.6 | 8.92 | 0.91 | 1 | 1 | 171.6 | 10.32 | 0.97 | 1 | 1 | 162.1 | 11.89 | 1 | 1 | 1 | 150.6 | 13.64 | 1 | 1 | 1 | |
| 67°F | 4800 | 175.3 | 8.93 | 0.59 | 0.72 | 0.87 | 164.5 | 10.33 | 0.61 | 0.75 | 0.92 | 153.5 | 11.91 | 0.63 | 0.77 | 0.99 | 142.2 | 13.67 | 0.65 | 0.81 | 1 | |
| | 6000 | 182.2 | 8.92 | 0.64 | 0.79 | 1 | 172 | 10.31 | 0.66 | 0.82 | 1 | 160.7 | 11.89 | 0.68 | 0.88 | 1 | 147.2 | 13.66 | 0.71 | 0.96 | 1 | |
| | 7200 | 188.4 | 8.9 | 0.69 | 0.88 | 1 | 176.9 | 10.3 | 0.71 | 0.94 | 1 | 164.3 | 11.88 | 0.74 | 1 | 1 | 151.5 | 13.64 | 0.77 | 1 | 1 | |
| 71°F | 4800 | 185.8 | 8.91 | 0.46 | 0.58 | 0.71 | 176.2 | 10.3 | 0.47 | 0.6 | 0.73 | 164.2 | 11.88 | 0.48 | 0.62 | 0.75 | 152.1 | 13.64 | 0.5 | 0.64 | 0.85 | |
| | 6000 | 193.4 | 8.9 | 0.49 | 0.64 | 0.78 | 182.3 | 10.29 | 0.5 | 0.65 | 0.8 | 171.1 | 11.87 | 0.51 | 0.68 | 0.84 | 158.6 | 13.62 | 0.53 | 0.71 | 0.95 | |
| | 7200 | 198.5 | 8.89 | 0.52 | 0.68 | 0.86 | 187.4 | 10.28 | 0.52 | 0.71 | 0.91 | 176 | 11.86 | 0.55 | 0.74 | 0.98 | 162.5 | 13.62 | 0.57 | 0.77 | 1 | |

EL240KCSDT - (2) EL120KASD - 2 COMPRESSORS - FULL LOAD

| Entering Wet Bulb Temperature | Total Air Volume | Outdoor Air Temperature Entering Outdoor Coil | | | | | | | | | | | | | | | | | | | | |
|-------------------------------|------------------|---|-------------------|-------------------------------|------|-------|-----------------|-------------------|-------------------------------|------|-------|-----------------|-------------------|-------------------------------|------|-------|-----------------|-------------------|-------------------------------|------|------|--|
| | | 85°F | | | | | | 95°F | | | | | 105°F | | | | | 115°F | | | | |
| | | Total Cool Cap. | Comp. Motor Input | Sensible To Total Ratio (S/T) | | | Total Cool Cap. | Comp. Motor Input | Sensible To Total Ratio (S/T) | | | Total Cool Cap. | Comp. Motor Input | Sensible To Total Ratio (S/T) | | | Total Cool Cap. | Comp. Motor Input | Sensible To Total Ratio (S/T) | | | |
| | | | | Dry Bulb | | | | | Dry Bulb | | | | | Dry Bulb | | | | | Dry Bulb | | | |
| cfm | kBtuh | kW | 75°F | 80°F | 85°F | kBtuh | kW | 75°F | 80°F | 85°F | kBtuh | kW | 75°F | 80°F | 85°F | kBtuh | kW | 75°F | 80°F | 85°F | | |
| 63°F | 6400 | 239 | 14.46 | 0.73 | 0.87 | 1 | 226.6 | 16.04 | 0.74 | 0.9 | 1 | 216.7 | 17.89 | 0.76 | 0.93 | 1 | 203.1 | 19.94 | 0.78 | 0.97 | 1 | |
| | 8000 | 248.8 | 14.62 | 0.78 | 0.97 | 1 | 237.3 | 16.21 | 0.81 | 1 | 1 | 225.4 | 18.03 | 0.84 | 1 | 1 | 212.6 | 20.1 | 0.87 | 1 | 1 | |
| | 9600 | 258.1 | 14.76 | 0.85 | 1 | 1 | 245.9 | 16.36 | 0.88 | 1 | 1 | 235.7 | 18.2 | 0.92 | 1 | 1 | 223.1 | 20.27 | 0.96 | 1 | 1 | |
| 67°F | 6400 | 252.1 | 14.68 | 0.58 | 0.71 | 0.83 | 241.2 | 16.27 | 0.6 | 0.72 | 0.86 | 228.3 | 18.08 | 0.62 | 0.74 | 0.89 | 216.4 | 20.16 | 0.63 | 0.76 | 0.95 | |
| | 8000 | 263 | 14.85 | 0.63 | 0.76 | 0.93 | 251.8 | 16.44 | 0.64 | 0.78 | 0.97 | 238.2 | 18.24 | 0.66 | 0.81 | 1 | 225.8 | 20.31 | 0.68 | 0.85 | 1 | |
| | 9600 | 271.3 | 14.98 | 0.67 | 0.83 | 1 | 259.4 | 16.57 | 0.68 | 0.86 | 1 | 244.8 | 18.34 | 0.7 | 0.9 | 1 | 230.6 | 20.39 | 0.72 | 0.94 | 1 | |
| 71°F | 6400 | 265.2 | 14.88 | 0.47 | 0.58 | 0.69 | 253.5 | 16.47 | 0.47 | 0.59 | 0.7 | 241.5 | 18.29 | 0.48 | 0.6 | 0.72 | 228.4 | 20.36 | 0.49 | 0.61 | 0.79 | |
| | 8000 | 277.5 | 15.08 | 0.49 | 0.62 | 0.74 | 265 | 16.66 | 0.5 | 0.63 | 0.77 | 251 | 18.45 | 0.51 | 0.64 | 0.79 | 237.2 | 20.5 | 0.52 | 0.67 | 0.86 | |
| | 9600 | 284.2 | 15.19 | 0.52 | 0.66 | 0.81 | 272 | 16.77 | 0.53 | 0.68 | 0.84 | 258.3 | 18.57 | 0.54 | 0.69 | 0.87 | 243.4 | 20.6 | 0.55 | 0.72 | 0.94 | |

RATINGS

TWO OUTDOOR UNITS + ONE INDOOR UNIT

NOTE - For Temperatures and Capacities not shown in tables, see bulletin - Cooling Unit Rating Table Correction Factor Data in Miscellaneous Engineering Data section.

(2) EL090KCSST + EL180KASD - 2 COMPRESSORS - PART LOAD (1 Per Unit at Low Stage)

| Entering Wet Bulb Temperature | Total Air Volume | Outdoor Air Temperature Entering Outdoor Coil | | | | | | | | | | | | | | | | | | | |
|-------------------------------|------------------|---|-------------------|-------------------------------|------|-------|-----------------|-------------------|-------------------------------|------|-------|-----------------|-------------------|-------------------------------|------|-------|-----------------|-------------------|-------------------------------|------|------|
| | | 65°F | | | | | 75°F | | | | | 85°F | | | | | 95°F | | | | |
| | | Total Cool Cap. | Comp. Motor Input | Sensible To Total Ratio (S/T) | | | Total Cool Cap. | Comp. Motor Input | Sensible To Total Ratio (S/T) | | | Total Cool Cap. | Comp. Motor Input | Sensible To Total Ratio (S/T) | | | Total Cool Cap. | Comp. Motor Input | Sensible To Total Ratio (S/T) | | |
| | | | | Dry Bulb | | | | | Dry Bulb | | | | | Dry Bulb | | | | | Dry Bulb | | |
| cfm | kBtuh | kW | 75°F | 80°F | 85°F | kBtuh | kW | 75°F | 80°F | 85°F | kBtuh | kW | 75°F | 80°F | 85°F | kBtuh | kW | 75°F | 80°F | 85°F | |
| 63°F | 3200 | 128.9 | 5.63 | 0.73 | 0.85 | 0.96 | 123.8 | 6.59 | 0.74 | 0.86 | 0.99 | 118.9 | 7.68 | 0.76 | 0.88 | 1 | 112.1 | 8.92 | 0.78 | 0.91 | 1 |
| | 4000 | 136.5 | 5.58 | 0.78 | 0.92 | 1 | 130.8 | 6.56 | 0.79 | 0.94 | 1 | 124.2 | 7.66 | 0.81 | 0.97 | 1 | 117.5 | 8.9 | 0.84 | 1 | 1 |
| | 4800 | 141.8 | 5.53 | 0.83 | 0.99 | 1 | 135.1 | 6.53 | 0.85 | 1 | 1 | 128.6 | 7.64 | 0.87 | 1 | 1 | 122.1 | 8.88 | 0.9 | 1 | 1 |
| 67°F | 3200 | 137.3 | 5.58 | 0.6 | 0.71 | 0.81 | 132 | 6.55 | 0.61 | 0.72 | 0.83 | 125.6 | 7.66 | 0.62 | 0.74 | 0.85 | 119.7 | 8.89 | 0.63 | 0.75 | 0.88 |
| | 4000 | 144.6 | 5.51 | 0.64 | 0.76 | 0.89 | 138.5 | 6.51 | 0.65 | 0.78 | 0.91 | 132.1 | 7.63 | 0.66 | 0.8 | 0.93 | 125.5 | 8.87 | 0.68 | 0.82 | 0.97 |
| | 4800 | 150 | 5.49 | 0.67 | 0.81 | 0.96 | 143.8 | 6.48 | 0.69 | 0.83 | 0.98 | 137.1 | 7.6 | 0.7 | 0.86 | 1 | 130.3 | 8.85 | 0.72 | 0.88 | 1 |
| 71°F | 3200 | 145.3 | 5.51 | 0.49 | 0.59 | 0.69 | 138.8 | 6.51 | 0.5 | 0.6 | 0.7 | 133.2 | 7.62 | 0.5 | 0.61 | 0.72 | 126.6 | 8.86 | 0.51 | 0.62 | 0.73 |
| | 4000 | 152.6 | 5.46 | 0.51 | 0.63 | 0.74 | 146.2 | 6.47 | 0.51 | 0.64 | 0.76 | 140.2 | 7.6 | 0.51 | 0.65 | 0.78 | 133.1 | 8.84 | 0.52 | 0.67 | 0.8 |
| | 4800 | 158.5 | 5.42 | 0.52 | 0.67 | 0.8 | 151.9 | 6.45 | 0.53 | 0.68 | 0.81 | 144.8 | 7.57 | 0.55 | 0.7 | 0.84 | 137.4 | 8.83 | 0.55 | 0.71 | 0.87 |

(2) EL090KCSST + EL180KASD - 2 COMPRESSORS - FULL LOAD (1 Per Unit at High Stage)

| Entering Wet Bulb Temperature | Total Air Volume | Outdoor Air Temperature Entering Outdoor Coil | | | | | | | | | | | | | | | | | | | |
|-------------------------------|------------------|---|-------------------|-------------------------------|------|-------|-----------------|-------------------|-------------------------------|------|-------|-----------------|-------------------|-------------------------------|------|-------|-----------------|-------------------|-------------------------------|------|------|
| | | 85°F | | | | | 95°F | | | | | 105°F | | | | | 115°F | | | | |
| | | Total Cool Cap. | Comp. Motor Input | Sensible To Total Ratio (S/T) | | | Total Cool Cap. | Comp. Motor Input | Sensible To Total Ratio (S/T) | | | Total Cool Cap. | Comp. Motor Input | Sensible To Total Ratio (S/T) | | | Total Cool Cap. | Comp. Motor Input | Sensible To Total Ratio (S/T) | | |
| | | | | Dry Bulb | | | | | Dry Bulb | | | | | Dry Bulb | | | | | Dry Bulb | | |
| cfm | kBtuh | kW | 75°F | 80°F | 85°F | kBtuh | kW | 75°F | 80°F | 85°F | kBtuh | kW | 75°F | 80°F | 85°F | kBtuh | kW | 75°F | 80°F | 85°F | |
| 63°F | 4800 | 175.4 | 11.84 | 0.76 | 0.88 | 1 | 167.5 | 13.29 | 0.77 | 0.91 | 1 | 158.8 | 14.92 | 0.79 | 0.93 | 1 | 150 | 16.76 | 0.81 | 0.96 | 1 |
| | 6000 | 183.7 | 11.96 | 0.81 | 0.96 | 1 | 175.2 | 13.41 | 0.83 | 0.99 | 1 | 165.4 | 15.03 | 0.86 | 1 | 1 | 156.3 | 16.86 | 0.89 | 1 | 1 |
| | 7200 | 188.7 | 12.03 | 0.87 | 1 | 1 | 180.7 | 13.5 | 0.9 | 1 | 1 | 170.7 | 15.12 | 0.93 | 1 | 1 | 162.2 | 16.96 | 0.96 | 1 | 1 |
| 67°F | 4800 | 185.1 | 11.98 | 0.63 | 0.74 | 0.85 | 177.1 | 13.44 | 0.63 | 0.75 | 0.88 | 168.1 | 15.07 | 0.65 | 0.77 | 0.9 | 159.1 | 16.91 | 0.66 | 0.8 | 0.94 |
| | 6000 | 194 | 12.12 | 0.67 | 0.8 | 0.93 | 184.9 | 13.57 | 0.68 | 0.82 | 0.96 | 175.1 | 15.2 | 0.69 | 0.84 | 0.99 | 165.1 | 17.02 | 0.71 | 0.87 | 1 |
| | 7200 | 200.2 | 12.21 | 0.7 | 0.86 | 1 | 190.6 | 13.66 | 0.71 | 0.88 | 1 | 180.1 | 15.28 | 0.74 | 0.91 | 1 | 169 | 17.08 | 0.76 | 0.95 | 1 |
| 71°F | 4800 | 195.2 | 12.14 | 0.5 | 0.61 | 0.72 | 185.2 | 13.6 | 0.5 | 0.63 | 0.74 | 177 | 15.23 | 0.52 | 0.64 | 0.76 | 166.5 | 17.04 | 0.52 | 0.66 | 0.78 |
| | 6000 | 203.7 | 12.28 | 0.52 | 0.66 | 0.78 | 194.4 | 13.72 | 0.52 | 0.67 | 0.8 | 184.3 | 15.36 | 0.53 | 0.69 | 0.83 | 173.5 | 17.17 | 0.55 | 0.71 | 0.86 |
| | 7200 | 210.5 | 12.38 | 0.54 | 0.7 | 0.84 | 200.5 | 13.82 | 0.55 | 0.71 | 0.87 | 189.5 | 15.45 | 0.56 | 0.74 | 0.9 | 177.9 | 17.25 | 0.58 | 0.76 | 0.94 |

(2) EL120KCSST + EL240KASD - 2 COMPRESSORS - PART LOAD (1 Per Unit at Low Stage)

| Entering Wet Bulb Temperature | Total Air Volume | Outdoor Air Temperature Entering Outdoor Coil | | | | | | | | | | | | | | | | | | | |
|-------------------------------|------------------|---|-------------------|-------------------------------|------|-------|-----------------|-------------------|-------------------------------|------|-------|-----------------|-------------------|-------------------------------|------|-------|-----------------|-------------------|-------------------------------|------|------|
| | | 65°F | | | | | 75°F | | | | | 85°F | | | | | 95°F | | | | |
| | | Total Cool Cap. | Comp. Motor Input | Sensible To Total Ratio (S/T) | | | Total Cool Cap. | Comp. Motor Input | Sensible To Total Ratio (S/T) | | | Total Cool Cap. | Comp. Motor Input | Sensible To Total Ratio (S/T) | | | Total Cool Cap. | Comp. Motor Input | Sensible To Total Ratio (S/T) | | |
| | | | | Dry Bulb | | | | | Dry Bulb | | | | | Dry Bulb | | | | | Dry Bulb | | |
| cfm | kBtuh | kW | 75°F | 80°F | 85°F | kBtuh | kW | 75°F | 80°F | 85°F | kBtuh | kW | 75°F | 80°F | 85°F | kBtuh | kW | 75°F | 80°F | 85°F | |
| 63°F | 4160 | 167.2 | 6.73 | 0.7 | 0.82 | 1 | 161 | 7.87 | 0.72 | 0.84 | 1 | 153.6 | 9.15 | 0.73 | 0.88 | 1 | 145.2 | 10.59 | 0.75 | 0.93 | 1 |
| | 5200 | 176.3 | 6.72 | 0.75 | 0.95 | 1 | 168.9 | 7.84 | 0.77 | 0.98 | 1 | 161 | 9.12 | 0.79 | 1 | 1 | 151 | 10.56 | 0.83 | 1 | 1 |
| | 6240 | 181.9 | 6.71 | 0.82 | 1 | 1 | 174.8 | 7.83 | 0.86 | 1 | 1 | 167.6 | 9.1 | 0.89 | 1 | 1 | 159.4 | 10.53 | 0.94 | 1 | 1 |
| 67°F | 4160 | 178.5 | 6.72 | 0.58 | 0.68 | 0.78 | 172 | 7.83 | 0.59 | 0.7 | 0.8 | 164.2 | 9.11 | 0.61 | 0.71 | 0.83 | 155.6 | 10.54 | 0.62 | 0.73 | 0.89 |
| | 5200 | 187.1 | 6.69 | 0.62 | 0.74 | 0.9 | 180.2 | 7.81 | 0.64 | 0.75 | 0.94 | 172.1 | 9.08 | 0.65 | 0.77 | 0.99 | 161.8 | 10.52 | 0.66 | 0.8 | 1 |
| | 6240 | 193.5 | 6.69 | 0.66 | 0.8 | 1 | 186.2 | 7.79 | 0.67 | 0.84 | 1 | 177.8 | 9.07 | 0.69 | 0.87 | 1 | 166.7 | 10.5 | 0.71 | 0.92 | 1 |
| 71°F | 4160 | 188.9 | 6.69 | 0.48 | 0.57 | 0.67 | 182.2 | 7.8 | 0.49 | 0.58 | 0.68 | 174.6 | 9.08 | 0.49 | 0.59 | 0.69 | 164.7 | 10.51 | 0.5 | 0.61 | 0.71 |
| | 5200 | 198.2 | 6.69 | 0.51 | 0.62 | 0.73 | 191.1 | 7.79 | 0.52 | 0.63 | 0.74 | 181.9 | 9.06 | 0.52 | 0.64 | 0.76 | 172.4 | 10.49 | 0.52 | 0.66 | 0.78 |
| | 6240 | 204.8 | 6.68 | 0.53 | 0.66 | 0.79 | 198 | 7.78 | 0.52 | 0.68 | 0.81 | 187.8 | 9.04 | 0.55 | 0.69 | 0.84 | 177.8 | 10.48 | 0.54 | 0.71 | 0.92 |

(2) EL120KCSST + EL240KASD - 2 COMPRESSORS - FULL LOAD (1 Per Unit at High Stage)

| Entering Wet Bulb Temperature | Total Air Volume | Outdoor Air Temperature Entering Outdoor Coil | | | | | | | | | | | | | | | | | | | |
|-------------------------------|------------------|---|-------------------|-------------------------------|------|-------|-----------------|-------------------|-------------------------------|------|-------|-----------------|-------------------|-------------------------------|------|-------|-----------------|-------------------|-------------------------------|------|------|
| | | 85°F | | | | | 95°F | | | | | 105°F | | | | | 115°F | | | | |
| | | Total Cool Cap. | Comp. Motor Input | Sensible To Total Ratio (S/T) | | | Total Cool Cap. | Comp. Motor Input | Sensible To Total Ratio (S/T) | | | Total Cool Cap. | Comp. Motor Input | Sensible To Total Ratio (S/T) | | | Total Cool Cap. | Comp. Motor Input | Sensible To Total Ratio (S/T) | | |
| | | | | Dry Bulb | | | | | Dry Bulb | | | | | Dry Bulb | | | | | Dry Bulb | | |
| cfm | kBtuh | kW | 75°F | 80°F | 85°F | kBtuh | kW | 75°F | 80°F | 85°F | kBtuh | kW | 75°F | 80°F | 85°F | kBtuh | kW | 75°F | 80°F | 85°F | |
| 63°F | 6400 | 230.8 | 14.47 | 0.73 | 0.89 | 1 | 221.2 | 16.12 | 0.75 | 0.92 | 1 | 208.8 | 17.9 | 0.77 | 0.98 | 1 | 198.3 | 19.98 | 0.79 | 1 | 1 |
| | 8000 | 241.6 | 14.66 | 0.79 | 1 | 1 | 229.1 | 16.25 | 0.82 | 1 | 1 | 217.3 | 18.05 | 0.87 | 1 | 1 | 206.8 | 20.14 | 0.93 | 1 | 1 |
| | 9600 | 247.7 | 14.77 | 0.9 | 1 | 1 | 238.5 | 16.4 | 0.95 | 1 | 1 | 227.8 | 18.24 | 1 | 1 | 1 | 215.5 | 20.3 | 1 | 1 | 1 |
| 67°F | 6400 | 245.7 | 14.73 | 0.61 | 0.72 | 0.85 | 234.4 | 16.34 | 0.62 | 0.73 | 0.88 | 223.4 | 18.16 | 0.64 | 0.76 | 0.94 | 209.2 | 20.18 | 0.64 | 0.78 | 0.99 |
| | 8000 | 254.6 | 14.89 | 0.65 | 0.78 | 0.99 | 242.3 | 16.45 | 0.67 | 0.8 | 1 | 230.3 | 18.29 | 0.68 | 0.84 | 1 | 216.7 | 20.35 | 0.7 | 0.9 | 1 |
| | 9600 | 261.6 | 15.01 | 0.7 | 0.87 | 1 | 251.5 | 16.64 | 0.71 | 0.92 | 1 | 236.8 | 18.4 | 0.74 | 0.99 | 1 | 222.8 | 20.43 | 0.77 | 1 | 1 |
| 71°F | 6400 | 258.1 | 14.95 | 0.48 | 0.6 | 0.7 | 248.8 | 16.57 | 0.49 | 0.62 | 0.72 | 235.4 | 18.37 | 0.5 | 0.63 | 0.75 | 222 | 20.42 | 0.52 | 0.64 | 0.76 |
| | 8000 | 269.7 | 15.14 | 0.52 | 0.65 | 0.77 | 257.1 | 16.71 | 0.53 | 0.67 | 0.79 | 243.9 | 18.51 | 0.55 | 0.68 | 0.81 | 228.8 | 20.53 | 0.57 | 0.72 | 0.87 |
| | 9600 | 277.1 | 15.25 | 0.58 | 0.69 | 0.86 | 264.3 | 16.84 | 0.59 | 0.71 | 0.89 | 250.3 | 18.63 | 0.6 | 0.73 | 0.97 | 234.8 | 20.65 | 0.62 | 0.78 | 1 |

REVISIONS

| Sections | Description of Change |
|---------------------|------------------------------------|
| AHRI Ratings | Removed all matches with furnaces. |
| Options/Accessories | Removed Twinning Panel. |



Visit us at www.Lennox.com

For the latest technical information, www.LennoxCommercial.com

Contact us at 1-800-4-LENNOX

NOTE - Due to Lennox' ongoing commitment to quality, Specifications, Ratings and Dimensions subject to change without notice and without incurring liability. Improper installation, adjustment, alteration, service or maintenance can cause property damage or personal injury. Installation and service must be performed by a qualified installer and servicing agency.

©2026 Lennox Industries, Inc.