

# LGT

## ENLIGHT ROOFTOP UNITS

High Efficiency | Lennox® CORE Controller | Environ™ Coil | **R-454B** | 60Hz



### COMMERCIAL PRODUCT SPECIFICATIONS (EHB)

3 to 6 Tons  
Net Cooling Capacity | 36,000 to 69,000 Btuh  
Gas Input Heat Capacity | 65,000 to 150,000 Btuh

# ENLIGHT



SMART WIRE™ SYSTEM



### MODEL NUMBER IDENTIFICATION

**L G T 0 6 0 H 5 E B 1 Y**

**Brand**  
L = Lennox®

**Unit Type**  
G = Packaged Gas Heat w/ Electric Cooling

**Family**  
T = Enlight Series

**Nominal Cooling Capacity - Tons**  
036 = 3 Tons  
048 = 4 Tons  
060 = 5 Tons  
072 = 6 Tons

**Cooling Efficiency**  
H = High Efficiency

**Refrigerant Type**  
5 = R-454B

**Voltage**  
P = 208/230V-1 phase-60Hz  
Y = 208/230V-3 phase-60Hz  
G = 460V-3 phase-60Hz  
J = 575V-3 phase-60Hz

**Minor Design Sequence**  
1 = 1st Revision

**Heating Type**  
**Two-Stage**  
B = Standard Gas Heat, 2 Stage, Low NOx  
Q = Medium Gas Heat, 2 Stage, Low NOx  
X = High Gas Heat, 2 Stage, Low NOx  
**Modulating**  
P = Standard Gas Heat, Modulating, Low NOx  
K = Medium Gas Heat, Modulating, Low NOx  
R = High Gas Heat, Modulating, Low NOx

**Blower Type**  
E = ECM (MSAV®) Direct Drive Blower Motor

## FEATURE HIGHLIGHTS

Enlight rooftop units featuring the Lennox® CORE Control System create a bright future through a highly energy-efficient and environmentally sustainable design. Comprehensive configurations meet a wide range of applications, making it the most flexible product line Lennox has to offer.

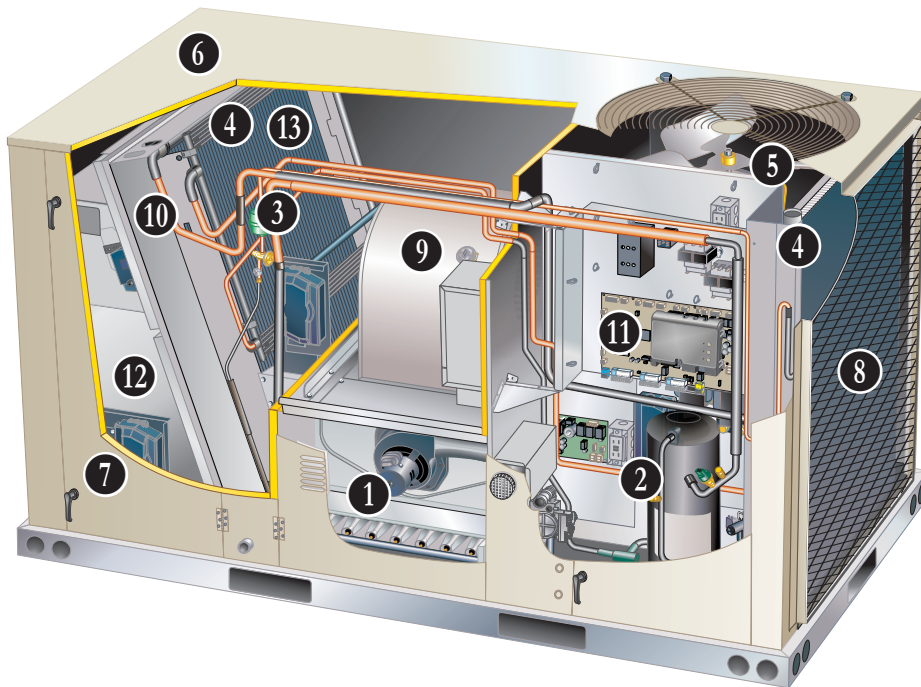

1. Aluminized steel inshot burners
2. Two-Stage Compressor
3. Filter/Drier
4. Environ™ Coil System
5. Variable Speed (ECM) Fan Motor
6. Heavy Gauge Steel Cabinet
7. Hinged Access Panels
8. Combination Coil/Hail Guards (option)
9. Supply Air Direct Drive (ECM) Blower
10. Air Filters
11. Lennox® CORE Control System
12. Economizer (option)
13. Humiditrol® Dehumidification (option)

## CONTENTS

Approvals And Warranty . . . . .	3
Blower Data . . . . .	25
- 0.5 HP . . . . .	25
- 1.0 HP . . . . .	26
- 1.5 HP . . . . .	27
Control System . . . . .	8
Dimensions . . . . .	35
- Accessories . . . . .	36
- Unit . . . . .	35
Electrical Data . . . . .	31
Features And Benefits . . . . .	3
High Altitude Derate . . . . .	21
Humiditrol® Dehumidification System Option . . . . .	12
Humiditrol® Dehumidification System Ratings . . . . .	24
Model Number Identification . . . . .	1
Optional Conventional Temperature Control Systems . . . . .	13
Options / Accessories . . . . .	17
Outdoor Sound Data . . . . .	33
Sequence Of Operation . . . . .	16
Specifications . . . . .	20
- Low NOx Gas Heat . . . . .	21
Unit Clearances . . . . .	34
Weight Data . . . . .	33
- Unit . . . . .	33

## APPROVALS AND WARRANTY

### APPROVALS

- All 3-5 ton models are AHRI Standard 210/240-2024 certified
- All 6 ton models are AHRI Standard 340/360-2022 certified
- ENERGY STAR® certified (certain models)
- ETL and CSA listed
- All models are ASHRAE 90.1-2025 compliant
- All models meet DOE 2023 energy efficiency standards
- All models are listed to UL 60335-1 and UL 60335-2-40 and meet the Refrigerant Detection and Dissipation Requirements
- Components are bonded for grounding to meet safety standards for servicing required by ETL, NEC and CEC
- All 6 ton models meet California Code of Regulations, Title 24 and ASHRAE 90.1-2025 Section 6.4.3.10 requirements for staged airflow
- All models have been sound tested in accordance with test conditions included in AHRI Standard 270 or 370
- ISO 9001 Registered Manufacturing Quality System
- All models have HCAI (formerly OSHPD) OSP and Special Seismic Certification (Number: [OSP-0596](#)), and meet 2021 International Building Code (IBC), 2022 California Building Code (CBC) ASCE 7, and ICC-ES AC156
- All models have FSA approval and are compliant with standard ASCE 7-22 (ASD) and the Florida Building Code Eighth Edition (2023)
- Units are charged with virgin refrigerant to comply with NYCRR Part 494
- All models are fully charged and run tested to verify unit operation and functionality

### California Only

- These gas units do not meet the South Coast Air Quality Management District (SCAQMD) Rule 1111 and San Joaquin Valley Air Pollution Control District (SJVAPCD) Rule 4905 NOx emission limit (14 ng/J) and cannot be installed within the SCAQMD and SJVAPCD areas
- These gas units are approved by the California Energy Commission and meets California Nitrogen Oxides Standard (NOx) limits of 40 ng/J

### WARRANTY

- Aluminized Heat Exchanger - Limited ten years
- Stainless Steel Heat Exchanger (optional) - Limited fifteen years
- Compressors - Limited five years
- Environ™ Coil System - Limited three years
- Lennox® CORE Unit Controller - Limited three years
- High Performance Economizers (optional) - Limited five years
- All other covered components - Limited one year

## FEATURES AND BENEFITS

### HEATING SYSTEM

#### Heat Exchanger

- 1 • Aluminized steel inshot burners
- Direct spark ignition
- Electronic flame sensor
- Combustion air inducer
- Redundant automatic gas valve with manual shut-off

#### Heat Exchanger

- Tubular construction, aluminized steel, life cycle tested

**NOTE** - Optional Stainless Steel Heat Exchanger is required if mixed air temperature is below 45°F.

### Limit Controls

- Factory installed, redundant limit controls with fixed temperature setting
- Heat limit controls protect heat exchanger and other components from overheating

### Safety Switches

- Flame roll-out switch, flame sensor and combustion air inducer proving switch protect system operation
- All safety switches are monitored by the Lennox® CORE Unit Controller and diagnostic information is reported and recorded

### Two-Stage Gas Heat

- Two-Stage gas valve adjusts heat for low and high output

**NOTE** - Modulating Gas Heat may be ordered as a factory installed option. See Options/Accessories table.

## FEATURES AND BENEFITS

### HEATING SYSTEM (continued)

#### Required Selections

##### Gas Input Choice - Order one:

- Standard Gas Heat (all models) 53,000-65,000 Btuh
- Medium Gas Heat (all models) 81,000-108,000 Btuh
- High Gas Heat (048-072 models) 113,000-150,000 Btuh
- See Gas Heat Specifications Tables on page 21

**NOTE** - All models are furnished with Low NOx (40 ng/J) gas heat.

#### Options/Accessories

##### Factory Installed

##### Modulating Gas Heat

- Modulating gas valve adjusts heat output in real time based on demand for smoother temperature control
- Includes two factory-installed sensors:
  - Mixed Air Sensor
  - Indirect Sensing Discharge Air Temperature Sensor

**NOTE** - Modulating Gas Heat for Horizontal Applications requires a Remote Discharge Air Temperature Sensor / Fresh Air Tempering. Sensor is shipped with the unit for field installation if unit is configured at the factory. Sensor must be ordered separately for field installation if unit is not factory configured.

##### Stainless Steel Heat Exchanger

- Required if mixed air temperature is below 45 °F

##### Vertical Vent Extension Kit

- Use to exhaust flue gases vertically above unit
- Required when unit vent is too close to fresh air intakes per building codes
- Prevents ice formation on intake louvers
- Kit contains vent transition, drain cap, and installation hardware

**NOTE** - Straight vent pipe (3 in. B-Vent), vent tee and vent cap are not furnished and must be field supplied. Refer to kit instructions for additional information.

##### Field Installed

##### Combustion Air Intake Extensions

- Recommended for use with existing flue extension kits in areas where high snow can block intake air

##### Low Temperature Vestibule Heater

- Extends gas heat operation from -40°F (standard) down to -60°F
- Electric heater automatically controls minimum temperature in gas burner compartment when temperature falls below -40°F

##### LPG/Propane Kits

- Conversion kit to field change over units from Natural Gas to LPG/Propane

### COOLING SYSTEM

- Designed to maximize sensible and latent cooling performance at design conditions
- System can operate from 0°F to 125°F without any additional controls

##### R-454B Refrigerant

- Low GWP (Global Warming Potential)
- Zero ODP (Ozone Depletion Potential)
- Low Toxicity/Lower Flammability - A2L
- Unit is factory pre-charged

#### 2 Two-Stage Compressor

- Two-stage scroll compressors on all models for high performance, reliability, quiet operation, and increased part-load efficiency
- Resiliently mounted on rubber grommets for quiet operation

##### Compressor Crankcase Heater

- Protects against refrigerant migration that can occur during low ambient operation or during extended off cycles

##### Thermal Expansion Valve

- Ensures optimal performance throughout the application range
- Removable element head

#### 3 Filter/Drier

- High capacity filter/drier protects the system from dirt and moisture

##### High Pressure Switch

- Protects the compressor from overload conditions such as dirty condenser coils, blocked refrigerant flow, or loss of outdoor fan operation

##### Low Pressure Switch

- Protects the compressor from low pressure conditions such as low refrigerant charge or low/no airflow

##### Indoor Coil Freeze Protection

- Protects the evaporator coil from damaging ice build-up due to conditions such as low/no airflow or low refrigerant charge

#### 4 Environ™ Coil System

- Condenser and evaporator coil
- Coils feature lightweight, all aluminum brazed fin construction
- Constructed of three components:
  - A flat extrusion tube
  - Fins in-between the flat extrusion tube
  - Two refrigerant manifolds

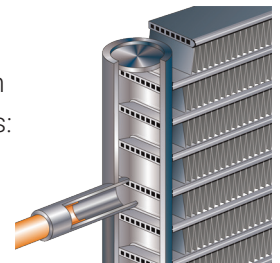

## FEATURES AND BENEFITS

### COOLING SYSTEM (continued)

Environ™

#### Coil System Features:

- Improved heat transfer performance due to high primary surface area (flat tubes) versus secondary surface (fins)
- High durability
- All aluminum construction
- Fewer brazed joints
- Compact design
- Reduced unit weight
- Easy maintenance/cleaning
- Condenser coil has mounting brackets with rubber inserts which secures coil to unit providing vibration dampening and corrosion protection
- Hydrophilic fin surfaces on evaporator coil repel water and direct condensation down the surface into drain pan

#### Antimicrobial Condensate Drain Pan

- Composite pan, sloped to meet drainage requirements of ASHRAE 62.1
- Antimicrobial additive resists growth of mold and mildew on drain pan, which improves indoor air quality and reduces drain line blockage
- Side or bottom drain connections
- Reversible to allow connection at back of unit

### 5 Variable Speed Outdoor Coil Fan Motor

- Variable speed (ECM) fan motor for energy efficient performance and quiet operation
- Thermal overload protected
- Totally enclosed
- Permanently lubricated ball bearings
- Shaft up
- Wire basket mount

#### Outdoor Coil Fan

- PVC coated fan guard furnished

#### Required Selections

#### Cooling Capacity

- Specify nominal cooling capacity

#### Options/Accessories

#### Factory or Field Installed

##### Drain Pan Overflow Switch

- Monitors condensate level in drain pan
- Shuts down unit if drain becomes clogged

#### Field Installed

##### Condensate Drain Trap

- Constructed of PVC or copper

### LOW GWP REFRIGERANT DETECTION SYSTEM (RDS)

- Complies with UL 60335-2-40 approved standard
- Required for all systems using R-454B refrigerant
- Factory installed on all units

- Consists of a refrigerant detection sensor(s) and a mitigation control
- Ensures safe operation for systems equipped with R-454B refrigerant
- Sensor(s) monitors indoor coil area for R-454B refrigerant
- If R-454B refrigerant is detected the refrigerant detection system will prevent compressor and heating operation until R-454B refrigerant is no longer detected
- Refrigeration detection system energizes blower if any R-454B refrigerant is detected to mitigate any concentrations of refrigerant from the unit and the system

### CABINET

### 6 Construction

- Heavy-gauge steel panels
- Full perimeter heavy-gauge galvanized steel base rail
- Base rails have rigging holes
- Three sides of the base rail have forklift slots
- Raised edges around duct and power entry openings in the bottom of the unit for water protection

#### Airflow Choice

- Units are shipped in downflow (vertical) return air flow configuration

**NOTE** - Can be field converted to horizontal airflow configuration without any optional kits.

#### Duct Flanges

- Provided for horizontal duct attachment

#### Power/Gas Entry

- Electrical and gas lines can be routed through the unit base or through horizontal access knock-outs

#### Exterior Panels

- Constructed of heavy-gauge, galvanized steel
- Textured pre-paint with polyurethane finish
- Cyclic salt fog and UV exposure up to 1,680 hours per ASTM D5894

#### Insulation

- Fully insulated with non-hygroscopic fiberglass insulation (conditioned areas)
- Unit base is fully insulated
- Base insulation serves as an air seal to the roof curb, eliminating the need to add a seal during installation

### 7 Hinged Access Panels

- Tool-less access
- Economizer/Filter sections
- Compressor/Controls sections
- Panel seals and quarter-turn latching handles provide a tight air and water seal

**NOTE** - Optional Economizers, Power Exhaust, Outdoor Air Dampers and Barometric Relief Dampers include a filler panel for proper cabinet fit.

## FEATURES AND BENEFITS

### **CABINET (continued)**

#### Required Selections

##### Airflow Configuration

- Specify horizontal or downflow

#### Options/Accessories

##### **Factory Installed**

##### Corrosion Protection

- Completely flexible immersed coating
- Electrodeposited dry film process (AST ElectroFin E-Coat)
- ASTM B117 / DIN 53167 Salt Spray - 15,000+ hours
- ASTM G85 Annex A3 SWAAT Modified Salt Spray - 3,000 hours
- VA Master Construction Specification Division 23 for High Humidity Installations
- CID AA-52474A (GSA)
- Indoor Corrosion Protection:
  - Coated coil
  - Coated reheat coil
  - Painted blower housing
  - Painted base
- Outdoor Corrosion Protection:
  - Coated coil
  - Painted outdoor base

##### **Factory or Field Installed**

#### **8** Combination Coil/Hail Guards

- Heavy gauge steel frame
- Painted to match cabinet
- Expanded metal mesh protects outdoor coil

#### Options/Accessories

##### **Field Installed**

##### Burglar Bars

- Heavy gauge galvanized frame
- Fully welded
- 3/4 in. bar meets ASTM specification
- Frame meets ASTM A446, A525, A526 and A527 specification
- Burglar bars designed to fit ductwork

### **BLOWER**

- 9** A wide selection of supply air blower options are available to meet a variety of airflow requirements.

#### Variable-Speed ECM Direct Drive Motor

- 036, 048 and 060 models

#### DirectPlus™ Direct Drive ECM Blower System

- Optional on 036, 048 and 060 3 phase models, standard on 072 model.
- High-efficiency, variable-speed ECM (electronically commutated) motor
- Eliminates the need for a separate variable-frequency drive
- Advanced Blower Diagnostics: Lennox® CORE Unit Controller communicates via Modbus with DirectPlus™ blower to provide control commands, blower proving functionality, and detailed alarm codes
- MSAV control modulates the amount of supply blower airflow according to cooling demand, heating demand, ventilation demand or smoke alarm
- The amount of airflow for each stage can be set according to a parameter in the Lennox® CORE Unit Controller
- Unit is shipped from the factory with preset airflows
- Fully variable speed motor modulates to maximize system efficiency
- Combines the motor and electronics into one unit
- Aerodynamically optimized impeller with curved blades mounted directly onto the rotor



- Air inlet grill reduces indoor sound levels without affecting air performance

#### Required Selections

##### Blower Motor

- Specify Standard Static or High Static (3-5 ton models only)

### **ELECTRICAL**

#### SmartWire™ System

- Keyed and color-coded wiring connectors prevent miswiring
- Wire coloring scheme is standardized across all models
- Each connection is intuitively labeled to make troubleshooting and servicing quick and easy

#### Electrical Plugs

- Positive connection electrical plugs are used to connect common accessories or maintenance parts for easy removal or installation

## FEATURES AND BENEFITS

### ELECTRICAL

#### Required Selections

##### Voltage Choice

- Specify when ordering base unit

#### Options/Accessories

### Factory Installed

##### Circuit Breakers

- HACR type
- For overload and short circuit protection
- Factory wired and mounted in the power entry panel
- Current sensitive and temperature activated
- Manual reset

##### Phase/Voltage Detection (3 Phase models only)

- Monitors power supply to ensure phase is correct at unit start-up
  - If phase is incorrect, the unit will not start and an alarm code is reported to the unit controller
- Protects unit from being started with incorrect phasing, which could lead to issues such as compressors running backwards
- Voltage detection monitors power supply voltage to ensure proper voltage
  - If voltage is not correct (over/under voltage conditions) the unit will not start and an alarm code is reported to the unit controller

##### Short-Circuit Current Rating (SCCR)

- Higher short circuit protection up to 100kA

**NOTE** - Disconnect Switch is furnished and factory installed with High SCCR option.

### Factory or Field Installed

##### Disconnect Switch

- Accessible outside of unit
- Spring loaded weatherproof cover furnished

##### GFI Service Outlets (2)

- 115V ground fault circuit interrupter (GFCI) type options:
  - Factory installed, powered and wired
  - Factory installed, non-powered, field wired
  - Field installed, non-powered, field wired

### INDOOR AIR QUALITY

#### 10 Air Filters

- Disposable 2 inch MERV 4 filters furnished as standard

#### Options/Accessories

### Factory or Field Installed

##### Healthy Climate® High Efficiency Air Filters

- Disposable MERV 8 or MERV 13 (Minimum Efficiency Reporting Value based on ASHRAE 52.2) efficiency 2-inch pleated filters

### Field Installed

##### Healthy Climate® High Efficiency MERV 16 Air Filters

- Disposable MERV 16 (Minimum Efficiency Reporting Value based on ASHRAE 52.2) efficiency 2-inch pleated filters

##### Healthy Climate® UVC Germicidal Lamps

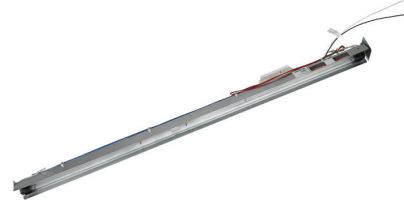

- Germicidal lamps emit ultra-violet (UV-C) energy, which has been proven to be effective in reducing microbes such as viruses, bacteria, yeasts, and molds
- UV-C energy greatly reduces the growth and proliferation of mold and other bioaerosols (bacteria and viruses) on illuminated surfaces (particularly coil and drain pan)
- Destroys the organism or controls its ability to reproduce
- Field installed in the blower/evaporator coil section
- Magnetic safety interlock terminates power when access panels are removed
- All necessary hardware for installation is included
- Lamps operate on 110/230V-1ph power supply

**NOTE** - Step-down transformer may be ordered separately for 460V and 575V units.

- Approved by ETL
- **Needlepoint Bipolar Ionization (NPBI) Kit**
- NPBI technology integrates with system controls for effective air treatment
- Ionization has been shown to effectively reduce harmful pathogens, pollutants, and odors
- Brush-type ionizer introduces a high concentration of both positive and negative ions into the airstream
- These bipolar ions are then dispersed into the occupied space through the duct system proactively reducing the airborne contaminants
- Ions travel within the building air stream and attach to particles, pathogens, and gas molecules, making them larger and easier to capture in the filtration system
- UL 2998 certified for zero ozone emission

##### Indoor Air Quality (CO<sub>2</sub>) Sensors

- Monitors CO<sub>2</sub> levels
- Reports to the Lennox® CORE Unit Controller, which adjusts economizer dampers as needed

##### Replacement Filter Media Kit With Frame

- Replaces existing pleated filter media
- Includes washable metal mesh screen and metal frame with clip for holding replaceable non-pleated filter

## CONTROL SYSTEM

### LENNOX® CORE CONTROL SYSTEM

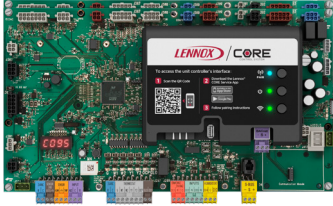

11 The Lennox® CORE Control system is designed to accelerate equipment install and service. Standard with all Enlight rooftop units, control system integrates key technologies that lower installation costs, drive system efficiency, and protect your investments. The Lennox® CORE Unit Controller is a microprocessor-based controller that provides flexible control of all unit functions.

#### CORE Mobile Service App

- Guided Setup with progress indicators, detailed help, and exportable summaries to manage simple, trouble-free setup, reducing commissioning times
- Enhanced Test Functionality provides real-time sensor readings, trending, and reports that enable easy troubleshooting
- Ability to set and configure parameters of the CORE Control System to manage sequence of operation
- Economizer test function ensures economizer is operating correctly



#### Additional Features:

- Built-In 7-Segment Display shows Unit Status and active alarms for easy troubleshooting
- Buttons for test and clearing delays
- SmartWire™ System with keyed and removable screw terminals ensure correct field wiring
- Built-in BACnet MS/TP and IP allow open integration to building management systems
- Two-port Ethernet Switch enables daisy chaining for BACnet IP and automatic firmware updates

**NOTE** - Unit Internet Connection required.

- Profile setup copies key settings between units with the same configuration to reduce setup time
- USB port allows a technician to download and transfer unit information to help verify service was performed
- USB software updates on the Lennox® CORE Unit Controller enhance functionality without the need to change components
- Unit Controller Software

#### Configurable Built-In Functions

- Discharge Air Cooling Control
- Up to three distinct Cooling Airflows in Thermostat Mode
- Programmable independent heating, ventilation and cooling blower speeds

- Discharge Air Heating Control
- Economizer Control Options (See Economizer / Exhaust Air / Outdoor Air sections)
- Exhaust Fan Control Modes for fresh air damper position
- Configurable Morning Warm-up
- Night Setback Mode
- Fresh Air Tempering for Improved Ventilation
- Demand Control Ventilation
- Low Ambient Controls for operation down to 0°F
- Humiditrol® Operation
- Enhanced Dehumidification (Latent Demand Control without hot has reheat)

#### Component Protection / Unit Safeguards:

- Compressor Time-Off Delay
- Adjustable Blower On/Off Delay
- Return Air Temperature Limit Control
- Safety Switch Input allows Controller to respond to an external safety switch trip
- Service Relay Output
- Thermostat Bounce Delay
- Smoke Alarm Mode has four choices (unit off, positive pressure, negative pressure, purge)
- "Strike Three" Protection
- Gas Valve Time Delay Between First and Second Stage
- Minimum Compressor Run Time

#### Control Methods / Interfaces:

- DDC and 24V Thermostat
- BACnet MS/TP and IP
- LONTalk (Factory and Field Option)
- Lennox S-BUS
- Zone Temperature Sensor Input
- Dehumidistat and Humidity Sensor Inputs
- Indoor Air Quality Inputs (2)
- Built-in Control Parameter Defaults
- Permanent Diagnostic Code Storage
- Field Adjustable Control Parameters (Over 200 settings)
- Multiple Configurable Digital Inputs
- LED Indicators
- PC Interface connects the Lennox® CORE Unit Controller to a PC with the Lennox Unit Controller Software

**NOTE** - Lennox® CORE Control System features vary with the type of rooftop unit in which the control is installed.

## CONTROL SYSTEM

### LENNOX® CORE CONTROL SYSTEM (continued)

#### Controls Options

##### **Factory or Field Installed**

###### Blower Proving Switch

- Monitors blower operation, shuts down unit if blower fails

###### Dirty Filter Switch

- Senses static pressure increase and issues alarm if necessary

###### Fresh Air Tempering

- Used in applications with high outside air requirements
- Controller energizes the first stage heat as needed to maintain a minimum supply air temperature for comfort, regardless of the thermostat demand
- When ordered as a factory option, sensor ships with the unit for field installation

###### Smoke Detector

- Photoelectric type
- Installed in supply air section, return air section or both sections
- Available with power board and single sensor (supply or return) or power board and two sensors (supply and return)
- Power board located in unit control compartment

##### **Commercial Control Systems**

###### Interoperability via BACnet® or LonTalk® Protocols

- Communication compatible with third-party automation systems that support the BACnet Application Specific Controller device profile, LonMark® Space Comfort Controller functional profile, or LonMark Discharge Air Controller functional profile

##### **Field Installed**

###### Thermostats and Room Sensors

- Control system and thermostat options, see page 13

## OPTIONS / ACCESSORIES

### **ECONOMIZER**

- 12 • Economizer operation is set and controlled by the Lennox® CORE Unit Controller
- Simple plug-in connections from economizer to unit controller for easy installation

- All Enlight rooftop units are equipped with factory installed CEC Title 24 approved sensors for outside, return and discharge air temperature monitoring

**NOTE** - Optional sensors may be used instead of unit sensors to determine whether outdoor air is suitable for free cooling. See Options/Accessories table.

##### **Factory or Field Installed**

###### High Performance Economizer

- Approved for California Title 24 building standards
- Low leakage dampers are Air Movement and Control Association International (AMCA) Class 1A Certified - Maximum 3 CFM per sq. ft. leakage at 1 in. w.g.
- ASHRAE 90.1 compliant
- Combination Outdoor Air Hood is furnished
- Factory installed Economizer can be ordered with three exhaust options:
  - Barometric Relief Dampers
  - Power Exhaust Fan

**NOTE** - See Power Exhaust Fan section for additional requirements.

- No Exhaust
- Field installed Economizer includes Barometric Relief Dampers with Combination Hood
- Barometric Relief Dampers allow relief of excess air
- Dampers prevent blow back and outdoor air infiltration during off cycle
- Bird screen furnished

**NOTE** - Barometric Relief Dampers are required when Economizer is factory installed with factory installed Power Exhaust Fan option. See Power Exhaust Fan section and Options/Accessories table.

- Demand Control Ventilation (DCV) ready using optional CO<sub>2</sub> sensors
- Horizontal Barometric Dampers are required for horizontal Economizer applications and must be ordered separately
- Linked damper action
- High torque 24-volt fully-modulating spring return damper motor
- Return air and outdoor air dampers
- Plug-in connections to unit

## OPTIONS / ACCESSORIES

### **ECONOMIZER (continued)**

#### **Factory or Field Installed (continued)**

**NOTE** - High Performance Economizers are not approved for use with enthalpy controls in Title 24 applications.

**NOTE** - The Free Cooling setpoint for Title 24 applications must be set based on the Climate Zone where the system is installed. See Section 140.4 "Prescriptive Requirements for Space Conditioning Systems" of the California Energy Commission's 2022 Building Energy Efficiency Standards.

**NOTE** - Refer to Installation Instructions for complete setup information.

#### **Differential Sensible Control**

- Factory setting
- Uses outdoor air and return air sensors that are furnished with the unit
- The Lennox® CORE Unit Controller compares outdoor air and return air setpoints and activates the economizer when the outdoor air temperature is below the configured setpoint and cooler than return air

**NOTE** - Differential Sensible Control can be configured in the field to provide Offset Differential Sensible Control or Single Sensible Control.

In Offset Differential Sensible Control mode, the economizer is enabled if the temperature differential (offset) between outdoor air and return air reaches the configured setpoint

In Single Sensible Control mode, the economizer is enabled when outdoor air temperature falls below the configured setpoint

#### **Global Control**

- The unit controller communicates with a DDC system with one global sensor (enthalpy or sensible) to determine whether outside air is suitable for free cooling on all units connected to the control system

**NOTE** - Sensor must be field provided.

**NOTE** - Global control with enthalpy is not approved for Title 24 applications.

#### **Single Enthalpy Temperature Control (Not for Title 24)**

- Outdoor air enthalpy sensor enables Economizer if the outdoor enthalpy is less than the setpoint of the control

#### **Differential Enthalpy Control (Not for Title 24)**

- Order two Single Enthalpy Controls:
  - One is field installed in the return air section
  - One in the outdoor air section
- Allows the economizer control to select between outdoor air or return air, whichever has lower enthalpy

### **Field Installed**

#### **Outdoor Air CFM Control**

- Maintains constant outdoor air volume levels on the supply air fan and varying unit airflows
- References a velocity sensor located in the rooftop unit outdoor air section
- Lennox® CORE Unit Controller changes the economizer position to help minimize the effect of supply fan speed changes on outdoor air volume levels
- Setpoint for outdoor air volume is established by field testing

**NOTE** - Not available with Demand Control Ventilation (CO<sub>2</sub> Sensor) or Building Pressure Control.

#### **Building Pressure Control**

- Maintains constant building pressure level
- Using differential pressure information between the outdoor air and the building air, the Lennox® CORE Unit Controller changes the economizer position to help maintain a constant building pressure

**NOTE** - Not available with Demand Control Ventilation (CO<sub>2</sub> Sensor).

#### **Horizontal Barometric Relief Dampers**

- For use when unit is configured for horizontal applications with an economizer
- Allows relief of excess air
- Blade type dampers prevent blow back and outdoor air infiltration during off cycle
- Field installed in return air duct
- Outdoor air hood with filter bracket included
- Exhaust hood with bird screen furnished
- Requires Horizontal Economizer Conversion Kit

#### **Horizontal Economizer Conversion Kit**

- Insulated panel covers the bottom return air opening on the unit base to convert downflow economizer to horizontal air flow

## OPTIONS / ACCESSORIES

### EXHAUST

#### Factory or Field Installed

##### Power Exhaust Fan

- Installs internal to unit for downflow applications only with economizer option
- Provides exhaust air pressure relief
- Interlocked to run when supply air blower is operating
- Fan runs when outdoor air dampers are 50% open (adjustable)
- Motor is overload protected
- Fan is 16 in. diameter
- Four blades
- One 1/3 HP motor

**NOTE** - If Power Exhaust is field installed with a factory installed Economizer, the Economizer must be ordered with No Exhaust option. Barometric Relief Dampers must also be ordered separately for field installation.

**NOTE** - If Power Exhaust is factory installed with a factory installed Economizer, Barometric Relief Dampers must also be ordered separately for field installation.

### OUTDOOR AIR

#### Factory or Field Installed

##### Motorized Outdoor Air Dampers

- Linked mechanical dampers
- Fully modulating spring return damper motor with plug-in connection
- 0 to 25% (fixed) outdoor air adjustable
- Installs in unit
- Outdoor air hood with bird screen included

**NOTE** - Outdoor Air Hood is shipped separately in the unit with factory installed dampers for field installation.

#### Field Installed

##### Manual Outdoor Air Damper

- Adjustable slide damper
- Installed in unit
- Outdoor air hood with bird screen included

### ROOF CURBS

#### Field Installed

- Nailer strip furnished (downflow only)
- Mates to unit
- US National Roofing Contractors Approved
- Shipped knocked down

#### Hybrid Roof Curbs, Downflow

- Interlocking tabs fasten corners together
- No tools required for assembly
- Can also be fastened together with furnished hardware
- Available in 8, 14, 18, and 24 inch heights

#### Adjustable Pitch Curb

- Fully adjustable pitch curbs (3/4 in. per foot in any direction) provide a level platform for rooftop units allowing flexible installations on roofs with uneven or sloped angles
- Interlocking tabs fasten corners together
- No tools required for assembly
- Hardware is furnished to connect upper curb with lower curb
- Available in 14 inch height

#### Adaptor Curbs (not shown)

- Curbs are regionally sourced
- Dimensions vary based upon the source

**NOTE** - Contact your local sales representative for a detailed cut sheet with applicable dimensions.

### CEILING DIFFUSERS

#### Field Installed

##### Ceiling Diffusers (Flush or Step-Down)

- White powder coat finish on diffuser face and grilles
- Insulated UL listed duct liner
- Diffuser box has collars for duct connection
- Step-down diffusers have double deflection blades
- Flush diffusers have fixed blades
- Provisions for suspending
- Internally sealed to prevent recirculation
- Removable return air grille
- Adapts to T-bar ceiling grids or plaster ceilings

#### Transitions (Supply and Return)

- Used with diffusers
- Installs in roof curb
- Galvanized steel construction
- Flanges furnished for duct connection to diffusers
- Fully insulated

## HUMIDITROL® DEHUMIDIFICATION SYSTEM OPTION

### 13 OVERVIEW

- Factory installed option designed to control humidity
- Provides dehumidification on demand using ASHRAE 90.1 recommended method for comfort conditioning humidity control
- Unit comes equipped with one row reheat coil, solenoid valve and humidity controller

**NOTE** - A dehumidification demand from a relative humidity sensor, dehumidistat, a DDC controller or building automation system is required to control humidity.

Controls are not furnished and must be ordered separately.

### BENEFITS

- Improves indoor air quality
- Helps prevent damage due to high humidity levels
- Improves comfort levels by reducing space humidity levels

### OPERATION

#### No Dehumidification Demand

- The unit will operate conventionally whenever there is a demand for cooling or heating and no dehumidification demand
- Free cooling is only permitted when there is no demand for dehumidification

#### Dehumidification Demand Only

- Reheat operation will initiate on a dehumidification demand and does not require a cooling demand
- Unit will operate in the dehumidification mode until the relative humidity of the conditioned space is below the setpoint
- Reheat coil is sized to provide 68°F to 75°F supply air during reheat operation
- This reduces sensible cooling capacity and extends compressor run time to control humidity when the cooling load is low
- A solenoid valve diverts hot gas from the compressor to the reheat coil
- Cooled and dehumidified air from the evaporator is reheated as it passes through the reheat coil
- De-superheated and partially condensed refrigerant continues to the outdoor condenser coil where condensing is completed
- Unit will continue to operate in this mode until the dehumidification demand is satisfied

**NOTE** - See Sequence of Operation for additional information.

#### Dehumidification and Cooling Demand (Thermostat/ Room Sensor Application)

- If both a dehumidification and a 1st stage cooling demand occur, the system will operate in the full cooling mode at first stage indoor air flow.
- If a 2nd stage cooling demand occurs along with a dehumidification demand, the system operates in full cooling mode at full cooling airflow until the 2nd stage cooling demand is satisfied
- Then the system will revert to the dehumidification mode if a dehumidification mode demand is present

TYPICAL DEHUMIDIFICATION SCHEMATIC

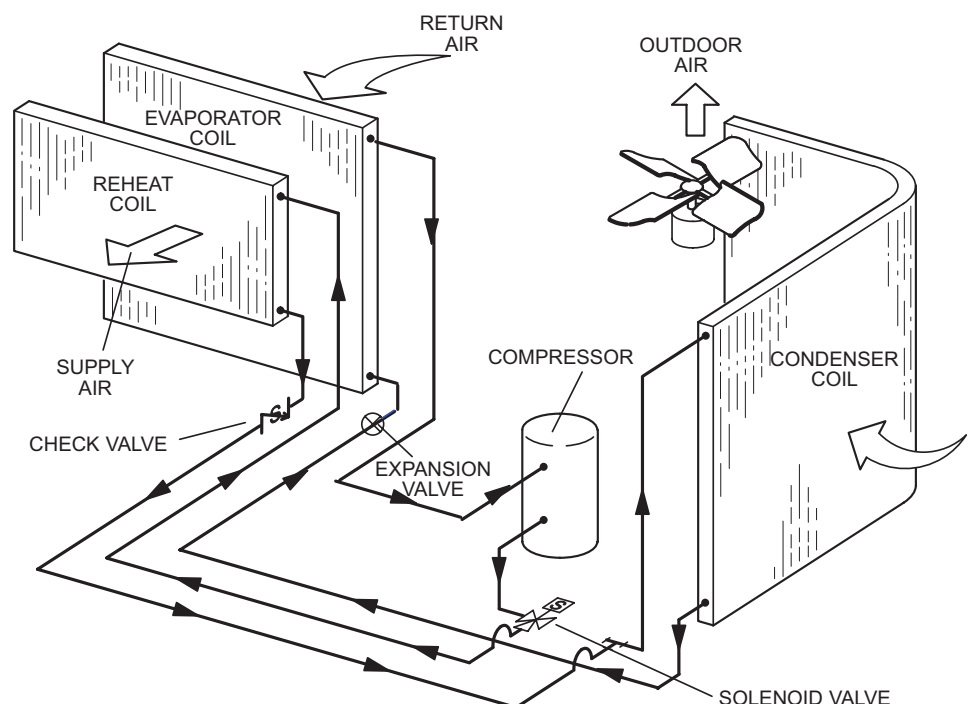

## OPTIONAL CONVENTIONAL TEMPERATURE CONTROL SYSTEMS

### CS8500 Commercial 7-Day Programmable Thermostat

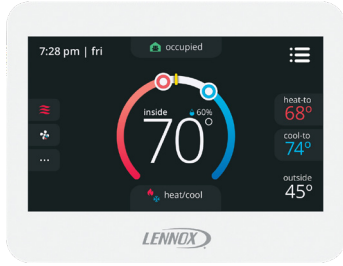

- Fully Communicating Sensor
- Full Color Touchscreen Interface
- Variable Speed System Control (On Compatible Units)
- Up To 4 Heat / 4 Cool
- Built-In Sensors For Temperature, Humidity And Optional CO<sub>2</sub>
- Remote Sensor Options For Occupancy, Temperature
- BACnet Capable Options
- 5-2 or 7-Day Scheduling
- Smooth Setback Recovery
- Heat/Cool Auto-Changeover
- Four-Wire Installation
- FDD, ASHRAE, IECC Compliant

### CS7500 Commercial 7-Day Programmable Thermostat



- Premium Universal Thermostat
- Full Color Touchscreen Interface
- Up To 4 Heat / 3 Cool
- Built-In Sensors For Temperature and Humidity
- Remote Sensors Options For Temperature, Discharge Air, Outdoor Air
- 5-2 or 7-Day Scheduling
- Smooth Setback Recovery
- Heat/Cool Auto-Changeover
- FDD, ASHRAE, IECC Compliant

### CS3000 Commercial 5-2 Day Programmable Thermostat



- Conventional Multi-Stage Thermostat
  - Intuitive Display
  - Push-Button Operation
  - Up To 2 Heat / 2 Cool
  - Built-In Temperature Sensor
  - Remote Temperature Sensing
  - Up to 5-2 Day Scheduling
  - Smooth Setback Recovery
  - Heat/Cool Auto-changeover
- Wired Temperature/Humidity Room Sensor (Non-Communicating)**



- Terminal blocks for wiring connections
- Five-wire sensor connection
- Off-white plastic enclosure
- Non-adjustable
- Relative humidity range: 0 -100%
- +/- 3% Accuracy

## OPTIONAL CONVENTIONAL TEMPERATURE CONTROL SYSTEMS

Description	Order Number
<b>CS8500 Commercial 7 Day Programmable Thermostat</b>	
CS8500 7-Day Thermostat	No CO <sub>2</sub> Sensing <b>24K55</b>
	With CO <sub>2</sub> Sensing <b>24K53</b>
Sensors/Accessories	<sup>1</sup> Remote non-adjustable wall-mount 10k <b>47W37</b>
	<sup>1</sup> Remote non-adjustable wall-mount 11k <b>94L61</b>
<b>Sysbus Network Cable (Yellow) for CS8500 and LCS-5030 Wired Room Sensor</b>	
Twisted pair 100% shielded communication cable, Red and Black	500 ft. box <b>27M19</b>
22 AWG, yellow jacket, rated at 75°C, 300V, Plenum rated	1000 ft. box <b>94L63</b>
Insulation - Low smoke PVC, NEC, CMP	2500 ft. roll <b>68M25</b>
<b>CS7500 Commercial 7-Day Programmable Thermostat</b>	
CS7500 7-Day Thermostat	<b>24K41</b>
Sensors/Accessories	<sup>2</sup> Remote non-adjustable wall-mount 20k <b>47W36</b>
	<sup>2</sup> Remote non-adjustable wall-mount 10k <b>47W37</b>
	Remote non-adjustable discharge air (duct mount) <b>19L22</b>
	Outdoor temperature sensor <b>X2658</b>
<b>CS3000 Commercial 5-2 Day Programmable Thermostat</b>	
CS3000 5-2 Day Thermostat	<b>11Y05</b>
Sensors/Accessories	Remote non-adjustable wall mount 10k averaging <b>47W37</b>
	Thermostat wall mounting plate <b>X2659</b>
<b>Universal Thermostat Guard with Lock (clear)</b>	
	Inside Dimensions (H x W x D) 5-7/8 x 8-3/8 x 3 in. <b>39P21</b>
<b>Temperature/Humidity Room Sensor</b>	
A335MT13AE1 Wired Temperature/Humidity Room Sensor (Non-Communicating)	<b>21W06</b>

<sup>1</sup> Up to nine of the same type remote temperature sensors can be connected in parallel.

<sup>2</sup> Remote wall-mount sensors can be applied in any of the following combinations:  
 One Sensor - (1) 47W36, Two Sensors - (2) 47W37, Three Sensors - (2) 47W36 and (1) 47W37  
 Four Sensors - (4) 47W36, Five Sensors - (3) 47W36 and (2) 47W37

## SEQUENCE OF OPERATION

**Objective:** Outline the unit functions as a result of room thermostat or zone sensor demands.

**Given:** When economizer is present, it will function as initial part of the unit cooling system. When not present, unit will function as if outdoor ambient is high and sensed as not suitable.

*NOTE: When the compressor is operating at first stage, the condenser fan is operating at low speed. The condenser fan switches to high speed when the compressor switches to second stage to match operation.*

### **Modulating Outdoor Air Damper:**

Damper minimum positions #1 and 2 are adjusted during unit setup to provide minimum fresh air requirements at the indicated supply fan speeds per ASHRAE 62.1.

- Supply fan is off and the outdoor air damper is closed
- Supply fan is on low speed and the outdoor air damper is at minimum position 1
- Supply fan is on high speed and the outdoor air damper is at minimum position 2

## **COOLING**

### **<sup>1</sup> Unit Features an Economizer and Outdoor Air is Suitable**

#### **Thermostat or Zone Sensor Mode (Up to 3 stages Y1, Y2, Y3)**

##### **Y1 Demand:**

Compressor is off, supply fan is on low speed, economizer modulates (minimum to maximum open position) to maintain 55°F supply air temperature (default unit controller setting)

After 5 minutes (default unit controller setting), supply fan switches to high speed. Economizer continues modulating with supply fan on high speed to maintain 55°F supply air temperature

##### **Y2 Demand:**

Compressor is off, supply fan is on high speed, and economizer modulates to maintain 55°F supply air temperature

Economizer opens to maximum. If economizer stays at maximum open for 3 minutes (default unit controller setting) compressor is energized and operates at first stage while supply fan stays on high speed

<sup>1</sup> Outdoor air suitability is determined by the energy state of outdoor ambient (enthalpy or sensible) and its ability to achieve the desired free cooling effects. Outdoor air suitability can also be determined by a third party controller and provided to the RTU via a network connection.

##### **Y3 Demand:**

Economizer is at maximum open and compressor operates at first stage. If economizer stays at maximum open for 3 minutes (default unit controller setting) compressor switches to second stage operation while supply fan stays on high speed

### **Unit Does Not Feature an Economizer (or Outdoor Air Is Not Suitable)**

#### **Thermostat or Zone Sensor (Up to 2 stages Y1, Y2)**

##### **Y1 Demand:**

Compressor operates at first stage and supply fan operates at low speed

##### **Y2 Demand:**

Compressor operates at second stage and supply fan operates at high speed

(Continued on Next Page)

## SEQUENCE OF OPERATION

### DEHUMIDIFICATION

**Unit Features the Humiditrol® Dehumidification option. Economizer free cooling is locked out**

**Dehumidification Demand, No demand for Y1, Y2**

Compressor operates at second stage, supply fan operates at low speed, and the reheat valve is energized

**Y1 Demand:**

Compressor operates at second stage, supply fan operates at low speed and the reheat valve is de-energized

**Y2 Demand:**

Compressor operates at second stage, supply fan operates at high speed, and the reheat valve is de-energized

### HEATING - TWO STAGE

**Two-Stage Heating Mode: Thermostat or Zone Sensor (Up to 2 stages W1, W2)**

**W1 Demand:**

Gas valve is open (stage 1 on units with 2 stage gas valve) and the supply fan operates at high speed

**W2 Demand:**

Gas valve is open (stage 2 on units with 2 stage gas valve) and the supply fan operates at high speed

### HEATING - MODULATING

**W1 or Low Heating Demand:**

Supply fan operates at low heating speed and gas valve modulates to maintain Discharge Air Temperature (DAT) setpoint

**W2 or High Heating Demand:**

Supply fan operates at high heating speed and gas valve modulates to maintain Discharge Air Temperature (DAT) setpoint

**Zone Sensor:**

Heating demand is based on delta and duration of Zone Air Temperature (ZAT) away from ZAT setpoint. Based on heating demand, supply fan modulates between low heating speed and high heating speed while gas valve modulates to maintain Discharge Air Temperature (DAT) setpoint as the blower speed changes

## OPTIONS / ACCESSORIES

Item	Order Number	Size				
		036	048	060	072	
<b>COOLING SYSTEM</b>						
Condensate Drain Trap	PVC	<b>22H54</b>	X	X	X	X
	Copper	<b>76W27</b>	X	X	X	X
Drain Pan Overflow Switch		<b>21Z07</b>	OX	OX	OX	OX
<b>HEATING SYSTEM</b>						
Bottom Gas Piping Kit		<b>19W50</b>	X	X	X	X
Combustion Air Intake Extensions		<b>19W51</b>	X	X	X	X
<sup>1</sup> Modulating Gas Heat		Factory	O	O	O	O
Gas Heat Input (Low NOx)	Standard - 53,000-65,000 Btuh input	Factory	O	O	O	O
	Medium - 81,000-108,000 Btuh input	Factory	O	O	O	O
	High - 113,000-150,000 Btuh input	Factory		O	O	O
LPG/Propane Conversion Kits	Standard Heat	<b>39H79</b>	X	X	X	X
	Medium and High Heat	<b>39H78</b>	X	X	X	X
Low Temperature Vestibule Heater	208/230V-1 or 3ph	<b>21Z17</b>	X	X	X	X
	460V-3ph	<b>21Z18</b>	X	X	X	X
	575V-3ph	<b>21Z19</b>	X	X	X	X
Stainless Steel Heat Exchanger		Factory	O	O	O	O
Vertical Vent Extension		<b>31W62</b>	X	X	X	X
<b>BLOWER - SUPPLY AIR</b>						
Motors - Standard Static (All voltages)	Direct Drive ECM Blower - 0.50 HP	Factory	O			
	1 HP	Factory		O	O	
Motors - High Static (3 phase only)	DirectPlus™ Direct Drive ECM Blower System - 1.5 HP	Factory	O	O	O	O
<b>CABINET</b>						
Burglar Bars		<b>Y1037</b>	X	X	X	X
Combination Coil/Hail Guards		<b>13T03</b>	OX	OX	OX	OX
Corrosion Protection		Factory	O	O	O	O
<b>CONTROLS</b>						
Blower Proving Switch		<b>21Z10</b>	OX	OX	OX	OX
Commercial Controls	LonTalk® Module	<b>54W27</b>	OX	OX	OX	OX
	Novar® LSE	Factory	O	O	O	O
Dirty Filter Switch		<b>53W66</b>	OX	OX	OX	OX
<sup>1</sup> Remote Discharge Air Temperature Sensor		<b>21Z08</b>	OX	OX	OX	OX
Fresh Air Tempering		<b>21Z08</b>	OX	OX	OX	OX
Smoke Detector - Supply or Return (Power board and one sensor)		<b>21Z11</b>	OX	OX	OX	OX
Smoke Detector - Supply and Return (Power board and two sensors)		<b>21Z12</b>	OX	OX	OX	OX

<sup>1</sup> Modulating Gas Heat for Horizontal Applications requires a Remote Discharge Air Temperature Sensor (21Z08). Sensor is shipped with the unit for field installation if unit is configured at the factory. Sensor must be ordered separately for field installation if unit is not factory configured.

NOTE - Order Numbers shown are for ordering field installed accessories.  
OX - Configure To Order (Factory Installed) or Field Installed  
O = Configure To Order (Factory Installed)  
X = Field Installed

## OPTIONS / ACCESSORIES

Item	Order Number	Size				
		036	048	060	072	
<b>ELECTRICAL</b>						
Voltage	208/230V - 1 phase	Factory	O	O	O	
60 Hz	208/230V - 3 phase	Factory	O	O	O	O
	460V - 3 phase	Factory	O	O	O	O
	575V - 3 phase	Factory	O	O	O	O
HACR Circuit Breakers		Factory	O	O	O	O
<sup>2</sup> Short-Circuit Current Rating (SCCR) of 100kA (includes Phase/Voltage Detection)		Factory	O	O	O	O
Disconnect Switch	80 amp	<b>22A25</b>	OX	OX	OX	OX
GFI Service	15 amp non-powered, field-wired (208/230V, 460V only)	<b>74M70</b>	OX	OX	OX	OX
Outlets	15 amp factory-wired and powered (208/230V, 460V only)	Factory	O	O	O	O
	<sup>3</sup> 20 amp non-powered, field-wired (208/230V, 460V, 575V)	<b>67E01</b>	X	X	X	X
	<sup>3</sup> 20 amp non-powered, field-wired (575V)	Factory	O	O	O	O
Weatherproof Cover for GFI		<b>10C89</b>	X	X	X	X
Phase/Voltage Detection - 3 Phase Models Only		Factory	O	O	O	O
<b>ECONOMIZER</b>						
<b>High Performance Economizer With Outdoor Air Hood (Sensible Control)</b> <b>(Approved for California Title 24 Building Standards / AMCA Class 1A Certified)</b>						
High Performance Economizer - Includes Barometric Relief Dampers and Combination Hood		<b>20H48</b>	OX	OX	OX	OX
High Performance Economizer - No Exhaust Option		Factory	O	O	O	O
<b>Economizer Accessories</b>						
Horizontal Economizer Conversion Kit		<b>17W45</b>	X	X	X	X
<b>Economizer Controls</b>						
Single Enthalpy (Not for Title 24)		<b>21Z09</b>	OX	OX	OX	OX
Differential Enthalpy (Not for Title 24)	Order 2	<b>21Z09</b>	OX	OX	OX	OX
Sensible Control	Sensor is Furnished	Factory	O	O	O	O
Outdoor Air CFM Control		<b>13J76</b>	X	X	X	X
Global Control	Sensor Field Provided	Factory	O	O	O	O
Building Pressure Control		<b>13J77</b>	X	X	X	X
<b>POWER EXHAUST FAN</b>						
Standard Static	208/230V-1 or 3ph	<b>21Z13</b>	OX	OX	OX	OX
<i>NOTE - Factory or Field installed Power Exhaust Fan requires "Barometric Relief Dampers for Power Exhaust Kit (21Z21)" for field installation.</i>	460V-3ph	<b>21Z14</b>	OX	OX	OX	OX
	575V-3ph	<b>21Z15</b>	OX	OX	OX	OX
<b>BAROMETRIC RELIEF</b>						
<sup>4</sup> Barometric Relief Dampers for Power Exhaust Kit		<b>21Z21</b>	X	X	X	X
<sup>5</sup> Horizontal Barometric Relief Dampers With Outdoor Air and Exhaust Hood		<b>19F01</b>	X	X	X	X
<b>OUTDOOR AIR</b>						
<b>Outdoor Air Dampers With Outdoor Air Hood</b>						
Motorized		<b>15D17</b>	OX	OX	OX	OX
Manual		<b>15D18</b>	X	X	X	X
<b>HUMIDITROL® CONDENSER REHEAT OPTION</b>						
Humiditrol® Dehumidification Option		Factory	O	O	O	O
Humidity Sensor Kit, Remote Mounted		<b>17M50</b>	X	X	X	X

<sup>2</sup> Disconnect Switch is furnished and factory installed with High SCCR option.

<sup>3</sup> Canada requires a minimum 20 amp circuit. Select 20 amp, non-powered, field wired GFI.

<sup>4</sup> Required when Economizer is factory installed with factory installed Power Exhaust Fan option.

<sup>5</sup> Required when Economizer is configured for horizontal airflow.

NOTE - Order Numbers shown are for ordering field installed accessories.

OX = Configure To Order (Factory Installed) or Field Installed

O = Configure To Order (Factory Installed)

X = Field Installed

## OPTIONS / ACCESSORIES

Item	Order Number	Size				
		036	048	060	072	
<b>INDOOR AIR QUALITY</b>						
<b>Air Filters</b>						
Healthy Climate® High Efficiency Air Filters 20 x 20 x 2 in. (Order 4 per unit)	MERV 8	<b>54W21</b>	OX	OX	OX	OX
	MERV 13	<b>52W39</b>	OX	OX	OX	OX
	MERV 16	<b>21U40</b>	X	X	X	X
Replaceable Media Filter With Metal Mesh Frame (includes non-pleated filter media) (order 4 per unit)	20 x 20 x 2 in.	<b>44N60</b>	X	X	X	X
<b>Indoor Air Quality (CO<sub>2</sub>) Sensors</b>						
Sensor - Wall-mount, off-white plastic cover with LCD display		<b>77N39</b>	X	X	X	X
Sensor - Wall-mount, off-white plastic cover, no display		<b>87N53</b>	X	X	X	X
Sensor - Black plastic case, LCD display, rated for plenum mounting		<b>87N52</b>	X	X	X	X
Sensor - Black plastic case, no display, rated for plenum mounting		<b>87N54</b>	X	X	X	X
CO <sub>2</sub> Sensor Duct Mounting Kit - for downflow applications		<b>23Y47</b>	X	X	X	X
Aspiration Box - for duct mounting non-plenum rated CO <sub>2</sub> sensors ( <b>77N39</b> )		<b>90N43</b>	X	X	X	X
<b>Needlepoint Bipolar Ionization (NPBI)</b>						
Needlepoint Bipolar Ionization (NPBI) Kit		<b>22U14</b>	X	X	X	X
<b>UVC Germicidal Lamps</b>						
<sup>6</sup> Healthy Climate® UVC Light Kit (110/230V-1ph)		<b>21A92</b>	X	X	X	X
Step-Down Transformers	460V primary, 230V secondary	<b>10H20</b>	X	X	X	X
	575V primary, 230V secondary	<b>10H21</b>	X	X	X	X
<b>ROOF CURBS</b>						
<b>Hybrid Roof Curbs, Downflow</b>						
8 in. height		<b>11F50</b>	X	X	X	X
14 in. height		<b>11F51</b>	X	X	X	X
18 in. height		<b>11F52</b>	X	X	X	X
24 in. height		<b>11F53</b>	X	X	X	X
<b>Adjustable Pitched Curb</b>						
14 in. height		<b>43W27</b>	X	X	X	X
<b>Transition Curb</b>						
Matches Enlight 036-072 Units to existing L Series® Curbs		<b>31B05</b>	X	X	X	X
<b>CEILING DIFFUSERS</b>						
Step-Down - Order one	RTD9-65S	<b>13K60</b>	X	X	X	
	RTD11-95S	<b>13K61</b>				X
Flush - Order one	FD9-65S	<b>13K55</b>	X	X	X	
	FD11-95S	<b>13K56</b>				X
Transitions (Supply and Return) - Order one	T1TRAN10AN1	<b>17W53</b>	X	X	X	
	T1TRAN20N-1	<b>17W54</b>				X

<sup>6</sup> Lamps operate on 110-230V single-phase power supply. Step-down transformer may be ordered separately for 460V and 575V units. Alternately, 110V power supply may be used to directly power the UVC ballast(s).

NOTE - Order Numbers shown are for ordering field installed accessories.

OX - Configure To Order (Factory Installed) or Field Installed

O = Configure To Order (Factory Installed)

X = Field Installed

SPECIFICATIONS					
<b>Model</b>		<b>LGT036H5E</b>	<b>LGT048H5E</b>	<b>LGT060H5E</b>	<b>LGT072H5E</b>
<b>Nominal Tonnage</b>		3	4	5	6
<b>Efficiency Type</b>		High	High	High	High
<b>Blower Type</b>		MSAV® ECM Direct Drive	MSAV® ECM Direct Drive	MSAV® ECM Direct Drive	MSAV® ECM Direct Drive
<b>Cooling Performance</b>	Gross Cooling Capacity (Btuh)	36,600	50,100	61,600	72,000
	<sup>1</sup> Net Cooling Capacity (Btuh)	36,000	49,000	60,000	69,000
	<sup>1</sup> AHRI Rated Air Flow (cfm-high/low)	1200/800	1600/1200	1800/1350	2000/1500
	<sup>1</sup> SEER2 (Btuh/Watt)	17.5	17.3	16.4	---
	<sup>1</sup> EER2 (Btuh/Watt)	13.5	13.0	12.5	---
	<sup>1</sup> IEER (Btuh/Watt)	---	---	---	17.3
	<sup>1</sup> EER (Btuh/Watt)	---	---	---	12.2
	Total Unit Power (kW)	2.7	3.8	4.6	5.6
<b>Sound Rating Number</b>	dBA	75	75	82	82
<b>Refrigerant Charge</b>	Refrigerant Type	R-454B	R-454B	R-454B	R-454B
	Without Reheat Option	4 lbs. 14 oz.	5 lbs. 2 oz.	4 lbs. 14 oz.	4 lbs. 13 oz.
	With Reheat Option	5 lbs. 6 oz.	5 lbs. 4 oz.	4 lbs. 13 oz.	4 lbs. 8 oz.
<b>Gas Heat Available</b>		See page 21			
<b>Compressor Type (Number)</b>		Two-Stage Scroll (1)			
<b>Outdoor Coil</b>	Net face area - ft. <sup>2</sup>	17.80	17.80	17.80	17.80
	Rows	1	1	1	1
	Fins - in.	20	20	20	20
<b>Outdoor Coil Fan</b>	Motor HP (number and type)	1/3 (1 ECM)	1/3 (1 ECM)	1/3 (1 ECM)	1/3 (1 ECM)
	Rpm	550-830	765-1010	830-1030	830-1030
	Watts	65-175	130-300	170-350	170-350
	Diameter (Number) - in.	(1) 24	(1) 24	(1) 24	(1) 24
	Blades	3	3	3	3
	Total air volume - cfm	2400 - 3795	2700 - 4100	3200 - 4700	3200 - 4700
<b>Indoor Coil</b>	Net face area - ft. <sup>2</sup>	8.65	8.65	8.65	8.65
	Rows	1	1	1	1
	Fins - in.	20	20	20	20
	Condensate drain size (NPT) - in.	(1) 1	(1) 1	(1) 1	(1) 1
	Expansion device type	Balanced Port Thermostatic Expansion Valve, removable power element			
<b>Indoor Blower</b>	Standard Blower type	Direct Drive ECM			
	Static Blade type (All Voltages)	Forward Curved			
	Nominal motor HP	0.50	1	1	---
	Wheel (Number) diameter x width - in.	(1) 10 X 10	(1) 11 X 10	(1) 11 X 10	---
	High Blower type	DirectPlus™ Direct Drive ECM			
	Static Blade type (3ph Only)	Backward Curved			
	Nominal motor HP	1.5	1.5	1.5	1.5
	Wheel (Number) diameter x width - in.	(1) 14 X 5	(1) 14 X 5	(1) 14 X 5	(1) 14 X 5
<b>Filters</b>	Type	MERV 4, Disposable			
	Number and size - in.	(4) 20 x 20 x 2			
<b>Line voltage data (Volts-Phase-Hz)</b>		208/230-1-60 208/230-3-60 460-3-60 575-3-60			208/230-3-60 460-3-60 575-3-60

NOTE - Net capacity includes evaporator blower motor heat deduction. Gross capacity does not include evaporator blower motor heat deduction.

<sup>1</sup> AHRI Certified to AHRI Standard 210/240 (3-5 ton) or 340/360 (6 ton): 95°F outdoor air temperature and 80°F db/67°F wb entering evaporator air; minimum external duct static pressure.

## SPECIFICATIONS

## LOW NOX GAS HEAT

Model		036, 048, 060	072	036, 048, 060, 072	048, 060, 072
<b>Gas Heat Input - Two-Stage or Modulating</b>		<b>Standard</b>		<b>Medium</b>	<b>High</b>
Input Btuh	Minimum	53,000		81,000	113,000
	Maximum	65,000		108,000	150,000
Output Btuh	Minimum	43,000		66,000	92,000
	Maximum	52,000		87,000	121,000
Temperature Rise Range - °F	Minimum	5-35		25 - 55	30 - 60
	Maximum	15-45 (0.5, 1 and 1.5 HP)	10-40 (1.5 HP)	30 - 70	45 - 75
Minimum air volume - cfm		960 (0.5 and 1 HP) 1075 (1.5 HP)	1075 (1.5 HP)	1150	1500
<sup>1</sup> AFUE (Single Phase)		81%		81%	81%
<sup>2</sup> Thermal Efficiency (Three Phase)		81%		81%	81%
Gas Supply Connections		1/2 in. NPT			
Recommended Gas Supply Pressure - Nat. / LPG		7 in. w.g. / 11 in. w.g.			
Gas Supply Pressure Range	Min./Max. (Natural)	4.5 - 10.5 in. w.g.			
	Min./Max. (LPG)	10.8 - 13.5 in. w.g.			

NOTE - Modulating Gas Heat operates between the minimum and maximum gas heat inputs shown.

NOTE - Air volume may modulate below minimum volume if heat input is below maximum.

<sup>1</sup> Annual Fuel Utilization Efficiency based on U.S. DOE test procedures and FTC labeling regulations.

<sup>2</sup> Thermal Efficiency at full input.

## HIGH ALTITUDE DERATE

**NOTE** - Units may be installed at altitudes up to 2000 feet above sea level without any modifications.

At altitudes above 2000 feet units must be derated to match gas manifold pressures shown in table below.

At altitudes above 4500 feet unit must be derated 2% for each 1000 feet above sea level.

**NOTE** - This is the only permissible derate for these units.

Refer to the Installation Instructions for more detailed information.

Heat Input Type	Altitude Feet	Gas Manifold Pressure in. w.g.		Input Rate (Btuh)
		Natural Gas	LPG/ Propane	
Standard	2001 - 4500	1.7 / 3.0	5.1 / 9.0	49,000 - 60,000
Medium	2001 - 4500	1.7 / 3.0	5.1 / 9.0	75,000 - 100,000
High	2001 - 4500	1.7 / 3.0	5.1 / 9.0	104,000 - 139,000

# RATINGS

NOTE - For Temperatures and Capacities not shown in tables, see bulletin - Cooling Unit Rating Table Correction Factor Data in Miscellaneous Product Data section.

## 3 TON - LGT036H5 (PART LOAD)

Entering Wet Bulb Temperature	Total Air Volume	Outdoor Air Temperature Entering Outdoor Coil																			
		65°F					75°F					85°F					95°F				
		Total Cool Cap.	Comp. Motor Input	Sensible To Total Ratio (S/T)			Total Cool Cap.	Comp. Motor Input	Sensible To Total Ratio (S/T)			Total Cool Cap.	Comp. Motor Input	Sensible To Total Ratio (S/T)			Total Cool Cap.	Comp. Motor Input	Sensible To Total Ratio (S/T)		
				Dry Bulb					Dry Bulb					Dry Bulb					Dry Bulb		
cfm	kBtuh	kW	75°F	80°F	85°F	kBtuh	kW	75°F	80°F	85°F	kBtuh	kW	75°F	80°F	85°F	kBtuh	kW	75°F	80°F	85°F	
63°F	640	25.8	1.11	0.63	0.75	0.91	24.8	1.28	0.64	0.77	0.93	23.6	1.47	0.65	0.79	0.97	22.4	1.68	0.66	0.82	1
	800	27.4	1.1	0.67	0.84	1	26.3	1.27	0.68	0.87	1	25.1	1.46	0.7	0.9	1	23.8	1.66	0.72	0.93	1
	960	28.6	1.09	0.72	0.94	1	27.5	1.26	0.74	0.97	1	26.3	1.45	0.77	1	1	25	1.65	0.8	1	1
67°F	640	27.6	1.09	0.5	0.6	0.71	26.5	1.27	0.5	0.61	0.73	25.4	1.45	0.51	0.62	0.75	24.1	1.66	0.52	0.63	0.77
	800	29.2	1.08	0.52	0.64	0.79	28	1.25	0.53	0.66	0.82	26.8	1.44	0.54	0.67	0.85	25.4	1.65	0.55	0.69	0.88
	960	30.4	1.07	0.55	0.69	0.89	29.1	1.25	0.56	0.71	0.92	27.8	1.43	0.57	0.73	0.95	26.3	1.64	0.58	0.76	0.99
71°F	640	29.5	1.08	0.39	0.48	0.58	28.4	1.25	0.39	0.49	0.58	27.2	1.44	0.39	0.49	0.59	25.8	1.64	0.39	0.5	0.61
	800	31.3	1.07	0.4	0.51	0.62	30	1.24	0.4	0.51	0.63	28.7	1.43	0.4	0.52	0.64	27.2	1.63	0.4	0.53	0.66
	960	32.4	1.06	0.41	0.54	0.67	31.1	1.23	0.41	0.54	0.68	29.7	1.42	0.41	0.56	0.7	28.2	1.63	0.42	0.57	0.73

## 3 TON - LGT036H5 (FULL LOAD)

Entering Wet Bulb Temperature	Total Air Volume	Outdoor Air Temperature Entering Outdoor Coil																			
		85°F					95°F					105°F					115°F				
		Total Cool Cap.	Comp. Motor Input	Sensible To Total Ratio (S/T)			Total Cool Cap.	Comp. Motor Input	Sensible To Total Ratio (S/T)			Total Cool Cap.	Comp. Motor Input	Sensible To Total Ratio (S/T)			Total Cool Cap.	Comp. Motor Input	Sensible To Total Ratio (S/T)		
				Dry Bulb					Dry Bulb					Dry Bulb					Dry Bulb		
cfm	kBtuh	kW	75°F	80°F	85°F	kBtuh	kW	75°F	80°F	85°F	kBtuh	kW	75°F	80°F	85°F	kBtuh	kW	75°F	80°F	85°F	
63°F	960	34.6	2.1	0.68	0.82	0.98	33	2.37	0.69	0.84	1	31.3	2.66	0.7	0.87	1	29.4	3.02	0.72	0.91	1
	1200	36.6	2.11	0.73	0.92	1	34.8	2.38	0.75	0.95	1	33.1	2.67	0.77	0.99	1	31.2	3.02	0.8	1	1
	1440	38.3	2.13	0.8	1	1	36.7	2.39	0.82	1	1	35	2.69	0.85	1	1	33.2	3.04	0.9	1	1
67°F	960	37	2.12	0.53	0.65	0.78	35.3	2.38	0.54	0.66	0.8	33.4	2.68	0.55	0.68	0.83	31.5	3.02	0.56	0.7	0.86
	1200	38.9	2.13	0.56	0.7	0.87	37	2.39	0.57	0.72	0.91	35	2.69	0.58	0.74	0.94	32.9	3.04	0.6	0.77	0.98
	1440	40.2	2.14	0.6	0.77	0.97	38.4	2.41	0.61	0.79	1	36.2	2.7	0.62	0.83	1	34	3.04	0.64	0.86	1
71°F	960	39.6	2.14	0.41	0.52	0.62	37.8	2.4	0.41	0.52	0.64	35.8	2.7	0.41	0.53	0.65	33.7	3.04	0.42	0.54	0.67
	1200	41.6	2.16	0.42	0.55	0.68	39.6	2.42	0.42	0.56	0.7	37.5	2.71	0.43	0.57	0.72	35.2	3.06	0.43	0.59	0.74
	1440	43	2.17	0.43	0.58	0.74	40.9	2.43	0.44	0.6	0.76	38.6	2.73	0.44	0.61	0.8	36.2	3.07	0.45	0.63	0.84

## 4 TON - LGT048H5 (PART LOAD)

Entering Wet Bulb Temperature	Total Air Volume	Outdoor Air Temperature Entering Outdoor Coil																			
		65°F					75°F					85°F					95°F				
		Total Cool Cap.	Comp. Motor Input	Sensible To Total Ratio (S/T)			Total Cool Cap.	Comp. Motor Input	Sensible To Total Ratio (S/T)			Total Cool Cap.	Comp. Motor Input	Sensible To Total Ratio (S/T)			Total Cool Cap.	Comp. Motor Input	Sensible To Total Ratio (S/T)		
				Dry Bulb					Dry Bulb					Dry Bulb					Dry Bulb		
cfm	kBtuh	kW	75°F	80°F	85°F	kBtuh	kW	75°F	80°F	85°F	kBtuh	kW	75°F	80°F	85°F	kBtuh	kW	75°F	80°F	85°F	
63°F	850	35.6	1.41	0.77	0.88	0.96	34.1	1.66	0.78	0.89	0.97	32.6	1.95	0.79	0.9	0.99	30.9	2.27	0.81	0.92	1
	1065	37.8	1.39	0.82	0.93	1	36.2	1.64	0.83	0.94	1	34.6	1.93	0.85	0.95	1	32.7	2.26	0.86	0.97	1
	1280	39.5	1.38	0.86	0.97	1	37.8	1.63	0.87	0.99	1	36.2	1.92	0.89	1	1	34.5	2.24	0.9	1	1
67°F	850	38	1.39	0.61	0.74	0.85	36.5	1.64	0.62	0.75	0.86	34.9	1.93	0.62	0.76	0.88	33.2	2.25	0.63	0.77	0.89
	1065	40.2	1.37	0.64	0.79	0.9	38.6	1.62	0.65	0.8	0.92	36.9	1.91	0.66	0.82	0.93	35	2.24	0.67	0.84	0.95
	1280	41.8	1.35	0.67	0.84	0.95	40.1	1.61	0.68	0.86	0.96	38.3	1.9	0.7	0.87	0.98	36.3	2.23	0.71	0.89	1
71°F	850	40.7	1.37	0.48	0.59	0.7	39.1	1.62	0.48	0.6	0.71	37.5	1.9	0.48	0.6	0.73	35.6	2.23	0.48	0.61	0.74
	1065	43	1.34	0.49	0.62	0.76	41.3	1.59	0.49	0.63	0.77	39.5	1.89	0.49	0.64	0.79	37.5	2.22	0.49	0.65	0.81
	1280	44.6	1.32	0.5	0.66	0.82	42.9	1.58	0.5	0.67	0.84	40.9	1.87	0.51	0.68	0.85	38.9	2.2	0.51	0.7	0.87

## 4 TON - LGT048H5 (FULL LOAD)

Entering Wet Bulb Temperature	Total Air Volume	Outdoor Air Temperature Entering Outdoor Coil																			
		85°F					95°F					105°F					115°F				
		Total Cool Cap.	Comp. Motor Input	Sensible To Total Ratio (S/T)			Total Cool Cap.	Comp. Motor Input	Sensible To Total Ratio (S/T)			Total Cool Cap.	Comp. Motor Input	Sensible To Total Ratio (S/T)			Total Cool Cap.	Comp. Motor Input	Sensible To Total Ratio (S/T)		
				Dry Bulb					Dry Bulb					Dry Bulb					Dry Bulb		
cfm	kBtuh	kW	75°F	80°F	85°F	kBtuh	kW	75°F	80°F	85°F	kBtuh	kW	75°F	80°F	85°F	kBtuh	kW	75°F	80°F	85°F	
63°F	1280	46.9	2.72	0.68	0.83	0.98	44.7	3.06	0.7	0.85	1	42.4	3.45	0.71	0.88	1	39.9	3.91	0.73	0.91	1
	1600	49.4	2.74	0.74	0.92	1	47.2	3.08	0.76	0.95	1	44.7	3.47	0.78	0.99	1	42.3	3.92	0.81	1	1
	1920	51.7	2.75	0.8	1	1	49.5	3.09	0.83	1	1	47.2	3.48	0.86	1	1	44.7	3.93	0.89	1	1
67°F	1280	49.9	2.74	0.54	0.66	0.79	47.6	3.08	0.55	0.67	0.81	45.1	3.47	0.56	0.69	0.84	42.5	3.92	0.57	0.7	0.87
	1600	52.4	2.76	0.57	0.71	0.88	49.9	3.09	0.58	0.73	0.91	47.1	3.48	0.59	0.75	0.95	44.4	3.92	0.61	0.78	0.99
	1920	54.1	2.77	0.6	0.78	0.98	51.5	3.11	0.62	0.8	1	48.7	3.49	0.63	0.83	1	45.7	3.93	0.65	0.87	1
71°F	1280	53.2	2.76	0.41	0.52	0.63	50.8	3.1	0.41	0.53	0.65	48.2	3.49	0.42	0.54	0.66	45.4	3.93	0.42	0.55	0.68
	1600	55.8	2.78	0.42	0.56	0.69	53.2	3.12	0.43	0.57	0.71	50.2	3.5	0.43	0.58	0.73	47.2	3.93	0.44	0.59	0.75
	1920	57.5	2.79	0.44	0.59	0.75	54.7	3.13	0.44	0.61	0.78	51.7	3.5	0.45	0.62	0.81	48.5	3.94	0.46	0.64	0.84

# RATINGS

NOTE - For Temperatures and Capacities not shown in tables, see bulletin - Cooling Unit Rating Table Correction Factor Data in Miscellaneous Product Data section.

## 5 TON - LGT060H5 (PART LOAD)

Entering Wet Bulb Temperature	Total Air Volume	Outdoor Air Temperature Entering Outdoor Coil																			
		65°F					75°F					85°F					95°F				
		Total Cool Cap.	Comp. Motor Input	Sensible To Total Ratio (S/T)			Total Cool Cap.	Comp. Motor Input	Sensible To Total Ratio (S/T)			Total Cool Cap.	Comp. Motor Input	Sensible To Total Ratio (S/T)			Total Cool Cap.	Comp. Motor Input	Sensible To Total Ratio (S/T)		
				Dry Bulb					Dry Bulb					Dry Bulb					Dry Bulb		
cfm	kBtuh	kW	75°F	80°F	85°F	kBtuh	kW	75°F	80°F	85°F	kBtuh	kW	75°F	80°F	85°F	kBtuh	kW	75°F	80°F	85°F	
63°F	1070	47	1.78	0.64	0.77	0.93	45	2.07	0.65	0.79	0.96	42.7	2.38	0.67	0.82	0.99	40.1	2.74	0.68	0.85	1
	1335	49.8	1.77	0.69	0.86	1	47.6	2.05	0.7	0.89	1	45.1	2.38	0.72	0.93	1	42.5	2.73	0.75	0.97	1
	1600	52	1.76	0.74	0.96	1	49.9	2.05	0.76	0.99	1	47.4	2.37	0.79	1	1	45	2.73	0.83	1	1
67°F	1070	50.3	1.77	0.51	0.62	0.73	48.2	2.05	0.52	0.63	0.75	45.7	2.37	0.52	0.64	0.77	43	2.73	0.53	0.66	0.8
	1335	53.1	1.75	0.54	0.66	0.81	50.8	2.04	0.55	0.68	0.84	48.1	2.37	0.55	0.69	0.88	45.1	2.73	0.57	0.71	0.92
	1600	55.1	1.74	0.57	0.71	0.91	52.7	2.03	0.58	0.73	0.94	49.8	2.36	0.59	0.76	0.98	46.8	2.72	0.6	0.8	1
71°F	1070	53.9	1.75	0.4	0.49	0.59	51.6	2.04	0.4	0.5	0.6	49	2.36	0.4	0.51	0.62	46.1	2.72	0.4	0.52	0.63
	1335	56.8	1.73	0.4	0.52	0.64	54.3	2.03	0.41	0.53	0.65	51.4	2.35	0.41	0.54	0.67	48.3	2.72	0.42	0.55	0.69
	1600	58.8	1.72	0.42	0.55	0.69	56.1	2.02	0.42	0.56	0.71	53.1	2.35	0.42	0.58	0.73	49.9	2.71	0.43	0.59	0.76

## 5 TON - LGT060H5 (FULL LOAD)

Entering Wet Bulb Temperature	Total Air Volume	Outdoor Air Temperature Entering Outdoor Coil																			
		85°F					95°F					105°F					115°F				
		Total Cool Cap.	Comp. Motor Input	Sensible To Total Ratio (S/T)			Total Cool Cap.	Comp. Motor Input	Sensible To Total Ratio (S/T)			Total Cool Cap.	Comp. Motor Input	Sensible To Total Ratio (S/T)			Total Cool Cap.	Comp. Motor Input	Sensible To Total Ratio (S/T)		
				Dry Bulb					Dry Bulb					Dry Bulb					Dry Bulb		
cfm	kBtuh	kW	75°F	80°F	85°F	kBtuh	kW	75°F	80°F	85°F	kBtuh	kW	75°F	80°F	85°F	kBtuh	kW	75°F	80°F	85°F	
63°F	1600	59.2	3.43	0.7	0.85	1	56.7	3.82	0.71	0.87	1	54	4.29	0.72	0.9	1	51	4.83	0.74	0.93	1
	2000	62.5	3.46	0.75	0.95	1	59.6	3.86	0.78	0.98	1	56.9	4.32	0.8	1	1	54.1	4.86	0.83	1	1
	2400	65.5	3.5	0.83	1	1	62.9	3.9	0.85	1	1	60.1	4.37	0.88	1	1	57.1	4.91	0.92	1	1
67°F	1600	63	3.47	0.55	0.67	0.81	60.2	3.87	0.56	0.69	0.83	57.3	4.33	0.57	0.7	0.86	54	4.86	0.58	0.72	0.89
	2000	66	3.51	0.58	0.73	0.91	63	3.9	0.59	0.75	0.94	59.8	4.36	0.6	0.77	0.97	56.4	4.9	0.62	0.8	1
	2400	68.1	3.54	0.62	0.8	1	65.1	3.93	0.63	0.82	1	61.7	4.39	0.65	0.85	1	58.1	4.92	0.66	0.89	1
71°F	1600	67.3	3.53	0.42	0.53	0.65	64.2	3.92	0.42	0.54	0.66	61	4.38	0.42	0.55	0.68	57.6	4.92	0.43	0.56	0.7
	2000	70.4	3.57	0.43	0.57	0.71	67	3.96	0.43	0.58	0.72	63.6	4.42	0.44	0.59	0.74	59.9	4.95	0.44	0.61	0.77
	2400	72.4	3.6	0.45	0.61	0.77	69	3.99	0.45	0.62	0.8	65.3	4.45	0.46	0.64	0.83	61.6	4.97	0.46	0.65	0.87

## 6 TON - LGT072H5 (PART LOAD)

Entering Wet Bulb Temperature	Total Air Volume	Outdoor Air Temperature Entering Outdoor Coil																			
		65°F					75°F					85°F					95°F				
		Total Cool Cap.	Comp. Motor Input	Sensible To Total Ratio (S/T)			Total Cool Cap.	Comp. Motor Input	Sensible To Total Ratio (S/T)			Total Cool Cap.	Comp. Motor Input	Sensible To Total Ratio (S/T)			Total Cool Cap.	Comp. Motor Input	Sensible To Total Ratio (S/T)		
				Dry Bulb					Dry Bulb					Dry Bulb					Dry Bulb		
cfm	kBtuh	kW	75°F	80°F	85°F	kBtuh	kW	75°F	80°F	85°F	kBtuh	kW	75°F	80°F	85°F	kBtuh	kW	75°F	80°F	85°F	
63°F	1200	51.8	2.25	0.65	0.77	0.92	49.9	2.59	0.65	0.78	0.94	47.8	2.98	0.66	0.8	0.97	45.4	3.41	0.68	0.83	0.99
	1600	56.1	2.25	0.7	0.88	1	53.9	2.59	0.71	0.9	1	51.5	2.98	0.73	0.93	1	48.9	3.41	0.75	0.97	1
	2000	59.3	2.24	0.77	0.99	1	57.2	2.58	0.79	1	1	54.9	2.97	0.82	1	1	52.4	3.41	0.85	1	1
67°F	1200	55.6	2.25	0.52	0.62	0.72	53.5	2.59	0.52	0.63	0.74	51.2	2.98	0.53	0.64	0.76	48.7	3.41	0.53	0.65	0.78
	1600	59.9	2.24	0.55	0.68	0.83	57.3	2.58	0.56	0.69	0.85	54.8	2.97	0.56	0.7	0.88	51.9	3.41	0.57	0.72	0.92
	2000	62.8	2.23	0.58	0.74	0.95	60.1	2.58	0.59	0.76	0.97	57.3	2.97	0.61	0.79	1	54.2	3.4	0.62	0.82	1
71°F	1200	59.8	2.24	0.4	0.5	0.59	57.5	2.58	0.4	0.5	0.6	55	2.97	0.4	0.51	0.61	52.2	3.41	0.41	0.52	0.62
	1600	64.2	2.22	0.41	0.53	0.65	61.5	2.57	0.41	0.54	0.66	58.7	2.96	0.42	0.55	0.68	55.6	3.4	0.42	0.56	0.7
	2000	67.1	2.21	0.43	0.57	0.71	64.2	2.56	0.43	0.58	0.73	61.1	2.95	0.43	0.59	0.76	57.8	3.39	0.44	0.61	0.79

## 6 TON - LGT072H5 (FULL LOAD)

Entering Wet Bulb Temperature	Total Air Volume	Outdoor Air Temperature Entering Outdoor Coil																			
		85°F					95°F					105°F					115°F				
		Total Cool Cap.	Comp. Motor Input	Sensible To Total Ratio (S/T)			Total Cool Cap.	Comp. Motor Input	Sensible To Total Ratio (S/T)			Total Cool Cap.	Comp. Motor Input	Sensible To Total Ratio (S/T)			Total Cool Cap.	Comp. Motor Input	Sensible To Total Ratio (S/T)		
				Dry Bulb					Dry Bulb					Dry Bulb					Dry Bulb		
cfm	kBtuh	kW	75°F	80°F	85°F	kBtuh	kW	75°F	80°F	85°F	kBtuh	kW	75°F	80°F	85°F	kBtuh	kW	75°F	80°F	85°F	
63°F	1920	69.9	4.22	0.72	0.86	1	66.6	4.77	0.73	0.89	1	63.3	5.39	0.75	0.92	1	59.5	6.1	0.77	0.95	1
	2400	73.7	4.26	0.77	0.96	1	70.3	4.81	0.8	0.98	1	66.9	5.43	0.82	1	1	63.3	6.14	0.85	1	1
	2880	77.4	4.31	0.84	1	1	74	4.85	0.87	1	1	70.5	5.47	0.9	1	1	66.7	6.18	0.94	1	1
67°F	1920	74.3	4.27	0.56	0.69	0.82	70.7	4.81	0.57	0.71	0.85	67.1	5.43	0.58	0.72	0.88	63.1	6.14	0.59	0.74	0.91
	2400	77.9	4.31	0.6	0.75	0.92	73.9	4.85	0.61	0.77	0.95	69.8	5.46	0.62	0.8	0.99	65.7	6.17	0.64	0.83	1
	2880	80.4	4.34	0.64	0.82	1	76.4	4.88	0.65	0.84	1	72.2	5.49	0.67	0.88	1	67.6	6.19	0.68	0.92	1
71°F	1920	79.4	4.33	0.43	0.55	0.67	75.5	4.87	0.43	0.56	0.68	71.4	5.48	0.43	0.57	0.7	67.1	6.18	0.44	0.58	0.72
	2400	82.7	4.37	0.44	0.58	0.73	78.6	4.92	0.45	0.6	0.75	74.4	5.53	0.45	0.61	0.77	69.5	6.21	0.46	0.63	0.8
	2880	85.1	4.4	0.46	0.62	0.79	80.8	4.95	0.46	0.64	0.82	76.3	5.55	0.47	0.66	0.85	71.5	6.24	0.48	0.68	0.89

# HUMIDITROL® DEHUMIDIFICATION SYSTEM RATINGS

## 3 TON - LGT036H5 WITH HUMIDITROL® OPERATING

Entering Wet Bulb Temperature	Total Air Volume	Outdoor Air Temperature Entering Outdoor Coil																			
		65°F					75°F					85°F					95°F				
		Total Cool Cap.	Comp. Motor Input	Sensible To Total Ratio (S/T)			Total Cool Cap.	Comp. Motor Input	Sensible To Total Ratio (S/T)			Total Cool Cap.	Comp. Motor Input	Sensible To Total Ratio (S/T)			Total Cool Cap.	Comp. Motor Input	Sensible To Total Ratio (S/T)		
				Dry Bulb					Dry Bulb					Dry Bulb					Dry Bulb		
cfm	kBtuh	kW	75°F	80°F	85°F	kBtuh	kW	75°F	80°F	85°F	kBtuh	kW	75°F	80°F	85°F	kBtuh	kW	75°F	80°F	85°F	
63°F	640	22.2	1.58	0.40	0.54	0.69	18.0	1.70	0.31	0.49	0.67	13.8	1.86	0.17	0.41	0.64	9.7	2.07	-0.08	0.27	0.60
	800	23.9	1.62	0.43	0.60	0.77	19.5	1.72	0.34	0.57	0.77	14.1	1.90	0.19	0.49	0.77	9.3	2.10	-0.11	0.34	0.78
	950	24.9	1.66	0.47	0.67	0.86	19.4	1.78	0.38	0.63	0.88	13.8	1.93	0.21	0.57	0.91	8.5	2.13	-0.15	0.45	0.97
67°F	640	25.8	1.62	0.28	0.40	0.52	21.5	1.75	0.18	0.33	0.48	17.3	1.90	0.04	0.23	0.41	13.2	2.11	-0.19	0.07	0.31
	800	27.9	1.67	0.29	0.43	0.58	22.9	1.79	0.18	0.36	0.54	17.9	1.95	0.02	0.26	0.49	13.1	2.14	-0.25	0.07	0.39
	950	29.3	1.70	0.31	0.48	0.64	23.5	1.83	0.19	0.40	0.61	17.9	1.98	0.01	0.29	0.56	12.5	2.17	-0.32	0.08	0.48
71°F	640	29.5	1.67	0.17	0.28	0.40	25.3	1.79	0.08	0.21	0.34	21.0	1.95	-0.06	0.10	0.26	16.9	2.15	-0.25	-0.05	0.14
	800	32.0	1.72	0.18	0.31	0.44	26.9	1.84	0.07	0.22	0.38	21.9	1.99	-0.09	0.10	0.29	17.1	2.18	-0.32	-0.08	0.17
	950	33.2	1.77	0.18	0.32	0.47	27.8	1.87	0.06	0.24	0.42	22.3	2.01	-0.11	0.12	0.34	16.7	2.21	-0.40	-0.10	0.19

NOTE - Total Cooling Capacity is calculated at 80°F Dry Bulb.

## 4 TON - LGT048H5 WITH HUMIDITROL® OPERATING

Entering Wet Bulb Temperature	Total Air Volume	Outdoor Air Temperature Entering Outdoor Coil																			
		65°F					75°F					85°F					95°F				
		Total Cool Cap.	Comp. Motor Input	Sensible To Total Ratio (S/T)			Total Cool Cap.	Comp. Motor Input	Sensible To Total Ratio (S/T)			Total Cool Cap.	Comp. Motor Input	Sensible To Total Ratio (S/T)			Total Cool Cap.	Comp. Motor Input	Sensible To Total Ratio (S/T)		
				Dry Bulb					Dry Bulb					Dry Bulb					Dry Bulb		
cfm	kBtuh	kW	75°F	80°F	85°F	kBtuh	kW	75°F	80°F	85°F	kBtuh	kW	75°F	80°F	85°F	kBtuh	kW	75°F	80°F	85°F	
63°F	960	26.1	2.11	0.41	0.59	0.78	20.1	2.27	0.29	0.54	0.78	14.0	2.47	0.07	0.43	0.78	8.3	2.71	-0.43	0.19	0.78
	1200	27.8	2.16	0.46	0.68	0.90	20.9	2.32	0.34	0.64	0.93	13.9	2.52	0.10	0.56	1.00	6.9	2.79	-0.59	0.33	1.00
	1440	28.7	2.20	0.51	0.77	1.00	21.0	2.36	0.40	0.76	1.00	12.9	2.57	0.15	0.73	1.00	5.4	2.81	-0.85	0.65	1.00
67°F	960	31.0	2.17	0.25	0.41	0.57	24.9	2.33	0.12	0.32	0.52	19.0	2.53	-0.09	0.18	0.44	12.9	2.80	-0.49	-0.11	0.29
	1200	33.0	2.22	0.27	0.46	0.65	26.0	2.38	0.13	0.37	0.61	18.9	2.58	-0.11	0.22	0.55	12.0	2.83	-0.63	-0.09	0.43
	1440	34.2	2.26	0.30	0.52	0.73	26.3	2.42	0.14	0.43	0.72	18.4	2.62	-0.14	0.28	0.69	10.5	2.87	-0.83	-0.09	0.62
71°F	960	36.1	2.22	0.13	0.27	0.41	30.0	2.39	0.00	0.17	0.34	23.9	2.59	-0.19	0.02	0.23	17.9	2.84	-0.52	-0.22	0.06
	1200	38.5	2.28	0.13	0.29	0.46	31.3	2.45	-0.01	0.19	0.39	24.2	2.65	-0.24	0.02	0.28	17.2	2.90	-0.65	-0.28	0.09
	1440	39.9	2.31	0.13	0.32	0.51	31.9	2.49	-0.02	0.21	0.45	23.9	2.69	-0.29	0.02	0.34	16.0	2.94	-0.82	-0.34	0.14

NOTE - Total Cooling Capacity is calculated at 80°F Dry Bulb.

## 5 TON - LGT060H5 WITH HUMIDITROL® OPERATING

Entering Wet Bulb Temperature	Total Air Volume	Outdoor Air Temperature Entering Outdoor Coil																			
		65°F					75°F					85°F					95°F				
		Total Cool Cap.	Comp. Motor Input	Sensible To Total Ratio (S/T)			Total Cool Cap.	Comp. Motor Input	Sensible To Total Ratio (S/T)			Total Cool Cap.	Comp. Motor Input	Sensible To Total Ratio (S/T)			Total Cool Cap.	Comp. Motor Input	Sensible To Total Ratio (S/T)		
				Dry Bulb					Dry Bulb					Dry Bulb					Dry Bulb		
cfm	kBtuh	kW	75°F	80°F	85°F	kBtuh	kW	75°F	80°F	85°F	kBtuh	kW	75°F	80°F	85°F	kBtuh	kW	75°F	80°F	85°F	
63°F	1080	31.8	2.86	0.34	0.52	0.70	25.5	3.04	0.23	0.45	0.67	19.2	3.28	0.05	0.34	0.63	12.9	3.60	-0.32	0.13	0.57
	1350	34.0	2.95	0.39	0.59	0.80	26.6	3.13	0.27	0.54	0.80	19.0	3.37	0.06	0.44	0.80	11.4	3.70	-0.42	0.21	0.81
	1620	35.2	3.02	0.43	0.67	0.91	26.8	3.20	0.31	0.63	0.93	18.2	3.44	0.09	0.56	0.98	9.7	3.77	-0.56	0.35	1.00
67°F	1080	37.6	2.95	0.20	0.35	0.50	31.1	3.13	0.08	0.26	0.44	24.6	3.37	-0.10	0.13	0.36	18.2	3.71	-0.41	-0.09	0.22
	1350	40.2	3.05	0.22	0.39	0.57	32.6	3.23	0.09	0.31	0.52	24.9	3.47	-0.13	0.16	0.45	17.3	3.80	-0.52	-0.11	0.31
	1620	41.7	3.13	0.24	0.44	0.64	33.1	3.31	0.09	0.35	0.61	24.4	3.55	-0.15	0.20	0.55	15.7	3.87	-0.66	-0.11	0.43
71°F	1080	43.6	3.05	0.09	0.22	0.35	37.0	3.23	-0.02	0.13	0.28	30.4	3.48	-0.19	-0.01	0.18	23.8	3.81	-0.45	-0.21	0.03
	1350	46.6	3.16	0.09	0.24	0.39	38.9	3.34	-0.04	0.14	0.32	31.1	3.59	-0.24	-0.01	0.22	23.3	3.91	-0.57	-0.26	0.04
	1620	48.6	3.25	0.09	0.27	0.44	39.8	3.43	-0.06	0.16	0.37	30.9	3.67	-0.29	-0.01	0.26	22.1	3.99	-0.71	-0.32	0.07

NOTE - Total Cooling Capacity is calculated at 80°F Dry Bulb.

## 6 TON - LGT072H5 WITH HUMIDITROL® OPERATING

Entering Wet Bulb Temperature	Total Air Volume	Outdoor Air Temperature Entering Outdoor Coil																			
		65°F					75°F					85°F					95°F				
		Total Cool Cap.	Comp. Motor Input	Sensible To Total Ratio (S/T)			Total Cool Cap.	Comp. Motor Input	Sensible To Total Ratio (S/T)			Total Cool Cap.	Comp. Motor Input	Sensible To Total Ratio (S/T)			Total Cool Cap.	Comp. Motor Input	Sensible To Total Ratio (S/T)		
				Dry Bulb					Dry Bulb					Dry Bulb					Dry Bulb		
cfm	kBtuh	kW	75°F	80°F	85°F	kBtuh	kW	75°F	80°F	85°F	kBtuh	kW	75°F	80°F	85°F	kBtuh	kW	75°F	80°F	85°F	
63°F	1200	36.0	3.38	0.32	0.50	0.67	29.3	3.61	0.21	0.42	0.63	22.5	3.93	0.02	0.30	0.58	15.6	4.35	-0.32	0.09	0.49
	1500	38.1	3.47	0.36	0.57	0.77	30.2	3.71	0.24	0.50	0.76	22.1	4.03	0.03	0.39	0.74	14.1	4.44	-0.42	0.15	0.70
	1800	39.5	3.54	0.41	0.64	0.88	30.4	3.78	0.28	0.59	0.89	21.2	4.10	0.05	0.50	0.92	12.0	4.51	-0.55	0.27	0.95
67°F	1200	42.1	3.47	0.18	0.33	0.48	35.2	3.71	0.06	0.24	0.42	28.2	4.04	-0.12	0.10	0.33	21.4	4.45	-0.41	-0.11	0.18
	1500	44.8	3.56	0.19	0.37	0.55	36.7	3.81	0.06	0.28	0.49	28.4	4.13	-0.15	0.13	0.40	20.2	4.54	-0.53	-0.13	0.26
	1800	46.4	3.63	0.21	0.42	0.62	37.1	3.87	0.07	0.32	0.57	27.8	4.20	-0.18	0.16	0.50	18.4	4.61	-0.67	-0.15	0.37
71°F	1200	48.6	3.56	0.07	0.20	0.33	41.6	3.81	-0.04	0.11	0.26	34.5	4.14	-0.21	-0.03	0.15	27.4	4.55	-0.46	-0.23	0.00
	1500	51.7	3.66	0.07	0.22	0.37	43.5	3.90	-0.07	0.11	0.30	35.1	4.24	-0.27	-0.04	0.18	26.7	4.65	-0.58	-0.29	0.01
	1800	53.6	3.73	0.06	0.24	0.42	44.3	3.98	-0.09	0.13	0.34	34.7	4.31	-0.32	-0.05	0.23	25.2	4.72	-0.72	-0.35	0.03

NOTE - Total Cooling Capacity is calculated at 80°F Dry Bulb.

**BLOWER DATA**

**BLOWER TABLE INCLUDES RESISTANCE FOR BASE UNIT ONLY WITH DRY INDOOR COIL AND AIR FILTERS IN PLACE.**

FOR ALL UNITS ADD:

1 - Any factory installed options air resistance (heat section, economizer, etc.).

2 - Any field installed accessories air resistance (duct resistance, diffuser, etc.).

**Minimum Air Volume Required For Different Gas Heat Sizes:**

Standard Heat - 960 cfm; Medium Heat - 1150 cfm; High Heat - 1500 cfm

See page 29 for wet coil and options/accessory air resistance data.

**DOWNFLOW**

External Static Press. in. w.g.	Percentage of Total Motor Torque																											
	20%			30%			40%			50%			60%			70%			80%			90%			100%			
	Cfm	Watts	RPM	Cfm	Watts	RPM	Cfm	Watts	RPM	Cfm	Watts	RPM	Cfm	Watts	RPM	Cfm	Watts	RPM	Cfm	Watts	RPM	Cfm	Watts	RPM	Cfm	Watts	RPM	
0	811	50	415	994	82	473	1177	114	531	1319	154	579	1461	194	626	1564	236	663	1667	278	700	1804	349	753	1878	396	783	
0.1	716	47	494	906	81	547	1095	115	599	1243	158	642	1391	200	685	1500	243	718	1608	286	751	1753	361	798	1833	409	824	
0.2	631	49	570	827	85	618	1023	121	665	1176	165	704	1329	209	742	1442	254	772	1555	299	802	1708	375	843	1794	425	865	
0.3	556	54	644	758	92	687	960	130	729	1118	176	764	1275	222	799	1392	268	825	1509	314	851	1668	392	888	1759	443	907	
0.4	489	62	715	696	102	753	903	142	791	1065	189	822	1227	236	853	1347	284	877	1467	331	900	1632	410	932	1726	462	949	
0.5	---	---	---	---	---	---	---	851	155	851	204	879	1183	253	906	1306	301	927	1429	349	948	1597	430	976	1693	481	991	
0.6	---	---	---	---	---	---	---	804	170	909	973	220	933	1141	269	957	1267	318	976	1392	367	994	1562	449	1019	1660	501	1032
0.7	---	---	---	---	---	---	---	759	184	964	930	235	985	1101	286	1006	1228	336	1023	1355	385	1039	1527	467	1062	1624	519	1074
0.8	---	---	---	---	---	---	---	716	199	1017	889	251	1036	1061	302	1054	1189	352	1069	1317	402	1083	1489	484	1103	1585	535	1115
0.9	---	---	---	---	---	---	---	671	211	1067	845	264	1083	1019	316	1099	1148	366	1112	1276	416	1125	1447	499	1144	1540	549	1156
1.0	---	---	---	---	---	---	---	625	222	1114	800	275	1128	974	327	1142	1102	378	1154	1230	428	1165	1400	510	1183	1489	559	1196
1.1	---	---	---	---	---	---	---	576	230	1158	751	283	1170	925	336	1182	1052	387	1193	1179	437	1203	1345	518	1221	1430	566	1235
1.2	---	---	---	---	---	---	---	521	234	1199	695	288	1210	869	341	1220	995	391	1230	1121	441	1240	1283	521	1258	1361	567	1273
1.3	---	---	---	---	---	---	---	---	---	---	---	---	---	806	340	1255	930	390	1265	1054	440	1274	1210	519	1293	1281	562	1311
1.4	---	---	---	---	---	---	---	---	---	---	---	---	---	734	335	1288	856	384	1297	977	433	1306	1126	510	1326	1188	552	1347

**HORIZONTAL**

External Static Press. in. w.g.	Percentage of Total Motor Torque																											
	20%			30%			40%			50%			60%			70%			80%			90%			100%			
	Cfm	Watts	RPM	Cfm	Watts	RPM	Cfm	Watts	RPM	Cfm	Watts	RPM	Cfm	Watts	RPM	Cfm	Watts	RPM	Cfm	Watts	RPM	Cfm	Watts	RPM	Cfm	Watts	RPM	
0	794	45	388	970	76	454	1146	107	519	1281	149	575	1416	191	630	1522	110	678	1627	293	726	1715	351	768	1802	408	810	
0.1	709	44	460	895	78	519	1080	111	577	1223	155	627	1366	199	677	1477	251	721	1588	303	764	1681	362	804	1773	420	843	
0.2	630	46	531	855	82	583	1019	117	634	1169	163	679	1318	208	723	1435	262	763	1552	315	803	1648	375	841	1743	434	878	
0.3	556	51	602	759	88	646	961	125	690	1117	172	730	1273	219	769	1395	274	805	1516	328	841	1615	388	877	1714	448	912	
0.4	486	58	671	696	97	709	906	135	746	1068	184	781	1230	232	815	1356	288	848	1481	343	880	1582	403	914	1683	463	948	
0.5	420	66	740	637	107	771	854	147	802	1021	196	831	1188	245	860	1317	301	890	1446	357	919	1549	418	951	1652	478	983	
0.6	---	---	---	---	---	---	---	804	159	856	946	209	881	1147	259	905	1279	316	932	1410	372	958	1514	432	989	1618	492	1019
0.7	---	---	---	---	---	---	---	756	172	910	932	223	930	1107	273	949	1241	330	973	1374	386	996	1478	446	1026	1582	506	1055
0.8	---	---	---	---	---	---	---	709	185	962	888	236	978	1066	287	993	1201	344	1014	1336	400	1034	1440	460	1063	1544	519	1091
0.9	---	---	---	---	---	---	---	663	197	1013	844	249	1025	1025	300	1036	1161	357	1054	1296	413	1072	1399	472	1100	1502	530	1127
1.0	---	---	---	---	---	---	---	---	---	---	---	---	982	313	1078	1118	369	1094	1254	424	1109	1355	482	1136	1456	540	1163	
1.1	---	---	---	---	---	---	---	---	---	---	---	---	938	323	1119	1073	379	1133	1208	434	1146	1307	491	1172	1406	548	1198	
1.2	---	---	---	---	---	---	---	---	---	---	---	---	892	332	1158	1026	387	1170	1159	441	1182	1255	497	1208	1351	553	1233	
1.3	---	---	---	---	---	---	---	---	---	---	---	---	843	340	1197	975	393	1207	1106	446	1216	1198	501	1242	1290	555	1268	
1.4	---	---	---	---	---	---	---	---	---	---	---	---	790	344	1234	920	396	1242	1049	448	1250	1137	501	1276	1224	553	1302	

**BLOWER DATA**

**BLOWER TABLE INCLUDES RESISTANCE FOR BASE UNIT ONLY WITH DRY INDOOR COIL AND AIR FILTERS IN PLACE.**

FOR ALL UNITS ADD:

- 1 - Any factory installed options air resistance (heat section, economizer, etc.).
- 2 - Any field installed accessories air resistance (duct resistance, diffuser, etc.).

**Minimum Air Volume Required For Different Gas Heat Sizes:**

Standard Heat - 960 cfm; Medium Heat - 1150 cfm; High Heat - 1500 cfm

See page 29 for wet coil and options/accessory air resistance data.

**DOWNFLOW**

External Static Press. in. w.g.	Percentage of Total Motor Torque																										
	20%			30%			40%			50%			60%			70%			80%			90%			100%		
	Cfm	RPM	Watts	Cfm	RPM	Watts	Cfm	RPM	Watts	Cfm	RPM	Watts	Cfm	RPM	Watts	Cfm	RPM	Watts	Cfm	RPM	Watts	Cfm	RPM	Watts	Cfm	RPM	
0	1067	112	488	1325	196	573	1583	279	657	1759	381	726	1934	482	794	2046	579	845	2157	676	896	2285	816	956	2358	925	989
0.1	984	97	537	1249	184	616	1513	270	695	1697	376	760	1881	481	825	2002	584	873	2123	686	921	2273	838	978	2352	947	1008
0.2	912	91	587	1183	180	661	1453	268	735	1644	377	796	1835	486	856	1964	593	902	2093	700	947	2264	863	1001	2349	973	1030
0.3	851	92	636	1126	183	706	1400	273	775	1597	385	832	1794	497	889	1931	607	932	2067	717	974	2256	891	1026	2348	1001	1053
0.4	797	100	687	1075	192	751	1353	283	815	1555	397	869	1757	511	922	1901	625	962	2044	738	1002	2248	919	1051	2347	1031	1077
0.5	752	114	737	1032	206	796	1312	298	855	1518	413	905	1724	528	955	1873	644	993	2021	760	1030	2239	948	1078	2345	1061	1102
0.6	712	132	787	994	224	842	1275	316	896	1484	432	942	1692	548	988	1845	666	1024	1998	783	1059	2228	977	1104	---	---	---
0.7	678	155	836	960	246	886	1242	336	936	1452	452	979	1662	568	1021	1818	687	1055	1974	806	1088	2214	1004	1131	---	---	---
0.8	648	180	885	929	269	931	1210	358	976	1421	474	1016	1632	589	1055	1790	709	1086	1948	828	1117	2195	1028	1158	---	---	---
0.9	621	207	933	900	294	974	1179	381	1015	1390	495	1051	1600	609	1087	1760	728	1117	1919	847	1146	2170	1049	1185	---	---	---
1.0	596	235	981	872	319	1017	1148	403	1053	1357	516	1086	1566	628	1119	1725	746	1147	1884	864	1174	2139	1066	1212	---	---	---
1.1	---	---	---	---	---	---	1115	424	1090	1322	534	1120	1528	643	1150	1686	760	1176	1844	876	1201	2100	1078	1238	---	---	---
1.2	---	---	---	---	---	---	1080	443	1126	1283	549	1153	1485	655	1180	1641	770	1204	1797	884	1228	2052	1083	1264	---	---	---
1.3	---	---	---	---	---	---	1040	458	1161	1238	561	1185	1436	663	1209	1589	775	1231	1742	886	1253	1993	1081	1288	---	---	---
1.4	---	---	---	---	---	---	996	469	1194	1189	567	1215	1381	665	1236	1530	773	1257	1678	881	1277	1923	1071	1311	---	---	---

**HORIZONTAL**

External Static Press. in. w.g.	Percentage of Total Motor Torque																										
	20%			30%			40%			50%			60%			70%			80%			90%			100%		
	Cfm	RPM	Watts	Cfm	RPM	Watts	Cfm	RPM	Watts	Cfm	RPM	Watts	Cfm	RPM	Watts	Cfm	RPM	Watts	Cfm	RPM	Watts	Cfm	RPM	Watts	Cfm	RPM	
0	1087	111	493	1304	184	579	1520	257	665	1689	368	738	1857	478	810	1972	588	864	2087	698	918	2196	844	975	2283	925	1000
0.1	1021	104	537	1246	180	618	1470	255	699	1646	368	768	1821	480	837	1941	592	888	2061	704	938	2179	852	992	2255	926	1017
0.2	961	102	582	1193	181	658	1425	259	734	1607	373	799	1789	487	864	1914	601	912	2039	714	960	2163	864	1012	2231	932	1034
0.3	906	106	628	1145	186	699	1384	266	769	1572	382	831	1759	498	892	1889	613	938	2018	728	984	2149	879	1033	2209	941	1053
0.4	855	113	674	1101	196	740	1347	278	806	1540	396	864	1732	513	921	1866	629	965	1999	744	1008	2134	896	1054	---	---	---
0.5	808	125	720	1060	209	781	1312	293	842	1509	412	896	1706	530	950	1843	646	992	1980	762	1033	2119	915	1077	---	---	---
0.6	764	139	766	1022	225	823	1279	310	879	1481	430	930	1682	549	980	1821	666	1019	1960	782	1058	2102	935	1101	---	---	---
0.7	722	155	812	985	242	864	1247	328	916	1452	449	964	1657	569	1011	1799	686	1048	1940	803	1084	2084	955	1125	---	---	---
0.8	682	172	858	949	260	906	1216	348	953	1424	469	997	1632	589	1041	1776	706	1076	1919	823	1111	2063	974	1150	---	---	---
0.9	643	191	903	914	279	946	1185	367	989	1396	489	1030	1606	610	1071	1751	727	1104	1895	843	1137	2039	992	1175	---	---	---
1.0	---	---	---	---	---	---	1153	386	1024	1366	508	1062	1579	629	1100	1724	745	1132	1869	861	1163	2011	1008	1201	---	---	---
1.1	---	---	---	---	---	---	1120	404	1059	1334	525	1095	1548	646	1130	1694	761	1160	1839	876	1189	1979	1021	1226	---	---	---
1.2	---	---	---	---	---	---	1085	420	1093	1300	541	1126	1515	661	1158	1660	775	1186	1805	889	1214	1941	1031	1250	---	---	---
1.3	---	---	---	---	---	---	1047	433	1126	1263	553	1156	1478	672	1186	1622	785	1213	1766	898	1239	1897	1037	1275	---	---	---
1.4	---	---	---	---	---	---	1005	442	1158	1221	561	1185	1436	680	1212	1579	792	1238	1721	903	1263	1847	1037	1298	---	---	---

**BLOWER DATA** **1.5 HP**

**BLOWER TABLE INCLUDES RESISTANCE FOR BASE UNIT ONLY WITH DRY INDOOR COIL AND AIR FILTERS IN PLACE.**

FOR ALL UNITS ADD:

1 - Any factory installed options air resistance (heat section, economizer, etc.).

2 - Any field installed accessories air resistance (duct resistance, diffuser, etc.).

**Minimum Air Volume Required For Different Gas Heat Sizes:**

Standard Heat - 1075 cfm; Medium Heat - 1150 cfm; High Heat - 1500 cfm

See page 29 for wet coil and options/accessory air resistance data.

**DOWNFLOW**

Total Air cfm	Total Static Pressure - in. w.g.																										
	0.1		0.2		0.3		0.4		0.5		0.6		0.7		0.8		0.9		1.0		1.1		1.2		1.3		
	RPM	Watts	RPM	Watts	RPM	Watts	RPM	Watts	RPM	Watts	RPM	Watts	RPM	Watts	RPM	Watts	RPM	Watts	RPM	Watts	RPM	Watts	RPM	Watts	RPM	Watts	RPM
400	---	734	19	823	40	944	73	1029	93	1108	111	1180	127	1248	139	1315	149	1383	158	1451	169	---	---	---	---	---	---
600	766	856	51	944	73	1029	93	1108	111	1180	127	1248	139	1315	149	1383	158	1451	169	---	---	---	---	---	---	---	---
800	899	989	81	1079	104	1163	125	1242	145	1317	161	1386	174	1454	185	1519	198	1582	214	1643	234	1701	255	1755	281	350	
1000	1084	1163	117	1244	139	1323	160	1398	180	1470	196	1538	211	1603	227	1663	245	1721	267	1776	292	1828	320	1876	350	427	
1200	1319	1385	138	1451	162	1517	186	1581	209	1644	231	1703	254	1759	278	1812	306	1863	337	1912	367	1960	397	2003	427	508	
1400	1542	1596	177	1649	208	1703	239	1757	269	1809	300	1860	331	1909	362	1956	393	2003	425	2050	456	2095	483	2139	508	590	
1600	1721	1772	258	1823	291	1873	324	1923	356	1972	388	2019	419	2065	450	2110	480	2156	510	2200	539	2244	565	2287	590	685	
1800	1909	1957	341	2006	373	2054	404	2101	435	2146	465	2190	495	2234	526	2277	557	2320	588	2362	620	2404	651	2444	685	822	
2000	2103	2148	417	2193	450	2239	483	2283	516	2325	550	2367	584	2408	620	2449	658	2490	696	2529	735	2568	777	2605	822	982	
2200	2299	2342	514	2384	552	2426	590	2467	630	2507	671	2547	714	2586	757	2625	800	2663	844	2700	889	2735	935	2770	982	1141	
2400	2500	2540	647	2580	690	2618	734	2656	779	2694	824	2731	870	2768	915	2804	961	2839	1006	2874	1051	2907	1096	2941	1141	1300	
2600	2704	2741	810	2778	855	2813	901	2849	947	2884	993	2918	1039	2952	1085	2986	1129	3019	1173	3051	1217	3083	1259	3115	1300	1456	
2800	2908	2943	985	2976	1030	3010	1076	3042	1121	3075	1166	3107	1210	3139	1253	3170	1296	3200	1338	3231	1379	3261	1419	3290	1456	1609	
3000	3110	3142	1156	3173	1201	3205	1245	3236	1289	3267	1332	3296	1373	3325	1414	3354	1455	3382	1496	3412	1536	3439	1573	3465	1609	1867	

**Total Static Pressure - in. w.g.**

Total Air cfm	1.4								1.5								1.6								1.7								1.8								1.9								2.0																																																																																																																																																																																																																																																																																																																																																																																																																																																																																																																																																																																																																																																																																																																																																																																																										
	RPM		Watts		RPM		Watts		RPM		Watts		RPM		Watts		RPM		Watts		RPM		Watts		RPM		Watts		RPM		Watts		RPM		Watts		RPM		Watts																																																																																																																																																																																																																																																																																																																																																																																																																																																																																																																																																																																																																																																																																																																																																																																																																				
	800	1805	309	1850	337	1895	366	1940	392	1985	421	2005	439	2050	466	2094	492	2138	517	2181	541	2225	565	2268	591	2310	610	2352	640	2393	671	2433	703	2474	735	2514	767	2554	799	2594	831	2634	863	2674	895	2714	927	2754	959	2794	991	2834	1023	2874	1055	2914	1087	2954	1119	2994	1151	3034	1183	3074	1215	3114	1247	3154	1279	3194	1311	3234	1343	3274	1375	3314	1407	3354	1439	3394	1471	3434	1503	3474	1535	3514	1567	3554	1599	3594	1631	3634	1663	3674	1695	3714	1727	3754	1759	3794	1791	3834	1823	3874	1855	3914	1887	3954	1919	3994	1951	4034	1983	4074	2015	4114	2047	4154	2079	4194	2111	4234	2143	4274	2175	4314	2207	4354	2239	4394	2271	4434	2303	4474	2335	4514	2367	4554	2399	4594	2431	4634	2463	4674	2495	4714	2527	4754	2559	4794	2591	4834	2623	4874	2655	4914	2687	4954	2719	4994	2751	5034	2783	5074	2815	5114	2847	5154	2879	5194	2911	5234	2943	5274	2975	5314	3007	5354	3039	5394	3071	5434	3103	5474	3135	5514	3167	5554	3199	5594	3231	5634	3263	5674	3295	5714	3327	5754	3359	5794	3391	5834	3423	5874	3455	5914	3487	5954	3519	5994	3551	6034	3583	6074	3615	6114	3647	6154	3679	6194	3711	6234	3743	6274	3775	6314	3807	6354	3839	6394	3871	6434	3903	6474	3935	6514	3967	6554	3999	6594	4031	6634	4063	6674	4095	6714	4127	6754	4159	6794	4191	6834	4223	6874	4255	6914	4287	6954	4319	6994	4351	7034	4383	7074	4415	7114	4447	7154	4479	7194	4511	7234	4543	7274	4575	7314	4607	7354	4639	7394	4671	7434	4703	7474	4735	7514	4767	7554	4799	7594	4831	7634	4863	7674	4895	7714	4927	7754	4959	7794	4991	7834	5023	7874	5055	7914	5087	7954	5119	7994	5151	8034	5183	8074	5215	8114	5247	8154	5279	8194	5311	8234	5343	8274	5375	8314	5407	8354	5439	8394	5471	8434	5503	8474	5535	8514	5567	8554	5599	8594	5631	8634	5663	8674	5695	8714	5727	8754	5759	8794	5791	8834	5823	8874	5855	8914	5887	8954	5919	8994	5951	9034	5983	9074	6015	9114	6047	9154	6079	9194	6111	9234	6143	9274	6175	9314	6207	9354	6239	9394	6271	9434	6303	9474	6335	9514	6367	9554	6399	9594	6431	9634	6463	9674	6495	9714	6527	9754	6559	9794	6591	9834	6623	9874	6655	9914	6687	9954	6719	9994	6751	10034	6783	10074	6815	10114	6847	10154	6879	10194	6911	10234	6943	10274	6975	10314	7007	10354	7039	10394	7071	10434	7103	10474	7135	10514	7167	10554	7199	10594	7231	10634	7263	10674	7295	10714	7327	10754	7359	10794	7391	10834	7423	10874	7455	10914	7487	10954	7519	10994	7551	11034	7583	11074	7615	11114	7647	11154	7679	11194	7711	11234	7743	11274	7775	11314	7807	11354	7839	11394	7871	11434	7903	11474	7935	11514	7967	11554	7999	11594	8031	11634	8063	11674	8095	11714	8127	11754	8159	11794	8191	11834	8223	11874	8255	11914	8287	11954	8319	11994	8351	12034	8383	12074	8415	12114	8447	12154	8479	12194	8511	12234	8543	12274	8575	12314	8607	12354	8639	12394	8671	12434	8703	12474	8735	12514	8767	12554	8799	12594	8831	12634	8863	12674	8895	12714	8927	12754	8959	12794	8991	12834	9023	12874	9055	12914	9087	12954	9119	12994	9151	13034	9183	13074	9215	13114	9247	13154	9279	13194	9311	13234	9343	13274	9375	13314	9407	13354	9439	13394	9471	13434	9503	13474	9535	13514	9567	13554	9599	13594	9631	13634	9663	13674	9695	13714	9727	13754	9759	13794	9791	13834	9823	13874	9855	13914	9887	13954	9919	13994	9951	14034	9983	14074	10015	14114	10047	14154	10079	14194	10111	14234	10143	14274	10175	14314	10207	14354	10239	14394	10271	14434	10303	14474	10335	14514	10367	14554	10399	14594	10431	14634	10463	14674	10495	14714	10527	14754	10559	14794	10591	14834	10623	14874	10655	14914	10687	14954	10719	14994	10751	15034	10783	15074	10815	15114	10847	15154	10879	15194	10911	15234	10943	15274	10975	15314	11007	15354	11039	15394	11071	15434	11103	15474	11135	15514	11167	15554	11199	15594	11231	15634	11263	15674	11295	15714	11327	15754	11359	15794	11391	15834	11423	15874	11455	15914	11487	15954	11519	15994	11551	16034	11583	16074	11615	16114	11647	16154	11679	16194	11711	16234	11743	16274	11775	16314	11807	16354	11839	16394	11871	16434	11903	16474	11935	16514	11967	16554	11999	16594	12031	16634	12063	16674	12095	16714	12127	16754	12159	16794	12191	16834	12223	16874	12255	16914	12287	16954	12319	16994	12351	17034	12383	17074	12415	17114	12447	17154	12479	17194	12511	17234	12543	17274	12575	17314	12607	17354	12639	17394	12671	17434	12703	17474	12735	17514	12767	17554	12799	17594	12831	17634	12863	17674	12895	17714	12927	17754	12959	17794	12991	17834	13023	17874	13055	17914	13087	17954	13119	17994	13151	18034	13183	18074	13215	18114	13247	18154	13279	18194	13311	18234	13343	18274	13375	18314	13407

**BLOWER DATA**  
**BLOWER TABLE INCLUDES RESISTANCE FOR BASE UNIT ONLY WITH DRY INDOOR COIL AND AIR FILTERS IN PLACE.**

FOR ALL UNITS ADD:  
 1 - Any factory installed options air resistance (heat section, economizer, etc.).  
 2 - Any field installed accessories air resistance (duct resistance, diffuser, etc.).

**Minimum Air Volume Required For Different Gas Heat Sizes:**  
 Standard Heat - 1075 cfm; Medium Heat - 1150 cfm; High Heat - 1500 cfm

See page 29 for wet coil and options/accessory air resistance data.

**HORIZONTAL**

Total Air cfm	Total Static Pressure - in. w.g.																									
	0.1		0.2		0.3		0.4		0.5		0.6		0.7		0.8		0.9		1.0		1.1		1.2		1.3	
	RPM	Watts	RPM	Watts	RPM	Watts	RPM	Watts	RPM	Watts	RPM	Watts	RPM	Watts	RPM	Watts	RPM	Watts	RPM	Watts	RPM	Watts	RPM	Watts	RPM	Watts
400	708	16	793	37	872	53	---	---	---	---	---	---	---	---	---	---	---	---	---	---	---	---	---	---	---	---
600	835	46	918	65	1000	82	1077	95	1149	107	1221	109	---	---	---	---	---	---	---	---	---	---	---	---	---	---
800	981	75	1064	92	1144	109	1221	124	1294	139	1365	148	1434	154	1497	163	1555	179	1607	200	1656	226	1704	254	---	---
1000	1166	105	1241	124	1315	141	1387	159	1454	176	1520	191	1582	207	1638	227	1689	252	1737	279	1783	308	1829	335	1873	362
1200	1374	142	1440	162	1506	182	1569	203	1630	224	1687	246	1739	271	1787	299	1832	330	1876	361	1920	391	1964	419	2007	444
1400	1591	183	1647	209	1701	235	1755	263	1806	291	1854	320	1899	351	1942	382	1984	412	2026	442	2068	469	2110	496	2153	520
1600	1778	258	1827	290	1876	323	1923	355	1970	386	2015	416	2059	444	2102	470	2144	494	2185	519	2227	545	2268	572	2309	600
1800	1973	352	2018	383	2063	415	2107	445	2151	476	2194	504	2237	531	2279	557	2319	584	2359	613	2397	645	2435	679	2471	713
2000	2182	437	2224	468	2265	499	2306	531	2346	563	2385	596	2424	630	2461	666	2496	705	2530	745	2564	786	2598	826	2631	866
2200	2388	540	2426	576	2464	613	2500	651	2536	691	2571	731	2605	774	2637	819	2668	863	2700	907	2732	949	2764	990	2795	1029
2400	2589	679	2624	719	2658	761	2691	803	2724	846	2756	890	2786	935	2816	980	2846	1025	2876	1068	2907	1109	2937	1149	2967	1188
2600	2787	845	2819	887	2850	930	2881	973	2911	1017	2941	1060	2970	1104	2999	1147	3028	1189	3057	1230	3087	1270	---	---	---	---
2800	2983	1021	3013	1063	3042	1106	3070	1149	3099	1191	---	---	---	---	---	---	---	---	---	---	---	---	---	---	---	---

**Total Static Pressure - in. w.g.**

Total Air cfm	Total Static Pressure - in. w.g.													
	1.4		1.5		1.6		1.7		1.8		1.9		2.0	
	RPM	Watts	RPM	Watts	RPM	Watts	RPM	Watts	RPM	Watts	RPM	Watts	RPM	Watts
800	---	---	---	---	---	---	---	---	---	---	---	---	---	---
1000	1916	386	1957	408	1998	428	2037	447	2077	465	---	---	---	---
1200	2049	468	2089	490	2128	510	2168	529	2207	549	2246	569	2285	591
1400	2194	543	2235	565	2274	588	2313	611	2350	637	2387	664	2423	694
1600	2349	627	2387	657	2423	688	2457	722	2490	757	2522	793	2554	830
1800	2506	749	2539	787	2571	825	2602	864	2632	903	2662	942	2692	981
2000	2663	906	2694	945	2725	985	2755	1024	2785	1063	2815	1101	2845	1138
2200	2826	1068	2857	1107	2887	1146	2916	1184	2946	1221	2975	1259	3005	1296
2400	2997	1227	3027	1266	3056	1304	3085	1342	---	---	---	---	---	---
2600	---	---	---	---	---	---	---	---	---	---	---	---	---	---
2800	---	---	---	---	---	---	---	---	---	---	---	---	---	---

## BLOWER DATA

### FACTORY INSTALLED OPTIONS/FIELD INSTALLED ACCESSORY AIR RESISTANCE - in. w.g.

Air Volume cfm	Wet Indoor Coil	Humiditrol® Reheat Coil	Gas Heating			Economizer	Filters		
			Standard Heat	Medium Heat	High Heat		MERV 8	MERV 13	MERV 16
800	0.01	- - -	0.02	0.02	0.02	0.04	0.04	0.05	0.04
1000	0.02	0.00	0.02	0.02	0.02	0.04	0.04	0.07	0.05
1200	0.04	0.00	0.02	0.02	0.02	0.04	0.04	0.07	0.05
1400	0.05	0.01	0.02	0.02	0.03	0.04	0.04	0.07	0.06
1600	0.07	0.02	0.02	0.03	0.04	0.04	0.04	0.07	0.08
1800	0.08	0.02	0.03	0.04	0.05	0.05	0.04	0.07	0.09
2000	0.10	0.02	0.03	0.04	0.06	0.05	0.05	0.08	0.10
2200	0.11	0.04	0.04	0.04	0.07	0.05	0.05	0.08	0.11
2400	0.13	0.04	0.04	0.05	0.08	0.05	0.05	0.08	0.12

### POWER EXHAUST FAN PERFORMANCE

Return Air System Static Pressure in. w.g.	Air Volume Exhausted cfm
0.00	2000
0.05	1990
0.10	1924
0.15	1810
0.20	1664
0.25	1507
0.30	1350
0.35	1210

## BLOWER DATA

### CEILING DIFFUSERS AIR RESISTANCE (in. w.g.)

Air Volume cfm	RTD9-65S Step-Down Diffuser			FD9-65S Flush Diffuser	RTD11-95S Step-Down Diffuser			FD11-95S Flush Diffuser
	2 Ends Open	1 Side & 2 Ends Open	All Ends & Sides Open		2 Ends Open	1 Side & 2 Ends Open	All Ends & Sides Open	
800	0.15	0.13	0.11	0.11	---	---	---	---
1000	0.19	0.16	0.14	0.14	---	---	---	---
1200	0.25	0.20	0.17	0.17	---	---	---	---
1400	0.33	0.26	0.20	0.20	---	---	---	---
1600	0.43	0.32	0.20	0.24	---	---	---	---
1800	0.56	0.40	0.30	0.30	0.13	0.11	0.09	0.09
2000	0.73	0.50	0.36	0.36	0.15	0.13	0.11	0.10
2200	0.95	0.63	0.44	0.44	0.18	0.15	0.12	0.12
2400	---	----	---	---	0.21	0.18	0.15	0.14
2600	---	----	---	---	0.24	0.21	0.18	0.17
2800	---	----	---	---	0.27	0.24	0.21	0.20
3000	---	----	---	---	0.32	0.29	0.25	0.25

### CEILING DIFFUSER AIR THROW DATA

Air Volume - cfm	<sup>1</sup> Effective Throw - ft.	
	Model	Model
	<b>RTD9-65S</b>	<b>FD9-65S</b>
800	10 - 17	14 - 18
1000	10 - 17	15 - 20
1200	11 - 18	16 - 22
1400	12 - 19	17 - 24
1600	12 - 20	18 - 25
1800	13 - 21	20 - 28
2000	14 - 23	21 - 29
2200	16 - 25	22 - 30
	<b>RTD11-95S</b>	<b>FD11-95S</b>
2600	24 - 29	19 - 24
2800	25 - 30	20 - 28
3000	27 - 33	21 - 29

<sup>1</sup> Effective throw based on terminal velocities of 75 ft. per minute.

**ELECTRICAL DATA** **3 TON**

Model		LGT036H5E							
<sup>1</sup> Voltage - 60Hz		208/230V - 1 Ph		208/230V - 3 Ph		460V - 3 Ph		575V - 3 Ph	
Compressor	Rated Load Amps	14.3		9.1		4.6		3.5	
	Locked Rotor Amps	76		70		39		28.9	
Outdoor Fan Motor	Full Load Amps (1 ECM)	2.8		2.8		1.4		1.1	
Power Exhaust (1) 0.33 HP	Full Load Amps	2.4		2.4		1.3		1	
Service Outlet 115V GFI (amps)		15		15		15		20	
Indoor Blower Motor	HP	0.5	0.5	1.5	0.5	1.5	0.5	1.5	
	Full Load Amps	4.3	4.3	4.4	2.2	2.3	1.7	2.3	
<sup>2</sup> Maximum Overcurrent Protection (MOCP)	Unit Only	35	25	25	15	15	15	15	
	With (1) 0.33 HP Power Exhaust	40	25	30	15	15	15	15	
<sup>3</sup> Minimum Circuit Ampacity (MCA)	Unit Only	25	19	19	10	10	8	8	
	With (1) 0.33 HP Power Exhaust	28	21	21	11	11	9	9	

NOTE - All units have a minimum Short Circuit Current Rating (SCCR) of 5000 amps.

<sup>1</sup> Extremes of operating range are plus and minus 10% of line voltage.

<sup>2</sup> HACR type breaker or fuse.

<sup>3</sup> Refer to National or Canadian Electrical Code manual to determine wire, fuse and disconnect size requirements.

**ELECTRICAL DATA** **4 TON**

Model		LGT048H5E							
<sup>1</sup> Voltage - 60Hz		208/230V - 1 Ph		208/230V - 3 Ph		460V - 3 Ph		575V - 3 Ph	
Compressor	Rated Load Amps	17.2		10.2		6.1		3.7	
	Locked Rotor Amps	121		123		60		41	
Outdoor Fan Motor	Full Load Amps (1 ECM)	2.8		2.8		1.4		1.1	
Power Exhaust (1) 0.33 HP	Full Load Amps	2.4		2.4		1.3		1	
Service Outlet 115V GFI (amps)		15		15		15		20	
Indoor Blower Motor	HP	1	1	1.5	1	1.5	1	1.5	
	Full Load Amps	7.4	7.4	4.4	3.7	2.3	3	2.3	
<sup>2</sup> Maximum Overcurrent Protection (MOCP)	Unit Only	45	30	30	15	15	15	15	
	With (1) 0.33 HP Power Exhaust	50	35	30	20	15	15	15	
<sup>3</sup> Minimum Circuit Ampacity (MCA)	Unit Only	32	23	20	13	12	9	9	
	With (1) 0.33 HP Power Exhaust	35	26	23	15	13	10	10	

NOTE - All units have a minimum Short Circuit Current Rating (SCCR) of 5000 amps.

<sup>1</sup> Extremes of operating range are plus and minus 10% of line voltage.

<sup>2</sup> HACR type breaker or fuse.

<sup>3</sup> Refer to National or Canadian Electrical Code manual to determine wire, fuse and disconnect size requirements.

**ELECTRICAL DATA****5 TON**

Model		LGT060H5E						
<sup>1</sup> Voltage - 60Hz		208/230V - 1 Ph	208/230V - 3 Ph		460V - 3 Ph	575V - 3 Ph		
Compressor	Rated Load Amps	23.7	12.4		6.5	4.8		
	Locked Rotor Amps	123	93		60	41		
Outdoor Fan Motor	Full Load Amps (1 ECM)	2.8	2.8		1.4	1.1		
Power Exhaust (1) 0.33 HP	Full Load Amps	2.4	2.4		1.3	1		
Service Outlet 115V GFI (amps)		15	15		15	20		
Indoor Blower Motor	HP	1	1	1.5	1	1.5	1	1.5
	Full Load Amps	7.4	7.4	4.4	3.7	2.3	3	2.3
<sup>2</sup> Maximum Overcurrent Protection (MOCP)	Unit Only	60	35	35	15	15	15	15
	With (1) 0.33 HP Power Exhaust	60	40	35	20	15	15	15
<sup>3</sup> Minimum Circuit Ampacity (MCA)	Unit Only	40	26	23	14	12	11	10
	With (1) 0.33 HP Power Exhaust	43	29	26	15	14	12	11

NOTE - All units have a minimum Short Circuit Current Rating (SCCR) of 5000 amps.

<sup>1</sup> Extremes of operating range are plus and minus 10% of line voltage.<sup>2</sup> HACR type breaker or fuse.<sup>3</sup> Refer to National or Canadian Electrical Code manual to determine wire, fuse and disconnect size requirements.**ELECTRICAL DATA****6 TON**

Model		LGT072H5E		
<sup>1</sup> Voltage - 60Hz		208/230V - 3 Ph	460V - 3 Ph	575 - 3Ph
Compressor	Rated Load Amps	19.2	9.1	6.2
	Locked Rotor Amps	162.3	70.8	58.2
Outdoor Fan Motor	Full Load Amps (1 ECM)	2.8	1.4	1.1
Power Exhaust (1) 0.33 HP	Full Load Amps	2.4	1.3	1
Service Outlet 115V GFI (amps)		15	15	20
Indoor Blower Motor	HP	1.5	1.5	1.5
	Full Load Amps	4.4	2.3	2.3
<sup>2</sup> Maximum Overcurrent Protection (MOCP)	Unit Only	50	20	15
	With (1) 0.33 HP Power Exhaust	50	25	15
<sup>3</sup> Minimum Circuit Ampacity (MCA)	Unit Only	32	16	12
	With (1) 0.33 HP Power Exhaust	34	17	13

NOTE - All units have a minimum Short Circuit Current Rating (SCCR) of 5000 amps.

<sup>1</sup> Extremes of operating range are plus and minus 10% of line voltage.<sup>2</sup> HACR type breaker or fuse.<sup>3</sup> Refer to National or Canadian Electrical Code manual to determine wire, fuse and disconnect size requirements.**FIELD WIRING NOTES**

- For use with copper wiring only
- Field wiring not furnished
- All wiring must conform to NEC or CEC and local electrical codes
- For specific wiring information, please refer to the installation instructions

## OUTDOOR SOUND DATA

Size	Octave Band Sound Power Levels dBA, re 10 <sup>-12</sup> Watts Center Frequency - Hz							<sup>1</sup> Sound Rating Number dBA
	125	250	500	1000	2000	4000	8000	
036, 048	63	66	70	71	68	62	53	75
060, 072	67	72	77	76	73	68	61	82

NOTE - The octave sound power data does not include tonal corrections.

<sup>1</sup> 1 Sound Rating Number according to AHRI Standard 270-95 (includes pure tone penalty). Sound Rating Number is the overall A-Weighted Sound Power Level, (Lwa), dBA (100 Hz to 10,000 Hz).

## WEIGHT DATA

Size	Net		Shipping		UNIT
	lbs.	kg	lbs.	kg	
036 Base Unit	630	286	691	313	
036 Max. Unit	827	375	888	403	
048 Base Unit	629	285	690	313	
048 Max. Unit	826	375	890	404	
060 Base Unit	630	286	691	313	
060 Max. Unit	830	376	891	404	
072 Base Unit	630	286	691	313	
072 Max. Unit	830	376	891	404	

## FACTORY / FIELD INSTALLED OPTIONS AND ACCESSORIES - NET WEIGHTS

Description	lbs.	kg	
<b>ECONOMIZER / OUTDOOR AIR / EXHAUST</b>			
<b>Economizer</b>			
Economizer, Includes Combination Outdoor Air Hood and Barometric Relief Dampers	84	38	
<b>Outdoor Air Dampers</b>			
Motorized	40	18	
Manual	30	14	
<b>Power Exhaust</b>	35	17	
<b>GAS HEAT</b>			
Medium Heat (adder over low heat)	8	4	
High Heat (adder over standard heat)	19	9	
<b>COMBINATION COIL/HAIL GUARDS</b>			
All models	31	14	
<b>ROOF CURBS</b>			
<b>Hybrid Roof Curbs, Downflow</b>			
8 in. height	86	39	
14 in. height	108	49	
18 in. height	125	57	
24 in. height	147	67	
<b>Adjustable Pitch Curb, Downflow</b>			
14 in. height	147	67	
<b>CEILING DIFFUSERS</b>			
Step-Down	RTD9-65S	80	36
	RTD11-95S	118	54
Flush	FD9-65S	80	36
	FD11-95S	118	54
Transitions (Supply and Return)	T1TRAN10AN1	22	10
	T1TRAN20N-1	21	10
<b>HUMIDITROL® DEHUMIDIFICATION SYSTEM</b>			
Humiditrol Dehumidification Option (Net Weight)	27	12	

## UNIT CLEARANCES

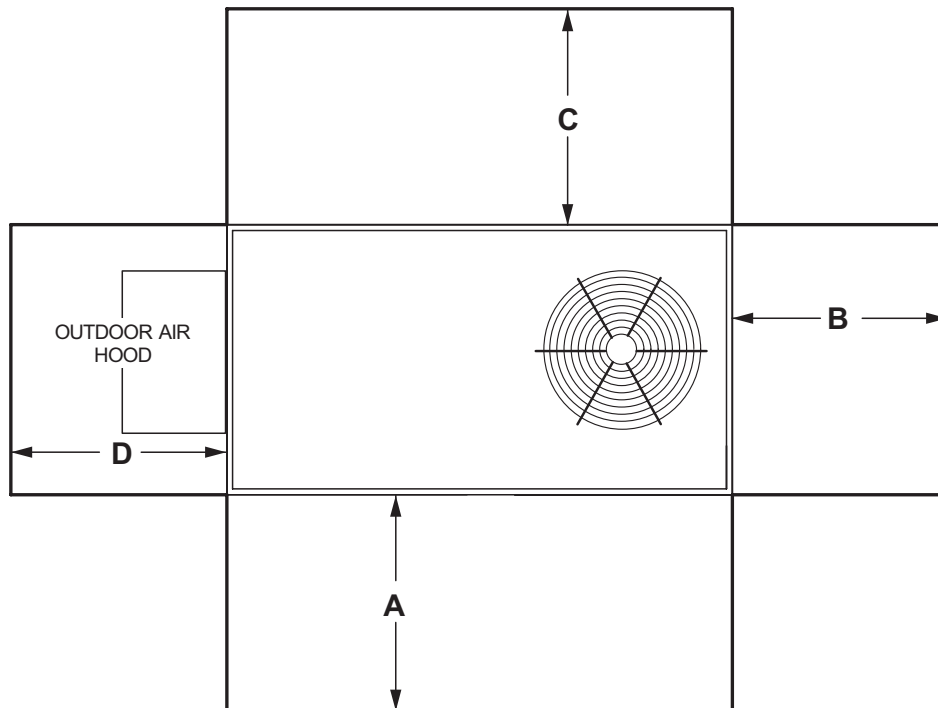

1 Unit Clearance	A		B		C		D		Top Clearance
	in.	mm	in.	mm	in.	mm	in.	mm	
Service Clearance	48	1219	36	914	36	934	36	914	Unobstructed
Clearance to Combustibles	36	914	1	25	1	25	1	25	
Minimum Operation Clearance	36	914	36	914	36	914	36	914	

NOTE - Entire perimeter of unit base requires support when elevated above the mounting surface.

<sup>1</sup> Service Clearance - Required for removal of serviceable parts.

Clearance to Combustibles - Required clearance to combustible material.

Minimum Operation Clearance - Required clearance for proper unit operation.

**DIMENSIONS**

**UNIT**

**CORNER WEIGHTS**

Model	AA		BB		CC		DD		EE		FF	
	lbs.	kg	lbs.	kg	lbs.	kg	lbs.	kg	in.	mm	in.	mm
	LGT036 Base Unit	131	59	161	73	220	100	179	81	38-1/4	972	19-7/8
LGT036 Max. Unit	168	76	207	94	283	128	230	104	39-3/4	1010	19-7/8	505
LGT048 Base Unit	131	59	161	73	220	100	179	81	38-1/4	972	19-7/8	505
LGT048 Max. Unit	169	77	207	94	283	128	230	104	39-3/4	1010	19-7/8	505
LGT060 Base Unit	131	59	161	73	220	100	179	81	38-1/4	972	19-7/8	505
LGT060 Max. Unit	169	77	208	94	284	129	231	105	39-3/4	1010	19-7/8	505
LGT072 Base Unit	131	59	161	73	220	100	179	81	38-1/4	972	19-7/8	505
LGT072 Max. Unit	169	77	208	94	284	129	231	105	39-3/4	1010	19-7/8	505

Base Unit - The unit with NO INTERNAL OPTIONS.

Max. Unit - The unit with ALL INTERNAL OPTIONS Installed. (Economizer, Standard Static Power Exhaust Fans, Controls, etc.). Does not include accessories external to unit or high static power exhaust.

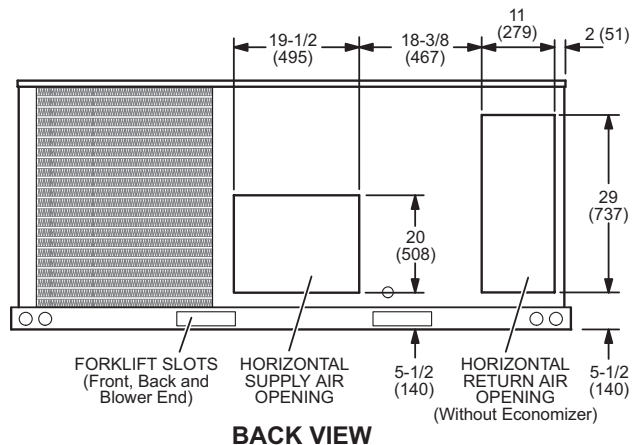
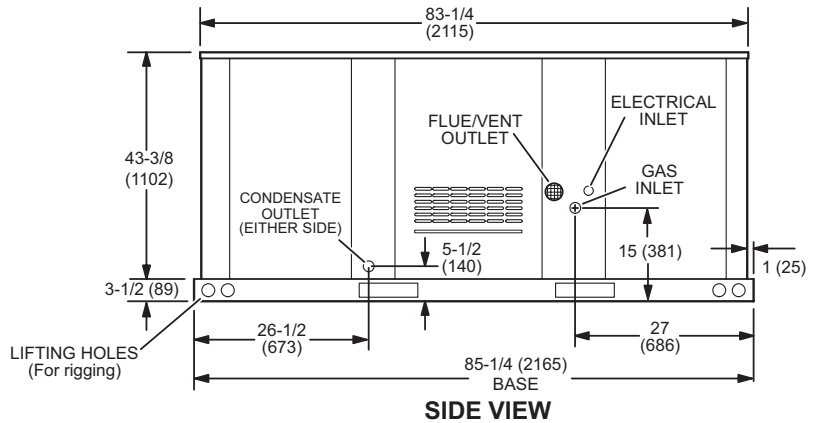
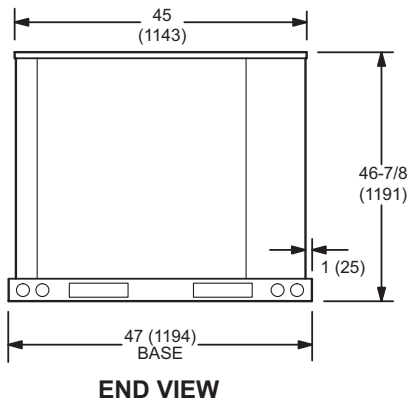
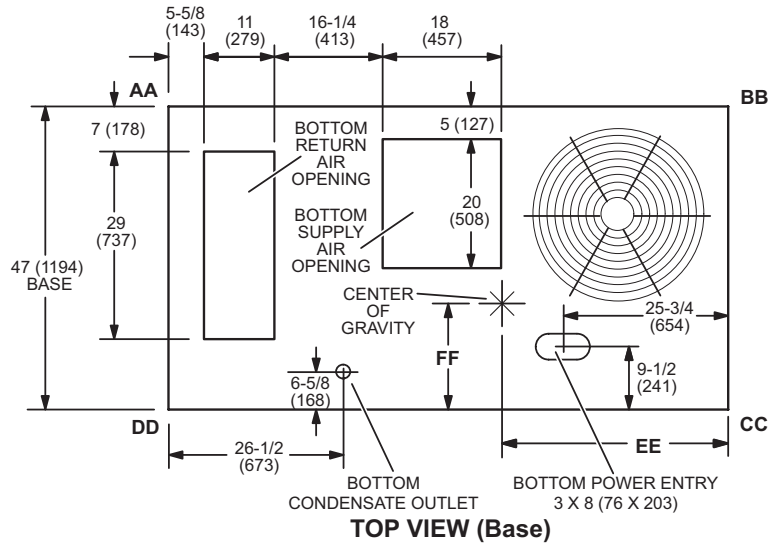

**COMBINATION OUTDOOR AIR HOOD DETAIL FOR OPTIONAL ECONOMIZER AND BAROMETRIC RELIEF DAMPERS  
(Furnished With Economizer for Downflow Applications)**

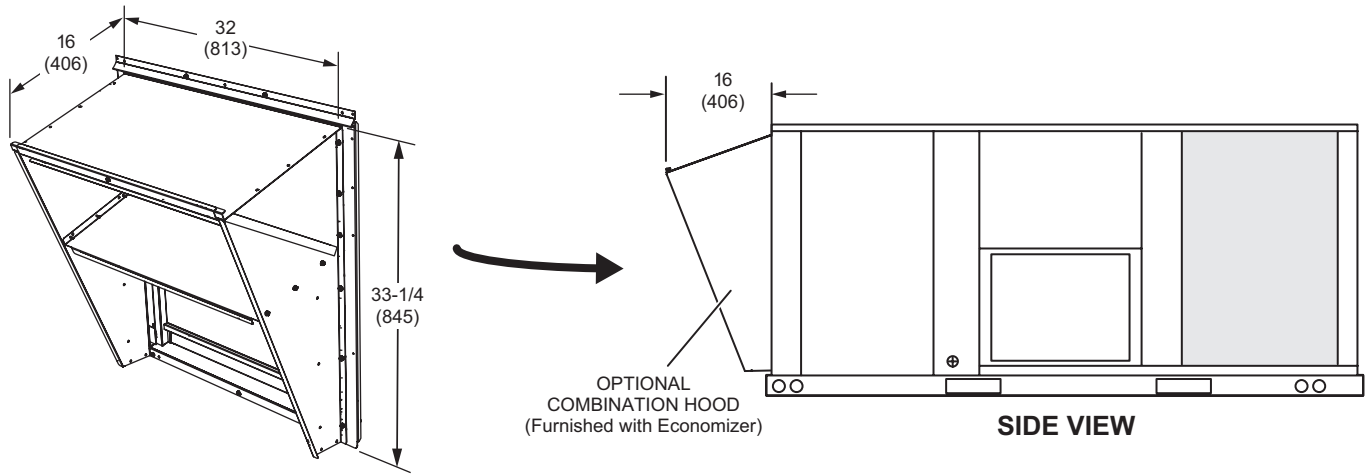

**OUTDOOR AIR DAMPER HOOD DETAIL (Downflow or Horizontal Applications)**

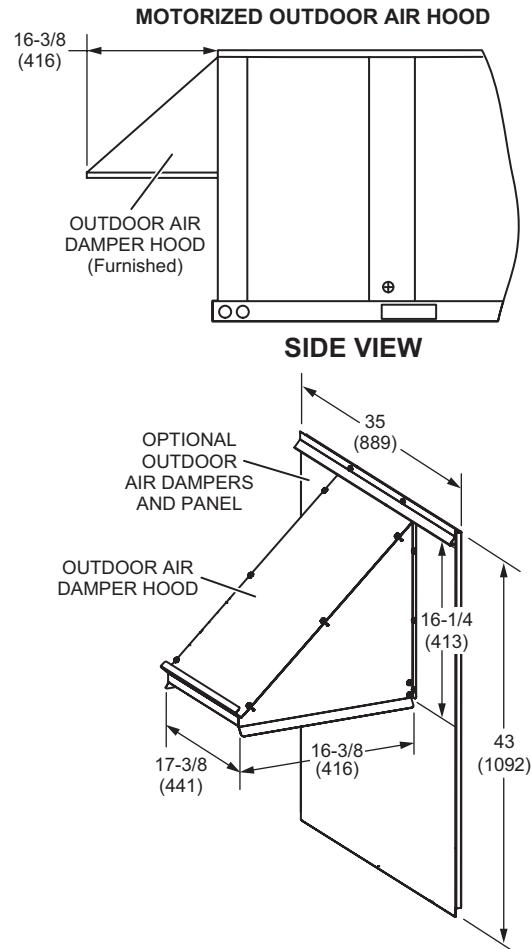
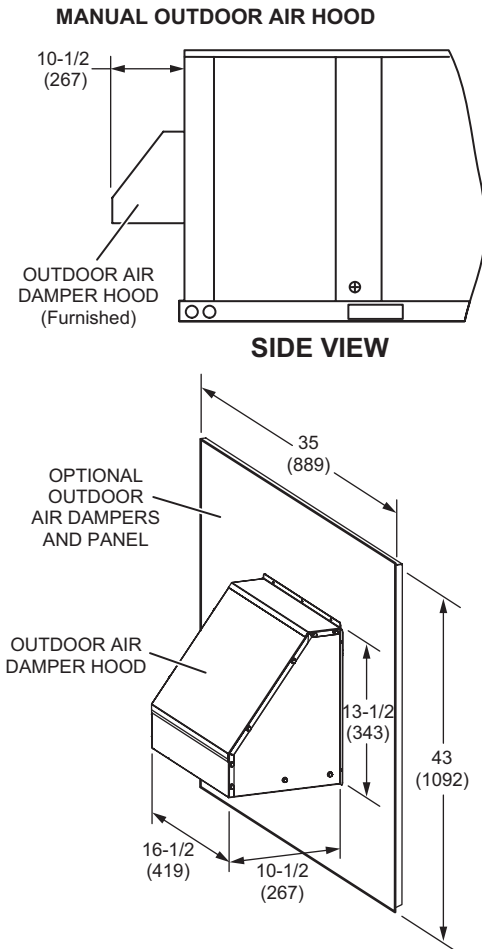

**HORIZONTAL ECONOMIZER APPLICATIONS - OUTDOOR AIR HOOD DETAIL WITH OPTIONAL ECONOMIZER DAMPERS AND OPTIONAL HORIZONTAL BAROMETRIC RELIEF DAMPERS AND HOOD**

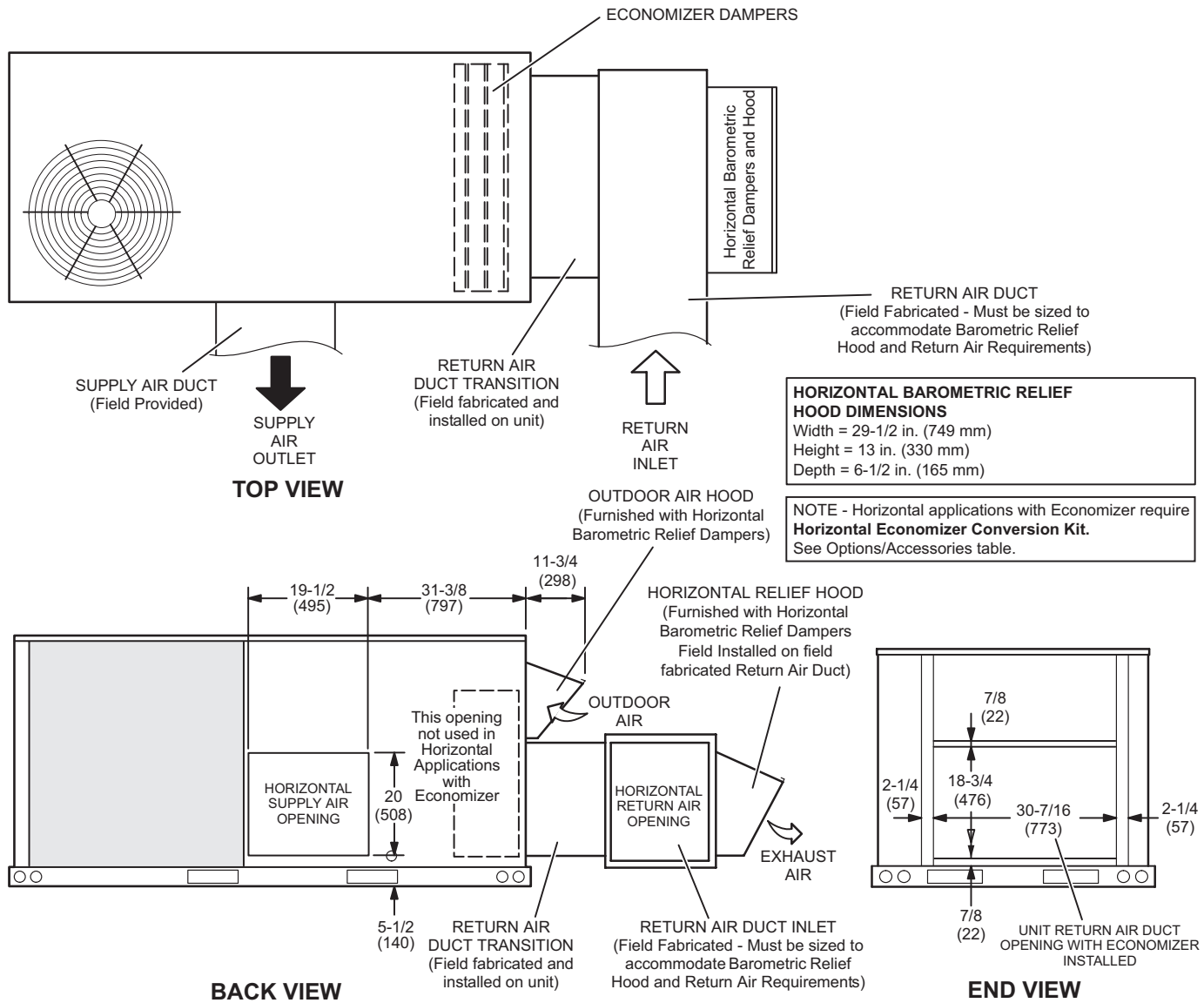

**NOTE - Return Air Duct and Transition must be supported.**



**ADJUSTABLE PITCH CURBS - DOUBLE DUCT OPENING**

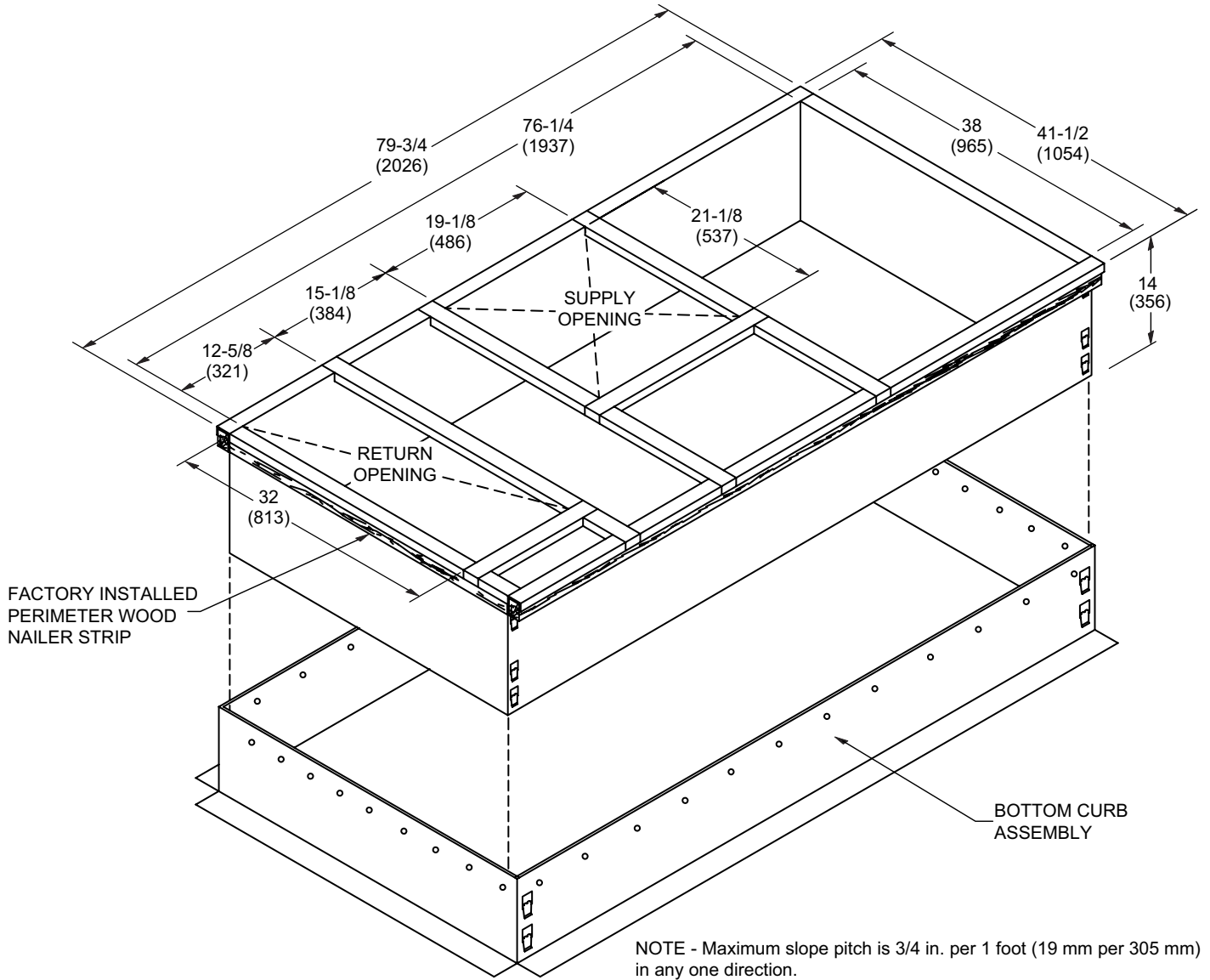

**TYPICAL FLASHING DETAIL FOR ROOF CURB**

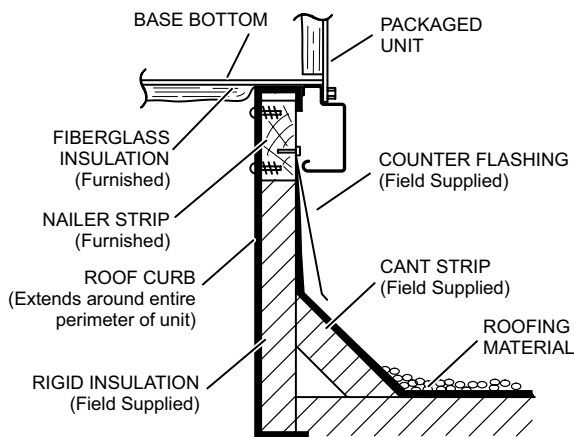

**DETAIL ROOF CURB**

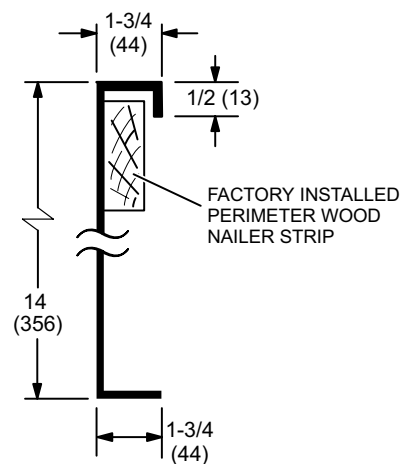

**TRANSITIONS**

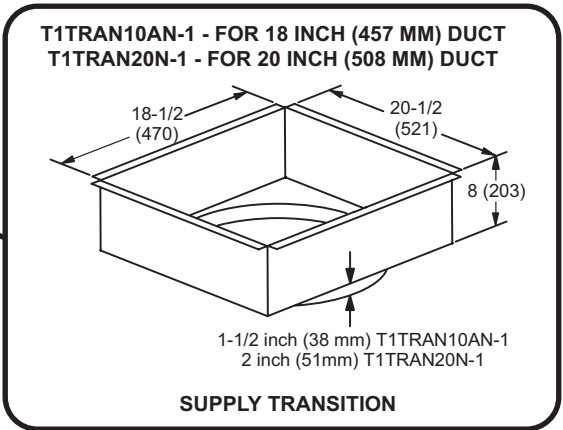
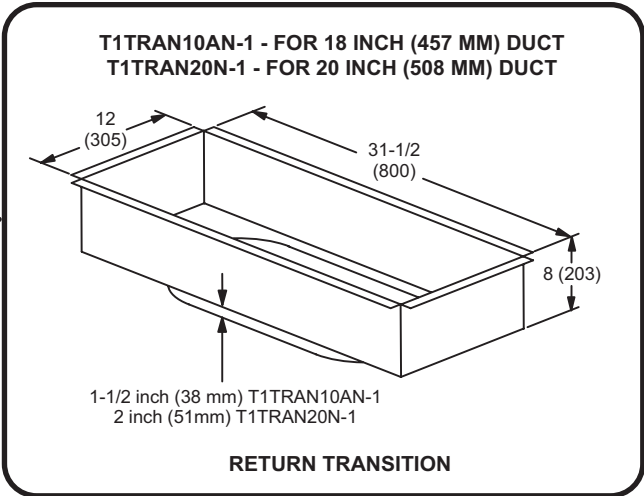
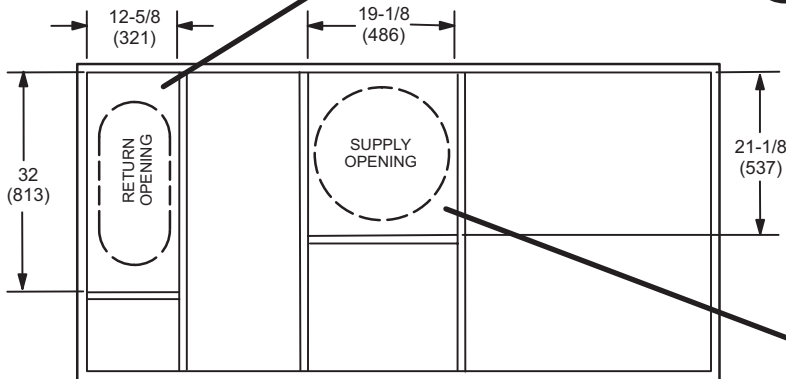

**COMBINATION CEILING SUPPLY AND RETURN DIFFUSERS**

**STEP-DOWN CEILING DIFFUSER**

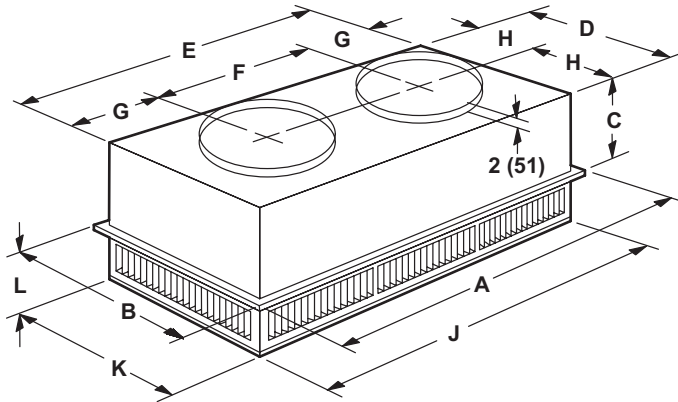

**FLUSH CEILING DIFFUSER**

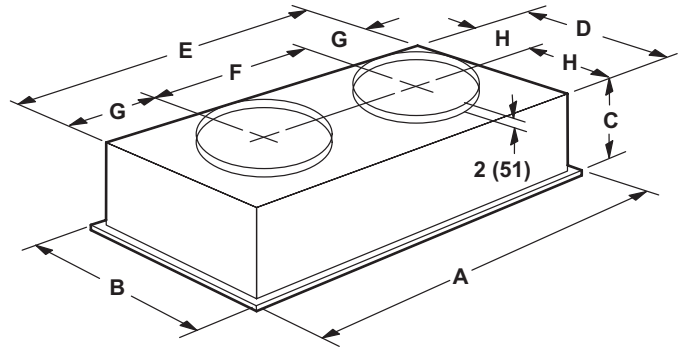

Model		RTD9-65S	RTD11-95S
A	in.	47-5/8	47-5/8
	mm	1159	1159
B	in.	23-5/8	29-5/8
	mm	600	752
C	in.	11-3/8	14-3/8
	mm	289	365
D	in.	21-1/2	27-1/2
	mm	546	699
E	in.	45-1/2	45-1/2
	mm	1156	1158
F	in.	22-1/2	22-1/2
	mm	572	572
G	in.	11-1/2	11-1/2
	mm	292	292
H	in.	10-3/4	13-3/4
	mm	273	349
J	in.	45-1/2	45-1/2
	mm	1156	1156
K	in.	21-1/2	27-1/2
	mm	546	699
L	in.	7-1/8	8-1/8
	mm	181	206
Duct Size	in.	18 round	20 round
	mm	457 round	508 round

Model		FD9-65S	FD11-95S
A	in.	47-5/8	47-5/8
	mm	1159	1159
B	in.	23-5/8	29-5/8
	mm	600	752
C	in.	13-1/2	16-5/8
	mm	343	422
D	in.	21	27
	mm	533	686
E	in.	45	45
	mm	1143	1143
F	in.	22-1/2	22-1/2
	mm	572	572
G	in.	11-1/4	11-1/4
	mm	286	286
H	in.	10-1/2	13-1/2
	mm	267	343
Duct Size	in.	18 round	20 round
	mm	457 round	508 round

## REVISIONS

Sections	Description of Change
Options / Accessories	Added modulating gas option.



**HRAI**  
✓ MEMBER COMPANY



**Intertek**



Visit us at [www.Lennox.com](http://www.Lennox.com)

For the latest technical information, [www.LennoxCommercial.com](http://www.LennoxCommercial.com)

Contact us at 1-800-4-LENNOX

NOTE - Due to Lennox' ongoing commitment to quality, Specifications, Ratings and Dimensions subject to change without notice and without incurring liability. Improper installation, adjustment, alteration, service or maintenance can cause property damage or personal injury. Installation and service must be performed by a qualified installer and servicing agency.