

DOAS Interface Module Installation manual

V2UCK01

- Thank you for purchasing this Lennox Product.
- Before operating this unit, please read this manual carefully and retain it for future reference.

Contents

| | |
|--|----|
| Safety Information | 3 |
| R-32 General Guidelines for Compliance | 5 |
| Name of each part and product dimension | 9 |
| Parts | 10 |
| Checking before using a DOAS Interface Module | 11 |
| Installing a DOAS Interface Module | 12 |
| Setting the address and installation option of DOAS Interface Module | 35 |
| Trouble shooting | 52 |
| Installation check and test operation | 62 |

Safety Information

California Proposition 65 Warning (US)

 **WARNING:** Cancer and Reproductive Harm - www.P65Warnings.ca.gov.

When installing the product, the following safety precautions must be taken for the safety of an installer and user.

Use R-410A/R-32 refrigerant.

- ▶ When using R-410A/R-32, the inflow of moisture or foreign substances may greatly affect the capacity and reliability of the product. Safety precautions must be taken when installing the refrigerant pipe.
 - ▶ When charging mixed refrigerant, you should use liquid refrigerant (If you charge gaseous refrigerant, it may affect the capacity and reliability of the product as a result of change in formation of the refrigerant.)
- ※ The manufacturer is not responsible for accidents due to incorrect installation. Any claims caused by failing to keep the safety precautions are installer's responsibility. (The installer is responsible for the service cost.)
- ※ This appliance is not intended for use by persons (including children) with reduced physical, sensory or mental capabilities, or lack of experience and knowledge, unless they have been given supervision or instruction concerning use of the appliance by a person responsible for their safety. Children should be supervised to ensure that they do not play with the appliance.
- ※ If the supply cord is damaged, it must be replaced by the manufacturer, its service agent or similarly qualified persons in order to avoid a hazard.

FOR INSTALLATION

 **WARNING**

Disconnect all the power supplies before installation, service, and cleaning.

The installation must be done by the manufacturer or a qualified person.

- ▶ Installation by an unqualified person may result in a water leakage, electric shock or fire.

Install the unit correctly according to the installation manual.

- ▶ An incorrect installation may result in a water leakage, electric shock or fire.

Manufacturer of DOAS Interface Module is not responsible for accidents due to incorrect installation by an unqualified person. Also, you should use only supplied or designated parts and tools for installation.

- ▶ If you don't use the designated parts and tools, product fall, water leakage, electric shock, or fire may occur.

When adding refrigerant, use the R-410A/R-32 refrigerant.

- ▶ Using other types of refrigerant may result in product malfunction, explosion etc.

Do not use the pipe for R-22 refrigerant or flare parts.

When there is refrigerant leakage during installation, you must ventilate the area.

- ▶ Toxic gas may be generated when refrigerant gas contacts with fire.

If the power cable or cord is damaged, it should be replaced by manufacturer or qualified person. The electric work must be done by a certified person according to code and standard about electric installation, regulation for indoor wiring and installation manual. In addition, the electric work must be in compliance with rated electric specification.

- ▶ Voltage drop, shortage of supply voltage, incorrect power supply work and use of uncertified cables may result in electric shock or fire.

Arrange the cables between the DOAS Interface Module and outdoor unit so that the cover of electric part does not rise and then fix the cover of the electric box to the product firmly.

- ▶ If the cover is attached incompletely, a heat generation, electric shock or fire of the terminal may occur.

The Power supply to the kit should be through dedicated MCCB/ELB or ELCB.

- ▶ If dedicated MCCB/ELB or ELCB is not provided, electric shock or fire may occur because of overcurrent or leakage current.

Safety Information

FOR INSTALLATION



WARNING

Install the supplied cables firmly. Fix them securely so that external force is not applied to the terminal.

- ▶ If the connection or fixing is incomplete, heat generation, spark and fire may occur.

Make sure that the power for DOAS Interface Module is under maximum, and over minimum voltage.

- ▶ Failure to do so may result in product malfunction due to electrical component damage and functional degradation of a part.

Use rated copper wire for the power cable.

Make sure electric wiring is correctly connected.

- ▶ Failure to do so may result in fire with overheating.

Make sure there is no leakage of refrigerant gas after finishing installation.

- ▶ When leakage of refrigerant gas contacts with fire, toxic gas may be generated.

Wear protective equipment (such as safety gloves, goggles, and headgear) during installation and maintenance works. Installation/repair technicians may be injured if protective equipment is not properly equipped.

FOR INSTALLATION



CAUTION

Proper earthing should be done as per the rating.

- ▶ Do not connect the ground wire to the gas pipe, water pipe, lightning rod or a ground wire of a telephone.
- ▶ If the grounding is incomplete, electric shock may occur.

Follow the instructions in this manual to make sure that the condensed water dripping from the drain hose runs out properly and insulate the drain pipe so that dew condensation is not generated.

- ▶ If the drain work is incomplete, property damage may occur due to water leakage.

Install the power cable and communication cable of the DOAS Interface Module at least 3.28ft (1m) away from other electric appliances and 6.56ft (2m) away from lightning conductor.

- ▶ However, even 3.28ft (1m) away from an electric appliance, noise may be heard depending on radio wave condition.

Do not install the DOAS Interface Module in following places.

- ▶ **The place where much mineral oil, arsenic acid or steam exist.**
The resin parts may be burned, which can result in falling part or water leakage.
- ▶ **The place where corrosive gas such as sulfurous acid gas from an exhaust pipe or air outlet can be generated.**
The copper pipe or connection part may corrode, which may result in refrigerant leakage.
- ▶ **The place where there is a machine that generates electromagnetic waves.**
The control system may have a problem which can result in abnormal operation.
- ▶ **The place where inflammable gas can leak, carbon fiber or inflammable dust floats, or volatile flammables are handled.**
If the gas leaks and stays around the main valve of the product, fire may occur.
- ▶ **The place where indoor unit corrosion may occur such as seashore or spa.**
- ▶ **The place where external environment such as sunlight, rain, temperature, humidity, dust can directly affect the product.**
- ※ **The manufacturer is not responsible for the damage occurred by not keeping standard of the installation. (The cost of the service will be charged.)**

R-32 General Guidelines for Compliance

Case 1 : $m_c \leq 15.9$ kg

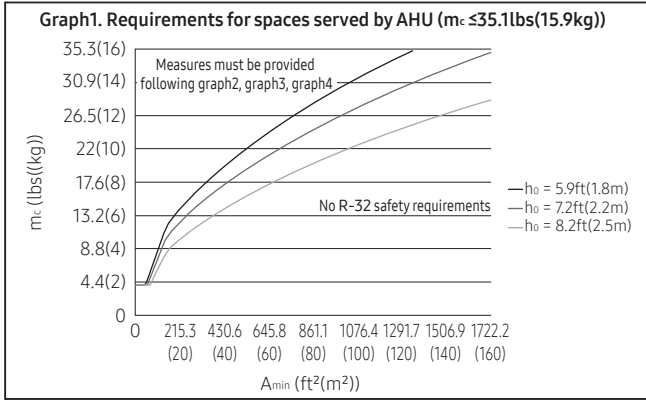

| m_c (lbs((kg)) | A_{min} (ft ² (m ²)) | | |
|------------------|---|---------------------------------|---------------------------------|
| | $h_0=5.9\text{ft}(1.8\text{m})$ | $h_0=7.2\text{ft}(2.2\text{m})$ | $h_0=8.2\text{ft}(2.5\text{m})$ |
| 4.41(2) | 77.5(7.2) | 63.5(5.9) | 56(5.2) |
| 5.51(2.5) | 96.9(9) | 79.7(7.4) | 70(6.5) |
| 6.61(3) | 116.3(10.8) | 95.8(8.9) | 84(7.8) |
| 7.72(3.5) | 136.7(12.7) | 110.9(10.3) | 98(9.1) |
| 8.82(4) | 163.6(15.2) | 127(11.8) | 111.9(10.4) |
| 9.92(4.5) | 207.7(19.3) | 143.2(13.3) | 125.9(11.7) |
| 11.02(5) | 256.2(23.8) | 171.1(15.9) | 139.9(13) |
| 12.13(5.5) | 310(28.8) | 207.7(19.3) | 160.4(14.9) |
| 13.23(6) | 369.2(34.3) | 246.5(22.9) | 190.5(17.7) |
| 15.33(6.5) | 432.7(40.2) | 289.5(26.9) | 223.9(20.8) |
| 17.43(7) | 502.7(46.7) | 335.8(31.2) | 260.5(24.2) |
| 19.53(7.5) | 576.9(53.6) | 385.3(35.8) | 299.2(27.8) |
| 21.64(8) | 656.6(61) | 439.2(40.8) | 340.1(31.6) |
| 23.74(8.5) | 740.6(68.8) | 496.2(46.1) | 384.3(35.7) |
| 25.84(9) | 831(77.2) | 555.4(51.6) | 430.6(40) |
| 27.94(9.5) | 925.7(86) | 618.9(57.5) | 480.1(44.6) |
| 29.05(10) | 1025.8(95.3) | 686.7(63.8) | 531.7(49.4) |
| 31.15(10.5) | 1131.3(105.1) | 756.7(70.3) | 585.6(54.4) |
| 32.25(11) | 1241.1(115.3) | 831(77.2) | 643.7(59.8) |
| 33.35(11.5) | 1356.3(126) | 908.5(84.4) | 702.9(65.3) |
| 34.46(12) | 1476.8(137.2) | 989.2(91.9) | 765.3(71.1) |
| 35.56(12.5) | 1602.7(148.9) | 1073.2(99.7) | 831(77.2) |
| 36.66(13) | 1734.1(161.1) | 1160.3(107.8) | 898.8(83.5) |
| 37.76(13.5) | 1869.7(173.7) | 1251.8(116.3) | 968.8(90) |
| 38.86(14) | 2010.7(186.8) | 1345.5(125) | 1041.9(96.8) |
| 39.97(14.5) | 2157.1(200.4) | 1443.4(134.1) | 1118.4(103.9) |
| 41.07(15) | 2308.9(214.5) | 1544.6(143.5) | 1196.9(111.2) |
| 42.17(15.5) | 2464.9(229) | 1650.1(153.3) | 1277.7(118.7) |
| 43.05(15.9) | 2594.1(241) | 1736.2(161.3) | 1344.4(124.9) |

m_c : Total charge of refrigerant in the system [lbs(kg)]

A_{min} : Minimum room area [ft²(m²)

R-32 General Guidelines for Compliance

Case2 (m ≤ 79.6 kg)

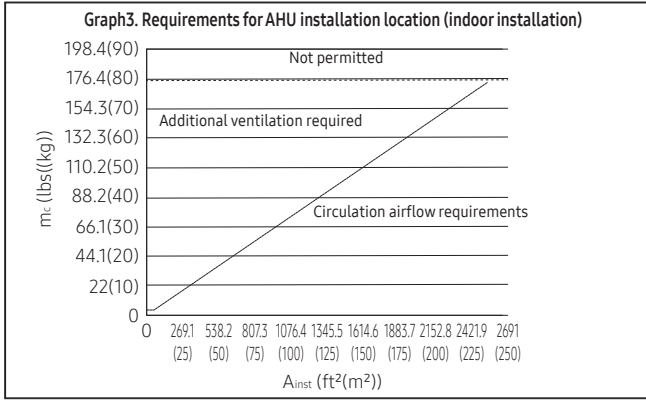

| A _{inst} (ft ² /m ²) | m _c (lbs/(kg)) |
|--|---------------------------|
| 64.6(6) | 4.4(2) |
| 107.6(10) | 7.3(3.3) |
| 161.5(15) | 11(5) |
| 215.3(20) | 14.8(6.7) |
| 269.1(25) | 18.5(8.4) |
| 322.9(30) | 22(10) |
| 376.7(35) | 25.8(11.7) |
| 430.6(40) | 29.5(13.4) |
| 484.4(45) | 33.3(15.1) |
| 538.2(50) | 37(16.8) |
| 592(55) | 40.8(18.5) |
| 645.8(60) | 44.3(20.1) |
| 699.7(65) | 48.1(21.8) |
| 753.5(70) | 51.8(23.5) |
| 807.3(75) | 55.6(25.2) |
| 861.1(80) | 59.3(26.9) |
| 914.9(85) | 63.1(28.6) |
| 968.8(90) | 66.6(30.2) |
| 1022.6(95) | 70.3(31.9) |
| 1076.4(100) | 74.1(33.6) |
| 1130.2(105) | 77.8(35.3) |
| 1184(110) | 81.6(37) |
| 1237.8(115) | 85.3(38.7) |
| 1291.7(120) | 88.8(40.3) |
| 1345.5(125) | 92.6(42) |
| 1399.3(130) | 96.3(43.7) |
| 1453.1(135) | 100.1(45.4) |
| 1506.9(140) | 103.8(47.1) |
| 1560.8(145) | 107.6(48.8) |
| 1614.6(150) | 111.1(50.4) |
| 1668.4(155) | 114.9(52.1) |
| 1722.2(160) | 118.6(53.8) |

| A _{inst} (ft ² /m ²) | m _c (lbs/(kg)) |
|--|---------------------------|
| 1776(165) | 122.4(55.5) |
| 1829.9(170) | 126.1(57.2) |
| 1883.7(175) | 129.9(58.9) |
| 1937.5(180) | 133.4(60.5) |
| 1991.3(185) | 137.1(62.2) |
| 2045.1(190) | 140.9(63.9) |
| 2099(195) | 144.6(65.6) |
| 2152.8(200) | 148.4(67.3) |
| 2206.6(205) | 152.1(69) |
| 2260.4(210) | 155.6(70.6) |
| 2314.2(215) | 159.4(72.3) |
| 2368.1(220) | 163.1(74) |
| 2421.9(225) | 166.9(75.7) |
| 2475.7(230) | 170.6(77.4) |
| 2529.5(235) | 174.4(79.1) |

A_{inst}: The minimum required area for AHU installation space (ft²/m²)

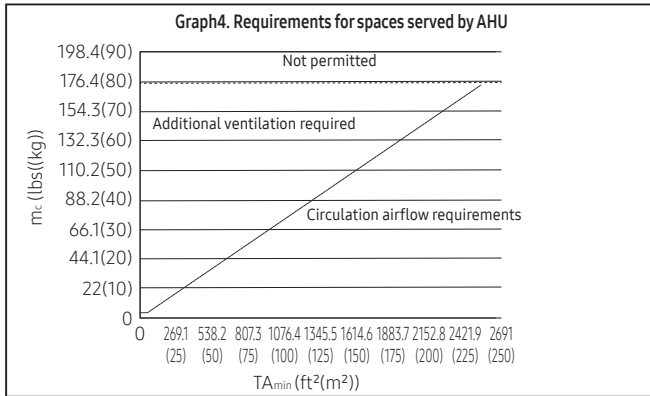

| TA _{min} (ft²(m²)) | m _c (lbs(kg)) |
|-----------------------------|--------------------------|
| 64.6(6) | 4.4(2) |
| 107.6(10) | 7.3(3.3) |
| 161.5(15) | 11(5) |
| 215.3(20) | 14.8(6.7) |
| 269.1(25) | 18.5(8.4) |
| 322.9(30) | 22(10) |
| 376.7(35) | 25.8(11.7) |
| 430.6(40) | 29.5(13.4) |
| 484.4(45) | 33.3(15.1) |
| 538.2(50) | 37(16.8) |
| 592(55) | 40.8(18.5) |
| 645.8(60) | 44.3(20.1) |
| 699.7(65) | 48.1(21.8) |
| 753.5(70) | 51.8(23.5) |
| 807.3(75) | 55.6(25.2) |
| 861.1(80) | 59.3(26.9) |
| 914.9(85) | 63.1(28.6) |
| 968.8(90) | 66.6(30.2) |
| 1022.6(95) | 70.3(31.9) |
| 1076.4(100) | 74.1(33.6) |
| 1130.2(105) | 77.8(35.3) |
| 1184(110) | 81.6(37) |
| 1237.8(115) | 85.3(38.7) |
| 1291.7(120) | 88.8(40.3) |
| 1345.5(125) | 92.6(42) |
| 1399.3(130) | 96.3(43.7) |
| 1453.1(135) | 100.1(45.4) |
| 1506.9(140) | 103.8(47.1) |
| 1560.8(145) | 107.6(48.8) |
| 1614.6(150) | 111.1(50.4) |
| 1668.4(155) | 114.9(52.1) |
| 1722.2(160) | 118.6(53.8) |
| 1776(165) | 122.4(55.5) |
| 1829.9(170) | 126.1(57.2) |
| 1883.7(175) | 129.9(58.9) |
| 1937.5(180) | 133.4(60.5) |
| 1991.3(185) | 137.1(62.2) |
| 2045.1(190) | 140.9(63.9) |

| TA _{min} (ft²(m²)) | m _c (lbs(kg)) |
|-----------------------------|--------------------------|
| 2099(195) | 144.6(65.6) |
| 2152.8(200) | 148.4(67.3) |
| 2206.6(205) | 152.1(69) |
| 2260.4(210) | 155.6(70.6) |
| 2314.2(215) | 159.4(72.3) |
| 2368.1(220) | 163.1(74) |
| 2421.9(225) | 166.9(75.7) |
| 2475.7(230) | 170.6(77.4) |
| 2529.5(235) | 174.4(79.1) |

TA_{min}: The required minimum area of the total conditioned space (ft²(m²))

R-32 General Guidelines for Compliance

※ Minimum Circulation airflow Calculation

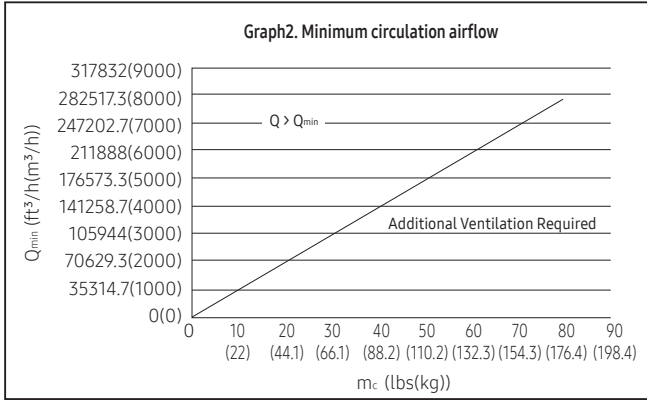

| m _c (lbs(kg)) | Q _{min} (ft ³ /h(m ³ /h)) |
|--------------------------|--|
| 0 | 0 |
| 1.1(0.5) | 1730.4(49) |
| 2.2(1) | 3460.8(98) |
| 3.3(1.5) | 5191.3(147) |
| 4.4(2) | 6921.7(196) |
| 5.5(2.5) | 8652.1(245) |
| 6.6(3) | 10386.2(294.1) |
| 7.7(3.5) | 12116.5(343.1) |
| 8.8(4) | 13846.9(392.1) |
| 9.9(4.5) | 15577.3(441.1) |
| 11(5) | 17307.7(490.1) |
| 12.1(5.5) | 19041.7(539.2) |
| 13.2(6) | 20772.1(588.2) |
| 14.3(6.5) | 22502.5(637.2) |
| 15.4(7) | 24232.9(686.2) |
| 16.5(7.5) | 25963.3(735.2) |
| 17.6(8) | 27693.7(784.3) |
| 18.7(8.5) | 29427.7(833.3) |
| 19.8(9) | 31158.1(882.3) |
| 20.9(9.5) | 32888.5(931.3) |
| 22(10) | 34619(980.3) |
| 23.1(10.5) | 36352.9(1029.4) |
| 24.3(11) | 38083.3(1078.4) |
| 25.4(11.5) | 39813.8(1127.4) |
| 26.5(12) | 41544.2(1176.4) |
| 27.6(12.5) | 43274.6(1225.4) |
| 28.7(13) | 45005.0(1274.5) |
| 29.8(13.5) | 46739(1323.5) |
| 30.9(14) | 48469.4(1372.5) |
| 32(14.5) | 50199.8(1421.5) |
| 33.1(15) | 51930.2(1470.5) |
| 34.2(15.5) | 53664.2(1519.6) |
| 35.3(16) | 55394.6(1568.6) |
| 36.4(16.5) | 57125(1617.6) |
| 37.5(17) | 58855.4(1666.6) |
| 38.6(17.5) | 60585.8(1715.6) |
| 39.7(18) | 62319.8(1764.7) |
| 40.8(18.5) | 64050.2(1813.7) |
| 41.9(19) | 65780.6(1862.7) |
| 43(19.5) | 67511(1911.7) |
| 44.1(20) | 69241.5(1960.7) |

| m _c (lbs(kg)) | Q _{min} (ft ³ /h(m ³ /h)) |
|--------------------------|--|
| 45.2(20.5) | 70975.4(2009.8) |
| 46.3(21) | 72705.8(2058.8) |
| 47.4(21.5) | 74436.3(2107.8) |
| 48.5(22) | 76166.7(2156.8) |
| 49.6(22.5) | 77897.1(2205.8) |
| 50.7(23) | 79631(2254.9) |
| 51.8(23.5) | 81361.5(2303.9) |
| 52.9(24) | 83091.9(2352.9) |
| 54(24.5) | 84822.3(2401.9) |
| 55.1(25) | 86552.7(2450.9) |
| 56.2(25.5) | 88286.7(2500) |
| 57.3(26) | 90017.1(2549) |
| 58.4(26.5) | 91747.5(2598) |
| 59.5(27) | 93477.9(2647) |
| 60.6(27.5) | 95208.3(2696) |
| 61.7(28) | 96938.8(2745) |
| 62.8(28.5) | 98672.7(2794.1) |
| 63.9(29) | 100403.1(2843.1) |
| 65(29.5) | 102133.5(2892.1) |
| 66.1(30) | 103864(2941.1) |
| 67.2(30.5) | 105594.4(2990.1) |
| 68.3(31) | 107328.3(3039.2) |
| 69.4(31.5) | 109058.8(3088.2) |
| 70.5(32) | 110789.2(3137.2) |
| 71.7(32.5) | 112519.6(3186.2) |
| 72.8(33) | 114250(3235.2) |
| 73.9(33.5) | 115984(3284.3) |
| 75(34) | 117714.4(3333.3) |
| 76.1(34.5) | 119444.8(3382.3) |
| 77.2(35) | 121175.2(3431.3) |
| 78.3(35.5) | 122905.6(3480.3) |
| 79.4(36) | 124639.6(3529.4) |
| 80.5(36.5) | 126370(3578.4) |
| 81.6(37) | 128100.4(3627.4) |
| 82.7(37.5) | 129830.8(3676.4) |
| 83.8(38) | 131561.3(3725.4) |
| 84.9(38.5) | 133295.2(3774.5) |
| 86(39) | 135025.6(3823.5) |
| 87.1(39.5) | 136756(3872.5) |
| 88.2(40) | 138486.5(3921.5) |
| 89.3(40.5) | 140216.9(3970.5) |

| m _c (lbs(kg)) | Q _{min} (ft ³ /h(m ³ /h)) |
|--------------------------|--|
| 90.4(41) | 141950.8(4019.6) |
| 91.5(41.5) | 143681.3(4068.6) |
| 92.6(42) | 145411.7(4117.6) |
| 93.7(42.5) | 147142.1(4166.6) |
| 94.8(43) | 148872.5(4215.6) |
| 95.9(43.5) | 150606.5(4264.7) |
| 97(44) | 152336.9(4313.7) |
| 98.1(44.5) | 154067.3(4362.7) |
| 99.2(45) | 155797.7(4411.7) |
| 100.3(45.5) | 157528.1(4460.7) |
| 101.4(46) | 159262.1(4509.8) |
| 102.5(46.5) | 160992.5(4558.8) |
| 103.6(47) | 162722.9(4607.8) |
| 104.7(47.5) | 164453.3(4656.8) |
| 105.8(48) | 166183.8(4705.8) |
| 106.9(48.5) | 167917.7(4754.9) |
| 108(49) | 169648.1(4803.9) |
| 109.1(49.5) | 171378.5(4852.9) |
| 110.2(50) | 173109(4901.9) |
| 111.3(50.5) | 174839.4(4950.9) |
| 112.4(51) | 176573.3(5000) |
| 113.5(51.5) | 178303.8(5049) |
| 114.6(52) | 180034.2(5098) |
| 115.7(52.5) | 181764.6(5147) |
| 116.8(53) | 183495(5196) |
| 117.9(53.5) | 185225.4(5245) |
| 119(54) | 186959.4(5294.1) |
| 120.2(54.5) | 188689.8(5343.1) |
| 121.3(55) | 190420.2(5392.1) |
| 122.4(55.5) | 192150.6(5441.1) |
| 123.5(56) | 193881.1(5490.1) |
| 124.6(56.5) | 195615(5539.2) |
| 125.7(57) | 197345.4(5588.2) |
| 126.8(57.5) | 199075.8(5637.2) |
| 127.9(58) | 200806.3(5686.2) |
| 129(58.5) | 202536.7(5735.2) |
| 130.1(59) | 204270.6(5784.3) |
| 131.2(59.5) | 206001(5833.3) |
| 132.3(60) | 207731.5(5882.3) |
| 133.4(60.5) | 209461.9(5931.3) |
| 134.5(61) | 211192.3(5980.3) |

| m _c (lbs(kg)) | Q _{min} (ft ³ /h(m ³ /h)) |
|--------------------------|--|
| 135.6(61.5) | 212926.3(6029.4) |
| 136.7(62) | 214656.7(6078.4) |
| 137.8(62.5) | 216387.1(6127.4) |
| 138.9(63) | 218117.5(6176.4) |
| 140(63.5) | 219847.9(6225.4) |
| 141.1(64) | 221578.3(6274.5) |
| 142.2(64.5) | 223312.3(6323.5) |
| 143.3(65) | 225042.7(6372.5) |
| 144.4(65.5) | 226773.1(6421.5) |
| 145.5(66) | 228503.6(6470.5) |
| 146.6(66.5) | 230237.5(6519.6) |
| 147.7(67) | 231967.9(6568.6) |
| 148.8(67.5) | 233698.3(6617.6) |
| 149.9(68) | 235428.8(6666.6) |
| 151(68.5) | 237159.2(6715.6) |
| 152.1(69) | 238893.1(6764.7) |
| 153.2(69.5) | 240623.5(6813.7) |
| 154.3(70) | 242354(6862.7) |
| 155.4(70.5) | 244084.4(6911.7) |
| 156.5(71) | 245814.8(6960.7) |
| 157.6(71.5) | 247548.8(7009.8) |
| 158.7(72) | 249279.2(7058.8) |
| 159.8(72.5) | 251009.6(7107.8) |
| 160.9(73) | 252740(7156.8) |
| 162(73.5) | 254470.4(7205.8) |
| 163.1(74) | 256204.4(7254.9) |
| 164.2(74.5) | 257934.8(7303.9) |
| 165.3(75) | 259665.2(7352.9) |
| 166.4(75.5) | 261395.6(7401.9) |
| 167.5(76) | 263126.1(7450.9) |
| 168.6(76.5) | 264860(7500) |
| 169.7(77) | 266590.4(7549) |
| 170.8(77.5) | 268320.8(7598) |
| 172(78) | 270051.3(7647) |
| 173.1(78.5) | 271781.7(7696) |
| 174.2(79) | 273512.1(7745) |
| 175.3(79.5) | 275246(7794.1) |
| 176.4(80) | 276976.5(7843.1) |

Q_{min}: Minimum circulation airflow rate

Name of each part and product dimension

Name of each part and product dimension

Control assembly (Control part)

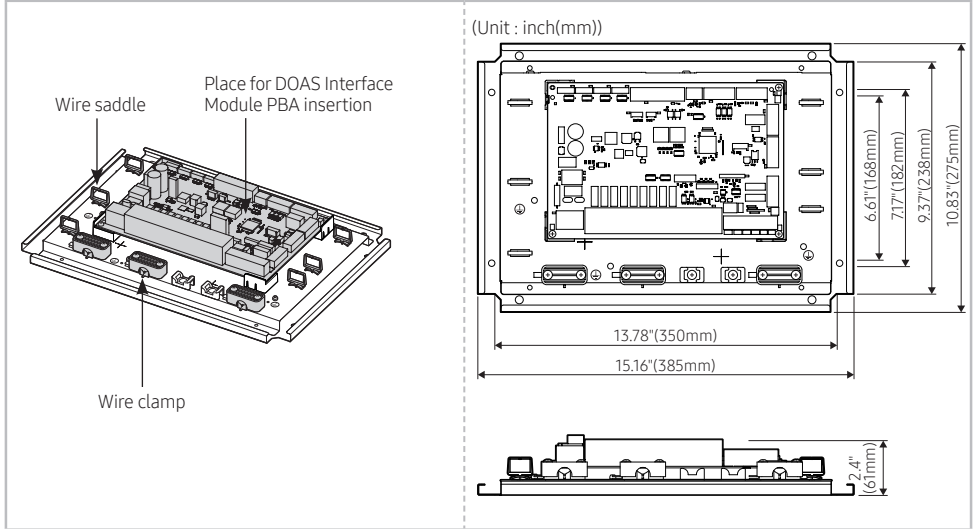

EEV Assembly (Electronic Expansion Valve): Accessory (Ordered separately)



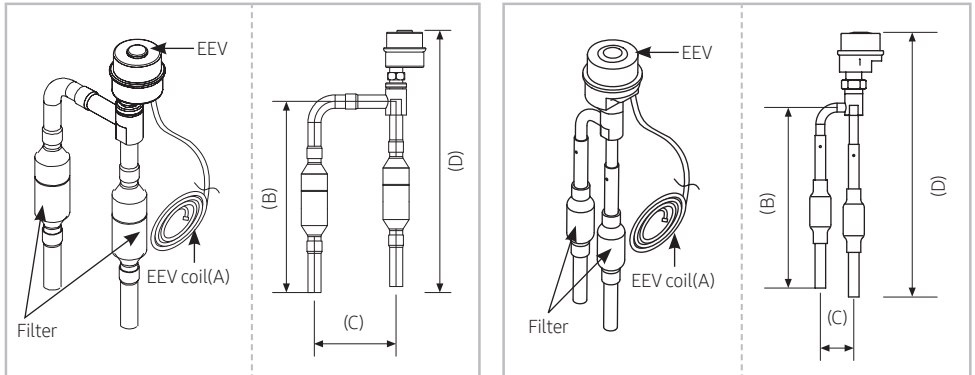

For detailed information of EEV installation, refer to the installation manual of EEV Assembly which you need to purchase additionally. (Model : V1EEVK05UC, V1EEVK04UC, V1EEVK03UC, V1EEVK02UC, V1EEVK01UC)



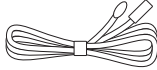
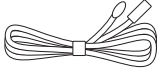

| MODEL | A (ft(m)) | B (inch(mm)) | C (inch(mm)) | D (inch(mm)) |
|------------|------------|--------------|--------------|--------------|
| V1EEVK05UC | 22.97' (7) | 7.28"(185) | 3.03"(77) | 10.04"(255) |
| V1EEVK04UC | 22.97' (7) | 7.28"(185) | 3.03"(77) | 10.04"(255) |
| V1EEVK03UC | 6.56' (2) | 6.57"(167) | 1.34"(34) | 9.65"(245) |
| V1EEVK02UC | 6.56' (2) | 7.28"(185) | 2.91"(74) | 9.96"(253) |
| V1EEVK01UC | 3.28' (1) | 6.38"(162) | 1.18"(30) | 9.33"(237) |

Parts

Accessories (supplied)

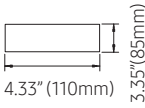
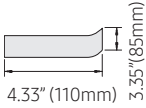
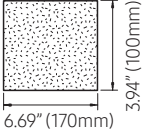
| Name | Pipe inlet/outlet sensor Room temperature sensor 32.8'(10m) | Discharge air temperature sensor 32.8'(10m) | Inlet sensor holder (OD Ø 0.27"(6.8mm)) | Outlet sensor holder (OD Ø 0.31"(7.8mm)) | Sensor fixing spring |
|----------|---|---|---|---|--|
| Quantity | 1 | 1 | 1 | 1 | 2 |
| Shape |  |  |  |  |  |

| Name | Aluminum tape | Rubber tape | Insulator | Cable tie |
|----------|---|---|---|--|
| Quantity | 4 | 2 | 2 | 8 |
| Shape |  |  |  |  |

- ※ It is not mandatory to connect discharge air temperature sensor.
If discharge air temperature control is required, install the sensor at the air outlet and set SEG 21 of 01 series product option to "1."

Additional accessory (not included)

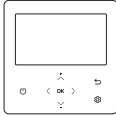
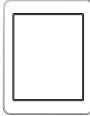
| * Programmable Wired Controller (VSTAT04P-1) | * Wired controller (VSTAT02P-1) |
|--|--|
| 1 | 1 |
|  |  |

- ※ Wired controllers are purchased separately.
- ※ Other controllers for R-32 indoor units may be compatible. Refer to wired controller supporting documents for details.

Checking before using a DOAS Interface Module

Structure diagram of a DOAS Interface Module

Outdoor unit

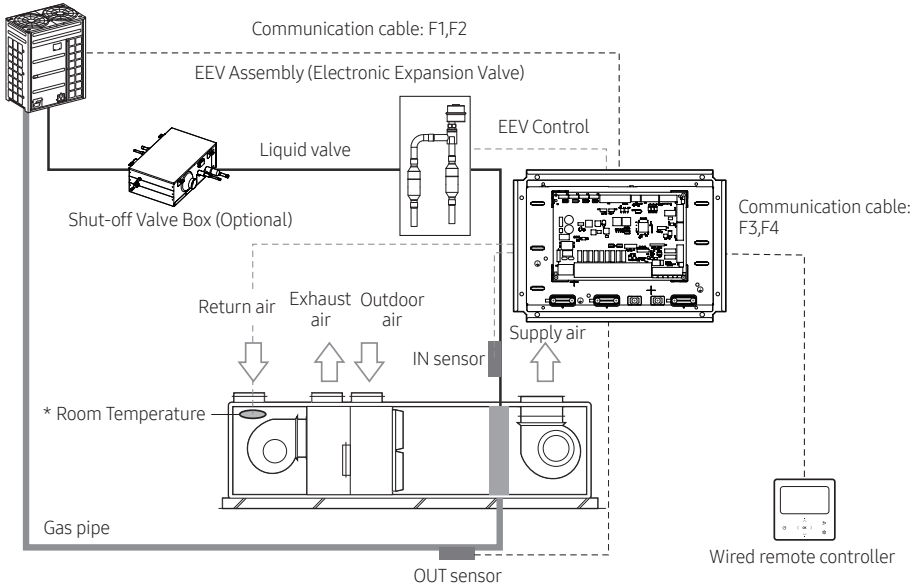

Installing a DOAS Interface Module

Installing Control assembly

1. Check the installation location of Control assembly.

- ▶ You can choose either indoor unit attachment type or indoor unit separation type depending on the installation environment.

2. Make sure the location has waterproof and fire prevention structure.

- ▶ Make sure that the Control assembly is not exposed to sunlight by covering with a case which has waterproof and fire prevention structure.

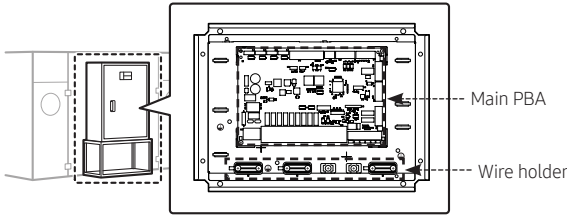

Functions of Control assembly

- ▶ Control assembly adjusts EEV for refrigerant flow rate and performs control functions through communication with an indoor unit or wired remote controller.
- ▶ The contact signal for indoor unit fan operation is sent from Control assembly. When indoor unit is in Cool/Heat/Fan mode, terminal block B1~B8 will output contact signal to turn the fan on. At this time, the output is contact signal and not be used for power supply of motor. (Refer to p.25)
- ▶ The terminal block B20/B21 will receive the signal for fan operation status and the signal is the input signal which DOAS Interface Module control part receives. At this time, the input signal should be input as only OPEN/SHORT signal not the signal that has separate voltage level. (Refer to p.13, 19)
 - When the fan operates normally: The terminal block B20/B21 are SHORT status.
 - When the fan does not operate: The terminal block B20/B21 are OPEN status.
 - Set SEG 21 of installation option 05 series to '1(Use)' to use fan feedback for system protection. (Refer to p. 49)
- ▶ The terminal block B11/B12 is output defrost signal. (There exist some time delay.)
 - When installing a defrost bypass valve, set SEG22 of 05 series installation option as "1".
- ▶ Connect 24V to the terminal block 1(L)/2(N).
- ▶ The terminal block of communication cable (F1, F2) is connected with communication of Outdoor Unit. When installing additional DOAS Interface Module, the communication (F1, F2) should be connected with the communication (F1,F2) of DOAS Interface Module which is additionally installed.
- ▶ The communication cable (F3, F4) is the communication group of wired remote controller.
- ▶ For capacity setting, refer to SEG20 of 05 series in installation option section. (Refer to p.49)
- ▶ Connect room temperature sensor and discharge temperature sensor (optional).
 - When using the PT1000Ω sensor, connect to the terminal block B24/B25/B26.
 - Set the types of room temperature sensor and discharge temperature sensor in SEG24 of 05 series installation option.

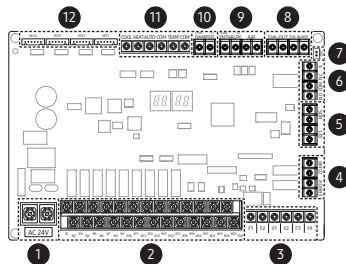

| No. | CONNECTOR | SIGNAL | FUNCTION | CONTACT SHORT | CONTACT OPEN | *SCREW | | | | |
|-----|-------------|-------------|----------------------|---|---------------------------|---------------------------|------|---|---|------|
| 1 | CN166 | - | AC24V/60Hz | - | - | M4 | | | | |
| 2 | TB800 | B1 | *DRY CONTACT | FAN HIGH | FAN STEP HIGH ON | FAN OFF | M3.5 | | | |
| | | B2 | *DRY CONTACT | FAN MID | FAN STEP MID ON | FAN OFF | | | | |
| | | B3 | *DRY CONTACT | FAN LOW | FAN STEP LOW ON | FAN OFF | | | | |
| | | B4 | *DRY CONTACT | FAN OUT | FAN ON | FAN OFF | | | | |
| | | B5 | *DRY CONTACT | HEATER | HEATER ON | HEATER OFF | | | | |
| | | B6 | *DRY CONTACT | DEFROST | DEFROST ON | DEFROST OFF | | | | |
| | | B7 | *DRY CONTACT | COOL_T | COOL THERMO ON | COOL THERMO OFF | | | | |
| | | B8 | *DRY CONTACT | THERMO | THERMO ON | THERMO OFF | | | | |
| | | B9 | *DRY CONTACT | OPERATION | OPERATION ON | OPERATION OFF | | | | |
| | | B10 | - | - | - | - | | | | |
| | | B11 | - | - | - | - | | | | |
| | | B12 | ZERO VOLTAGE CONTACT | FAN CHECK ON | FAN CHECK ON | FAN CHECK OFF | | | | |
| | | B13 | ZERO VOLTAGE CONTACT | FREE COOL ON | FREE COOL ON | FREE COOL OFF | | | | |
| | | B14 | INPUT | PT1000 | - | - | | | | |
| | | B15 | INPUT | | | | | | | |
| | | B16 | COM | | | | | | | |
| | | 3 | CN301 | F1 | - | IN-OUT COMMUNICATION | | - | - | M3.5 |
| | | | | F2 | - | | | - | - | |
| V1 | DC | | | DC 12V | - | - | | | | |
| V2 | | | | COM | - | - | | | | |
| F3 | - | | | WIRED REMOTE COMMUNICATION | - | - | | | | |
| F4 | - | | | | - | - | | | | |
| 4 | TB950 | ERROR | *DRY CONTACT | ERROR CHECK OUT | ERROR OCCURRED | ERROR OFF | M3 | | | |
| | | COMP | *DRY CONTACT | COMP CHECK OUT | Depends on Install Option | Depends on Install Option | | | | |
| 5 | TB810 | EXT | INPUT | EXTERNAL CONTROL INPUT | - | - | M3 | | | |
| | | | COM | | - | - | | | | |
| | | RDS | ZERO VOLTAGE CONTACT | Refrigerant Detection System INPUT | - | - | | | | |
| 6 | TB580 | NO | *DRY CONTACT | R-32 CHECK NORMAL OPEN OUT | - | - | M3 | | | |
| | | COM | | R-32 CHECK COM | - | - | | | | |
| | | NC | | R-32 CHECK NORMAL CLOSE OUT | - | - | | | | |
| | | X | | - | - | - | | | | |
| 7 | CN401 | THERMISTOR | DISCHARGE SENSOR | - | - | - | | | | |
| | | COM | | - | - | | | | | |
| 8 | TB400 | EVA-IN-MID | THERMISTOR | EVA IN SENSOR | - | - | M3 | | | |
| | | COM | COM | | - | - | | | | |
| | | EVA-OUT | THERMISTOR | EVA OUT SENSOR | - | - | | | | |
| 9 | TB401 | IN-TEMP | THERMISTOR | AIR SENSOR | - | - | M3 | | | |
| | | COM | COM | | - | - | | | | |
| | | ENTHALPY(+) | LEVEL IN | Current-output sensor (Enthalpy or Temperature) | - | - | | | | |
| 10 | CN650 | DAMPER(+) | LEVEL OUT | DAMPER ANALOG LEVEL | - | - | M3 | | | |
| | | COM | COM | | - | - | | | | |
| 11 | CN805 | COM | COM | SIMPLE BMS TEMP IN | - | - | M3.5 | | | |
| | | TEMP | LEVEL IN | | - | - | | | | |
| | | COM | COM | - | - | | | | | |
| | | AUTO | ZERO VOLTAGE CONTACT | SIMPLE BMS MODE IN | - | - | | | | |
| | | HEAT COOL | | | - | - | | | | |
| 12 | CN901-CN904 | - | EEV | - | - | - | | | | |

※ Rated current capacity for dry contacts: 250 VAC / 1A

※ Use ring terminals that fit the screw

Installing a DOAS Interface Module

Simple BMS

Simple BMS setting

- ▶ Simple BMS can control Room temperature or Discharge temperature by setting SEG17 of 05 series Installation option.
 - For controlling Room temperature : SEG17 of 05 series Installation option → 0
 - For controlling Discharge temperature : SEG17 of 05 series Installation option → 1
 - For controlling Target Pressure : SEG17 of 05 series Installation option → 2
- ▶ Discharge temperature can be set by DMS.
- ▶ Simple BMS control is not influenced by DMS's restrictions on operation mode, set temperature or remote controller usage.
- ▶ If you want to set Room temperature or Discharge temperature by using Simple BMS, setting Buzzer control option as "Disuse buzzer" is recommended.

Circuit diagram of Simple BMS

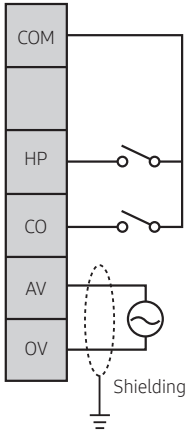

Ex) setting up 71.6°F (22°C) (Simple BMS : Room temperature setting)

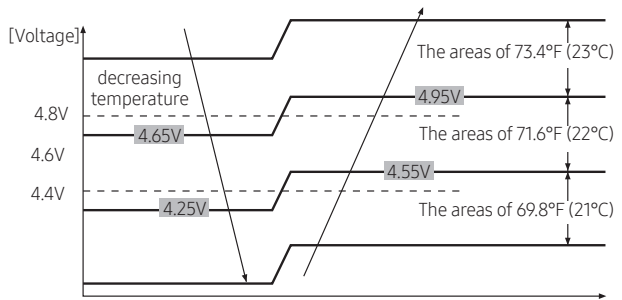

- Hysteresis is applied to the end of voltage range in order to stabilize the analog input.
The amount of Hysteresis
 - Room temperature setting: 0.15 V
 - Discharge temperature setting: 0.08 V

Operational Voltage range against Setting temperature

► Room temperature setting (05 Series Install Option SEG17=0)

| Simple BMS Voltage Range | Set Temperature | |
|--------------------------|-----------------|-----------------|
| | Heating | Cooling |
| 10.0 V ~ 9.6 V | 86.0 °F (30 °C) | 86.0 °F (30 °C) |
| 9.6 V ~ 9.2 V | 86.0 °F (30 °C) | 86.0 °F (30 °C) |
| 9.2 V ~ 8.8 V | 86.0 °F (30 °C) | 86.0 °F (30 °C) |
| 8.8 V ~ 8.4 V | 86.0 °F (30 °C) | 86.0 °F (30 °C) |
| 8.4 V ~ 8.0 V | 86.0 °F (30 °C) | 86.0 °F (30 °C) |
| 8.0 V ~ 7.6 V | 86.0 °F (30 °C) | 86.0 °F (30 °C) |
| 7.6 V ~ 7.2 V | 84.2 °F (29 °C) | 84.2 °F (29 °C) |
| 7.2 V ~ 6.8 V | 82.4 °F (28 °C) | 82.4 °F (28 °C) |
| 6.8 V ~ 6.4 V | 80.6 °F (27 °C) | 80.6 °F (27 °C) |
| 6.4 V ~ 6.0 V | 78.8 °F (26 °C) | 78.8 °F (26 °C) |
| 6.0 V ~ 5.6 V | 77.0 °F (25 °C) | 77.0 °F (25 °C) |
| 5.6 V ~ 5.2 V | 75.2 °F (24 °C) | 75.2 °F (24 °C) |
| 5.2 V ~ 4.8 V | 73.4 °F (23 °C) | 73.4 °F (23 °C) |
| 4.8 V ~ 4.4 V | 71.6 °F (22 °C) | 71.6 °F (22 °C) |
| 4.4 V ~ 4.0 V | 69.8 °F (21 °C) | 69.8 °F (21 °C) |
| 4.0 V ~ 3.6 V | 68.0 °F (20 °C) | 68.0 °F (20 °C) |
| 3.6 V ~ 3.2 V | 66.2 °F (19 °C) | 66.2 °F (19 °C) |
| 3.2 V ~ 2.8 V | 64.4 °F (18 °C) | 64.4 °F (18 °C) |
| 2.8 V ~ 2.4 V | 64.4 °F (18 °C) | 64.4 °F (18 °C) |
| 2.4 V ~ 2.0 V | 64.4 °F (18 °C) | 64.4 °F (18 °C) |
| 2.0 V ~ 1.6 V | 64.4 °F (18 °C) | 64.4 °F (18 °C) |
| 1.6 V ~ 1.2 V | 64.4 °F (18 °C) | 64.4 °F (18 °C) |
| 1.2 V ~ 0.8 V | 64.4 °F (18 °C) | 64.4 °F (18 °C) |
| 0.8 V ~ 0.4 V | 64.4 °F (18 °C) | 64.4 °F (18 °C) |
| 0.4 V ~ 0.0 V | 64.4 °F (18 °C) | 64.4 °F (18 °C) |

► Room temperature setting in case of DOAS setting (05 Series Install Option SEG17=0, DOAS setting in 02 Series Install Option SEG24)

| Simple BMS Voltage Range | Set Temperature | |
|--------------------------|-----------------|-----------------|
| | Heating | Cooling |
| 10.0 V ~ 9.6 V | 86 °F (30 °C) | 86 °F (30 °C) |
| 9.6 V ~ 9.2 V | 86 °F (30 °C) | 86 °F (30 °C) |
| 9.2 V ~ 8.8 V | 86 °F (30 °C) | 86 °F (30 °C) |
| 8.8 V ~ 8.4 V | 84.2 °F (29 °C) | 84.2 °F (29 °C) |
| 8.4 V ~ 8.0 V | 82.4 °F (28 °C) | 82.4 °F (28 °C) |
| 8.0 V ~ 7.6 V | 80.6 °F (27 °C) | 80.6 °F (27 °C) |
| 7.6 V ~ 7.2 V | 78.8 °F (26 °C) | 78.8 °F (26 °C) |
| 7.2 V ~ 6.8 V | 77.0 °F (25 °C) | 77.0 °F (25 °C) |
| 6.8 V ~ 6.4 V | 75.2 °F (24 °C) | 75.2 °F (24 °C) |
| 6.4 V ~ 6.0 V | 73.4 °F (23 °C) | 73.4 °F (23 °C) |
| 6.0 V ~ 5.6 V | 71.6 °F (22 °C) | 71.6 °F (22 °C) |
| 5.6 V ~ 5.2 V | 69.8 °F (21 °C) | 69.8 °F (21 °C) |
| 5.2 V ~ 4.8 V | 68.0 °F (20 °C) | 68.0 °F (20 °C) |
| 4.8 V ~ 4.4 V | 66.2 °F (19 °C) | 66.2 °F (19 °C) |
| 4.4 V ~ 4.0 V | 64.4 °F (18 °C) | 64.4 °F (18 °C) |
| 4.0 V ~ 3.6 V | 62.6 °F (17 °C) | 62.6 °F (17 °C) |
| 3.6 V ~ 3.2 V | 60.8 °F (16 °C) | 60.8 °F (16 °C) |
| 3.2 V ~ 2.8 V | 59.0 °F (15 °C) | 59.0 °F (15 °C) |
| 2.8 V ~ 2.4 V | 57.2 °F (14 °C) | 57.2 °F (14 °C) |
| 2.4 V ~ 2.0 V | 55.4 °F (13 °C) | 55.4 °F (13 °C) |
| 2.0 V ~ 1.6 V | 53.6 °F (12 °C) | 53.6 °F (12 °C) |
| 1.6 V ~ 1.2 V | 51.8 °F (11 °C) | 51.8 °F (11 °C) |
| 1.2 V ~ 0.8 V | 50.0 °F (10 °C) | 50.0 °F (10 °C) |
| 0.8 V ~ 0.4 V | 50.0 °F (10 °C) | 50.0 °F (10 °C) |
| 0.4 V ~ 0.0 V | 50.0 °F (10 °C) | 50.0 °F (10 °C) |

Installing a DOAS Interface Module

▶ Discharge temperature setting (05 Series Install Option SEG17=1)

| Simple BMS Voltage Range | Set Temperature | |
|--------------------------|-------------------|-------------------|
| | Heating | Cooling |
| 10.00 V ~ 9.75 V | 109.40 °F (43 °C) | 109.40 °F (43 °C) |
| 9.75 V ~ 9.50 V | 107.60 °F (42 °C) | 107.60 °F (42 °C) |
| 9.50 V ~ 9.25 V | 105.80 °F (41 °C) | 105.80 °F (41 °C) |
| 9.25 V ~ 9.00 V | 104.00 °F (40 °C) | 104.00 °F (40 °C) |
| 9.00 V ~ 8.75 V | 102.20 °F (39 °C) | 102.20 °F (39 °C) |
| 8.75 V ~ 8.50 V | 100.40 °F (38 °C) | 100.40 °F (38 °C) |
| 8.50 V ~ 8.25 V | 98.60 °F (37 °C) | 98.60 °F (37 °C) |
| 8.25 V ~ 8.00 V | 96.80 °F (36 °C) | 96.80 °F (36 °C) |
| 8.00 V ~ 7.75 V | 95.00 °F (35 °C) | 95.00 °F (35 °C) |
| 7.75 V ~ 7.50 V | 93.20 °F (34 °C) | 93.20 °F (34 °C) |
| 7.50 V ~ 7.25 V | 91.40 °F (33 °C) | 91.40 °F (33 °C) |
| 7.25 V ~ 7.00 V | 89.60 °F (32 °C) | 89.60 °F (32 °C) |
| 7.00 V ~ 6.75 V | 87.80 °F (31 °C) | 87.80 °F (31 °C) |
| 6.75 V ~ 6.50 V | 86.00 °F (30 °C) | 86.00 °F (30 °C) |
| 6.50 V ~ 6.25 V | 84.20 °F (29 °C) | 84.20 °F (29 °C) |
| 6.25 V ~ 6.00 V | 82.40 °F (28 °C) | 82.40 °F (28 °C) |
| 6.00 V ~ 5.75 V | 80.60 °F (27 °C) | 80.60 °F (27 °C) |
| 5.75 V ~ 5.50 V | 78.80 °F (26 °C) | 78.80 °F (26 °C) |
| 5.50 V ~ 5.25 V | 77.00 °F (25 °C) | 77.00 °F (25 °C) |
| 5.25 V ~ 5.00 V | 75.20 °F (24 °C) | 75.20 °F (24 °C) |
| 5.00 V ~ 4.75 V | 73.40 °F (23 °C) | 73.40 °F (23 °C) |
| 4.75 V ~ 4.50 V | 71.60 °F (22 °C) | 71.60 °F (22 °C) |
| 4.50 V ~ 4.25 V | 69.80 °F (21 °C) | 69.80 °F (21 °C) |
| 4.25 V ~ 4.00 V | 68.00 °F (20 °C) | 68.00 °F (20 °C) |
| 4.00 V ~ 3.75 V | 66.20 °F (19 °C) | 66.20 °F (19 °C) |
| 3.75 V ~ 3.50 V | 64.40 °F (18 °C) | 64.40 °F (18 °C) |
| 3.50 V ~ 3.25 V | 62.60 °F (17 °C) | 62.60 °F (17 °C) |
| 3.25 V ~ 3.00 V | 60.80 °F (16 °C) | 60.80 °F (16 °C) |
| 3.00 V ~ 2.75 V | 59.00 °F (15 °C) | 59.00 °F (15 °C) |
| 2.75 V ~ 2.50 V | 57.20 °F (14 °C) | 57.20 °F (14 °C) |
| 2.50 V ~ 2.25 V | 55.40 °F (13 °C) | 55.40 °F (13 °C) |
| 2.25 V ~ 2.00 V | 53.60 °F (12 °C) | 53.60 °F (12 °C) |
| 2.00 V ~ 1.75 V | 51.80 °F (11 °C) | 51.80 °F (11 °C) |
| 1.75 V ~ 1.50 V | 50.00 °F (10 °C) | 50.00 °F (10 °C) |
| 1.50 V ~ 1.25 V | 48.20 °F (9 °C) | 48.20 °F (9 °C) |
| 1.25 V ~ 1.00 V | 46.40 °F (8 °C) | 46.40 °F (8 °C) |
| 1.00 V ~ 0.75 V | 46.40 °F (8 °C) | 46.40 °F (8 °C) |
| 0.75 V ~ 0.50 V | 46.40 °F (8 °C) | 46.40 °F (8 °C) |
| 0.50 V ~ 0.25 V | 46.40 °F (8 °C) | 46.40 °F (8 °C) |
| 0.25 V ~ 0.00 V | 46.40 °F (8 °C) | 46.40 °F (8 °C) |



• Range of Discharge temperature setting

- Cooling : 46.5 °F (8 °C) ~ 77.0 °F (25 °C)

- Heating : 64.4 °F (18 °C) ~ 109.4 °F (43 °C)

- If the voltage value is beyond the range of discharge temperature setting, the temperature is controlled by maximum/minimum value which meets the setting range.

(Ex : The voltage value of cooling discharge temperature 86 °F (30 °C) → the controlled value : 77 °F (25 °C))

► Target Pressure Setting (05 Series Install Option SEG17=2)

| Simple BMS Voltage Range | Set Refrigerant Pressure | |
|--------------------------|------------------------------------|--------------------------------------|
| | Heating (Condensing Pressure) | Cooling (Evaporating Pressure) |
| 10.00 V ~ 9.75 V | 33kg/cm ² G (469psig) | 6.2kg/cm ² G (88.2psig) |
| 9.75 V ~ 9.50 V | 32.5kg/cm ² G (462psig) | 6.4kg/cm ² G (91psig) |
| 9.50 V ~ 9.25 V | 32kg/cm ² G (455psig) | 6.6kg/cm ² G (93.9psig) |
| 9.25 V ~ 9.00 V | 31.5kg/cm ² G (448psig) | 6.8kg/cm ² G (96.7psig) |
| 9.00 V ~ 8.75 V | 31kg/cm ² G (441psig) | 7kg/cm ² G (99.6psig) |
| 8.75 V ~ 8.50 V | 30.5kg/cm ² G (434psig) | 7.2kg/cm ² G (102.4psig) |
| 8.50 V ~ 8.25 V | 30kg/cm ² G (427psig) | 7.4kg/cm ² G (105.3psig) |
| 8.25 V ~ 8.00 V | 29.5kg/cm ² G (420psig) | 7.6kg/cm ² G (108.1psig) |
| 8.00 V ~ 7.75 V | 29kg/cm ² G (412psig) | 7.8kg/cm ² G (110.9psig) |
| 7.75 V ~ 7.50 V | 28.5kg/cm ² G (405psig) | 8kg/cm ² G (113.8psig) |
| 7.50 V ~ 7.25 V | 28kg/cm ² G (398psig) | 8.2kg/cm ² G (116.6psig) |
| 7.25 V ~ 7.00 V | 27.5kg/cm ² G (391psig) | 8.4kg/cm ² G (119.5psig) |
| 7.00 V ~ 6.75 V | 27kg/cm ² G (384psig) | 8.6kg/cm ² G (122.3psig) |
| 6.75 V ~ 6.50 V | 26.5kg/cm ² G (377psig) | 8.8kg/cm ² G (125.2psig) |
| 6.50 V ~ 6.25 V | 26kg/cm ² G (370psig) | 9kg/cm ² G (128psig) |
| 6.25 V ~ 6.00 V | 25.5kg/cm ² G (363psig) | 9.2kg/cm ² G (130.9psig) |
| 6.00 V ~ 5.75 V | 25kg/cm ² G (356psig) | 9.4kg/cm ² G (133.7psig) |
| 5.75 V ~ 5.50 V | 24.5kg/cm ² G (348psig) | 9.6kg/cm ² G (136.5psig) |
| 5.50 V ~ 5.25 V | 24kg/cm ² G (341psig) | 9.8kg/cm ² G (139.4psig) |
| 5.25 V ~ 5.00 V | 23.5kg/cm ² G (334psig) | 10kg/cm ² G (142.2psig) |
| 5.00 V ~ 4.75 V | 23kg/cm ² G (327psig) | 10.2kg/cm ² G (145.1psig) |
| 4.75 V ~ 4.50 V | 22.5kg/cm ² G (320psig) | 10.4kg/cm ² G (147.9psig) |
| 4.50 V ~ 4.25 V | 22kg/cm ² G (313psig) | 10.6kg/cm ² G (150.8psig) |
| 4.25 V ~ 4.00 V | 21.5kg/cm ² G (306psig) | 10.8kg/cm ² G (153.6psig) |
| 4.00 V ~ 3.75 V | 21kg/cm ² G (299psig) | 11kg/cm ² G (156.5psig) |
| 3.75 V ~ 3.50 V | 20.5kg/cm ² G (292psig) | 11.2kg/cm ² G (159.3psig) |
| 3.50 V ~ 3.25 V | 20kg/cm ² G (284psig) | 11.4kg/cm ² G (162.1psig) |
| 3.25 V ~ 3.00 V | 19.5kg/cm ² G (277psig) | 11.6kg/cm ² G (165psig) |
| 3.00 V ~ 2.75 V | 19kg/cm ² G (270psig) | 11.8kg/cm ² G (167.8psig) |
| 2.75 V ~ 2.50 V | 18.5kg/cm ² G (263psig) | 12kg/cm ² G (170.7psig) |
| 2.50 V ~ 2.25 V | 18kg/cm ² G (256psig) | 12.2kg/cm ² G (173.5psig) |
| 2.25 V ~ 2.00 V | 17.5kg/cm ² G (249psig) | 12.4kg/cm ² G (176.4psig) |
| 2.00 V ~ 1.75 V | 17kg/cm ² G (242psig) | 12.6kg/cm ² G (179.2psig) |
| 1.75 V ~ 1.50 V | 16.5kg/cm ² G (235psig) | 12.8kg/cm ² G (182.1psig) |
| 1.50 V ~ 1.25 V | 16kg/cm ² G (228psig) | 13kg/cm ² G (184.9psig) |
| 1.25 V ~ 1.00 V | 15.5kg/cm ² G (220psig) | 13.2kg/cm ² G (187.7psig) |
| 1.00 V ~ 0.75 V | 15kg/cm ² G (213psig) | 13.4kg/cm ² G (190.6psig) |
| 0.75 V ~ 0.50 V | 15kg/cm ² G (213psig) | 13.4kg/cm ² G (190.6psig) |
| 0.50 V ~ 0.25 V | 15kg/cm ² G (213psig) | 13.4kg/cm ² G (190.6psig) |
| 0.25 V ~ 0.00 V | 15kg/cm ² G (213psig) | 13.4kg/cm ² G (190.6psig) |

Installing a DOAS Interface Module

Setting the temperature

- ▶ Keep the power supply of Simple BMS in $10\text{ V} \pm 0.2\text{ V}$.
- ▶ If the Simple BMS uses variable resistor(VR), make the electric resistance of VR under $1\text{ k}\Omega$.
- ▶ Simple BMS which uses variable resistor(VR) need to be connected to the DOAS Interface Module with 1:1 link.
- ▶ Use the Simple BMS which outputs voltage so that one Simple BMS controls several DOAS Interface Module at the same time.

※ Allowed

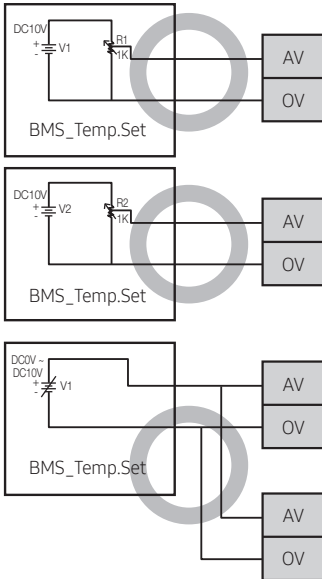

※ Not Allowed

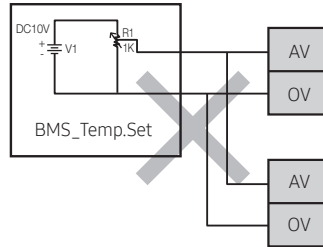

- Make sure that Simple BMS is connected to DC power supply before installing.
- Never connect Simple BMS to AC power supply.

Wiring diagram for Control assembly

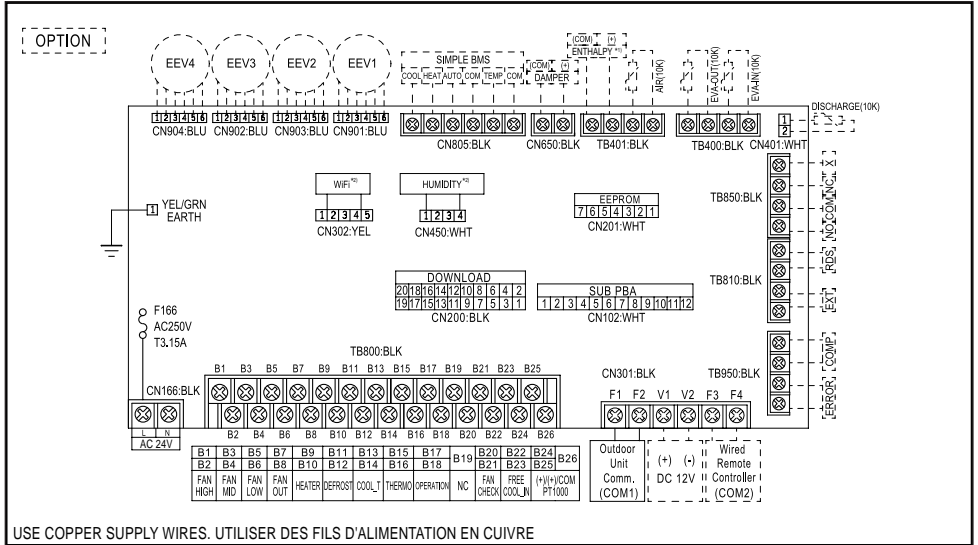

- ※ DOAS Interface Module sensor displays about 10 KΩ of resistance value at 70 °F (21.1 °C) room temperature.
- *1) Current-output sensor (Enthalpy or Temperature)
- *2) Wi-Fi and humidity are currently unused (reserved for future use)

Installing a DOAS Interface Module

Working on power supply

Connecting power/communication cable

- ▶ Turn the power off before working on the power supply.
- ▶ Maximum cable length and the amount of voltage drop for DOAS Interface Module power/communication cables should be within 10 %.
- ▶ Connect F3, F4 of DOAS Interface Module terminal to Wired Remote Control.
- ▶ Use the appropriate tools for wiring and make sure the wiring is connected tightly within the tightening torque to withstand the external pressure. Arrange the wires so that cover or other parts does not get loose. Otherwise, it may cause overheating, electric shock or fire.
- ▶ To protect the product from external shock or water, put the power and communication cable into a power cable protection box.
- ▶ Maintain more than 1.97”(50mm) distance between the power cable and communication cable.

| Tightening torque (lb•in) | |
|---------------------------|-------------|
| M4 | 10.42~12.76 |



CAUTION

- The circuit diagram for wiring represents only an outline so the detailed information about actual installation work is not described.
- In principle, DOAS Interface Module power supply should be provided separately from the outdoor unit.
- Do not distribute the communication cable as communication error may occur.
- Do not distribute the power cable of terminal block for 2 DOAS Interface Modules from 1 DOAS Interface Module.
- When peeling the sheath of power cable, use the appropriate tools to prevent damage inside the wire.
- Make sure that more than 1.97”(50mm) of power and communication cable of DOAS Interface Module is inside the electric parts.
- Communication cable should be installed separately from power cable or other communication cables.

Selecting a solderless terminal

1. Select a solderless terminal on the basis of nominal sectional area for a connecting power cable.
2. Insulate the solderless terminal and connection part of the connecting power cable with sheath.

| | | | | | |
|----|---|--|----------------------------------|----------------------------------|----------------------------------|
| | Nominal dimensions for cable [mm ² (inch ²)] | | 1.5 (0.002) | 2.5 (0.003) | 4 (0.006) |
| | Nominal dimensions for screw [mm(inch)] | | 4 (0.15") | 4 (0.15") | 4 (0.15") |
| B | Standard dimension [mm(inch)] | | 6.6 (0.25") | 8.0 (0.31") | 9.5 (0.37") |
| | Allowance [mm(inch)] | | ±0.2 (±0.007") | ±0.2 (±0.007") | ±0.2 (±0.007") |
| D | Standard dimension [mm(inch)] | | 3.4 (0.13") | 4.2 (0.16") | 5.6 (0.22") |
| | Allowance [mm(inch)] | | +0.3 (+0.011") -0.2 (-0.007") | +0.3 (+0.011") -0.2 (-0.007") | +0.3 (+0.011") -0.2 (-0.007") |
| d1 | Standard dimension [mm(inch)] | | 1.7 (0.06") | 2.3 (0.09") | 3.4 (0.13") |
| | Allowance [mm(inch)] | | ±0.2 (±0.007") | ±0.2 (±0.007") | ±0.2 (±0.007") |
| E | Min. [mm(inch)] | | 4.1 (3/16") | 6 (1/4") | 6 (1/4") |
| F | Min. [mm(inch)] | | 6 (1/4") | 6 (1/4") | 6 (1/4") |
| L | Max. [mm(inch)] | | 16 (5/8") | 17.5 (3/4") | 20 (3/4") |
| d2 | Standard dimension [mm(inch)] | | 4.3 (0.16") | 4.3 (0.16") | 4.3 (0.16") |
| | Allowance [mm(inch)] | | +0.2 (+0.007") 0 (0") | +0.2 (+0.007") 0 (0") | +0.2 (+0.007") 0 (0") |
| t | Min. [mm(inch)] | | 0.7 (0.02") | 0.8 (0.03") | 0.9 (0.035") |

Nitrogen flushing while brazing

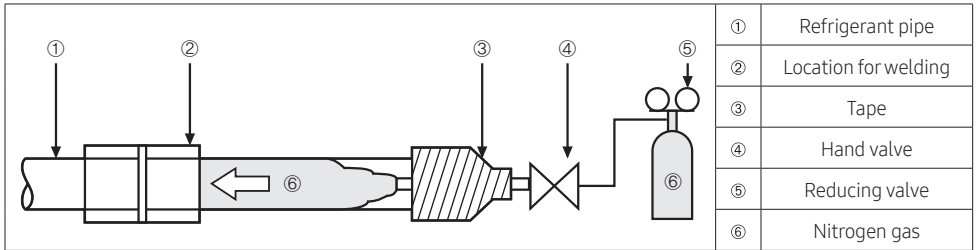

1. When welding a pipe, perform nitrogen blowing work.
 - If you didn't blow nitrogen through the refrigerant pipe during welding, many oxides will accumulate inside the pipe, which may cause the expansion valves and compressor to operate abnormally.
2. When inputting the nitrogen gas, the rate of flow for nitrogen gas should be less than 0.02 MPa (2.9 psi) using the reducing valve. (You should be able to feel the degree on your skin.)

Installing a DOAS Interface Module

Installing EEV Assembly (Not provided)

1. **Check that EEV Assembly is installed inside the indoor unit.**
 - Since dew condensation may occur around the EEV Assembly pipe, install the EEV Assembly at a place where condensate water can be drained.
2. **Check whether IN and OUT pipe connection is correct.**
3. **Essential to check the EEV Assembly main body is installed vertically.**
 - EEV Assembly main body should be installed within the range of $\pm 15^\circ$ of standard for vertical installation. Otherwise, the reliability of EEV Assembly cannot be guaranteed.
4. **Fix the EEV to indoor unit fixing groove firmly as shown in the image A below.**

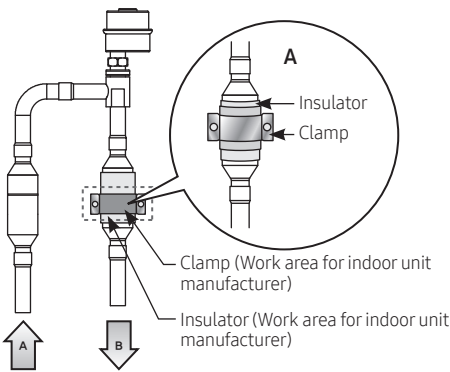

A: High pressure pipe from outdoor unit (IN)

B: Low pressure pipe to indoor unit heat exchanger (OUT)

| EEV | Diameter (A/B) |
|--------------------|------------------------------|
| V1EEVK05UC | $\Phi 15.88\text{mm}$ (5/8") |
| V1EEVK04UC | $\Phi 12.7\text{mm}$ (1/2") |
| V1EEVK(03/02/01)UC | $\Phi 9.52\text{mm}$ (3/8") |

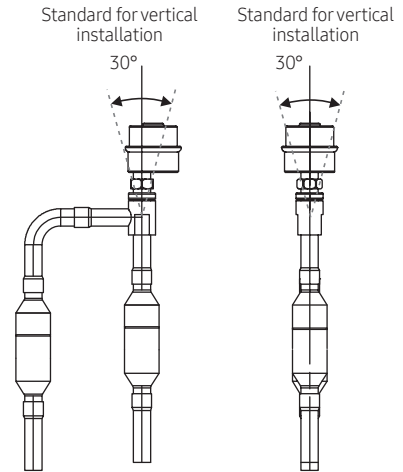

5. For checking EEV service, please attach a label sticker.

- ▶ Attach one label to upper middle part of EEV Assembly valve body and attach the same color of a label sticker to valve wire housing.

6. Connect the EEV terminal block to exact places on PCB according to set capacity.

- ▶ When there is 1 EEV: Connect EEV-1.
- ▶ When there are 2 EEV's: Connect EEV-1 and EEV-2.
- ▶ When there are 3 EEV's: Connect EEV-1, EEV-2, and EEV-3.
- ▶ When there are 4 EEV's: Connect EEV-1, EEV-2, EEV-3, and EEV-4.

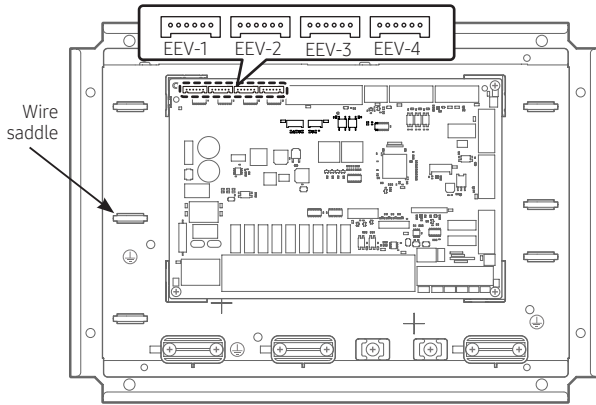

※ The EEV wire should be fixed using the wire saddle as shown in the image.



- Be careful when setting the number of the indoor unit installation with an outdoor unit.
- When setting DOAS Interface Module capacity, refer to the SEG 20 of Installation option 05 series on page 49.
- Regardless of the DOAS Interface Module capacity setting, one indoor unit will be recognized.

[EEV Models and Quantities for each Capacity (R-410A/R-32)]

▶ SEG 20 of the installation option 05 series

| Display | Rated Capacity (Btu/h) | Capacity Range (Btu/h) | Heat Exchanger Volume(in ³) | Assy EEV | Number of EEVs |
|---------|------------------------|------------------------|---|------------|----------------|
| 0 | 12k | 7k<capacity≤18k | 28<volume≤71 | V1EEVK01UC | 1 |
| 1 | 12k | 7k<capacity≤18k | 28<volume≤71 | V1EEVK01UC | 1 |
| 2 | 24k | 18k<capacity≤30k | 71<volume≤118 | V1EEVK02UC | 1 |
| 3 | 36k | 30k<capacity≤42k | 118<volume≤165 | V1EEVK03UC | 1 |
| 4 | 48k | 42k<capacity≤54k | 165<volume≤212 | V1EEVK03UC | 1 |
| 5 | 60k | 54k<capacity≤66k | 212<volume≤260 | V1EEVK04UC | 1 |
| 6 | 72k | 66k<capacity≤78k | 260<volume≤307 | V1EEVK04UC | 1 |
| 7 | 96k | 78k<capacity≤96k | 307<volume≤378 | V1EEVK04UC | 1 |
| 8 | 144k | 96k<capacity≤144k | 378<volume≤566 | V1EEVK05UC | 1 |
| 9 | 192k | 144k<capacity≤192k | 566<volume≤755 | V1EEVK05UC | 1 |
| A | 240k | 192k<capacity≤240k | 755<volume≤944 | V1EEVK05UC | 2 |
| B | 288k | 240k<capacity≤288k | 944<volume≤1133 | V1EEVK05UC | 2 |
| C | 336k | 288k<capacity≤336k | 1133<volume≤1322 | V1EEVK05UC | 2 |
| D | 384k | 336k<capacity≤384k | 1322<volume≤1510 | V1EEVK05UC | 2 |
| E | 576k | 384k<capacity≤576k | 1510<volume≤2266 | V1EEVK05UC | 3 |
| F | 768k | 576k<capacity≤768k | 2266<volume≤3021 | V1EEVK05UC | 4 |

Installing a DOAS Interface Module

Installing IN/OUT sensor

1. Attach the EVA IN sensor after the distributor and on the lowest temperature pipe of a heat exchanger.
 2. Install the EVA OUT sensor 7.87" (200 mm) after the header of Indoor unit heat exchanger as shown in the picture.
 3. Insulate the EVA IN and OUT sensor so that it is not affected by airflow.
 4. Install the ROOM temperature sensor in the RA (Return Air) path of indoor unit.
- ※ For DOAS (Dedicated Outside Air System) applications, install the ROOM temperature sensor and enthalpy sensor (optional) in the OA (Outdoor Air) path in front of the indoor unit heat exchanger.

Selecting the location of EVA_IN/OUT sensor

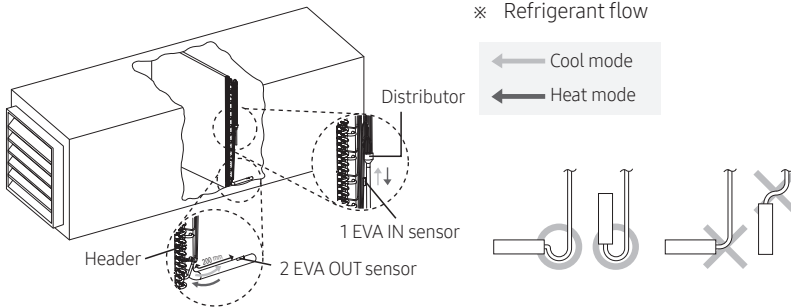

Example of ROOM temperature sensor installation

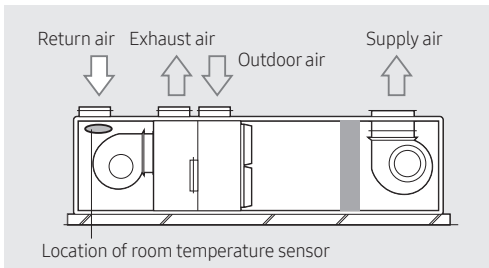

- In principle, the sensor holder of EVA IN/OUT sensor should be welded at the designated place and then the EVA IN/OUT sensor should be fixed with a clip.
- EVA IN/OUT sensor should be installed at the place where temperature of the heat exchanger inlet or outlet can be measured accurately.

Setting an indoor unit type

In the 02 series installation option SEG 24, configure the settings depending on the indoor unit.

| No. | Item | Type | Description | Control Item |
|-----|------------------|-------------------------------------|---|---|
| 1 | Indoor Unit Type | Common | Circulates indoor air in and out of indoor unit | Refer to the below table |
| | | Dedicated Outdoor Air System (DOAS) | Provides and conditions 100% outside air | |
| 2 | Fan Motor Type | Fixed | Cannot change the Fan speed. | H/M/L setting and display are not possible on the controller. |
| | | Variable | Can change the Fan speed to H, M, and L. | H/M/L setting and display are possible on the controller. |
| 3 | Enthalpy Sensor | Disuse | Does not use the enthalpy sensor. | |
| | | use | Uses the enthalpy sensor. | Even if the set temperature is satisfied in cooling mode, when the enthalpy sensor value is greater than the reference enthalpy setting value, the unit will still provide cooling. |

| No. | Control logic | Installation option 02 series SEG 24 | |
|-----|--|---|---|
| | | 'Common' setting | 'DOAS' setting |
| 1 | Preventing cold wind | Fan off when average evaporator temperature is below 82.4 °F (28 °C) in heating mode. | Fan off when average evaporator temperature is below 41 °F (5 °C) in heating mode. |
| 2 | Discharge air temperature control in HR mode | impossible | Possible (Main cooling only) While the outdoor unit is in main cooling mode, only units in heating mode can control discharge air temperature. Units in heating mode controls EEV step depending on target discharge temperature. |
| 3 | Thermo OFF decision | depending on room temperature only | depending on room temperature or discharge temperature |
| 4 | Operation restriction depending on outdoor temperature | use | disuse |

Fan Motor

In the installation option SEG 24, set the fan motor type.

1. In case of the fixed type setting

- ▶ Connect the PBA Fan out to the motor control signal.
- ▶ Contact closed = Fan On
Contact open = Fan Off

2. In case of the variable type setting

- ▶ Connect the PBA H/M/L to the motor control signal.
- ▶ Depending on the fan out (H/M/L), the corresponding contact output is closed.



- Do not power the motor with the fan speed output contacts. If the motor control is done with supply power (high voltage), an external relay must be installed (field provided).

Installing a DOAS Interface Module

Economizer (optional)

1. Function

1) Purpose

- Energy saving is possible by intaking 100% outdoor air during cooling operation when outdoor temperature is low.
→ This is free cooling operation : Thermo off occurs even though room temperature is higher than set temperature.

2) How it works

- It works by means of contact signal(input/output) between DOAS Interface Module PBA and economizer.
→ The PBA will use a 0-volt input contact signal and a 0-volt output contact signal.
- Installation option setting is not required for this function, but in case of DOAS setting, this function is not supported.



- When the contact for free cooling is closed, free cooling is enabled. When the contact is open, free cooling is not available.
- After checking the input/output specifications of the economizer, connect a suitable relay.

2. Control Logic

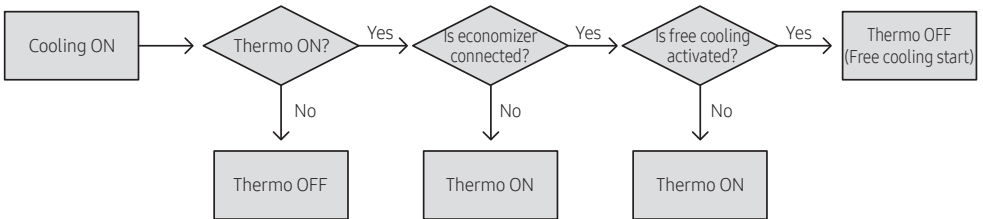

3. Wiring Connection

1) [B13/B14]

- Cooling thermo contact signal(output)
- Contact short : Cooling thermo on
- Contact open : Cooling thermo off or stop

2) [B22/B23]

- Free cooling contact signal(input)
- Contact short : Free cooling available
- Contact open : Mechanical cooling available

3) [Operation by Economizer controller]

- Cooling thermo on → Relay1 Close → Y1I Activate → Economizer decide mechanical cooling → Y1O Activate → Relay 2 Open(due to normally close relay) → Mechanical cooling start
- Cooling thermo on → Relay1 Close → Y1I Activate → Economizer decide free cooling → Y1O Deactivate → Relay 2 Close(due to normally close relay) → Free cooling start

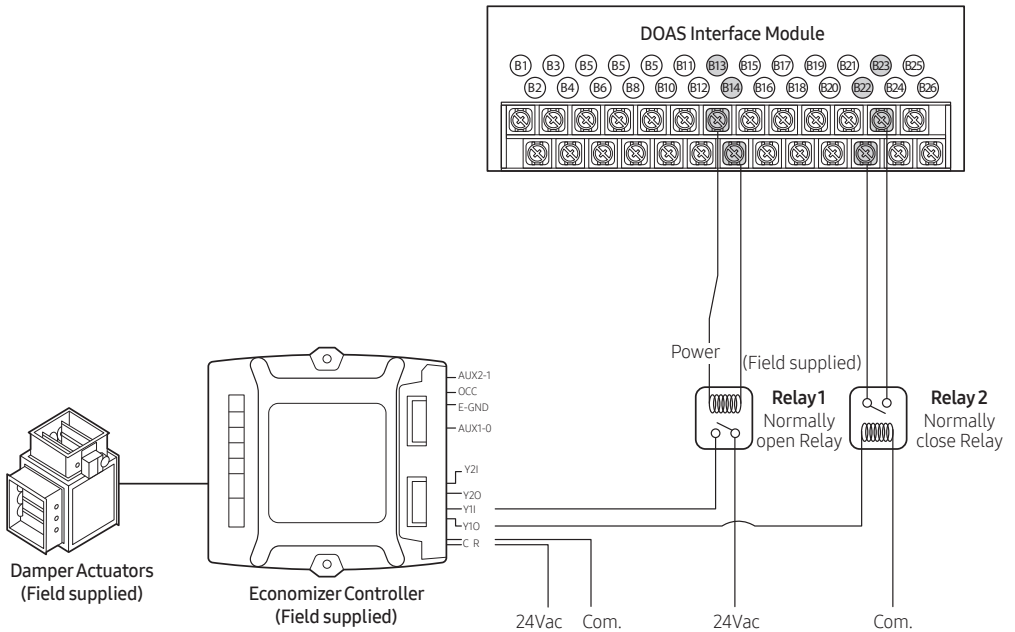

Installing a DOAS Interface Module

Damper (optional)

To control an outside air damper, the wiring between DOAS Interface Module PBA and ventilation damper and its installation option setting are required.

1. Installation Option Setup

| | Item | Description | Option Code | Default |
|--------|---|--|--------------------------------------|-----------------------------------|
| Step 1 | Use of the damper | Use or Disuse | 05 series installation option SEG 16 | Use |
| | Use of the damper in Fan mode | In Fan mode, whether or not to use the damper | | Use |
| | Use of variable control of the damper | Damper output fixed or variable | | Heating variable Cooling fixed |
| Step 2 | Minimum output setting for the damper | Range of 10 to 100% | 05 series installation option SEG 14 | 30% |
| Step 3 | Minimum temperature setting of the damper | Available when the temperature exceeds the setting | 05 series installation option SEG 15 | 32°F (0°C) |



• For more information, refer to the installation options.

2. Damper Output Control

1) Variable output control

- Depending on the room temperature and setting, the variable output (2 to 10 Vdc) is generated. As the temperature is closer to the setting, the damper output increases.
- Output (2 to 10 Vdc): 0 to 100%

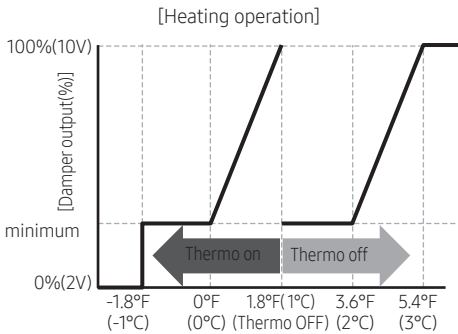

[Room temperature - Set temperature]

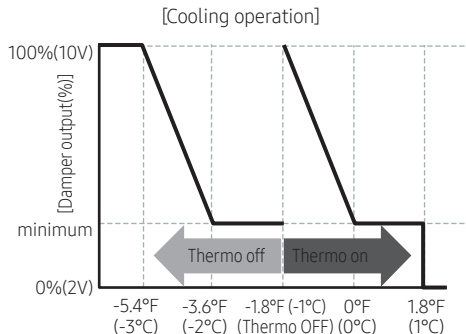

[Room temperature - Set temperature]

2) Fixed output control

- Regardless of the room temperature and setting, the fixed output is generated.
- Operation is available with the minimum output set as the installation option.

3) If free cooling is available by economizer controller, damper output is 100% (Contact input signal of the 'free cool in' on PBA is required)

3. Wiring Connection

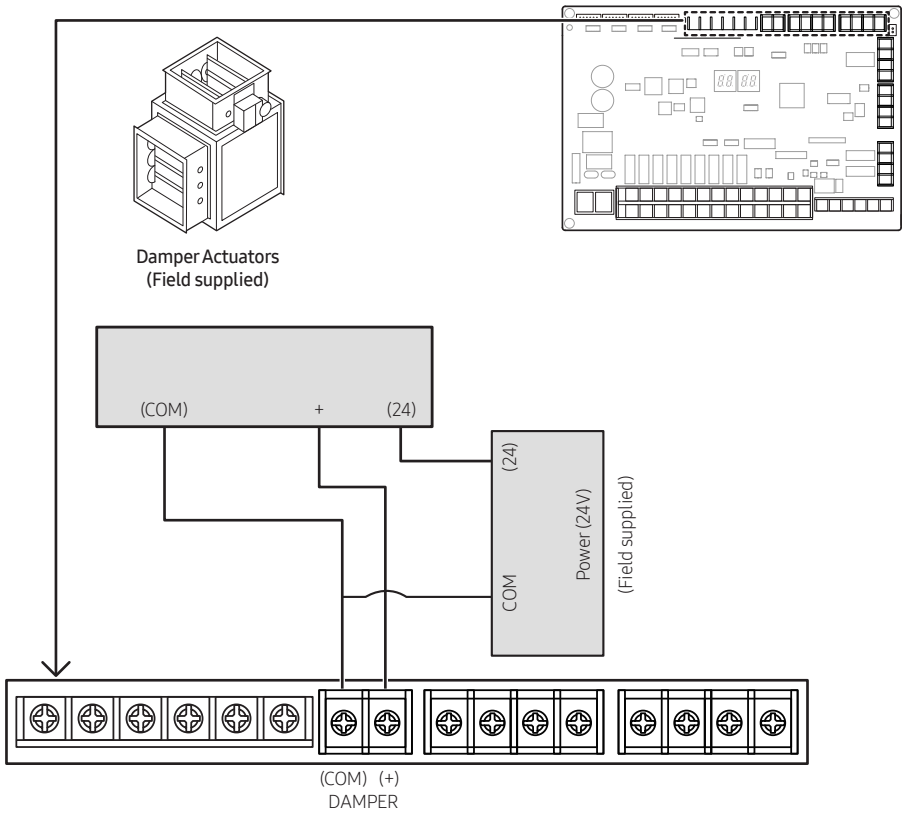

• Use the ventilation damper that satisfies the specification for the DOAS Interface Module PBA output (2 to 10 Vdc).

Current-output Sensor (optional)

In order to use an enthalpy sensor for cooling mode in a DOAS configuration, the wiring between DOAS Interface Module PBA and enthalpy sensor and its installation option setting are required.

1. Enthalpy sensor specification

- 1) Output current: 4 to 20 mA
- 2) Manufacturer/Model Name: Honeywell / C7400A



• Be sure to use the model name above.

2. Temperature Sensor specification

- 1) Output current: 4 to 20 mA
- 2) Temperature : -58°F(-50°C) ~ +122°F (50°C)

Installing a DOAS Interface Module

3. Enthalpy sensor control

- 1) The product operates in cooling mode based on the comparison between the intake enthalpy of the indoor unit and the reference enthalpy.
 - Reference enthalpy (installation option code; selectable according to the project requirements.)
 - Cooling Thermo OFF & (enthalpy > reference enthalpy): Cooling Thermo ON
- 2) The reference enthalpy for cooling Thermo ON can be set depending on the project conditions.
 - If it is required to keep a lower humidity, decrease the reference enthalpy. For a higher humidity, increase the reference enthalpy.
 - Set the reference enthalpy in the 05 series installation option SEG12 (reference enthalpy default: 50 kJ/kg (21.5 Btu/lb)).
- 3) Comparison of cooling operations depending on the enthalpy sensor availability

| Intake Temp. | Enthalpy Sensor Not Applicable | Enthalpy Sensor Applicable |
|--------------|--------------------------------|-------------------------------|
| B or above | ②: Thermo ON | ②: Thermo ON |
| Below B | ①: Thermo OFF ③: Thermo OFF | ①: Thermo OFF ③: Thermo ON |

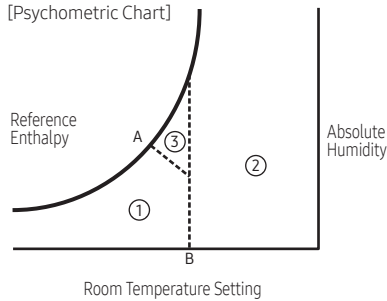

4. Wiring example

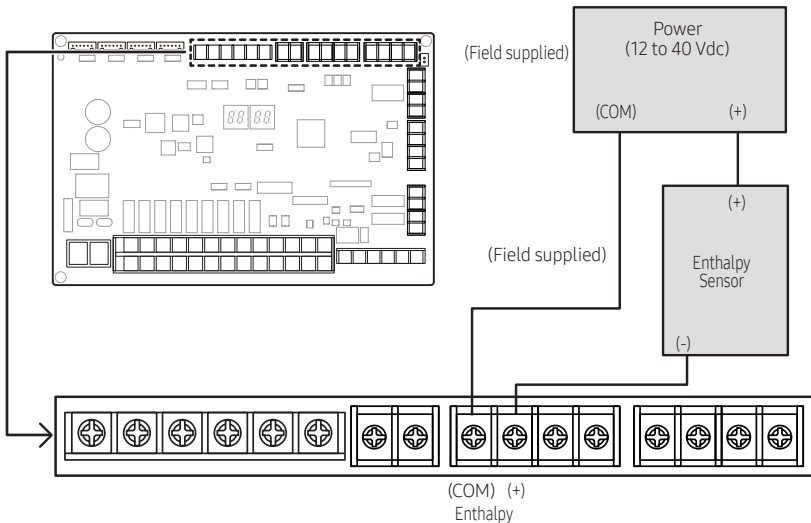

Setting the Temperature Sensor

Depending on the 05 series installation option SEG24, the temperature sensor type and temperature sensor main can be configured.

1. Setup of the room/discharge temperature sensor type
 - ▶ Room temperature sensor: Select the Supplied temperature sensor, PT1000, Current-output temperature sensor or Wired Remote Control.
 - ▶ Discharge temperature sensor: Select the Supplied temperature sensor and PT1000, Current-output temperature sensor.
 - ▶ PT1000, Current-output temperature sensor cannot use both room sensor and discharge temperature sensor (refer to SEG24 of 05 series installation option)
 - ▶ Upon use of PT1000, Current-output temperature sensor, the values and errors of Supplied temperature sensor are ignored and the values and errors of PT1000, Current-output temperature sensor are applied.
2. Setup of room and discharge temperature sensor main
 - ▶ No setting for the temperature sensor main: Temperature setting of the indoor unit is applied. (Main temperature sensor's value is not applied.)
 - ▶ Setting for the temperature sensor main: The value of the temperature sensor for the indoor unit is applied.
 - ▶ Temperature Sensor Main Value Sharing: The value of the temperature sensor for the indoor unit is not applied but the value of the temperature sensor main is applied.
3. Error handling
 - ▶ When two or more temperature sensor mains are set or the sub indoor unit does not receive information of the temperature sensor main for 2 minutes or setting for the temperature sensor main and temperature sensor main value sharing are configured simultaneously, E149 is generated.
4. Wiring example (setting a temperature sensor for installation of multiple DOAS Interface Modules)
 - ▶ In case of room temperature sensor PT1000

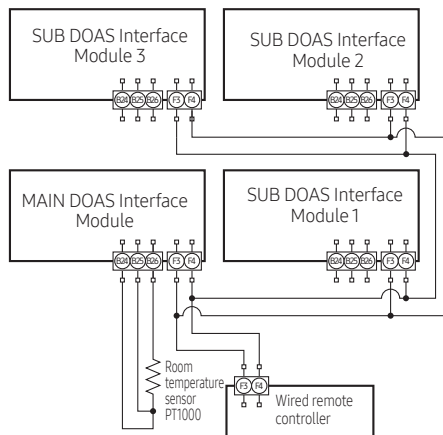

- For common AHU with multiple DOAS Interface Modules, sharing 1 room temperature sensor is possible. Room temperature sensor sharing uses the communication of wired remote controller, So a wired remote controller must be installed.

Installing a DOAS Interface Module

Requirements for R-32 system

To ensure safe operation of the system using R-32 refrigerant, verify that the requirements specified in the graphs and tables at the beginning of this manual are met.

RDS (optional)

If RDS installation is required, proceed with the installation.

1. RDS alarm in

- ▶ Type
 - Dry contact input
- ▶ Option
 - Normal closed(default) or Normal opened can be selected by Option.

2. wiring connection

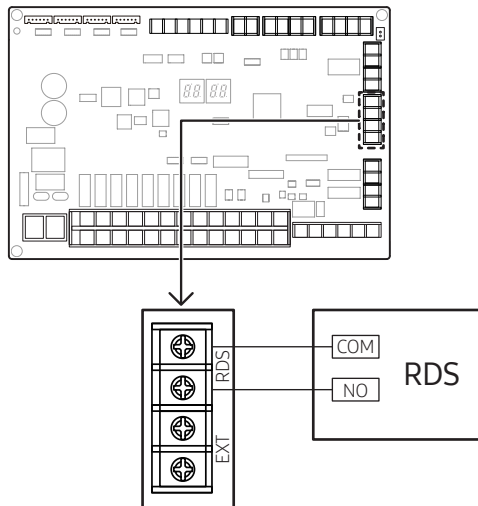

Example of IN/OUT sensor installation 1 - Brazing

1. Check the sensor and sensor holder you will attach.

| NOTE | Type | Diameter of a sensor (in(mm)) | Diameter of a sensor holder (in(mm)) |
|------|-------------------|-------------------------------|--------------------------------------|
| | IN sensor (Red) | Φ0.24" (Φ6) | Φ0.27" (Φ6.8) |
| | OUT sensor (Blue) | Φ0.28" (Φ7) | Φ0.31" (Φ7.8) |

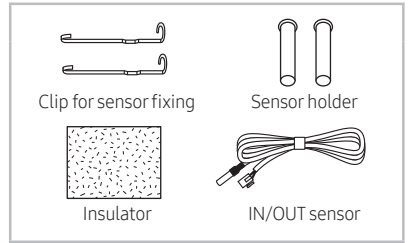

2. Brazing the sensor holder to the selected location of a pipe.

Brazing a sensor

- Brazing the sensor at the place where temperature detection is easily available. (Refer to p.24)
- Brazing the sensor holder as closely as possible on the surface of the pipe.
- Check whether the sensor you will attach is IN or OUT sensor. (The size of IN/OUT sensor is different.)
- The Brazing must be coated more than '2/3' of sensor holder length.

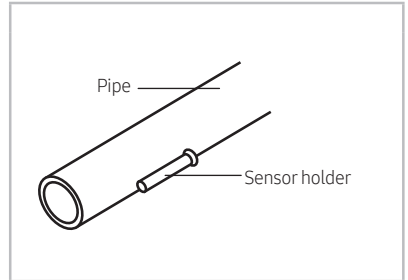

3. Insert the sensor and the clip into the sensor holder.

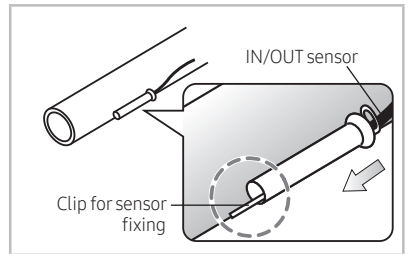

4. Bend the clip to fix it.

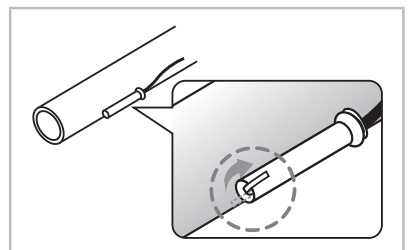

5. Attach the insulator around the attached sensor.

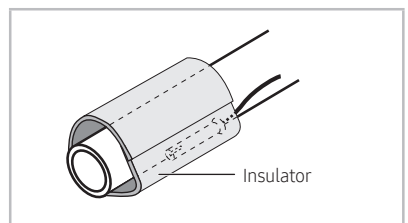

Installing a DOAS Interface Module

Example of IN/OUT sensor installation 2 - Tape

1. Check the sensor and sensor holder you will attach.

| NOTE | Type | Diameter of a sensor (in(mm)) | Diameter of a sensor holder (in(mm)) |
|------|-------------------|-------------------------------|--------------------------------------|
| | IN sensor (Red) | Φ0.24" (Φ6) | Φ0.27" (Φ6.8) |
| | OUT sensor (Blue) | Φ0.28" (Φ7) | Φ0.31" (Φ7.8) |

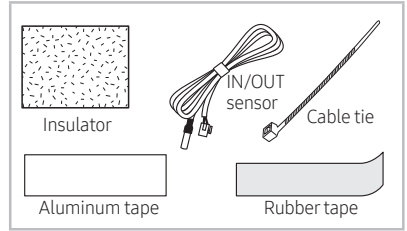

2. Attach the sensor closely to the pipe.

NOTE **Attaching a sensor**

- Attach the sensor at the place where temperature detection is easily available. (Refer to p.24)
- Attach the sensor as closely as possible on the surface of the pipe.
- Do not use a sensor holder.

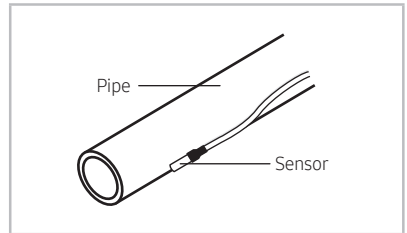

3. After attaching the sensor on the pipe, cover it with aluminum tape.

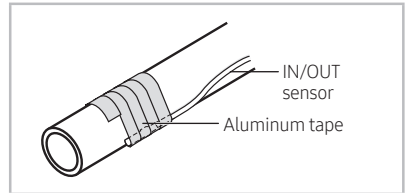

4. Cover the sensor with rubber tape.

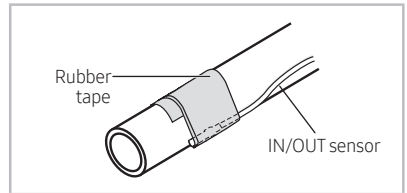

5. Fix the sensor with cable ties.

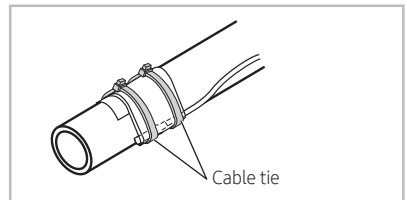

6. Attach the insulator around the attached sensor.

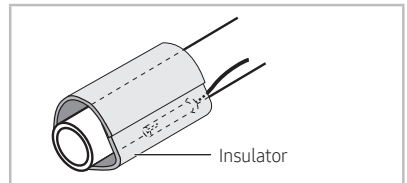

Setting the address and installation option of DOAS Interface Module

- ▶ Set the address and installation option with remote controller options. Set each option separately since you cannot set the ADDRESS setting and indoor unit installation setting option at the same time. You need to set twice when setting the address and installation option.
- ▶ The reception part of a remote controller is built.

Option Setting Procedure

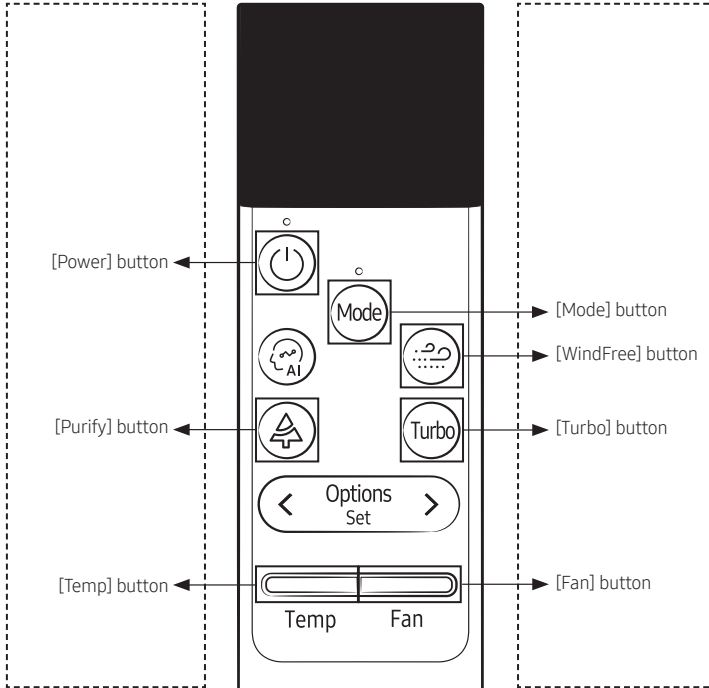

• The remote control display and buttons may vary depending on the model.

1. Enter the mode for setting the options.
 - 1) Reset remote control: button Down + button Down + Press for 10 seconds
 - 2) You can see "SW Initialization" message and enter the following in 5 seconds.
 - 3) Press button and button.
 - 4) Make sure that you are entered into the mode for setting options.



2 Digit

10 point (2SEG per point)
ex) now SEG2 and SEG3

Setting the address and installation option of DOAS Interface Module

2. Set the option values.





















































- The total number of available options is 24 : SEG1 to SEG24
- Because SEG1, SEG7, SEG13 and SEG19 are the page options used by the previous remote control models, the modes to set values for these options are skipped automatically.
- Set a 2-digit value for each option pair in the following order.
- You can see 20 SEG (except SEG1, SEG7, SEG13, SEG19) SEG2 → ... → SEG6 → SEG8 → → SEG12 → SEG14 → → SEG18 → SEG20 → ... → SEG24

| | | | | | | | | | | | |
|-------|-------|-------|-------|-------|-------|-------|-------|-------|-------|-------|-------|
| SEG1 | SEG2 | SEG3 | SEG4 | SEG5 | SEG6 | SEG7 | SEG8 | SEG9 | SEG10 | SEG11 | SEG12 |
| 0 | X | X | X | X | X | 1 | X | X | X | X | X |
| SEG13 | SEG14 | SEG15 | SEG16 | SEG17 | SEG18 | SEG19 | SEG20 | SEG21 | SEG22 | SEG23 | SEG24 |
| 2 | X | X | X | X | X | 3 | X | X | X | X | X |























- You can set the next SEG by pressing the button.
- You can change the digit value through the following operation.
Left value: up or down, range : 0 ~ F
Right value: up or down, range : 0 ~ F

Take the steps presented in the following table:

| Steps | Remote control display | |
|--|------------------------|--|
| 1. Set the SEG2 and SEG3 values: 1) Set the SEG2 value by pressing the button repeatedly until the value you want to set appears on the remote control display. 2) Set the SEG3 value by pressing the button repeatedly until the value you want to set appears on the remote control display. When you press the or button, values appear in the following order: 0 → 1 → ... → E → F | | |
| 2. Press the button to move to next page. | | |
| 3. Set the SEG4 and SEG5 values: 1) Set the SEG4 value by pressing the button repeatedly until the value you want to set appears on the remote control display. 2) Set the SEG5 value by pressing the button repeatedly until the value you want to set appears on the remote control display. When you press the or button, values appear in the following order: 0 → 1 → ... → E → F | | |
| 4. Press the button to move to next page. | | |
| 5. Set the SEG6 and SEG8 values: 1) Set the SEG6 value by pressing the button repeatedly until the value you want to set appears on the remote control display. 2) Set the SEG8 value by pressing the button repeatedly until the value you want to set appears on the remote control display. When you press the or button, values appear in the following order: 0 → 1 → ... → E → F | | |

| Steps | Remote control display |
|---|--|
| <p>6. Press the  button to move to next page.</p> |  |
| <p>7. Set the SEG9 and SEG10 values:</p> <p>1) Set the SEG9 value by pressing the  button repeatedly until the value you want to set appears on the remote control display.</p> <p>2) Set the SEG10 value by pressing the  button repeatedly until the value you want to set appears on the remote control display.</p> <p>When you press the  or  button, values appear in the following order:  →  → ...  → </p> |   SEG9 SEG10 |
| <p>8. Press the  button to move to next page.</p> |  |
| <p>9. Set the SEG11 and SEG12 values:</p> <p>1) Set the SEG11 value by pressing the  button repeatedly until the value you want to set appears on the remote control display.</p> <p>2) Set the SEG12 value by pressing the  button repeatedly until the value you want to set appears on the remote control display.</p> <p>When you press the  or  button, values appear in the following order:  →  → ...  → </p> |   SEG11 SEG12 |
| <p>10. Press the  button to move to next page.</p> |  |
| <p>11. Set the SEG14 and SEG15 values:</p> <p>1) Set the SEG14 value by pressing the  button repeatedly until the value you want to set appears on the remote control display.</p> <p>2) Set the SEG15 value by pressing the  button repeatedly until the value you want to set appears on the remote control display.</p> <p>When you press the  or  button, values appear in the following order:  →  → ...  → </p> |   SEG14 SEG15 |
| <p>12. Press the  button to move to next page.</p> |  |
| <p>13. Set the SEG16 and SEG17 values:</p> <p>1) Set the SEG16 value by pressing the  button repeatedly until the value you want to set appears on the remote control display.</p> <p>2) Set the SEG17 value by pressing the  button repeatedly until the value you want to set appears on the remote control display.</p> <p>When you press the  or  button, values appear in the following order:  →  → ...  → </p> |   SEG16 SEG17 |
| <p>14. Press the  button to move to next page.</p> |  |

Setting the address and installation option of DOAS Interface Module

| Steps | Remote control display | |
|--|--|---|
| <p>15. Set the SEG18 and SEG20 values:</p> <ol style="list-style-type: none"> 1) Set the SEG18 value by pressing the  button repeatedly until the value you want to set appears on the remote control display. 2) Set the SEG20 value by pressing the  button repeatedly until the value you want to set appears on the remote control display. <p>When you press the  or  button, values appear in the following order: 0 → 1 → ... E → F</p> |  SEG18 |  SEG20 |
| <p>16. Press the  button to move to next page.</p> |  00 | |
| <p>17. Set the SEG21 and SEG22 values:</p> <ol style="list-style-type: none"> 1) Set the SEG21 value by pressing the  button repeatedly until the value you want to set appears on the remote control display. 2) Set the SEG22 value by pressing the  button repeatedly until the value you want to set appears on the remote control display. <p>When you press the  or  button, values appear in the following order: 0 → 1 → ... E → F</p> |  SEG21 |  SEG22 |
| <p>18. Press the  button to move to next page.</p> |  00 | |
| <p>19. Set the SEG23 and SEG24 values:</p> <ol style="list-style-type: none"> 1) Set the SEG23 value by pressing the  button repeatedly until the value you want to set appears on the remote control display. 2) Set the SEG24 value by pressing the  button repeatedly until the value you want to set appears on the remote control display. <p>When you press the  or  button, values appear in the following order: 0 → 1 → ... E → F</p> |  SEG23 |  SEG24 |

3. Check whether the option values you have set are correct by pressing the  button repeatedly.



EX) 100000-200000-300000-400000

4. Save the option values into the indoor unit:

Point the remote control to the remote control sensor on the indoor unit and then press the  button on the remote control twice.



Make sure that this command is received by the indoor unit. When it is successfully received, you can hear a short sound from the indoor unit. If the command is not received, press the  button again.

5. Check whether the air conditioner operates following the option values you have set:



1) Reset the indoor or outdoor unit.

- Indoor Unit : Press  button +  button for 5 seconds

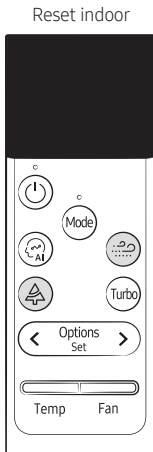

- Outdoor Unit: Press the K3 button

2) Reset remote control:  button Down +  button Down +  Press for 10 seconds You can see the "SW Initialization" message.

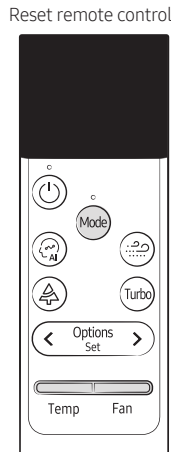

 press +  press



 Down +  Down +  Press for 10 seconds

Setting the address and installation option of DOAS Interface Module

Setting a DOAS Interface Module address (MAIN/RMC/MSB(SVB) port)

1. Check whether power is supplied or not.
 - When the DOAS Interface Module is not plugged in, there should be additional power supply.
2. The reception part of a remote controller is built in the DOAS Interface Module PBA.
3. Each address of DOAS Interface Module (MAIN/RMC) should be set according to installation conditions.
4. Assign each DOAS Interface Module address (MAIN/RMC) with a remote controller.
 - The initial setting status of DOAS Interface Module ADDRESS(MAIN/RMC/MSB(SVB) port) is "0A0000-100000-200000-300000"



• The MSB(SVB) and DOAS Interface Module addresses can be changed using Lennox Service Software. Add On > Change Address.

Option No. : 0AXXXX-1XXXXX-2XXXXX-3XXXXX

| Option | SEG1 | | SEG2 | | SEG3 | | SEG4 | | SEG5 | | SEG6 | |
|------------------------|------------|---------|------------|---------|----------------------|---------------------------|----------------------------------|-----------|-------------------------|----------|----------------------------------|--------------|
| Explanation | PAGE | | MODE | | Setting Main address | | 100-digit of indoor unit address | | 10-digit of indoor unit | | The unit digit of an indoor unit | |
| Indication and Details | Indication | Details | Indication | Details | Indication | Details | Indication | Details | Indication | Details | Indication | Details |
| | 0 | | A | | 0 | No Main address | | | | | | |
| | | | | | 1 | Main address setting mode | 0-9 | 100-digit | 0-9 | 10-digit | 0-9 | A unit digit |
| Option | SEG7 | | SEG8 | | SEG9 | | SEG10 | | SEG11 | | SEG12 | |
| Explanation | PAGE | | | | Setting RMC address | | | | Group channel | | Group address | |
| Indication and Details | Indication | Details | | | Indication | Details | | | Indication | Details | Indication | Details |
| | 1 | | | | 0 | No RMC address | | | | | | |
| | | | | | 1 | RMC address setting mode | | | RMC1 | 0-F | RMC2 | 0-F |

| Option | SEG13 | | SEG14 | | SEG15 | | SEG16 | | SEG17 | | SEG18 | | |
|------------------------|------------|---------|-------|--|-------------------------------|------------------------------------|------------------------------|----------|---------------------|---------|-----------------------|---------------|--|
| Explanation | PAGE | | | | Setting MSB(SVB) PORT address | | 10-digit of MSB(SVB) address | | 1-digit of MSB(SVB) | | MSB(SVB) PORT address | | |
| Indication and Details | Indication | Details | | | Indication | Details | Indication | Details | Indication | Details | Indication | Details | |
| | 2 | | | | 0 | No MSB(SVB) PORT | | | | | | | |
| | | | | | 1 | MSB(SVB) PORT address setting mode | 0-1 | 10-digit | 0-9 | 1-digit | A-F | PORT Location | |



- When "A"~"F" is entered to SEG5~6, the main address of DOAS Interface Module will not be changed.
- If you set the SEG 3 as 0, the DOAS Interface Module will maintain the existing MAIN ADDRESS even if you have entered the option value of SEG5~6.
- If you set the SEG 9 as 0, the DOAS Interface Module will maintain the existing RMC ADDRESS even if you have entered the option value of SEG11~12.
- If the indoor unit is connected to the MSB(SVB), you can set the SEG 15~18.
Example> If you want to set the DOAS Interface Module to 'A' port of MSB(SVB) #1. (0A0000 – 100000 – 20101A -30000)
- MSB(SVB) Port address settings initialization : Configure SEG15/16/17/18 as 1/0/0/0

Setting the installation option of a DOAS Interface Module (suitable for the condition of each installation location)

1. Check whether power is supplied or not.
 - When the DOAS Interface Module is not plugged in, there should be additional power supply.
2. A wireless controller signal receiver is built in the DOAS Interface Module PBA.
3. Set the installation option of a DOAS Interface Module according to installation conditions.
 - The default setting of a DOAS Interface Module installation option (02 series) is "020010-100000-200080-300000".
 - The default setting of a DOAS Interface Module installation option (05 series) is "050000-100003-224000-340000".
4. Set the DOAS Interface Module option with a remote controller, wired controller, Lennox Service Software.

02 series installation option

| SEG1 | SEG2 | SEG3 | SEG4 | SEG5 | SEG6 |
|-------|--|--|---|--|--|
| 0 | 2 | Evaporator Drying | External room temperature sensor/ Minimizing fan operation when thermostat is off | Central control | Dual Fuel (Heater Lock) temperature settings |
| SEG7 | SEG8 | SEG9 | SEG10 | SEG11 | SEG12 |
| 1 | Dual Fuel (HP Lock) temperature settings | Hot water coil/External heater | Contact signal | EEV Step when heating stops | (DOAS Interface Module) cold wind prevention skip setting |
| SEG13 | SEG14 | SEG15 | SEG16 | SEG17 | SEG18 |
| 2 | External control | Setting the output of external control / External heater signal / cooling operation signal | Additional load operation during heater control | Buzzer control / whether to use APP UX DSP (Dual Set Point) / whether to use R-32 sensor | Refrigerant leak detection sensor signal status setting |
| SEG19 | SEG20 | SEG21 | SEG22 | SEG23 | SEG24 |
| 3 | Forced air temperature setting (DOAS Function) | Compensation of heating setting | Oil return/EEV step of stopped defrost mode | Forced FAN Operation for Heating and Cooling | DOAS Interface Module model type/Enthalpy sensor/Fan motor type/ Airflow control |

Setting the address and installation option of DOAS Interface Module

- ▶ SEG5 central control option is basically set as 1 (Use), so you don't need to set the central control option additionally. When you exclude the indoor unit control from central control, change the setting as 0(Disuse).
- ▶ When you set the value other than the SEG setting values, it will be set as "0".
- ▶ The temperature settings based on °F/°C for SEG6 and SEG8 will be configured in the SEG16 of the O2 series installation option

Option No. : 02XXXX-1XXXXX-2XXXXX-3XXXXX

| Option | SEG1 | | SEG2 | | SEG3 ⁽¹⁾ | | SEG4 ⁽²⁾ | | | SEG5 | | SEG6 | | | | | | |
|---------------------------|------------|---------|------------|---------|---------------------|----------------|---|---|---|------------------------|---|---|---|---|--------|---|--|---|
| Explanation | PAGE | | MODE | | Evaporator Drying | | Use of external room temperature sensor/ Minimizing fan operation when thermostat is off | | | Use of central control | | Dual Fuel(Heater Lock) temperature settings based on °F/°C settings | | | | | | |
| Indication and Details | Indication | Details | Indication | Details | Indication | Details | Indication | Details | | Indication | Details | Indication | Details | | | | | |
| | | | | | | | | Use of External room temperature sensor | Minimizing fan operation when thermostat is off | | | | | 0 | Disuse | | | |
| Indication and Details | 0 | | 2 | | 0 | Disuse | 0 | Disuse | Disuse | 0 | Disuse | 1 | When set to °F, 65 °F (18.3 °C); when set to °C, 28 °C (82.4 °F) | | | | | |
| | | | | | | | 1 | Use | Disuse | | | 2 | When set to °F, 60 °F (15.6 °C); when set to °C, 15 °C (59 °F) | | | | | |
| | | | | | | | 2 | Disuse | Heating Use | | | 3 | When set to °F, 55 °F (12.8 °C); when set to °C, 9 °C (48.2 °F) | | | | | |
| | | | | | | | 3 | Use | Heating Use | | | 4 | When set to °F, 50 °F (10 °C); when set to °C, 6 °C (42.8 °F) | | | | | |
| | | | | | | | 4 | Disuse | Cooling Use | | | 5 | When set to °F, 45 °F (7.2 °C); when set to °C, 3 °C (37.4 °F) | | | | | |
| | | | | | | | 5 | Use | Cooling Use | | | 6 | When set to °F, 40 °F (4.4 °C); when set to °C, 0 °C (32 °F) | | | | | |
| | | | | | 4 | Use (10min) | 6 | Disuse | All Use | 1 | Use | 7 | When set to °F, 35 °F (1.7 °C); when set to °C, -3 °C (26.6 °F) | | | | | |
| | | | | | | | 7 | Use | All Use | | | 8 | When set to °F, 30 °F (-1.1 °C); when set to °C, -6 °C (21.2 °F) | | | | | |
| | | | | | | | 8 | Disuse | Use (Cooling Ultra Low Fan) | | | 9 | When set to °F, 25 °F (-3.9 °C); when set to °C, -9 °C (15.8 °F) | | | | | |
| | | | | | 6 | Use (30min) | 9 | Use | Use (Cooling Ultra Low Fan) | A | When set to °F, 20 °F (-6.7 °C); when set to °C, -12 °C (10.4 °F) | | | | | | | |
| | | | | | | | A | Disuse | Use (Heating / Cooling Ultra Low Fan) | B | When set to °F, 15 °F (-9.4 °C); when set to °C, -15 °C (5 °F) | | | | | | | |
| | | | | | | | B | Use | Use (Heating / Cooling Ultra Low Fan) | C | When set to °F, 10 °F (-12.2 °C); when set to °C, -18 °C (-0.4 °F) | | | | | | | |
| | | | | | | | | | | | | | | | | D | When set to °F, 5 °F (-15 °C); when set to °C, -21 °C (-5.8 °F) | |
| | | | | | | | | | | | | | | | | | E | When set to °F, 0 °F (-17.8 °C); when set to °C, -28 °C (-18.4 °F) |

| Option | SEG7 | | SEG8 | | SEG9 | | SEG10 | | | SEG11 | | SEG12 | | | | | | |
|---------------------------|------------|---------|--|---|---|---------|-------------------------------|---|---|--------------------------------|--------------------------------|--|---------|---------------|---|--------------------------------|---|--------------------------|
| Explanation | PAGE | | Dual Fuel(H/PLock) temperature settings based on °F/°C settings | | Use of hot water coil/ external heater ⁽²³⁾ | | Contact Signal ⁽⁴⁾ | | | EEV Step when heating stops | | (DOAS Interface Module) cold wind prevention skip setting | | | | | | |
| Indication and Details | Indication | Details | Indication | Details | Indication | Details | Indication | Details | | Indication | Details | Indication | Details | | | | | |
| | | | 0 | Disuse | | | | Thermal ON: Fan operation connection | Cooling thermal ON: Dehumidification including | | | | | | | | | |
| Indication and Details | 1 | | 1 | When set to °F, 45 °F (7.2 °C); when set to °C, 25 °C (77 °F) | 0 | Disuse | 0 | No | not including | 0 | Default value | 0 | Disuse | | | | | |
| | | | 2 | When set to °F, 40 °F (4.4 °C); when set to °C, 12 °C (53.6 °F) | | | | | | | | | | | | | | |
| | | | 3 | When set to °F, 35 °F (1.7 °C); when set to °C, 6 °C (42.8 °F) | | | | | | | | | | | | | | |
| | | | 4 | When set to °F, 30 °F (-1.1 °C); when set to °C, 3 °C (37.4 °F) | 1 | Use | 1 | Yes | not including | 1 | Noise decreasing setting | 1 | Use | | | | | |
| | | | 5 | When set to °F, 25 °F (-3.9 °C); when set to °C, 0 °C (32 °F) | | | | | | | | | | | | | | |
| | | | 6 | When set to °F, 20 °F (-6.7 °C); when set to °C, -3 °C (26.6 °F) | 2 | - | | | | | | 1 | Yes | not including | 1 | Noise decreasing setting | 1 | Use |
| | | | 7 | When set to °F, 15 °F (-9.4 °C); when set to °C, -6 °C (21.2 °F) | | | | | | | | | | | | | | |
| | | | 8 | When set to °F, 10 °F (-12.2 °C); when set to °C, -9 °C (15.8 °F) | | | | | | | | | | | | | | |
| | | | 9 | When set to °F, 5 °F (-15 °C); when set to °C, -12 °C (10.4 °F) | 3 | Use | | | | | | 2 | No | including | 1 | Noise decreasing setting | 1 | Use (Thermo Off Only) |
| | | | A | When set to °F, 0 °F (-17.8 °C); when set to °C, -15 °C (5 °F) | | | | | | | | | | | | | | |
| | | | B | When set to °F, -5 °F (-20.6 °C); when set to °C, -18 °C (-0.4 °F) | | | | | | | | | | | | | | |
| | | | C | When set to °F, -10 °F (-23 °C); when set to °C, -21 °C (-5.8 °F) | | | | | | | | | | | | | | |
| | | | D | When set to °F, -15 °F (-26 °C); when set to °C, -24 °C (-11.2 °F) | | | | | | | | | | | | | | |
| | | | E | When set to °F, -20 °F (-29 °C); when set to °C, -31 °C (-23.8 °F) | 4 | Use | | | | | | 3 | Yes | including | | | | |

Setting the address and installation option of DOAS Interface Module

| Option | SEG13 | | SEG14 | | SEG15 | | | SEG16 | | | | SEG17 | | | | SEG18 | | | | |
|------------------------|------------|---------|-------------------------|-----------------------|---|--|-------------------------------|---|-------------------|----------------------|--------------------------------------|--|----------------|------------|-------------|---|--------------|-----|--|--|
| Explanation | PAGE | | Use of external control | | Setting the output of external control / External heater signal / cooling operation signal ^(*) | | | Additional load operation during heater control | | | | Buzzer control / whether to use APP UX DSP (Dual Set Point) / whether to use R-32 sensor | | | | Refrigerant leak detection sensor signal status setting | | | | |
| Indication and Details | Indication | Details | Indication | Details | Indication | Details | | Indication | Details | | | Indication | Details | | | Indication | Details | | | |
| | | | | | | Setting the output of external control | External heater On/Off signal | | Defrosting Fan On | Defrosting Heater On | EH+HP Lock temperature table setting | | Buzzer Control | APP UX DSP | R-32 sensor | | | | | |
| Indication and Details | 2 | | 0 | Disuse | 0 | Thermo on | - | 0 | Disuse | Not applied | °F | 0 | Use Buzzer | Disuse | Disuse | 0 | Normal close | | | |
| | | | 1 | ON/OFF control | 1 | Operation on | - | 1 | Use | Not applied | °F | 1 | Disuse Buzzer | Disuse | Disuse | | | | | |
| | | | | | 2 | - | Use | 2 | Disuse | Applied | °F | 4 | Use Buzzer | Use | Disuse | | | | | |
| | | | 2 | OFF control | 3 | - | Use | 3 | Use | Applied | °F | 5 | Disuse Buzzer | Use | Disuse | 1 | Normal open | | | |
| | | | | | 4 | Cooling operation | | 8 | Disuse | Not applied | °C | 8 | Use Buzzer | Disuse | Use | | | | | |
| | | | 3 | Window ON/OFF control | 5 | | Use | 9 | Use | Not applied | °C | 9 | Disuse Buzzer | Disuse | Use | | | | | |
| | | | | | | | | A | Disuse | Applied | °C | C | Use Buzzer | Use | Use | | | | | |
| | | | | | | | | | | | B | Use | Applied | °C | D | Disuse Buzzer | Use | Use | | |

| Option | SEG19 | | SEG20 | | | SEG21 | | SEG22 | | SEG23 | | | SEG24 | | | | | | | | | | | |
|------------------------|------------|---------|---|---------------|---------------|---|------------|---|------------|--|------------|---------------------|---|-------------|-------------------------|--------------------------|----------------|------------------------------------|-------------------------|-------------|--------|--------|----------|-------------|
| Explanation | PAGE | | Forced air temperature setting (DOAS Function) ⁽¹⁾ | | | Offset of compensation for heating installation | | Oil return/EEV step of stopped defrost mode | | Forced FAN Operation for Heating and Cooling | | | DOAS Interface Module model type/Enthalpy sensor/Fan motor type/Airflow control | | | | | | | | | | | |
| | Indication | Details | Indication | Details | | | Indication | Details | Indication | Details | Indication | Details | | Indication | Details | | | | | | | | | |
| | | | | Cool | Heat | Heat (Max Heat-θ) | | | | | | Cooling Fan Setting | Heating Fan Setting | | Model type | Enthalpy sensor | Fan motor type | Allow airflow control in Auto mode | | | | | | |
| Indication and Details | 3 | | 0 | Disable | | | 0 | Default | 0 | Default value | 0 | Disuse | Disuse | 0 | Common | Disuse | Fixed | Not applied | | | | | | |
| | | | 1 | 50.0°F (10°C) | 71.6°F (22°C) | 71.6°F (22°C) | 1 | 3.6°F (2°C) | | | 0 | Default value | 1 | Disuse | Use (Fan: User setting) | 1 | DOAS | Disuse | Fixed | Not applied | | | | |
| | | | 2 | 51.8°F (11°C) | 50.0°F (10°C) | 46.4°F (8°C) | | | | | | | 2 | Disuse | Use (Fan: High) | 3 | DOAS | Use | Fixed | Not applied | | | | |
| | | | 3 | 53.6°F (12°C) | 50.0°F (10°C) | 50.0°F (10°C) | | | | | | | 3 | Disuse | Use (Fan: Low) | 4 | Common | Disuse | Variable | Not applied | | | | |
| | | | 4 | 55.4°F (13°C) | 53.6°F (12°C) | 53.6°F (12°C) | | | | | | | 2 | 9.0°F (5°C) | 1 | Noise decreasing setting | 4 | Use (Fan: User setting) | Disuse | 5 | DOAS | Disuse | Variable | Not applied |
| | | | 5 | 57.2°F (14°C) | 57.2°F (14°C) | 57.2°F (14°C) | | | | | | | | | | | 5 | Use (Fan: User setting) | Use (Fan: User setting) | 6 | Common | Use | Variable | Not applied |
| | | | 6 | 59.0°F (15°C) | 60.8°F (16°C) | 60.8°F (16°C) | | | | | | | | | | | 6 | Use (Fan: User setting) | Use (Fan: High) | 7 | DOAS | Use | Variable | Not applied |
| | | | 7 | 60.8°F (16°C) | 64.4°F (18°C) | 64.4°F (18°C) | | | | | | | | | | | 7 | Use (Fan: User setting) | Use (Fan: Low) | 8 | Common | Disuse | Fixed | Applied |
| | | | 8 | 62.6°F (17°C) | 66.2°F (19°C) | 66.2°F (19°C) | | | | | | | | | | | 8 | Use (Fan: High) | Disuse | 9 | DOAS | Disuse | Fixed | Applied |
| | | | 9 | 64.4°F (18°C) | 68.0°F (20°C) | 68.0°F (20°C) | | | | | | | | | | | 9 | Use (Fan: High) | Use (Fan: User setting) | A | Common | Use | Fixed | Applied |
| | | | A | 66.2°F (19°C) | 69.8°F (21°C) | 69.8°F (21°C) | | | | | | | | | | | A | Use (Fan: High) | Use (Fan: High) | B | DOAS | Use | Fixed | Applied |
| | | | B | 68.0°F (20°C) | 71.6°F (22°C) | 71.6°F (22°C) | | | | | | | | | | | B | Use (Fan: High) | Use (Fan: Low) | C | Common | Disuse | Variable | Applied |
| | | | C | 69.8°F (21°C) | 75.2°F (24°C) | 75.2°F (24°C) | | | | | | | | | | | C | Use (Fan: Low) | Disuse | D | DOAS | Disuse | Variable | Applied |
| | | | D | 71.6°F (22°C) | 78.8°F (26°C) | 78.8°F (26°C) | | | | | | | | | | | D | Use (Fan: Low) | Use (Fan: User setting) | E | Common | Use | Variable | Applied |
| | | | E | 73.4°F (23°C) | 82.4°F (28°C) | 82.4°F (28°C) | | | | | | | | | | | E | Use (Fan: Low) | Use (Fan: High) | F | DOAS | Use | Variable | Applied |
| | | | F | 75.2°F (24°C) | 86.0°F (30°C) | 86.0°F (30°C) | | | | | | | | | | | F | Use (Fan: Low) | Use (Fan: Low) | | | | | |

Setting the address and installation option of DOAS Interface Module

(*)⁽¹⁾ When Cool or Dry mode is off. The indoor fan operate in setting minutes.

(*)⁽²⁾ Minimizing fan operation when thermostat is off

- Fan operates for 20 seconds at an interval of 5 minutes in Heat mode.
- Fan stops when thermostat is off in Cool mode.
- Make sure to connect the wired remote controller or the external room temperature sensor if you use the function of external room temperature sensor or minimizing fan operation. (In order to implement the functions the option of using temperature sensor inside the wired remote controller must be set. Refer to the installation manual of the wired remote controller.

(*)⁽³⁾ 1: Fan is turned on continually when the hot water coil/external heater is turned on,

3: Fan is turned off when the hot water coil/external heater is turned on with cooling only indoor unit
Cooling only indoor unit: To use this option, install the Mode Select switch (MCM-C200) on the outdoor unit and fix it as Cool mode.

4: Fan speed is high mode continually when the hot water coil/external heater is turned on

(*)⁽⁴⁾ 1: Thermal ON contact signal(B17/B18) is related to fan operation : when the fan is stopped, the contact output for Thermo ON is not generated (e.g. defrosting operation).

2: Thermal ON contact signal(B17/B18) is not related to fan operation : Regardless of Fan ON/OFF, the contact output is generated with Thermo ON.

3: Cooling thermal ON contact(B13/B14) includes dehumidification thermal ON : The contact output is generated with cooling or dehumidification Thermo ON.

4: Cooling thermal ON contact(B13/B14) don't include dehumidification thermal ON : The contact output is generated with cooling Thermo ON

(*)⁽⁵⁾ When the following 2 or 3 is used as external heater On/Off signal, the signal for monitoring external contact control will not be output.

2: Fan is turned on continually when the external heater is turned on,

3: Fan is turned off when the external heater is turned on with cooling only indoor unit

Cooling only indoor unit: To use this option, install the Mode Select switch (MCM-C200) on the outdoor unit and fix it as Cool mode

4: The cooling operation status is displayed.

5: Fan speed stays in the high mode continuously when the hot water coil/external heater is turned on.

(*)⁽⁶⁾ When setting the DOAS and forced air temperature setting, the air(inlet) set temperature is fixed to the temperature specified in the option table and cannot be changed by other devices.

The discharge set temperature is set by default to 46.4°F (8°C) for cooling and 75.2°F (24°C) for heating, and can be changed by other devices.

This option applies to cooling and heating operation, and does not apply to auto operation.

Since the cooling and heating set temperatures cannot be assigned as separate options, do not enable this setting for devices that require cooling and heating mode chngerover.

■ 05 series installation option

| SEG1 | SEG2 | SEG3 | SEG4 | SEG5 | SEG6 |
|-------|--|---|---|---|---|
| 0 | 5 | Use of Auto Change Over for HR only in Auto mode / Whether to use SVB | (When setting SEG3) Standard heating temp. Offset | (When setting SEG3) Standard cooling temp. Offset | (When setting SEG3) Standard for mode change Heating → Cooling |
| SEG7 | SEG8 | SEG9 | SEG10 | SEG11 | SEG12 |
| 1 | (When setting SEG3) Standard for mode change Cooling → Heating | (When setting SEG3) Time required for mode change | Compensation option for Long pipe or height difference between indoor units | - | Criterion enthalpy |
| SEG13 | SEG14 | SEG15 | SEG16 | SEG17 | SEG18 |
| 2 | Damper minimum output | Damper opening minimum temperature | Damper control setting | Control Method by using simple BMS | Control variables when using hot water/ external heater ⁶⁾ |
| SEG19 | SEG20 | SEG21 | SEG22 | SEG23 | SEG24 |
| 3 | Capacity setting | Fan Feedback | Defrost signal | Main indoor unit sensor setting | Sensor |

■ 05 series installation option(Detailed)

Option No. : 05XXXX-1XXXXX-2XXXXX-3XXXXX

| Option | SEG1 | SEG2 | SEG3 | SEG4 | SEG5 | SEG6 | | | | |
|------------------------|------------|--|---|---|---|--|------------|-----------------|------------|-----------------|
| Explanation | PAGE | MODE | Use of Auto Change Over for HR only in Auto mode / Whether to use SVB | (When setting SEG3) Standard heating temp. Offset | (When setting SEG3) Standard cooling temp. Offset | (When setting SEG3) Standard for mode change Heating → Cooling | | | | |
| Indication and Details | Indication | Details | Indication | Details | Indication | Details | Indication | Details | Indication | Details |
| | | | | | | | | | | |
| | 1 | 0.9 °F (0.5 °C) | 1 | 0.9 °F (0.5 °C) | 1 | 2.7 °F (1.5 °C) | | | | |
| | 1 | Auto change over for HR only used | 3 | 1.8 °F (1 °C) | 2 | 1.8 °F (1 °C) | 2 | 3.6 °F (2 °C) | 3 | 4.5 °F (2.5 °C) |
| | | | | | | | | | | |
| | 3 | SVB not used for HP only (Consult qualified installer) | 5 | 4.5 °F (2.5 °C) | 5 | 4.5 °F (2.5 °C) | 5 | 6.3 °F (3.5 °C) | 6 | 7.2 °F (4 °C) |
| | | | | | | | | | | |
| | 7 | 6.3 °F (3.5 °C) | 7 | 6.3 °F (3.5 °C) | 7 | 6.3 °F (3.5 °C) | 7 | 8.1 °F (4.5 °C) | | |

Setting the address and installation option of DOAS Interface Module

| Option | SEG7 | SEG8 | | SEG9 | | SEG10 | | SEG11 | SEG12 | | | | | |
|------------------------|------------------|--|-----------------|--|----------------|---|---|-------------------------|------------------------------------|------------------------|--|------------|-------------------------------|--------------------------|
| Explanation | PAGE | (When setting SEG3) Standard for mode change Cooling → Heating mode | | (When setting SEG3) Time required for mode change | | Compensation option for Long pipe or height difference between indoor units | | - | Criterion enthalpy | | | | | |
| Indication and Details | Indication 1 | Indication | Details | Indication | Details | Indication | Details | Disuse | Indication | Details | | | | |
| | | 0 | 1.8 °F (1 °C) | 0 | 5 min. | 0 | Use default value | | 0 | 35 kJ/kg (15.0 Btu/lb) | | | | |
| | | 1 | 2.7 °F (1.5 °C) | 1 | 7 min. | 1 | 1) Height difference ¹⁾ is more than 98.4 ft (30 m) or 2) Distance ²⁾ is longer than 328.1ft (100 m) | | 1 | 40 kJ/kg (17.2 Btu/lb) | | | | |
| | | 2 | 3.6 °F (2 °C) | 2 | 9 min. | | | | 2 | 45 kJ/kg (19.3 Btu/lb) | | | | |
| | | 3 | 4.5 °F (2.5 °C) | 3 | 11 min. | | | | 3 | 50 kJ/kg (21.5 Btu/lb) | | | | |
| | | 4 | 5.4 °F (3 °C) | 4 | 13 min. | 2 | 1) Height difference ¹⁾ is 49.2 - 98.4 ft (5-30 m) or 2) Distance ²⁾ is 49.2 - 360.9 ft (15-110 m) | | 4 | 55 kJ/kg (23.6 Btu/lb) | | | | |
| | | 5 | 6.3 °F (3.5 °C) | 5 | 15 min. | | | | 5 | 60 kJ/kg (25.8 Btu/lb) | | | | |
| | | 6 | 7.2 °F (4 °C) | 6 | 20 min. | | | | | | | | | |
| 7 | 8.1 °F (4.5 °C) | 7 | 30 min. | | | | | | | | | | | |
| Option | SEG13 | SEG14 | | SEG15 | | SEG16 | | | SEG17 | | SEG18 | | | |
| Explanation | 2 | Damper minimum output | | Damper opening minimum temperature | | Damper control setting | | | Control Method by using simple BMS | | Control variables when using hot water/external heater ³⁾ | | | |
| | | Indication | Details | Indication | Details | Indication | Details | | Indication | Details | Indication | Details | | |
| | | | | | | | Damper operation (Fan mode) | Damper output (Cooling) | Damper output (Heating) | | | | Set temp. for heater On/Off | Delay time for heater On |
| | | 0 | 10% | 0 | 68 °F (20 °C) | 0 | Damper Disuse | | | 0 | Room Temperature | 0 | At the same time as thermo on | No delay |
| | | 1 | 20% | 1 | 59 °F (15 °C) | 1 | ON | Variable | Variable | | | 1 | At the same time as thermo on | 10 minutes |
| | | 2 | 30% | 2 | 50 °F (10 °C) | 2 | ON | Fixed | Variable | | | 2 | At the same time as thermo on | 20 minutes |
| | | 3 | 40% | 3 | 41 °F (5 °C) | 3 | ON | Variable | Fixed | 1 | Discharge Temperature | 3 | 2.7 °F (1.5 °C) | No delay |
| | | | | | | | | | | | | 4 | 2.7 °F (1.5 °C) | 10 minutes |
| | | | | | | | | | | | | 5 | 2.7 °F (1.5 °C) | 20 minutes |
| | | 6 | 5.4 °F (3.0 °C) | No delay | | | | | | | | | | |
| | | 7 | 5.4 °F (3.0 °C) | 10 minutes | | | | | | | | | | |
| | | 8 | 5.4 °F (3.0 °C) | 20 minutes | | | | | | | | | | |
| | | 4 | 50% | 4 | 32 °F (0 °C) | 4 | ON | Fixed | Fixed | 2 | Target Pressure (Cooling Mode : Evaporating Pressure Heating Mode : Condensing Pressure) | 7 | 8.1 °F (4.5 °C) | No delay |
| | | 5 | 60% | 5 | 23 °F (-5 °C) | 5 | OFF | Variable | Variable | | | 8 | 8.1 °F (4.5 °C) | 10 minutes |
| | | 6 | 70% | 6 | 14 °F (-10 °C) | 6 | OFF | Fixed | Variable | | | 9 | 10.8 °F (6.0 °C) | No delay |
| | | 7 | 80% | 7 | 5 °F (-15 °C) | 7 | OFF | Variable | Fixed | F | Only Operation Mode Control (Temperature/ Pressure Control Not applied) | A | 10.8 °F (6.0 °C) | 10 minutes |
| B | 10.8 °F (6.0 °C) | | | | | | | | | | | 20 minutes | | |
| C | 10.8 °F (6.0 °C) | | | | | | | | | | | No delay | | |
| 8 | 90% | 8 | -4 °F (-20 °C) | 8 | OFF | Fixed | Fixed | D | 10.8 °F (6.0 °C) | | | 10 minutes | | |
| 9 | 100% | | | | | | | E | 10.8 °F (6.0 °C) | | | 20 minutes | | |

| Option | SEG19 | SEG20 | | SEG21 | | SEG22 | | SEG23 | | SEG24 | | | | |
|------------------------|--------------------|--------------------------------|---------|----------------------------|------------------|---------------------------------|---------|---------------------------------|-----------------------------------|--|------------------|---|------------|-------------------|
| Explanation | PAGE | Capacity setting ⁴⁾ | | Fan Feedback | | Defrost signal ⁵⁾ | | Main indoor unit sensor setting | | Sensor ⁶⁾ | | | | |
| Indication and Details | Indication Details | Indication | Details | Indication | Details | Indication | Details | Indication | Details | Details | | | | |
| | | 3 | 0 | | | 12k Btu/h | 0 | Disuse | 0 | Disuse | 0 | Main indoor unit sensor not set | Indication | Room temp. sensor |
| 1 | 12k Btu/h | | 0 | Supplied (103AT) | Supplied (103AT) | | | | | | | | | |
| 2 | 24k Btu/h | | 1 | Supplied (103AT) | PT1000 | | | | | | | | | |
| 3 | 36k Btu/h | | 1 | Defrost Bypass valve using | 2 | Supplied (103AT) | | | Current output temperature sensor | | | | | |
| 4 | 48k Btu/h | | | | 3 | Wired remote controller | | | Supplied (103AT) | | | | | |
| 5 | 60k Btu/h | | | | 4 | Wired remote controller | | | PT1000 | | | | | |
| 6 | 72k Btu/h | | 2 | Defrost signal | 5 | Wired remote controller | | | Current output temperature sensor | | | | | |
| 7 | 96k Btu/h | | | | 6 | PT1000 | | | Supplied (103AT) | | | | | |
| 8 | 144k Btu/h | | | | 7 | PT1000 | | | Current output temperature sensor | | | | | |
| 9 | 192k Btu/h | | 1 | Use | 3 | Oil recovery signal | 1 | Main indoor unit sensor set | 8 | Current output temperature sensor | Supplied (103AT) | | | |
| A | 240k Btu/h | | | | | | | | 4 | Defrost Bypass valve using and Oil recovery signal | 9 | Current output temperature sensor | PT1000 | |
| B | 288k Btu/h | | | | | | | | | | A | Sharing temp (room, discharge), value of a main indoor unit | | |
| C | 336k Btu/h | | | | 5 | Defrost and Oil recovery signal | | | | | B | Sharing temp (room, discharge,EVA IN/ OUT), value of a main indoor unit | | |
| D | 384k Btu/h | | | | | | | | | | | | | |
| E | 576 Btu/h | | | | | | | | | | | | | |
| F | 768 Btu/h | | | | | | | | | | | | | |

¹⁾ Height difference : The difference of the height between the corresponding indoor unit and the indoor unit installed at the lowest place.

For example, When the indoor unit is installed 131.23 ft (40 m) higher than the indoor unit installed at the lowest place, select the option "1".

²⁾ Distance : The difference between the pipe length of the indoor unit installed at the farthest place from an outdoor unit and the pipe length of the corresponding indoor unit from an outdoor unit. For example, when the farthest pipe length is 328 ft (100 m) and the corresponding indoor unit is 131.23 ft (40 m) away from an outdoor unit, select the option "2". (328 ft (100 m) - 131.23 ft (40 m) = 196.85 ft (60 m))

³⁾ Heater operation when the SEG9 of O2 series installation option is set to using hot water coil/external heater or when SEG15 is set to using external heater.

Example 1) Setting O2 series SEG9 = "1" / Setting O5 series SEG18 = "0": The hot water coil/external heater is turned on at the same time as the heating thermostat is on, and turned off when the heating thermostat is off.

Example 2) Setting O2 series SEG15 = "2" / Setting O5 series SEG18 = "A": Room temp. ≤ set temp. + f (heating compensation temp.)

- External heater is turned on when the temperature is maintained as 8.1 °F (4.5 °C) for 10 minutes. Room temp. > set temp. + f(heating compensation temp.)

- External heater is turned off when the temperature is maintained as 8.1 °F (4.5 °C)+ 1.8 °F (1 °C) (1.8 °F (1 °C) is the Hysteresis for On/Off selection.)

⁴⁾ Default setting is 48k Btu/h

⁵⁾ Set the fan operation during defrost using O2 series installation option SEG16.

Setting the address and installation option of DOAS Interface Module

6) For use of PT1000, pay attention to the setup options and sensor connection. (In case of a setup error, normal operation is not possible.)

The enthalpy sensor (configured in the O2 series installation option SEG24) and the Current output temperature sensor cannot be used simultaneously.

In the wired remote control mode, extra setting for the temperature sensor is required.

In case of using wired remote controller sensor, room temperature sensor does not have to be connected to PBA.

Additional information for SEG 3,4,5,6,8,9

When the SEG 3 is set as "1" and follow Auto Change Over for HR only operation, it will operate as follows.

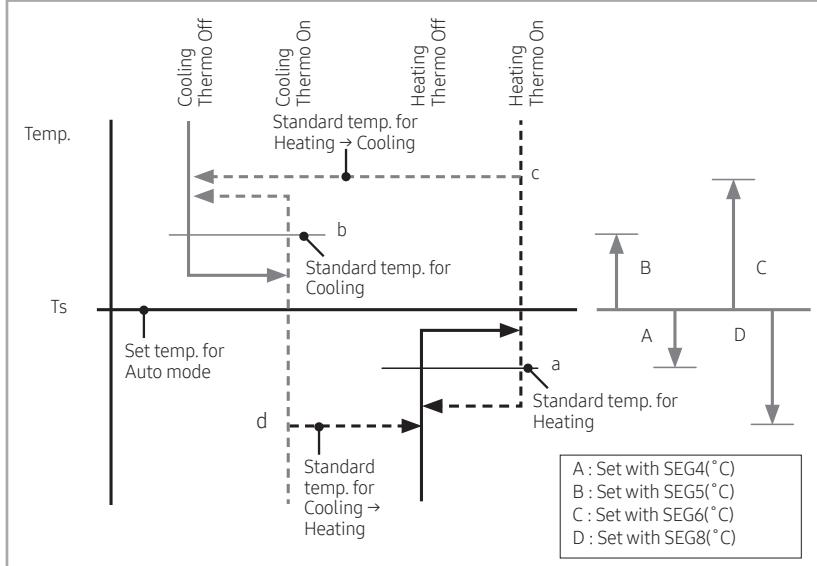

Cooling/Heating mode can be changed when Thermo Off status is maintained during the time with SEG9.

Changing a particular option

You can change each digit of set option.

| Option | SEG1 | | SEG2 | | SEG3 | | SEG4 | | SEG5 | | SEG6 | |
|------------------------|------------|---------|------------|---------|-----------------------|---------|--|---------|---------------------------------------|---------|---------------|---------|
| Explanation | PAGE | | MODE | | Option mode to change | | Tens' digit of an option SEG to change | | Unit digit of an option SEG to change | | Changed value | |
| Indication and Details | Indication | Details | Indication | Details | Indication | Details | Indication | Details | Indication | Details | Indication | Details |
| | 0 | | D | | Option mode | 0~F | Tens' digit of SEG | 0~9 | Unit digit of SEG | 0~9 | Changed value | 0~9 |



- When changing a digit of a DOAS Interface Module address setting option, set the SEG3 as 'A'.
- When changing a digit of a DOAS Interface Module installation option, set the SEG3 as '2'.

Ex) When setting the 'buzzer control' into disuse status.

| Option | SEG1 | SEG2 | SEG3 | SEG4 | SEG5 | SEG6 |
|-------------|------|------|-----------------------|--|---------------------------------------|---------------|
| Explanation | PAGE | MODE | Option mode to change | Tens' digit of an option SEG to change | Unit digit of an option SEG to change | Changed value |
| Indication | 0 | D | 2 | 1 | 7 | 1 |

Setting discharge temperature control

1. In service mode of a wired remote control, you can set whether to use "Discharge temperature control" or not and also can set targeted temperature of heating and cooling. Refer to "Installation/service setting mode" in a wired remote controller's installation manual.
2. If you set to use "Discharge temperature control", the thermal status of the unit is turned ON/OFF according to room set temperature and room temperature. Discharge temperature control is carried out while thermal-ON.
 - ※ The discharge temperature control can be set using DMS, also.
 - ※ Discharge temperature may not meet the desired temperature(set value) depending on conditions of the external air.
3. When the discharge temperature control is used, SEG21 of 01 series Product option must be set as "1".
 Disuse of discharge temperature control : 010053-105000-202323-330000
 Use of discharge temperature control : 010053-105000-202323-331000

Trouble shooting

Key function

| K1 (Number of press) | Key operation | Display on segment | |
|----------------------|---|-----------------------------|---|
| | | SEG1 | SEG 2, 3, 4 |
| 1 time | Indoor unit capacity | 1 | 20kW → 020 |
| 2 times | Operation mode | 2 | (Auto) Cooling → C, C, C (Auto) Heating → H, H, H Dehumidification → D, D, D Fan mode → F, F, F Operation OFF → O, F, F |
| 3 times | Room setting temperature | 3 | 27°C → 027 / 81°F → 081 |
| 4 times | Room temperature | 4 | -42°C → -42 / -44°F → -44 |
| 5 times | Discharge air setting temperature (cooling) | 5 | 27°C → 027 / 81°F → 081 |
| 6 times | Discharge air setting temperature (heating) | 6 | 27°C → 027 / 81°F → 081 |
| 7 times | Discharge air temperature | 7 | 27°C → 027 / 81°F → 081 |
| 8 times | EVA in temperature | 8 | -42°C → -42 / -44°F → -44 |
| 9 times | EVA out temperature | 9 | -42°C → -42 / -44°F → -44 |
| 10 times | EEV step | A | 1400 → 140 |
| 11 times | Fan output | B | On → 00, Off → 001 |
| 12 times | Defrost Valve output | C | On → 00, Off → 001 |
| 13 times | Free cooling contact signal | D | On → 00, Off → 001 |
| 14 times | Damper output | E | 50% → 050 |
| 15 times | Enthalpy value | F | 50.5 → 505 |
| 16 times | Enthalpy control entry | H | On → 00, Off → 001 |
| 17 times | Main address | I | 63 → 063 |
| 18 times | RMS address | J | FE → 0FE |
| 19 times | Version | Version (2026/10/26) → 6A29 | |

- ※ K2(press 1 time) : Indoor unit Reset
- ※ Default display is room temperature when initial power is on.
- ※ The temperature is displayed in Celsius or Fahrenheit according to the product option.

Initial check-up

1. **Check the connection status between an outdoor unit and the DOAS Interface Module.**
 - ▶ Check that you have followed wiring method according to the circuit diagram or installation manual.
 - ▶ Check that DOAS Interface Module PBA is installed in a place where there is no influence from outdoor humidity, dust and temperature.
2. **Check the power voltage is 24VAC.**
3. **Check the voltage of each part has a problem.**
 - ▶ 5 V-GND both terminals: DC 4.5~5.5 V
 - ▶ 12 V-GND both terminals: DC 11~13 V

Error on EEPROM

| | |
|----------------------|--|
| Outdoor unit display | <i>E162</i> |
| Description | Communication problem between EEPROM of DOAS Interface Module and micom. |
| Reason | - EEPROM PBA OF DOAS Interface Module ERROR(Physical problem of parts/circuit) - Replace EEPROM PBA |



- Wired remote controller will display the same error shown in the outdoor unit.

Error on the option of a remote controller

| | |
|----------------------|--|
| Outdoor unit display | <i>E163</i> |
| Description | The remote controller option of DOAS Interface Module is not the same. |
| Reason | Enter the remote controller option again. |

Trouble shooting

Error on a sensor

Error on the detachment of DOAS Interface Module heat exchanger EVA IN sensor

| | |
|----------------------|---|
| Outdoor unit display | E128 ← A^{xxx} (xxx: Address of an indoor unit with an error) |
| Description | Refer to the description below. |
| Reason | Detachment of indoor heat exchanger EVA IN piping sensor |

1. Description

- In Cool mode

| | |
|---|---|
| Tcond, out-Tair, out > 5.4 °F (3 °C) | OK |
| Tair, in-TEVA, in > 7.2 °F (4 °C) | NO |
| Tair, in-TEVA, out > 7.2 °F (4 °C) | NO |
| Indoor unit operation or thermo ON during operation of a compressor | OK |
| Error message | Error on the detachment of indoor unit heat exchanger EVA IN sensor |

2. Checking method

- After checking the detachment status of DOAS Interface Module heat exchanger EVA IN sensor, assemble the sensor.

Error on the detachment of DOAS Interface Module heat exchanger EVA OUT sensor

| | |
|----------------------|---|
| Outdoor unit display | E129 ← A^{xxx} (xxx: Address of an indoor unit with an error) |
| Description | Refer to the description below. |
| Reason | Detachment of indoor heat exchanger EVA OUT piping sensor |

1. Description

- In Cool mode

| | |
|---|--|
| Tcond, out-Tair, out > 5.4 °F (3 °C) | OK |
| Tair, in-TEVA, in > 7.2 °F (4 °C) | OK |
| Tair, in-TEVA, out > 7.2 °F (4 °C) | NO |
| Indoor unit operation or thermo ON during operation of a compressor | OK |
| Error message | Error on detachment of indoor unit heat exchanger EVA OUT sensor |

2. Checking method

- After checking the detachment status of DOAS Interface Module heat exchanger EVA OUT sensor, assemble the sensor.



- Wired remote controller will display the same error shown in the outdoor unit.

Error on DOAS Interface Module temperature sensor OPEN/SHORT

1. Checking method

| | |
|----------------------|---|
| Outdoor unit display | E121 (Room temperature sensor OPEN/SHORT) E126 (Discharge temperature sensor OPEN/SHORT) |
| Description | When the temperature sensor part of DOAS Interface Module is detected as OPEN/SHORT |
| Reason | Incorrect installation of PT1000 temperature sensor or supplied temperature sensor |

Temperature feature table of PT1000

- ▶ After detaching the connector(CN41), measure the electric resistance between terminal A and terminal C, and between terminal B and terminal C and then compare the table below. If the resistance is out of -22 °F (-30 °C) ~ 122 °F (+50 °C) section, it will be displayed as error indication area.

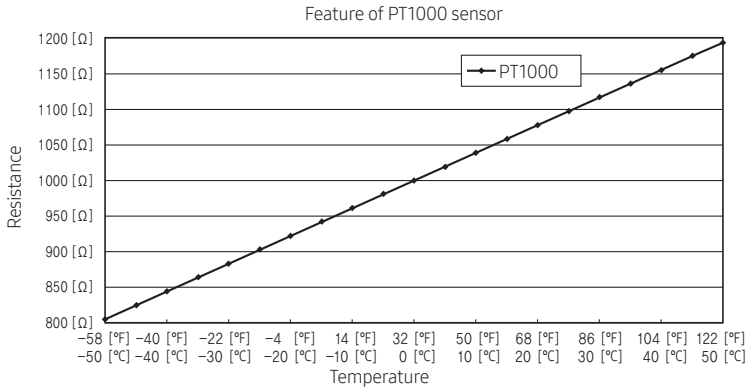

Feature table of supplied temperature sensor

- ▶ Check the resistance value of room temperature sensor connector and the PBA after disconnecting them.

| Temperature °F (°C) | Resistance value (kΩ) |
|---------------------|-----------------------|
| 158 (70) | 2.2 |
| 140 (60) | 3.0 |
| 122 (50) | 4.2 |
| 104 (40) | 5.8 |
| 86 (30) | 8.3 |
| 68 (20) | 12.1 |
| 50 (10) | 18.0 |
| 32 (0) | 27.3 |
| 14 (-10) | 43.0 |

Trouble shooting

Feature table of Current output temperature sensor

- ▶ After measuring the DC voltage of mA+/- terminal in connector(CN41) connection status, compare the voltage with the table below. If the voltage is out of -58°F (-50°C) ~ 122°F (+50°C) section, it will be displayed as error indication area.
- ▶ The range of Current output temperature sensor (4~20mA) : -58°F (-50°C) ~ 122°F (+50°C)

Feature of Current output temperature sensor

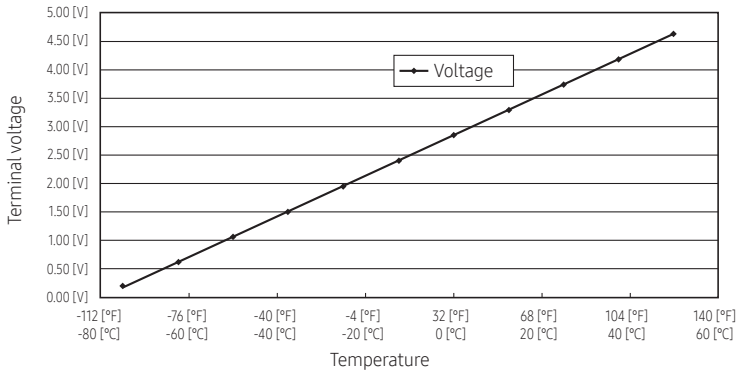

- Wired remote controller will display the same error shown in the outdoor unit.

Error on DOAS Interface Module enthalpy sensor OPEN/SHORT

| | |
|----------------------|--|
| Outdoor unit display | E189 enthalpy sensor OPEN/SHORT or simultaneous configuration of enthalpy and mA sensor settings |
| Description | When the enthalpy sensor of the DOAS Interface Module is OPEN or SHORT (The enthalpy value is below 2 mA for 2 minutes.) When simultaneous configuration of enthalpy and mA sensor settings |
| Reason | Loose contact between the sensor and PBA Installation options are incorrectly configured |

1. Checking method

- ▶ Check for the enthalpy value in DOAS Interface Module view mode.
- ▶ Under 2 mA or below, check the following items:
 - Incorrect installation of enthalpy sensor
 - Defective sensor
 - Wrong setting of the O2 series installation option SEG 24
- ▶ Check the installation options. The following options cannot be configured simultaneously.
 - Enthalpy sensor use : O2 series Installation option SEG24 = 2 or 3 or 6 or 7 or A or B or E or F
 - mA sensor use : O5 series Installation option SEG24 = 2 or 5 or 7 or 8 or 9

Error on DOAS Interface Module refrigerant leak detection sensor

| | |
|----------------------|--|
| Outdoor unit display | E697 (Refrigerant leak detection error) |
| Description | When the refrigerant leak detection sensor signal is turned on |
| Reason | Refrigerant leak detection or Short/Open or Normal Open/Close misconfiguration |

1. Checking method

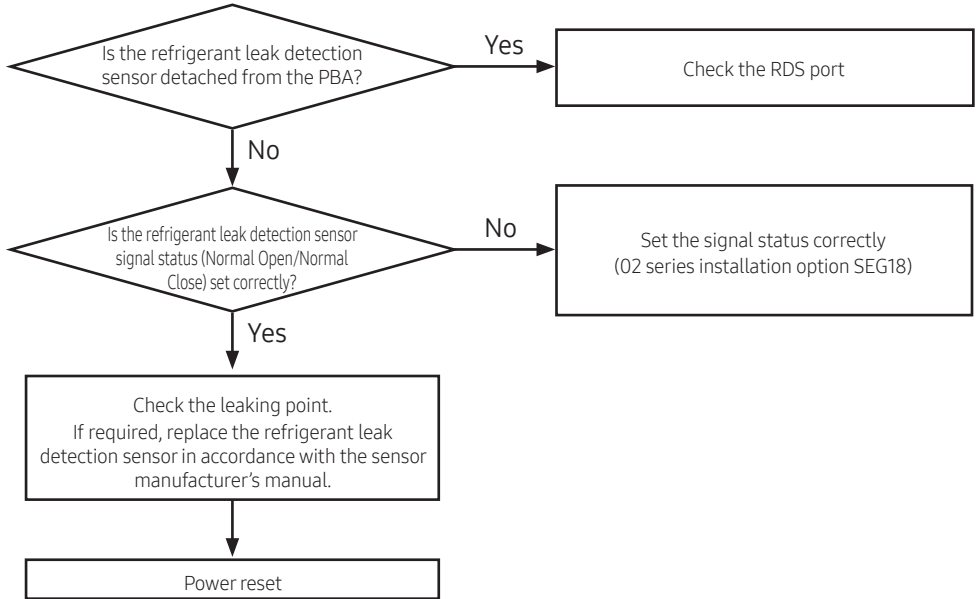

Trouble shooting

Error on DOAS Interface Module temperature sensor OPEN/SHORT

1. Checking method

| | |
|----------------------|---|
| Outdoor unit display | <i>E122</i> (EVA IN sensor OPEN/SHORT) <i>E123</i> (EVA OUT sensor OPEN/SHORT) |
| Description | When the temperature sensor part of DOAS Interface Module is OPEN/SHORT |
| Reason | Loose contact between a sensor and PBA and defective sensor |

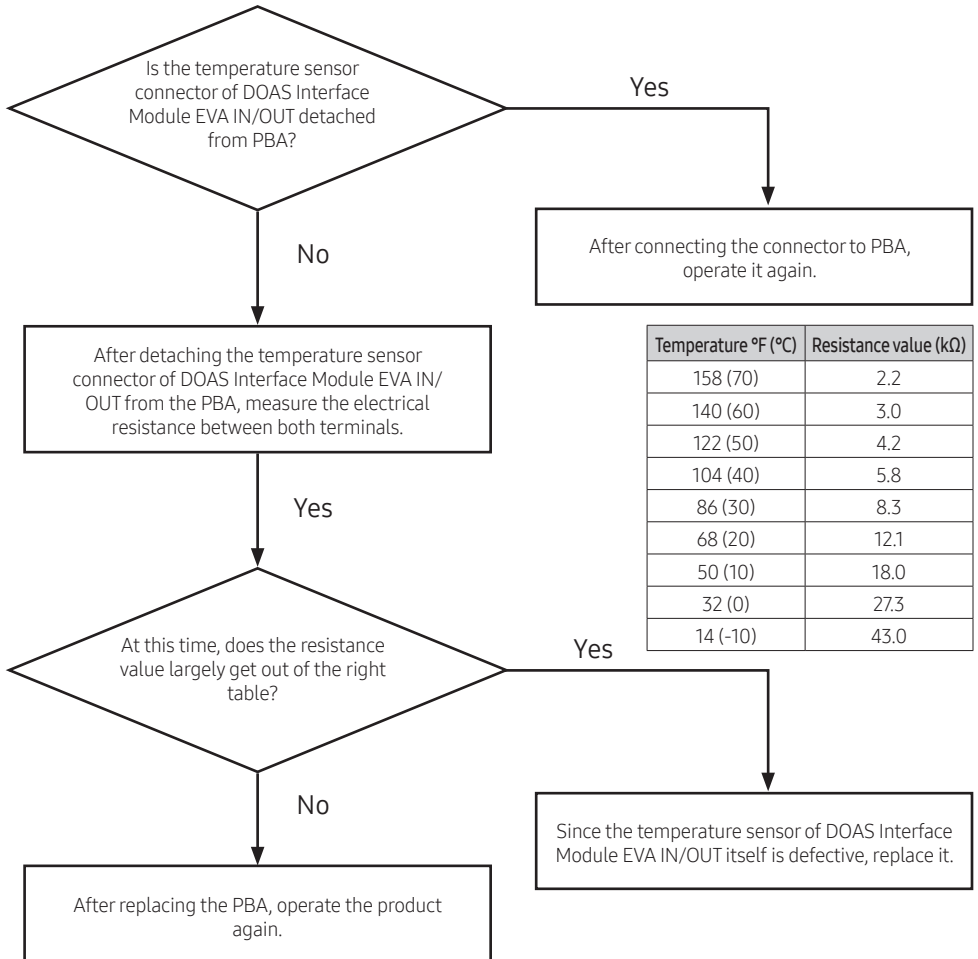

• Wired remote controller will display the same error shown in the outdoor unit.

Error on a fan

| | |
|----------------------|--|
| Outdoor unit display | E154 |
| Description | When the feedback signal is maintained as OPEN status for 10 seconds after outputting the fan operation signal from Control assembly (For DOAS Interface Module) |
| Reason | <ul style="list-style-type: none"> Fan operation of DOAS Interface Module is abnormal. The circuit to detect the fan feedback signal of DOAS Interface Module is not formed or misconnected. |

1. Checking method

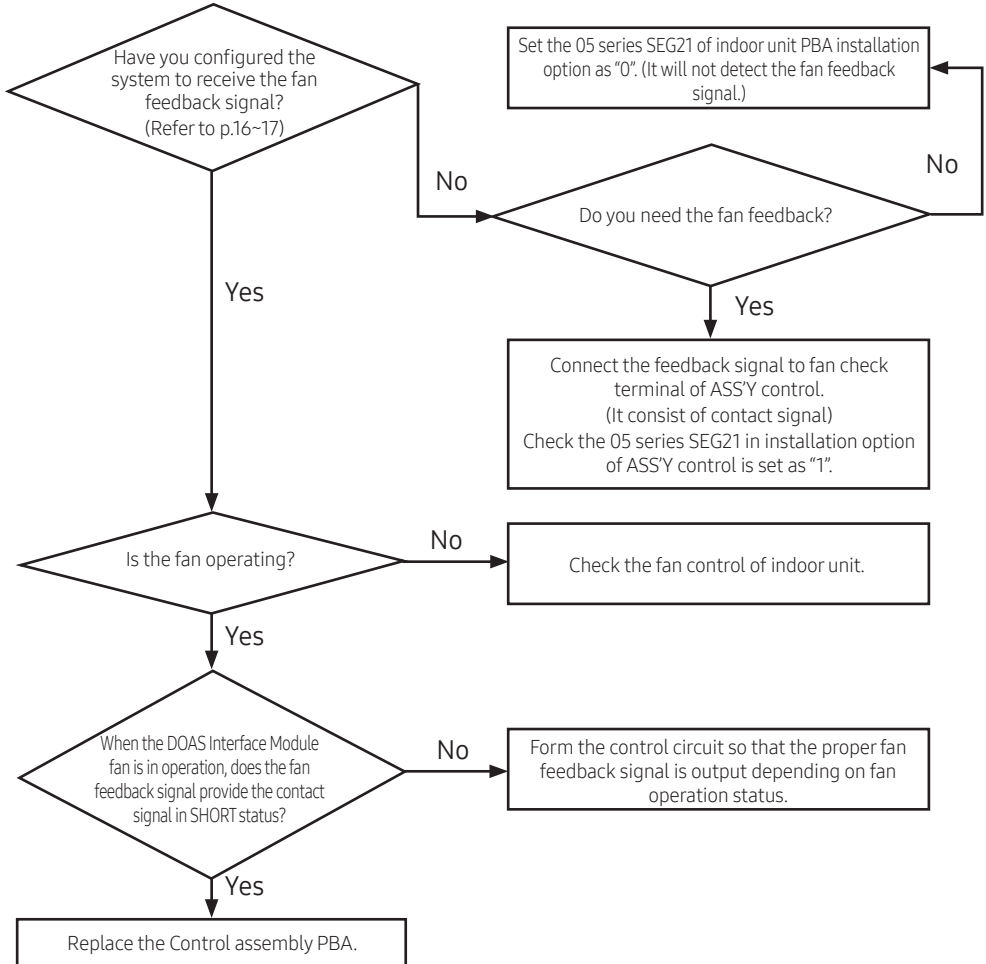

NOTE | Only the contact signal without power supply should be entered to detecting terminal of fan feedback signal. If voltage or current is connected other than the contact signal without power supply, the Control Assembly may be damaged.

Trouble shooting

Error on EEV step control

| | |
|----------------------|---|
| Outdoor unit display | N/A |
| Description | In Cool mode, EEV step is controlled to minimum 230 steps and maximum 1700 steps. In Heat mode, the EEV step is controlled to minimum 1000 steps. |
| Reason | <ul style="list-style-type: none"> • The location of EVA IN/OUT sensor is not correct. • EEV coil is reversed. • All or part of EEV coil is detached. • Refrigerant is overcharged. |

1. Checking method

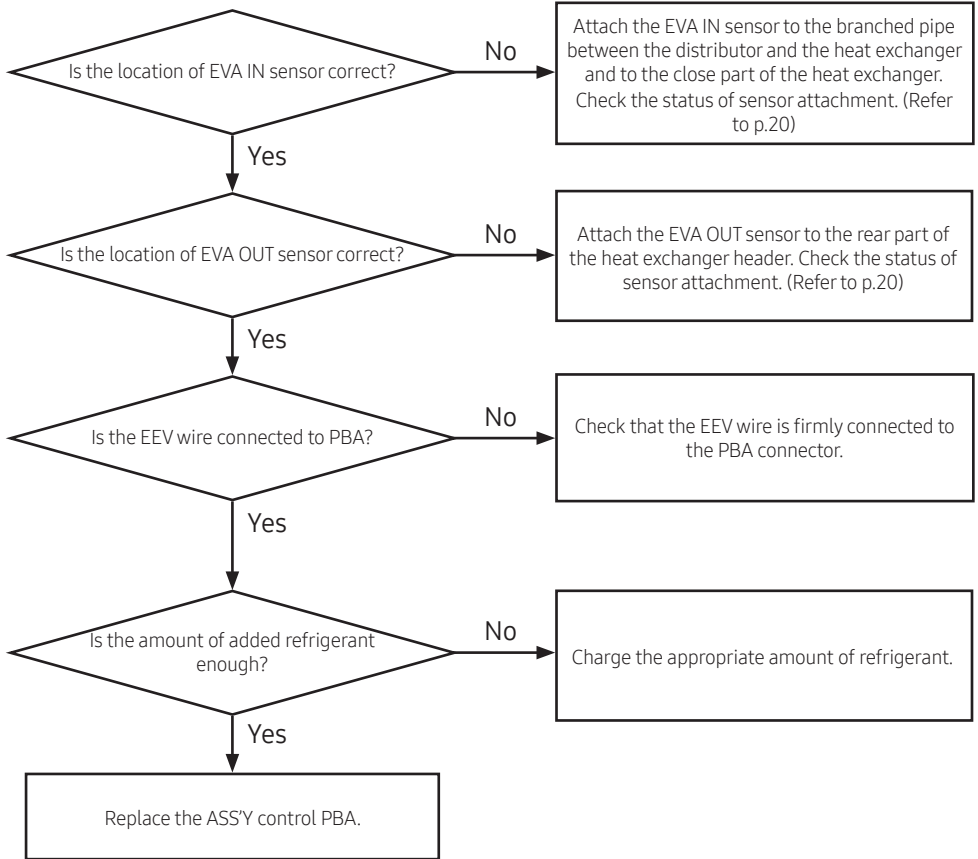

Error on tracking

Communication error between DOAS Interface Module and an outdoor unit during the tracking (During initial operation)

| | |
|----------------------|---|
| Outdoor unit display | <i>E201</i> |
| Description | Communication error between DOAS Interface Module and an outdoor unit |
| Reason | Refer to the diagram below. |

1. Checking method

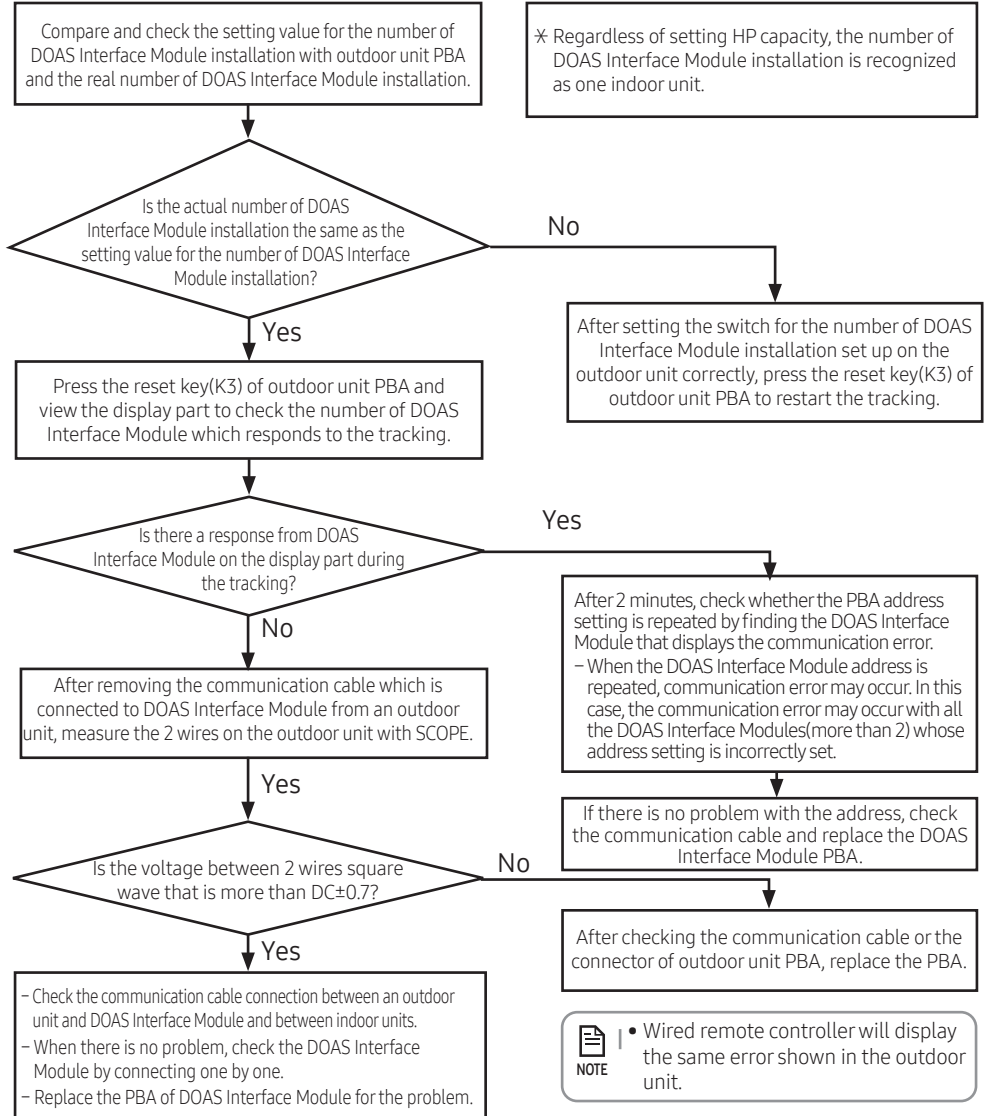

Installation check and test operation

Error on communication between DOAS Interface Module and an outdoor unit after the tracking (During operation)

| | |
|----------------------|--|
| Outdoor unit display | <i>E202</i> |
| Description | When the communication between the DOAS Interface Module and an outdoor unit is not available for 2 minutes during operation. (All rooms) |
| Reason | The communication error between DOAS Interface Module and an outdoor unit or the problem with the setting switch for the number of DOAS Interface Module installation. |

1. Checking method

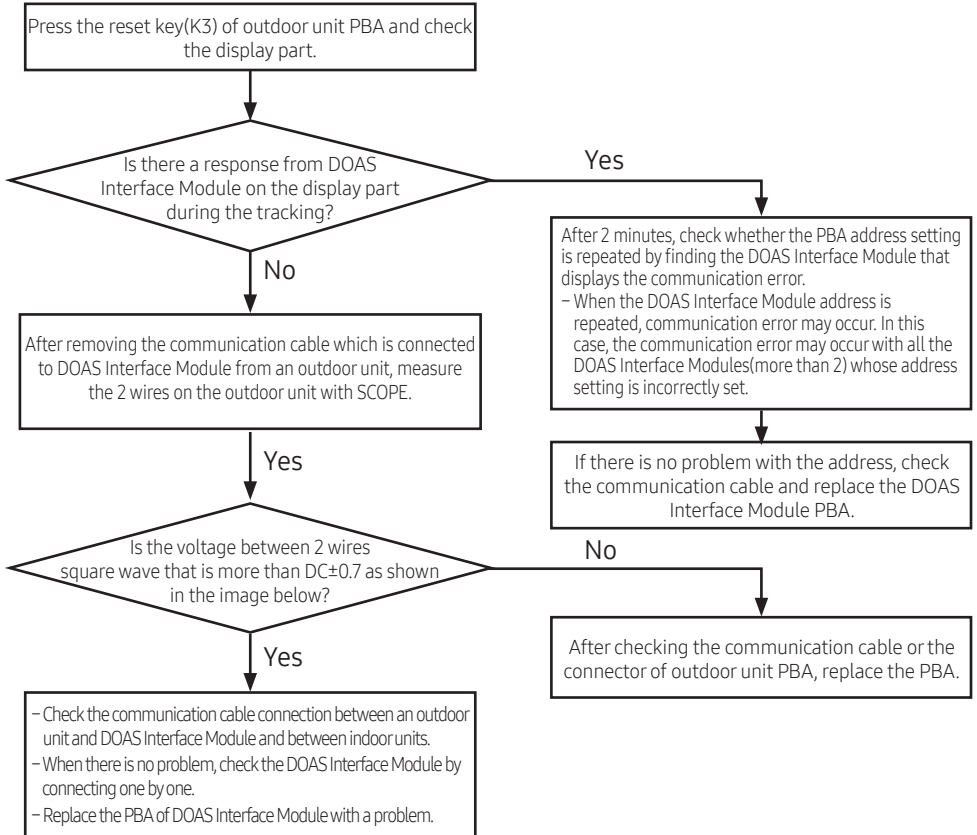

• Wired remote controller will display the same error shown in the outdoor unit.

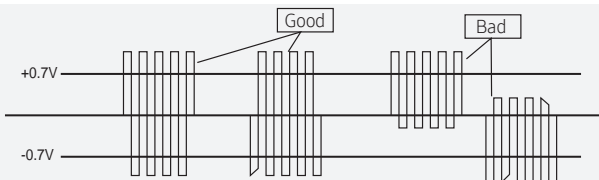

Checking DOAS Interface Module installation

1. Check that Control assembly is correctly installed.

- You can choose either indoor unit attachment type or indoor unit separation type.
- Check the length of connection cable of Control assembly is correct.
- Check that the connection of Control assembly connecting cable is correct.
- Make sure the location has waterproof and fire prevention structure with a specially designed case. (For the separation type, it is essential.)
- Make sure the Control assembly is not exposed to sunlight or rain.

2. Check that the EEV Assembly is correctly installed.

- Check that EEV Assembly is installed inside the indoor unit.
- Check whether IN and OUT pipe connection is correct.
- Must check the EEV Assembly main body is installed vertically.
- Check that the EEV Assembly is installed at the place where condensate water can be drained.

3. Check that the EVA IN/OUT sensor is correctly installed.

- After attaching the EVA IN sensor after the distributor and on the lowest temperature pipe of a heat exchanger, check that you have insulated the attached sensor.
- After installing the EVA OUT sensor 7.87" (200mm) after the header of AHU heat exchanger, check that you have insulated the attached sensor.

4. Amount of additional refrigerant for DOAS Interface Module:

- You must add 0.063kg of refrigerant for every 1 kW of the DOAS Interface Module capacity increase.



- Control assembly should be installed with the CASE that has water proof and fire prevention function.

Installation check and test operation

Test operation

1. **Before supplying power, measure the grounding between the power terminal(1phase: L, N) and DOAS Interface Module using the DC 500 V insulation-resistance tester.**
 - Measured value should be more than 30 MΩ.



CAUTION

- Do not measure the communication terminal as the communication circuit may get damaged.
- For the communication terminal, check the short circuit using a general circuit tester.

2. **After finishing and checking installation and the items below, check that the DOAS Interface Module operates correctly.**
 - The firmness of DOAS Interface Module installation environment and safety
 - Thermal resistance of insulator for refrigerant pipe
 - Leakage of refrigerant gas
 - Drainage status
 - Power connection status
 - Connection status with a circuit breaker and grounding status
 - Correct operation for each operation mode

Memo
