

7-3/8" wide x 8-1/2" tall

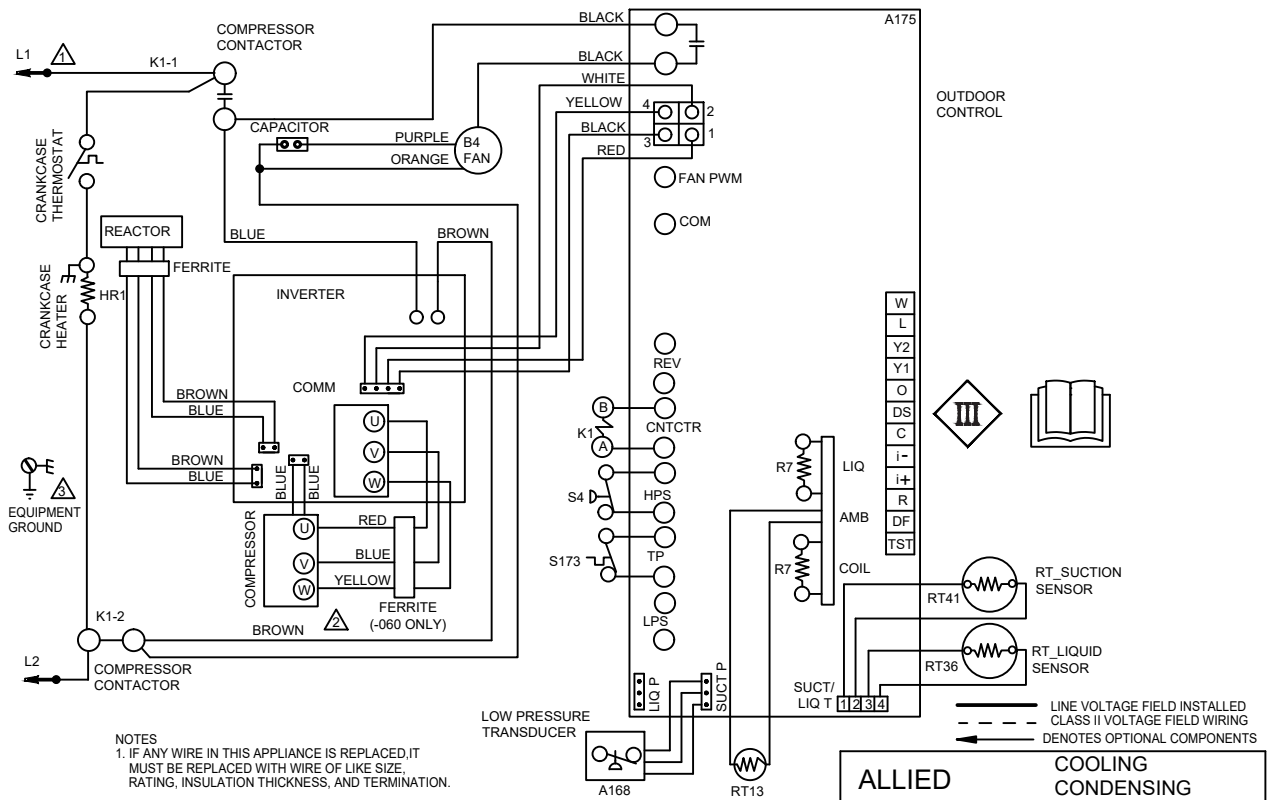
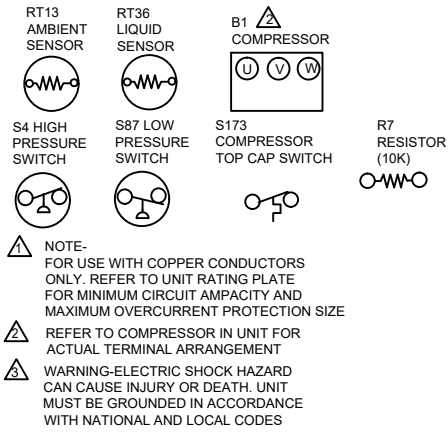
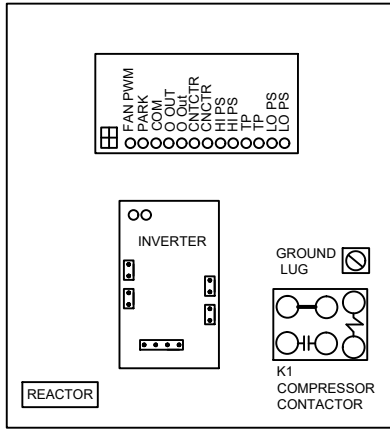

NOTES  
 1. IF ANY WIRE IN THIS APPLIANCE IS REPLACED, IT MUST BE REPLACED WITH WIRE OF LIKE SIZE, RATING, INSULATION THICKNESS, AND TERMINATION.  
 2. THE CONVENTIONAL 24VAC NON-COMM THERMOSTAT MUST HAVE A COMPRESSOR MINIMUM ON TIME OF THREE MINUTES.

<b>ALLIED COOLING CONDENSING</b>	
<b>A7AC19V PSC FAN MOTOR</b>	
Supersedes	
03/26	<b>Form No. 538607-01A</b>