

# INSTALLATION INSTRUCTIONS

## **⚠ WARNING**

To prevent serious injury or death:

- 1- Lock-out/tag-out before performing maintenance.
- 2- If system power is required (e.g., smoke detector maintenance), disable power to blower, remove fan belt where applicable, and ensure all controllers and thermostats are set to the OFF position before performing maintenance.
- 3- Always keep hands, hair clothing, jewelery, tools, etc., away from moving parts.

### Table of Contents

Dimensions . . . . .	4
Parts Arrangement . . . . .	6
Shipping and Packing List . . . . .	7
General . . . . .	7
Requirements . . . . .	7
Unit Support . . . . .	10
Duct Connection . . . . .	11
Rigging Unit for Lifting . . . . .	11
Condensate Drains . . . . .	11
Connect Gas Piping (Gas Units) . . . . .	13
Pressure Test Gas Piping (Gas Units) . . . . .	14
Electrical Connections - Power Supply . . . . .	14
Electrical Connections - Control Wiring . . . . .	15
Mobile Service App . . . . .	17
Blower Operation . . . . .	20
Direct Drive Blower Start-Up . . . . .	22
Refrigerant Leak Detection System . . . . .	25
Cooling Start-Up . . . . .	25
Diagnostic Sensors . . . . .	29
RDS Sensors . . . . .	31

<b>LHT/LDT078</b>	(6.5 Ton)
<b>LHT/LDT092</b>	(7.5 Ton)
<b>LHT/LDT102</b>	(8.5 Ton)
<b>LHT/LDT120</b>	(10 Ton)
<b>LHT/LDT152</b>	(12.5 Ton)

### PACKAGED UNITS

508850-01  
04/2026

**R-454B**

## **⚠ WARNING**

**Improper installation, adjustment, alteration, service or maintenance can cause property damage, personal injury or loss of life. Installation and service must be performed by a licensed professional HVAC installer or equivalent, service agency, or the gas supplier**

Gas Heat Start-Up (LDT) . . . . .	32
Gas Heating Operation . . . . .	34
Gas Heating Checks and Adjustments . . . . .	35
Electric Heat Start-Up (LHT Units) . . . . .	35
Cooling Operation . . . . .	36
Hot Gas Reheat Start-Up and Operation . . . . .	37
Preventative Maintenance / Repair . . . . .	39
Field-Installed Accessories . . . . .	56
Decommissioning . . . . .	59

### RETAIN THESE INSTRUCTIONS FOR FUTURE REFERENCE

#### Attention!

Use this QR code to download the mobile service app. Follow the prompts to pair the app with the Unit Controller. Refer to the "Mobile Service App" section in this manual. The QR code is also available in the unit control area.



The app can be downloaded from the appropriate iOS or Android store. Look for the following icon.



## CAUTION

As with any mechanical equipment, contact with sharp sheet metal edges can result in personal injury. Take care while handling this equipment and wear gloves and protective clothing.

## WARNING

Only manufacturer approved auxiliary devices are permitted to be installed in this unit.

## WARNING

If this appliance is conditioning a space with an area smaller than T<sub>Amin</sub> or stored in a space with an area smaller than A<sub>min</sub> as defined by this instruction, then that space must be without continuously operating open flames (e.g. an operating gas appliance) or other potential ignition sources (e.g. an operating electric heater or similar hot surface). A flame-producing device may be installed in the same space if the device is provided with an effective flame arrest system.

## CAUTION

Auxiliary devices which may be a potential ignition source shall not be installed in the duct work. Examples of such potential ignition sources are hot surfaces with a temperature exceeding 700°C and electric switching devices.

## CAUTION

The appliance is not to be used by persons (including children) with reduced physical, sensory or mental capabilities, or lack of experience and knowledge, unless they have been given supervision or instruction

## CAUTION

Children should be supervised not to play with the appliance.

## CAUTION

Any personnel installing, decommissioning, or performing maintenance on the unit must be properly trained with A2L refrigerants.

## CAUTION

Servicing shall be performed only as recommended by the manufacturer.

## WARNING

•This appliance must be installed in accordance with local and national wiring regulations.

•If the appliance is not fitted with an option for full disconnection from power, a means of disconnection must be incorporated in the fixed wiring in accordance with national and local wiring regulations.

## CAUTION

Leak Detection System installed. Unit must be powered except for service.

## WARNING

•Do not use means to accelerate the defrosting process or to clean, other than those recommended by the manufacturer.

•The appliance shall be stored in a room without continuously operating ignition sources (for example: open flames, an operating gas appliance, or an operating electric heater).

•Do not pierce or burn.

•Be aware that refrigerants may not contain an odor

## WARNING

Ducts connected to an appliance shall not contain a potential ignition source.

## IMPORTANT

Pipe work, including piping material, pipe routing, and installation shall include protection from physical damage in operation and service, and be in compliance with national and local codes and standards, such as ASHRAE 15, ASHRAE 15.2, IAPMO Uniform Mechanical Code, ICC International Mechanical Code, or CSA B52. All field joints shall be accessible for inspection prior to being covered or enclosed.

## IMPORTANT

Refrigerant sensors for refrigerant detection systems shall only be replaced with sensors specified by the appliance manufacturer.

## CAUTION

This unit is equipped with electrically powered safety measures. To be effective, the unit must be electrically powered at all times after installation, other than when servicing.

## **A2L Refrigerant Considerations**

Ensure that the work area is adequately ventilated before breaking into the system or conducting any hot work. A degree of ventilation shall continue during the period that the work is carried out. The ventilation should safely disperse any released refrigerant and preferably expel it externally into the atmosphere.

Check that cabling will not be subject to wear, corrosion, excessive pressure, vibration, sharp edges or any other adverse environmental effects, taking into account the effects of aging or continual vibration from sources such as compressors or fans.

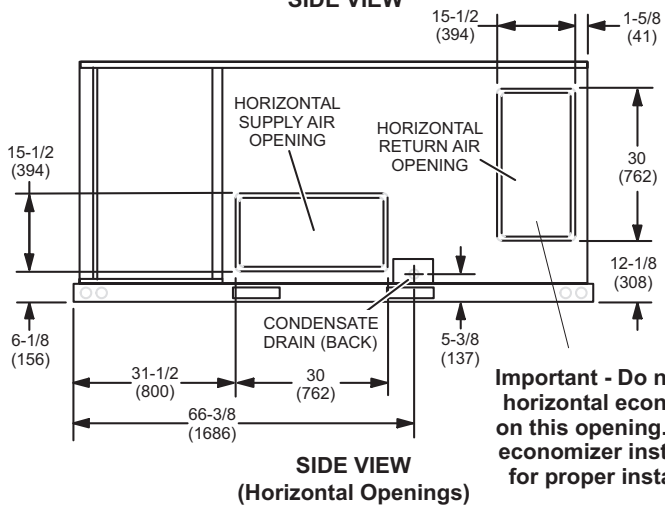
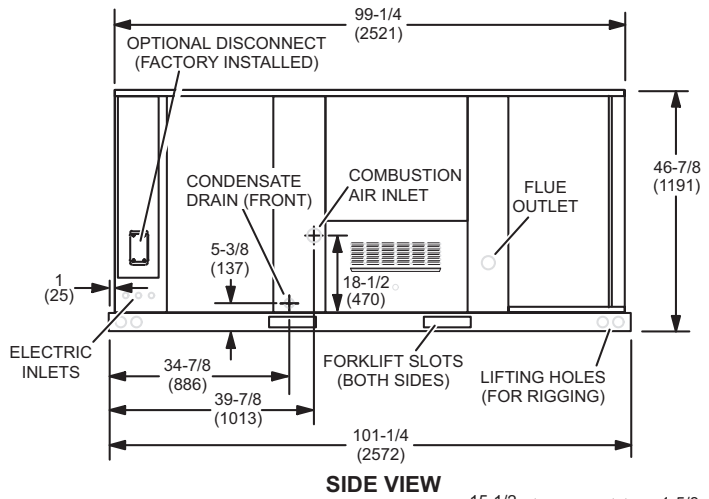
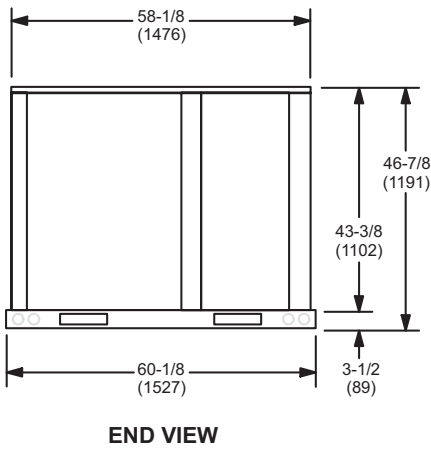
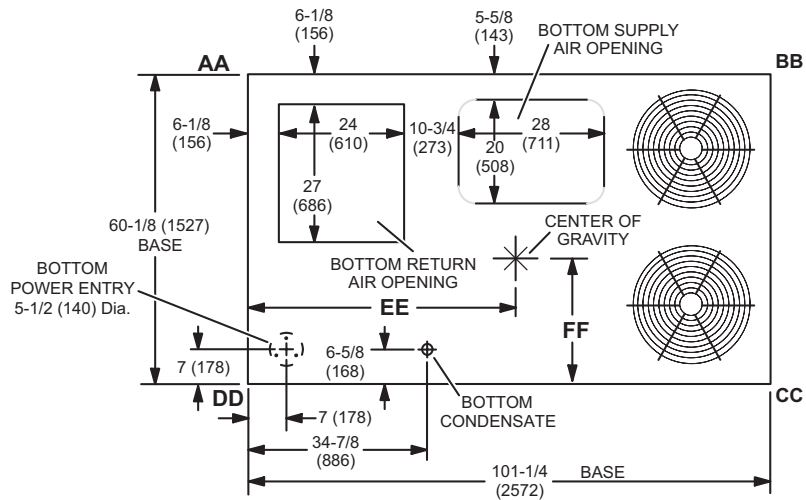
Under no circumstances shall potential sources of ignition be used when searching for or detection of refrigerant leaks. A halide torch (or any other detector using a naked flame) shall not be used. Electronic leak detectors may be used to detect refrigerant leaks but, in the case of flammable refrigerants, the sensitivity may not be adequate, or may need re-calibration. (Detection equipment shall be calibrated in a refrigerant-free area.) Ensure that the detector is not a potential source of ignition and is suitable for the refrigerant used. Leak detection equipment shall be set at a percentage of the LFL of the refrigerant and shall be calibrated to the refrigerant employed, and the appropriate percentage of gas (25% maximum) is confirmed. Leak detection fluids are also suitable for use with most refrigerants but the use of detergents containing chlorine shall be avoided as the chlorine may react with the refrigerant and corrode the copper pipe-work. If a leak is suspected, all naked flames shall be removed/extinguished. If a leakage of refrigerant is found which requires brazing, all of the refrigerant shall be recovered from the system, or isolated (by means of shut off valves) in a part of the system remote from the leak.

When breaking into the refrigerant circuit to make repairs – or for any other purpose – conventional procedures shall be used. However, for flammable refrigerants it is important that best practices be followed since flammability is a consideration. The following procedure shall be adhered to:

- Safely remove refrigerant following local and national regulations.
- Evacuate the circuit.
- Purge the circuit with inert gas.
- Evacuate.
- Purge the circuit with inert gas.
- Open the circuit

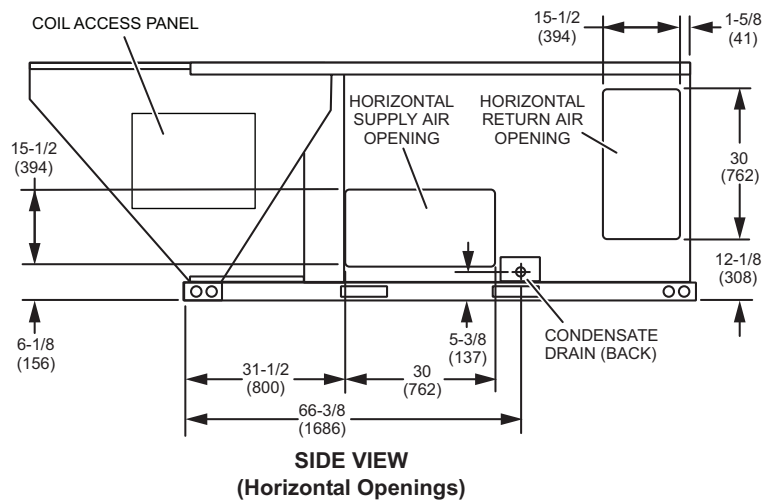
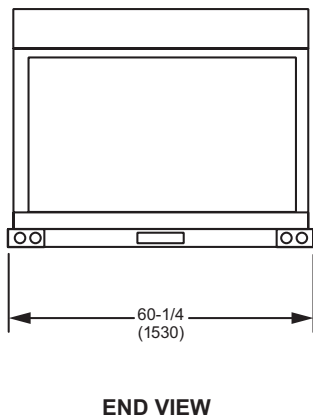
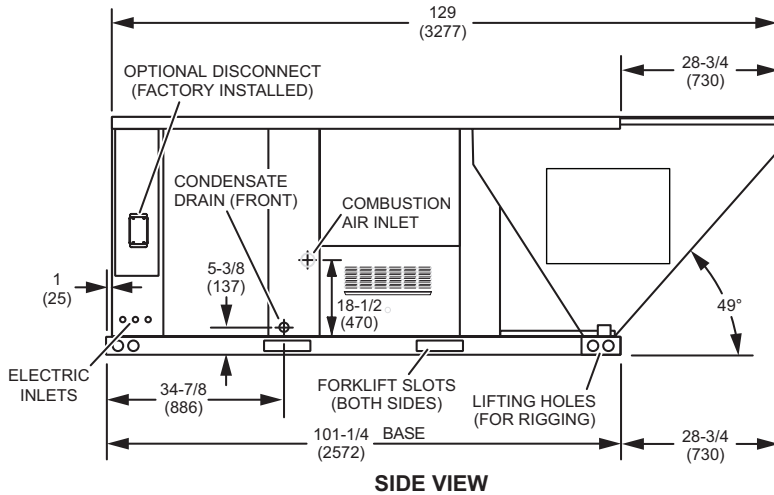
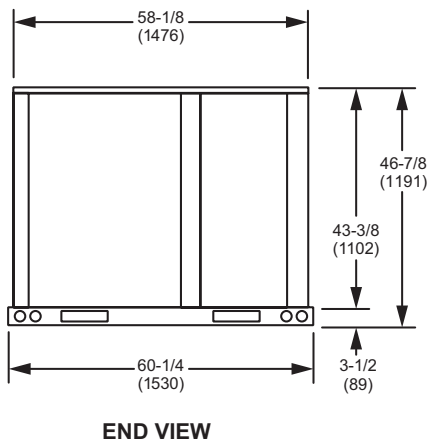
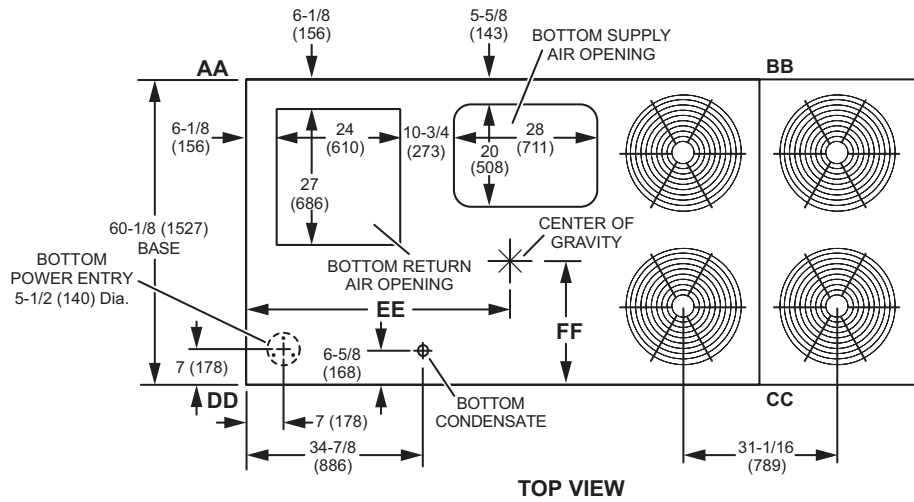
The refrigerant charge shall be recovered into the correct recovery cylinders if venting is not allowed by local and national codes. For appliances containing flammable refrigerants, the system shall be purged with oxygen-free nitrogen to render the appliance safe for flammable refrigerants. This process might need to be repeated several times. Compressed air or oxygen shall not be used for purging refrigerant systems. Refrigerants purging shall be achieved by breaking the vacuum in the system with oxygen-free nitrogen and continuing to fill until the working pressure is achieved, then venting to atmosphere, and finally pulling down to a vacuum. This process shall be vented down to atmospheric pressure to enable work to take place. Ensure that the outlet for the vacuum pump is not close to any potential ignition sources and that ventilation is available.

**LHT/LDT078, 092, 102H, 120H Dimensions - Gas Heat Section Shown**

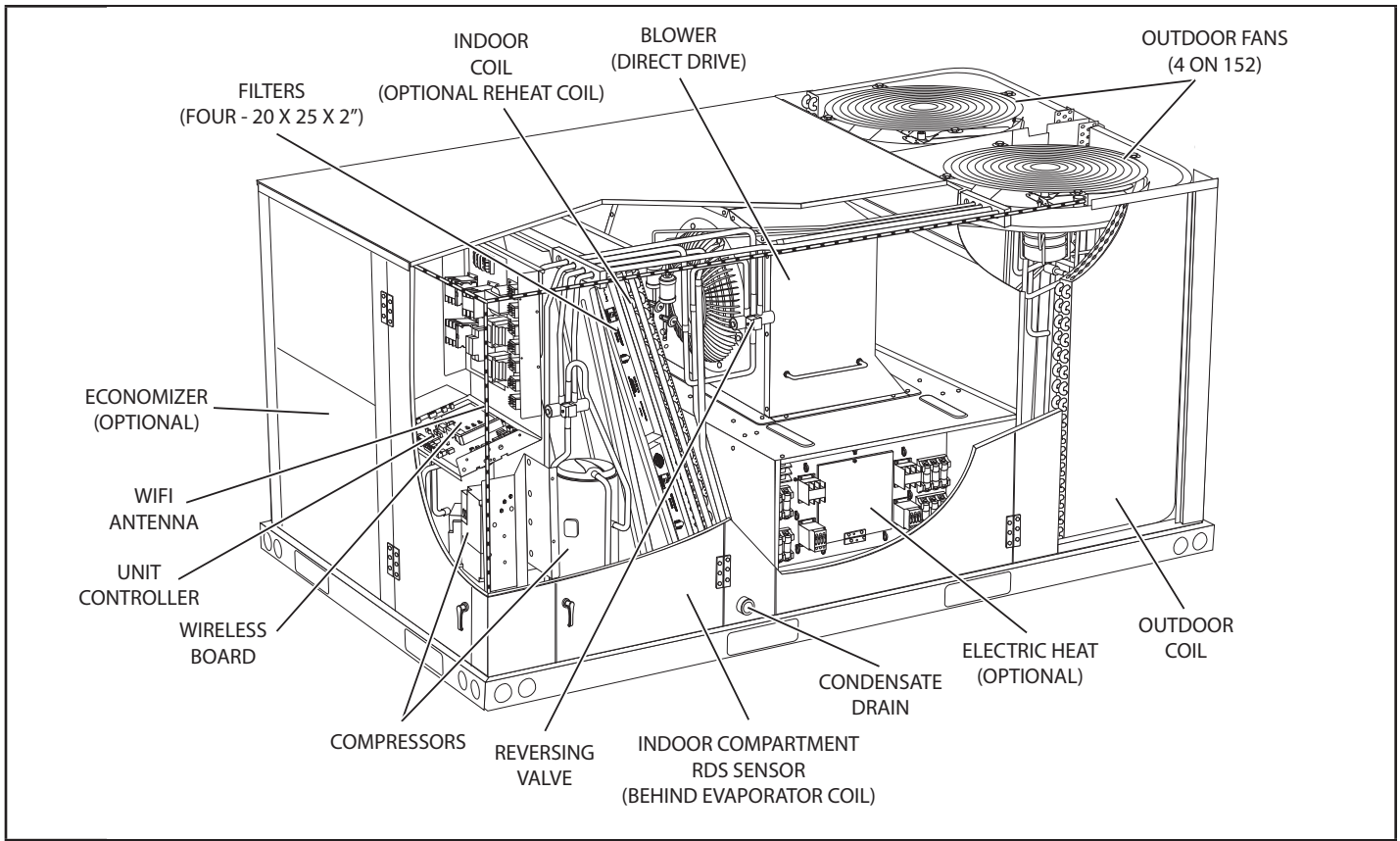


**Important - Do not install horizontal economizers on this opening. Refer to economizer instructions for proper installation.**

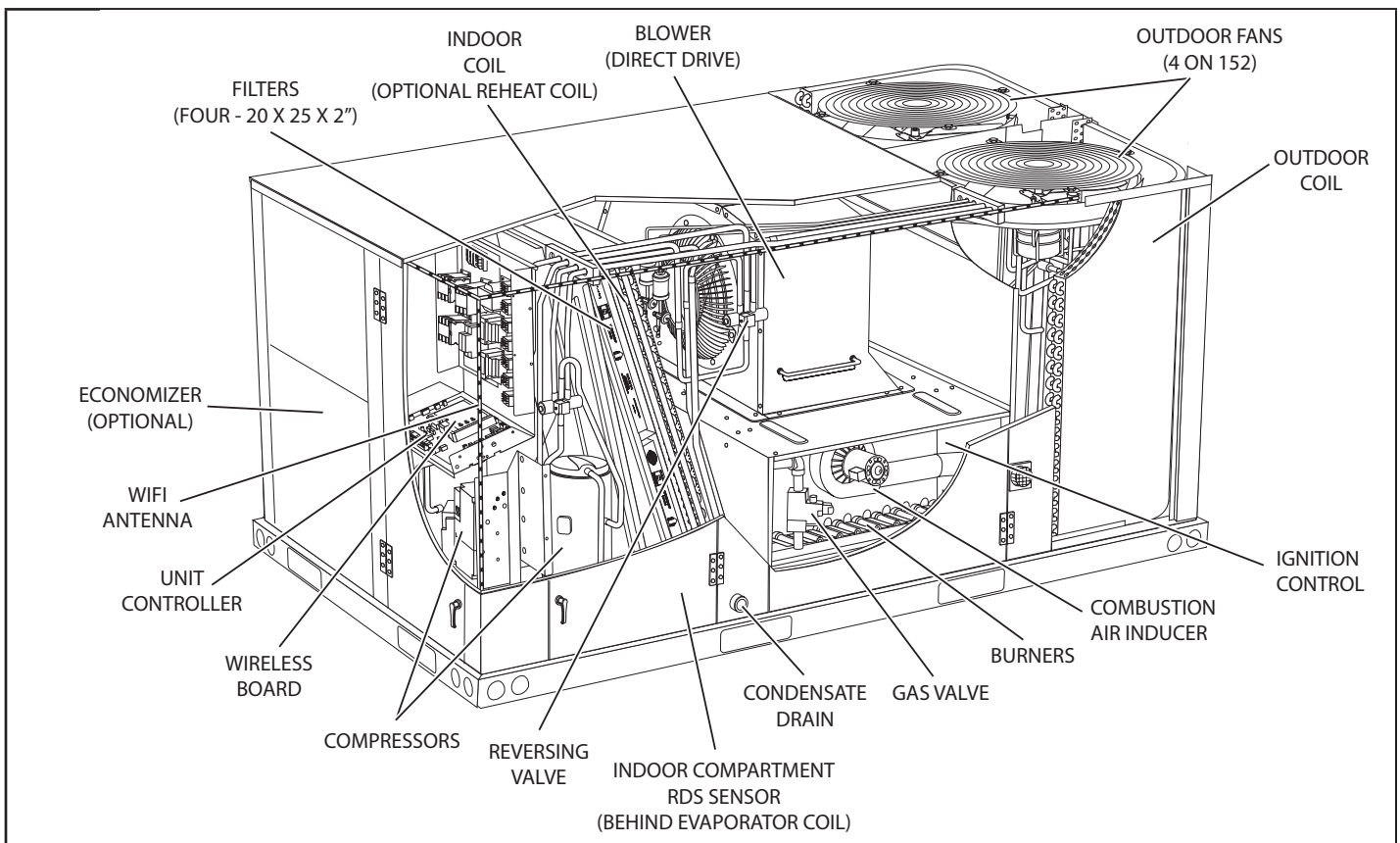
**LHT/LDT152H Dimensions - Gas Heat Section Shown**



**LHT078, 092, 102, 120, 152 Parts Arrangement**



**LDT078, 092, 102, 120, 152 Parts Arrangement**



## Shipping and Packing List

### Package 1 of 1 contains:

1 - Assembled unit

Check unit for shipping damage. Receiving party should contact last carrier immediately if shipping damage is found.

### Top Cap Packaging

Once lumber, bracket, and screws have been removed from the top of the unit, replace the screws in the corners of the cabinet. See FIGURE 2 and FIGURE 3.

## General

These instructions are intended as a general guide and do not supersede local codes in any way. Authorities having jurisdiction should be consulted before installation.

The LDT078, 092, 102, 120, & 152H heat pump/gas heating (dual-fuel) packaged rooftop unit is available in 130,000, 180,000, or 240,000 Btuh heating inputs.

The LHT078, 092, 102, 120, & 152H heat pump packaged rooftop unit is the same basic design as the LDT unit except for the heating section. Optional electric heat is factory- or field-installed in LHT units.

Units are equipped with fin/tube outdoor coils.

Units are equipped with direct drive blowers. The blower will operate at lower speeds when demand is low and increase to higher speeds when demand is high. Refer to the Direct Drive Start-Up section.

Units are available with an optional hot gas reheat coil which provides a dehumidifying mode of operation. Refer to Reheat Operation section.

The following examples show the model numbers of ten ton units with blower options.

LHT/LDT120H5E

Single Zone Staged Direct Drive

All units are available using R454B, an ozone-friendly HFC refrigerant. Refer to the Cooling Start-Up section for precautions when installing unit.

## Requirements

See TABLE 1 for clearances.

## ⚠ WARNING



Electric shock hazard and danger of explosion. Can cause injury, death or product or property damage. Turn off gas and electrical power to unit before performing any maintenance or servicing operations on the unit. Follow lighting instructions attached to unit when putting unit back into operation and after service or maintenance.

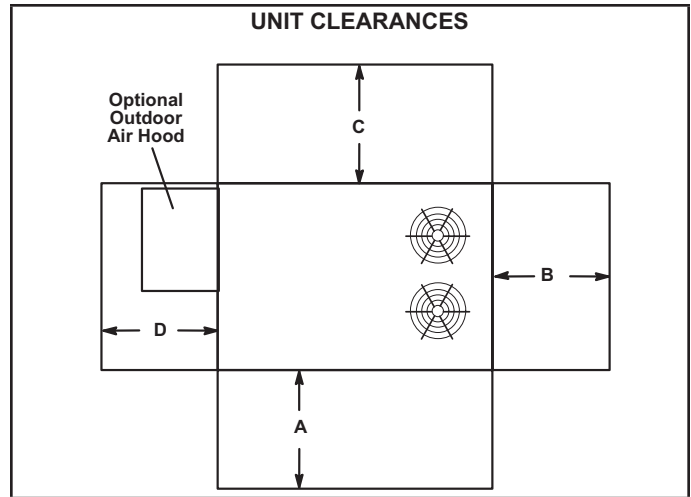


FIGURE 1

TABLE 1  
UNIT CLEARANCES

Unit Clearance	A in.(mm)	B in.(mm)	C in.(mm)	D in.(mm)	Top Clearance
Service Clearance	60 (1524)	36 (914)	36 (914)	66 (1676)	Unobstructed
Clearance to Combustibles	36 (914)	1 (25)	1 (25)	1 (25)	Unobstructed
Minimum Operation Clearance	36 (914)	36 (914)	36 (914)	41 (1041)	Unobstructed

**NOTE** - Entire perimeter of unit base requires support when elevated above mounting surface.

**Service Clearance** - Required for removal of serviceable parts

**Clearance to Combustibles** - Required clearance to combustible material (gas units).

**Minimum Operation Clearance** - Required clearance for proper unit operation.

## ⚠ NOTICE

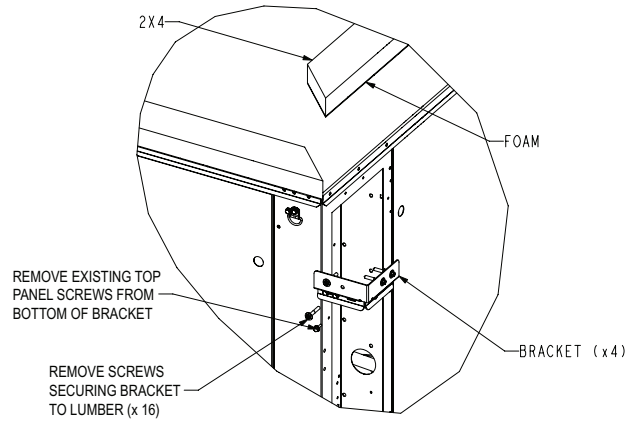
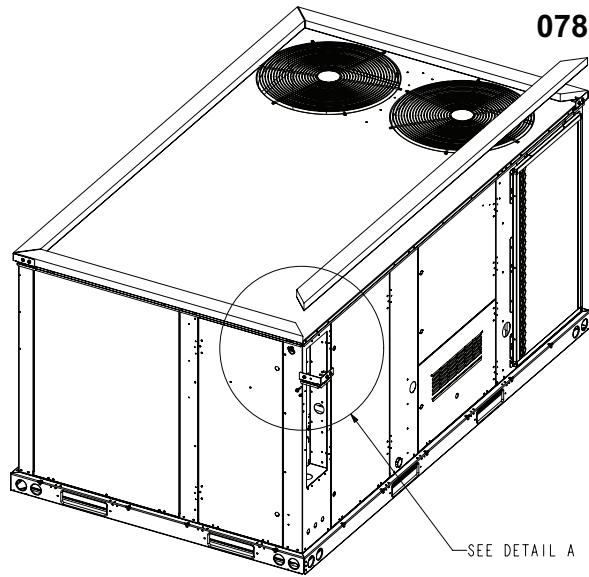
### Roof Damage!

This system contains both refrigerant and oil. Some rubber roofing material may absorb oil, causing the rubber to swell. Bubbles in the rubber roofing material can cause leaks. Protect the roof surface to avoid exposure to refrigerant and oil during service and installation. Failure to follow this notice could result in damage to roof surface.

## ⚠ IMPORTANT

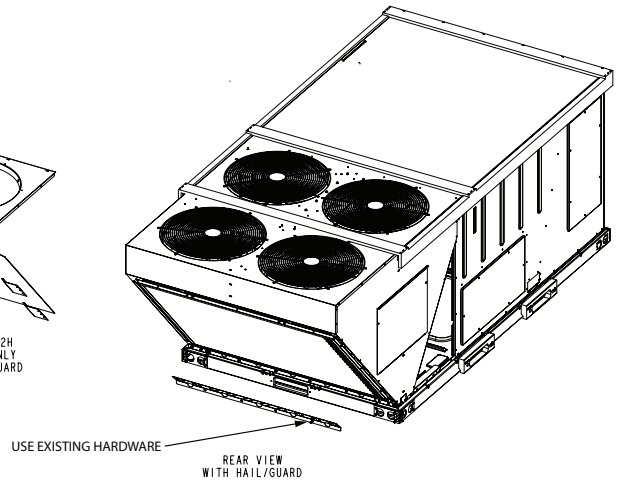
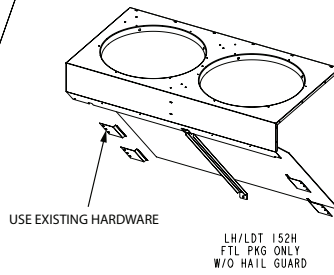
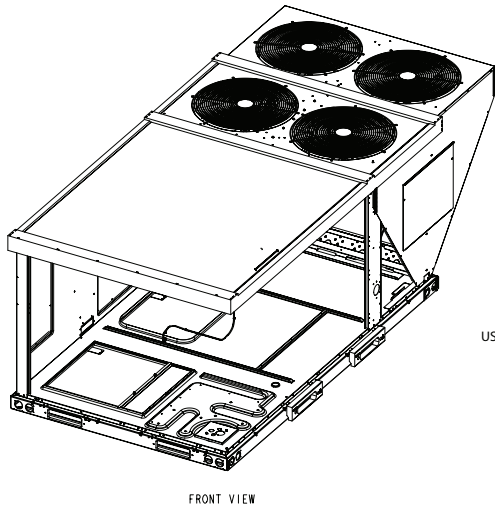
The Clean Air Act of 1990 bans the intentional venting of refrigerant (CFC's and HCFC's) as of July 1, 1992. Approved methods of recovery, recycling or reclaiming must be followed. Fines and/or incarceration may be levied for non-compliance.

**TOP CAP PACKAGING  
078-120 UNITS**



**FIGURE 2**

**TOP CAP PACKAGING  
152 UNITS**



**FIGURE 3**

### Minimum R454B Space and CFM Requirements

Minimum Airflow <sup>1</sup>		
Unit	Q <sub>min</sub> (CFM)	Q <sub>min</sub> (m <sup>3</sup> /h)
LHT/LDT078	304	516
LHT/LDT092	297	505
LHT/LDT102	297	505
LHT/LDT120	283	480
LHT/LDT152	396	674
LHT/LDT078 w/ Humiditrol	344	584
LHT/LDT092 w/ Humiditrol	363	618
LHT/LDT102 w/ Humiditrol	410	696
LHT/LDT120 w/ Humiditrol	357	606
LHT/LDT152 w/ Humiditrol	423	719

Minimum Room Area of Conditioned Space <sup>2</sup>		
Unit	TA <sub>min</sub> (ft <sup>2</sup> )	TA <sub>min</sub> (m <sup>2</sup> )
LHT/LDT078	169	15.7
LHT/LDT092	165	15.3
LHT/LDT102	165	15.3
LHT/LDT120	157	14.5
LHT/LDT152	220	20.4
LHT/LDT078 w/ Humiditrol	191	17.7
LHT/LDT092 w/ Humiditrol	202	18.7
LHT/LDT102 w/ Humiditrol	228	21.1
LHT/LDT120 w/ Humiditrol	198	18.4
LHT/LDT152 w/ Humiditrol	235	21.8

Refrigerant Charge R-454B			
Unit	Stage	M <sub>c</sub> (lbs)	M <sub>c</sub> (kg)
LHT/LDT 078	Stage 1	11.50	5.22
	Stage 2	11.00	4.99
LHT/LDT 092	Stage 1	11.00	4.99
	Stage 2	11.25	5.10
LHT/LDT 102	Stage 1	10.85	4.92
	Stage 2	11.25	5.10
LHT/LDT 120	Stage 1	10.69	4.85
	Stage 2	10.63	4.82
LHT/LDT 152	Stage 1	15.00	6.80
	Stage 2	12.75	5.78
LHT/LDT078 w/ Humiditrol	Stage 1	13.00	5.90
	Stage 2	11.00	4.99
LHT/LDT092 w/ Humiditrol	Stage 1	13.75	6.24
	Stage 2	11.25	5.10
LHT/LDT102 w/ Humiditrol	Stage 1	15.50	7.03
	Stage 2	11.25	5.10
LHT/LDT120 w/ Humiditrol	Stage 1	13.50	6.12
	Stage 2	10.63	4.82
LHT/LDT152 w/ Humiditrol	Stage 1	16.00	7.26
	Stage 2	12.75	5.78

Altitude Adjustment Factor <sup>3</sup>									
Halt	0	200	400	600	800	1000	1200	1400	1600
AF	1	1	1	1	1.02	1.05	1.04	1.1	1.12
Halt	1600	1800	2000	2200	2400	2600	2800	3000	3200
AF	1.12	1.15	1.18	1.21	1.25	1.28	1.32	1.36	1.4

<sup>1</sup> NOTE - The minimum airflow is the lowest CFM allowed during venting operation (leak mitigation).

<sup>2</sup> NOTE - The minimum room area of conditioned space is the smallest area the unit can service.

<sup>3</sup> NOTE - Use the Altitude Adjustment Factor to adjust the values in the tables above to different altitudes. Find the relevant altitude above sea level in the two "Halt" rows and then multiply the value needed from the tables above by the altitude factor number. Example: For the minimum airflow in CFM for an LHT/LDT078 at 1000 ft. above sea level, multiply 304 by 1.05 to get 319.2 CFM as the new Q<sub>min</sub>.

The LHT/LDT unit is ETL/CSA certified for outdoor installations only at the clearances to combustible materials listed on unit nameplate and in FIGURE 1.

Installation of LHT/LDT heat pumps must conform with standards in National Fire Protection Association (NFPA) "Standard for Installation of Air Conditioning and Ventilating Systems NFPA No. 90A," "Standard for Installation of Residence Type Warm Air Heating and Air conditioning Systems NFPA No. 90B," local municipal building codes and manufacturer's installation instructions.

The National Electric Code (ANSI/NFPA No. 70-1984) is available from:

National Fire Protection Association 1  
Batterymarch Park  
PO Box 9101  
Quincy, MA 02269-9101

The LDT unit is ETL/CSA certified as a heat pump with cooling and auxiliary gas heat for non-residential use only at the clearances to combustible materials as listed on the unit nameplate and in FIGURE 1.

Installation of ETL/CSA certified units must conform with current standard C273.5 "Installation Requirements for Heat Pumps" and applicable local codes. Authorities having jurisdiction should be consulted before installation.

Use of this unit as a construction heater or air conditioner is not recommended during any phase of construction. Very low return air temperatures, harmful vapors and operation of the unit with clogged or misplaced filters will damage the unit.

If this unit has been used for heating or cooling of buildings or structures under construction, the following conditions must be met or the warranty will be void:

- A room thermostat or zone air temperature sensor must control the unit. The use of fixed jumpers that will provide continuous heating or cooling is not allowed.
- A pre-filter must be installed at the entry to the return air duct.
- The return air duct must be provided and sealed to the unit.
- Return air temperature range between 55°F (13°C) and 80°F (27°C) must be maintained.
- Air filters must be replaced and pre-filters must be removed upon construction completion.
- The input rate and temperature rise must be set per the unit rating plate.
- The heat exchanger, components, duct system, air filters and indoor coil must be thoroughly cleaned following final construction clean-up.
- The unit operating conditions (including airflow, cooling operation, ignition, input rate, temperature rise and venting) must be verified according to these installation instructions.

This appliance is not intended for use by persons (including children) with reduced physical, sensory, or mental capabilities, or lack of experience and knowledge, unless they have been given supervision or instruction concerning use of the appliance by a person responsible for their safety.

### Unit Support

In downflow discharge installations, install the unit on a non-combustible surface only. Unit may be installed on combustible surfaces when used in horizontal discharge applications or in downflow discharge applications when installed on an C1CURB7\*B roof mounting frame.

**NOTE** - Securely fasten roof frame to roof per local codes.

### CAUTION

To reduce the likelihood of supply / return air by pass and promote a proper seal with the RTU, duct work / duct drops / diffuser assemblies must be supported independently to the building structure.

#### A-Downflow Discharge Application

##### Roof Mounting with C1CURB7\*B

- 1 - The C1CURB7\*B roof mounting frame must be installed, flashed and sealed in accordance with the instructions provided with the frame.
- 2 - The C1CURB7\*B roof mounting frame should be square and level to 1/16" per linear foot (5mm per linear meter) in any direction.
- 3 - Duct must be attached to the roof mounting frame and not to the unit; supply and return plenums must be installed before setting the unit.

##### Installer's Roof Mounting Frame

Many types of roof frames can be used to install the unit depending upon different roof structures. Items to keep in mind when using the building frame or supports are:

- 1 - The base is fully enclosed and insulated, so an enclosed frame is not required.
- 2 - The frames or supports must be constructed with non-combustible materials and should be square and level to 1/16" per linear foot (5mm per linear meter) in any direction.
- 3 - Frame or supports must be high enough to prevent any form of moisture from entering unit. Recommended minimum frame height is 14" (356mm).
- 4 - Duct must be attached to the roof mounting frame and not to the unit. Supply and return plenums must be installed before setting the unit.
- 5 - Units require support along all four sides of unit base. Supports must be constructed of steel or suitably treated wood materials.

**NOTE** - When installing a unit on a combustible surface for downflow discharge applications, an C1CURB7\*B roof mounting frame is required.

## B-Horizontal Discharge Applications

- 1 - Units installed in horizontal airflow applications must use a horizontal conversion kit K1HECK00 and remote discharge sensor kit 21Z08.
- 2 - Specified installation clearances must be maintained when installing units. Refer to FIGURE 1.
- 3 - Top of support slab should be approximately 4" (102mm) above the finished grade and located so no run-off water from higher ground can collect around the unit.
- 4 - Units require support along all four sides of unit base. Supports must be constructed of steel or suitably treated wood materials.

### Duct Connection

All exterior ducts, joints and openings in roof or building walls must be insulated and weather-proofed with flashing and sealing compounds in accordance with applicable codes. Any duct passing through an unconditioned space must be insulated.

## ⚠ CAUTION

In downflow applications, do not drill or punch holes in base of unit. Leaking in roof may occur if unit base is punctured.

### Rigging Unit for Lifting

Rig unit for lifting by attaching four cables to holes in unit base rail. See FIGURE 4.

- 1 - Detach wooden base protection before rigging.  
**NOTE** - Remove all 7 base protection brackets before setting unit.
- 2 - Connect rigging to the unit base using both holes in each corner.
- 3 - All panels must be in place for rigging.
- 4 - Place field-provided H-style pick in place just above top edge of unit. Frame must be of adequate strength and length. (H-style pick prevents damage to unit.)

### Condensate Drains

Make drain connection to the 1" N.P.T. drain coupling provided on unit.

**NOTE** - The drain pan is made with a glass reinforced engineered plastic capable of withstanding typical joint torque but can be damaged with excessive force. Tighten pipe nipple hand tight and turn an additional quarter turn.

A trap must be installed between drain connection and an open vent for proper condensate removal. See FIGURE 5 or FIGURE 6. It is sometimes acceptable to drain condensate onto the roof or grade; however, a tee should be fitted to the trap to direct condensate downward. The condensate line must be vented. Check local codes concerning condensate disposal. Refer to page 1 and page 4 for condensate drain location.

## RIGGING

Unit	*Weight	
	Lbs.	Kg.
078-152	1514	687

\*Maximum weight with all available factory-installed accessories.

CAUTION - Do not walk on unit.

IMPORTANT - ALL PANELS MUST BE IN PLACE FOR RIGGING.  
LIFTING POINT SHOULD BE DIRECTLY ABOVE CENTER OF GRAVITY

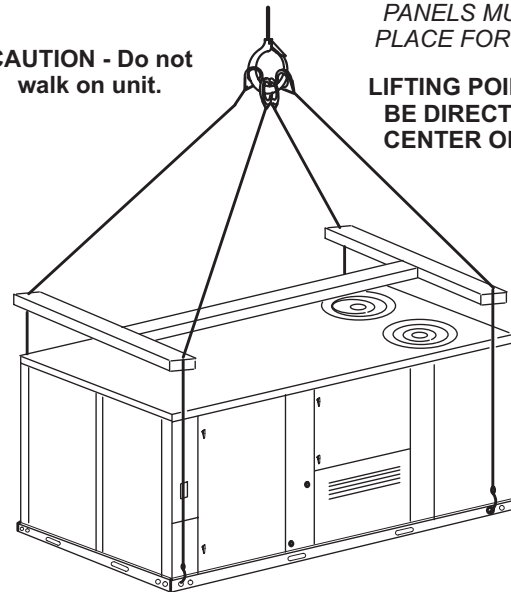


FIGURE 4

## CONDENSATE SIDE DRAIN CONNECTION

CAULK AROUND CONDENSATE COUPLING

NOTE - Allow clearance to open doors when installing condensate piping.

Minimum Pitch  
1" (25 mm) per  
10' (3 m) of line

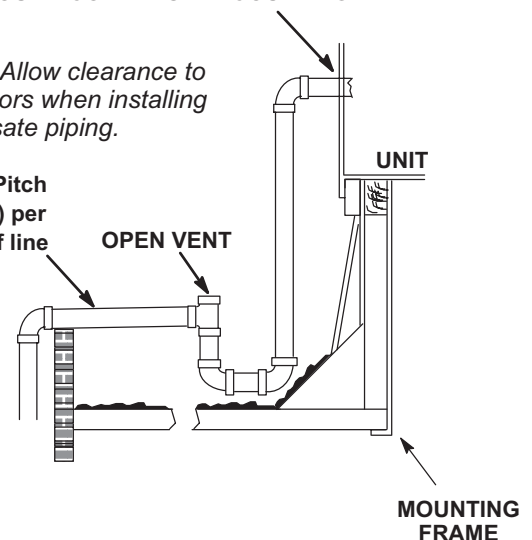
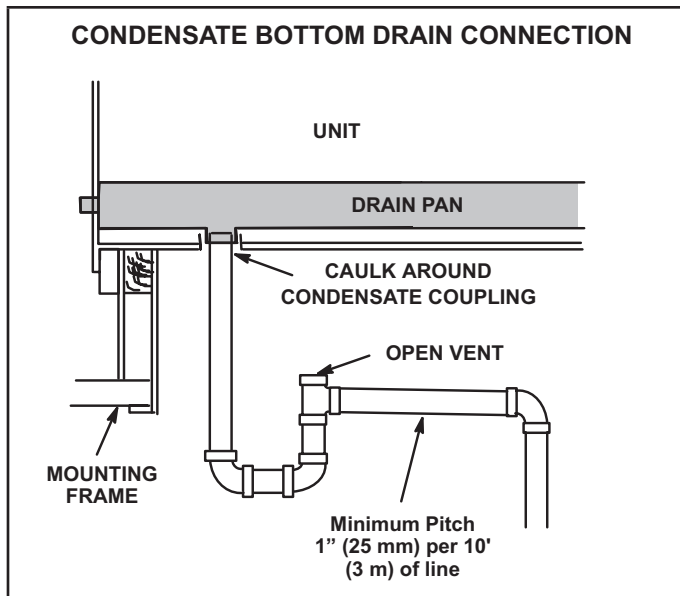


FIGURE 5

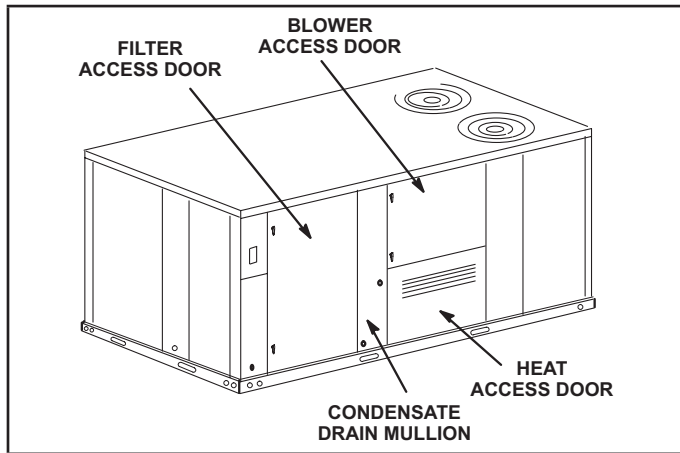


**FIGURE 6**

Units are shipped with the drain coupling facing the front of the unit. Condensate can be drained from the back or bottom of the unit with the following modifications. The unit can be installed in either downflow or horizontal air discharge regardless of condensate drain location.

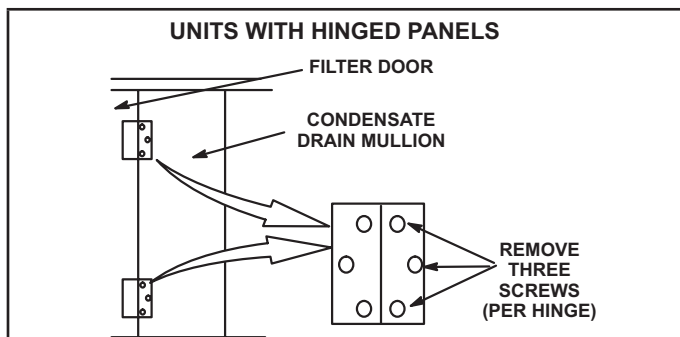
**Rear Drain Connection**

- 1 - Open blower and heat access doors. See FIGURE 7.



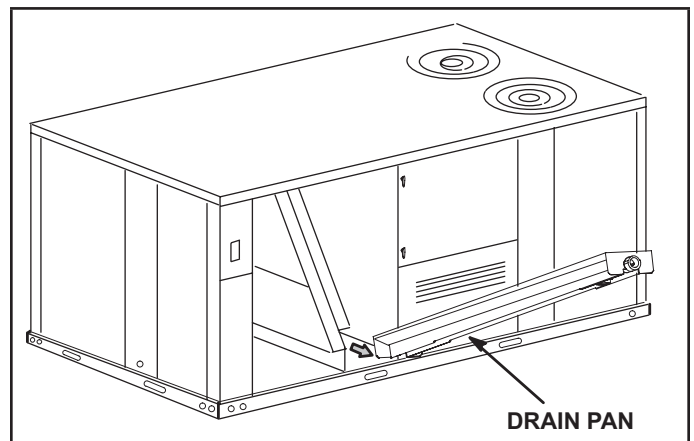
**FIGURE 7**

- 2 - Remove six screws from filter access door. Refer to FIGURE 8.



**FIGURE 8**

- 3 - Open filter access door hinges and carefully remove door.
- 4 - Remove eight screws holding condensate drain mullion and remove mullion.
- 5 - Lift front edge of the drain pan (to clear bottom drain plug) and slide drain pan out of unit. See FIGURE 9.

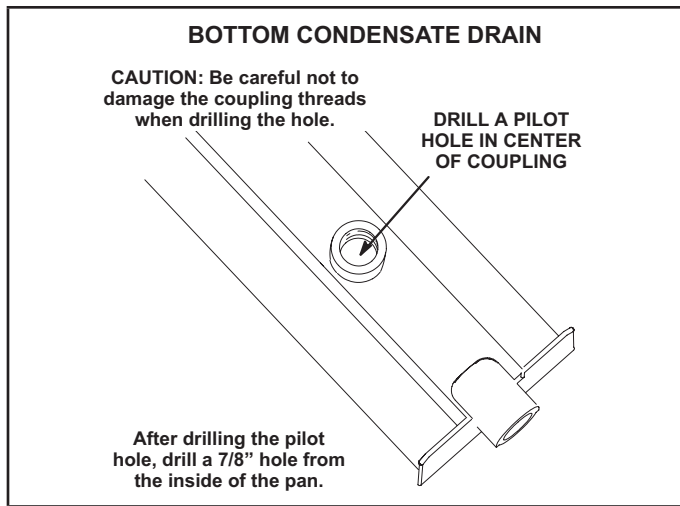


**FIGURE 9**

- 6 - Make sure the cap over the unit bottom drain hole is secure.
- 7 - Rotate the drain pan until the downward slope is toward the back of the unit. Slide the drain pan back into the unit. Be careful not to dislodge the cap over the bottom drain hole.
- 8 - From the back side of the unit, pull the drain pan coupling through the rear condensate opening.
- 9 - Replace the condensate drain mullion and reinstall eight screws.
- 10 - Reinstall filter door on hinges.

**Bottom Drain Connection**

- 1 - Open blower and heat access doors. See FIGURE 7.
- 2 - Remove six screws from filter access door. Refer to FIGURE 8.
- 3 - Open filter access door hinges and carefully remove door.
- 4 - Remove eight screws holding condensate drain mullion and remove mullion.
- 5 - Lift front edge of the drain pan (to clear bottom drain plug) and slide drain pan out of unit. See FIGURE 9.
- 6 - Turn the drain pan upside down and drill a pilot hole through the bottom of the drain pan in the center of the coupling. See FIGURE 10.
- 7 - From the inside of the pan, use a Vari-Bit® bit to enlarge the hole to 7/8". Do not damage coupling threads.
- 8 - Remove the cap over the unit bottom drain hole.
- 9 - Slide the drain pan back into the unit.
- 10 - From the back side of the unit, pull the drain pan coupling through the rear condensate opening.



**FIGURE 10**

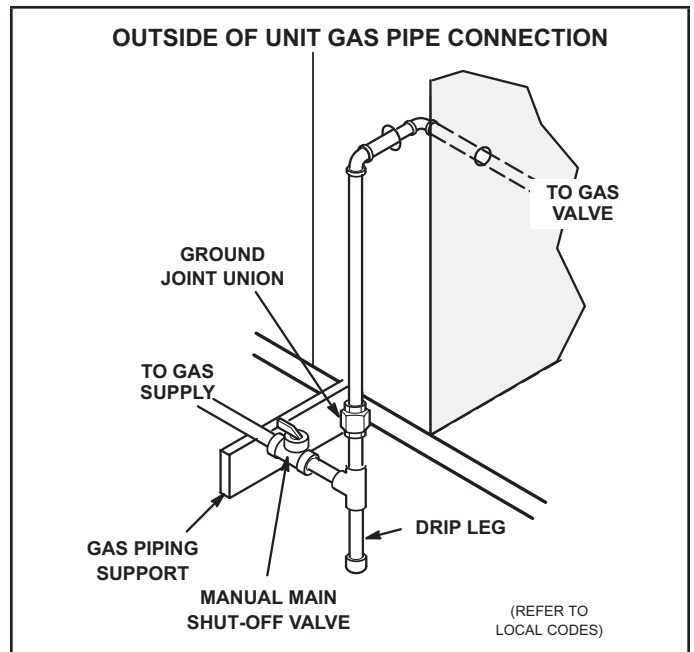
- 11 - From the front side of the unit, move the drain pan until the bottom coupling settles into the unit bottom drain opening. Once in place, check to make sure the coupling is still positioned through the rear condensate drain hole.
- 12 - Use a field-provided 1" plug to seal side drain connection.
- 13 - Replace the condensate drain mullion and reinstall eight screws.
- 14 - Reinstall filter door on hinges.

### Connect Gas Piping (Gas Units)

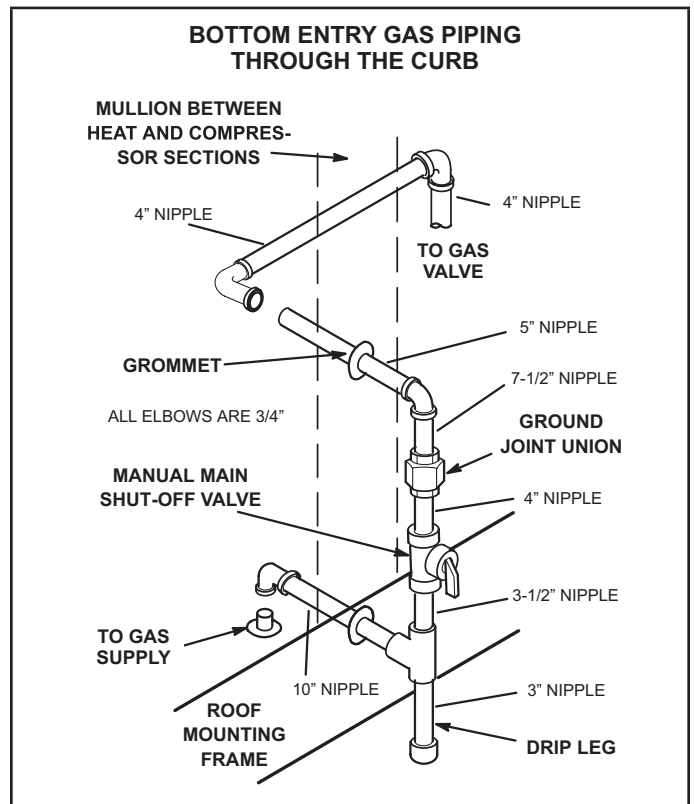
Before connecting piping, check with gas company or authorities having jurisdiction for local code requirements. When installing gas supply piping, length of run from gas meter must be considered in determining pipe size for 0.5" w.c. (.12kPa) maximum pressure drop. Do not use supply pipe smaller than unit gas connection. For natural gas units, operating pressure at the unit gas connection must be a minimum of 4.7" w.c. (1.17kPa) and a maximum of 10.5" w.c. (2.60kPa). For LP/propane gas units, operating pressure at the unit gas connection must be a minimum of 10.8" w.c. (2.69kPa) and a maximum of 13.5" w.c. (3.35kPa).

When making piping connections a drip leg should be installed on vertical pipe runs to serve as a trap for sediment or condensate. Refer to Heating Start-Up section for details regarding measurement of gas supply pressure at the unit. Install a ground joint union between the gas control manifold and the main manual shut-off valve. See FIGURE 11 for gas supply piping entering outside the unit. FIGURE 12 shows bottom gas entry piping through the curb. FIGURE 13 shows bottom gas entry piping through the unit.

Compounds used on threaded joints of gas piping shall be resistant to the action of liquefied petroleum gases.



**FIGURE 11**



**FIGURE 12**

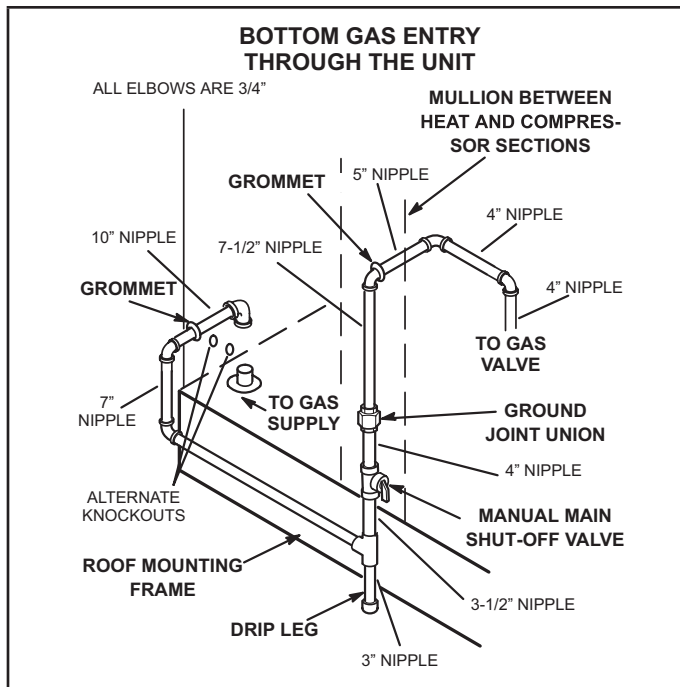


FIGURE 13

### Pressure Test Gas Piping (Gas Units)

When pressure testing gas lines, the gas valve must be disconnected and isolated. Gas valves can be damaged if subjected to more than 0.5 psig (3.48kPa). See FIGURE 14.

**NOTE** - Codes may require that manual main shut-off valve and union (furnished by installer) be installed in gas line external to unit. Union must be of the ground joint type.

After all connections have been made, check all piping connections for gas leaks. Also check existing unit gas connections up to the gas valve; loosening may occur during installation. Use a leak detection solution or other preferred means. Do not use matches candles or other sources of ignition to check for gas leaks.

**NOTE** - In case emergency shut down is required, turn off the main manual shut-off valve and disconnect main power to unit. These devices should be properly labeled by the installer.

### CAUTION

Some soaps used for leak detection are corrosive to certain metals. Carefully rinse piping thoroughly after leak test has been completed. Do not use matches, candles, flame or other sources of ignition to check for gas leaks.

### WARNING



Danger of explosion. Can cause injury or product or property damage. Do not use matches, candles, flame or other sources of ignition to check for leaks.

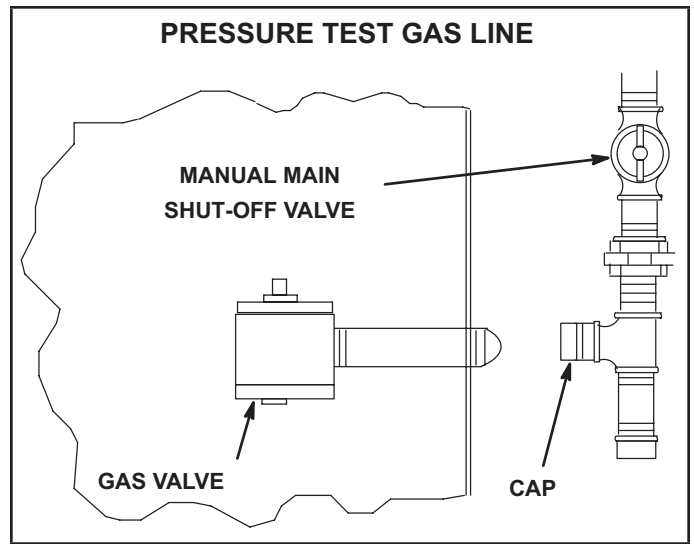


FIGURE 14

### Electrical Connections - Power Supply

Route field wiring in conduit between bottom power entry disconnect. See FIGURE 15. This does not supersede local codes or authorities having jurisdiction.

Do not apply power or close disconnect switch until installation is complete. Refer to start-up directions. Refer closely to unit wiring diagram.

Refer to unit nameplate for minimum circuit ampacity and maximum fuse size.

- 1 - 230/460/575 volt units are factory wired. For **208V supply**, disconnect the orange wire (230V) at all control power transformer(s). Reconnect the red wire (208V). Tape the exposed end of the 230V orange wire.
- 2 - Route power through the bottom power entry area. On gas units or units with electric heat, connect power wiring to TB2. On cooling only units, connect power to F4. If unit contains an optional factory-installed circuit breaker or disconnect switch, connect line voltage to CB10 or S48. See unit wiring diagram.

Connect separate 120v wiring to optional field-powered GFCI outlet. Route field wiring in conduit between bottom power entry and GFCI. See FIGURE 15. For unit-powered GFCI, no additional field wiring is required.

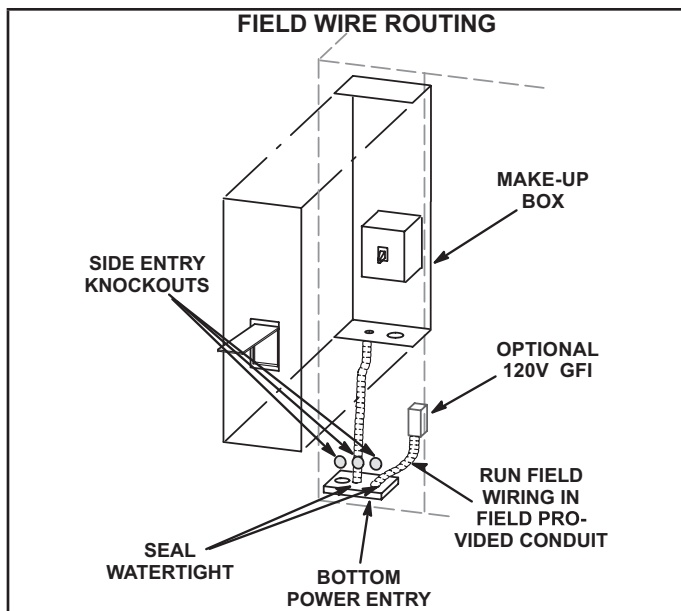


FIGURE 15

### Electrical Connections - Control Wiring

**NOTE** - Optional wireless sensors are available for use with this unit. Refer to the instructions provided with each sensor.

## ⚠ CAUTION

Electrostatic discharge can affect electronic components. Take precautions during unit installation and service to protect the electronic controls. Precautions will help to avoid control exposure to electrostatic discharge by putting the unit, the control and the technician at the same electrostatic potential. Neutralize electrostatic charge by touching hands and all tools on an unpainted unit surface, such as the gas valve or blower deck, before performing any service procedure.

### A-Thermostat Location

Applied to units in default thermostat control mode only. Room thermostat mounts vertically on a standard 2" X 4" handy box or on any non-conductive flat surface.

Locate thermostat approximately 5 feet (1524mm) above the floor in an area with good air circulation at average temperature. Avoid locating the room thermostat where it might be affected by:

- drafts or dead spots behind doors and in corners
- hot or cold air from ducts
- radiant heat from sun or appliances
- concealed pipes and chimneys

**IMPORTANT** - Unless field thermostat wires are rated for maximum unit voltage, they must be routed away from line voltage wiring.

### B-Control Wiring

The Unit Controller will operate the unit from a thermostat

or zone sensor based on the System Mode. The default System Mode is the thermostat mode. Refer to the Unit Controller Setup Guide to change the System Mode. Use the mobile service app menu and select Settings > Install.

### Thermostat Mode

- 1 - Route thermostat cable or wires from subbase to control area above compressor (refer to unit dimensions to locate bottom and side power entry).

**IMPORTANT** - Unless field thermostat wires are rated for maximum unit voltage, they must be routed away from line voltage wiring. Use wire ties located near the lower left corner of the controls mounting panel to secure thermostat cable.

Use 18 AWG wire for all applications using remotely installed electro-mechanical and electronic thermostats.

- 2 - Install thermostat assembly in accordance with instructions provided with thermostat.
- 3 - Connect thermostat wiring to Unit Controller on the lower side of the controls hat section.
- 4 - Wire as shown in FIGURE 16 for electro-mechanical and electronic thermostats. If using other temperature control devices or energy management systems see instructions and wiring diagram provided by manufacturer.

**IMPORTANT** - Terminal connections at the Unit Controller must be made securely. Loose control wire connections may allow unit to operate but not with proper response to room demand.

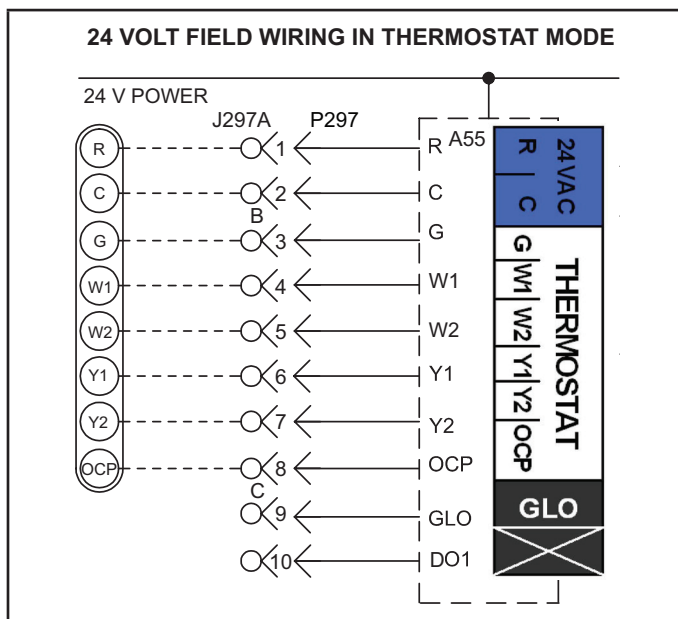


FIGURE 16

### Zone Sensor Mode

The Unit Controller will operate heating and cooling based on the Unit Controller internal setpoints and the temperature from the A2 room sensor. An optional Network Control Panel (NCP) can also be used to provide setpoints. A thermostat or return air sensor can be used as a back-up mode. Make room sensor wiring connections as shown in FIGURE 17.

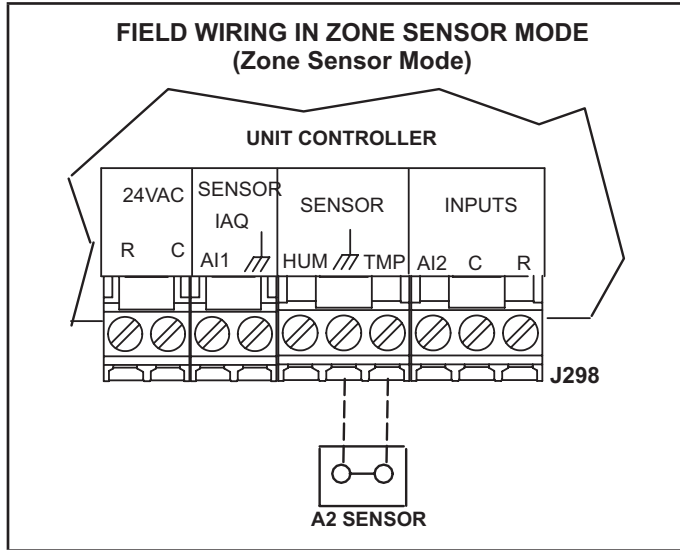


FIGURE 17

### C-Hot Gas Reheat

Install humidity sensor in accordance with instructions provided with sensor. A DDC input may be used to initiate dehumidification instead of a sensor.

Make wiring connections as shown in FIGURE 16 for Thermostat Mode or FIGURE 17 for Zone Sensor Mode. In addition, connect either a humidity sensor or a dehumidification input. See FIGURE 19 or FIGURE 20 for humidity sensor wiring or FIGURE 18 for dehumidification input wiring.

### Humidity Sensor Cable Applications

#### Wire runs of 50 feet (mm) or less

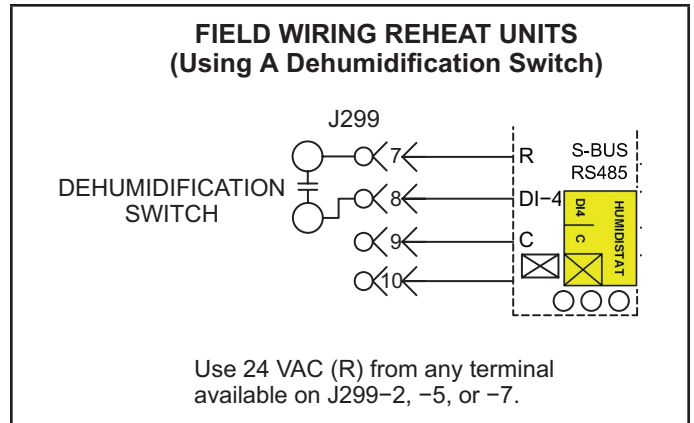
Use two separate shielded cables containing 20AWG minimum, twisted pair conductors with overall shield. Belden type 8762 or 88760 (plenum) or equivalent. Connect both cable shield drain wires to the Unit Controller as shown in FIGURE 19.

#### Wire runs of 150 feet (mm) or less

Use two separate shielded cables containing 18AWG minimum, twisted pair conductors with overall shield. Belden type 8760 or 88760 (plenum) or equivalent. Connect both cable shield drain wires to the Unit Controller as shown in FIGURE 19.

#### Wire runs over 150 feet (mm)

Use a local, isolated 24VAC transformer such as Lennox cat #18M13 (20VA minimum) to supply power to RH sensor as shown in FIGURE 20. Use two shielded cables containing 20AWG minimum, twisted pair conductors with overall shield. Belden type 8762 or 88760 (plenum) or equivalent.



Use 24 VAC (R) from any terminal available on J299-2, -5, or -7.

FIGURE 18

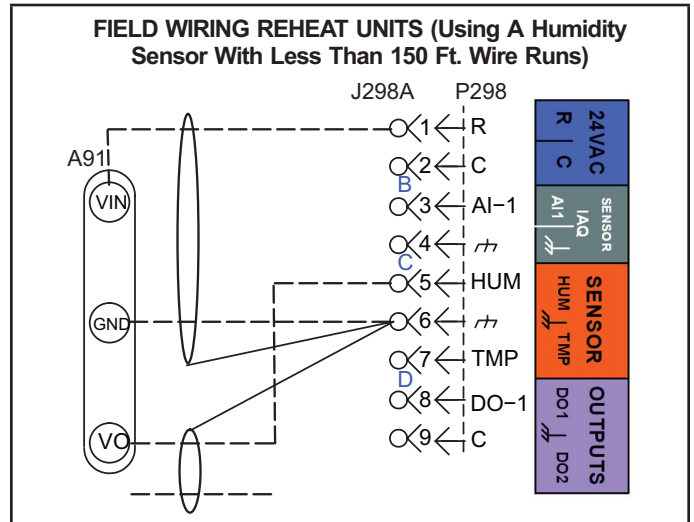


FIGURE 19

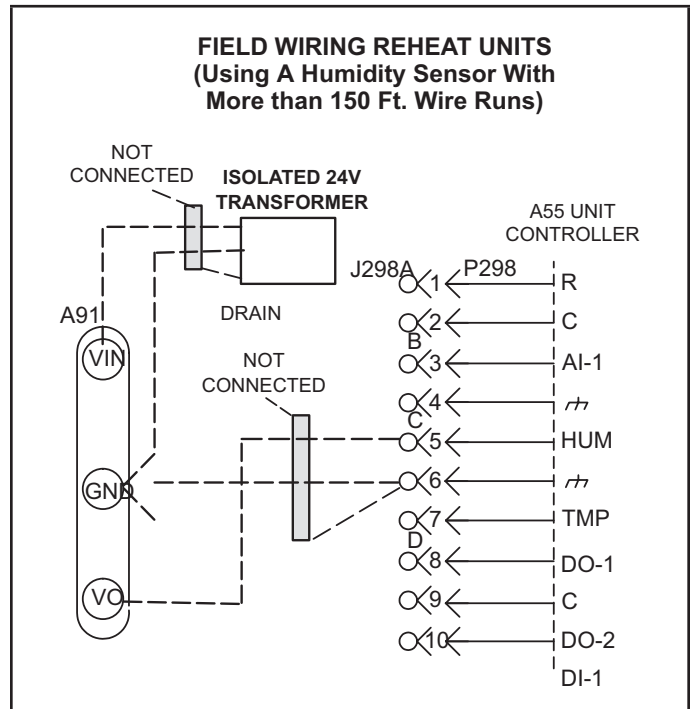


FIGURE 20

## Mobile Service App

Setup and configure each rooftop unit using the mobile service app (Android or iOS devices supported).

### A-Mobile Device Requirements

- Bluetooth connection.
- Android hardware requires 2GB RAM and a 2Ghz core processor. Tablets are supported.
- The app is available for both iOS 11.0 or higher (App Store) and Android 9.0 or higher (Google Play).

### B-Download the App

Use your mobile device to scan the QR code from the cover page and download the mobile service app to your mobile device.

### C-Pair the App to the Unit Controller

- 1 - Apply power to the unit and wait until the Unit Controller has booted-up (approximately two minutes).
- 2 - Press and hold the pair button for five seconds. See FIGURE 22.
- 3 - The unit (or list of units) will appear; select the appropriate unit. When the app code matches the four-character code on the Unit Controller display, the unit is paired (within 10 seconds). Note the following:
  - The app will list the units by signal strength; the RTU name will be displayed.
  - Once paired, the RTU name, model number, serial number and firmware version will be displayed.

Please refer to the manufacturer's website for additional technical information and self-help support.

## D-App Menus

See FIGURE 21 for the menu overview. Follow the app prompts in the Install, Network Integration, and Test and Balance menus. Verify the app is setup properly for the unit application (including the date and time). Refer to FIGURE 23, FIGURE 24, and FIGURE 25.

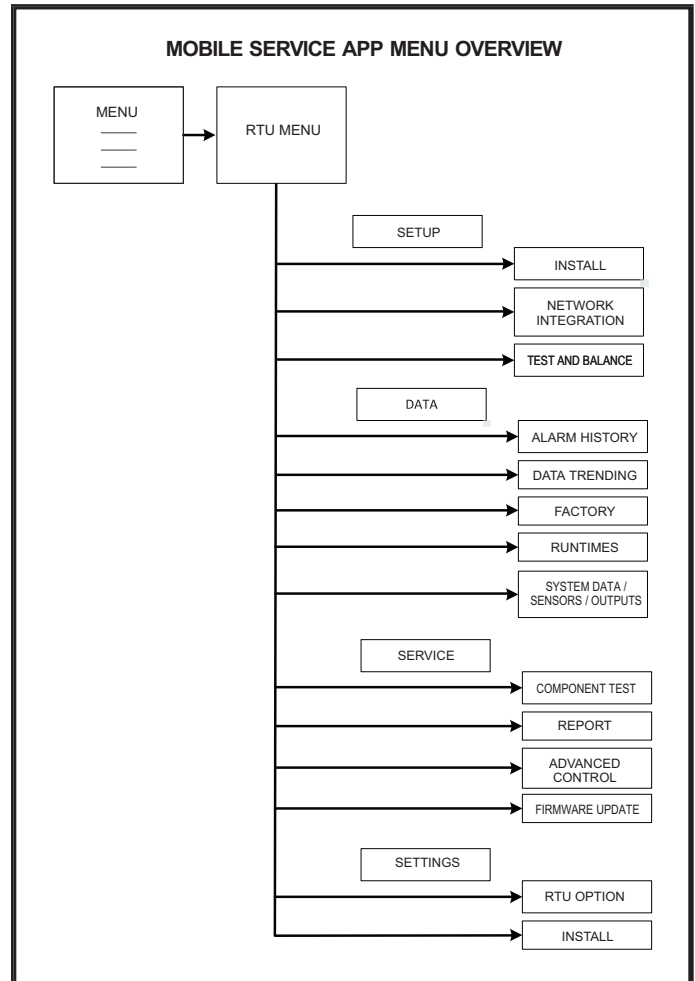


FIGURE 21

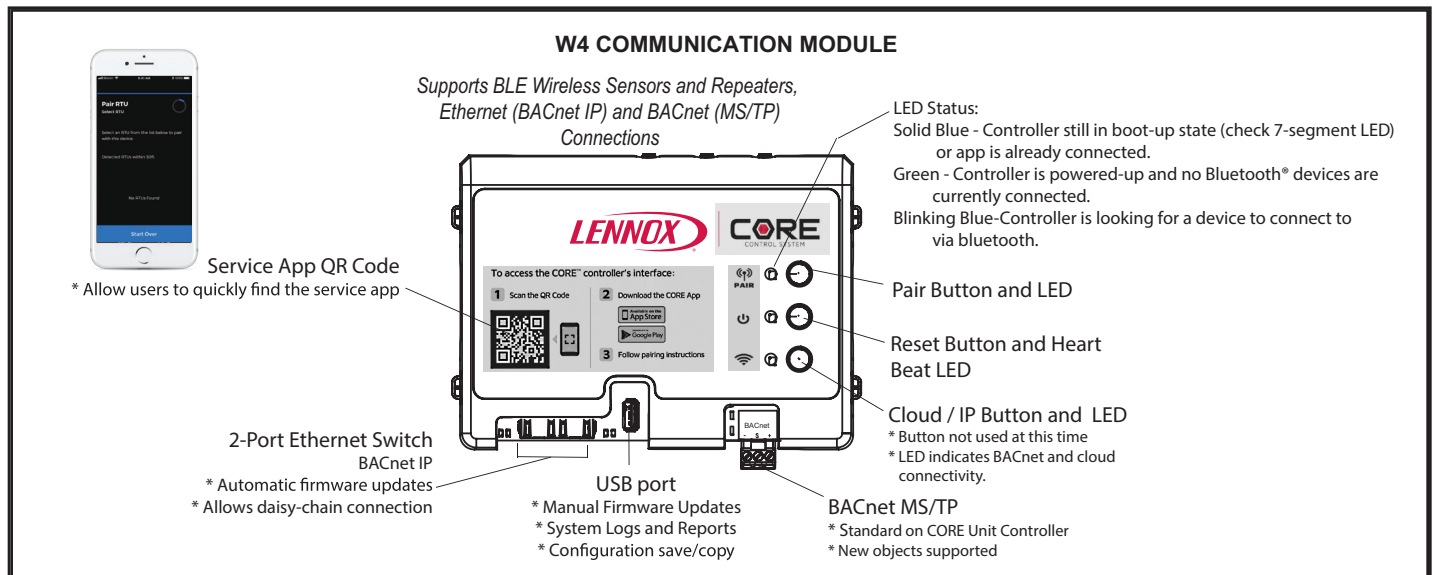


FIGURE 22

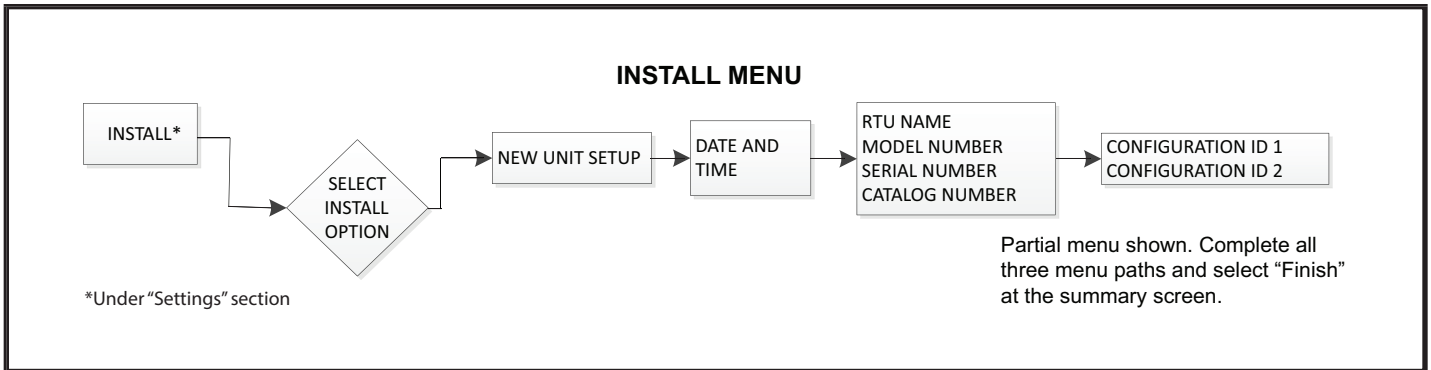


FIGURE 23

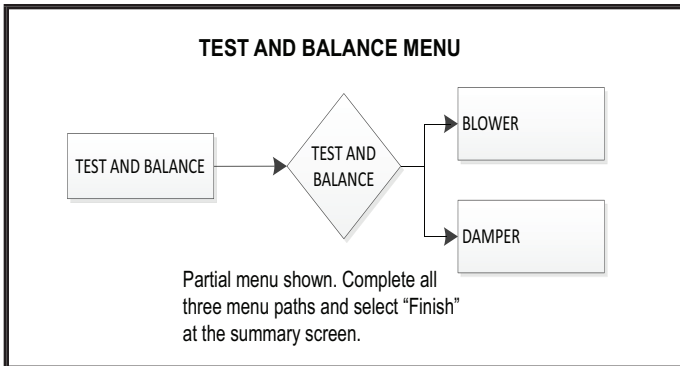


FIGURE 24

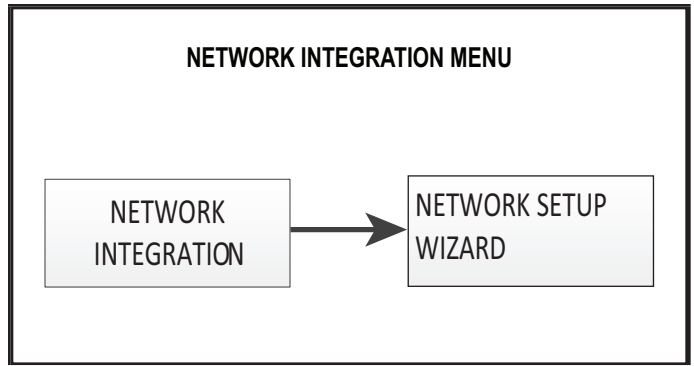


FIGURE 25

## E-Unit Controller Components

See FIGURE 26 for Unit Controller components. See FIGURE 27 and TABLE 2 for pushbutton and LED functions.

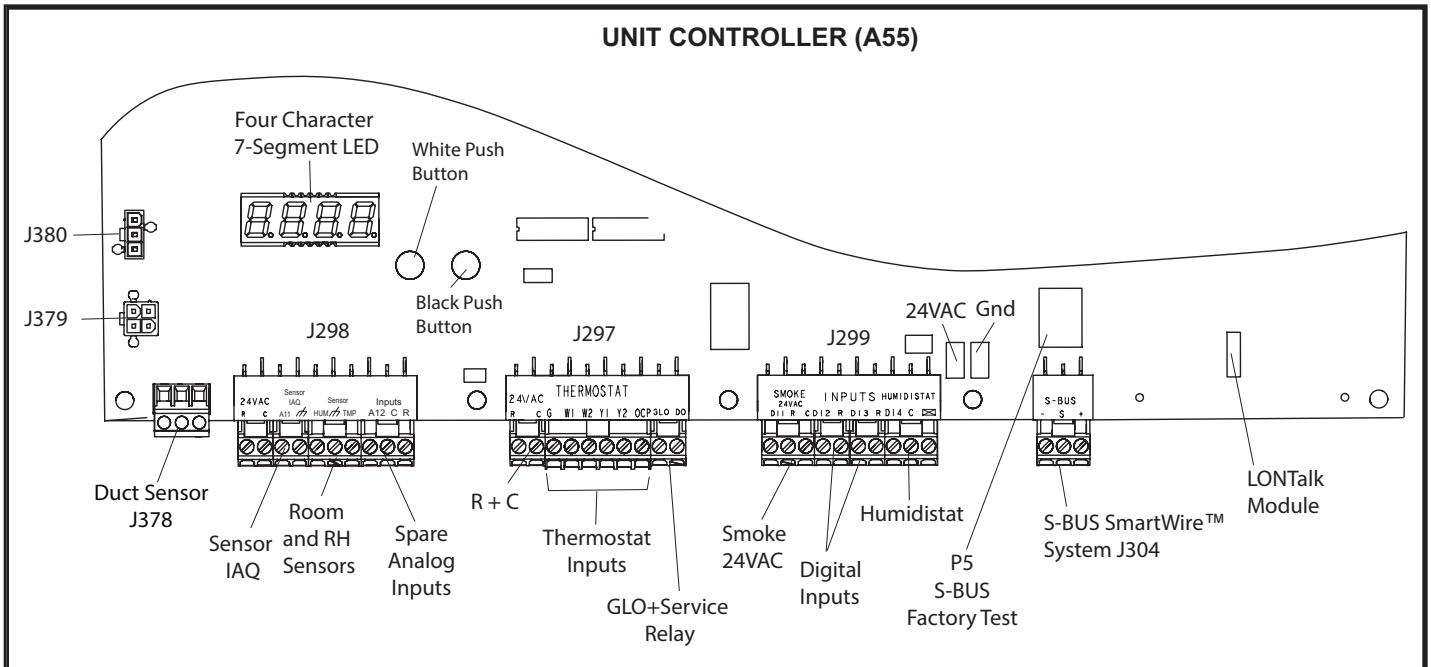
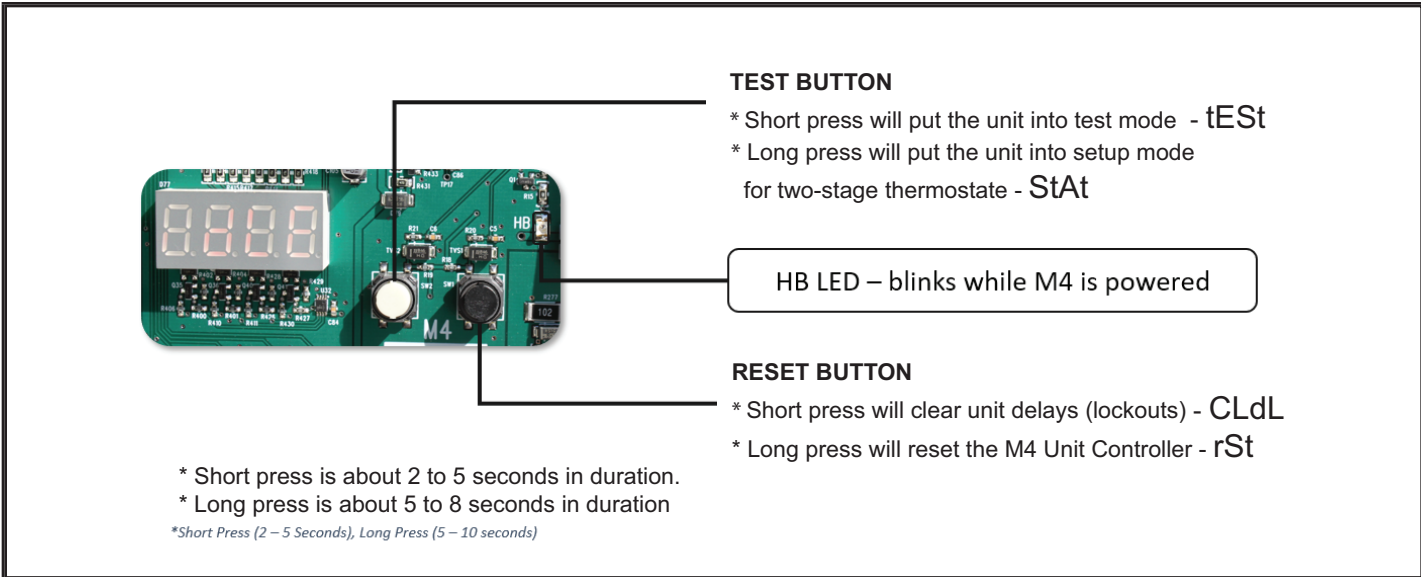


FIGURE 26



**FIGURE 27**

**TABLE 2**  
**UNIT CONTROLLER PUSHBUTTON CODES**

Code	Cause	Action
CLdL	Black Button: Short Press	Clear Delays
rSt	Black Button: Long Press	Reset
tEst	White Button: Short Press	TSTAT Test
StAt	White Button: Long Press (In Pre-Install state)	TSTAT Override
tEst	White Button: Long Press (NOT in Pre-Install State)	TSTAT Test

Short Press : 2 to 5 seconds.  
 Long Press : 5 to 8 seconds.

## Blower Operation

Units are equipped with variable speed, direct drive blowers. The supply CFM can be adjusted by changing the percentage of motor output using the Unit Controller settings. Measure the intake air CFM and adjust the RPM% to get design-specified supply air CFM. Refer to the Direct Drive Blower Start-Up section.

### IMPORTANT

Compressor two is the only component that must be checked to ensure proper phasing. Follow "COOLING START-UP" section of installation instructions to ensure proper compressor and blower operation.

The Unit Controller checks the incoming power during start-up. If the voltage or phase is incorrect, the Unit Controller will display an alarm and the unit will not start.

#### A-Blower Operation

Refer to the Unit Controller Setup Guide to energize blower. Use the mobile service app menu; see:

#### SERVICE > TEST

In both thermostat and zone control mode, the Unit Controller will stage the blower between low and high speed.

### WARNING

- 1- Make sure that unit is installed in accordance with the installation instructions and applicable codes.
- 2- Inspect all electrical wiring, both field and factory-installed, for loose connections. Tighten as required.
- 3- Check to ensure that refrigerant lines do not rub against the cabinet or against other refrigerant lines.
- 4- Check voltage at disconnect switch. Voltage must be within range listed on nameplate. If not, consult power company and have voltage condition corrected before starting unit.
- 5- Make sure filters are new and in place before start-up.

Initiate blower only (G) demand at thermostat according to instructions provided with thermostat. Unit will cycle on thermostat demand. The following steps apply to applications using a typical electro-mechanical thermostat.

- 1 - Blower operation is manually set at the thermostat subbase fan switch. With fan switch in ON position, blowers will operate continuously.
- 2 - With fan switch in AUTO position, the blowers will cycle with demand. Blowers and entire unit will be off when system switch is in OFF position.

**NOTE** - Blower operation mode can also be initiated by the mobile service app.

Direct-drive motor may not immediately stop when power is interrupted to the Unit Controller. Disconnect unit power before opening the blower compartment. The Controller's digital inputs must be used to shut down the blower. See Unit Controller manual for operation sequences.

#### B-Blower Access

The blower assembly is secured to a sliding frame which allows the blower assembly to be pulled out of the unit. See FIGURE 29.

- 1 - Loosen the reusable wire tie which secures the controls and high voltage blower wiring to the blower housing. Disconnect the pressure sensor low voltage wire harness.
- 2 - Remove and retain screws on either side (and on the front for direct drive) of sliding frame. Use the metal handle to pull frame toward outside of unit.
- 3 - Slide frame back into original position when finished servicing. Reattach the blower wiring in the previous location using the wire tie. Reconnect pressure sensor low voltage wire harness.
- 4 - Replace retained screws.

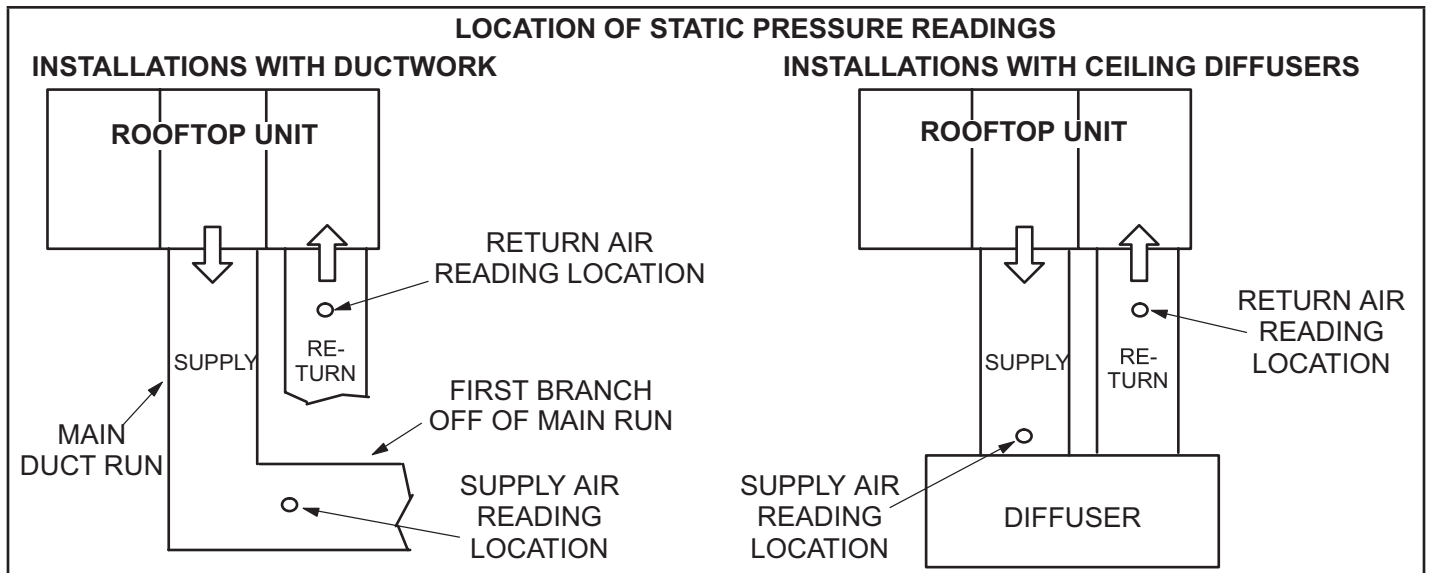


FIGURE 28

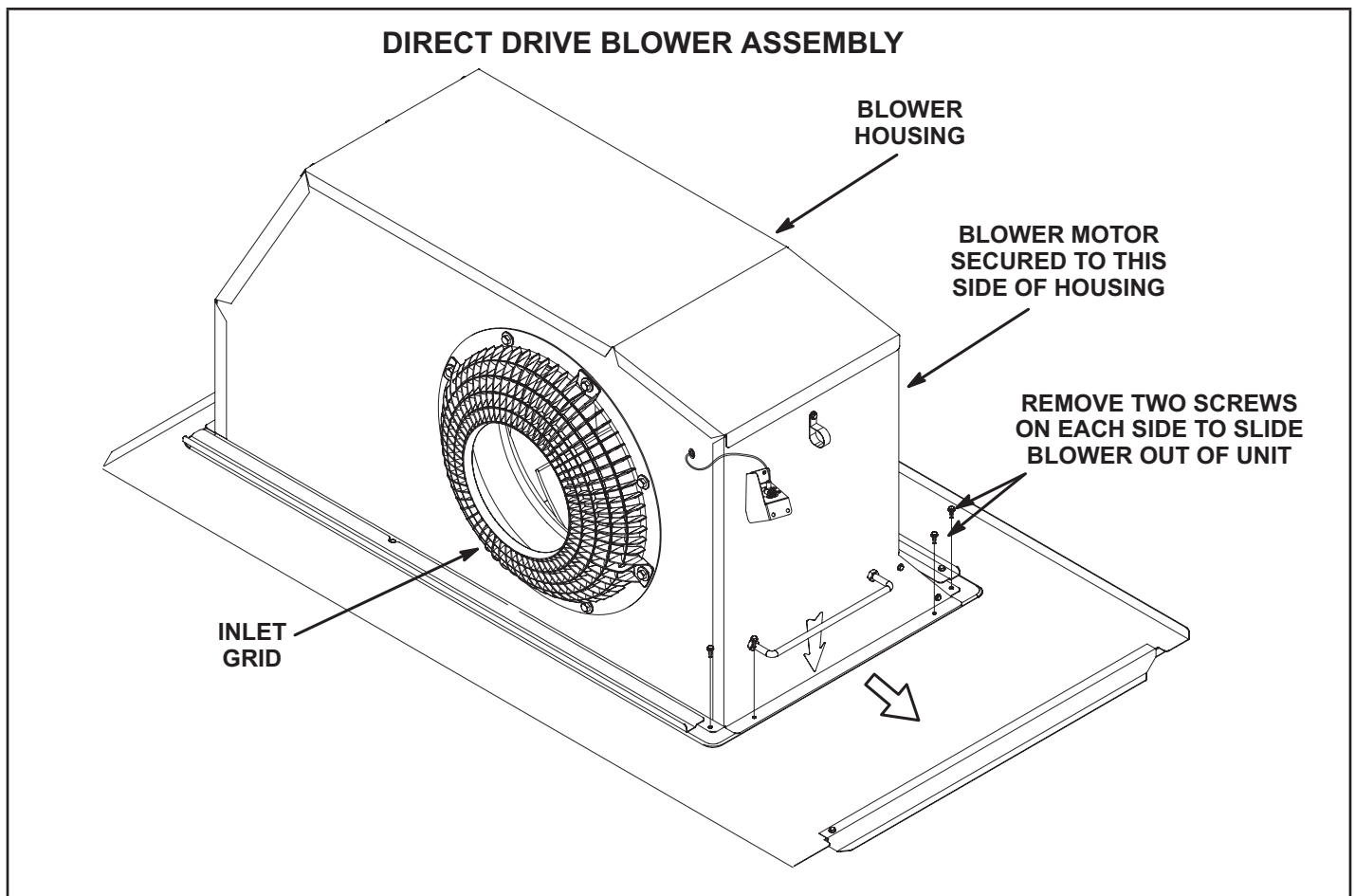


FIGURE 29

## Direct Drive Blower Start-Up

The supply CFM can be adjusted by changing the percentage of motor output using the Unit Controller settings. Refer to TABLE 3 for menu paths and default settings. Record any RPM% changes on the parameter settings label located on the inside of the compressor access panel.

### IMPORTANT

The BLOWER CALIBRATION process starts the in door blower at operational speeds and moves the economizer damper blades. Before starting this process, replace any access panels and close all unit doors except compressor compartment door.

Blower calibration is required only on units that are newly installed or if there is a change in the duct work or air filters after installation. Use the mobile service app to navigate to the SETUP>TEST & BALANCE>BLOWER menu. After the new CFM values are entered, select START CALIBRATION. The blower calibration status is displayed as a % complete. Upon successful completion, the mobile service app will display CALIBRATION SUCCESS and go back to the blower calibration screen.

*IMPORTANT - The default value for Cooling Low CFM is lower than a traditional single- or two-speed unit. If operating the unit with a 2- or 3-stage controller (2- or 3-stage thermostat, DDC controller, etc.), it is recommended to increase the Cooling Low CFM default value to a suitable level for part load cooling (typically 60% of full load CFM).*

**TABLE 3  
DIRECT DRIVE PARAMETER SETTINGS - 581102-01**

Parameter	Field Setting	Description
<b>NOTE - Any changes to Smoke CFM setting must be adjusted before the other CFM settings. Use SETTINGS &gt; RTU OPTIONS &gt; EDIT PARAMETERS = 12 for EBM, 6 for ECM</b>		
BLOWER SMOKE CFM	%	Percentage of RPM for blower smoke speed.
<b>SETUP &gt; TEST &amp; BALANCE &gt; BLOWER</b>		
BLOWER HEATING HIGH CFM	%	Percentage of RPM for blower heating high speed.
BLOWER HEATING LOW CFM	%	Percentage of RPM for blower heating low speed (P volt gas heat only).
BLOWER COOLING HIGH CFM	%	Percentage of RPM for blower cooling high speed.
BLOWER COOLING LOW CFM	%	Percentage of RPM for blower cooling low speed and vent speed for standard static blowers.
BLOWR VENTILATION CFM	%	Percentage of RPM for high static blower ventilation speed.
<b>SETUP &gt; TEST &amp; BALANCE &gt; DAMPER</b>		
BLOWER HIGH CFM DAMPER POS %	%	Minimum damper position for high speed blower operation. Default 0%.
BLOWER LOW CFM DAMPER PS %	%	Minimum damper position for low speed blower operation. Default 0%.
POWER EXHAUST DAMPER POS %	%	Minimum damper position for low power exhaust operation. Default 50%.
<b>SETTING &gt; RTU OPTIONS &gt; EDIT PARAMETERS = 216</b>		
POWER EXHAUST DEADBAND %	%	Deadband % for power exhaust operation. Default 10%.
<b>SETTINGS &gt; RTU OPTIONS &gt; EDIT PARAMETERS = 10 (Applies to Thermostat Mode ONLY)</b>		
FREE COOLING STAGE-UP DELAY	sec	Number of seconds to hold blower at low speed before switching to blower at high speed. Default 300 seconds.

**Installer** - Record any parameter changes under "Field Setting" column. Settings need to be recorded by installer for use when Unit Controller is replaced or reprogrammed.

## BLOWER DATA

**BLOWER TABLE INCLUDES RESISTANCE FOR BASE UNIT ONLY (NO HEAT SECTION) WITH DRY INDOOR COIL AND AIR FILTERS IN PLACE.**

FOR ALL UNITS ADD:

- 1- Wet indoor coil air resistance of selected unit.
  - 2- Any factory installed options air resistance (heat section, Economizer, etc.)
  - 3- Any field installed accessories air resistance (duct resistance, diffuser, etc.)
- See page 24 for wet coil and option/accessory air resistance data.  
See page 24 for minimum air volume required for use with optional electric heat.

**Maximum Static Pressure With Gas Heat - 2.0 in. w.g.**

**Minimum Air Volume Required For Different Gas Heat Sizes:**

Standard - 2150 cfm; Medium - 2250 cfm; High - 2600 cfm

Total Air Volume cfm	Total Static Pressure - in. w.g.													
	0.2		0.4		0.6		0.8		1.0		1.2		1.4	
	RPM	Watts	RPM	Watts	RPM	Watts	RPM	Watts	RPM	Watts	RPM	Watts	RPM	Watts
1750	644	137	740	235	796	302	833	343	873	373	996	558	1065	664
2000	675	165	768	260	821	330	861	386	960	507	1026	629	1094	753
2250	711	195	803	290	856	375	901	497	991	564	1058	703	1128	840
2500	764	241	852	335	904	439	951	568	1025	641	1097	789	1170	934
2750	847	316	901	399	946	543	1004	674	1074	746	1146	895	1220	1041
3000	944	426	980	511	1021	671	1074	803	1136	874	1205	1021	1276	1167
3250	1022	544	1057	640	1099	810	1149	942	1207	1012	1272	1156	1338	1304
3500	1092	666	1131	770	1174	948	1225	1081	1281	1151	1342	1297	1402	1451
3750	1161	780	1202	892	1248	1079	1298	1217	1353	1291	1409	1445	1463	1609
4000	1230	888	1273	1010	1319	1212	1369	1362	1421	1441	1471	1608	1518	1784
4250	1299	1006	1342	1140	1388	1362	1436	1526	1483	1612	1528	1790	1571	1975
4500	1366	1142	1409	1289	1454	1532	1498	1708	1542	1798	1583	1984	1623	2172
4750	1432	1295	1474	1457	1516	1719	1558	1903	1598	1997	1637	2187	1674	2377
5000	1496	1471	1537	1645	1577	1921	1616	2110	1654	2205	1690	2396	1726	2586
5250	1560	1667	1598	1849	1636	2132	1673	2324	1709	2419	1744	2609	1779	2796
5500	1623	1878	1659	2064	1695	2349	1731	2539	1765	2634	---	---	---	---
5750	1686	2097	1720	2284	1755	2567	---	---	---	---	---	---	---	---
6000	1748	2316	1781	2502	---	---	---	---	---	---	---	---	---	---

Total Air Volume cfm	Total Static Pressure - in. w.g.											
	1.6		1.8		2.0		2.2		2.4		2.6	
	RPM	Watts	RPM	Watts	RPM	Watts	RPM	Watts	RPM	Watts	RPM	Watts
1750	1134	775	1203	896	1275	1025	1356	1149	1422	1287	1470	1439
2000	1162	878	1231	1007	1302	1139	1379	1268	1440	1411	1486	1570
2250	1198	975	1268	1111	1338	1250	1409	1388	1464	1542	1507	1711
2500	1243	1075	1313	1217	1380	1365	1442	1517	1491	1685	1533	1860
2750	1293	1186	1361	1336	1423	1494	1477	1661	1520	1839	1561	2016
3000	1346	1317	1410	1474	1466	1642	1514	1818	1554	2000	1594	2180
3250	1402	1460	1460	1627	1511	1803	1553	1986	1591	2172	1631	2352
3500	1459	1616	1509	1793	1555	1976	1594	2165	1631	2352	1671	2531
3750	1512	1785	1557	1970	1599	2159	1636	2350	1673	2536	1713	2714
4000	1562	1969	1604	2157	1643	2347	1680	2538	1717	2722	1756	2896
4250	1611	2163	1650	2352	1688	2541	1724	2729	1762	2908	-	-
4500	1661	2362	1698	2552	1734	2739	1770	2922	-	-	-	-
4750	1710	2567	1746	2754	-	-	-	-	-	-	-	-
5000	1761	2774	-	-	-	-	-	-	-	-	-	-
5250	-	-	-	-	-	-	-	-	-	-	-	-

# BLOWER DATA

FACTORY INSTALLED OPTIONS/FIELD INSTALLED ACCESSORY AIR RESISTANCE - in. w.g.

Air Volume cfm	Wet Indoor Coil		Reheat Coil	Gas Heat Exchanger			Electric Heat (LHT)	Econo-mizer	Filters			Return Air Adaptor Plate
	078, 092, 102, 120	152		Standard Heat	Medium Heat	High Heat			MERV 8	MERV 13	MERV 16	
1750	0.04	0.04	0.02	0.06	0.02	0.02	0.03	0.05	0.01	0.03	0.06	0.00
2000	0.05	0.05	0.02	0.07	0.05	0.06	0.03	0.06	0.01	0.03	0.08	0.00
2250	0.06	0.06	0.02	0.07	0.07	0.08	0.04	0.08	0.01	0.04	0.09	0.00
2500	0.07	0.07	0.03	0.09	0.10	0.11	0.04	0.11	0.01	0.05	0.10	0.00
2750	0.08	0.08	0.03	0.09	0.11	0.12	0.05	0.12	0.02	0.05	0.11	0.00
3000	0.10	0.09	0.03	0.11	0.12	0.13	0.06	0.13	0.02	0.06	0.12	0.02
3250	0.11	0.10	0.04	0.12	0.15	0.16	0.06	0.15	0.02	0.06	0.13	0.02
3500	0.12	0.11	0.04	0.12	0.16	0.17	0.09	0.15	0.03	0.07	0.15	0.04
3750	0.14	0.13	0.05	0.14	0.19	0.20	0.09	0.15	0.03	0.08	0.16	0.07
4000	0.15	0.14	0.05	0.14	0.21	0.22	0.09	0.19	0.04	0.08	0.17	0.09
4250	0.17	0.15	0.06	0.14	0.24	0.28	0.13	0.19	0.04	0.09	0.19	0.11
4500	0.19	0.17	0.07	0.15	0.26	0.32	0.14	0.22	0.04	0.09	0.20	0.12
4750	0.20	0.18	0.07	0.16	0.29	0.37	0.17	0.25	0.05	0.10	0.21	0.16
5000	0.22	0.20	0.08	0.16	0.34	0.43	0.20	0.29	0.06	0.10	0.23	0.18
5250	0.24	0.22	0.08	0.16	0.37	0.47	0.22	0.32	0.06	0.11	0.24	0.19
5500	0.25	0.23	0.09	0.18	0.44	0.54	0.25	0.34	0.07	0.12	0.25	0.22
5750	0.27	0.25	0.10	0.19	0.49	0.59	0.31	0.45	0.07	0.12	0.27	0.25
6000	0.29	0.27	0.10	0.20	0.54	0.64	0.33	0.52	0.08	0.13	0.28	0.27

## MINIMUM AIR VOLUME REQUIRED FOR USE WITH OPTIONAL ELECTRIC HEAT

Electric Heat kW	Minimum cfm
7.5	1750
15	2250
22.5	2250
30	2750
45	2750
60	3500

## Refrigerant Leak Detection System

### A-System Test

- 1 - Initiate Refrigerant Leak Detection System Test by using the following mobile service app menu path:

**RTU MENU > COMPONENT TEST > LEAK DETECTION > START TEST**

- 2 - Ensure that indoor blower, outdoor fan, and combustion air blower (LDT only) are energized.

## Cooling Start-Up

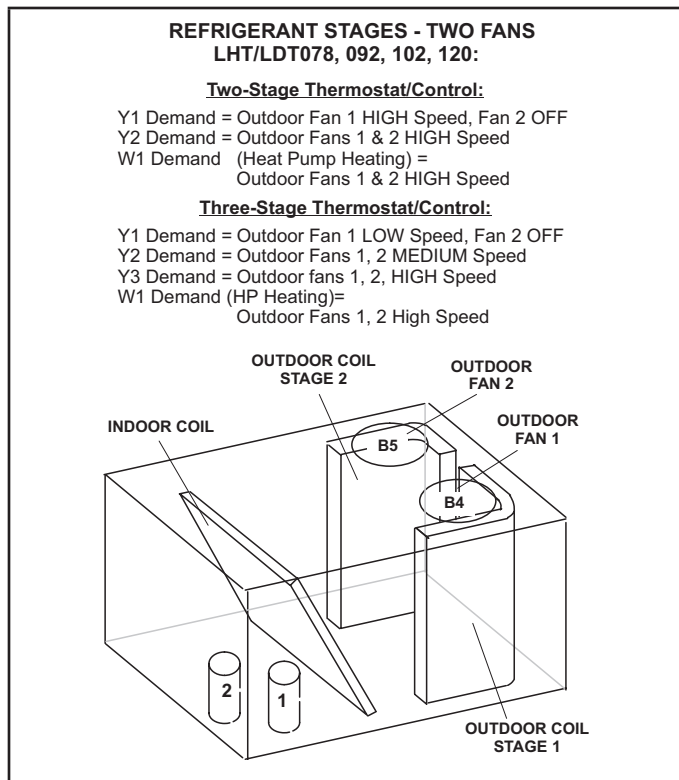
**IMPORTANT** - The crankcase heater must be energized for 24 hours before attempting to start compressor. Set thermostat so there is no demand to prevent compressors from cycling. Apply power to unit.

### A-Start-Up

- 1 - Initiate full load cooling operation using the following mobile service app menu path:

**RTU MENU > SERVICE > COMPONENT TEST > COOLING > COOLING STAGE 3**

- 2 - Refer to Cooling Operation section for cooling start-up.
- 3 - Units have two refrigerant circuits. See FIGURE 30 or FIGURE 31.
- 4 - Each refrigerant circuit is charged with R454B refrigerant. See unit rating plate for correct amount of charge.
- 5 - Refer to Refrigerant Check and Charge section for proper method to check refrigerant charge.



**FIGURE 30**

## REFRIGERANT STAGES - FOUR FANS

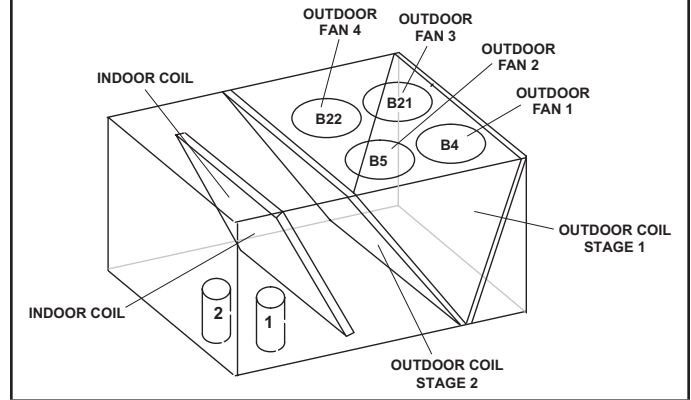
LHT/LDT152H:

### Two-Stage Thermostat/Control:

Y1 Demand = Outdoor Fans 1 & 3, HIGH Speed, 2 & 4 OFF  
Y2 Demand = Outdoor Fans 1, 2, 3, & 4 HIGH Speed  
W1 Demand (Heat Pump Heating) =  
Outdoor Fans 1, 2, 3, & 4 HIGH Speed

### Three-Stage Thermostat/Control:

Y1 Demand = Outdoor Fans 1 & 3, LOW Speed  
Y2 Demand = Outdoor Fans 1, 2, 3, & 4 MEDIUM Speed  
Y3 Demand = Outdoor Fans 1, 2, 3, & 4 HIGH Speed  
W1 Demand (HP Heating)=  
Outdoor Fans 1, 2, 3, & 4 HIGH Speed



**FIGURE 31**

## B-R454B Refrigerant

Units charged with R454B refrigerant operate at lower pressures than R410A. The expansion valve and liquid line dryer provided with the unit are approved for use with R454B.

R454B refrigerant is stored in a gray cylinder.

## CAUTION

Mineral oils are not compatible with R454B. If oil must be added, it must be a polyol ester oil.

Manifold gauge sets used with systems charged with R454B refrigerant must be capable of handling various system operating pressures. The gauges should be rated for use with pressures of 0-800 on the high side and a low side of 30" vacuum to 250 psi with dampened speed to 500 psi. Gauge hoses must be rated for use at up to 800 psi of pressure with a 4000 psi burst rating.

Refrigerant Charge R-454B			
Unit	Stage	M <sub>c</sub> (lbs)	M <sub>c</sub> (kg)
LHT/LDT 078	Stage 1	11.50	5.22
	Stage 2	11.00	4.99
LHT/LDT 092	Stage 1	11.00	4.99
	Stage 2	11.25	5.10
LHT/LDT 102	Stage 1	10.85	4.92
	Stage 2	11.25	5.10
LHT/LDT 120	Stage 1	10.69	4.85
	Stage 2	10.63	4.82
LHT/LDT 152	Stage 1	15.00	6.80
	Stage 2	12.75	5.78
LHT/LDT078 w/ Humiditrol	Stage 1	13.00	5.90
	Stage 2	11.00	4.99
LHT/LDT092 w/ Humiditrol	Stage 1	13.75	6.24
	Stage 2	11.25	5.10
LHT/LDT102 w/ Humiditrol	Stage 1	15.50	7.03
	Stage 2	11.25	5.10
LHT/LDT120 w/ Humiditrol	Stage 1	13.50	6.12
	Stage 2	10.63	4.82
LHT/LDT152 w/ Humiditrol	Stage 1	16.00	7.26
	Stage 2	12.75	5.78

In addition to conventional charging procedures, the following requirements shall be followed.

- Ensure that contamination of different refrigerants does not occur when using charging equipment. Hoses or lines shall be as short as possible to minimize the amount of refrigerant contained in them.
- Cylinders shall be kept in an appropriate position according to the instructions.
- Ensure that the unit is earth grounded prior to charging the system with refrigerant.
- Label the system when charging is complete (if not already).
- Extreme care shall be taken not to overfill the unit.

Prior to recharging the system, it shall be pressure-tested with the appropriate purging gas. The system shall be leak-tested on completion of charging but prior to commissioning. A follow up leak test shall be carried out prior to leaving the site.

- When removing refrigerant from a system, either for servicing or decommissioning, it is recommended good practice that all refrigerants are removed safely.
- When transferring refrigerant into cylinders, ensure that only appropriate refrigerant recovery cylinders are employed. Ensure that the correct number of cylinders for holding the total system charge is available. All cylinders to be used are designated for the recovered refrigerant and labelled for that refrigerant (i. e. special cylinders for the recovery of

refrigerant). Cylinders shall be complete with pressure-relief valve and associated shut-off valves in good working order. Empty recovery cylinders are evacuated and, if possible, cooled before recovery.

- The recovery equipment shall be in good working order with a set of instructions concerning the equipment that is at hand and shall be suitable for the recovery of all appropriate refrigerants including, when applicable, flammable refrigerants. In addition, a set of calibrated weighing scales shall be available and in good working order. Hoses shall be complete with leak-free disconnect couplings and in good condition. Before using the recovery machine, check that it is in satisfactory working order, has been properly maintained and that any associated electrical components are sealed to prevent ignition in the event of a refrigerant release. Consult manufacturer if in doubt.
- The recovered refrigerant shall be returned to the refrigerant supplier in the correct recovery cylinder, and the relevant waste transfer note arranged. Do not mix refrigerants in recovery units and especially
- If compressors or compressor oils are to be removed, ensure that they have been evacuated to an acceptable level to make certain that flammable refrigerant does not remain within the lubricant. The evacuation process shall be carried out prior to returning the compressor to the suppliers. Only electric heating to the compressor body shall be employed to accelerate this process. When oil is drained from a system, it shall be carried out safely.

**NOTE** - System charging is not recommended below 60°F (15°C). In temperatures below 60°F (15°C), the charge must be weighed into the system.

If weighing facilities are not available, or to check the charge, use the following procedure:

- 1 - Make sure outdoor coil is clean. Attach gauge manifolds and operate unit at full CFM in cooling mode with economizer disabled until system stabilizes (approximately five minutes). Make sure all outdoor air dampers are closed.
- 2 - Compare the normal operating pressures to the pressures obtained from the gauges. Check unit components if there are significant differences.
- 3 - Measure the outdoor ambient temperature and the suction pressure. Refer to the charging curve to determine a target liquid temperature.

**NOTE** - Pressures are listed for sea level applications.

- 4 - Use the same thermometer to accurately measure the liquid temperature (in the outdoor section).
- If measured liquid temperature is higher than the target liquid temperature, add refrigerant to the system.

- If measured liquid temperature is lower than the target liquid temperature, recover some refrigerant from the system..
- 5 - Add or remove charge in increments. Allow the system to stabilize each time refrigerant is added or removed.
  - 6 - Continue the process until measured liquid temperature agrees with the target liquid temperature. Do not go below the target liquid temperature when adjusting charge. Note that suction pressure can change as charge is adjusted.
  - 7 - Example: At 95°F outdoor ambient and a measured suction pressure of 130psig, the target liquid temperature is 97°F. For a measured liquid temperature of 106°F, add charge in increments until measured liquid temperature agrees with the target liquid temperature.

**TABLE 4 581257-01  
LHT/LDT078**

OD Coil Entering Air Temp	Circuit 1			Circuit 2		
	Disch. ± 10 psig	Suct. ± 5 psig	Appr. Temp ±1°F	Disch. ± 10 psig	Suct. ± 5 psig	Appr. Temp ± 1°F
65°F	238	127	2	220	131	5
75°F	274	130	2	254	135	3
85°F	314	131	2	292	137	1
95°F	357	132	2	333	138	1
100°F	404	133	3	376	140	1
115°F	452	136	2	431	143	2

**TABLE 5 581434-01  
LHT/LDT078 w/ Reheat**

OD Coil Entering Air Temp	Circuit 1			Circuit 2		
	Disch. ± 10 psig	Suct. ± 5 psig	Appr. Temp ±1°F	Disch. ± 10 psig	Suct. ± 5 psig	Appr. Temp ± 1°F
65°F	243	125	2	220	131	5
75°F	276	126	2	254	135	3
85°F	317	128	2	292	137	2
95°F	361	128	2	333	138	2
100°F	406	131	2	376	140	2
115°F	466	132	2	431	143	2

**TABLE 6 581258-01  
LHT/LDT092**

OD Coil Entering Temp.	CIRCUIT 1			CIRCUIT 2		
	Disch. ± 10 psig	Suct. ± 5 psig	Appr. Temp±1°F	Disch. ± 10 psig	Suct. ± 5 psig	Appr. Temp±1°F
65 °F	232	120	4	235	125	7
75 °F	269	125	2	271	129	6
85 °F	308	127	2	311	131	3
95 °F	352	130	3	356	133	4
105 °F	398	132	3	401	136	4
115 °F	450	134	4	453	139	5

**TABLE 7 581435-01  
LHT/LDT092 w/ Reheat**

OD Coil Entering Temp.	CIRCUIT 1			CIRCUIT 2		
	Disch. ± 10 psig	Suct. ± 5 psig	Appr. Temp±1°F	Disch. ± 10 psig	Suct. ± 5 psig	Appr. Temp±1°F
65 °F	241	126	2	235	125	7
75 °F	279	127	2	271	129	6
85 °F	321	129	2	311	131	3
95 °F	371	132	3	356	133	4
105 °F	419	133	3	401	136	4
115 °F	472	135	3	453	139	5

**TABLE 8 581259-01  
LHT/LDT102**

OD Coil Entering Temp.	CIRCUIT 1			CIRCUIT 2		
	Disch. ± 10 psig	Suct. ± 5 psig	Appr. Temp±1°F	Disch. ± 10 psig	Suct. ± 5 psig	Appr. Temp±1°F
65 °F	233	122	5	246	121	8
75 °F	271	127	3	282	125	8
85 °F	309	127	3	323	127	4
95 °F	351	129	3	365	129	4
105 °F	398	130	3	413	132	5
115 °F	447	132	4	464	135	6

**TABLE 9 581436-01  
LHT/LDT102 w/ Reheat**

OD Coil Entering Temp.	CIRCUIT 1			CIRCUIT 2		
	Disch. ± 10 psig	Suct. ± 5 psig	Appr. Temp±1°F	Disch. ± 10 psig	Suct. ± 5 psig	Appr. Temp±1°F
65 °F	244	125	2	246	121	8
75 °F	287	126	3	282	125	8
85 °F	324	128	2	323	127	4
95 °F	378	131	3	365	129	4
105 °F	426	133	3	413	132	5
115 °F	477	134	2	464	135	6

**TABLE 10 581260-01  
LHT/LDT120**

OD Coil Entering Temp.	CIRCUIT 1			CIRCUIT 2		
	Disch. ± 10 psig	Suct. ± 5 psig	Appr. Temp±1°F	Disch. ± 10 psig	Suct. ± 5 psig	Appr. Temp±1°F
65 °F	247.2	121.2	9	255.6	122	12
75 °F	284.3	124.7	8	293.2	125.2	8
85 °F	325.1	129.6	6	335.1	127.5	8
95 °F	368.1	132.7	6	376.4	130.6	7
105 °F	416	135.5	7	426.6	134.4	8
115 °F	464.2	137.9	8	473.1	137.2	9

**TABLE 11 581437-01**  
**LHT/LDT120 w/ Reheat**

OD Coil Entering Temp.	CIRCUIT 1			CIRCUIT 2		
	Disch. ± 10 psig	Suct. ± 5 psig	Appr. Temp±1°F	Disch. ± 10 psig	Suct. ± 5 psig	Appr. Temp±1°F
65 °F	218	121	2	256	122	12
75 °F	220	122	2	293	125	8
85 °F	239	122	2	335	128	8
95 °F	379	123	2	376	131	7
105 °F	311	126	2	427	134	8
115 °F	346	128	2	473	137	9

**TABLE 12 581261-01**  
**LHT/LDT152**

OD Coil Entering Temp.	CIRCUIT 1			CIRCUIT 2		
	Disch. ± 10 psig	Suct. ± 5 psig	Appr. Temp±1°F	Disch. ± 10 psig	Suct. ± 5 psig	Appr. Temp±1°F
65 °F	239	122	9	258	122	10
75 °F	276	125	8	296	124	4
85 °F	318	127	2	336	126	4
95 °F	363	132	3	389	129	5
105 °F	412	133	4	425	129	5
115 °F	467	135	4	475	131	5

**TABLE 13 581438-01**  
**LHT/LDT152 w/ Reheat**

OD Coil Entering Temp.	CIRCUIT 1			CIRCUIT 2		
	Disch. ± 10 psig	Suct. ± 5 psig	Appr. Temp±1°F	Disch. ± 10 psig	Suct. ± 5 psig	Appr. Temp±1°F
65 °F	246	124	11	258	122	10
75 °F	284	126	3	296	124	4
85 °F	325	126	2	336	126	4
95 °F	372	130	2	389	129	5
105 °F	418	133	2	425	129	5
115 °F	472	136	2	475	131	5

### Charge Verification - Approach Method - AHRI Testing

- 1 - Using the same thermometer, compare liquid temperature to outdoor ambient temperature. Approach Temperature = Liquid temperature (at liquid line close to pressure tap) minus ambient temperature.
- 2 - Refer to TABLE 4 through TABLE 12 for approach temperatures. An approach temperature greater than value shown indicates an undercharge. An approach temperature less than value shown indicates an overcharge.
- 3 - The approach method is not valid for grossly over or undercharged systems. Use TABLE 4 through TABLE 12 as a guide for typical operating pressures.

### F-Compressor Controls

See unit wiring diagram to determine which controls are used on each unit.

- 1 - High Pressure Switch (S4, S7)

The compressor circuit is protected by a high pressure switch which opens at 640 psig + 10 psig (4413 kPa + 70 kPa) and automatically resets at 475 psig + 20 psig (3275kPa + 138 kPa).

- 2 - Low Pressure Switch (S87, S88)

The compressor circuit is protected by a loss of charge switch. Switch opens at 25 psig + 5 psig (172 + 34 kPa) and automatically resets at 40 psig + 5 psig (276 kPa + 34 kPa).

- 3 - Crankcase Heater (HR1, HR2)

Compressors have belly band compressor oil heaters which must be on 24 hours before running compressors. Energize by setting thermostat so that there is no cooling demand, to prevent compressor from cycling, and apply power to unit.

- 4 - Diagnostics Sensors (RT46-RT49)

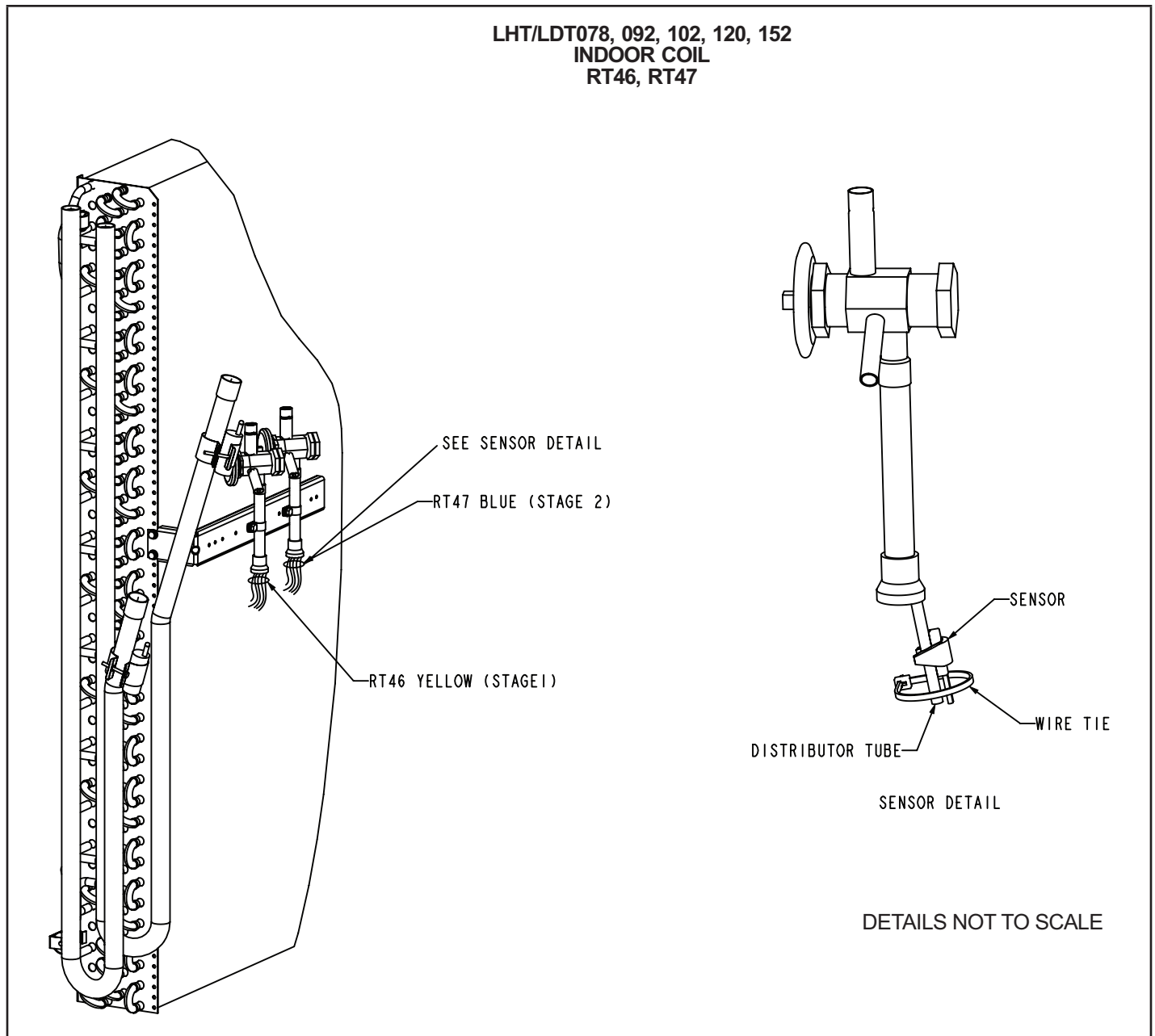
Four thermistors are located on specific points in the refrigeration circuit. The thermistors provide constant temperature feedback to the Unit Controller to protect the compressor. Thermistors take the place of the freezestat and low ambient pressure switch.

## Diagnostic Sensors

Units are equipped with four factory-installed thermistors (RT46 - RT49) located on different points on the refrigerant circuit.

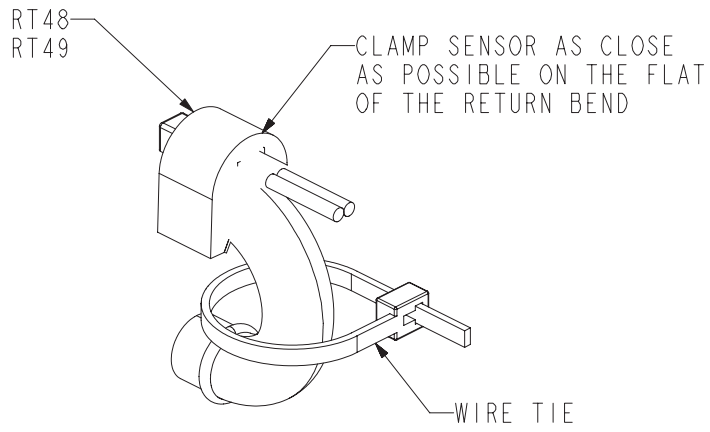
The thermistors provide the Unit Controller with constant temperature readings of four specific locations on the refrigeration circuit. These temperatures are used as feedback in certain modes of unit operation. In addition, the Unit Controller uses these temperatures to initiate alarms such as loss of outdoor or indoor coil airflow.

Each thermistor must be specifically placed for proper unit operation and to initiate valid alarms. See FIGURE 32 and FIGURE 33 for proper locations.

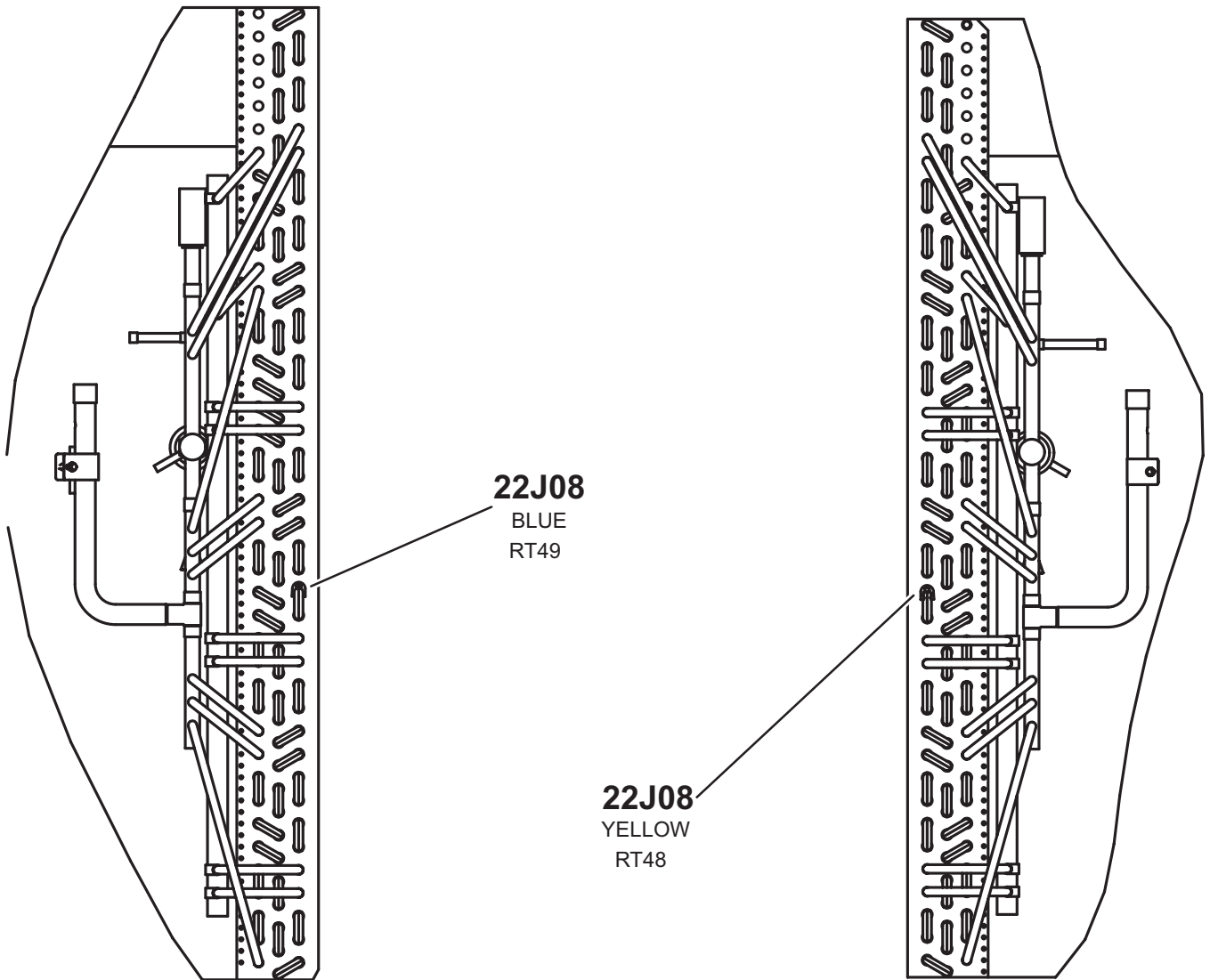


**FIGURE 32**

LHT/LDT078, 092, 102, 120, 152  
OUTDOOR COIL  
RT48, RT49



SENSOR DETAIL



STAGE 2

DETAILS NOT TO SCALE

FIGURE 33

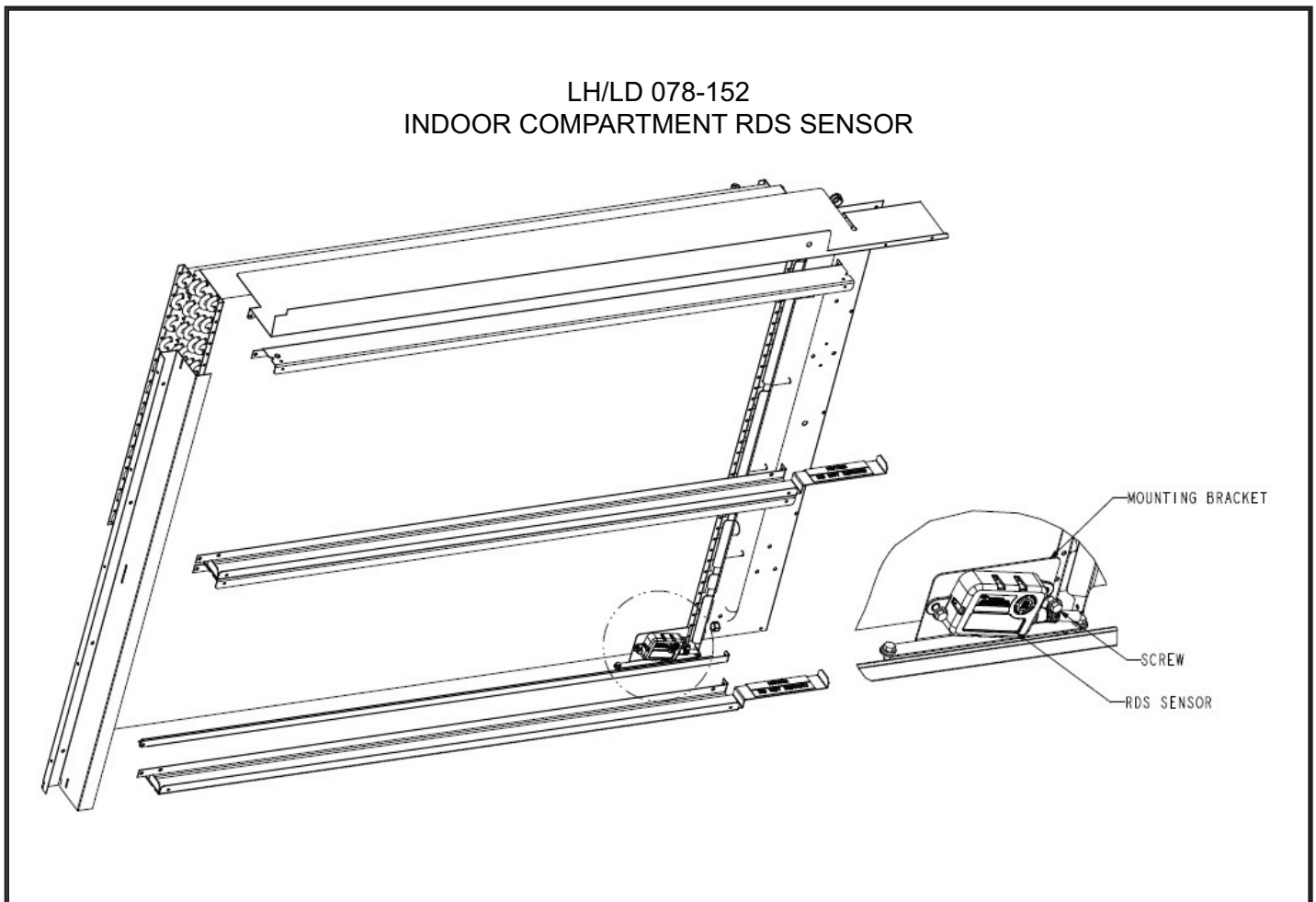
## RDS Sensors

Units are equipped with factory-installed RDS Sensors located on different points on the unit. The RDS sensors provide the Unit Controller with continuous readings for leaked refrigerant concentration levels and sensor health status (Good or Fault). These readings are used to modify unit operation to disperse the leaked refrigerant and to remove possible ignition sources. In addition, the Unit Controller uses these readings to initiate alarms to alert the operator of a refrigerant leak or faulty sensor(s).

Each sensor must be specifically placed for proper unit operation and to initiate valid alarms. To identify sensor locations see TABLE 14 and FIGURE 34.

**TABLE 14**  
**RDS Sensor Figures**

Model	Qty.	Type	Figure
LHT/LDT078-152	1 sensor	INDOOR SENSOR	FIGURE 34



**FIGURE 34**

## Gas Heat Start-Up (LDT)

FOR YOUR SAFETY, READ BEFORE LIGHTING.

### ⚠ WARNING



Electric shock hazard. Can cause injury or death. Do not use this unit if any part has been under water. Immediately call a qualified service technician to inspect the unit and to replace any part of the control system and any gas control which has been under water.

### ⚠ WARNING



Danger of explosion. Can cause injury or product or property damage. If overheating occurs or if gas supply fails to shut off, shut off the manual gas valve to the appliance before shutting off electrical supply.

### ⚠ WARNING



Electric shock hazard. Can cause injury or death. Before attempting to perform any service or maintenance, turn the electrical power to unit OFF at disconnect switch(es). Unit may have multiple power supplies.

### ⚠ WARNING

#### SMOKE POTENTIAL

The heat exchanger in this unit could be a source of smoke on initial firing. Take precautions with respect to building occupants and property. Vent initial supply air outside when possible.

BEFORE LIGHTING smell all around the appliance area for gas. Be sure to smell next to the floor because some gas is heavier than air and will settle on the floor.

Use only your hand to push in or turn the gas control knob. Never use tools. If the knob will not push in or turn by hand, do not try to repair it, call a qualified service technician. Force or attempted repair may result in a fire or explosion.

### ⚠ WARNING



Danger of explosion. Can cause injury or death. Do not attempt to light manually. Unit has a direct spark ignition system.

This unit is equipped with an automatic spark ignition system. There is no pilot. In case of a safety shutdown, move thermostat switch to **OFF** and return the thermostat switch to **HEAT** to reset ignition control.

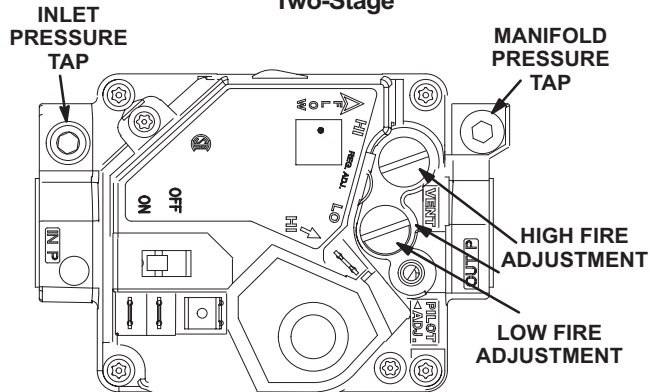
## A-Placing Unit In Operation

### ⚠ WARNING



Danger of explosion and fire. Can cause injury or product or property damage. You must follow these instructions exactly.

#### WHITE RODGERS 36H54 GAS VALVE Two-Stage



GAS VALVE SWITCH SHOWN IN ON POSITION.

FIGURE 35

#### WHITE RODGERS 36H27 GAS VALVE MODULATING

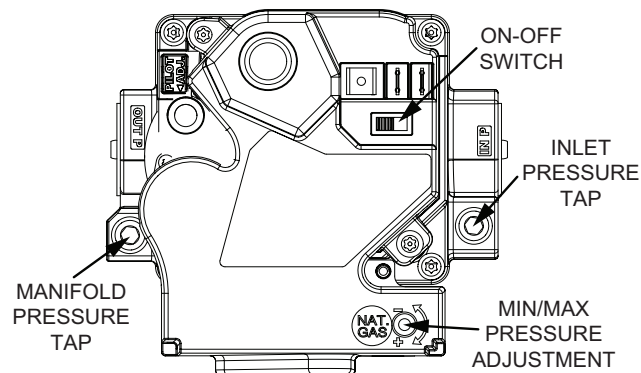


FIGURE 36

- 1 - Set balance point setpoint above the outdoor ambient temperature to disable heat pump operation.
- 2 - Set thermostat to lowest setting.
- 3 - Turn off all electrical power to appliance.
- 4 - This appliance is equipped with an ignition device which automatically lights the burner. Do not try to light the burner by hand.
- 5 - Open or remove the heat section access panel.
- 6 - Turn gas valve switch to **OFF**. See FIGURE 35 and FIGURE 36.
- 7 - Wait five (5) minutes to clear out any gas. If you then smell gas, **STOP!** Immediately call your gas supplier from a neighbor's phone. Follow the gas supplier's instructions. If you do not smell gas, go to the next step.

- 8 - Turn gas valve switch to **ON**. See FIGURE 35 and FIGURE 36.
- 9 - Close or replace the heat section access panel.
- 10 - Turn on all electrical power to appliance.
- 11 - Set thermostat to desired setting.

**NOTE** - When unit is initially started, steps 1 through 9 may need to be repeated to purge air from gas line.

- 12 - The ignition sequence will start. If the appliance does not light the first time (gas line not fully purged), it will attempt up to two more ignitions before locking out.
- 13 - If lockout occurs, repeat steps 1 through 10.
- 14 - If the appliance will not operate, follow the instructions "Turning Off Gas to Appliance" and call your service technician or gas supplier.

#### **Turning Off Gas to Unit**

- 1 - If using an electromechanical thermostat, set to the lowest setting.
- 2 - Before performing any service, turn off all electrical power to the appliance.
- 3 - Open or remove the heat section access panel.
- 4 - Turn gas valve switch to **OFF**. On Honeywell VR8305 gas valves, turn the knob on the gas valve clockwise to **OFF**. Do not force.
- 5 - Close or replace the heat section access panel.

 <b>WARNING</b>	
	Danger of explosion. Can cause injury or death. Do not attempt to light manually. Unit has a direct spark ignition system.

## Gas Heating Operation

### A-Heating Sequence of Operation

The gas heating sequence of operation contains 3 distinct phases: ignition, heating demand, and termination.

#### Ignition – Two-Stage and Modulating

- 1 - Thermostat initiates heating demand (W1).
- 2 - CORE transmits W1 demand signal to the Direct Spark Ignition (DSI) control. For Modulating systems, CORE transmits an additional signal, Modulating Gas Valve (MGV) Position, to the DSI control which passes through to the MGv.
- 3 - DSI control activates Combustion Air Inducer (CAI) at low speed.
- 4 - CAI pressure switch proves inducer operation before DSI control opens gas valve.
- 5 - After a 30 second pre-purge time, DSI control energizes the spark ignitor and opens the gas valve to Low Fire (Two-Stage) or minimum position (Modulating).
- 6 - The spark then ignites the gas, and flame is verified by flame sensor.

**NOTE** - If flame is not detected, the DSI control will close the gas valve and repeat steps 4 and 5 two more times.

- 7 - After Gas Blower On Delay expires, CORE starts indoor blower operation.

#### Heating Demand – Two-Stage

- 1 - CORE operates indoor blower at the Blower Heating High CFM Setpoint (refer to TABLE 3).
- 2 - When thermostat initiates W2 demand, CORE transmits W2 signal to DSI control.
- 3 - DSI control opens the gas valve to High Fire and changes CAI speed from low to high.

#### Heating Demand – Modulating

- 1 - CORE operates indoor blower at Blower Heating Low CFM setpoint (refer to TABLE 3).
- 2 - MGv Position is consistently updated by the CORE during heating demand.
  - a. CORE monitors the Discharge Air Temperature (DAT) sensor and compares its value to the setpoint.
  - b. CORE calculates a new MGv Position.
  - c. CORE transmits new MGv Position to MGv which responds accordingly.
  - d. Steps a) thru c) are repeated until heating demand has been satisfied.
- 3 - Increasing MGv Position (minimum, moving toward maximum).
  - a. When CORE increases the MGv Position above programmed value, CORE outputs W2 signal to the DSI control.
  - b. DSI control changes CAI speed from low to high.
  - c. CORE changes indoor blower operation to Blower Heating High CFM setpoint (refer to TABLE 3).

- 4 - Decreasing MGv Position (maximum, moving toward minimum).
  - a. When CORE decreases MGv Position to minimum and CORE holds MGv in minimum position for preset time period, CORE removes W2 signal to DSI control.
  - b. DSI control changes CAI speed from high to low.
  - c. CORE changes indoor blower operation to Blower Heating Low CFM setpoint (refer to TABLE 3).

#### Extinguishment – Two-Stage and Modulating

- 1 - When thermostat demand is satisfied, heating demands (W1, W2) are removed from CORE.
- 2 - CORE removes any active demand signals (W1, W2) to DSI control. For Modulating systems, the CORE removes the MGv Position signal too.
- 3 - DSI control closes the gas valve.
- 4 - DSI control maintains CAI operation for post purge period (45 seconds), then shuts off CAI.
- 5 - CORE maintains indoor blower operation until Gas Blower Off Delay expires, then CORE shuts off the indoor blower.

#### B-Ignition Control Diagnostic LEDs

The table below refers to several components. The components and wiring diagram key numbers are: DSI Control Board (A3); Gas Valve (GV1 or GV4); Primary Limit Switch (S10); Combustion Air Blower Proofing Switch (S18); Rollout Switch (S47). Refer to the unit wiring diagram for further details.

**TABLE 15**  
**IGNITION CONTROL HEARTBEAT LED STATUS**

LED Flashes	Indicates
Slow Flash	Normal Operation – No call for heat
Fast Flash	Normal Operation - call for heat
Steady Off	Internal control board fault or no power
Steady On	Control board failure
1 Flash	Rollout Switch open
2 Flashes	Limit Switch open or opened multiple times during one heating demand
3 Flashes	Pressure Switch open with CAI ON
4 Flashes	Control lockout – failed to detect or sustain flame
5 Flashes	Flame sensed and gas valve not energize
6 Flashes	Pressure Switch closed with CAI OFF
7 Flashes	Not used
8 Flashes	Pressure switch opened repeatedly during heating demand

## Gas Heating Checks and Adjustments

### A-Gas Flow

To check for proper gas flow, determine the Btu input from the unit rating plate. Divide this input rating by the Btu per cubic feet of available gas. Result is the required number of cubic feet per hour. Determine the flow of gas through the gas meter for two minutes and multiply by 30 to get the hourly flow of gas.

### B-Supply Gas Pressure

Supply pressure should be checked with unit firing at maximum rate. For Natural Gas, supply pressure should be maintained in accordance with the specified minimum and maximum supply pressures on the unit rating plate.

For LP/propane, a natural gas to LP/propane gas changeover kit is required to convert the unit in the field. Refer to installation instructions provided with changeover kit for conversion procedure along with propane minimum and maximum supply pressures.

**NOTE** - On multiple unit installations, each unit should be checked separately, with and without other units operating. Supply pressures on both single and multiple unit installations must fall within range listed on the rating plate.

### C-Supply Gas Pressure Measurement

1 - Shut off the manual main supply valve (field furnished) when installing or removing the measuring device (Steps 2 and 6).

2 - Connect the measuring device based upon type of gas valve.

For White Rodgers 36H54 and 36H27 valves (FIGURE 35 and FIGURE 36), supply pressure is accessed by removing 1/8" hex screw. Remove the 1/8" hex screw and install a 1/8" fitting with hose barb. Connect tubing from the barbed fitting and route to measuring device to measure supply pressure.

3 - Open manual main supply valve.

4 - Ignite unit and let run for 5 minutes to allow for steady state conditions.

5 - After allowing unit to stabilize for 5 minutes, record supply pressure.

6 - Shut unit off and remove measuring device, tubing, or fittings as soon as an accurate reading has been obtained.

For White Rodgers 36H54 valve (FIGURE 35), remove supply pressure barbed fitting and reinstall the 1/8" hex screw.

For White Rodgers 36H27 valve (FIGURE 36), either remove supply pressure barbed fitting and reinstall the 1/8" hex screw or remove tubing from post, then turn the supply pressure 3/32" hex screw one revolution back into the gas valve.

### D-Manifold Pressure Measurement and Adjustment

1 - Connect the measuring device based upon the type of gas valve.

For White Rodgers 36H54 and 36H27 valves (FIGURE 35 and FIGURE 36) manifold pressure, remove the 1/8" hex screw, install 1/8" fitting with hose barb, connect hose from barb to "+" side of measuring device.

2 - Ignite unit and let run for 5 minutes to allow for steady state conditions. If unit has 2 heating inputs, start on higher input.

3 - After allowing unit to stabilize for 5 minutes, record manifold pressure. Compare measurement to the unit nameplate values.

**NOTE** - For elevations higher than 4500 feet above sea level, see High Altitude Adjustment section for details.

4 - If necessary, adjust manifold pressure. FIGURE 35 and FIGURE 36 show adjustment screw(s) locations.

5 - Repeat steps 3, 4 and 5 on lower input.

6 - Shut unit off and remove measuring device as soon as accurate reading has been obtained.

For White Rodgers 36H54 and 36H27 valves (FIGURE 35 and FIGURE 36), remove 1/8" fitting with hose barb and reinstall 1/8" hex screw.

7 - Start unit and perform leak check. Seal leaks if found.

### E-High Altitude Adjustments

Locate the high altitude conversion sticker in the unit literature bag. Fill out the conversion sticker and affix next to the unit nameplate. High altitude kits are available for field-installation.

Refer to TABLE 16 for high altitude adjustments.

TABLE 16

Altitude in Feet (Meters)*	Gas Manifold Pressure
2001 – 4500 (610 – 1372)	See unit nameplate
4500 (1372) and Above	Derate 4% per 1000 ft. (305 m) above sea level

\*Units installed at 0-2000 feet do not need to be modified

**NOTE** - This is the only permissible derate for these units.

## Electric Heat Start-Up (LHT Units)

### Factory- or Field-Installed Option

A W1 demand will energize compressors 1 and 2. An increased W2 heating demand will energize electric heat at low heat stage, W3 heating demand will energize electric heat at high stage. W1 will also energize electric heat during defrost to maintain discharge air temperature.

**NOTE** - L1 and L2 reversing valves are de-energized with a heating demand. The heat pump will heat only, not cool.

## Cooling Operation

This is a summary of cooling operation. Refer to the sequence of operation provided in the Engineering Handbook or Service Manual for more detail.

### A-Two-Stage Thermostat

#### 1 - Economizer With Outdoor Air Suitable

##### Y1 Demand -

Compressors Off  
Blower Cooling Low  
Dampers Modulate

##### Y2 Demand -

Compressors Off  
Blower Cooling High  
Dampers Modulate

**NOTE** - If dampers are at maximum open for five minutes, compressors are energized and blower stays on cooling high.

##### Y2 Demand -

Compressor Full Load  
Blower Cooling High Dampers  
Maximum Open

#### 2 - No Economizer or Outdoor Air Not Suitable

##### Y1 Demand -

Compressor 1 Full Load  
Blower Cooling Low  
Dampers Minimum Position

##### Y2 Demand -

Compressors Both Full Load  
Blower Cooling High  
Dampers Minimum Position

### B-Room Sensor

#### 1 - Economizer With Outdoor Air Suitable

Compressors Off  
Blower Modulates  
Dampers Modulate

**NOTE** - If dampers are at maximum open for five minutes, compressors are energized and the blower modulates.

#### 2 - No Economizer or Outdoor Air Not Suitable

Compressors 1 Full Load  
Blower High  
Dampers Minimum Position

### C-Three-Stage Thermostat

#### 1 - Economizer With Outdoor Air Suitable

##### Y1 Demand -

Compressors Off

Blower Cooling Medium

Dampers Modulate

##### Y2 Demand -

Compressors Off  
Blower Cooling High  
Dampers Modulate

**NOTE** - If dampers are at maximum open for five minutes, compressors are energized and blower stays on cooling high.

##### Y2 Demand -

Compressor 1 Part Load  
Blower Cooling High Dampers  
Maximum Open

##### Y3 Demand -

Compressor 1 Full Load  
Blower Cooling High  
Dampers Maximum Open

#### 2 - No Economizer or Outdoor Air Not Suitable

##### Y1 Demand -

Compressor 1 Part Load  
Blower Cooling Low  
Dampers Minimum Position

##### Y2 Demand -

Compressor 1 Part Load, Compressor 2 On  
Blower Cooling Medium  
Dampers Minimum Position

##### Y3 Demand -

Compressors Both Full Load  
Blower Cooling High  
Dampers Maximum Open

### D-Defrost

Defrost is enabled when outdoor coil temperature is below 35°F. The Unit Controller will cycle in and out of defrost depending on the temperature difference between the outdoor coil and outdoor air temperature.

Defrost is also initiated when the accumulated run time with the outdoor coil temperature below 35°F reaches six hours.

**NOTE** - Only one refrigerant circuit will go into defrost at a time

## Hot Gas Reheat Start-Up and Operation

### General

Hot gas reheat units provide a dehumidifying mode of operation. These units contain a reheat coil adjacent to and downstream of the evaporator coil. Reheat coil solenoid valve, L14, routes hot discharge gas from the compressor to the reheat coil. Return air pulled across the evaporator coil is cooled and dehumidified; the reheat coil adds heat to supply air. See FIGURE 37 for cooling refrigerant routing, FIGURE 38 for heating refrigerant routing and FIGURE 39 for reheat refrigerant routing.

### L14 Reheat Coil Solenoid Valve

When Unit Controller input (Unit Controller J298-5 or J299-8) indicates room conditions require dehumidification, L14 reheat valve is energized (Unit Controller P269-3) and refrigerant is routed to the reheat coil.

### Reheat Setpoint

Reheat is factory-set to energize when indoor relative humidity rises above 60% (default). The reheat setpoint can be adjusted by changing mobile service app Settings - Control menu. A setting of 100% will operate reheat from an energy management system digital output. The reheat setpoint can also be adjusted using an optional Network Control Panel (NCP).

Reheat will terminate when the indoor relative humidity falls 3% (57% default) or the digital output de-energizes. The reheat deadband can be adjusted at Settings - Control menu.

### Check-Out

Test reheat operation using the following procedure.  
Make sure reheat is wired as shown in wiring section.  
Make sure unit is in local thermostat mode.

Use mobile service app menu path to select:

**RTU MENU > COMPONENT TEST > DEHUMIDIFICATION**

*The blower, compressor, and reheat valve should be energized. Pressure can be checked on the reheat line pressure tap. Pressure on the reheat line should match discharge pressure closely in reheat mode.*

### Default Reheat Operation

During reheat mode free cooling is locked out.

No Y1 demand but a call for dehumidification:

Compressor is operating, blower is on, and the reheat valve is energized.

*Y1 demand:*

Compressor is operating, blower is on, and the reheat valve is de-energized.

*Y2 demand:*

Compressor is operating, blower is on, and the reheat valve is de-energized.

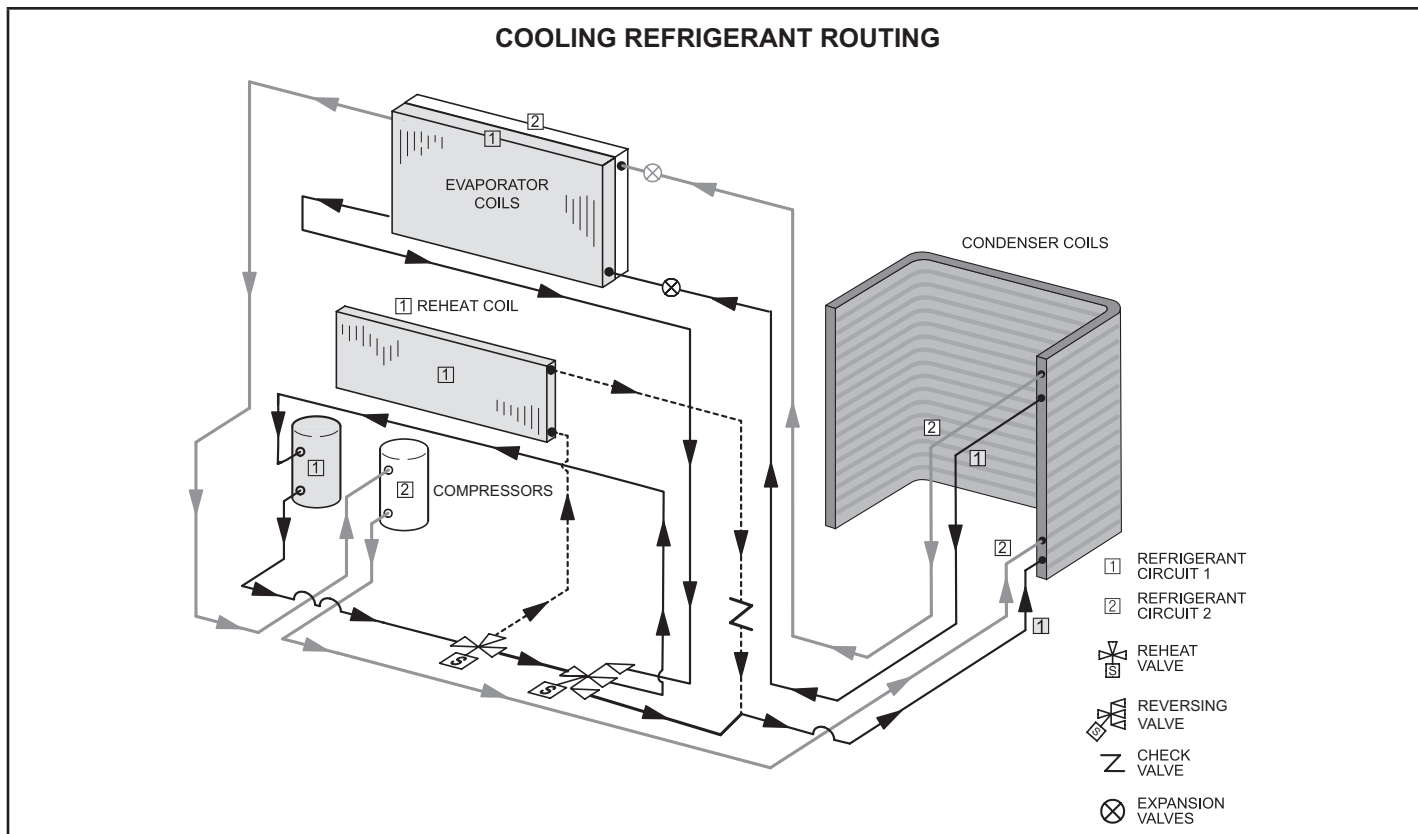


FIGURE 37

### HEATING REFRIGERANT ROUTING

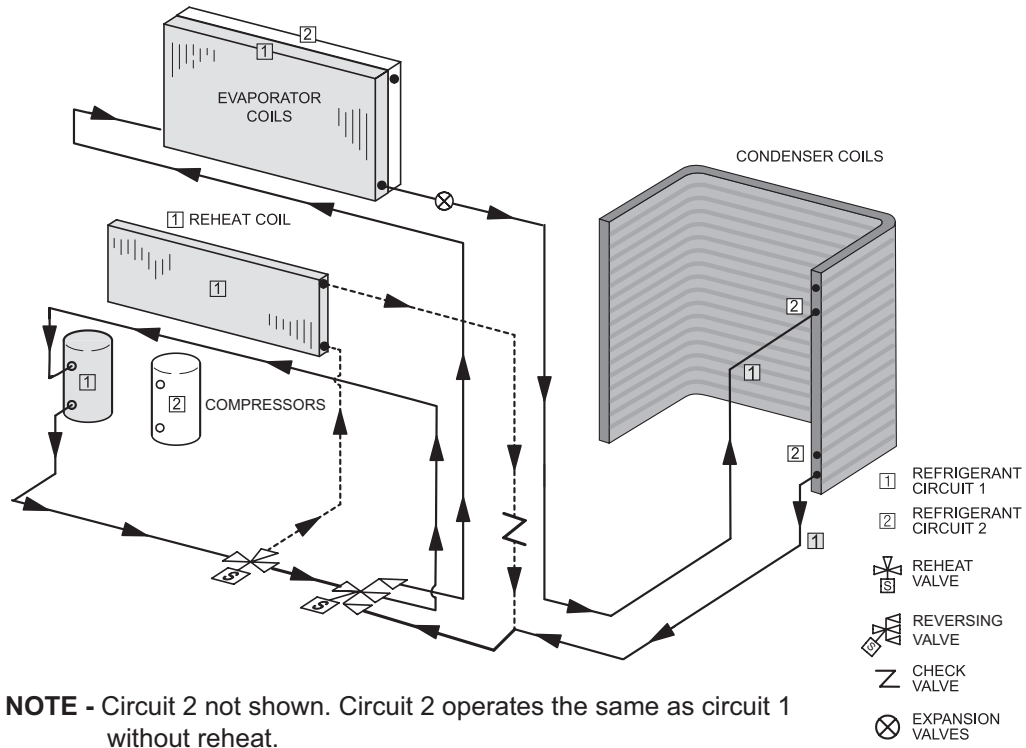


FIGURE 38

### REHEAT REFRIGERANT ROUTING

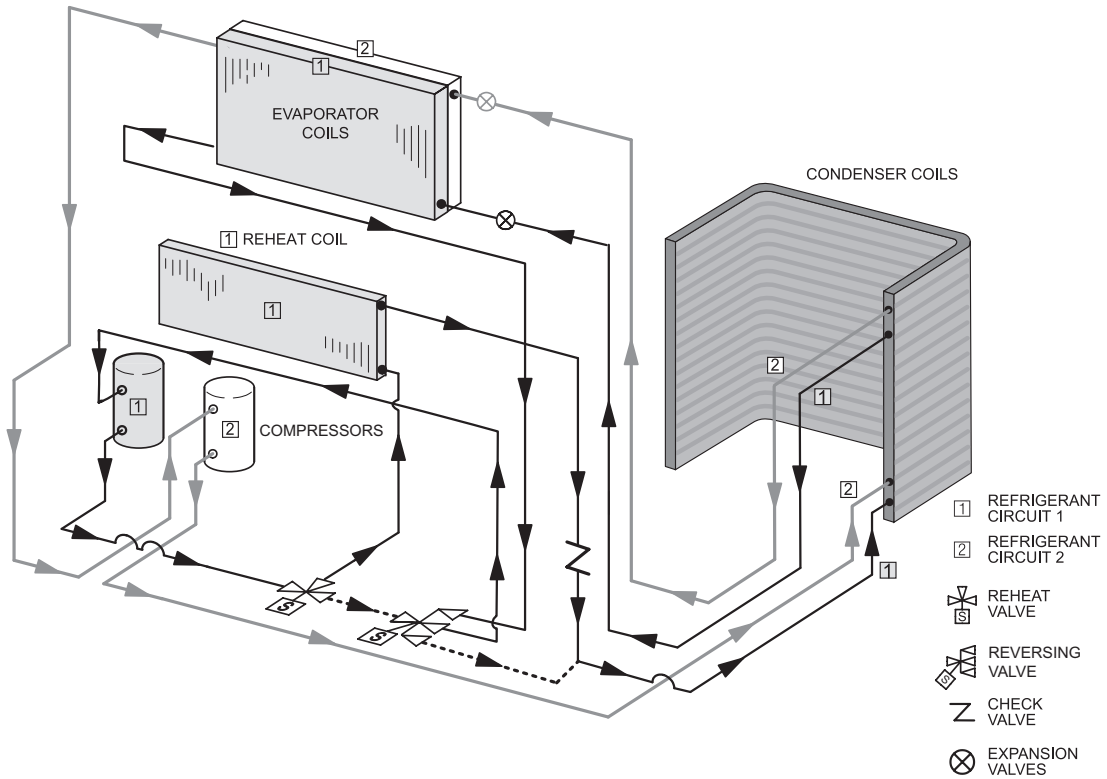


FIGURE 39

## Preventative Maintenance / Repair

### IMPORTANT MAINTENANCE / REPAIR SAFETY INSTRUCTIONS

Prior to beginning work on systems containing FLAMMABLE REFRIGERANTS, safety checks are necessary to ensure that the risk of ignition is minimized.

Work shall be undertaken under a controlled procedure to minimize the risk of a flammable gas or vapor being present while the work is being performed.

All maintenance staff and others working in the local area shall be instructed on the nature of work being carried out. Work in confined spaces shall be avoided.

The area shall be checked with an appropriate refrigerant detector prior to and during work, to ensure the technician is aware of potentially toxic or flammable atmospheres. Ensure that the leak detection equipment being used is suitable for use with all applicable refrigerants, i.e. non-sparking, adequately sealed or intrinsically safe.

If any hot work is to be conducted on the refrigerating equipment or any associated parts, appropriate fire extinguishing equipment shall be available to hand. Have a dry powder or CO2 fire extinguisher adjacent to the charging area.

No person carrying out work in relation to a REFRIGERATING SYSTEM which involves exposing any pipe work shall use any sources of ignition in such a manner that it may lead to the risk of fire or explosion. All possible ignition sources, including cigarette smoking, should be kept sufficiently far away from the site of installation, repairing, removing and disposal, during which refrigerant can possibly be released to the surrounding space. Prior to work taking place, the area around the equipment is to be surveyed to make sure that there are no flammable hazards or ignition risks. "No Smoking" signs shall be displayed.

Where electrical components are being changed, they shall be fit for the purpose and to the correct specification. At all times, the manufacturer's maintenance and service guidelines shall be followed. If in doubt, consult the manufacturer's technical department for assistance.

Repair and maintenance to electrical components shall include initial safety checks and component inspection procedures. If a fault exists that could compromise safety, then no electrical supply shall be connected to the circuit until it is satisfactorily dealt with. If the fault cannot be corrected immediately but it is necessary to continue operation, an adequate temporary solution shall be used. This shall be reported to the owner of the equipment so all parties are advised.

Initial safety checks shall include:

- that capacitors are discharged: this shall be done in a safe manner to avoid possibility of sparking
- that no live electrical components and wiring are exposed while charging, recovering or purging the system

- that there is continuity of earth bonding

The following checks shall be applied to installations using FLAMMABLE REFRIGERANTS:

- the actual REFRIGERANT CHARGE is in accordance with the room size within which the refrigerant containing parts are installed;
- the ventilation machinery and outlets are operating adequately and are not obstructed;
- if an indirect refrigerating circuit is being used, the secondary circuit shall be checked for the presence of refrigerant;
- marking to the equipment continues to be visible and legible. Markings and signs that are illegible shall be corrected;
- refrigerating pipe or components are installed in a position where they are unlikely to be exposed to any substance which may corrode refrigerant containing components, unless the components are constructed of materials which are inherently resistant to being corroded or are suitably protected against being so corroded.

During repairs to sealed electrical components, the components shall be replaced. Replacement parts shall be in accordance with the manufacturer's specifications.

During repairs to intrinsically safe components, the components must be replaced. Replace components only with parts specified by the manufacturer. Other parts may result in the ignition of refrigerant in the atmosphere from a leak.

The unit should be inspected once a year by a qualified service technician.

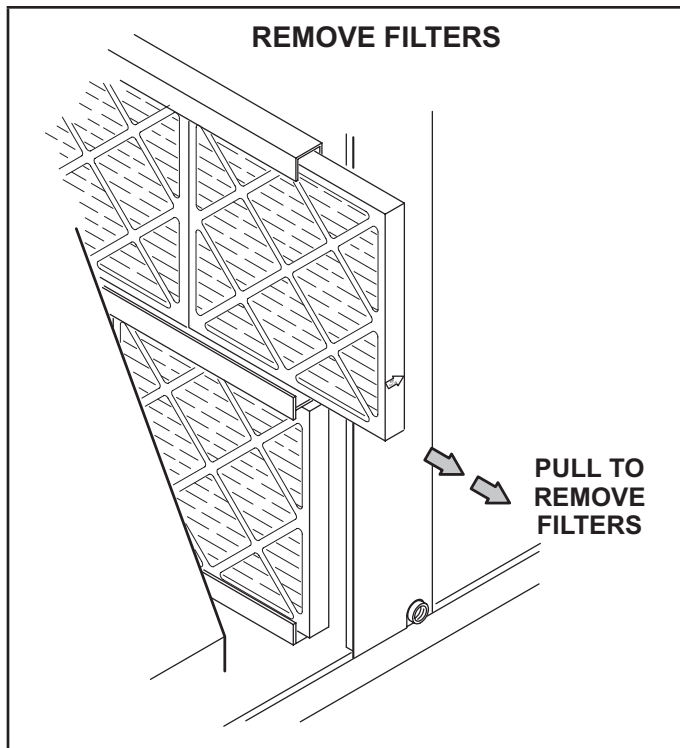
## CAUTION

Label all wires prior to disconnection when servicing controls. Wiring errors can cause improper and dangerous operation. Verify proper operation after servicing.

### A-Filters

Units are equipped with four 20 X 25 X 2" filters. Filters should be checked monthly and replaced when necessary with filters of like kind and size. Take note of air flow direction marking on filter frame when reinstalling filters. See FIGURE 40.

**NOTE** - Filters must be U.L.C. certified or equivalent for use in Canada.



**FIGURE 40**

**B-Lubrication**

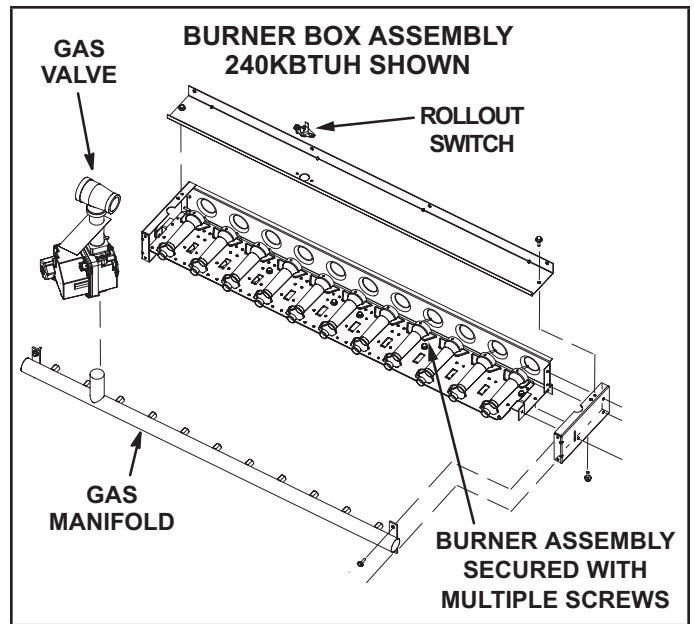
All motors are lubricated at the factory. No further lubrication is required.

**C-Burners (Gas Units)**

Periodically examine burner flames for proper appearance during the heating season. Before each heating season examine the burners for any deposits or blockage which may have occurred.

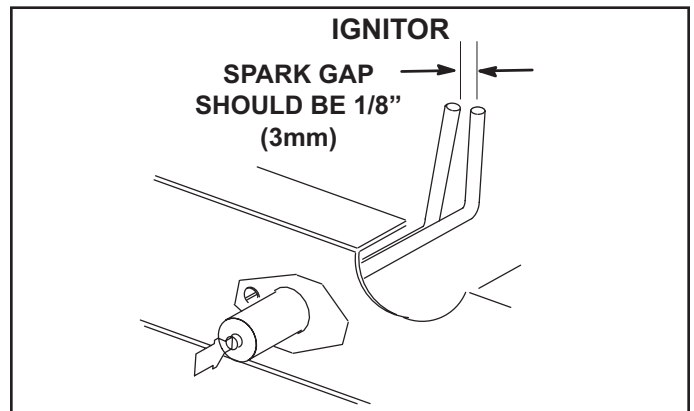
Clean burners as follows:

- 1 - Turn off both electrical power and gas supply to unit.
- 2 - Remove burner compartment access panel.
- 3 - Remove screws securing burner assembly to burner support and remove assembly. See FIGURE 41. Clean as necessary.



**FIGURE 41**

- 4 - Locate the ignitor under the left burners. Check ignitor spark gap with appropriately sized twist drills or feeler gauges. See FIGURE 42.



**FIGURE 42**

- 5 - Check the alignment of the ignitor and the sensor as shown in FIGURE 43 and TABLE 17.

**TABLE 17**

Dimension	Unit Btuh Input	Length - in. (mm)	
		Ignitor	Sensor
A	130K	7-3/4 (197)	11 (279)
B	180K	5 (127)	5-1/2 (140)
C	240K	2-1/4 (57)	2-3/4 (70)

- 6 - Replace burners and screws securing burner.
- 7 - Replace access panel.
- 8 - Restore electrical power and gas supply. Follow lighting instructions attached to unit and use inspection port in access panel to check flame.

**⚠ WARNING**

Danger of explosion. Can cause injury or death. Do not overtighten main burner mounting screws. Snug tighten only.

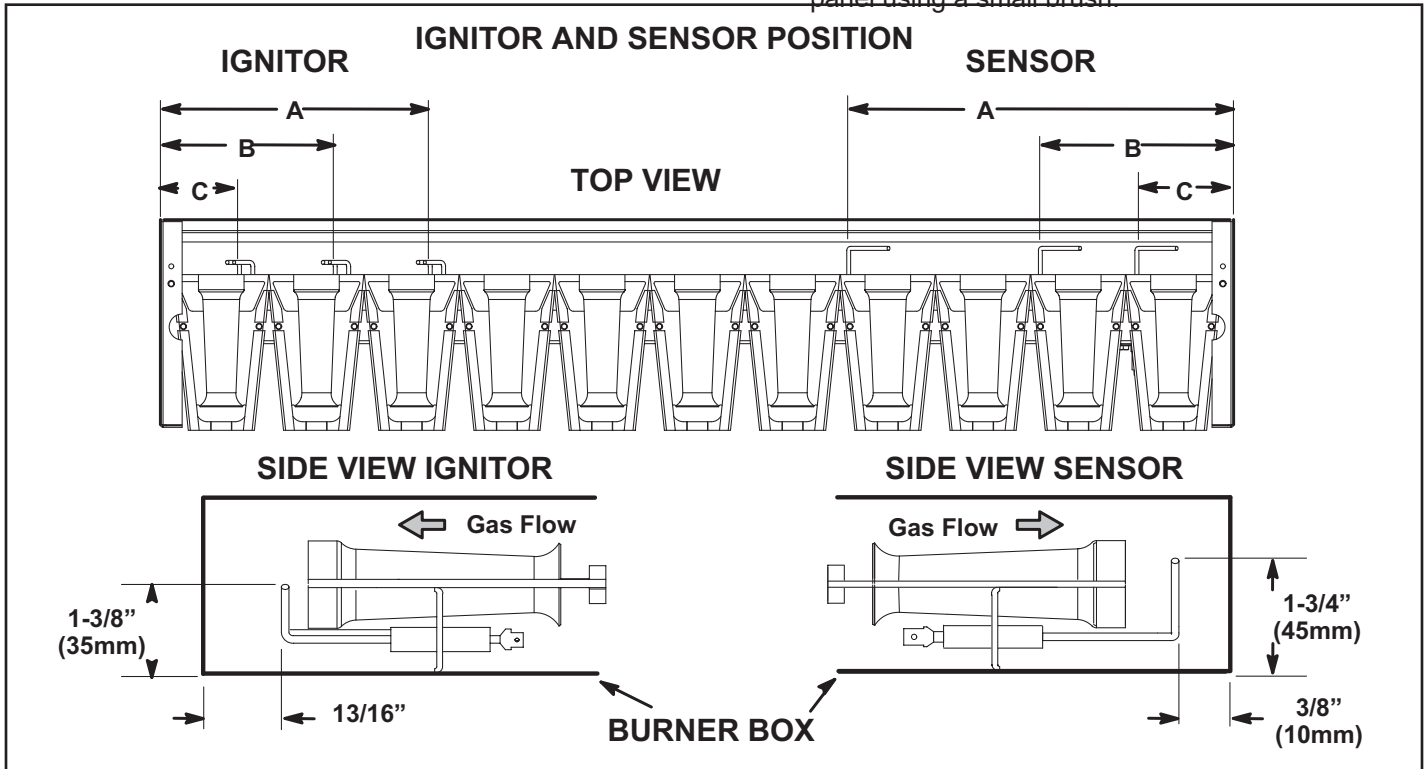
**D-Combustion Air Inducer (Gas Units)**

A combustion air proving switch checks combustion air inducer operation before allowing power to the gas controller. Gas controller will not operate if inducer is obstructed.

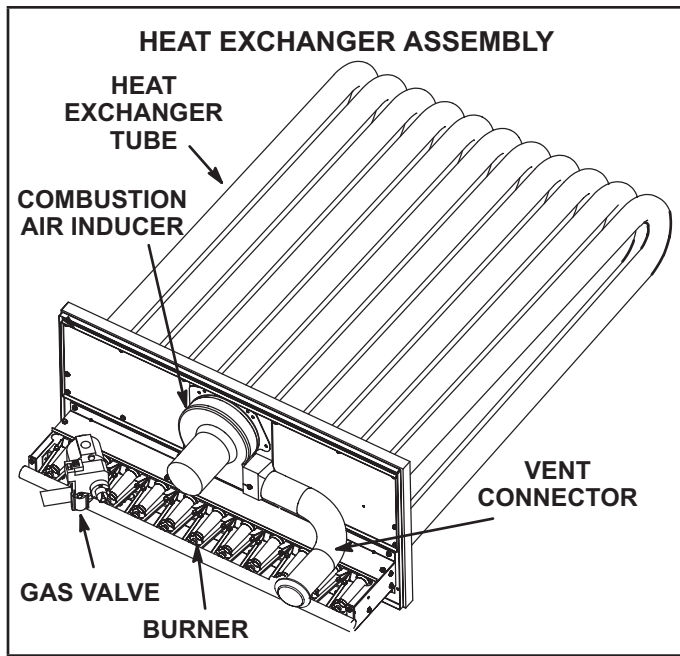
Under normal operating conditions, the combustion air inducer wheel should be checked and cleaned prior to the heating season. However, it should be examined periodically during the heating season to establish an ideal cleaning schedule. With power supply disconnected, the condition of the inducer wheel can be determined by looking through the vent opening.

Clean combustion air inducer as follows:

- 1 - Shut off power supply and gas to unit.
- 2 - Disconnect pressure switch air tubing from combustion air inducer port.
- 3 - Remove and retain screws securing combustion air inducer to flue box. Remove vent connector. See FIGURE 44.
- 4 - Clean inducer wheel blades with a small brush and wipe off any dust from housing. Clean accumulated dust from front of flue box cover.
- 5 - Return combustion air inducer motor and vent connector to original location and secure with retained screws. It is recommended that the combustion air inducer gasket be replaced during reassembly.
- 6 - Clean combustion air inlet louvers on heat access panel using a small brush.



**FIGURE 43**



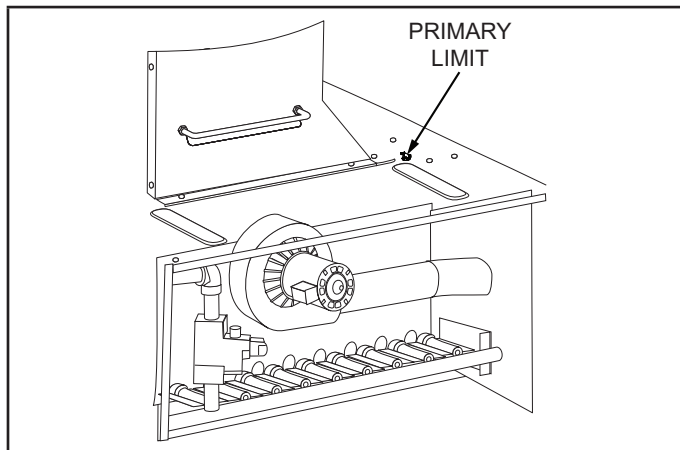
**FIGURE 44**

**E-Flue Passageway and Flue Box (Gas Units)**

- 1 - Remove combustion air inducer assembly as described in section D.
- 2 - Remove flue box cover. Clean with a wire brush as required.
- 3 - Clean tubes with a wire brush.
- 4 - Reassemble the unit. The flue box cover gasket and combustion air inducer gasket should also be replaced during reassembly.

**F-Limit Control Switch (S10)**

Limit controls are factory-set and are not adjustable. The primary limit is located on the blower deck to the right side of the blower housing. See FIGURE 45.



**FIGURE 45**

**G-Combustion Air Pressure Switch (S18)**

This pressure switch checks for proper combustion air inducer operation before allowing an ignition trial. The switch is factory-set. No field adjustment is necessary.

**H-Flame Roll out Switch (S47)**

This normally closed switch opens on a temperature rise. The roll out switch is factory-set and is not field adjustable. See FIGURE 41.

**I-Indoor Coil**

Inspect and clean coil at beginning of each cooling season. Clean using mild detergent or commercial coil cleaner. Flush coil and condensate drain with water taking care not to get insulation, filters and return air ducts wet.

**J-Supply Air Blower Wheel**

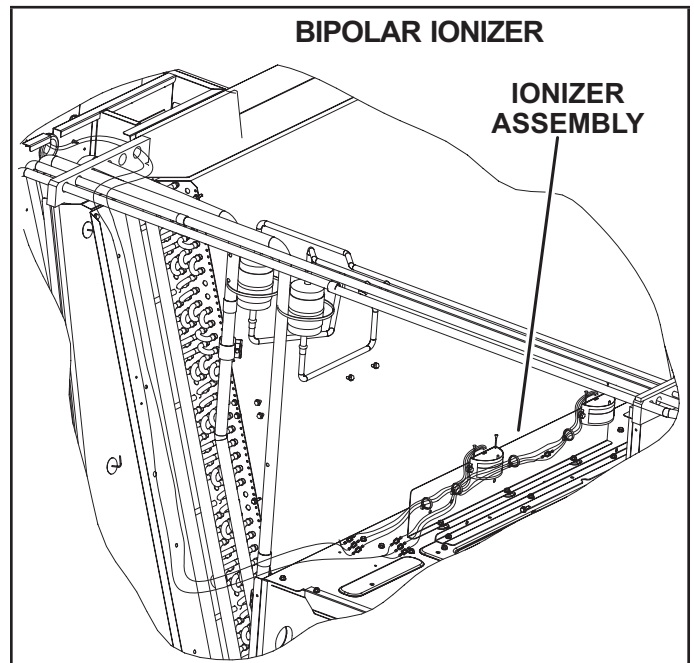
Annually inspect supply air blower wheel for accumulated dirt or dust. Turn off power before attempting to remove access panel or to clean blower wheel.

**K-Outdoor Coil**

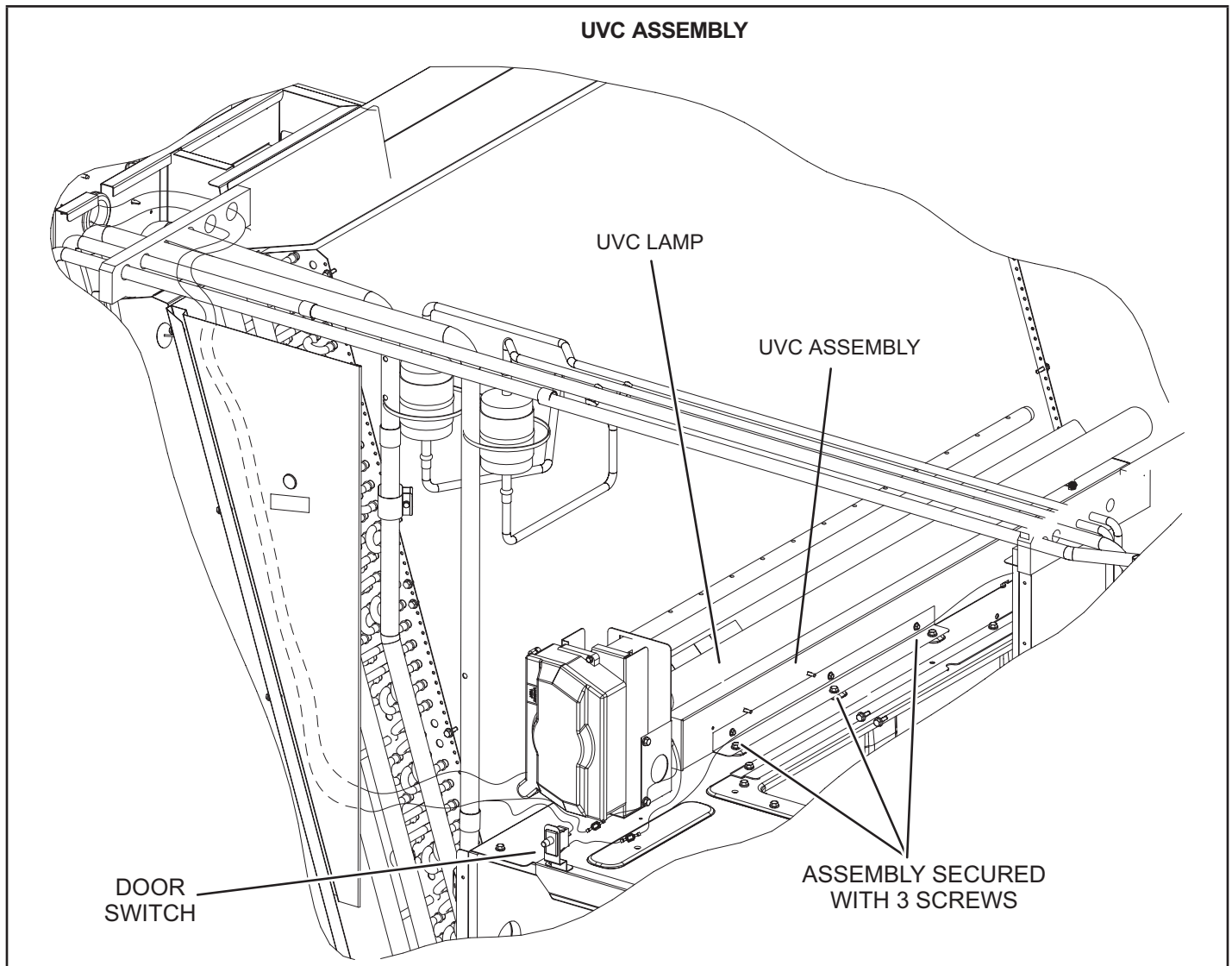
Clean outdoor coil annually with detergent or commercial coil cleaner and inspect monthly during the cooling season. Access panels are provided on front and back of outdoor section.

**L-Needlepoint Bipolar Ionizer**

The ionizer was designed for low maintenance. The device should be checked semi-annually to confirm the brushes are clean for maximum output. The ionizer is located on the blower deck. See FIGURE 46.



**FIGURE 46**



**FIGURE 47**

**M-UVC Light**

When field-installed, use only UVC Light Kit assembly 106882-01 (21A93) with this appliance.

**Factory-Installed UVC Light**

When the UVC light is factory installed, the lamp is shipped in a foam sleeve. The lamp is attached to the UVC light assembly on the blower deck. See FIGURE 47. Remove the lamp and install into the UVC light assembly as shown in steps 2 through 11.

**Annual Lamp Replacement**

**⚠ WARNING**

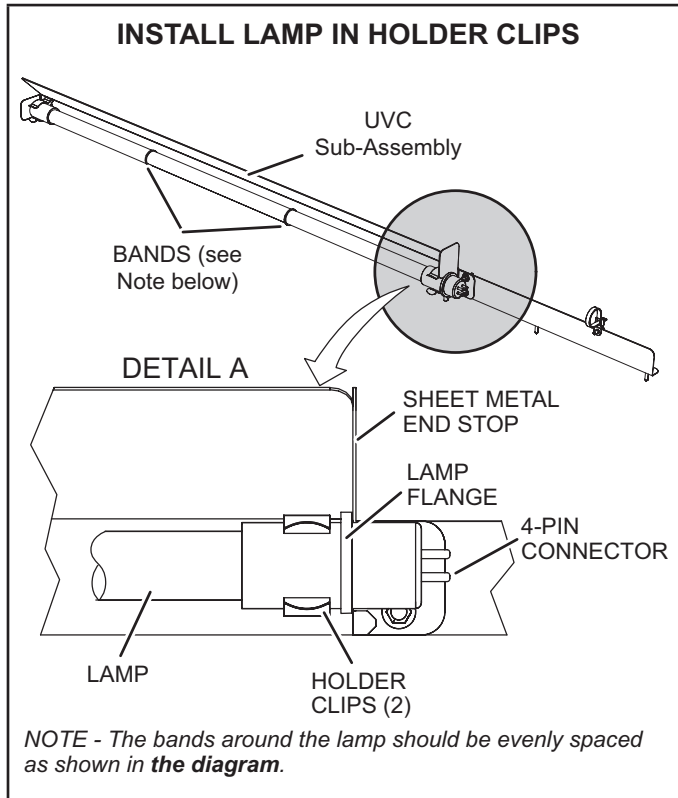
Personal Burn Hazard.

Personal injury may result from hot lamps. During replacement, allow lamp to cool for 10 minutes before removing lamp from fixture.

The lamp should be replaced every 12 months, as UVC energy production diminishes over time.

- 1 - Obtain replacement lamp 101087-01 for your germicidal light model.
- 2 - Disconnect power to the rooftop unit before servicing the UVC kit.
- 3 - Open the blower access door.
- 4 - Remove the screw in wire tie from the UVC assembly and disconnect the 4-pin connector from the lamp end.
- 5 - Remove and retain the (3) screws securing the UVC assembly. Carefully slide the complete UVC assembly out through the blower access door. See FIGURE 47.
- 6 - Allow 10 minutes before touching the lamps. Then, carefully remove the old lamp from the lamp holder clips.
- 7 - Wear cotton gloves or use a cotton cloth when handling the new lamp. Place the new lamp in the holder clips of the UVC assembly. Verify that the lamp flange at the connector end is sandwiched between the lamp holder clip and the sheet-metal end stop (see FIGURE 48).

- 8 - Carefully place the UVC assembly on the blower deck. Line up the mounting holes on the UVC assembly with the mounting holes on the blower deck. See FIGURE 47. Use the retained screws provided to attach the UVC assembly in place.
- 9 - Close the blower access door.
- 10 - Reconnect power to the rooftop unit.
- 11 - Open the filter access door and look through the view port in the triangular sheet-metal panel to verify that the UVC light is on.



**FIGURE 48**

If UVC lamp does not come on:

- 1 - Check Power Wiring: Disconnect 1/4" QC (quick connects) of the UVC cable near the UVC assembly. With Power ON, use multimeter to test 110-230V at the 1/4" QC quick connects from the control panel.
- 2 - Check Lamp: Carefully remove the UVC assembly out of the rooftop unit. Use multimeter to test for continuity across each pair of pins at each end of the lamp.
- 3 - Check Lamp Installation: Make sure that lamp's pins snap properly into the lamp holder.

**LED(s) not illuminated**

*Power status LED not lit*—Check that the lamp unit is connected to the proper power source and is wired correctly.

*Lamp status LED(s) not lit*—

- 1 - Check that lamp 4-pin connectors are properly engaged.

- 2 - Ohm-check across the lamp pins to check for continuity of lamp filaments (see FIGURE 50).

Troubleshooting charts are provided to aid in determining the cause of any problems encountered (FIGURE 49 and FIGURE 50).

**Lamp Disposal**

**Hg-LAMP Contains Mercury** - Manage in accordance with local, state and federal disposal laws. Refer to [www.lamprecycle.org](http://www.lamprecycle.org) or call 800-953-6669.

**Proper Clean-up Technique in Case of Lamp Breakage**

Wear protective gloves, eye wear and mask.

Sweep the broken glass and debris into a plastic bag, seal the bag, and dispose of properly. Contact your local waste management office for proper disposal.

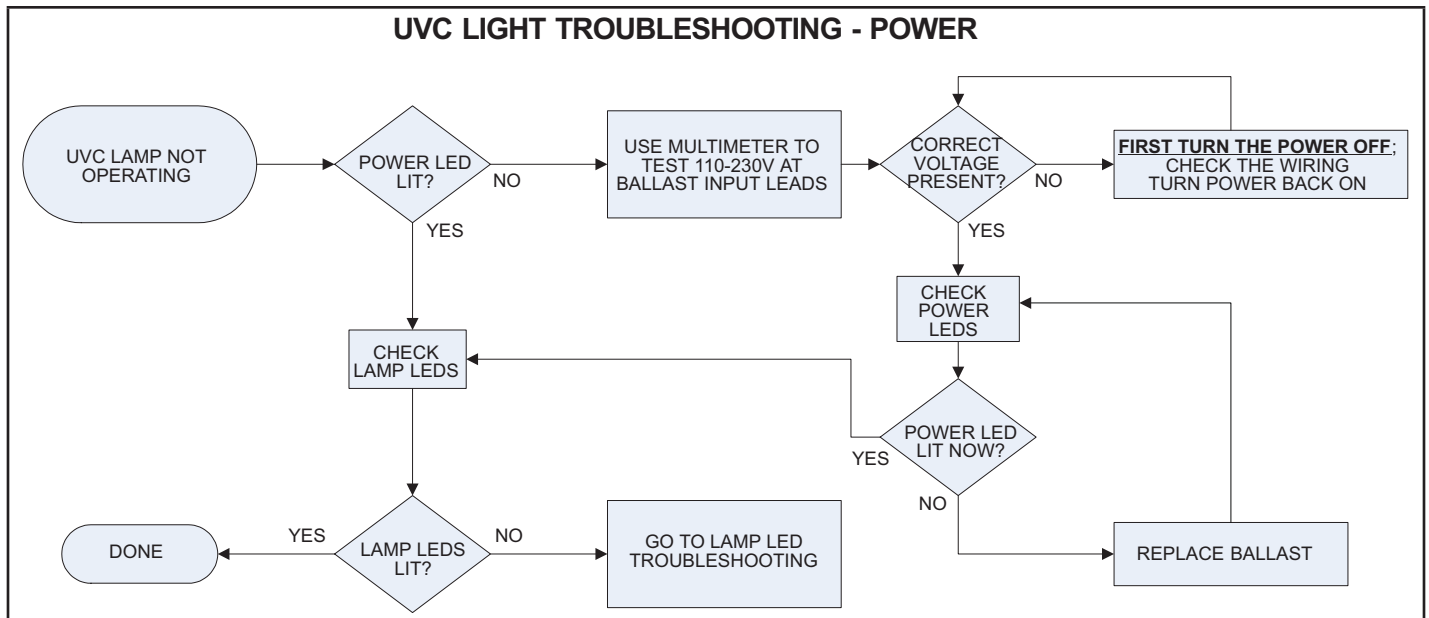
**Do not use a vacuum cleaner. Do not incinerate.**

**Maintenance**

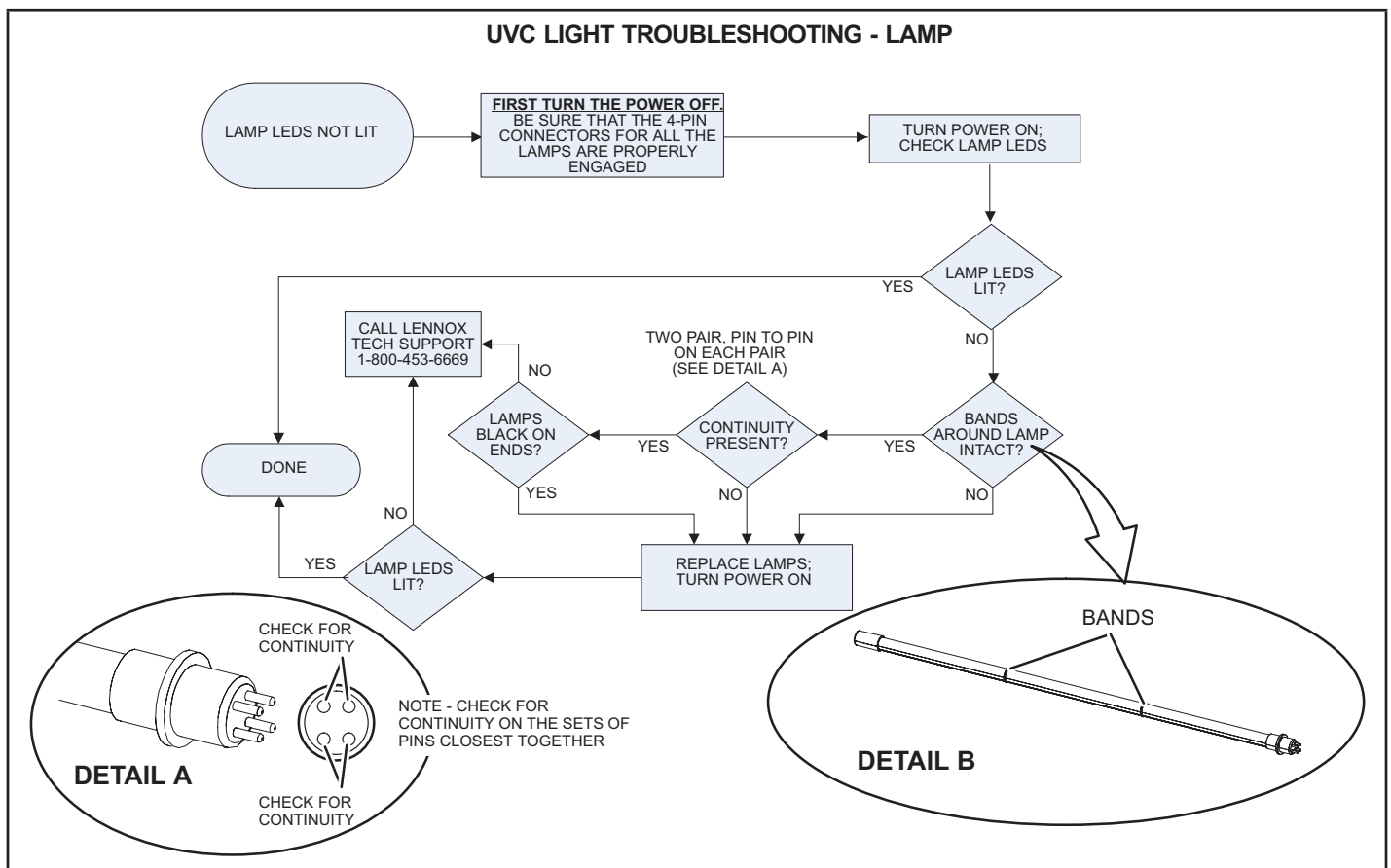
- For all maintenance, contact a qualified HVAC technician.
- Read the maintenance instructions before opening unit panels.
- Unintended use of the unit or damage to the unit housing may result in the escape of dangerous UVC radiation. UVC radiation may, even in small doses, cause harm to the eyes and skin.
- Do not operate units that are obviously damaged.
- Do not discard the triangular UVC light shield or any barriers with an ultraviolet radiation symbol.
- Do not override the door interlock switch that interrupts power to the UVC light.
- Do not operate the UVC light outside of the unit.

**! DANGER**

Ultraviolet (UVC) Radiation hazard.  
Any exposure will cause significant eye damage and may cause skin damage.  
**DO NOT** look into UVC light source.  
Access panels must be in place during appliance operation.



**FIGURE 49**



**FIGURE 50**

## N-Replacement Fuses

See the following tables for the proper replacement fuse sizes.

ELECTRIC HEAT REPLACEMENT FUSES					
	kW	Fuse Part Number	Qty.	Rating	
				Amp	Volt
1	E1EHO075BP1Y	7.5 kW Y Volt	3	25	250
2	E1EHO075BP1G	7.5 kW G Volt	3	51	600
3	E1EHO075BP1J	7.5 kW J Volt	3	10	600
4	E1EHO150BP1Y	15 kW Y Volt	3	50	250
5	E1EHO150BP1G	15 kW G Volt	3	25	600
6	E1EHO150BP1J	15 KW J Volt	3	20	600
7	E1EHO225BP1Y	22.5 KW Y Volt	3 EA.	50 & 25	250
8	E1EHO225BP1G	22.5 KW G Volt	3 EA.	25 & 15	600
9	E1EHO225BP1J	22.5 KW J Volt	3 EA.	20 & 10	600
10	E1EHO300BP1Y	30 KW Y Volt	6	50	250
11	E1EHO300BP1G	30 KW G Volt	6	25	600
12	E1EHO300BP1J	30 KW J Volt	6	20	600
13	E1EHO450BP1Y	45 KW Y Volt	3/6	50 & 60	250
14	E1EHO450BP1G	45 KW G Volt	3 EA.	25 & 50	600
15	E1EHO450BP1J	45 KW J Volt	3 EA.	20 & 40	600
16	E1EHO600BP1Y	60 KW Y Volt	12	60	250
17	E1EHO600BP1G	60 KW G Volt	6	50	600
18	E1EHO600BP1J	60 KW J Volt	6	40	600

**TABLE 18**

LDT 078								
Unit Voltage			208/230V - 3 Ph		460V - 3Ph		575V - 3Ph	
Power Exhaust Option			W / P.E.	W / O P.E.	W / P.E.	W / O P.E.	W / P.E.	W / O P.E.
Diagram Key	Class	Blower HP	Amps					
F10	CC	3.75	12	12	12	12	12	12
F57	CC	3.75	-	-	7.5	7.5	4	4
F30	CC	3.75	10	10	5	5	-	-
F31	CC	3.75	15	15	15	15	-	-
F61 <sup>2</sup>	J	3.75	50	45	25	25	20	20
CB10 <sup>3</sup>	-	3.75	50	45	25	25	20	20

<sup>2</sup> Fuses F61 are only used on units with SCCR installed.

<sup>3</sup> Units using Circuit Breakers will use CB10 option.

**TABLE 19**

LDT 092								
Unit Voltage			208/230V - 3 Ph		460V - 3Ph		575V - 3Ph	
Power Exhaust Option			W / P.E.	W / O P.E.	W / P.E.	W / O P.E.	W / P.E.	W / O P.E.
Diagram Key	Class	Blower HP	Amps					
F10	CC	3.75	12	12	12	12	12	12
F57	CC	3.75	-	-	7.5	7.5	4	4
F30	CC	3.75	10	10	5	10	-	-
F31	CC	3.75	15	15	15	15	-	-
F61 <sup>2</sup>	J	3.75	50	50	25	25	20	20
CB10 <sup>3</sup>	-	3.75	50	50	25	25	20	20

<sup>2</sup> Fuses F61 are only used on units with SCCR installed.

<sup>3</sup> Units using Circuit Breakers will use CB10 option.

**TABLE 20**

LDT 102								
Unit Voltage			208/230V - 3 Ph		460V - 3Ph		575V - 3Ph	
Power Exhaust Option			W / P.E.	W / O P.E.	W / P.E.	W / O P.E.	W / P.E.	W / O P.E.
Diagram Key	Class	Blower HP	Amps					
F10	CC	3.75	12	12	12	12	12	12
F57	CC	3.75	10	10	5	5	-	-
F30	CC	3.75	15	15	15	15	-	-
F31	CC	3.75	-	-	7.5	7.5	4	4
F61 <sup>2</sup>	J	3.75	60	60	30	25	25	25
CB10 <sup>3</sup>	-	3.75	60	60	30	25	25	25

<sup>2</sup> Fuses F61 are only used on units with SCCR installed.

<sup>3</sup> Units using Circuit Breakers will use CB10 option.

**TABLE 21**

LDT 120								
Unit Voltage			208/230V - 3 Ph		460V - 3Ph		575V - 3Ph	
Power Exhaust Option			W / P.E.	W / O P.E.	W / P.E.	W / O P.E.	W / P.E.	W / O P.E.
Diagram Key	Class	Blower HP	Amps					
F10	CC	3.75	12	12	12	12	12	12
F57	CC	3.75	10	10	5	5	-	-
F30	CC	3.75	15	15	15	15	-	-
F31	CC	3.75	-	-	7.5	7.5	4	4
F61 <sup>2</sup>	J	3.75	70	60	30	30	25	25
CB10 <sup>3</sup>	-	3.75	70	60	30	30	25	25

<sup>2</sup> Fuses F61 are only used on units with SCCR installed.

<sup>3</sup> Units using Circuit Breakers will use CB10 option.

**TABLE 22**

LDT 152								
Unit Voltage			208/230V - 3 Ph		460V - 3Ph		575V - 3Ph	
Power Exhaust Option			W / P.E.	W / O P.E.	W / P.E.	W / O P.E.	W / P.E.	W / O P.E.
Diagram Key	Class	Blower HP	Amps					
F10	CC	3.75	12	12	12	12	12	12
F57	CC	3.75	10	10	5	5	-	-
F30	CC	3.75	15	15	15	15	-	-
F31	CC	3.75	-	-	7.5	7.5	4	4
F61 <sup>2</sup>	J	3.75	90	80	40	35	30	30
CB10 <sup>3</sup>	-	3.75	90	80	40	35	30	30

<sup>2</sup> Fuses F61 are only used on units with SCCR installed.

<sup>3</sup> Units using Circuit Breakers will use CB10 option.

**TABLE 23**

LHT 078																
Electric Heat Size			0 KW						7.5 KW							
Unit Voltage			208/230V - 3 Ph		460V - 3 Ph		575V - 3 Ph		208V- 3 Ph		240V - 3 Ph		460V - 3 Ph		575V - 3 Ph	
Power Exhaust Option			W / P.E.	W / O P.E.	W / P.E.	W / O P.E.	W / P.E.	W / O P.E.	W / P.E.	W / O P.E.	W / P.E.	W / O P.E.	W / P.E.	W / O P.E.	W / P.E.	W / O P.E.
Diagram Key	Class	Blower HP	Amps													
F4	RK or K <sup>1</sup> or J	3.75	50	45	25	25	20	20	50	45	50	45	25	25	20	20
F10	CC	3.75	12	12	12	12	12	12	12	12	12	12	12	12	12	12
F57	CC	3.75	-	-	7.5	7.5	4	4	-	-	-	-	7.5	7.5	4	4
F30	CC	3.75	10	10	5	5	-	-	10	10	10	10	5	5	-	-
F31	CC	3.75	15	15	15	15	-	-	15	15	15	15	15	15	-	-
F61 <sup>2</sup>	J	3.75	-	-	-	-	-	-	60	60	70	70	35	35	30	25
CB10 <sup>3</sup>	-	3.75	50	45	25	25	20	20	60	60	70	70	35	35	30	25

<sup>1</sup> When SCCR is installed, F4 fuse is Class J.

<sup>2</sup> Fuses F61 are only used on units with SCCR installed.

<sup>3</sup> Units using Circuit Breakers will use CB10 option.

**TABLE 24**

LHT 078 continued																		
Electric Heat Size			15 KW								22.5 KW							
Unit Voltage			208V - 3 Ph		240V - 3 Ph		460V - 3Ph		575V - 3Ph		208V - 3 Ph		240V - 3 Ph		460V - 3Ph		575V - 3Ph	
Power Exhaust Option			W / P.E.	W / O P.E.	W / P.E.	W / O P.E.	W / P.E.	W / O P.E.	W / P.E.	W / O P.E.	W / P.E.	W / O P.E.	W / P.E.	W / O P.E.	W / P.E.	W / O P.E.	W / P.E.	W / O P.E.
Diagram Key	Class	Blower HP	Amps															
F4	RK or K <sup>1</sup> or J	3.75	50	45	50	45	25	25	20	20	50	45	50	45	25	25	20	20
F10	CC	3.75	12	12	12	12	12	12	12	12	12	12	12	12	12	12	12	12
F57	CC	3.75	-	-	-	-	7.5	7.5	4	4	-	-	-	-	7.5	7.5	4	4
F30	CC	3.75	10	10	10	10	5	5	-	-	10	10	10	10	5	5	-	-
F31	CC	3.75	15	15	15	15	15	15	-	-	15	15	15	15	15	15	-	-
F61 <sup>2</sup>	J	3.75	80	80	90	90	45	45	35	35	100	100	110	110	60	60	45	45
CB10 <sup>3</sup>	-	3.75	80	80	90	90	45	45	35	35	100	100	110	110	60	60	45	45

<sup>1</sup> When SCCR is installed, F4 fuse is Class J.

<sup>2</sup> Fuses F61 are only used on units with SCCR installed.

<sup>3</sup> Units using Circuit Breakers will use CB10 option.

**TABLE 25**

LHT 078 continued										
Electric Heat Size			30 KW							
Unit Voltage			208V - 3 Ph		240V - 3 Ph		460V - 3 Ph		575V - 3 Ph	
Power Exhaust Option			W / P.E.	W / O P.E.	W / P.E.	W / O P.E.	W / P.E.	W / O P.E.	W / P.E.	W / O P.E.
Diagram Key	Class	Blower HP	Amps							
F4	RK or K <sup>1</sup> or J	3.75	50	45	50	45	25	25	20	20
F10	CC	3.75	12	12	12	12	12	12	12	12
F57	CC	3.75	-	-	-	-	7.5	7.5	4	4
F30	CC	3.75	10	10	10	10	5	5	-	-
F31	CC	3.75	15	15	15	15	15	15	-	-
F61 <sup>2</sup>	J	3.75	125	125	150	150	70	70	60	60
CB10 <sup>3</sup>	-	3.75	125	125	150	150	70	70	60	60

<sup>1</sup> When SCCR is installed, F4 fuse is Class J.

<sup>2</sup> Fuses F61 are only used on units with SCCR installed.

<sup>3</sup> Units using Circuit Breakers will use CB10 option.

**TABLE 26**

LHT 092																
Electric Heat Size			0 KW						7.5 KW							
Unit Voltage			208/230V - 3 Ph		460V - 3 Ph		575V - 3 Ph		208V - 3 Ph		240V - 3 Ph		460V - 3 Ph		575V - 3 Ph	
Power Exhaust Option			W / P.E.	W / O P.E.	W / P.E.	W / O P.E.	W / P.E.	W / O P.E.	W / P.E.	W / O P.E.	W / P.E.	W / O P.E.	W / P.E.	W / O P.E.	W / P.E.	W / O P.E.
Diagram Key	Class	Blower HP	Amps													
F4	RK or K <sup>1</sup> or J	3.75	50	50	25	25	20	20	50	50	50	50	25	25	20	20
F10	CC	3.75	12	12	12	12	12	12	12	12	12	12	12	12	12	12
F57	CC	3.75	-	-	7.5	7.5	4	4	-	-	-	-	7.5	7.5	4	4
F30	CC	3.75	10	10	5	10	-	-	10	10	10	10	5	10	-	-
F31	CC	3.75	15	15	15	15	-	-	15	15	15	15	15	15	-	-
F61 <sup>2</sup>	J	3.75	-	-	-	-	-	-	70	70	70	70	35	70	30	30
CB10 <sup>3</sup>	-	3.75	50	50	25	25	20	20	70	70	70	70	35	70	30	30

<sup>1</sup> When SCCR is installed, F4 fuse is Class J.

<sup>2</sup> Fuses F61 are only used on units with SCCR installed.

<sup>3</sup> Units using Circuit Breakers will use CB10 option.

**TABLE 27**

LHT 092 continued																		
Electric Heat Size			15 KW								22.5 KW							
Unit Voltage			208V - 3 Ph		240V - 3 Ph		460V - 3Ph		575V - 3Ph		208V - 3 Ph		240V - 3 Ph		460V - 3Ph		575V - 3Ph	
Power Exhaust Option			W / P.E.	W / O P.E.	W / P.E.	W / O P.E.	W / P.E.	W / O P.E.	W / P.E.	W / O P.E.	W / P.E.	W / O P.E.	W / P.E.	W / O P.E.	W / P.E.	W / O P.E.	W / P.E.	W / O P.E.
Diagram Key	Class	Blower HP	Amps															
F4	RK or K <sup>1</sup> or J	3.75	50	50	50	50	25	25	20	20	50	50	50	50	25	25	20	20
F10	CC	3.75	12	12	12	12	12	12	12	12	12	12	12	12	12	12	12	12
F57	CC	3.75	-	-	-	-	7.5	7.5	4	4	-	-	-	-	7.5	7.5	4	4
F30	CC	3.75	10	10	10	10	5	5	-	-	10	-	10	10	5	5	-	-
F31	CC	3.75	15	15	15	15	15	15	-	-	15	-	15	15	15	15	-	-
F61 <sup>2</sup>	J	3.75	90	90	90	90	50	45	40	40	110	40	125	110	60	60	50	45
CB10 <sup>3</sup>	-	3.75	90	90	90	90	50	45	40	40	110	40	125	110	60	60	50	45

<sup>1</sup> When SCCR is installed, F4 fuse is Class J.

<sup>2</sup> Fuses F61 are only used on units with SCCR installed.

<sup>3</sup> Units using Circuit Breakers will use CB10 option.

**TABLE 28**

LHT 092 continued																		
Electric Heat Size			30 KW								45 KW							
Unit Voltage			208V - 3 Ph		240V - 3 Ph		460V - 3 Ph		575V - 3 Ph		208V - 3 Ph		240V - 3 Ph		460V - 3Ph		575V - 3 Ph	
Power Exhaust Option			W / P.E.	W / O P.E.	W / P.E.	W / O P.E.	W / P.E.	W / O P.E.	W / P.E.	W / O P.E.	W / P.E.	W / O P.E.	W / P.E.	W / O P.E.	W / P.E.	W / O P.E.	W / P.E.	W / O P.E.
Diagram Key	Class	Blower HP	Amps															
F4	RK or K <sup>1</sup> or J	3.75	50	50	50	50	25	25	20	20	50	50	50	50	25	25	20	20
F10	CC	3.75	12	12	12	12	12	12	12	12	12	12	12	12	12	12	12	12
F57	CC	3.75	-	-	-	-	7.5	7.5	4	4								
F30	CC	3.75	10	10	10	10	5	5	-	-	10	10	10	10	5	5	-	-
F31	CC	3.75	15	15	15	15	15	15	-	-	15	15	15	15	15	15	-	-
F61 <sup>2</sup>	J	3.75	125	125	150	150	70	70	60	60	N	N	N	N	100	90	80	80
CB10 <sup>3</sup>	-	3.75	125	125	150	150	70	70	60	60	175	175	200	200	100	90	80	80

<sup>1</sup> When SCCR is installed, F4 fuse is Class J.

<sup>2</sup> Fuses F61 are only used on units with SCCR installed.

<sup>3</sup> Units using Circuit Breakers will use CB10 option.

**TABLE 29**

LHT 102																		
Electric Heat Size			0 KW								7.5 KW							
Unit Voltage			208/230V - 3 Ph		460V - 3 Ph		575V - 3 Ph		208V - 3 Ph		240V - 3 Ph		460V - 3 Ph		575V - 3 Ph			
Power Exhaust Option			W / P.E.	W / O P.E.	W / P.E.	W / O P.E.	W / P.E.	W / O P.E.	W / P.E.	W / O P.E.	W / P.E.	W / O P.E.	W / P.E.	W / O P.E.	W / P.E.	W / O P.E.	W / P.E.	W / O P.E.
Diagram Key	Class	Blower HP	Amps															
F4	RK or K <sup>1</sup> or J	3.75	60	60	30	25	25	25	60	60	60	60	30	25	25	25	25	25
F10	CC	3.75	12	12	12	12	12	12	12	12	12	12	12	12	12	12	12	12
F30	CC	3.75	10	10	5	5	-	-	10	10	10	10	5	5	-	-	-	-
F31	CC	3.75	15	15	15	15	-	-	15	15	15	15	15	15	15	-	-	-
F57	CC	3.75	-	-	7.5	7.5	4	4	-	-	-	-	7.5	7.5	4	4	4	4
F61 <sup>2</sup>	J	3.75	-	-	-	-	-	-	70	70	80	70	40	35	30	30	30	30
CB10 <sup>3</sup>	-	3.75	60	60	30	25	25	25	70	70	80	70	40	35	30	30	30	30

<sup>1</sup> When SCCR is installed, F4 fuse is Class J.

<sup>2</sup> Fuses F61 are only used on units with SCCR installed.

<sup>3</sup> Units using Circuit Breakers will use CB10 option.

**TABLE 30**

LHT 102 continued																		
Electric Heat Size			15 KW								22.5 KW							
Unit Voltage			208V - 3 Ph		240V - 3 Ph		460V - 3Ph		575V - 3Ph		208V - 3 Ph		240V - 3 Ph		460V - 3Ph		575V - 3Ph	
Power Exhaust Option			W / P.E.	W / O P.E.	W / P.E.	W / O P.E.	W / P.E.	W / O P.E.	W / P.E.	W / O P.E.	W / P.E.	W / O P.E.	W / P.E.	W / O P.E.	W / P.E.	W / O P.E.	W / P.E.	W / O P.E.
Diagram Key	Class	Blower HP	Amps															
F4	RK or K <sup>1</sup> or J	3.75	60	60	60	60	30	25	25	25	60	60	60	60	30	25	25	25
F10	CC	3.75	12	12	12	12	12	12	12	12	12	12	12	12	12	12	12	12
F30	CC	3.75	10	10	10	10	5	5	-	-	10	10	10	10	5	5	-	-
F31	CC	3.75	15	15	15	15	15	15	-	-	15	15	15	15	15	15	-	-
F57	CC	3.75	-	-	-	-	7.5	7.5	4	4	-	-	-	-	7.5	7.5	4	4
F61 <sup>2</sup>	J	3.75	90	90	100	100	50	50	40	40	110	110	125	125	60	60	50	50
CB10 <sup>3</sup>	-	3.75	90	90	100	100	50	50	40	40	110	110	125	125	60	60	50	50

<sup>1</sup> When SCCR is installed, F4 fuse is Class J.

<sup>2</sup> Fuses F61 are only used on units with SCCR installed.

<sup>3</sup> Units using Circuit Breakers will use CB10 option.

**TABLE 31**

LHT 102 continued																		
Electric Heat Size			30 KW								45 KW							
Unit Voltage			208V - 3 Ph		240V - 3 Ph		460V - 3 Ph		575V - 3 Ph		208V - 3 Ph		240V - 3 Ph		460V - 3Ph		575V - 3 Ph	
Power Exhaust Option			W / P.E.	W / O P.E.	W / P.E.	W / O P.E.	W / P.E.	W / O P.E.	W / P.E.	W / O P.E.	W / P.E.	W / O P.E.	W / P.E.	W / O P.E.	W / P.E.	W / O P.E.	W / P.E.	W / O P.E.
Diagram Key	Class	Blower HP	Amps															
F4	RK or K <sup>1</sup> or J	3.75	60	60	60	60	30	25	25	25	60	60	60	60	30	25	25	25
F10	CC	3.75	12	12	12	12	12	12	12	12	12	12	12	12	12	12	12	12
F30	CC	3.75	10	10	10	10	5	5	-	-	10	10	10	10	5	5	-	-
F31	CC	3.75	15	15	15	15	15	15	-	-	15	15	15	15	15	15	-	-
F57	CC	3.75	-	-	-	-	7.5	7.5	4	4	-	-	-	-	7.5	7.5	4	4
F61 <sup>2</sup>	J	3.75	150	125	150	150	70	70	60	60	N	N	N	N	100	100	80	80
CB10 <sup>3</sup>	-	3.75	150	125	150	150	70	70	60	60	175	175	200	200	100	100	80	80

<sup>1</sup> When SCCR is installed, F4 fuse is Class J.

<sup>2</sup> Fuses F61 are only used on units with SCCR installed.

<sup>3</sup> Units using Circuit Breakers will use CB10 option.

**TABLE 32**

LHT 120																
Electric Heat Size			0 KW						15 KW							
Unit Voltage			208/230V - 3 Ph		460V - 3 Ph		575V - 3 Ph		208V - 3 Ph		240V - 3 Ph		460V - 3 Ph		575V - 3 Ph	
Power Exhaust Option			W / P.E.	W / O P.E.	W / P.E.	W / O P.E.	W / P.E.	W / O P.E.	W / P.E.	W / O P.E.	W / P.E.	W / O P.E.	W / P.E.	W / O P.E.	W / P.E.	W / O P.E.
Diagram Key	Class	Blower HP	Amps													
F4	RK or K <sup>1</sup> or J	3.75	70	60	30	30	25	25	70	60	70	60	30	30	25	25
F10	CC	3.75	12	12	12	12	12	12	12	12	12	12	12	12	12	12
F30	CC	3.75	10	10	5	5	-	-	10	10	10	10	5	5	-	-
F31	CC	3.75	15	15	15	15	-	-	15	15	15	15	15	15	-	-
F57	CC	3.75	-	-	7.5	7.5	4	4	-	-	-	-	7.5	7.5	4	4
F61 <sup>2</sup>	J	3.75	-	-	-	-	-	-	100	100	100	100	50	50	45	40
CB10 <sup>3</sup>	-	3.75	70	60	30	30	25	25	100	100	100	100	50	50	45	40

<sup>1</sup> When SCCR is installed, F4 fuse is Class J.

<sup>2</sup> Fuses F61 are only used on units with SCCR installed.

<sup>3</sup> Units using Circuit Breakers will use CB10 option.

**TABLE 33**

LHT 120 continued																		
Electric Heat Size			22.5 KW								30 KW							
Unit Voltage			208V - 3 Ph		240V - 3 Ph		460V - 3Ph		575V - 3Ph		208V - 3 Ph		240V - 3 Ph		460V - 3Ph		575V - 3Ph	
Power Exhaust Option			W / P.E.	W / O P.E.	W / P.E.	W / O P.E.	W / P.E.	W / O P.E.	W / P.E.	W / O P.E.	W / P.E.	W / O P.E.	W / P.E.	W / O P.E.	W / P.E.	W / O P.E.	W / P.E.	W / O P.E.
Diagram Key	Class	Blower HP	Amps															
F4	RK or K <sup>1</sup> or J	3.75	70	60	70	60	30	30	25	25	70	60	70	60	30	30	25	25
F10	CC	3.75	12	12	12	12	12	12	12	12	12	12	12	12	12	12	12	12
F30	CC	3.75	10	10	10	10	5	5	-	-	10	10	10	10	5	5	-	-
F31	CC	3.75	15	15	15	15	15	15	-	-	15	15	15	15	15	15	-	-
F57	CC	3.75	-	-	-	-	7.5	7.5	4	4	-	-	-	-	7.5	7.5	4	4
F61 <sup>2</sup>	J	3.75	125	110	125	125	60	60	50	50	150	150	150	150	80	70	60	60
CB10 <sup>3</sup>	-	3.75	125	110	125	125	60	60	50	50	150	150	150	150	80	70	60	60

<sup>1</sup> When SCCR is installed, F4 fuse is Class J.

<sup>2</sup> Fuses F61 are only used on units with SCCR installed.

<sup>3</sup> Units using Circuit Breakers will use CB10 option.

**TABLE 34**

LHT 120 continued																		
Electric Heat Size			45 KW								60 KW							
Unit Voltage			208V - 3 Ph		240V - 3 Ph		460V - 3 Ph		575V - 3 Ph		208V - 3 Ph		240V - 3 Ph		460V - 3Ph		575V - 3 Ph	
Power Exhaust Option			W / P.E.	W / O P.E.	W / P.E.	W / O P.E.	W / P.E.	W / O P.E.	W / P.E.	W / O P.E.	W / P.E.	W / O P.E.	W / P.E.	W / O P.E.	W / P.E.	W / O P.E.	W / P.E.	W / O P.E.
Diagram Key	Class	Blower HP	Amps															
F4	RK or K <sup>1</sup> or J	3.75	70	60	70	60	30	30	25	25	70	60	70	60	30	30	25	25
F10	CC	3.75	12	12	12	12	12	12	12	12	12	12	12	12	12	12	12	12
F30	CC	3.75	10	10	10	10	5	5	-	-	10	10	10	10	5	5	-	-
F31	CC	3.75	15	15	15	15	15	15	-	-	15	15	15	15	15	15	-	-
F57	CC	3.75	-	-	-	-	7.5	7.5	4	4	-	-	-	-	7.5	7.5	4	4
F61 <sup>2</sup>	J	3.75	N	N	N	N	100	100	80	80	N	N	N	N	100	100	80	80
CB10 <sup>3</sup>	-	3.75	175	175	200	200	100	100	80	80	200	200	200	200	100	100	80	80

<sup>1</sup> When SCCR is installed, F4 fuse is Class J.

<sup>2</sup> Fuses F61 are only used on units with SCCR installed.

<sup>3</sup> Units using Circuit Breakers will use CB10 option.

**TABLE 35**

LHT 152																		
Electric Heat Size			0 KW						15 KW									
Unit Voltage			208/230V - 3 Ph		460V - 3 Ph		575V - 3 Ph		208V - 3 Ph		240V - 3 Ph		460V - 3 Ph		575V - 3 Ph			
Power Exhaust Option			W / P.E.	W / O P.E.	W / P.E.	W / O P.E.	W / P.E.	W / O P.E.	W / P.E.	W / O P.E.	W / P.E.	W / O P.E.	W / P.E.	W / O P.E.	W / P.E.	W / O P.E.		
Diagram Key	Class	Blower HP	Amps															
F4	RK or K <sup>1</sup> or J	3.75	90	80	40	35	30	30	90	80	90	80	40	35	30	30		
F10	CC	3.75	12	12	12	12	12	12	12	12	12	12	12	12	12	12		
F30	CC	3.75	10	10	5	5	-	-	10	10	10	10	5	5	-	-		
F31	CC	3.75	15	15	15	15	-	-	15	15	15	15	15	15	-	-		
F57	CC	3.75	-	-	7.5	7.5	4	4	-	-	-	-	7.5	7.5	4	4		
F61 <sup>2</sup>	J	3.75	-	-	-	-	-	-	110	110	125	125	60	60	45	45		
CB10 <sup>3</sup>	-	3.75	90	80	40	35	30	30	110	110	125	125	60	60	45	45		

<sup>1</sup> When SCCR is installed, F4 fuse is Class J.

<sup>2</sup> Fuses F61 are only used on units with SCCR installed.

<sup>3</sup> Units using Circuit Breakers will use CB10 option.

**TABLE 36**

LHT 152 continued																		
Electric Heat Size			22.5 KW								30 KW							
Unit Voltage			208V - 3 Ph		240V - 3 Ph		460V - 3Ph		575V - 3Ph		208V - 3 Ph		240V - 3 Ph		460V - 3Ph		575V - 3Ph	
Power Exhaust Option			W / P.E.	W / O P.E.	W / P.E.	W / O P.E.	W / P.E.	W / O P.E.	W / P.E.	W / O P.E.	W / P.E.	W / O P.E.	W / P.E.	W / O P.E.	W / P.E.	W / O P.E.	W / P.E.	W / O P.E.
Diagram Key	Class	Blower HP	Amps															
F4	RK or K <sup>1</sup> or J	3.75	90	80	90	80	40	35	30	30	90	80	90	80	40	35	30	30
F10	CC	3.75	12	12	12	12	12	12	12	12	12	12	12	12	12	12	12	12
F30	CC	3.75	10	10	10	10	5	5	-	-	10	10	10	10	5	5	-	-
F31	CC	3.75	15	15	15	15	15	15	-	-	15	15	15	15	15	15	-	-
F57	CC	3.75	-	-	-	-	7.5	7.5	4	4	-	-	-	-	7.5	7.5	4	4
F61 <sup>2</sup>	J	3.75	150	150	150	150	70	70	60	60	150	150	175	175	80	80	70	60
CB10 <sup>3</sup>	-	3.75	150	150	150	150	70	70	60	60	150	150	175	175	80	80	70	60

<sup>1</sup> When SCCR is installed, F4 fuse is Class J.

<sup>2</sup> Fuses F61 are only used on units with SCCR installed.

<sup>3</sup> Units using Circuit Breakers will use CB10 option.

**TABLE 37**

LHT 152 continued																		
Electric Heat Size			45 KW								60 KW							
Unit Voltage			208V - 3 Ph		240V - 3 Ph		460V - 3 Ph		575V - 3 Ph		208V - 3 Ph		240V - 3 Ph		460V - 3Ph		575V - 3 Ph	
Power Exhaust Option			W / P.E.	W / O P.E.	W / P.E.	W / O P.E.	W / P.E.	W / O P.E.	W / P.E.	W / O P.E.	W / P.E.	W / O P.E.	W / P.E.	W / O P.E.	W / P.E.	W / O P.E.	W / P.E.	W / O P.E.
Diagram Key	Class	Blower HP	Amps															
F4	RK or K <sup>1</sup> or J	3.75	90	80	90	80	40	35	30	30	90	80	90	80	40	35	30	30
F10	CC	3.75	12	12	12	12	12	12	12	12	12	12	12	12	12	12	12	12
F30	CC	3.75	10	10	10	10	5	5	-	-	10	10	10	10	5	5	-	-
F31	CC	3.75	15	15	15	15	15	15	-	-	15	15	15	15	15	15	-	-
F57	CC	3.75	-	-	-	-	7.5	7.5	4	4	-	-	-	-	7.5	7.5	4	4
F61 <sup>2</sup>	J	3.75	N	N	N	N	100	100	80	80	N	N	N	N	110	110	90	90
CB10 <sup>3</sup>	-	3.75	200	200	225	225	100	100	80	80	200	200	225	225	110	110	90	90

<sup>1</sup> When SCCR is installed, F4 fuse is Class J.

<sup>2</sup> Fuses F61 are only used on units with SCCR installed.

<sup>3</sup> Units using Circuit Breakers will use CB10 option

## Field-Installed Accessories

When field-installing the following accessories, refer to the latest online installation instruction.

**TABLE 38**

Accessory	Instruction #
Economizer	507227-XX
Outdoor Air Damper	506340-XX
Electric Heat	507250-XX
Smoke Detector	508468-XX

## Factory Unit Controller Settings

Use the mobile service app to adjust parameters; menu paths are shown in each table. Refer to the Unit Controller manual provided with each unit.

TABLE 39 and TABLE 40 show control options. When applicable, record field-specific information on the label located inside the compressor access panel.

When field installing optional kits and accessories, the Unit Controller must be configured to identify the option before it will function. Refer to FIGURE 51 and FIGURE 52 to determine whether the Unit Controller configuration I.D. must change. To configure the option, use RTU MENU > SETUP > INSTALL menu path. Press NEXT until CONFIGURATION ID 1 or 2 appears depending on the option installed. Change the appropriate character in the configuration I.D. For example, when an economizer is installed using a single enthalpy sensor, change configuration I.D. 1, the second character, to "S".

**TABLE 39**

**581037-01**

### Units With LonTalk Settings

Use menu RTU Menu > Network Integration > Network Setup Wizard > Set "LONTALK"

**TABLE 40**

**581038-01**

### Units With BACnet Settings

RTU Menu > Network Integration > Network Setup Wizard > BACnet MS/TP > See BACnet MAC Address

BACNET MAC ADDRESS:

### Units With Room Sensor, CPC/LSE Gateway Settings

RTU Menu > Network Integration > Network Setup Wizard > SBUS > Set SBUS Address

LCONN ADDRESS:

# Configuration ID 1

1 2 3 4 5 6 7 8

## Humiditrol [1]

Not Installed = **N**  
 Humiditrol Installed = **H**  
 Unconfigured = **U**

## Economizer [2]

Not Installed = **N**  
 Motorized Outdoor Air Damper Only = **M**  
 Economizer - Temperature = **T**  
 Economizer Global = **G**  
 Economizer - Single Enthalpy = **S**  
 Economizer - Dual Enthalpy = **D**  
 Unconfigured = **U**

## Power Exhaust [3]

Not Installed = **N**  
 Single-Stage = **S**  
 Dual-Stage = **D**  
 Unconfigured = **U**

## Power Exhaust Control 4]

Not Installed = **N**  
 Damper Position = **A**  
 A34 Pressure Sensor = **C**

## [8] Outdoor Air Velocity Control

**N** = Not applicable (for future use)  
**L** = Outdoor Air Control Installed with A24 Sensor set for low range.  
**M** = Outdoor Air Control Installed with A24 Sensor set for medium range.  
**H** = Outdoor Air Control Installed with A24 Sensor set for high range.

## [7] System Blower Sub-type

**N** = Not Applicable.  
**L** = ECM Direct Drive Blower with PWM control.  
**H** = EBM Direct Drive Blower with Modbus control.  
**5** = EBM Direct Drive 500mm blower with Modbus control.  
**B** = Mitsubishi Belt Drive blower with Modbus control.  
**D** = Delta Belt Drive blower with Modbus control.

## [6] Blower Variable Frequency Drive Bypass

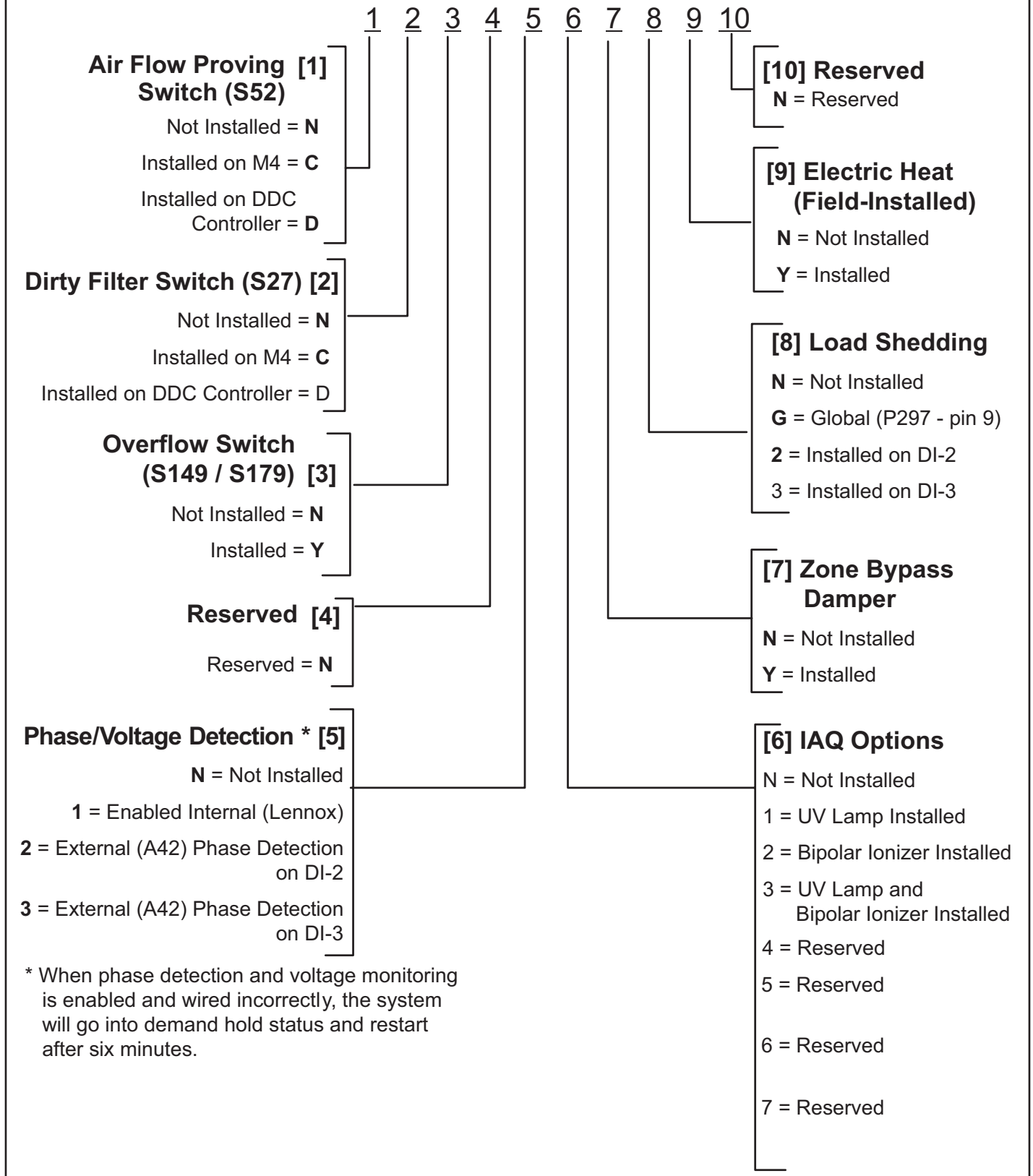
**N** = Not Installed  
**A** = Automatic Bypass  
**M** = Manual Bypass  
**U** = Electronic Bypass Field Unconfigured

## [5] Network Module

**N** = Not Installed  
**L** = LonTalk (Lennox)

FIGURE 51

## Configuration ID 2



**FIGURE 52**

## Decommissioning

Before carrying out this procedure, it is essential that the technician is completely familiar with the equipment and all its detail. It is recommended good practice that all refrigerants are recovered safely.

Prior to the task being carried out, an oil and refrigerant sample shall be taken in case analysis is required prior to re-use of recovered refrigerant. It is essential that electrical power is available before starting decommissioning.

- a) Become familiar with the equipment and its operation.
- b) Isolate system electrically.
- c) Before attempting the procedure, ensure that:
  - mechanical handling equipment is available, if required, for handling refrigerant cylinders;
  - all personal protective equipment is available and being used correctly;
  - the recovery process is supervised at all times by a competent person;
  - recovery equipment and cylinders conform to the appropriate standards.
- d) Pump down refrigerant system, if possible.
- e) If a vacuum is not possible, make a manifold so that refrigerant can be removed from various parts of the system.
- f) Make sure that cylinder is situated on the scales before recovery takes place.
- g) Start the recovery machine and operate in accordance with instructions.
- h) Do not overfill cylinders (no more than 80% volume liquid charge).
- i) Do not exceed the maximum working pressure of the cylinder, even temporarily.
- j) When the cylinders have been filled correctly and the process completed, make sure that the cylinders and the equipment are removed from site promptly and all isolation valves on the equipment are closed off.
- k) Recovered refrigerant shall not be charged into another REFRIGERATING SYSTEM unless it has been cleaned and checked.



## IMPORTANT

Equipment shall be labelled stating that it has been decommissioned and emptied of refrigerant. The label shall be signed and dated. Ensure that there are labels on the equipment that state the flammability of the refrigerant used.

## START-UP REPORT

Job Name: \_\_\_\_\_  
 Store No. \_\_\_\_\_ Start-Up Date: \_\_\_\_\_  
 Address: \_\_\_\_\_  
 City: \_\_\_\_\_ State: \_\_\_\_\_  
 Start-Up Contractor: \_\_\_\_\_  
 Technician: \_\_\_\_\_  
 Model No.: \_\_\_\_\_  
 Serial No.: \_\_\_\_\_  
 RTU No.: \_\_\_\_\_ Catalog No.: \_\_\_\_\_

Inspections and Checks			
Damage?	Yes	No	R454B <input type="checkbox"/>
If yes, reported to: _____			
Verify factory and field-installed accessories.			
Check electrical connections. Tighten if necessary.			
Supply voltage: L1-L2 _____ L1-L3 _____ L2-L3 _____			
If unit contains a 208-230/240 volt transformer:			
Check primary transformer tap <input type="checkbox"/>			
Transformer secondary voltage: _____			

Cooling Checks												
Compressor Rotation <input type="checkbox"/> Ambient Temp. _____ Return Air Temp. _____ Supply Air Temp. _____												
	Compressor Amps			Compressor Volts			Pressures		Condenser Fan Amps			CC Heater Amps
	L1	L2	L3	L1-L2	L1-L3	L2-L3	Disch.	Suct.	L1	L2	L3	L1
1												
2												
3												
4												

Blower Checks			
Pulley/Belt Alignment <input type="checkbox"/>	Blower Rotation <input type="checkbox"/>		
Set Screws Tight <input type="checkbox"/>	Belt Tension <input type="checkbox"/>		
Nameplate Amps: _____		Volts: _____	
Motor	Amps	Volts	
	L1 _____	L1-L2 _____	
	L2 _____	L1-L3 _____	
	L3 _____	L2-L3 _____	

Heating Checks - Electric							
Return Air Temp.: _____ Supply Air Temp.: _____							
Limits Operate: <input type="checkbox"/>							
	Amps						
	L1	L2	L3		L1	L2	L3
1				10			
2				11			
3				12			
4				13			
5				14			
6				15			
7				16			
8				17			
9				18			

Heating Checks - Gas		
Fuel type: Nat. <input type="checkbox"/> LP <input type="checkbox"/> Inlet Pressure: _____ in. w.c.		
Return Air Temp.: _____ Supply Air Temp.: _____		
Altitude: _____ Primary Limits Operate: <input type="checkbox"/>		
CO <sub>2</sub> %: _____		
Gas Valve	Manifold Pressure	
	Low Fire	High Fire
GV1		
GV2		

Accessory Checks	
Power Exhaust Amps	
1 _____	2 _____ None <input type="checkbox"/>
Economizer Operation	
Min. Pos. <input type="checkbox"/>	Motor travel full open/close <input type="checkbox"/>

Control Type