

# INSTALLATION INSTRUCTIONS

## **⚠ IMPORTANT**

Improper installation, adjustment, alteration, service or maintenance can cause property damage, personal injury or loss of life. Installation and service must be performed by a licensed professional HVAC installer or equivalent, service agency, or the gas supplier

### Table of Contents

|   |    |
|---|----|
| General . . . . .                                 | 2  |
| Application Considerations . . . . .              | 2  |
| Dimensions . . . . .                              | 5  |
| Parts Arrangement . . . . .                       | 6  |
| Shipping and Packing List . . . . .               | 7  |
| Requirements . . . . .                            | 7  |
| Unit Support . . . . .                            | 8  |
| Duct Connection . . . . .                         | 9  |
| Rigging Unit for Lifting . . . . .                | 9  |
| Horizontal Air Discharge . . . . .                | 9  |
| Condensate Drains . . . . .                       | 11 |
| Gas Piping (Gas Units) . . . . .                  | 12 |
| Pressure Test Gas Piping (Gas Units). . . . .     | 13 |
| Electrical Connections - Power Supply . . . . .   | 13 |
| Electrical Connections - Control Wiring . . . . . | 14 |
| Mobile Service App . . . . .                      | 16 |
| Blower Operation and Adjustments . . . . .        | 19 |
| Refrigerant Leak Detection System . . . . .       | 23 |
| Cooling Start-Up. . . . .                         | 23 |
| Prognostic & Diagnostic Sensors . . . . .         | 33 |
| Cooling Operation. . . . .                        | 38 |
| Gas Heat Start-Up (LGM). . . . .                  | 39 |
| Gas Heating Operation . . . . .                   | 40 |
| Gas Heating Checks and Adjustments . . . . .      | 41 |

- LGM/LCM036** (3 TON)
- LGM/LCM048** (4 TON)
- LGM/LCM060** (5 TON)
- LGM/LCM074** (6 TON)

### GAS AND COOLING PACKAGED UNITS

508463-02

4/2026

Supersedes 12/2025

## R-454B

|   |    |
|---|----|
| Electric Heat Start-Up (LCM Units) . . . . .      | 43 |
| SCR Electric Heat Controller (LCM Units). . . . . | 43 |
| Hot Gas Reheat Start-Up and Operation . . . . .   | 44 |
| Preventative Maintenance / Repair . . . . .       | 46 |
| Factory Unit Controller Settings . . . . .        | 58 |
| Decommissioning. . . . .                          | 61 |

## **⚠ WARNING**

To prevent serious injury or death:

- 1- **Lock-out, tag-out before performing maintenance.**
- 2- **If system power is required (e.g., smoke detector maintenance), disable power to blower, remove fan belt where applicable, and ensure all controllers and thermostats are set to the OFF position before performing maintenance.**
- 3- **Always keep hands, hair clothing, jewelry, tools, etc., away from moving parts.**

### RETAIN THESE INSTRUCTIONS FOR FUTURE REFERENCES

#### Attention!

Use this QR code to download the mobile service app. Follow the prompts to pair the app with the Unit Controller. Refer to the "Mobile Service App" section in this manual. The QR code is also available in the unit control area.



The app can be downloaded from the appropriate iOS or Android store. Look for the following icon.



## General

The LCM and LGM rooftop units are designed for outdoor installations in both down flow and horizontal configurations. The LCM and LGM units have 4 different cooling capacities, i.e., 3, 4, 5, and 6 tonnages. LCM and LGM units of the same cooling capacity have identical refrigeration circuits. The LCM and LGM may have a factory installed hot gas reheat option for dehumidification (refer to Hot Gas Reheat Section for details).

The LGM units can be configured with one of several gas heating inputs, as well as, either 2 Stage or Modulating Gas Valve. Optional electric heat is available for LCM units.

These instructions are intended as a general guide and do not supersede local codes in any way. Authorities having jurisdiction should be consulted before installation.

## Application Considerations

### CAUTION

As with any mechanical equipment, contact with sharp sheet metal edges can result in personal injury. Take care while handling this equipment and wear gloves and protective clothing.

### WARNING

Only manufacturer approved auxiliary devices are permitted to be installed in this unit.

### WARNING

If this appliance is conditioning a space with an area smaller than T<sub>Amin</sub> or stored in a space with an area smaller than A<sub>min</sub> as defined by this instruction, then that space must be without continuously operating open flames (e.g. an operating gas appliance) or other potential ignition sources (e.g. an operating electric heater or similar hot surface). A flame-producing device may be installed in the same space if the device is provided with an effective flame arrest system.

### WARNING

- Do not use means to accelerate the defrosting process or to clean, other than those recommended by the manufacturer.
- The appliance shall be stored in a room without continuously operating ignition sources (for example: open flames, an operating gas appliance, or an operating electric heater).
- Do not pierce or burn.
- Be aware that refrigerants may not contain an odor.

### CAUTION

Auxiliary devices which may be a potential ignition source shall not be installed in the duct work. Examples of such potential ignition sources are hot surfaces with a temperature exceeding 700°C and electric switching devices.

### CAUTION

Any personnel installing, decommissioning, or performing maintenance on the unit must be properly trained with A2L refrigerants.

### CAUTION

Leak Detection System installed. Unit must be powered except for service.

### CAUTION

This unit should only be installed in locations NOT accessible to the general public.

### CAUTION

Servicing shall be performed only as recommended by the manufacturer.

### WARNING

- This appliance must be installed in accordance with local and national wiring regulations.
- If the appliance is not fitted with an option for full disconnection from power, a means of disconnection must be incorporated in the fixed wiring in accordance with national and local wiring regulations.

### WARNING

Ducts connected to an appliance shall not contain a potential ignition source.

### CAUTION

The appliance is not to be used by persons (including children) with reduced physical, sensory or mental capabilities, or lack of experience and knowledge, unless they have been given supervision or instruction

### CAUTION

Children should be supervised not to play with the appliance.

## **IMPORTANT**

Pipe work, including piping material, pipe routing, and installation shall include protection from physical damage in operation and service, and be in compliance with national and local codes and standards, such as ASHRAE 15, ASHRAE 15.2, IAPMO Uniform Mechanical Code, ICC International Mechanical Code, or CSA B52. All field joints shall be accessible for inspection prior to being covered or enclosed.

## **IMPORTANT**

Refrigerant sensors for refrigerant detection systems shall only be replaced with sensors specified by the appliance manufacture.

## **CAUTION**

This unit is equipped with electrically powered safety measures. To be effective, the unit must be electrically powered at all times after installation, other than when servicing.

### **A-A2L Refrigeration Considerations**

Ensure that the work area is adequately ventilated before breaking into the system or conducting any hot work. A degree of ventilation shall continue during the period that the work is carried out. The ventilation should safely disperse any released refrigerant and preferably expel it externally into the atmosphere.

Check that cabling will not be subject to wear, corrosion, excessive pressure, vibration, sharp edges or any other adverse environmental effects, taking into account the effects of aging or continual vibration from sources such as compressors or fans.

Under no circumstances shall potential sources of ignition be used when searching for or detection of refrigerant leaks. A halide torch (or any other detector using a naked flame) shall not be used. Electronic leak detectors may be used to detect refrigerant leaks but, in the case of flammable refrigerants, the sensitivity may not be adequate, or may need re-calibration. (Detection equipment shall be calibrated in a refrigerant-free area.) Ensure that the detector is not a potential source of

ignition and is suitable for the refrigerant used. Leak detection equipment shall be set at a percentage of the LFL of the refrigerant and shall be calibrated to the refrigerant employed, and the appropriate percentage of gas (25 % maximum) is confirmed. Leak detection fluids are also suitable for use with most refrigerants but the use of detergents containing chlorine shall be avoided as the chlorine may react with the refrigerant and corrode the copper pipe-work. If a leak is suspected, all naked flames shall be removed/extinguished. If a leakage of refrigerant is found which requires brazing, all of the refrigerant shall be recovered from the system, or isolated (by means of shut off valves) in a part of the system remote from the leak.

When breaking into the refrigerant circuit to make repairs – or for any other purpose – conventional procedures shall be used. However, for flammable refrigerants it is important that best practices be followed since flammability is a consideration. The following procedure shall be adhered to:

- Safely remove refrigerant following local and national regulations.
- Evacuate the circuit.
- Purge the circuit with inert gas.
- Evacuate.
- Purge the circuit with inert gas.
- Open the circuit

The refrigerant charge shall be recovered into the correct recovery cylinders if venting is not allowed by local and national codes. For appliances containing flammable refrigerants, the system shall be purged with oxygen-free nitrogen to render the appliance safe for flammable refrigerants. This process might need to be repeated several times. Compressed air or oxygen shall not be used for purging refrigerant systems. Refrigerants purging shall be achieved by breaking the vacuum in the system with oxygen-free nitrogen and continuing to fill until the working pressure is achieved, then venting to atmosphere, and finally pulling down to a vacuum. This process shall be vented down to atmospheric pressure to enable work to take place. Ensure that the outlet for the vacuum pump is not close to any potential ignition sources and that ventilation is available.

## B-Minimum R454B Space and CFM Requirements

| Minimum Airflow <sup>1</sup> |                        |                                     |
|------------------------------|------------------------|-------------------------------------|
| Unit                         | Q <sub>min</sub> (CFM) | Q <sub>min</sub> (m <sup>3</sup> h) |
| LCM/LGM036                   | 500                    | 850                                 |
| LCM/LGM048                   | 500                    | 850                                 |
| LCM/LGM060                   | 500                    | 850                                 |
| LCM/LGM074                   | 500                    | 850                                 |
| LCM/LGM036 W/ Humidrol       | 500                    | 850                                 |
| LCM/LGM048 W/ Humidrol       | 500                    | 850                                 |
| LCM/LGM060 W/ Humidrol       | 500                    | 850                                 |
| LCM/LGM074 W/ Humidrol       | 500                    | 850                                 |

<sup>1</sup> **NOTE** - The minimum airflow is the lowest CFM allowed during venting operation (leak mitigation).

| Minimum Room Area of Conditioned Space <sup>2</sup> |                                      |                                     |
|---|--------------------------------------|-------------------------------------|
| Unit  | TA <sub>min</sub> (ft <sup>2</sup> ) | TA <sub>min</sub> (m <sup>2</sup> ) |
| LCM/LGM036  | 46.73                                | 4.34                                |
| LCM/LGM048  | 75.44                                | 7.01                                |
| LCM/LGM060  | 71.19                                | 6.61                                |
| LCM/LGM074  | 70.31                                | 6.53                                |
| LCM/LGM036 W/ Humidrol                              | 78.52                                | 7.29                                |
| LCM/LGM048 W/ Humidrol                              | 76.17                                | 7.08                                |
| LCM/LGM060 W/ Humidrol                              | 70.02                                | 6.51                                |
| LCM/LGM074 W/ Humidrol                              | 66.07                                | 6.14                                |

<sup>2</sup> **NOTE** - The minimum room area of conditioned space is the smallest area the unit can service.

| Altitude Adjustment Factor <sup>3</sup> |      |      |      |      |      |      |      |      |      |
|---|------|------|------|------|------|------|------|------|------|
| Halt                                    | 0    | 200  | 400  | 600  | 800  | 1000 | 1200 | 1400 | 1600 |
| AF                                      | 1    | 1    | 1    | 1    | 1.02 | 1.05 | 1.07 | 1.1  | 1.12 |
| Halt                                    | 1600 | 1800 | 2000 | 2200 | 2400 | 2600 | 2800 | 3000 | 3200 |
| AF                                      | 1.12 | 1.15 | 1.18 | 1.21 | 1.25 | 1.28 | 1.32 | 1.36 | 1.4  |

<sup>3</sup> **NOTE** - Use the Altitude Adjustment Factor to adjust the values in the tables above to different altitudes. Find the relevant altitude above sea level in the two "Halt" rows and then multiply the value needed from the tables above by the altitude factor number. Example: For the minimum airflow in CFM for an LCM/LGM036 at 1000 ft. above sea level, multiply 500 by 1.05 to get 525 CFM as the new Q<sub>min</sub>.

## C-Caution Regarding Operation During Construction

Use of this unit as a construction heater or air conditioner is not recommended during any phase of construction. Very low return air temperatures, harmful vapors and operation of the unit with clogged or misplaced filters will damage the unit.

If this unit has been used for heating or cooling of buildings or structures under construction, the following conditions must be met or the warranty will be void:

- A room thermostat must control the unit. The use of fixed jumpers that will provide continuous heating or cooling is not allowed.
- A pre-filter must be installed at the entry to the return air duct.
- The return air duct must be provided and sealed to the unit.
- Return air temperature range between 55°F (13°C)

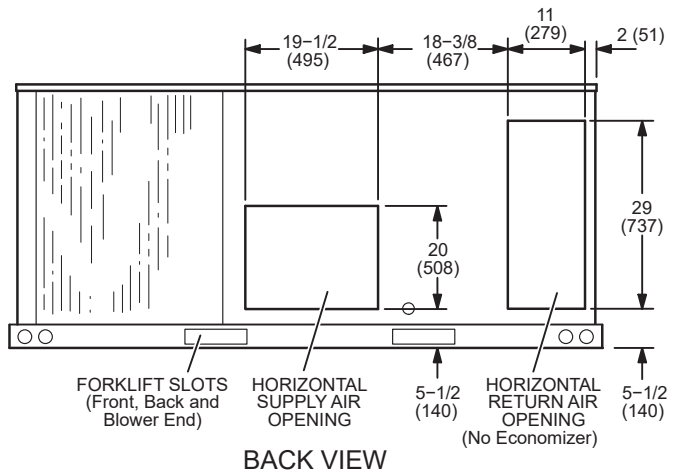
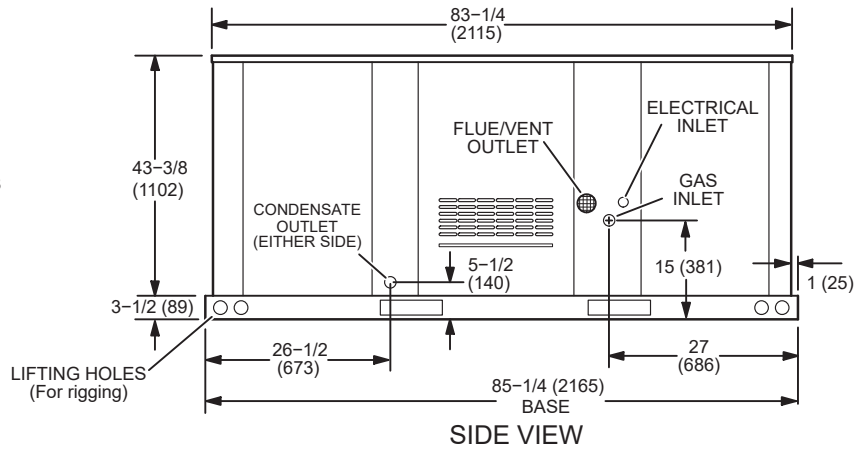
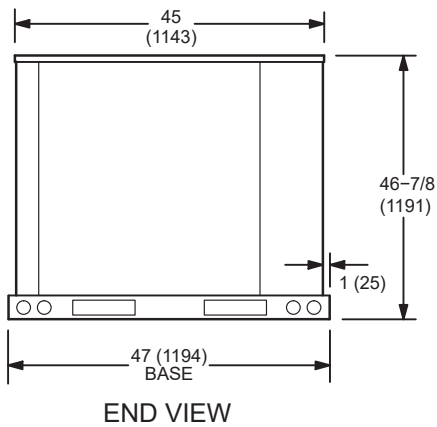
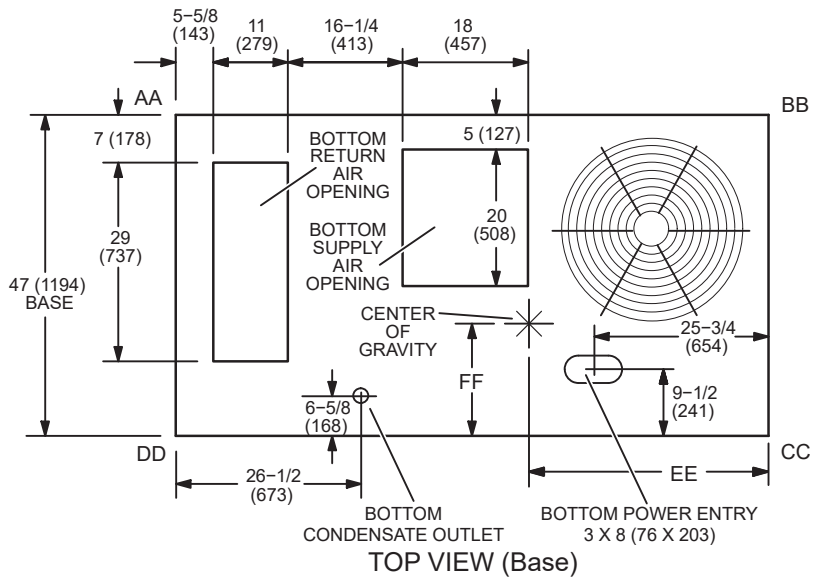
and 80°F (27°C) must be maintained.

- Air filters must be replaced and pre-filters must be removed upon construction completion.
- The input rate and temperature rise must be set per the unit rating plate.
- The heat exchanger, components, duct system, air filters and evaporator coil must be thoroughly cleaned following final construction clean-up.
- The unit operating conditions (including airflow, cooling operation, ignition, input rate, temperature rise and venting) must be verified according to these installation instructions.

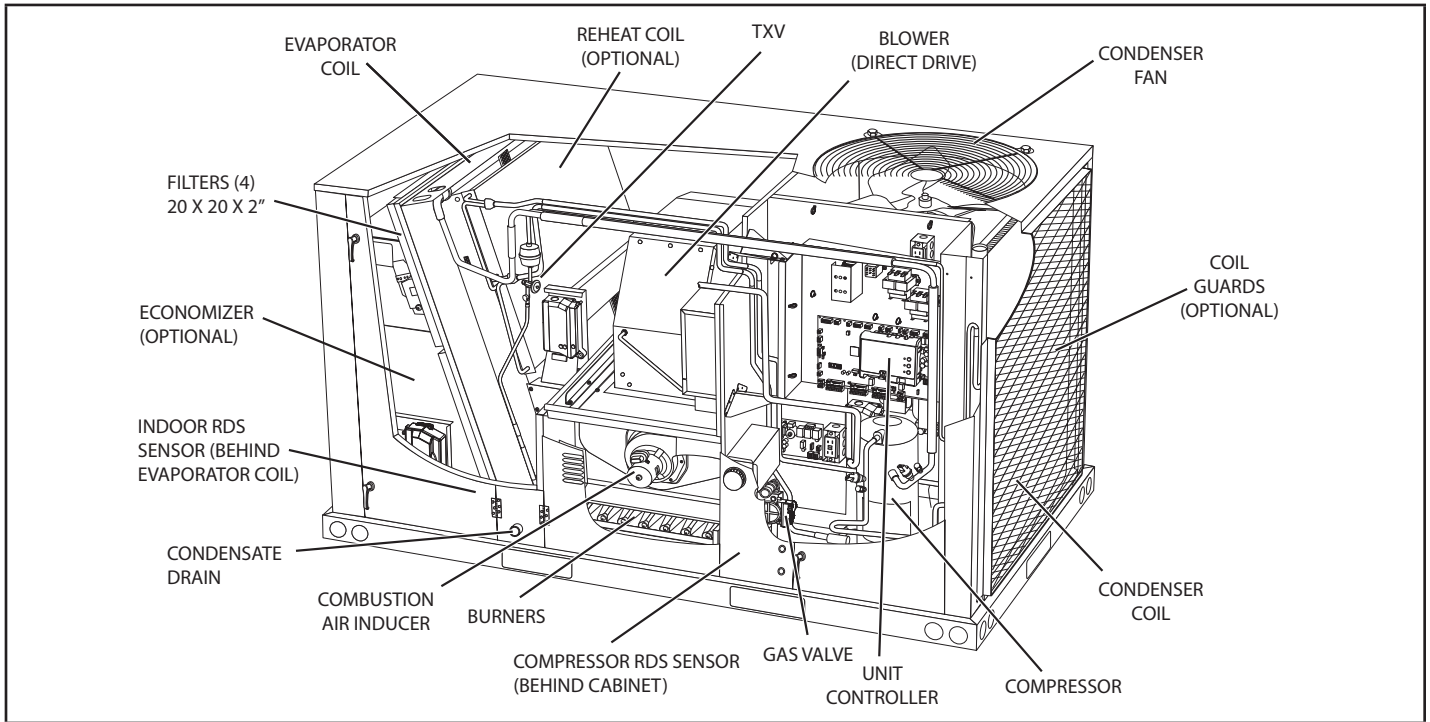
This appliance is not intended for use by persons (including children) with reduced physical, sensory, or mental capabilities, or lack of experience and knowledge, unless they have been given supervision or instruction concerning use of the appliance by a person responsible for their safety.

| Refrigerant Charge R-454B |                      |                     |
|---------------------------|----------------------|---------------------|
| Unit                      | M <sub>c</sub> (lbs) | M <sub>c</sub> (kg) |
| LCM/LGM036                | 4.50                 | 2.0412              |
| LCM/LGM048                | 5.0625               | 2.2963              |
| LCM/LGM060                | 5.0625               | 2.2963              |
| LCM/LGM074                | 5.0625               | 2.2963              |
| LCM/LGM036 W/ Humidrol    | 5.6875               | 2.5798              |
| LCM/LGM048 W/ Humidrol    | 5.5625               | 2.5231              |
| LCM/LGM060 W/ Humidrol    | 5.5625               | 2.5231              |
| LCM/LGM074 W/ Humidrol    | 5.5625               | 2.5231              |

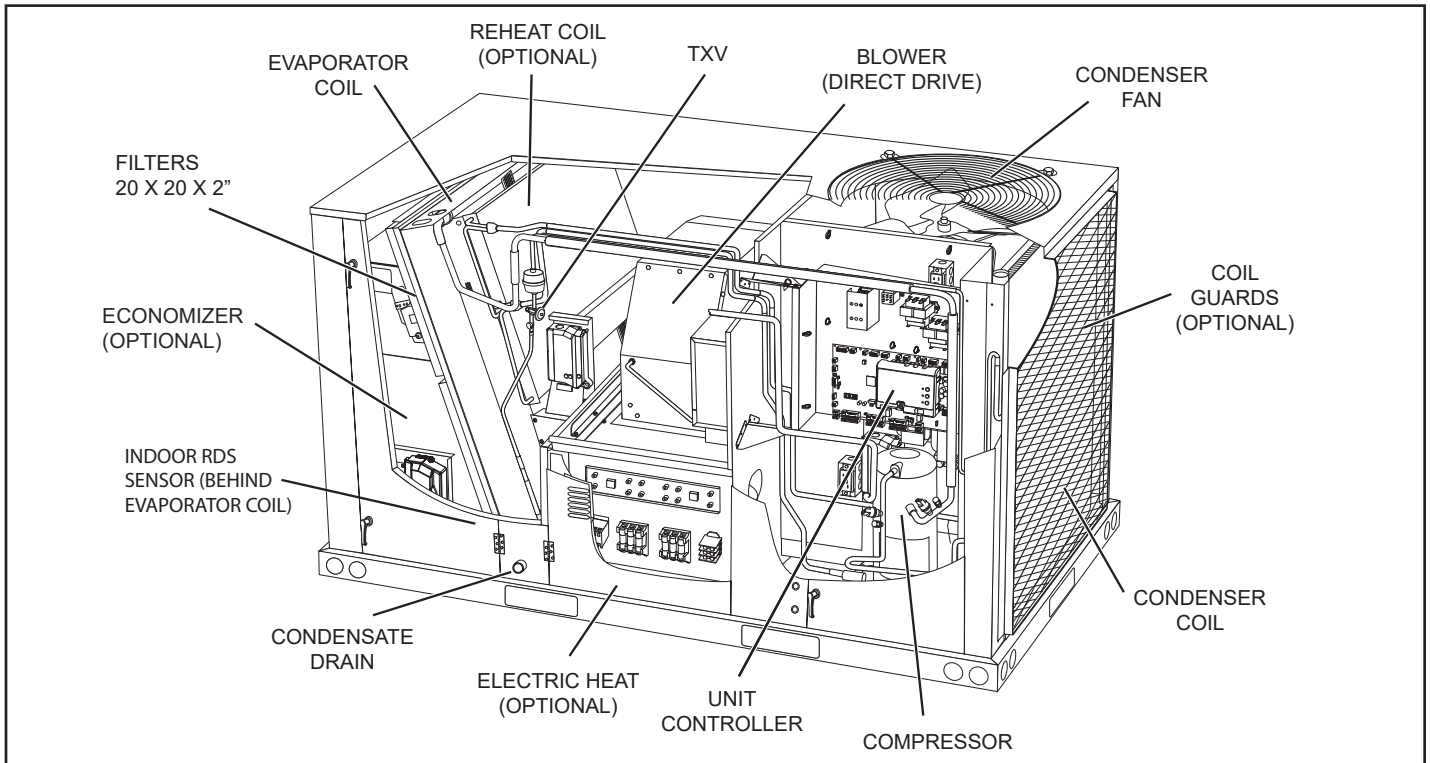
**LGM/LCM036, 048, 060, 074 Dimensions in. - Gas heat section shown**



## LGM036, 048, 060, & 074 Parts Arrangement



## LCM036, 048, 060, & 074 Parts Arrangement



## Shipping and Packing List

### Package 1 of 1 contains:

- 1 - Assembled unit

Check unit for shipping damage. Receiving party should contact last carrier immediately if shipping damage is found.

### Top Cap Packaging

Once lumber, bracket, and screws have been removed from the top of the unit, replace the screws in the corners of the cabinet. See FIGURE 2.

## Requirements

See FIGURE 1 for unit clearances.

## IMPORTANT

The Clean Air Act of 1990 bans the intentional venting of refrigerant (CFC's and HCFC's) as of July 1, 1992. Approved methods of recovery, recycling or reclaiming must be followed. Fines and/or incarceration may be levied for non-compliance.

## WARNING



Electric shock hazard and danger of explosion. Can cause injury, death or product or property damage. Turn off gas and electrical power to unit before performing any maintenance or servicing operations on the unit. Follow lighting instructions attached to unit when putting unit back into operation and after service or maintenance.

## NOTICE

### Roof Damage!

This system contains both refrigerant and oil. Some rubber roofing material may absorb oil, causing the rubber to swell. Bubbles in the rubber roofing material can cause leaks. Protect the roof surface to avoid exposure to refrigerant and oil during service and installation. Failure to follow this notice could result in damage to roof surface.

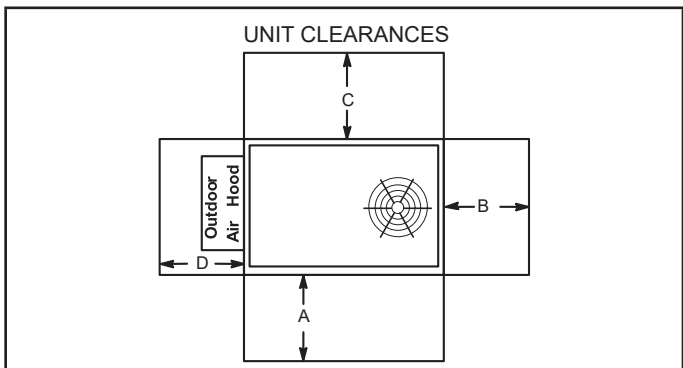


FIGURE 1

| <sup>1</sup> Unit Clearance | A in. (mm) | B in. (mm) | C in. (mm) | D in. (mm) | Top Clearance |
|-----------------------------|------------|------------|------------|------------|---------------|
| Service Clearance           | 48 (1219)  | 36 (914)   | 36 (914)   | 36 (914)   | Unobstructed  |
| Clearance to Combustibles   | 36 (914)   | 1 (25)     | 1 (25)     | 1 (25)     | Unobstructed  |
| Minimum Operation Clearance | 36 (914)   | 36 (914)   | 36 (914)   | 36 (914)   | Unobstructed  |

**NOTE** - Entire perimeter of unit base requires support when elevated above mounting surface.

- <sup>1</sup> Service Clearance - Required for removal of serviceable parts.
- Clearance to Combustibles - Required clearance to combustible material (gas units). On LCM units, see clearance to combustible materials as outlined on heater rating plate.
- Minimum Operation Clearance - Required clearance for proper unit operation.

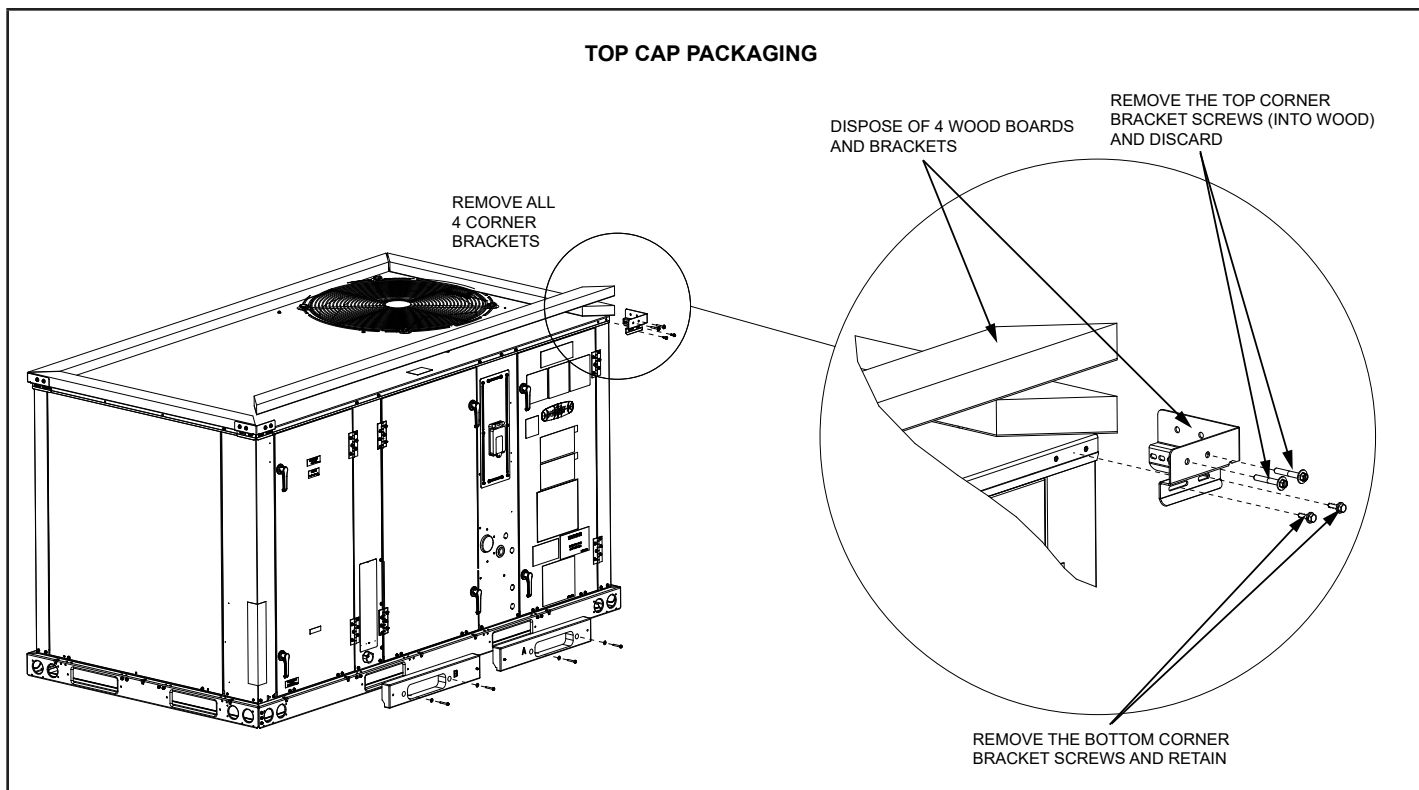


FIGURE 2

### Unit Support

In downflow discharge installations, install the unit on a non-combustible surface only. Unit may be installed on combustible surfaces when used in horizontal discharge applications or in downflow discharge applications when installed on an T1CURB / C1CURB / E1CURB roof mounting frame.

**NOTE** - Securely fasten roof frame to roof per local codes

### ⚠ CAUTION

To reduce the likelihood of supply / return air by pass and promote a proper seal with the RTU, duct work / duct drops / diffuser assemblies must be supported independently to the building structure.

#### A-Downflow Discharge Application

##### Roof Mounting with T1CURB / C1CURB / E1CURB

- 1 - The roof mounting frame must be installed, flashed and sealed in accordance with the instructions provided with the frame.
- 2 - The roof mounting frame should be square and level to 1/16" per linear foot (5mm per linear meter) in any direction.
- 3 - Duct must be attached to the roof mounting frame and not to the unit; supply and return plenums must be installed before setting the unit.

### Installer's Roof Mounting Frame

Many types of roof frames can be used to install the unit depending upon different roof structures. Items to keep in mind when using the building frame or supports are:

- 1 - The base is fully enclosed and insulated, so an enclosed frame is not required.
- 2 - The frames or supports must be constructed with non-combustible materials and should be square and level to 1/16" per linear foot (5mm per linear meter) in any direction.
- 3 - Frame or supports must be high enough to prevent any form of moisture from entering unit. Recommended minimum frame height is 14" (356mm).
- 4 - Duct must be attached to the roof mounting frame and not to the unit. Supply and return plenums must be installed before setting the unit.
- 5 - Units require support along all four sides of unit base. Supports must be constructed of steel or suitably treated wood materials.

**NOTE** - When installing a unit on a combustible surface for downflow discharge applications, a T1CURB / C1CURB / E1CURB roof mounting frame is required.

## B-Horizontal Discharge Applications

- 1 - Units which are equipped with an optional economizer and installed in horizontal airflow applications must use a horizontal conversion kit.
- 2 - Specified installation clearances must be maintained when installing units. Refer to FIGURE 1.
- 3 - Top of support slab should be approximately 4" (102mm) above the finished grade and located so no run-off water from higher ground can collect around the unit.
- 4 - Units require support along all four sides of unit base. Supports must be constructed of steel or suitably treated wood materials.

### Duct Connection

All exterior ducts, joints and openings in roof or building walls must be insulated and weather-proofed with flashing and sealing compounds in accordance with applicable codes. Any duct passing through an unconditioned space must be insulated.

False ceilings or drop ceiling may be used as a return air plenum only if the unit being installed has a Refrigerant Detection System installed.

## **⚠ CAUTION**

In downflow applications, do not drill or punch holes in base of unit. Leaking in roof may occur if unit base is punctured.

### Rigging Unit for Lifting

Rig unit for lifting by attaching four cables to holes in unit base rail. See FIGURE 3.

- 1 - Detach wooden base protection before rigging.
- 2 - Remove all six base protection brackets before setting unit.
- 3 - Connect rigging to the unit base using both holes in each corner.
- 4 - All panels must be in place for rigging.
- 5 - Place field-provided H-style pick in place just above top edge of unit. Frame must be of adequate strength and length. (H-style pick prevents damage to unit.)

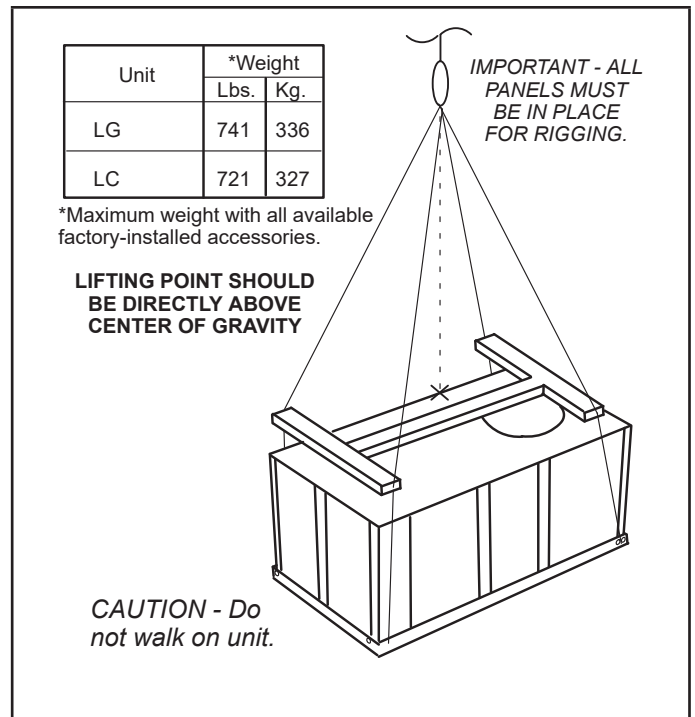


FIGURE 3

### Horizontal Air Discharge

All units are shipped with panels covering the horizontal supply and return air openings.

#### A-Horizontal Discharge - All Units except Modulating Gas Units

- 1 - Remove the horizontal covers from the rear of the unit. Refer to FIGURE 5.
- 2 - Place the horizontal supply and return cover over the base openings.
- 3 - Secure in place with sheet metal screws.

#### B-Horizontal Discharge - Modulating Gas Units

- 1 - Remove the horizontal covers from the rear of the unit. Refer to FIGURE 5.
- 2 - Place the horizontal return air cover over the return air base opening. Secure in place with screws.
- 3 - In the supply air section, the long copper tube must be removed from the unit before proceeding. Refer to FIGURE 4.

## REMOVE PIPING

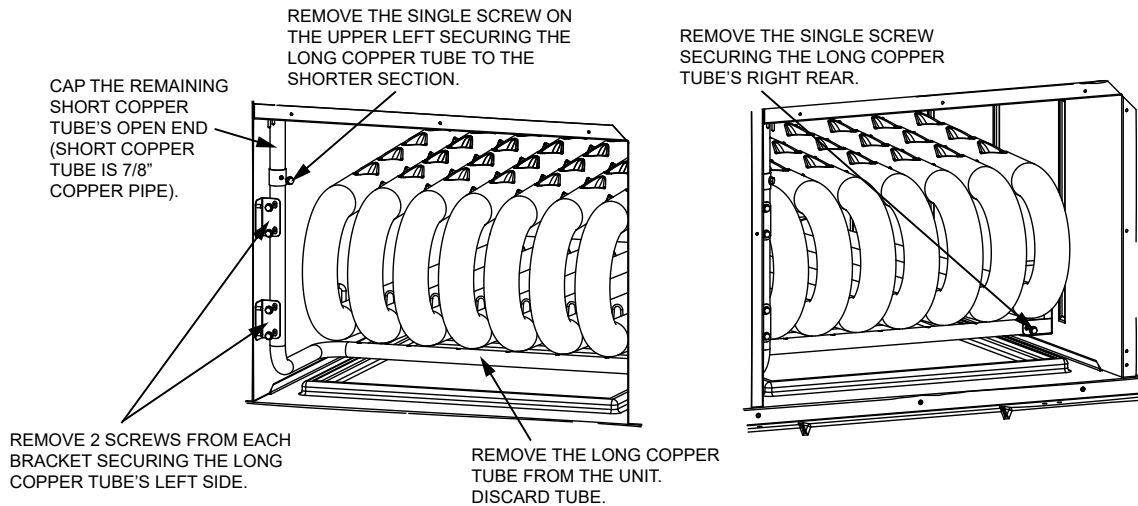


FIGURE 4

**NOTE** - The tube's brackets should remain installed. If brackets are removed, at a minimum, screws originally securing brackets to unit should be reinstalled to eliminate holes.

- Remove the single screw securing the long copper tube's right rear.
- Remove 2 screws from each bracket securing the long copper tube's left side.
- Remove the single screw on the upper left securing the long copper tube to the shorter section.
- Remove the long copper tube from the unit. Discard tube.
- Cap the remaining short copper tube's open end (short copper tube is 7/8" copper pipe).

- Place the horizontal supply air cover over the supply base opening. Secure with screws.

### C-Units Equipped With An Optional Economizer

- Remove the horizontal supply air cover and position over the downflow supply air opening. Secure with sheet metal screws.
- Leave the horizontal return air cover in place.
- Locate the separately ordered horizontal air discharge kit. Place the kit panel over the downflow return air opening.
- Remove and retain the barometric relief dampers and lower hood.

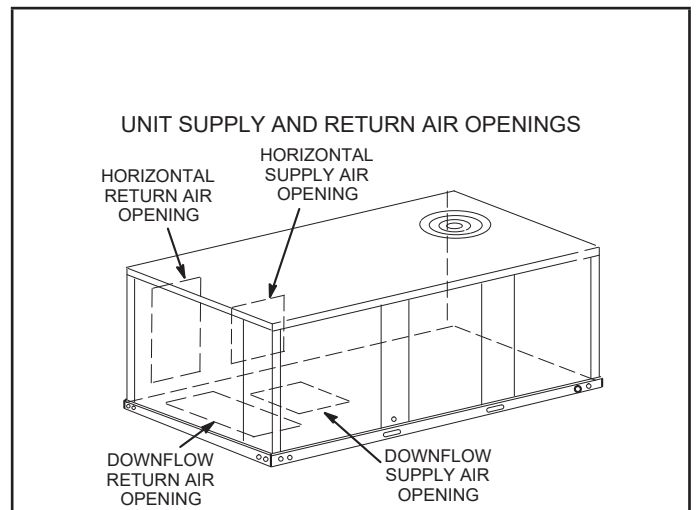


FIGURE 5

- Install return air duct beneath outdoor air intake. See FIGURE 6. Install barometric relief damper in lower hood and install in ductwork as shown in FIGURE 6.

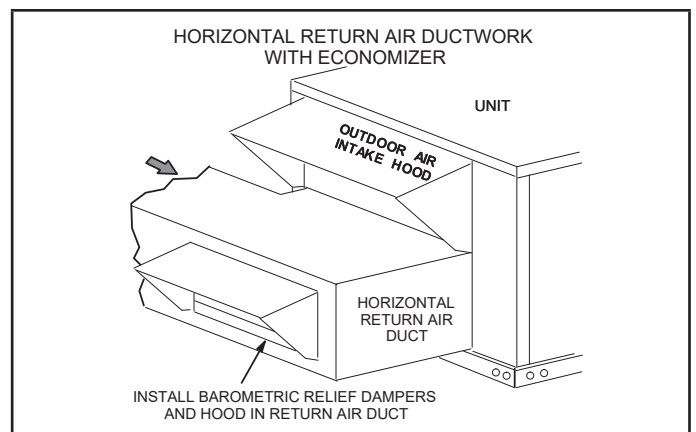


FIGURE 6

## Condensate Drains

Make drain connection to the drain coupling provided on unit. Older model units have a 3/4" N.P.T. coupling and newer model units have a 1" N.P.T. coupling.

**NOTE** - The drain pan is made with a glass reinforced engineered plastic capable of withstanding typical joint torque but can be damaged with excessive force. Tighten pipe nipple hand tight and turn an additional quarter turn.

A trap must be installed between drain connection and an open vent for proper condensate removal. See FIGURE 7 or FIGURE 8. It is sometimes acceptable to drain condensate onto the roof or grade; however, a tee should be fitted to the trap to direct condensate downward. The condensate line must be vented. Check local codes concerning condensate disposal. Refer to page 2 and page 3 for condensate drain location.

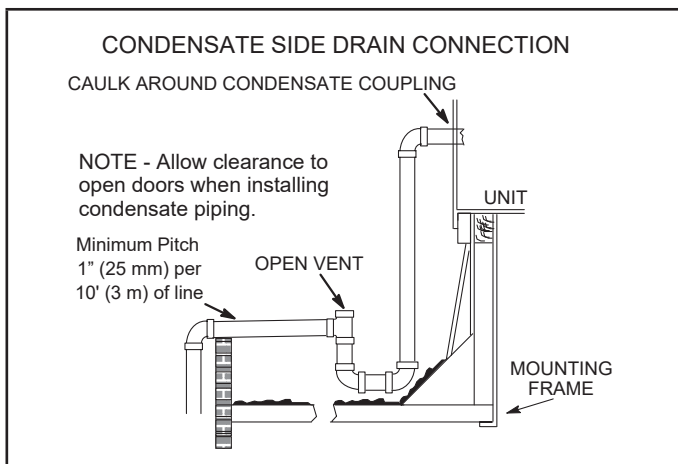


FIGURE 7

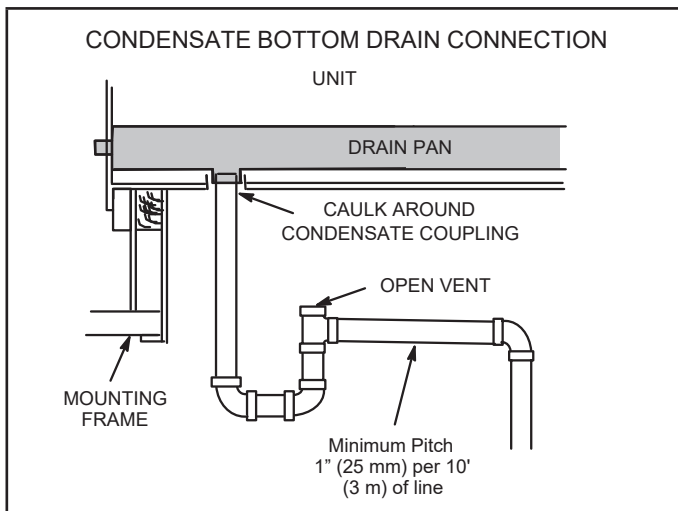


FIGURE 8

Units are shipped with the drain coupling facing the front of the unit. Condensate can be drained from the back or bottom of the unit with the following modifications. The unit can be installed in either downflow or horizontal air discharge regardless of condensate drain location.

## Rear Drain Connection

- 1 - Remove the condensate drain mullion. See FIGURE 9. Remove the two panels on each side of the mullion.

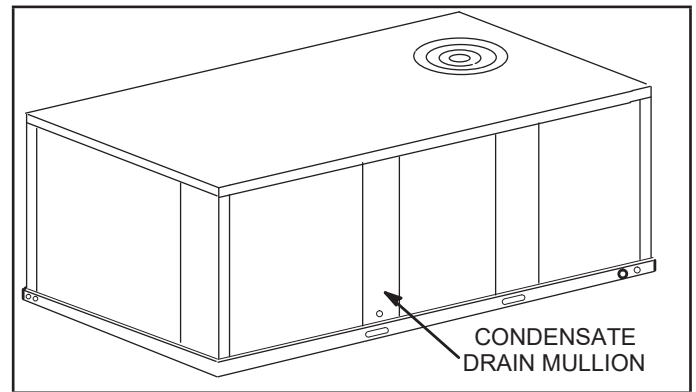


FIGURE 9

- Two hinge screws must be removed in addition to the mullion screws. See FIGURE 10.

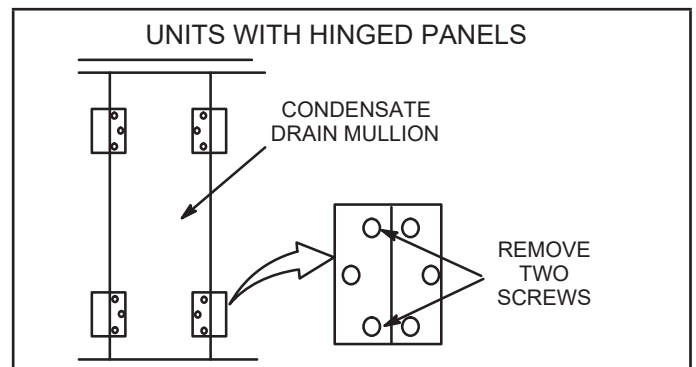


FIGURE 10

- 2 - Lift the front edge of the drain pan and slide pan out of unit. See FIGURE 11.

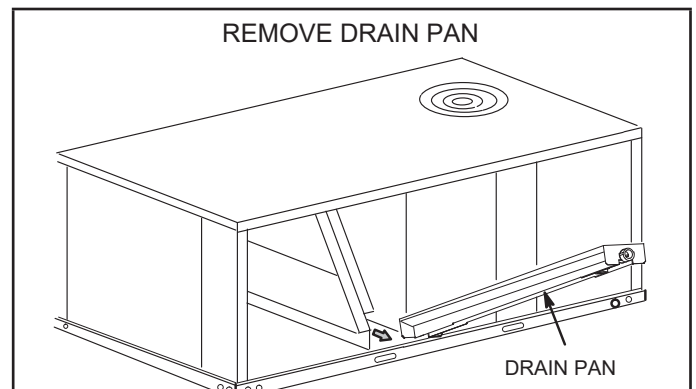


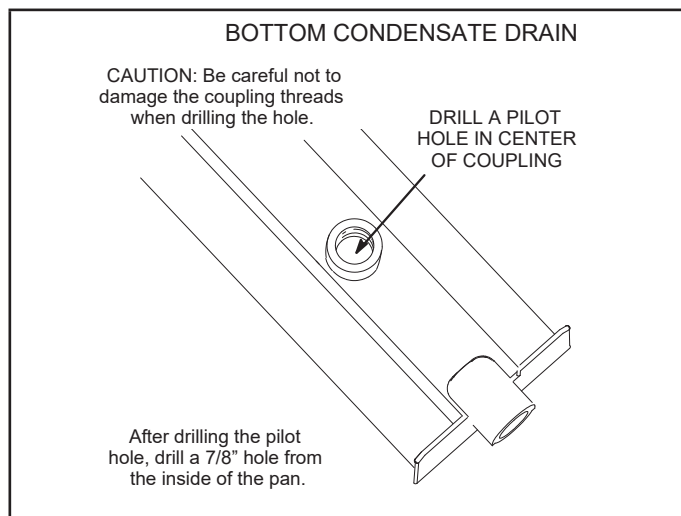
FIGURE 11

- 3 - Make sure the cap over the unit bottom drain hole is secure.
- 4 - Rotate the drain pan until the downward slope is toward the back of the unit. Slide the drain pan back into the unit. Be careful not to dislodge the cap over the bottom drain hole.

- 5 - From the back side of the unit, pull the drain pan coupling through the rear condensate opening.
- 6 - Replace the condensate drain mullion.

### Bottom Drain Connection

- 1 - Remove the condensate drain mullion. See FIGURE 9.
- 2 - Lift the front edge of the drain pan and slide pan out of unit. See FIGURE 11.
- 3 - Turn the drain pan upside down and drill a pilot hole through the bottom of the drain pan in the center of the coupling. See FIGURE 12.



**FIGURE 12**

- 4 - From the inside of the pan, use a Vari-Bit® bit to enlarge the hole to 7/8". Do not damage coupling threads.
- 5 - Remove the cap over the unit bottom drain hole.
- 6 - Slide the drain pan back into the unit.
- 7 - From the back side of the unit, pull the drain pan coupling through the rear condensate opening.
- 8 - From the front side of the unit, move the drain pan until the bottom coupling settles into the unit bottom drain opening. Once in place, check to make sure the coupling is still positioned through the rear condensate drain hole.
- 9 - Use a field-provided 3/4" plug to seal side drain connection.
- 10 - Replace the condensate drain mullion.

### Gas Piping (Gas Units)

Before connecting field-provided piping, check with gas company or authorities having jurisdiction for local code requirements. When installing gas supply piping, length of run from gas meter must be considered in determining pipe size for 0.5" w.c. (.12kPa) maximum pressure drop. Do not use supply pipe smaller than unit gas connection. Operating pressures at the unit gas connection must be as shown in TABLE 1.

**TABLE 1  
OPERATING PRESSURE AT GAS CONNECTION**

|         | w.c.        |      |                  |      |
|---------|-------------|------|------------------|------|
|         | Natural Gas |      | LP / Propane Gas |      |
|         | Min.        | Max. | Min.             | Max. |
| 036/074 | 4.5         | 10.5 | 11               | 13   |

When making piping connections a drip leg should be installed on vertical pipe runs to serve as a trap for sediment or condensate. Refer to Heating Start-Up section for details regarding measurement of gas supply pressure at the unit. Install a ground joint union between the gas control manifold and the main manual shut-off valve. See FIGURE 13 for gas supply piping entering outside the unit. FIGURE 14 shows complete bottom gas entry piping.

Compounds used on threaded joints of gas piping shall be resistant to the action of liquefied petroleum gases.

Do not use Teflon® tape to seal gas piping. Use a moderate amount of pipe compound on the gas pipe only. Make sure the two end threads are bare.

**⚠ CAUTION**

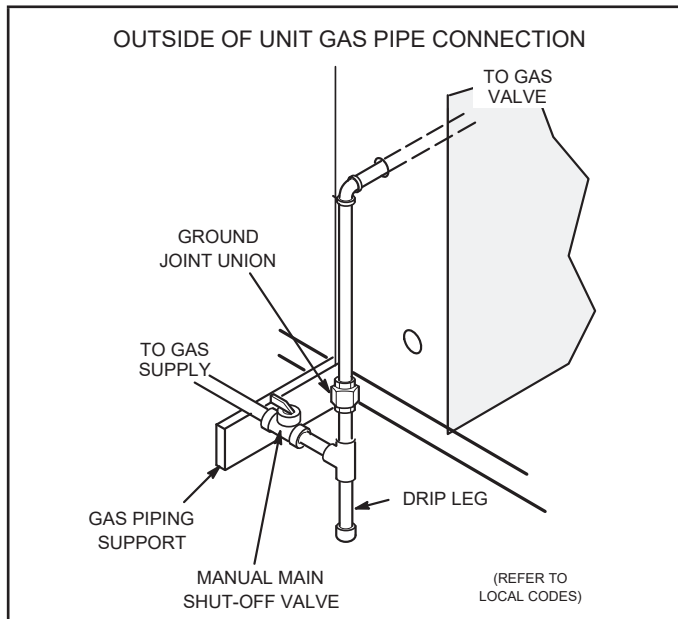
If a flexible gas connector is required or allowed by the authority that has jurisdiction, black iron pipe shall be installed at the gas valve and extend out side the furnace cabinet.

**⚠ WARNING**

Do not exceed 600 in-lbs (50 ft.-lbs) torque when attaching the gas piping to the gas valve.

**⚠ IMPORTANT**

Compounds used on threaded joints of gas piping must be resistant to the actions of liquefied petroleum gases.



**FIGURE 13**

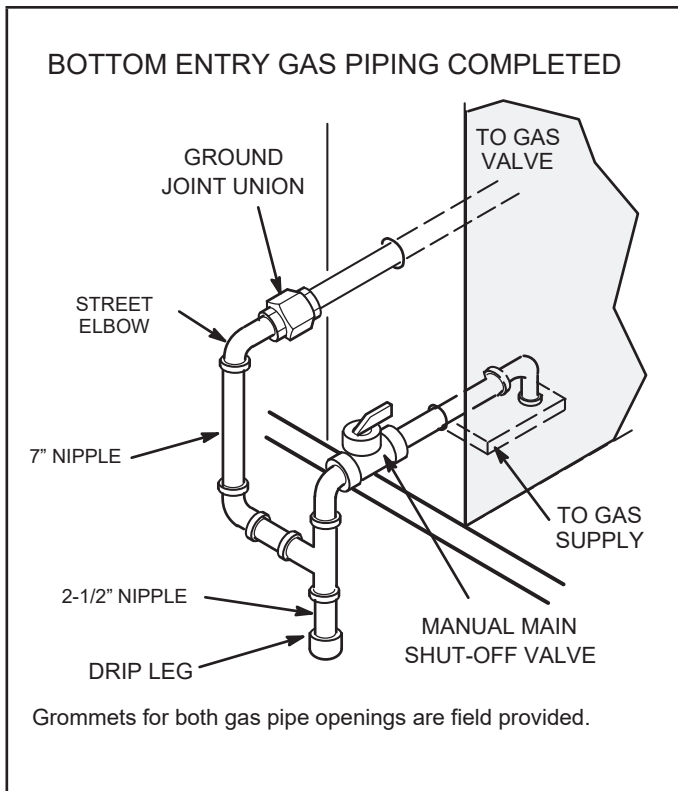


FIGURE 14

### Pressure Test Gas Piping (Gas Units)

When pressure testing gas lines, the gas valve must be disconnected and isolated. Gas valves can be damaged if subjected to more than 0.5 psig (3.48kPa). See FIGURE 15.

**NOTE** - Codes may require that manual main shut-off valve and union (furnished by installer) be installed in gas line external to unit. Union must be of the ground joint type.

After all connections have been made, check all piping connections for gas leaks. Also check existing unit gas connections up to the gas valve; loosening may occur during installation. Use a leak detection solution or other preferred means. Do not use matches candles or other sources of ignition to check for gas leaks.

## ⚠ CAUTION

Some soaps used for leak detection are corrosive to certain metals. Carefully rinse piping thoroughly after leak test has been completed. Do not use matches, candles, flame or other sources of ignition to check for gas leaks.

## ⚠ WARNING



**Danger of explosion. Can cause injury or product or property damage. Do not use matches, candles, flames, or other sources of ignition to check for leaks.**

**NOTE** - In case emergency shut down is required, turn off the main manual shut-off valve and disconnect main power to unit. These devices should be properly labeled by the installer.

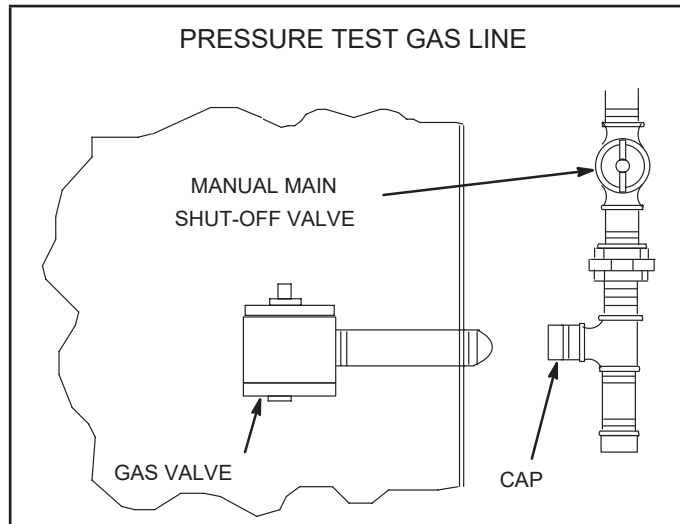


FIGURE 15

### Electrical Connections - Power Supply

Do not apply power or close disconnect switch until installation is complete. Refer to start-up directions. Refer closely to unit wiring diagram.

Refer to unit nameplate for minimum circuit ampacity and maximum fuse size.

- 1 - Units are factory-wired for 230 / 460 / 575 volt supply. For 208V supply, remove the insulated terminal cover from the 208V terminal on the control transformer. Move the wire from the transformer 240V terminal to the 208V terminal. Place the insulated terminal cover on the unused 240V terminal.
- 2 - Route power through the bottom power entry area and connect to L1, L2, and L3 on the top of K1 in control area above compressor. Secure power wiring with factory-installed wire ties provided in control box. Route power to TB2 on units equipped with electric heat. Route power to S48 or CB10 if unit is equipped with the optional disconnect switch or circuit breaker. See unit wiring diagram.

## Electrical Connections - Control Wiring

Connect either a thermostat, room/zone sensor, or direct digital controller; one of the three are required for unit function. Refer to the literature provided with each device and the following information.

**NOTE** - *Optional wireless sensors are available for use with this unit.*

### CAUTION

Electrostatic discharge can affect electronic components. Take precautions during unit installation and service to protect the electronic controls. Precautions will help to avoid control exposure to electrostatic discharge by putting the unit, the control and the technician at the same electrostatic potential. Neutralize electrostatic charge by touching hands and all tools on an unpainted unit surface, such as the gas valve or blower deck, before performing any service procedure.

#### A-Thermostat Location

Room thermostat mounts vertically on a standard 2" X 4" handy box or on any non-conductive flat surface.

Locate thermostat approximately 5 feet (1524mm) above the floor in an area with good air circulation at average temperature. Avoid locating the room thermostat where it might be affected by:

- Drafts or dead spots behind doors and in corners
- Hot or cold air from ducts
- Radiant heat from sun or appliances
- Concealed pipes and chimneys

#### B-Control Wiring

The Unit Controller will operate the unit from a thermostat or zone sensor based on the System Mode. The default System Mode is the thermostat mode. Refer to the Unit Controller Setup Guide to change the System Mode. Use the mobile service app menu and select Settings > Install.

##### Thermostat Mode

- 1 - Route thermostat cable or wires from subbase to control area above compressor (refer to unit dimensions to locate bottom and side power entry).

**IMPORTANT** - *Unless field thermostat wires are rated for maximum unit voltage, they must be routed away from line voltage wiring. Use wire ties located near the lower left corner of the controls mounting panel to secure thermostat cable.*

Use 18 AWG wire for all applications using remotely installed electro-mechanical and electronic thermostats.

- 2 - Install thermostat assembly in accordance with instructions provided with thermostat.

- 3 - Connect thermostat wiring to Unit Controller on the lower side of the controls hat section. Wire as shown in FIGURE 15 for electro-mechanical and electronic thermostats. If using other temperature control devices or energy management systems see instructions and wiring diagram provided by manufacturer.

**IMPORTANT** - *Terminal connections at the wall plate or subbase must be made securely. Loose control wire connections may allow unit to operate but not with proper response to room demand.*

##### Zone Sensor Mode

The Unit Controller will operate heating and cooling based on the Unit Controller internal setpoints and the temperature from the A2 zone sensor. An optional Network Control Panel (NCP) can also be used to provide setpoints. A thermostat or return air sensor can be used as a back-up mode. Make zone sensor wiring connections as shown in FIGURE 16.

#### C-Hot Gas Reheat

- 1 - Install humidity sensor in accordance with instructions provided with sensor. A DDC input may be used to initiate dehumidification instead of a sensor.
- 6 - See FIGURE 16 for wiring connections on Thermostat Mode, Zone Sensor Mode, Humidity Sensor, and Dehumidification Input.

##### Humidity Sensor Cable Applications

###### Wire runs of 50 feet (15 m) or less:

Use two separate shielded cables containing 20AWG minimum, twisted pair conductors with overall shield. Belden type 8762 or 88760 (plenum) or equivalent. Connect both cable shield drain wires to the Unit Controller as shown in FIGURE 16.

###### Wire runs of 150 feet (46 m) or less:

Use two separate shielded cables containing 18AWG minimum, twisted pair conductors with overall shield. Belden type 8760 or 88760 (plenum) or equivalent. Connect both cable shield drain wires to the Unit Controller as shown in FIGURE 16.

###### Wire runs over 150 feet (46 m):

Use a local, isolated 24VAC transformer such as Lennox cat #18M13 (20VA minimum) to supply power to RH sensor as shown in FIGURE 16. Use two shielded cables containing 20AWG minimum, twisted pair conductors with overall shield. Belden type 8762 or 88760 (plenum) or equivalent.



538078-02

01

**A173**  
CTRL SMOKE  
DETECT

02

**A171**  
RA SENSOR

03

**A172**  
SA SENSOR

04

**A55**  
MAIN CTRL

05

**A91**  
HUMID SENSOR

06

**K27**  
RELAY COIL

07

**S86**  
DEHUMIDISTAT

08

**K55**  
RELAY

09

**K55**  
RELAY

10

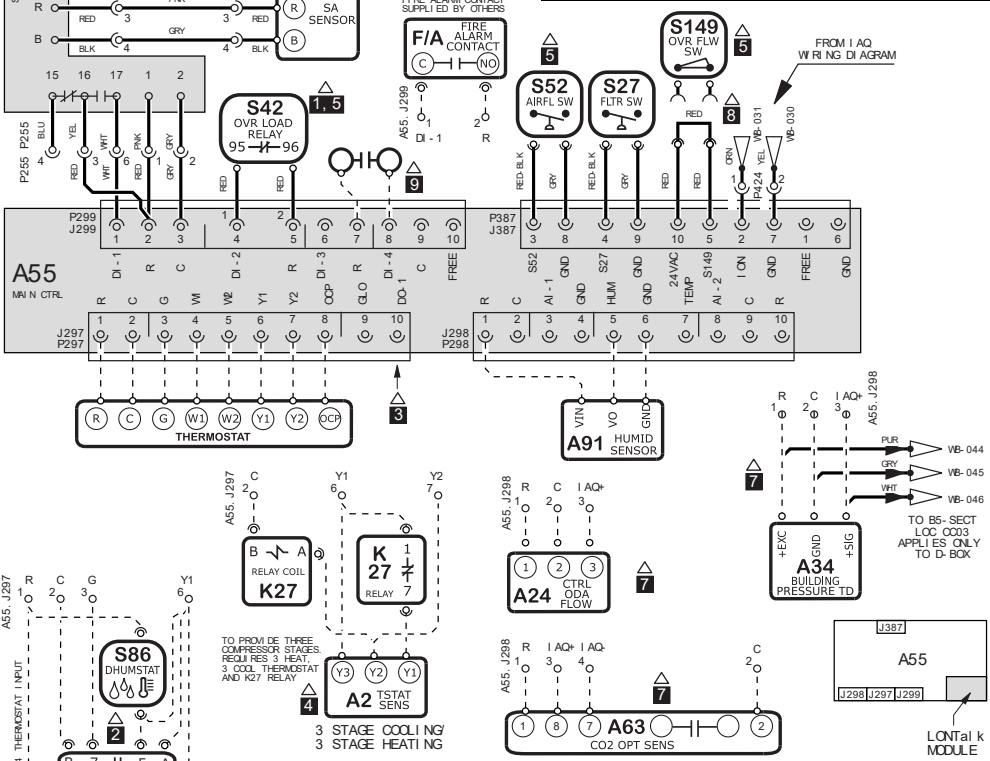
Model: LC, LG, LH, LD Series RTU  
Thermostat  
Voltage: All Voltages  
Supersedes: 538078-01 Form No: 538078-02 Rev: 0

7x10  
CUT  
SIZE

| REV | EC NO.     | DATE       | BY   | APVD | REVISION NOTE                     |
|-----|------------|------------|------|------|-----------------------------------|
| --- | CN-012295C | 04-03-2024 | MXR6 | MXT5 | ORIGINATED AT PD&R CARROLLTON, TX |
|     |            |            |      |      |                                   |
|     |            |            |      |      |                                   |

**KEY LIST**

| LOCATION | COMPONENT DESCRIPTION                       |
|----------|---|
| CC07     | A2 SENSOR, ELECTRONIC THERMOSTAT            |
| DD06     | A24 CONTROL, OUTDOOR AIR FLOW CFM           |
| FF06     | A34 TRANSDUCER, BUILDING PRESSURE           |
| AA05     | A55 CONTROL BOARD, MAIN                     |
| EE07     | A63 SENSOR, CO2 (IAQ) OPTIONAL              |
| DD06     | A91 SENSOR, HUMIDITY                        |
| BB02     | A171 SENSOR ONE, SMOKE DETECTOR, RETURN AIR |
| BB03     | A172 SENSOR TWO, SMOKE DETECTOR, SUPPLY AIR |
| AA01     | A173 CONTROL MODULE, SMOKE DETECTOR         |
| CC03     | F/A FIRE ALARM CONTACT                      |
| CC07     | K27 RELAY, TRANSFORMER                      |
| AA08     | K55 RELAY, BLOWER (SUPERMARKET REHEAT)      |
| DD04     | S27 SWITCH, FILTER                          |
| BB04     | S42 SWITCH, OVERLOAD RELAY BLOWER MOTOR     |
| DD04     | S52 SWITCH, AIRFLOW                         |
| AA07     | S86 SWITCH, DEHUMIDISTAT                    |
| EE03     | S149 SWITCH, OVERFLOW ONE                   |



- NOTES**
- FOR MOTORS WITH S42 EXTERNAL OVERLOAD LESS INVERTER, SEE INVERTER WITH BY PASS FOR S42 HOOK UP
  - USE S86 DEHUMIDISTAT AND K55 FOR OPTIONAL SUPERMARKET REHEAT SCHEME, PRODIGY PARAMETERS NEED TO BE MODIFIED UNDER THE SETTINGS MENU OR VIA UC SOFTWARE FOR SIMULTANEOUS HEATING AND COOLING
  - P297-10 (SR) IS SERVICE RELAY OUTPUT (24VAC) IF USED CONNECT TO AN INDICATOR LIGHT
  - THERMOSTAT HOOKUP FOR PROGRAMMABLE CONFIGURATION OF THE BOARD (A55)
  - CORE CONTROLLER SETTINGS MUST BE MODIFIED WHEN S42, S52, S149 ARE INSTALLED
  - CONNECT P252 OF A172 SENSOR TO J261 ON SUPPLY AIR SMOKE DETECTOR ONLY
  - FROM A63, A34 & A24, ONLY ONE CAN BE USED AT A TIME TO CONNECT TO J298
  - REMOVE JUMPER TO INSTALL S149
  - EXTERNAL HUMIDITROL CONTACTS

|           |           |              |           |           |
|-----------|-----------|--------------|-----------|-----------|
| HEATING   | COOLING   | COOLING      | ACCS      | ACCS      |
| SECTION A | SECTION B | SECTION B3/5 | SECTION C | SECTION D |

**WIRING DIAGRAM FLOW**

**FIGURE 16**

## Mobile Service App

Setup and configure each rooftop unit using the mobile service app (Android or iOS devices supported).

### A-Mobile Device Requirements

- Bluetooth connection.
- Android hardware requires 2GB RAM and a 2Ghz core processor. Tablets are supported.
- The app is available for both iOS 11.0 or higher (App Store) and Android 9.0 or higher (Google Play).

### B-Download the App

Use your mobile device to scan the QR code from the cover page and download the mobile service app to your mobile device.

### C-Pair the App to the Unit Controller

- 1 - Apply power to the unit and wait until the Unit Controller has booted-up (approximately two minutes).
- 2 - Press and hold the pair button for five seconds. See FIGURE 18.
- 3 - The unit (or list of units) will appear; select the appropriate unit. When the app code matches the four-character code on the Unit Controller display, the unit is paired (within 10 seconds). Note the following:
  - The app will list the units by signal strength; the RTU name will be displayed.
  - Once paired, the RTU name, model number, serial number and firmware version will be displayed.

Please refer to the manufacturer's website for additional technical information and self-help support.

## D-App Menus

See FIGURE 17 for the menu overview. Follow the app prompts in the Install, Network Integration, and Test and Balance menus. Verify the app is setup properly for the unit application (including the date and time). Refer to FIGURE 19, FIGURE 20, and FIGURE 21.

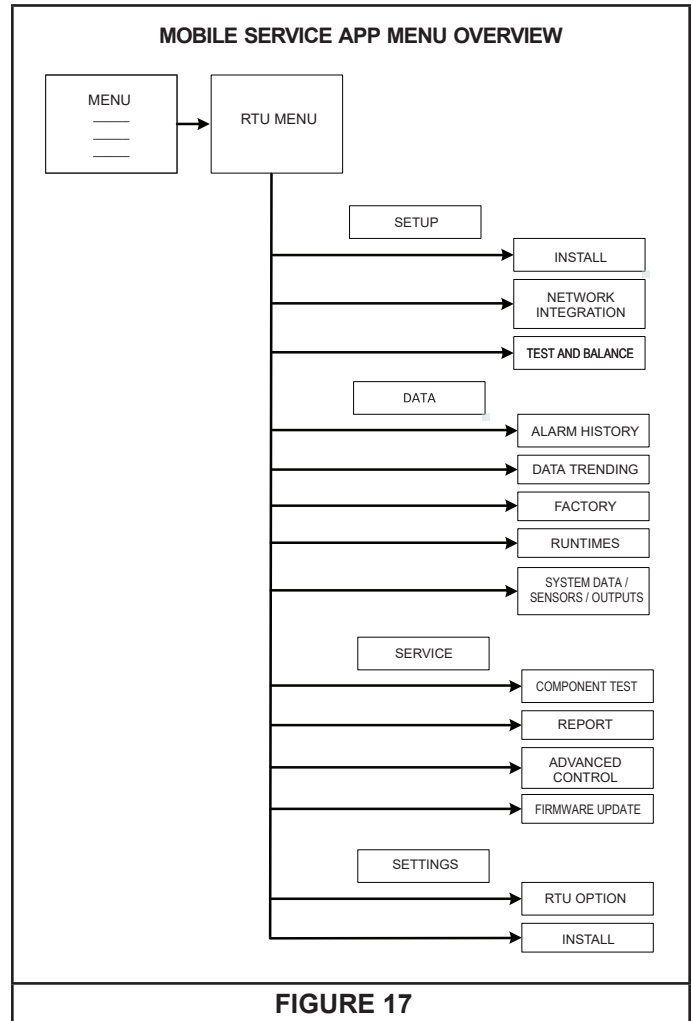


FIGURE 17

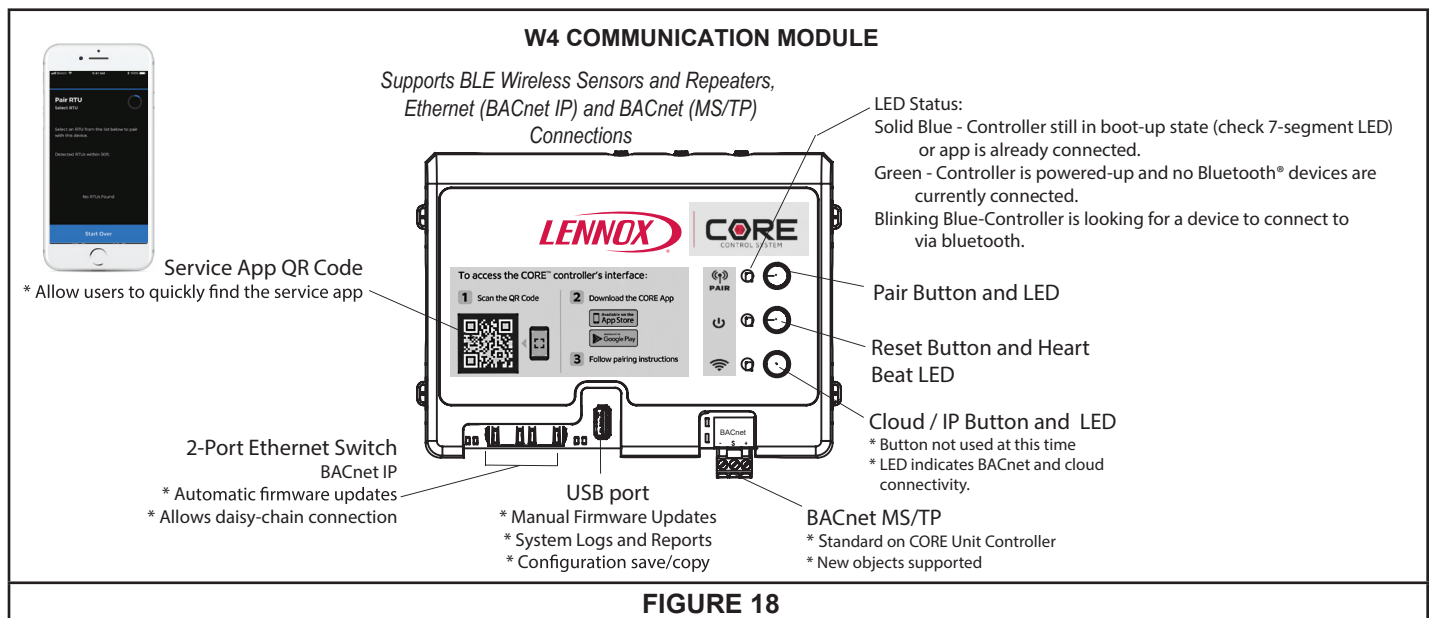
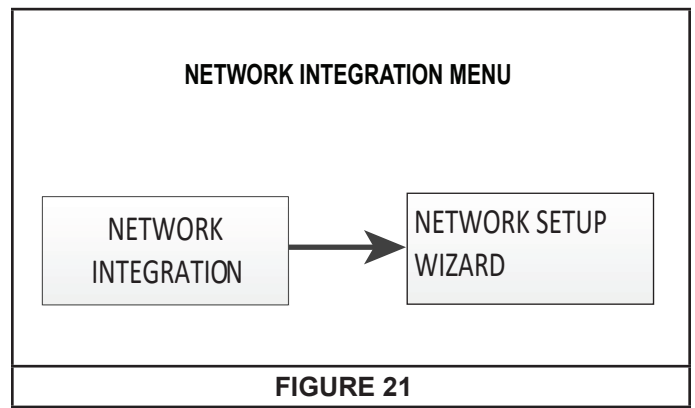
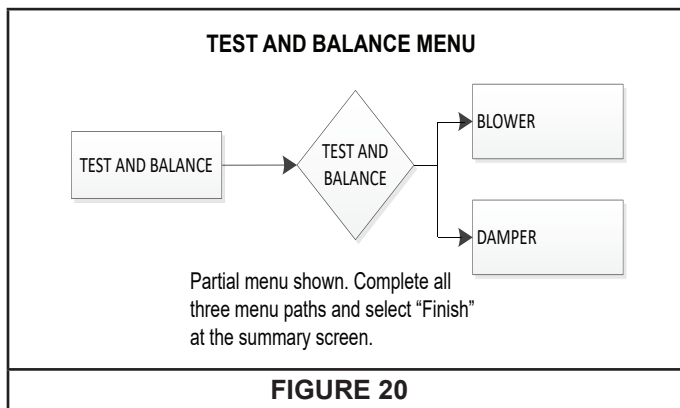
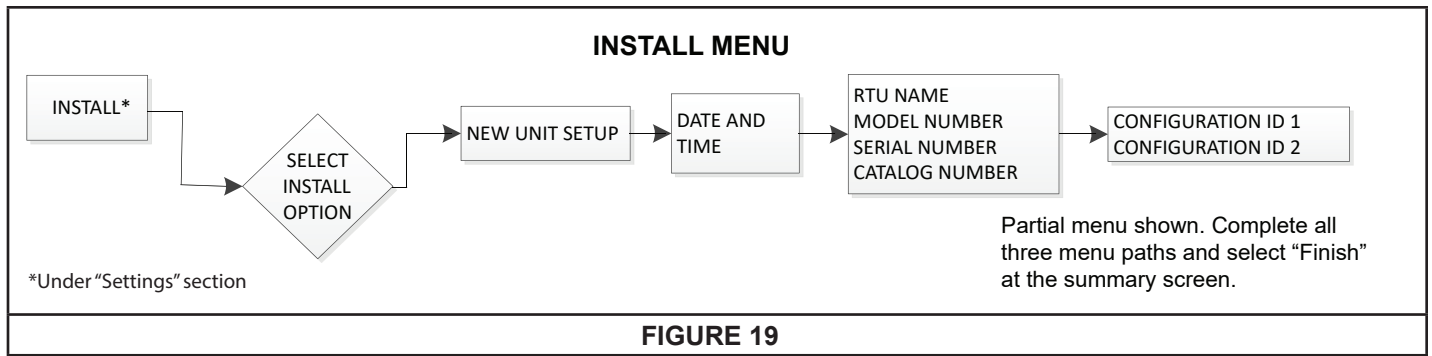
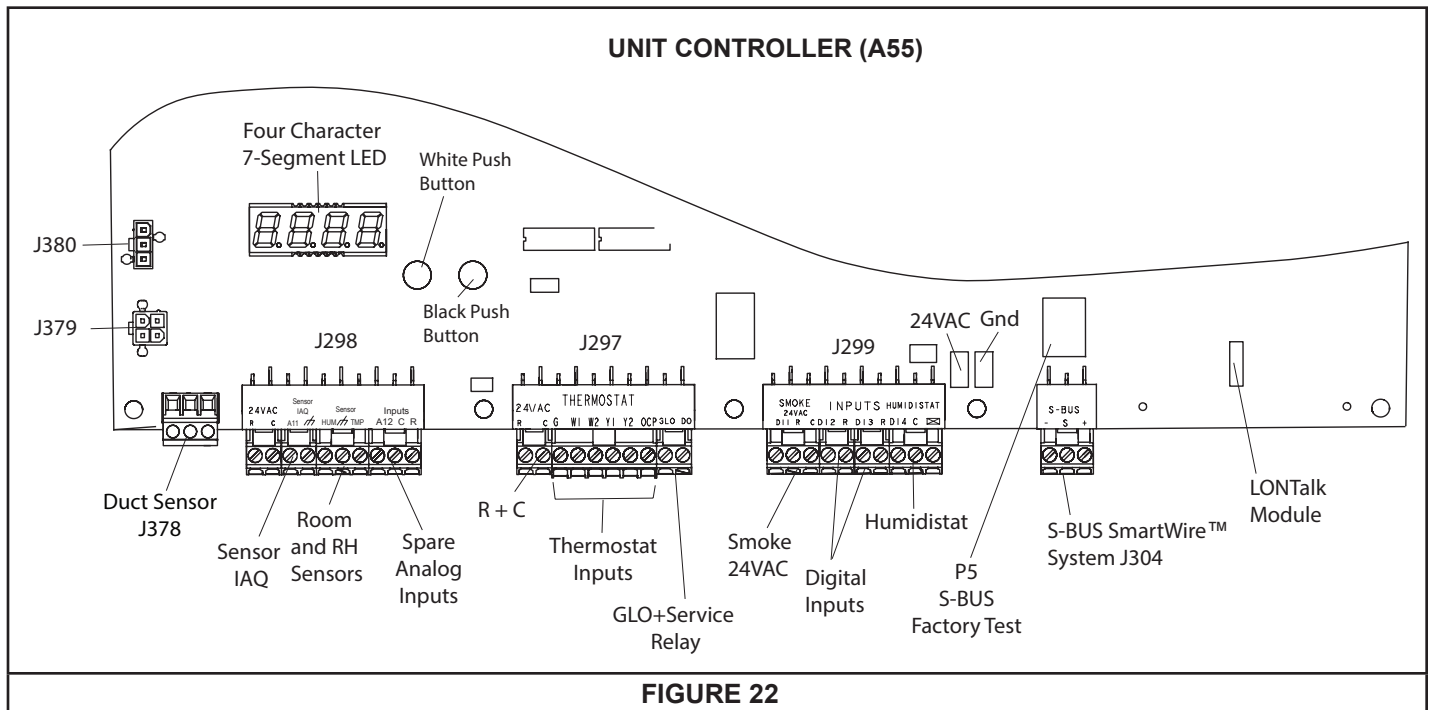


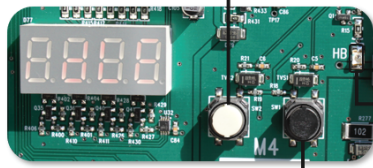
FIGURE 18



## E-Unit Controller Components

See FIGURE 22 for Unit Controller components. See FIGURE 22 and TABLE 2 for pushbutton and LED functions.





**TEST BUTTON**

- \* Short press will put the unit into test mode - tESt
- \* Long press will put the unit into setup mode for two-stage thermostat - StAt

HB LED – blinks while M4 is powered

**RESET BUTTON**

- \* Short press will clear unit delays (lockouts) - CLdL
- \* Long press will reset the M4 Unit Controller - rSt

- \* Short press is about 2 to 5 seconds in duration.
- \* Long press is about 5 to 8 seconds in duration

*\*Short Press (2 – 5 Seconds), Long Press (5 – 10 seconds)*

**FIGURE 23**

**TABLE 2**

**UNIT CONTROLLER PUSHBUTTON CODES**

| Code | Cause   | Action         |
|------|---|----------------|
| CLdL | Black Button: Short Press                           | Clear Delays   |
| rSt  | Black Button: Long Press                            | Reset          |
| tESt | White Button: Short Press                           | TSTAT Test     |
| StAt | White Button: Long Press (In Pre-Install state)     | TSTAT Override |
| tESt | White Button: Long Press (NOT in Pre-Install State) | TSTAT Test     |

Short Press : 2 to 5 seconds.  
 Long Press : 5 to 8 seconds.

## Blower Operation and Adjustments

Units are equipped with variable speed, direct drive blowers. The installer is able to enter the design-specified supply air CFM into the Unit Controller for optimal efficiency. The Unit Controller calibrates the supply air volume which eliminates the need to manually take duct static measurements. Refer to *C-Adjusting Unit CFM - Ultra High Efficiency Direct Drive Blowers*.

### ⚠ IMPORTANT

Three phase scroll compressors must be phased sequentially for correct compressor and blower rotation. Follow "COOLING START-UP" section of installation instructions to ensure proper compressor and blower operation.

#### A-Blower Operation

Refer to the Unit Controller Setup Guide to energize blower. Use the mobile service app menu; see:

#### SERVICE > TEST

### ⚠ WARNING

- 1- Make sure that unit is installed in accordance with the installation instructions and applicable codes.
- 2- Inspect all electrical wiring, both field and factory-installed, for loose connections. Tighten as required.
- 3- Check to ensure that refrigerant lines do not rub against the cabinet or against other refrigerant lines.
- 4- Check voltage at disconnect switch. Voltage must be within range listed on nameplate. If not, consult power company and have voltage condition corrected before starting unit.
- 5- Make sure filters are new and in place before start-up.

**Direct-drive motor may not immediately stop when power is interrupted to the Unit Controller. Disconnect unit power before opening the blower compartment. The Controller's digital inputs must be used to shut down the blower. See Unit Controller manual for operation sequences.**

#### B-Determining Unit CFM

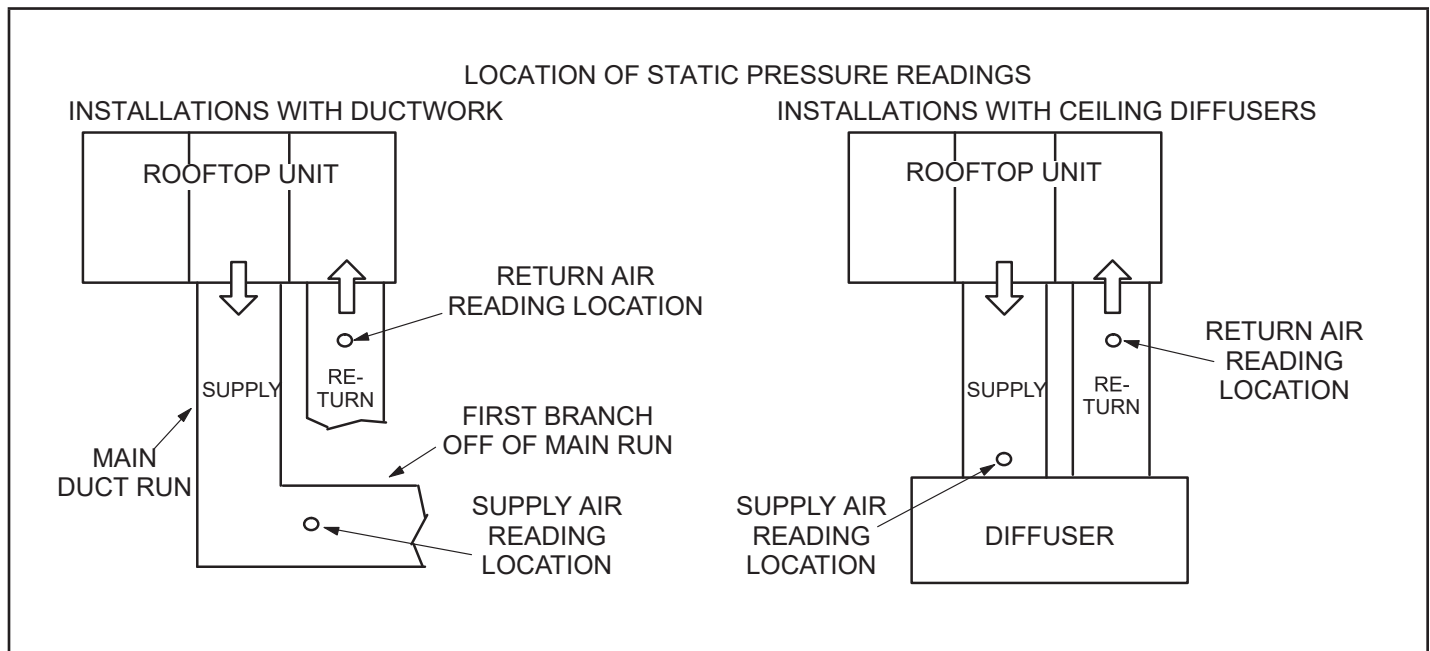
- 1 - The following measurements must be made with air filters in place.
- 2 - With all access panels in place, measure static pressure external to unit (from supply to return). Blower performance data is based on static pressure readings taken in locations shown in FIGURE 24.

**NOTE** - Static pressure readings can vary if not taken where shown.

- 3 - Measure the indoor blower wheel RPM.
- 4 - Referring to the Blower Data tables, use static pressure and RPM readings to determine unit CFM. Use the Accessory Air Resistance tables when installing units with any of the options or accessories listed. Refer to TABLE 3 for minimum airflow when electric heat is installed.

**TABLE 3  
MINIMUM AIRFLOW-LCM UNITS WITH ELECTRIC  
HEAT (DIRECT DRIVE)**

| kW      | CFM                             |
|---------|---------------------------------|
|         | Downflow and Horizontal Airflow |
| LCM036U | 1350                            |
| LCM048U | 1350                            |
| LCM060U | 1800                            |
| LCM074U | 1800                            |



**FIGURE 24**

## C-Adjusting Unit CFM

The supply CFM can be adjusted by changing Unit Controller settings. Refer to TABLE 4 for menu paths and default settings. Record any CFM changes on the parameter settings label located on the inside of the compressor access panel.

### CAUTION

The BLOWER CALIBRATION process starts the in door blower at operational speeds and moves the economizer damper blades. Before starting this process, replace any access panels and close all unit doors except compressor compartment door.

Blower calibration is required only on units that are newly installed or if there is a change in the duct work or air filters after installation. Use the mobile service app to navigate to the **SETUP>TEST & BALANCE>BLOWER** menu.

After the new CFM values are entered, select **START CALIBRATION**. The blower calibration status is displayed as a % complete. Upon successful completion, the mobile service app will display **CALIBRATION SUCCESS** and go back to the blower calibration screen.

*IMPORTANT - The default value for Cooling Low CFM is lower than a traditional single- or two-speed blower. If operating the unit with a 2 or 3-stage controller (2 or 3-stage thermostat, DDC controller, etc.), it is recommended to increase the Cooling Low CFM default value to a suitable level for part load cooling (typically 60% of full load CFM).*

**TABLE 4  
DIRECT DRIVE PARAMETER SETTINGS**

| Parameter  | Factory Setting |          |          |          | Field Setting | Description  |
|--|-----------------|----------|----------|----------|---------------|--|
|  | 036             | 048      | 060      | 074      |               |  |
| <i>NOTE - Any changes to Smoke CFM setting must be adjusted before the other CFM settings. Use SETTINGS &gt; RTU OPTIONS &gt; EDIT PARAMETERS = 12</i> |                 |          |          |          |               |  |
| BLOWER SMOKE CFM   | 1200            | 1600     | 2000     | 2400     | CFM           | Smoke blower speed   |
| <b>SETUP &gt; TEST &amp; BALANCE &gt; BLOWER</b>   |                 |          |          |          |               |  |
| BLOWER HEATING HIGH CFM  | 1350            | 1600     | 2000     | 2000     | CFM           | High heat blower speed   |
| BLOWER HEATING LOW CFM   | 1025            | 1200     | 1500     | 1500     | CFM           | Low heat blower speed<br>Applies to:<br>Units with Heat Code = P, K, R<br>OR<br>P-Volt + Heat Code = B, Q, X |
| BLOWER COOLING HIGH CFM  | 1100            | 1450     | 1825     | 2200     | CFM           | High cooling blower speed  |
| BLOWER COOLING LOW CFM   | 575             | 750      | 950      | 950      | CFM           | Low cooling blower speed   |
| BLOWER VENTILATION CFM   | 575             | 750      | 950      | 1150     | CFM           | Ventilation blower speed   |
| <b>SETUP &gt; TEST &amp; BALANCE &gt; DAMPER</b>   |                 |          |          |          |               |  |
| BLOWER HIGH CFM DAMPER POS %   | 0%              | 0%       | 0%       | 0%       | %             | Minimum damper position for high speed blower operation.   |
| BLOWER LOW CFM DAMPER POS%   | 0%              | 0%       | 0%       | 0%       | %             | Minimum damper position for low speed blower operation.  |
| BLOWER EXHAUST DAMPER POS%   | 50%             | 50%      | 50%      | 50%      | %             | Minimum damper position for power exhaust operation.   |
| <b>SETTINGS &gt; RTU OPTIONS &gt; EDIT PARAMETERS = 216</b>  |                 |          |          |          |               |  |
| POWER EXHAUST DEADBAND %   | 10%             | 10%      | 10%      | 10%      | %             | Deadband % for power exhaust operation.  |
| <b>SETTINGS &gt; RTU OPTIONS &gt; EDIT PARAMETER = 10 (Applies to Thermostat Mode ONLY)</b>  |                 |          |          |          |               |  |
| FREE COOLING STAGE-UP DELAY  | 300 sec.        | 300 sec. | 300 sec. | 300 sec. | sec           | Number of seconds to hold indoor blower at low speed before switching to indoor blower at high speed.        |

*Installer - Circle applicable unit model number and record any parameter changes under "Field Setting" column. Settings need to be recorded by installer for use when Unit Controller is replaced or reprogrammed.*

**BLOWER DATA**

**1.5 HP**

**BLOWER TABLE INCLUDES RESISTANCE FOR BASE UNIT ONLY WITH DRY INDOOR COIL AND AIR FILTERS IN PLACE.**

FOR ALL UNITS ADD:

- 1- Any factory installed options air resistance (heat section, economizer, etc).
- 2- Any field installed accessories air resistance (duct resistance, diffuser, etc).

**Minimum Air Volume Required for Different Gas Heat Sizes:**

Standard Heat - 1075 cfm; Medium Heat - 1150 cfm; High Heat - 15w00 cfm

**DOWNFLOW**

| Total Air<br>cfm | Total Static Pressure - in. w.c. |       |      |       |      |       |      |       |      |       |      |       |      |       |      |       |      |       |      |       |      |       |      |       |      |       |
|------------------|----------------------------------|-------|------|-------|------|-------|------|-------|------|-------|------|-------|------|-------|------|-------|------|-------|------|-------|------|-------|------|-------|------|-------|
|                  | 0.1                              |       | 0.2  |       | 0.3  |       | 0.4  |       | 0.5  |       | 0.6  |       | 0.7  |       | 0.8  |       | 0.9  |       | 1.0  |       | 1.1  |       | 1.2  |       | 1.3  |       |
|                  | RPM                              | Watts | RPM  | Watts | RPM  | Watts | RPM  | Watts | RPM  | Watts | RPM  | Watts | RPM  | Watts | RPM  | Watts | RPM  | Watts | RPM  | Watts | RPM  | Watts | RPM  | Watts | RPM  | Watts |
| 400              | ---                              | ---   | 734  | 19    | 823  | 40    | 910  | 60    | 985  | 78    | ---  | ---   | ---  | ---   | ---  | ---   | ---  | ---   | ---  | ---   | ---  | ---   | ---  | ---   | ---  | ---   |
| 600              | 766                              | 28    | 856  | 51    | 944  | 73    | 1029 | 93    | 1108 | 111   | 1180 | 127   | 1248 | 139   | 1315 | 149   | 1383 | 158   | 1451 | 169   | ---  | ---   | ---  | ---   | ---  | ---   |
| 800              | 899                              | 57    | 989  | 81    | 1079 | 104   | 1163 | 125   | 1242 | 145   | 1317 | 161   | 1386 | 174   | 1454 | 185   | 1519 | 198   | 1582 | 214   | 1643 | 234   | 1701 | 255   | 1755 | 281   |
| 1000             | 1084                             | 95    | 1163 | 117   | 1244 | 139   | 1323 | 160   | 1398 | 180   | 1470 | 196   | 1538 | 211   | 1603 | 227   | 1663 | 245   | 1721 | 267   | 1776 | 292   | 1828 | 320   | 1876 | 350   |
| 1200             | 1319                             | 113   | 1385 | 138   | 1451 | 162   | 1517 | 186   | 1581 | 209   | 1644 | 231   | 1703 | 254   | 1759 | 278   | 1812 | 306   | 1863 | 337   | 1912 | 367   | 1960 | 397   | 2003 | 427   |
| 1400             | 1542                             | 146   | 1596 | 177   | 1649 | 208   | 1703 | 239   | 1757 | 269   | 1809 | 300   | 1860 | 331   | 1909 | 362   | 1956 | 393   | 2003 | 425   | 2050 | 456   | 2095 | 483   | 2139 | 508   |
| 1600             | 1721                             | 225   | 1772 | 258   | 1823 | 291   | 1873 | 324   | 1923 | 356   | 1972 | 388   | 2019 | 419   | 2065 | 450   | 2110 | 480   | 2156 | 510   | 2200 | 539   | 2244 | 565   | 2287 | 590   |
| 1800             | 1909                             | 309   | 1957 | 341   | 2006 | 373   | 2054 | 404   | 2101 | 435   | 2146 | 465   | 2190 | 495   | 2234 | 526   | 2277 | 557   | 2320 | 588   | 2362 | 620   | 2404 | 651   | 2444 | 685   |
| 2000             | 2103                             | 385   | 2148 | 417   | 2193 | 450   | 2239 | 483   | 2283 | 516   | 2325 | 550   | 2367 | 584   | 2408 | 620   | 2449 | 658   | 2490 | 696   | 2529 | 735   | 2568 | 777   | 2605 | 822   |
| 2200             | 2299                             | 478   | 2342 | 514   | 2384 | 552   | 2426 | 590   | 2467 | 630   | 2507 | 671   | 2547 | 714   | 2586 | 757   | 2625 | 800   | 2663 | 844   | 2700 | 889   | 2735 | 935   | 2770 | 982   |
| 2400             | 2500                             | 606   | 2540 | 647   | 2580 | 690   | 2618 | 734   | 2656 | 779   | 2694 | 824   | 2731 | 870   | 2768 | 915   | 2804 | 961   | 2839 | 1006  | 2874 | 1051  | 2907 | 1096  | 2941 | 1141  |
| 2600             | 2704                             | 768   | 2741 | 810   | 2778 | 855   | 2813 | 901   | 2849 | 947   | 2884 | 993   | 2918 | 1039  | 2952 | 1085  | 2986 | 1129  | 3019 | 1173  | 3051 | 1217  | 3083 | 1259  | 3115 | 1300  |
| 2800             | 2908                             | 941   | 2943 | 985   | 2976 | 1030  | 3010 | 1076  | 3042 | 1121  | 3075 | 1166  | 3107 | 1210  | 3139 | 1253  | 3170 | 1296  | 3200 | 1338  | 3231 | 1379  | 3261 | 1419  | 3290 | 1456  |
| 3000             | 3110                             | 1111  | 3142 | 1156  | 3173 | 1201  | 3205 | 1245  | 3236 | 1289  | 3267 | 1332  | 3296 | 1373  | 3325 | 1414  | 3354 | 1455  | 3382 | 1496  | 3412 | 1536  | 3439 | 1573  | 3465 | 1609  |

| Total Air<br>cfm | Total Static Pressure - in. w.g. |       |      |       |      |       |      |       |      |       |      |       |      |       |  |  |  |  |
|------------------|----------------------------------|-------|------|-------|------|-------|------|-------|------|-------|------|-------|------|-------|--|--|--|--|
|                  | 1.4                              |       | 1.5  |       | 1.6  |       | 1.7  |       | 1.8  |       | 1.9  |       | 2.0  |       |  |  |  |  |
|                  | RPM                              | Watts | RPM  | Watts | RPM  | Watts | RPM  | Watts | RPM  | Watts | RPM  | Watts | RPM  | Watts |  |  |  |  |
| 800              | 1805                             | 309   | 1850 | 337   | 1895 | 366   | 1940 | 392   | ---  | ---   | ---  | ---   | ---  |       |  |  |  |  |
| 1000             | 1920                             | 380   | 1962 | 410   | 2005 | 439   | 2050 | 466   | 2094 | 492   | 2138 | 517   | 2181 | 541   |  |  |  |  |
| 1200             | 2045                             | 456   | 2087 | 484   | 2130 | 510   | 2174 | 537   | 2217 | 563   | 2260 | 589   | 2302 | 615   |  |  |  |  |
| 1400             | 2182                             | 531   | 2225 | 555   | 2268 | 581   | 2310 | 610   | 2352 | 640   | 2393 | 671   | 2433 | 703   |  |  |  |  |
| 1600             | 2330                             | 616   | 2371 | 645   | 2412 | 678   | 2452 | 713   | 2491 | 750   | 2530 | 787   | 2568 | 824   |  |  |  |  |
| 1800             | 2484                             | 723   | 2523 | 765   | 2561 | 808   | 2598 | 849   | 2636 | 890   | 2672 | 931   | 2708 | 971   |  |  |  |  |
| 2000             | 2641                             | 868   | 2677 | 915   | 2713 | 961   | 2749 | 1003  | 2784 | 1044  | 2819 | 1084  | 2853 | 1124  |  |  |  |  |
| 2200             | 2804                             | 1028  | 2839 | 1072  | 2873 | 1114  | 2907 | 1155  | 2940 | 1194  | 2973 | 1234  | 3006 | 1272  |  |  |  |  |
| 2400             | 2974                             | 1184  | 3006 | 1225  | 3039 | 1266  | 3071 | 1305  | 3103 | 1344  | 3134 | 1382  | 3166 | 1420  |  |  |  |  |
| 2600             | 3146                             | 1340  | 3177 | 1379  | 3207 | 1417  | 3238 | 1456  | 3269 | 1494  | 3299 | 1532  | 3329 | 1569  |  |  |  |  |
| 2800             | 3319                             | 1493  | 3347 | 1530  | 3376 | 1567  | 3406 | 1605  | 3435 | 1643  | 3465 | 1681  | 3495 | 1718  |  |  |  |  |
| 3000             | 3491                             | 1644  | 3517 | 1680  | 3543 | 1716  | 3572 | 1754  | 3602 | 1792  | 3631 | 1830  | 3661 | 1867  |  |  |  |  |

## BLOWER DATA

### FACTORY INSTALLED OPTIONS/FIELD INSTALLED ACCESSORY AIR RESISTANCE - in. w.g.

| Air Volume<br>cfm | Wet Indoor<br>Coil |             | Condenser<br>Reheat<br>Coil | Gas Heating      |                |           | Electric<br>Heat | Econo-<br>mizer | Filters |         |         |
|-------------------|--------------------|-------------|-----------------------------|------------------|----------------|-----------|------------------|-----------------|---------|---------|---------|
|                   | 036,<br>048        | 060,<br>074 |                             | Standard<br>Heat | Medium<br>Heat | High Heat |                  |                 | MERV 8  | MERV 13 | MERV 16 |
| 800               | 0.01               | ---         | ---                         | 0.02             | 0.02           | 0.02      | 0.04             | 0.01            | 0.04    | 0.05    | 0.04    |
| 1000              | 0.02               | 0.02        | 0.00                        | 0.02             | 0.02           | 0.02      | 0.04             | 0.03            | 0.04    | 0.07    | 0.05    |
| 1200              | 0.03               | 0.04        | 0.00                        | 0.02             | 0.02           | 0.02      | 0.04             | 0.06            | 0.04    | 0.07    | 0.05    |
| 1400              | 0.04               | 0.05        | 0.01                        | 0.02             | 0.02           | 0.03      | 0.04             | 0.09            | 0.04    | 0.07    | 0.06    |
| 1600              | 0.05               | 0.07        | 0.02                        | 0.02             | 0.03           | 0.04      | 0.04             | 0.12            | 0.04    | 0.07    | 0.08    |
| 1800              | 0.06               | 0.08        | 0.02                        | 0.03             | 0.04           | 0.05      | 0.05             | 0.15            | 0.04    | 0.07    | 0.09    |
| 2000              | 0.08               | 0.10        | 0.02                        | 0.03             | 0.04           | 0.06      | 0.05             | 0.18            | 0.05    | 0.08    | 0.10    |
| 2200              | ---                | 0.11        | 0.04                        | 0.04             | 0.04           | 0.07      | 0.05             | 0.18            | 0.05    | 0.08    | 0.11    |
| 2400              | ---                | 0.13        | 0.04                        | 0.04             | 0.05           | 0.08      | 0.05             | 0.20            | 0.05    | 0.08    | 0.12    |

### POWER EXHAUST FAN PERFORMANCE

| Return Air System Static Pressure - in. w.g. | Air Volume Exhausted cfm |
|--|--------------------------|
| 0.00   | 2000                     |
| 0.05   | 1990                     |
| 0.10   | 1924                     |
| 0.15   | 1810                     |
| 0.20   | 1664                     |
| 0.25   | 1507                     |
| 0.30   | 1350                     |
| 0.35   | 1210                     |

### CEILING DIFFUSER AIR THROW DATA

| Air Volume<br>cfm | 'Effective Throw - ft. |          |
|-------------------|------------------------|----------|
|                   | RTD11-95S              | FD11-95S |
| 2600              | 24 - 29                | 19 - 24  |
| 2800              | 25 - 30                | 20 - 28  |
| 3000              | 27 - 33                | 21 - 29  |

<sup>1</sup>Effective throw based on terminal velocities of 75 ft. per minute.

### CEILING DIFFUSERS AIR RESISTANCE - in. w.g.

| Air Volume<br>cfm | RTD11-95S Step-Down Diffuser |                     |                       | FC11-95S Flush Diffuser |
|-------------------|------------------------------|---------------------|-----------------------|-------------------------|
|                   | 2 Ends Open                  | 1 Side & 1 End Open | All Sides & Ends Open |                         |
| 1800              | 0.13                         | 0.11                | 0.09                  | 0.09                    |
| 2000              | 0.15                         | 0.13                | 0.11                  | 0.10                    |
| 2200              | 0.18                         | 0.15                | 0.12                  | 0.12                    |
| 2400              | 0.21                         | 0.18                | 0.15                  | 0.14                    |
| 2600              | 0.24                         | 0.21                | 0.18                  | 0.17                    |
| 2800              | 0.27                         | 0.24                | 0.21                  | 0.20                    |
| 3000              | 0.32                         | 0.29                | 0.25                  | 0.25                    |

## Refrigerant Leak Detection System

### A-System Test

- 1 - Initiate Refrigerant Leak Detection System Test by using the following mobile service app menu path:  
**RTU MENU > COMPONENT TEST > LEAK DETECTION > START TEST**
- 2 - Ensure that indoor blower, outdoor fan, and combustion air blower (LGM only) are energized.

## Cooling Start-Up

### B-Operation

- 1 - Initiate full load cooling operation using the following mobile service app menu path:

**SERVICE > TEST > COOL > COOL 3**

(COOL 4 on 074U units)

**NOTE** - Refer to Cooling Operation section for ultra high efficiency unit operation in zone sensor mode.

- 2 - Units contain one refrigerant circuit or stage.
- 3 - Unit is charged with R-454B refrigerant. See unit rating plate for correct amount of charge.
- 4 - Refer to Cooling Operation and Adjustment section for proper method to check refrigerant charge.

### C-Compressor Controls

See unit wiring diagram to determine which controls are used on each unit. Optional controls are identified on wiring diagrams by arrows at junction points.

- 1 - High Pressure Switch (S4)

The compressor circuit is protected by a high pressure switch which opens at 640 psig  $\pm$  10 psig (4413 kPa  $\pm$  70 kPa) and automatically resets at 475 psig  $\pm$  20 psig (3275kPa  $\pm$  138 kPa).

- 2 - Low Pressure Switch (S87)

The compressor circuit is protected by a loss of charge switch. Switch opens at 40 psig  $\pm$  5 psig (276  $\pm$  34 kPa) and automatically resets at 90 psig  $\pm$  5 psig (621 kPa  $\pm$  34 kPa).

- 3 - Prognostics and Diagnostics Sensors (RT42, RT44, RT46, RT48)

Four thermistors are located on specific points in the refrigeration circuit. The thermistors provide constant temperature feedback to the Unit Controller to protect the compressor. Thermistors take the place of the freezestat and low ambient pressure switch.

- 4 - Compressor Crankcase Heater (HR1)

Crankcase heater must be energized at all times to prevent compressor damage due to refrigerant migration. Energize crankcase heater 24 hours before unit start-up by setting thermostat so that there is no cooling demand (to prevent compressor from cycling) and apply power to unit.

### D-Refrigerant Charge and Check - All-Aluminum Coil

**WARNING** - Do not exceed nameplate charge under any condition.

This unit is factory charged and should require no further adjustment. If the system requires additional refrigerant, reclaim the charge, evacuate the system, and add required nameplate charge.

| Refrigerant Charge R-454B |                      |                     |
|---------------------------|----------------------|---------------------|
| Unit                      | M <sub>e</sub> (lbs) | M <sub>e</sub> (kg) |
| LCM/LGM036                | 4.50                 | 2.0412              |
| LCM/LGM048                | 5.0625               | 2.2963              |
| LCM/LGM060                | 5.0625               | 2.2963              |
| LCM/LGM074                | 5.0625               | 2.2963              |
| LCM/LGM036 W/ Humidrol    | 5.6875               | 2.5798              |
| LCM/LGM048 W/ Humidrol    | 5.5625               | 2.5231              |
| LCM/LGM060 W/ Humidrol    | 5.5625               | 2.5231              |
| LCM/LGM074 W/ Humidrol    | 5.5625               | 2.5231              |

In addition to conventional charging procedures, the following requirements shall be followed.

- Ensure that contamination of different refrigerants does not occur when using charging equipment. Hoses or lines shall be as short as possible to minimize the amount of refrigerant contained in them.
- Cylinders shall be kept in an appropriate position according to the instructions.
- Ensure that the unit is earth grounded prior to charging the system with refrigerant.
- Label the system when charging is complete (if not already).
- Extreme care shall be taken not to overfill the unit.

Prior to recharging the system, it shall be pressure-tested with the appropriate purging gas. The system shall be leak-tested on completion of charging but prior to commissioning. A follow up leak test shall be carried out prior to leaving the site.

- When removing refrigerant from a system, either for servicing or decommissioning, it is recommended good practice that all refrigerants are removed safely.
- When transferring refrigerant into cylinders, ensure that only appropriate refrigerant recovery cylinders are employed. Ensure that the correct number of cylinders for holding the total system charge is available. All cylinders to be used are designated for the recovered refrigerant and labelled for that refrigerant (i. e. special cylinders for the recovery of refrigerant). Cylinders shall be complete with pressure-relief valve and associated shut-off valves in good working order. Empty recovery cylinders are evacuated and, if possible, cooled before recovery.
- The recovery equipment shall be in good working order with a set of instructions concerning the equipment that is at hand and shall be suitable for the recovery of all appropriate refrigerants includ-

- dition, a set of calibrated weighing scales shall be available and in good working order. Hoses shall be complete with leak-free disconnect couplings and in good condition. Before using the recovery machine, check that it is in satisfactory working order, has been properly maintained and that any associated electrical components are sealed to prevent ignition in the event of a refrigerant release. Consult manufacturer if in doubt.
- The recovered refrigerant shall be returned to the refrigerant supplier in the correct recovery cylinder, and the relevant waste transfer note arranged. Do not mix refrigerants in recovery units and especially
- If compressors or compressor oils are to be removed, ensure that they have been evacuated to an acceptable level to make certain that flammable refrigerant does not remain within the lubricant. The evacuation process shall be carried out prior to returning the compressor to the suppliers. Only electric heating to the compressor body shall be employed to accelerate this process. When oil is drained from a system, it shall be carried out safely.

**NOTE** - System charging is not recommended below 60°F (15°C). In temperatures below 60°F (15°C), the charge must be weighed into the system.

If weighing facilities are not available, or to check the charge, use the following procedure:

- 1 - Make sure outdoor coil is clean. Attach gauge manifolds and operate unit at full CFM in cooling mode with economizer disabled until system stabilizes (approximately five minutes). Make sure all outdoor air dampers are closed.

- 2 - Compare the normal operating pressures to the pressures obtained from the gauges. Check unit components if there are significant differences.
- 3 - Measure the outdoor ambient temperature and the suction pressure. Refer to the charging curve to determine a target liquid temperature.

**NOTE** - Pressures are listed for sea level applications.

- 4 - Use the same thermometer to accurately measure the liquid temperature (in the outdoor section).
  - If measured liquid temperature is higher than the target liquid temperature, add refrigerant to the system.
  - If measured liquid temperature is lower than the target liquid temperature, recover some refrigerant from the system..
- 5 - Add or remove charge in increments. Allow the system to stabilize each time refrigerant is added or removed.
- 6 - Continue the process until measured liquid temperature agrees with the target liquid temperature. Do not go below the target liquid temperature when adjusting charge. Note that suction pressure can change as charge is adjusted.
- 7 - Example: At 95°F outdoor ambient and a measured suction pressure of 130psig, the target liquid temperature is 97°F. For a measured liquid temperature of 106°F, add charge in increments until measured liquid temperature agrees with the target liquid temperature.

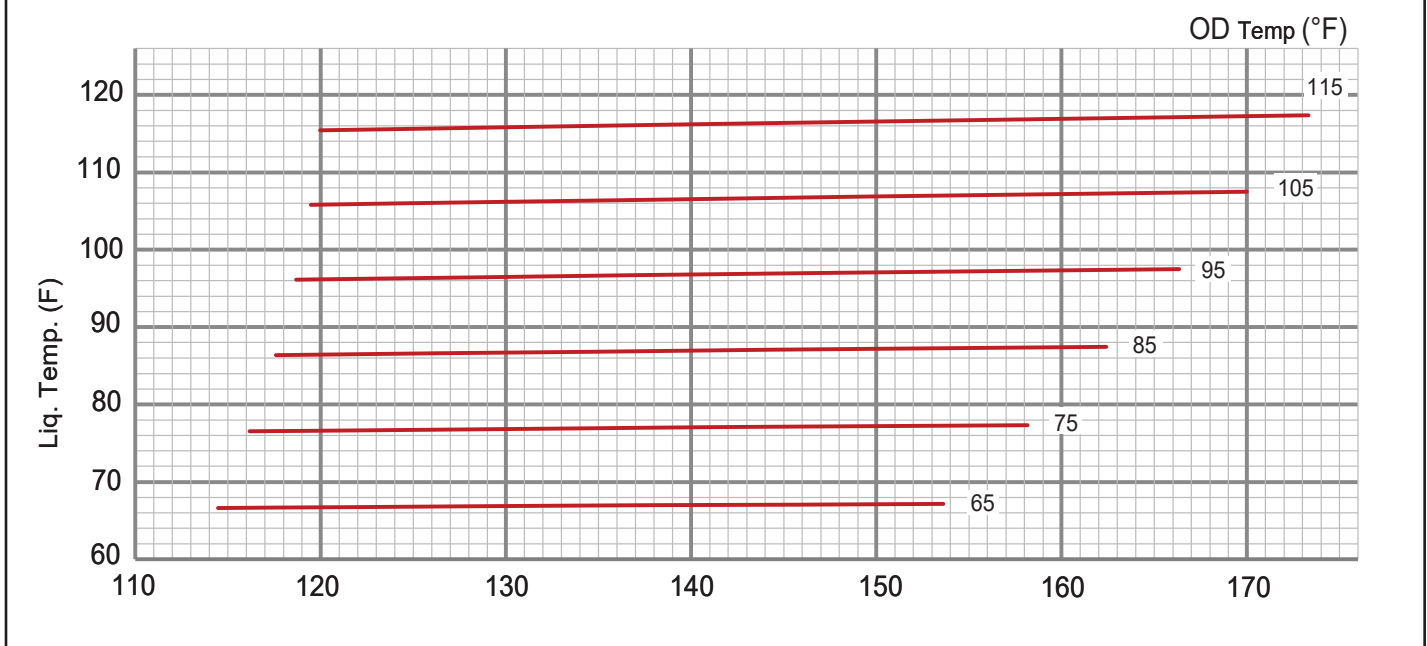
**TABLE 5**

**036 Normal Operating Pressures - No Reheat - All-Aluminum Coil - 581223-01**

**Outdoor Coil Entering Air Temperature**

| 65°F        |             | 75°F        |             | 85°F        |             | 95°F        |             | 105°F       |             | 115°F       |             |
|-------------|-------------|-------------|-------------|-------------|-------------|-------------|-------------|-------------|-------------|-------------|-------------|
| Suct (psig) | Disc (psig) | Suct (psig) | Disc (psig) | Suct (psig) | Disc (psig) | Suct (psig) | Disc (psig) | Suct (psig) | Disc (psig) | Suct (psig) | Disc (psig) |
| 114         | 214         | 116         | 251         | 118         | 292         | 119         | 340         | 119         | 392         | 120         | 449         |
| 122         | 216         | 124         | 253         | 126         | 294         | 128         | 341         | 129         | 393         | 131         | 450         |
| 138         | 222         | 141         | 257         | 144         | 298         | 147         | 344         | 150         | 395         | 152         | 452         |
| 154         | 228         | 158         | 263         | 162         | 303         | 166         | 348         | 170         | 399         | 173         | 454         |

**036 Charging Curve - No Reheat - All-Aluminum Coil - 581223-01**



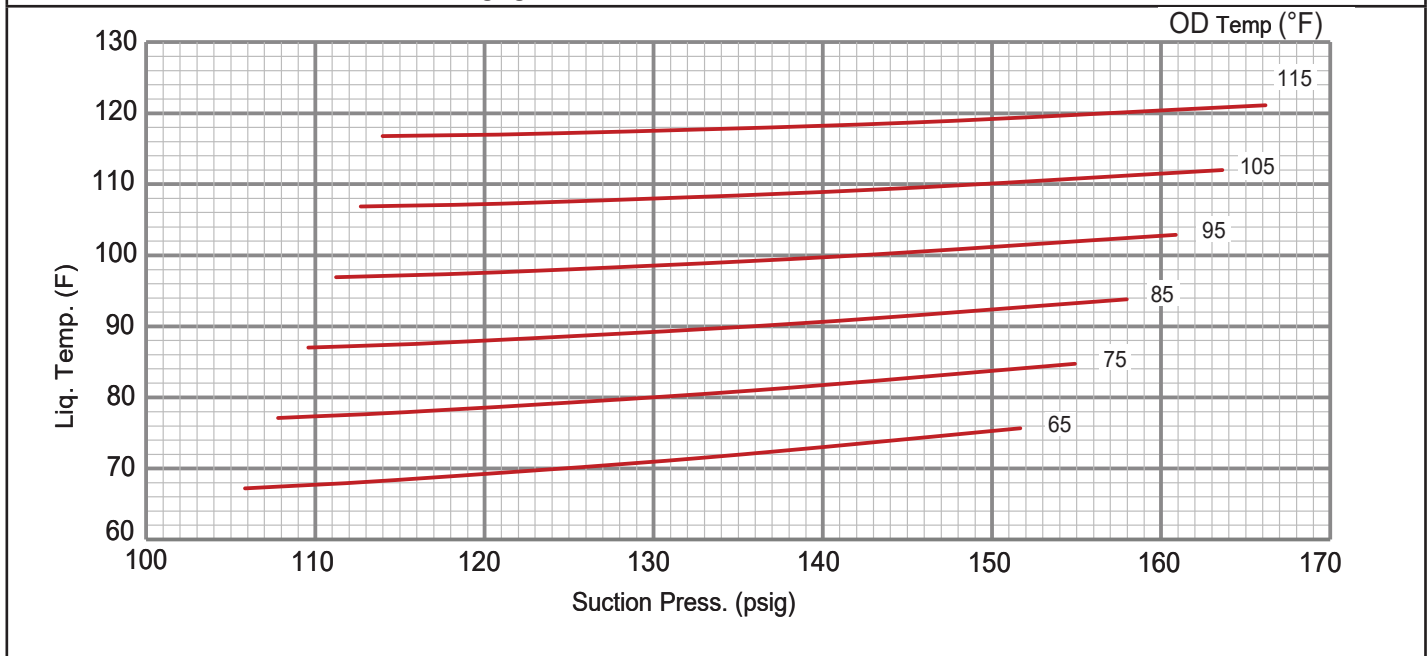
**TABLE 6**

**048 Normal Operating Pressures - No Reheat - All-Aluminum Coil - 581224-01**

**Outdoor Coil Entering Air Temperature**

| 65°F        |             | 75°F        |             | 85°F        |             | 95°F        |             | 105°F       |             | 115°F       |             |
|-------------|-------------|-------------|-------------|-------------|-------------|-------------|-------------|-------------|-------------|-------------|-------------|
| Suct (psig) | Disc (psig) | Suct (psig) | Disc (psig) | Suct (psig) | Disc (psig) | Suct (psig) | Disc (psig) | Suct (psig) | Disc (psig) | Suct (psig) | Disc (psig) |
| 106         | 224         | 108         | 259         | 110         | 300         | 111         | 347         | 113         | 400         | 114         | 459         |
| 115         | 227         | 117         | 261         | 119         | 302         | 121         | 349         | 123         | 401         | 124         | 460         |
| 133         | 235         | 136         | 269         | 138         | 309         | 141         | 354         | 143         | 406         | 145         | 463         |
| 152         | 247         | 155         | 280         | 158         | 318         | 161         | 363         | 164         | 413         | 166         | 470         |

**048 Charging Curve - No Reheat - All-Aluminum Coil - 581224-01**



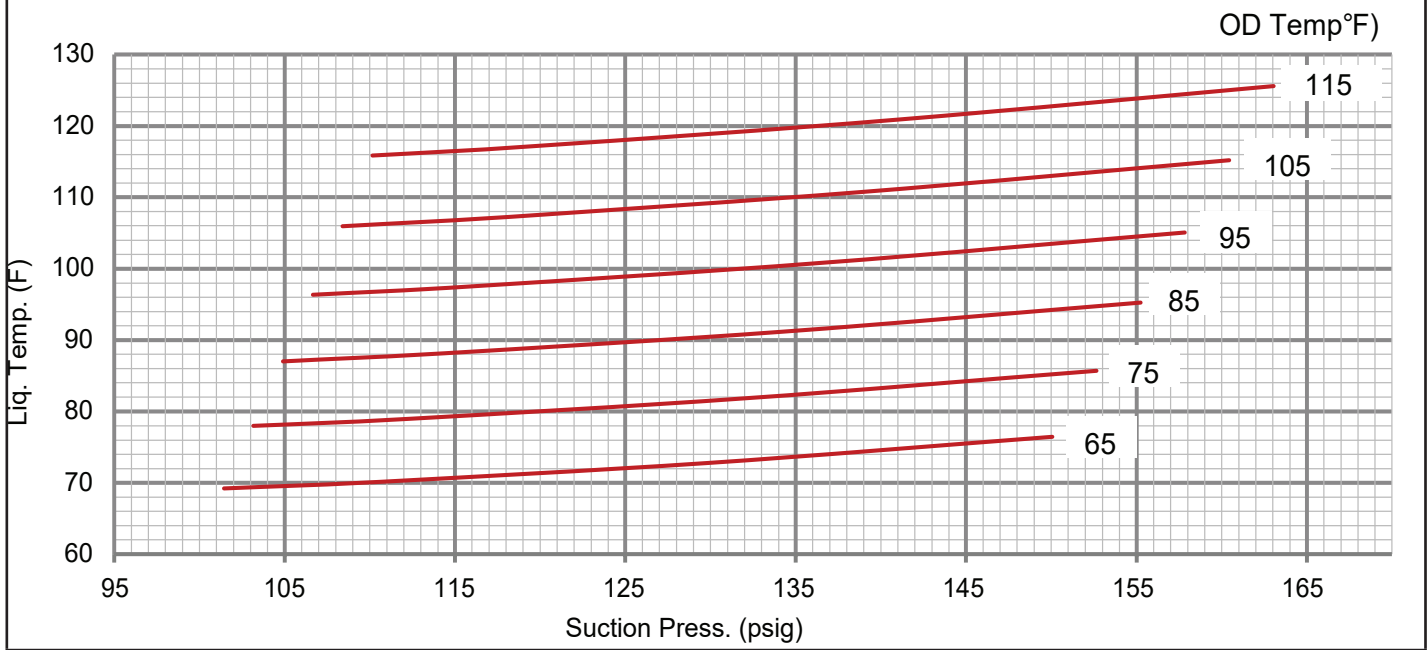
**TABLE 7**

**060 Normal Operating Pressures - No Reheat - All-Aluminum Coil - 581225-01**

**Outdoor Coil Entering Air Temperature**

| 65°F        |             | 75°F        |             | 85°F        |             | 95°F        |             | 105°F       |             | 115°F       |             |
|-------------|-------------|-------------|-------------|-------------|-------------|-------------|-------------|-------------|-------------|-------------|-------------|
| Suct (psig) | Disc (psig) | Suct (psig) | Disc (psig) | Suct (psig) | Disc (psig) | Suct (psig) | Disc (psig) | Suct (psig) | Disc (psig) | Suct (psig) | Disc (psig) |
| 101         | 231         | 103         | 269         | 105         | 313         | 107         | 360         | 108         | 413         | 110         | 471         |
| 111         | 236         | 112         | 274         | 114         | 317         | 116         | 364         | 118         | 417         | 120         | 475         |
| 130         | 243         | 132         | 281         | 134         | 324         | 137         | 372         | 139         | 424         | 141         | 482         |
| 150         | 250         | 153         | 288         | 155         | 331         | 158         | 378         | 160         | 431         | 163         | 488         |

**060 Charging Curve - No Reheat - All-Aluminum Coil - 581225-01**



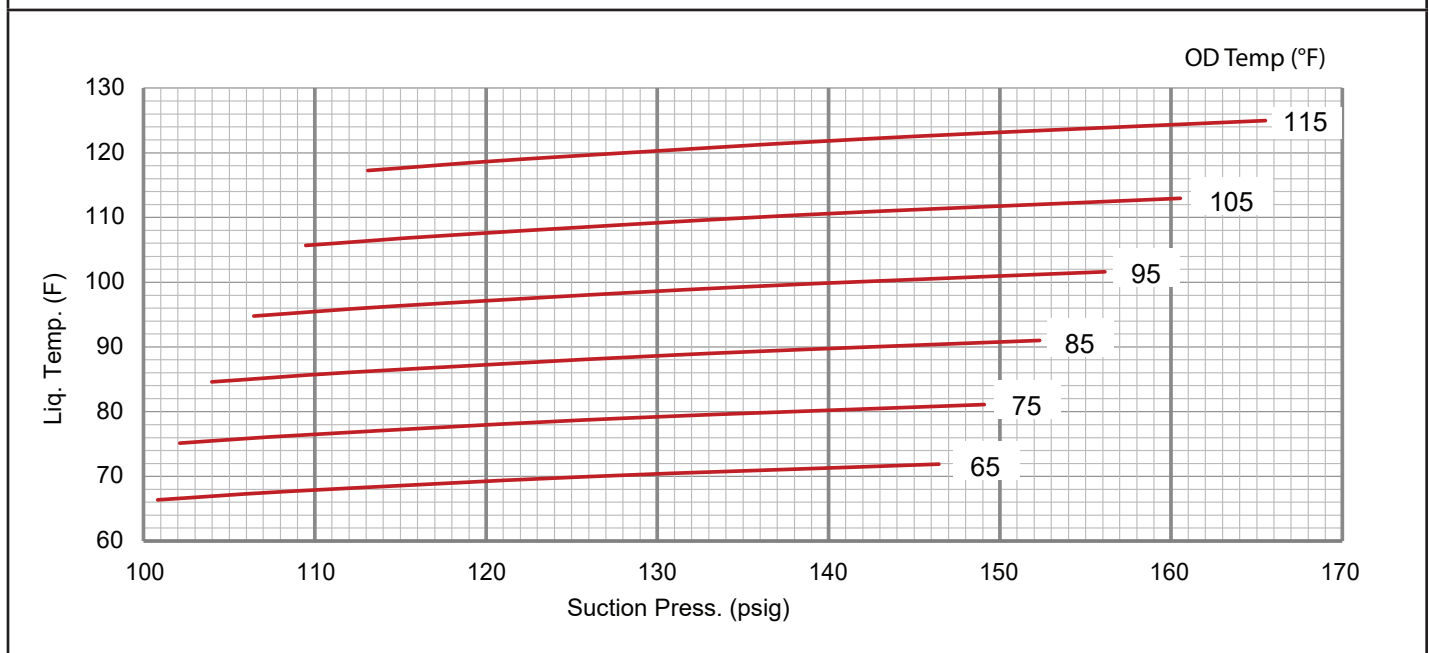
**TABLE 8**

**074 Normal Operating Pressures - No Reheat - All-Aluminum Coil - 581226-01**

**Outdoor Coil Entering Air Temperature**

| 65°F        |             | 75°F        |             | 85°F        |             | 95°F        |             | 105°F       |             | 115°F       |             |
|-------------|-------------|-------------|-------------|-------------|-------------|-------------|-------------|-------------|-------------|-------------|-------------|
| Suct (psig) | Disc (psig) | Suct (psig) | Disc (psig) | Suct (psig) | Disc (psig) | Suct (psig) | Disc (psig) | Suct (psig) | Disc (psig) | Suct (psig) | Disc (psig) |
| 101         | 237         | 102         | 279         | 104         | 324         | 106         | 370         | 109         | 419         | 113         | 470         |
| 108         | 242         | 110         | 284         | 112         | 329         | 115         | 375         | 118         | 424         | 122         | 475         |
| 126         | 252         | 128         | 294         | 131         | 338         | 134         | 384         | 138         | 433         | 142         | 484         |
| 146         | 260         | 149         | 302         | 152         | 346         | 156         | 393         | 161         | 441         | 166         | 492         |

**074 Charging Curve - No Reheat - All-Aluminum Coil - 581226-01**



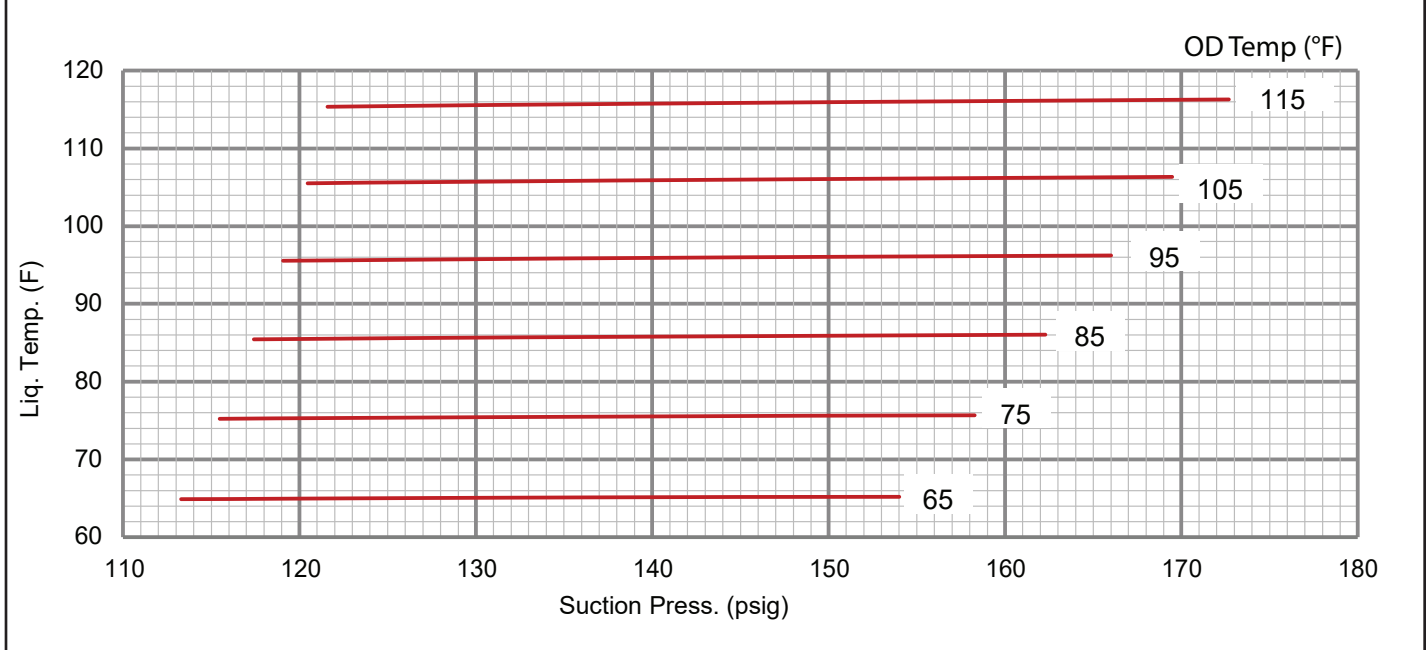
**TABLE 9**

**036 Normal Operating Pressures - Reheat - All-Aluminum Coil - 581267-01**

**Outdoor Coil Entering Air Temperature**

| 65°F        |             | 75°F        |             | 85°F        |             | 95°F        |             | 105°F       |             | 115°F       |             |
|-------------|-------------|-------------|-------------|-------------|-------------|-------------|-------------|-------------|-------------|-------------|-------------|
| Suct (psig) | Disc (psig) | Suct (psig) | Disc (psig) | Suct (psig) | Disc (psig) | Suct (psig) | Disc (psig) | Suct (psig) | Disc (psig) | Suct (psig) | Disc (psig) |
| 113         | 217         | 115         | 252         | 117         | 291         | 119         | 335         | 120         | 384         | 122         | 437         |
| 120         | 219         | 123         | 254         | 125         | 293         | 127         | 338         | 129         | 386         | 131         | 440         |
| 136         | 224         | 140         | 259         | 143         | 299         | 146         | 343         | 148         | 392         | 151         | 445         |
| 154         | 229         | 158         | 264         | 162         | 304         | 166         | 348         | 169         | 397         | 173         | 451         |

**036 Charging Curve - Reheat - All-Aluminum Coil - 581267-01**



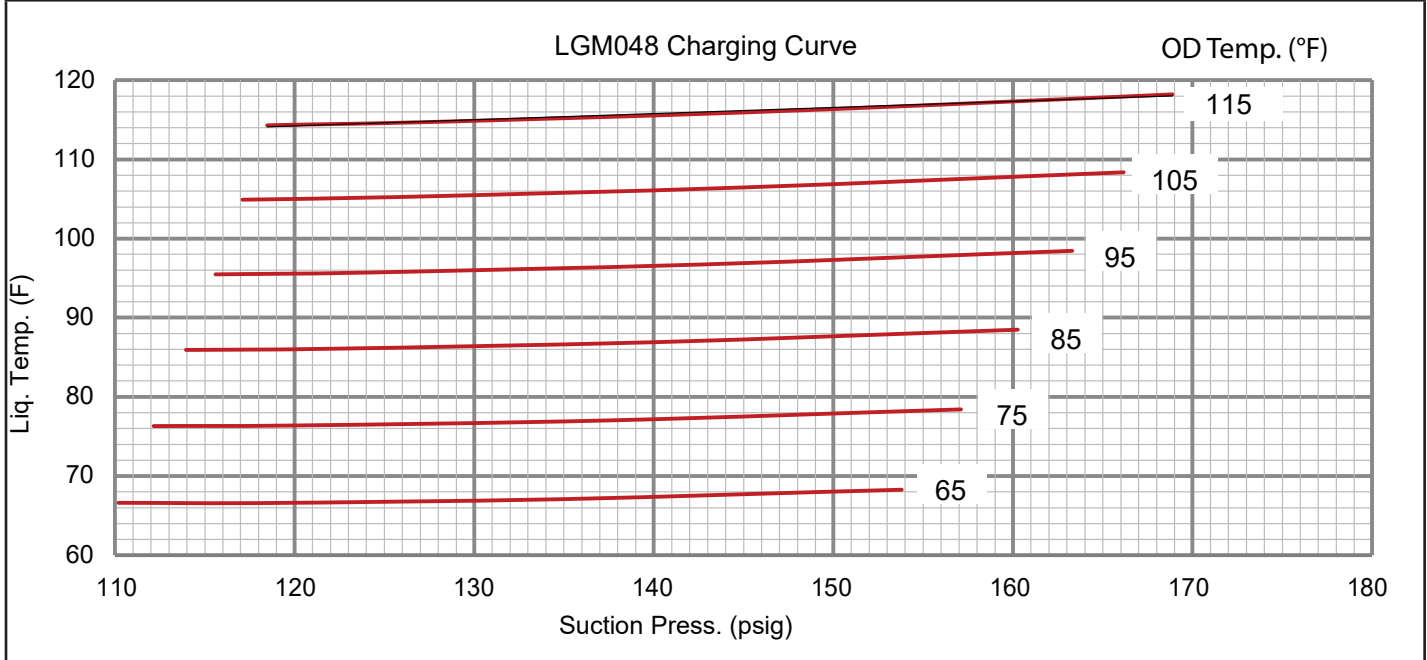
**TABLE 10**

**048 Normal Operating Pressures - Reheat - All-Aluminum Coil - 581268-01**

**Outdoor Coil Entering Air Temperature**

| 65°F        |             | 75°F        |             | 85°F        |             | 95°F        |             | 105°F       |             | 115°F       |             |
|-------------|-------------|-------------|-------------|-------------|-------------|-------------|-------------|-------------|-------------|-------------|-------------|
| Suct (psig) | Disc (psig) | Suct (psig) | Disc (psig) | Suct (psig) | Disc (psig) | Suct (psig) | Disc (psig) | Suct (psig) | Disc (psig) | Suct (psig) | Disc (psig) |
| 110         | 228         | 112         | 264         | 114         | 304         | 116         | 348         | 117         | 396         | 118         | 448         |
| 118         | 232         | 120         | 268         | 122         | 309         | 124         | 353         | 126         | 401         | 127         | 454         |
| 135         | 239         | 137         | 276         | 140         | 317         | 143         | 362         | 145         | 411         | 147         | 464         |
| 154         | 245         | 157         | 283         | 160         | 324         | 163         | 370         | 166         | 420         | 169         | 473         |

**048 Charging Curve - Reheat - All-Aluminum Coil - 581268-01**



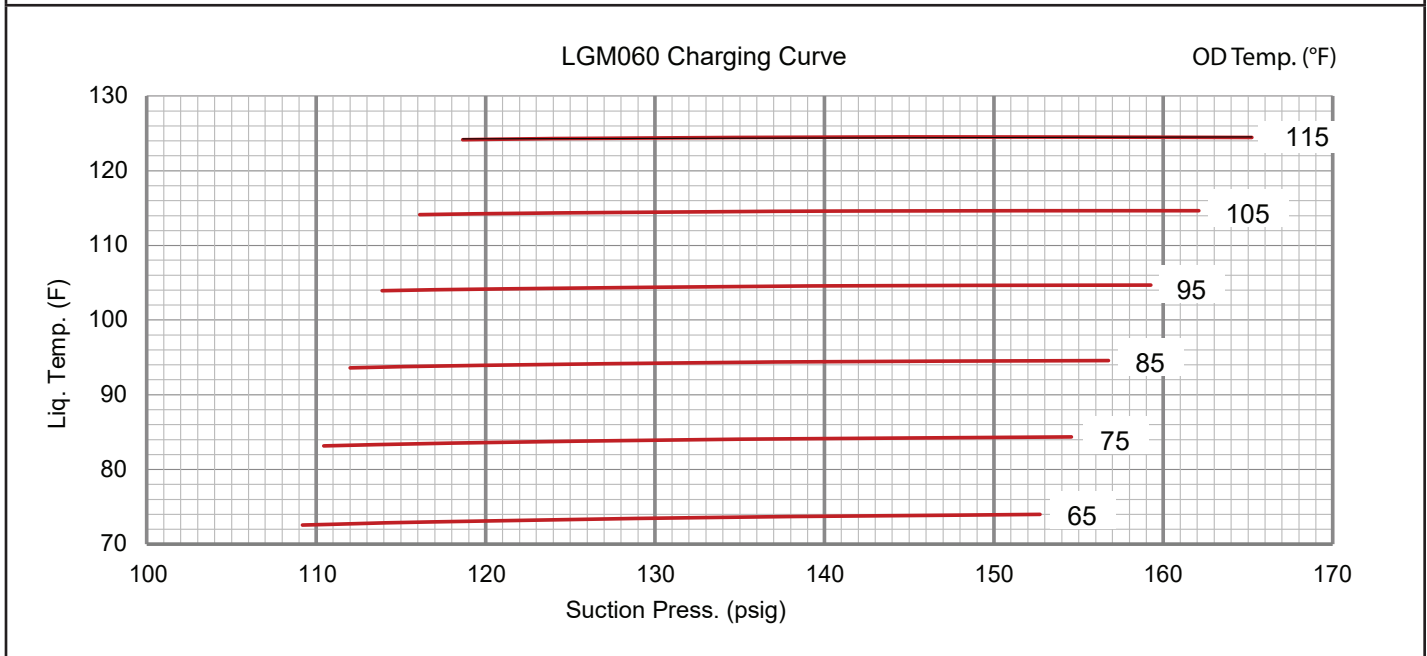
**TABLE 11**

**060 Normal Operating Pressures - Reheat - All-Aluminum Coil - 581269-01**

**Outdoor Coil Entering Air Temperature**

| 65°F        |             | 75°F        |             | 85°F        |             | 95°F        |             | 105°F       |             | 115°F       |             |
|-------------|-------------|-------------|-------------|-------------|-------------|-------------|-------------|-------------|-------------|-------------|-------------|
| Suct (psig) | Disc (psig) | Suct (psig) | Disc (psig) | Suct (psig) | Disc (psig) | Suct (psig) | Disc (psig) | Suct (psig) | Disc (psig) | Suct (psig) | Disc (psig) |
| 109         | 233         | 110         | 269         | 112         | 308         | 114         | 352         | 116         | 400         | 119         | 453         |
| 117         | 241         | 118         | 277         | 120         | 318         | 122         | 363         | 124         | 412         | 127         | 465         |
| 133         | 253         | 135         | 291         | 137         | 333         | 139         | 380         | 142         | 431         | 145         | 486         |
| 153         | 259         | 155         | 299         | 157         | 344         | 159         | 392         | 162         | 445         | 165         | 502         |

**060 Charging Curve - Reheat - All-Aluminum Coil - 581269-01**



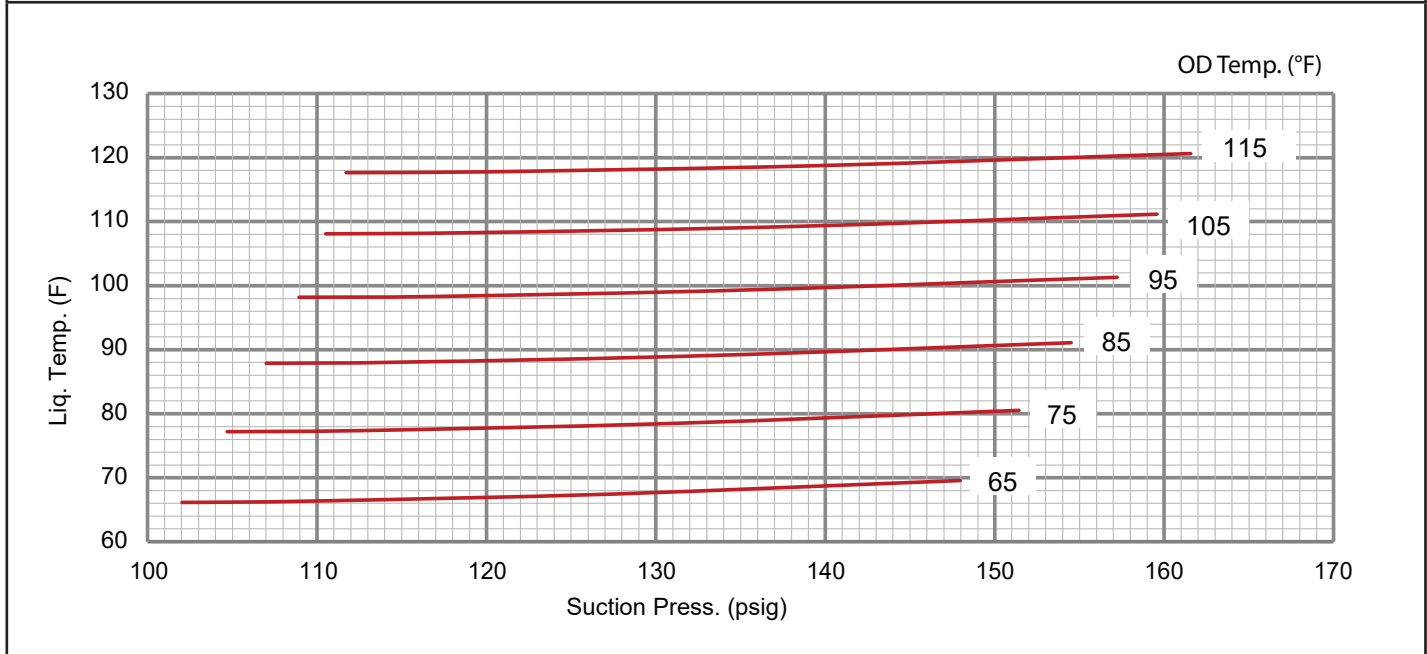
**TABLE 12**

**074 Normal Operating Pressures - Reheat - All-Aluminum Coil - 581270-01**

**Outdoor Coil Entering Air Temperature**

| 65°F        |             | 75°F        |             | 85°F        |             | 95°F        |             | 105°F       |             | 115°F       |             |
|-------------|-------------|-------------|-------------|-------------|-------------|-------------|-------------|-------------|-------------|-------------|-------------|
| Suct (psig) | Disc (psig) | Suct (psig) | Disc (psig) | Suct (psig) | Disc (psig) | Suct (psig) | Disc (psig) | Suct (psig) | Disc (psig) | Suct (psig) | Disc (psig) |
| 102         | 244         | 105         | 280         | 107         | 321         | 109         | 366         | 111         | 417         | 112         | 472         |
| 110         | 251         | 113         | 288         | 115         | 329         | 117         | 375         | 119         | 426         | 120         | 482         |
| 128         | 262         | 131         | 300         | 133         | 343         | 136         | 391         | 138         | 443         | 140         | 500         |
| 148         | 270         | 151         | 309         | 155         | 353         | 157         | 402         | 160         | 456         | 162         | 514         |

**074 Charging Curve - Reheat - All-Aluminum Coil - 581270-01**



## Prognostic & Diagnostic Sensors

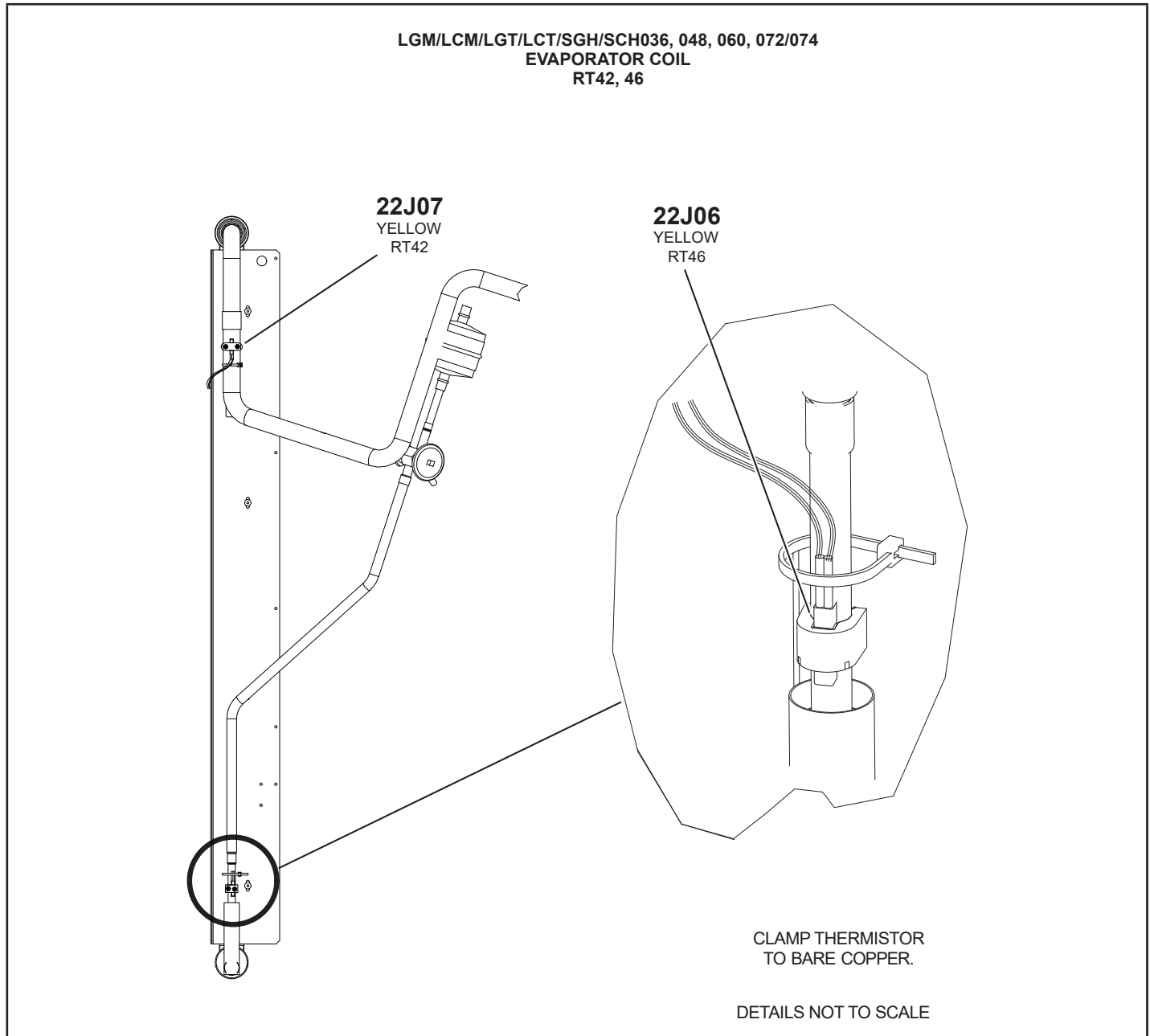
Units are equipped with four factory-installed thermistors (RT42, RT44, RT46, and RT48) located on different points on the refrigerant circuit.

The thermistors provide the Unit Controller with constant temperature readings of four specific locations on the refrigeration circuit. These temperatures are used as feedback in certain modes of unit operation. In addition, the Unit Controller uses these temperatures to initiate alarms such as loss of condenser or evaporator airflow and loss of charge.

Each thermistor must be specifically placed for proper unit operation and to initiate valid alarms. See TABLE 13 for proper locations.

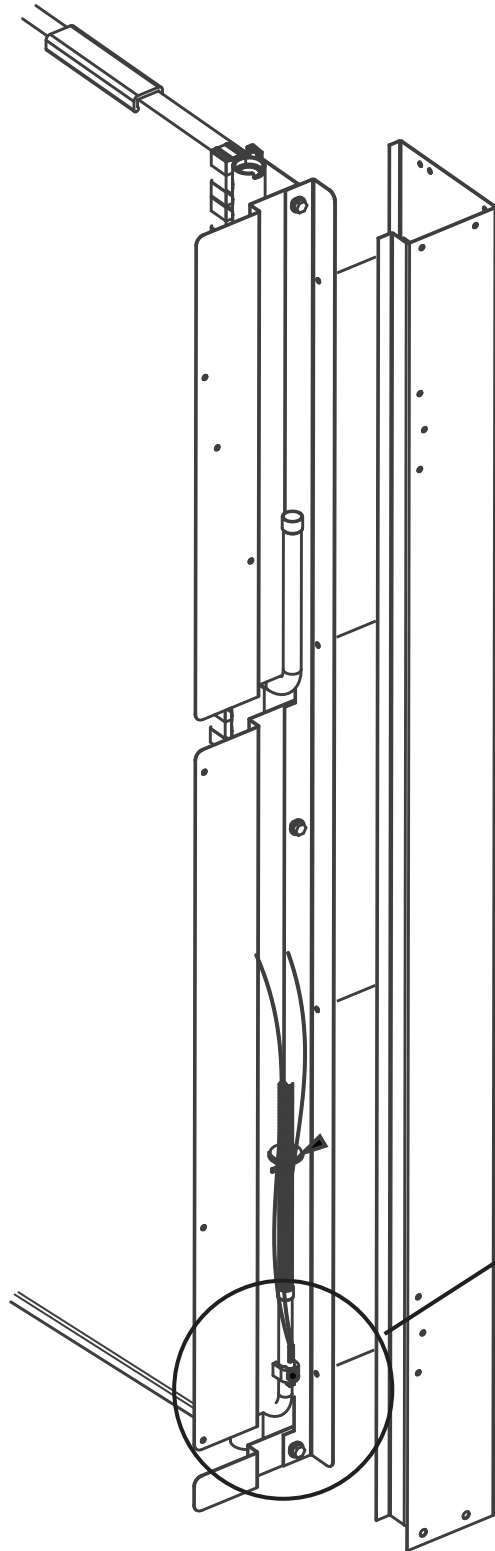
**TABLE 13**  
**THERMISTOR LOCATION**

| Sensor     | Figure    |
|------------|-----------|
| RT42, RT46 | FIGURE 25 |
| RT44       | FIGURE 26 |
| RT48       | FIGURE 27 |

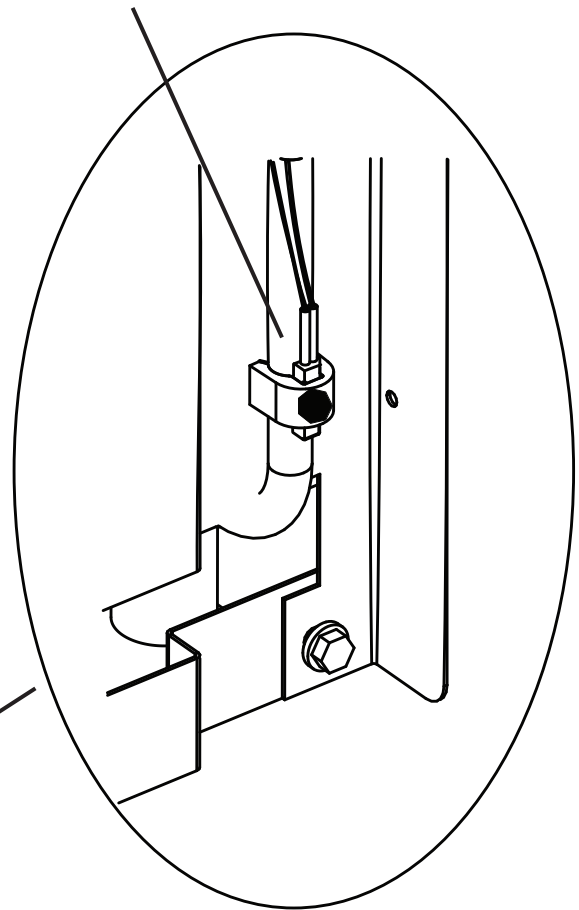


**FIGURE 25**

LGM/LCM036, 048, 060, 074U5  
CONDENSER COIL  
(RT44)



**22J09**  
YELLOW  
RT44



CLAMP THERMISTOR  
TO BARE COPPER.

DETAILS NOT TO SCALE

FIGURE 26

LCM/LGM036, 048, 060, 074  
CONDENSER COIL  
RT48

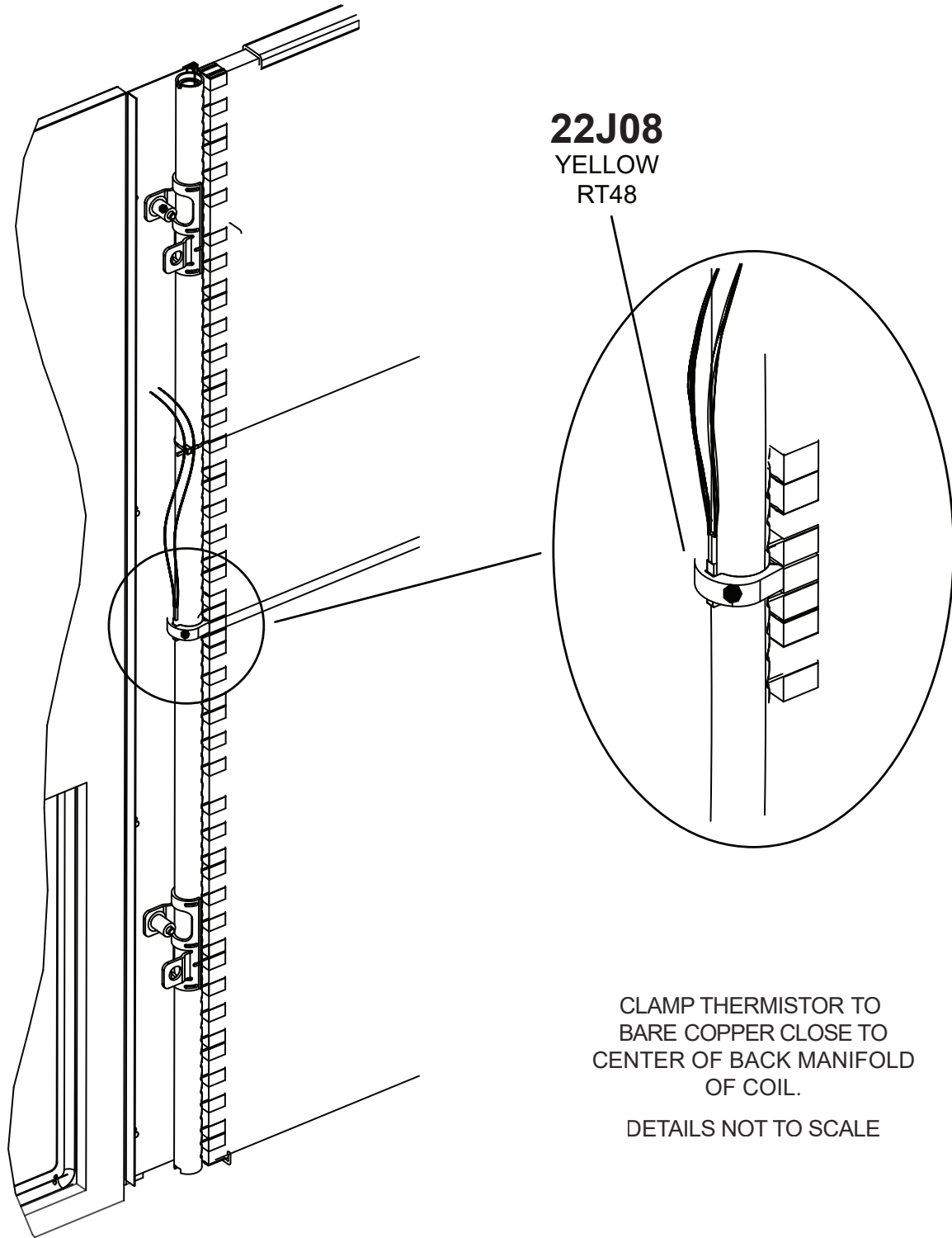


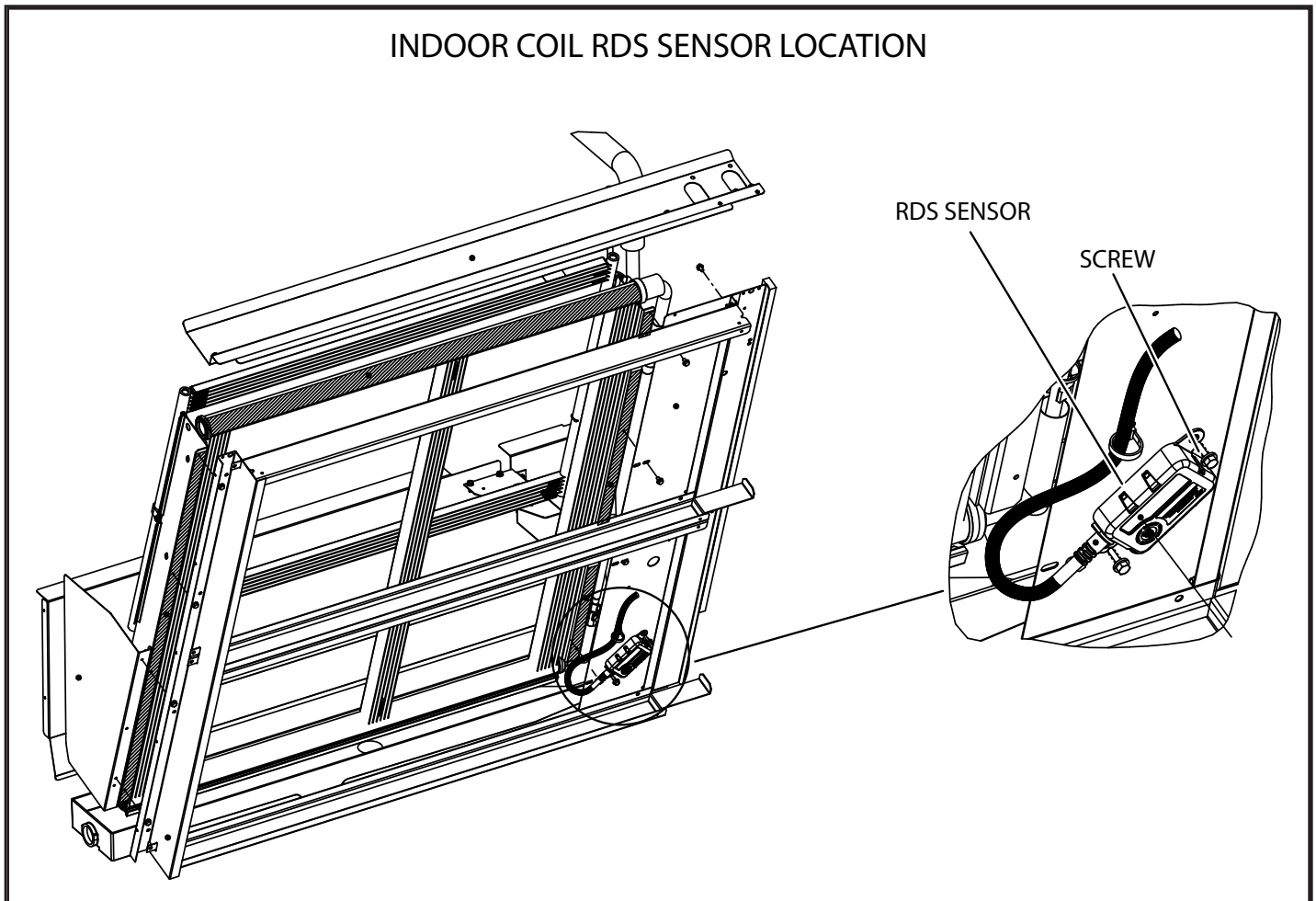
FIGURE 27

## RDS Sensors

Units are equipped with factory-installed RDS Sensors located on different points on the unit. The RDS sensors provide the Unit Controller with continuous readings for leaked refrigerant concentration levels and sensor health status (Good or Fault). These readings are used to modify unit operation to disperse the leaked refrigerant and to remove possible ignition sources. In addition, the Unit Controller uses these readings to initiate alarms to alert the operator of a refrigerant leak or faulty sensor(s).

Each sensor must be specifically placed for proper unit operation and to initiate valid alarms. To identify sensor locations see TABLE 14.

| Model      | Qty.      | Type              | Figure    |
|------------|-----------|-------------------|-----------|
| LGM036-074 | 2 sensors | INDOOR SENSOR     | FIGURE 28 |
|            |           | COMPRESSOR SENSOR | FIGURE 29 |
| LCM036-074 | 1 sensor  | INDOOR SENSOR     | FIGURE 28 |



**FIGURE 28**

COMPRESSOR RDS SENSOR LOCATION

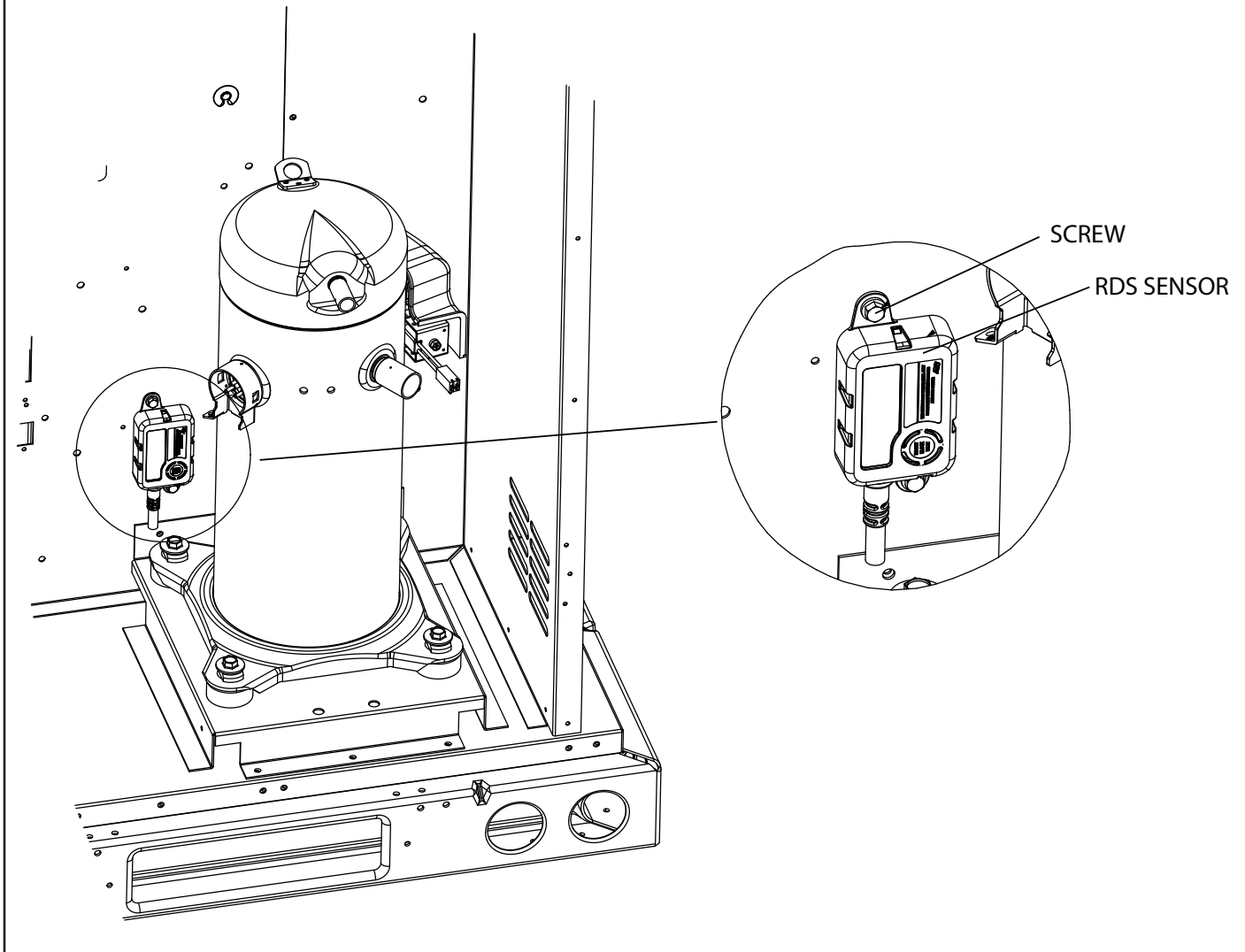


FIGURE 29

## Cooling Operation

### A-Two-Stage Thermostat

#### 1 - Economizer With Outdoor Air Suitable

##### Y1 Demand -

Compressor Off  
Blower Low Dampers Modulate

##### Y2 Demand -

Compressor Modulates Blower Low  
Dampers Full Open

**NOTE** - Compressor is energized after damper has been at full open for three minutes.

#### 2 - No Economizer or Outdoor Air Not Suitable

##### Y1 Demand -

Compressor Modulates  
Blower Low  
Dampers Minimum Position

##### Y2 Demand -

Compressor Modulates  
Blower High  
Dampers Minimum Position

### B-Three-Stage Thermostat OR Room Sensor

#### 1 - Economizer With Outdoor Air Suitable

##### Y1 Demand -

Compressors Off  
Blower Low Dampers Modulate

##### Y2 Demand -

Compressor Modulates Blower Low  
Dampers Full Open

**NOTE** - Compressor is energized after damper has been at full open for three minutes.

##### Y3 Demand -

Compressor Modulates Blower High  
Dampers Full Open

#### 2 - No Economizer or Outdoor Air Not Suitable

##### Y1 Demand -

Compressor Modulates  
Blower Low  
Dampers Minimum Position

##### Y2 Demand -

Compressor Modulates  
Blower Mid  
Dampers Minimum Position

##### Y3 Demand -

Compressor Modulates  
Blower High  
Dampers Minimum Position

### C-Zone Sensor

#### 1 - Economizer With Outdoor Air Suitable

##### Low Cooling Demand -

Compressor Off  
Blower Variable  
Dampers Modulate

##### High Cooling Demand -

Compressor Variable  
Blower Variable  
Dampers Full Open

**NOTE** - Compressor is energized after damper has been at full open for three minutes.

**NOTE** - Free cooling is locked out when a dehumidification demand is received. The unit operates in dehumidification mode as if the outdoor air is not suitable.

#### 2 - No Economizer or Outdoor Air Not Suitable

##### Any Demand -

Compressor Variable  
Blower Variable  
Damper Minimum Position

### D-Verify Proper Operation In Zone Sensor Mode

The Unit Controller (A55) communicates the appropriate frequency (speed) to the compressor inverter (A192) to match the cooling load. Because the cooling load varies, the Unit Controller provides a test mode to initiate a predictable compressor speed. Use the following mobile service app menu paths to change the compressor speed and verify discharge and suction pressures are changing appropriately. When the compressor speed increases, the discharge pressure will increase proportionately and the suction pressure will decrease proportionately. When the compressor speed decreases, the discharge pressure will decrease proportionately and the suction pressure will increase proportionately.

#### 036, 048, 060U

High speed compressor operation:

**SERVICE > TEST > COOL > COOL 3**

Intermediate speed compressor operation:

**SERVICE > TEST > COOL > COOL 2**

Low speed compressor operation

**SERVICE > TEST > COOL > COOL 1**

#### 074U Only

High speed compressor operation:

**SERVICE > TEST > COOL > COOL 4**

First intermediate speed compressor operation:

**SERVICE > TEST > COOL > COOL 3**

Second intermediate speed compressor operation:

**SERVICE > TEST > COOL > COOL 2**

Low speed compressor operation:

**SERVICE > TEST > COOL > COOL 1**

## Gas Heat Start-Up (LGM)

FOR YOUR SAFETY READ BEFORE LIGHTING

### ⚠ WARNING



Electric shock hazard. Can cause injury or death. Do not use this unit if any part has been under water. Immediately call a qualified service technician to inspect the unit and to replace any part of the control system and any gas control which has been under water.

### ⚠ WARNING



Danger of explosion. Can cause injury or product or property damage. If over heating occurs or if gas supply fails to shut off, shut off the manual gas valve to the appliance before shutting off electrical supply.

### ⚠ WARNING



Electric shock hazard. Can cause injury or death. Before attempting to perform any service or maintenance, turn the electrical power to unit OFF at disconnect switch(es). Unit may have multiple power supplies.

BEFORE LIGHTING smell all around the appliance area for gas. Be sure to smell next to the floor because some gas is heavier than air and will settle on the floor.

The gas valve may be equipped with either a gas control lever or gas control knob. Use only your hand to push the lever or turn the gas control knob. Never use tools. If the the lever will not move or the knob will not push in or turn by hand, do not try to repair it. Call a qualified service technician. Force or attempted repair may result in a fire or explosion.

### ⚠ WARNING



Danger of explosion. Can cause injury or death. Do not attempt to light manually. Unit has a direct spark ignition system.

This unit is equipped with an automatic spark ignition system. There is no pilot. In case of a safety shutdown, move thermostat switch to **OFF** and return the thermostat switch to **HEAT** to reset ignition control.

### ⚠ WARNING



Danger of explosion and fire. Can cause injury or product or property damage. You must follow these instructions exactly.

#### Turning On Gas To Unit

- 1 - Set thermostat to lowest setting.
- 2 - Turn off all electrical power to appliance.
- 3 - This appliance is equipped with an ignition device which automatically lights the burner. Do not try to light the burner by hand.
- 4 - Open or remove the control access panel.

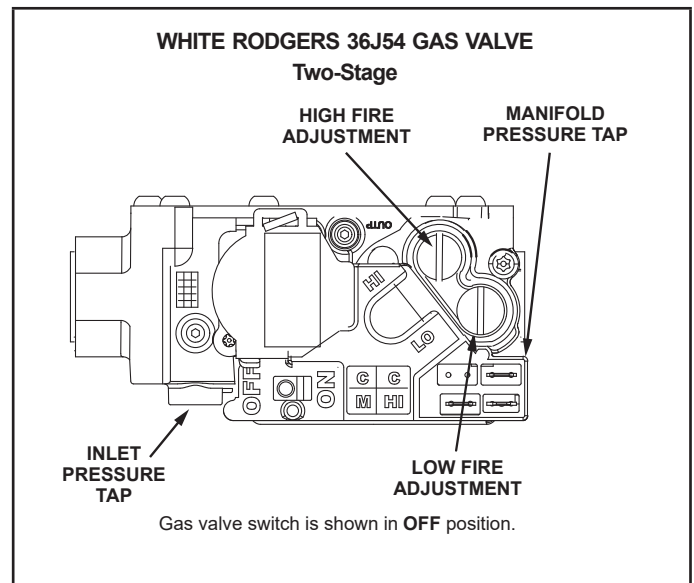


FIGURE 30

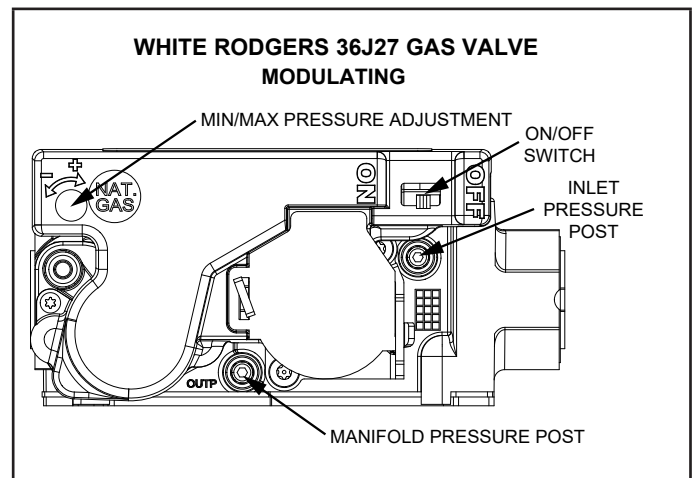


FIGURE 31

- 5 - Move gas valve switch to **OFF**. See FIGURE 30 and FIGURE 31.
- 6 - Wait five (5) minutes to clear out any gas. If you then smell gas, **STOP!** Immediately call your gas supplier from a neighbor's phone. Follow the gas supplier's instructions. If you do not smell gas, go to the next step.
- 7 - Move gas valve switch to **ON**. See FIGURE 30 and FIGURE 31.
- 8 - Close or replace the control access panel.
- 9 - Turn on all electrical power to appliance.
- 10 - Set thermostat to desired setting.

**NOTE** - When unit is initially started, steps 1 through 10 may need to be repeated to purge air from gas line.

- 11 - The ignition sequence will start.
- 12 - If the furnace does not light the first time (gas line not fully purged), it will attempt up to two more ignitions before locking out.
- 13 - If lockout occurs, repeat steps 1 through 10.
- 14 - If the appliance will not operate, follow the instructions "Turning Off Gas to Appliance" and call your service technician or gas supplier.

#### Turning Off Gas to Unit

- 1 - If using an electromechanical thermostat, set to the lowest setting.
- 2 - Before performing any service, turn off all electrical power to the appliance.
- 3 - Open or remove the control access panel.
- 4 - Move gas valve switch to **OFF**.
- 5 - Close or replace the control access panel.

|  |
|--|
|  <b>WARNING</b>   |
|  <b>Danger of explosion. Can cause injury or death. Do not attempt to light manually. Unit has a direct spark ignition system.</b> |

#### Gas Heating Operation

#### A-Heating Sequence of Operation

The gas heating sequence of operation contains 3 distinct phases: ignition, heating demand, and termination.

#### Ignition – Two-Stage and Modulating

- 1 - Thermostat initiates heating demand (W1).
- 2 - CORE transmits W1 demand signal to the Direct Spark Ignition (DSI) control. For Modulating systems, CORE transmits an additional signal, Modulating Gas Valve (MGV) Position, to the DSI control which passes through to the MGv.

- 3 - DSI control activates Combustion Air Inducer (CAI) at low speed.
- 4 - CAI pressure switch proves inducer operation before DSI control opens gas valve.
- 5 - After a 30 second pre-purge time, DSI control energizes the spark ignitor and opens the gas valve to Low Fire (Two-Stage) or minimum position (Modulating).
- 6 - The spark then ignites the gas, and flame is verified by flame sensor.

**NOTE** - If flame is not detected, the DSI control will close the gas valve and repeat steps 4 and 5 two more times.

- 7 - After Gas Blower On Delay expires, CORE starts indoor blower operation.

#### Heating Demand – Two-Stage

- 1 - CORE operates indoor blower at the Blower Heating High CFM Setpoint (refer to TABLE 4).

**NOTE** - For units with 12th character "P" (208/230V-1phase), the indoor blower operates at Blower Heating Low CFM Set point during a W1 demand and at Blower Heating High CFM Set point during a W2 demand.

- 2 - When thermostat initiates W2 demand, CORE transmits W2 signal to DSI control.
- 3 - DSI control opens the gas valve to High Fire and changes CAI speed from low to high.

#### Heating Demand – Modulating

- 1 - CORE operates indoor blower at Blower Heating Low CFM setpoint (refer to TABLE 4).
- 2 - MGv Position is consistently updated by the CORE during heating demand.
  - a. CORE monitors the Discharge Air Temperature (DAT) sensor and compares its value to the setpoint.
  - b. CORE calculates a new MGv Position.
  - c. CORE transmits new MGv Position to MGv which responds accordingly.
  - d. Steps a) thru c) are repeated until heating demand has been satisfied.
- 3 - Increasing MGv Position (minimum, moving toward maximum).
  - a. When CORE increases the MGv Position above programmed value, CORE outputs W2 signal to the DSI control.
  - b. DSI control changes CAI speed from low to high.
  - c. CORE changes indoor blower operation to Blower Heating High CFM setpoint (refer to TABLE 4).
- 4 - Decreasing MGv Position (maximum, moving toward minimum).

- a. When CORE decreases MGV Position to minimum and CORE holds MGV in minimum position for preset time period, CORE removes W2 signal to DSI control.
- b. DSI control changes CAI speed from high to low.
- c. CORE changes indoor blower operation to Blower Heating Low CFM setpoint (refer to TABLE 4).

**Extinguishment – Two-Stage and Modulating**

- 1 - When thermostat demand is satisfied, heating demands (W1, W2) are removed from CORE.
- 2 - CORE removes any active demand signals (W1, W2) to DSI control. For Modulating systems, the CORE removes the MGV Position signal too.
- 3 - DSI control closes the gas valve.
- 4 - DSI control maintains CAI operation for post purge period (45 seconds), then shuts off CAI.
- 5 - CORE maintains indoor blower operation until Gas Blower Off Delay expires, then CORE shuts off the indoor blower.

**B-Ignition Control Diagnostic LEDs**

The table below refers to several components. The components and wiring diagram key numbers are: DSI Control Board (A3); Gas Valve (GV1 or GV4); Primary Limit Switch (S10); Combustion Air Blower Proofing Switch (S18); Rollout Switch (S47). Refer to the unit wiring diagram for further details.

**TABLE 15**

**IGNITION CONTROL HEARTBEAT LED STATUS**

| LED Flashes | Indicates  |
|-------------|--|
| Slow Flash  | Normal Operation – No call for heat                                  |
| Fast Flash  | Normal Operation - call for heat                                     |
| Steady Off  | Internal control board fault or no power                             |
| Steady On   | Control board failure  |
| 1 Flash     | Rollout Switch open  |
| 2 Flashes   | Limit Switch open or opened multiple times during one heating demand |
| 3 Flashes   | Pressure Switch open with CAI ON                                     |
| 4 Flashes   | Control lockout – failed to detect or sustain flame                  |
| 5 Flashes   | Flame sensed and gas valve not energize                              |
| 6 Flashes   | Pressure Switch closed with CAI OFF                                  |
| 7 Flashes   | Not used   |
| 8 Flashes   | Pressure switch opened repeatedly during heating demand              |

**Gas Heating Checks and Adjustments**

**A-Gas Flow**

To check for proper gas flow, determine the Btu input from the unit rating plate. Divide this input rating by the Btu per cubic feet of available gas. Result is the required number of cubic feet per hour. Determine the flow of gas through the gas meter for two minutes and multiply by 30 to get the hourly flow of gas.

**B-Supply Gas Pressure**

Supply pressure should be checked with unit firing at maximum rate. For Natural Gas, supply pressure should be maintained in accordance with the specified minimum and maximum supply pressures on the unit rating plate.

For LP/propane, a natural gas to LP/propane gas changeover kit is required to convert the unit in the field. Refer to installation instructions provided with changeover kit for conversion procedure along with propane minimum and maximum supply pressures.

**NOTE** - On multiple unit installations, each unit should be checked separately, with and without other units operating. Supply pressures on both single and multiple unit installations must fall within range listed on the rating plate.

**C-Supply Gas Pressure Measurement**

- 1 - Shut off the manual main supply valve (field furnished) when installing or removing the measuring device (Steps 2 and 5).
- 2 - Connect the measuring device based upon type of gas valve.

For White Rodgers 36J54 valve (FIGURE 30), supply pressure is accessed by removing 1/8" hex screw. Remove the 1/8" hex screw and install a 1/8" fitting with hose barb. Connect tubing from the barbed fitting and route to measuring device to measure supply pressure.

For White Rodgers 36J27 valve (FIGURE 31), locate the 5/16" inlet pressure post on top of the valve. Using a 3/32" hex wrench, rotate pressure tap screw one rotation counter-clockwise. Connect a piece of 5/16" I.D. tubing over the post and route to measuring device. Open manual main supply valve.

- 3 - Ignite unit and let run for 5 minutes to allow for steady state conditions.
- 4 - After allowing unit to stabilize for 5 minutes, record supply pressure.

- 5 - Shut unit off and remove measuring device, tubing, or fittings as soon as an accurate reading has been obtained.

For White Rodgers 36J54 valve (FIGURE 30), remove supply pressure barbed fitting and reinstall the 1/8" hex screw.

For White Rodgers 36J27 valve (FIGURE 31), remove tubing from the post. Then using 3/32" hex wrench, rotate the inlet pressure tap screw clockwise to seal the pressure port.

#### **D-Manifold Pressure Measurement and Adjustment**

- 1 - Shut off the manual main supply valve (field furnished) when installing or removing the measuring device (Steps 2 and 7).
- 2 - Connect the measuring device based upon the type of gas valve.

For White Rodgers 36J54 valve (FIGURE 30) manifold pressure, remove the 1/8" hex screw, install 1/8" fitting with hose barb, connect hose from barb to "+" side of measuring device.

For White Rodgers 36J27 valve (FIGURE 31) manifold pressure, locate the 5/16" manifold pressure post on top of the valve. Using a 3/32" hex wrench, rotate the outlet pressure tap screw one rotation counter-clockwise. Place 5/16" I.D. tubing over post and route to measuring device.
- 3 - Ignite unit and let run for 5 minutes to allow for steady state conditions. If unit has 2 heating inputs, start on higher input.
- 4 - After allowing unit to stabilize for 5 minutes, record manifold pressure. Compare measurement to the unit nameplate values.

**NOTE** - For elevations higher than 2001 feet above sea level, see High Altitude Adjustment section for details.

- 5 - If necessary, adjust manifold pressure. FIGURE 30 and FIGURE 31 show adjustment screw(s) locations.
- 6 - Repeat steps 3, 4 and 5 on lower input.
- 7 - Shut unit off and remove measuring device as soon as accurate reading has been obtained.

For White Rodgers 36J54 valve (FIGURE 30), remove 1/8" fitting with hose barb and reinstall 1/8" hex screw.

For White Rodgers 36J27 valve (FIGURE 31), remove tubing from the post. Then using 3/32" hex wrench, rotate the manifold pressure tap screw clockwise to seal the pressure port. Start unit and perform leak check. Seal leaks if found.

**NOTE** - White Rodgers offers a Pressure Check Kit (69M1701) which includes 5/16" ID tubing, 3/32" hex wrench, and 1/4" to 5/16" tubing connector.

#### **E-High Altitude Adjustments**

Units in Canada and US may be fired at full input up to 2000 feet (610m) above sea level. Above 2000 feet (610m), manifold pressures must be adjusted.

In Canada, certification for installation at altitudes over 4500 feet (1372m) above sea level is the jurisdiction of local authorities. Lennox recommends reducing input (de-rate) by two percent for each additional 1000 feet above 4,500 feet. Refer to TABLE 16 for guidance.

In US, the heating input shall be reduced (de-rated) by two percent per 1000 feet above sea level. Refer to TABLE 17 for guidance.

Once any high-altitude adjustments have been completed, locate the high-altitude conversion sticker in the unit literature bag. Fill out the conversion sticker and affix next to the unit nameplate.

**NOTE** - For heating values above 1000 Btu/cu. ft., Lennox recommends verifying the reduced input rate using local heating values and gas flow rate as detailed in section A-Gas Flow.

**TABLE 16****CANADA – NATURAL GAS MANIFOLD PRESSURES  
[inch w.c. (kPa)]**

| Altitude in Feet<br>(Meters)        | Low (Minimum)<br>Input Rate | High (Maximum)<br>Input Rate |
|-------------------------------------|-----------------------------|------------------------------|
| 2001 – 4500<br>(610 – 1372)         | See unit nameplate          |                              |
| 4501-5500<br>(1372–1676)            | 1.6<br>(0.40)               | 2.8<br>(0.70)                |
| 5501-6500<br>(1677–1981)            | 1.5<br>(0.37)               | 2.7<br>(0.67)                |
| 6501-7500<br>(1981–2286)            | 1.4<br>(0.35)               | 2.6<br>(0.65)                |
| Fuel heating value = 1000 btu/cu ft |                             |                              |

**TABLE 17****US – NATURAL GAS MANIFOLD PRESSURES  
[inch w.c. (kPa)]**

| Altitude in Feet<br>(Meters)        | Low (Minimum)<br>Input Rate | High (Maximum)<br>Input Rate |
|-------------------------------------|-----------------------------|------------------------------|
| 2001 – 4500<br>(610 – 1372)         | See unit nameplate          |                              |
| 4501-5000<br>(1372–1524)            | 1.7<br>(0.42)               | 3.0<br>(0.75)                |
| 5001-6000<br>(1524–1829)            | 1.6<br>(0.40)               | 2.8<br>(0.70)                |
| 6001-7000<br>(1829–2134)            | 1.5<br>(0.37)               | 2.7<br>(0.67)                |
| 7001–8000<br>(2134–2438)            | 1.4<br>(0.35)               | 2.6<br>(0.65)                |
| Fuel heating value = 1000 btu/cu ft |                             |                              |

**F-High Altitude Adjustments – ULNOx Units**

The Ultra Low NOx units are approved for installations from 0-4500 ft above sea level. No modifications are required. Above 2000 ft, the furnace will naturally de-rate approximately 10%.

**Electric Heat Start-Up (LCM Units)**

Optional electric heat will stage on and cycle with thermostat demand. See electric heat wiring diagram on unit for sequence of operation.

**SCR Electric Heat Controller (LCM Units)**

Optional factory-installed SCR (A38) will provide small amounts of power to the electric heat elements to efficiently maintain warm duct air temperatures when there is no heating demand. The SCR maintains duct air temperature based on input from a field-provided and installed thermostat (A104) and duct sensor (RT20). SCR is located in the compressor section on the left wall. Use only with a thermostat or specified DDC control system.

Use the instructions provided with the thermostat to set DIP switches as follows: S1 On, S2 Off, S3 Off. Use the instructions provided with the duct sensor to install sensor away from electric element radiant heat and in a location where discharge air is a mixed average temperature.

Once power is supplied to unit, zero SCR as follows:

- 1 - Adjust thermostat (A104) to minimum position.
- 2 - Use a small screwdriver to slowly turn the ZERO potentiometer on the SCR until the LED turns solid red.
- 3 - Very slowly adjust the potentiometer the opposite direction until the LED turns off.

## Hot Gas Reheat Start-Up and Operation

### General

Hot gas reheat units provide a dehumidifying mode of operation. These units contain a reheat coil adjacent to and downstream of the evaporator coil. Reheat coil solenoid valve, L14, routes hot discharge gas from the compressor to the reheat coil. Return air pulled across the evaporator coil is cooled and dehumidified; the reheat coil adds heat to supply air. See FIGURE 32 for reheat refrigerant routing and FIGURE 33 for standard cooling refrigerant routing.

### L14 Reheat Coil Solenoid Valve

When Unit Controller input (Unit Controller J298-5 or J299-8) indicates room conditions require dehumidification, L14 reheat valve is energized (Unit Controller P269-3) and refrigerant is routed to the reheat coil.

### Reheat Setpoint

Reheat is factory-set to energize when indoor relative humidity rises above 60% (default). The reheat setpoint can be adjusted by changing mobile service app *Settings* - *Control* menu. A setting of 100% will operate reheat from an energy management system digital output. The reheat setpoint can also be adjusted using an optional Network Control Panel (NCP).

Reheat will terminate when the indoor relative humidity falls 3% (57% default) or the digital output de-energizes. The reheat deadband can be adjusted at *Settings* - *Control* menu.

### Check-Out

Test reheat operation using the following procedure.

- 1 - Make sure reheat is wired as shown in wiring section.
- 2 - Make sure unit is in local thermostat mode.
- 3 - Use mobile service app menu path to select **SERVICE > TEST > DEHUMIDIFIER**.

*The blower, compressor, and reheat valve should be energized. Pressure can be checked on the reheat line pressure tap. Pressure on the reheat line should match discharge pressure closely in reheat mode.*

### Default Reheat Operation

During reheat mode free cooling is locked out.

### A-Thermostat Mode With 24V Humidistat

No Y1 demand but a call for dehumidification:

Compressor operates at 100%, blower and outdoor fan modulate to maintain indoor coil and discharge air temperatures, reheat valve is energized.

Y1 demand:

Compressor is modulating, blower is on low, and the reheat valve is de-energized.

Y2 demand:

Compressor is modulating, blower is on high, reheat valve is de-energized.

### B-Thermostat Mode With Zone RH Sensor

No Y1 demand but a call for dehumidification:

Compressor modulates based on zone relative humidity, blower and outdoor fan modulate to maintain indoor coil and discharge air temperatures, reheat valve is energized.

Y1 and dehumidification demand:

Compressor is modulating, blower is on low, and the reheat valve is de-energized.

Y2 and dehumidification demand:

Compressor is modulating, blower is on high, reheat valve is de-energized.

### C-Zone Sensor Mode With Humidistat

No cooling demand but a call for dehumidification:

Compressor operates at 100%, blower and outdoor fan modulate to maintain indoor coil and discharge air temperatures, reheat valve is energized.

Cooling and dehumidification demand:

Compressor is modulating, blower is modulating, reheat valve is de-energized.

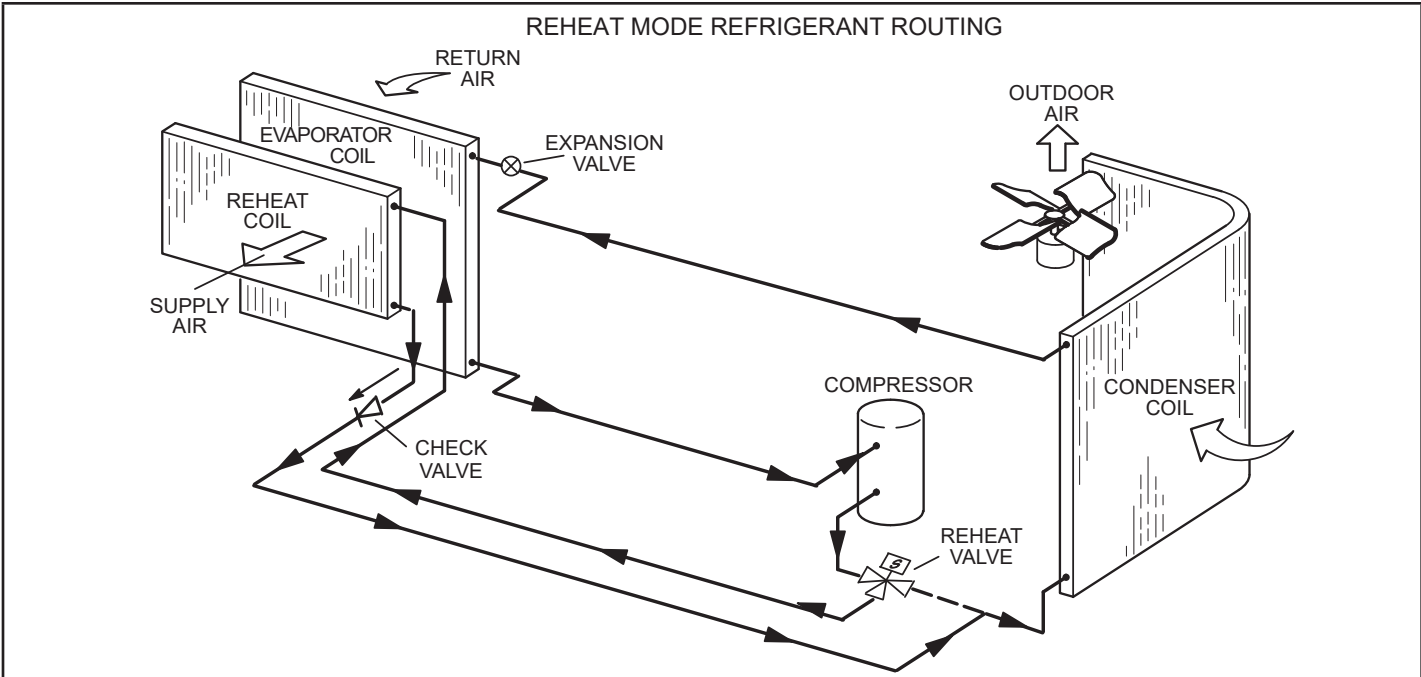
### D-Zone Sensor Mode With Zone RH Sensor

No cooling demand but a call for dehumidification:

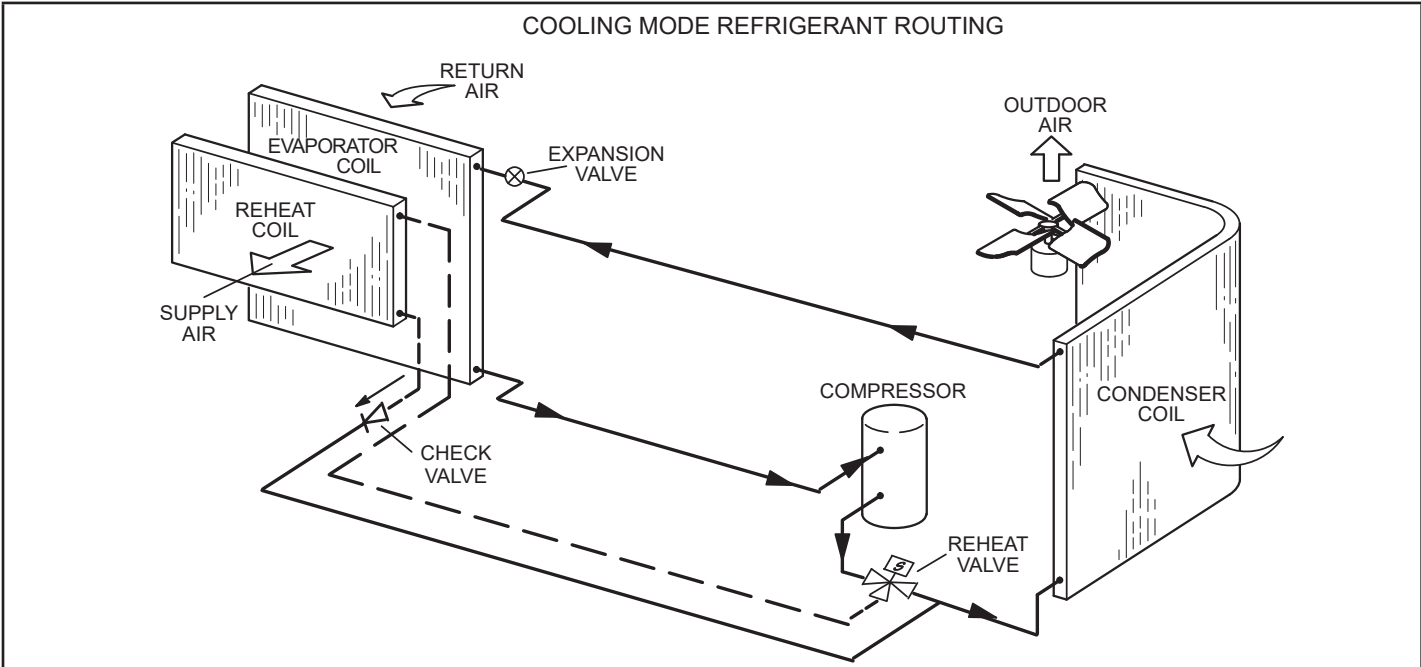
Compressor modulates based on zone relative humidity, blower and outdoor fan modulate to maintain indoor coil and discharge air temperatures, reheat valve is energized.

Cooling and dehumidification demand:

Compressor is modulating, blower is modulating, and the reheat valve is de-energized.



**FIGURE 32**



**FIGURE 33**

## Preventative Maintenance / Repair

### IMPORTANT MAINTENANCE / REPAIR SAFETY INSTRUCTIONS

Prior to beginning work on systems containing FLAMMABLE REFRIGERANTS, safety checks are necessary to ensure that the risk of ignition is minimized.

Work shall be undertaken under a controlled procedure to minimize the risk of a flammable gas or vapor being present while the work is being performed.

All maintenance staff and others working in the local area shall be instructed on the nature of work being carried out. Work in confined spaces shall be avoided.

The area shall be checked with an appropriate refrigerant detector prior to and during work, to ensure the technician is aware of potentially toxic or flammable atmospheres. Ensure that the leak detection equipment being used is suitable for use with all applicable refrigerants, i.e. non-sparking, adequately sealed or intrinsically safe.

If any hot work is to be conducted on the refrigerating equipment or any associated parts, appropriate fire extinguishing equipment shall be available to hand. Have a dry powder or CO2 fire extinguisher adjacent to the charging area.

No person carrying out work in relation to a REFRIGERATING SYSTEM which involves exposing any pipe work shall use any sources of ignition in such a manner that it may lead to the risk of fire or explosion. All possible ignition sources, including cigarette smoking, should be kept sufficiently far away from the site of installation, repairing, removing and disposal, during which refrigerant can possibly be released to the surrounding space. Prior to work taking place, the area around the equipment is to be surveyed to make sure that there are no flammable hazards or ignition risks. "No Smoking" signs shall be displayed.

Where electrical components are being changed, they shall be fit for the purpose and to the correct specification. At all times, the manufacturer's maintenance and service guidelines shall be followed. If in doubt, consult the manufacturer's technical department for assistance.

Repair and maintenance to electrical components shall include initial safety checks and component inspection procedures. If a fault exists that could compromise safety, then no electrical supply shall be connected to the circuit until it is satisfactorily dealt with. If the fault cannot be corrected immediately but it is necessary to continue operation, an adequate temporary solution shall be used. This shall be reported to the owner of the equipment so all parties are advised.

Initial safety checks shall include:

- that capacitors are discharged: this shall be done in a safe manner to avoid possibility of sparking
- that no live electrical components and wiring are exposed while charging, recovering or purging the system

- that there is continuity of earth bonding

The following checks shall be applied to installations using FLAMMABLE REFRIGERANTS:

- the actual REFRIGERANT CHARGE is in accordance with the room size within which the refrigerant containing parts are installed;
- the ventilation machinery and outlets are operating adequately and are not obstructed;
- if an indirect refrigerating circuit is being used, the secondary circuit shall be checked for the presence of refrigerant;
- marking to the equipment continues to be visible and legible. Markings and signs that are illegible shall be corrected;
- refrigerating pipe or components are installed in a position where they are unlikely to be exposed to any substance which may corrode refrigerant containing components, unless the components are constructed of materials which are inherently resistant to being corroded or are suitably protected against being so corroded.

During repairs to sealed electrical components, the components shall be replaced. Replacement parts shall be in accordance with the manufacturer's specifications.

During repairs to intrinsically safe components, the components must be replaced. Replace components only with parts specified by the manufacturer. Other parts may result in the ignition of refrigerant in the atmosphere from a leak.

The unit should be inspected once a year by a qualified service technician.

### WARNING



Electric shock hazard. Can cause injury or death. Before attempting to perform any service or maintenance, turn the electrical power to unit OFF at disconnect switch(es). Unit may have multiple power supplies.

### CAUTION

Label all wires prior to disconnection when servicing controls. Wiring errors can cause improper and dangerous operation. Verify proper operation after servicing.

#### A-Filters

Units are equipped with temporary filters which must be replaced prior to building occupation. Use four 20 X 20 X 2" (508 X 508 X 51mm) filters. Refer to local codes or appropriate jurisdiction for approved filters.

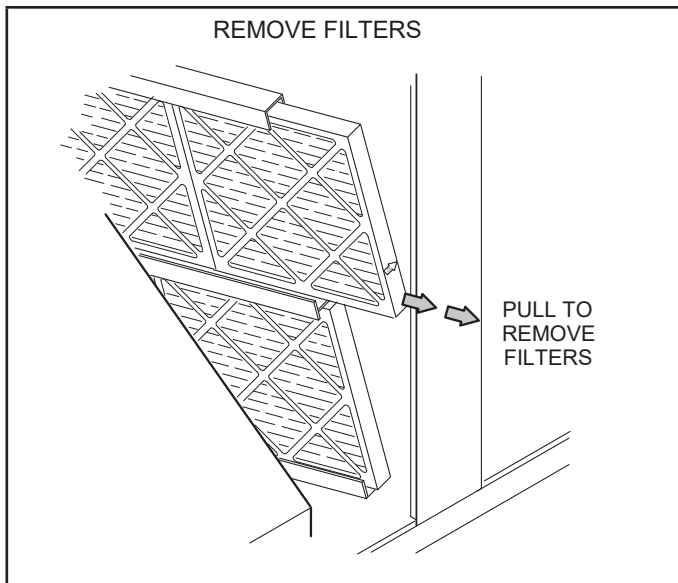


FIGURE 34

## WARNING

Units are shipped from the factory with temporary filters. Replace filters before building is occupied. Damage to unit could result if filters are not replaced with approved filters. Refer to appropriate codes.

Approved filters should be checked monthly and replaced when necessary. Take note of air flow direction marking on filter frame when reinstalling filters. See FIGURE 34.

**NOTE** - Filters must be U.L.C. certified or equivalent for use in Canada.

### B-Lubrication

All motors are lubricated at the factory. No further lubrication is required.

### C-Burners

Periodically examine burner flames for proper appearance during the heating season. Before each heating season examine the burners for any deposits or blockage which may have occurred.

Clean burners as follows:

- 1 - Turn off both electrical power and gas supply to unit.
- 2 - Remove blower access panel.
- 3 - Remove top burner box panel.
- 4 - Remove screws securing burners to burner support and lift the individual burners or the entire burner assembly from the orifices. See FIGURE 35. Clean as necessary.
- 5 - Locate the ignitor under the right burner. Check ignitor spark gap with appropriately sized twist drills or feeler gauges. See FIGURE 36.
- 6 - Replace burners and screws securing burner. See FIGURE 37.

## WARNING



Danger of explosion. Can cause injury or death. Do not overtighten main burner mounting screws. Snug tighten only.

7 - Replace access panel.

8 - Restore electrical power and gas supply. Follow lighting instructions attached to unit and use inspection port in access panel to check flame.

### BURNER BOX ASSEMBLY

REMOVE INDIVIDUAL BURNERS ON OLDER UNITS; REMOVE THE ENTIRE BURNER ASSEMBLY ON NEWER UNITS.

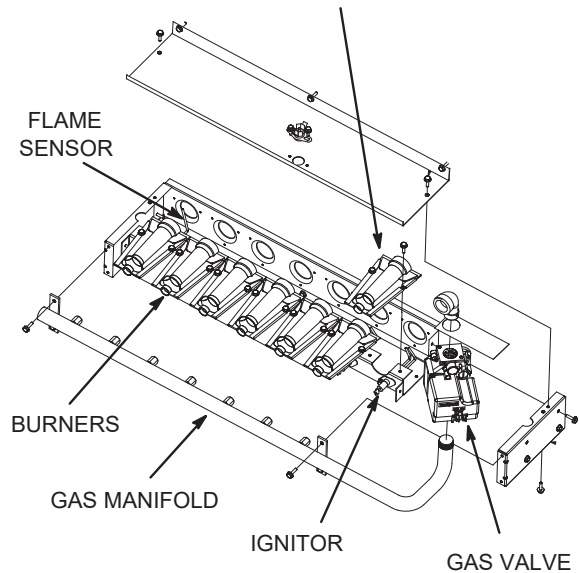


FIGURE 35

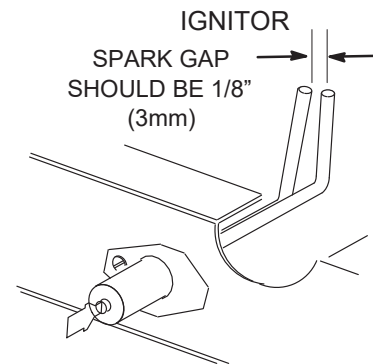


FIGURE 36

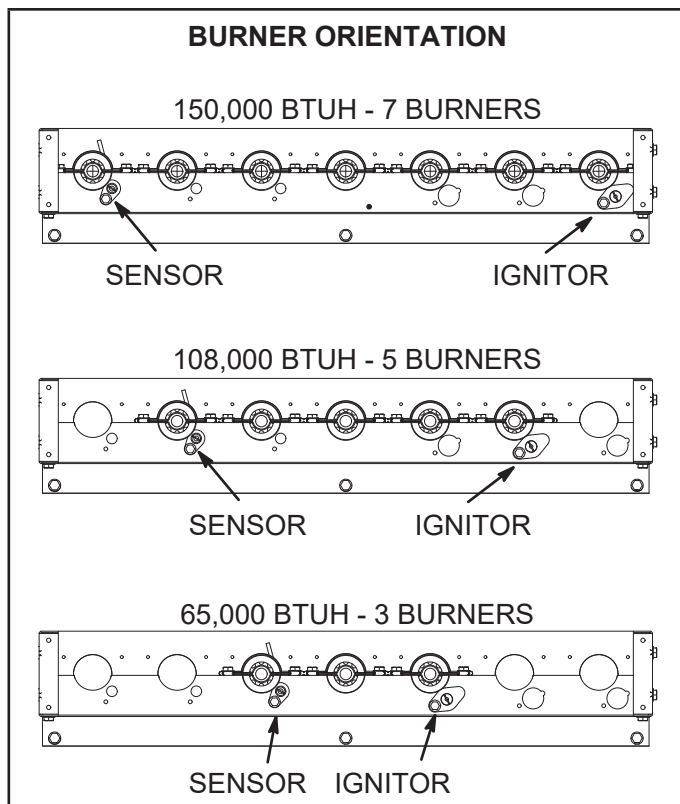


FIGURE 37

#### D-Combustion Air Inducer (Gas Units)

A combustion air proving switch checks combustion air inducer operation before allowing power to the gas controller. Gas controller will not operate if inducer is obstructed.

Under normal operating conditions, the combustion air inducer wheel should be checked and cleaned prior to the heating season. However, it should be examined periodically during the heating season to establish an ideal cleaning schedule.

Clean combustion air inducer as follows:

- 1 - Shut off power supply and gas to unit.
- 2 - Remove the mullion on the right side of the heat section.
- 3 - Disconnect pressure switch air tubing from combustion air inducer port.
- 4 - Remove and retain screws securing combustion air inducer to flue box. Remove vent connector. See FIGURE 38.
- 5 - Clean inducer wheel blades with a small brush and wipe off any dust from housing. Take care not to damage exposed fan blades. Clean accumulated dust from front of flue box cover.
- 6 - Return combustion air inducer motor and vent connector to original location and secure with retained screws. It is recommended that gaskets be replaced during reassembly.

7 - Replace mullion.

8 - Clean combustion air inlet louvers on blower access panel using a small brush.

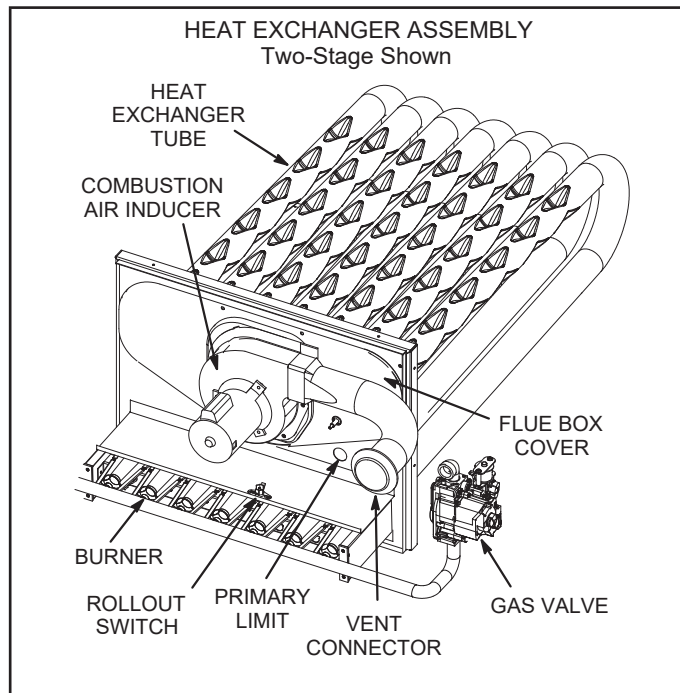


FIGURE 38

#### E-Flue Box (Gas Units)

Remove flue box cover only when necessary for equipment repair. Clean inside of flue box cover and heat exchanger tubes with a wire brush when flue box cover has to be removed. Install a new flue box cover gasket and replace cover. Make sure edges around flue box cover are tightly sealed.

#### F-Limit Control Switch (S10)

Limit controls are factory-set and are not adjustable. The primary limit is located to the right of the combustion air inducer. See FIGURE 38.

#### G-Combustion Air Pressure Switch (S18)

This pressure switch checks for proper combustion air inducer operation before allowing an ignition trial. The switch is factory-set. No field adjustment is necessary.

#### H-Flame Roll out Switch (S47)

This normally closed switch opens on a temperature rise. The roll out switch is factory-set and is not field adjustable. See FIGURE 38.

#### I-Evaporator Coil

Inspect and clean coil at beginning of each cooling season. Clean using mild detergent or commercial coil cleaner. Flush coil and condensate drain with water taking care not to get insulation, filters and return air ducts wet.

### J-Condenser Coil

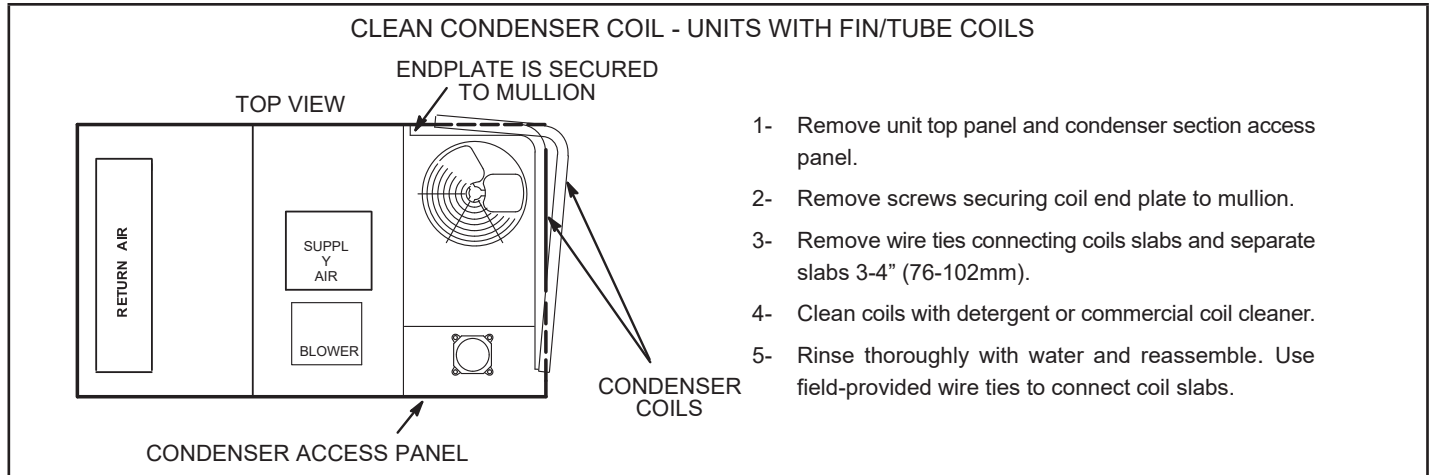
Clean condenser coil annually with detergent or commercial coil cleaner and inspect monthly during the cooling season.

Condenser coils are made of single and two formed slabs. On units with two slabs, dirt and debris may become trapped between the slabs. To clean between slabs, carefully separate coil slabs and wash them thoroughly. See FIGURE 38. Flush coils with water following cleaning.

**NOTE** - Remove all screws and gaskets prior to cleaning procedure and replace upon completion.

### K-Supply Air Blower Wheel

Annually inspect supply air blower wheel for accumulated dirt or dust. Turn off power before attempting to remove access panel or to clean blower wheel.



**FIGURE 39**

### L-Needlepoint Bipolar Ionizer (Optional)

The optional, brush-type ionizer produces positive and negative ions to clean air and reduce airborne contaminants. The ionizer was designed to be low maintenance. The device should be checked semi-annually to confirm the brushes are clean for maximum output. The ionizer is located behind on the blower deck to the left of the blower. See FIGURE 41.

- 1 - On the back side of the unit, remove the screw securing the back of the ionizer bracket. See FIGURE 40. Retain the screw to secure the back side of the ionizer bracket.
- 2 - Remove two screws securing the front side of the ionizer bracket and pull out of unit and clean brushes.
- 3 - Replace ionizer in the reverse order it was removed.

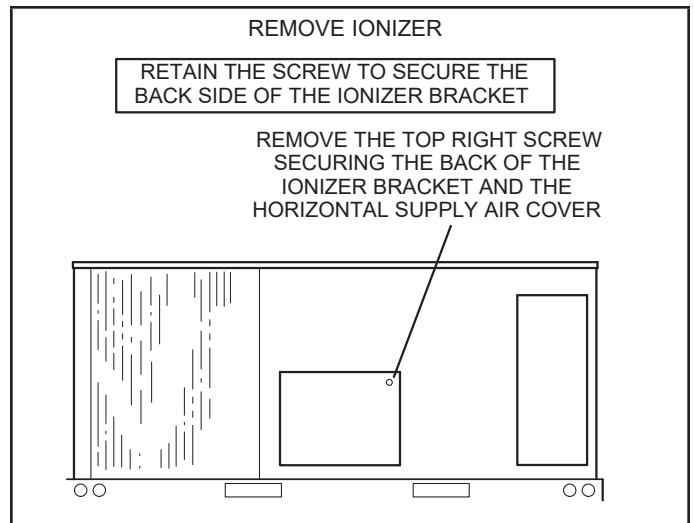


FIGURE 40

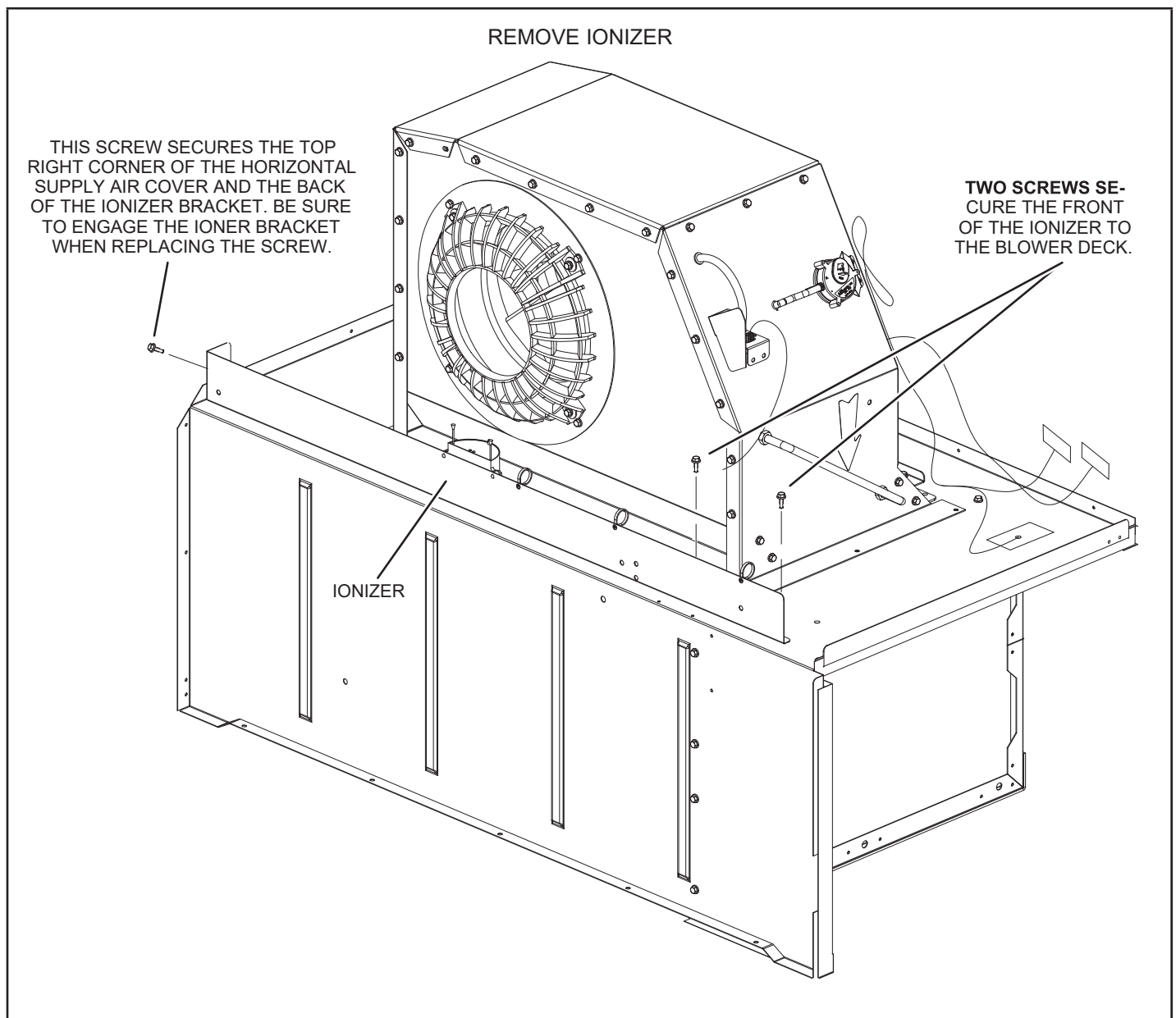


FIGURE 41

## M-UVC Light (Optional)

When field-installed, use only UVC Light Kit assembly 106881-01 (21A92) with this appliance.

### Factory-Installed UVC Light

When the UVC light is factory installed, the lamp is shipped attached to the filter rack. Remove the lamp and install into the UVC light assembly as shown in steps 2 through 11.

- 1 - Cut wire ties and remove the UVC lamp attached to the filter rack. See FIGURE 42.

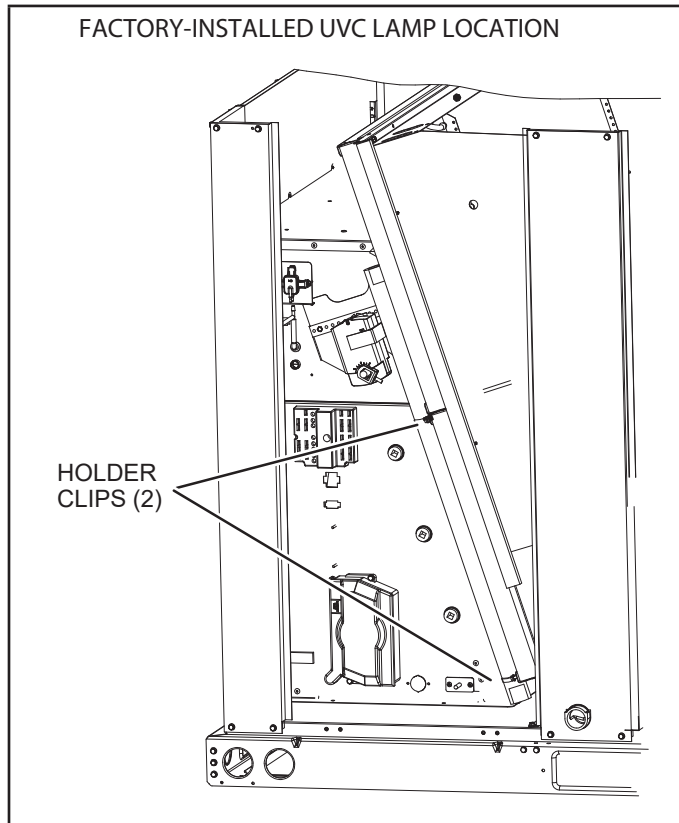


FIGURE 42

### Annual Lamp Replacement

## ⚠ WARNING

### Personal Burn Hazard.

Personal injury may result from hot lamps. During replacement, allow lamp to cool for 10 minutes before removing lamp from fixture.

The lamp should be replaced every 12 months, as UVC energy production diminishes over time.

- 1 - Obtain replacement lamp 102337-01 for your germicidal light model.
- 2 - Disconnect power to the rooftop unit before servicing the UVC kit.
- 3 - Open the blower access door.
- 4 - Remove the screw in wire tie from the UVC assembly and disconnect the 4-pin connector from the lamp end.

- 5 - Remove the (2) mounting screws of the UVC assembly. Carefully slide the complete UVC assembly out through the blower access door.
- 6 - Allow 10 minutes before touching the lamps. Then, carefully remove the old lamp from the lamp holder clips.
- 7 - Wear cotton gloves or use a cotton cloth when handling the new lamp. Place the new lamp in the holder clips of the UVC assembly. Verify that the lamp flange at the connector end is sandwiched between the lamp holder clip and the sheet-metal end stop (see FIGURE 43).
- 8 - Carefully place the UVC assembly on the blower deck. Line up the mounting holes on the UVC assembly with the mounting holes on the blower deck. See FIGURE 44. Use the #10 screws provided to attach the UVC assembly in place.
- 9 - Make sure to reapply the black convoluted tubing used to shield electrical wiring in the rooftop unit. Convoluted tubing is provided when the ionizer is factory- or field-installed. However, if there is any concern, aluminum foil tape (not provided) can also be used to cover any exposed component.
- 10 - Close the blower access door.
- 11 - Reconnect power to the rooftop unit.
- 12 - Open the filter access door and look through the view port in the triangular sheet-metal panel to verify that the UVC light is on.

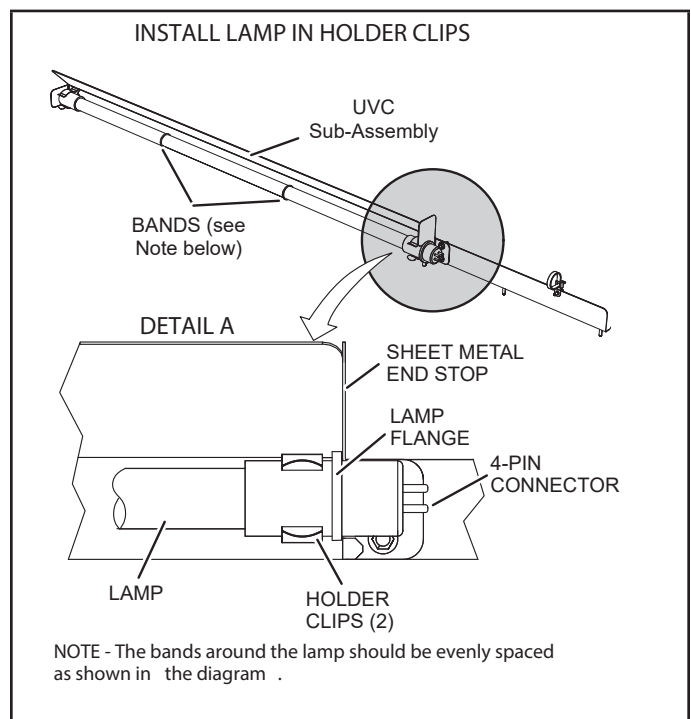
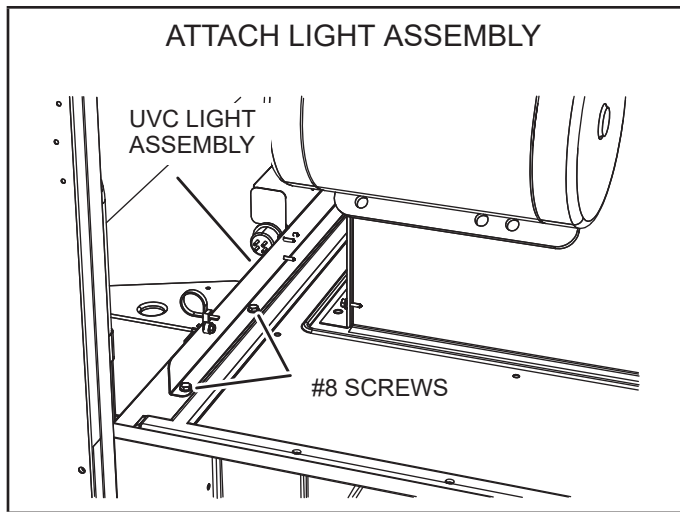


FIGURE 43



**FIGURE 44**

**Lamp Disposal**

Hg-LAMP Contains Mercury. Manage in accordance with local, state and federal disposal laws. Refer to [www.lamprecycle.org](http://www.lamprecycle.org) or call 1-800-453-6669.

**Proper Clean-up Technique in Case of Lamp Breakage**

Wear protective gloves, eye wear and mask.

Sweep the broken glass and debris into a plastic bag, seal the bag, and dispose of properly. Contact your local waste management office for proper disposal.

Do not use a vacuum cleaner. Do not incinerate.

**Maintenance**

- For all maintenance, contact a qualified HVAC technician.
- Read the maintenance instructions before opening unit panels.
- Unintended use of the unit or damage to the unit housing may result in the escape of dangerous UVC radiation. UVC radiation may, even in small doses, cause harm to the eyes and skin.
- Do not operate units that are obviously damaged.
- Do not discard the triangular UVC light shield or any barriers with an ultraviolet radiation symbol.
- Do not override the door interlock switch that interrupts power to the UVC light.
- Do not operate the UVC light outside of the unit.

**N-Replacement Fuses**

See the following tables for the proper replacement fuse sizes.

| ELECTRIC HEAT REPLACEMENT FUSES |                 |      |        |      |
|---------------------------------|-----------------|------|--------|------|
|                                 | Electric Heat   | Qty. | Rating |      |
|                                 |                 |      | Amp    | Volt |
| 1                               | E1EH0050N-1P    | 2    | 30     | 250  |
| 2                               | T1/E1EH0075AN1Y | 3    | 25     | 250  |
| 3                               | E1EH0100N-1P    | 4    | 30     | 250  |
| 4                               | T1/E1EH0150AN1Y | 3    | 50     | 250  |
| 5                               | T1/E1EH0225AN1Y | 6    | 45     | 250  |
| 6                               | T1/E1EH0300N-1Y | 6    | 60     | 250  |
| 7                               | E2EH0300N-1Y    | 6    | 60     | 250  |
| 8                               | K1EH0050A-1P    | 2    | 30     | 250  |
| 9                               | T1/E1EH0075AN1P | 2    | 40     | 250  |
| 10                              | T1EH0100A-1P    | 4    | 30     | 250  |
| 11                              | T1/E1EH0150AN1P | 4    | 40     | 250  |
| 12                              | T1/E1EH0225AN1P | 6    | 40     | 250  |
| 13                              | T1/E1EH0075AN1J | 3    | 15     | 600  |
| 14                              | T1/E1EH0150AN1J | 3    | 20     | 600  |
| 15                              | T1/E1EH0225AN1J | 3    | 30     | 600  |
| 16                              | T1/E1EH0300N-1J | 3    | 40     | 600  |
| 17                              | T1/E1EH0075AN1G | 3    | 15     | 600  |
| 18                              | T1/E1EH0150AN1G | 3    | 25     | 600  |
| 19                              | T1/E1EH0225AN1G | 3    | 35     | 600  |
| 20                              | T1/E1EH0300N-1G | 3    | 50     | 600  |
| 21                              | K1/E1EH0057AN1M | 3    | 15     | 600  |
| 22                              | K1/E1EH0115AN1M | 3    | 20     | 600  |
| 23                              | K1EH0172AN1M    | 3    | 30     | 600  |
| 24                              | E1EH0172N-1M    | 3    | 30     | 600  |
| 25                              | K1/E1EH0230N-1M | 3    | 40     | 600  |

| UNIT REPLACEMENT FUSES |       |             |                 |            |            |            |            |            |
|------------------------|-------|-------------|-----------------|------------|------------|------------|------------|------------|
| LGM036                 |       |             |                 |            |            |            |            |            |
| Unit Voltage           |       |             | 208/230V - 3 Ph |            | 460V - 3Ph |            | 575V - 3Ph |            |
| Power Exhaust Option   |       |             | W / P.E.        | W / O P.E. | W / P.E.   | W / O P.E. | W / P.E.   | W / O P.E. |
| Diagram Key            | Class | Blower Type | Amps            |            |            |            |            |            |
| F10 <sup>2</sup>       | CC    | EBM         | 8 A             | 8 A        | 8 A        | 8 A        | 8 A        | 8 A        |
| F27                    | CC    | EBM         | -               | -          | -          | -          | 7.5 A      | 7.5 A      |
| F57                    | CC    | EBM         | -               | -          | 10 A       | 10 A       | 7.5 A      | 7.5 A      |
| F61 <sup>2</sup>       | J     | EBM         | 30 A            | 25 A       | 15 A       | 15 A       | 15 A       | 15 A       |
| CB10 <sup>3</sup>      | -     | EBM         | 30 A            | 25 A       | 15 A       | 15 A       | 15 A       | 15 A       |

<sup>2</sup> Fuses F10 and F61 are only used on units with SCCR installed.

<sup>3</sup> Units using Circuit Breakers will use CB10 option.

| LGM048               |       |             |                 |            |            |            |            |            |
|----------------------|-------|-------------|-----------------|------------|------------|------------|------------|------------|
| Unit Voltage         |       |             | 208/230V - 3 Ph |            | 460V - 3Ph |            | 575V - 3Ph |            |
| Power Exhaust Option |       |             | W / P.E.        | W / O P.E. | W / P.E.   | W / O P.E. | W / P.E.   | W / O P.E. |
| Diagram Key          | Class | Blower Type | Amps            |            |            |            |            |            |
| F10 <sup>2</sup>     | CC    | EBM         | 8 A             | 8 A        | 8 A        | 8 A        | 8 A        | 8 A        |
| F27                  | CC    | EBM         | -               | -          | -          | -          | 7.5 A      | 7.5 A      |
| F57                  | CC    | EBM         | -               | -          | 10 A       | 10 A       | 7.5 A      | 7.5 A      |
| F61 <sup>2</sup>     | J     | EBM         | 40 A            | 30 A       | 15 A       | 15 A       | 15 A       | 15 A       |
| CB10 <sup>3</sup>    | -     | EBM         | 40 A            | 30 A       | 15 A       | 15 A       | 15 A       | 15 A       |

<sup>2</sup> Fuses F10 and F61 are only used on units with SCCR installed.

<sup>3</sup> Units using Circuit Breakers will use CB10 option.

| LGM060               |       |           |                 |            |            |            |            |            |
|----------------------|-------|-----------|-----------------|------------|------------|------------|------------|------------|
| Unit Voltage         |       |           | 208/230V - 3 Ph |            | 460V - 3Ph |            | 575V - 3Ph |            |
| Power Exhaust Option |       |           | W / P.E.        | W / O P.E. | W / P.E.   | W / O P.E. | W / P.E.   | W / O P.E. |
| Diagram Key          | Class | Blower HP | Amps            |            |            |            |            |            |
| F10 <sup>2</sup>     | CC    | EBM       | 8 A             | 8 A        | 8 A        | 8 A        | 8 A        | 8 A        |
| F27                  | CC    | EBM       | -               | -          | -          | -          | 7.5 A      | 7.5 A      |
| F57                  | CC    | EBM       | -               | -          | 10 A       | 10 A       | 7.5 A      | 7.5 A      |
| F61 <sup>2</sup>     | J     | EBM       | 40 A            | 40 A       | 20 A       | 15 A       | 15 A       | 15 A       |
| CB10 <sup>3</sup>    | -     | EBM       | 40 A            | 40 A       | 20 A       | 15 A       | 15 A       | 15 A       |

<sup>2</sup> Fuses F10 and F61 are only used on units with SCCR installed.

<sup>3</sup> Units using Circuit Breakers will use CB10 option.

| LGM074               |       |           |                 |            |            |            |            |            |
|----------------------|-------|-----------|-----------------|------------|------------|------------|------------|------------|
| Unit Voltage         |       |           | 208/230V - 3 Ph |            | 460V - 3Ph |            | 575V - 3Ph |            |
| Power Exhaust Option |       |           | W / P.E.        | W / O P.E. | W / P.E.   | W / O P.E. | W / P.E.   | W / O P.E. |
| Diagram Key          | Class | Blower HP | Amps            |            |            |            |            |            |
| F10 <sup>2</sup>     | CC    | EBM       | 8 A             | 8 A        | 8 A        | 8 A        | 8 A        | 8 A        |
| F27                  | CC    | EBM       | -               | -          | -          | -          | 7.5 A      | 7.5 A      |
| F57                  | CC    | EBM       | -               | -          | 10 A       | 10 A       | 7.5 A      | 7.5 A      |
| F61 <sup>2</sup>     | J     | EBM       | 45 A            | 45 A       | 20 A       | 20 A       | 15 A       | 15 A       |
| CB10 <sup>3</sup>    | J     | EBM       | 45 A            | 45 A       | 20 A       | 20 A       | 15 A       | 15 A       |

<sup>2</sup> Fuses F10 and F61 are only used on units with SCCR installed.

<sup>3</sup> Units using Circuit Breakers will use CB10 option.

| LCM036               |                      |           |                 |            |             |            |             |            |                 |            |             |            |             |            |
|----------------------|----------------------|-----------|-----------------|------------|-------------|------------|-------------|------------|-----------------|------------|-------------|------------|-------------|------------|
| Electric Heat Size   |                      |           | 7.5kW           |            |             |            |             |            | 15kW            |            |             |            |             |            |
| Unit Voltage         |                      |           | 208/230V - 3 Ph |            | 460V - 3 Ph |            | 575V - 3 Ph |            | 208/230V - 3 Ph |            | 460V - 3 Ph |            | 575V - 3 Ph |            |
| Power Exhaust Option |                      |           | W / P.E.        | W / O P.E. | W / P.E.    | W / O P.E. | W / P.E.    | W / O P.E. | W / P.E.        | W / O P.E. | W / P.E.    | W / O P.E. | W / P.E.    | W / O P.E. |
| Diagram Key          | Class                | Blower HP | Amps            |            |             |            |             |            | Amps            |            |             |            |             |            |
| F4                   | RK or K <sup>1</sup> | 1.5       | 30 A            | 25 A       | 15 A        | 15 A       | 15 A        | 15 A       | 30 A            | 25 A       | 15 A        | 15 A       | 15 A        | 15 A       |
| F10 <sup>2</sup>     | CC                   | 1.5       | 8 A             | 8 A        | 8 A         | 8 A        | 8 A         | 8 A        | 8 A             | 8 A        | 8 A         | 8 A        | 8 A         | 8 A        |
| F27                  | CC                   | 1.5       | -               | -          | -           | -          | 7.5 A       | 7.5 A      | -               | -          | -           | -          | 7.5 A       | 7.5 A      |
| F57                  | CC                   | 1.5       | -               | -          | 10 A        | 10 A       | 7.5 A       | 7.5 A      | -               | -          | 10 A        | 10 A       | 7.5 A       | 7.5 A      |
| F61 <sup>2</sup>     | J                    | 1.5       | 35 A            | 30 A       | 20 A        | 15 A       | 15 A        | 15 A       | 60 A            | 60 A       | 30 A        | 30 A       | 25 A        | 25 A       |
| CB10 <sup>3</sup>    | -                    | 1.5       | 35 A            | 30 A       | 20 A        | 15 A       | 15 A        | 15 A       | 60 A            | 60 A       | 30 A        | 30 A       | 25 A        | 25 A       |

<sup>1</sup> When SCCR is installed, F4 fuse is Class J.

<sup>2</sup> Fuses F10 and F61 are only used on units with SCCR installed.

<sup>3</sup> Units using Circuit Breakers will use CB10 option.

| LCM048               |                      |           |                 |            |             |            |             |            |                 |            |             |            |             |            |
|----------------------|----------------------|-----------|-----------------|------------|-------------|------------|-------------|------------|-----------------|------------|-------------|------------|-------------|------------|
| Electric Heat Size   |                      |           | 7.5kW           |            |             |            |             |            | 15kW            |            |             |            |             |            |
| Unit Voltage         |                      |           | 208/230V - 3 Ph |            | 460V - 3 Ph |            | 575V - 3 Ph |            | 208/230V - 3 Ph |            | 460V - 3 Ph |            | 575V - 3 Ph |            |
| Power Exhaust Option |                      |           | W / P.E.        | W / O P.E. | W / P.E.    | W / O P.E. | W / P.E.    | W / O P.E. | W / P.E.        | W / O P.E. | W / P.E.    | W / O P.E. | W / P.E.    | W / O P.E. |
| Diagram Key          | Class                | Blower HP | Amps            |            |             |            |             |            | Amps            |            |             |            |             |            |
| F4                   | RK or K <sup>1</sup> | 1.5       | 40 A            | 35 A       | 15 A        | 15 A       | 15 A        | 15 A       | 40 A            | 35 A       | 15 A        | 15 A       | 15 A        | 15 A       |
| F10 <sup>2</sup>     | CC                   | 1.5       | 8 A             | 8 A        | 8 A         | 8 A        | 8 A         | 8 A        | 8 A             | 8 A        | 8 A         | 8 A        | 8 A         | 8 A        |
| F27                  | CC                   | 1.5       | -               | -          | -           | -          | 7.5 A       | 7.5 A      | -               | -          | -           | -          | 7.5 A       | 7.5 A      |
| F57                  | CC                   | 1.5       | -               | -          | 10 A        | 10 A       | 7.5 A       | 7.5 A      | -               | -          | 10 A        | 10 A       | 7.5 A       | 7.5 A      |
| F61 <sup>2</sup>     | J                    | 1.5       | 40 A            | 35 A       | 20 A        | 15 A       | 15 A        | 15 A       | 60 A            | 60 A       | 30 A        | 30 A       | 25 A        | 25 A       |
| CB10 <sup>3</sup>    | -                    | 1.5       | 40 A            | 35 A       | 20 A        | 15 A       | 15 A        | 15 A       | 60 A            | 60 A       | 30 A        | 30 A       | 25 A        | 25 A       |

<sup>1</sup> When SCCR is installed, F4 fuse is Class J.

<sup>2</sup> Fuses F10 and F61 are only used on units with SCCR installed.

<sup>3</sup> Units using Circuit Breakers will use CB10 option.

| LCM060               |                      |           |                 |            |             |            |             |            |                 |            |             |            |             |            |
|----------------------|----------------------|-----------|-----------------|------------|-------------|------------|-------------|------------|-----------------|------------|-------------|------------|-------------|------------|
| Electric Heat Size   |                      |           | 7.5kW           |            |             |            |             |            | 15kW            |            |             |            |             |            |
| Unit Voltage         |                      |           | 208/230V - 3 Ph |            | 460V - 3 Ph |            | 575V - 3 Ph |            | 208/230V - 3 Ph |            | 460V - 3 Ph |            | 575V - 3 Ph |            |
| Power Exhaust Option |                      |           | W / P.E.        | W / O P.E. | W / P.E.    | W / O P.E. | W / P.E.    | W / O P.E. | W / P.E.        | W / O P.E. | W / P.E.    | W / O P.E. | W / P.E.    | W / O P.E. |
| Diagram Key          | Class                | Blower HP | Amps            |            |             |            |             |            | Amps            |            |             |            |             |            |
| F4                   | RK or K <sup>1</sup> | 1.5       | 40 A            | 40 A       | 20 A        | 15 A       | 15 A        | 15 A       | 40 A            | 40 A       | 20 A        | 15 A       | 15 A        | 15 A       |
| F10 <sup>2</sup>     | CC                   | 1.5       | 8 A             | 8 A        | 8 A         | 8 A        | 8 A         | 8 A        | 8 A             | 8 A        | 8 A         | 8 A        | 8 A         | 8 A        |
| F27                  | CC                   | 1.5       | -               | -          | -           | -          | 7.5 A       | 7.5 A      | -               | -          | -           | -          | 7.5 A       | 7.5 A      |
| F57                  | CC                   | 1.5       | -               | -          | 10 A        | 10 A       | 7.5 A       | 7.5 A      | -               | -          | 10 A        | 10 A       | 7.5 A       | 7.5 A      |
| F61 <sup>2</sup>     | J                    | 1.5       | 40 A            | 40 A       | 20 A        | 15 A       | 15 A        | 15 A       | 60 A            | 60 A       | 30 A        | 30 A       | 25 A        | 25 A       |
| CB10 <sup>3</sup>    | -                    | 1.5       | 40 A            | 40 A       | 20 A        | 15 A       | 15 A        | 15 A       | 60 A            | 60 A       | 30 A        | 30 A       | 25 A        | 25 A       |

<sup>1</sup> When SCCR is installed, F4 fuse is Class J.

<sup>2</sup> Fuses F10 and F61 are only used on units with SCCR installed.

<sup>3</sup> Units using Circuit Breakers will use CB10 option.

| LCM060 (continued)   |                      |           |                 |            |             |            |             |            |
|----------------------|----------------------|-----------|-----------------|------------|-------------|------------|-------------|------------|
| Electric Heat Size   |                      |           | 22.5kW          |            |             |            |             |            |
| Unit Voltage         |                      |           | 208/230V - 3 Ph |            | 460V - 3 Ph |            | 575V - 3 Ph |            |
| Power Exhaust Option |                      |           | W / P.E.        | W / O P.E. | W / P.E.    | W / O P.E. | W / P.E.    | W / O P.E. |
| Diagram Key          | Class                | Blower HP | Amps            |            |             |            |             |            |
| F4                   | RK or K <sup>1</sup> | 1.5       | 40 A            | 40 A       | 20 A        | 15 A       | 15 A        | 15 A       |
| F10 <sup>2</sup>     | CC                   | 1.5       | 8 A             | 8 A        | 8 A         | 8 A        | 8 A         | 8 A        |
| F27                  | CC                   | 1.5       | -               | -          | -           | -          | 7.5 A       | 7.5 A      |
| F57                  | CC                   | 1.5       | -               | -          | 10 A        | 10 A       | 7.5 A       | 7.5 A      |
| F61 <sup>2</sup>     | J                    | 1.5       | 80 A            | 80 A       | 40 A        | 40 A       | 35 A        | 35 A       |
| CB10 <sup>3</sup>    | -                    | 1.5       | 80 A            | 80 A       | 40 A        | 40 A       | 35 A        | 35 A       |

<sup>1</sup> When SCCR is installed, F4 fuse is Class J.

<sup>2</sup> Fuses F10 and F61 are only used on units with SCCR installed.

<sup>3</sup> Units using Circuit Breakers will use CB10 option.

| LCM074               |                      |             |                 |            |            |            |            |            |                 |            |            |            |            |            |
|----------------------|----------------------|-------------|-----------------|------------|------------|------------|------------|------------|-----------------|------------|------------|------------|------------|------------|
| Electric Heat Size   |                      |             | 7.5 KW          |            |            |            |            |            | 15 KW           |            |            |            |            |            |
| Unit Voltage         |                      |             | 208/230V - 3 Ph |            | 460V - 3Ph |            | 575V - 3Ph |            | 208/230V - 3 Ph |            | 460V - 3Ph |            | 575V - 3Ph |            |
| Power Exhaust Option |                      |             | W / P.E.        | W / O P.E. | W / P.E.   | W / O P.E. | W / P.E.   | W / O P.E. | W / P.E.        | W / O P.E. | W / P.E.   | W / O P.E. | W / P.E.   | W / O P.E. |
| Diagram Key          | Class                | Blower Type | Amps            |            |            |            |            |            | Amps            |            |            |            |            |            |
| F4                   | RK or K <sup>1</sup> | EBM         | 45 A            | 45 A       | 20 A       | 20 A       | 15 A       | 15 A       | 45 A            | 45 A       | 20 A       | 20 A       | 15 A       | 15 A       |
| F10 <sup>2</sup>     | CC                   | EBM         | 8 A             | 8 A        | 8 A        | 8 A        | 8 A        | 8 A        | 8 A             | 8 A        | 8 A        | 8 A        | 8 A        | 8 A        |
| F27                  | CC                   | EBM         | -               | -          | -          | -          | 7.5 A      | 7.5 A      | -               | -          | -          | -          | 7.5 A      | 7.5 A      |
| F57                  | CC                   | EBM         | -               | -          | 10 A       | 10 A       | 7.5 A      | 7.5 A      | -               | -          | 10 A       | 10 A       | 7.5 A      | 7.5 A      |
| F61 <sup>2</sup>     | J                    | EBM         | 45 A            | 45 A       | 20 A       | 20 A       | 15 A       | 15 A       | 60 A            | 60 A       | 30 A       | 30 A       | 25 A       | 25 A       |
| CB10 <sup>3</sup>    | -                    | EBM         | 45 A            | 45 A       | 20 A       | 20 A       | 15 A       | 15 A       | 60 A            | 60 A       | 30 A       | 30 A       | 25 A       | 25 A       |

<sup>1</sup> When SCCR is installed, F4 fuse is Class J.

<sup>2</sup> Fuses F10 and F61 are only used on units with SCCR installed.

<sup>3</sup> Units using Circuit Breakers will use CB10 option.

| LCM074 (continued)   |                      |             |          |            |          |            |          |            |                 |            |            |            |             |            |
|----------------------|----------------------|-------------|----------|------------|----------|------------|----------|------------|-----------------|------------|------------|------------|-------------|------------|
| Electric Heat Size   |                      |             | 22.5 KW  |            |          |            |          |            | 30 KW           |            |            |            |             |            |
| Unit Voltage         |                      |             | Y Volt   |            | G Volt   |            | J Volt   |            | 208/230V - 3 Ph |            | 460V - 3Ph |            | 575V - 3 Ph |            |
| Power Exhaust Option |                      |             | W / P.E. | W / O P.E. | W / P.E. | W / O P.E. | W / P.E. | W / O P.E. | W / P.E.        | W / O P.E. | W / P.E.   | W / O P.E. | W / P.E.    | W / O P.E. |
| Diagram Key          | Class                | Blower Type | Amps     |            |          |            |          |            |                 |            |            |            |             |            |
| F4                   | RK or K <sup>1</sup> | EBM         | 45 A     | 45 A       | 20 A     | 20 A       | 15 A     | 15 A       | 45 A            | 45 A       | 20 A       | 20 A       | 15 A        | 15 A       |
| F10 <sup>2</sup>     | CC                   | EBM         | 8 A      | 8 A        | 8 A      | 8 A        | 8 A      | 8 A        | 8 A             | 8 A        | 8 A        | 8 A        | 8 A         | 8 A        |
| F27                  | CC                   | EBM         | -        | -          | -        | -          | 7.5 A    | 7.5 A      | -               | -          | -          | -          | 7.5 A       | 7.5 A      |
| F57                  | CC                   | EBM         | -        | -          | 10 A     | 10 A       | 7.5 A    | 7.5 A      | -               | -          | 10 A       | 10 A       | 7.5 A       | 7.5 A      |
| F61 <sup>2</sup>     | J                    | EBM         | 80 A     | 80 A       | 40 A     | 40 A       | 35 A     | 30 A       | 100 A           | 100 A      | 50 A       | 50 A       | 45 A        | 40 A       |
| CB10 <sup>3</sup>    | -                    | EBM         | 80 A     | 80 A       | 40 A     | 40 A       | 35 A     | 30 A       | 100 A           | 100 A      | 50 A       | 50 A       | 45 A        | 40 A       |

<sup>1</sup> When SCCR is installed, F4 fuse is Class J.

<sup>2</sup> Fuses F10 and F61 are only used on units with SCCR installed.

<sup>3</sup> Units using Circuit Breakers will use CB10 option.

## Factory Unit Controller Settings

Use the mobile service app to adjust parameters; menu paths are shown in each table. Refer to the Unit Controller manual provided with each unit.

TABLE 18 through TABLE 20 show factory settings (in degrees, % of fan CFM, etc.). Record adjusted settings on the label located inside the compressor access panel.

When field installing optional kits and accessories, the Unit Controller must be configured to identify the option before it will function. Refer to FIGURE 45 and FIGURE 46 to determine whether the Unit Controller configuration I.D. must change. To configure the option, use MAIN MENU > SETUP > INSTALL menu path. Press SAVE until CONFIGURATION ID 1 or 2 appears depending on the option installed. Change the appropriate character in the configuration I.D. For example, when an economizer is installed using a single enthalpy sensor, change configuration I.D. 1, the second character, to "S".

**TABLE 18**

| Units With BACnet Settings  |  |
|---|--|
| RTU Menu > Network Integration > Network Setup Wizard > BACnet MS/TP > See BACnet MAC Address |  |
| BACNET MAC ADDRESS:   |  |
| Units With Room Sensor, CPC/LSE Gateway Settings  |  |
| RTU Menu > Network Integration > Network Setup Wizard > SBUS > Set SBUS Address               |  |
| LCONN ADDRESS:  |  |

**TABLE 19**

| Units With Hot Gas Reheat                        |                 |               |   |
|--|-----------------|---------------|---|
| RTU Menu > Settings "RTU Options" > Dehumidifier |                 |               |   |
| Parameter  | Factory Setting | Field Setting | Description   |
| 105  | 7               |               | Factory Setting 7: Reheat mode enabled without prerequisite conditions. Controlled by RH sensor (A91) connected to input A55_P298_5 and set point set at parameter 106 (default 60%). |

**TABLE 20**

| Units With LonTalk Settings  |  |
|--|--|
| Use menu RTU Menu > Network Integration > Network Setup Wizard > Set "LONTALK" |  |

**IMPORTANT:** Always refer to the white sticker titled ORIGINAL FACTORY UNIT CONFIGURATION located inside the control box area.

## CONFIGURATION ID 1

1 2 3 4 5 6 7 8

### Humiditrol [1]

Not Installed = **N**

Humiditrol Installed = **H**

Unconfigured = **U**

### Economizer [2]

Not Installed = **N**

Motorized Outdoor Air  
Damper Only = **M**

Economizer - Temperature = **T**

Economizer Global = **G**

Economizer - Single  
Enthalpy = **S**

Economizer - Dual Enthalpy = **D**

Unconfigured = **U**

### Power Exhaust [3]

Not Installed = **N**

Dual-Stage = **D**

Single-Stage = **S**

Unconfigured = **U**

### Power Exhaust Control [4]

Not Installed = **N**

Damper Position = **A**

A34 Pressure Sensor = **C**

### [8] Outdoor Air Control

**N** = No Outdoor Air CFM Control

**L** = Outdoor Air Control Installed  
with A24 Sensor set for low range.

**M** = Outdoor Air Control Installed  
with A24 Sensor set for medium  
range.

**H** = Outdoor Air Control Installed  
with A24 Sensor set for high  
range.

### [7] System Blower Sub-type

**N** = Not Applicable

**B** = VFD Belt Drive Blower (MODBUS)

**H** = Direct-Plus® Blower (MODBUS)

**L** = ECM Direct-Drive Blower (PWM)

### [6] Blower Variable Frequency Drive Bypass

**N** = Not Installed

**A** = Automatic Electronic Bypass

**M** = Manual Electronic Bypass

**U** = Electronic Bypass Field  
Un-configured

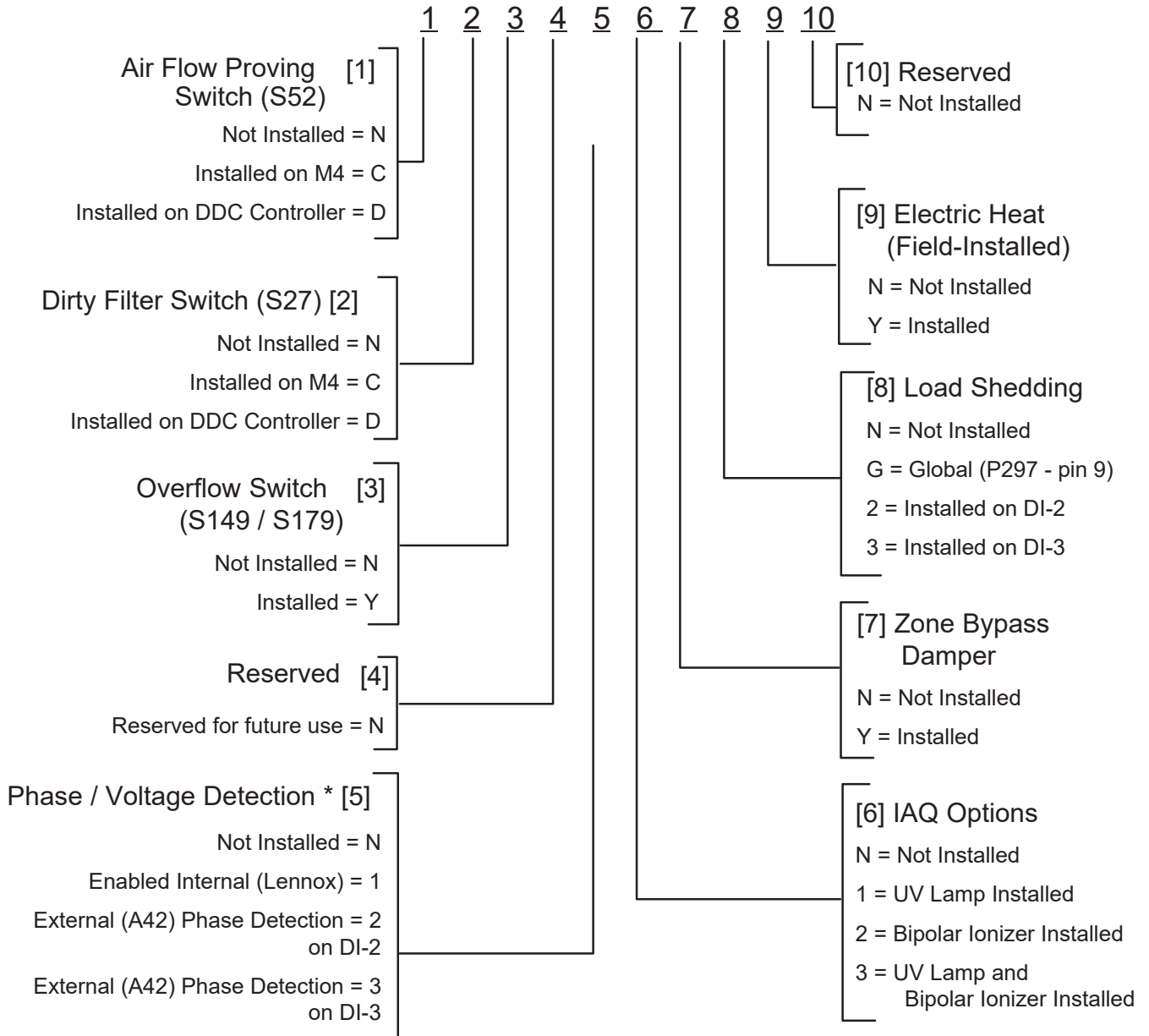
### [5] Network Module

**N** = Not Installed

**L** = LonTalk

FIGURE 45

## Configuration ID 2



\* When phase detection and voltage monitoring is enabled and wired incorrectly, the system will go into demand hold status and restart after six minutes.

**FIGURE 46**

## Decommissioning

Before carrying out this procedure, it is essential that the technician is completely familiar with the equipment and all its detail. It is recommended good practice that all refrigerants are recovered safely.

Prior to the task being carried out, an oil and refrigerant sample shall be taken in case analysis is required prior to re-use of recovered refrigerant. It is essential that electrical power is available before starting decommissioning.

- a) Become familiar with the equipment and its operation.
- b) Isolate system electrically.
- c) Before attempting the procedure, ensure that:
  - mechanical handling equipment is available, if required, for handling refrigerant cylinders;
  - all personal protective equipment is available and being used correctly;
  - the recovery process is supervised at all times by a competent person;
  - recovery equipment and cylinders conform to the appropriate standards.
- d) Pump down refrigerant system, if possible.
- e) If a vacuum is not possible, make a manifold so that refrigerant can be removed from various parts of the system.
- f) Make sure that cylinder is situated on the scales before recovery takes place.
- g) Start the recovery machine and operate in accordance with instructions.
- h) Do not overfill cylinders (no more than 80% volume liquid charge).
- i) Do not exceed the maximum working pressure of the cylinder, even temporarily.
- j) When the cylinders have been filled correctly and the process completed, make sure that the cylinders and the equipment are removed from site promptly and all isolation valves on the equipment are closed off.
- k) Recovered refrigerant shall not be charged into another REFRIGERATING SYSTEM unless it has been cleaned and checked.



## IMPORTANT

Equipment shall be labelled stating that it has been decommissioned and emptied of refrigerant. The label shall be signed and dated. Ensure that there are labels on the equipment that state the flammability of the refrigerant used.

## START-UP REPORT

Job Name: \_\_\_\_\_  
 Store No. \_\_\_\_\_ Start-Up Date: \_\_\_\_\_  
 Address: \_\_\_\_\_  
 City: \_\_\_\_\_ State: \_\_\_\_\_  
 Start-Up Contractor: \_\_\_\_\_  
 Technician: \_\_\_\_\_  
 Model No.: \_\_\_\_\_  
 Serial No.: \_\_\_\_\_  
 RTU No.: \_\_\_\_\_ Catalog No.: \_\_\_\_\_

| Inspections and Checks                                 |     |    |   |
|--|-----|----|---|
| Damage?  | Yes | No | R22 <input type="checkbox"/> R410A <input type="checkbox"/> |
| If yes, reported to: _____                             |     |    |   |
| Verify factory and field-installed accessories.        |     |    |   |
| Check electrical connections. Tighten if necessary.    |     |    |   |
| Supply voltage: L1-L2 _____ L1-L3 _____ L2-L3 _____    |     |    |   |
| If unit contains a 208-230/240 volt transformer:       |     |    |   |
| Check primary transformer tap <input type="checkbox"/> |     |    |   |
| Transformer secondary voltage: _____                   |     |    |   |

| Cooling Checks   |                 |    |    |                  |       |       |           |       |                    |    |    |                |
|--|-----------------|----|----|------------------|-------|-------|-----------|-------|--------------------|----|----|----------------|
| Compressor Rotation <input type="checkbox"/> Ambient Temp. _____ Return Air Temp. _____ Supply Air Temp. _____ |                 |    |    |                  |       |       |           |       |                    |    |    |                |
|  | Compressor Amps |    |    | Compressor Volts |       |       | Pressures |       | Condenser Fan Amps |    |    | CC Heater Amps |
|  | L1              | L2 | L3 | L1-L2            | L1-L3 | L2-L3 | Disch.    | Suct. | L1                 | L2 | L3 | L1             |
| 1  |                 |    |    |                  |       |       |           |       |                    |    |    |                |
| 2  |                 |    |    |                  |       |       |           |       |                    |    |    |                |
| 3  |                 |    |    |                  |       |       |           |       |                    |    |    |                |
| 4  |                 |    |    |                  |       |       |           |       |                    |    |    |                |
|  |                 |    |    |                  |       |       |           |       |                    |    |    |                |
|  |                 |    |    |                  |       |       |           |       |                    |    |    |                |

| Blower Checks                                  |  |              |       |
|--|--|--------------|-------|
| Pulley/Belt Alignment <input type="checkbox"/> | Blower Rotation <input type="checkbox"/> |              |       |
| Set Screws Tight <input type="checkbox"/>      | Belt Tension <input type="checkbox"/>    |              |       |
| Nameplate Amps: _____                          |  | Volts: _____ |       |
| Motor  | Amps                                     | Volts        |       |
| L1   | _____                                    | L1-L2        | _____ |
| L2   | _____                                    | L1-L3        | _____ |
| L3   | _____                                    | L2-L3        | _____ |

| Heating Checks - Gas  |                   |           |
|---|-------------------|-----------|
| Fuel type: Nat. <input type="checkbox"/> LP <input type="checkbox"/> Inlet Pressure: _____ in. w.c. |                   |           |
| Return Air Temp.: _____ Supply Air Temp.: _____   |                   |           |
| Altitude: _____ Primary Limits Operate: <input type="checkbox"/>                                    |                   |           |
| CO <sub>2</sub> %: _____  |                   |           |
| Gas Valve   | Manifold Pressure |           |
|   | Low Fire          | High Fire |
| GV1   |                   |           |
| GV2   |                   |           |

| Control Type |
|--------------|
|              |

| Heating Checks - Electric                       |      |    |    |    |    |    |    |
|---|------|----|----|----|----|----|----|
| Return Air Temp.: _____ Supply Air Temp.: _____ |      |    |    |    |    |    |    |
| Limits Operate: <input type="checkbox"/>        |      |    |    |    |    |    |    |
|   | Amps |    |    |    |    |    |    |
|   | L1   | L2 | L3 |    | L1 | L2 | L3 |
| 1   |      |    |    | 10 |    |    |    |
| 2   |      |    |    | 11 |    |    |    |
| 3   |      |    |    | 12 |    |    |    |
| 4   |      |    |    | 13 |    |    |    |
| 5   |      |    |    | 14 |    |    |    |
| 6   |      |    |    | 15 |    |    |    |
| 7   |      |    |    | 16 |    |    |    |
| 8   |      |    |    | 17 |    |    |    |
| 9   |      |    |    | 18 |    |    |    |

| Accessory Checks                   |   |
|------------------------------------|---|
| Power Exhaust Amps                 |   |
| 1 _____                            | 2 _____ None <input type="checkbox"/>                 |
| Economizer Operation               |   |
| Min. Pos. <input type="checkbox"/> | Motor travel full open/close <input type="checkbox"/> |