



©2026 Lennox Industries Inc.  
Dallas, Texas, USA

# INSTALLATION AND SETUP GUIDE

## Low Global Warming Potential (GWP) Refrigerant Detection System (RDS) Communicating Control Board (RDS Field Kit - Communicating)

**This manual must be left with the  
owner for future reference.**

**NOTE:** *Twining of furnaces is not  
permitted with the Refrigerant  
Detection System Kit!*

CONTROLS

508466-01

04/2026

Supersedes 05/2025

### Contents

Certifications.....	3	<i>Sensor Not Connected</i> .....	13
Shipping and Packing List.....	3	<i>Fault</i> .....	13
Overview.....	3	Diagnostic Codes.....	13
Operating Environment Specifications.....	3	<i>Red LED Diagnostic Codes</i> .....	14
Product Features.....	4	Test Button Functionality.....	15
Introduction.....	5	<i>Test Button - Additional Functions</i> .....	15
Dimensions.....	6	Thermostat Compatibility.....	16
Installation.....	7	<i>Compatibility Verification</i> .....	16
<i>Sensor Part Number Verification</i> .....	7	Additional Applications.....	17
<i>Mounting Methods</i> .....	7	<i>Zone HVAC System</i> .....	17
<i>Mounting Location</i> .....	7	<i>External Alarm</i> .....	17
<i>Routing the Sensor Cable</i> .....	9	Start Up Test Procedure.....	17
<i>Connecting the RDS Sensor</i> .....	10	<i>Cooling Demand</i> .....	17
Secondary Sensor.....	11	<i>Heating Demand</i> .....	18
<i>Additional Line Set Joints</i> .....	11	Wiring Diagrams.....	19
<i>Multiple Systems Installed in Same Space</i> .....	11	Diagnostic Codes and Troubleshooting.....	25
DIP Switch Settings.....	12		
Modes of Operation.....	12		
<i>Initializing</i> .....	12		
<i>Normal</i> .....	12		
<i>Refrigerant Detected</i> .....	13		



04/26  
508466-01

### **⚠WARNING**

Improper installation, adjustment, alteration, service or maintenance can cause property damage, personal injury or loss of life.

Installation and service must be performed by a licensed professional HVAC installer (or equivalent) or a service agency.

### **⚠WARNING**

All systems charged with at least 4 lbs of R-454B refrigerant are required to have a refrigerant leak detection system installed to prevent the build up of R-454B refrigerant in enclosed spaces of the HVAC equipment. A refrigerant detection system may be required for systems that have less than 4 lbs of R-454B refrigerant. For more information on this, contact Lennox Technical Support.

Installing a residential HVAC system that uses R-454B refrigerant without a refrigerant detection system may lead to a fire hazard within the home in the event of a refrigerant leak.

### **⚠WARNING**

The Lennox® RDS Blower Control Board has been tested with Lennox® coils only. Do not use a non-Lennox refrigerant detection system controller or non-Lennox leak sensor with Lennox® coils. Do not use the Lennox® RDS Blower Control Board with non-OEM coils or air handlers.

### **⚠WARNING**

Improper installation of the RDS Blower Control Board may lead to unreliable equipment operation and unreliable refrigerant detection.

In addition to installing the RDS Blower Control Board, considerations must be made regarding sensor mounting location. Please refer to respective Lennox air handler, coil, and/or sensor kit installation guides for further details.

### **⚠CAUTION**

It is the responsibility of the licensed installer or service agency to obtain the appropriate training and/or certifications to service A2L-classified HVAC systems with R-454B refrigerants.

### **⚠CAUTION**

Unit must remain powered except during service.

## Certifications

- CSA C22.2 No. 60335-2-40:22; Fourth ed.
- UL 60335-2-40; Fourth ed.

## Shipping and Packing List

Qty	Description	Cat. No.
1	Lennox® Communicating Low GWP Refrigerant Detection System Kit	27A03
2	Mounting Hardware - #6-18 1" Phillips Drive pan head with dry wall anchor	N/A

**NOTE:** *This kit is sold separately from the refrigerant detection sensor. The refrigerant sensor is included as part of a Lennox sensor kit, R-454B only coil, or R-454B only air handler.*

## Overview

Lennox® Low GWP Refrigerant Detection System, also referred to as RDS Blower Control Board, ensures safe operation of Lennox residential HVAC systems equipped with R-454B refrigerant. The RDS Blower Control Board connects to the refrigerant detection sensor, the indoor unit, the outdoor unit, and the thermostat to control the HVAC system in the event refrigerant is detected by the sensor. The RDS Blower Control Board functions with standard 24VAC or Lennox-communicating control interfaces.

## Operating Environment Specifications

The Low GWP Refrigerant Detection Kit is designed to withstand the following conditions:

Condition	Temperature Range
Normal Operation	-40°F - 185°F
Shipping/Storage	(40°C - 85°C)
Functional Range	
Humidity	10% to 90% non-condensing at 104°F (40°C)

## Product Features

- Communicating Control Board and Sensor can be used universally with any Lennox® communicating furnace or any non-communicating 24-volt furnace
- Complies with UL 60335-2-40 approved standard
- Required for all systems using R-454B refrigerant
- Connects to the RDS sensor furnished with the RDS Coil Sensor Kit
- Used as interface between indoor unit and thermostat to control system in case of refrigerant detection
- Ensures safe operation for systems equipped with R-454B refrigerant
- Prevents compressor and heating operation (if refrigerant is detected) until safe refrigeration levels are met
- Engages the blower if refrigeration is detected to mitigate any concentrations of refrigerant from the conditioned space
- Multi-color LED (light-emitting diode) for system status and as an aid in troubleshooting
- Alarm relay can trigger an external alarm if refrigerant is detected
- Zone relay opens all zone dampers (if part of a zoning system) if refrigerant is detected
- Disables power to non-communicating thermostats to prevent demand if refrigerant is detected
- Composite case with mounting hardware for drywall installation

## Introduction

The Lennox® Low GWP Refrigerant Detection System ensures safe operation of Lennox residential HVAC systems equipped with R-454B refrigerant.

The RDS activates the blower if refrigerant levels within the cabinet reach 12% of the lower flammability limit (LFL).

Power to all ignition sources within the HVAC system is automatically shut down until the RDS detects safe refrigerant levels. The RDS restores power to ignition sources after it detects refrigeration concentrations are safe. The HVAC system will then resume normal operation.

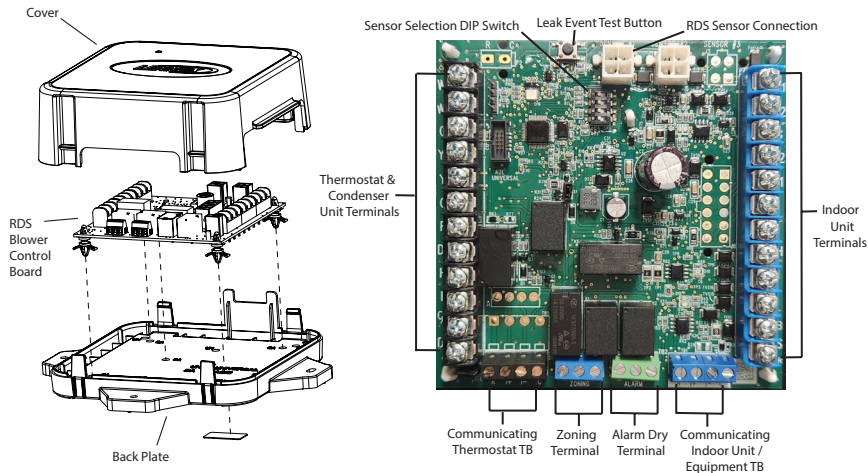

**Figure 1. RDS Communicating Control Board**

## Dimensions

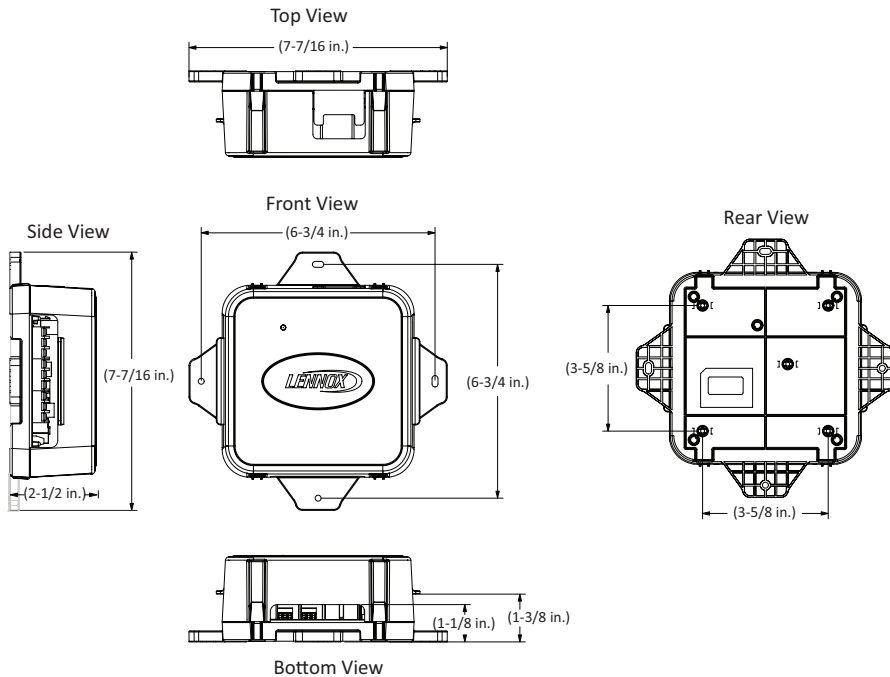

Figure 2. RDS Communicating Control Board - Dimensions

## Installation

### Sensor Part Number Verification

Verify the refrigerant detection system sensor's part number, which is found on the sensor/cable, prior to installation. The part number is 107648-01 for all units except downflow coils. The part number for the downflow coil is 067649701.

**NOTE:** *All sensors paired to a single RDS Non-Communicating Control Board **must share the same part number** (107648-01 for all units except downflow coils; 067649701 for downflow coils) to ensure the RDS Non-Communicating Control Board functions properly.*

### Mounting Methods

Some mounting surfaces may be difficult to access after the RDS Blower Control Board is installed. Lennox suggests wiring the RDS Blower Control Board unit prior to mounting in a confined space.

For drywall/closet installations, use the included drywall hardware. For attic/crawlspace/basement installations, use the included and field-provided hardware.

### Mounting Location

The RDS Blower Control Board can be mounted to the indoor unit, plenum, a stud, or joist in an attic, crawlspace, or other unfinished area within 48 inches of the refrigerant sensor cable grommet on the coil or air handler. Drywall anchors and screws are provided for installation in finished areas, such as closets. Mount the RDS Blower Control Board in a clean, dry environment that is away from dust, water, and other contaminant accumulation.

**NOTE:** *Mounting the RDS Blower Control Board farther than 48 inches away from the refrigerant sensor may prevent reliable operation due to cable strain and water seepage on cable connections.*

- **Do not** place the RDS Blower Control Board in secondary drain pan
- Use the screws provided to mount the RDS Blower Control Board
- Tighten the screws to a snug fit

**NOTE:** *Do not over-tighten the screws. Over-tightening the screws may strip the hardware and apply excessive stress on the enclosure.*

### Refrigerant Detection System Sensor

The refrigerant detection system sensor must be mounted as specified in its accompanying manual. Mounting the sensor incorrectly or in an improper location may result in refrigerant detection failure.

### Condensate Safety Switch (Float Switch)

In applications that require a condensate safety switch, a (field-provided) isolation relay must be installed with the float switch. The relay NO (normally open) contacts must be wired between “Y” and “DS” at the indoor unit control board and the (W914) jumper must be cut. See “Communicating Indoor Controls and Float Switch” on page 19.

### Refrigerant Detection System Sensors

The Lennox Refrigerant Detection System requires a Lennox RDS sensor located in the indoor coil. See table below.

Indoor Unit Model	RDS Blower Control Board Sensor Catalog Number	Description
<ul style="list-style-type: none"><li>• CK40CT Upflow</li><li>• CK40HT Horizontal</li><li>• CK40DT Downflow "Revision 01" Coils</li></ul>	26Z69	Refrigerant Detection System Coil Sensor Kit
All Lennox R-454B Air Handlers and Coils <b>except</b> CK40DT downflow coils	27V53	Coil Sensor Repair Kit (Replacement Sensor only, without mounting bracket and components provided in the Sensor Kit)
R-454B CK40DT Downflow Coils	27Z35	Coil Sensor Repair Kit (Replacement Sensor only, without mounting bracket and components provided in the Sensor Kit)

## Routing the Sensor Cable

Figure 3 illustrates how to best route the sensor cable from the RDS Blower Control Board to the sensor within the indoor unit for the Upflow, Downflow, and Horizontal orientations. For details on mounting the sensor itself, refer to the respective sensor kit, air handler, or coil installation guide.

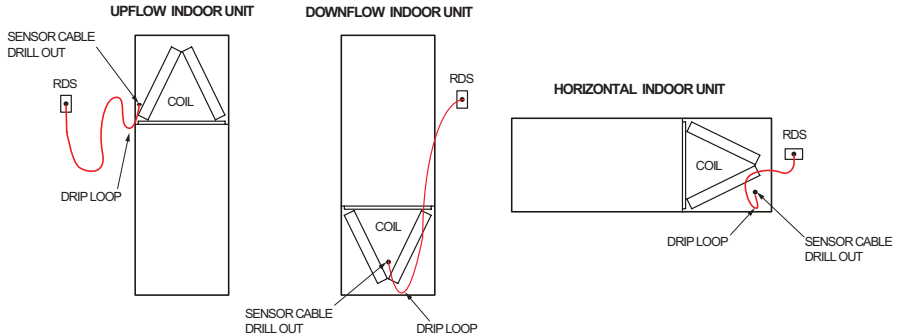

Figure 3. Routing the Sensor Cable

### **⚠WARNING**

Do not strap the RDS Blower Control Board to existing tubing or other electrical cables.

## Connecting the RDS Sensor

Ensure the cable is properly seated into the SENSOR 1 plug. The Molex plug clip should lock into the Molex connection point for a secured connection, as shown below in Figure 4. Verify the connection is free of dust, debris, and moisture.

**NOTE:** *In confined space applications, connect the second sensor to the SENSOR 2 plug.*

Molex Plug Clip

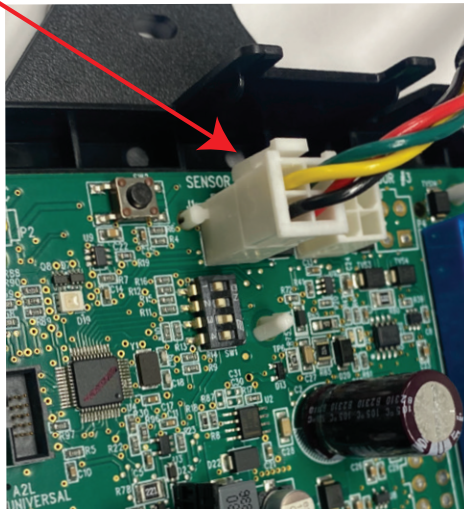

Figure 4. Connecting the RDS Sensor to RDS Blower Control Board

## Secondary Sensor

### Additional Line Set Joints

If additional joints are present outside of the line set sleeve, the system installation must comply with one of the options listed. Refer to Refrigerant Detection Sensor Kit Installation Instructions Form# (508467-01); see Line Set Joints.

### Multiple Systems Installed in Same Space

For any Low GWP refrigerant system with additional joints not covered by line set joint sleeves, each system in the same space must have refrigerant detection sensor installed below the level of the burners.

If a secondary refrigerant sensor is required, it must be mounted as follows:

- **Upflow Applications:** Mounted on an unused side furnace return air connection at least nine (9) inches above the floor and within nine(9) inches from front of furnace.
- **Horizontal Applications:** Mounted on the lower section of the side return furnace air connection, within nine(9) inches of both the blower deck and front of furnace.
- **Downflow Applications:** Mounted on one side of the evaporator coil nine(9) inches above the floor and within nine(9) inches from front of coil.

Connect the refrigerant sensor to the second sensor input on the RDS Control. Refer to the instructions provided with the sensor or the RDS controller to enable the second sensor (see "DIP Switch Settings" on page 12).

## DIP Switch Settings

### Default Switch DIP Settings

The following are the default DIP switch settings:

- DIP Switch 1 → OFF
- DIP Switch 2 → OFF

The default setting requires the RDS Control Board to have two (2) sensors installed.

The sensor settings must be adjusted according to the number of sensors installed. If a second sensor is not installed (in Sensor 2 plug), DIP Switch 2 must be turned to the ON position.

### Non-Default Configurations

Adjust the DIP switch settings to the sensor configuration. Failure to do so will cause faults on power-up.

Table 1. DIP Switch Settings

Configuration	Switch 1	Switch 2	Switch 3	Switch 4
One (1) sensor, connected to SENSOR 1 plug	OFF	ON	N/A	N/A
Two (2) sensors, connected to SENSOR 1 plug and SENSOR 2 plug	OFF	OFF	N/A	N/A

In single sensor configurations, the sensor must be connected to the SENSOR 1 plug. Configurations other than the ones shown in Table 1 will cause a service fault.

Each DIP switch corresponds to a sensor position (i.e., DIP switch 1 to sensor 1; DIP switch 2 to sensor 2). The default factory switch positions are set to OFF. The RDS Blower Control Board software reads the OFF position as an active sensor. A sensor should be present for the corresponding sensor connector. Setting the DIP switch to ON disables the sensor position.

**NOTE:** Refer to 508467-01 (*Installation Instructions for Refrigerant Leak Detection Sensor Kit - Indoor Coils*) to determine whether more than one (1) Refrigerant Detector Sensor is required.

## Modes of Operation

The modes of operation for the RDS Blower Control Board are Initializing, Normal, Refrigerant Detected, and Fault.

### Initializing

The RDS Blower Control Board is establishing connection with the refrigerant detection sensor and is completing an initial five-minute purge sequence.

### Normal

The HVAC system is functioning normally. The RDS Blower Control Board has not detected refrigerant.

## Refrigerant Detected

When the RDS Blower Control Board detects refrigerant:

1. The RDS Blower Control Board shuts off the (R) input (24VAC power) to the thermostat, which de-energizes the outdoor unit compressor and heat sources, such as gas and/or electric strip heat. No heating or cooling demands will be met.
2. The RDS Blower Control Board activates the blower (high speed). The blower purges refrigerant from the cabinet, plenum, and ductwork.
3. After the RDS Blower Control Board determines the refrigerant levels are below the UL standard threshold, the blower will continue to operate for the remainder of the seven (7) -minute cycle.
4. After the blower sequence is complete, the HVAC system resumes normal operation.

**NOTE:** *The HVAC system may not maintain a cooling or heating setpoint if a significant leak exists. Any refrigerant leaks that remain unaddressed for an extended time may cause the HVAC system to shut down on a low refrigerant pressure limit condition.*

## Sensor Not Connected

If no sensors are connected to the RDS Control Board, the LED will flash red four (4) times, indicating a service fault (sensor communication issue). Heat/Cool operation is still permissible and the blower motor will run continuously at a high speed.

## Fault

When a fault is detected within the RDS Blower Control Board, the indoor unit blower engages and remains engaged at a constant output until the fault is cleared.

## Diagnostic Codes

The RDS Blower Control Board is equipped with a multicolor LED within its enclosure. The LED signals the state of the RDS Blower Control Board.

See Table 2 to review the diagnostic codes.

**Table 2. LED Diagnostic Codes**

State	LED Diagnostic Code	Action
Initializing	Flashing green <sup>1</sup>	Not Applicable
Monitoring	Solid green with blue flash <sup>2</sup>	Not Applicable
Mitigating (Refrigerant Detected)	Flashing blue	Check coil tubes for leak. Repair the issue and restart the equipment.

**Table 2. LED Diagnostic Codes**

State	LED Diagnostic Code	Action
Fault/Service	Solid blue, interrupted by issue flash code	Refer to Table 7 for troubleshooting steps.

1. A rapid flash indicates the RDS Blower Control Board is in the process of sensor enumeration

2. A blue flash indicates a purge has previously occurred.

### Red LED Diagnostic Codes

Red diagnostic codes indicate a specific RDS Blower Control Board issue. Yellow diagnostic codes indicate the sensor's position (if applicable).

**Table 3. Red LED Diagnostic Codes**

Red Flash	Applies to Individual Sensor(s)	Issue	Action
1	Yes	Sensor indicates fault	Replace the sensor (See "Refrigerant Detection System Sensors" on page 8).
2	No	Spare Code - Unused	Not Applicable

**Table 3. Red LED Diagnostic Codes**

Red Flash	Applies to Individual Sensor(s)	Issue	Action
3	Yes	Incompatible sensor type	Replace with a compatible sensor See "Refrigerant Detection System Sensors" on page 8).
4	Yes	Sensor communications issue	<ul style="list-style-type: none"> <li>Verify sensor DIP switch settings are correct.</li> <li>Verify sensor connection is secure.</li> <li>Ensure connection is clean and free of debris.</li> </ul>
5	No	Indoor unit wiring connected incorrectly to the "Black TSTAT" terminal strip on the RDS Non-Communicating Control Board	<ul style="list-style-type: none"> <li>Check wiring connections.</li> <li>Ensure the indoor unit is wired to the "Blue INDOOR" terminal strip.</li> <li>Verify the Room Thermostat is wired to the "Black TSTAT" terminal strip.</li> </ul>

**Table 3. Red LED Diagnostic Codes**

Red Flash	Applies to Individual Sensor(s)	Issue	Action
6	No	Invalid configuration of sensor count	Verify the DIP switch setting is correct and matches the number of sensors being used.

## Test Button Functionality

The RDS Blower Control Board is equipped with a Test/Reset button. The Test button can be used to complete several functions, depending on the mode of operation of the RDS Blower Control Board.

Table 4 lists the functions of the Test button during each mode of operation.

**Table 4. Test Button Function**

Mode of Operation	Press the Test Button to...
Normal	Trigger a refrigerant detection response. Verify all equipment is wired correctly into the RDS Blower Control Board (after installation).
Refrigerant Detected	Reset the RDS Blower Control Board to a normal mode of operation after refrigerant has been detected and purged from the HVAC system.

**Table 4. Test Button Function**

Mode of Operation	Press the Test Button to...
Fault	Reset the RDS Blower Control Board after troubleshooting and resolving a fault condition. If the fault is not resolved, the RDS Blower Control Board will enter the Fault mode again.

## Test Button - Additional Functions

Table 5 lists the additional functions of the Test Button while the RDS Blower Control Board is functioning within the states of Initializing, Monitoring, Refrigerant Detection, Servicing and Fault. Refer to “Table 2. LED Diagnostic Codes” on page 13.

**Table 5. Additional Button Functions**

State	Press	Action
Initializing	Short	Skips remaining pre-purge after sensors are recognized by the RDS Blower Control Board
Initializing	Long	Reset control
Monitoring	Short	Clear purge-counter if prior mitigation has occurred; Test mitigation
Monitoring	Long	Reset control
Mitigating	Short	If testing mitigation, end test
Servicing	Short	Reevaluate fault condition - if cleared return to monitoring, otherwise update indicator

**Table 5. Additional Button Functions**

State	Press	Action
Servicing	Long	Reset control
Fault	Short	Reevaluate fault condition - if cleared return to monitoring, otherwise update indicator
Fault	Long	Reset control

## Thermostat Compatibility

Thermostats that preserve memory settings are compatible with the RDS Blower Control Board. Examples include:

- Battery-powered thermostats
- Analog thermostats
- Smart thermostats
- Lennox communicating thermostats (S30 or S40)
- Late-model programmable thermostats

**NOTE:** *Early-generation digital and programmable thermostats may not retain the operation mode and temperature setpoints after a power outage.*

The following scenarios are likely to occur when home occupants are not available to adjust the thermostat setpoints as the system is recovering from refrigerant detection and resuming normal operation:

- Heating could be lost during a cold night
- Cooling could be lost during a hot day
- The thermostat could reset to an incorrect temperature setpoint

## Compatibility Verification

Complete the following process to determine whether the thermostat is compatible with the RDS Blower Control Board.

1. Change the thermostat's current setpoint and operating mode.
2. Power cycle the breaker to the furnace.

**NOTE:** *Wait five (5) minutes before supplying power to the furnace breaker.*

3. Note whether the thermostat maintained its setpoints and operating mode.
  - a. If the thermostat maintained the settings, the thermostat is compatible with the RDS Blower Control Board.
  - b. If the thermostat did not maintain its setpoint and/or operating mode, the thermostat is not compatible with the RDS Blower Control Board. Recommend a compatible thermostat.

## Additional Applications

In zoned applications, all dampers will remain open when the RDS Blower Control Board is in Fault or Refrigerant Detected mode. Normal heating and cooling demands are permissible, but the blower will remain engaged until the fault condition is addressed.

### Zone HVAC System

If the RDS Blower Control Board is installed in a zone HVAC system, the RDS Blower Control Board will open all zone dampers if refrigerant is detected.

**NOTE:** *Proper wiring of the zone panel to the RDS Blower Control Board is required for all zone dampers to open.*

After the purge sequence is complete, the zone system will resume normal operation.

### External Alarm

*(For applications with external alarms wired directly to the RDS Blower Control Board.)*

The RDS Blower Control Board triggers the external alarm system when it enters Refrigerant Detected mode. For alarm notifications, the RDS Blower Control Board provides a dry relay contact that is rated 3A at 30 VAC/DC.

## Start Up Test Procedure

The RDS Blower Control Board is equipped with a Test/Reset button, see “Test Button Functionality” on page 15. “After the RDS Blower Control Board has been mounted and wired, restore power to the HVAC system. The system will then run through a purge sequence for five minutes. After the purge sequence is complete, proceed to testing cooling demand and heating demand.

### Cooling Demand

1. Prompt a cooling demand at the thermostat.
2. Press the Test button on the RDS Blower Control Board.

The system then executes a refrigerant detection response.

3. Observe the following sequence:
  - a. The LED indicator flashes the sequence for refrigerant detection (flashing blue).
  - b. The blower powers up.
  - c. The outdoor compressor powers down.
4. Press the Test button to terminate the simulated Refrigerant Detected mode upon test completion.

## Heating Demand

1. Prompt a heating demand at the thermostat.
2. Press the Test button on the RDS Blower Control Board.  
  
The system then executes a refrigerant detection response.
3. Observe the following sequence:
  - a. The LED indicator flashes the sequence for refrigerant detection (flashing blue).
  - b. The blower powers up.
  - c. The gas burners power down.
  - d. The outdoor compressor powers down.
4. Press the Test button to terminate the simulated Refrigerant Detected mode upon test completion.

The installation of the RDS Blower Control Board is complete after both sequences are successfully completed.

## Wiring Diagrams

Lennox provides wires designated for wiring the sensor cable. Wires required for the RDS installation is field supplied.

The RDS supports all OEM and non-OEM gas furnace installations. Wiring diagrams are provided for several common split furnace system configurations to identify exact wire types and terminal locations.

### Communicating Indoor Controls and Float Switch

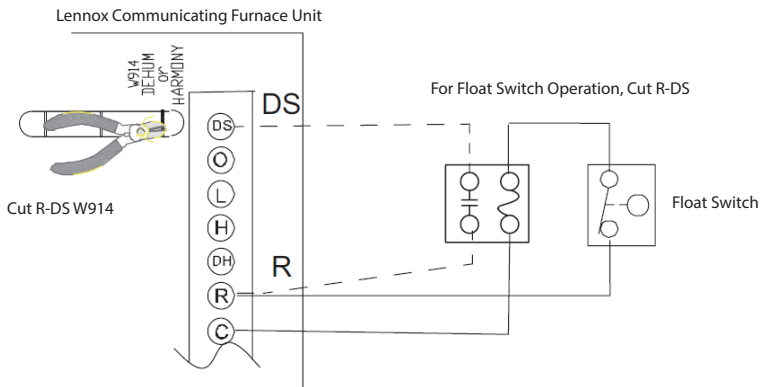

# Communicating Thermostat with Furnace and Outdoor Units

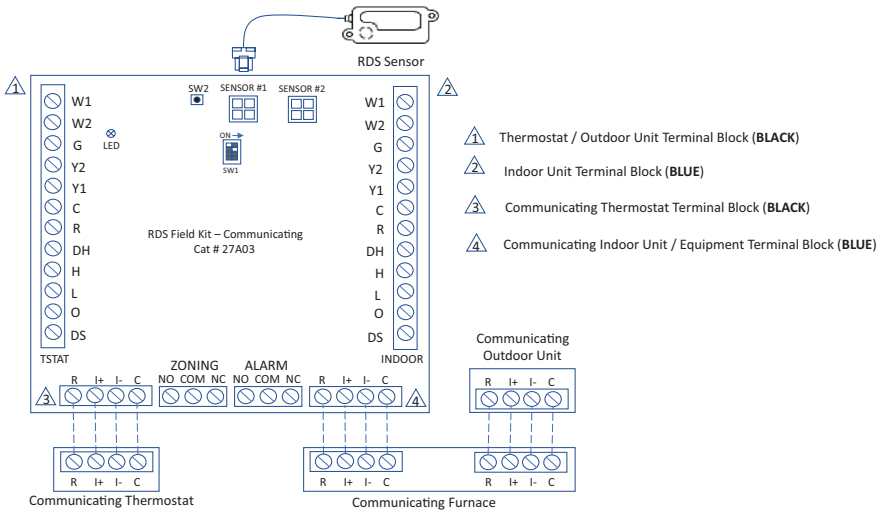

## Communicating Thermostat, Communicating Furnace with EIM, and Non-Communicating Two Stage Heat Pump

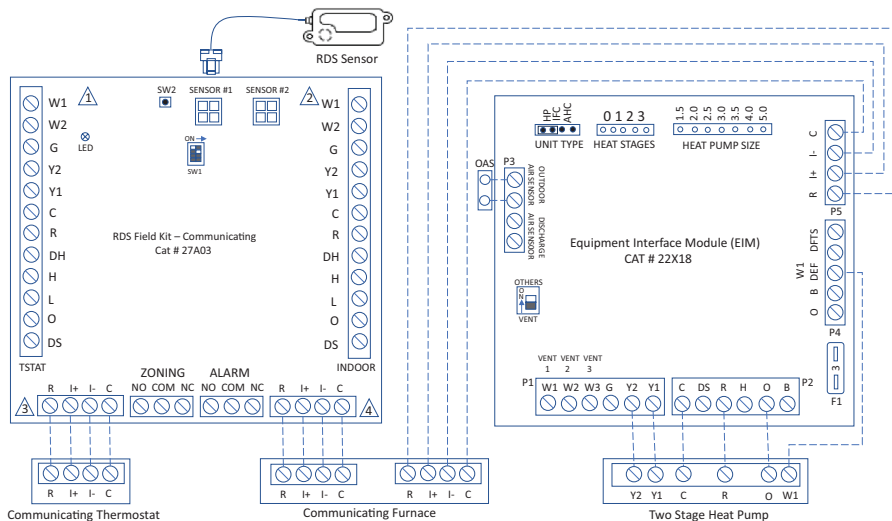

- 1 Thermostat / Outdoor Unit Terminal Block (**BLACK**)
- 2 Indoor Unit Terminal Block (**BLUE**)
- 3 Communicating Thermostat Terminal Block (**BLACK**)
- 4 Communicating Indoor Unit / Equipment Terminal Block (**BLUE**)

# Non-Communicating Thermostat, Communicating Two Stage Furnace with Non-Communicating Two Stage Outdoor Unit

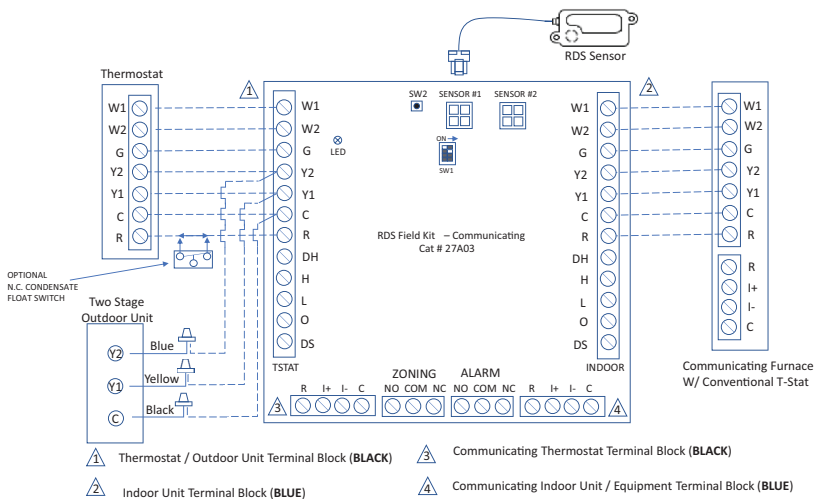

## Communicating Thermostat with Communicating Furnace and Non-Communicating Two Stage Outdoor Units

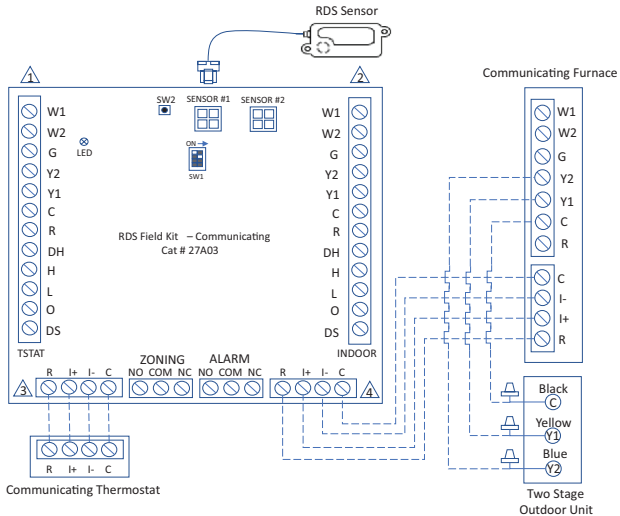

- ① Thermostat / Outdoor Unit Terminal Block (**BLACK**)
- ② Indoor Unit Terminal Block (**BLUE**)
- ③ Communicating Thermostat Terminal Block (**BLACK**)
- ④ Communicating Indoor Unit / Equipment Terminal Block (**BLUE**)

## Communicating Zoning with Communicating Thermostat, Communicating Indoor and Outdoor Units

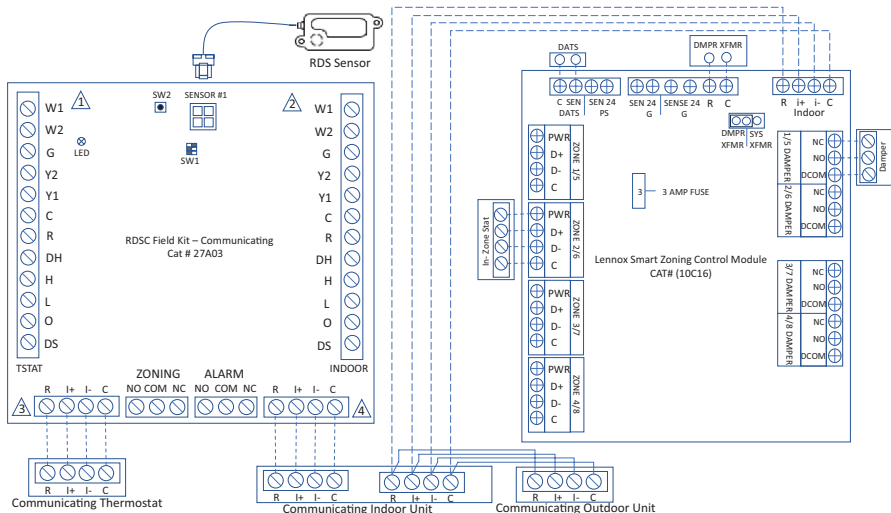

- 1 Thermostat / Outdoor Unit Terminal Block (BLACK)
- 2 Indoor Unit Terminal Block (BLUE)
- 3 Communicating Thermostat Terminal Block (BLACK)
- 4 Communicating Indoor Unit / Equipment Terminal Block (BLUE)

## Diagnostic Codes and Troubleshooting

**Table 6. LED Diagnostic Codes**

State	LED Diagnostic Code	Action Required
Initializing	Flashing green	None
Monitoring	Solid green. If a prior mitigation occurred, a blue flash interrupts the solid green LED.	None
Mitigating (Refrigerant Detected)	Flashing blue	Check coil tubes for refrigerant. Repair the issue and restart the equipment.
Fault/Service	Solid blue, interrupted by issue diagnostic code	Refer to Table 7 for troubleshooting steps.

**Table 7. Red LED Diagnostic Codes / Troubleshooting**

Red Flash	Applies to Individual Sensor(s)	Issue	Action Required
1	Yes	Sensor indicates fault	Replace the sensor (See "Refrigerant Detection System Sensors" on page 8).
2	No	Spare Code - Unused	Not Applicable
3	Yes	Incompatible sensor type	Replace the sensor (See "Refrigerant Detection System Sensors" on page 8).
4	Yes	Sensor communications issue	<ul style="list-style-type: none"> <li>• Verify sensor DIP switch settings are correct.</li> <li>• Verify sensor connection is secure.</li> <li>• Ensure connection is clean and free of debris.</li> </ul>

**Table 7. Red LED Diagnostic Codes / Troubleshooting**

<b>Red Flash</b>	<b>Applies to Individual Sensor(s)</b>	<b>Issue</b>	<b>Action Required</b>
5	No	Indoor unit wiring incorrectly connected to the "Black TSTAT" terminal strip on the RDS control.	<ul style="list-style-type: none"><li>• Check wiring connections.</li><li>• Ensure the indoor unit is wired to the "Blue INDOOR" terminal strip.</li><li>• Verify the Room Thermostat is wired to the "Black TSTAT" terminal strip.</li></ul>
6	No	Invalid configuration of sensor count	Verify the DIP switch setting is correct and matches the number of sensors being used.

