

INSTALLATION INSTRUCTIONS

⚠ WARNING

Improper installation, adjustment, alteration, service or maintenance can cause property damage, personal injury or loss of life. Installation and service must be performed by a licensed professional HVAC installer or equivalent, service agency, or the gas supplier.

⚠ CAUTION

As with any mechanical equipment, contact with sharp sheet metal edges can result in personal injury. Take care while handling this equipment and wear gloves and protective clothing.

Table of Contents

Unit Dimensions	4
Parts Arrangement	7
Shipping and Packing List	8
General	8
Requirements	8
Unit Support	10
Duct Connection	11
Rigging for Lifting	11
Condensate Drains	11
Connect Gas Piping	12
Pressure Test Gas Piping	13
Electrical Connections - Power Supply	13
Electrical Connections - Control Wiring	14
Mobile Service App	16

- LGT/LCT156H** (13 Ton)
- LGT/LCT180H** (15 Ton)
- LGT/LCT210H** (17.5 Ton)
- LGT/LCT240H** (20 Ton)
- LGT/LCT300H** (25 Ton)

ROOFTOP PACKAGED UNITS

508458-02
06/2026
Supersedes 508458-01

R-454B

Blower Operation and Adjustments	18
Refrigerant Leak Detection System	25
Cooling Start-Up	25
Diagnostic Sensors	57
Gas Heat Start-Up (Gas Units)	66
Gas Heating Operation	67
Gas Heating Checks and Adjustments	68
Electric Heat Start-Up (LCT Units)	69
Multi-Stage Air Volume Start-Up	69
Sequence Of Operation	72
Hot Gas Reheat Start-Up	80
Preventative Maintenance / Repair	84
Factory Unit Controller Settings	92
Decommissioning	96

RETAIN THESE INSTRUCTIONS FOR FUTURE REFERENCE

Attention!

Use this QR code to download the mobile service app. Follow the prompts to pair the app with the Unit Controller. Refer to the "Mobile Service App" section in this manual. The QR code is also available in the unit control area.



The app can be downloaded from the appropriate iOS or Android store. Look for the following icon.



⚠ CAUTION

As with any mechanical equipment, contact with sharp sheet metal edges can result in personal injury. Take care while handling this equipment and wear gloves and protective clothing.

⚠ WARNING

Only manufacturer approved auxiliary devices are permitted to be installed in this unit.

⚠ WARNING

If this appliance is conditioning a space with an area smaller than T_{Amin} or stored in a space with an area smaller than A_{min} as defined by this instruction, then that space must be without continuously operating open flames (e.g. an operating gas appliance) or other potential ignition sources (e.g. an operating electric heater or similar hot surface). A flame-producing device may be installed in the same space if the device is provided with an effective flame arrest system.

⚠ CAUTION

Auxiliary devices which may be a potential ignition source shall not be installed in the duct work. Examples of such potential ignition sources are hot surfaces with a temperature exceeding 700°C and electric switching devices.

⚠ CAUTION

The appliance is not to be used by persons (including children) with reduced physical, sensory or mental capabilities, or lack of experience and knowledge, unless they have been given supervision or instruction.

⚠ CAUTION

Children should be supervised not to play with the appliance.

⚠ CAUTION

Any personnel installing, decommissioning, or performing maintenance on the unit must be properly trained with A2L refrigerants.

⚠ CAUTION

Leak Detection System installed. Unit must be powered except for service.

⚠ CAUTION

Servicing shall be performed only as recommended by the manufacturer.

⚠ WARNING

•This appliance must be installed in accordance with local and national wiring regulations.

•If the appliance is not fitted with an option for full disconnection from power, a means of disconnection must be incorporated in the fixed wiring in accordance with national and local wiring regulations.

⚠ CAUTION

Leak Detection System installed. Unit must be powered except for service.

⚠ WARNING

•Do not use means to accelerate the defrosting process or to clean, other than those recommended by the manufacturer.

•The appliance shall be stored in a room without continuously operating ignition sources (for example: open flames, an operating gas appliance, or an operating electric heater).

•Do not pierce or burn.

•Be aware that refrigerants may not contain an odor

⚠ WARNING

Ducts connected to an appliance shall not contain a potential ignition source.

⚠ IMPORTANT

Pipe work, including piping material, pipe routing, and installation shall include protection from physical damage in operation and service, and be in compliance with national and local codes and standards, such as ASHRAE 15, ASHRAE 15.2, IAPMO Uniform Mechanical Code, ICC International Mechanical Code, or CSA B52. All field joints shall be accessible for inspection prior to being covered or enclosed.

⚠ IMPORTANT

Refrigerant sensors for refrigerant detection systems shall only be replaced with sensors specified by the appliance manufacturer.

⚠ CAUTION

This unit is equipped with electrically powered safety measures. To be effective, the unit must be electrically powered at all times after installation, other than when servicing.

A2L Refrigerant Considerations

Ensure that the area is in the open or that it is adequately ventilated before breaking into the system or conducting any hot work. A degree of ventilation shall continue during the period that the work is carried out. The ventilation should safely disperse any released refrigerant and preferably expel it externally into the atmosphere.

Check that cabling will not be subject to wear, corrosion, excessive pressure, vibration, sharp edges or any other adverse environmental effects, taking into account the effects of aging or continual vibration from sources such as compressors or fans.

Under no circumstances shall potential sources of ignition be used when searching for or for detection of refrigerant leaks. A halide torch (or any other detector using a naked flame) shall not be used. Electronic leak detectors may be used to detect refrigerant leaks but, in the case of flammable refrigerants, the sensitivity may not be adequate, or may need re-calibration. (Detection equipment shall be calibrated in a refrigerant-free area.) Ensure that the detector is not a potential source of ignition and is suitable for the refrigerant used. Leak detection equipment shall be set at a percentage of the LFL of the refrigerant and shall be calibrated to the refrigerant employed, and the appropriate percentage of gas (25% maximum) is confirmed. Leak detection fluids are also suitable for use with most refrigerants but the use of detergents containing chlorine shall be avoided as the chlorine may react with the refrigerant and corrode the copper pipe-work. If a leak is suspected, all naked flames shall be removed/extinguished. If a leakage of refrigerant is found which requires brazing, all of the refrigerant shall be recovered from the system, or isolated (by means of shut off valves) in a part of the system remote from the leak.

When breaking into the refrigerant circuit to make repairs – or for any other purpose – conventional procedures shall be used. However, for flammable refrigerants it is important that best practices be followed since flammability is a consideration. The following procedure shall be adhered to:

- Safely remove refrigerant following local and national regulations.
- Evacuate the circuit.
- Purge the circuit with inert gas.
- Evacuate.
- Purge the circuit with inert gas.
- Open the circuit

The refrigerant charge shall be recovered into the correct recovery cylinders if venting is not allowed by local and national codes. For appliances containing flammable refrigerants, the system shall be purged with oxygen-free nitrogen to render the appliance safe for flammable refrigerants. This process might need to be repeated several times. Compressed air or oxygen shall not be used for purging refrigerant systems. Refrigerants purging shall be achieved by breaking the vacuum in the system with oxygen-free nitrogen and continuing to fill until the working pressure is achieved, then venting to atmosphere, and finally pulling down to a vacuum. This process shall be vented down to atmospheric pressure to enable work to take place. Ensure that the outlet for the vacuum pump is not close to any potential ignition sources and that ventilation is available.

⚠ WARNING

To prevent serious injury or death:

- 1- Lock-out, tag-out before performing maintenance.
- 2- If system power is required (e.g., smoke detector maintenance), disable power to blower, remove fan belt where applicable, and ensure all controllers and thermostats are set to the OFF position before performing maintenance.
- 3- Always keep hands, hair clothing, jewelry, tools, etc., away from moving parts.

LGT/LCT156H Unit Dimensions - Inches (mm) - Gas Heat Section Shown

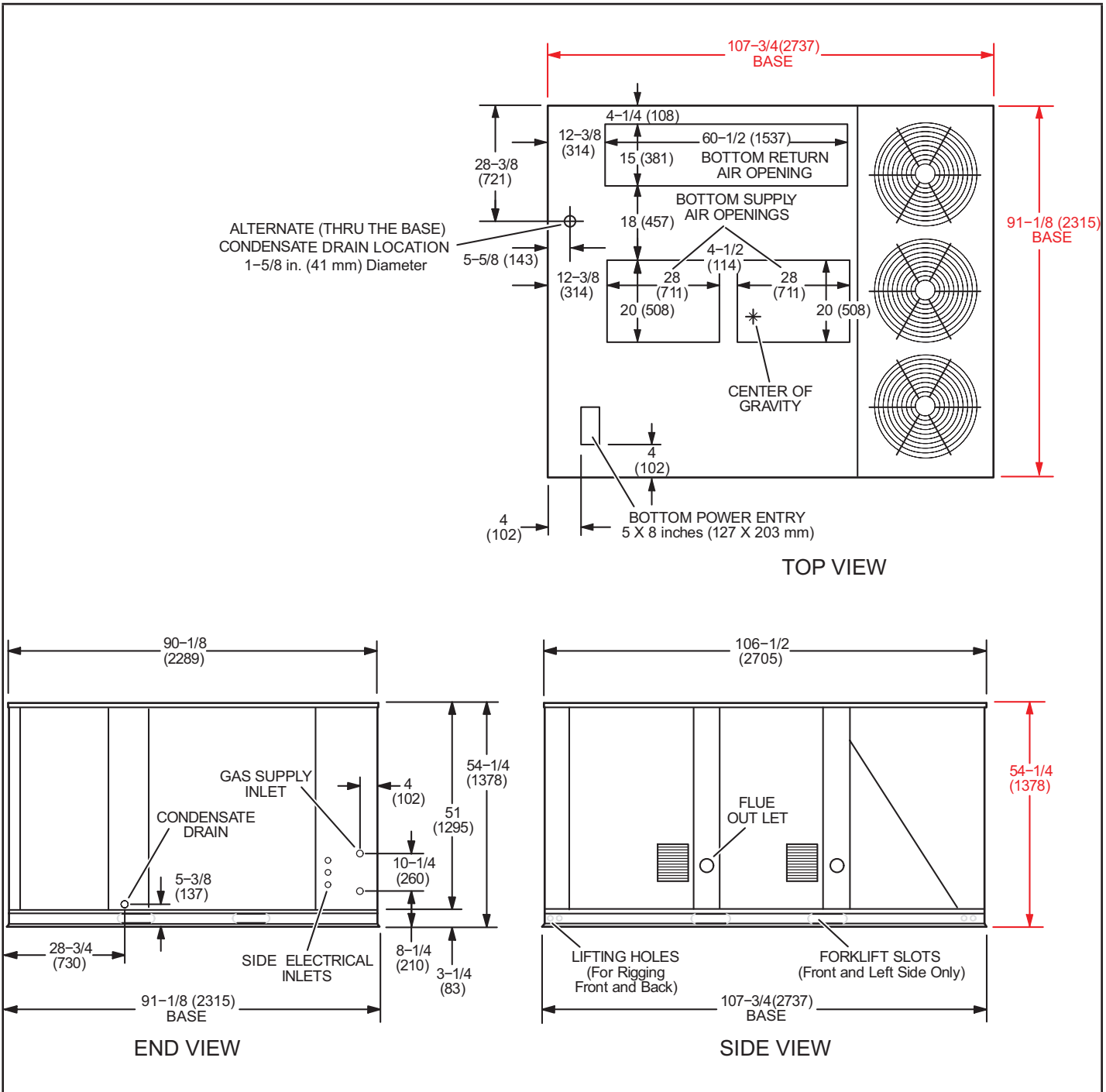

LGT/LCT180H, 210H Unit Dimensions - Inches (mm) - Gas Heat Section Shown

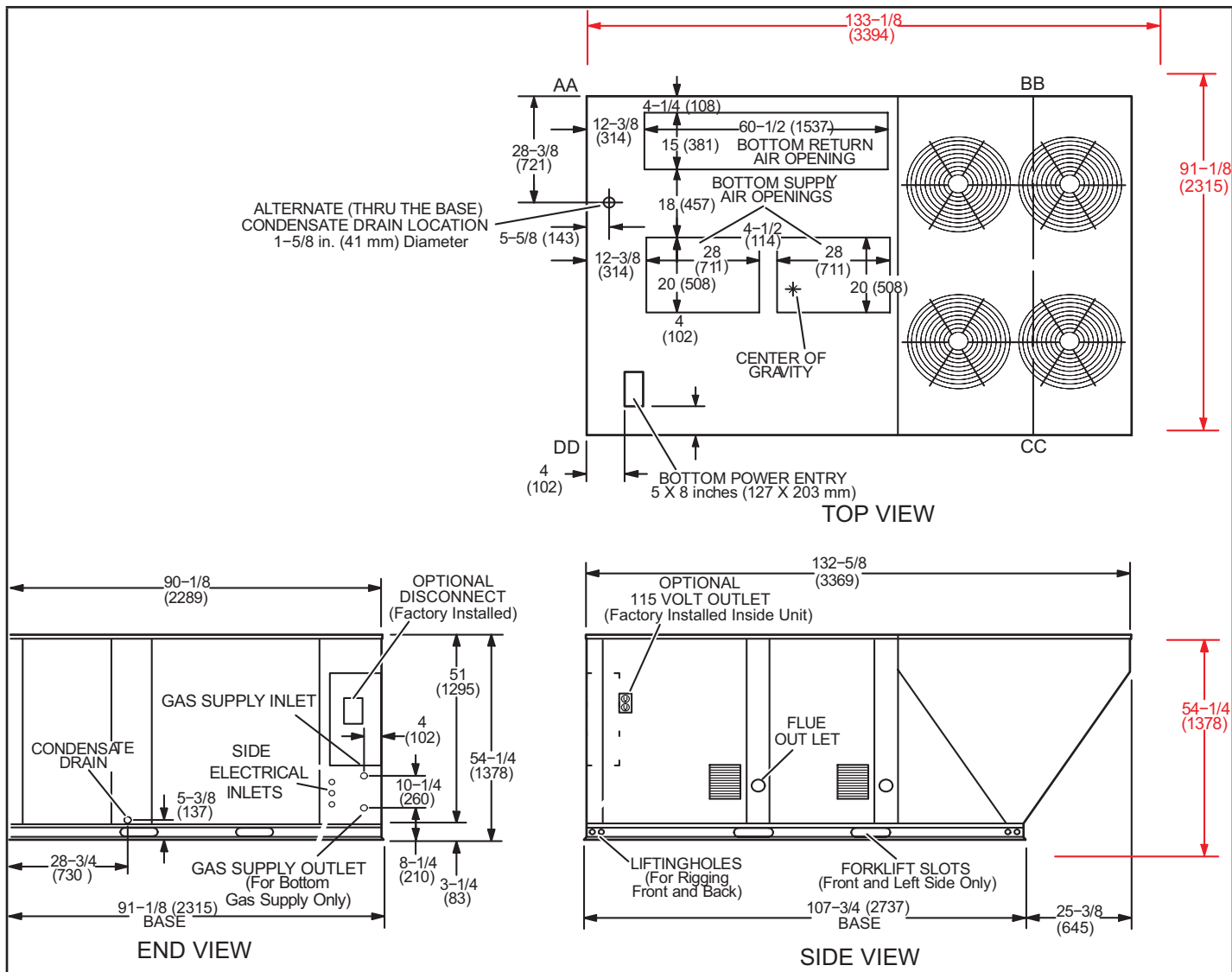

LGT/LCT240H, 300H Unit Dimensions - Inches (mm) - Gas Heat Section Shown

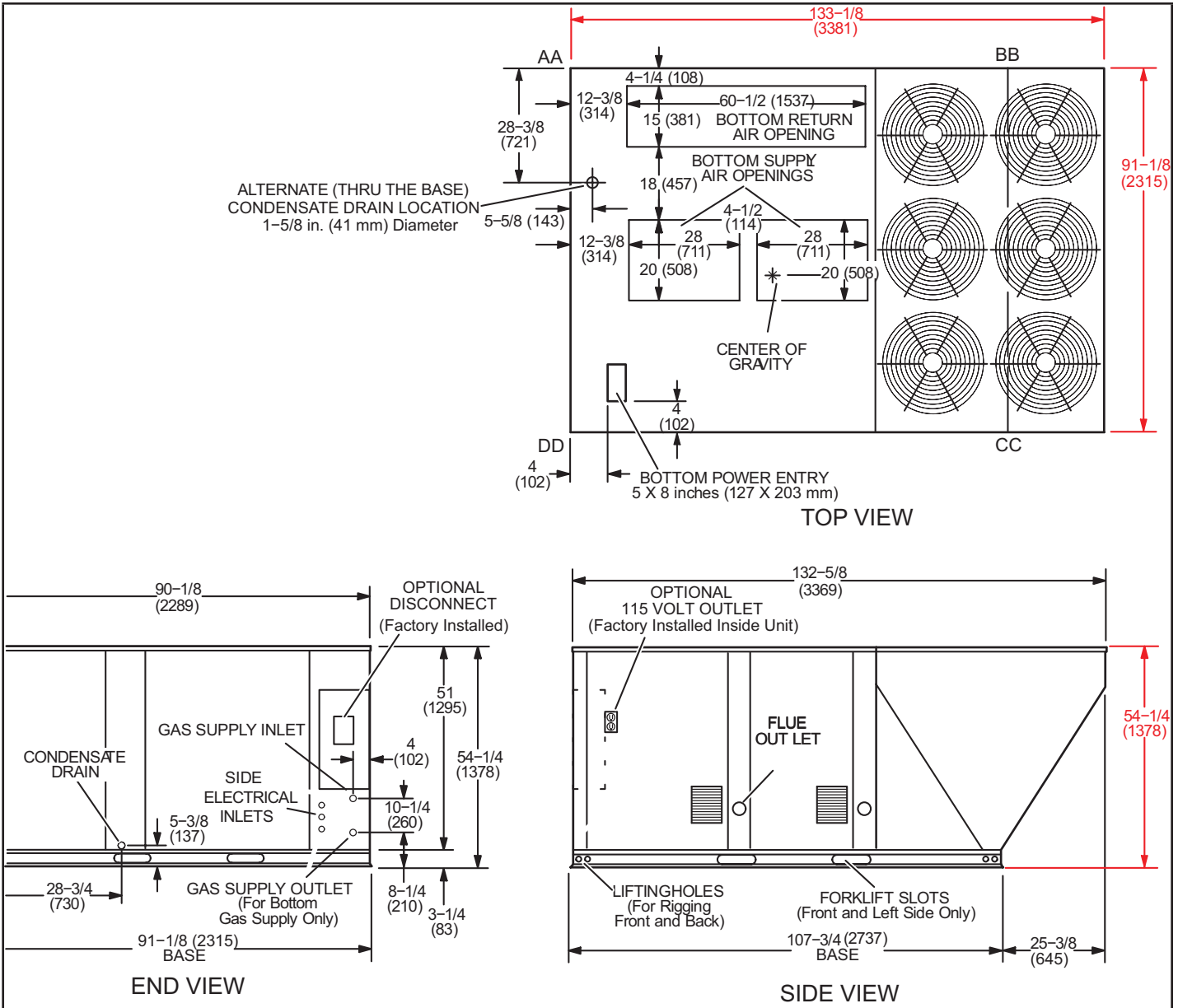

LGT 156, 180, 210, 240, 300 Parts Arrangement

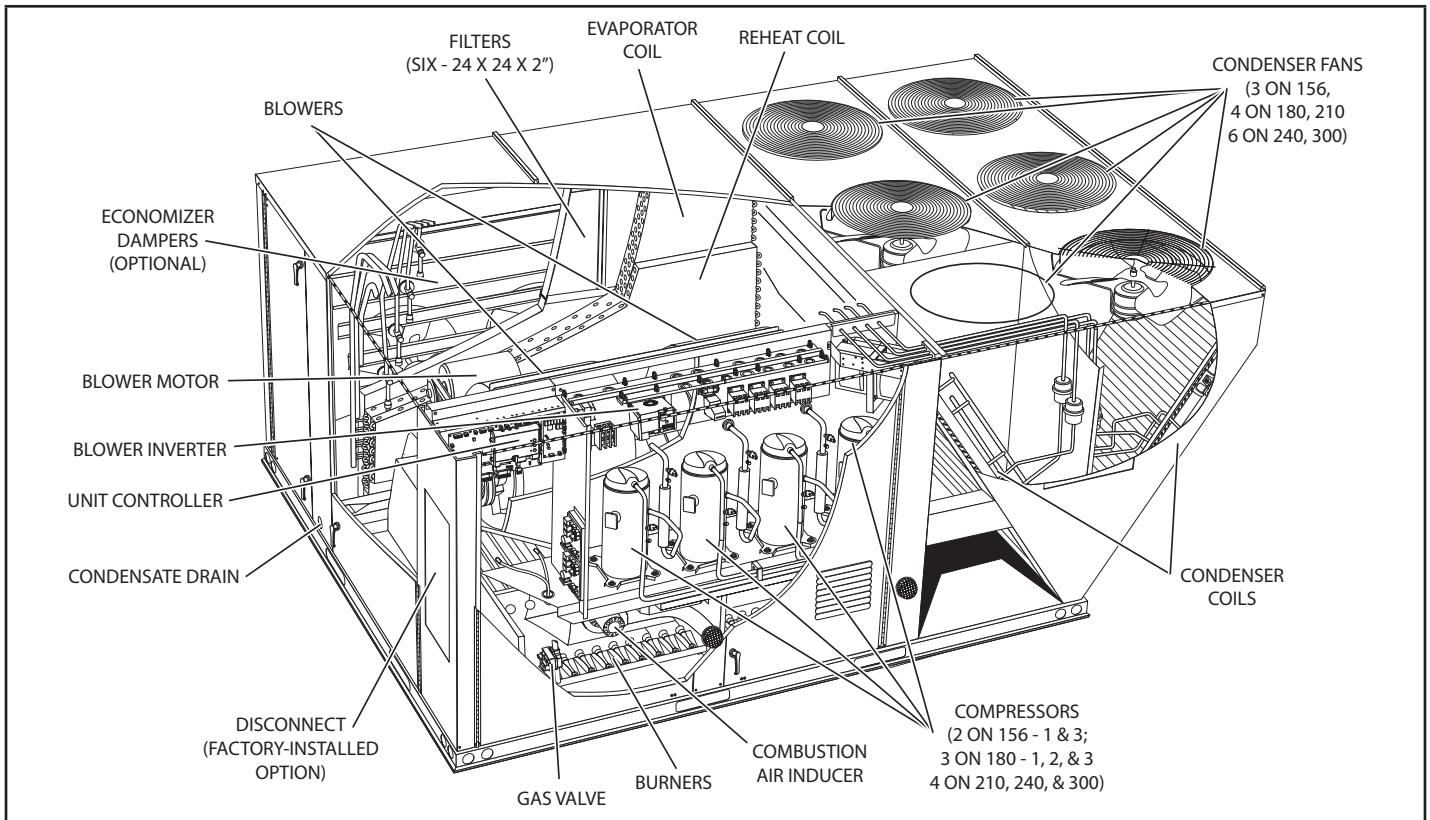

LCT 156, 180, 210, 240, 300 Parts Arrangement

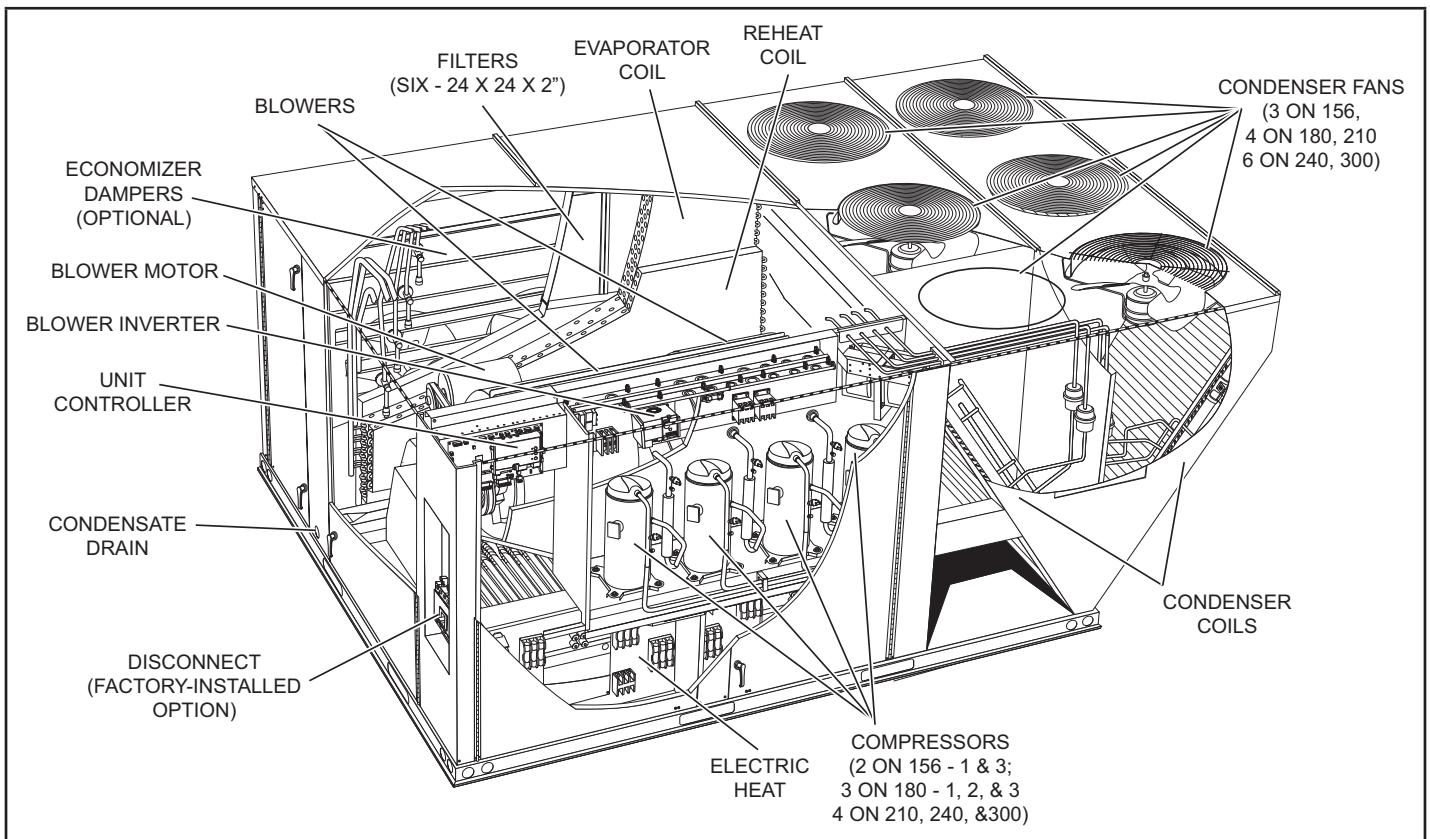

Shipping and Packing List

Package 1 of 1 contains:

1 - Assembled unit

Check unit for shipping damage. Receiving party should contact last carrier immediately if shipping damage is found.

General

These instructions are intended as a general guide and do not supersede local codes in any way. Authorities having jurisdiction should be consulted before installation.

The LGT156H gas/electric packaged rooftop unit is available in 169,000, 260,000, & 360,000 Btuh heating input. The LGT180, 210, 240, & 300 gas/electric packaged rooftop units are available in 260,000, 360,000, or 480,000 Btuh heating inputs.

The LCT cooling packaged rooftop unit is the same basic design as the LGT unit except for the heating section. Optional electric heat is factory- or field-installed in LCT units.

LGT and LCT units have identical refrigerant circuits with respective 13, 15, 17-1/2, 20 and 25 ton cooling capacities. 156H units contain two compressors; compressor 1 is two speed and compressor 2 is fixed speed. 180H units contain three compressors; all are fixed speed. 210, 240 and 300 units contain four compressors; all are fixed speed compressors.

Units come standard with a factory-installed, all-aluminum condenser coil.

Units are available with an optional hot gas reheat coil which provides a dehumidifying mode of operation. Refer to Reheat Operation section.

Units are available with variable air volume or single-zone variable air volume. Refer to the 9th character of the model number to determine type of blower:

V - Variable Air Volume

M - Single-Zone Variable Air Volume

Units use R454B, an ozone-friendly HFC refrigerant. Refer to the Cooling Start-Up section for precautions when installing unit.

⚠ WARNING



Electric shock hazard and danger of explosion. Can cause injury, death or product or property damage. Turn off gas and electrical power to unit before performing any maintenance or servicing operations on the unit. Follow lighting instructions attached to unit when putting unit back into operation and after service or maintenance.

Requirements

See FIGURE 1 for unit clearances.

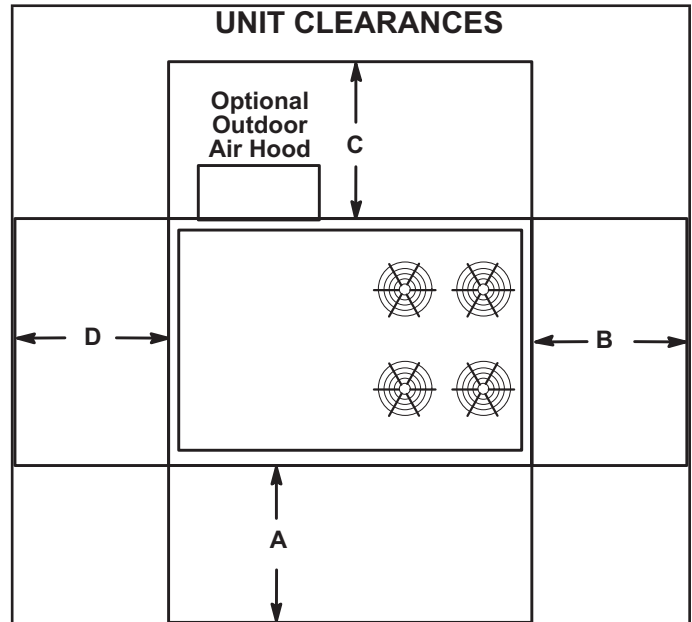

FIGURE 1

Unit Clearance	A in.(mm)	B in.(mm)	C in.(mm)	D in.(mm)	Top Clearance
Service Clearance	60 (1524)	36 (914)	36 (914)	66 (1676)	Unobstructed
Clearance to Combustibles	36 (914)	1 (25)	1 (25)	1 (25)	Unobstructed
Minimum Operation Clearance	36 (914)	36 (914)	36 (914)	41 (1041)	Unobstructed

NOTE - Entire perimeter of unit base requires support when elevated above mounting surface.

Service Clearance - Required for removal of serviceable parts

Clearance to Combustibles - Required clearance to combustible material (gas units). On LCT units, see clearance to combustible materials on heater rating plate.

Minimum Operation Clearance - Required clearance for proper unit operation.

Minimum R454B Space and CFM Requirements

Minimum Airflow ¹		
Unit	Q _{min} (CFM)	Q _{min} (m ³ h)
LCT/LGT156	238	404
LCT/LGT180	156	265
LCT/LGT210	155	264
LCT/LGT240	178	303
LCT/LGT300	157	267
LCT/LGT156 W/ Humidrol	238	404
LCT/LGT180 W/ Humidrol	170	289
LCT/LGT210 W/ Humidrol	177	300
LCT/LGT240 W/ Humidrol	172	292
LCT/LGT300 W/ Humidrol	169	286

¹ **NOTE** - The minimum airflow is the lowest CFM allowed during venting operation (leak mitigation).

Minimum Room Area of Conditioned Space ²		
Unit	TA _{min} (ft ²)	TA _{min} (m ²)
LCT/LGT156	132	12.25
LCT/LGT180	87	8.03
LCT/LGT210	87	8.00
LCT/LGT240	99	9.19
LCT/LGT300	88	8.08
LCT/LGT156 W/ Humidrol	132	12.25
LCT/LGT180 W/ Humidrol	95	8.76
LCT/LGT210 W/ Humidrol	99	9.10
LCT/LGT240 W/ Humidrol	96	8.85
LCT/LGT300 W/ Humidrol	94	8.68

² **NOTE** - The minimum room area of conditioned space is the smallest area the unit can service.

Refrigerant Charge R-454B		
Unit	M _c (lbs)	M _c (kg)
LGT/LCT156 STG 1	9.00	4.08
LGT/LCT156 STG 2	7.63	3.46
LGT/LCT180 STG 1	5.90	2.68
LGT/LCT180 STG 2	5.50	2.49
LGT/LCT180 STG 3	5.00	2.27
LGT/LCT210 STG 1	5.69	2.58
LGT/LCT210 STG 2	5.88	2.66
LGT/LCT210 STG 3	5.19	2.35
LGT/LCT210 STG 4	5.31	2.41
LGT/LCT240 STG 1	6.00	2.72
LGT/LCT240 STG 2	6.75	3.06
LGT/LCT240 STG 3	5.00	2.27
LGT/LCT240 STG 4	5.31	2.41
LGT/LCT300 STG 1	5.94	2.69
LGT/LCT300 STG 2	5.46	2.48
LGT/LCT300 STG 3	5.34	2.42
LGT/LCT300 STG 4	5.38	2.44
LGT/LCT156 STG 1 W/ Humidrol	9.00	4.08
LGT/LCT156 STG 2 W/ Humidrol	7.94	3.60
LGT/LCT180 STG 1 W/ Humidrol	6.44	2.92
LGT/LCT180 STG 2 W/ Humidrol	6.03	2.74
LGT/LCT180 STG 3 W/ Humidrol	6.00	2.72
LGT/LCT210 STG 1 W/ Humidrol	6.00	2.72
LGT/LCT210 STG 2 W/ Humidrol	6.69	3.03
LGT/LCT210 STG 3 W/ Humidrol	5.25	2.38
LGT/LCT210 STG 4 W/ Humidrol	5.00	2.27
LGT/LCT240 STG 1 W/ Humidrol	6.50	2.95
LGT/LCT240 STG 2 W/ Humidrol	6.50	2.95
LGT/LCT240 STG 3 W/ Humidrol	5.00	2.27
LGT/LCT240 STG 4 W/ Humidrol	5.00	2.27
LGT/LCT300 STG 1 W/ Humidrol	6.38	2.89
LGT/LCT300 STG 2 W/ Humidrol	6.13	2.78
LGT/LCT300 STG 3 W/ Humidrol	5.13	2.32
LGT/LCT300 STG 4 W/ Humidrol	5.75	2.61

Altitude Adjustment Factor ³									
Halt	0	200	400	600	800	1000	1200	1400	1600
AF	1	1	1	1	1.02	1.05	1.04	1.1	1.12
Halt	1600	1800	2000	2200	2400	2600	2800	3000	3200
AF	1.12	1.15	1.18	1.21	1.25	1.28	1.32	1.36	1.4

³ **NOTE** - Use the Altitude Adjustment Factor to adjust the values in the tables above to different altitudes. Find the relevant altitude above sea level in the two "Halt" rows and then multiply the value needed from the tables above by the altitude factor number. Example: For the minimum airflow in CFM for an LCT/LGT156 at 1000 ft. above sea level, multiply 238 by 1.05 to get 249.9 CFM as the new Q_{min}.

NOTICE

Roof Damage!

This system contains both refrigerant and oil. Some rubber roofing material may absorb oil, causing the rubber to swell. Bubbles in the rubber roofing material can cause leaks. Protect the roof surface to avoid exposure to refrigerant and oil during service and installation. Failure to follow this notice could result in damage to roof surface.

Use of this unit as a construction heater or air conditioner is not recommended during any phase of construction. Very low return air temperatures, harmful vapors and operation of the unit with clogged or misplaced filters will damage the unit.

If this unit has been used for heating or cooling of buildings or structures under construction, the following conditions must be met or the warranty will be void:

- The vent hood must be installed per these installation instructions.
- A room thermostat must control the unit. The use of fixed jumpers that will provide continuous heating or cooling is not allowed.
- A pre-filter must be installed at the entry to the return air duct.
- The return air duct must be provided and sealed to the unit.
- Return air temperature range between 55°F (13°C) and 80°F (27°C) must be maintained.
- Air filters must be replaced and pre-filters must be removed upon construction completion.
- The input rate and temperature rise must be set per the unit rating plate.
- The heat exchanger, components, duct system, air filters and evaporator coil must be thoroughly cleaned following final construction clean-up.
- The unit operating conditions (including airflow, cooling operation, ignition, input rate, temperature rise and venting) must be verified according to these installation instructions.

This appliance is not intended for use by persons (including children) with reduced physical, sensory, or mental capabilities, or lack of experience and knowledge, unless they have been given supervision or instruction concerning use of the appliance by a person responsible for their safety.

Unit Support

In downflow discharge installations, install the unit on a non-combustible surface only. Unit may be installed on combustible surfaces when used in horizontal discharge applications or in downflow discharge applications when installed on an LARMF18/36 roof mounting frame.

NOTE - Securely fasten roof frame to roof per local codes.

CAUTION

To reduce the likelihood of supply / return air by pass and promote a proper seal with the RTU, duct work / duct drops / diffuser assemblies must be supported independently to the building structure.

A-Downflow Discharge Application

Roof Mounting with LARMF18/36

- 1 - The LARMF roof mounting frame must be installed, flashed and sealed in accordance with the instructions provided with the frame.
- 2 - The LARMF roof mounting frame should be square and level to 1/16" per linear foot (5mm per linear meter) in any direction.
- 3 - Duct must be attached to the roof mounting frame and not to the unit; supply and return plenums must be installed before setting the unit.

Installer's Roof Mounting Frame

Many types of roof frames can be used to install the unit depending upon different roof structures. Items to keep in mind when using the building frame or supports are:

- 1 - The base is fully enclosed and insulated, so an enclosed frame is not required.
- 2 - The frames or supports must be constructed with non-combustible materials and should be square and level to 1/16" per linear foot (5mm per linear meter) in any direction.
- 3 - Frame or supports must be high enough to prevent any form of moisture from entering unit. Recommended minimum frame height is 14" (356mm).
- 4 - Duct must be attached to the roof mounting frame and not to the unit. Supply and return plenums must be installed before setting the unit.

- 5 - Units require support along all four sides of unit base. Supports must be constructed of steel or suitably treated wood materials.

NOTE - When installing a unit on a combustible surface for downflow discharge applications, an LARMF18/36 roof mounting frame is required.

B-Horizontal Discharge Applications

- 1 - Units installed in horizontal airflow applications must use an LARMFH18/24 horizontal roof mounting frame. The supply air duct connects to the horizontal supply air opening on the LARMFH18/24. The return air duct connects to the unit horizontal return air opening. Refer to unit dimensions.
- 2 - Specified installation clearances must be maintained when installing units. Refer to FIGURE 1.
- 3 - Top of support slab should be approximately 4" (102mm) above the finished grade and located so no run-off water from higher ground can collect around the unit.
- 4 - Units require support along all four sides of unit base. Supports must be constructed of steel or suitably treated wood materials.

Duct Connection

All exterior ducts, joints and openings in roof or building walls must be insulated and weather-proofed with flashing and sealing compounds in accordance with applicable codes. Any duct passing through an unconditioned space must be insulated.

CAUTION

In downflow applications, do not drill or punch holes in base of unit. Leaking in roof may occur if unit base is punctured.

Rigging for Lifting

Rig unit for lifting by attaching four cables to holes in unit base rail. See FIGURE 2.

- 1 - Detach wooden base protection before rigging.
- 2 - Connect rigging to the unit base using both holes in each corner.
- 3 - All panels must be in place for rigging.
- 4 - Place field-provided H-style pick in place just above top edge of unit. Frame must be of adequate strength and length. (H-style pick prevents damage to unit.)

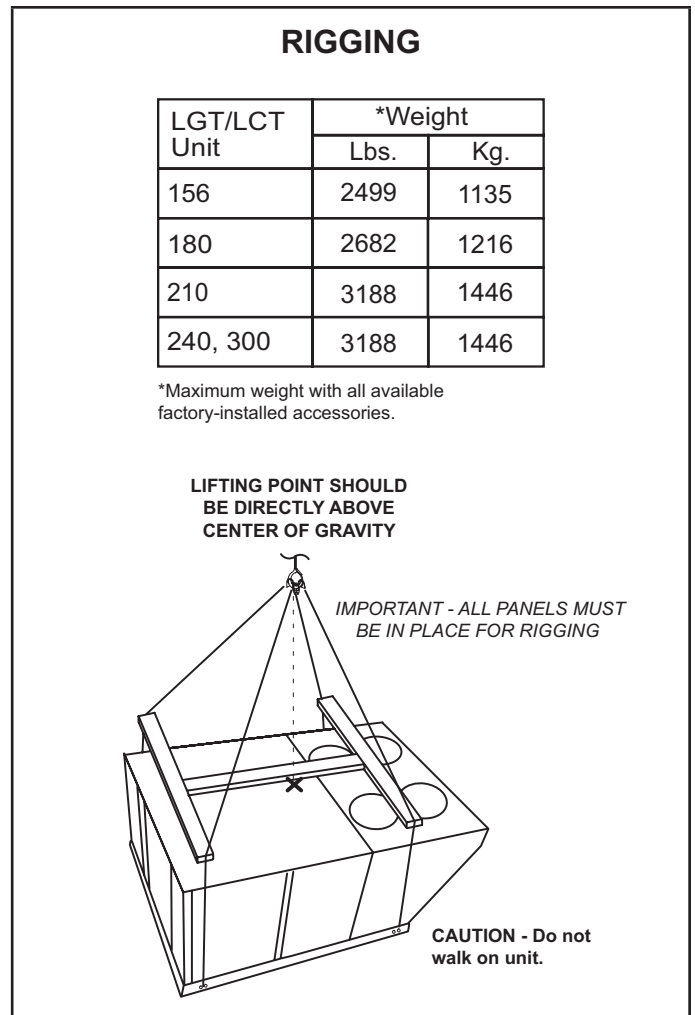

FIGURE 2

Condensate Drains

Remove cap and make drain connection to the 1" N.P.T. drain coupling provided on unit. A trap must be installed between drain connection and an open vent for proper condensate removal. See FIGURE 3. It is sometimes acceptable to drain condensate onto the roof or grade; however, a tee should be fitted to the trap to direct condensate downward. The condensate line must be vented. Check local codes concerning condensate disposal. Refer to page 4, page 5 and page 6 for condensate drain location.

NOTE - The drain pan is made with a glass reinforced engineered plastic capable of withstanding typical joint torque but can be damaged with excessive force. Tighten pipe nipple hand tight and turn an additional quarter turn.

CONDENSATE DRAIN CONNECTION

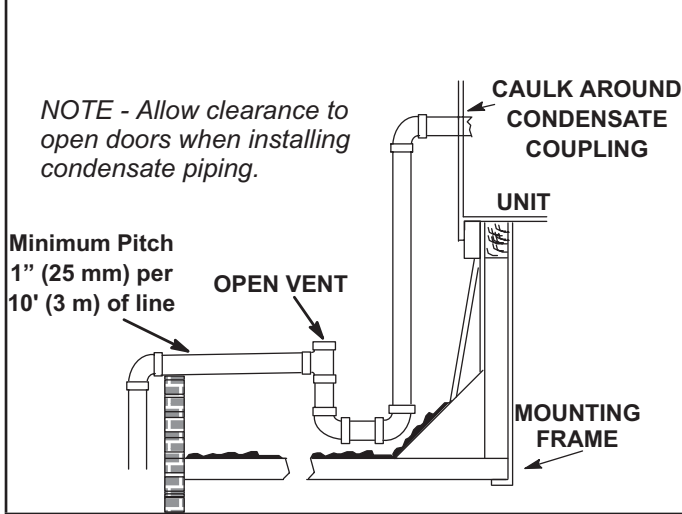

FIGURE 3

Connect Gas Piping

Before connecting piping, check with gas company or authorities having jurisdiction for local code requirements. When installing gas supply piping, length of run from gas meter must be considered in determining pipe size for 0.5" w.c. (.12kPa) maximum pressure drop. Do not use supply pipe smaller than unit gas connection. For natural gas units, operating pressure at the unit gas connection must be a minimum of 4.7" w.c. (1.17kPa) and a maximum of 10.5" (2.60kPa) w.c. For LP/propane gas units, operating pressure at the unit gas connection must be a minimum of 11" w.c. (2.74kPa) and a maximum of 13.5" w.c. (3.36kPa).

When making piping connections a drip leg should be installed on vertical pipe runs to serve as a trap for sediment or condensate. A 1/8" N.P.T. plugged tap is located on gas valve for test gauge connection. Refer to Heating Start-Up section for tap location.

A manual main shut-off valve must be installed external to the unit when local codes require the installation of such a valve.

Install a ground joint union between the gas control manifold and the main manual shut-off valve. See FIGURE 4 for gas supply piping entering outside the unit. See FIGURE 5 for gas supply entering through bottom of unit.

Compounds used on threaded joints of gas piping shall be resistant to the action of liquefied petroleum gases.

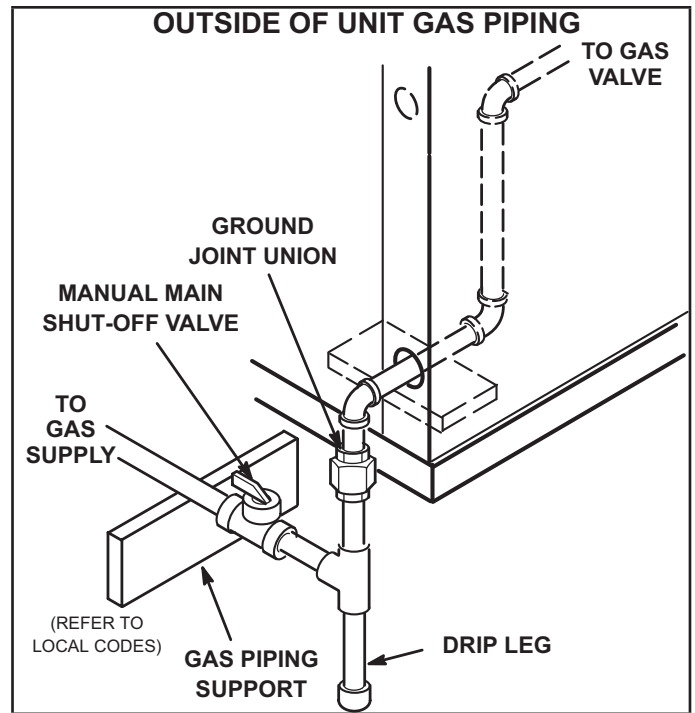

FIGURE 4

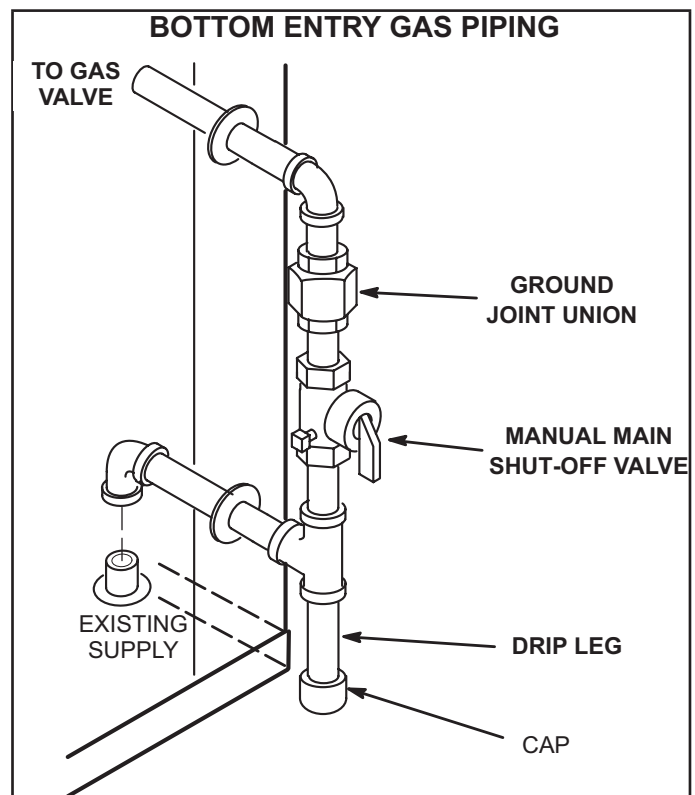

FIGURE 5

Pressure Test Gas Piping

When pressure testing gas lines, the gas valve must be disconnected and isolated. Gas valves can be damaged if subjected to more than 0.5 psig (3.48kPa). See FIGURE 6.

NOTE - Codes may require that manual main shut-off valve and union (furnished by installer) be installed in gas line external to unit. Union must be of the ground joint type.

After all connections have been made, check all piping connections for gas leaks. Also check existing unit gas connections up to the gas valve; loosening may occur during installation. Use a leak detection solution or other preferred means. Do not use matches candles or other sources of ignition to check for gas leaks.

NOTE - In case emergency shut down is required, turn off the main manual shut-off valve and disconnect main power to unit. These devices should be properly labeled by the installer.

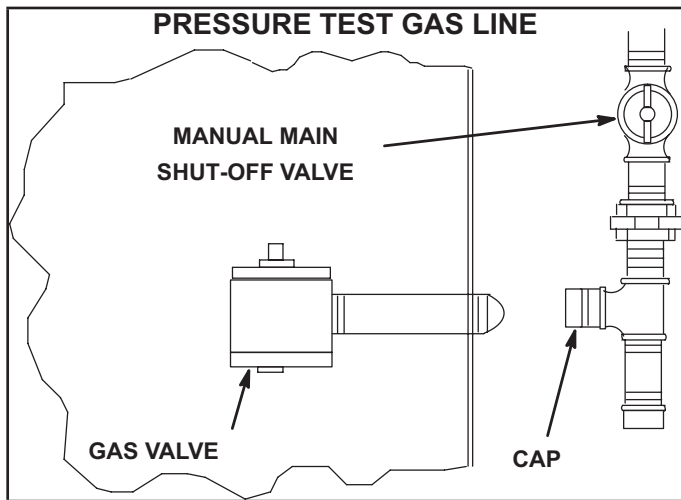

FIGURE 6

CAUTION

Some soaps used for leak detection are corrosive to certain metals. Carefully rinse piping thoroughly after leak test has been completed. Do not use matches, candles, flame or other sources of ignition to check for gas leaks.

WARNING



Danger of explosion. Can cause injury or product or property damage. Do not use matches, candles, flame or other sources of ignition to check for leaks.

Electrical Connections - Power Supply

A-Wiring

Route field wiring in conduit between bottom power entry and disconnect. See FIGURE 7. This does not supersede local codes or authorities having jurisdiction.

Do not apply power or close disconnect switch until installation is complete. Refer to start-up directions. Refer closely to unit wiring diagram.

Refer to unit nameplate for minimum circuit ampacity and maximum fuse size.

1 - Units are factory-wired for 240/460/575 volt supply. For 208V supply, remove the insulated terminal cover from the 208V terminal on the control transformer. Move the wire from the transformer 240V terminal to the 208V terminal. Place the insulated terminal cover on the unused 240V terminal.

2 - Route power through the bottom power entry area and connect to line side of unit disconnect, circuit breaker or terminal block. See unit wiring diagram.

3 - Units With Optional 120v GFCI Outlet

Route and connect separate 120v wiring to GFCI outlets which do not have factory-installed wiring. Route field wiring in conduit between bottom power entry and GFCI. See FIGURE 7.

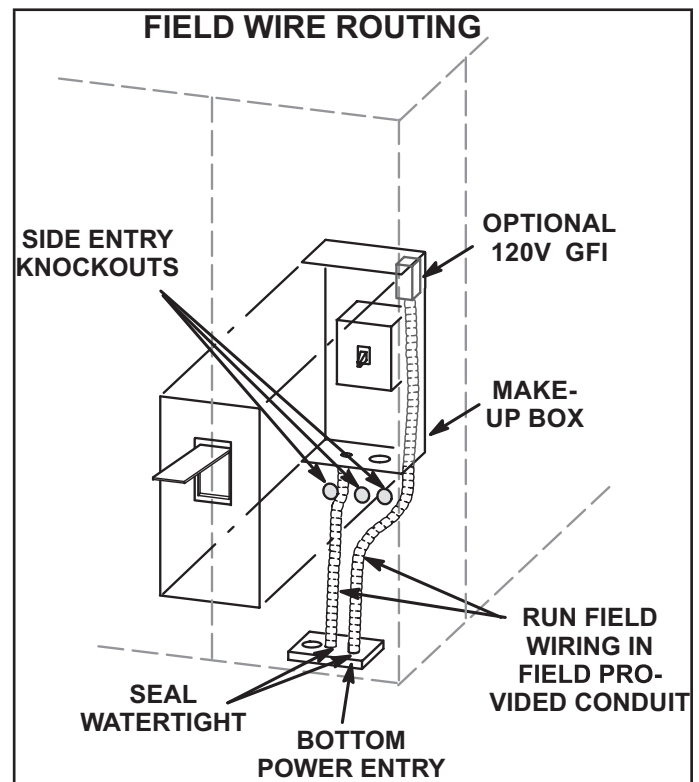

FIGURE 7

B-Unbalanced Three-Phase Voltage

Units equipped with an inverter (VFD) are designed to operate on balanced, three-phase power. Operating units on unbalanced three-phase power will reduce the reliability of all electrical components in the unit. Unbalanced power is a result of the power delivery system supplied by the local utility company.

Factory-installed inverters are sized to drive blower motors with an equivalent current rating using balanced three-phase power. When unbalanced three-phase power is supplied; the installer must replace the existing factory-installed inverter with an inverter that has a higher current rating to allow for the imbalance. Use TABLE 1 to determine the appropriate replacement inverter.

**TABLE 1
INVERTER UP-SIZING**

Factory-Installed Inverter HP	Replacement Inverter HP
2	5
3	7-1/2
5	10
7.5	15
10	20

Electrical Connections - Control Wiring

Connect either a thermostat, room/zone sensor, or direct digital controller; one of the three are required for unit function. Refer to the literature provided with each device and the following information.

NOTE - Optional wireless sensors are available for use with this unit.

A-Thermostat Location

Room thermostat mounts vertically on a standard 2" X 4" handy box or on any non-conductive flat surface.

Locate thermostat approximately 5 feet (1524mm) above the floor in an area with good air circulation at average temperature. Avoid locating the room thermostat where it might be affected by:

- drafts or dead spots behind doors and in corners
- hot or cold air from ducts
- radiant heat from sun or appliances
- concealed pipes and chimneys

B-Wire Routing

Route thermostat cable or wires from subbase through knockout provided in unit. Use 18 AWG wire for all applications using remotely installed electro-mechanical and electronic thermostats.

On hot gas reheat units, route wires from RH sensor or remote switch through knockout provided in unit. For sensor installations, use 22AWG stranded, two twisted pairs, individually shielded, 100% aluminum shield with drain wire and Teflon jacket.

IMPORTANT - Unless field thermostat wires are rated for maximum unit voltage, they must be routed away from line voltage wiring.

C-Wire Connections

The Unit Controller will operate the unit from a thermostat or zone sensor based on the System Mode. The default System Mode is the thermostat mode. Refer to the Unit Controller Setup Guide to change the System Mode. Use the mobile service app menu and select:

SETTINGS > INSTALL

NOTE - Unit Controller is capable of up to four stages of cooling in network control mode.

1 - Default Thermostat Mode

The Unit Controller will operate two stages of heating and cooling based on thermostat demands. Install thermostat assembly in accordance with instructions provided with thermostat. See FIGURE 8 for field wiring and refer to wiring diagrams on unit.

IMPORTANT - Terminal connections at the wall plate or subbase must be made securely. Loose control wire connections may result in intermittent operation.

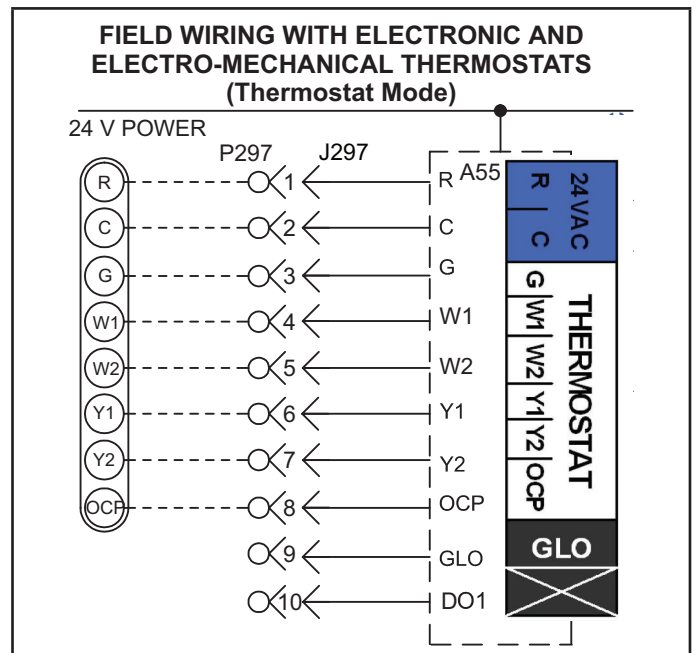

FIGURE 8

2 - Zone Sensor Mode

The Unit Controller will operate heating and cooling based on the Unit Controller internal setpoints and the temperature from the A2 zone sensor. An optional Network Control Panel (NCP) can also be used to provide setpoints. A thermostat or return air sensor can be used as a back-up mode. Make zone sensor wiring connections as shown in FIGURE 9.

NOTE - Install sensor and make communication wiring connections as shown in literature provided with sensor.

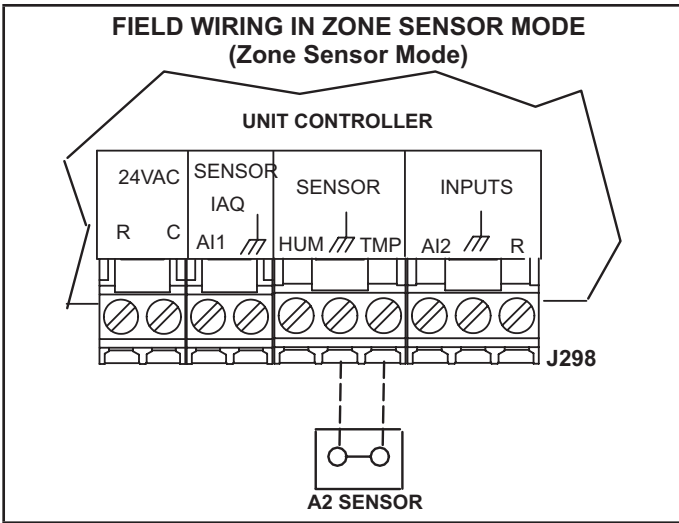

FIGURE 9

D-Hot Gas Reheat Units Only

- 1 - Install humidity sensor in accordance with instructions provided with sensor. A DDC input may be used to initiate dehumidification instead of a sensor.
- 2 - Make wiring connections as shown in FIGURE 8 for Thermostat Mode and FIGURE 9 for Zone Sensor Mode. In addition, connect either a humidity sensor or a dehumidification input. See FIGURE 10 or FIGURE 11 for humidity sensor wiring and FIGURE 12 for dehumidification input wiring.

Humidity Sensor Cable Applications

Wire runs of 50 feet (mm) or less:

Use two separate shielded cables containing 20AWG minimum, twisted pair conductors with overall shield. Belden type 8762 or 88760 (plenum) or equivalent. Connect both cable shield drain wires to TB1-7 as shown in FIGURE 10.

Wire runs of 150 feet (mm) or less:

Use two separate shielded cables containing 18AWG minimum, twisted pair conductors with overall shield. Belden type 8760 or 88760 (plenum) or equivalent. Connect both cable shield drain wires to TB1-7 as shown in FIGURE 10.

Wire runs over 150 feet (mm):

Use a local, isolated 24VAC transformer such as Lennox cat #18M13 (20VA minimum) to supply power to RH sensor as shown in FIGURE 11. Use two shielded cables containing 20AWG minimum, twisted pair conductors with overall shield. Belden type 8762 or 88760 (plenum) or equivalent.

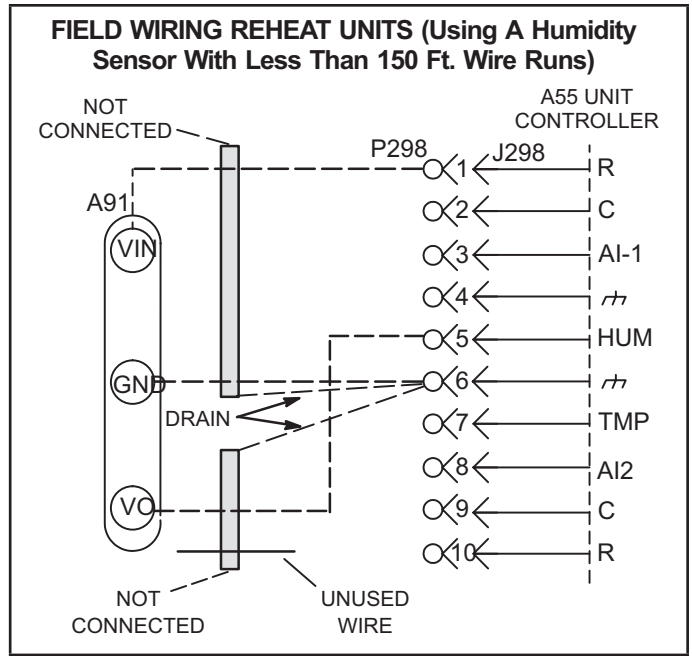

FIGURE 10

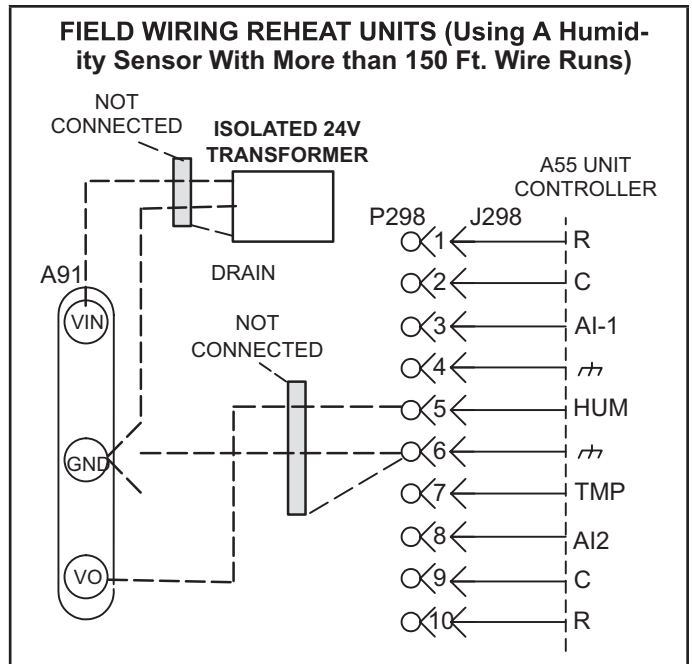

FIGURE 11

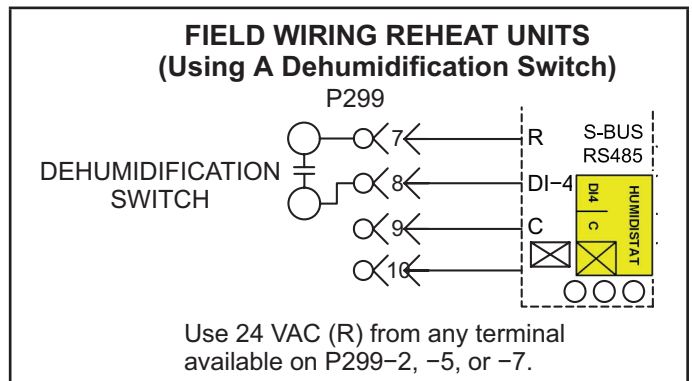

FIGURE 12

Mobile Service App

Setup and configure each rooftop unit using the mobile service app (Android or iOS devices supported).

A-Mobile Device Requirements

- Bluetooth connection.
- Android hardware requires 2GB RAM and a 2Ghz core processor. Tablets are supported.
- The app is available for both iOS 11.0 or higher (App Store) and Android 9.0 or higher (Google Play).

B-Download the App

Use your mobile device to scan the QR code from the cover page and download the mobile service app to your mobile device.

C-Pair the App to the Unit Controller

- 1 - Apply power to the unit and wait until the Unit Controller has booted-up (approximately two minutes).
- 2 - Press and hold the pair button for five seconds. See FIGURE 14.
- 3 - The unit (or list of units) will appear; select the appropriate unit. When the app code matches the four-character code on the Unit Controller display, the unit is paired (within 10 seconds). Note the following:
 - The app will list the units by signal strength; the RTU name will be displayed.
 - Once paired, the RTU name, model number, serial number and firmware version will be displayed.

Please refer to the manufacturer's website for additional technical information and self-help support.

D-App Menus

See FIGURE 13 for the menu overview. Follow the app prompts in the Install, Network Integration, and Test and Balance menus. Verify the app is setup properly for the unit application (including the date and time). Refer to FIGURE 15, FIGURE 16, and FIGURE 17.

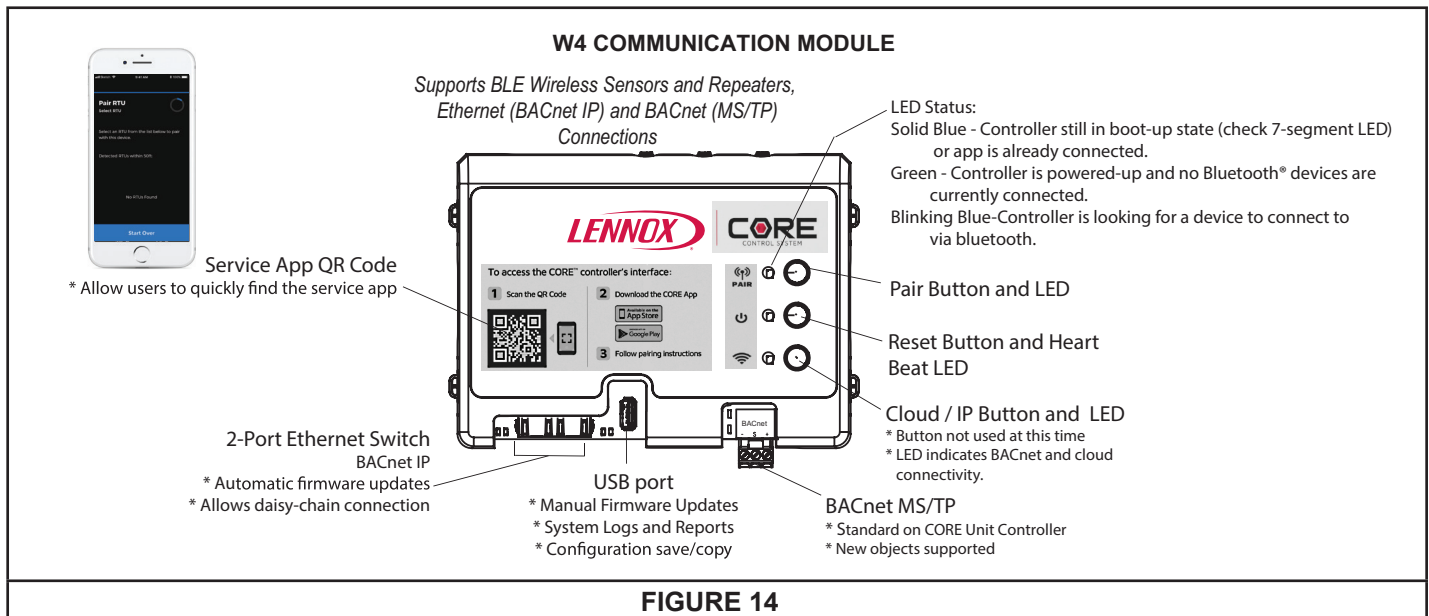
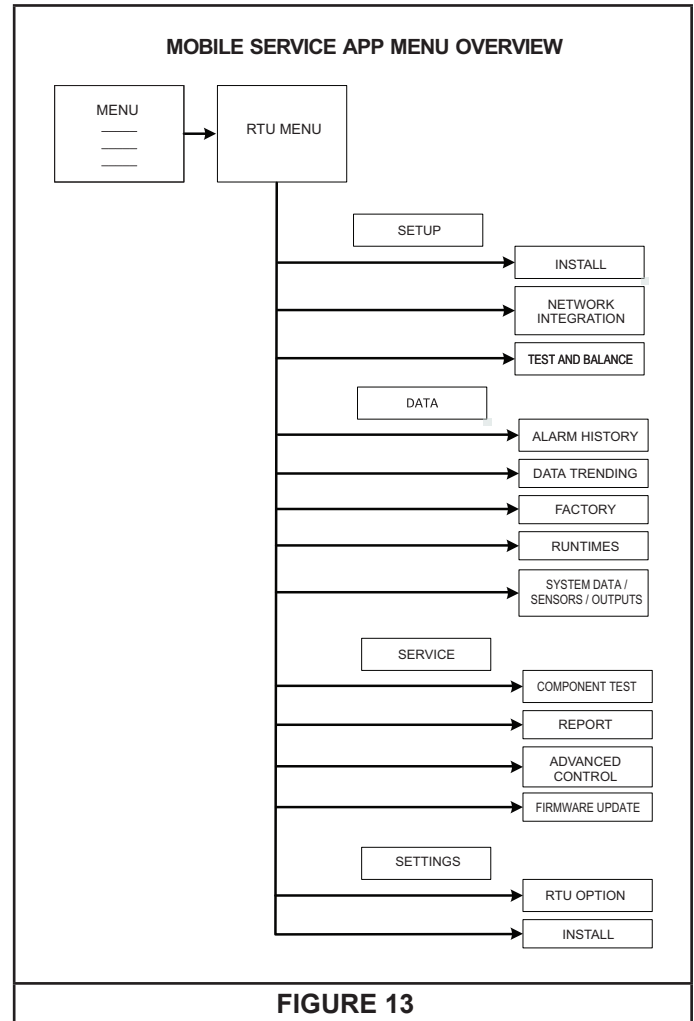

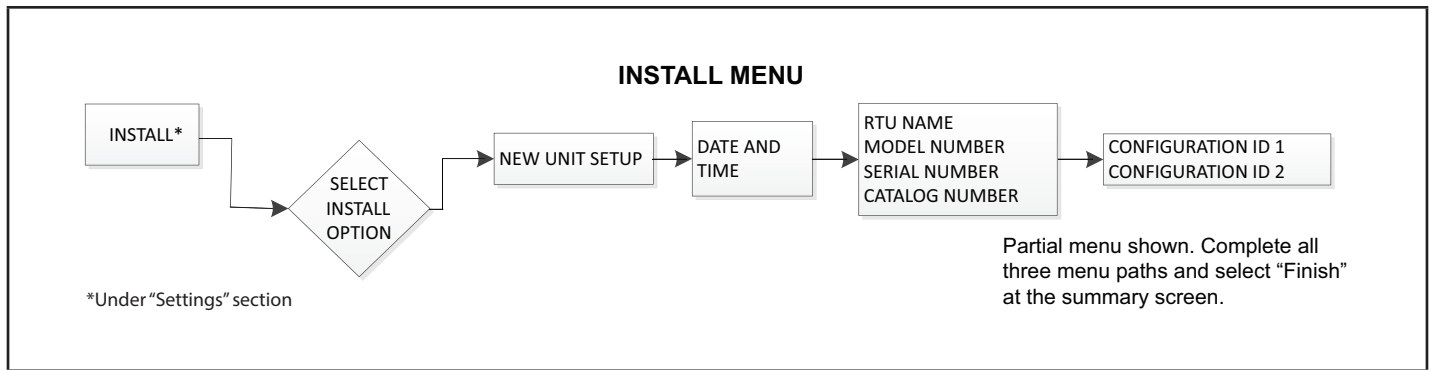

FIGURE 15

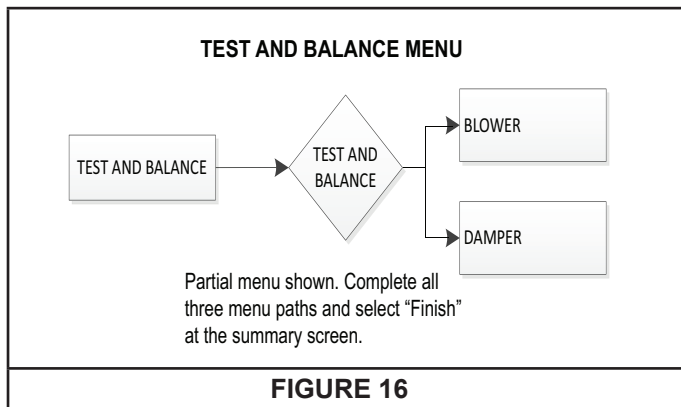

FIGURE 16

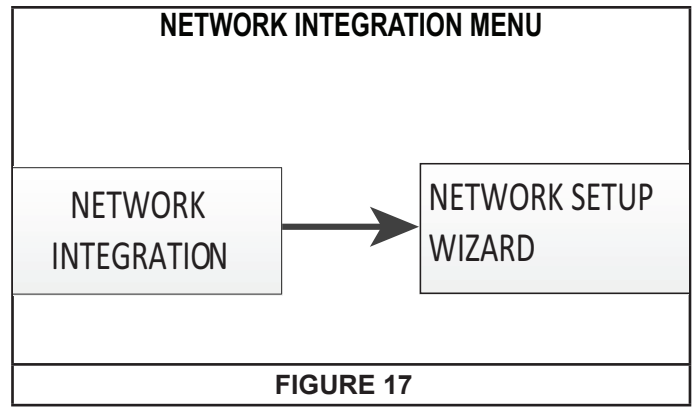

FIGURE 17

E-Unit Controller Components

See FIGURE 18 for Unit Controller components. See FIGURE 19 and TABLE 2 for pushbutton and LED functions.

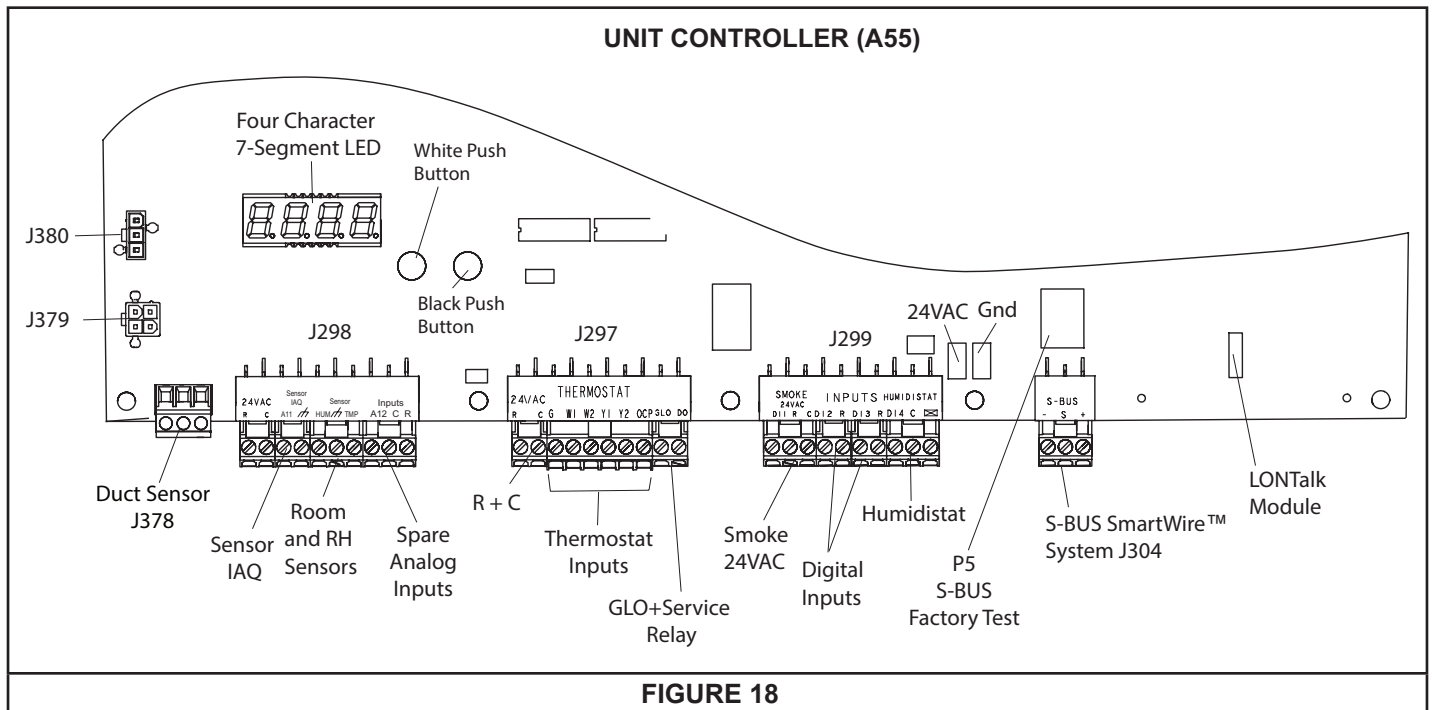

FIGURE 18

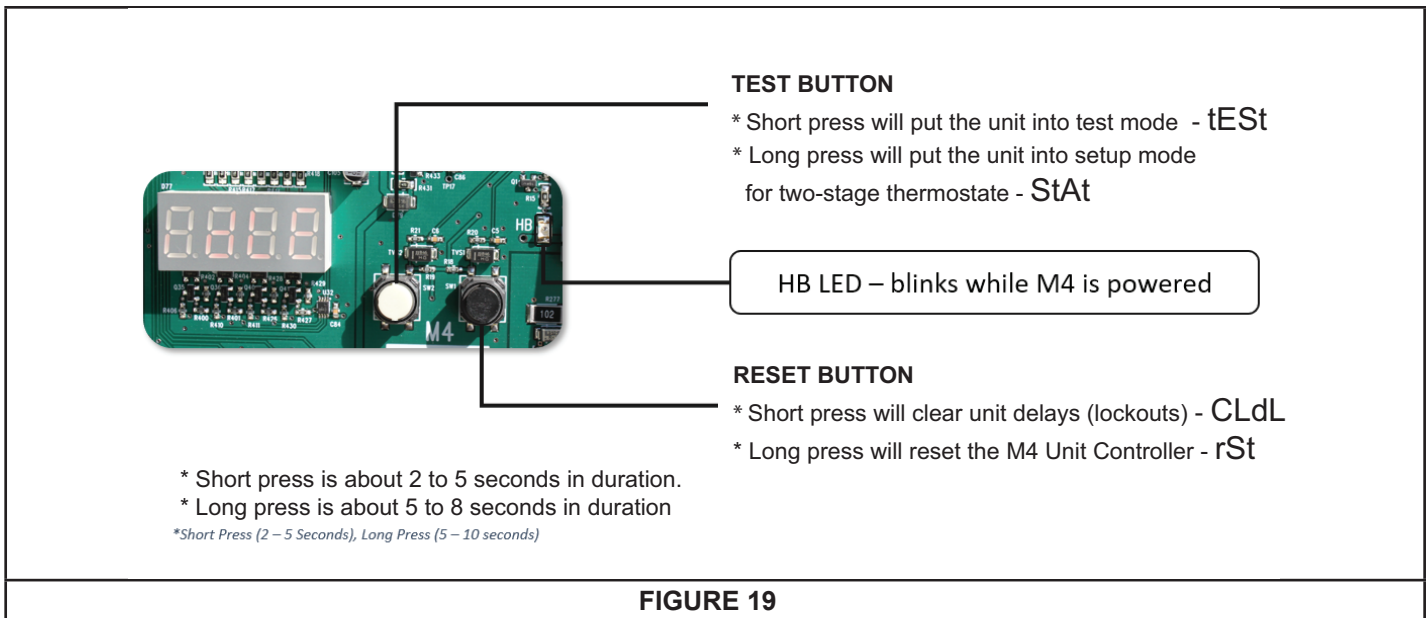

FIGURE 19

TABLE 2

UNIT CONTROLLER PUSHBUTTON CODES

Code	Cause	Action
CLdL	Black Button: Short Press	Clear Delays
rSt	Black Button: Long Press	Reset
tEst	White Button: Short Press	TSTAT Test
StAt	White Button: Long Press (In Pre-Install state)	TSTAT Override
tEst	White Button: Long Press (NOT in Pre-Install State)	TSTAT Test

Short Press : 2 to 5 seconds.

Long Press : 5 to 8 seconds.

Blower Operation and Adjustments

Supply Air Staged Units - The blower rotation will always be correct on units equipped with an inverter. Checking blower rotation is not a valid method of determining voltage phasing for incoming power.

Supply Air Staged Units and Units Equipped With Optional Voltage or Phase Detection - The Unit Controller checks the incoming power during start-up. If the voltage or phase is incorrect, the Unit Controller will display an alarm and the unit will not start.

A-Blower Operation

Refer to the Unit Controller Setup Guide to energize blower. Use this mobile service app menu:

SERVICE > TEST > BLOWER

Instructions provided with the thermostat may also be used to initiate blower only (G) demand. Unit will cycle on thermostat demand. The following steps apply to applications using a typical electro-mechanical thermostat.

- 1 - Blower operation is manually set at the thermostat subbase fan switch. With fan switch in **ON** position, blowers will operate continuously.
- 2 - With fan switch in **AUTO** position, the blowers will cycle with demand. Blowers and entire unit will be off when system switch is in **OFF** position.

IMPORTANT

Three Phase Scroll Compressor Voltage Phasing

Three phase scroll compressors must be phased sequentially to ensure correct compressor and blower* rotation and operation. Compressor and blower are wired in phase at the factory. Power wires are color-coded as follows: line 1-red, line 2-yellow, line 3-blue.

- 1- Observe suction and discharge pressures and blower* rotation on unit start-up.
- 2- Suction pressure must drop, discharge pressure must rise, and blower* rotation must match rotation marking.

If pressure differential is not observed or blower* rotation is not correct:

- 3- Disconnect all remote electrical power supplies.
- 4- Reverse any two field-installed wires connected to the line side of S48 disconnect or TB13 terminal strip. Do not reverse wires at blower contactor.
- 5- Make sure the connections are tight.

Discharge and suction pressures should operate at their normal start-up ranges.

*Supply air VFD motors should rotate in the correct direction; verify scroll compressor rotation separately. Contact technical support if the VFD blower is rotating incorrectly.

WARNING

- 1- Make sure that unit is installed in accordance with the installation instructions and applicable codes.
- 2- Inspect all electrical wiring, both field and factory-installed, for loose connections. Tighten as required.
- 3- Check to ensure that refrigerant lines do not rub against the cabinet or against other refrigerant lines.
- 4- Check voltage at disconnect switch. Voltage must be within range listed on nameplate. If not, consult power company and have voltage condition corrected before starting unit.
- 5- Make sure filters are new and in place before start-up.

B-Blower Access

- 1 - Disconnect jack/plug connector to blower motor. Also disconnect jack/plug connector heating limit switches on gas units.
- 2 - Remove screws on either side of blower assembly sliding base. See FIGURE 21.
- 3 - Pull base toward outside of unit.

C-Determining Unit CFM

IMPORTANT - Multi-staged supply air units are factory-set to run the blower at full speed when there is a blower (G) demand without a heating or cooling demand. Refer to the field-provided, design specified CFM for all modes of operation. Use the following procedure to adjust motor pulley to deliver the highest CFM called for in the design spec. See Inverter Start-Up section to set blower CFM for all modes once the motor pulley is set.

Variable Air Volume Units - Refer to the Variable Air Volume Start-Up section.

- 1 - The following measurements must be made with a dry indoor coil. Run blower (G demand) without a cooling demand. Measure the indoor blower shaft RPM. Air filters must be in place when measurements are taken.
- 2 - With all access panels in place, measure static pressure external to unit (from supply to return). Blower performance data is based on static pressure readings taken in locations shown in FIGURE 20.

NOTE - Static pressure readings can vary if not taken where shown.

- 3 - Referring to page 22, use static pressure and RPM readings to determine unit CFM. Use page 23 when installing units with any of the optional accessories listed.
- 4 - The blower RPM can be adjusted at the motor pulley. Loosen Allen screw and turn adjustable pulley clockwise to increase CFM. Turn counterclockwise to decrease CFM. See FIGURE 21. Do not exceed minimum and maximum number of pulley turns as shown in TABLE 3.

TABLE 3
MINIMUM AND MAXIMUM PULLEY ADJUSTMENT

Belt	Min. Turns Open	Max. Turns Open
A Section	No minimum	5
B Section	1*	6

*No minimum number of turns open when B belt is used on pulleys 6" O.D. or larger.

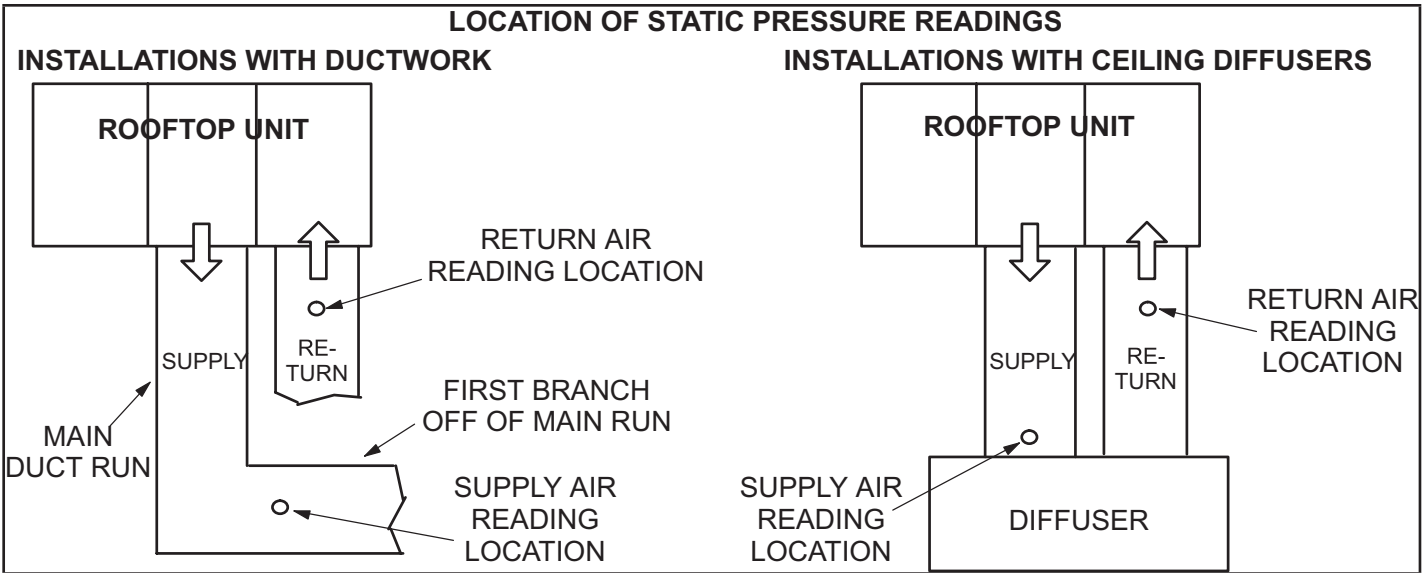

FIGURE 20

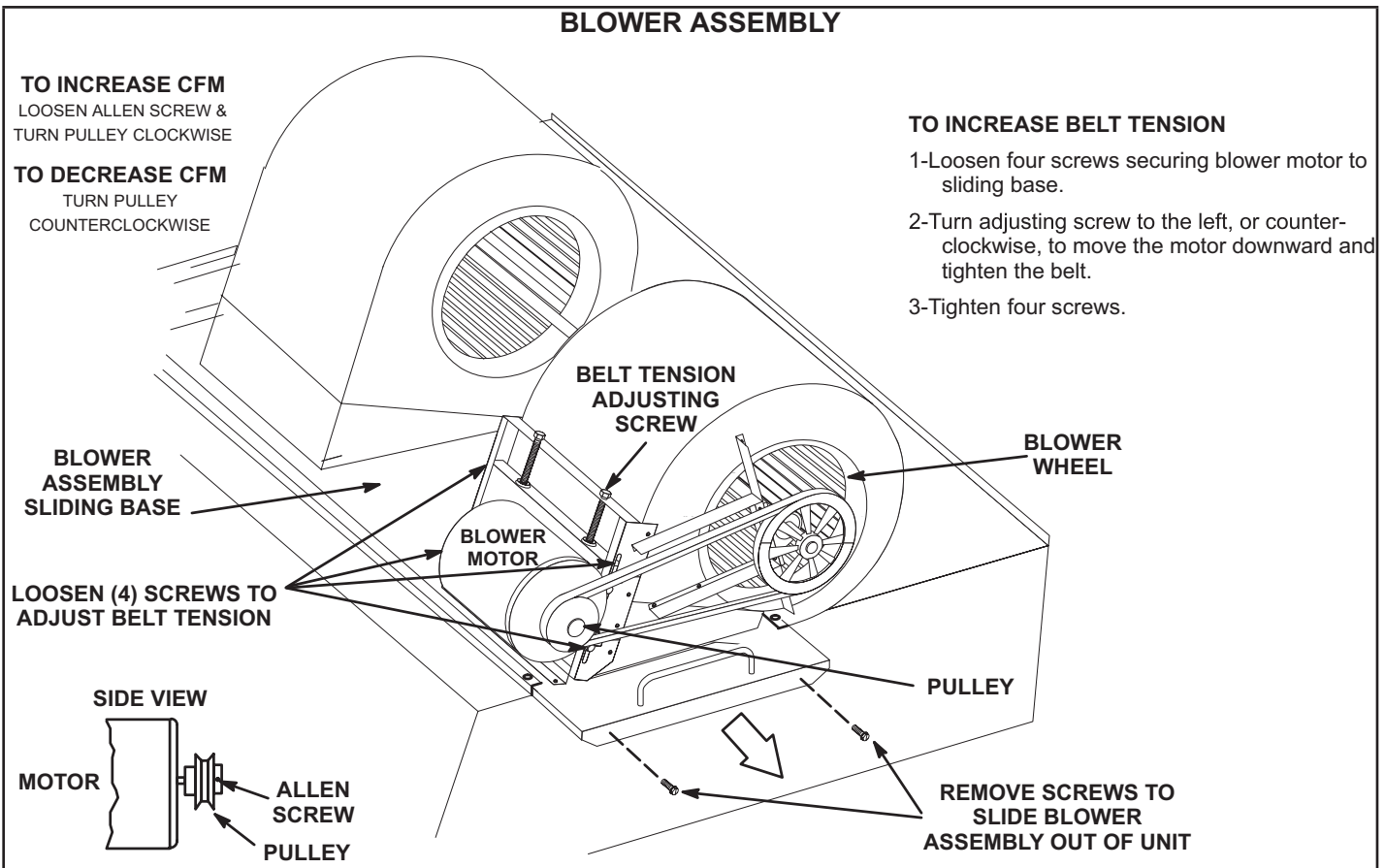

FIGURE 21

D-Blower Belt Adjustment

Maximum life and wear can be obtained from belts only if proper pulley alignment and belt tension are maintained. Tension new belts after a 24-48 hour period of operation. This will allow belt to stretch and seat into pulley grooves. Make sure blower and motor pulley are aligned. See FIGURE 22.

- 1 - Loosen four screws securing blower motor to sliding base. See FIGURE 21.
- 2 - To increase belt tension -
Turn belt tension adjusting screw to the left, or counterclockwise, to tighten the belt. This increases the distance between the blower motor and the blower housing.
To loosen belt tension -
Turn the adjusting screw to the right, or clockwise to loosen belt tension.
- 3 - Tighten four screws securing blower motor to sliding base once adjustments have been made.

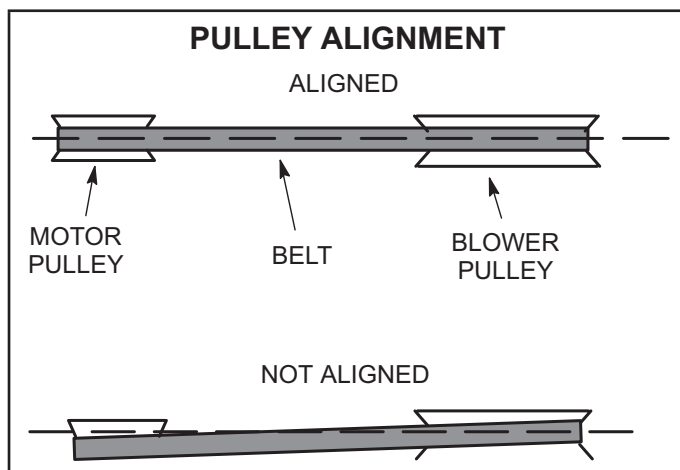

FIGURE 22

E-Check Belt Tension

Overtensioning belts shortens belt and bearing life. Check belt tension as follows:

- 1 - Measure span length X. See FIGURE 23.

- 2 - Apply perpendicular force to center of span (X) with enough pressure to deflect belt 1/64" for every inch of span length or 1.5mm per 100mm of span length.
Example: Deflection distance of a 40" span would be 40/64" or 5/8".
Example: Deflection distance of a 400mm span would be 6mm.
- 3 - Measure belt deflection force. For a used belt, the deflection force should be 5 lbs. (35kPa). A new belt deflection force should be 7 lbs. (48kPa).

A force below these values indicates an undertensioned belt. A force above these values indicates an overtensioned belt.

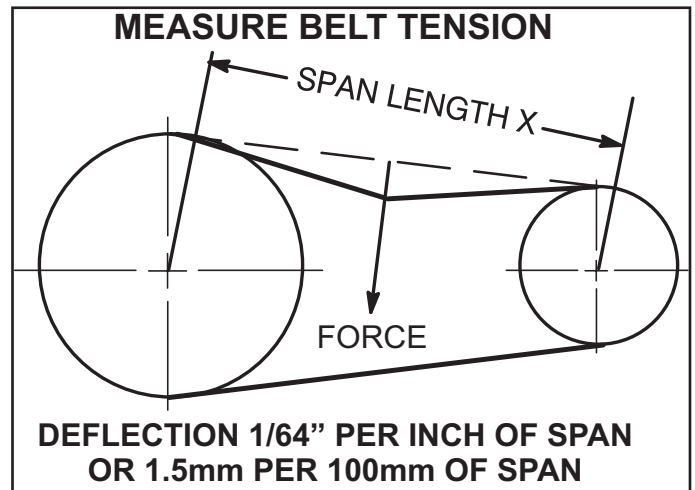

FIGURE 23

F-Field-Furnished Blower Drives

For field-furnished blower drives, use page 22 to determine BHP and RPM required. Reference page 24 to determine the manufacturer's model number.

G-Minimum Airflow For Optional Electric Heat

Electric Heat kW	Minimum CFM
15	5200
30	5200
45	5200
60	5200
90	6000

BLOWER DATA

BLOWER TABLE INCLUDES RESISTANCE FOR BASE UNIT ONLY WITH DRY INDOOR COIL & AIR FILTERS IN PLACE.

FOR ALL UNITS ADD: 1 - Wet indoor coil air resistance of selected unit. 2 - Any factory installed options air resistance (heat section, economizer, etc.) 3 - Any field installed accessories air resistance (heat section, duct resistance, diffuser, etc.).

Then determine from blower table blower motor output and drive required.

See page 23 for wet coil, option/accessory air resistance data, and factory installed drive kit specifications.

MINIMUM AIR VOLUME REQUIRED FOR DIFFERENT GAS HEAT SIZES:

Low, Standard and Medium Heat - 4500 cfm minimum; High Heat - 5125 cfm

MINIMUM AIR VOLUME REQUIRED FOR USE WITH OPTIONAL ELECTRIC HEAT:

LCT units with 15-60KW electric heat require 5200 cfm minimum air; units with 90KW require 6000 cm minimum air.

Air Volume cfm	TOTAL STATIC PRESSURE - Inches Water Gauge (Pa)																																																																																																																																																																																																																																																																																																																																																																																																																																																																																																																																																																																																																																																																																																																																																																																																																																																																																																																																																																																																																																																																																																																																																																																														
	0.20		0.40		0.60		0.80		1.00		1.20		1.40		1.60		1.80		2.00		2.20		2.40		2.60																																																																																																																																																																																																																																																																																																																																																																																																																																																																																																																																																																																																																																																																																																																																																																																																																																																																																																																																																																																																																																																																																																																																																																						
	RPM	BHP	RPM	BHP	RPM	BHP	RPM	BHP	RPM	BHP	RPM	BHP	RPM	BHP	RPM	BHP	RPM	BHP	RPM	BHP	RPM	BHP	RPM	BHP	RPM	BHP	RPM	BHP																																																																																																																																																																																																																																																																																																																																																																																																																																																																																																																																																																																																																																																																																																																																																																																																																																																																																																																																																																																																																																																																																																																																																																			
2750	385	0.30	505	0.50	600	0.70	680	0.90	755	1.10	820	1.30	885	1.50	950	1.70	1005	1.90	1060	2.10	1115	2.30	1170	2.50	1225	2.70	1280	2.90	1335	3.10	1390	3.30	1445	3.50	1500	3.70	1555	3.90	1610	4.10	1665	4.30	1720	4.50	1775	4.70	1830	4.90	1885	5.10	1940	5.30	1995	5.50	2050	5.70	2105	5.90	2160	6.10	2215	6.30	2270	6.50	2325	6.70	2380	6.90	2435	7.10	2490	7.30	2545	7.50	2600	7.70	2655	7.90	2710	8.10	2765	8.30	2820	8.50	2875	8.70	2930	8.90	2985	9.10	3040	9.30	3095	9.50	3150	9.70	3205	9.90	3260	10.10	3315	10.30	3370	10.50	3425	10.70	3480	10.90	3535	11.10	3590	11.30	3645	11.50	3700	11.70	3755	11.90	3810	12.10	3865	12.30	3920	12.50	3975	12.70	4030	12.90	4085	13.10	4140	13.30	4195	13.50	4250	13.70	4305	13.90	4360	14.10	4415	14.30	4470	14.50	4525	14.70	4580	14.90	4635	15.10	4690	15.30	4745	15.50	4800	15.70	4855	15.90	4910	16.10	4965	16.30	5020	16.50	5075	16.70	5130	16.90	5185	17.10	5240	17.30	5295	17.50	5350	17.70	5405	17.90	5460	18.10	5515	18.30	5570	18.50	5625	18.70	5680	18.90	5735	19.10	5790	19.30	5845	19.50	5900	19.70	5955	19.90	6010	20.10	6065	20.30	6120	20.50	6175	20.70	6230	20.90	6285	21.10	6340	21.30	6395	21.50	6450	21.70	6505	21.90	6560	22.10	6615	22.30	6670	22.50	6725	22.70	6780	22.90	6835	23.10	6890	23.30	6945	23.50	7000	23.70	7055	23.90	7110	24.10	7165	24.30	7220	24.50	7275	24.70	7330	24.90	7385	25.10	7440	25.30	7495	25.50	7550	25.70	7605	25.90	7660	26.10	7715	26.30	7770	26.50	7825	26.70	7880	26.90	7935	27.10	7990	27.30	8045	27.50	8100	27.70	8155	27.90	8210	28.10	8265	28.30	8320	28.50	8375	28.70	8430	28.90	8485	29.10	8540	29.30	8595	29.50	8650	29.70	8705	29.90	8760	30.10	8815	30.30	8870	30.50	8925	30.70	8980	30.90	9035	31.10	9090	31.30	9145	31.50	9200	31.70	9255	31.90	9310	32.10	9365	32.30	9420	32.50	9475	32.70	9530	32.90	9585	33.10	9640	33.30	9695	33.50	9750	33.70	9805	33.90	9860	34.10	9915	34.30	9970	34.50	10025	34.70	10080	34.90	10135	35.10	10190	35.30	10245	35.50	10300	35.70	10355	35.90	10410	36.10	10465	36.30	10520	36.50	10575	36.70	10630	36.90	10685	37.10	10740	37.30	10795	37.50	10850	37.70	10905	37.90	10960	38.10	11015	38.30	11070	38.50	11125	38.70	11180	38.90	11235	39.10	11290	39.30	11345	39.50	11400	39.70	11455	39.90	11510	40.10	11565	40.30	11620	40.50	11675	40.70	11730	40.90	11785	41.10	11840	41.30	11895	41.50	11950	41.70	12005	41.90	12060	42.10	12115	42.30	12170	42.50	12225	42.70	12280	42.90	12335	43.10	12390	43.30	12445	43.50	12500	43.70	12555	43.90	12610	44.10	12665	44.30	12720	44.50	12775	44.70	12830	44.90	12885	45.10	12940	45.30	12995	45.50	13050	45.70	13105	45.90	13160	46.10	13215	46.30	13270	46.50	13325	46.70	13380	46.90	13435	47.10	13490	47.30	13545	47.50	13600	47.70	13655	47.90	13710	48.10	13765	48.30	13820	48.50	13875	48.70	13930	48.90	13985	49.10	14040	49.30	14095	49.50	14150	49.70	14205	49.90	14260	50.10	14315	50.30	14370	50.50	14425	50.70	14480	50.90	14535	51.10	14590	51.30	14645	51.50	14700	51.70	14755	51.90	14810	52.10	14865	52.30	14920	52.50	14975	52.70	15030	52.90	15085	53.10	15140	53.30	15195	53.50	15250	53.70	15305	53.90	15360	54.10	15415	54.30	15470	54.50	15525	54.70	15580	54.90	15635	55.10	15690	55.30	15745	55.50	15800	55.70	15855	55.90	15910	56.10	15965	56.30	16020	56.50	16075	56.70	16130	56.90	16185	57.10	16240	57.30	16295	57.50	16350	57.70	16405	57.90	16460	58.10	16515	58.30	16570	58.50	16625	58.70	16680	58.90	16735	59.10	16790	59.30	16845	59.50	16900	59.70	16955	59.90	17010	60.10	17065	60.30	17120	60.50	17175	60.70	17230	60.90	17285	61.10	17340	61.30	17395	61.50	17450	61.70	17505	61.90	17560	62.10	17615	62.30	17670	62.50	17725	62.70	17780	62.90	17835	63.10	17890	63.30	17945	63.50	18000	63.70	18055	63.90	18110	64.10	18165	64.30	18220	64.50	18275	64.70	18330	64.90	18385	65.10	18440	65.30	18495	65.50	18550	65.70	18605	65.90	18660	66.10	18715	66.30	18770	66.50	18825	66.70	18880	66.90	18935	67.10	18990	67.30	19045	67.50	19100	67.70	19155	67.90	19210	68.10	19265	68.30	19320	68.50	19375	68.70	19430	68.90	19485	69.10	19540	69.30	19595	69.50	19650	69.70	19705	69.90	19760	70.10	19815	70.30	19870	70.50	19925	70.70	19980	70.90	20035	71.10	20090	71.30	20145	71.50	20200	71.70	20255	71.90	20310	72.10	20365	72.30	20420	72.50	20475	72.70	20530	72.90	20585	73.10	20640	73.30	20695	73.50	20750	73.70	20805	73.90	20860	74.10	20915	74.30	20970	74.50	21025	74.70	21080	74.90	21135	75.10	21190	75.30	21245	75.50	21300	75.70	21355	75.90	21410	76.10	21465	76.30	21520	76.50	21575	76.70	21630	76.90	21685	77.10	21740	77.30	21795	77.50	21850	77.70	21905	77.90	21960	78.10	22015	78.30	22070	78.50	22125	78.70	22180	78.90	22235	79.10	22290	79.30	22345	79.50	22400	79.70	22455	79.90	22510	80.10	22565	80.30	22620	80.50	22675	80.70	22730	80.90	22785	81.10	22840	81.30	22895	81.50	22950	81.70	23005	81.90	23060	82.10	23115	82.30	23170	82.50	23225	82.70	23280	82.90	23335	83.10	23390	83.30	23445	83.50	23500	83.70	23555	83.90	23610	84.10	23665	84.30	23720	84.50	23775	84.70	23830	84.90	23885	85.10	23940	85.30	23995	85.50	24050	85.70	24105	85.90	24160	86.10	24215	86.30	24270	86.50	24325	86.70	24380	86.90	24435	87.10	24490	87.30	24545	87.50	24600	87.70	24655	87.90	24710	88.10	24765	88.30	24820	88.50	24875	88.70	24930	88.90	24985	89.10	25040	89.30	25095	89.50	25150	89.70	25205	89.90	25260	90.10	25315	90.30	25370	90.50	25425	90.70	25480	90.90	25535	91.10	25590	91.30	25645	91.50	25700	91.70	25755	91.90	25810	92.10	25865	92.30	25920	92.50	25975	92.70	26030	92.90	26085	93.10	26140	93.30	26195	93.50	26250	93.70	26305	93.90	26360	94.10	26415	94.30	26470	94.50	26525	94.70	26580	94.90	26635	95.10	26690	95.30	26745	95.50	26800	95.70	26855	95.90	26910	96.10	26965	96.30	27020	96.50	27075	96.70	27130	96.90	27185	97.10	27240	97.30	27295	97.50	27350	97.70	27405	97.90	27460	98.10	27515	98.30	27570	98.50	27625	98.70	27680	98.90	27735	99.10	27790	99.30	27845	99.50	27900	99.70	27955	99.90	28010	100.10	28065	100.30	28120	100.50	28175	100.70	28230	100.90	28285	101.10	28340	101.30	28395	101.50	28450	101.70	28505	101.90	28560	102.10	28615	102.30	28670	102.50	28725	102.70	28780	102.90	28835	103.10	28890	103.30	28945	103.50	29000	103.70	29055	103.90	29110	104.10	29165	104.30	29220	104.50	29275	104.70	29330	104.90	29385	105.10	29440	105.30	29495	105.50	29550	105.70	29605	105.90	29660	106.10	29715	106.30	29770	106.50	29825	106.70	29880	106.90	29935	107.10	29990	107.30	30045	107.50	30100	107.70	30155	107.90	30210	108.10	30265	108.30	30320	108.50	30375	108.70	30430	108.90	30485	109.10	30540	109.30	30595	109.50	30650	109.70	30705	109.90	30760	110.10	30815	110.30	30870	110.50	30925	110.70	30980	110.90	31035	111.10	31090	111.30	31145	111.50	31200	111.70	31255	111.90	31310	112.10	31365	112.30	31420	112.50	31475	112.70	31530	112.90	31585	113.10	31640	113.30	31695	113.50	31750	113.70	31805	113.90	31860	114.10	31915	114.30	31970	114.50	32025	114.70	32080	114.90	32135	115.10	3219

BLOWER DATA

FACTORY INSTALLED BELT DRIVE KIT SPECIFICATIONS

Nominal hp	Maximum hp	Drive Kit Number	RPM Range
3	3.45	1	535 - 725
3	3.45	2	710 - 965
5	5.75	3	685 - 856
5	5.75	4	850 - 1045
5	5.75	5	945 - 1185
7.5	8.63	6	850 - 1045
7.5	8.63	7	945 - 1185
7.5	8.63	8	1045 - 1285
10	11.50	7	945 - 1185
10	11.50	10	1045 - 1285
10	11.50	11	1135 - 1330

NOTE - Using total air volume and system static pressure requirements determine from blower performance tables rpm and motor output required. Maximum usable output of motors furnished are shown. In Canada, nominal motor output is also maximum usable motor output. If motors of comparable output are used, be sure to keep within the service factor limitations outlined on the motor nameplate.

NOTE - All units are limited to a motor service factor of 1.0.

FACTORY INSTALLED OPTIONS/FIELD INSTALLED ACCESSORY AIR RESISTANCE

Air Volum cfm	Wet Indoor Coil		Reheat Coil	Gas Heat Exchanger			Electric Heat	Econo- mizer	Filters			Horizontal Roof Curb	
	156, 180	210, 240, 300		Low/ Std. Heat	Medium Heat	Heat Heat			MERV 8	MERV 13	MERV 16	156-240	300
	in. w.g.	in. w.g.	in. w.g.	in. w.g.	in. w.g.	in. w.g.	in. w.g.	in. w.g.	in. w.g.	in. w.g.	in. w.g.	in. w.g.	in. w.g.
2750	0.01	0.02	0.01	0.02	0.04	0.05	---	---	0.01	0.03	0.06	0.03	-
3000	0.01	0.02	0.01	0.03	0.04	0.05	---	---	0.01	0.03	0.06	0.04	-
3250	0.01	0.03	0.01	0.03	0.05	0.06	---	---	0.01	0.04	0.07	0.04	0.01
3500	0.01	0.03	0.02	0.03	0.05	0.06	---	---	0.01	0.04	0.08	0.05	0.01
3750	0.01	0.03	0.02	0.04	0.06	0.07	---	---	0.01	0.04	0.08	0.05	0.01
4000	0.02	0.04	0.02	0.04	0.06	0.07	---	---	0.01	0.04	0.09	0.06	0.02
4250	0.02	0.04	0.02	0.04	0.06	0.08	---	---	0.01	0.05	0.1	0.07	0.02
4500	0.02	0.05	0.02	0.05	0.07	0.09	---	---	0.01	0.05	0.1	0.07	0.02
4750	0.02	0.05	0.02	0.05	0.08	0.1	---	---	0.02	0.05	0.11	0.08	0.03
5000	0.02	0.05	0.02	0.05	0.09	0.11	---	---	0.02	0.06	0.12	0.08	0.03
5250	0.02	0.06	0.03	0.06	0.1	0.12	---	---	0.02	0.06	0.12	0.09	0.04
5500	0.02	0.07	0.03	0.06	0.1	0.13	---	---	0.02	0.06	0.13	0.1	0.04
5750	0.03	0.07	0.03	0.06	0.11	0.14	---	---	0.02	0.07	0.14	0.11	0.05
6000	0.03	0.08	0.03	0.07	0.12	0.15	0.01	---	0.03	0.07	0.14	0.11	0.06
6250	0.03	0.08	0.03	0.07	0.12	0.16	0.01	0.01	0.03	0.07	0.15	0.12	0.07
6500	0.03	0.09	0.04	0.08	0.13	0.17	0.01	0.02	0.03	0.08	0.16	0.13	0.08
6750	0.04	0.1	0.04	0.08	0.14	0.18	0.01	0.03	0.03	0.08	0.17	0.14	0.08
7000	0.04	0.1	0.04	0.09	0.15	0.19	0.01	0.04	0.04	0.08	0.17	0.15	0.09
7250	0.04	0.11	0.04	0.09	0.16	0.2	0.01	0.05	0.04	0.09	0.18	0.16	0.1
7500	0.05	0.12	0.05	0.1	0.17	0.21	0.01	0.06	0.04	0.09	0.19	0.17	0.11
8000	0.05	0.13	0.05	0.11	0.19	0.24	0.02	0.09	0.05	0.1	0.21	0.19	0.13
8500	0.06	0.15	0.05	0.12	0.2	0.26	0.02	0.11	0.05	0.1	0.22	0.21	0.15
9000	0.07	0.16	0.06	0.13	0.23	0.29	0.04	0.14	0.06	0.11	0.24	0.24	0.17
9500	0.08	0.18	0.07	0.14	0.25	0.32	0.05	0.16	0.07	0.12	0.25	0.26	0.19
10,000	0.08	0.2	0.07	0.16	0.27	0.35	0.06	0.19	0.07	0.12	0.27	0.29	0.21
10,500	0.09	0.22	0.08	0.17	0.3	0.38	0.09	0.22	0.08	0.13	0.29	0.31	0.24
11,000	0.11	0.24	0.08	0.18	0.31	0.4	0.11	0.25	0.09	0.14	0.3	0.34	0.27

**TABLE 4
MANUFACTURER'S NUMBERS**

Drive No.	H.P.	DRIVE COMPONENTS															
		RPM		ADJUSTABLE SHEAVE		FIXED SHEAVE		BELTS (STD.)		BELTS (WITH TENSIONER)		SPLIT BUSHING					
		Min	Max	Supplier No.	OEM Part No.	Supplier No.	OEM Part No.	Supplier No.	OEM Part No.	Supplier No.	OEM Part No.	Supplier No.	OEM Part No.				
1	2, 3	535	725	1VP40x7/8	79J0301	BK95 x 1-3/16	105617-02	BX59	59A5001	BX60	100245-10	N/A	N/A	N/A	N/A		
2	2, 3	710	965	1VP40x7/8	79J0301	BK72 x 1-3/16	105617-01	BX55	63K0501	BX57	78L5301	N/A	N/A	N/A	N/A		
3	5	685	865	1VP50x1-1/8	P-8-1977	BK100 x 1-3/16	105617-03	BX61	93J9801	5VX660	100245-20	N/A	N/A	N/A	N/A		
4	5	850	1045	1VP65x1-1/8	100239-03	BK110H	100788-06	BX65	100245-08	BX66	97J5901	H-1-3/16	105616-02	105616-02	105616-02		
5	5	945	1185	1VP60x1-1/8	41C1301	BK90H x 1-7/16	100788-04	BX61	93J9801	BX62	57A7701	H-1-3/16	105616-02	105616-02	105616-02		
6	7.5	850	1045	1VP65x1-3/8	78M7101	BK110H	100788-06	BX66	97J5901	BX67	100245-09	H-1-3/16	105616-02	105616-02	105616-02		
7	7.5 & 10	945	1185	1VP60x1-3/8	78L5501	BK90H x 1-7/16	100788-04	BX62	57A7701	BX64	97J5801	H-1-3/16	105616-02	105616-02	105616-02		
8	7.5	1045	1285	1VP65x1-3/8	78M7101	BK90H x 1-7/16	100788-04	BX64	97J5801	5VX670	100245-21	H-1-3/16	105616-02	105616-02	105616-02		
10	10	1045	1285	1VP65x1-3/8	78M7101	1B5V86	78M8301	5VX660	100245-20	5VX670	100245-21	B-1-3/16	105616-01	105616-01	105616-01		
11	10	1135	1330	1VP65x1-3/8	78M7101	1B5V80	100240-05	5VX660	100245-20	5VX660	100245-20	B-1-3/16	105616-01	105616-01	105616-01		

Refrigerant Leak Detection System

A-System Test

- 1 - Initiate Refrigerant Leak Detection System Test by using the following mobile service app menu path:

RTU MENU > COMPONENT TEST > LEAK DETECTION > START TEST

- 2 - Ensure that indoor blower, outdoor fan, and combustion air blower (LGT only) are energized.

Cooling Start-Up

IMPORTANT - The crankcase heater must be energized for 24 hours before attempting to start compressor. Set thermostat so there is no demand to prevent compressors from cycling. Apply power to unit.

NOTE - These units must not be used as a "construction heater" at any time during any phase of construction. Very low return air temperatures, harmful vapors and misplacement of the filters will damage the unit and its efficiency. Additionally, a unit which will be subject to cold temperatures when not in operation must have a vapor barrier installed to seal the duct connections. Failure to protect the unit from moisture laden air or harmful vapors (generated from the construction process and temporary combustion heating equipment) will cause corrosive condensation within the unit. Failure to properly protect the unit in this situation will cause electrical and electronic component failure and could affect the unit warranty status.

A-Preliminary Checks

- 1 - Make sure that unit is installed in accordance with the installation instructions and applicable codes.
- 2 - Inspect all electrical wiring, both field and factory-installed, for loose connections. Tighten as required.
- 3 - Check to ensure that refrigerant lines do not rub against the cabinet or against other refrigerant lines.
- 4 - Check voltage at disconnect switch. Voltage must be within range listed on nameplate. If not, consult power company and have voltage condition corrected before starting unit.
- 5 - Make sure filters are in place before start-up.

B-Start-Up

Supply Air Staged Blower - Refer to the Multi-Staged Air Volume Start-Up section.

- 1 - Initiate first and second stage cooling demands using this mobile service app menu path:

SERVICE > TEST > COOLING > COOL4

Instructions provided with the thermostat may also be used to initiate cooling.

- 2 - First-stage thermostat demand will energize indoor blower in Low Cooling CFM and associated first-stage compressors. Second-stage thermostat demand will energize indoor blower in High Cooling CFM and all remaining compressors.

- 3 - 156 -

Units contain two refrigerant circuits or systems. See FIGURE 24.

180 -

Units contain three refrigerant circuits or systems. See FIGURE 25.

210, 240, 300 -

Units contain four refrigerant circuits or systems. See FIGURE 26.

- 4 - Each refrigerant circuit is separately charged with R454B refrigerant. See unit rating plate for correct amount of charge.
- 5 - Refer to the Refrigerant Check and Charge section to check refrigerant charge.

C-R454B Refrigerant

Units charged with R454B refrigerant operate at lower pressures than R410A. The expansion valve and liquid line dryer provided with the unit are approved for use with R454B .

R454B refrigerant is stored in a gray cylinder.

CAUTION

Mineral oils are not compatible with R454B. If oil must be added, it must be a polyol ester oil.

Manifold gauge sets used with systems charged with R454B refrigerant must be capable of handling various system operating pressures. The gauges should be rated for use with pressures of 0-800 on the high side and a low side of 30" vacuum to 250 psi with dampened speed to 500 psi. Gauge hoses must be rated for use at up to 800 psi of pressure with a 4000 psi burst rating.

156 REFRIGERANT CIRCUITS

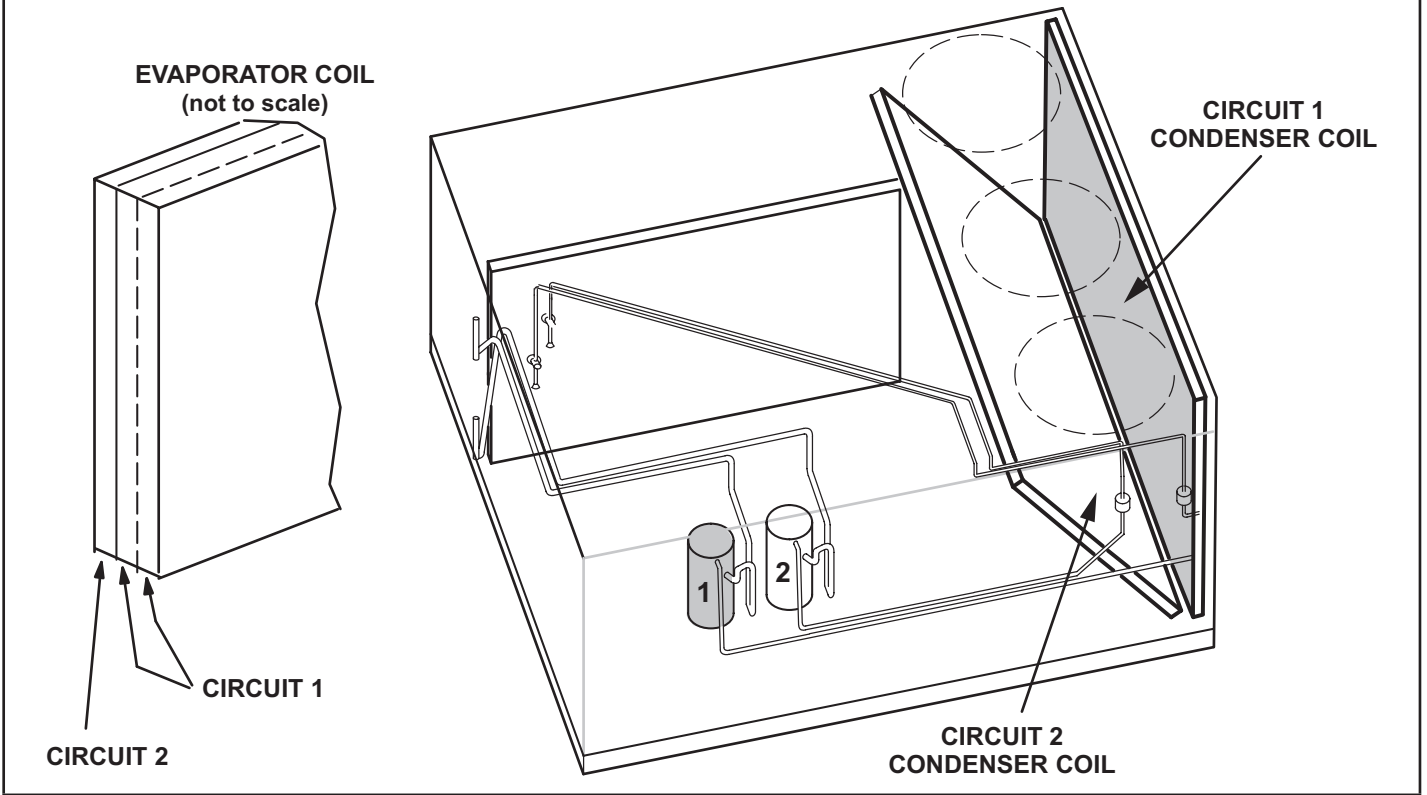

FIGURE 24

180 REFRIGERANT CIRCUITS

**ALL THREE EVAPORATOR
COIL CIRCUITS ARE
INTERTWINED**

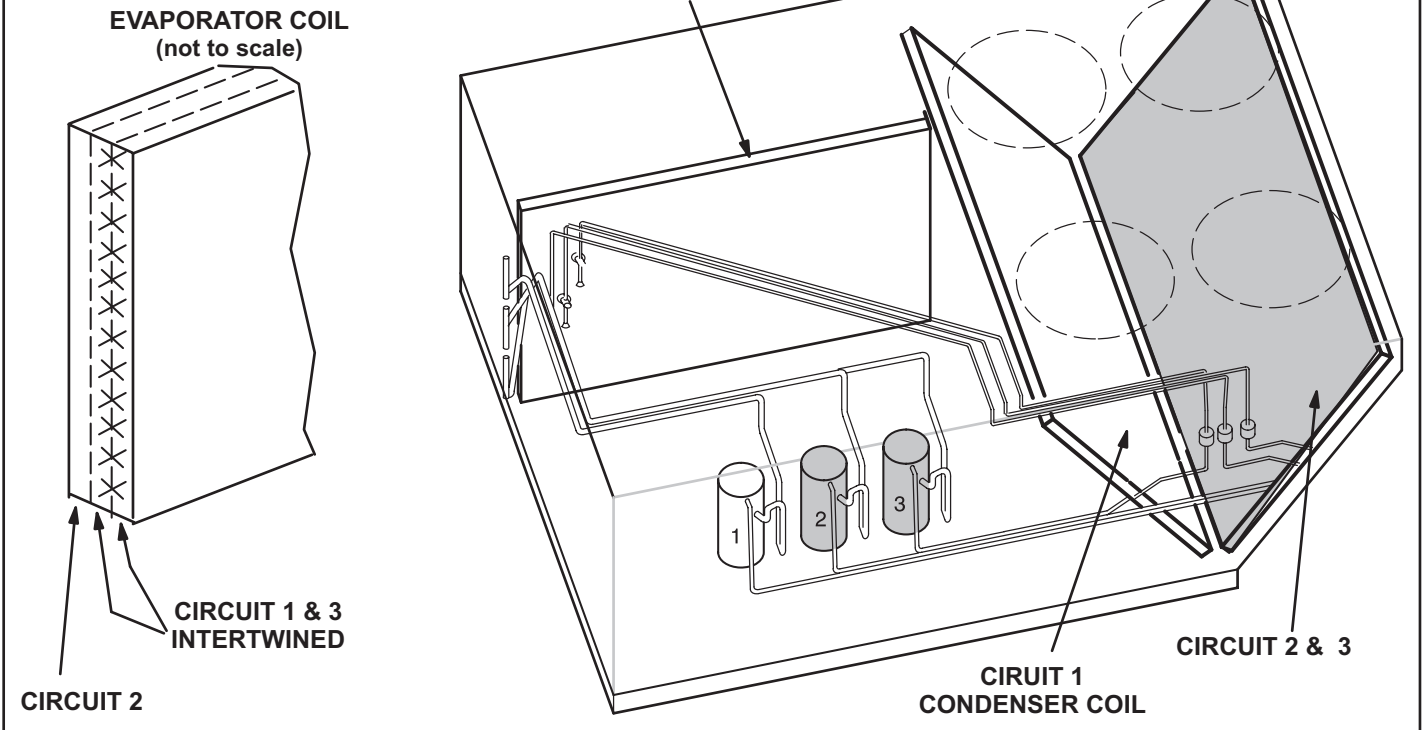

FIGURE 25

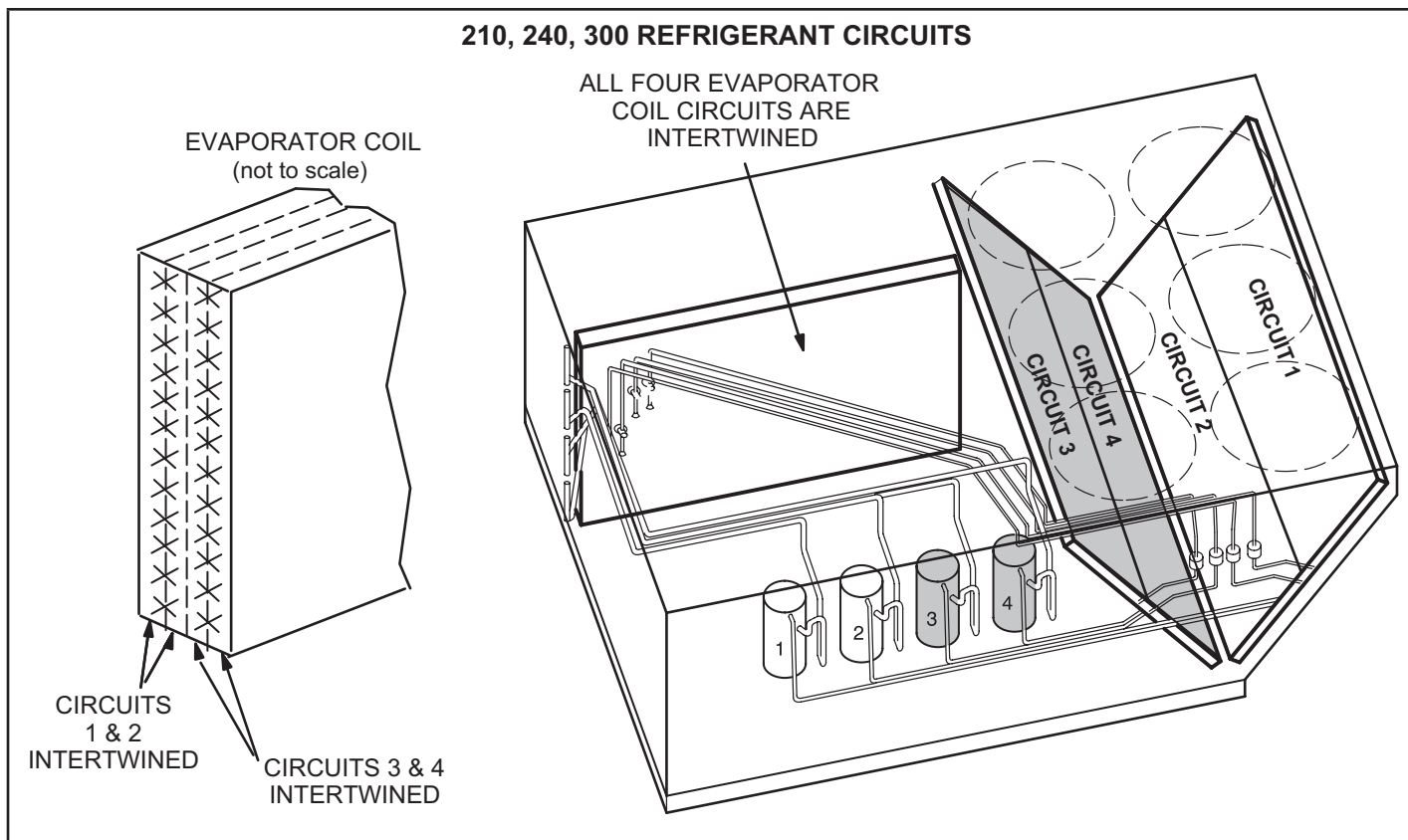

FIGURE 26

D-Refrigerant Charge and Check - All Aluminum Coil

WARNING-Do not exceed nameplate charge under any condition.

This unit is factory charged and should require no further adjustment. If the system requires additional refrigerant, reclaim the charge, evacuate the system, and add required nameplate charge.

NOTE - System charging is not recommended below 60cF (15cC). In temperatures below 60cF (15cC), the charge must be weighed into the system.

If weighing facilities are not available, or to check the charge, use the following procedure:

IMPORTANT - Charge unit in normal cooling mode.

- 1 - Attach gauge manifolds to discharge and suction lines. With the economizer disabled, operate the unit in **cooling mode at high speed** using the following mobile service app menu path:

SERVICE>TEST>COOL>COOL 4

- 2 - Use a thermometer to accurately measure the outdoor ambient temperature.
- 3 - Apply the outdoor temperature to TABLE 5 through TABLE 14 to determine normal operating pressures. Pressures are listed for sea level applications at 80°F dry bulb and 67°F wet bulb return air.
- 4 - Compare the normal operating pressures to the pressures obtained from the gauges.

Minor variations in the pressures may be expected due to differences in installations. Significant differences could mean that the system is not properly charged or that a problem exists with some component in the system. **Correct any system problems before proceeding.**

- 5 - If discharge pressure is high, remove refrigerant from the system. If discharge pressure is low, add refrigerant to the system.
 - Add or remove charge in increments.
 - Allow the system to stabilize each time refrigerant is added or removed.
- 6 - Confirm charge amount using liquid temperature plots. Fine tune charge amount(s) to match liquid temperature plots as needed per the next section.

E-Charge Confirmation and Fine Tuning - Liquid Temperature Check

NOTE - Pressures are listed for sea level applications.

- 1 - Use the same thermometer to accurately measure the liquid temperature (in the outdoor section).
 - If measured liquid temperature is higher than the target liquid temperature, add refrigerant to the system.
 - If measured liquid temperature is lower than the target liquid temperature, recover some refrigerant from the system.

- 2 - Add or remove charge in increments. Allow the system to stabilize each time refrigerant is added or removed.
- 3 - Continue the process until measured liquid temperature agrees with the target liquid temperature. Do not go below the target liquid temperature when adjusting charge. Note that suction pressure can change as charge is adjusted.

- Cylinders shall be kept in an appropriate position according to the instructions.
- Ensure that the unit is earth grounded prior to charging the system with refrigerant.
- Label the system when charging is complete (if not already).
- Extreme care shall be taken not to overfill the unit.

Prior to recharging the system, it shall be pressure-tested with the appropriate purging gas. The system shall be leak-tested on completion of charging but prior to commissioning. A follow up leak test shall be carried out prior to leaving the site.

- When removing refrigerant from a system, either for servicing or decommissioning, it is recommended good practice that all refrigerants are removed safely.
- When transferring refrigerant into cylinders, ensure that only appropriate refrigerant recovery cylinders are employed. Ensure that the correct number of cylinders for holding the total system charge is available. All cylinders to be used are designated for the recovered refrigerant and labelled for that refrigerant (i. e. special cylinders for the recovery of refrigerant). Cylinders shall be complete with pressure-relief valve and associated shut-off valves in good working order. Empty recovery cylinders are evacuated and, if possible, cooled before recovery.
- The recovery equipment shall be in good working order with a set of instructions concerning the equipment that is at hand and shall be suitable for the recovery of all appropriate refrigerants including, when applicable, flammable refrigerants. In addition, a set of calibrated weighing scales shall be available and in good working order. Hoses shall be complete with leak-free disconnect couplings and in good condition. Before using the recovery machine, check that it is in satisfactory working order, has been properly maintained and that any associated electrical components are sealed to prevent ignition in the event of a refrigerant release. Consult manufacturer if in doubt.
- The recovered refrigerant shall be returned to the refrigerant supplier in the correct recovery cylinder, and the relevant waste transfer note arranged. Do not mix refrigerants in recovery units and especially
- If compressors or compressor oils are to be removed, ensure that they have been evacuated to an acceptable level to make certain that flammable refrigerant does not remain within the lubricant. The evacuation process shall be carried out prior to returning the compressor to the suppliers. Only electric heating to the compressor body shall be employed to accelerate this process. When oil is drained from a system, it shall be carried out safely.

Refrigerant Charge R-454B		
Unit	M _c (lbs)	M _c (kg)
LGT/LCT156 STG 1	9.00	4.08
LGT/LCT156 STG 2	7.63	3.46
LGT/LCT180 STG 1	5.90	2.68
LGT/LCT180 STG 2	5.50	2.49
LGT/LCT180 STG 3	5.00	2.27
LGT/LCT210 STG 1	5.69	2.58
LGT/LCT210 STG 2	5.88	2.66
LGT/LCT210 STG 3	5.19	2.35
LGT/LCT210 STG 4	5.31	2.41
LGT/LCT240 STG 1	6.00	2.72
LGT/LCT240 STG 2	6.75	3.06
LGT/LCT240 STG 3	5.00	2.27
LGT/LCT240 STG 4	5.31	2.41
LGT/LCT300 STG 1	5.94	2.69
LGT/LCT300 STG 2	5.46	2.48
LGT/LCT300 STG 3	5.34	2.42
LGT/LCT300 STG 4	5.38	2.44
LGT/LCT156 STG 1 W/ Humidrol	9.00	4.08
LGT/LCT156 STG 2 W/ Humidrol	7.94	3.60
LGT/LCT180 STG 1 W/ Humidrol	6.44	2.92
LGT/LCT180 STG 2 W/ Humidrol	6.03	2.74
LGT/LCT180 STG 3 W/ Humidrol	6.00	2.72
LGT/LCT210 STG 1 W/ Humidrol	6.00	2.72
LGT/LCT210 STG 2 W/ Humidrol	6.69	3.03
LGT/LCT210 STG 3 W/ Humidrol	5.25	2.38
LGT/LCT210 STG 4 W/ Humidrol	5.00	2.27
LGT/LCT240 STG 1 W/ Humidrol	6.50	2.95
LGT/LCT240 STG 2 W/ Humidrol	6.50	2.95
LGT/LCT240 STG 3 W/ Humidrol	5.00	2.27
LGT/LCT240 STG 4 W/ Humidrol	5.00	2.27
LGT/LCT300 STG 1 W/ Humidrol	6.38	2.89
LGT/LCT300 STG 2 W/ Humidrol	6.13	2.78
LGT/LCT300 STG 3 W/ Humidrol	5.13	2.32
LGT/LCT300 STG 4 W/ Humidrol	5.75	2.61

In addition to conventional charging procedures, the following requirements shall be followed.

- Ensure that contamination of different refrigerants does not occur when using charging equipment. Hoses or lines shall be as short as possible to minimize the amount of refrigerant contained in them.

NOTE - System charging is not recommended below 60°F (15°C). In temperatures below 60°F (15°C), the charge must be weighed into the system.

If weighing facilities are not available, or to check the charge, use the following procedure:

- 1 - Make sure outdoor coil is clean. Attach gauge manifolds and operate unit at full CFM in cooling mode with economizer disabled until system stabilizes (approximately five minutes). Make sure all outdoor air dampers are closed.
- 2 - Compare the normal operating pressures to the pressures obtained from the gauges. Check unit components if there are significant differences.
- 3 - Measure the outdoor ambient temperature and the suction pressure. Refer to the charging curve to determine a target liquid temperature.

NOTE - Pressures are listed for sea level applications.

- 4 - Use the same thermometer to accurately measure the liquid temperature (in the outdoor section).
 - If measured liquid temperature is higher than the target liquid temperature, add refrigerant to the system.
 - If measured liquid temperature is lower than the target liquid temperature, recover some refrigerant from the system..
- 5 - Add or remove charge in increments. Allow the system to stabilize each time refrigerant is added or removed.
- 6 - Continue the process until measured liquid temperature agrees with the target liquid temperature. Do not go below the target liquid temperature when adjusting charge. Note that suction pressure can change as charge is adjusted.
- 7 - Example: 156 model, no reheat - 95°F outdoor ambient and a measured suction pressure of 130psig, the target liquid temperature is 96°F. For a measured liquid temperature of 106°F, add charge in increments until measured liquid temperature agrees with the target liquid temperature.

TABLE 5
LGT/LCT 156 NO REHEAT OPERATING PRESSURES - ALL-ALUMINUM OD COIL - 581081-02

Outdoor Coil Entering Air Temperature												
	65°F		75°F		85°F		95°F		105°F		115°F	
	Suct (psig)	Disc (psig)	Suct (psig)	Disc (psig)	Suct (psig)	Disc (psig)	Suct (psig)	Disc (psig)	Suct (psig)	Disc (psig)	Suct (psig)	Disc (psig)
Circuit 1	102	217	104	253	106	294	108	340	110	390	111	446
	109	219	112	255	114	295	117	341	119	392	121	447
	123	224	127	259	131	300	136	345	138	396	141	451
	138	231	144	266	149	306	154	352	159	402	163	457
Circuit 2	102	230	105	267	107	309	108	356	109	408	108	464
	108	233	112	270	114	312	117	359	118	411	119	468
	119	240	124	277	129	320	134	360	137	419	139	475
	130	247	138	285	144	328	150	375	155	427	160	484

LGT/LCT 156 NO REHEAT CHARGING CURVE CIRCUIT 1 - ALL-ALUMINUM OD COIL - 581082-02

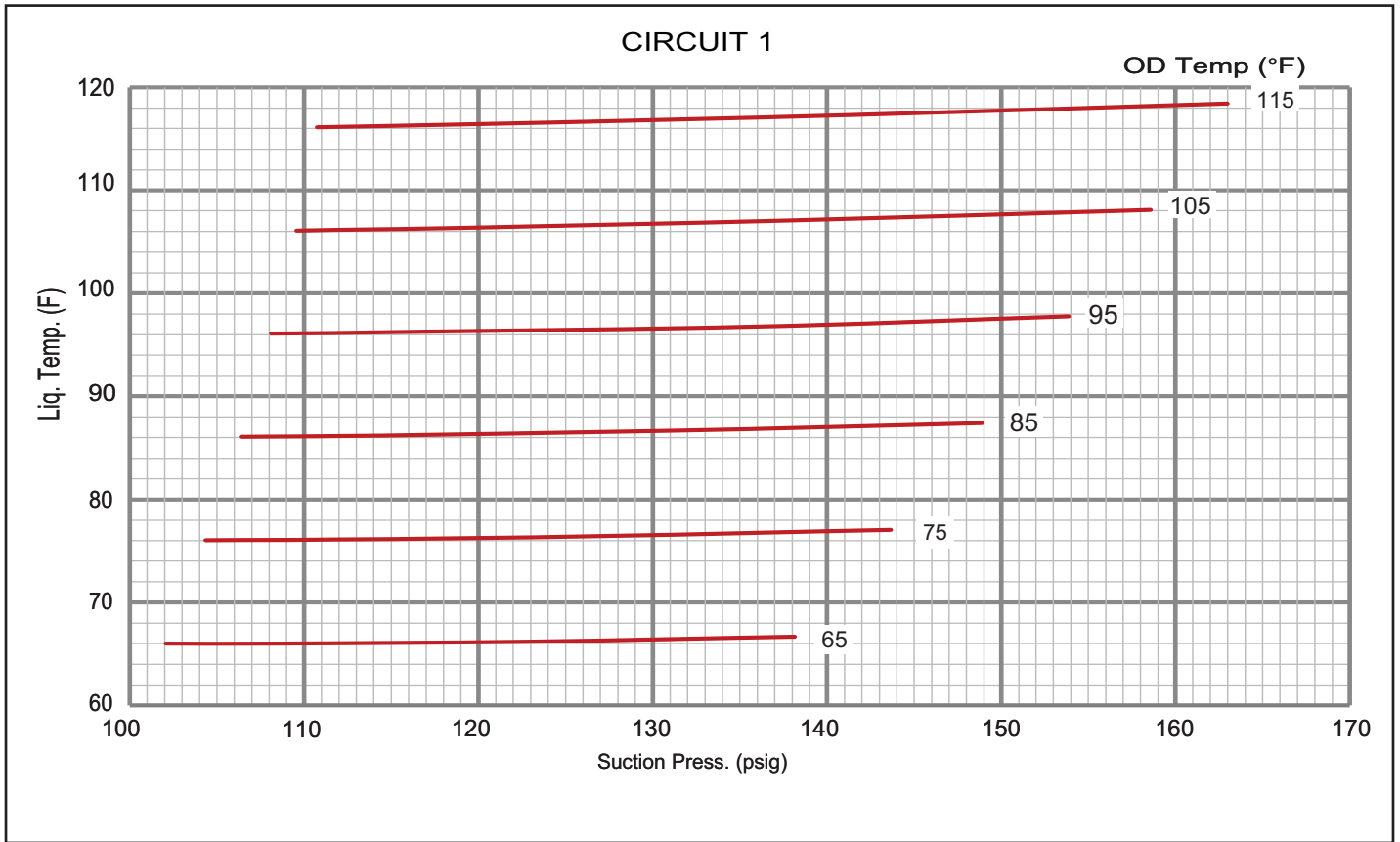

LGT/LCT 156 NO REHEAT CHARGING CURVE CIRCUIT 2 - ALL-ALUMINUM OD COIL - 581082-02

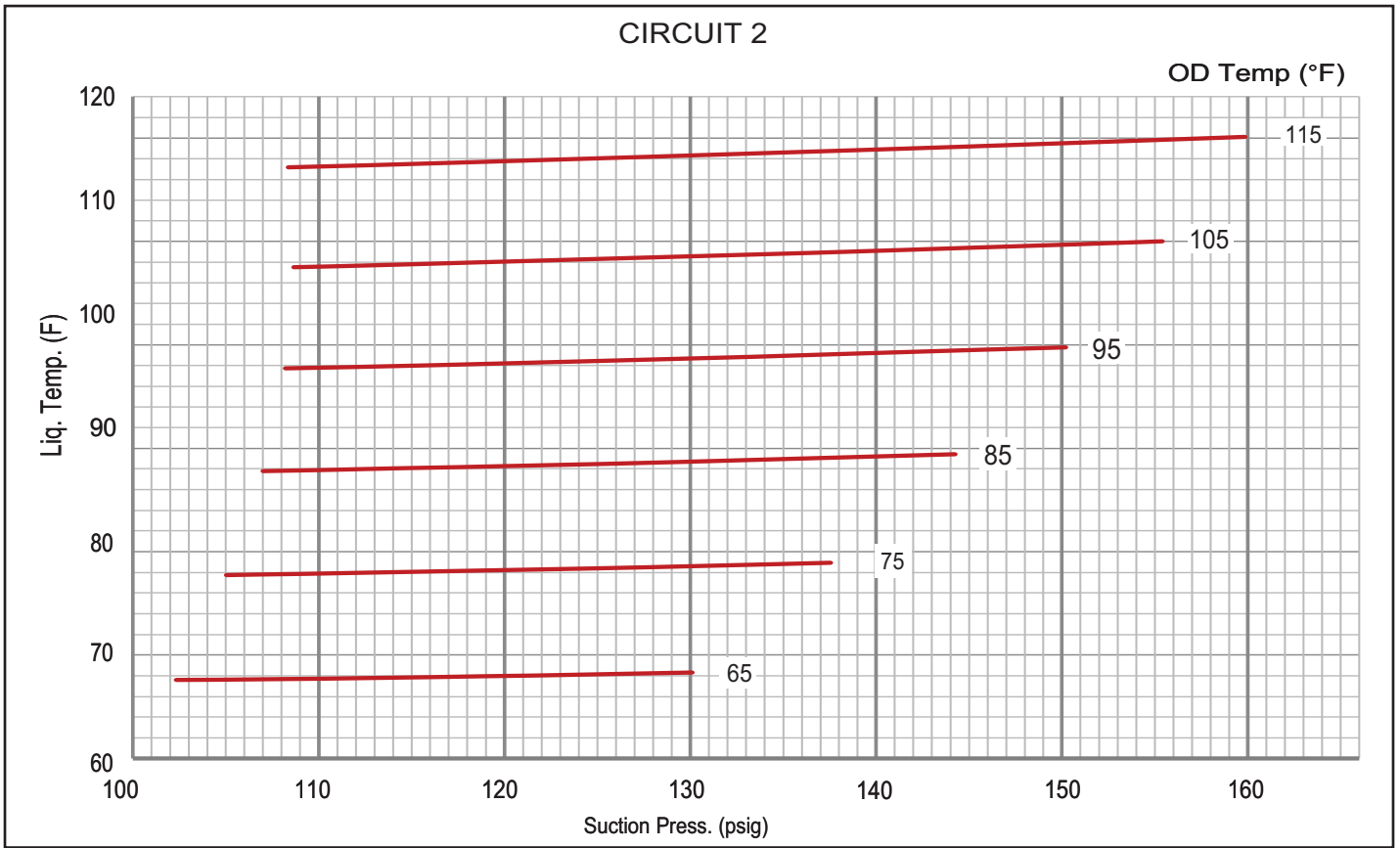
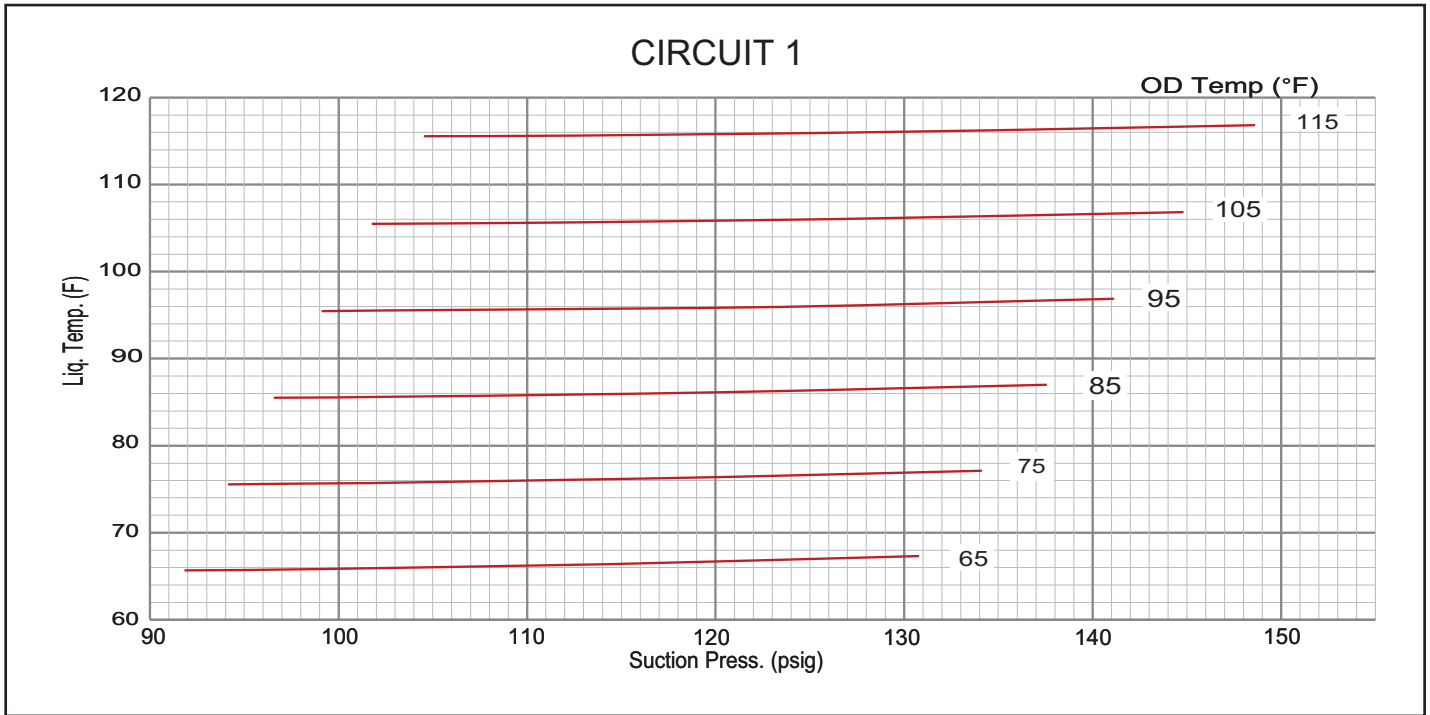

TABLE 6
LGT/LCT 180 NO REHEAT OPERATING PRESSURES - ALL-ALUMINUM OD COIL - 581085-02

Outdoor Coil Entering Air Temperature												
	65°F		75°F		85°F		95°F		105°F		115°F	
	Suct (psig)	Disc (psig)	Suct (psig)	Disc (psig)	Suct (psig)	Disc (psig)	Suct (psig)	Disc (psig)	Suct (psig)	Disc (psig)	Suct (psig)	Disc (psig)
Circuit 1	92	208	94	242	97	281	99	324	102	371	105	423
	99	210	102	244	104	283	107	327	110	374	113	426
	114	214	117	248	120	288	124	332	127	379	130	431
	131	217	134	252	138	291	141	335	145	383	149	436
Circuit 2	109	224	110	261	113	303	115	351	117	402	119	459
	116	227	118	264	121	306	123	353	126	405	128	462
	133	232	135	270	138	312	141	360	143	412	146	469
	150	238	153	275	156	318	159	365	162	418	166	475
Circuit 3	94	225	95	263	97	306	99	353	101	404	103	461
	101	229	103	266	105	309	107	356	109	408	111	464
	117	235	119	273	121	315	124	363	127	415	130	471
	133	241	136	279	139	322	142	369	146	421	149	478

LGT/LCT 180 NO REHEAT CHARGING CURVE CIRCUIT 1 - ALL-ALUMINUM OD COIL - 581086-02



V

LGT/LCT 180 NO REHEAT CHARGING CURVE CIRCUIT 2 - ALL-ALUMINUM OD COIL - 581086-02

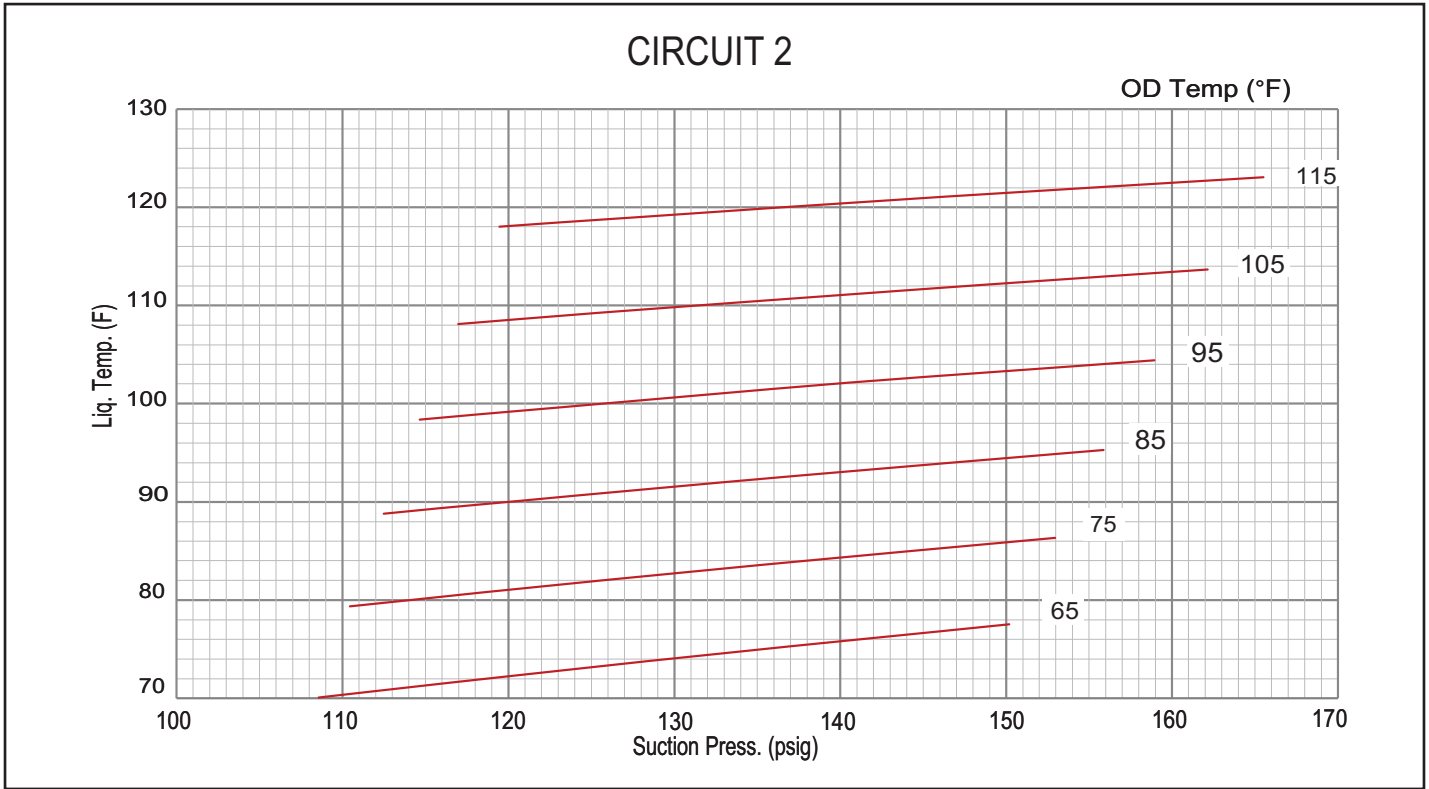

LGT/LCT 180 NO REHEAT CHARGING CURVE CIRCUIT 3 - ALL-ALUMINUM OD COIL - 581086-02

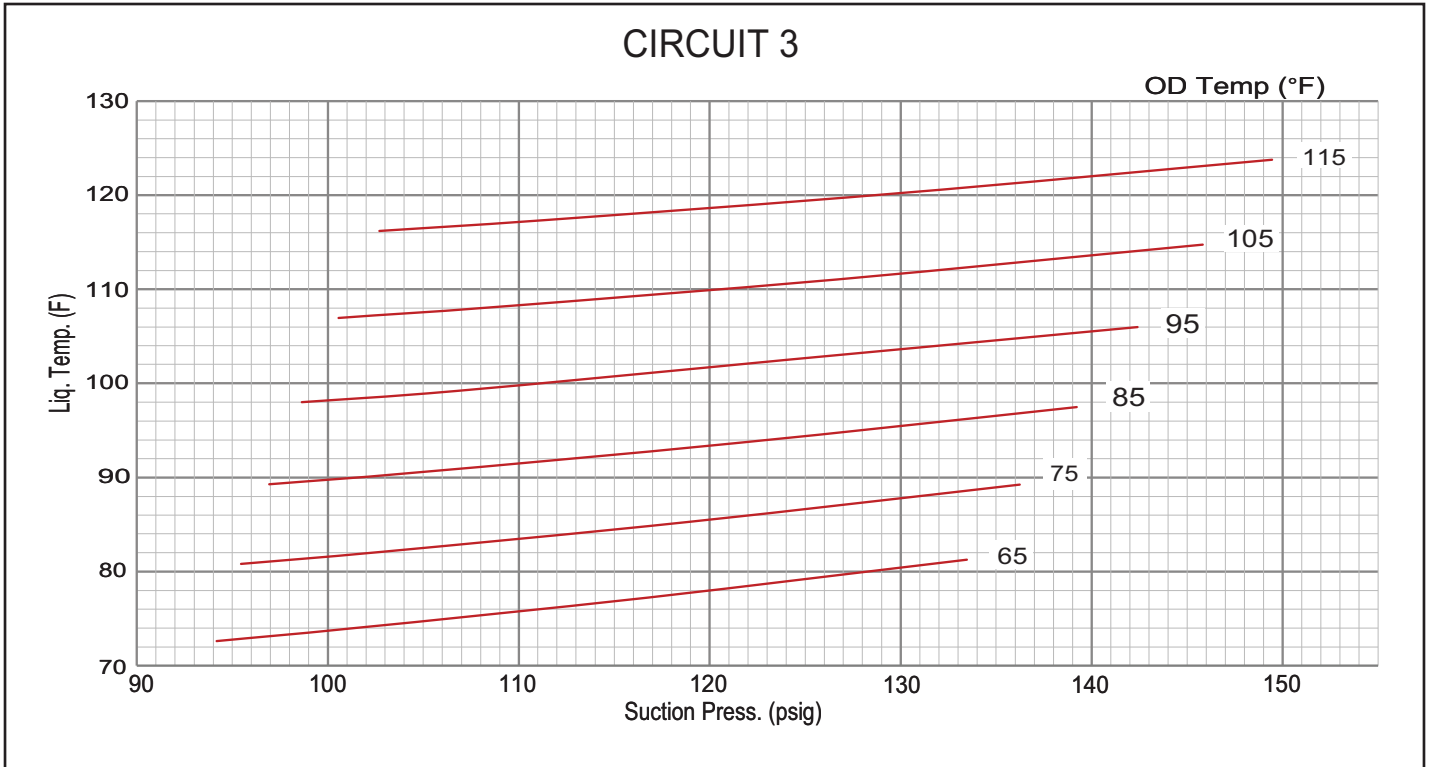
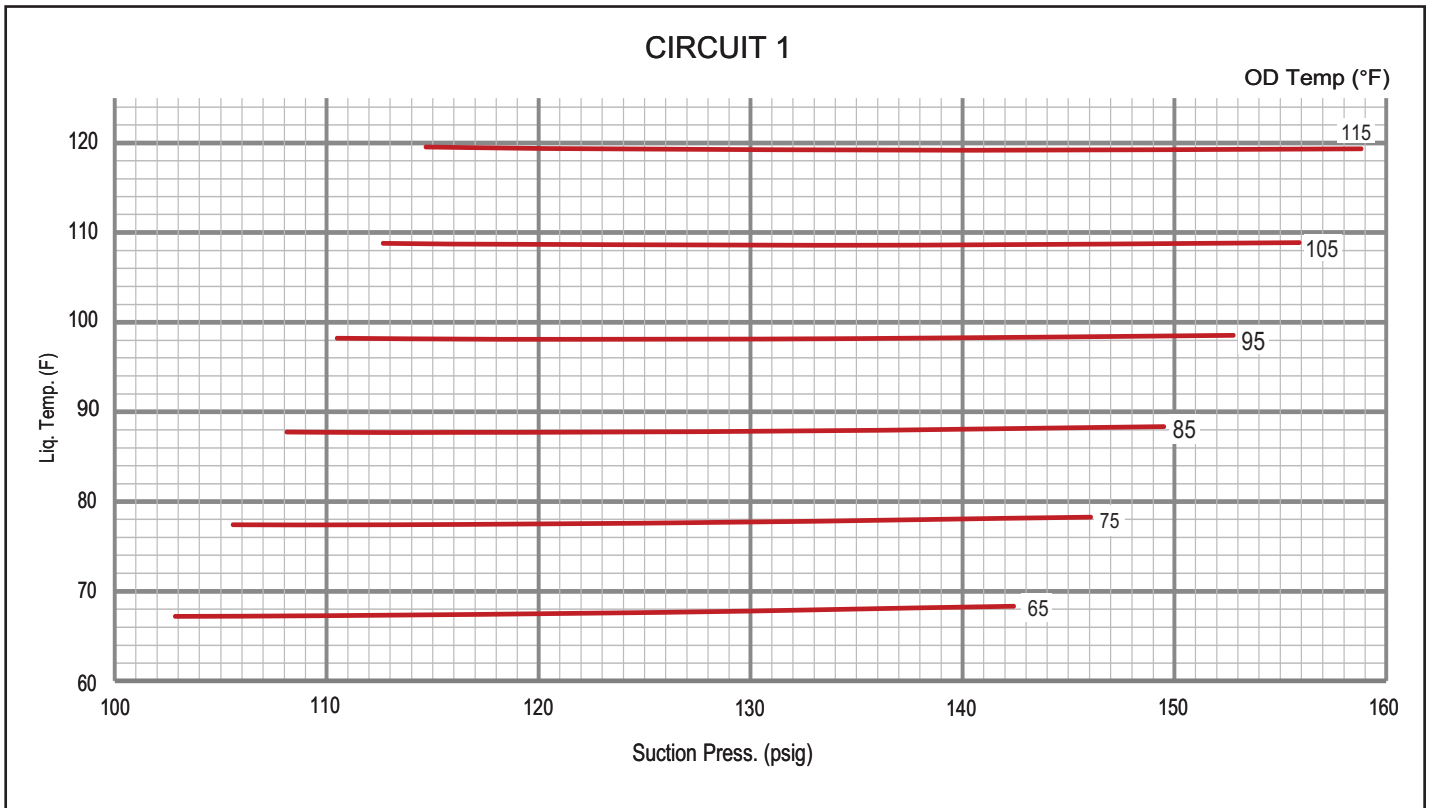

TABLE 7
LGT/LCT 210 NO REHEAT NORMAL OPERATING PRESSURES - ALL-ALUMINUM OD COIL - 581089-02

Outdoor Coil Entering Air Temperature												
	65°F		75°F		85°F		95°F		105°F		115°F	
	Suct (psig)	Disc (psig)	Suct (psig)	Disc (psig)	Suct (psig)	Disc (psig)	Suct (psig)	Disc (psig)	Suct (psig)	Disc (psig)	Suct (psig)	Disc (psig)
Circuit 1	103	220	106	257	108	300	110	349	113	405	115	466
	110	223	113	259	116	302	118	350	121	405	123	467
	126	228	129	264	132	305	135	353	138	408	140	468
	142	234	146	269	150	310	153	357	156	410	159	470
Circuit 2	111	226	114	264	116	307	118	355	120	408	122	467
	119	229	122	267	124	310	127	358	129	411	131	470
	135	236	138	273	141	316	144	364	147	418	150	476
	152	243	156	281	159	324	162	372	166	426	169	484
Circuit 3	97	221	99	258	101	300	104	347	106	399	108	455
	104	224	107	261	109	303	112	350	114	402	117	459
	120	229	123	266	126	309	129	356	132	408	134	465
	137	234	140	271	144	314	147	362	150	414	153	471
Circuit 4	97	224	99	262	101	305	103	352	105	405	107	462
	104	227	106	265	109	308	111	356	113	408	116	466
	120	233	123	272	125	315	128	363	131	415	133	473
	137	240	140	279	143	322	146	370	149	423	152	480

LGT/LCT 210 NO REHEAT CHARGING CURVE CIRCUIT 1 - ALL-ALUMINUM OD COIL - 581090-02



LGT/LCT 210 NO REHEAT CHARGING CURVE CIRCUIT 2 - ALL-ALUMINUM OD COIL - 581090-02

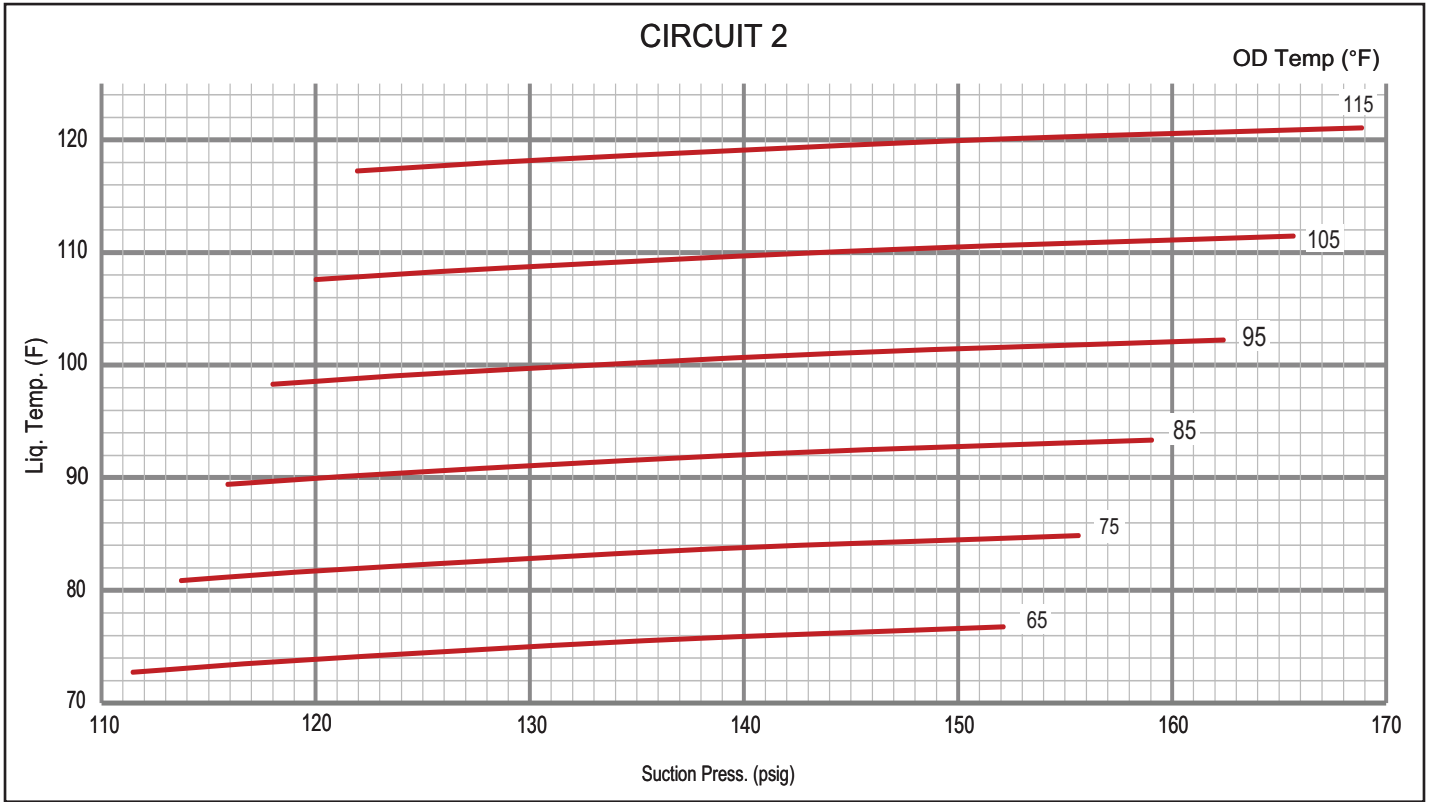

LGT/LCT 210 NO REHEAT CHARGING CURVE CIRCUIT 3 - ALL-ALUMINUM OD COIL - 581090-02

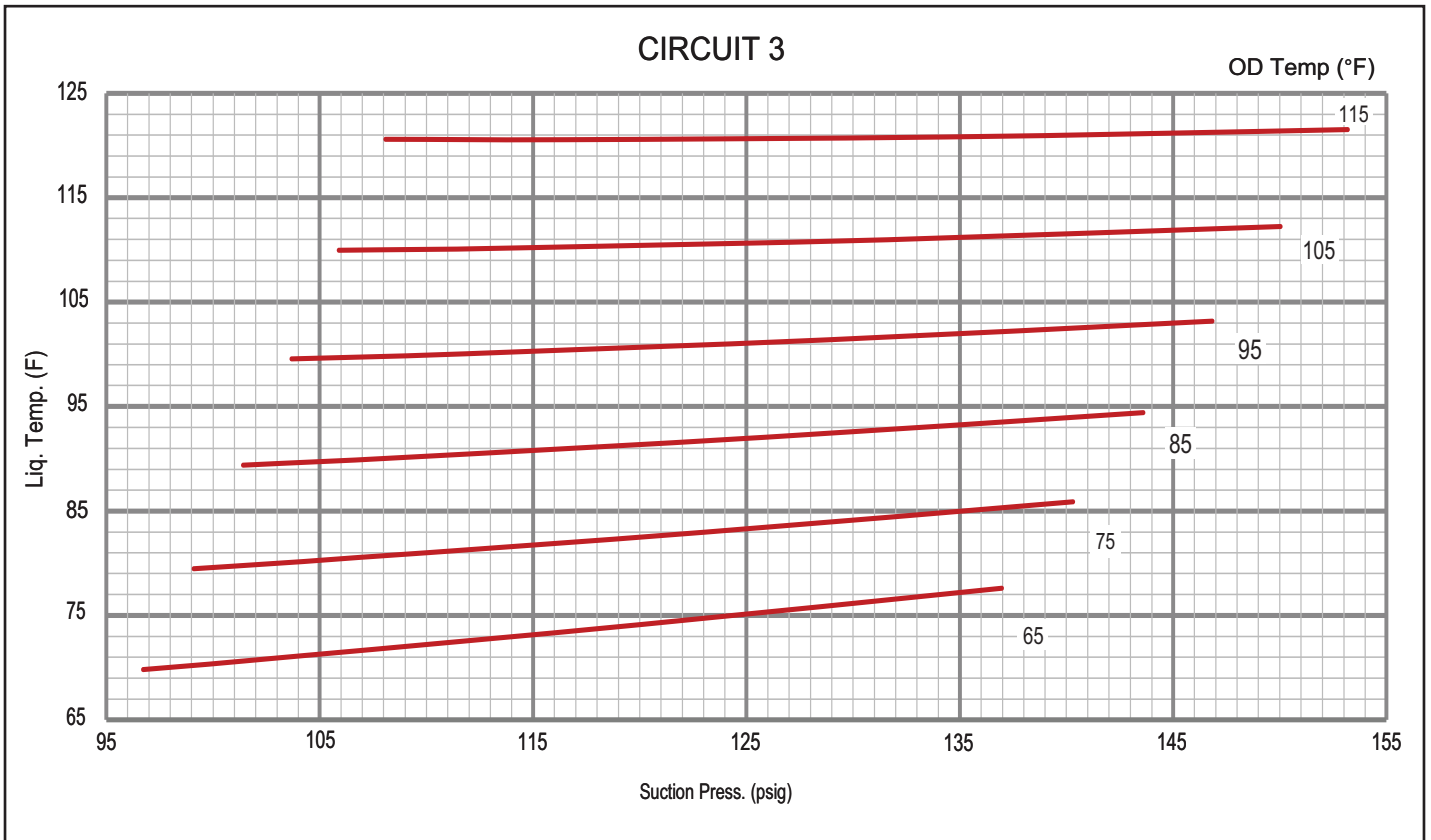

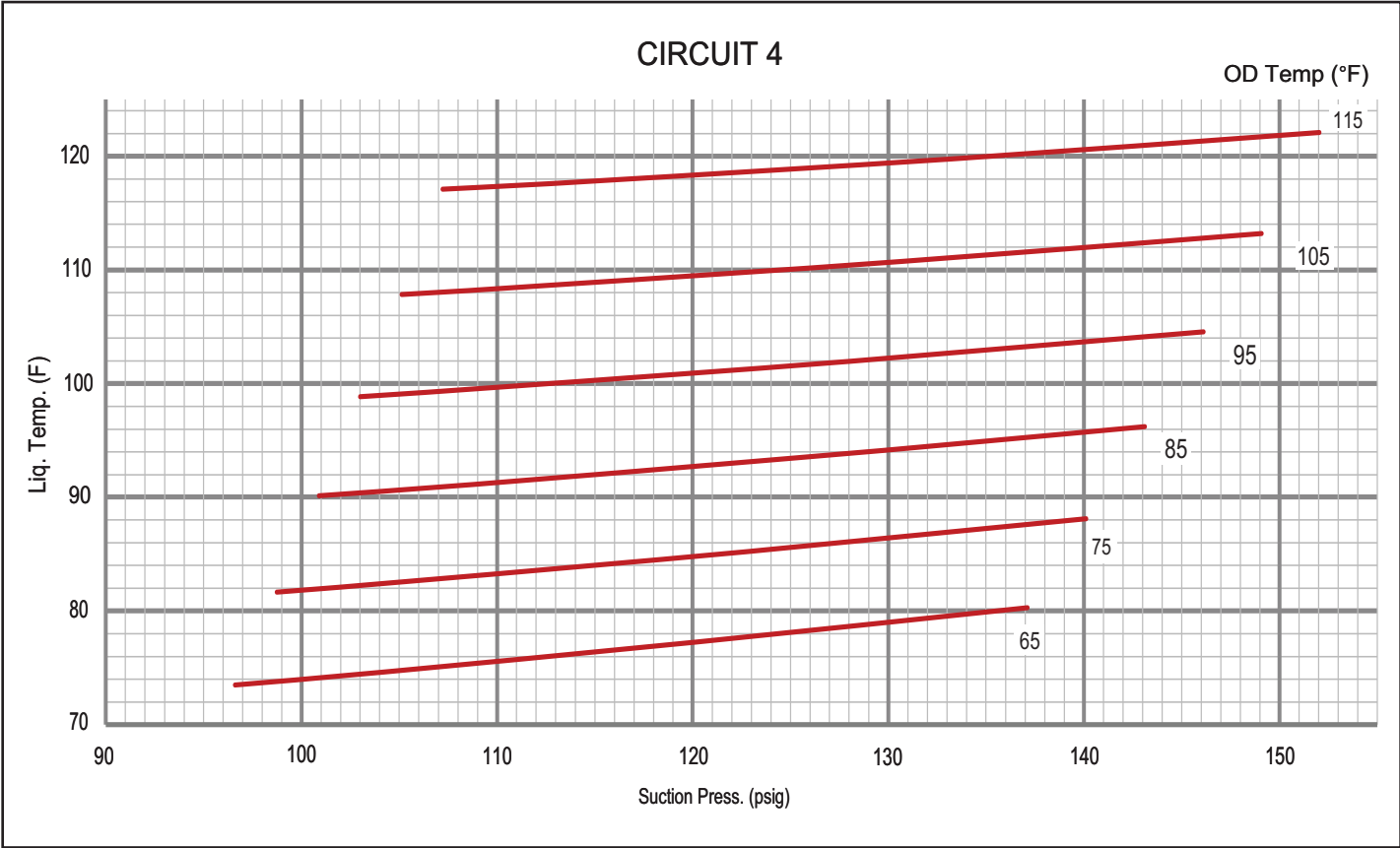
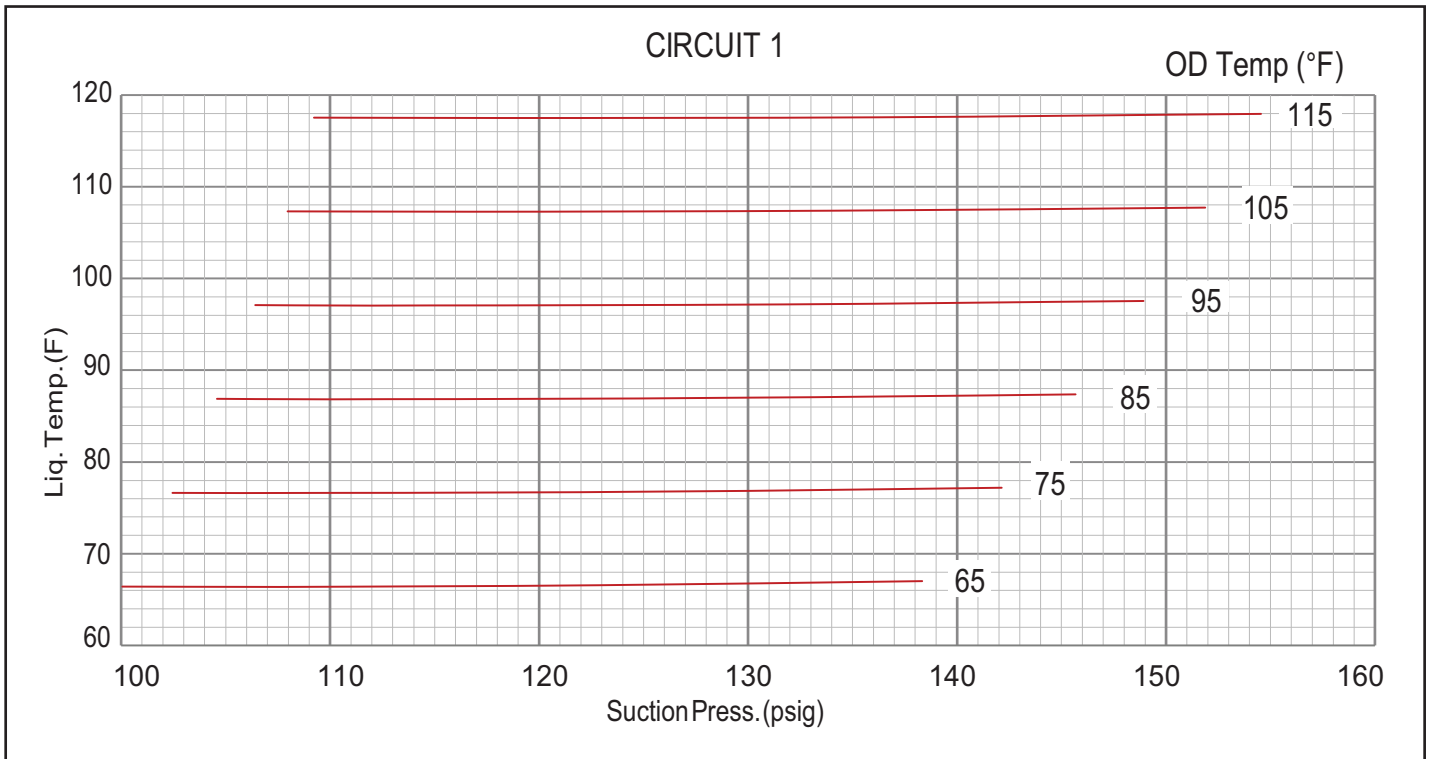

TABLE 8
LGT/LCT 240 NO REHEAT NORMAL OPERATING PRESSURES - ALL-ALUMINUM OD COIL - 581093-02

Outdoor Coil Entering Air Temperature												
	65°F		75°F		85°F		95°F		105°F		115°F	
	Suct (psig)	Disc (psig)	Suct (psig)	Disc (psig)	Suct (psig)	Disc (psig)	Suct (psig)	Disc (psig)	Suct (psig)	Disc (psig)	Suct (psig)	Disc (psig)
Circuit 1	100	223	102	259	105	301	106	347	108	398	109	454
	108	225	110	261	113	303	115	349	117	400	118	456
	123	230	126	266	129	308	132	355	134	405	136	461
	138	236	142	273	146	315	149	361	152	412	155	468
Circuit 2	106	228	109	265	111	307	113	353	114	403	116	457
	114	231	116	268	119	310	121	356	123	406	125	461
	130	237	133	275	136	317	139	363	141	414	144	469
	146	244	150	282	153	325	157	372	160	423	163	478
Circuit 3	92	224	93	261	95	303	97	349	98	399	100	453
	99	226	101	264	103	306	105	352	107	402	109	457
	114	232	117	270	119	313	122	358	124	409	127	464
	131	239	134	277	136	320	139	366	142	417	146	472
Circuit 4	94	223	96	260	98	302	99	348	101	399	102	454
	100	226	103	263	105	305	107	351	109	402	110	457
	115	232	118	269	121	311	124	358	126	409	128	465
	130	239	134	277	137	319	141	366	144	417	147	473

LGT/LCT 240 NO REHEAT CHARGING CURVE CIRCUIT 1 - ALL-ALUMINUM OD COIL - 581094-02



LGT/LCT 240 NO REHEAT CHARGING CURVE CIRCUIT 2 - ALL-ALUMINUM OD COIL - 581094-02

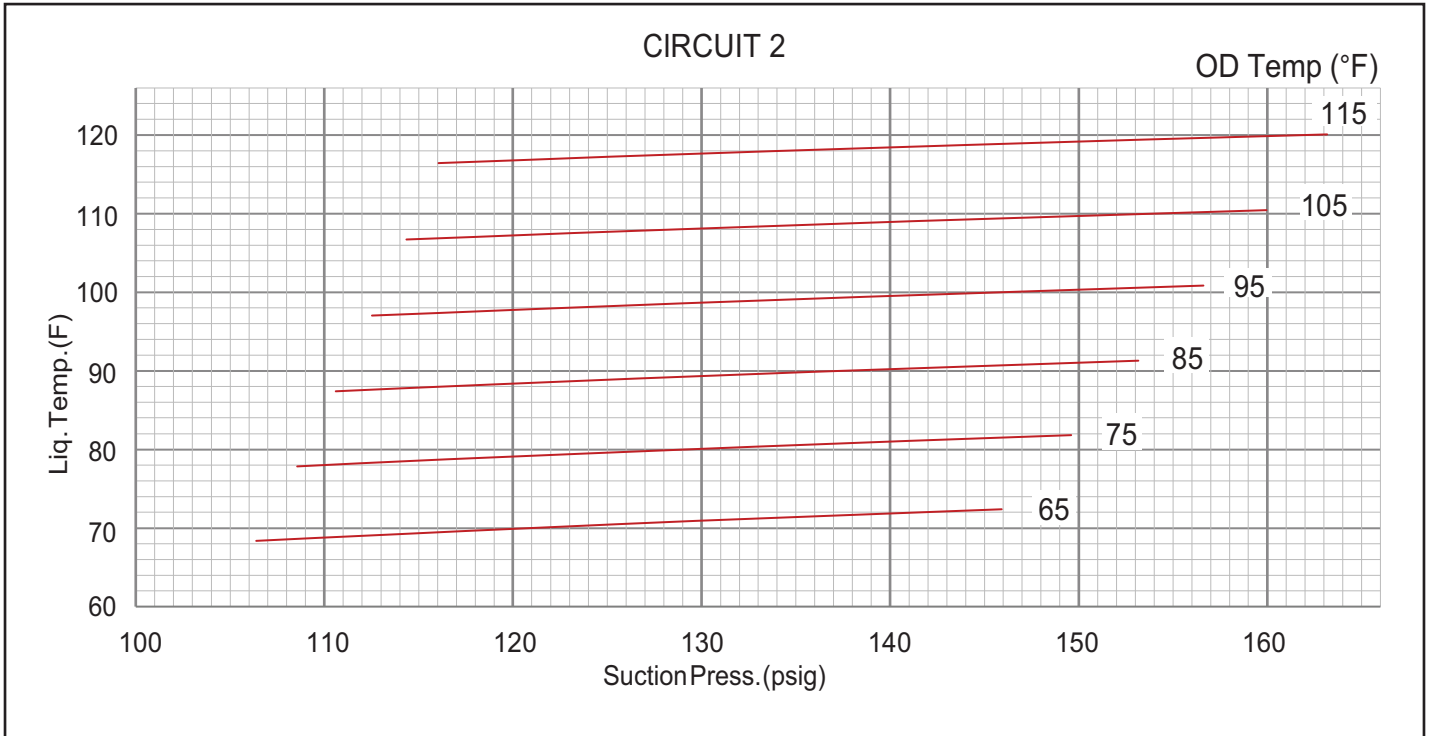

LGT/LCT 240 NO REHEAT CHARGING CURVE CIRCUIT 3 - ALL-ALUMINUM OD COIL - 581094-02

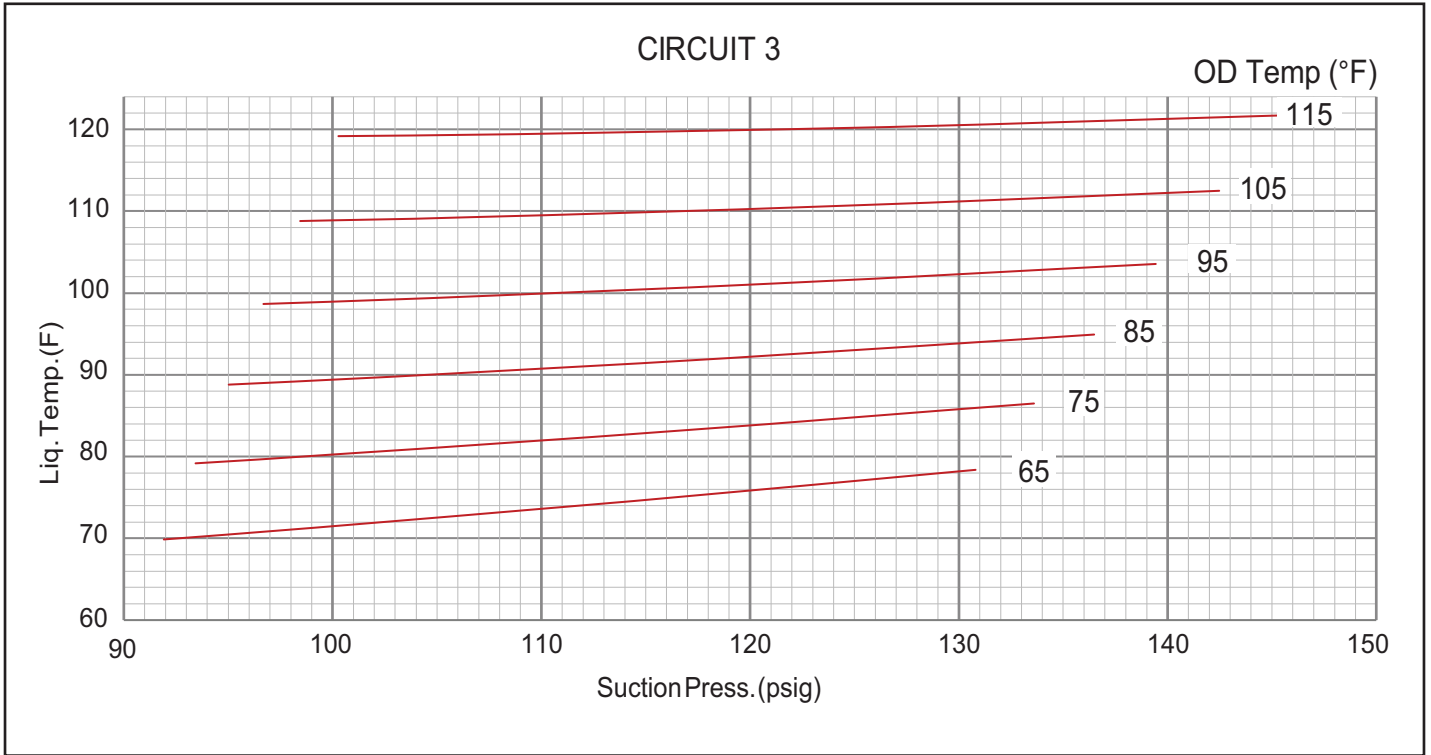

LGT/LCT 240 NO REHEAT CHARGING CURVE CIRCUIT 4 - ALL-ALUMINUM OD COIL - 581094-02

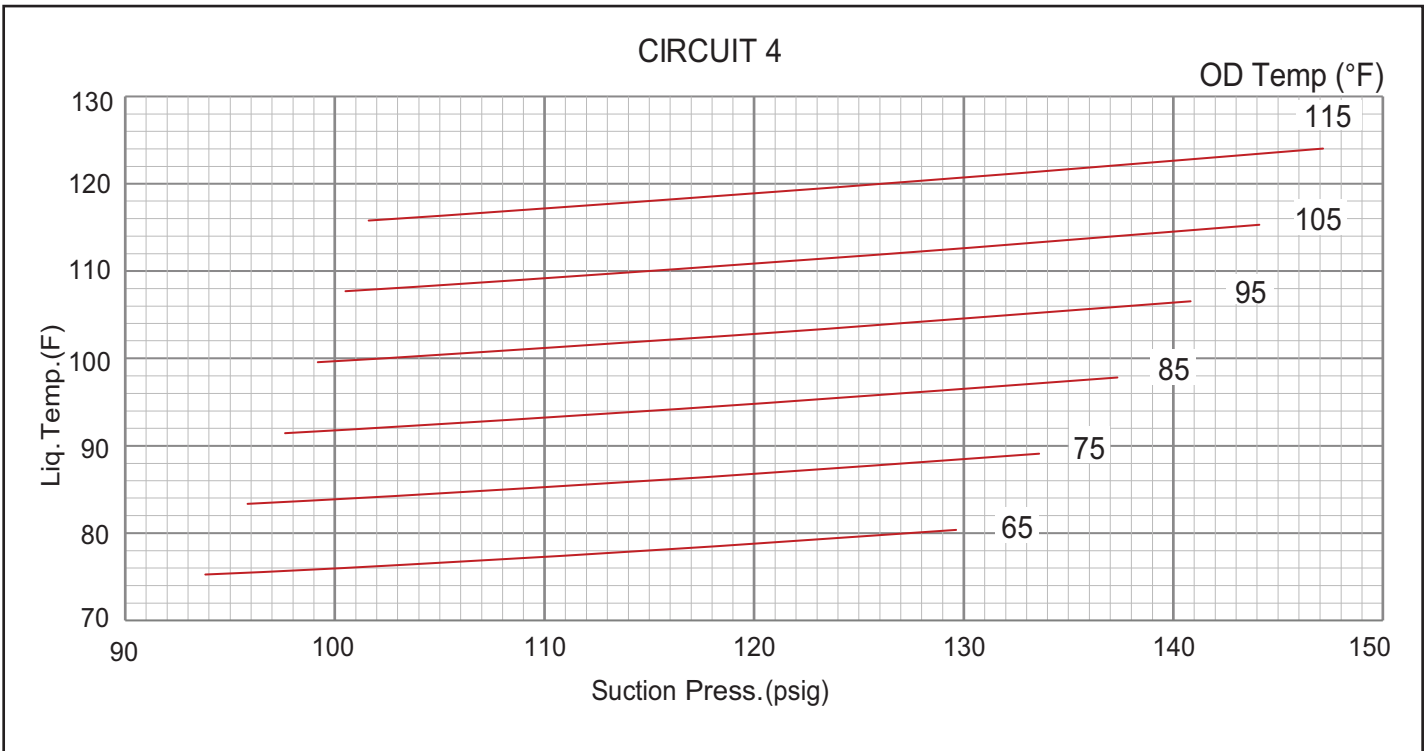
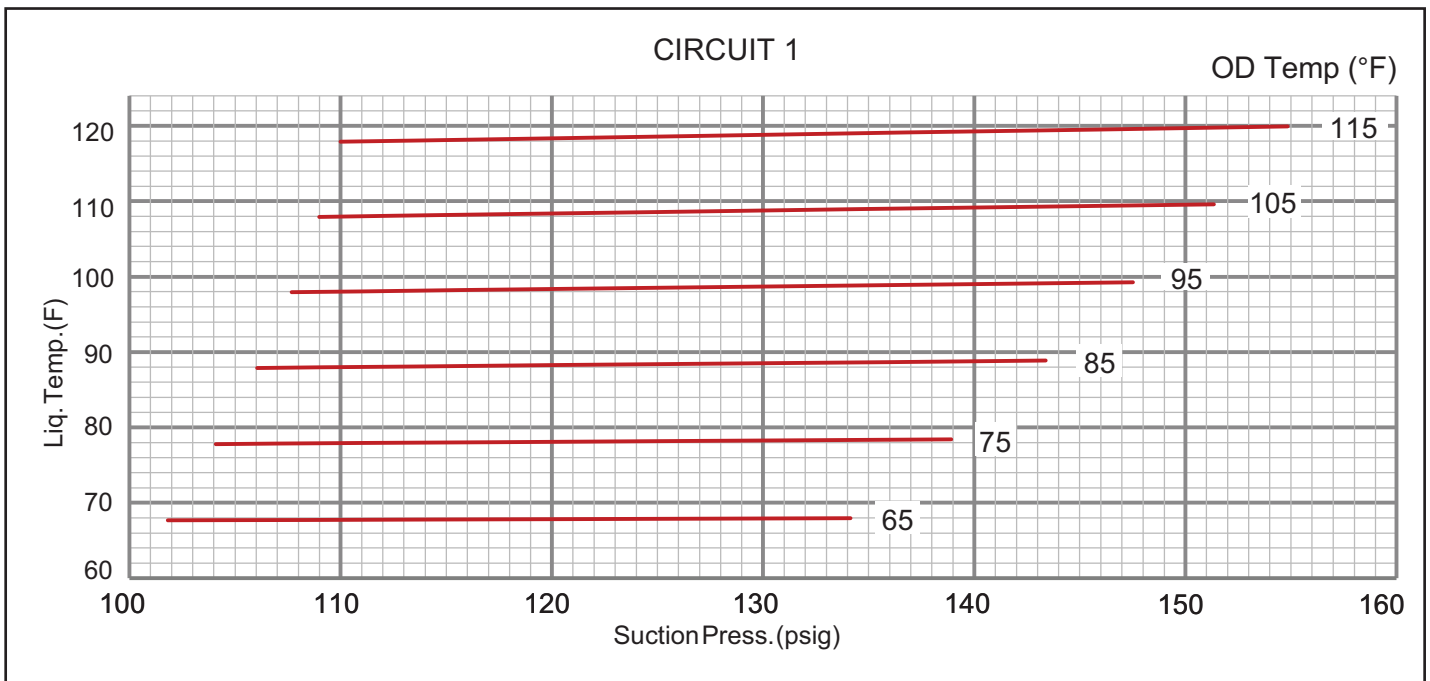

TABLE 9
LGT/LCT 300 NO REHEAT NORMAL OPERATING PRESSURES - ALL-ALUMINUM OD COIL - 581097-02

Outdoor Coil Entering Air Temperature												
	65°F		75°F		85°F		95°F		105°F		115°F	
	Suct (psig)	Disc (psig)	Suct (psig)	Disc (psig)	Suct (psig)	Disc (psig)	Suct (psig)	Disc (psig)	Suct (psig)	Disc (psig)	Suct (psig)	Disc (psig)
Circuit 1	102	229	104	267	106	309	108	356	109	408	110	465
	108	232	111	269	113	311	116	359	117	411	119	469
	121	237	125	275	128	317	132	365	134	418	137	476
	134	243	139	281	143	324	148	373	151	426	155	484
Circuit 2	102	237	104	275	106	318	108	365	109	418	110	476
	109	241	111	278	114	321	116	369	118	422	119	480
	122	248	126	286	129	329	132	376	135	430	137	489
	136	257	141	295	145	339	149	387	153	440	156	499
Circuit 3	86	234	88	272	90	315	92	363	93	416	95	475
	92	237	94	275	96	318	99	366	101	419	103	478
	105	244	108	282	111	324	114	370	117	426	120	485
	118	251	122	289	126	332	130	380	134	433	138	492
Circuit 4	90	237	92	275	94	319	96	368	98	422	100	481
	97	240	99	279	102	323	104	373	107	427	109	487
	108	248	112	288	115	333	120	384	122	439	126	499
	117	257	122	298	127	344	132	395	136	451	140	512

LGT/LCT 300 NO REHEAT CHARGING CURVE CIRCUIT 1 - ALL-ALUMINUM OD COIL - 581098-02



LGT/LCT 300 NO REHEAT CHARGING CURVE CIRCUIT 2 - ALL-ALUMINUM OD COIL - 581098-02

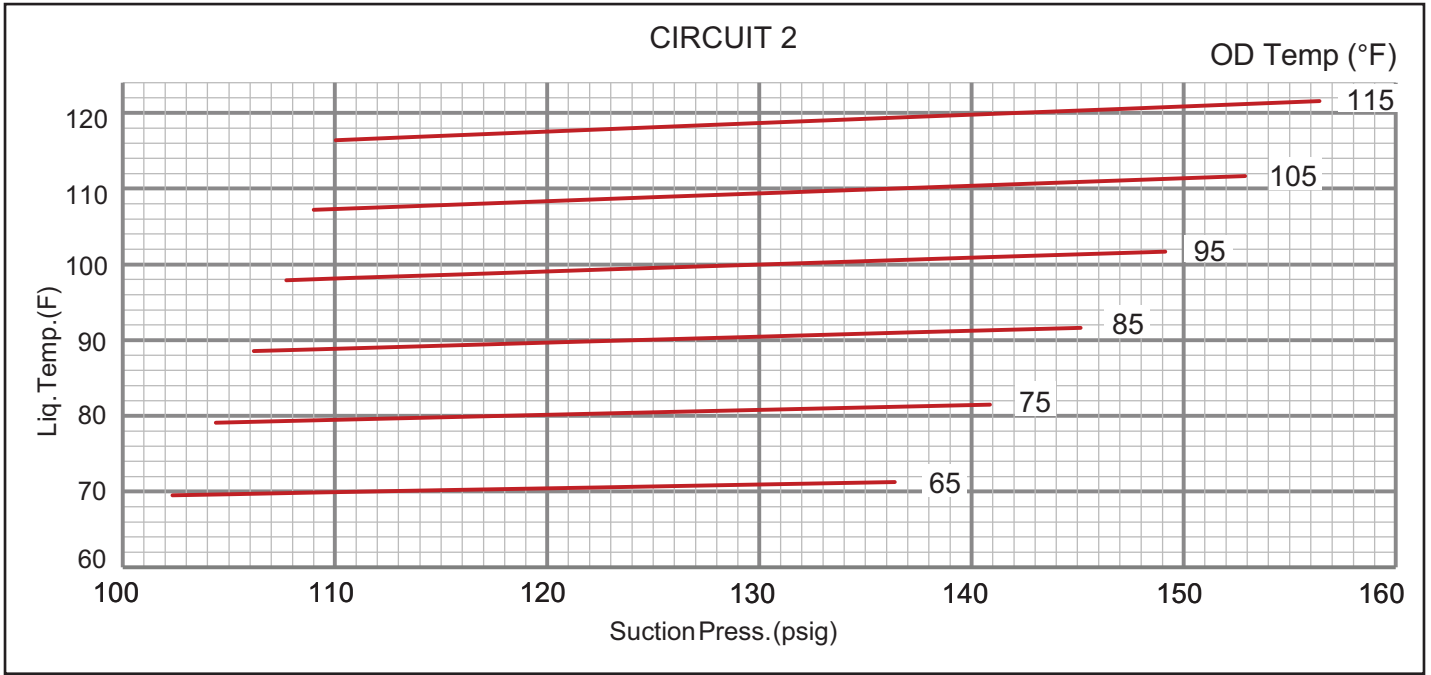

LGT/LCT 300 NO REHEAT CHARGING CURVE CIRCUIT 3 - ALL-ALUMINUM OD COIL - 581098-02

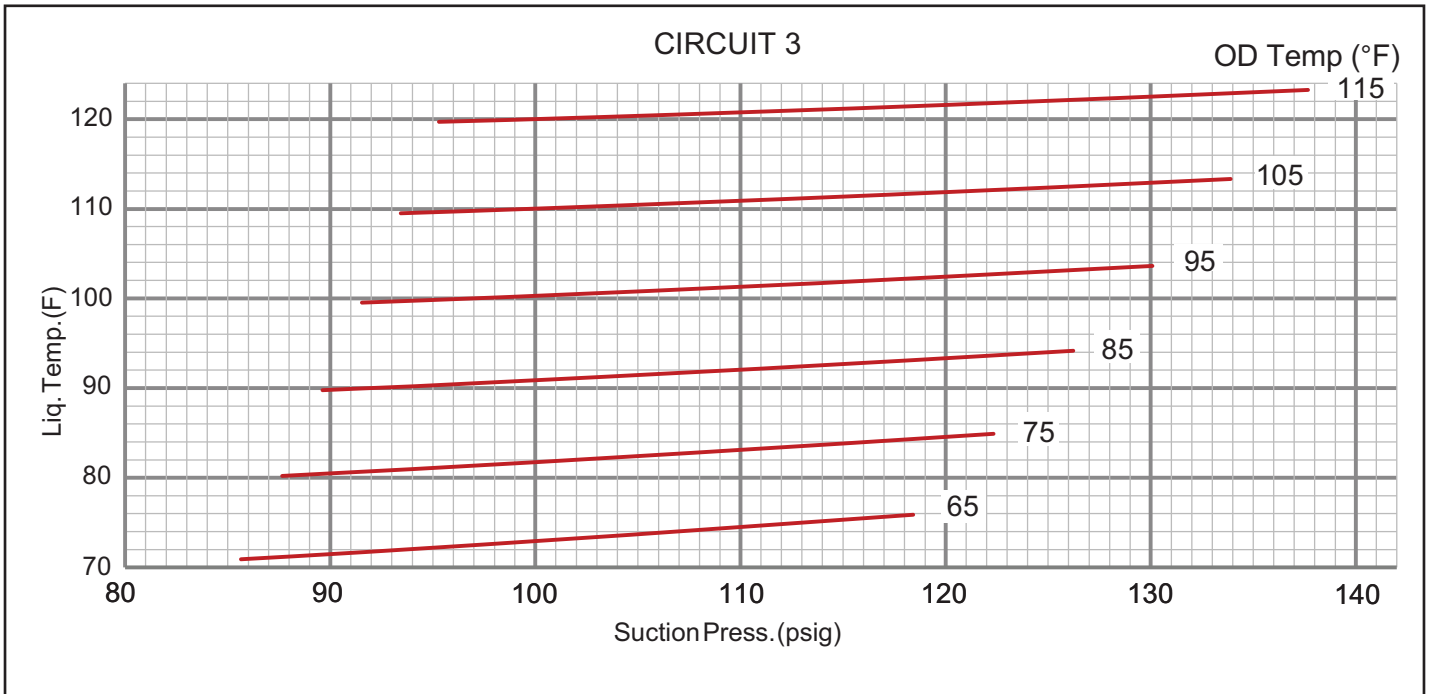

LGT/LCT 300 NO REHEAT CHARGING CURVE CIRCUIT 4 - ALL-ALUMINUM OD COIL - 581098-02

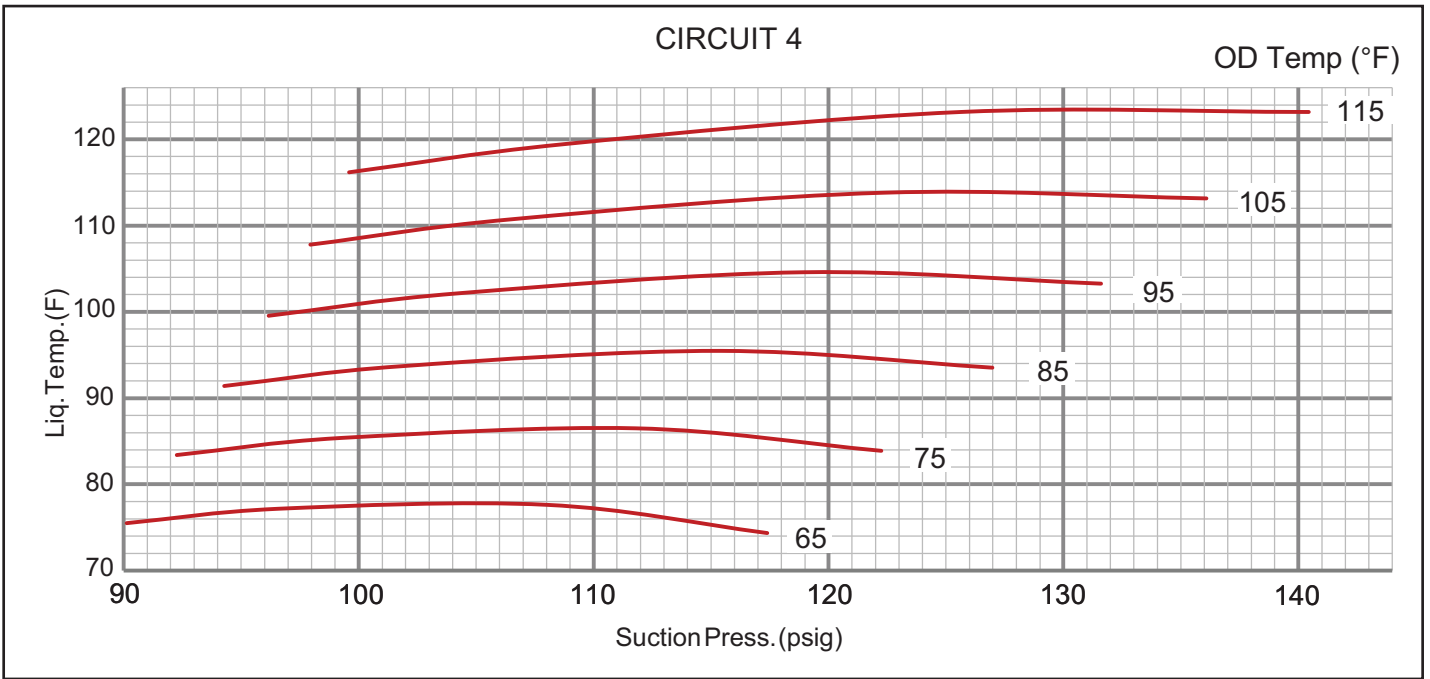
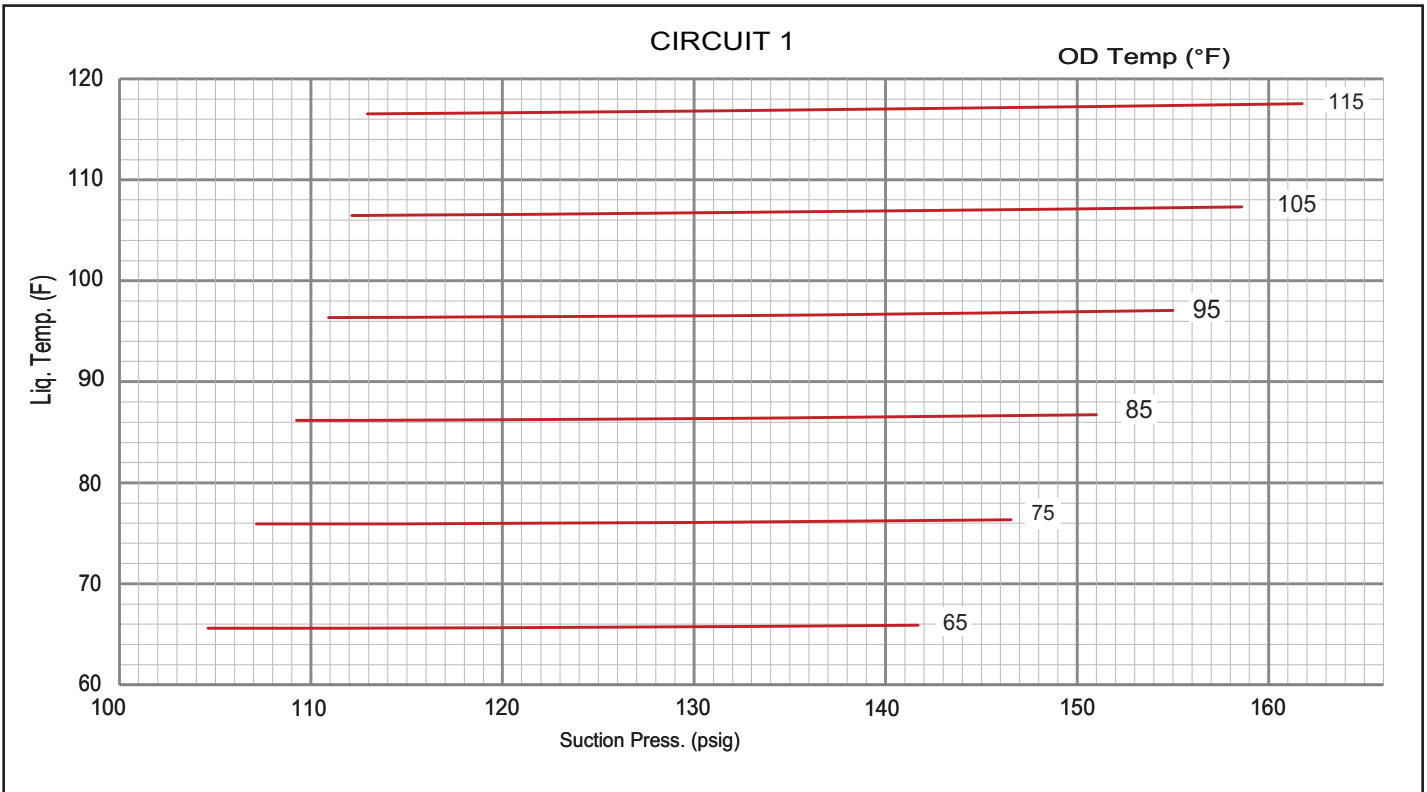

TABLE 10
LGT/LCT 156 REHEAT OPERATING PRESSURES - ALL-ALUMINUM OD COIL - 581083-02

Outdoor Coil Entering Air Temperature												
	65°F		75°F		85°F		95°F		105°F		115°F	
	Suct (psig)	Disc (psig)	Suct (psig)	Disc (psig)	Suct (psig)	Disc (psig)	Suct (psig)	Disc (psig)	Suct (psig)	Disc (psig)	Suct (psig)	Disc (psig)
Circuit 1	105	230	107	266	109	308	111	356	112	410	113	469
	112	233	115	268	117	310	119	357	121	410	122	469
	126	240	130	275	134	315	136	363	140	413	142	471
	142	250	147	284	151	323	155	368	159	419	162	475
Circuit 2	102	230	105	267	107	309	108	356	109	408	108	464
	108	233	112	270	114	312	117	359	118	411	119	468
	119	240	124	277	129	320	134	360	137	419	139	475
	130	247	138	285	144	328	150	375	155	427	160	484

LGT/LCT 156 REHEAT CHARGING CURVE CIRCUIT 1 - ALL-ALUMINUM OD COIL - 581084-02



LGT/LCT 156 REHEAT CHARGING CURVE CIRCUIT 2 - ALL-ALUMINUM OD COIL - 581084-02

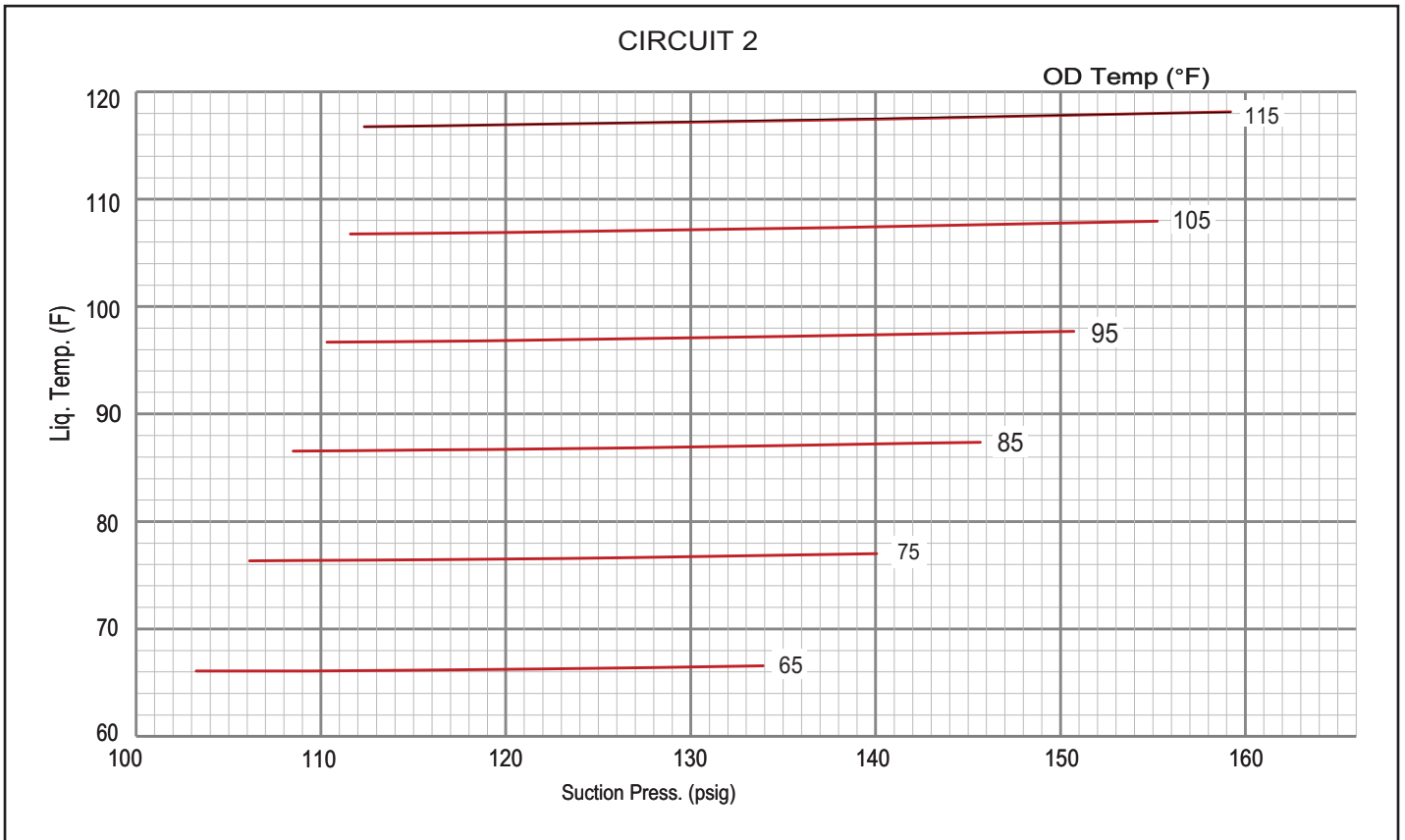
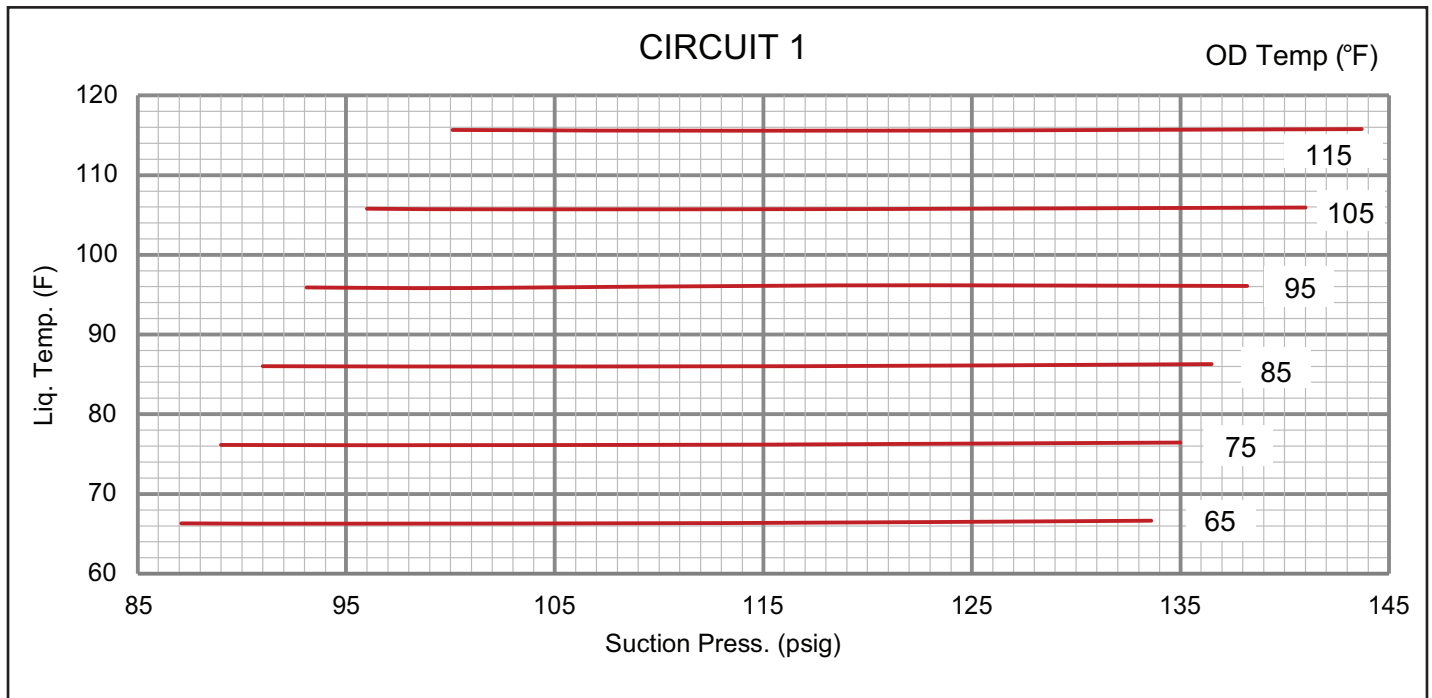

TABLE 11
LGT/LCT 180 REHEAT OPERATING PRESSURES - ALL-ALUMINUM OD COIL - 581361-01

Outdoor Coil Entering Air Temperature												
	65°F		75°F		85°F		95°F		105°F		115°F	
	Suct (psig)	Disc (psig)	Suct (psig)	Disc (psig)	Suct (psig)	Disc (psig)	Suct (psig)	Disc (psig)	Suct (psig)	Disc (psig)	Suct (psig)	Disc (psig)
Circuit 1	87	223	89	262	91	309	93	364	96	421	100	522
	95	223	96	262	98	309	101	361	103	418	107	503
	113	226	115	265	117	312	119	355	121	412	124	479
	134	230	135	269	137	316	138	352	141	409	144	466
Circuit 2	103	236	104	275	105	322	107	378	109	435	111	536
	113	239	114	278	115	325	116	375	118	432	119	525
	132	246	133	285	134	332	136	377	138	434	139	504
	150	254	152	293	155	340	157	385	160	442	162	496
Circuit 3	94	228	96	267	98	314	100	352	102	409	105	457
	103	231	105	270	106	317	108	350	110	407	113	462
	120	242	122	281	124	328	127	363	128	420	131	470
	135	246	138	285	141	332	146	371	149	428	152	477

LGT/LCT 180 REHEAT CHARGING CURVE CIRCUIT 1 - ALL-ALUMINUM OD COIL - 581362-01



LGT/LCT 180 REHEAT CHARGING CURVE CIRCUIT 2 - ALL-ALUMINUM OD COIL - 581362-01

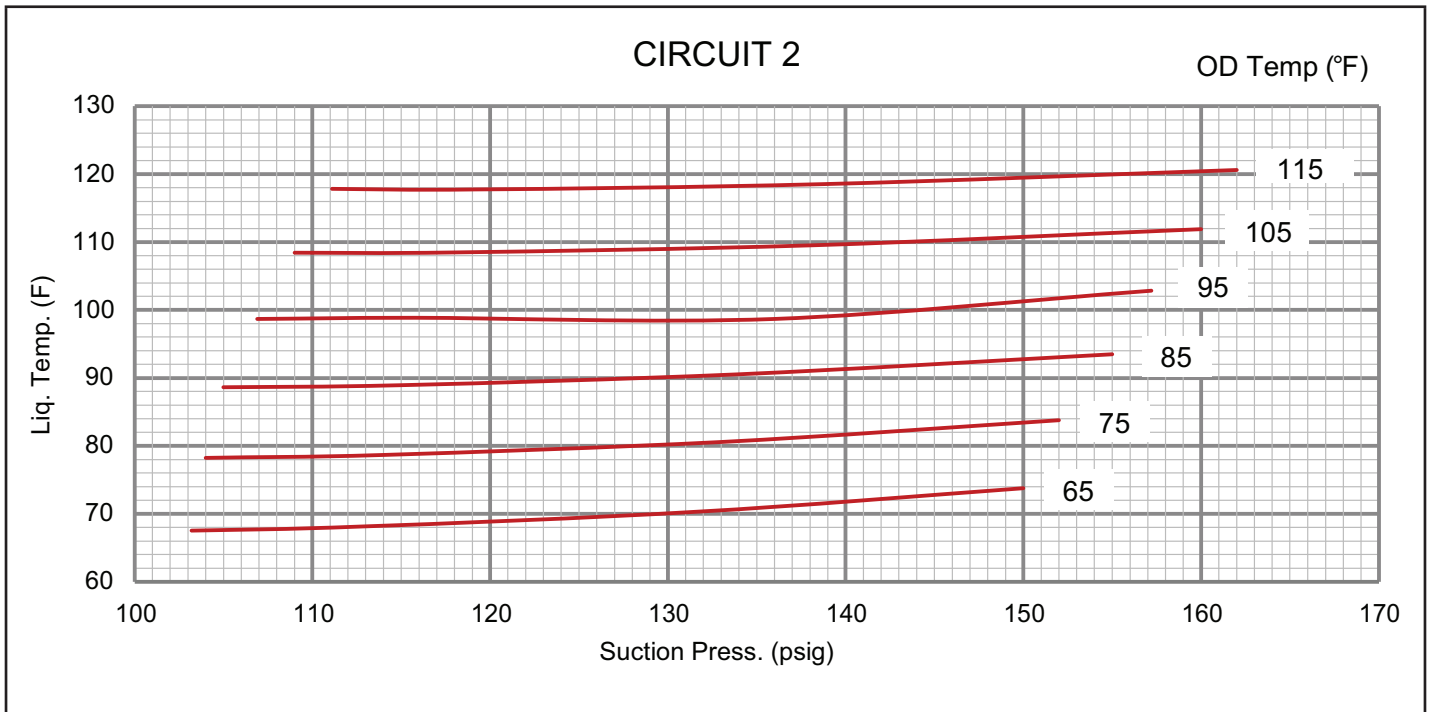

LGT/LCT 180 REHEAT CHARGING CURVE CIRCUIT 3 - ALL-ALUMINUM OD COIL - 581362-01

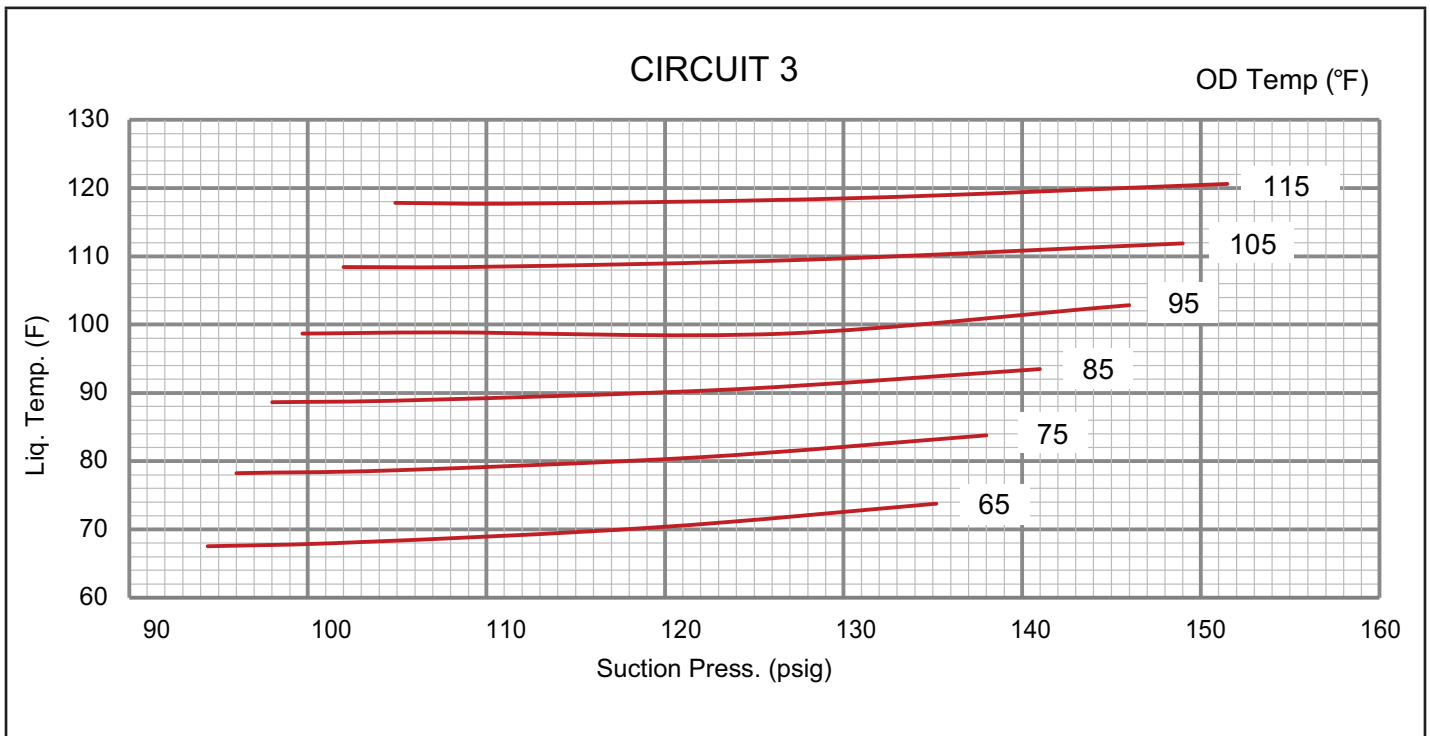
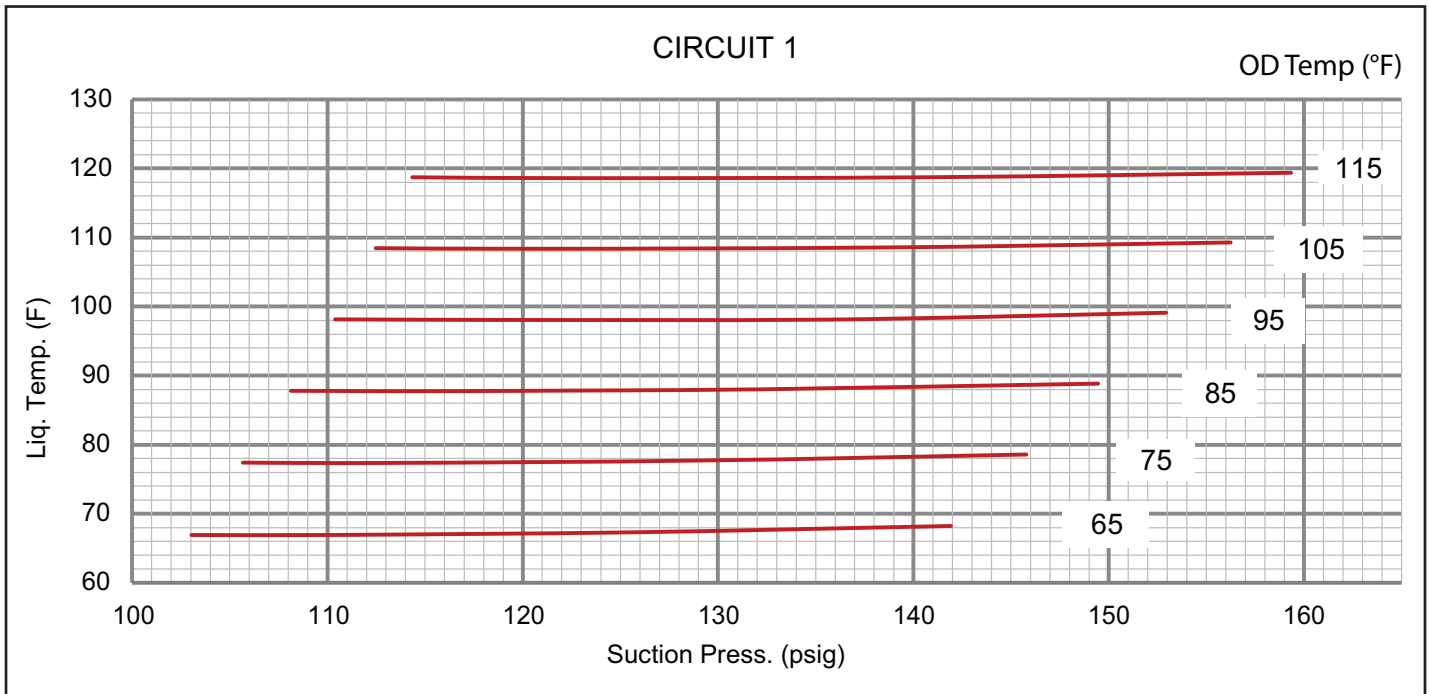

TABLE 12
LGT/LCT 210 REHEAT NORMAL OPERATING PRESSURES - ALL-ALUMINUM OD COIL - 581091-02

Outdoor Coil Entering Air Temperature												
	65°F		75°F		85°F		95°F		105°F		115°F	
	Suct (psig)	Disc (psig)	Suct (psig)	Disc (psig)	Suct (psig)	Disc (psig)	Suct (psig)	Disc (psig)	Suct (psig)	Disc (psig)	Suct (psig)	Disc (psig)
Circuit 1	103	226	106	262	108	303	110	349	112	401	114	458
	110	230	113	266	116	307	118	353	121	405	123	462
	126	237	129	272	132	313	136	360	138	411	141	468
	142	242	146	277	149	318	153	364	156	416	159	473
Circuit 2	109	236	111	273	113	315	115	362	117	413	119	469
	117	239	119	276	121	318	124	365	126	417	128	473
	134	247	136	285	139	328	142	374	145	427	147	484
	151	258	154	297	158	340	161	388	164	441	168	498
Circuit 3	96	222	98	259	100	300	102	346	104	396	107	451
	103	224	105	261	107	303	110	349	112	400	115	455
	119	229	122	267	124	309	126	355	129	407	132	463
	137	235	140	273	142	316	145	364	148	416	151	473
Circuit 4	99	223	101	260	103	303	105	350	108	402	110	459
	106	226	108	263	111	306	113	353	116	406	118	463
	121	231	124	270	127	313	130	359	133	414	136	472
	138	237	141	276	145	320	148	369	151	423	154	481

LGT/LCT 210 REHEAT CHARGING CURVE CIRCUIT 1 - ALL-ALUMINUM OD COIL - 581092-02



LGT/LCT 210 REHEAT CHARGING CURVE CIRCUIT 2 - ALL-ALUMINUM OD COIL - 581092-02

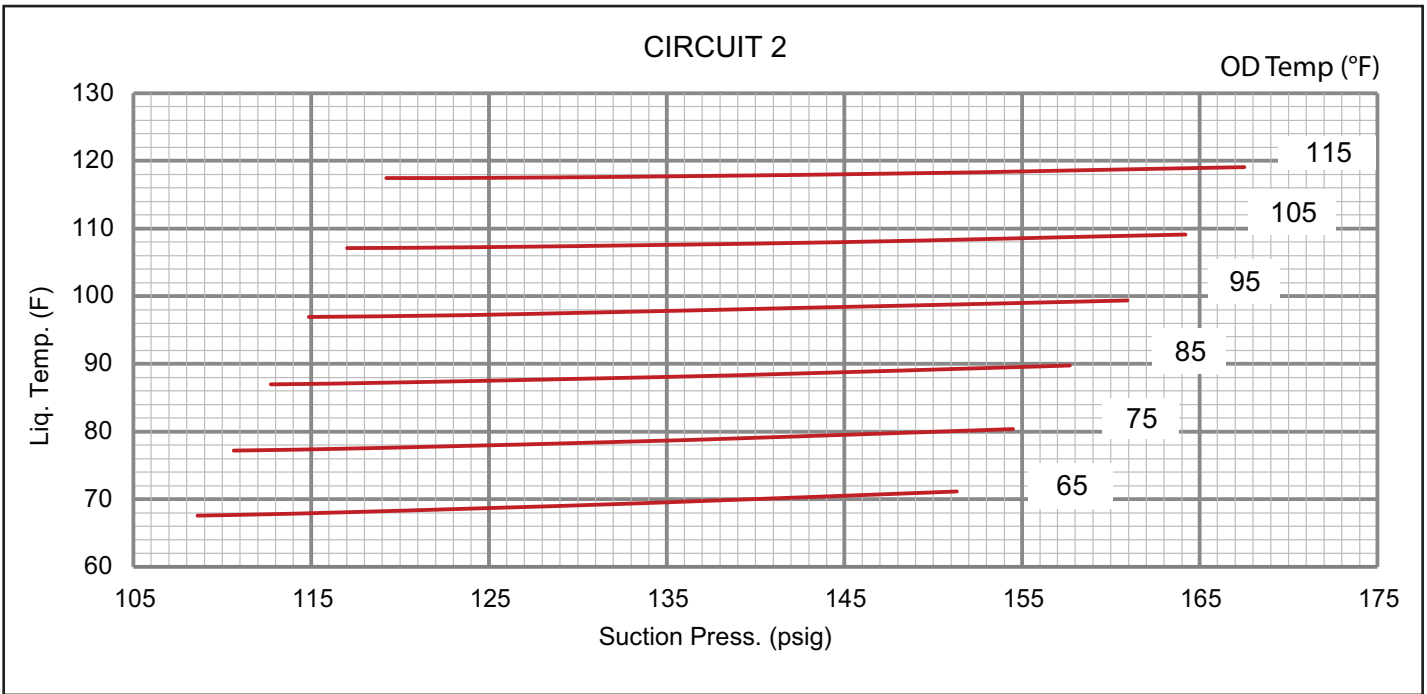

LGT/LCT 210 REHEAT CHARGING CURVE CIRCUIT 3 - ALL-ALUMINUM OD COIL - 581092-02

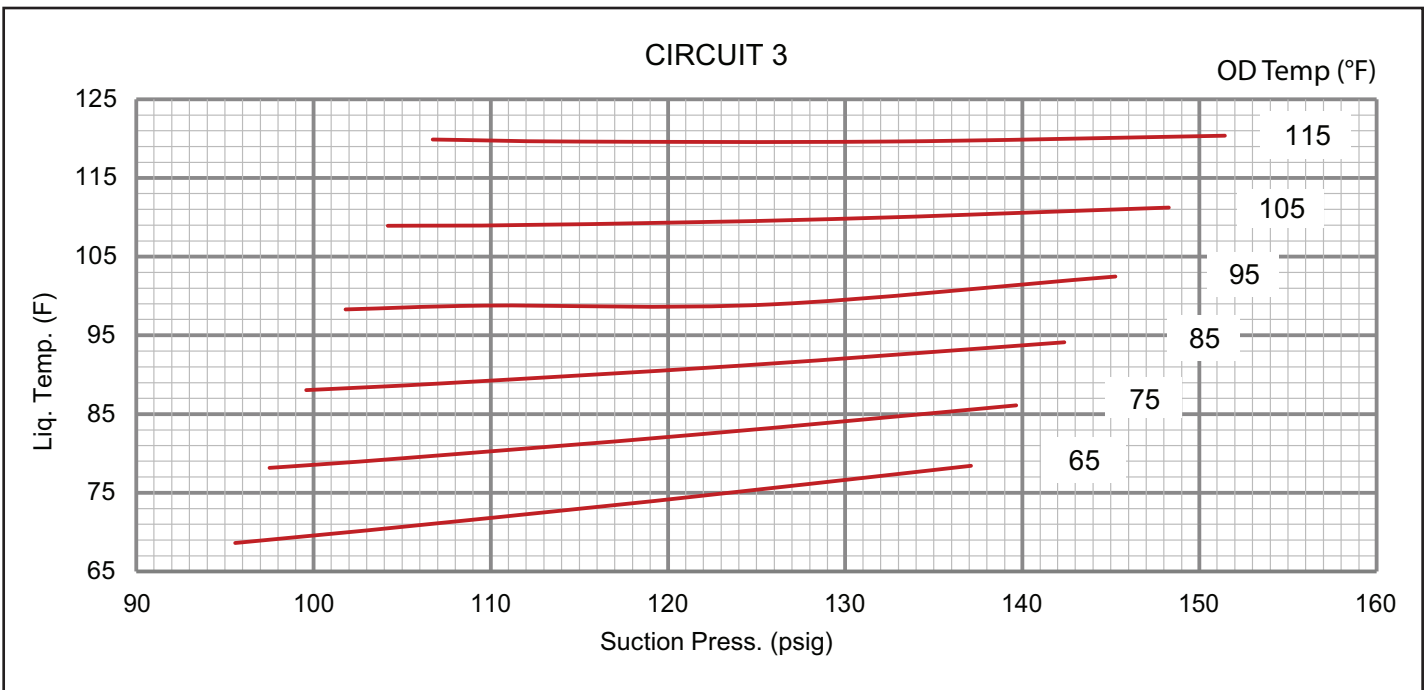

LGT/LCT 210 REHEAT CHARGING CURVE CIRCUIT 4 - ALL-ALUMINUM OD COIL - 581092-02

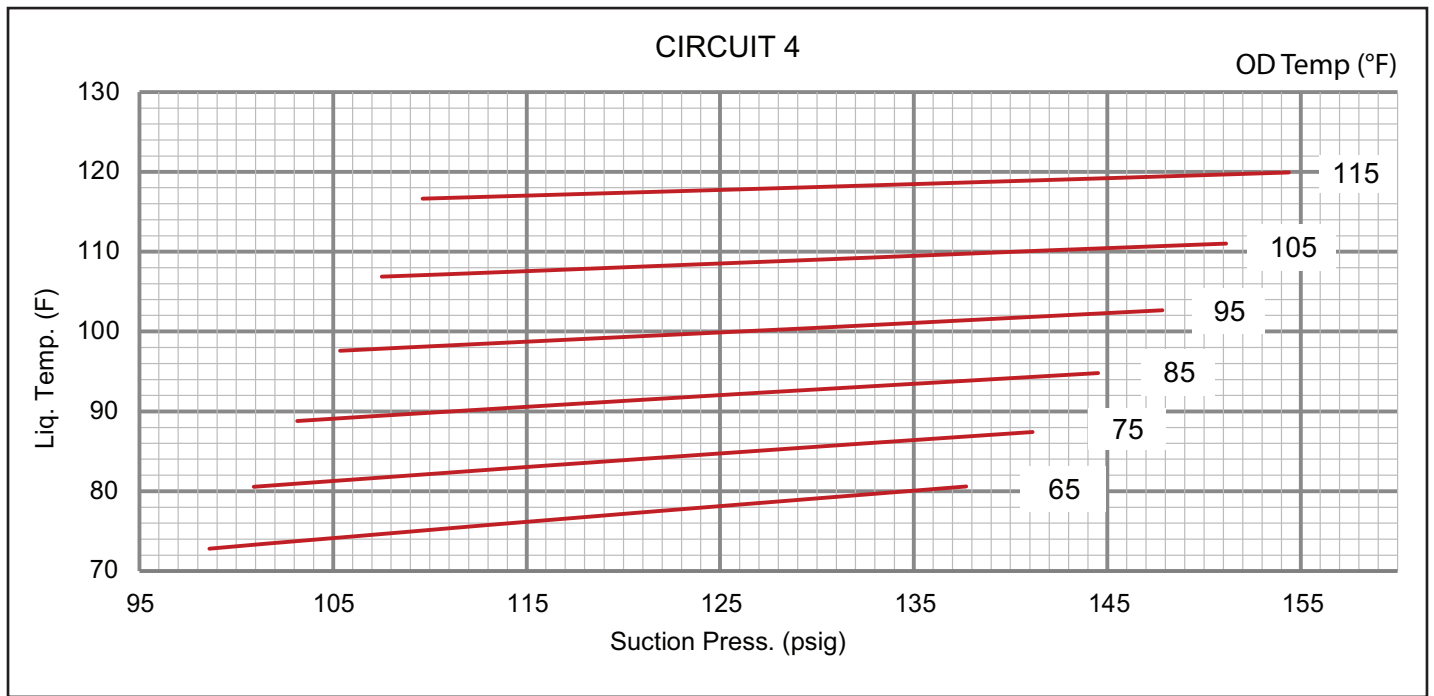
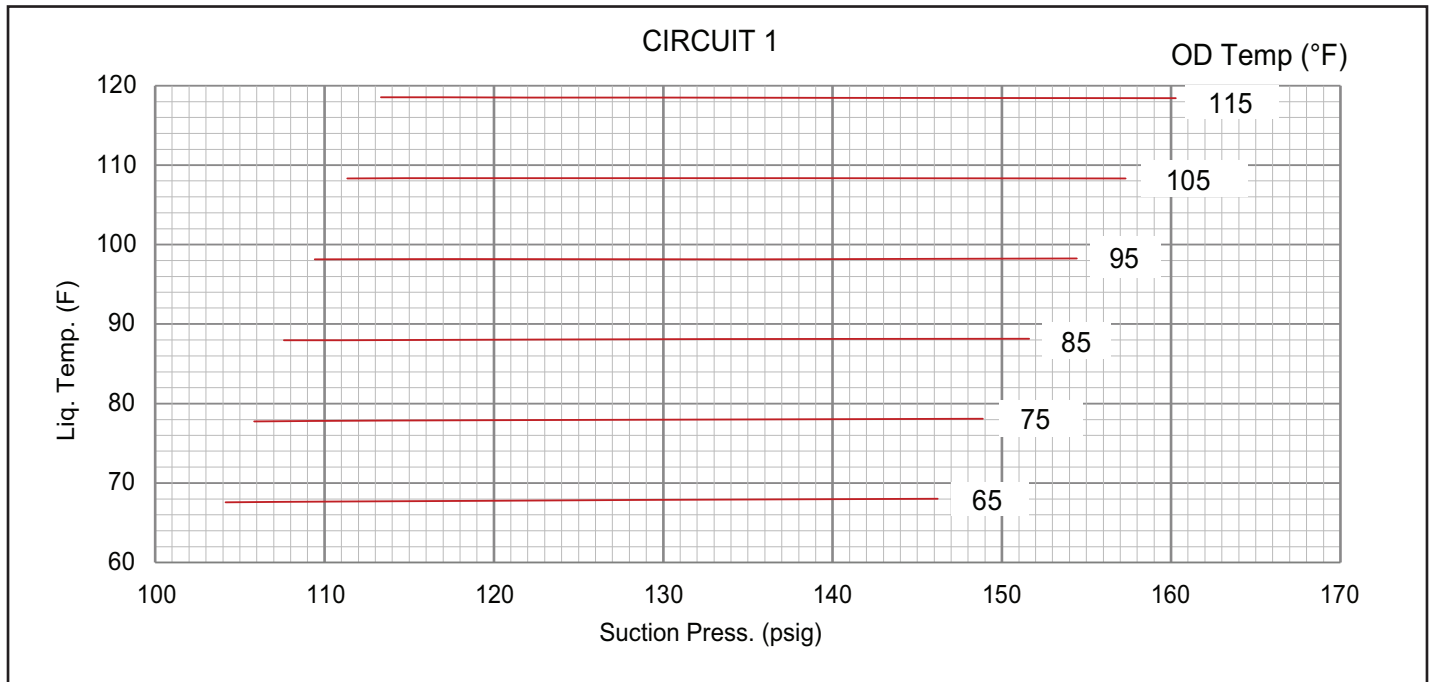

TABLE 13
LGT/LCT 240 REHEAT NORMAL OPERATING PRESSURES - ALL-ALUMINUM OD COIL - 581095-02

Outdoor Coil Entering Air Temperature												
	65°F		75°F		85°F		95°F		105°F		115°F	
	Suct (psig)	Disc (psig)	Suct (psig)	Disc (psig)	Suct (psig)	Disc (psig)	Suct (psig)	Disc (psig)	Suct (psig)	Disc (psig)	Suct (psig)	Disc (psig)
Circuit 1	104	234	106	268	108	312	109	365	111	428	113	500
	112	241	114	274	116	317	118	370	120	432	122	503
	128	252	131	285	133	326	135	377	138	438	140	508
	146	262	149	293	152	333	154	383	157	442	160	511
Circuit 2	104	242	105	282	107	331	109	388	111	456	114	532
	112	248	114	287	115	335	117	392	120	458	122	534
	130	258	132	295	134	341	136	394	138	462	141	536
	151	264	153	300	155	345	157	399	160	462	163	535
Circuit 3	91	223	93	259	95	300	97	346	99	396	101	450
	98	225	100	261	103	302	105	348	107	398	110	453
	114	229	117	266	120	308	122	354	125	404	128	459
	132	235	135	272	138	314	141	360	144	411	147	466
Circuit 4	93	226	95	264	96	306	98	352	100	403	101	458
	100	229	102	267	104	309	107	355	109	406	111	461
	115	235	118	273	121	315	125	362	127	412	130	468
	132	242	135	280	139	323	143	369	147	420	151	476

LGT/LCT 240 REHEAT CHARGING CURVE CIRCUIT 1 - ALL-ALUMINUM OD COIL - 581096-02



LGT/LCT 240 REHEAT CHARGING CURVE CIRCUIT 2 - ALL-ALUMINUM OD COIL - 581096-02

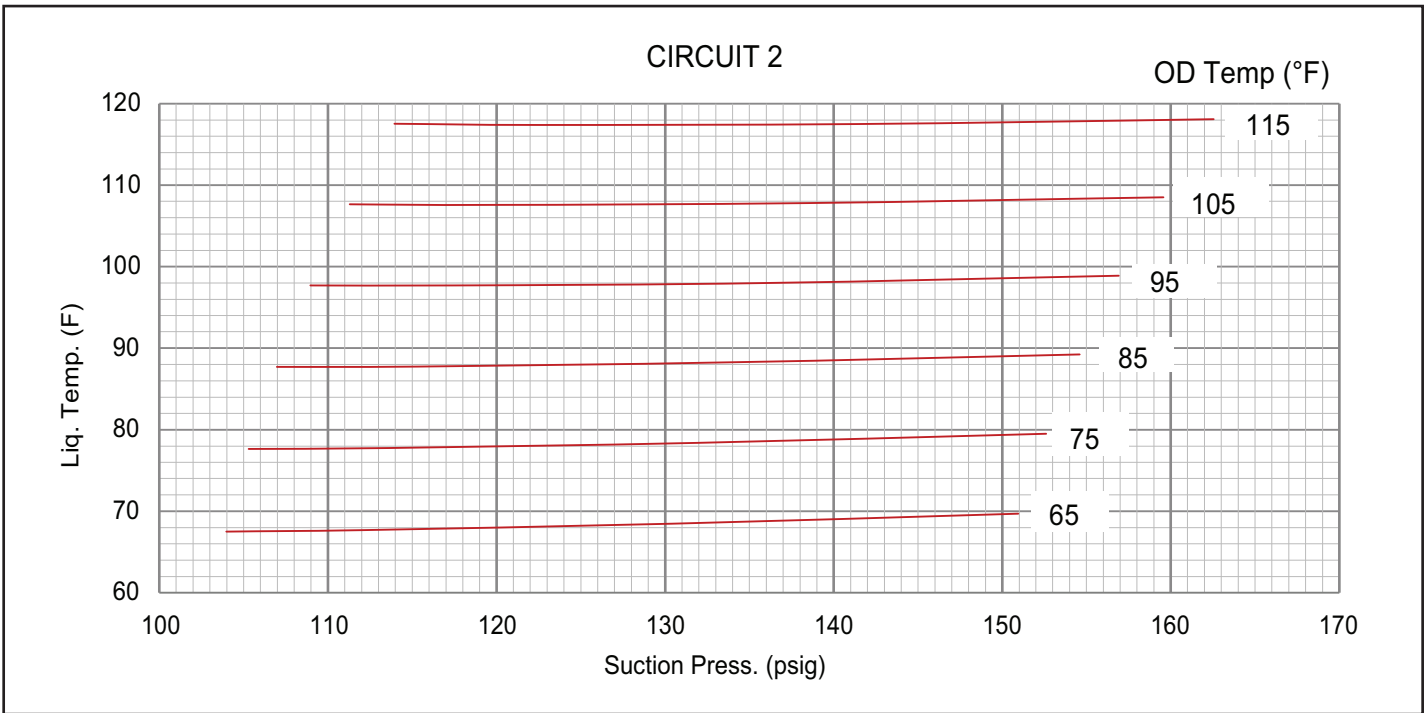

LGT/LCT 240 REHEAT CHARGING CURVE CIRCUIT 3 - ALL-ALUMINUM OD COIL - 581096-02

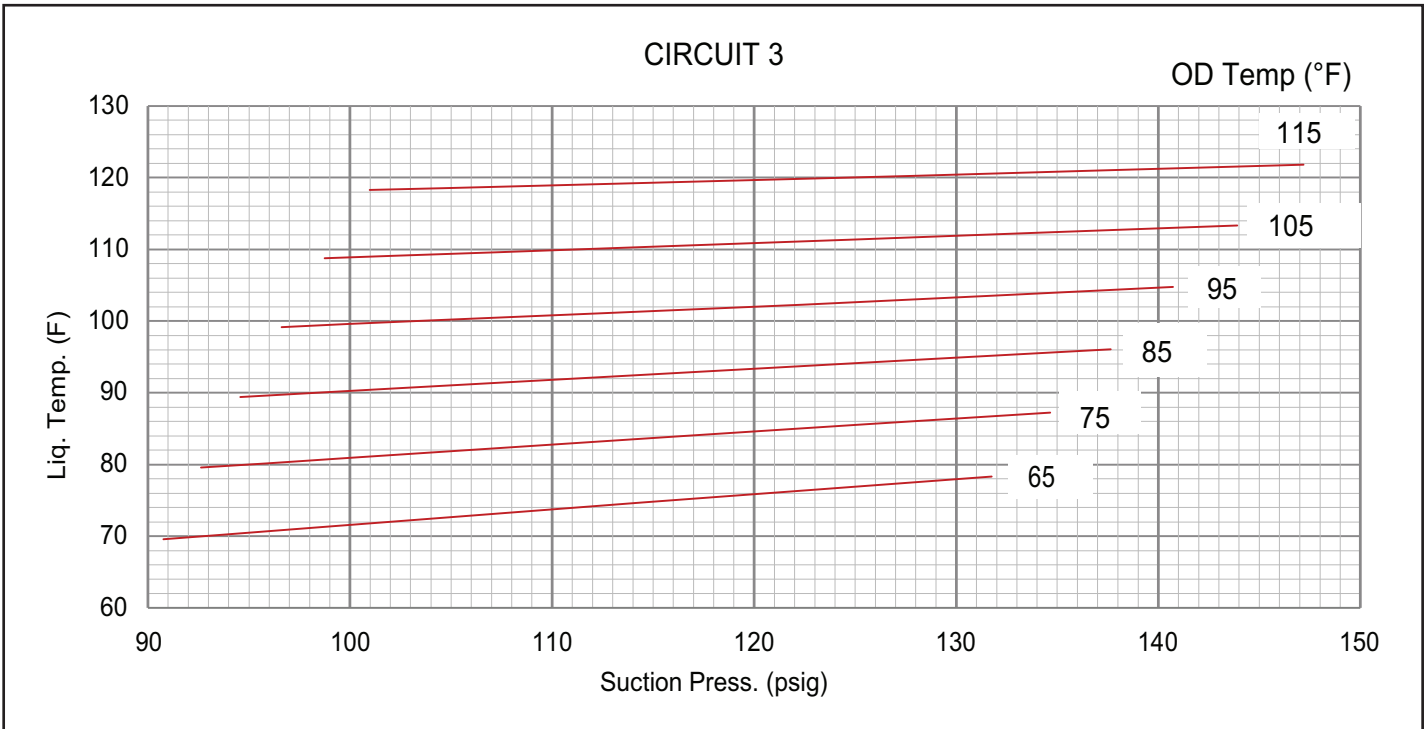

LGT/LCT 240 REHEAT CHARGING CURVE CIRCUIT 4 - ALL-ALUMINUM OD COIL - 581096-02

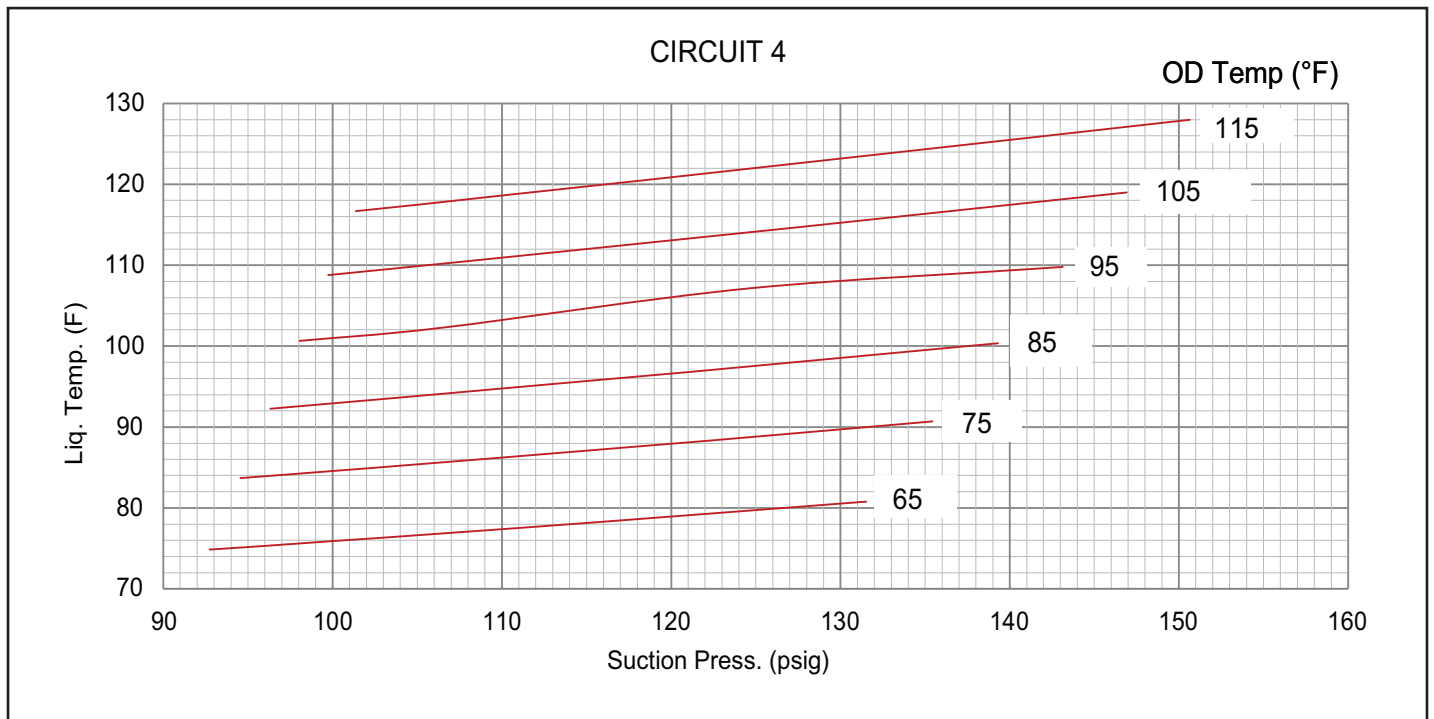
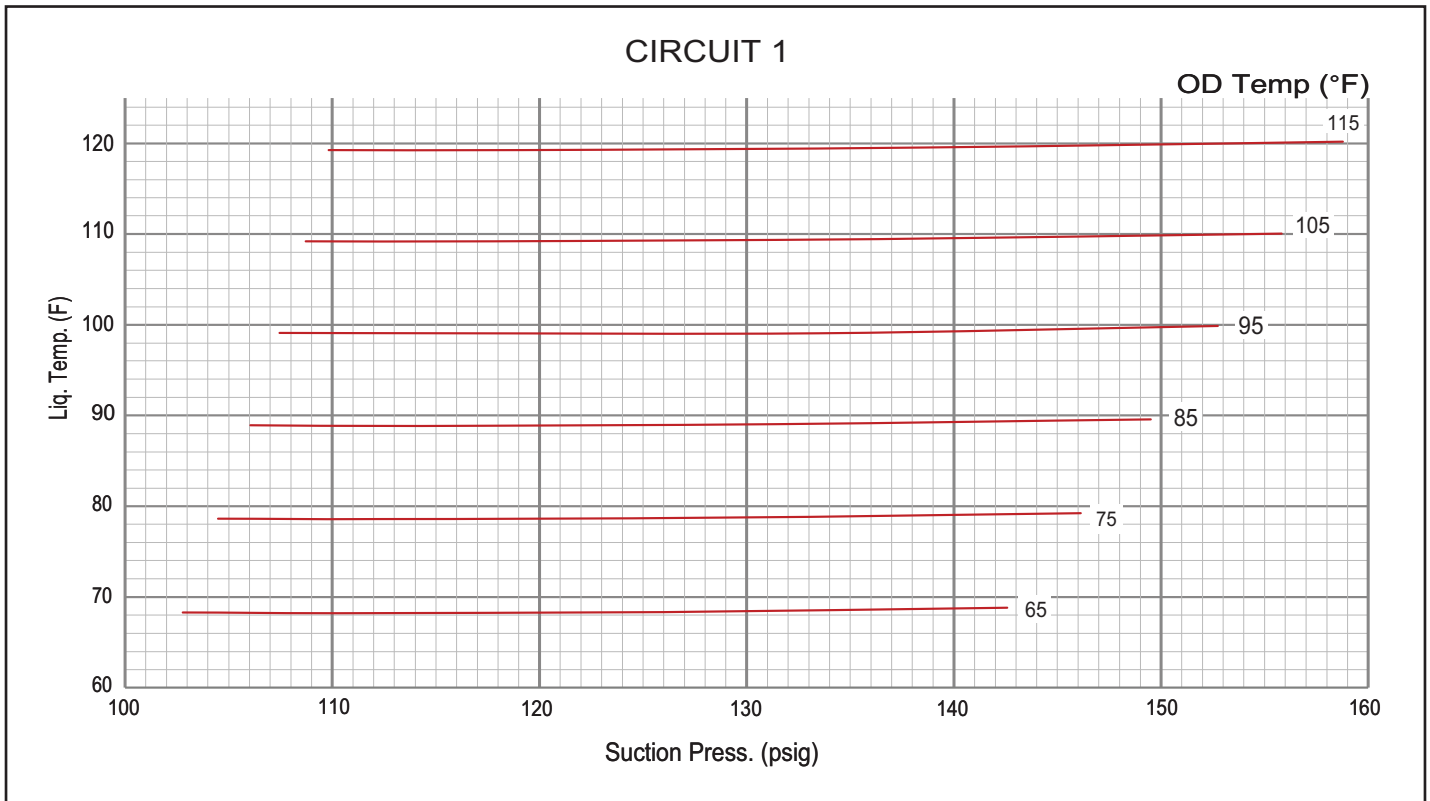

TABLE 14
LGT/LCT 300 REHEAT NORMAL OPERATING PRESSURES - ALL-ALUMINUM OD COIL - 581099-02

Outdoor Coil Entering Air Temperature												
	65°F		75°F		85°F		95°F		105°F		115°F	
	Suct (psig)	Disc (psig)	Suct (psig)	Disc (psig)	Suct (psig)	Disc (psig)	Suct (psig)	Disc (psig)	Suct (psig)	Disc (psig)	Suct (psig)	Disc (psig)
Circuit 1	103	244	104	277	106	321	107	373	109	435	110	507
	110	255	112	288	114	331	116	383	118	445	119	516
	126	268	129	301	131	344	133	389	136	457	139	527
	143	270	146	303	150	344	153	396	156	456	159	526
Circuit 2	103	252	104	291	105	333	106	381	108	433	109	489
	111	257	112	295	114	338	115	386	117	438	118	494
	127	267	129	306	132	349	134	394	136	449	139	505
	144	278	148	317	151	361	154	408	157	461	160	517
Circuit 3	87	238	89	278	91	321	92	368	94	418	96	473
	94	240	96	279	98	323	100	370	102	421	104	475
	108	245	111	285	114	328	117	373	120	427	123	483
	123	253	126	293	130	337	134	385	138	437	142	493
Circuit 4	90	245	92	285	94	330	95	377	97	429	98	484
	96	246	99	287	102	332	104	380	105	431	107	486
	110	253	114	294	117	339	120	385	124	440	126	495
	124	263	129	305	134	350	138	399	142	452	146	508

LGT/LCT 300 REHEAT CHARGING CURVE CIRCUIT 1 - ALL-ALUMINUM OD COIL - 581100-02



LGT/LCT 300 REHEAT CHARGING CURVE CIRCUIT 2 - ALL-ALUMINUM OD COIL - 581100-02

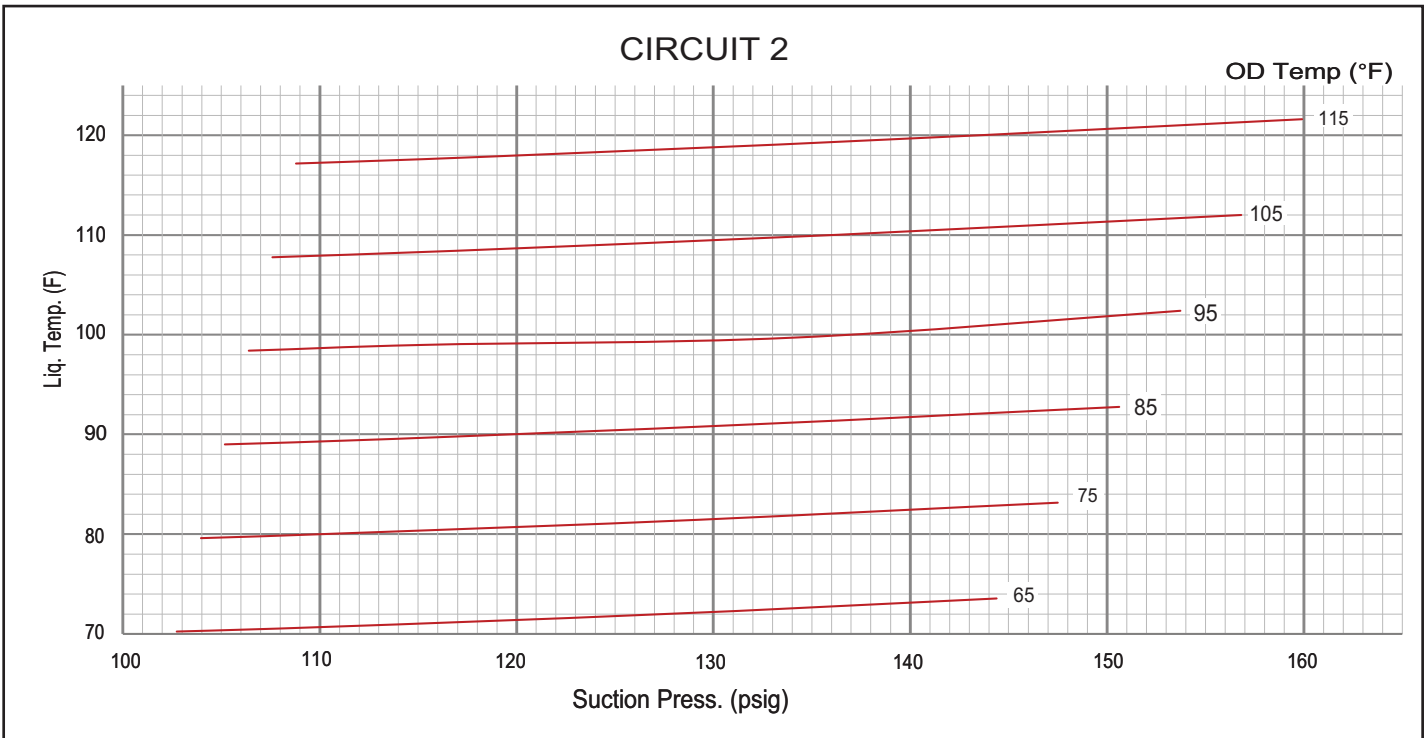

LGT/LCT 300 REHEAT CHARGING CURVE CIRCUIT 3 - ALL-ALUMINUM OD COIL - 581100-02

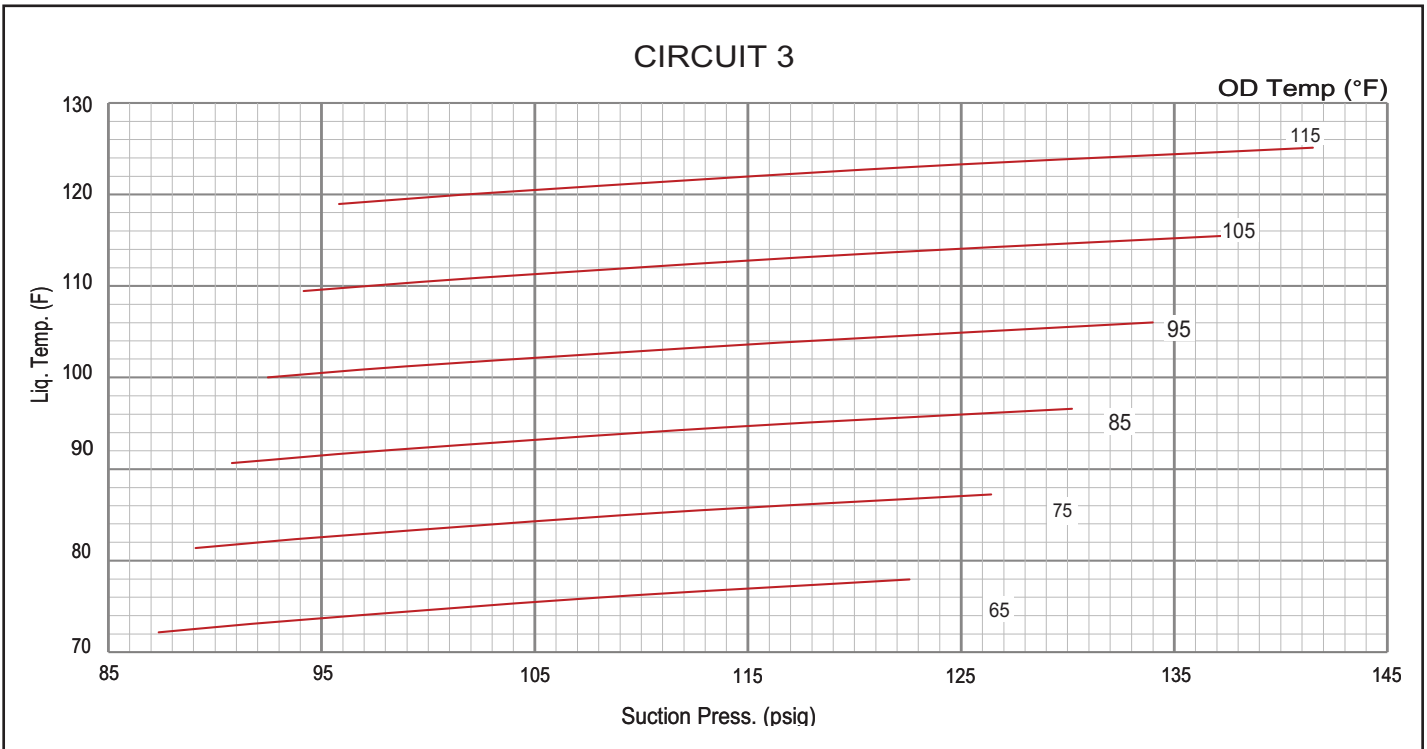

LGT/LCT 300 REHEAT CHARGING CURVE CIRCUIT 4 - ALL-ALUMINUM OD COIL - 581100-02

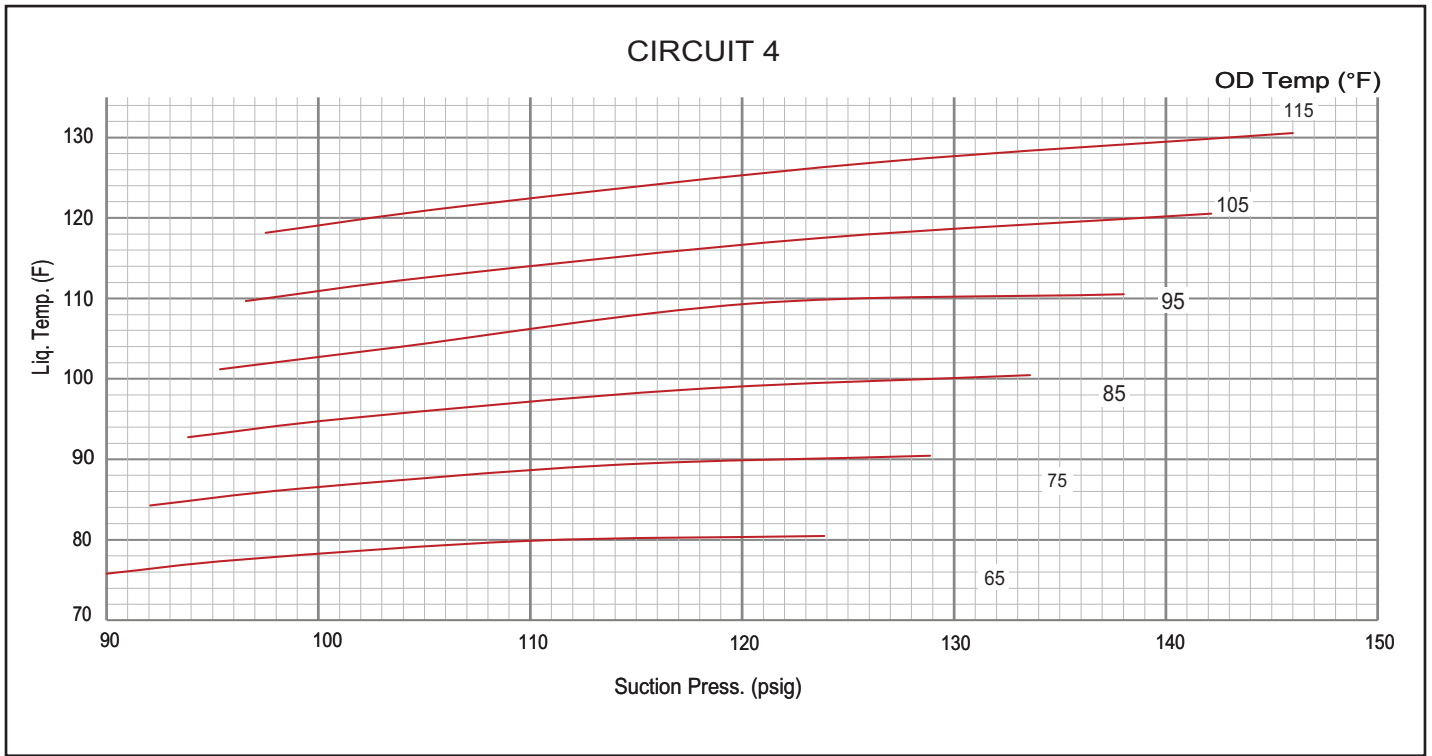

F-Compressor Controls

See unit wiring diagram to determine which controls are used on each unit.

1 - High Pressure Switch (S4, S7, S28, S96)

The compressor circuit is protected by a high pressure switch which opens at 640 psig \pm 10 psig (4413 kPa \pm 70 kPa) and automatically resets at 475 psig \pm 20 psig (3275kPa \pm 138 kPa).

2 - Low Pressure Switch (S87, S88, S97, S98)

The compressor circuit is protected by a low pressure switch. Switch opens at 40 psig \pm 5 psig (276 \pm 34 kPa) and automatically resets at 90 psig \pm 5 psig (621 kPa \pm 34 kPa).

3 - Crankcase Heater (HR1, HR2, HR5, HR11)

Units have compressors which contain a belly band compressor oil heater which must be on 24 hours before running compressors. Energize by setting thermostat so that there is no cooling demand, to prevent compressor from cycling, and apply power to unit.

4 - Thermal Protector (S5)

Each fixed-speed compressor is protected by an internal thermal protector switch.

5 - Condenser Fan Operation

156

Condenser fan 1, 2, and 3 are energized when compressor 1 or 2 are energized. See FIGURE 27.

Condenser fans 1 and 2 are de-energized when outdoor temperature drops below 62°F (17°C).

Condenser fan 3 modulates to maintain target liquid temperatures when outdoor temperature drops below 62°F (17°C).

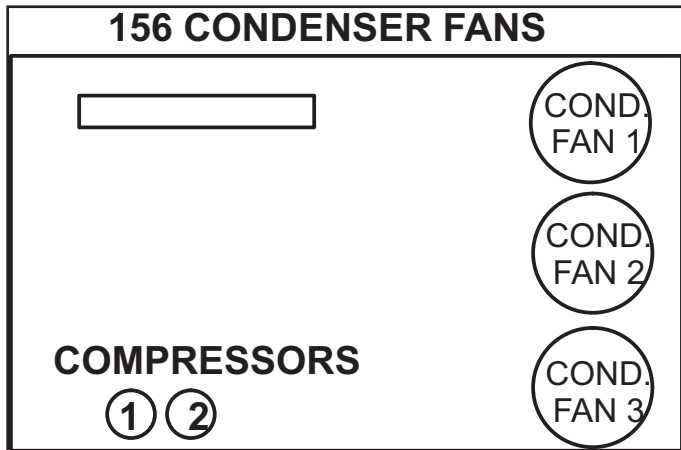

FIGURE 27

180

Condenser fan 3 and 4 are energized when compressor 1 is the ONLY compressor energized. As cooling demand increases, all four condenser fans are energized. See FIGURE 28.

Condenser fans 1 and 3 are de-energized when outdoor temperature drops below 62°F (17°C).

Condenser fans 2 & 4 modulate to maintain target liquid temperatures when outdoor temperature drops below 62°F (17°C).

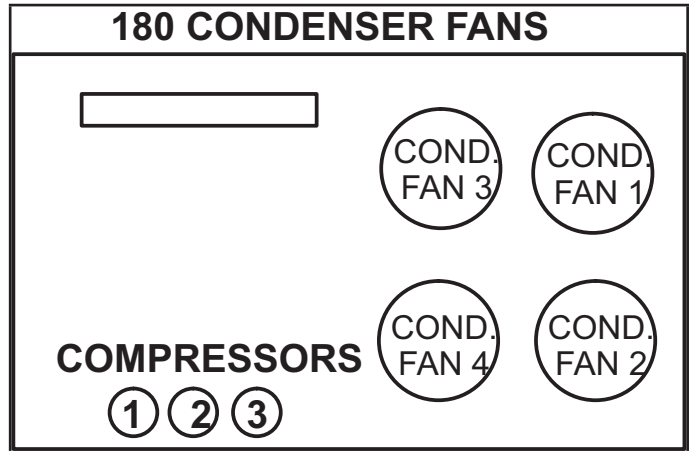

FIGURE 28

210

Condenser fans 1 and 2 are energized when compressor 1 or 2 are energized. As cooling demand increases, all four condenser fans are energized. See FIGURE 29.

Condenser fans 1 and 3 are de-energized when outdoor temperature drops below 62°F (17°C).

Condenser fans 2 & 4 modulate to maintain target liquid temperatures when outdoor temperature drops below 62°F (17°C).

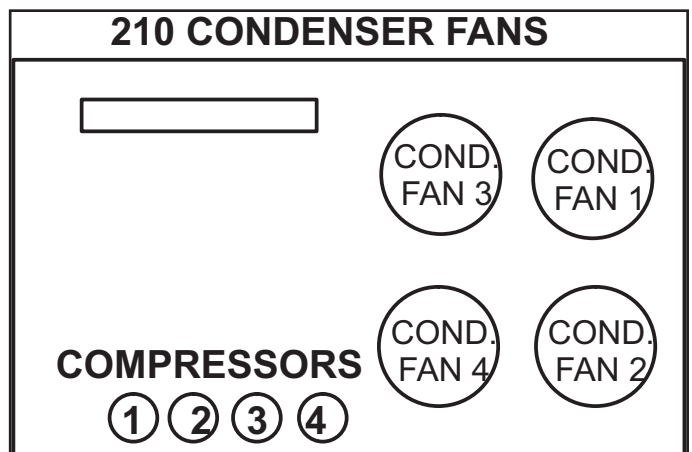

FIGURE 29

240 & 300

Condenser fans 1, 2, and 3 are energized when compressor 1 or 2 are energized. As cooling demand increases, all six condenser fans are energized. See FIGURE 30.

Condenser fans 1, 2, 4, and 5 are de-energized when outdoor temperature drops below 62°F (17°C).

Condenser fans 3 & 6 modulate to maintain target liquid temperatures when outdoor temperature drops below 62°F (17°C).

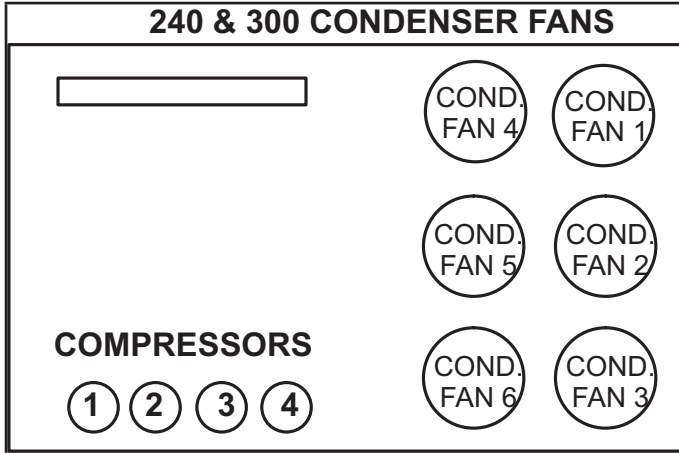

FIGURE 30

Diagnostic Sensors

Temperature thermistor sensors (RT46-53) are located on specific points for each refrigeration circuit. Temperature thermistors provide continuous temperature input to the unit controller for proper cooling operation as well as system protection. Controller logic will de-energize compressors for each refrigeration circuit when evaporator coil temperature falls below 32°F (0°C) to prevent evaporator freeze-up.

Each thermistor must be specifically placed for proper unit operation and to initiate valid alarms. See TABLE 15 through TABLE 17 for proper locations.

**TABLE 15
LGT/LCT156**

Cat. No.	Ass'y. No.	Sensor Yellow, Blue	Figure
22J06	623049-01	RT46, 47	FIGURE 31
23V50	623049-05	RT48, 49	FIGURE 32

**TABLE 16
LGT/LCT180**

Cat. No.	Ass'y. No.	Sensor Yellow, Blue, Red	Figure
22J06	623049-01	RT46, 47, 50	FIGURE 33
23V50	623049-05	RT48, 49, 52	FIGURE 34

**TABLE 17
LGT/LCT210, 240, 300**

Cat. No.	Ass'y. No.	Sensor Yel, Blu, Red, Grn	Figure
22J06	623049-01	RT46, 47, 50, 51	FIGURE 35
23V50	623049-05	RT48, 49, 52, 53	FIGURE 36

LGT/LCT56
EVAPORATOR / INDOOR COIL
(RT46, 47)

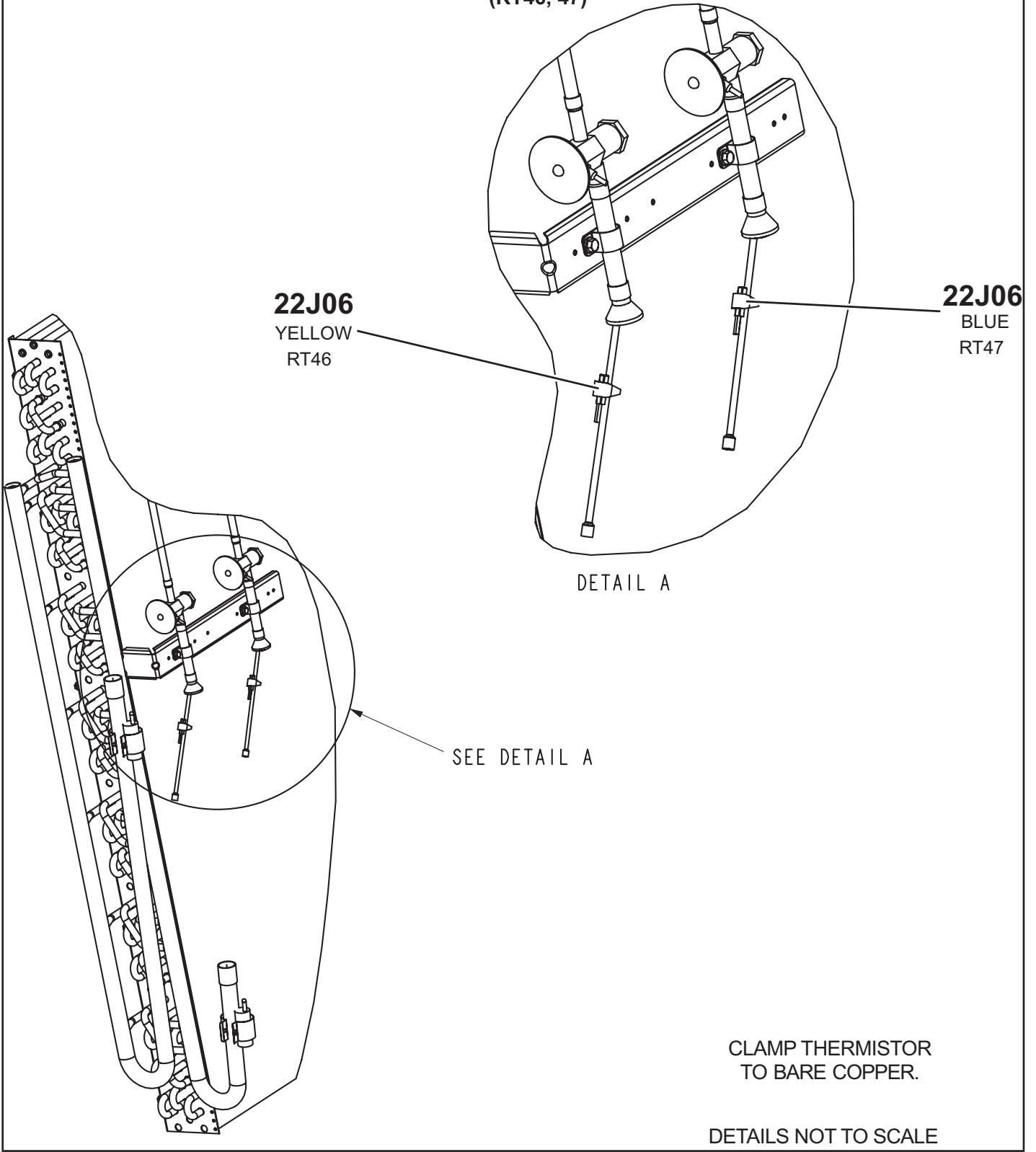
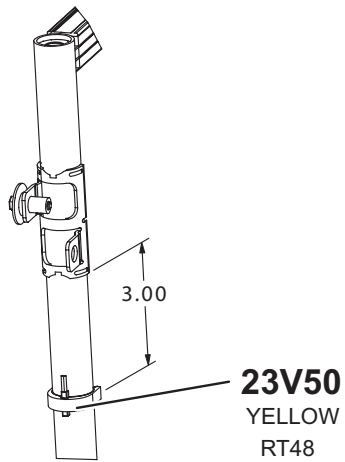
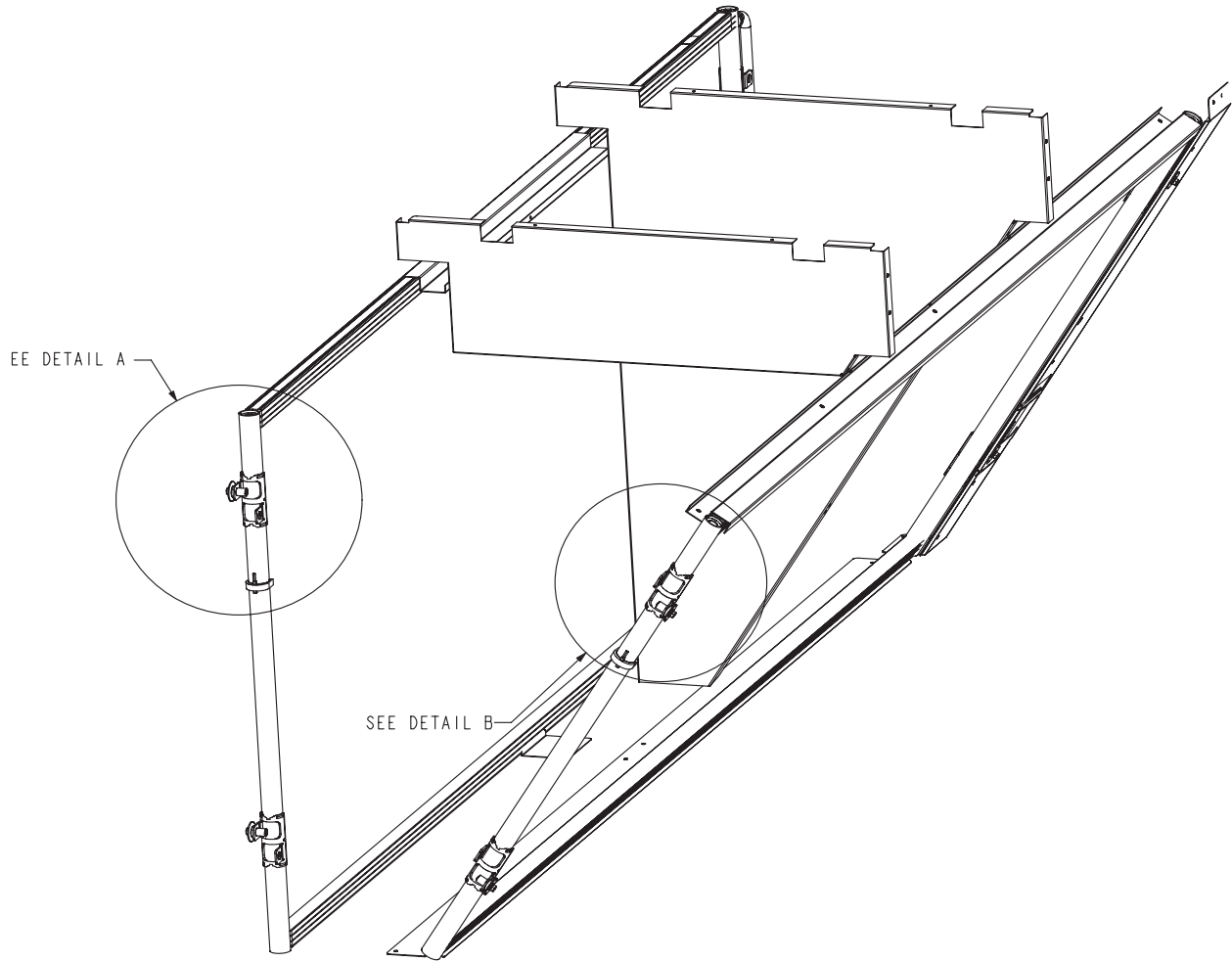

FIGURE 31

LGT/LCT156
CONDENSER / OUTDOOR COIL
(RT48, 49)



DETAIL A

23V50
BLUE
RT49

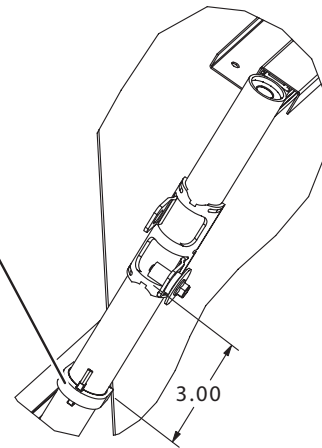

DETAIL B

CLAMP THERMISTOR
TO BARE COPPER.

DETAILS NOT TO SCALE

FIGURE 32

LGT/LCT180
EVAPORATOR / INDOOR COIL
RT46, 47, 50

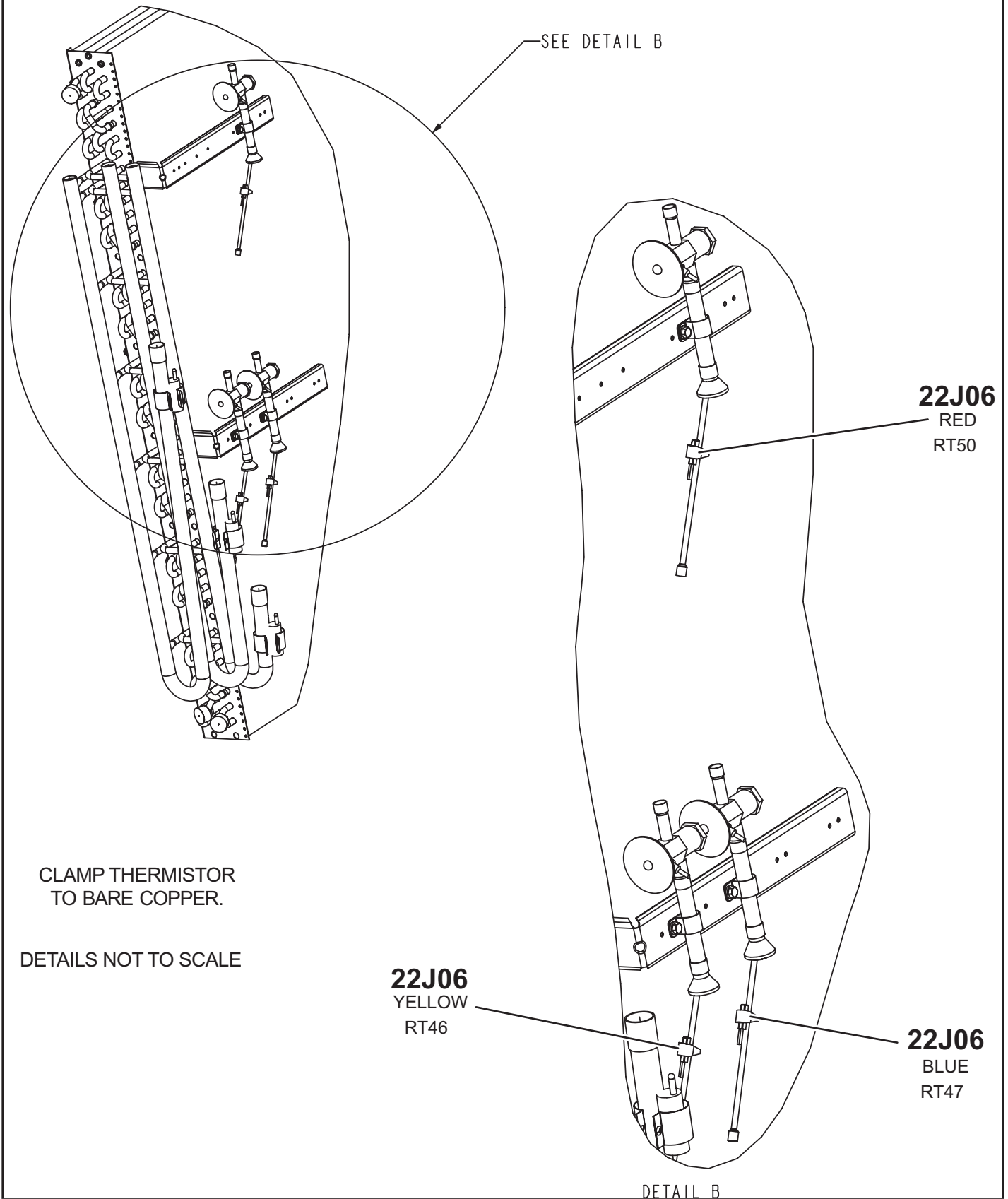
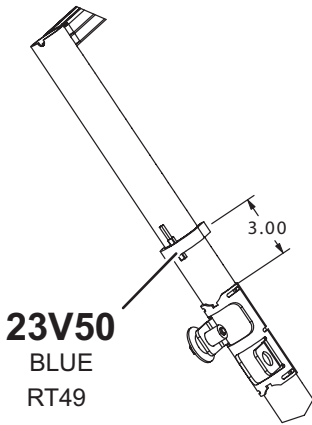
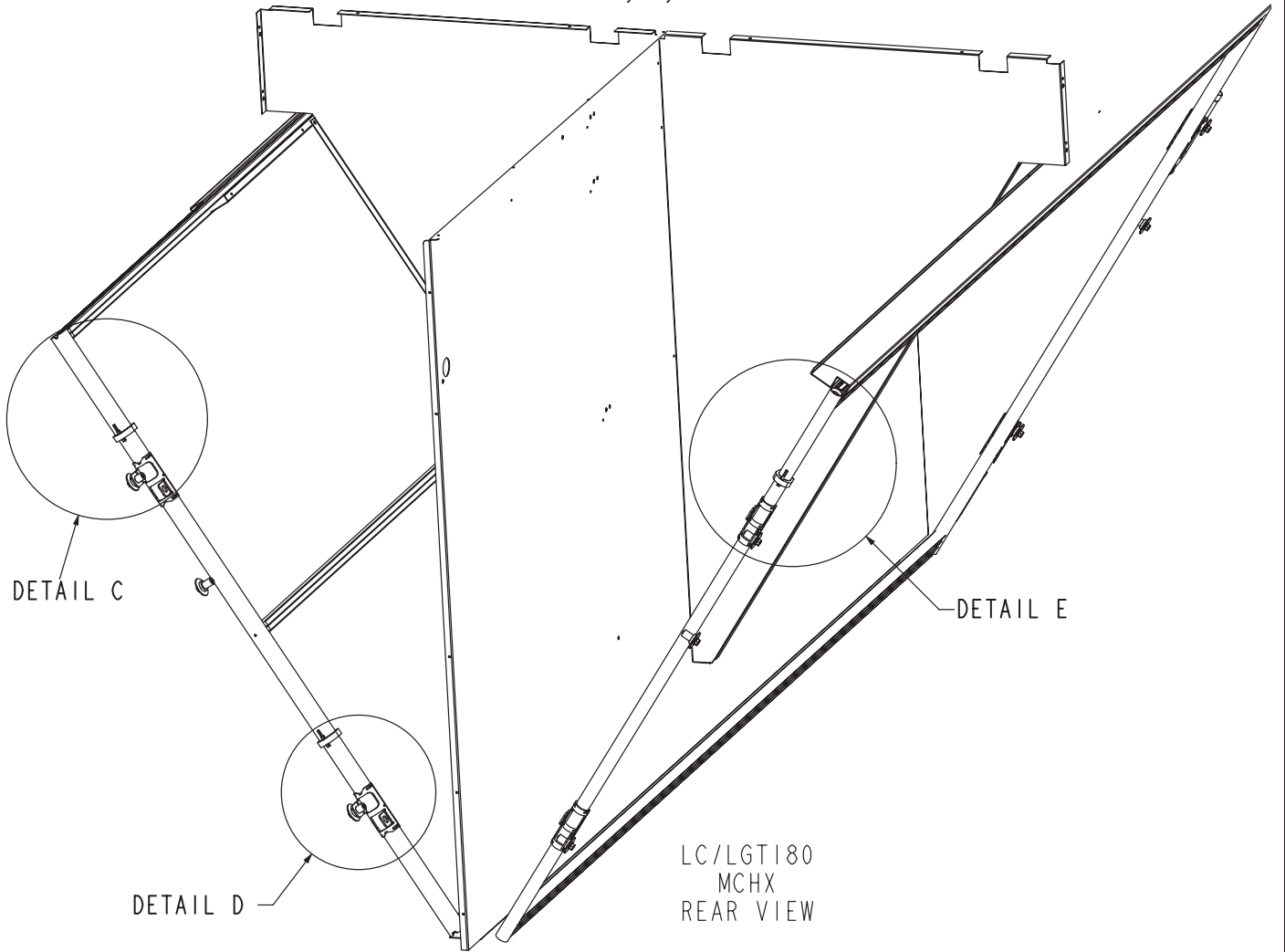
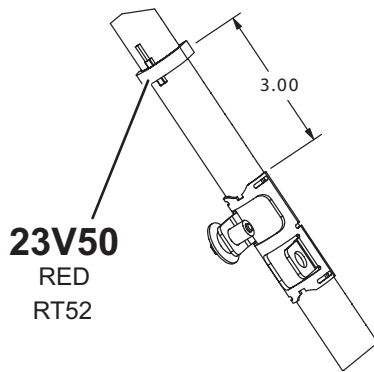

FIGURE 33

LGT/LCT180
CONDENSER / OUTDOOR COIL
RT48, 49, 52



DETAIL C



DETAIL D

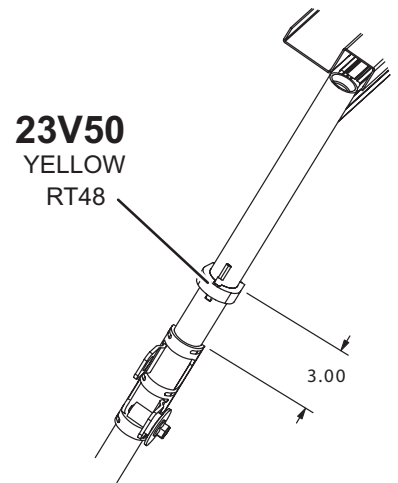

DETAIL E

DETAILS NOT TO SCALE

FIGURE 34

LGT/LCT210, 240, 300
EVAPORATOR / INDOOR COIL
RT46, 47, 50, 51

SEE DETAIL C

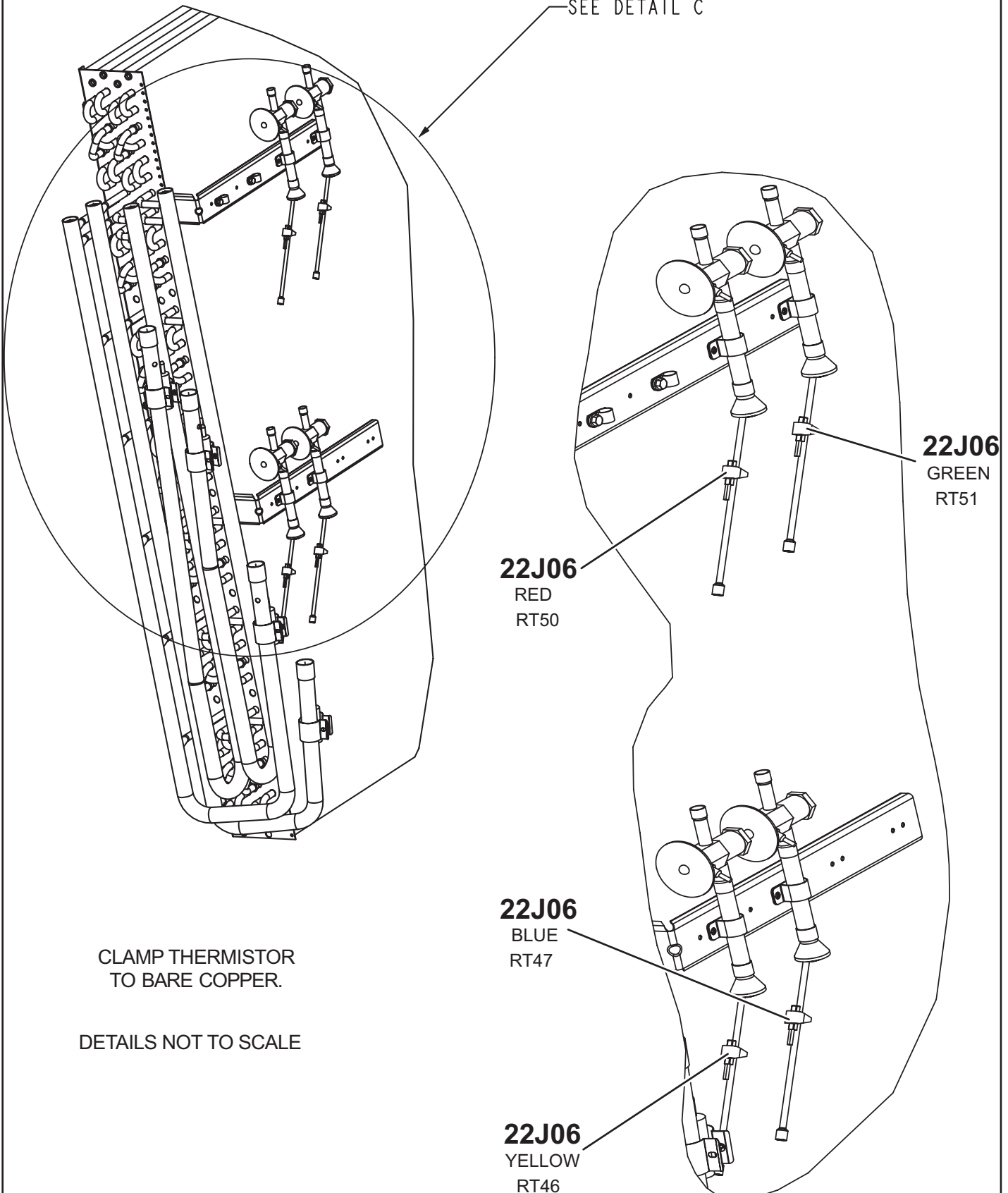

CLAMP THERMISTOR
TO BARE COPPER.

DETAILS NOT TO SCALE

22J06
RED
RT50

22J06
GREEN
RT51

22J06
BLUE
RT47

22J06
YELLOW
RT46

FIGURE 35

LGT/LCT/LHT/LDT210, 240, 300
 CONDENSER / OUTDOOR COIL
 RT48, 49, 52, 53

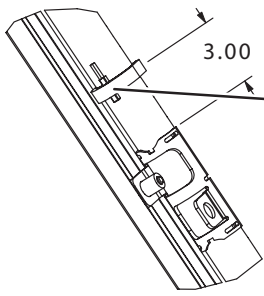
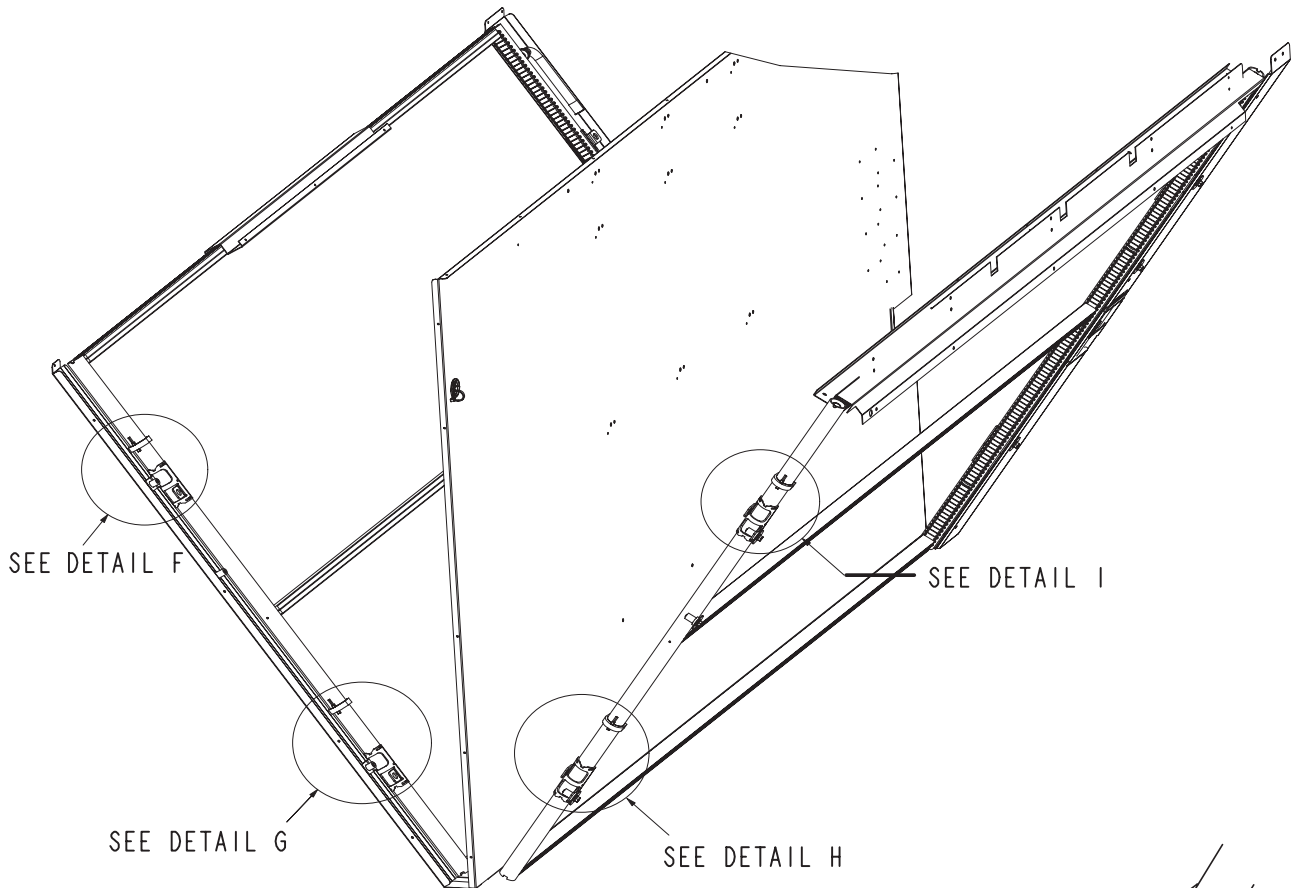

23V50
 BLUE
 RT49

SEE DETAIL F

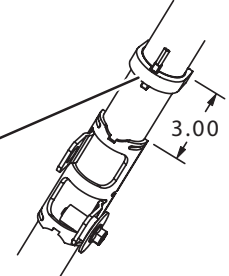

23V50
 GREEN
 RT53

SEE DETAIL I

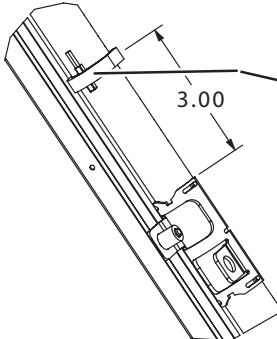

23V50
 YELLOW
 RT48

SEE DETAIL G

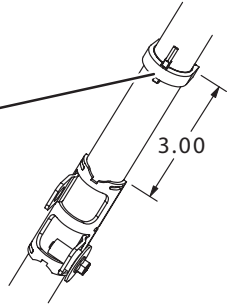

23V50
 RED
 RT52

SEE DETAIL H

DETAILS NOT TO SCALE

FIGURE 36

RDS Sensors

Units are equipped with factory-installed RDS Sensors located on different points on the unit. The RDS sensors provide the Unit Controller with continuous readings for leaked refrigerant concentration levels and sensor health status (Good or Fault). These readings are used to modify unit operation to disperse the leaked refrigerant and to remove possible ignition sources. In addition, the Unit Controller uses these readings to initiate alarms to alert the operator of a refrigerant leak or faulty sensor(s).

Each sensor must be specifically placed for proper unit operation and to initiate valid alarms. To identify sensor locations see TABLE 18.

TABLE 18

Unit Model	Figure
Indoor Coil Area Sensor	FIGURE 37
Control/Compressor Compartment Sensor	FIGURE 38

LGT/LCT 156-300 INDOOR COMPARTMENT RDS SENSOR

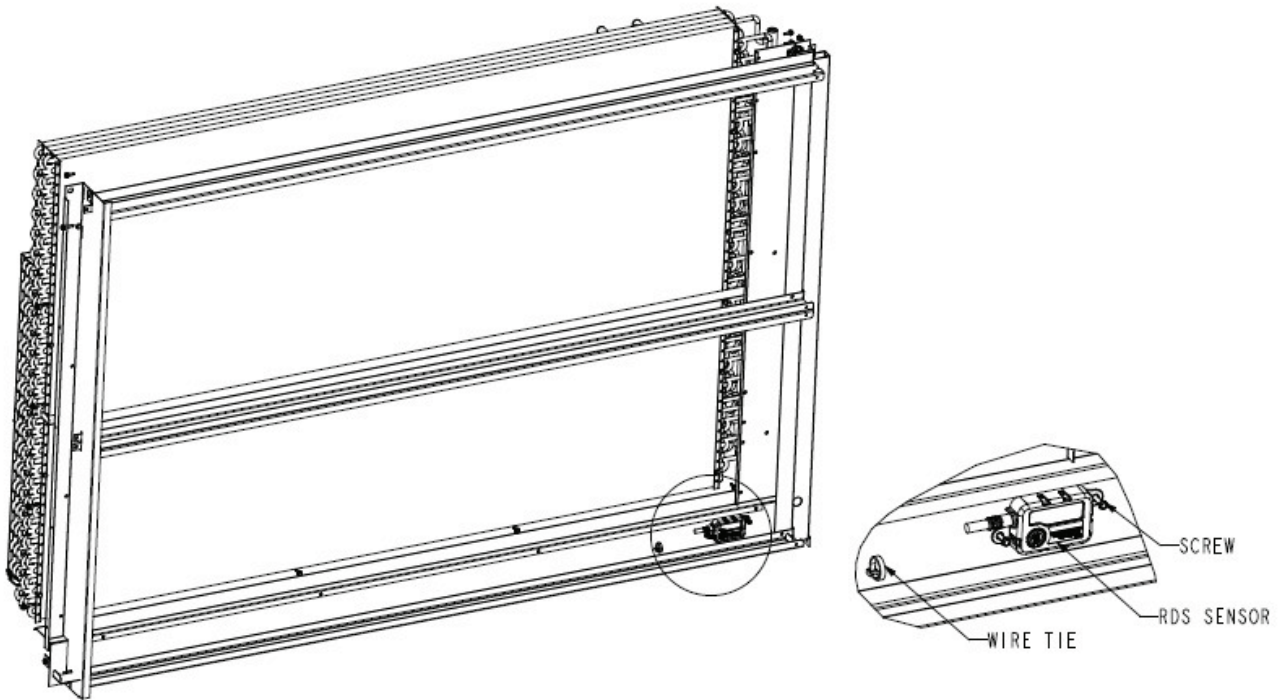

FIGURE 37

LGT/LCT 156-300
COMPRESSOR RDS SENSOR

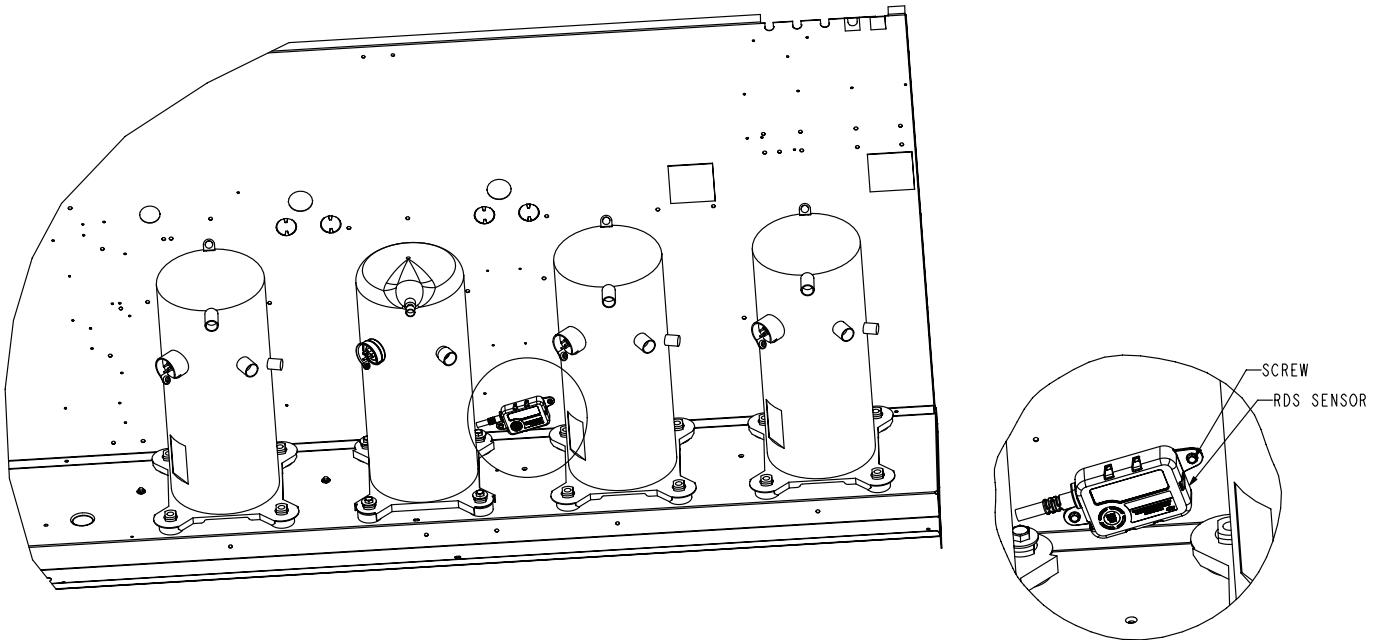

FIGURE 38

Gas Heat Start-Up (Gas Units)

FOR YOUR SAFETY READ BEFORE LIGHTING

BEFORE LIGHTING smell all around the appliance area for gas. Be sure to smell next to the floor because some gas is heavier than air and will settle on the floor.

Use only your hand to push in or turn the gas control knob. Never use tools. If the knob will not push in or turn by hand, do not try to repair it, call a qualified service technician. Force or attempted repair may result in a fire or explosion.

This unit is equipped with an automatic spark ignition system.

There is no pilot. In case of a safety shutdown, move thermostat switch to **OFF** and return the thermostat switch to **HEAT** to reset ignition control.

⚠ WARNING



Electric shock hazard. Can cause injury or death. Do not use this unit if any part has been under water. Immediately call a qualified service technician to inspect the unit and to replace any part of the control system and any gas control which has been under water.

⚠ WARNING



Danger of explosion. Can cause injury or product or property damage. If overheating occurs or if gas supply fails to shut off, shut off the manual gas valve to the appliance before shutting off electrical supply.

⚠ WARNING



Electric shock hazard. Can cause injury or death. Before attempting to perform any service or maintenance, turn the electrical power to unit OFF at disconnect switch(es). Unit may have multiple power supplies.

⚠ WARNING

SMOKE POTENTIAL

The heat exchanger in this unit could be a source of smoke on initial firing. Take precautions with respect to building occupants and property. Vent initial supply air outside when possible.

⚠ WARNING



Danger of explosion. Can cause injury or death. Do not attempt to light manually. Unit has a direct spark ignition system.

⚠ WARNING



Danger of explosion and fire. Can cause injury or product or property damage. You must follow these instructions exactly.

A-Placing Unit in Operation

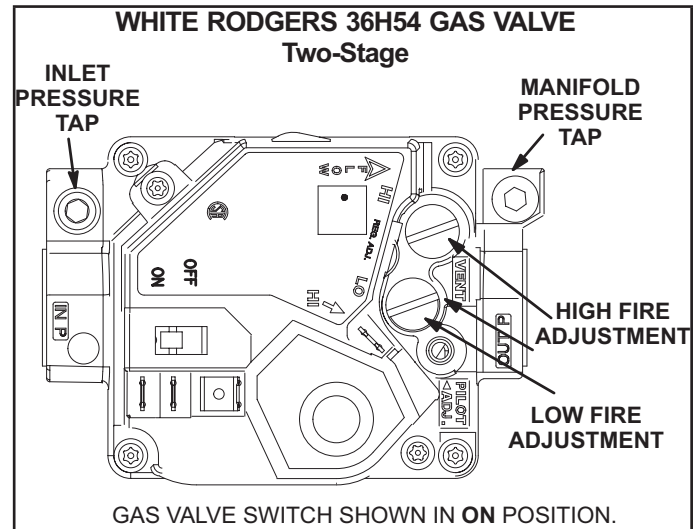

FIGURE 39

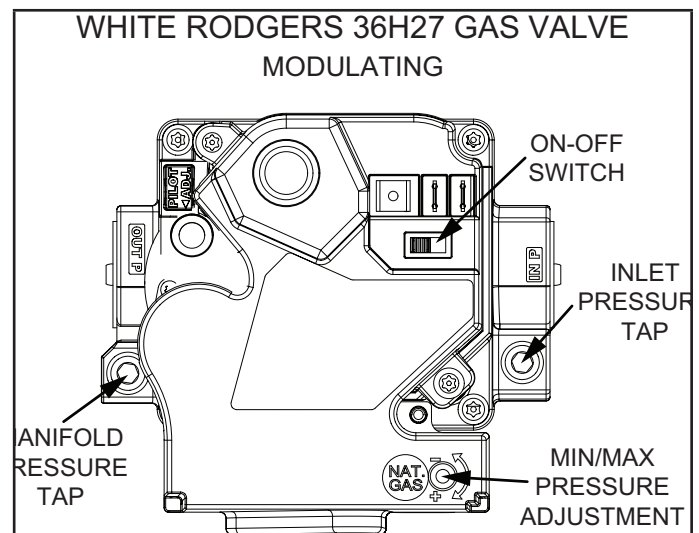

FIGURE 40

- 1 - Set thermostat to lowest setting.
- 2 - Turn off all electrical power to appliance.
- 3 - This appliance is equipped with an ignition device which automatically lights the burner. Do **not** try to light the burner by hand.
- 4 - Open or remove the heat section access panel.
- 5 - Turn gas valve switch to **OFF**. See FIGURE 39 and FIGURE 40.

- 6 - Wait five (5) minutes to clear out any gas. If you then smell gas, **STOP!** Immediately call your gas supplier from a neighbor's phone. Follow the gas supplier's instructions. If you do not smell gas, go to the next step.
- 7 - Turn gas valve switch to **ON**. See FIGURE 39 and FIGURE 40.
- 8 - Close or replace the heat section access panel.
- 9 - Turn on all electrical power to appliance.

NOTE - When unit is initially started, steps 1 through 9 may need to be repeated to purge air from gas line.

- 10 -Set thermostat to desired setting.
- 11 -The ignition sequence will start.
- 12 -If the appliance does not light the first time (gas line not fully purged), it will attempt up to two more ignitions before locking out.
- 13 -If lockout occurs, repeat steps 1 through 10.
- 14 -If the appliance will not operate, follow the instructions "Turning Off Gas to Appliance" and call your service technician or gas supplier.

Turning Off Gas to Unit

- 1 - If using an electromechanical thermostat, set to the lowest setting.
- 2 - Before performing any service, turn off all electrical power to the appliance.
- 3 - Open or remove the heat section access panel.
- 4 - Turn gas valve switch to **OFF**.
- 5 - Close or replace the heat section access panel.

⚠ WARNING	
	Danger of explosion. Can cause injury or death. Do not attempt to light manually. Unit has a direct spark ignition system.

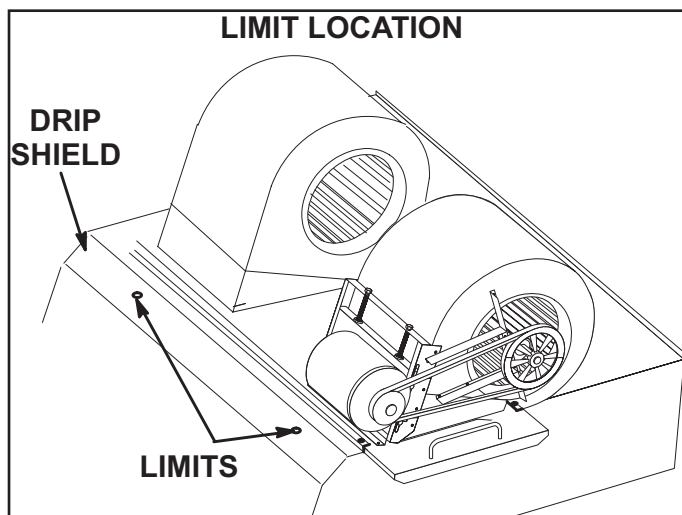

FIGURE 41

Gas Heating Operation

A-Heating Sequence of Operation

Two-Stage and Modulating

- 1 - On a heating demand the CORE transmits a demand signal (W1, W2) to the Direct Spark Ignition (DSI) control. For Modulating systems, CORE transmits an additional signal, Gas Valve Position, to the DSI control.
- 2 - DSI control immediately activates the combustion air inducer.
- 3 - Combustion air pressure switch proves inducer operation before allowing ignition sequence to start.
- 4 - After a 30 second pre-purge time, DSI control energizes the spark ignitor and opens the gas valve to Low Fire (Two-Stage) or minimum position (Modulating)
- 5 - The spark then ignites the gas and flame is verified by flame sensor.

NOTE - If flame is not detected, the DSI control will close the gas valve and repeat steps 4 and 5 two more times.

- 6 - After the warmup period ends, CORE control starts the blower operation.

Heating Demand – Two-Stage

- 1 - CORE operates indoor blower at the Blower Heating High CFM Setpoint (refer to TABLE 22).
- 2 - When thermostat initiates W2 demand, CORE transmits W2 signal to DSI control.
- 3 - DSI control opens the gas valve to High Fire and changes CAI speed from low to high.

Heating Demand – Modulating

- 1 - CORE operates indoor blower at Blower Heating Low CFM setpoint (refer to TABLE 22).
- 2 - MGV Position is consistently updated by the CORE during heating demand.
 - a. CORE monitors the Discharge Air Temperature (DAT) sensor and compares its value to the setpoint.
 - b. CORE calculates a new MGV Position.
 - c. CORE transmits new MGV Position to MGV which responds accordingly.
 - d. Steps a) thru c) are repeated until heating demand has been satisfied.
- 3 - Increasing MGV Position (minimum, moving toward maximum).
 - a. When CORE increases the MGV Position above programmed value, CORE outputs W2 signal to the DSI control.
 - b. DSI control changes CAI speed from low to high.

- c. CORE changes indoor blower operation to Blower Heating High CFM setpoint (refer to TABLE 22).
- 4 - Decreasing MGV Position (maximum, moving toward minimum).
- a. When CORE decreases MGV Position to minimum and CORE holds MGV in minimum position for preset time period, CORE removes W2 signal to DSI control.
 - b. DSI control changes CAI speed from high to low.
 - c. CORE changes indoor blower operation to Blower Heating Low CFM setpoint (refer to TABLE 22).

Termination – Two-Stage and Modulating

- 1 - When thermostat demand is satisfied, heating demands (W1, W2) are removed from CORE.
- 2 - CORE removes any active demand signals (W1, W2) to DSI control. For Modulating systems, the CORE removes the MGV Position signal too.
- 3 - DSI control closes the gas valve.
- 4 - DSI control maintains CAI operation for post purge period (45 seconds), then shuts off CAI.
- 5 - CORE maintains indoor blower operation until Gas Blower Off Delay expires, then CORE shuts off the indoor blower.

B-Ignition Control Diagnostic LEDs

The table below refers to several components. The components and wiring diagram key numbers are: DSI Control Board (A3); Gas Valve (GV1 or GV4); Primary Limit Switch (S10); Combustion Air Blower Proofing Switch (S18); Rollout Switch (S47). Refer to the unit wiring diagram for further details.

TABLE 19

IGNITION CONTROL HEARTBEAT LED STATUS

LED Flashes	Indicates
Slow Flash	Normal Operation – No call for heat
Fast Flash	Normal Operation - call for heat
Steady Off	Internal control board fault or no power
Steady On	Control board failure
1 Flash	Rollout Switch open
2 Flashes	Limit Switch open or opened multiple times during one heating demand
3 Flashes	Pressure Switch open with CAI ON
4 Flashes	Control lockout – failed to detect or sustain flame
5 Flashes	Flame sensed and gas valve not energize
6 Flashes	Pressure Switch closed with CAI OFF
7 Flashes	Not used
8 Flashes	Pressure switch opened repeatedly during heating demand

Gas Heating Checks and Adjustments

A-Gas Flow

To check for proper gas flow, determine the Btu input from the unit rating plate. Divide this input rating by the Btu per cubic feet of available gas. Result is the required number of cubic feet per hour. Determine the flow of gas through the gas meter for two minutes and multiply by 30 to get the hourly flow of gas.

B-Supply Gas Pressure

Supply pressure should be checked with unit firing at maximum rate. For Natural Gas, supply pressure should be maintained in accordance with the specified minimum and maximum supply pressures on the unit rating plate.

For LP/propane, a natural gas to LP/propane gas changeover kit is required to convert the unit in the field. Refer to installation instructions provided with changeover kit for conversion procedure along with propane minimum and maximum supply pressures.

NOTE - On multiple unit installations, each unit should be checked separately, with and without other units operating. Supply pressures on both single and multiple unit installations must fall within range listed on the rating plate.

C-Supply Gas Pressure Measurement

- 1 - Shut off the manual main supply valve (field furnished) when installing or removing the measuring device (Steps 2 and 6).
- 2 - Connect the measuring device based upon type of gas valve.

For White Rodgers 36H54 and 36H27 valves (FIGURE 39 and FIGURE 40), supply pressure is accessed by removing 1/8" hex screw. Remove the 1/8" hex screw and install a 1/8" fitting with hose barb. Connect tubing from the barbed fitting and route to measuring device to measure supply pressure.
- 3 - Open manual main supply valve.
- 4 - Ignite unit and let run for 5 minutes to allow for steady state conditions.
- 5 - After allowing unit to stabilize for 5 minutes, record supply pressure.
- 6 - Shut unit off and remove measuring device, tubing, or fittings as soon as an accurate reading has been obtained.

For White Rodgers 36H54 and 36H27 valves (FIGURE 39 and FIGURE 40), remove supply pressure barbed fitting and reinstall the 1/8" hex screw.

D-Manifold Pressure Measurement and Adjustment

- 1 - Connect the measuring device based upon the type of gas valve.
For White Rodgers 36H54 and 36H27 valves (FIGURE 39 and FIGURE 40) manifold pressure, remove the 1/8" hex screw, install 1/8" fitting with hose barb, connect hose from barb to "+" side of measuring device.
- 2 - Ignite unit and let run for 5 minutes to allow for steady state conditions. If unit has 2 heating inputs, start on higher input.
- 3 - After allowing unit to stabilize for 5 minutes, record manifold pressure. Compare measurement to the unit nameplate values.

NOTE - For elevations higher than 4500 feet above sea level, see *High Altitude Adjustment* section for details.

- 4 - If necessary, adjust manifold pressure. FIGURE 39 and FIGURE 40 show adjustment screw(s) locations.
- 5 - Repeat steps 3, 4 and 5 on lower input.
- 6 - Shut unit off and remove measuring device as soon as accurate reading has been obtained.
For White Rodgers 36H54 and 36H27 valves (FIGURE 39 and FIGURE 40), remove 1/8" fitting with hose barb and reinstall 1/8" hex screw.
- 7 - Start unit and perform leak check. Seal leaks if found.

E-High Altitude Adjustments

Locate the high altitude conversion sticker in the unit literature bag. Fill out the conversion sticker and affix next to the unit nameplate. High altitude kits are available for field-installation.

Refer to TABLE 20 for high altitude adjustments.

TABLE 20

Altitude in Feet (Meters)*	Gas Manifold Pressure
2001 – 4500 (610 – 1372)	See unit nameplate
4500 (1372) and Above	Derate 4% per 1000 ft. (305 m) above sea level

*Units installed at 0-2000 feet do not need to be modified

NOTE - This is the only permissible derate for these units.

Electric Heat Start-Up (LCT Units)

Factory or Field-Installed Option

Electric heat will stage on and cycle with thermostat demand. Number of stages of electric heat will vary depending on electric heat assembly. See electric heat wiring diagram on unit for sequence of operation.

Multi-Stage Air Volume Start-Up

A-Design Specifications

Use TABLE 21 to fill in field-provided, design specified blower CFM for appropriate unit.

If only high and low cooling design specifications are provided, set the medium cooling CFM at the high or low cooling design spec or any CFM between.

B-Set Maximum CFM

Use TABLE 22 to determine highest blower CFM for appropriate unit. Adjust the blower pulley to deliver that amount of CFM with only the blower operating. See Determining Unit CFM in the Blower Operation and Adjustment section.

C-Set Blower Speeds

- 1 - Use the following mobile service app menu to enter the blower design specified CFM into the Unit Controller. Make sure blower CFM is within limitations shown in TABLE 22 or TABLE 23. Refer to the Unit Controller manual provided with unit.

RTU MENU > RTU OPTIONS > BLOWER > SPEED

- 2 - Enter the following design specifications as shown in TABLE 21.

Blower / Heat CFM
Cooling High CFM
Cooling Low CFM
Vent CFM

- 3 - Adjust the blower RPM to deliver the target CFM based on the measured static pressure using the blower table.
- 4 - Measure the static pressure again and apply the static pressure and RPM to the blower tables to determine adjusted CFM.
- 5 - Repeat adjustments until design CFM is reached.

D-Set Damper Minimum Position

To maintain required minimum ventilation air volumes when the unit is in the occupied mode, two minimum damper positions must be set.

The Unit Controller will open the damper to "Min OCP Blwr High" when blower CFM is at or ABOVE the "midpoint" CFM.

The Unit Controller will open the dampers to "Min OCP Blwr Low" when blower CFM is BELOW a "midpoint" CFM.

The Unit Controller will calculate the "midpoint" CFM.

TABLE 21
Blower CFM Design Specifications

Unit	T'Stat or Zone Control Stages	Blower Speed	Design Specified CFM
156	2	Htg.	
		Clg. High	
		Clg. Low	
		Ventilation	
180	2	Htg.	
		Clg. High	
		Clg. Low	
		Ventilation	
210	2	Htg.	
		Clg. High	
		Clg. Low	
		Ventilation	
240	2	Htg.	
		Clg. High	
		Clg. Low	
		Ventilation	
300	2	Htg.	
		Clg. High	
		Clg. Low	
		Ventilation	

*Available blower speed vary by unit and thermostat stages.

Set Minimum Position 1

Use the following mobile service app menu to set “Min OCP Blwr High” for the blower CFM above the “midpoint” CFM. When navigating into this menu, the Unit Controller will run damper calibration and allow damper position adjustment.

RTU MENU > SETTINGS > RTU OPTIONS > DAMPER

Tap “Next” to skip tabs and complete damper position calibration until “Damper Calibration Blower Speed High” tab appears.

Measure the intake air CFM. If the CFM is lower than the design specified CFM for ventilation air, use the Unit Controller to increase the damper percent open. If the CFM is higher than specified, decrease the damper percent open.

NOTE - Intake air CFM can also be determined using the outdoor air temperature, return air temperature and mixed air temperature. Refer to the economizer or outdoor air damper installation instructions.

**TABLE 22
HEATING, VENTILATION, & SMOKE MINIMUM AND MAXIMUM CFM**

Tons	Unit			Heating CFM			Vent CFM			Smoke CFM		
	Model	Speed	Heat Code	Default	Min.	Max.	Default	Min.	Max.	Default	Min.	Max.
13	LGT156H	Low	L	5200	2725	6250	5200	1950		5200	1950	6250
		Std	S		4325							
		Med	M		4500							
	LCT156H	All	N, E, J, K, L		5200							
15	LGT180H	Low	L	6000	2725	7200	6000	2250		6000	2250	7200
		Std	S		4325							
		Med	M		4500							
		High	H		5125							
	LCT180H	15, 30, 45, 60kW	N, E, J, K, L		5200							
17.5	LGT210H	Low, Std, Med	L, S, M	7000	4500	8400	7000	2625		7000	2625	8400
		High	H		5125							
	LCT210H	15, 30, 45, 60kW	N, E, J, K, L		5200							
		90kW	P		6000							
20	LGT240H	Low, Std, Med	L, S, M	8000	4500	9600	8000	3000		8000	3000	9600
		High	H		5125							
	LCT240H	15, 30, 45, 60kW	N, E, J, K, L		5200							
		90kW	P		6000							
25	LGT300H	Low, Std, Med	L, S, M	10000	4500	10000	3750			10000	3750	12000
		High	H		5125							
	LCT300H	15, 30, 45, 60kW	N, E, J, K, L		5200							
		90kW	P									

*Use highest value between Heating and Cooling High CFM Max.

**TABLE 23
COOLING MINIMUM AND MAXIMUM CFM**

LGT/ LCT Unit	Cool 1 CFM Cooling Low CFM			Cool 4 CFM Cooling High CFM		
	Default	Min.	Max.	Default	Min.	Max.
156H	3380	1500	6250	5200	4000	6250
180H	3900	2000	7200	5400	5000	7200
210H	4550	2500	8400	6300	6000	8400
240H	5200	3000	9600	7200	6250	9600
300H	6500	3500	12000	9000	7000	12000

*Use Cooling High CFM Max

Set Minimum Position 2

Use the following mobile service app menu in the Unit Controller to set “Min OCP Blwr Low” for the blower CFM below the “midpoint” CFM. When navigating into this menu, the Unit Controller will run damper calibration and allow damper position adjustment.

RTU MENU > SETTINGS > RTU OPTIONS > DAMPER

Tap “Next” to skip tabs and complete damper position calibration until “Damper Calibration Blower Speed High” tab appears.

Measure the intake air CFM. If the CFM is lower than the design specified CFM for ventilation air, use the Unit Controller to increase the damper percent open. If the CFM is higher than specified, decrease the damper percent open.

NOTE - Intake air CFM can also be determined using the outdoor air temperature, return air temperature and mixed air temperature. Refer to the economizer or outdoor air damper installation instructions.

E-Inverter Bypass Option

The supply air inverter is factory-set to by-pass the inverter manually. To by-pass the inverter and operate the blower in the constant air volume mode, use the following Unit Controller menu and set to “engaged”:

SETTINGS > RTU OPTIONS > BLOWER > VFD BYPASS

To configure the unit to by-pass the inverter automatically, use the following Unit Controller menu.

SETUP > INSTALL

Press SAVE until the menu reads:

CONFIGURATION ID 1

Change the 6th character position to A for automatic bypass option.

Press SAVE

CAUTION - Units not equipped with an inverter will have the 6th character set to N, indicating the inverter is not bypassed. The blower motor could be damaged and/or result in product or property damage if the setting is changed to automatic or manual.

Objective: Outline the unit functions as a result of room thermostat or zone sensor demands.

Given: When economizer is present, it will function as an integral part of the unit cooling system. When not present, unit will function as if economizer is present but outdoor ambient is high and sensed as not suitable.

156 MODELS (2 COMPRESSORS)

UNIT OPERATION WITH 2-STAGE THERMOSTAT (2 COOL AND 2 HEAT STAGES, STAGE 1, STAGE 2, W1, W2)

SUPPLY AIR BLOWER SPEED

Unit has following supply air blower speed setting:

- Ventilation speed
- Cooling Speed - Low
- Cooling Speed - High
- Heating Speed
- Smoke Speed (Using only in smoke removal option - not discussed)

¹ Unit Features and Economizer and Outdoor Air is Suitable

Cooling - Thermostat or Zone Sensor Mode (STAGE 1, STAGE 2, STAGE 3)

Stage 1 Cooling Demand:

All compressors are off, supply air blower is on low cooling speed to minimize blower power consumption, economizer modulates (minimum to maximum open position) to maintain 55°F supply air temperature (default unit controller setting).

Stage 2 Cooling Demand:

All compressors are off, supply air blower is on high cooling speed providing higher cooling capacity, and economizer modulates to maintain 55°F supply air temperature. If economizer stays at maximum open for 3 minutes, compressor 1 is energized at full cooling capacity while supply air blower stays on high cooling speed providing maximum cooling capacity.

¹ Outdoor air suitability is determined by the energy state of outdoor ambient (enthalpy or sensible) and its ability to achieve the desired free cooling effects. Outdoor air suitability can also be determined by a third party controller and provided to the rooftop unit via a network connection.

Unit Does Not Feature An Economizer Or Outdoor Air Is Not Suitable

Stage 1 Cooling Demand:

Compressor 1 operates at full cooling capacity and supply air blower operates at low cooling speed.

Stage 2 Cooling Demand:

All compressors operate at max cooling capacity and supply air blower operates at high cooling speed.

Dehumidification Mode

If a reheat unit receives a call for dehumidification, economizer free cooling is locked out.

Call For Dehumidification, No Stage 1, Stage 2 Cooling Demand:

1st and 2nd stage compressor operate at max cooling capacity, supply air blower operates at low cooling speed, and the reheat valves 1,2 are energized.

Stage 1 Cooling Demand With A Call For Dehumidification:

All compressors operate at max cooling capacity, supply air blower operates at high cooling speed, reheat valve 1 is energized, reheat valve 2 is deenergized.

Stage 2 Cooling Demand With A Call For Dehumidification:

All compressors operate at max cooling capacity, supply air blower operates at high cooling speed, and the reheat valves 1,2 are deenergized.

156 MODELS (2 COMPRESSORS)**UNIT OPERATION WITH 3-STAGE THERMOSTAT OR ZONE SENSOR (3 COOL AND 2 HEAT STAGES, STAGE 1, STAGE 2, STAGE 3 AND W1, W2)**

Unit has following supply air blower speed setting:

- Ventilation speed
- Cooling Speed – Low
- Cooling Speed – Medium
- Cooling Speed – High
- Heating speed
- Smoke speed (Used only in smoke removal option - not discussed)

¹ Unit Features and Economizer and Outdoor Air is Suitable

Stage 1 Cooling Demand:

All compressors are off, supply air blower is on medium cooling speed to minimize blower power consumption, economizer modulates (minimum to maximum open position) to maintain 55°F supply air temperature (default unit controller setting).

Stage 2 Cooling Demand:

All compressors are off, supply air blower is on high cooling speed providing higher cooling capacity, and economizer modulates to maintain 55°F supply air temperature. If economizer stays at maximum open for 3 minutes, compressor 1 is energized at part load capacity while supply air blower stays on high cooling speed providing maximum cooling capacity. After compressors are energized the economizer stays at maximum open.

Stage 3 Cooling Demand:

Compressor 1 is energized at full capacity while supply air blower stays on high cooling speed, economizer stays at maximum open.

¹ Outdoor air suitability is determined by the energy state of outdoor ambient (enthalpy or sensible) and its ability to achieve the desired free cooling effects. Outdoor air suitability can also be determined by a third party controller and provided to the rooftop unit via a network connection.

Unit Does Not Feature An Economizer Or Outdoor Air Is Not Suitable**Stage 1 Cooling Demand:**

Compressor 1 operates at full cooling capacity and supply air blower operates at low cooling speed.

Stage 2 Cooling Demand:

Compressor 1 operates at part load with compressor 2 ON, and supply air blower operates at medium cooling speed.

Stage 3 Cooling Demand:

All compressors operate at max cooling capacity and supply air blower operates at high cooling speed.

Dehumidification Mode

If a reheat unit receives a call for dehumidification, economizer free cooling is locked out.

Call For Dehumidification, No Stage 1, Stage 2 Cooling Demand:

Compressor 1,2 operates at full cooling capacity, supply air blower operates at low cooling speed, and the reheat valves 1,2 are energized.

Stage 1 Cooling Demand With A Call For Dehumidification:

Compressor 1,2 operates at full cooling capacity, supply air blower operates at low cooling speed and the reheat valve 1 is energized, reheat valve 2 is deenergized.

Stage 2 Cooling Demand With A Call For Dehumidification:

Compressor 1,2 operates at full cooling capacity, supply air blower operates at high cooling speed and the reheat valve 1 is energized, reheat valve 2 is deenergized.

Stage 3 Cooling Demand With A Call For Dehumidification:

Compressor 1,2 operates at full cooling capacity, supply air blower operates at high cooling speed, and the reheat valves 1,2 are deenergized.

180/210/240/300 MODELS (3 AND 4 COMPRESSORS)**UNIT OPERATION WITH 2-STAGE THERMOSTAT (2 COOLING STAGES, STAGE 1, STAGE 2)****SUPPLY AIR BLOWER SPEED**

Unit has following supply air blower speed setting:

- Ventilation speed
- Cooling Sped - Low
- Cooling Speed - High
- Heating Speed
- Smoke Speed (Using only in smoke removal option - not discussed)

¹ Unit Features and Economizer and Outdoor Air is Suitable

Stage 1 Cooling Demand:

All compressors are off, supply air blower is on low cooling speed to minimize blower power consumption, economizer modulates (minimum to maximum open position) to maintain 55°F supply air temperature (default unit controller setting).

Stage 2 Cooling Demand:

All compressors are off, supply air blower is on high cooling speed providing higher cooling capacity, and economizer modulates to maintain 55°F supply air temperature. If economizer stays at maximum open for 3 minutes, 1st stage compressors (compressor 1 and 2) are energized while supply air blower stays on high cooling speed providing maximum cooling capacity.

¹ Outdoor air suitability is determined by the energy state of outdoor ambient (enthalpy or sensible) and its ability to achieve the desired free cooling effects. Outdoor air suitability can also be determined by a third party controller and provided to the rooftop unit via a network connection.

Unit Does Not Feature An Economizer Or Outdoor Air Is Not Suitable**Stage 1 Cooling Demand:**

1st stage compressors operate and supply air blower operates at low cooling speed.

Stage 2 Cooling Demand:

All compressors operate and supply air blower operates at high cooling speed.

Dehumidification Mode

If a reheat unit receives a call for dehumidification, economizer free cooling is locked out.

Call For Dehumidification, No Stage 1, Stage 2 Cooling Demand:

1st stage compressors (1 & 2) operate, supply air blower operates at high cooling speed, and the reheat valves are energized.

Stage 1 Cooling Demand With A Call For Dehumidification:

All compressors operate, supply air blower operates at high cooling speed and the reheat valves are energized.

Stage 2 Cooling Demand With A Call For Dehumidification:

All compressors operate, supply air blower operates at high cooling speed, and the reheat valves are de-energized.

180/210/240/300 MODELS (3 AND 4 COMPRESSORS)**UNIT WITH 3-STAGE THERMOSTAT (3 COOLING STAGES, STAGE 1, STAGE 2, STAGE 3) OR 3 COMPRESSORS MODELS - ZONE SENSOR (4 COOLING STAGES, STAGE 1, STAGE 2, STAGE 3, STAGE 4)****SUPPLY AIR BLOWER SPEED**

Unit has following supply air blower speed setting:

- Ventilation speed
- Cooling Speed - Low
- Cooling Speed - Medium
- Cooling Speed - High
- Heating Speed
- Smoke Speed (Using only in smoke removal option - not discussed)

¹ Unit Features and Economizer and Outdoor Air is Suitable

3 Compressor Units**Stage 1 Cooling Demand:**

All compressors are off, supply air blower is on low cooling speed to minimize blower power consumption, economizer modulates (minimum to maximum open position) to maintain 55°F supply air temperature (default unit controller setting).

Stage 2 Cooling Demand:

All compressors are off, supply air blower is on high cooling speed providing higher cooling capacity, economizer modulates (minimum to maximum open position) to maintain 55°F supply air temperature (default unit controller setting).

If economizer stays at maximum open for 3 minutes then compressor 1 is energized while supply air blower stays on high cooling speed. After compressor is energized the economizer stays at maximum open.

Stage 3 Cooling Demand:

Compressors 1 and 2 are energized while supply air blower stays on high cooling speed. After compressors are energized the economizer stays at maximum.

Stage 4 Cooling (Zone Sensor Only) Demand:

All compressors are energized and supply air blower stays on high cooling speed.

4 Compressor Units**Stage 1 Cooling Demand:**

All compressors are off, supply air blower is on low cooling speed to minimize blower power consumption, economizer modulates (minimum to maximum open position) to maintain 55°F supply air temperature (default unit controller setting).

Stage 2 Cooling Demand:

All compressors are off, supply air blower is on high cooling speed providing higher cooling capacity, economizer modulates (minimum to maximum open position) to maintain 55°F supply air temperature (default unit controller setting).

If economizer stays at maximum open for 3 minutes then compressors 1 and 2 are energized while supply air blower stays on high cooling speed. After compressors are energized the economizer stays at maximum open.

Stage 3 Cooling Demand:

Compressors 1, 2 and 3 are energized and supply air blower stays on high cooling speed.

¹ Outdoor air suitability is determined by the energy state of outdoor ambient (enthalpy or sensible) and its ability to achieve the desired free cooling effects. Outdoor air suitability can also be determined by a third party controller and provided to the rooftop unit via a network connection.

180/210/240/300 MODELS (3 AND 4 COMPRESSORS) (CONTINUED)**UNIT WITH 3-STAGE THERMOSTAT (3 COOLING STAGES, STAGE 1, STAGE 2, STAGE 3) OR 3 COMPRESSORS MODELS - ZONE SENSOR (4 COOLING STAGES, STAGE 1, STAGE 2, STAGE 3, STAGE 4)**

Unit Does Not Feature An Economizer Or Outdoor Air Is Not Suitable

3 Compressor Units**Stage 1 Cooling Demand:**

Compressor 1 operates and supply air blower operates at low cooling speed.

Stage 2 Cooling Demand:

Compressors 1 and 2 operate and supply air blower operates at medium cooling speed.

Stage 3 or Stage 4 Cooling (Zone Sensor Only) Demand:

All compressors operate and supply air blower operates at high cooling speed .

4 Compressor Units**Stage 1 Cooling Demand:**

Compressors 1 and 2 operate and supply air blower operates at low cooling speed.

Stage 2 Cooling Demand:

Compressors 1, 2, and 3 operate and supply air blower operates at medium cooling speed.

Stage 3 Cooling Demand:

All compressors operate and supply air blower operates at high cooling speed.

Dehumidification Mode

If a reheat unit receives a call for dehumidification, economizer free cooling is locked out.

Call For Dehumidification, No Stage 1, Stage 2 Cooling Demand:

Compressor 1 and 2 operate, supply air blower operates at high cooling speed, and both reheat valves are energized.

Stage 1 Cooling Demand With A Call For Dehumidification:

All compressors operate, supply air blower operates at high cooling speed and both reheat valves are energized.

Stage 2 Cooling Demand With A Call For Dehumidification:

All compressors operate, supply air blower operates at high cooling speed, and the reheat valve of refrigeration circuit 1 is energized while the reheat valve of refrigeration circuit 2 is de-energized.

Stage 3 or Stage 4 Cooling (Zone Sensor Only) Demand:

All compressors operate, supply air blower operates at high cooling speed, and both reheat valves are de-energized.

Modulating Gas Heating Mode: Thermostat (Up to 2 stages W1, W2)**W1 or Low Heating Demand**

Supply fan operates at low heating speed and Gas valves stage up/down and modulate to maintain Discharge Air Temperature (DAT) set-point.

W2 or High Heating Demand

Supply fan operates at high heating speed and Gas valves stage up/down and modulates to maintain Discharge Air Temperature (DAT) set-point.

Modulating Gas Heating Mode: Zone Sensor

Heating demand is based on delta and duration of Zone Air Temperature (ZAT) away from ZAT set-point. Based on heating demand, supply fan modulates between low heating speed and high heating speed while Gas valves stage up/down and modulate to maintain Discharge Air Temperature (DAT) set-point as the blower speed changes.

UNITS IN ZONING APPLICATIONS OPERATING WITH DISCHARGE AIR CONTROL

The blower fully modulates based on supply duct static pressure, during cooling, heating, ventilation, and smoke operation.

COOLING**Cooling Mode**

- Discharge air temperature (DAT) can be used to control unit staging.
- DAT default setpoint = 55°F. Unit will stage compressors as required to maintain the setpoint when cooling demand is provided. A Y1 setpoint can provide cooling demand.
- Increasing compressor stages provides more cooling capacity while decreasing compressor stages provides less cooling capacity.
- **In Thermostat mode**, the unit can operate up to four stages, enabled by Y1 input. The supply fan operates to maintain Duct Static setpoint and the unit operates compressors to maintain Discharge Air Temperature (DAT) setpoint as the blower speed changes.
- **In Zone Sensor mode**, the zone air temp setpoint signal is sent to initiate cooling operation. The supply fan operates to maintain Duct Static setpoint and the unit operates compressors to maintain Discharge Air Temperature (DAT) setpoint as the blower speed changes. When the zone air temp has reached the setpoint, the cooling operation is deactivated.

Unit Features An Economizer And Outdoor Air Is Suitable

- Supply air blower operates to maintain duct static pressure
- Compressors are energized and the economizer modulates (minimum to maximum open position) to maintain 55°F supply air temperature (default unit controller setting)

Outdoor air suitability is determined by the energy state of outdoor ambient (enthalpy or sensible) and its ability to achieve the desired free cooling effects. Outdoor air suitability can also be determined by a third party controller and provided to the RTU via a network connection

HEATING**Staged Heating Mode**

- Discharge air temperature (DAT) can be used to control unit staging.
- DAT default setpoint = 110°F. Unit will stage heating as required to maintain the setpoint when provided with W1 demand.
- Increasing heat stages provides more heating capacity while decreasing heat stages provides less heating capacity.
- Blower operates to maintain duct static pressure

Modulating Heating Mode – Thermostat (up to 2 stages, W1 & W2)

W1 demand indicates heating operation. Supply fan operates to maintain Duct Static setpoint and Gas valves modulates up and down to maintain Discharge Air Temperature (DAT) setpoint as the blower speed changes. Once heating demand is satisfied W1 is deactivated.

Modulating Heating Mode – Zone Sensor

The Zone Air Temperature signal initiates heating operation. Supply fan operates to maintain Duct Static setpoint and Gas valves modulates up and down to maintain Discharge Air Temperature (DAT) setpoint as the blower speed changes. When the zone air temp has reached the setpoint, the heating operation is deactivated.

ACCESSORIES**Modulating Outdoor Air Damper**

The minimum damper position for “occupied low blower” and “occupied high blower” is adjusted during unit setup to provide minimum fresh air requirements. When supply air blower is off or the unit is in unoccupied mode, the outdoor air damper is closed.

- When unit is in occupied mode and supply air blower is operating at a speed below the “midpoint” blower speed, the outdoor air damper is at minimum “low blower” position.
- When unit is in occupied mode and supply air blower is operating at a speed equal to or above the “midpoint” blower speed, the outdoor air damper is at minimum “high blower” position.

NOTE - The “midpoint” blower speed is an average of the minimum and maximum blower speed ((minimum speed + maximum speed) divided by 2)

Power Exhaust

NOTE - POWER EXHAUST OPERATION IS THE SAME FOR ALL CONTROL OPTIONS

VAV models are equipped with 2-stage power exhaust fans . Power exhaust fans operate when economizer outdoor air dampers are 50% open (adjustable). Power exhaust operates in 1st stage (one fan) up to 70% of supply air blower speed. 2nd stage power exhaust fans (both fans) operate when supply air blower speed is above 70% (adjustable) of full speed.

Hot Gas Reheat Start-Up

General

Hot gas reheat units provide a dehumidifying mode of operation. These units contain a reheat coil adjacent to and downstream of the evaporator coil. Reheat coil solenoid valves, L14 and L30, route hot discharge gas from the compressor to the reheat coil. Return air pulled across the evaporator coil is cooled and dehumidified; the reheat coil adds heat to supply air.

See FIGURE 42 through FIGURE 44 for refrigerant routing.

L14 and L30 Reheat Coil Solenoid Valves

When Unit Controller (P298-5 or J299-8) indicates room conditions require dehumidification, See FIGURE 10 through 13. L14 and L30 reheat valves are energized (Unit Controller J394-1 or J394-3) and refrigerant is routed to the reheat coil.

Reheat Setpoint

Reheat is factory-set to energize when indoor relative humidity rises above 60% (default). The reheat setpoint can be adjusted by changing mobile service app *Settings* - *Control* menu. A setting of 100% will operate reheat from an energy management system digital output. The reheat setpoint can also be adjusted using an optional Network Control Panel (NCP).

Reheat will terminate when the indoor relative humidity falls 3% (57% default) or the digital output de-energizes. The reheat deadband can be adjusted at Settings - Control menu.

A91 Humidity Sensor

Relative humidity should correspond to the sensor (A91) output voltage listed in table 20. For example: if indoor air relative humidity is 80% \pm 3%, the humidity sensor output should read 8.00VDC.

Check the sensor output annually for accuracy. Keep the air intake openings on the sensor clean and free of obstructions and debris.

TABLE 24

Relative Humidity (%RH + 3%)	Sensor Output (VDC)
20	2.00
30	3.00
40	4.00
50	5.00
60	6.00
70	7.00
80	8.00
90	9.00

Check-Out

Test hot gas reheat operation using the following procedure.

- 1 - Make sure reheat is wired as shown in wiring section.
- 2 - Make sure unit is in local thermostat mode.
- 3 - Use mobile service app menu path to select:

SERVICE > TEST > DEHUMIDIFIER

The blower, compressor 1 and compressor 2 (reheat) should be operating. Reheat mode will appear on the mobile service app display.

- 4 - Deselect:

SERVICE > TEST > DEHUMIDIFIER

Compressor 1 and 2 (reheat should de-energize, blower should still be energized).

Additional Cooling Stages

Units are shipped from the factory to provide two stages of cooling.

Compressors are not de-energized when unit operation changes from cooling to reheat or from reheat to cooling. Instead, L14 and L30 reheat valves are energized (reheat) or de-energized (cooling).

NOTE - Another thermostat staging option is available which allows both compressors to be energized during free cooling. See Unit Controller manual for details.

REFRIGERANT SCHEMATIC (156 MODEL ONLY)

NOTE - Two refrigerant circuits operate during reheat.

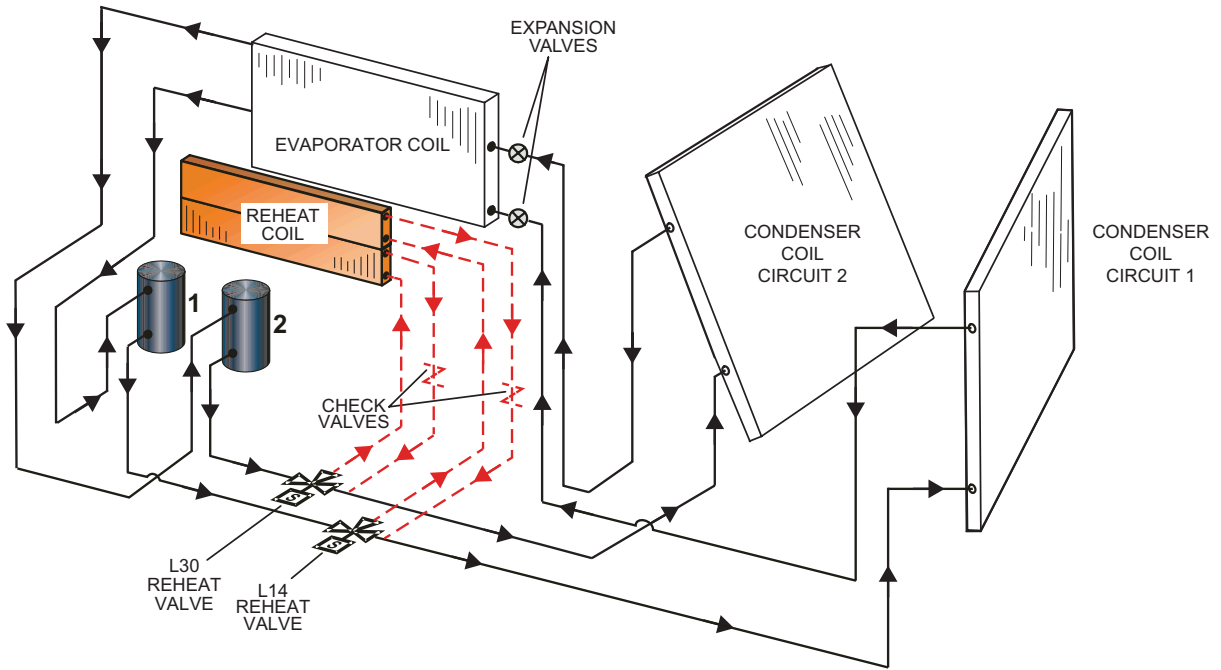

FIGURE 42

REFRIGERANT SCHEMATIC (180 MODEL ONLY)

NOTE - Two refrigerant circuits operate during reheat.

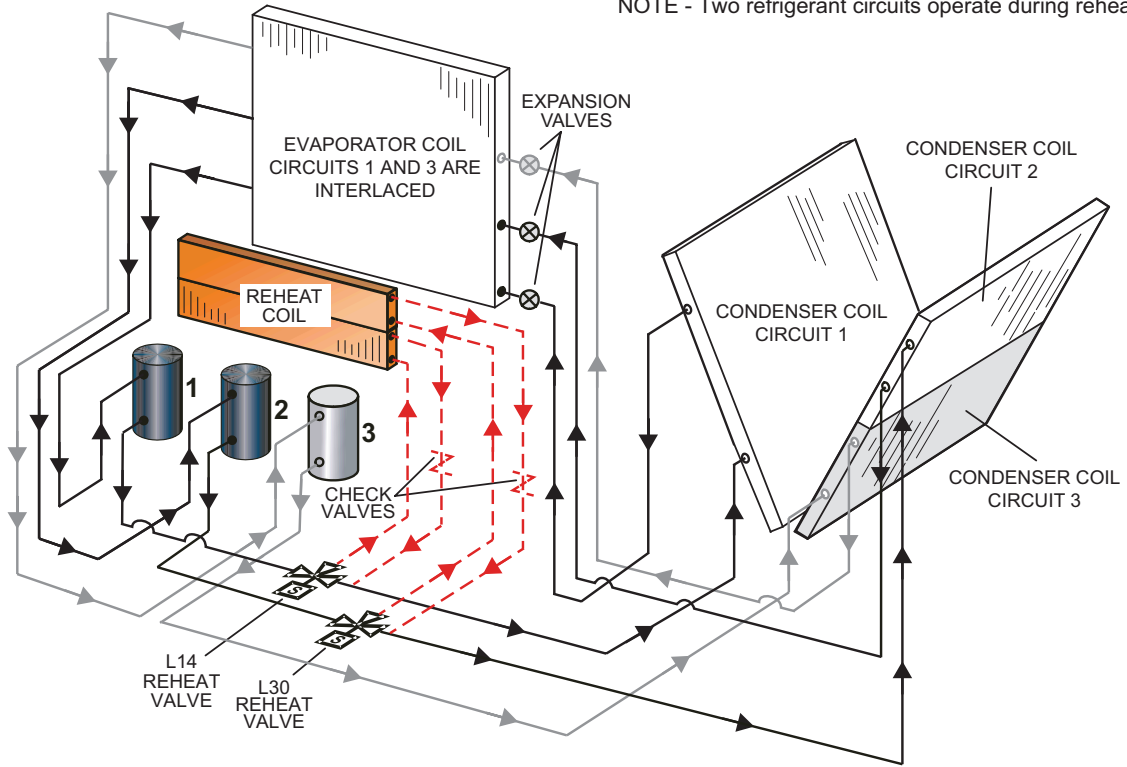

FIGURE 43

REFRIGERANT SCHEMATIC (210, 240 and 300 MODELS ONLY)

NOTE - Two refrigerant circuits operate during reheat.

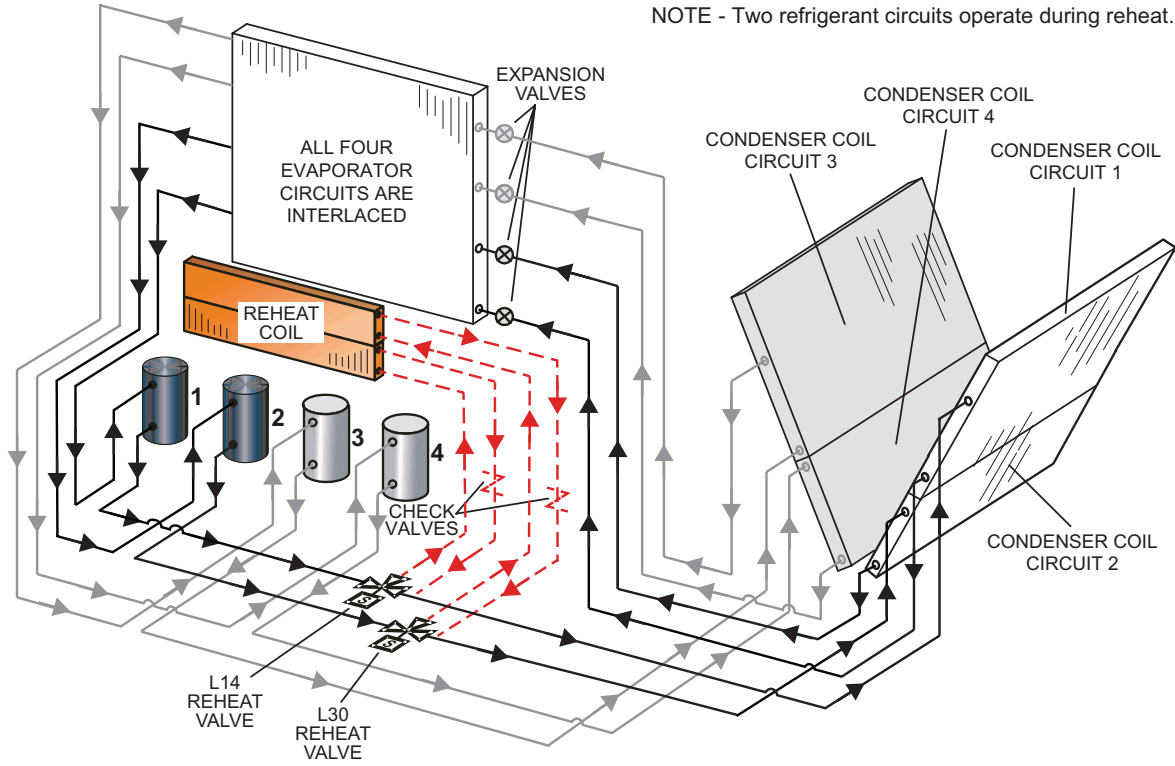

FIGURE 44

**TABLE 25
REHEAT OPERATION**

Thermostat Mode with 24V Humidistat	
Humidity Demands	Operation
24V Demand for Dehumidification Only	<ul style="list-style-type: none"> • Compressor 1 reheat on • Compressor 1 operates at 100% • Reheat valve is energized • Remaining compressors are staged based on discharge air temperature • Blower and outdoor fans modulate to maintain indoor coil and discharge air temperatures
24V Demand for Dehumidification only is still present after Five Minutes	<ul style="list-style-type: none"> • Compressor 1 & 2 reheat on • Compressor 1 operates at 100% • Reheat valves are energized • Remaining compressor(s) are staged based on discharge air temperature. • Blower and outdoor fans modulate to maintain indoor coil and discharge air temperatures
Thermostat Mode with Zone Relative Humidity (RH) Sensor	
Zone humidity is greater than Setpoint +2%	<ul style="list-style-type: none"> • Compressor 1 reheat on • Compressor 1 modulates to maintain zone RH • Reheat valve is energized • Remaining compressors are staged based on discharge air temperature. • Blower and outdoor fans modulate to maintain indoor coil and discharge air temperatures
Zone humidity is greater than Setpoint +2% OR Zone humidity is greater than Setpoint for 5 minutes	<ul style="list-style-type: none"> • Compressor 1 & 2 reheat on • Compressor 1 modulates to maintain zone RH • Reheat valves are energized • Remaining compressor(s) are staged based on discharge air temperature. • Blower and outdoor fans modulate to maintain indoor coil and discharge air temperatures

NOTE - Compressors are not engaged while unit is in re-heat mode. They will stage accordingly to maintain discharge air temperature.

Preventative Maintenance / Repair

IMPORTANT MAINTENANCE / REPAIR SAFETY INSTRUCTIONS

Prior to beginning work on systems containing FLAMMABLE REFRIGERANTS, safety checks are necessary to ensure that the risk of ignition is minimized.

Work shall be undertaken under a controlled procedure to minimize the risk of a flammable gas or vapor being present while the work is being performed.

All maintenance staff and others working in the local area shall be instructed on the nature of work being carried out. Work in confined spaces shall be avoided.

The area shall be checked with an appropriate refrigerant detector prior to and during work, to ensure the technician is aware of potentially toxic or flammable atmospheres. Ensure that the leak detection equipment being used is suitable for use with all applicable refrigerants, i.e. non-sparking, adequately sealed or intrinsically safe.

If any hot work is to be conducted on the refrigerating equipment or any associated parts, appropriate fire extinguishing equipment shall be available to hand. Have a dry powder or CO2 fire extinguisher adjacent to the charging area.

No person carrying out work in relation to a REFRIGERATING SYSTEM which involves exposing any pipe work shall use any sources of ignition in such a manner that it may lead to the risk of fire or explosion. All possible ignition sources, including cigarette smoking, should be kept sufficiently far away from the site of installation, repairing, removing and disposal, during which refrigerant can possibly be released to the surrounding space. Prior to work taking place, the area around the equipment is to be surveyed to make sure that there are no flammable hazards or ignition risks. "No Smoking" signs shall be displayed.

Where electrical components are being changed, they shall be fit for the purpose and to the correct specification. At all times, the manufacturer's maintenance and service guidelines shall be followed. If in doubt, consult the manufacturer's technical department for assistance.

Repair and maintenance to electrical components shall include initial safety checks and component inspection procedures. If a fault exists that could compromise safety, then no electrical supply shall be connected to the circuit until it is satisfactorily dealt with. If the fault cannot be corrected immediately but it is necessary to continue operation, an adequate temporary solution shall be used. This shall be reported to the owner of the equipment so all parties are advised.

Initial safety checks shall include:

- that capacitors are discharged: this shall be done in a safe manner to avoid possibility of sparking
- that no live electrical components and wiring are exposed while charging, recovering or purging the system
- that there is continuity of earth bonding

The following checks shall be applied to installations using FLAMMABLE REFRIGERANTS:

- the actual REFRIGERANT CHARGE is in accordance with the room size within which the refrigerant containing parts are installed;
- the ventilation machinery and outlets are operating adequately and are not obstructed;
- if an indirect refrigerating circuit is being used, the secondary circuit shall be checked for the presence of refrigerant;
- marking to the equipment continues to be visible and legible. Markings and signs that are illegible shall be corrected;
- refrigerating pipe or components are installed in a position where they are unlikely to be exposed to any substance which may corrode refrigerant containing components, unless the components are constructed of materials which are inherently resistant to being corroded or are suitably protected against being so corroded.

During repairs to sealed electrical components, the components shall be replaced. Replacement parts shall be in accordance with the manufacturer's specifications.

During repairs to intrinsically safe components, the components must be replaced. Replace components only with parts specified by the manufacturer. Other parts may result in the ignition of refrigerant in the atmosphere from a leak.

The unit should be inspected once a year by a qualified service technician.

A-Filters

Units are equipped with six 24 X 24 X 2" filters. Filters should be checked monthly and replaced when necessary with filters of like kind and size. Take note of air flow direction marking on filter frame when reinstalling filters. See FIGURE 45.

NOTE - Filters must be U.L.C. certified or equivalent for use in Canada.

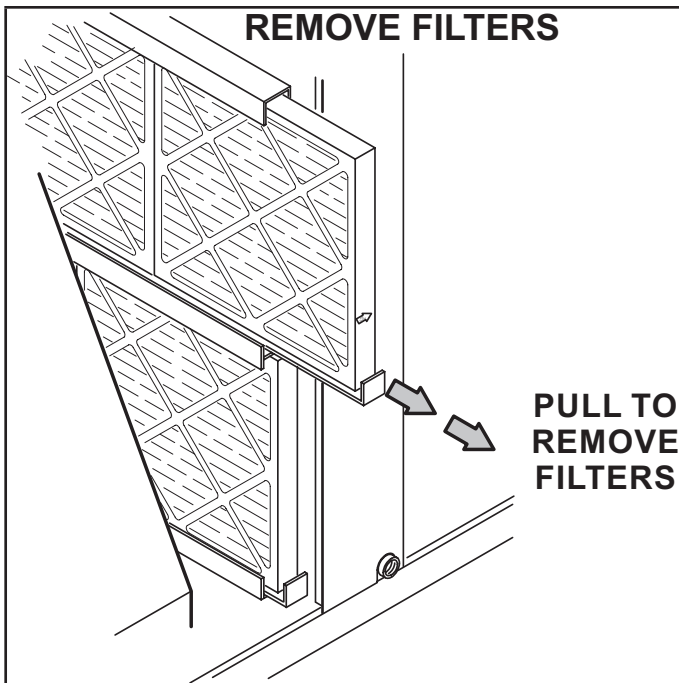

FIGURE 45

⚠ CAUTION

Label all wires prior to disconnection when servicing controls. Wiring errors can cause improper and dangerous operation. Verify proper operation after servicing.

B-Lubrication

All motors are lubricated at the factory. No further lubrication is required.

Blower shaft bearings are prelubricated. For extended bearing life, relubricate at least once every two years with a lithium base grease, such as Alvania 3 (Shell Oil), Chevron BRB2 (Standard Oil) or Regal AFB2 (Texas Oil). Use a hand grease gun for relubrication. Add only enough grease to purge through the bearings so that a bead of grease appears at the seal lip contacts.

C-Burners (Gas Units)

Periodically examine burner flames for proper appearance during the heating season. Before each heating season examine the burners for any deposits or blockage which may have occurred.

Clean burners as follows:

- 1 - Turn off both electrical power and gas supply to unit.
- 2 - Open burner compartment access panel.
- 3 - Remove screws securing burner assembly to burner support and remove assembly. See FIGURE 46. Clean as necessary.
- 4 - Locate the ignitor under the left burners. Check ignitor spark gap with appropriately sized twist drills or feeler gauges. See FIGURE 47.
- 5 - Check the alignment of the ignitor and the sensor as shown in FIGURE 47 and TABLE 26.
- 6 - Replace burners and screws securing burner.
- 7 - Replace access panel.
- 8 - Restore electrical power and gas supply. Follow lighting instructions attached to unit and use inspection port in access panel to check flame.

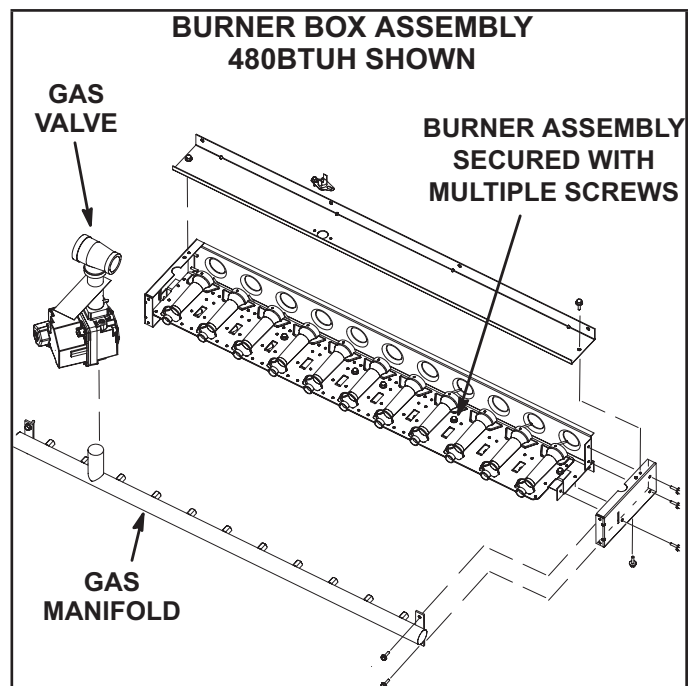

FIGURE 46

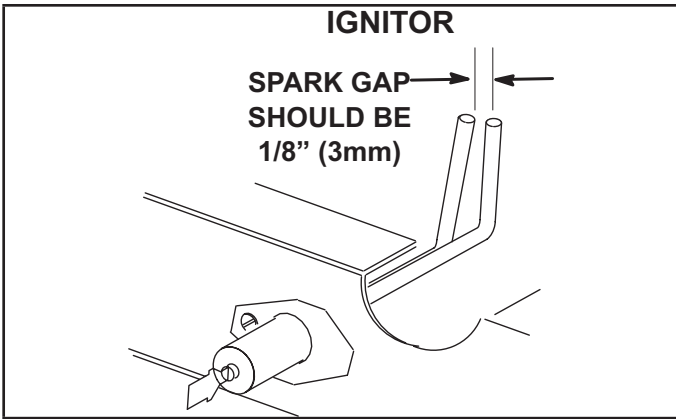

FIGURE 47

TABLE 26			
Dimension	Unit Btuh Input	Length - in. (mm)	
		Ignitor	Sensor
A	260K	7-3/4 (197)	11 (279)
B	360K	5 (127)	5-1/2 (140)
C	480K	2-1/4 (57)	2-3/4 (70)

D-Combustion Air Inducer (Gas Units)

A combustion air proving switch checks combustion air inducer operation before allowing power to the gas controller. Gas controller will not operate if inducer is obstructed.

Under normal operating conditions, the combustion air inducer wheel should be checked and cleaned prior to the heating season. However, it should be examined periodically during the heating season to establish an ideal cleaning schedule. With power supply disconnected, the condition of the inducer wheel can be determined by looking through the vent opening.

Clean combustion air inducer as follows:

- 1 - Shut off power supply and gas to unit.
- 2 - Disconnect pressure switch air tubing from combustion air inducer port.
- 3 - Remove and retain screws securing combustion air inducer to flue box. Remove and retain two screws from bracket supporting vent connector. See FIGURE 49.
- 4 - Clean inducer wheel blades with a small brush and wipe off any dust from housing. Clean accumulated dust from front of flue box cover.
- 5 - Return combustion air inducer motor and vent connector to original location and secure with retained screws. It is recommended that the combustion air inducer gasket be replaced during reassembly.
- 6 - Clean combustion air inlet louvers on heat access panel using a small brush.

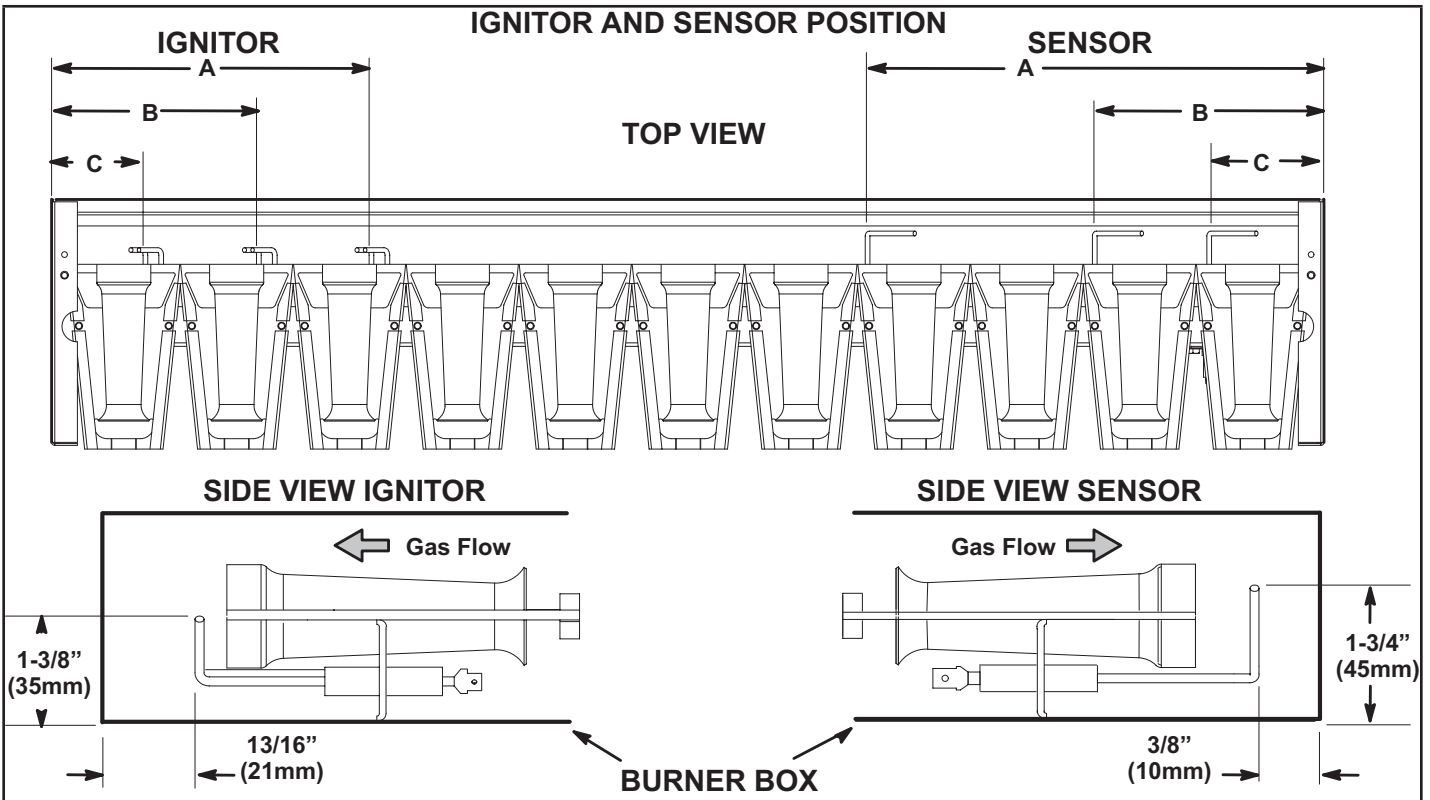

FIGURE 48

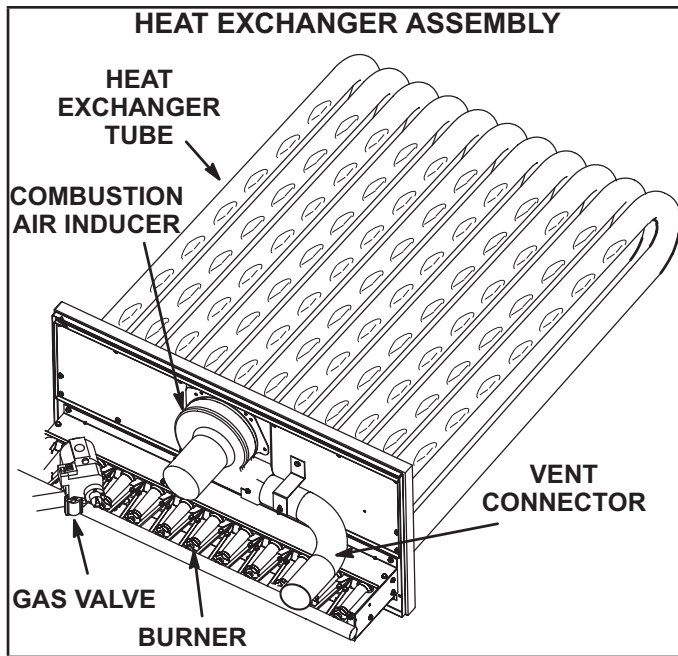

FIGURE 49

E-Replacement Fuses

See the following tables for the proper replacement fuse sizes.

ELECTRIC HEAT REPLACEMENT FUSES				
	Electric Heat	Qty.	Rating	
			Amp	Volt
1	E1EH0050N-1P	2	30	250
2	T1/E1EH0075AN1Y	3	25	250
3	E1EH0100N-1P	4	30	250
4	T1/E1EH0150AN1Y	3	50	250
5	T1/E1EH0225AN1Y	6	45	250
6	T1/E1EH0300N-1Y	6	60	250
7	E2EH0300N-1Y	6	60	250
8	K1EH0050A-1P	2	30	250
9	T1/E1EH0075AN1P	2	40	250
10	T1EH0100A-1P	4	30	250
11	T1/E1EH0150AN1P	4	40	250
12	T1/E1EH0225AN1P	6	40	250
13	T1/E1EH0075AN1J	3	15	600
14	T1/E1EH0150AN1J	3	20	600
15	T1/E1EH0225AN1J	3	30	600
16	T1/E1EH0300N-1J	3	40	600
17	T1/E1EH0075AN1G	3	15	600
18	T1/E1EH0150AN1G	3	25	600
19	T1/E1EH0225AN1G	3	35	600
20	T1/E1EH0300N-1G	3	50	600
21	K1/E1EH0057AN1M	3	15	600
22	K1/E1EH0115AN1M	3	20	600
23	K1EH0172AN1M	3	30	600
24	E1EH0172N-1M	3	30	600
25	K1/E1EH0230N-1M	3	40	600

UNIT REPLACEMENT FUSES										
LGT/LCT156										
Unit Voltage			208V - 3 Ph		240V - 3 Ph		480V - 3Ph		600V - 3 Ph	
Power Exhaust Option			W / P.E.	W / O P.E.	W / P.E.	W / O P.E.	W / P.E.	W / O P.E.	W / P.E.	W / O P.E.
Diagram Key	Class	Blower HP	Amps							
F10	CC	ALL	12 A	12 A	12 A	12 A	12 A	12 A	12 A	12 A
F61	J	ALL	For F61 Fuse, see MOP Value on nameplate.							
F57	CC	ALL	-	-	-	-	7.5 A	7.5 A	10 A	10 A
F58	CC	ALL	-	-	-	-	7.5 A	7.5 A	10 A	10 A

¹ When SCCR is installed, F4 fuse is Class J.

² Fuse F61 is only used on units with SCCR installed.

LGT/LCT180										
Unit Voltage			208V - 3 Ph		240V - 3 Ph		480V - 3Ph		600V - 3 Ph	
Power Exhaust Option			W / P.E.	W / O P.E.	W / P.E.	W / O P.E.	W / P.E.	W / O P.E.	W / P.E.	W / O P.E.
Diagram Key	Class	Blower HP	Amps							
F10	CC	ALL	12 A	12 A	12 A	12 A	12 A	12 A	12 A	12 A
F61	J	ALL	For F61 Fuse, see MOP Value on nameplate.							
F57	CC	ALL	-	-	-	-	7.5 A	7.5 A	10 A	10 A
F58	CC	ALL	-	-	-	-	7.5 A	7.5 A	10 A	10 A

¹ When SCCR is installed, F4 fuse is Class J.

² Fuse F61 is only used on units with SCCR installed.

LGT/LCT210										
Unit Voltage			208V - 3 Ph		240V - 3 Ph		480V - 3Ph		600V - 3 Ph	
Power Exhaust Option			W / P.E.	W / O P.E.	W / P.E.	W / O P.E.	W / P.E.	W / O P.E.	W / P.E.	W / O P.E.
Diagram Key	Class	Blower HP	Amps							
F10	CC	ALL	12 A	12 A	12 A	12 A	12 A	12 A	12 A	12 A
F61	J	ALL	For F61 Fuse, see MOP Value on nameplate.							
F57	CC	ALL	-	-	-	-	7.5 A	7.5 A	10 A	10 A
F58	CC	ALL	-	-	-	-	7.5 A	7.5 A	10 A	10 A

¹ When SCCR is installed, F4 fuse is Class J.

² Fuse F61 is only used on units with SCCR installed.

LGT/LCT240										
Unit Voltage			208V - 3 Ph		240V - 3 Ph		480V - 3Ph		600V - 3 Ph	
Power Exhaust Option			W / P.E.	W / O P.E.	W / P.E.	W / O P.E.	W / P.E.	W / O P.E.	W / P.E.	W / O P.E.
Diagram Key	Class	Blower HP	Amps							
F10	CC	ALL	30 A	30 A	30 A	30 A	12 A	12 A	12 A	12 A
F61	J	ALL	For F61 Fuse, see MOP Value on nameplate.							
F57	CC	ALL	-	-	-	-	7.5 A	7.5 A	10 A	10 A
F58	CC	ALL	-	-	-	-	7.5 A	7.5 A	10 A	10 A

¹ When SCCR is installed, F4 fuse is Class J.

² Fuse F61 is only used on units with SCCR installed.

LGT/LCT300										
Unit Voltage			208V - 3 Ph		240V - 3 Ph		480V - 3Ph		600V - 3 Ph	
Power Exhaust Option			W / P.E.	W / O.P.E.	W / P.E.	W / O.P.E.	W / P.E.	W / O.P.E.	W / P.E.	W / O.P.E.
Diagram Key	Class	Blower HP	Amps							
F10	CC	ALL	30 A	30 A	30 A	30 A	12 A	12 A	12 A	12 A
F61	J	ALL	For F61 Fuse, see MOP Value on nameplate.							
F57	CC	ALL	-	-	-	-	7.5 A	7.5 A	10 A	10 A
F58	CC	ALL	-	-	-	-	7.5 A	7.5 A	10 A	10 A

¹ When SCCR is installed, F4 fuse is Class J.

² Fuse F61 is only used on units with SCCR installed.

F-Flue Passageway and Flue Box (Gas Units)

- 1 - Remove combustion air inducer assembly as described in section D.
- 2 - Remove flue box cover. Clean with a wire brush as required.
- 3 - Clean tubes with a wire brush.
- 4 - Reassemble the unit. The flue box cover gasket and combustion air inducer gasket should also be replaced during reassembly.

G-Evaporator Coil

Inspect and clean coil at beginning of each cooling season. Clean using mild detergent or commercial coil cleaner. Flush coil and condensate drain with water taking care not to get insulation, filters and return air ducts wet.

H-Supply Air Blower Wheel

Annually inspect supply air blower wheel for accumulated dirt or dust. Turn off power before attempting to remove access panel or to clean blower wheel.

I-Condenser Coil

Clean condenser coil annually with detergent or commercial coil cleaner and inspect monthly during the cooling season. Access panels are provided on front and back of condenser section.

J-Needlepoint Bipolar Ionizer

The optional, brush-type ionizer produces positive and negative ions to clean air and reduce airborne contaminants. The ionizer was designed to be low maintenance. The device should be checked semi-annually to confirm the brushes are clean for maximum output. The ionizer is located behind the filters. See FIGURE 50.

- 1 - Remove filters, screws securing the top and bottom of the upper filter bracket, and the wire ties the screws hold in place. See FIGURE 50.
- 2 - Disconnect the ionizer plug near the top of the filter rack.
- 3 - Pull ionizer out of unit and clean brushes.
- 4 - Replace ionizer, reconnect ionizer plug, and replace filters, screws, and wire ties.

INSTALL IONIZER - 156-300

**20 TON SHOWN
(5 IONIZERS)**

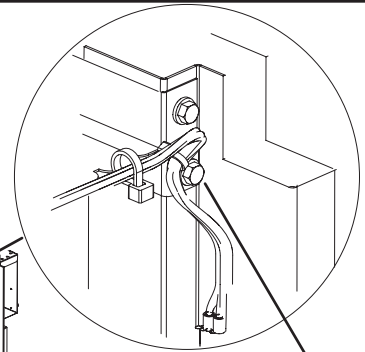

**REMOVE THE SCREW
SECURING THE TOP
OF THE UPPER FILTER
RACK BRACKET**

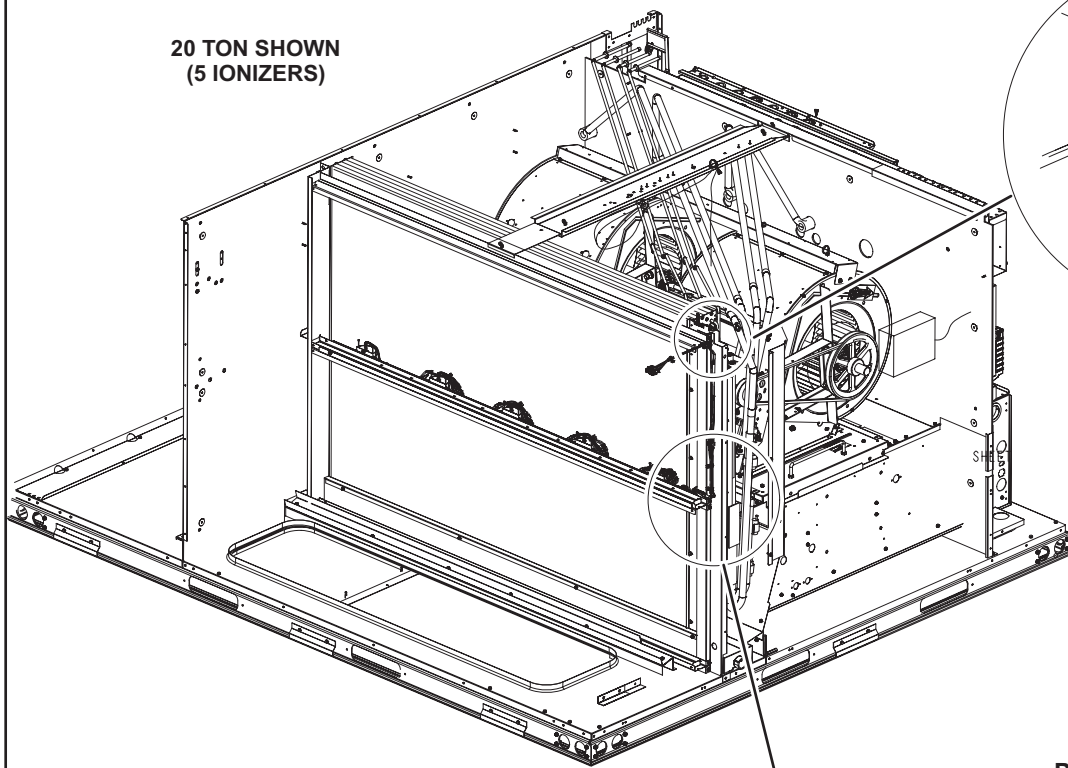

**ONE EDGE
PROTECTOR ON
IONIZER BRACKET**

**EVAPORATOR
COIL**

**TWO EDGE
PROTECTORS ON
FILTER RACK**

**REMOVE THE
SCREW SECURING
THE BOTTOM
OF THE UPPER FILTER
RACK BRACKET**

**IONIZER
BRACKET**

**UPPER FILTER
BRACKET
U-CHANNEL**

**SLIDE IONIZER BRACKET
BETWEEN UPPER AND LOWER
FILTER BRACKET U-CHANNELS**

**LOWER FILTER
BRACKET**

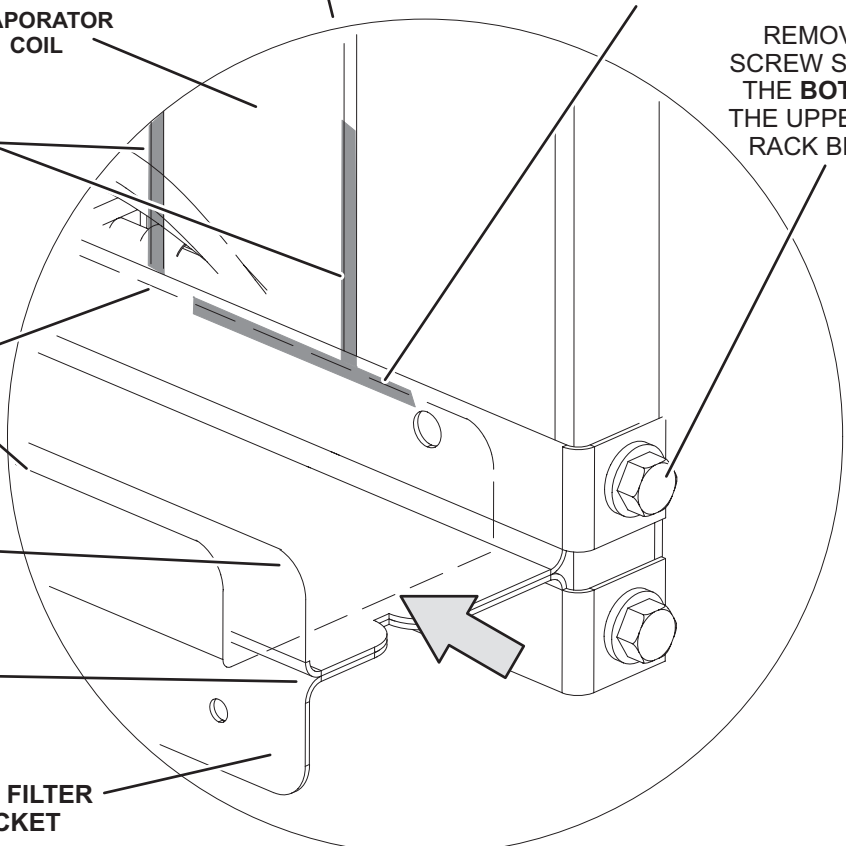

FIGURE 50

K-UVC Light (Optional)

When field-installed, use only UVC Light Kit assembly 106883-01 (21A94) with this appliance.

Factory-Installed UVC Light

When the UVC light is factory installed, the lamp is shipped in a foam sleeve. The lamp is attached to the UVC light assembly on the blower deck. Remove the lamp and install into the UVC light assembly as shown in steps 2 through 11 as follows.

Annual Lamp Replacement

WARNING

Personal Burn Hazard

Personal injury may result from hot lamps. During replacement, allow lamp to cool for 10 minutes before removing lamp from fixture.

The lamp should be replaced every 12 months, as UVC energy production diminishes over time.

- 1 - Obtain the correct model germicidal light replacement lamp 101087-02.
- 2 - Disconnect power to the rooftop unit before servicing the UVC kit.
- 3 - Open the blower access door.
- 4 - Disconnect the UVC cable quick connects (black/white).
- 5 - Remove and retain the (3) mounting screws securing the UVC assembly. Carefully remove the complete UVC assembly out through the blower access door. See FIGURE 52.

6 - Allow 10 minutes before touching the lamps. Then, carefully remove the lamp splash guards (and lamp for annual replacement) from each of the lamp holders. See FIGURE 51.

7 - Wear cotton gloves or use a cotton cloth when handling the new lamp. Gently but firmly push in the splash guards on each end of the lamp. Align and insert the lamp with splash guard into the lamp holders of the UVC assembly until each end clicks into place.

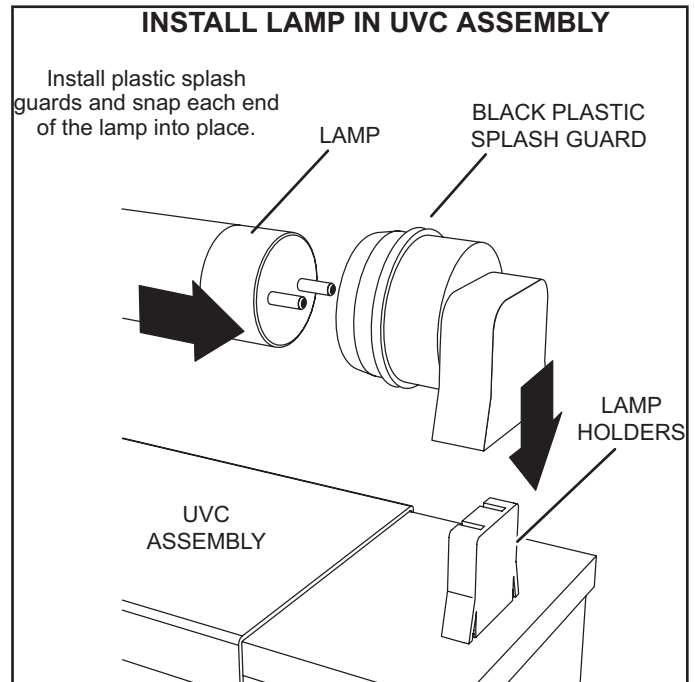

FIGURE 51

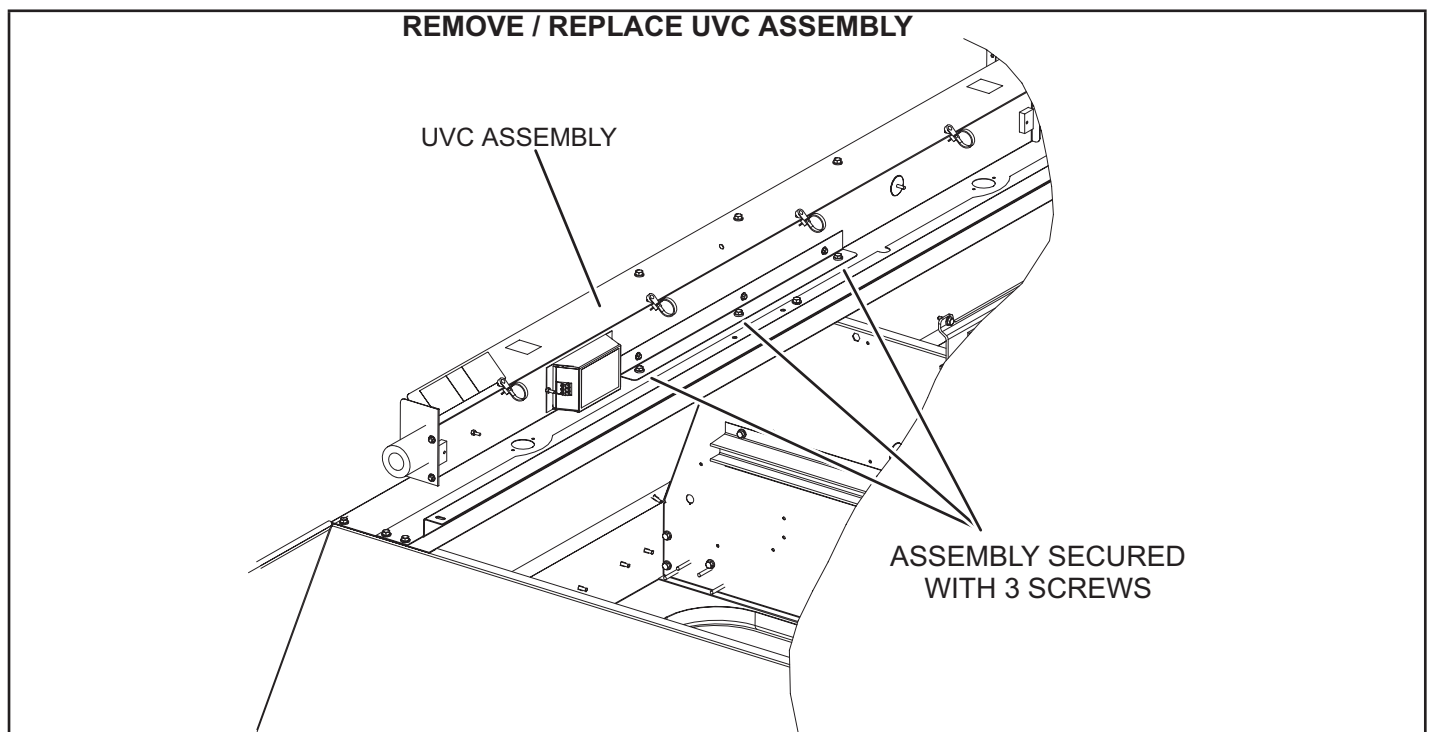

FIGURE 52

- 8 - Carefully place the UVC assembly on the blower deck. Line up the mounting holes on the UVC assembly with the mounting holes on the blower deck. Use the retained #10 screws to attach the UVC assembly in place.
- 9 - Close the blower access door.
- 10 -Reconnect power to the rooftop unit.
- 11 -Open the filter access door and look through the view port in the triangular sheet-metal panel to verify that the UVC light is on.

For all maintenance, contact a licensed HVAC technician.

If UVC lamp does not come on:

- 1 - Check Power Wiring: Disconnect 1/4" QC (quick connects) of the UVC cable near the UVC assembly. With Power ON, use multimeter to test 110-230V at the 1/4"QC quick connects from the control panel.
- 2 - Check Lamp: Carefully remove the UVC assembly out of the rooftop unit. Use multimeter to test for continuity across each pair of pins at each end of the lamp.
- 3 - Check Lamp Installation: Make sure that lamp's pins snap properly into the lamp holder.

Lamp Disposal

NOTE - UV Lamp Contains Mercury. Dispose According to Local, State, or Federal Laws.

Proper Clean-up Technique in Case of Lamp Breakage
Wear protective gloves, eye wear and mask.

Sweep the broken glass and debris into a plastic bag, seal the bag, and dispose of properly. Contact your local waste management office for proper disposal.

Do not use a vacuum cleaner. Do not incinerate.

Maintenance

- For all maintenance, contact a qualified HVAC technician.
- Read the maintenance instructions before opening unit panels.
- Unintended use of the unit or damage to the unit housing may result in the escape of dangerous UVC radiation. UVC radiation may, even in small doses, cause harm to the eyes and skin.
- Do not operate units that are obviously damaged.
- Do not discard the triangular UVC light shield or any barriers with an ultraviolet radiation symbol.
- Do not override the door interlock switch that interrupts power to the UVC light.
- Do not operate the UVC light outside of the unit.

Factory Unit Controller Settings

Use the mobile service app to adjust parameters; menu paths are shown in each table. Refer to the Unit Controller manual provided with each unit.

TABLE 27 through TABLE 31 show factory settings (in degrees, % of fan CFM, etc.). Record adjusted settings on the label located inside the compressor access panel.

When field installing optional kits and accessories, the Unit Controller must be configured to identify the option before it will function. Refer to FIGURE 53 and FIGURE 54 to determine whether the Unit Controller configuration I.D. must change. To configure the option, use MAIN MENU > SETUP > INSTALL menu path. Press SAVE until CONFIGURATION ID 1 or 2 appears depending on the option installed. Change the appropriate character in the configuration I.D. For example, when an economizer is installed using a single enthalpy sensor, change configuration I.D. 1, the second character, to "S".

TABLE 27 - 581038-01

Units With BACnet Module Settings
RTU Menu > Network Integration > Network Setup Wizard > BACnet MS/TP > See BACnet MAC Address
BACNET MAC ADDRESS:
Units With Room Sensor, CPC/LSE Gateway Settings
RTU Menu > Network Integration > Network Setup Wizard > SBUS > Set SBUS Address
LCONN ADDRESS:

TABLE 28 - 581024-01

Units With Hot Gas Reheat			
RTU Menu > Settings "RTU Options" > Dehumidifier			
Parameter	Factory Setting	Field Setting	Description
105	7		Factory Setting 7: Reheat mode enabled without prerequisite conditions. Controlled by RH sensor (A91) connected to input A55_P298_5 and set point set at parameter 106 (default 60%).

TABLE 29 - 581037-01

Units With LonTalk Settings
Use menu RTU Menu > Network Integration > Network Setup Wizard > Set "LONTALK"

TABLE 30 - 581025-01

LGT/LCT 156, 180, 210, 240, 300 Staged							
Parameter	Factory Setting					Field Setting	Description
	156	180	210	240	300		
Note: Any changes to Smoke CFM setting must be adjusted before the other CFM settings. Use SETTINGS > RTU OPTIONS > EDIT PARAMETERS							
12	5200 CFM	6000 CFM	7000 CFM	8000 CFM	10000 CFM	CFM	Blower CFM during smoke detection.
SETUP > TEST & BALANCE (can also use SETTINGS > RTU OPTIONS > BLOWER > SPEEDS)							
17	1150 CFM	1325 CFM	1550 CFM	1750 CFM	2200 CFM	CFM	Blower CFM during COOLING LOW operation.
14	4550 CFM	5250 CFM	6125 CFM	7000 CFM	8750 CFM	CFM	Blower CFM during COOLING HIGH operation.
13	5200 CFM	6000 CFM	7000 CFM	8000 CFM	10000 CFM	CFM	Blower CFM during Heating operation.
18	1150 CFM	1325 CFM	1550 CFM	1750 CFM	2200 CFM	CFM	Blower CFM during ventilation.
SETUP > TEST & BALANCE (can also use SETTINGS > RTU OPTIONS > DAMPER)							
9	0%	0%	0%	0%	0%	%	Damper min. position during LOW blower operation.
132	0%	0%	0%	0%	0%	%	Damper min. position during HIGH blower operation.
215	50%	50%	50%	50%	50%	%	Min. damper % for stg 1 power exhaust operation.
SETTINGS > RTU OPTIONS > EDIT PARAMETERS							
29	101%	101%	101%	101%	101%	%Open	Damper minimum position during G blower operation. (Setting parameter 29 to "101" disables parameter 29 and passes control to parameter 9 or 132)
219	75%	75%	75%	75%	75%	%	Min. damper % for stg 2 power exhaust operation.
216	10%	10%	10%	10%	10%	%	Deadband % for stage 1 power exhaust operation.
220	10%	10%	10%	10%	10%	%	Deadband % for stage 2 power exhaust operation.
224	100	100	100	100	100	Sec	Stage 1 power exhaust off-delay in seconds.
30	70%	70%	70%	70%	70%	%Speed	Minimum blower speed % for stage 2 power exhaust operation.

TABLE 31 - 581026-01

LGT/LCT 156-300 - VAV - Test and Balance Settings			
Parameter	Factory Setting	Field Setting	Description
Use SETTINGS > RTU OPTIONS > EDIT PARAMETERS			
386	1	W.C.	
SETUP > TEST & BALANCE > (can also use SETTINGS > RTU OPTIONS > BLOWER > SPEEDS)			
	1	W.C.	
SETUP > TEST & BALANCE (can also use SETTINGS > RTU OPTIONS > DAMPER) (Optional)			
132	0%	%	Damper min. position during blower operation.
215	50%	%	Min. damper % for stage 1 power exhaust operation.
219	75%	%	Min. damper % for stage 2 power exhaust operation.
217	0.05	W.C.	Pressure setpoint for stage 1 power exhaust operation.
221	0.10	W.C.	Pressure setpoint for stage 2 power exhaust operation.
29	101%	%Open	Damper minimum position during G blower operation. (Setting parameter 29 to "101" disables parameter 29 and passes control to parameter 9 or 132)

Configuration ID 1

1 2 3 4 5 6 7 8

Humiditrol [1]

Not Installed = **N**
 Humiditrol Installed = **H**
 Unconfigured = **U**

Economizer [2]

Not Installed = **N**
 Motorized Outdoor Air
 Damper Only = **M**
 Economizer - Temperature = **T**
 Economizer Global = **G**
 Economizer - Single
 Enthalpy = **S**
 Economizer - Dual Enthalpy = **D**
 Unconfigured = **U**

Power Exhaust [3]

Not Installed = **N**
 Single-Stage = **S**
 Dual-Stage = **D**
 Unconfigured = **U**

Power Exhaust Control [4]

Not Installed = **N**
 Damper Position = **A**
 A34 Pressure Sensor = **C**

[8] Outdoor Air CFM Control

N = Not applicable (for future use)
L = Outdoor Air Control Installed with A24 Sensor set for low range.
M = Outdoor Air Control Installed with A24 Sensor set for medium range.
H = Outdoor Air Control Installed with A24 Sensor set for high range.

[7] System Blower Subtype

N = Not applicable
B = VFD Belt Drive Blower (MODBUS)
H = Direct-Plus Blower (MODBUS)
L = ECM Direct-Drive Blower (PWM)

[6] Blower Variable Frequency Drive Bypass

N = Not Installed
A = Automatic Bypass
M = Manual Bypass
U = Unconfigured

[5] Network Module

N = Not Installed
L = LonTalk (Lennox)

FIGURE 53

Configuration ID 2

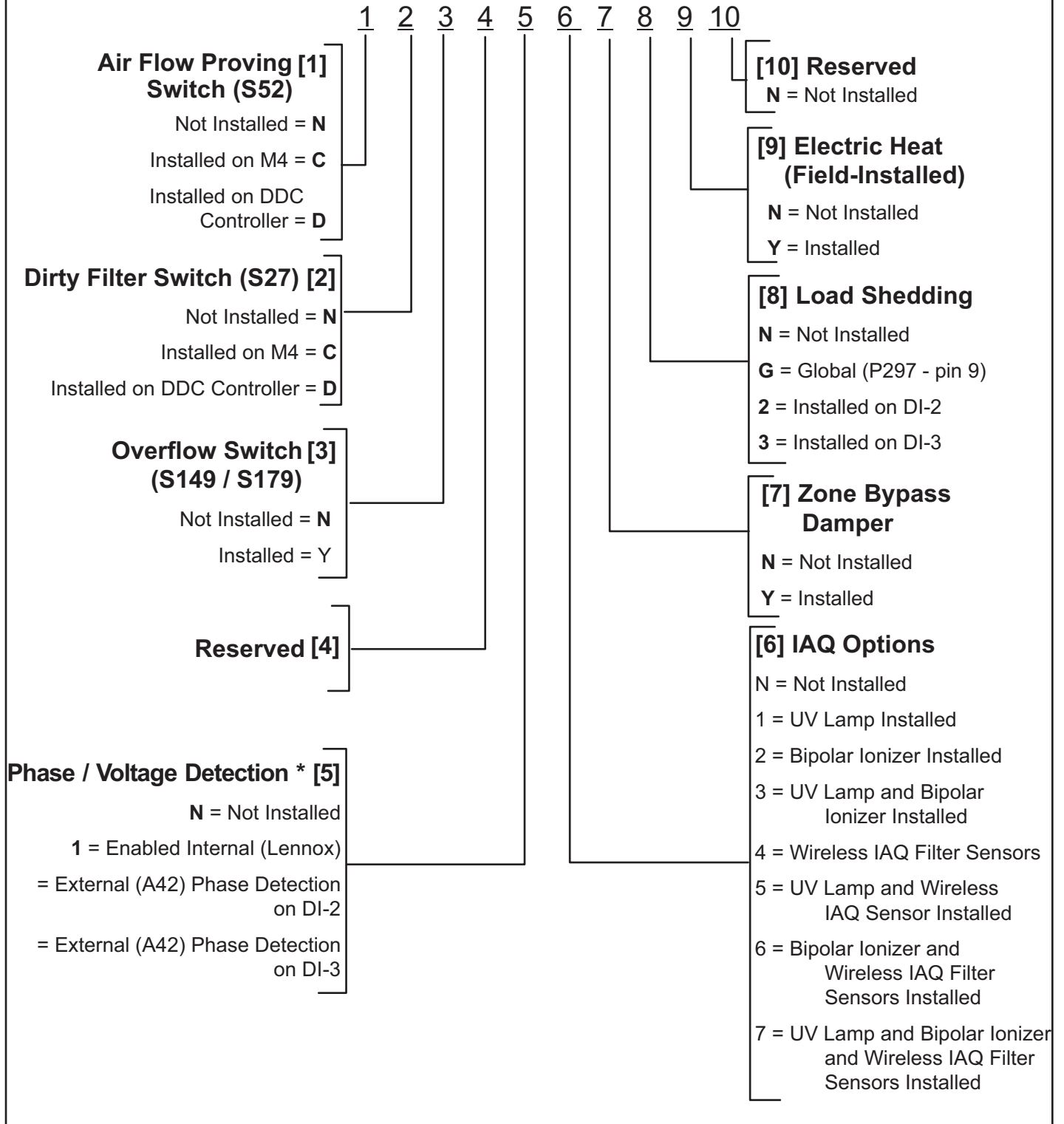

FIGURE 54

Decommissioning

Before carrying out this procedure, it is essential that the technician is completely familiar with the equipment and all its detail. It is recommended good practice that all refrigerants are recovered safely.

Prior to the task being carried out, an oil and refrigerant sample shall be taken in case analysis is required prior to re-use of recovered refrigerant. It is essential that electrical power is available before starting decommissioning.

- a) Become familiar with the equipment and its operation.
- b) Isolate system electrically.
- c) Before attempting the procedure, ensure that:
 - mechanical handling equipment is available, if required, for handling refrigerant cylinders;
 - all personal protective equipment is available and being used correctly;
 - the recovery process is supervised at all times by a competent person;
 - recovery equipment and cylinders conform to the appropriate standards.
- d) Pump down refrigerant system, if possible.
- e) If a vacuum is not possible, make a manifold so that refrigerant can be removed from various parts of the

system.

- f) Make sure that cylinder is situated on the scales before recovery takes place.
- g) Start the recovery machine and operate in accordance with instructions.
- h) Do not overfill cylinders (no more than 80% volume liquid charge).
- i) Do not exceed the maximum working pressure of the cylinder, even temporarily.
- j) When the cylinders have been filled correctly and the process completed, make sure that the cylinders and the equipment are removed from site promptly and all isolation valves on the equipment are closed off.
- k) Recovered refrigerant shall not be charged into another REFRIGERATING SYSTEM unless it has been cleaned and checked.

IMPORTANT

Equipment shall be labelled stating that it has been decommissioned and emptied of refrigerant. The label shall be signed and dated. Ensure that there are labels on the equipment that state the flammability of the refrigerant used.

START-UP REPORT

Job Name: _____
 Store No. _____ Start-Up Date: _____
 Address: _____
 City: _____ State: _____
 Start-Up Contractor: _____
 Technician: _____
 Model No.: _____
 Serial No.: _____
 RTU No.: _____ Catalog No.: _____

Inspections and Checks			
Damage?	Yes	No	R454B <input type="checkbox"/>
If yes, reported to: _____			
Verify factory and field-installed accessories.			
Check electrical connections. Tighten if necessary.			
Supply voltage: L1-L2 _____ L1-L3 _____ L2-L3 _____			
If unit contains a 208-230/240 volt transformer:			
Check primary transformer tap <input type="checkbox"/>			
Transformer secondary voltage: _____			

Cooling Checks												
Compressor Rotation <input type="checkbox"/> Ambient Temp. _____ Return Air Temp. _____ Supply Air Temp. _____												
	Compressor Amps			Compressor Volts			Pressures		Condenser Fan Amps			CC Heater Amps
	L1	L2	L3	L1-L2	L1-L3	L2-L3	Disch.	Suct.	L1	L2	L3	L1
1												
2												
3												
4												

Blower Checks			
Pulley/Belt Alignment <input type="checkbox"/>	Blower Rotation <input type="checkbox"/>		
Set Screws Tight <input type="checkbox"/>	Belt Tension <input type="checkbox"/>		
Nameplate Amps: _____		Volts: _____	
Motor	Amps	Volts	
	L1 _____	L1-L2 _____	
	L2 _____	L1-L3 _____	
	L3 _____	L2-L3 _____	

Heating Checks - Electric							
Return Air Temp.: _____ Supply Air Temp.: _____							
Limits Operate: <input type="checkbox"/>							
	Amps						
	L1	L2	L3		L1	L2	L3
1				10			
2				11			
3				12			
4				13			
5				14			
6				15			
7				16			
8				17			
9				18			

Heating Checks - Gas		
Fuel type: Nat. <input type="checkbox"/> LP <input type="checkbox"/> Inlet Pressure: _____ in. w.c.		
Return Air Temp.: _____ Supply Air Temp.: _____		
Altitude: _____ Primary Limits Operate: <input type="checkbox"/>		
CO ₂ %: _____		
Gas Valve	Manifold Pressure	
	Low Fire	High Fire
GV1		
GV2		

Accessory Checks	
Power Exhaust Amps	
1 _____	2 _____ None <input type="checkbox"/>
Economizer Operation	
Min. Pos. <input type="checkbox"/>	Motor travel full open/close <input type="checkbox"/>

Control Type