

ML296UHV(K)

MERIT® SERIES

Upflow / Horizontal | Two-Stage Heat | Variable Speed Blower | Refrigerant Detection | 60Hz

RESIDENTIAL
PRODUCT SPECIFICATIONS (EHB)



AFUE - 96%

Input - 44,000 to 110,000 Btuh

Nominal Add-on Cooling - 3 to 5 Tons

MERIT® SERIES





QUALIFIED ONLY IN
U.S. SOUTH: AL, AZ, AR, CA, DC, DE, FL, GA, HI, KY, LA, MD, MS, NV, NM, NC, OK, SC, TN, TX, VA



■ QUALIFIED

MODEL NUMBER IDENTIFICATION

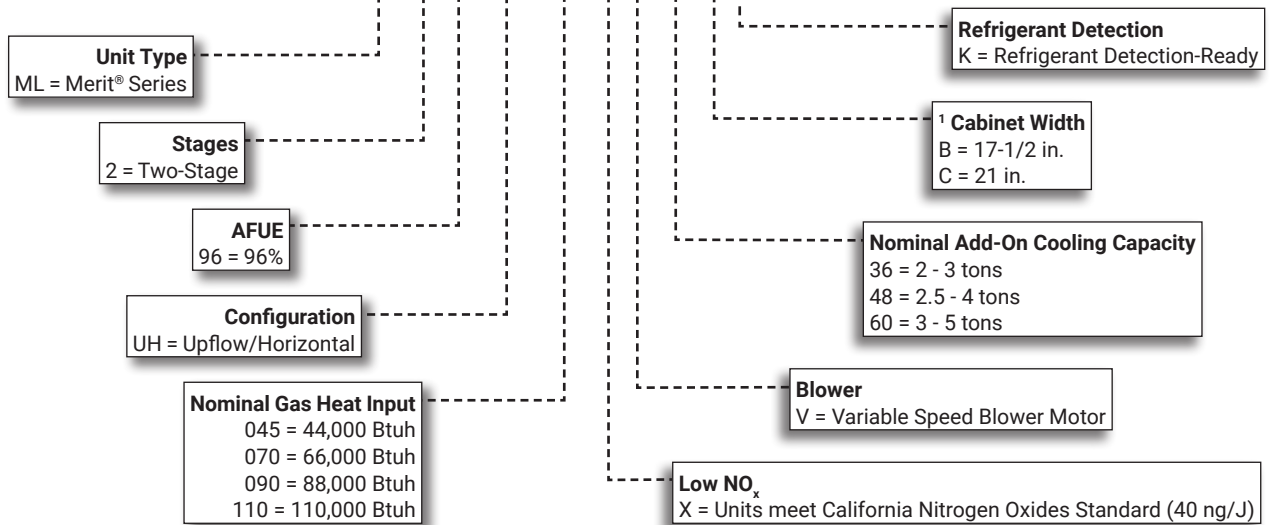
ML 2 96 UH 070 X V 36 B K



¹ Indoor coils with the same letter designation physically matches the furnace.

FEATURE HIGHLIGHTS

1. Lennox Duralok Plus™ Heat Exchanger
2. Secondary Heat Exchanger
3. Inshot Burners
4. SureLight® Hot Surface Ignitor
5. Two-Stage Gas Control Valve
6. Two-Speed Combustion Air Inducer
7. Flame Rollout Switches
8. SureLight® Integrated Furnace Control
9. Variable Speed Direct Drive Blower
10. Insulated Cabinet
11. Safety Interlock Switch
12. Gas Piping And Electrical Inlets



NOTE - ML296UHV(K) FURNACES CANNOT BE TWINNED!

CONTENTS

Approvals And Warranty	3
Blower Data	25
Control Options	10
Dimensions - Furnace/Coil Combined Dimensions	21
Dimensions - Optional Accessories	20
Dimensions - Optional Accessories - Venting	22
Dimensions - Unit - Horizontal Position	19
Dimensions - Unit - Upflow Position	18
Features	3
Gas Heat Accessories	14
High Altitude Derate	14
Indoor Air Quality Product Options	10
Installation Clearances	13
Optional Accessories	13
Specifications	12
Vent Lengths - Uninsulated Exhaust Pipe In Unconditioned Space	15

APPROVALS AND WARRANTY

APPROVALS

- AHRI Certified
- Certified by CSA International
- Tested and rated according to US DOE test procedures and FTC labeling regulations
- ENERGY STAR® units are certified only in the U.S. South in certain states and are designed to use less energy, help save money on utility bills, and help protect the environment
- ISO 9001 Registered Manufacturing Quality System
- Blower data from unit tests conducted in Lennox Laboratory air test chamber
- All models meet UL 60335-2-40 Refrigerant Detector Requirements

NOTE - This furnace has not been CSA International design certified for installation in mobile homes, recreational vehicles, or outdoors.

California Only

- These furnaces **do not meet** the South Coast Air Quality Management District (SCAQMD) Rule 1111 and San Joaquin Valley Air Pollution Control District (SJVAPCD) Rule 4905 NOx emission limit (14 ng/J) and cannot be installed within the SCAQMD, SJVAPCD and Bay Area
- These furnaces are approved by the California Energy Commission and meets California Nitrogen Oxides Standard (NOx) limits of 40 ng/J

WARRANTY

- Duralok Plus™ Aluminized Steel Heat Exchanger:
 - Limited twenty years in residential applications
 - Limited ten years in non-residential applications
- All other covered components:
 - Limited five years in residential installations
 - Limited one year in non-residential installations

NOTE - Refer to Lennox® Basic Limited Warranty at www.Lennox.com for additional details.

FEATURES

APPLICATIONS

- Input capacities of 44,000, 66,000, 88,000 and 110,000 Btuh
- Energy efficiency (AFUE) - 96%
- Compact cabinet for upflow, horizontal-left or horizontal-right applications without any modifications
- Variable speed blower is ideal for zoning applications
- Removable bottom seal panel shipped in place for side return air is easily removed for bottom/end return air applications
- Utility room, alcove, closet, crawl space, basement or attic installation
- Lennox add-on indoor coils, high-efficiency air cleaners and humidifiers can easily be added to furnace
- Shipped factory assembled with all controls installed and wired
- Each unit factory test operated to ensure proper operation

ZONING APPLICATIONS

- Units may be used with certain zoning systems
- Zone control panel must be able to interface and communicate with the variable speed blower motor in the unit
- Lennox® LZSV Variable Zoning System has this capability

HEATING SYSTEM

- 1 **Lennox Duralok Plus™ Heat Exchanger Assembly**
 - Lennox developed heat exchanger assembly consists of primary heat exchanger and secondary condenser coil assembly
 - Main multi-pass crimped seam design clamshell type
 - Constructed of heavy-gauge, aluminized steel
 - Designed for normal expansion and contraction with maximum efficiency and minimum resistance to air flow
- 2 **Secondary heat exchanger condenser coil constructed of aluminum fins fitted to stainless steel tubes**
 - Coil is factory tested for leaks
 - Condensate drain header box assembly located on front of coil
 - Compact size permits low overall design of furnace cabinet
 - Laboratory life cycle tested in excess of industry standards

FEATURES

HEATING SYSTEM (continued)

Lennox Designed Header Box

- Header box on end of condenser coil collects flue condensate for disposal through condensate drains
- Drains are located on each side of the cabinet for easy field installation of condensate drain trap
- Only one drain is used, the other drain is sealed
- Condensate drain trap is included with the unit for field installation

Lennox Designed Flue Condensate Trap Assembly

- Field installed outside the conditioned air stream
- Assembly can be mounted on either side of cabinet in upflow applications
- Assembly is mounted below the cabinet in horizontal applications
- Assembly can be mounted remotely (up to 5 ft. away) from unit
- See Dimension Drawing and Installation Instructions
- 90° street elbow furnished for ease of drain trap installation
- Drain connection can be made with field provided PVC pipe, PVC coupling, or vinyl tubing with hose clamp
- Drain cap on trap allows easy cleaning and winterizing

3 Inshot Burners

- Aluminized steel inshot burners provide efficient, trouble-free operation
- Burner venturi mixes air and gas in correct proportion for proper combustion
- Burner assembly can be removed from the unit as a single component for ease of service

4 SureLight® Hot Surface Ignitor

- Tough, reliable, long-life, trouble-free performance
- Silicon nitride ignitor
- Cemented to steatite block for protection against current leakage
- Ignition leads are constructed of nickel plated copper and are enclosed in high temperature Teflon® insulation for dependable operation

5 Two-Stage Gas Control Valve

- 24 volt redundant combination two-stage gas control valve combines manual shut off switch (On-Off), automatic electric valve (dual) and gas pressure regulation into a compact combination control

6 Two-Speed Combustion Air Inducer

- Permanent split capacitor (PSC) motor
- Heavy duty blower prepurges heat exchanger and safely vents flue products
- Dual pressure switches (low fire/high fire) prove blower operation before allowing gas valve to open
- Operates only during heating cycle

7 Flame Rollout Switches (2)

- Factory installed on burner box
- Switch provides protection from abnormal operating conditions
- Manual reset

Limit Control

- Primary limit is accurately located on vestibule panel on all units
- Automatic reset

Optional Accessories

High Altitude Orifice Kits

- Required on all units for proper unit operation at altitudes from 7501 to 10,000 ft.
- Kits are available for natural gas and LPG/propane

High Altitude Pressure Switch Kit

- Required for proper unit operation on installations above 4500 ft.

Natural Gas to LPG/Propane Conversion Kit

- Required for field changeover from natural gas to LPG/Propane

LPG/Propane to Natural Gas Conversion Kit

- Required for field changeover from LPG/Propane to natural gas

Muffler (US Only)

- Significantly reduces outdoor operating sound levels
- Two-inch diameter muffler is optional for 070 through 110 input models

NOTE - Two-inch muffler is optional for the 110 input model with a maximum vent pipe length of up to 29 ft.

Three-inch diameter muffler is optional for 110 and 135 input models.

NOTE - Three-inch muffler is optional for the 110 input model with a minimum vent pipe length of 30 ft.

- Installed vertically in the exhaust piping
- See Optional Accessory Dimension Drawing

DIRECT VENT / NON-DIRECT VENT SEALED COMBUSTION SYSTEM

- Furnace features a "sealed combustion" system and can be installed in either Direct Vent or Non-Direct applications
- In Direct Vent applications, combustion air is supplied from outdoors and flue gases are discharged outdoors
- In Non-Direct Vent applications, combustion air is supplied from indoors and flue gases are discharged outdoors

NOTE - Lennox has approved the use of DuraVent® PolyPro®, Centrotherm InnoFlue® and ECCO Polypropylene Vent™ manufactured vent pipe and terminations as an alternative to PVC vent pipe. Must be ordered separately. Tested and listed to the ULC S636 standard in Canada.

- Tested and listed to the ULC S636 standard in Canada

FEATURES

DIRECT VENT / NON-DIRECT VENT SEALED COMBUSTION SYSTEM (continued)

- The polypropylene venting system must follow the uninsulated and unconditioned space vent lengths listed in the table on Page 15
- Refer to the Installation Instructions for additional details

Flue Coupling

- Assists with exhaust flue piping connection and servicing
- Includes flexible one 2 inch rubber coupling and two adjustable bands
- Approved for all Lennox 90% furnaces

Termination Kits

- Facilitates installation of combustion air intake pipe and flue exhaust pipe
- Refer to venting table in this bulletin to determine pipe size needed and proper termination kit required
- Certain Termination Kits are certified to ULC S636 standard for use in Canada only
- See Optional Accessories table and dimension drawings

Concentric - Direct Vent Applications

- 2 or 3 inch kit contains concentric termination assembly, reducer bushing and 45 degree elbow
- 2 inch kit for -045-070 models contains an outdoor exhaust accelerator
- Kit requires single hole penetration of roof or wall for installation
- Roof Termination Flashing Kit is available for use with 2 inch Kits
- CSA certified

Flush-Mount

- Kit contains flush-mount termination, accelerator, mounting template and hardware
- Kit may be used with 2, 2-1/2 or 3 in. pipe

Wall Assembly

Close Couple (US Only) - Direct Vent Applications

- 2 or 3 inch kit consists of close-couple, side-by-side PVC piping with galvanized steel wall cover plate for sealing and isolating piping penetration of the wall
- Piping spacing and length is sized for proper wall installations
- CSA certified

Close Couple WTK (Canada Only) - Direct Vent Applications

- 2 or 3 inch kit contains one insulated faceplate, one insulated exhaust pipe, elbow and fittings. Certified to ULC S636 standard

NOTE - Maintain a maximum of 6 inches between the inlet and outlet openings in the installation of the pipes

Roof Termination Flashing Kit

- For vertical venting through a roof
- 2 or 3 inch kit contains two neoprene rubber roof flashings
- Vent pipe and insulation not furnished

- Flashing Kit can also be used with Concentric Vent Termination Kits used in vertical venting rooftop applications

CONTROLS

8 SureLight® Integrated Two-Stage / Variable Speed Blower Furnace Control

- Advanced control communicates information about various operating parameters in the furnace to the optional Lennox® Communicating Thermostat to constantly maintain the highest level of comfort and performance available
- **Auto Configuration** - On start-up the control automatically sends a description of the unit to the optional Lennox® Communicating Thermostat to automatically configure the number of stages and features available
- Terminals for connecting a conventional heating/cooling thermostat are also provided on the control
- Control also features Innovative AirFlex™ technology which allows custom blower settings based on the application
- **Thermostat Control** - For optimal performance, the use of a high-quality, digital two-stage thermostat with adjustable settings for first stage/second stage, on/off differentials and adjustable stage timers is recommended

Furnace Input Staging Options

Thermostat Type	Input Staging Available
Lennox® Communicating Thermostat	Two-Stage (65 and 100%)
Two-Stage (Conventional)	
Single-Stage (Conventional)	

- **Safety Controls** - Flame sensor utilizes flame rectification for safe and reliable operation
- Should flame fail to ignite, control will initiate 4 re-attempts at ignition before locking out unit operation for 60 minutes
- Watchguard type circuit automatically resets ignition control after one hour of continuous thermostat demand after unit lockout, eliminating nuisance calls for service
- **Display LED** - Seven segment LED displays alpha-numeric information related to diagnostics as well as system operation and status
 - Diagnostic codes are held in non-volatile memory, immune from power interruptions
 - Holds up to ten diagnostic codes in order of occurrence for recall on demand
 - Port on blower door allows for easy viewing

DIP Switch Settings

- **Select Thermostat Used** - Single-Stage or Two-Stage
- Two selectable second stage recognition times (7 and 12 minutes) are available on the control when the furnace is used with a single-stage thermostat

FEATURES

CONTROLS (continued)

- When used with a two-stage thermostat, furnace will only initiate second stage operation with a second stage thermostat demand
 - **Heating Speeds** - A combination of DIP switch settings allow the following motor speed selection settings within the heating speed selected for fine tuning air volume:
 - Factory default
 - 6%, 12%, 18% or 24% increase
 - 6%, 12% or 18% decrease
 - See Blower Performance tables
 - **Cooling Speeds** - A combination of DIP switch settings allow the following motor speed selection settings within the cooling speed selected for fine tuning air volume:
 - Factory default
 - 10% increase
 - 10% decrease
 - See Blower Performance tables
 - **Blower Speed Ramping (Cooling Mode)** - DIP switch settings allow one of four blower speed profiles during cooling operation
 - **Profile A (factory setting)** - Motor runs at 50% for 30 seconds, then at 82% for 7-1/2 minutes, then at 100% (if needed) until demand is satisfied. Once demand is met, motor runs at 50% for 30 seconds, then ramps down to stop
 - **Profile B** - Motor runs at 82% for 7-1/2 minutes and then at 100% (if needed) until demand is satisfied. Once demand is met, motor ramps down to stop
 - **Profile C** - Motor runs at 100% until demand is satisfied. Once demand is met, motor runs at 100% for 60 seconds, then ramps down to stop
 - **Profile D** - Motor runs at 100% until demand is satisfied. Once demand is met, motor ramps down to stop
 - **Dehumidification (Active or Humiditrol® Option)** - A jumper on the control must be clipped to enable active dehumidification and/or operation with a Humiditrol® Whole-Home Dehumidification System
 - A humidity controlling thermostat or device is also required
 - During a call for cooling, air volume is automatically reduced, forcing humidity removal by the air conditioner or heat pump system (single stage units or two-stage units running at 2nd stage)
 - After the humidity has reached the desired set-point the cooling air volume returns to its designed rate
 - A dehumidification signal from the thermostat reduces the cooling cfm to 70% of the requested cooling cfm
 - **Dual-Fuel Operation** - A jumper on the control must be clipped to enable operation with a single or two-stage heat pump
 - The indoor blower is started without delay when a call for heat is received
 - **Two-Stage Compressor Operation** - A jumper on the control must be clipped to enable operation with a two-stage compressor
 - The cooling blower speeds for first and second stage cooling will be dictated by the applicable DIP switch settings
 - **Lennox System Operations Monitor Connection** - Monitors outdoor unit operation (communicating mode)
 - **Blower On/Off Time (Heating)** - Blower on time is fixed at 30 seconds, blower off time is adjustable from 60, 90, 120 and 180 seconds (factory setting - 120 seconds)
 - **Blower On/Off Time (Cooling)** - For air-conditioning applications, blower on time is 2 seconds following thermostat demand for cooling
 - See Blower Speed Ramping (Cooling Mode) profiles for various blower off details
 - Controls evaporator humidity by controlling blower and compressor speed on two-stage outdoor units when used with the Lennox® Communicating Thermostat or the CS7500 Thermostat
 - **Continuous Blower Speed** - Adjustable continuous blower speed is a percentage of the high cooling speed selection
 - Two selectable options (via DIP switch settings) of 28% and 38% (default setting)
 - **Accessory Terminal** - One accessory terminal furnished for additional power supply requirements for 120 volt (less than 1 amp) powered air cleaners
 - One un-powered pair of contacts are provided for humidifier connections and may be connected to 24V or 120V
 - Control is factory installed in the unit control box
- ### **24 Volt Transformer (40VA)**
- Furnished and factory installed on outside of control box
 - Circuit breaker (furnished) is wired in series
- ### **Field Wiring Make-Up Box**
- Furnished for line voltage wiring
 - Factory installed internally on left side of furnace
 - Box may be installed internally on right side of furnace

FEATURES

CONTROLS (continued)

Refrigeration Detection System (RDS)

(Part of the SureLight® Integrated Furnace Control)

- Complies with UL 60335-2-40 approved standard
- Required for all systems using R-454B refrigerant
- Plug-in connection to the RDS Coil Sensor
- Supports up to two RDS Coil Sensors (factory setting)
- Used as an interface between indoor unit and thermostat to control system
- Ensures safe operation for systems equipped with R-454B refrigerant
- If R-454B refrigerant is detected, the refrigerant detection system will stop compressor and/or heating operation and operate the blower to reduce concentrations in the conditioned space
- Once safe levels are reached the HVAC system will resume normal operation
- Low GWP test button for troubleshooting
- Alarm/Zone relay interface can trigger an external alarm if R-454B refrigerant is detected and open all zone dampers (if part of a zoning system) if R-454B refrigerant is detected
- Power is disabled to non-communicating thermostats to prevent demand if R-454B refrigerant is detected
- On system start-up blower will run for five minutes and any thermostat demands are disabled

Optional Accessories

Thermostat

- Thermostat is not furnished with unit
- See Page 10

Transformer (75VA)

- Recommended when furnace is used with zoning or defrost thermostats and other 24V accessories requiring a higher VA rating
- Circuit breaker (furnished) is wired in series
- Replaces the standard 40VA transformer

BLOWER

9 Variable Speed Direct Drive Blower

- Each blower assembly statically and dynamically balanced
- Blower assembly easily removed for servicing

Variable Speed Blower Motor

- Variable speed motor maintains specified air volume from 0 though 0.8 in. w.g. (heating) and 0 through 1.0 in. w.g. (Cooling) static range
- Variable speed operation is achieved by the use of an ECM (Electronically Commutated Motor) motor
- Motor is controlled by furnace control
- Change in blower speed is easily accomplished by simple jumper change on the furnace control
- During start-up the blower motor slowly ramps up to normal operating speed to minimize noise and increase comfort
- At the end of a cooling or heating cycle the motor slowly ramps down after a short blower "off" delay
- If continuous blower operation has been selected, the variable speed motor will slowly ramp down until it reaches the airflow for that condition
- Motor is resiliently mounted
- See Blower Data tables

FEATURES

CABINET

- Low-profile, narrow width allows easy installation
- Heavy-gauge, cold rolled steel construction
- Pre-painted cabinet finish
- Flanges provided on supply air opening for ease of plenum connection or alignment with indoor coil
- 10 • Insulated with foil faced insulation on sides and back of heating compartment
- Sealed blower compartment
- Cabinet door can be removed without any tools
- Complete service access
- 11 • Safety interlock switch automatically shuts off power to unit when blower compartment access door is removed
- 12 • Gas piping and electrical inlets are provided in both sides of cabinet

Bottom/End Return Air Entry:

- Upflow/horizontal applications:
 - Remove furnished bottom seal panel from cabinet
- Side return-air entry (upflow applications only):
 - Corners are marked on either side of cabinet for return air cut-outs
- See dimension drawings

NOTE - 60C size units that require air volumes over 1800 cfm must have one of the following:

- Single side return air and Optional Return Air Base with transition that must accommodate required 20 x 25 x 1 inch air filter to maintain proper velocity
- Bottom return air
- Return air from both sides
- Bottom and one side return air
- See Blower Performance Tables for additional information

Coil Match-Up

- All furnaces exactly match Lennox cased upflow indoor coils and horizontal indoor coils with same letter designation (A, B, C, D) in model number
- No adaptor required
- Engaging holes furnished on cabinet for alignment
- Lennox uncased coils match furnaces without any overhang but require an optional adaptor base or field fabricated transition to match furnace opening
- See coil bulletin for additional information

Low Leakage Cabinet

- All models have less than 2% air leakage
- Meets ANSI/ASHRAE Standard 193-2010 "Method of Test for Determining the Air Tightness of HVAC Equipment"

Optional Accessories

Condensate Drain Heat Cable Kits

- Self-limiting wattage heat cable prevents condensate drain from freezing in unconditioned areas
- Available in 6 or 24 ft. lengths

Horizontal Suspension Kit

- Provides suspension of unit and indoor coil in horizontal applications
- Allows complete service access
- Consists of corner mounted hanging brackets with vibration isolators, return air end support rail and hardware for assembly
- Metal hanging straps must be field provided

Crawl Space Vent Drain Kit

- Allows venting through a crawl space for upflow and horizontal applications
- Kit for Canada is certified to ULC S636
- Includes 2 or 3 inch sanitary tee, 2 inch PVC assembly, PVC boot and clamp

Return Air Base

NOTE - On furnaces with side return air and condensate trap on the same side of the cabinet, a field fabricated transition or Return Air Base is required when using an IAQ product higher than 14-3/16 inches installed next to the unit and serviced from the front. IAQ products higher than 20 inches require a field fabricated transition.

NOTE - Must be used for 60C and 60D size models with air volumes over 1800 cfm in upflow applications when only one side return is required.

- Cabinet is shipped flat for easy field assembly
- Pre-painted steel to match the furnace
- See Dimension Drawing

Optional Accessories (continued)

High Performance Economizer (Commercial Applications Only)

- Designed for applications requiring outdoor air to be utilized in a commercial HVAC system. Allows the entry of fresh outdoor air for free cooling, reducing the requirement for mechanical cooling
- Heavy gauge galvanized steel cabinet lined with thick fiberglass insulation. Mixed air sensor, outdoor air sensor and 24VAC transformer furnished.
- Approved for California Title 24 building standards. ASHRAE 90.1-2010 compliant
- See separate Product Specifications bulletin for additional information and available control and sensor options

FEATURES

FILTER (not furnished)

- Filter and provisions for external mounting must be field provided

Optional Accessories

Air Filter and Rack Kit for Horizontal Return Air (End)

Applications

- Washable or vacuum cleanable polyurethane frame type filter and external end return air rack
- Rack has filter door for servicing
- Flanges on rack for duct connection
- Field installed
- See dimension drawing

Air Filter and Rack Kit for Upflow Side Return Air

NOTE - Not for use with Return Air Base

- Washable or vacuum cleanable polyurethane frame type filter and external side return air rack available for field installation
- Available in single and ten pack kits
- Rack has filter door for servicing
- Flanges on rack for duct connection
- Field installs on either side of unit cabinet
- See dimension drawing

INDOOR AIR QUALITY PRODUCT OPTIONS

Healthy Climate® PureAir® Air Purification System

- Filtration - The Carbon Clean 16® (MERV 16) media filter captures more than 95% of particles 0.3 microns and larger and more than 90% of particles 0.01 microns and larger
- Highest airflow performance and lowest pressure drop when compared to a leading brand.
- Long life filters up to 1 year



Healthy Climate® Media Air Cleaner

- High performance in a narrow 7 in. cabinet
- Available with MERV 11, 13, or 16 rated filters
- Multi-position heavy gauge steel cabinet will support furnace/coil or air handler and associated duct work
- Tool-less entry
- Tool-less assembly for quick installation



Healthy Climate® Whole Home In Duct Air Purifiers

- Compact Duct Mounted Design
- Effective against odors and VOC's
- Certified Ozone free
- UVC lamp and carbon cells



Healthy Climate® Ultraviolet Germicidal Lights

- Compact duct mounted design
- Single or dual applications
- Certified ozone free
- Effective against odors to help keep the system clean
- Safety Interlocks (Additional UVC Compliance Kit for UL 60335-2-40 is available for A2L applications)
- Low power consumption
- Available for 24V or 110/230V
- Up to 1340 microwatts /cm² output (dual lamp model)



NOTE - Please refer to the individual Product Specifications for these products for full information.

CONTROL OPTIONS

E40 Smart Wi-Fi Thermostat

- 3 Htg.-2 Clg.
- 7-day, universal, programmable, touchscreen thermostat
- Controls dehumidification during cooling mode and humidification during heating mode
- Smooth Setback Recovery and compressor short-cycle protection
- One-Touch Away Mode, Smart Away™ (geo-fencing), equipment maintenance reminders and scheduling
- Smart home automation compatible with Apple HomeKit™, Amazon Alexa® and Google Assistant
- Lennox® Home App controls temperature, fan operation, set programs/schedules and set Away mode on a smartphone
- Lennox Smart Tech App allows the installer to commission the system and remotely turn the system on and off during setup or service call on a smartphone



M40 Smart Wi-Fi Thermostat

- 3 Htg.-2 Clg.
- 7-day, universal, programmable, touchscreen thermostat
- Smooth Setback Recovery and compressor short-cycle protection
- One-Touch Away Mode, Smart Away™ (geo-fencing), equipment maintenance reminders and scheduling
- Smart home automation compatible with Apple HomeKit™, Amazon Alexa®, Google Assistant and Matter
- Lennox® Home App controls temperature, fan operation, set programs/schedules and set Away mode on a smartphone
- Lennox Smart Tech App allows the installer to commission the system and remotely turn the system on and off during setup or service call on a smartphone



NOTE - Please refer to the individual Product Specifications for these products for full information.

INDOOR AIR QUALITY PRODUCT OPTIONS - ORDERING

NOTE - Refer to the individual Product Specifications documents for additional accessories and maintenance items.

Description	Dimensions	Furnace Width	Order Number
PureAir® S Air Purification System			
PCO3S-16-16	17-1/2 x 8-3/4 x 26-1/2	A/B/C	Y8904
PCO3S-20-16	21-1/8 x 8-3/4 x 26-1/2	C/D	Y8903
Healthy Climate® Media Air Cleaner			
HCC16-28 (Cabinet)	17-1/2 x 28-1/2 x 7	A/B/C	Y2920
HCC16-28 (Cabinet) 4-pack	17-1/2 x 28-1/2 x 7	---	Y2921
HCF16-16 (Filter) MERV 16	16 x 25 x 5	---	X6672
HCXF16-16 (Expandable Filter) MERV 16	16 x 25 x 5	---	X8306
HCF16-13 MERV 13	16 x 25 x 5	---	19L16
HCF16-11 (Filter) MERV 11	16 x 25 x 5	---	X6670
HCXF16-11 (Expandable Filter) MERV 11	16 x 25 x 5	---	X8303
HCC20-28 (Cabinet)	21 x 28-1/2 x 7	C/D	X6661
HCC20-28 (Cabinet) 4-pack	21 x 28-1/2 x 7	---	X7751
HCF20-16 (Filter) MERV 16	20 x 25 x 5	---	X6675
HCXF20-16 (Expandable Filter) MERV 16	20 x 25 x 5	---	X8307
HCF20-13 MERV 13	20 x 25 x 5	---	19L17
HCF20-11 (Filter) MERV 11	20 x 25 x 5	---	X6673
HCXF20-11 (Expandable Filter) MERV 11	20 x 25 x 5	---	X8304
Healthy Climate® Whole Home In Duct Air Purifiers			
HCWHAP1	8 x 7 x 16.5	---	23V99
Healthy Climate® Ultraviolet Germicidal Lights			
UVC-24V (24V) 17-1/2 in.	Ballast 4-3/4 x 2-1/4 x 2	---	X9423
UVC-41W-S (110/230V) 17-1/2 in.	Ballast 11-3/4 x 2-3/4 x 1-5/8	---	X9424
UVC-41W-D (110/230V) 17-1/2 in.	Ballast 11-3/4 x 2-3/4 x 1-5/8	---	X9425
CONTROLS - ORDERING			
E40 Smart Wi-Fi Thermostat	3-3/8 x 5-3/8 x 1	---	30L26
Lennox® Smart Room Sensor	4 x 5-1/2 x 3	---	22V25
Lennox® Smart Air Quality Monitor	3-5/8 x 4-3/8 x 1-3/8	---	21P02
Lennox® Wireless Extender	4 x 5-1/2 x 2-1/2	---	22V26
M40 Smart Wi-Fi Thermostat	3-5/16 x 4-5/16 x 7/8	---	30L27
Thermostat Accessories			
¹ Discharge Air Temperature Sensor (For S40, E40)			88K38
² Remote Outdoor Air Temperature Sensor (For dual-fuel and Humiditrol®)			X2658

¹ Optional for service diagnostics (E40).

² Remote Outdoor Air Temperature Sensor is used with conventional (non-Lennox® Communicating) outdoor units (sensor is furnished with Lennox® Communicating outdoor units). Allows the thermostat to display outdoor temperature. Required in dual-fuel and Humiditrol® applications.

SPECIFICATIONS

Gas Heating Performance	Model	ML296UH045XV36BK	ML296UH070XV36BK
	¹ AFUE	96%	96%
High Fire	Input - Btuh	44,000	66,000
	Output - Btuh	42,000	62,000
	Temperature rise range - °F	35 - 65	50 - 80
	Gas Manifold Pressure (in. w.g.) Nat. Gas / LPG/Propane	3.5 / 10.0	3.5 / 10.0
Low Fire	Input - Btuh	29,000	43,000
	Output - Btuh	28,000	41,000
	Temperature rise range - °F	20 - 50	25 - 55
	Gas Manifold Pressure (in. w.g.) Nat. Gas / LPG/Propane	1.7 / 4.5	1.7 / 4.5
High static - in. w.g.	Heating	0.8	0.8
	Cooling	1.0	1.0
Connections	Intake / Exhaust Pipe (PVC)	2 / 2	2 / 2
	Gas pipe size IPS	1/2	1/2
	Condensate Drain Trap (PVC pipe) - i.d. with furnished 90° street elbow	3/4	3/4
	with field supplied (PVC coupling) - o.d.	3/4 slip x 3/4 MIPT 3/4 slip x 3/4 MPT	3/4 slip x 3/4 MIPT 3/4 slip x 3/4 MPT
Indoor Blower	Wheel diameter x width - in.	10 x 9	10 x 9
	Motor output - hp	1/2	1/2
	Tons of add-on cooling	2 - 3	2 - 3
	Air Volume Range - cfm	485 - 1370	500 - 1365
Electrical Data	Voltage	120 volts - 60 hertz - 1 phase	
	Blower motor full load amps	7.7	7.7
	Maximum overcurrent protection	15	15
Shipping Data	lbs. - 1 package	130	138

NOTE - Filters and provisions for mounting are not furnished and must be field provided.

¹ Annual Fuel Utilization Efficiency based on DOE test procedures and according to FTC labeling regulations. Isolated combustion system rating for non-weatherized furnaces.

SPECIFICATIONS

Gas Heating Performance	Model	ML296UH090XV48CK	ML296UH110XV60CK
	¹ AFUE	96%	96%
High Fire	Input - Btuh	88,000	110,000
	Output - Btuh	85,000	106,000
	Temperature rise range - °F	45 - 75	45 - 75
	Gas Manifold Pressure (in. w.g.) Nat. Gas / LPG/Propane	3.5 / 10.0	3.5 / 10.0
Low Fire	Input - Btuh	57,000	72,000
	Output - Btuh	55,000	70,000
	Temperature rise range - °F	30 - 60	35 - 65
	Gas Manifold Pressure (in. w.g.) Nat. Gas / LPG/Propane	1.7 / 4.5	1.7 / 4.5
High static - in. w.g.	Heating	0.8	0.8
	Cooling	1.0	1.0
Connections	Intake / Exhaust Pipe (PVC)	2 / 2	2 / 2
	Gas pipe size IPS	1/2	1/2
	Condensate Drain Trap (PVC pipe) - i.d. with furnished 90° street elbow	3/4	3/4
	with field supplied (PVC coupling) - o.d.	3/4 slip x 3/4 MIPT 3/4 slip x 3/4 MPT	3/4 slip x 3/4 MIPT 3/4 slip x 3/4 MPT
Indoor Blower	Wheel diameter x width - in.	11 x 11	11 x 11
	Motor output - hp	3/4	1
	Tons of add-on cooling	2.5 - 4	3 - 5
	Air Volume Range - cfm	680 - 1770	790 - 1955
Electrical Data	Voltage	120 volts - 60 hertz - 1 phase	
	Blower motor full load amps	9.6	12.8
	Maximum overcurrent protection	15	20
Shipping Data	lbs. - 1 package	163	174

NOTE - Filters and provisions for mounting are not furnished and must be field provided.

¹ Annual Fuel Utilization Efficiency based on DOE test procedures and according to FTC labeling regulations. Isolated combustion system rating for non-weatherized furnaces.

OPTIONAL ACCESSORIES

NOTE - FURNACES CANNOT BE TWINNED!

		"B" Width Models	"C" Width Models	
CABINET ACCESSORIES				
Horizontal Suspension Kit - Horizontal only		51W10	51W10	
Return Air Base - Upflow only		50W98	50W99	
High Performance Economizer (Commercial Only)		10U53	10U53	
CONDENSATE DRAIN KITS				
Condensate Drain Heat Cable	6 ft.	26K68	26K68	
	24 ft.	26K69	26K69	
Crawl Space Vent Drain Kit	US	51W18	51W18	
	Canada	15Z70	15Z70	
CONTROLS				
Transformer (75VA)		27J32	27J32	
FILTER KITS				
¹ Air Filter and Rack Kit	Horizontal (end)	87L96	87L97	
	Side Return	Size of filter - in.	18 x 25 x 1	20 x 25 x 1
		Single	44J22	44J22
	Ten Pack	66K63	66K63	
Size of filter - in.	16 x 25 x 1	16 x 25 x 1		
TERMINATION KITS				
See Installation Instructions for specific venting information.				
Direct Vent	Concentric	US - 2 in.	71M80	69M29
		3 in.	- - -	60L46
		Canada - 2 in.	44W92	44W92
		3 in.	- - -	44W93
	Flush-Mount	US - 2, 2-1/2 or 3 in.	51W11	51W11
		Canada - 2, 2-1/2 or 3 in.	51W12	51W12
	Wall - Close Couple	US - 2 in.	22G44	- - -
		3 in.	44J40	44J40
	Wall - Close Couple WTK	Canada - 2 in.	30G28	- - -
		3 in.	81J20	81J20
	Roof Termination Flashing Kit (no vent pipe - 2 flashings)	2 in.	15F75	15F75
		3 in.	44J41	44J41
VENTING				
Flue Coupling	2 in.	17H92	17H92	

¹ Allows the thermostat to display outdoor temperature. Required in dual-fuel and EDA applications.

NOTE - Termination Kits (44W92, 44W93, 30G28, 51W12, 81J20) and Crawl Space Vent Drain Kit (15Z70) are certified to ULC S636 standard for use in Canada only.

INSTALLATION CLEARANCES

Sides	¹ 0 inches (0 mm)
Rear	0 inches (0 mm)
Top/Plenum	1 inch (25 mm)
Front	0 inches (0 mm)
Front (service/alcove)	24 inches (610 mm)
Floor	² Combustible

NOTE - Air for combustion must conform to the methods outlined in the National Fuel Gas Code (NFPA 54/ANSI-Z223.1) or the National Standard of Canada CAN/CSA-B149.1 Natural Gas and Propane Installation Code".

NOTE - In the U.S. flue sizing must conform to the methods outlined in the current National Fuel Gas Code (NFPA 54/ANSI-Z223.1) or applicable provisions of local building codes. In Canada flue sizing must conform to the methods outlined in National Standard of Canada CAN/CSA-B149.1.

¹ Allow proper clearances to accommodate condensate trap and vent pipe installation.

² Do not install the furnace directly on carpeting, tile, or other combustible materials other than wood flooring.

GAS HEAT ACCESSORIES

Input	High Altitude Pressure Switch Kit		Natural Gas to LPG/Propane Kit	LPG/Propane to Natural Gas Kit	Natural Gas High Altitude Orifice Kit	LPG/Propane High Altitude Orifice Kit	Muffler (US Only)
	4501 - 7500 ft.	7501 - 10,000 ft.	0 - 7500 ft.	0 - 7500 ft.	7501 - 10,000 ft.	7501 - 10,000 ft.	
045	14A47	14A50	11K51	77W09	73W37	11K46	15Y66 (2-inch)
070	14A54	14A53	11K51	77W09	73W37	11K46	15Y66 (2-inch)
090	14A57	14A54	11K51	77W09	73W37	11K46	15Y66 (2-inch)
110	14A46	14A51	11K51	77W09	73W37	11K46	¹ 15Y66 (2-inch) 16A56 (3-inch)

¹ Two-inch diameter muffler (15Y66) is optional for 110 input model with a maximum vent pipe length of up to 29 ft.
Three-inch diameter muffler (16A56) is optional for 110 input model with a minimum vent pipe length of 30 ft.

HIGH ALTITUDE DERATE

NOTE - Units may be installed at altitudes up to 10,000 ft.

At altitudes above 4501 ft. the unit must be derated to match the manifold pressure information shown below.

Units installed at altitudes of 4501 to 10,000 ft. require a pressure switch change.

Units installed at altitudes of 7501 to 10,000 ft. require an orifice change.

See the Gas Heat Accessories table for ordering information.

NOTE - This is the only permissible derate for these units.

NOTE - In Canada, certification for installations at elevations over 4500 feet is the jurisdiction of local authorities.

Input	Gas	Manifold Pressure in. w.g.										Supply Line Pressure in. w.g. 0 - 10,000 ft.	
		0 - 4500 ft.		4501 - 5500 ft.		5501 - 6500 ft.		6501 - 7500 ft.		7501 - 10,000 ft.			
		Low Fire	High Fire	Low Fire	High Fire	Low Fire	High Fire	Low Fire	High Fire	Low Fire	High Fire	Min.	Max.
All Sizes	Natural	1.7	3.5	1.6	3.3	1.5	3.2	1.5	3.1	1.7	3.5	4.5	13.0
	LPG/Propane	4.5	10.0	4.2	9.4	4.0	9.1	3.9	8.9	4.5	10.0	11.0	13.0

OUTDOOR TERMINATION KIT USAGE

Input Size	Vent Pipe Diameter (in.)	Standard Terminations				Concentric Terminations		
		Flush Mount Kit	Wall Kit		Field Fabricated Exhaust Accelerator Size Required	Concentric Kit		
			2 inch	3 inch		1-1/2 inch	2 inch	3 inch
			⁵ 51W11 (US) ⁵ 51W12 (CA)	⁵ 22G44 (US) ⁵ 30G28 (CA)		⁵ 44J40 (US) ⁵ 81J20 (CA)	⁵ 71M80 (US) ⁵ 44W92 (CA)	⁵ 69M29 (US) ⁵ 44W92 (CA)
045	¹ 1-1/2	⁴ YES	YES	² YES	1-1/2 in.	³ YES	---	---
	2	⁴ YES	YES	² YES	1-1/2 in.	³ YES	---	---
	2-1/2	⁴ YES	YES	² YES	1-1/2 in.	³ YES	---	---
	3	⁴ YES	YES	² YES	1-1/2 in.	³ YES	---	---
070	¹ 1-1/2	⁴ YES	YES	² YES	1-1/2 in.	³ YES	---	---
	2	⁴ YES	YES	² YES	1-1/2 in.	³ YES	---	---
	2-1/2	⁴ YES	YES	² YES	1-1/2 in.	³ YES	---	---
	3	⁴ YES	YES	² YES	1-1/2 in.	³ YES	---	---
090	2	⁴ YES	---	YES	2 in.	---	YES	YES
	2-1/2	⁴ YES	---	YES	2 in.	---	YES	YES
	3	⁴ YES	---	YES	2 in.	---	YES	YES
110	2	YES	---	YES	2 in.	---	YES	YES
	2-1/2	YES	---	YES	2 in.	---	YES	YES
	3	YES	---	YES	2 in.	---	YES	YES

NOTE - Standard Terminations do not include any vent pipe or elbows external to the structure.

Any vent pipe or elbows external to the structure must be included in total vent length calculations. See Vent Length Tables.

¹ 2 in. to 1-1/2 in. reducer required, must be field provided.

² Requires field provided 1-1/2 in. outdoor exhaust accelerator.

³ Concentric Kits **71M80** and **44W92** include 1-1/2 in. outdoor exhaust accelerator, required when used with 045 and 070 input models. Accelerator is not used with 090, 110, 135 input models. When using 1-1/2 in. piping, the pipe must be transitioned to 2 in. pipe when used with the Concentric Kit.

⁴ Flush Mount Kit **51W11** and **51W12** includes 1-1/2 in. outdoor exhaust accelerator, required when used with 045, 070 and 090 input models. Accelerator is not used with 110 or 135 input models. When using 1-1/2 in. piping, the pipe must be transitioned to 2 in. pipe when used with the Flush Mount Kit.

⁵ Termination Kits **30G28**, **44W92**, **44W93**, **51W12** and **81J20** are certified to ULC S636 standard for use in Canada only.

VENT LENGTHS - UNINSULATED EXHAUST PIPE IN UNCONDITIONED SPACE

¹ Winter Design Temperatures	Vent Pipe Diameter	Unit Input Size							
		045		070		090		110	
		² Maximum Uninsulated Exhaust Vent Length (ft.)							
		PVC	³ PolyPro/ InnoFlue/ ECCO	PVC	³ PolyPro/ InnoFlue/ ECCO	PVC	³ PolyPro/ InnoFlue/ ECCO	PVC	³ PolyPro/ InnoFlue/ ECCO
32 to 21°F	1-1/2 in.	22	N/A	25	N/A	N/A	N/A	N/A	N/A
	2 in.	21	18	33	30	46	42	30	30
	2-1/2 in.	16	N/A	26	N/A	37	N/A	36	N/A
	3 in.	12	12	21	21	30	30	29	29
20 to 1°F	1-1/2 in.	12	N/A	20	N/A	N/A	N/A	N/A	N/A
	2 in.	11	9	19	17	28	25	27	24
	2-1/2 in.	7	N/A	14	N/A	21	N/A	20	N/A
	3 in.	N/A	N/A	9	9	16	16	14	14
0 to -20°F	1-1/2 in.	8	N/A	13	N/A	N/A	N/A	N/A	N/A
	2 in.	6	4	12	10	19	16	18	15
	2-1/2 in.	N/A	N/A	7	N/A	13	N/A	12	N/A
	3 in.	N/A	N/A	N/A	N/A	8	8	7	7

¹ Refer to 99% Minimum Design Temperature table provided in the current edition of the ASHRAE Handbook-Fundamentals.

² Maximum Equivalent Vent Length permitted is defined as Total Length (linear feet) of vent pipe, plus equivalent length (ft.) of fittings, plus equivalent length (ft.) of termination.

VENTING NOTES - Concentric Terminations are equivalent to 5 ft. of straight pipe and should be included when measuring total pipe length.

One 90° elbow is equivalent to 5 feet of straight vent pipe.

Two 45° elbows are equal to one 90° elbow.

One 45° elbow is equivalent to 2.5 feet of straight vent pipe.

³ PolyPro® poly-propylene vent pipe is a registered trademark of DuraVent®.

InnoFlue® is a registered trademark of Centrotherm Eco Systems.

ECCO Polypropylene Vent™ is a registered trademark of ECCO Manufacturing™.

VENT LENGTHS - FEET

STANDARD TERMINATION AT ELEVATION 0 - 4500 ft.

Pipe Size	1-1/2 in.				2 in.				2-1/2 in.				3 in.				
	Input	045	070	090	110	045	070	090	110	045	070	090	110	045	070	090	110
No. of 90 ELL	1	25	20	N/A	N/A	81	66	44	24	115	115	93	58	138	137	118	118
	2	20	15	N/A	N/A	76	61	39	19	110	110	88	53	133	132	113	113
	3	15	10	N/A	N/A	71	56	34	14	105	105	83	48	128	127	108	108
	4	10	N/A	N/A	N/A	66	51	29	N/A	100	100	78	43	123	122	103	103
	5	N/A	N/A	N/A	N/A	61	46	24	N/A	95	95	73	38	118	117	98	98
	6	N/A	N/A	N/A	N/A	56	41	19	N/A	90	90	68	33	113	112	93	93
	7	N/A	N/A	N/A	N/A	51	36	14	N/A	85	85	63	28	108	107	88	88
	8	N/A	N/A	N/A	N/A	46	31	N/A	N/A	80	80	58	23	103	102	83	83
	9	N/A	N/A	N/A	N/A	41	26	N/A	N/A	75	75	53	18	98	97	78	78
	10	N/A	N/A	N/A	N/A	36	21	N/A	N/A	70	70	48	13	93	92	73	73

STANDARD TERMINATION ELEVATION 4501 - 10,000 ft.

Pipe Size	1-1/2 in.				2 in.				2-1/2 in.				3 in.				
	Input	045	070	090	110	045	070	090	110	045	070	090	110	045	070	090	110
No. of 90 ELL	1	25	20	N/A	N/A	81	66	44	N/A	115	115	93	58	138	137	118	118
	2	20	15	N/A	N/A	76	61	39	N/A	110	110	88	53	133	132	113	113
	3	15	10	N/A	N/A	71	56	34	N/A	105	105	83	48	128	127	108	108
	4	10	N/A	N/A	N/A	66	51	29	N/A	100	100	78	43	123	122	103	103
	5	N/A	N/A	N/A	N/A	61	46	24	N/A	95	95	73	38	118	117	98	98
	6	N/A	N/A	N/A	N/A	56	41	19	N/A	90	90	68	33	113	112	93	93
	7	N/A	N/A	N/A	N/A	51	36	14	N/A	85	85	63	28	108	107	88	88
	8	N/A	N/A	N/A	N/A	46	31	N/A	N/A	80	80	58	23	103	102	83	83
	9	N/A	N/A	N/A	N/A	41	26	N/A	N/A	75	75	53	18	98	97	78	78
	10	N/A	N/A	N/A	N/A	36	21	N/A	N/A	70	70	48	13	93	92	73	73

CONCENTRIC TERMINATION AT ELEVATION 0 - 4500 ft.

Pipe Size	1-1/2 in.				2 in.				2-1/2 in.				3 in.				
	Input	045	070	090	110	045	070	090	110	045	070	090	110	045	070	090	110
No. of 90 ELL	1	20	15	N/A	N/A	73	58	42	22	105	105	89	54	121	121	114	114
	2	15	10	N/A	N/A	68	53	37	17	100	100	84	49	116	116	109	109
	3	10	N/A	N/A	N/A	63	48	32	12	95	95	79	44	111	111	104	104
	4	N/A	N/A	N/A	N/A	58	43	27	N/A	90	90	74	39	106	106	99	99
	5	N/A	N/A	N/A	N/A	53	38	22	N/A	85	85	69	34	101	101	94	94
	6	N/A	N/A	N/A	N/A	48	33	17	N/A	80	80	64	29	96	96	89	89
	7	N/A	N/A	N/A	N/A	43	28	12	N/A	75	75	59	24	91	91	84	84
	8	N/A	N/A	N/A	N/A	38	23	N/A	N/A	70	70	54	19	86	86	79	79
	9	N/A	N/A	N/A	N/A	33	18	N/A	N/A	65	65	49	14	81	81	74	74
	10	N/A	N/A	N/A	N/A	28	13	N/A	N/A	60	60	44	N/A	76	76	69	69

CONCENTRIC TERMINATION ELEVATION 4501 - 10,000 ft.

Pipe Size	1-1/2 in.				2 in.				2-1/2 in.				3 in.				
	Input	045	070	090	110	045	070	090	110	045	070	090	110	045	070	090	110
No. of 90 ELL	1	20	15	N/A	N/A	73	58	42	N/A	105	105	89	54	121	121	114	114
	2	15	10	N/A	N/A	68	53	37	N/A	100	100	84	49	116	116	109	109
	3	10	N/A	N/A	N/A	63	48	32	N/A	95	95	79	44	111	111	104	104
	4	N/A	N/A	N/A	N/A	58	43	27	N/A	90	90	74	39	106	106	99	99
	5	N/A	N/A	N/A	N/A	53	38	22	N/A	85	85	69	34	101	101	94	94
	6	N/A	N/A	N/A	N/A	48	33	17	N/A	80	80	64	29	96	96	89	89
	7	N/A	N/A	N/A	N/A	43	28	12	N/A	75	75	59	24	91	91	84	84
	8	N/A	N/A	N/A	N/A	38	23	N/A	N/A	70	70	54	19	86	86	79	79
	9	N/A	N/A	N/A	N/A	33	18	N/A	N/A	65	65	49	14	81	81	74	74
	10	N/A	N/A	N/A	N/A	28	13	N/A	N/A	60	60	44	N/A	76	76	69	69

VENT LENGTHS (EXHAUST) - VENTILATED ATTIC OR CRAWLSPACE INTAKE AIR - FEET

STANDARD TERMINATION AT ELEVATION 0 - 4500 ft.

Pipe Size		1-1/2 in.				2 in.				2-1/2 in.				3 in.			
Input		045	070	090	110	045	070	090	110	045	070	090	110	045	070	090	110
No. of 90 ELL	1	20	15	N/A	N/A	71	56	34	14	100	100	78	43	118	117	98	98
	2	15	10	N/A	N/A	66	51	29	9	95	95	73	38	113	112	93	93
	3	10	N/A	N/A	N/A	61	46	24	4	90	90	68	33	108	107	88	88
	4	N/A	N/A	N/A	N/A	56	41	19	N/A	85	85	63	28	103	102	83	83
	5	N/A	N/A	N/A	N/A	51	36	14	N/A	80	80	58	23	98	97	78	78
	6	N/A	N/A	N/A	N/A	46	31	9	N/A	85	75	63	18	93	92	73	73
	7	N/A	N/A	N/A	N/A	41	26	4	N/A	70	70	48	13	88	87	68	68
	8	N/A	N/A	N/A	N/A	36	21	N/A	N/A	65	65	43	8	83	82	63	63
	9	N/A	N/A	N/A	N/A	31	16	N/A	N/A	60	60	38	3	78	77	58	58
	10	N/A	N/A	N/A	N/A	26	11	N/A	N/A	55	55	33	N/A	73	72	53	53

STANDARD TERMINATION ELEVATION 4501 - 10,000 ft.

Pipe Size		1-1/2 in.				2 in.				2-1/2 in.				3 in.			
Input		045	070	090	110	045	070	090	110	045	070	090	110	045	070	090	110
No. of 90 ELL	1	20	15	N/A	N/A	71	56	34	N/A	100	100	78	43	118	117	98	98
	2	15	10	N/A	N/A	66	51	29	N/A	95	95	73	38	113	112	93	93
	3	10	N/A	N/A	N/A	61	46	24	N/A	90	90	68	33	118	107	88	88
	4	N/A	N/A	N/A	N/A	56	41	19	N/A	85	85	63	28	113	102	83	83
	5	N/A	N/A	N/A	N/A	51	36	14	N/A	80	80	58	23	98	97	78	78
	6	N/A	N/A	N/A	N/A	46	31	9	N/A	85	85	53	18	93	92	73	73
	7	N/A	N/A	N/A	N/A	41	26	4	N/A	70	70	48	13	98	87	68	68
	8	N/A	N/A	N/A	N/A	36	21	N/A	N/A	65	65	43	8	93	82	63	63
	9	N/A	N/A	N/A	N/A	31	16	N/A	N/A	60	60	38	3	78	77	58	58
	10	N/A	N/A	N/A	N/A	26	11	N/A	N/A	55	55	33	N/A	73	72	53	53

DIMENSIONS - UNIT - HORIZONTAL POSITION

LEFT-HAND AIR DISCHARGE

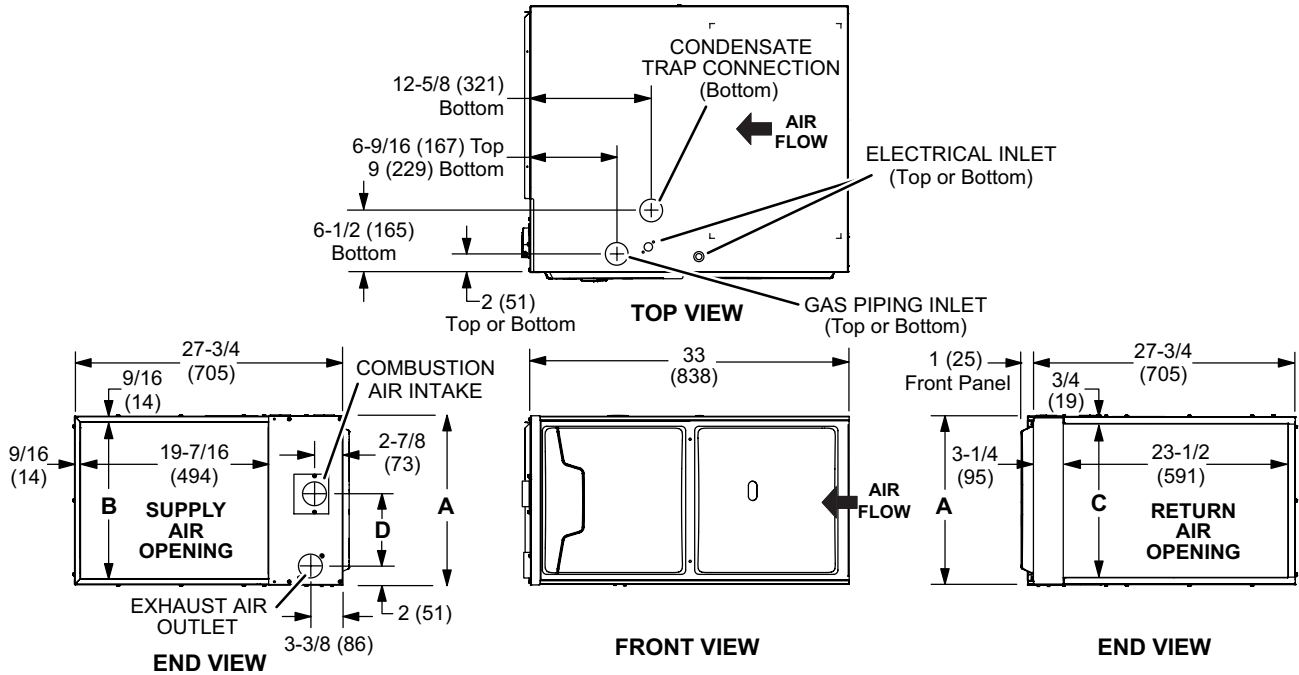

RIGHT-HAND AIR DISCHARGE

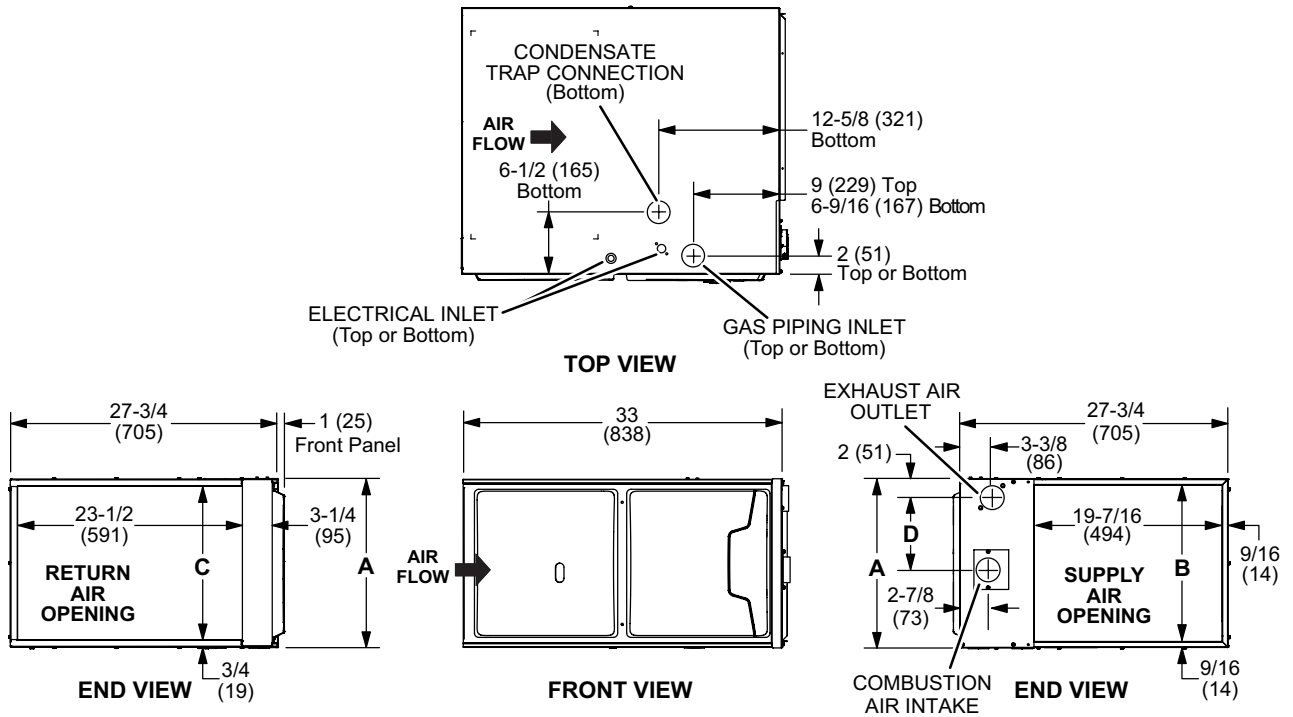

Model No.	A		B		C		D	
	in.	mm	in.	mm	in.	mm	in.	mm
ML296UH045XV36BK ML296UH070XV36BK	17-1/2	446	16-3/8	416	16	406	7-5/8	194
ML296UH090XV48CK ML296UH110XV60CK	21	533	19-7/8	505	19-1/2	495	9-3/8	238

DIMENSIONS - OPTIONAL ACCESSORIES

HORIZONTAL (END) FILTER KIT

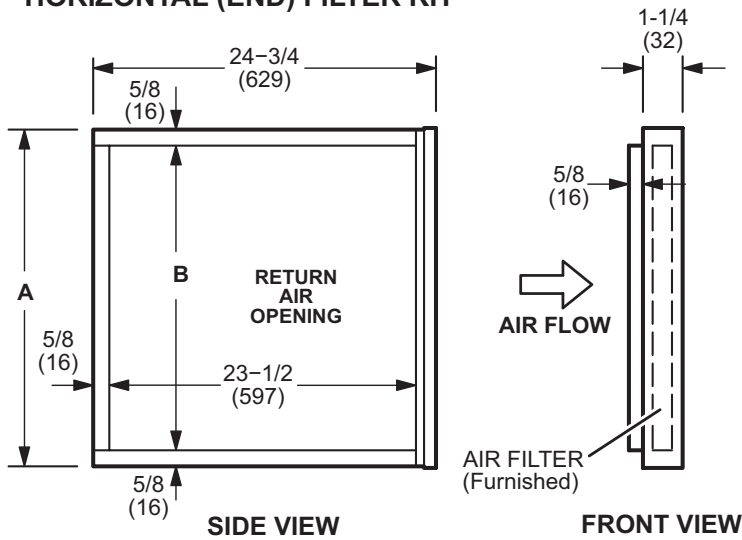

Furnace Cabinet Width	Catalog Number	A		B	
		in.	mm	in.	mm
B	87L96	18	457	16-3/4	425
C	87L97	21	533	18-3/4	476

OPTIONAL RETURN AIR BASE (Upflow Applications Only - For use with B and C width cabinets)

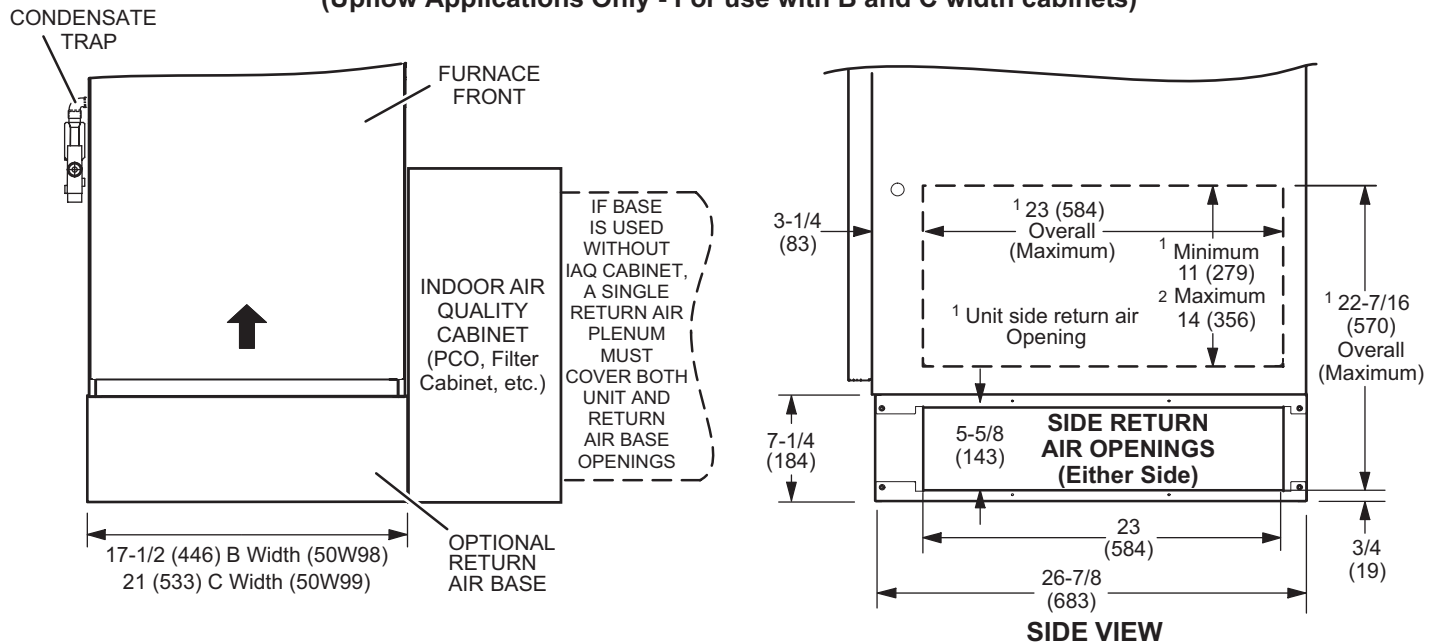

NOTE- Optional Side Return Air Filter Kits are not for use with Optional Return Air Base.

- ¹ Both the unit return air opening and the base return air opening must be covered by a single plenum or IAQ cabinet. Minimum unit side return air opening dimensions for units requiring 1800 cfm or more of air (W x H): 23 x 11 in. (584 x 279 mm). The opening can be cut as needed to accommodate plenum or IAQ cabinet while maintaining dimensions shown. Side return air openings must be cut in the field. There are cutting guides stenciled on the cabinet for the side return air opening. The size of the opening must not extend beyond the markings on the furnace cabinet.
- ² To minimize pressure drop, the largest opening height possible, up to 14 in. (356 mm), is preferred.

DIMENSIONS - FURNACE/COIL COMBINED DIMENSIONS

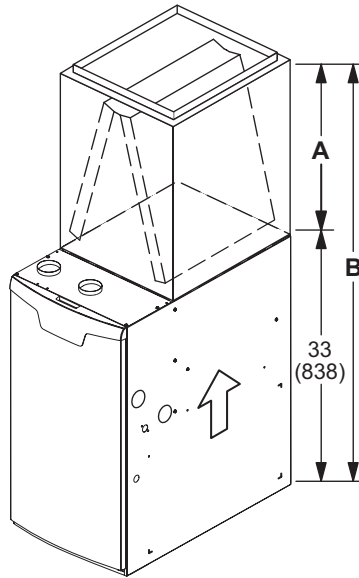

UPFLOW POSITION - CASED

Model	A		B	
	in.	mm	in.	mm
CK40CT				
CK40CT-18/24B	16-1/2	419	49-1/2	1257
CK40CT-24B	18-1/2	470	51-1/2	1308
CK40CT-30B	22-1/2	572	55-1/2	1410
CK40CT-30/36B CK40CT-30/36C	24-1/2	622	57-1/2	1461
CK40CT-36B CK40CT-36C	24-1/2	622	57-1/2	1461
CK40CT-48B CK40CT-48C	27-1/2	699	60-1/2	1537
CK40CT-49C	29-1/2	749	62-1/2	1588
CK40CT-50/60C	27-1/2	699	60-1/2	1537
CK40CT-60C	31-1/2	800	64-1/2	1638

UPFLOW POSITION - UNCASD

Model	A		B	
	in.	mm	in.	mm
CK40UT				
CK40UT-18/24B	14-1/8	359	47-1/8	1197
CK40UT-24B	16-3/8	416	49-3/8	1254
CK40UT-30B	20-3/4	527	53-3/4	1365
CK40UT-30/36B CK40UT-30/36C CK40UT-36C	22-1/4	565	55-1/4	1403
CK40UT-36B	22-3/8	568	55-3/8	1407
CK40UT-48B CK40UT-48C	26-1/4	667	59-1/4	1505
CK40UT-49C	28-1/2	724	61-1/2	1562
CK40UT-50/60C	25-7/8	657	58-7/8	1495
CK40UT-60C	30-5/8	778	63-5/8	1616

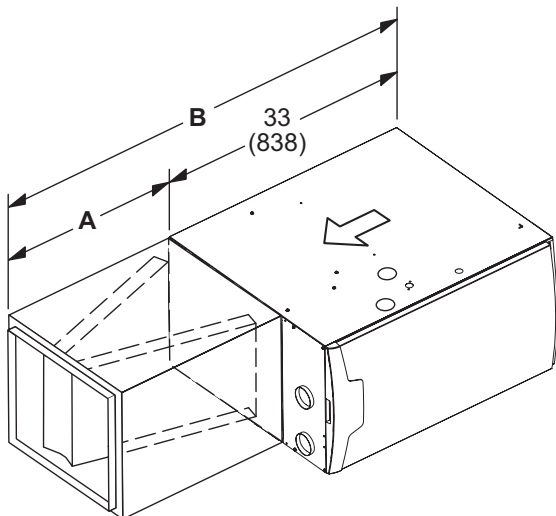

HORIZONTAL POSITION

Model	A		B	
	in.	mm	in.	mm
CK40HT				
CK40HT-24B CK40HT-30B CK40HT-36B CK40HT-36C CK40HT-42C CK40HT-48C	26-1/2	673	59-1/2	1511
CK40CT-42B CK40CT-48B CK40CT-51/61C	31-1/2	880	64-1/2	1638

DIMENSIONS - OPTIONAL ACCESSORIES - VENTING

FLUSH-MOUNT VENT TERMINATION KIT 51W11 (US) or 51W12 (CANADA)

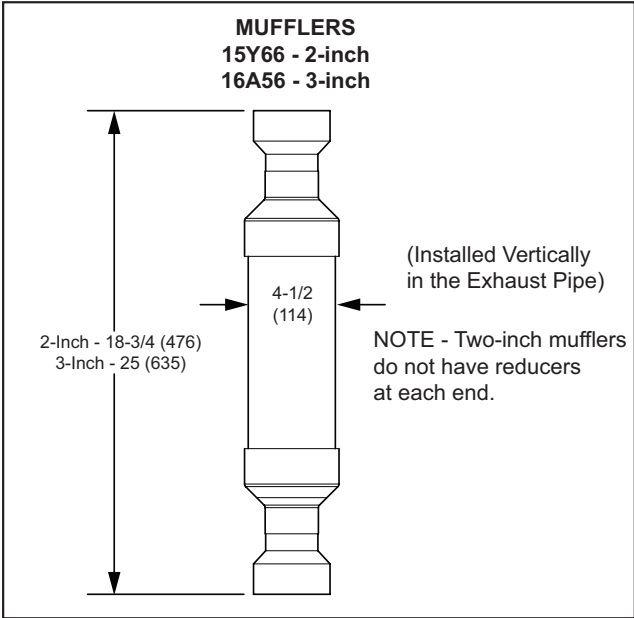
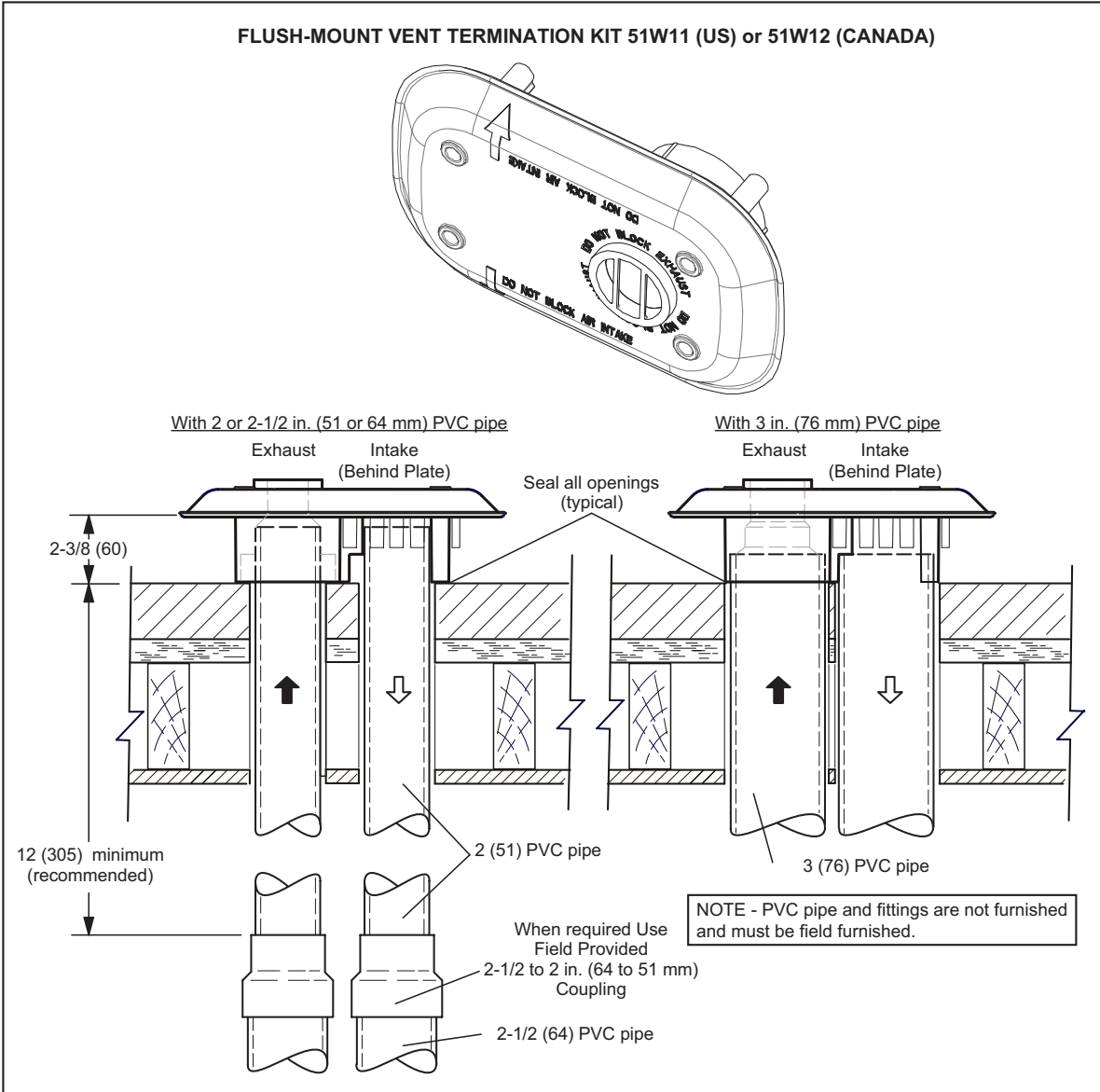

DIMENSIONS - OPTIONAL ACCESSORIES - VENTING

**CONCENTRIC WALL
TERMINATION APPLICATIONS**

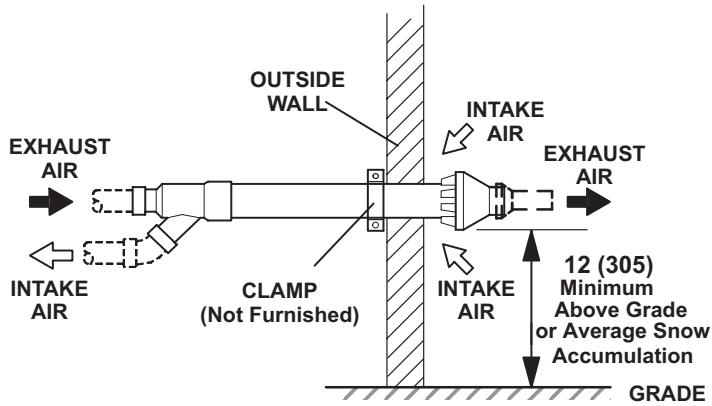

**CONCENTRIC ROOF
TERMINATION APPLICATIONS**

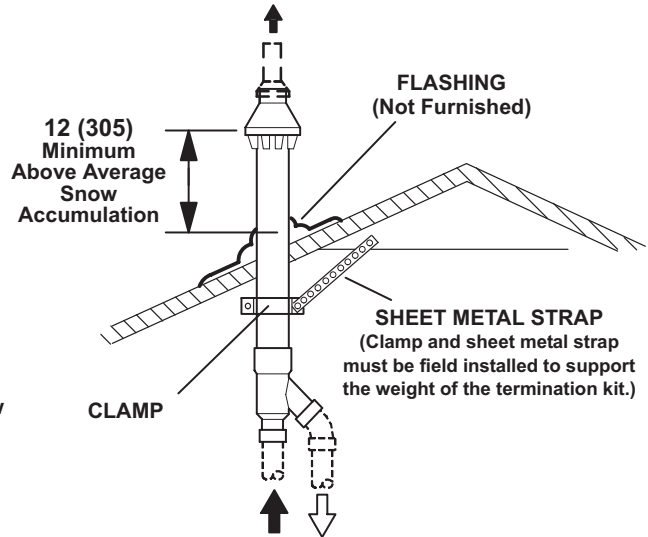

**71M80 / 69M29 / 44W92 – 2 inch kits
60L46 / 44W93 – 3 inch kits**
See Installation Instructions for additional information.

Note - Field provided reducer may be required to adapt different vent pipe sizes to termination.

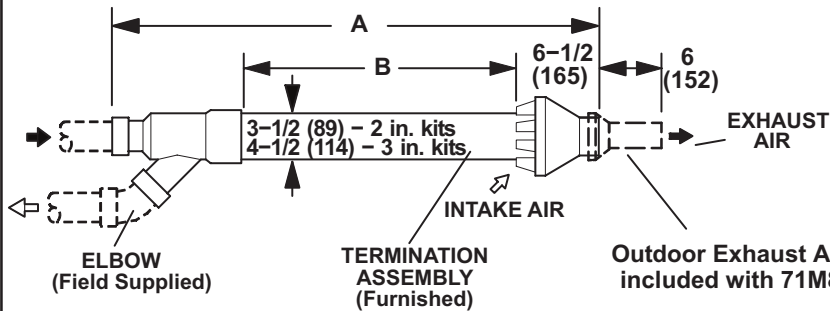

Cat. No.	A		B	
	in.	mm	in.	mm
71M80 69M29	33-3/8	848	16-3/4	425
44W92 (Canada)	29	737	15-1/2	394
60L46	38-7/8	987	21-3/16	538
44W93 (Canada)	36-1/8	918	19-1/2	495

NOTE – Typical illustration for dimensions only. Design may vary depending on kit ordered.

**WALL TERMINATION KITS (CLOSE-COUPLE)
EXTENDED VENT FOR GRADE CLEARANCE
2 inch (51 mm) 22G44 (US)
3 inch (76 mm) 44J40 (US)**

See Installation Instructions for additional information.

Note - Field provided reducer may be required to adapt different vent pipe sizes to termination.

If Intake and Exhaust Pipe is less than 12 in. (305 mm) above snow accumulation or other obstructions, field fabricated piping must be installed.

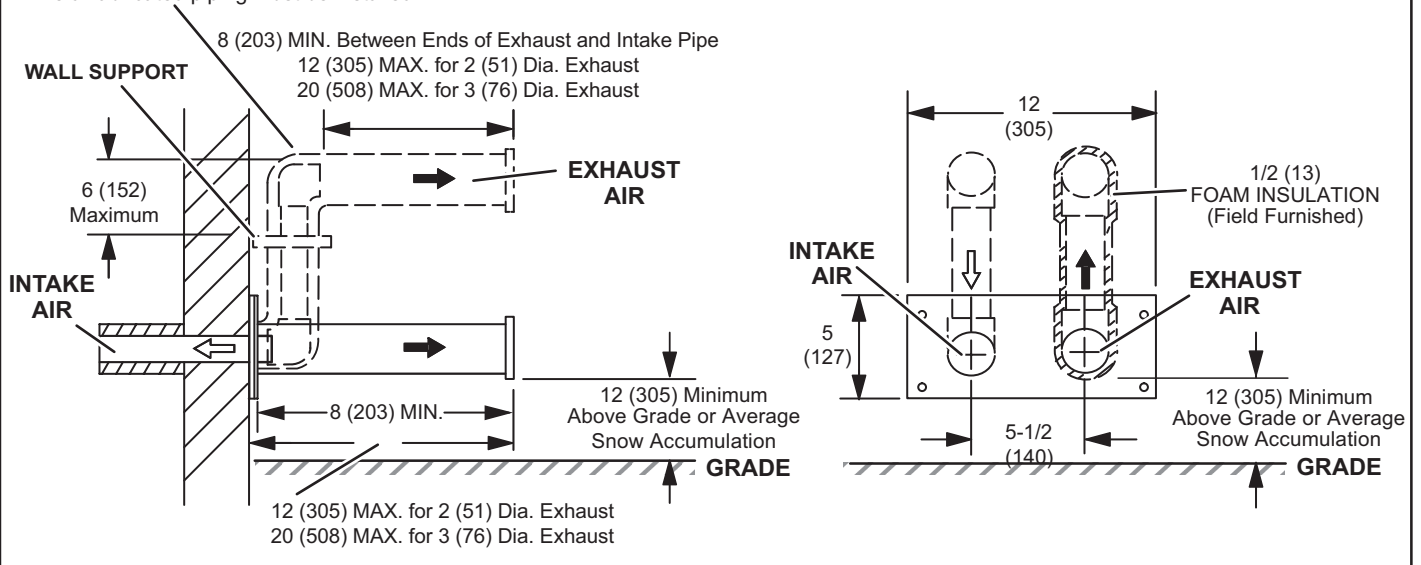

**WALL TERMINATION KITS (CLOSE-COUPLE)
EXTENDED VENT FOR GRADE CLEARANCE
2 inch (51 mm) 30G28 (WTK Canada)
3 inch (76 mm) 81J20 (WTK Canada)**

See Installation Instructions for additional information.

Note - Field provided reducer may be required to adapt different vent pipe sizes to termination.

If Intake and Exhaust Pipe is less than 12 in. (305 mm) above snow accumulation or other obstructions, field fabricated piping must be installed.

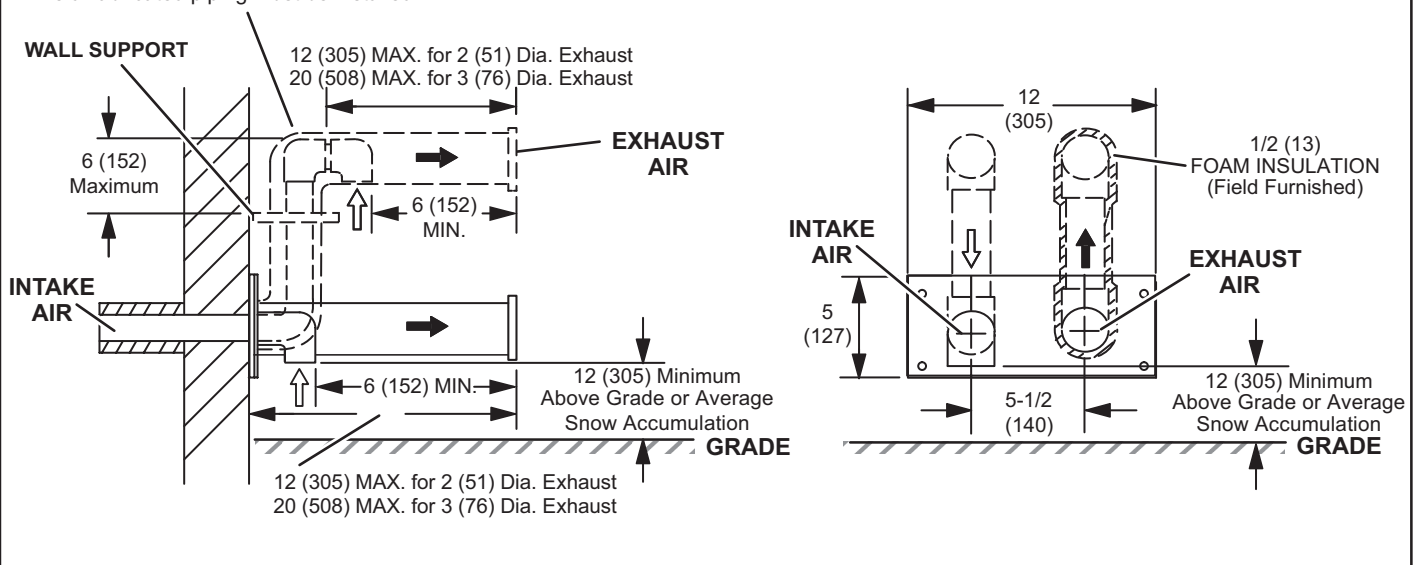

BLOWER DATA

ML296UH045XV36BK BLOWER PERFORMANCE (less filter)

BOTTOM RETURN AIR, SINGLE SIDE RETURN AIR OR SIDE RETURN AIR WITH OPTIONAL RETURN AIR BASE

0 through 0.8 in. w.g. (Heating) and 0 through 1.0 in. w.g. (Cooling) External Static Pressure Range

"ADJUST" Switch Positions	Speed Switch Positions							
	Second Stage "HEAT" Speed - cfm				Second Stage "COOL" Speed - cfm			
	Low	Med-Low	¹ Med-High	High	Low	Med-Low	Med-High	¹ High
+	765	860	960	1050	885	1095	1210	1370
¹ NORM	690	775	855	950	800	990	1115	1255
—	610	710	770	845	710	880	995	1115
"ADJUST" Switch Positions	First Stage "HEAT" Speed - cfm				First Stage "COOL" Speed - cfm			
	Low	Med-Low	¹ Med-High	High	Low	Med-Low	Med-High	¹ High
	+	700	790	855	925	615	780	900
¹ NORM	640	705	780	840	565	690	800	895
—	550	645	700	755	500	615	715	790

¹ Factory default jumper setting.

NOTES - The effect of static pressure is included in air volumes shown.

First stage HEAT is approximately **91%** of the same second stage HEAT speed position.

First stage COOL (two-stage air conditioning units only) is approximately **70%** of the same second stage COOL speed position.

Continuous Fan Only speed is approximately **38%** of the same second stage COOL speed position.

Lennox® LZSV Variable Zoning System Applications - Minimum blower speed is 300 cfm.

ML296UH045XV36BK BLOWER MOTOR WATTS (COOLING)

Jumper Speed Positions	Motor Watts @ Various External Static Pressures - in. wg.																	
	First Stage								Second Stage									
	0.1	0.2	0.3	0.4	0.5	0.6	0.7	0.8	0.1	0.2	0.3	0.4	0.5	0.6	0.7	0.8	0.9	1.0

"+" (Plus) SETTING ("Adjust" Jumper at "+" Setting)

"COOL" Speed	Low	35	58	79	99	125	148	168	197	89	112	140	171	193	222	247	267	295	321
	Med-Low	73	98	120	141	169	187	212	242	147	181	209	243	277	301	333	350	390	409
	Med-High	98	123	148	174	196	225	248	274	199	237	268	302	341	371	403	431	459	498
	High	121	146	182	208	236	261	287	319	282	321	360	394	438	474	501	530	529	526

"NORM" (Normal) SETTING ("Adjust" Jumper at "NORM" Setting)

"COOL" Speed	Low	42	61	77	98	118	140	167	191	60	93	116	141	172	196	219	248	271	294
	Med-Low	42	74	95	126	148	169	194	219	116	146	174	211	237	259	291	315	349	369
	Med-High	61	94	122	149	175	200	223	249	161	195	229	260	289	321	346	375	408	435
	High	98	125	150	174	201	223	254	284	222	256	292	324	363	399	426	455	483	515

"—" (Minus) SETTING ("Adjust" Jumper at "—" Setting)

"COOL" Speed	Low	33	47	66	85	104	125	149	167	51	77	98	120	143	167	193	214	242	260
	Med-Low	46	63	80	101	129	152	171	201	91	113	144	172	194	219	245	271	299	321
	Med-High	59	87	112	133	157	184	205	231	126	154	186	209	233	265	293	322	342	377
	High	73	99	130	152	176	200	223	249	169	201	233	265	284	327	349	386	408	444

BLOWER DATA

ML296UH070XV36BK BLOWER PERFORMANCE (less filter)

BOTTOM RETURN AIR, SINGLE SIDE RETURN AIR OR SIDE RETURN AIR WITH OPTIONAL RETURN AIR BASE

0 through 0.8 in. w.g. (Heating) and 0 through 1.0 in. w.g. (Cooling) External Static Pressure Range

"ADJUST" Switch Positions	Speed Switch Positions							
	Second Stage "HEAT" Speed - cfm				Second Stage "COOL" Speed - cfm			
	Low	Med-Low	¹ Med-High	High	Low	Med-Low	Med-High	¹ High
+	955	1025	1085	1175	920	1095	1235	1330
¹ NORM	880	935	990	1070	840	990	1120	1200
—	790	840	890	965	750	885	1000	1075
"ADJUST" Switch Positions	First Stage "HEAT" Speed - cfm				First Stage "COOL" Speed - cfm			
	Low	Med-Low	¹ Med-High	High	Low	Med-Low	Med-High	¹ High
	+	865	925	980	1055	655	780	850
¹ NORM	795	845	900	975	580	700	765	850
—	715	770	805	865	515	630	690	760

¹ Factory default jumper setting.

NOTES - The effect of static pressure is included in air volumes shown.

First stage HEAT is approximately **90%** of the same second stage HEAT speed position.

First stage COOL (two-stage air conditioning units only) is approximately **70%** of the same second stage COOL speed position.

Continuous Fan Only speed is approximately **38%** of the same second stage COOL speed position.

Lennox® LZSV Variable Zoning System Applications - Minimum blower speed is 300 cfm.

ML296UH070XV36BK BLOWER MOTOR WATTS (COOLING)

Jumper Speed Positions	Motor Watts @ Various External Static Pressures - in. wg.																	
	First Stage								Second Stage									
	0.1	0.2	0.3	0.4	0.5	0.6	0.7	0.8	0.1	0.2	0.3	0.4	0.5	0.6	0.7	0.8	0.9	1.0

"+" (Plus) SETTING ("Adjust" Jumper at "+" Setting)

"COOL" Speed	Low	56	79	101	124	146	164	192	214	110	139	167	190	223	249	268	297	321	347
	Med-Low	72	103	126	151	174	199	222	243	163	196	230	260	295	318	353	381	414	438
	Med-High	94	118	147	170	197	221	246	274	220	256	295	328	362	392	433	461	498	520
	High	110	146	173	200	224	255	280	306	272	311	348	387	418	457	496	529	529	525

"NORM" (Normal) SETTING ("Adjust" Jumper at "NORM" Setting)

"COOL" Speed	Low	45	66	89	109	132	151	174	196	88	115	146	170	190	219	243	263	287	312
	Med-Low	63	87	112	135	158	180	199	226	127	158	187	221	250	277	301	329	357	389
	Med-High	79	107	130	153	173	198	219	241	180	210	245	278	306	340	372	392	421	460
	High	93	123	154	176	202	228	252	272	217	250	288	320	355	388	415	445	471	498

"—" (Minus) SETTING ("Adjust" Jumper at "—" Setting)

"COOL" Speed	Low	45	61	77	97	117	144	162	190	76	99	123	145	170	194	214	236	262	290
	Med-Low	48	70	96	114	137	157	182	207	99	126	157	184	208	234	260	281	312	335
	Med-High	61	82	104	129	150	174	196	222	133	162	194	224	251	280	305	333	357	386
	High	68	98	123	147	173	195	218	241	188	211	229	258	277	307	327	354	379	404

BLOWER DATA

ML296UH090XV48CK BLOWER PERFORMANCE (less filter)

BOTTOM RETURN AIR, SINGLE SIDE RETURN AIR OR SIDE RETURN AIR WITH OPTIONAL RETURN AIR BASE

0 through 0.8 in. w.g. (Heating) and 0 through 1.0 in. w.g. (Cooling) External Static Pressure Range

"ADJUST" Switch Positions	Speed Switch Positions							
	Second Stage "HEAT" Speed - cfm				Second Stage "COOL" Speed - cfm			
	Low	Med-Low	¹ Med-High	High	Low	Med-Low	Med-High	¹ High
+	1205	1290	1330	1555	1135	1355	1525	1765
¹ NORM	1075	1155	1200	1410	1080	1270	1435	1655
—	970	1040	1085	1250	940	1115	1255	1460
"ADJUST" Switch Positions	First Stage "HEAT" Speed - cfm				First Stage "COOL" Speed - cfm			
	Low	Med-Low	¹ Med-High	High	Low	Med-Low	Med-High	¹ High
	+	1125	1205	1245	1475	830	985	1095
¹ NORM	1040	1110	1135	1345	765	920	1040	1195
—	935	1000	1030	1210	675	795	900	1040

¹ Factory default jumper setting.

NOTES - The effect of static pressure is included in air volumes shown.

First stage HEAT is approximately **95%** of the same second stage HEAT speed position.

First stage COOL (two-stage air conditioning units only) is approximately **70%** of the same second stage COOL speed position.

Continuous Fan Only speed is approximately **38%** of the same second stage COOL speed position.

Lennox® LZSV Variable Zoning System Applications - Minimum blower speed is 380 cfm.

ML296UH090XV48CK BLOWER MOTOR WATTS (COOLING)

Jumper Speed Positions	Motor Watts @ Various External Static Pressures - in. wg.																		
	First Stage								Second Stage										
	0.1	0.2	0.3	0.4	0.5	0.6	0.7	0.8	0.1	0.2	0.3	0.4	0.5	0.6	0.7	0.8	0.9	1.0	
"+" (Plus) SETTING ("Adjust" Jumper at "+" Setting)																			
"COOL" Speed	Low	71	94	117	144	164	186	207	234	135	165	194	219	243	274	299	330	351	378
	Med-Low	94	121	146	169	193	214	245	266	208	240	270	302	329	361	392	422	449	481
	Med-High	122	154	174	204	228	260	282	305	284	314	351	382	412	451	484	517	550	578
	High	174	202	229	262	286	315	343	372	441	481	514	550	584	623	659	701	735	768
"NORM" (Normal) SETTING ("Adjust" Jumper at "NORM" Setting)																			
"COOL" Speed	Low	67	86	105	125	145	169	186	211	130	154	178	199	225	250	273	297	324	345
	Med-Low	87	110	131	153	176	197	221	241	187	213	242	265	290	314	346	371	404	430
	Med-High	114	140	163	182	209	229	257	281	248	273	301	330	358	380	412	451	473	507
	High	156	183	208	232	254	278	304	332	368	397	428	459	491	519	552	582	611	652
"—" (Minus) SETTING ("Adjust" Jumper at "—" Setting)																			
"COOL" Speed	Low	43	66	88	109	132	152	170	193	93	116	139	164	194	218	239	264	286	315
	Med-Low	59	84	109	133	156	176	199	223	134	164	187	215	242	268	295	322	346	366
	Med-High	79	102	131	155	177	207	223	252	170	196	230	255	284	311	338	369	394	419
	High	113	138	162	188	215	242	266	294	254	283	315	345	376	416	447	475	510	535

BLOWER DATA

ML296UH110XV60CK BLOWER PERFORMANCE (less filter)

BOTTOM RETURN AIR, SINGLE SIDE RETURN AIR OR SIDE RETURN AIR WITH OPTIONAL RETURN AIR BASE

NOTE - Air volumes in **bold** (over 1800 cfm) must have one of the following:

- Single side return air and Optional Return Air Base with transition that must accommodate required 20 x 25 x 1 inch air filter to maintain proper velocity
- Bottom return air
- Return air from both sides
- Bottom and one side return air

0 through 0.8 in. w.g. (Heating) and 0 through 1.0 in. w.g. (Cooling) External Static Pressure Range

"ADJUST" Switch Positions	Speed Switch Positions							
	Second Stage "HEAT" Speed - cfm				Second Stage "COOL" Speed - cfm			
	Low	Med-Low	¹ Med-High	High	Low	Med-Low	Med-High	¹ High
+	1680	1805	1950	2105	1405	1620	1820	2055
¹ NORM	1550	1665	1800	1950	1255	1455	1655	1860
—	1400	1505	1625	1750	1145	1335	1515	1700
"ADJUST" Switch Positions	First Stage "HEAT" Speed - cfm				First Stage "COOL" Speed - cfm			
	Low	Med-Low	¹ Med-High	High	Low	Med-Low	Med-High	¹ High
	+	1290	1390	1505	1615	1015	1165	1325
¹ NORM	1170	1270	1375	1475	905	1055	1200	1335
—	1070	1160	1250	1345	800	950	1080	1220

¹ Factory default jumper setting.

NOTES - The effect of static pressure is included in air volumes shown.

First stage HEAT is approximately **75%** of the same second stage HEAT speed position.

First stage COOL (two-stage air conditioning units only) is approximately **70%** of the same second stage COOL speed position.

Continuous Fan Only speed is approximately **38%** of the same second stage COOL speed position.

Lennox® LZSV Variable Zoning System Applications - Minimum blower speed is 460 cfm.

ML296UH110XV60CK BLOWER MOTOR WATTS (COOLING)

Jumper Speed Positions	Motor Watts @ Various External Static Pressures - in. wg.																		
	First Stage									Second Stage									
	0.1	0.2	0.3	0.4	0.5	0.6	0.7	0.8	0.1	0.2	0.3	0.4	0.5	0.6	0.7	0.8	0.9	1.0	
"+" (Plus) SETTING ("Adjust" Jumper at "+" Setting)																			
"COOL" Speed	Low	90	110	135	155	179	207	228	246	196	225	258	286	318	347	380	404	427	456
	Med-Low	120	142	172	196	223	251	274	301	286	321	360	391	424	452	484	515	549	585
	Med-High	162	197	221	251	280	303	334	360	379	418	457	494	529	567	602	642	674	713
	High	220	251	284	312	343	372	401	434	539	580	625	661	696	742	783	823	866	902
"NORM" (Normal) SETTING ("Adjust" Jumper at "NORM" Setting)																			
"COOL" Speed	Low	72	94	117	141	160	184	207	231	147	177	207	231	261	289	310	342	366	399
	Med-Low	98	126	147	172	196	223	244	267	210	244	276	306	334	362	395	422	453	486
	Med-High	134	160	187	211	237	261	289	313	296	334	369	405	434	474	506	538	568	600
	High	176	200	232	258	287	317	345	370	411	457	488	531	565	597	638	672	705	748
"—" (Minus) SETTING ("Adjust" Jumper at "-" Setting)																			
"COOL" Speed	Low	54	83	103	123	147	166	187	206	113	138	169	193	217	246	270	293	320	343
	Med-Low	79	103	127	149	175	193	215	239	166	198	228	251	280	310	340	364	396	419
	Med-High	105	136	159	184	207	230	256	278	231	266	294	325	359	392	419	447	480	514
	High	129	154	185	211	237	263	290	312	316	349	386	423	453	490	519	552	583	614

REVISIONS

Sections	Description of Change
Approvals	Updated ENERGY STAR® usage.
Control Options	Updated to reflect latest product offering.
Dimensions	Updated Furnace/Coil Combined Dimensions to add latest product offering.



Visit us at www.Lennox.com

For the latest technical information, www.LennoxPros.com

Contact us at 1-800-9-LENNOX

NOTE - Due to Lennox' ongoing commitment to quality, Specifications, Ratings and Dimensions subject to change without notice and without incurring liability. Improper installation, adjustment, alteration, service or maintenance can cause property damage or personal injury. Installation and service must be performed by a qualified installer and servicing agency.

©2026 Lennox Industries, Inc.