

# ZHD

## RAIDER® ROOFTOP UNITS

Standard Efficiency | **R-454B** | 60Hz

### COMMERCIAL PRODUCT SPECIFICATIONS (EHB)



3 to 5 Tons

Net Cooling Capacity - 35,000 to 57,000 Btuh

Net Heating Capacity - 32,600 to 55,000 Btuh

Optional Electric Heat - 5 to 22.5 kW

# RAIDER

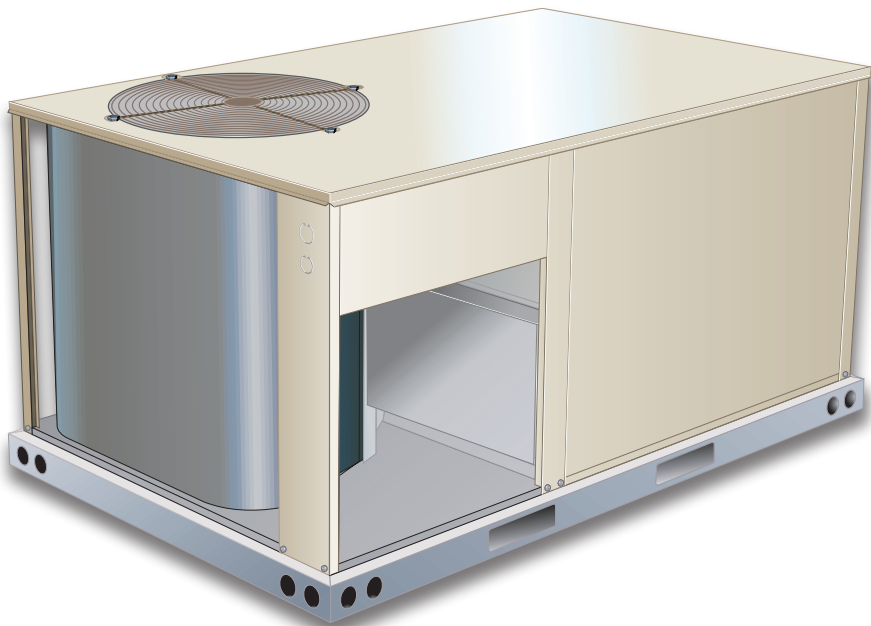

ASHRAE  
Standard  
**90.1**

## MODEL NUMBER IDENTIFICATION

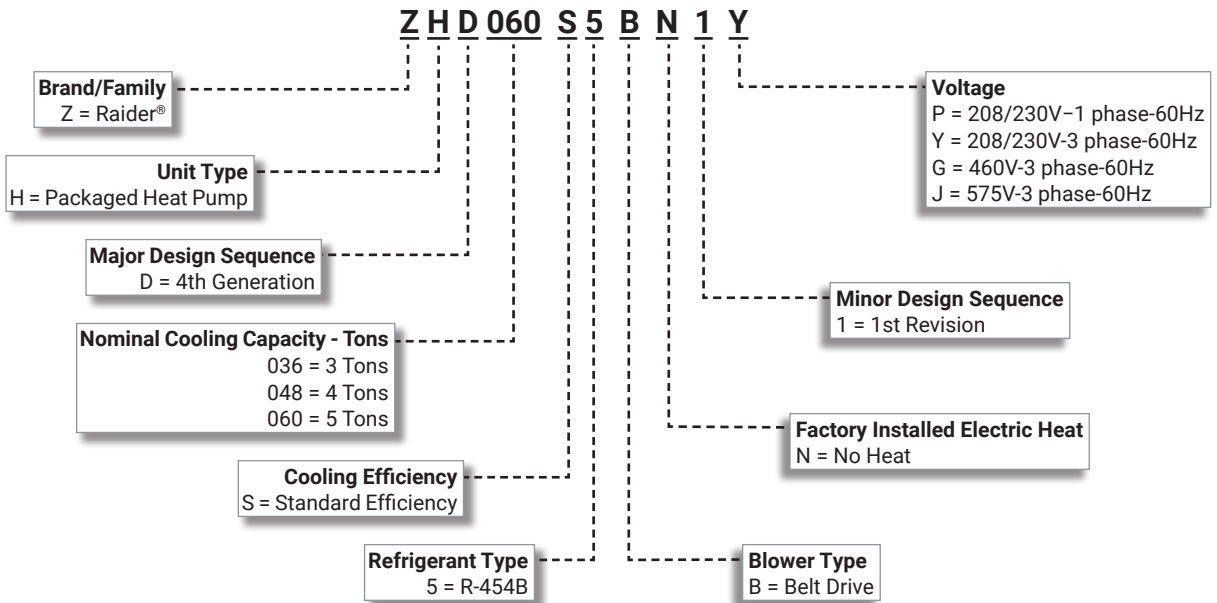

## FEATURE HIGHLIGHTS

Raider® rooftop units from Lennox Commercial are the new standard for cost efficient reliable, efficient rooftop units built for long-lasting performance that can significantly improve indoor environments.

1. Scroll Compressor
2. Copper Tube Coil Construction
3. Outdoor Coil Fan Motor
4. Heavy Gauge Steel Cabinet
5. Smoke Detector (option)  
(Supply and Return)
6. Supply Air Blower
7. Disconnect Switch (option)
8. Electric Heat (option)
9. GFI Service Outlet (option)

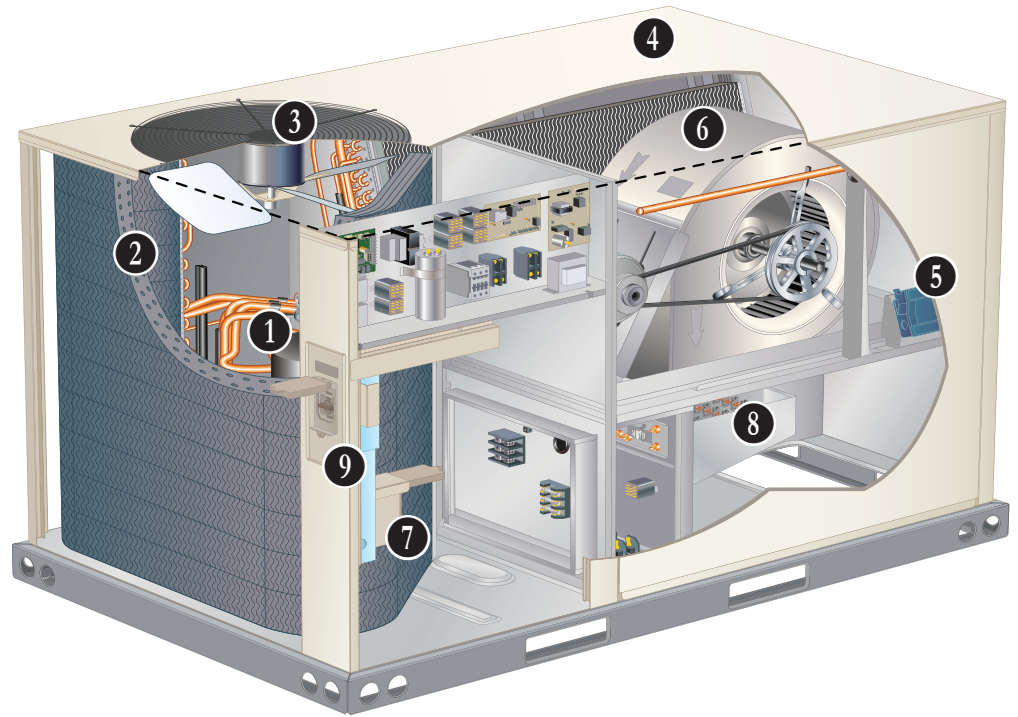

## CONTENTS

Approvals And Warranty . . . . .	3
Blower Data . . . . .	15
Cooling / Heating Ratings . . . . .	13
Dimensions . . . . .	27
- Accessories . . . . .	28
- Unit . . . . .	27
Electrical Accessories . . . . .	23
- Disconnects . . . . .	23
- Fuse Blocks . . . . .	23
Electrical/Electric Heat Data . . . . .	20
Electric Heat Capacities . . . . .	24
Features And Benefits . . . . .	3
Model Number Identification. . . . .	1
Optional Conventional Temperature Control Systems . . . . .	9
Options / Accessories . . . . .	10
Outdoor Sound Data . . . . .	24
Specifications . . . . .	12
Unit Clearances . . . . .	25
Weight Data . . . . .	26

## APPROVALS AND WARRANTY

### APPROVALS

- All 2-5 ton models are AHRI Standard 210/240-2024 certified
- All 6 ton models are AHRI Standard 340/360-2022 certified
- ETL and CSA listed
- All models are ASHRAE 90.1-2025 compliant
- All models meet DOE 2023 energy efficiency standards
- All models are listed to UL 60335-1 and UL 60335-2-40 and meet the Refrigerant Detection and Dissipation Requirements
- Components are bonded for grounding to meet safety standards for servicing required by ETL, NEC and CEC
- All 6 ton models meet California Code of Regulations, Title 24 and ASHRAE 90.1-2025 Section 6.4.3.10 requirements for staged airflow
- All models have been sound tested in accordance with test conditions included in AHRI Standard 270 or 370
- All models have FSA approval and are compliant with standard ASCE 7-22 (ASD) and the Florida Building Code Eighth Edition (2023)
- Units are charged with virgin refrigerant to comply with NYCRR Part 494
- All models are fully charged and run tested to verify unit operation and functionality

### WARRANTY

- Compressors - Limited five years
- High Performance Economizers (optional) - Limited five years
- All other covered components - Limited one year

## FEATURES AND BENEFITS

### COOLING / HEATING SYSTEM

- Designed to maximize sensible and latent cooling performance at design conditions
- System can operate from 35°F to 125°F without any additional controls

#### R-454B Refrigerant

- Low GWP (Global Warming Potential)
- Zero ODP (Ozone Depletion Potential)
- Low Toxicity/Lower Flammability - A2L
- Unit is factory pre-charged

#### 1 Compressor

- Scroll compressors for high performance, reliability and quiet operation
- Resiliently mounted on rubber grommets for quiet operation

#### Compressor Crankcase Heater

- Protects against refrigerant migration that can occur during low ambient operation or during extended off cycles

#### Refrigerant Metering Orifice

Accurately meters refrigerant in system

- Refrigerant control is accomplished by exact sizing of refrigerant metering orifice

#### Filter/Drier

- High capacity filter/drier protects the system from dirt and moisture

#### High Pressure Switch

- Protects the compressor from overload conditions such as dirty condenser coils, blocked refrigerant flow, or loss of outdoor fan operation

#### Low Pressure Switch

- Protects the compressor from low pressure conditions such as low refrigerant charge or low/no airflow

#### Reversing Valve

- 4-way interchange reversing valve rapidly changes the direction of refrigerant flow resulting in quick changeover from cooling to heating and vice versa

#### 2 Coil Construction

- Copper tube construction
- Enhanced rippled-edge aluminum fins
- Flared shoulder tubing connections
- Silver soldered construction
- Factory leak tested

#### Indoor Coil

- Cross-row circuiting with rifled tubing optimizes both sensible and latent cooling capacity

#### Antimicrobial Condensate Drain Pan

- Composite pan, sloped to meet drainage requirements of ASHRAE 62.1
- Antimicrobial additive resists growth of mold and mildew on drain pan, which improves indoor air quality and reduces drain line blockage
- End drain connection

#### 3 Outdoor Coil Fan Motor

- Thermal overload protected
- Totally enclosed
- Permanently lubricated bearings
- Shaft down
- Fan guard mount

#### Outdoor Coil Fan Guard

- PVC coated fan guard furnished

## FEATURES AND BENEFITS

### **COOLING / HEATING SYSTEM (continued)**

#### Required Selections

##### Cooling Capacity

- Specify nominal cooling capacity

#### Options/Accessories

##### **Field Installed**

##### Condensate Drain Trap

- Available in copper or PVC

##### Drain Pan Overflow Switch

- Monitors condensate level in drain pan
- Shuts down unit if drain becomes clogged

##### Low Ambient Kit

- Cycles the outdoor fans while allowing compressor operation in the cooling cycle
- Intermittent fan operation allows the system to operate without icing the evaporator coil and losing capacity
- Designed for use in ambient temperatures no lower than 0°F

### **LOW GWP REFRIGERANT DETECTION SYSTEM (RDS)**

- Complies with UL 60335-2-40 approved standard
- Required for all systems using R-454B refrigerant
- Factory installed on all units
- Consists of a refrigerant detection sensor(s) and a mitigation control
- Ensures safe operation for systems equipped with R-454B refrigerant
- Sensor(s) monitors indoor coil area for R-454B refrigerant
- If R-454B refrigerant is detected the refrigerant detection system will prevent compressor and heating operation until R-454B refrigerant is no longer detected
- Refrigeration detection system energizes blower if any R-454B refrigerant is detected to mitigate any concentrations of refrigerant from the unit and the system

### **CABINET**

#### **4** Construction

- Heavy-gauge steel panels
- Full perimeter heavy-gauge galvanized steel base rail
- Base rails have rigging holes
- Three sides of the base rail have forklift slots
- Raised edges around duct and power entry openings in the bottom of the unit for water protection

##### Airflow Choice

- Units are shipped in downflow (vertical) return air flow configuration

**NOTE** - Units can be field converted to horizontal airflow.

##### Power Entry

- Electrical lines can be routed through the unit base or through horizontal access knock-outs on the end of unit
- See dimension drawing

**NOTE** - Optional Bottom Power Entry Kit is available.

##### Exterior Panels

- Constructed of heavy-gauge, galvanized steel
- Textured pre-paint with polyurethane finish
- Cyclic salt fog and UV exposure up to 1,680 hours per ASTM D5894

##### Insulation

- All panels adjacent to conditioned air are fully insulated with non-hygroscopic fiberglass insulation

##### Access Panels

- Compressor
- Heating
- Controls
- Blower
- Air filter/economizer section

#### Options/Accessories

##### **Field Installed**

##### Combination Coil/Hail Guards

- Heavy gauge steel frame
- Painted to match cabinet
- Expanded metal mesh protects outdoor coil

## FEATURES AND BENEFITS

### **CONTROLS**

#### **Compressor Monitor**

- Anti-short cycle control (5 minutes)
- High and low pressure switch monitoring with five-strike lockout protection
- LEDs for diagnostic and troubleshooting
- On-board defrost relays (fan, reversing valve, aux. heat)
- Field selectable frost accumulation timing
- Field selectable compressor delay

#### **Refrigerant Detection System (RDS) Control**

- Monitors leak detection sensor
- Terminal strip for thermostat, float switch and RDS alarm connections
- LED for power and sensor status

#### **24V Transformer**

- For all control voltage
- Resettable pop-up fuse

### **Options/Accessories**

#### **Field Installed**

##### **5 Smoke Detector**

- Photoelectric type
- Installed in supply air section, return air section or both sections
- Available with power board and single sensor (supply or return) or power board and two sensors (supply and return)
- Power board located in unit blower compartment

#### **Thermostats**

- Control system and thermostat options, see page 9

### **BLOWER**

A wide selection of supply air blower options are available to meet a variety of air flow requirements

##### **6 Motor**

- Overload protected
- Ball bearings
- Belt drive motors are offered on all models and are available in several different sizes to maximize air performance

#### **Supply Air Blower**

- Forward curved blades
- Blower wheel statically and dynamically balanced.
- Ball bearings
- Adjustable pulley (allows speed change)

### **Required Selections**

#### **Supply Air Blower**

- Order blower motor horsepower and drive kit number required when base unit is ordered
- See Drive Kit Specifications Table

## FEATURES AND BENEFITS

### ELECTRICAL

#### Marked & Color-Coded Wiring

- All electrical wiring is color-coded and marked to identify which components it is connecting.

#### Electrical Plugs

- Positive connection electrical plugs are used to connect common accessories or maintenance parts for easy removal or installation.

### Required Selections

#### Voltage Choice

- Specify when ordering base unit.

### Options/Accessories

#### **Factory or Field Installed**

##### **7** Disconnect Switch

- Accessible from outside of unit
- Spring loaded weatherproof cover furnished

#### **Field Installed**

#### Bottom Power Entry Kit

- Kit reduces the number of penetrations in the roof
- Kit includes bulkhead connectors to provides power and control wiring routing through the roof curb

##### **8** Electric Heat

- Helix wound nichrome elements
- Individual element limit controls
- Wiring harness

**NOTE** - See Options / Accessories tables for ordering information.

**NOTE** - Unit Fuse Block is required and must be ordered separately. See Electrical / Electric Heat tables for ordering information.

##### **9** GFI Service Outlets (2)

- 115V ground fault circuit interrupter (GFCI) type
- Field installed, non-powered, field-wired
- Waterproof heavy-duty UV resistant polycarbonate case cover furnished

### **INDOOR AIR QUALITY**

#### Air Filters

- Disposable 2 inch MERV 4 filters furnished as standard

### Options/Accessories

#### **Field Installed**

#### Indoor Air Quality (CO<sub>2</sub>) Sensor

- Monitors CO<sub>2</sub> levels adjusts economizer dampers as needed for Demand Control Ventilation

## OPTIONS / ACCESSORIES

### **ECONOMIZER**

#### Economizer (Downflow or Horizontal) (Standard and High Performance Common Features)

- Outdoor Air Hood is furnished
- Includes Barometric Relief Dampers with Exhaust Hood
- Barometric Relief Dampers allow relief of excess air,
- Aluminum blade dampers prevent blow back and outdoor air infiltration during off cycle
- Exhaust hood with bird screen furnished
- Demand Control Ventilation (DCV) ready using optional CO<sub>2</sub> sensors
- Single temperature control is furnished with Economizer
- Outdoor air sensor enables Economizer if the outdoor temperature is less than the setpoint of the control

**NOTE** - Horizontal Economizer is field installed only.

#### **Field Installed**

#### Standard Economizer Features (Not for Title 24)

- Gear-driven action
- Return air and outdoor air dampers
- Plug-in connections to unit
- Nylon bearings
- Neoprene seals
- 24-volt
- Fully-modulating spring return motor

#### Standard Economizer Control Module

The Standard Economizer Control Module can be adjusted to operate based on outdoor air temperatures



#### Economizer Controls:

- **Damper Minimum Position** - Can be set lower than traditional minimum air requirements resulting in cost savings
- **IAQ Sensor** - Signals dampers to modulate and maintain 55°F when CO<sub>2</sub> is higher than the CO<sub>2</sub> setpoint
- **Demand Control Ventilation (DCV) LED** - A steady green Demand Control Ventilation LED indicates the IAQ reading is higher than setpoint and requires more fresh air
- **Free Cool LED** - A steady green LED indicates outdoor air is suitable for free cooling

**NOTE** - Free Cooling runs when outdoor air temperature is lower than the set temperature on the economizer control.

**NOTE:** The Free Cooling default setting for outdoor air temperature sensor is 55°F.

## OPTIONS / ACCESSORIES

### **ECONOMIZER (continued)**

#### **Factory or Field Installed**

##### **High Performance Economizer Control Module**

- Provides inputs and outputs to control economizer based on parameter settings
- Free cooling based on single dry bulb temperature, or combination temperature + humidity sensors
- Automatic switchover for different control modes
- Parameter settings based on climate zone, using GPS functionality in the Climatix Mobile application
- LED indication for free cooling operation, sensor operation and damper operation
- Quick installation and easy commissioning with the Climatix Mobile App on a mobile device

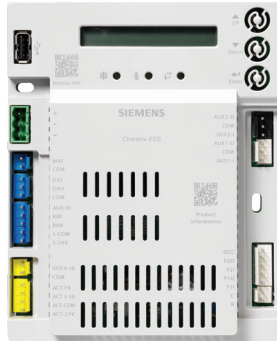

**NOTE** - WLAN Stick is required for App connection to module(s).

- Module displays any alarm messages (fault detection and diagnostics) as an aid in troubleshooting
- RS585 port for BACnet MSTP or Modbus RTU communication
- USB port for firmware updates and WLAN connection for setup and commissioning
- QR codes on module for quick access to download Climatix Mobile App and user documentation
- User Interface for normal operation, parameter setup and, alarm notifications with an LCD display and three operation buttons:
  1. **Up Button** - Move to the previous value, step or category
  2. **Down Button** - Move to the next value, step or category
  3. **Enter Button** -
    - Press to edit the current value or option
    - Press to confirm a newly selected value or option
    - Press Enter + Up to jump up one category
    - Press Enter + Down to jump down one category

**NOTE** - The Free Cooling setpoint for Title 24 applications must be set based on the Climate Zone where the system is installed. See Section 140.4 "Prescriptive Requirements for Space Conditioning Systems" of the California Energy Commission's 2013 Building Energy Efficiency Standards.

**NOTE** - Refer to Installation Instructions for complete setup information and menu parameters available.

#### **Field Installed**

##### **Single Enthalpy Temperature Control**

- Outdoor air enthalpy sensor enables economizer if the outdoor enthalpy is less than the setpoint of the control

##### **Differential Enthalpy Control (Not for Title 24)**

- Order one for factory installed economizer
- Order two for field installed economizer
  - One is field installed in the return air section
  - One in the outdoor air section
- Allows the economizer control board to select between outdoor air or return air, whichever has lower enthalpy

##### **WLAN Stick**

- Required for Climatix Mobile App usage
- Plugs into USB port on Module to provide a temporary WLAN connection for setup, commissioning, and servicing

**NOTE** - Only one WLAN Stick is required and can be used on multiple modules.

## OPTIONS / ACCESSORIES

### **EXHAUST**

#### **Field Installed**

##### **Power Exhaust Fan - Downflow or Horizontal**

- Installs external to unit for applications with Economizer option
- Provides exhaust air pressure relief
- Interlocked to run when supply air blower is operating
- Fan runs when outdoor air dampers are 50% open (adjustable)
- Motor is overload protected
- Fan is 12 in. diameter
- Five fan blades
- 1/2 HP motor.

**NOTE** - Not available for 460V.

### **OUTDOOR AIR**

#### **Field Installed**

##### **Outdoor Air Dampers - Downflow**

- Single blade damper
- 0 to 25% (fixed) outdoor air adjustable
- Installs in unit
- Motorized model features fully modulating spring return damper motor with plug-in connection
- Manual model features a slide damper

**NOTE** - Maximum mixed air temperature in cooling mode is 100°F.

### **ROOF CURBS**

#### **Field Installed**

##### **Hybrid Roof Curbs, Downflow**

- Nail strip furnished; mates to unit
- US National Roofing Contractors approved
- Shipped knocked down
- Interlocking tabs fasten corners together
- No tools required for assembly
- Can also be fastened together with furnished hardware
- Available in 8, 14, 18, and 24 inch heights

##### **Adaptor Curbs (not shown)**

- Curbs are regionally sourced
- Dimensions will vary based upon the source

**NOTE** - Contact your local sales representative for a detailed cut sheet with applicable dimensions

### **CEILING DIFFUSERS**

#### **Field Installed**

- Flush or Step-Down
- White powder coat finish on diffuser face and grilles
- Insulated UL listed duct liner
- Diffuser box has collars for duct connection
- Step-down diffusers have double deflection blades
- Flush diffusers have fixed blades
- Provisions for suspending
- Internally sealed to prevent recirculation
- Removable return air grille
- Adapts to T-bar ceiling grids or plaster ceilings

##### **Transitions (Supply and Return)**

**NOTE** - Ceiling Diffuser Transitions are not furnished and must be field fabricated.

## OPTIONAL CONVENTIONAL TEMPERATURE CONTROL SYSTEMS

### CS7500 Commercial 7-Day Programmable Thermostat



- Premium Universal Thermostat
- Full Color Touchscreen Interface
- Up To 4 Heat / 3 Cool
- Built-In Sensors For Temperature and Humidity
- Remote Sensors Options For Temperature, Discharge Air, Outdoor Air
- 5-2 or 7-Day Scheduling
- Smooth Setback Recovery
- Heat/Cool Auto-Changeover
- FDD, ASHRAE, IECC Compliant

### CS3000 Commercial 5-2 Day Programmable Thermostat

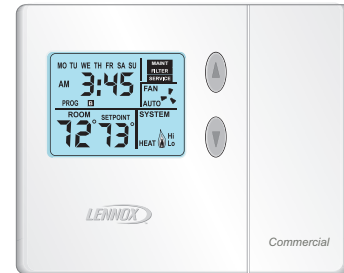

- Conventional Multi-Stage Thermostat
- Intuitive Display
- Push-Button Operation
- Up To 2 Heat / 2 Cool
- Built-In Temperature Sensor
- Remote Temperature Sensing
- Up to 5-2 Day Scheduling
- Smooth Setback Recovery
- Heat/Cool Auto-changeover

### BACnet Compatible Thermostat With Reheat



Description	Order Number
<b>CS7500 Commercial 7-Day Programmable Thermostat</b>	
CS7500 7-Day Thermostat	<b>24K41</b>
Sensors/ Accessories	1 Remote non-adjustable wall-mount 20k <b>47W36</b>
	1 Remote non-adjustable wall-mount 10k <b>47W37</b>
	Remote non-adjustable discharge air (duct mount) <b>19L22</b>
	Outdoor temperature sensor <b>X2658</b>
<b>CS3000 5-2 Day Programmable Thermostat</b>	
CS3000 5-2 Day Thermostat	<b>11Y05</b>
Sensor/ Accessories	Remote non-adjustable wall mount 10k averaging <b>47W37</b>
	Thermostat wall mounting plate <b>X2659</b>
<b>BACnet 7-Day Programmable Thermostat</b>	
BACnet Controls	<sup>2</sup> 7-Day BACnet Thermostat <b>24C57</b>
	<sup>3</sup> BACnet Module <b>16X70</b>
<sup>4</sup> BACnet Room Sensors	With Display <b>97W23</b>
	Without Display <b>97W24</b>
<b>Universal Thermostat Guard with Lock (clear)</b>	
	Inside Dimensions (H x W x D) 5-7/8 x 8-3/8 x 3 in. <b>39P21</b>

<sup>1</sup> Remote wall-mount sensors can be applied in any of the following combinations:  
 One Sensor - (1) 47W36, Two Sensors - (2) 47W37, Three Sensors - (2) 47W36 and (1) 47W37  
 Four Sensors - (4) 47W36, Five Sensors - (3) 47W36 and (2) 47W37

<sup>2</sup> BACnet Thermostat (24C57) will control units with and without the Humiditrol® option. If there is a mix of units equipped with and without Humiditrol on the same site, this thermostat can be used for all units if suitable.

<sup>3</sup> Not compatible with units equipped with Humiditrol® option.

<sup>4</sup> Only compatible with BACnet Module (16X70).

- 7-Day Programmable
- For units with or without Humiditrol®
- BTL listed MS/TP ensures compatibility with any BACnet system
- Built-in control programs for conventional and heat pump applications
- Conventional systems up to 3-stage heat and 3-stage cool
- Heat pumps with 1 or 2 compressors and up to 2-stage auxiliary heat
- On-board temperature and humidity sensor
- Multiple configurable inputs and outputs enable advanced control strategies
- Set-up Wizard enables rapid system configuration
- No special tools required for installation or commissioning
- Seven-day (2, 4 or 6 event) occupancy scheduling per day
- Backlit 5-inch LCD touchscreen

## OPTIONS / ACCESSORIES

Item	Order Number	Size			
		036	048	060	
<b>COOLING/HEATING SYSTEM</b>					
Condensate Drain Trap	PVC	<b>38R23</b>	X	X	X
	Copper	<b>38V21</b>	X	X	X
Drain Pan Overflow Switch		<b>38A64</b>	X	X	X
Low Ambient Kit		<b>99W68</b>	X	X	X
<b>BLOWER - SUPPLY AIR</b>					
Motors	Belt Drive - .75 HP (203/230V-1ph)	Factory	O		
	Belt Drive - 1 HP (208/230V, 460V, 575V-3ph)	Factory	O	O	
	Belt Drive - 1.5 HP (208/230V-1ph)	Factory		O	O
	Belt Drive - 1.5 HP (208/230V, 460V, 575V-3ph)	Factory			O
Drive Kits See Blower Data Tables for selection	Kit #ZA01 - 678-1035 rpm	Factory	O		
	Kit #ZA02 - 803-1226 rpm	Factory		O	
	Kit #ZA04 - 964-1471 rpm	Factory	O		
	Kit #ZAA01 - 522-784 rpm	Factory			O
	Kit #ZAA02 - 632-875 rpm	Factory			O
	Kit #ZAA03 - 798-1105 rpm	Factory			O
<b>CONTROLS</b>					
Smoke Detector - Supply or Return (Power board and one sensor)		<b>39U76</b>	X	X	X
Smoke Detector - Supply and Return (Power board and two sensors)		<b>39U75</b>	X	X	X
<b>NOTE - See Conventional Thermostat Control Systems on page XX for Additional Options.</b>					
<b>ELECTRICAL</b>					
Voltage 60 Hz	208/230V - 1 phase	Factory	O	O	O
	208/230V - 3 phase	Factory	O	O	O
	460V - 3 phase	Factory	O	O	O
	575V - 3 phase	Factory	O	O	O
Bottom Power Entry Kit		<b>98W08</b>	X	X	X
Disconnect	See Electrical/Electric Heat Tables for selection		OX	OX	OX
GFI Service Outlets with Cover	15 amp non-powered, field-wired (208/230V, 460V only)	<b>39U74</b>	X	X	X
	20 amp non-powered, field-wired (208/230V, 460V, 575V)	<b>39U77</b>	X	X	X
<b>ELECTRIC HEAT</b>					
5 kW	208/240V-1ph	<b>30U97</b>	X	X	X
	208/240V-3ph	<b>30U98</b>	X	X	X
	460V-3ph	<b>30U99</b>	X	X	X
	575V-3ph	<b>30V01</b>	X	X	X
7.5 kW	208/240V-1ph	<b>30V02</b>	X	X	X
	208/240V-3ph	<b>30V03</b>	X	X	X
	460V-3ph	<b>30V04</b>	X	X	X
	575V-3ph	<b>30V05</b>	X	X	X
10 kW	208/240V-1ph	<b>30V06</b>	X	X	X
	208/240V-3ph	<b>30V07</b>	X	X	X
	460V-3ph	<b>30V08</b>	X	X	X
	575V-3ph	<b>30V09</b>	X	X	X
15 kW	208/240V-1ph	<b>30V10</b>	X	X	X
	208/240V-3ph	<b>30V11</b>	X	X	X
	460V-3ph	<b>30V12</b>	X	X	X
	575V-3ph	<b>30V13</b>	X	X	X
22.5 kW	208/240V-1ph	<b>30V14</b>		X	X
	208/240V-3ph	<b>30V15</b>		X	X
	460V-3ph	<b>30V16</b>		X	X
	575V-3ph	<b>30V17</b>		X	X

NOTE - Order numbers shown are for ordering field installed accessories.

OX - Field Installed or Configure to Order (Factory Installed)

O - Configure to Order (Factory Installed)

X - Field Installed.

## OPTIONS / ACCESSORIES

Item	Order Number	Size		
		036	048	060
<b>ELECTRICAL ACCESSORIES</b>				
Unit Fuse Block (required) - See Electrical/Electric Heat Tables for Selection		X	X	X
<b>CABINET</b>				
Coil/Hail Guards	12X19	X	X	X
<b>ECONOMIZER</b>				
<b>Standard Economizer With Outdoor Air Hood (Not for Title 24)</b>				
Standard Economizer (Downflow) Includes Barometric Relief Dampers and Exhaust Hood	14D94	X	X	X
Standard Economizer (Horizontal) Includes Barometric Relief Dampers and Exhaust Hood	14D92	X	X	X
<b>Standard Economizer Controls (Not for Title 24)</b>				
Single Enthalpy Control	21Z09	X	X	X
<b>High Performance Economizer (Sensible Control) (Approved for California Title 24 Building Standards / AMCA Class 1A Certified)</b>				
High Performance Economizer (Downflow) Includes Barometric Relief Dampers and Exhaust Hood	24J59	OX	OX	OX
High Performance Economizer (Horizontal) Includes Barometric Relief Dampers and Exhaust Hood	24J60	X	X	X
<b>High Performance Economizer Controls</b>				
Single Enthalpy Control	23G26	X	X	X
<b>OUTDOOR AIR</b>				
<b>Outdoor Air Dampers - Includes Outdoor Air Hood</b>				
Motorized	15D19	X	X	X
Manual	15D20	X	X	X
<b>POWER EXHAUST FAN</b>				
Standard Static (Downflow) 208/230V-1 or 3ph	21E01	X	X	X
Standard Static (Horizontal) 208/230V-1 or 3ph	24E01	X	X	X
575V Transformer Kit 575V-3ph	59E02	X	X	X
NOTE - Order 575V Transformer Kit with 208/230V Power Exhaust Fan for 575V applications.				
<b>INDOOR AIR QUALITY</b>				
<b>Indoor Air Quality (CO<sub>2</sub>) Sensors</b>				
Sensor - Wall-mount, off-white plastic cover with LCD display	77N39	X	X	X
Sensor - Wall-mount, black plastic case, no display, rated for plenum mounting	87N54	X	X	X
CO <sub>2</sub> Sensor Duct Mounting Kit - for downflow applications	23Y47	X	X	X
Aspiration Box - for duct mounting non-plenum rated CO <sub>2</sub> sensor (77N39)	90N43	X	X	X
<b>ROOF CURBS</b>				
<b>Hybrid Roof Curbs, Downflow</b>				
8 in. height	11F76	X	X	X
14 in. height	11F77	X	X	X
18 in. height	11F78	X	X	X
24 in. height	11F79	X	X	X
<b>CEILING DIFFUSERS</b>				
Step-Down - Order one RTD9-65S	13K60	X	X	X
Flush - Order one FD9-65S	13K55	X	X	X

NOTE - Ceiling Diffuser Transitions are not furnished and must be field fabricated.

NOTE - Order numbers shown are for ordering field installed accessories.

OX - Field Installed or Configure to Order (Factory Installed)

O - Configure to Order (Factory Installed)

X - Field Installed.

## SPECIFICATIONS

Model		ZHD036S5B	ZHD048S5B	ZHD060S5B	
<b>Nominal Tonnage</b>		3	4	5	
<b>Efficiency Type</b>		Standard	Standard	Standard	
<b>Blower Type</b>		Single Speed Belt Drive	Single Speed Belt Drive	Single Speed Belt Drive	
<b>Cooling Performance</b>	Gross Cooling Capacity (Btuh)	36,300	47,900	59,700	
	<sup>1</sup> Net Cooling Capacity (Btuh)	35,000	45,000	57,000	
	<sup>1</sup> AHRI Rated Air Flow (cfm)	1400	1420	2015	
	<sup>1</sup> SEER2 (Btuh/Watt)	13.4	13.4	13.4	
	<sup>1</sup> EER2 (Btuh/Watt)	10.6	10.6	10.6	
	Total Unit Power (kW)	3.0	4.1	5.2	
<b>Heating Performance</b>	<sup>1</sup> Total High Heating Capacity (Btuh)	32,600	42,500	55,000	
	<sup>1</sup> AHRI Rated Air Flow (cfm)	1400	1420	2015	
	<sup>1</sup> HSPF2 (Region IV)	6.7	6.7	6.7	
	<sup>1</sup> HSPF2 (Region V)	5.68	5.60	5.90	
	<sup>1</sup> COP	3.40	3.30	3.50	
	Total Unit Power (kW)	2.9	3.9	4.5	
	<sup>1</sup> Total Low Heating Capacity (Btuh)	17,800	24,000	30,000	
	<sup>1</sup> COP	2.0	2.0	2.1	
	Total Unit Power (kW)	2.7	3.5	4.2	
<b>Sound Rating Number</b>	dBA	79	78	82	
<b>Refrigerant Charge</b>	Refrigerant Type	R-454B	R-454B	R-454B	
	Charge Furnished	14 lbs. 8 oz.	14 lbs. 2 oz.	13 lbs. 5 oz.	
<b>Electric Heat Available - See page 10</b>		5, 7.5, 10, 15 kW	5, 7.5, 10, 15, 22.5 kW		
<b>Compressor Type (one per unit)</b>		Single-Stage Scroll (1)			
<b>Outdoor Coil</b>	Net face area - ft. <sup>2</sup>	19.9	19.9	19.9	
	Tube diameter - in.	3/8	3/8	3/8	
	Rows	2	2	2	
	Fins - in.	20	20	20	
<b>Outdoor Coil Fan</b>	Motor HP (number and type)	1/4 (1 PSC)	1/4 (1 PSC)	1/3 (1 PSC)	
	Rpm	825	825	1075	
	Watts	300	300	350	
	Diameter (Number) - in.	(1) 22	(1) 22	(1) 22	
	Blades	4	4	3	
	Total air volume - cfm	3335	3335	3600	
<b>Indoor Coil</b>	Net face area - ft. <sup>2</sup>	9.6	10.8	10.8	
	Tube diameter - in.	3/8	3/8	3/8	
	Rows	3	3	3	
	Fins - in.	14	14	14	
	Condensate drain size (NPT) - in.	(1) 3/4	(1) 3/4	(1) 3/4	
	Expansion device type	Balanced Port Thermostatic Expansion Valve			
<b>Indoor Blower</b>	Nominal Motor HP	1ph	0.75	1.5	1.5
		3ph	1	1	1.5
	Maximum Usable Motor HP	0.86, 1.15	1.7, 1.15	1.7	
	Available Drive Kits	Kit #ZA01 678-1035 rpm Kit #ZA04 964-1471 rpm	Kit #ZA02 803-1226 rpm	Kit #ZAA01 522-784 rpm Kit #ZAA02 632-875 rpm Kit #ZAA03 798-1105 rpm	
		Wheel (Number) diameter x width - in.	(1) 10 x 10	(1) 10 x 10	(1) 15 x 9
<b>Filters</b>	Type	Disposable			
	Number and size - in.	(4) 16 x 20 x 2	(2) 16 x 20 x 2 (2) 20 x 20 x 2		
<b>Line voltage data (Volts-Phase-Hz)</b>		208/230V-1-60 208/230V-3-60 460V-3-60 575V-3-60	208/230V-1-60 208/230V-3-60 460V-3-60 575V-3-60	208/230V-1-60 208/230V-3-60 460V-3-60 575V-3-60	

NOTE - Net capacity includes evaporator blower motor heat deduction. Gross capacity does not include evaporator blower motor heat deduction.

<sup>1</sup> AHRI Certified to AHRI Standard 210/240:

**Cooling Ratings** - 95°F outdoor air temperature and 80°F db/67°F wb entering indoor coil air.

**High Temperature Heating Ratings** - 47°F db/43°F wb outdoor air temperature and 70°F entering indoor coil air.

**Low Temperature Heating Ratings** - 17°F db/15°F wb outdoor air temperature and 70°F entering indoor coil air.

<sup>2</sup> Using total air volume and system static pressure requirements determine from blower performance tables rpm and motor HP required. Maximum usable HP of motors furnished are shown. In Canada, nominal motor HP is also maximum usable motor HP output. If motors of comparable HP are used, be sure to keep within the service factor limitations outlined on the motor nameplate.

## COOLING / HEATING RATINGS

NOTE – For Temperatures and Capacities not shown in tables, see bulletin – Cooling Unit Rating Table Correction Factor Data in Miscellaneous Engineering Data section.

### 3 TON COOLING STANDARD EFFICIENCY ZHD036S5

Entering Wet Bulb Temperature	Total Air Volume	Outdoor Air Temperature Entering Outdoor Coil																			
		85°F					95°F					105°F					115°F				
		Total Cool Cap.	Comp. Motor Input	Sensible To Total Ratio (S/T)			Total Cool Cap.	Comp. Motor Input	Sensible To Total Ratio (S/T)			Total Cool Cap.	Comp. Motor Input	Sensible To Total Ratio (S/T)			Total Cool Cap.	Comp. Motor Input	Sensible To Total Ratio (S/T)		
				Dry Bulb					Dry Bulb					Dry Bulb					Dry Bulb		
cfm	kBtuh	kW	75°F	80°F	85°F	kBtuh	kW	75°F	80°F	85°F	kBtuh	kW	75°F	80°F	85°F	kBtuh	kW	75°F	80°F	85°F	
63°F	960	36.6	2.06	0.75	0.89	1	34.7	2.33	0.77	0.91	1	32.7	2.64	0.79	0.94	1	30.6	3	0.82	0.97	1
	1200	38.3	2.06	0.81	0.97	1	36.4	2.33	0.83	1	1	34.2	2.64	0.86	1	1	32.3	2.99	0.9	1	1
	1440	40	2.06	0.87	1	1	38	2.33	0.9	1	1	36.1	2.63	0.93	1	1	33.9	2.98	0.97	1	1
67°F	960	38.7	2.06	0.61	0.73	0.85	36.8	2.33	0.62	0.75	0.88	34.7	2.64	0.63	0.77	0.91	32.4	2.99	0.65	0.8	0.94
	1200	40.7	2.07	0.64	0.79	0.94	38.3	2.33	0.66	0.82	0.97	36.1	2.63	0.68	0.84	1	33.7	2.98	0.7	0.88	1
	1440	41.9	2.07	0.68	0.85	1	39.6	2.33	0.7	0.88	1	37.2	2.62	0.72	0.92	1	34.6	2.97	0.75	0.96	1
71°F	960	40.6	2.07	0.47	0.59	0.71	38.7	2.33	0.48	0.61	0.73	36.5	2.63	0.48	0.62	0.75	34.2	2.97	0.49	0.64	0.77
	1200	42.7	2.07	0.49	0.64	0.77	40.5	2.33	0.5	0.65	0.79	38.1	2.62	0.51	0.67	0.82	35.7	2.96	0.52	0.69	0.86
	1440	44.1	2.07	0.51	0.68	0.84	41.8	2.32	0.52	0.69	0.86	39.2	2.61	0.54	0.72	0.89	36.6	2.95	0.55	0.74	0.94

### 3 TON HEATING STANDARD EFFICIENCY ZHD036S5

Indoor Coil Air Volume 70°F Dry Bulb cfm	Air Temperature Entering Outdoor Coil									
	65°F		45°F		25°F		5°F		-15°F	
	Total Heating Capacity	Comp. Motor Input	Total Heating Capacity	Comp. Motor Input	Total Heating Capacity	Comp. Motor Input	Total Heating Capacity	Comp. Motor Input	Total Heating Capacity	Comp. Motor Input
	kBtuh	kW	kBtuh	kW	kBtuh	kW	kBtuh	kW	kBtuh	kW
960	42.7	2.48	32.6	2.33	22.7	22.7	12.9	1.94	6.4	1.45
1200	43.6	2.31	33.5	2.16	23.6	2.01	13.7	1.77	7.3	1.29
1440	44.2	2.31	34.1	2.06	24.2	1.91	14.4	1.67	7.9	1.19

### 4 TON COOLING STANDARD EFFICIENCY ZHD048S5

Entering Wet Bulb Temperature	Total Air Volume	Outdoor Air Temperature Entering Outdoor Coil																			
		85°F					95°F					105°F					115°F				
		Total Cool Cap.	Comp. Motor Input	Sensible To Total Ratio (S/T)			Total Cool Cap.	Comp. Motor Input	Sensible To Total Ratio (S/T)			Total Cool Cap.	Comp. Motor Input	Sensible To Total Ratio (S/T)			Total Cool Cap.	Comp. Motor Input	Sensible To Total Ratio (S/T)		
				Dry Bulb					Dry Bulb					Dry Bulb					Dry Bulb		
cfm	kBtuh	kW	75°F	80°F	85°F	kBtuh	kW	75°F	80°F	85°F	kBtuh	kW	75°F	80°F	85°F	kBtuh	kW	75°F	80°F	85°F	
63°F	1280	48.4	2.92	0.75	0.88	1	45.8	3.33	0.77	0.91	1	43.4	3.77	0.78	0.93	1	41	4.26	0.81	0.96	1
	1600	50.5	2.92	0.81	0.96	1	48.1	3.33	0.83	0.99	1	45.6	3.77	0.85	1	1	43.4	4.27	0.88	1	1
	1920	52.6	2.92	0.87	1	1	50.3	3.33	0.89	1	1	48.2	3.78	0.92	1	1	45.6	4.28	0.95	1	1
67°F	1280	51	2.92	0.6	0.73	0.85	48.7	3.33	0.61	0.74	0.87	46.2	3.77	0.62	0.76	0.9	43.6	4.27	0.64	0.78	0.93
	1600	53.3	2.92	0.64	0.79	0.93	51	3.33	0.65	0.81	0.96	48.2	3.78	0.67	0.83	0.99	45.4	4.27	0.68	0.86	1
	1920	55.2	2.91	0.68	0.85	1	52.4	3.33	0.69	0.87	1	49.6	3.78	0.71	0.9	1	46.5	4.28	0.73	0.93	1
71°F	1280	53.7	2.91	0.47	0.59	0.71	51.2	3.33	0.47	0.6	0.72	48.6	3.78	0.48	0.61	0.74	46.1	4.28	0.48	0.62	0.76
	1600	56.2	2.9	0.48	0.63	0.77	53.6	3.32	0.49	0.64	0.79	50.8	3.77	0.5	0.66	0.81	48.1	4.27	0.51	0.67	0.84
	1920	58	2.89	0.5	0.67	0.83	55.2	3.32	0.51	0.69	0.85	52.2	3.77	0.52	0.71	0.88	49.2	4.27	0.53	0.73	0.92

### 4 TON HEATING STANDARD EFFICIENCY ZHD048S5

Indoor Coil Air Volume 70°F Dry Bulb cfm	Air Temperature Entering Outdoor Coil									
	65°F		45°F		25°F		5°F		-15°F	
	Total Heating Capacity	Comp. Motor Input	Total Heating Capacity	Comp. Motor Input	Total Heating Capacity	Comp. Motor Input	Total Heating Capacity	Comp. Motor Input	Total Heating Capacity	Comp. Motor Input
	kBtuh	kW	kBtuh	kW	kBtuh	kW	kBtuh	kW	kBtuh	kW
1280	55.3	3.28	42.6	3.08	30.1	3.1	17.2	2.57	8.6	1.92
1600	56.3	3.07	43.5	2.87	31	2.67	18.1	2.36	9.6	1.71
1920	57	3.07	44.3	2.75	31.7	2.55	18.8	2.24	10.3	1.6

## COOLING / HEATING RATINGS

NOTE – For Temperatures and Capacities not shown in tables, see bulletin – Cooling Unit Rating Table Correction Factor Data in Miscellaneous Engineering Data section.

### 5 TON COOLING STANDARD EFFICIENCY ZHD060S5

Entering Wet Bulb Temperature	Total Air Volume	Outdoor Air Temperature Entering Outdoor Coil																			
		85°F					95°F					105°F					115°F				
		Total Cool Cap.	Comp. Motor Input	Sensible To Total Ratio (S/T)			Total Cool Cap.	Comp. Motor Input	Sensible To Total Ratio (S/T)			Total Cool Cap.	Comp. Motor Input	Sensible To Total Ratio (S/T)			Total Cool Cap.	Comp. Motor Input	Sensible To Total Ratio (S/T)		
				Dry Bulb					Dry Bulb					Dry Bulb					Dry Bulb		
		cfm	kBtuh	kW	75°F	80°F	85°F	kBtuh	kW	75°F	80°F	85°F	kBtuh	kW	75°F	80°F	85°F	kBtuh	kW	75°F	80°F
63°F	1600	58.3	3.61	0.76	0.9	1	55.6	4.09	0.78	0.93	1	52.8	4.65	0.8	0.95	1	49.7	5.27	0.82	0.98	1
	2000	61	3.63	0.83	0.98	1	58.4	4.11	0.84	1	1	55.3	4.67	0.87	1	1	52.5	5.3	0.9	1	1
	2400	63.6	3.64	0.89	1	1	61.1	4.13	0.91	1	1	58	4.69	0.94	1	1	55	5.32	0.97	1	1
67°F	1600	61.6	3.63	0.61	0.74	0.88	58.8	4.12	0.62	0.76	0.89	56	4.67	0.63	0.78	0.92	52.6	5.3	0.65	0.8	0.95
	2000	64.2	3.65	0.65	0.8	0.95	61.2	4.13	0.66	0.82	0.98	58	4.69	0.68	0.85	1	54.6	5.31	0.7	0.88	1
	2400	66.1	3.66	0.69	0.87	1	62.8	4.15	0.7	0.89	1	59.6	4.7	0.72	0.92	1	55.9	5.33	0.75	0.96	1
71°F	1600	64.7	3.65	0.47	0.6	0.72	61.9	4.14	0.48	0.61	0.74	58.8	4.7	0.48	0.62	0.76	55.4	5.32	0.49	0.64	0.78
	2000	67.6	3.66	0.49	0.64	0.79	64.6	4.16	0.5	0.65	0.8	61.3	4.72	0.51	0.67	0.83	57.7	5.34	0.52	0.69	0.86
	2400	69.7	3.68	0.51	0.68	0.85	66.5	4.17	0.52	0.7	0.88	63.1	4.73	0.53	0.72	0.9	59.4	5.36	0.54	0.74	0.94

### 5 TON HEATING STANDARD EFFICIENCY ZHD060S5

Indoor Coil Air Volume 70°F Dry Bulb cfm	Air Temperature Entering Outdoor Coil									
	65°F		45°F		25°F		5°F		-15°F	
	Total Heating Capacity	Comp. Motor Input	Total Heating Capacity	Comp. Motor Input	Total Heating Capacity	Comp. Motor Input	Total Heating Capacity	Comp. Motor Input	Total Heating Capacity	Comp. Motor Input
	kBtuh	kW	kBtuh	kW	kBtuh	kW	kBtuh	kW	kBtuh	kW
1600	68	3.86	52.3	3.65	36.5	3.65	22.1	3.08	11.1	2.3
2000	69	3.62	53.2	3.41	37.5	3.19	23.1	2.85	12.1	2.07
2400	69.7	3.62	54	3.27	38.3	3.06	23.8	2.71	12.9	1.93

**BLOWER DATA**

**ZHD036S5B**

**BLOWER TABLE INCLUDES RESISTANCE FOR BASE UNIT ONLY WITH DRY INDOOR COIL AND AIR FILTERS IN PLACE.**

FOR ALL UNITS ADD:

1 - Any factory installed options air resistance (heat section, economizer, wet coil, etc.).

2 - Any field installed accessories air resistance (duct resistance, diffuser, etc.).

See page 18 for blower motors and drives and wet coil and options/accessory air resistance data.

**DOWNFLOW**

Air Volume cfm	External Static - in. w.g.															
	0.10		0.20		0.30		0.40		0.50		0.60		0.70		0.80	
	RPM	BHP	RPM	BHP	RPM	BHP	RPM	BHP	RPM	BHP	RPM	BHP	RPM	BHP	RPM	BHP
900	562	0.11	621	0.13	685	0.16	752	0.18	818	0.21	883	0.24	944	0.27	1001	0.30
1000	584	0.13	644	0.16	707	0.18	773	0.21	838	0.24	901	0.27	960	0.3	1015	0.33
1100	609	0.16	669	0.18	732	0.21	796	0.24	860	0.27	921	0.30	978	0.34	1031	0.37
1200	635	0.19	696	0.21	758	0.24	821	0.27	883	0.31	942	0.34	997	0.38	1049	0.42
1300	664	0.22	725	0.25	786	0.28	848	0.31	908	0.35	965	0.39	1018	0.43	1068	0.47
1400	696	0.26	756	0.29	816	0.32	876	0.36	935	0.40	989	0.44	1041	0.48	1089	0.52
1500	729	0.30	788	0.33	848	0.37	906	0.41	962	0.45	1015	0.50	1065	0.54	1112	0.58

Air Volume cfm	External Static - in. w.g.															
	0.90		1.00		1.10		1.20		1.30		1.40		1.50		1.60	
	RPM	BHP	RPM	BHP	RPM	BHP	RPM	BHP	RPM	BHP	RPM	BHP	RPM	BHP	RPM	BHP
900	1053	0.32	1103	0.35	1149	0.38	1193	0.41	1234	0.43	1274	0.47	1312	0.50	1351	0.53
1000	1066	0.36	1114	0.39	1160	0.42	1204	0.45	1245	0.48	1284	0.51	1322	0.54	1361	0.58
1100	1081	0.40	1128	0.43	1173	0.46	1216	0.49	1257	0.53	1296	0.56	1334	0.60	1372	0.63
1200	1097	0.45	1144	0.48	1188	0.51	1231	0.54	1271	0.58	1310	0.62	1347	0.66	1385	0.69
1300	1115	0.50	1161	0.53	1204	0.56	1246	0.60	1286	0.64	1325	0.68	1362	0.72	1399	0.76
1400	1135	0.56	1179	0.59	1222	0.62	1264	0.66	1303	0.70	1341	0.75	1378	0.79	1415	0.83
1500	1157	0.62	1200	0.65	1242	0.69	1282	0.73	1321	0.77	1359	0.82	1396	0.86	1431	0.91

**HORIZONTAL**

Air Volume cfm	External Static - in. w.g.															
	0.10		0.20		0.30		0.40		0.50		0.60		0.70		0.80	
	RPM	BHP	RPM	BHP	RPM	BHP	RPM	BHP	RPM	BHP	RPM	BHP	RPM	BHP	RPM	BHP
900	560	0.16	624	0.18	692	0.20	761	0.21	830	0.23	896	0.25	956	0.27	1012	0.29
1000	583	0.18	647	0.20	715	0.22	783	0.24	850	0.25	914	0.27	972	0.30	1025	0.33
1100	609	0.20	673	0.22	740	0.24	808	0.26	873	0.28	934	0.31	990	0.34	1041	0.37
1200	637	0.23	702	0.25	769	0.27	835	0.29	898	0.32	956	0.35	1009	0.38	1058	0.41
1300	669	0.26	734	0.28	800	0.30	863	0.33	924	0.36	979	0.39	1030	0.43	1077	0.46
1400	704	0.29	768	0.32	832	0.35	894	0.37	951	0.41	1004	0.44	1052	0.48	1097	0.52
1500	742	0.33	805	0.36	867	0.39	925	0.42	980	0.46	1030	0.50	1076	0.54	1119	0.58

Air Volume cfm	External Static - in. w.g.															
	0.90		1.00		1.10		1.20		1.30		1.40		1.50		1.60	
	RPM	BHP	RPM	BHP	RPM	BHP	RPM	BHP	RPM	BHP	RPM	BHP	RPM	BHP	RPM	BHP
900	1064	0.32	1114	0.35	1162	0.38	1208	0.41	1251	0.45	1293	0.49	1333	0.52	1373	0.56
1000	1076	0.36	1124	0.39	1170	0.42	1216	0.46	1259	0.49	1300	0.53	1340	0.57	1379	0.61
1100	1089	0.40	1136	0.43	1181	0.46	1225	0.50	1268	0.54	1308	0.58	1347	0.62	1386	0.66
1200	1104	0.45	1150	0.48	1194	0.51	1237	0.55	1279	0.59	1319	0.63	1357	0.67	1394	0.71
1300	1121	0.5	1165	0.53	1209	0.57	1251	0.61	1292	0.65	1331	0.69	1368	0.73	1405	0.78
1400	1140	0.56	1183	0.59	1225	0.63	1266	0.67	1306	0.71	1345	0.76	1382	0.8	1417	0.85
1500	1161	0.62	1202	0.65	1243	0.69	1284	0.73	1323	0.78	1360	0.83	1396	0.87	1432	0.92

**BLOWER DATA**

**ZHD048S5B**

**BLOWER TABLE INCLUDES RESISTANCE FOR BASE UNIT ONLY WITH DRY INDOOR COIL AND AIR FILTERS IN PLACE.**

FOR ALL UNITS ADD:

1 - Any factory installed options air resistance (heat section, economizer, wet coil, etc.).

2 - Any field installed accessories air resistance (duct resistance, diffuser, etc.).

See page 18 for blower motors and drives and wet coil and options/accessory air resistance data.

**DOWNFLOW**

Air Volume cfm	External Static - in. w.g.															
	0.10		0.20		0.30		0.40		0.50		0.60		0.70		0.80	
	RPM	BHP	RPM	BHP	RPM	BHP	RPM	BHP	RPM	BHP	RPM	BHP	RPM	BHP	RPM	BHP
1200	620	0.23	681	0.29	744	0.34	809	0.39	875	0.43	941	0.47	1004	0.51	1060	0.54
1300	652	0.28	713	0.34	775	0.39	839	0.44	903	0.48	967	0.51	1025	0.55	1078	0.59
1400	687	0.33	747	0.39	809	0.44	871	0.49	934	0.53	994	0.57	1048	0.61	1098	0.64
1500	724	0.40	784	0.45	844	0.50	905	0.54	965	0.59	1021	0.62	1071	0.66	1118	0.70
1600	764	0.46	823	0.51	882	0.56	940	0.60	997	0.65	1048	0.69	1094	0.72	1140	0.75
1700	806	0.53	863	0.58	919	0.62	975	0.67	1028	0.71	1075	0.75	1119	0.78	1164	0.81
1800	849	0.60	903	0.65	957	0.69	1010	0.74	1058	0.78	1102	0.82	1145	0.85	1189	0.88
1900	892	0.68	944	0.72	995	0.77	1045	0.82	1089	0.86	1131	0.89	1174	0.92	1217	0.95
2000	935	0.76	984	0.81	1033	0.86	1079	0.91	1122	0.95	1163	0.97	1204	1.00	1247	1.03

Air Volume cfm	External Static - in. w.g.															
	0.90		1.00		1.10		1.20		1.30		1.40		1.50		1.60	
	RPM	BHP	RPM	BHP	RPM	BHP	RPM	BHP	RPM	BHP	RPM	BHP	RPM	BHP	RPM	BHP
1200	1111	0.58	1156	0.60	1199	0.62	1241	0.63	1284	0.65	1326	0.67	1367	0.71	1408	0.74
1300	1127	0.62	1172	0.65	1214	0.66	1256	0.68	1299	0.70	1341	0.73	1381	0.77	1421	0.81
1400	1145	0.68	1189	0.70	1231	0.72	1274	0.74	1316	0.76	1357	0.79	1397	0.83	1436	0.88
1500	1164	0.73	1208	0.75	1251	0.78	1293	0.80	1334	0.83	1374	0.86	1413	0.91	1451	0.95
1600	1185	0.79	1229	0.81	1271	0.84	1313	0.86	1354	0.90	1393	0.94	1431	0.98	1468	1.03
1700	1208	0.84	1252	0.87	1294	0.90	1335	0.94	1375	0.98	1413	1.02	1449	1.07	1485	1.12
1800	1233	0.91	1276	0.94	1318	0.98	1358	1.02	1397	1.06	1434	1.11	1469	1.16	1504	1.21
1900	1261	0.98	1303	1.02	1343	1.06	1382	1.11	1420	1.16	1455	1.21	1490	1.26	1525	1.31
2000	1289	1.07	1330	1.11	1370	1.16	1407	1.21	1444	1.27	1478	1.32	1513	1.37	1547	1.42

**HORIZONTAL**

Air Volume cfm	External Static - in. w.g.															
	0.10		0.20		0.30		0.40		0.50		0.60		0.70		0.80	
	RPM	BHP	RPM	BHP	RPM	BHP	RPM	BHP	RPM	BHP	RPM	BHP	RPM	BHP	RPM	BHP
1200	614	0.21	681	0.25	752	0.30	821	0.34	888	0.39	950	0.43	1006	0.46	1057	0.49
1300	644	0.24	712	0.29	782	0.34	850	0.39	915	0.43	974	0.47	1027	0.51	1076	0.53
1400	677	0.29	746	0.34	814	0.39	880	0.44	942	0.48	998	0.52	1049	0.55	1097	0.58
1500	714	0.34	781	0.40	848	0.45	911	0.49	970	0.53	1023	0.57	1072	0.60	1119	0.63
1600	752	0.40	818	0.45	882	0.50	943	0.55	999	0.59	1050	0.62	1097	0.66	1142	0.69
1700	792	0.46	855	0.52	917	0.56	975	0.61	1028	0.64	1077	0.68	1123	0.72	1166	0.75
1800	832	0.53	894	0.58	952	0.63	1007	0.67	1058	0.70	1105	0.74	1149	0.78	1192	0.82
1900	873	0.60	932	0.65	988	0.69	1040	0.73	1088	0.77	1134	0.81	1177	0.85	1219	0.90
2000	914	0.67	970	0.72	1023	0.76	1073	0.80	1120	0.85	1163	0.89	1205	0.94	1246	0.99

Air Volume cfm	External Static - in. w.g.															
	0.90		1.00		1.10		1.20		1.30		1.40		1.50		1.60	
	RPM	BHP	RPM	BHP	RPM	BHP	RPM	BHP	RPM	BHP	RPM	BHP	RPM	BHP	RPM	BHP
1200	1105	0.51	1152	0.53	1197	0.55	1240	0.58	1280	0.61	1320	0.64	1358	0.68	1395	0.72
1300	1123	0.55	1169	0.57	1213	0.60	1255	0.63	1295	0.67	1334	0.70	1372	0.74	1409	0.79
1400	1142	0.60	1187	0.63	1230	0.66	1272	0.69	1312	0.73	1350	0.77	1388	0.82	1424	0.86
1500	1163	0.66	1207	0.69	1249	0.72	1290	0.76	1330	0.80	1368	0.85	1405	0.90	1441	0.94
1600	1185	0.72	1228	0.75	1270	0.79	1310	0.83	1349	0.88	1387	0.93	1423	0.98	1459	1.03
1700	1209	0.78	1251	0.82	1292	0.87	1331	0.92	1370	0.97	1407	1.02	1443	1.07	1478	1.12
1800	1234	0.86	1275	0.91	1315	0.96	1354	1.01	1391	1.06	1428	1.11	1463	1.17	1498	1.22
1900	1260	0.95	1300	1.00	1340	1.05	1377	1.11	1414	1.16	1450	1.22	1485	1.27	1519	1.32
2000	1287	1.04	1326	1.10	1365	1.16	1402	1.21	1437	1.27	1472	1.33	1507	1.38	1541	1.43

**BLOWER DATA**

**ZHD060S5B**

**BLOWER TABLE INCLUDES RESISTANCE FOR BASE UNIT ONLY WITH DRY INDOOR COIL AND AIR FILTERS IN PLACE.**

FOR ALL UNITS ADD:

1 - Any factory installed options air resistance (heat section, economizer, wet coil, etc.).

2 - Any field installed accessories air resistance (duct resistance, diffuser, etc.).

See page 18 for blower motors and drives and wet coil and options/accessory air resistance data.

**DOWNFLOW**

Air Volume cfm	External Static - in. w.g.															
	0.10		0.20		0.30		0.40		0.50		0.60		0.70		0.80	
	RPM	BHP	RPM	BHP	RPM	BHP	RPM	BHP	RPM	BHP	RPM	BHP	RPM	BHP	RPM	BHP
1600	522	0.27	552	0.32	585	0.37	619	0.43	656	0.48	693	0.53	732	0.59	771	0.64
1700	539	0.32	570	0.37	603	0.43	638	0.48	674	0.53	711	0.59	749	0.64	787	0.69
1800	558	0.38	589	0.43	623	0.48	658	0.54	694	0.59	730	0.64	767	0.70	803	0.75
1900	578	0.44	610	0.49	643	0.54	678	0.60	714	0.65	749	0.70	785	0.76	819	0.82
2000	600	0.50	632	0.56	665	0.61	699	0.66	734	0.71	769	0.77	803	0.83	837	0.90
2100	623	0.57	655	0.62	688	0.68	721	0.73	755	0.79	789	0.84	822	0.91	854	0.98
2200	647	0.65	678	0.70	711	0.75	743	0.81	776	0.86	809	0.93	841	1.00	872	1.06
2300	671	0.73	702	0.78	734	0.83	766	0.89	798	0.95	829	1.02	860	1.09	890	1.16
2400	696	0.81	726	0.87	757	0.92	788	0.98	819	1.04	850	1.11	880	1.19	909	1.26

Air Volume cfm	External Static - in. w.g.															
	0.90		1.00		1.10		1.20		1.30		1.40		1.50		1.60	
	RPM	BHP	RPM	BHP	RPM	BHP	RPM	BHP	RPM	BHP	RPM	BHP	RPM	BHP	RPM	BHP
1600	809	0.69	844	0.74	877	0.80	908	0.85	936	0.91	963	0.97	989	1.02	1014	1.08
1700	823	0.75	857	0.80	889	0.86	919	0.92	947	0.97	973	1.03	999	1.09	1024	1.14
1800	838	0.81	870	0.87	901	0.92	931	0.98	958	1.04	984	1.10	1009	1.16	1034	1.22
1900	853	0.88	885	0.94	915	0.99	944	1.05	971	1.11	996	1.17	1021	1.23	1045	1.29
2000	869	0.96	899	1.01	929	1.07	957	1.13	984	1.19	1009	1.25	1033	1.31	1058	1.38
2100	885	1.04	915	1.10	944	1.15	971	1.22	997	1.28	1022	1.34	1046	1.40	1070	1.46
2200	902	1.13	931	1.19	959	1.24	986	1.31	1012	1.37	1036	1.43	1060	1.50	1084	1.56
2300	920	1.23	948	1.29	975	1.35	1001	1.41	1027	1.47	1051	1.53	1075	1.60	1098	1.66
2400	938	1.33	965	1.39	992	1.45	1017	1.52	1042	1.58	1066	1.64	1090	1.70	1113	1.77

**HORIZONTAL**

Air Volume cfm	External Static - in. w.g.															
	0.10		0.20		0.30		0.40		0.50		0.60		0.70		0.80	
	RPM	BHP	RPM	BHP	RPM	BHP	RPM	BHP	RPM	BHP	RPM	BHP	RPM	BHP	RPM	BHP
1600	525	0.30	561	0.34	597	0.39	635	0.43	673	0.47	711	0.51	748	0.56	784	0.61
1700	543	0.34	578	0.39	615	0.43	653	0.48	691	0.52	728	0.57	765	0.62	800	0.67
1800	561	0.39	597	0.44	635	0.49	672	0.53	710	0.58	746	0.63	782	0.68	816	0.73
1900	581	0.44	618	0.49	655	0.54	692	0.59	729	0.64	765	0.69	800	0.75	833	0.80
2000	602	0.50	639	0.55	676	0.61	713	0.66	749	0.71	784	0.76	818	0.82	850	0.88
2100	625	0.57	661	0.62	698	0.67	735	0.73	770	0.78	804	0.84	837	0.90	868	0.96
2200	648	0.64	685	0.69	721	0.75	757	0.80	791	0.86	824	0.92	856	0.98	886	1.05
2300	673	0.71	709	0.77	745	0.83	780	0.88	813	0.94	845	1.01	876	1.08	905	1.15
2400	699	0.79	734	0.85	769	0.91	803	0.97	835	1.04	866	1.11	896	1.18	924	1.25

Air Volume cfm	External Static - in. w.g.															
	0.90		1.00		1.10		1.20		1.30		1.40		1.50		1.60	
	RPM	BHP	RPM	BHP	RPM	BHP	RPM	BHP	RPM	BHP	RPM	BHP	RPM	BHP	RPM	BHP
1600	819	0.66	851	0.72	883	0.77	913	0.83	943	0.89	971	0.95	998	1.01	1024	1.07
1700	833	0.72	865	0.78	896	0.84	926	0.90	954	0.96	982	1.02	1009	1.08	1034	1.14
1800	848	0.79	880	0.85	910	0.92	939	0.98	967	1.04	994	1.10	1020	1.16	1045	1.23
1900	864	0.87	895	0.93	924	0.99	953	1.06	980	1.12	1007	1.18	1032	1.25	1056	1.31
2000	881	0.95	911	1.01	940	1.08	967	1.14	994	1.21	1020	1.27	1044	1.34	1068	1.40
2100	898	1.03	927	1.10	955	1.17	982	1.23	1008	1.30	1033	1.37	1057	1.43	1080	1.50
2200	916	1.12	944	1.19	971	1.26	998	1.33	1023	1.40	1047	1.47	1071	1.54	1093	1.60
2300	934	1.22	961	1.29	988	1.36	1014	1.43	1038	1.50	1062	1.58	1085	1.65	1107	1.71
2400	952	1.32	979	1.40	1005	1.47	1030	1.54	1054	1.62	1077	1.69	1099	1.76	1121	1.83

## BLOWER DATA

### BELT DRIVE KIT SPECIFICATIONS - ZHD036-060

Model	Motor HP		Voltage	Speeds	Drive Kits and RPM Range					
	Nominal	Max.			ZA01	ZA02	ZA04	ZAA01	ZAA02	ZAA03
ZHD036	0.75	0.86	208/230V-1ph	1	678 - 1035	---	964 - 1471	---	---	---
	1	1.15	208/230V-3ph	1	678 - 1035	---	964 - 1471	---	---	---
ZHD048	1	1.15	208/230V-3ph	1	---	803 - 1226	---	---	---	---
	1.5	1.7	208/230V-1ph	1	---	803 - 1226	---	---	---	---
ZHD060	1.5	1.7	208/230V-1 or 3ph	1	---	---	---	522-784	632-875	798-1105

NOTE - Using total air volume and system static pressure requirements determine from blower performance tables rpm and motor HP required. Maximum usable HP of motors furnished are shown. In Canada, nominal motor HP is also maximum usable motor HP. If motors of comparable HP are used, be sure to keep within the service factor limitations outlined on the motor nameplate.

### POWER EXHAUST FAN PERFORMANCE

Return Air System Static Pressure - in. w.g.	Air Volume Exhausted cfm
0.00	1865
0.05	1785
0.10	1710
0.15	1630
0.20	1545
0.25	1450
0.30	1350
0.35	1240

### OPTIONS / ACCESSORIES AIR RESISTANCE - in. w.g.

Air Volume cfm	Wet Indoor Coil		Electric Heat	Economizer	
	036	048, 060		Downflow	Horizontal
900	0.01	---	0.05	0.03	0.04
1000	0.01	---	0.06	0.03	0.05
1100	0.02	---	0.08	0.04	0.05
1200	0.02	0.01	0.09	0.05	0.06
1300	0.02	0.02	0.12	0.05	0.07
1400	0.03	0.02	0.17	0.06	0.08
1500	0.03	0.02	0.22	0.07	0.08
1600	0.03	0.03	0.26	0.08	0.09
1700	0.04	0.03	0.30	0.09	0.10
1800	0.04	0.03	0.33	0.10	0.11
1900	0.05	0.04	0.33	0.11	0.12
2000	0.05	0.04	0.31	0.12	0.13
2100	0.06	0.05	0.27	0.13	0.14
2200	0.06	0.05	0.29	0.14	0.15
2300	0.07	0.05	0.31	0.15	0.16
2400	0.07	0.06	0.32	0.16	0.18

## BLOWER DATA

### CEILING DIFFUSERS AIR RESISTANCE (in. w.g.)

Air Volume cfm	RTD9-65S Step-Down Diffuser			FD9-65S Flush Diffuser
	2 Ends Open	1 Side & 2 Ends Open	All Ends & Sides Open	
800	0.15	0.13	0.11	0.11
1000	0.19	0.16	0.14	0.14
1200	0.25	0.20	0.17	0.17
1400	0.33	0.26	0.20	0.20
1600	0.43	0.32	0.20	0.24
1800	0.56	0.40	0.30	0.30
2000	0.73	0.50	0.36	0.36
2200	0.95	0.63	0.44	0.44

### CEILING DIFFUSER AIR THROW DATA

Air Volume - cfm	<sup>1</sup> Effective Throw - ft.	
	RTD9-65S	FD9-65S
800	10 - 17	14 - 18
1000	10 - 17	15 - 20
1200	11 - 18	16 - 22
1400	12 - 19	17 - 24
1600	12 - 20	18 - 25
1800	13 - 21	20 - 28
2000	14 - 23	21 - 29
2200	16 - 25	22 - 30

<sup>1</sup> Effective throw based on terminal velocities of 75 ft. per minute.

**ELECTRICAL/ELECTRIC HEAT DATA**
**3 TON**

Model		ZHD036S5			
<sup>1</sup> Voltage - 60Hz		208/230V - 1 Ph	208/230V - 3 Ph	460V - 3 Ph	575V - 3 Ph
Compressor (Non-Inverter)	Rated Load Amps	14.4	9	4.1	3.3
	Locked Rotor Amps	86	70	39	29
Outdoor Fan Motor (1)	Full Load Amps (1 Non-ECM)	1	1	0.6	0.45
Power Exhaust (1) 0.33 HP	Full Load Amps	2.4	2.4	1.3	1
Service Outlet 115V GFI (amps)		15	15	15	20
Indoor Blower Motor	Horsepower	0.75	1	1	1
	Full Load Amps	7.6	4.6	2.1	1.7
<sup>2</sup> Maximum Overcurrent Protection (MOCP)	Unit Only	40	25	15	15
	With (1) 0.33 HP Power Exhaust	40	25	---	15
<sup>3</sup> Minimum Circuit Ampacity (MCA)	Unit Only	28	18	9	7
	With (1) 0.33 HP Power Exhaust	30	20	---	8

**ELECTRIC HEAT DATA**

Electric Heat Voltage				208	240	208	240	480	600
<sup>2</sup> Maximum Overcurrent Protection (MOCP)	Unit+ Electric Heat	5 kW		50	60	35	35	20	15
		7.5 kW		70	70	40	45	20	20
		10 kW		80	80	45	50	25	20
		15 kW		100	110	60	70	35	25
<sup>3</sup> Minimum Circuit Ampacity (MCA)	Unit+ Electric Heat	5 kW		50	54	31	33	16	13
		7.5 kW		62	67	38	41	20	16
		10 kW		73	80	44	48	24	19
		15 kW		96	106	57	63	31	25
<sup>2</sup> Maximum Overcurrent Protection (MOCP)	Unit+ Electric Heat and (1) 0.33 HP Power Exhaust	5 kW		60	60	35	40	---	15
		7.5 kW		70	70	40	45	---	20
		10 kW		80	90	50	60	---	20
		15 kW		100	110	60	70	---	30
<sup>3</sup> Minimum Circuit Ampacity (MCA)	Unit+ Electric Heat and (1) 0.33 HP Power Exhaust	5 kW		53	56	33	35	---	14
		7.5 kW		64	69	40	43	---	17
		10 kW		75	82	47	51	---	20
		15 kW		98	108	60	66	---	26

NOTE - All units have a minimum Short Circuit Current Rating (SCCR) of 5000 amps.

<sup>1</sup> Extremes of operating range are plus and minus 10% of line voltage.

<sup>2</sup> HACR type breaker or fuse.

<sup>3</sup> Refer to National or Canadian Electrical Code manual to determine wire, fuse and disconnect size requirements.

**ELECTRICAL/ELECTRIC HEAT DATA**
**4 TON**

Model		ZHD048S5			
<sup>1</sup> Voltage - 60Hz		208/230V - 1 Ph	208/230V - 3 Ph	460V - 3 Ph	575V - 3 Ph
Compressor (Non-Inverter)	Rated Load Amps	19.4	12	6.3	4.4
	Locked Rotor Amps	102	123	60	41
Outdoor Fan Motor (1)	Full Load Amps (1 Non-ECM)	1.7	1.7	0.9	0.7
Power Exhaust (1) 0.33 HP	Full Load Amps	2.4	2.4	1.3	1
Service Outlet 115V GFI (amps)		15	15	15	20
Indoor Blower Motor	Horsepower	1.5	1	1	1
	Full Load Amps	11	4.6	2.1	1.7
<sup>2</sup> Maximum Overcurrent Protection (MOCP)	Unit Only	50	30	15	15
	With (1) 0.33 HP Power Exhaust	50	35	---	15
<sup>3</sup> Minimum Circuit Ampacity (MCA)	Unit Only	37	22	11	8
	With (1) 0.33 HP Power Exhaust	40	24	---	9

**ELECTRIC HEAT DATA**

			208	240	208	240	480	600
<sup>2</sup> Maximum Overcurrent Protection (MOCP)	Unit+ Electric Heat	5 kW	70	70	40	45	20	15
		7.5 kW	80	80	45	50	25	20
		10 kW	90	90	50	60	30	20
		15 kW	110	125	70	70	35	30
		22 kW	150	175	80	90	45	35
<sup>3</sup> Minimum Circuit Ampacity (MCA)	Unit+ Electric Heat	5 kW	60	63	35	37	19	14
		7.5 kW	71	77	41	44	23	17
		10 kW	83	90	48	52	26	20
		15 kW	105	116	61	67	34	26
		22 kW	139	155	80	89	45	35
<sup>2</sup> Maximum Overcurrent Protection (MOCP)	Unit+ Electric Heat and (1) 0.33 HP Power Exhaust	5 kW	70	70	45	45	---	15
		7.5 kW	80	90	50	50	---	20
		10 kW	90	100	50	60	---	25
		15 kW	110	125	70	70	---	30
		22 kW	150	175	90	100	---	40
<sup>3</sup> Minimum Circuit Ampacity (MCA)	Unit+ Electric Heat and (1) 0.33 HP Power Exhaust	5 kW	62	66	37	39	---	15
		7.5 kW	74	79	44	47	---	18
		10 kW	85	92	50	54	---	21
		15 kW	108	118	63	69	---	27
		22 kW	141	157	83	92	---	36

NOTE - All units have a minimum Short Circuit Current Rating (SCCR) of 5000 amps.

<sup>1</sup> Extremes of operating range are plus and minus 10% of line voltage.

<sup>2</sup> HACR type breaker or fuse.

<sup>3</sup> Refer to National or Canadian Electrical Code manual to determine wire, fuse and disconnect size requirements.

**ELECTRICAL/ELECTRIC HEAT DATA**
**5 TON**

Model		ZHD060S5			
<sup>1</sup> Voltage - 60Hz		208/230V - 1 Ph	208/230V - 3 Ph	460V - 3 Ph	575 - 3 Ph
Compressor (Non-Inverter)	Rated Load Amps	23.7	16	7.1	6.4
	Locked Rotor Amps	157	156.4	69	47.8
Outdoor Fan Motor (1)	Full Load Amps (1 Non-ECM)	1.7	1.7	0.9	0.7
Power Exhaust (1) 0.33 HP	Full Load Amps	2.4	2.4	1.3	1
Service Outlet 115V GFI (amps)		15	15	15	20
Indoor Blower Motor	Horsepower	1.5	1.5	1.5	1.5
	Full Load Amps	11	6.6	3	2.4
<sup>2</sup> Maximum Overcurrent Protection (MOCP)	Unit Only	60	40	15	15
	With (1) 0.33 HP Power Exhaust	60	45	---	15
<sup>3</sup> Minimum Circuit Ampacity (MCA)	Unit Only	43	29	13	12
	With (1) 0.33 HP Power Exhaust	45	31	---	13

**ELECTRIC HEAT DATA**

			208	240	208	240	480	600
<sup>2</sup> Maximum Overcurrent Protection (MOCP)	Unit+ Electric Heat	5 kW	80	80	50	50	25	20
		7.5 kW	90	90	50	60	25	25
		10 kW	100	100	60	60	30	25
		15 kW	125	125	70	80	40	30
		22 kW	150	175	90	100	50	40
<sup>3</sup> Minimum Circuit Ampacity (MCA)	Unit+ Electric Heat	5 kW	65	69	42	44	21	18
		7.5 kW	77	82	48	51	25	21
		10 kW	88	95	55	59	28	24
		15 kW	111	121	68	74	36	30
		22 kW	144	160	87	96	47	39
<sup>2</sup> Maximum Overcurrent Protection (MOCP)	Unit+ Electric Heat and (1) 0.33 HP Power Exhaust	5 kW	80	80	50	50	---	20
		7.5 kW	90	90	60	60	---	25
		10 kW	100	110	60	70	---	25
		15 kW	125	125	70	80	---	35
		22 kW	150	175	90	100	---	40
<sup>3</sup> Minimum Circuit Ampacity (MCA)	Unit+ Electric Heat and (1) 0.33 HP Power Exhaust	5 kW	68	71	44	46	---	19
		7.5 kW	79	84	51	54	---	22
		10 kW	90	97	57	61	---	25
		15 kW	113	123	70	76	---	31
		22 kW	147	162	90	99	---	40

NOTE - All units have a minimum Short Circuit Current Rating (SCCR) of 5000 amps.

<sup>1</sup> Extremes of operating range are plus and minus 10% of line voltage.

<sup>2</sup> HACR type breaker or fuse.

<sup>3</sup> Refer to National or Canadian Electrical Code manual to determine wire, fuse and disconnect size requirements.

**ELECTRICAL ACCESSORIES**
**DISCONNECTS**
**3 TON | ZHD036S5**

Motor Horsepower	0.75		1		1	1
Electric Heat Voltage	208V-1 Ph	240V-1 Ph	208V-3 Ph	240V-3 Ph	480V-3 Ph	600V-3 Ph
Unit Only	39U71	39U71	39U71	39U71	39U71	39U71
+ Power Exhaust	39U71	39U71	39U71	39U71	39U71	39U71
+ Electric Heat 5 kW to 15 kW	39U71	39U71	39U71	39U71	39U71	39U71
+ Power Exhaust + Electric Heat 5 kW to 15 kW	39U71	39U71	39U71	39U71	---	39U71

**4 TON | ZHD048S5**

Motor Horsepower	1.5		1		1	1
Electric Heat Voltage	208V-1 Ph	240V-1 Ph	208V-3 Ph	240V-3 Ph	480V-3 Ph	600V-3 Ph
Unit Only	39U71	39U71	39U71	39U71	39U71	39U71
+ Power Exhaust	39U71	39U71	39U71	39U71	39U71	39U71
+ Electric Heat 5 kW to 10 kW	39U71	39U71	39U71	39U71	39U71	39U71
+ Electric Heat 15 kW	<sup>1</sup> N/A	39U71	<sup>1</sup> N/A	39U71	39U71	39U71
+ Electric Heat 22.5 kW	<sup>1</sup> N/A	<sup>1</sup> N/A	<sup>1</sup> N/A	<sup>1</sup> N/A	39U71	39U71
+ Power Exhaust + Electric Heat 5 kW to 10 kW	39U71	39U71	39U71	39U71	---	39U71
+ Power Exhaust + Electric Heat 15 kW	<sup>1</sup> N/A	39U71	<sup>1</sup> N/A	39U71	---	39U71
+ Power Exhaust + Electric Heat 22.5 kW	<sup>1</sup> N/A	<sup>1</sup> N/A	<sup>1</sup> N/A	<sup>1</sup> N/A	---	39U71

**5 TON | ZHD060S5**

Motor Horsepower	1.5		1.5		1.5	1.5
Electric Heat Voltage	208V-1 Ph	240V-1 Ph	208V-3 Ph	240V-3 Ph	480V-3 Ph	600V-3 Ph
Unit Only	39U71	39U71	39U71	39U71	39U71	39U71
+ Power Exhaust	39U71	39U71	39U71	39U71	39U71	39U71
+ Electric Heat 5 kW to 10 kW	39U71	39U71	39U71	39U71	39U71	39U71
+ Electric Heat 15 kW	<sup>1</sup> N/A	39U71	<sup>1</sup> N/A	39U71	39U71	39U71
+ Electric Heat 22.5 kW	<sup>1</sup> N/A	<sup>1</sup> N/A	<sup>1</sup> N/A	<sup>1</sup> N/A	39U71	39U71
+ Power Exhaust + Electric Heat 5 kW to 10 kW	39U71	39U71	39U71	39U71	---	39U71
+ Power Exhaust + Electric Heat 15 kW	<sup>1</sup> N/A	39U71	<sup>1</sup> N/A	39U71	---	39U71
+ Power Exhaust + Electric Heat 22.5 kW	<sup>1</sup> N/A	<sup>1</sup> N/A	<sup>1</sup> N/A	<sup>1</sup> N/A	---	39U71

Disconnect - 39U71 - 80A (Tall Cabinet)

<sup>1</sup> Disconnect must be field furnished.

**ELECTRICAL ACCESSORIES**
**FUSE BLOCKS**
**3 TON | ZHD036S5**

Motor Horsepower	0.75		1		1	1
Electric Heat Voltage	208V-1 Ph	240V-1 Ph	208V-3 Ph	240V-3 Ph	480V-3 Ph	600V-3 Ph
Unit Only	10A26	10A26	10A27	10A27	10A29	10A29
Unit + Power Exhaust	10A26	10A26	10A27	10A27	---	10A29

**4 TON | ZHD048S5**

Motor Horsepower	1.5		1		1	1
Electric Heat Voltage	208V-1 Ph	240V-1 Ph	208V-3 Ph	240V-3 Ph	480V-3 Ph	600V-3 Ph
Unit Only	10A26	10A26	10A27	10A27	10A29	10A29
Unit + Power Exhaust	10A26	10A26	10A27	10A27	---	10A29

**5 TON | ZHD060S5**

Motor Horsepower	1.5		1.5		1.5	1.5
Electric Heat Voltage	208V-1 Ph	240V-1 Ph	208V-3 Ph	240V-3 Ph	480V-3 Ph	600V-3 Ph
Unit Only	10A26	10A26	10A28	10A28	10A29	10A29
Unit + Power Exhaust	10A26	10A26	10A28	10A28	---	10A29

## ELECTRIC HEAT CAPACITIES

Input Voltage	5 kW			7.5 kW			10 kW		
	No of Stages	kW input	Btuh Output	No of Stages	kW input	Btuh Output	No of Stages	kW input	Btuh Output
208	1	3.8	12,800	1	5.6	19,200	1	7.5	25,600
220	1	4.2	14,300	1	6.3	21,500	1	8.4	28,700
230	1	4.6	15,700	1	6.9	23,500	1	9.2	31,400
240	1	5.0	17,100	1	7.5	25,600	1	10.0	34,200
440	1	4.2	14,300	1	6.3	21,500	1	8.4	28,700
460	1	4.6	15,700	1	6.9	23,500	1	9.2	31,400
480	1	5.0	17,100	1	7.5	25,600	1	10.0	34,200
550	1	4.2	14,300	1	6.3	21,500	1	8.4	28,700
575	1	4.6	15,700	1	6.9	23,500	1	9.2	31,400
600	1	5.0	17,100	1	7.5	25,600	1	10.0	34,200
Input Voltage	15 kW			22.5 kW					
	No of Stages	kW input	Btuh Output	No of Stages	kW input	Btuh Output			
208	1	11.2	38,400	1	16.9	57,700			
220	1	12.6	43,000	1	18.9	64,500			
230	1	13.8	47,000	1	20.7	70,700			
240	1	15.0	51,200	1	22.5	76,800			
440	1	12.6	43,000	1	18.9	64,500			
460	1	13.8	47,000	1	20.7	70,700			
480	1	15.0	51,200	1	22.5	76,800			
550	1	12.6	43,000	1	18.9	64,500			
575	1	13.8	47,000	1	20.7	70,700			
600	1	15.0	51,200	1	22.5	76,800			

### FIELD WIRING NOTES

- For use with copper wiring only
- Field wiring not furnished
- All wiring must conform to NEC or CEC and local electrical codes
- For specific wiring information, please refer to the installation instructions

## OUTDOOR SOUND DATA

Size	Octave Band Sound Power Levels dBA, re 10 <sup>-12</sup> Watts - Center Frequency - Hz							1 Sound Rating Number dBA
	125	250	500	1000	2000	4000	8000	
036	66	70	75	73	71	67	60	79
048	62	69	73	72	69	65	57	78
060	70	72	78	75	72	70	66	82

<sup>1</sup> Sound Rating Number according to AHRI Standard 270-2008. Sound Rating Number is the overall A-Weighted Sound Power Level, (LWA), dB (100 Hz to 10,000 Hz).

# UNIT CLEARANCES

## UNIT WITH DOWNFLOW ECONOMIZER

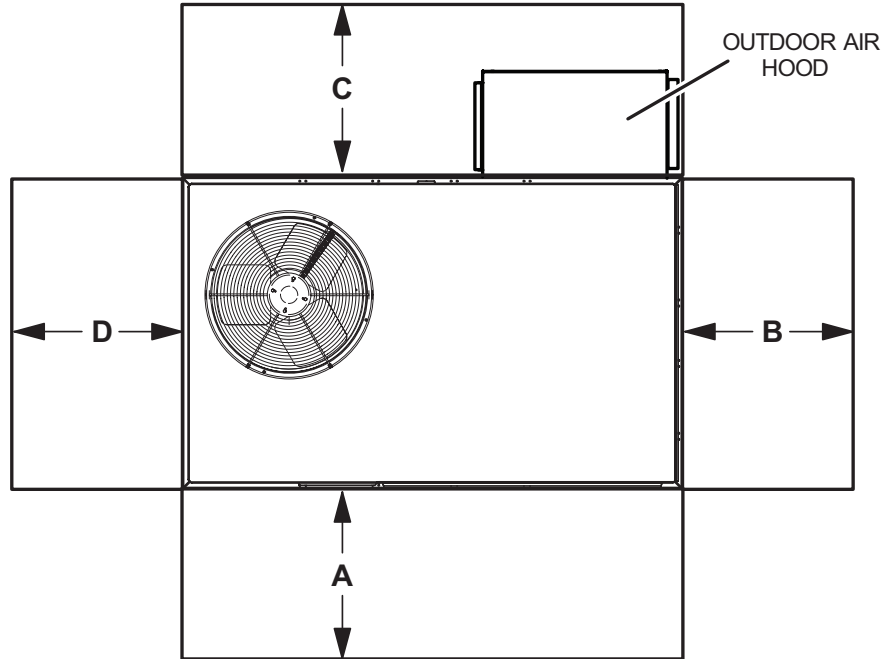

## UNIT WITH HORIZONTAL ECONOMIZER

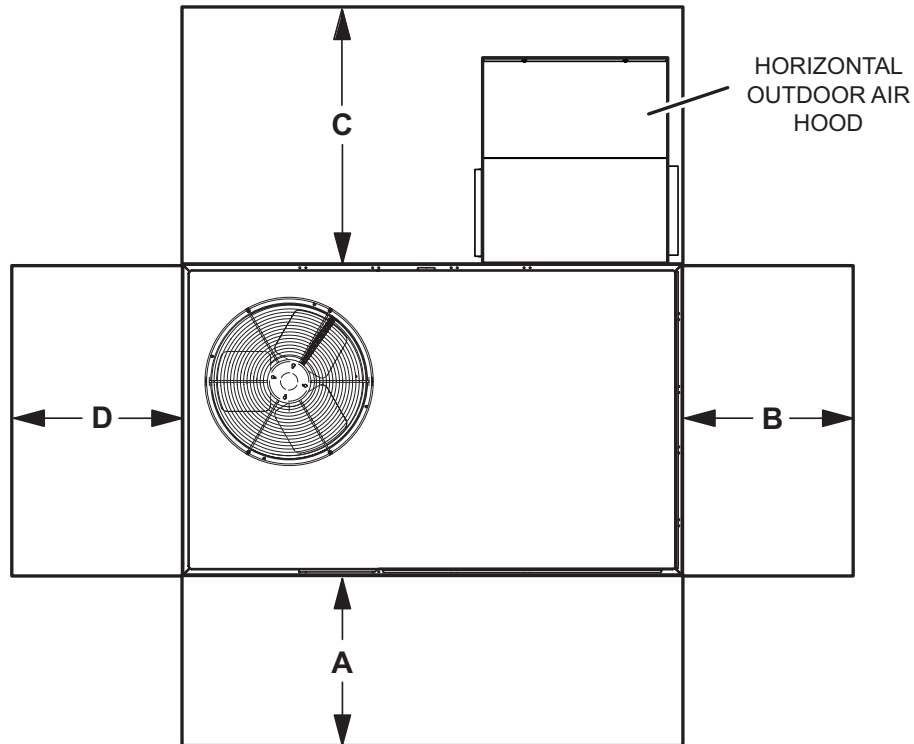

1 Unit Clearance	A		B		C Downflow		C Horizontal		D		Top Clearance
	in.	mm	in.	mm	in.	mm	in.	mm	in.	mm	
<b>Service Clearance</b>	36	914	36	914	36	914	60	1524	36	914	<b>Unobstructed</b>
<b>Minimum Operation Clearance</b>	36	914	36	914	36	914	60	1524	36	914	

NOTE - Entire perimeter of unit base requires support when elevated above the mounting surface.

<sup>1</sup> **Service Clearance** - Required for removal of serviceable parts.

**Minimum Operation Clearance** - Required clearance for proper unit operation.

## WEIGHT DATA

Model	Net				Shipping			
	Base		Max.		Base		Max.	
	lbs.	kg	lbs.	kg	lbs.	kg	lbs.	kg
ZHD036S	580	263	634	288	585	265	639	290
ZHD048S	585	265	639	290	590	268	644	292
ZHD060S	610	277	664	301	615	279	669	303

Base Unit - The unit with NO OPTIONS.

Max. Unit - The unit with ALL OPTIONS Installed. (Economizer, etc.)

## FACTORY / FIELD INSTALLED OPTIONS AND ACCESSORIES - NET WEIGHTS

Description	lbs.	kg	
<b>ECONOMIZER / OUTDOOR AIR / POWER EXHAUST</b>			
<b>Economizer</b>			
Downflow	75	34	
Horizontal	102	46	
<b>Outdoor Air Dampers</b>			
Motorized	39	18	
Manual	29	13	
<b>Power Exhaust</b>			
Downflow	54	24	
Horizontal	41	19	
<b>ELECTRIC HEAT</b>			
5 kW	25	11	
7.5 kW	26	12	
10 kW	27	12	
15 kW	27	12	
22.5 kW	29	13	
<b>COIL/HAIL GUARDS</b>			
All models	50	23	
<b>ROOF CURBS</b>			
<b>Hybrid Roof Curbs, Downflow</b>			
8 in. height	63	29	
14 in. height	83	38	
18 in. height	93	42	
24 in. height	113	51	
<b>CEILING DIFFUSERS</b>			
Step-Down	RTD9-65S	80	36
Flush	FD9-65S	80	36

# DIMENSIONS

# UNIT

Size	CORNER WEIGHTS																CENTER OF GRAVITY							
	AA		BB				CC				DD				EE				FF					
	Base		Max.		Base		Max.		Base		Max.		Base		Max.		Base		Max.		Base		Max.	
	lbs.	kg	lbs.	kg	lbs.	kg	lbs.	kg	lbs.	kg	lbs.	kg	lbs.	kg	in.	mm	in.	mm	in.	mm	in.	mm	in.	mm
036	158	72	173	78	133	60	145	66	124	56	135	61	147	67	160	73	41.25	1048	39.25	997	24.5	622	25.75	654
048	168	76	183	83	136	62	148	67	120	54	130	59	148	67	161	73	42	1067	40	1016	25	635	26.5	673
060	163	74	177	80	142	64	155	70	142	64	155	70	163	74	177	80	40.5	1029	38.5	978	23.5	597	25	635

Base Unit - The unit with NO OPTIONS.

Max. Unit - The unit with ALL OPTIONS Installed. (Economizer, largest blower motor, etc.).

### FIELD WIRING NOTES

- For use with copper wiring only
- Field wiring not furnished
- All wiring must conform to NEC or CEC and local electrical codes
- For specific wiring information, please refer to the installation instructions

### BOTTOM POWER ENTRY

Holes required for Optional Bottom Power Entry Kit

	Threaded Conduit Fittings (Provided in Kit)	Wire Use	Hole Diameter Required in Unit Base (Max.)
<b>E</b>	1/2	ACC	7/8 (23)
<b>F</b>	1/2	24V	7/8 (23)
<b>G</b>	3/4	POWER	1-1/8 (29)

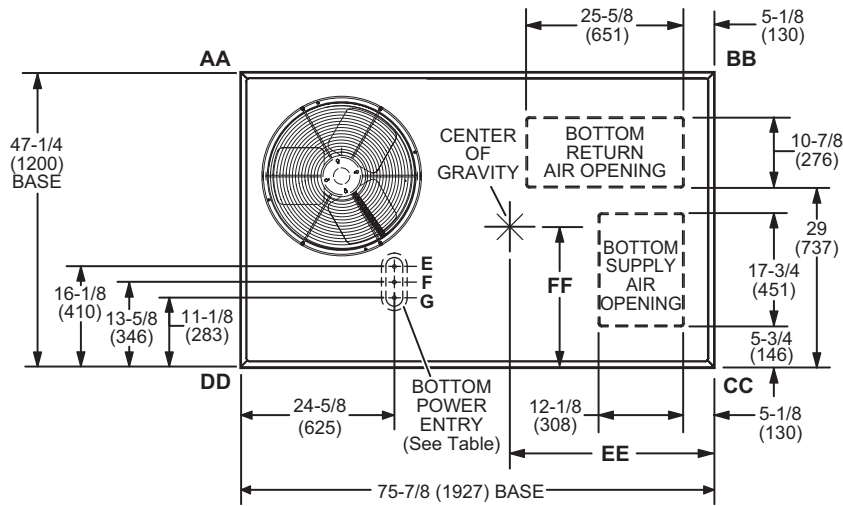

**TOP VIEW (Base)**

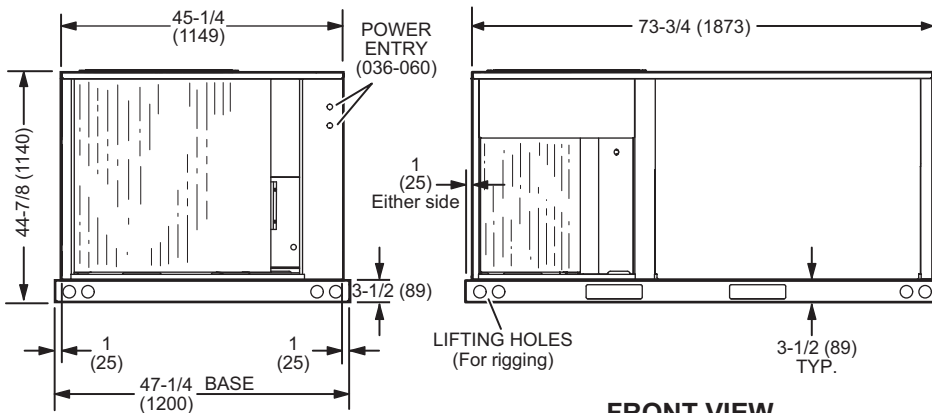

**END VIEW**

**FRONT VIEW**

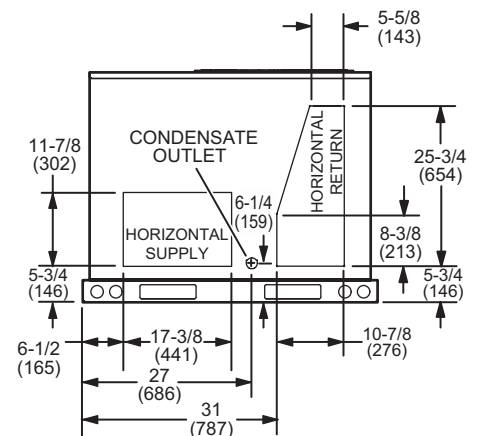

**END VIEW**

**OUTDOOR AIR HOOD DETAIL FOR OPTIONAL ECONOMIZER  
(Downflow Applications)**

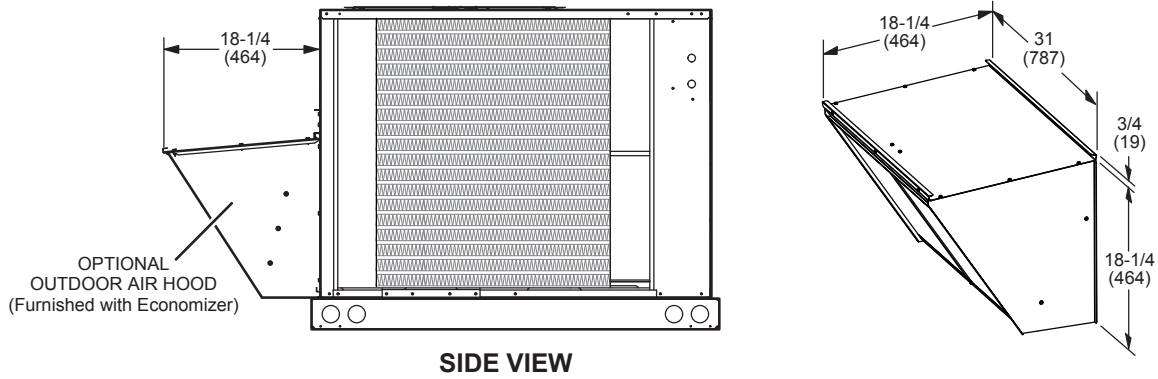

**OUTDOOR AIR DAMPER HOOD DETAIL (Downflow or Horizontal Applications)**

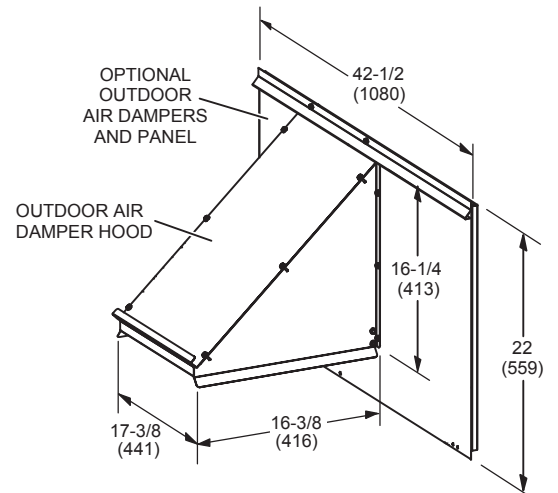
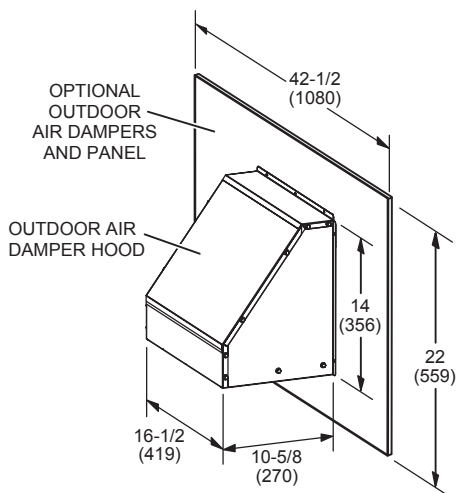
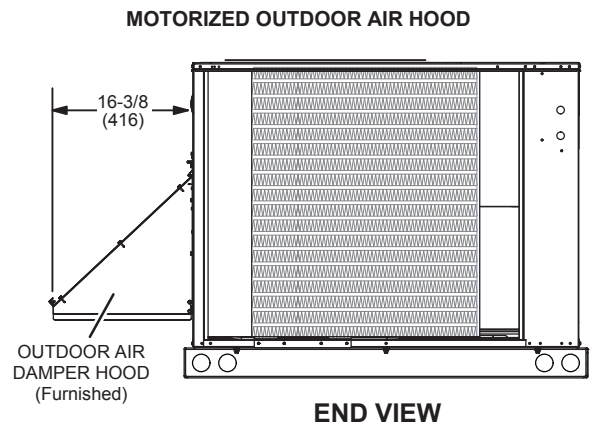
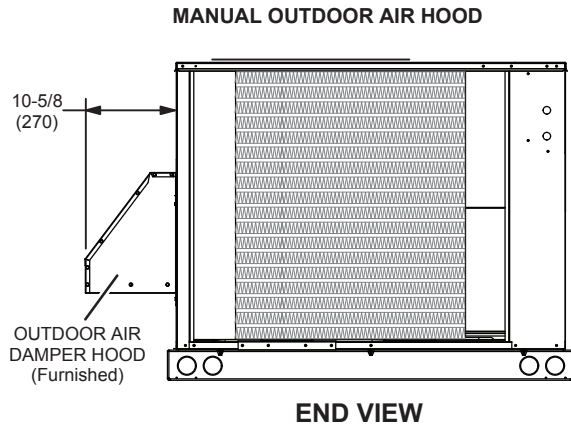

**DIMENSIONS - ACCESSORIES**

**OUTDOOR AIR HOOD DETAIL WITH OPTIONAL ECONOMIZER AND BAROMETRIC RELIEF DAMPERS  
(Horizontal Applications)**

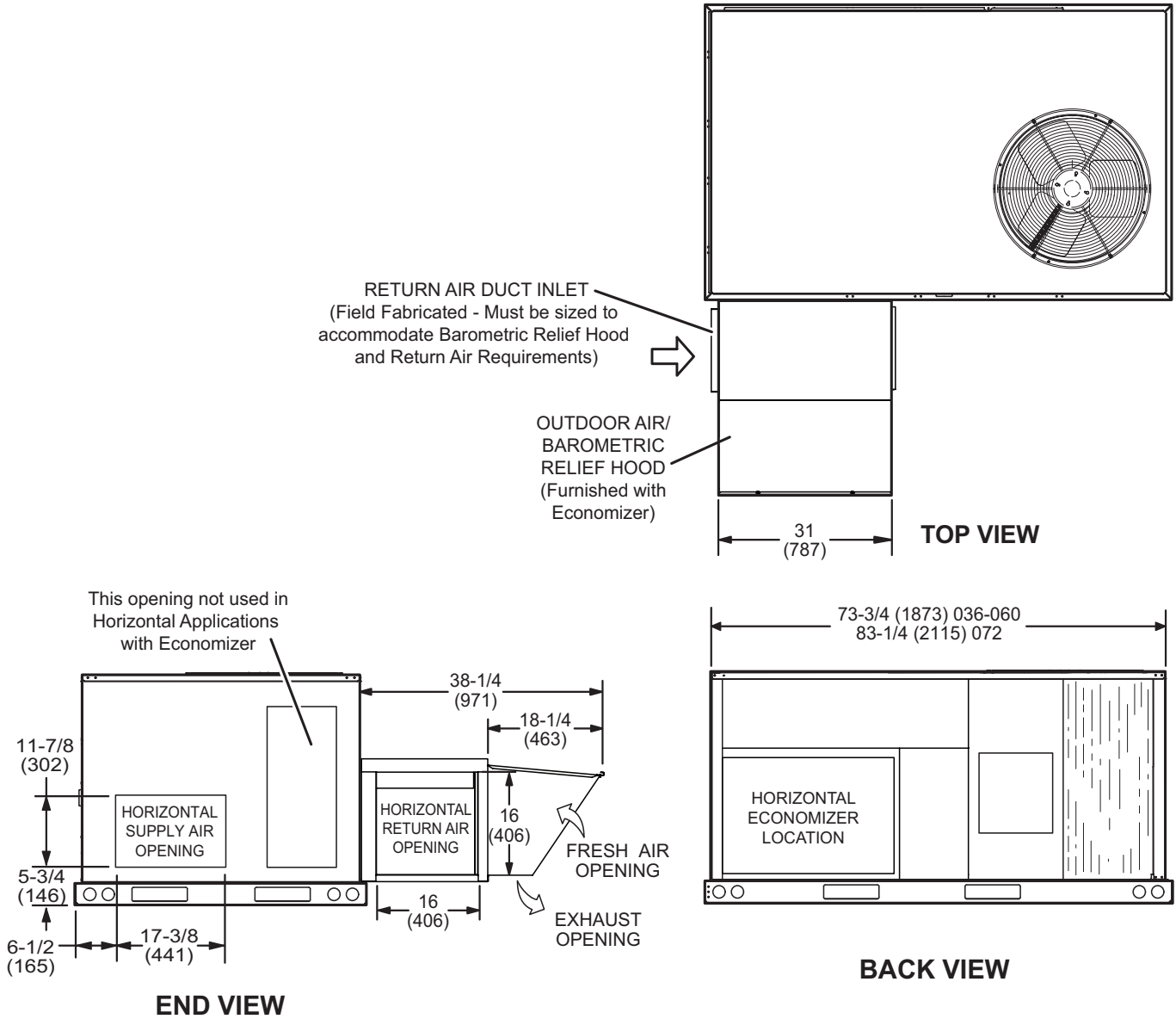

Note - Return Air Duct and Transition must be supported.

# DIMENSIONS - ACCESSORIES

## HYBRID ROOF CURBS - DOUBLE DUCT OPENING

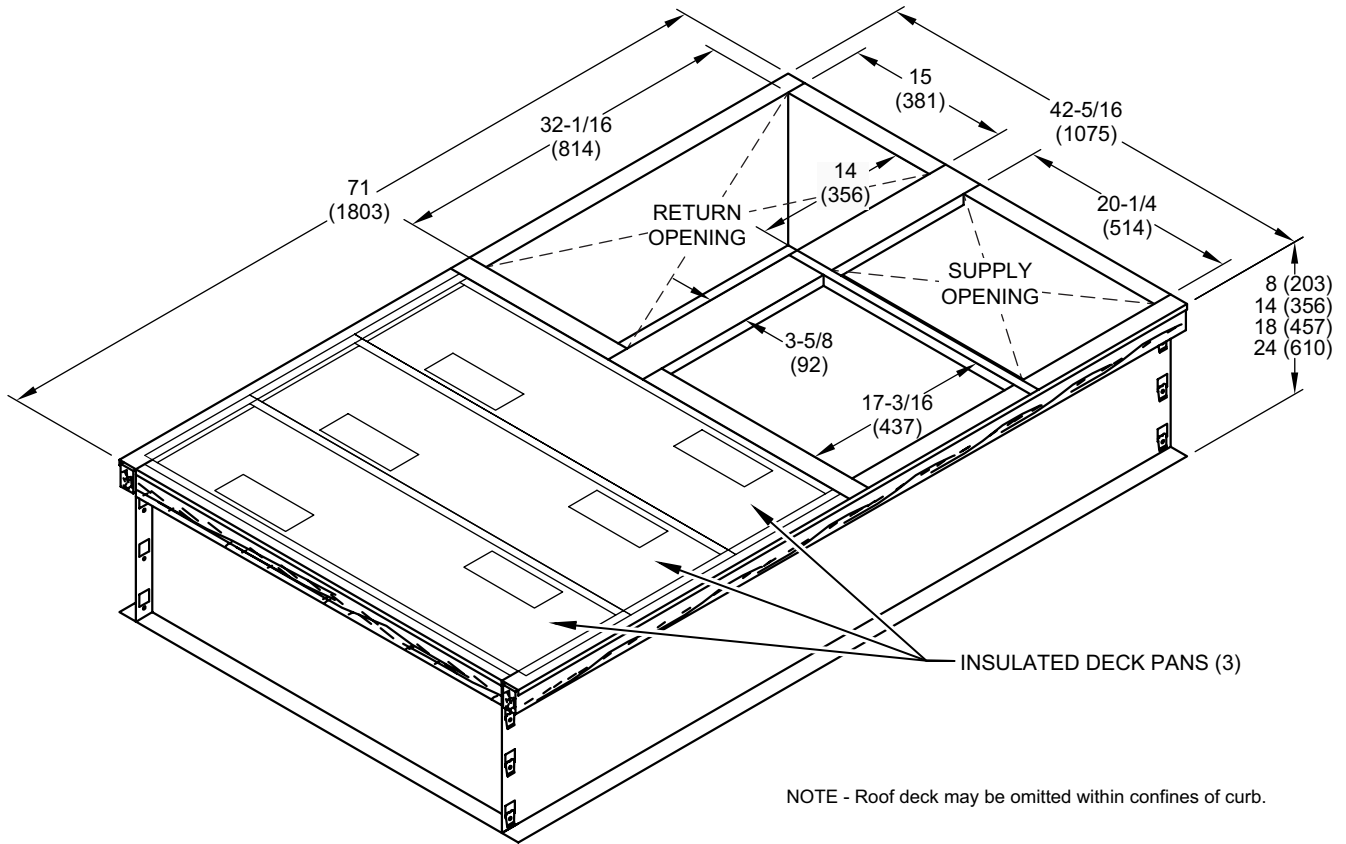

### TYPICAL FLASHING DETAIL FOR ROOF CURB

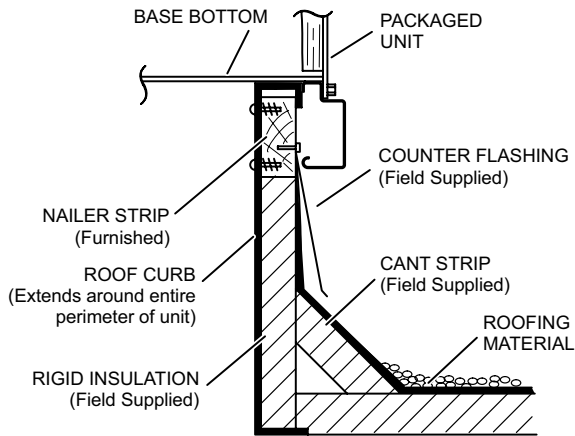

### DETAIL ROOF CURB

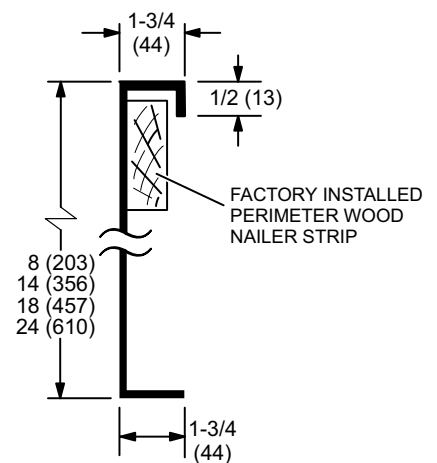

## DIMENSIONS - ACCESSORIES

### COMBINATION CEILING SUPPLY AND RETURN DIFFUSERS

#### STEP-DOWN CEILING DIFFUSER

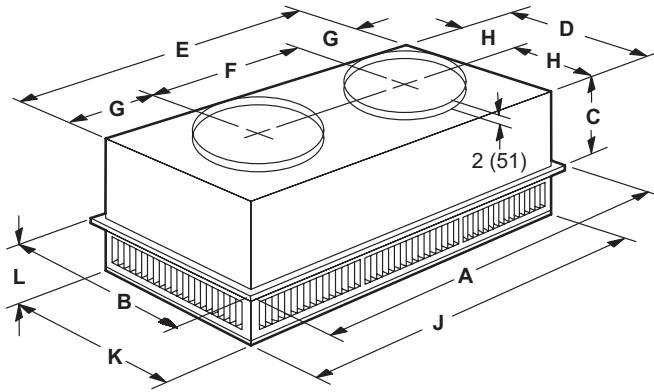

#### FLUSH CEILING DIFFUSER

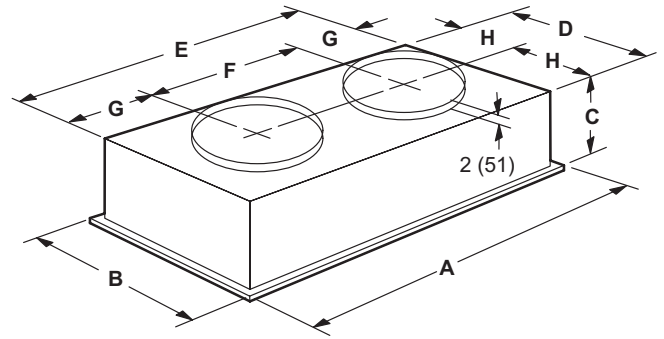

Model Number		RTD9-65S
A	in.	47-5/8
	mm	1159
B	in.	23-5/8
	mm	600
C	in.	11-3/8
	mm	289
D	in.	21-1/2
	mm	546
E	in.	45-1/2
	mm	1156
F	in.	22-1/2
	mm	572
G	in.	11-1/2
	mm	292
H	in.	10-3/4
	mm	273
J	in.	45-1/2
	mm	1156
K	in.	21-1/2
	mm	546
L	in.	7-1/8
	mm	181
Duct Size	in.	18 round
	mm	457 round

Model Number		FD9-65S
A	in.	47-5/8
	mm	1159
B	in.	23-5/8
	mm	600
C	in.	13-1/2
	mm	343
D	in.	21
	mm	533
E	in.	45
	mm	1143
F	in.	22-1/2
	mm	572
G	in.	11-1/4
	mm	286
H	in.	10-1/2
	mm	267
Duct Size	in.	18 round
	mm	457 round

## REVISIONS

Sections	Description of Change
Options / Accessories	Added Smoke Detectors, GFI Outlets, and Disconnects as options.
Electrical Accessories - Disconnects	New Section.
Electrical Accessories - Fuse Blocks	New Section.



Visit us at [www.Lennox.com](http://www.Lennox.com)

For the latest technical information, [www.LennoxCommercial.com](http://www.LennoxCommercial.com)

Contact us at 1-800-4-LENNOX

NOTE - Due to Lennox' ongoing commitment to quality, Specifications, Ratings and Dimensions subject to change without notice and without incurring liability. Improper installation, adjustment, alteration, service or maintenance can cause property damage or personal injury. Installation and service must be performed by a qualified installer and servicing agency.

©2026 Lennox Industries, Inc.