

UNIT INFORMATION

SCH SERIES 10 & 20 Ton

100115
04/2026

Service Literature

SCH120 & 240 With R-454B

The SCH120 & 240 units are configured to order units (CTO) with a wide selection of factory installed options. Cooling capacities range from 120,000 to 228,000 Btuh. SGH120 utilizes two compressors and two condenser fans. SGH240 utilizes four compressors and six condenser fans.

Optional electric heat is factory installed. Electric heat operates in single or multiple stages depending on the kW input size. 15kW to 60 kW heat sections are available for the SCH120 units and 20kW to 90kW heat sections are available for the SCH240.

Both models are equipped with Multi-Stage Air Volume MSAV® blower. The VFD-driven blower will operate at lower speeds when demand is low and increase to higher speeds when demand is high.

False ceilings or drop ceiling may be used as a return air plenum only if the unit being installed has a Refrigerant Detection System installed.

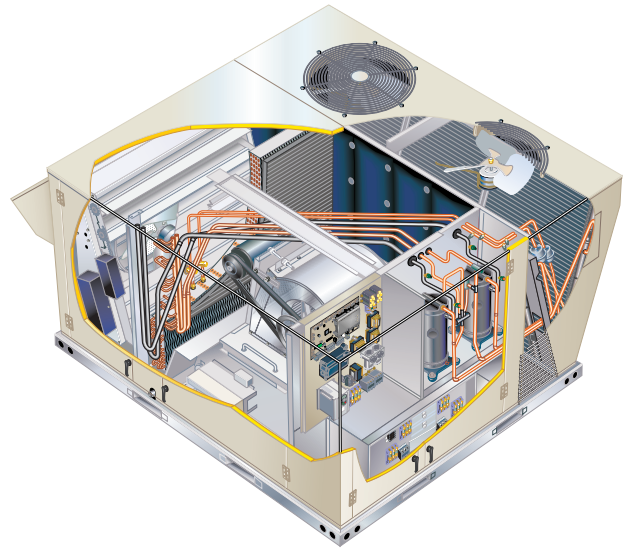

All maintenance staff and others working in the local area shall be instructed on the nature of work being carried out with work in confined spaces being avoided.

Ensure that the area is in the open or that it is adequately ventilated before breaking into the system or conducting any hot work. A degree of ventilation shall continue during the period that the work is carried out. The ventilation should safely disperse any released refrigerant and preferably expel it externally into the atmosphere.

Table of Contents

Options / Accessories	Page 3
Specifications	Page 5
Blower Data	Page 6
Electrical Data	Page 9
Unit Parts Arrangement	Page 13
I-Unit Components	Page 14
RDS Sensors.	Page 24
II-Charging.	Page 32
III-Start Up - Operation	Page 42
IV-System Service Checks	Page 43
V-Maintenance	Page 43
VI-Accessories	Page 46
VII-MSAV Start Up	Page 55
VIII -Decommissioning	Page 58
IX-Wiring and Operation Sequence	Page 59

⚠ WARNING

Do not use means to accelerate the defrosting process or to clean, other than those recommended by the manufacturer.

The appliance shall be stored in a room without continuously operating ignition sources (for example: open flames, an operating gas appliance, or an operating electric heater).

Do not pierce or burn.

Be aware that refrigerants may not contain an odor.

⚠ WARNING

If this appliance is conditioning a space with an area smaller than TA min or stored in a space with an area smaller than A min as defined by this instruction, then that space must be without continuously operating open flames (e.g. an operating gas appliance) or other potential ignition sources (e.g. an operating electric heater or similar hot surface). A flame-producing device may be installed in the same space if the device is provided with an effective flame arrest system.

⚠ WARNING

Auxiliary devices which may be potential ignition sources shall not be installed in the duct work. Examples of potential ignition sources are hot surfaces with a temperature exceeding 700°C and electric switching components.

⚠ WARNING

To prevent serious injury or death:

- 1- Lock-out/tag-out before performing maintenance.
- 2- If system power is required (e.g., smoke detector maintenance), disable power to blower, remove fan belt where applicable, and ensure all controllers and thermostats are set to the "OFF" position before performing maintenance.
- 3- Always keep hands, hair, clothing, jewelry, tools, etc., away from moving parts.

⚠ WARNING

Only Manufacturer approved auxiliary devices are permitted to be installed in this unit.

⚠ CAUTION

Any service personnel installing, decommissioning, or performing maintenance on the unit must be properly trained with A2L refrigerants.

⚠ WARNING



Electric shock hazard. Can cause injury or death. Before attempting to perform any service or maintenance, turn the electrical power to unit OFF at disconnect switch(es). Unit may have multiple power supplies.

⚠ WARNING

Improper installation, adjustment, alteration, service or maintenance can cause property damage, personal injury or loss of life. Installation and service must be performed by a licensed professional HVAC installer or equivalent, service agency, or the gas supplier.

⚠ CAUTION

As with any mechanical equipment, contact with sharp sheet metal edges can result in personal injury. Take care while handling this equipment and wear gloves and protective clothing.

⚠ IMPORTANT

The Clean Air Act of 1990 bans the intentional venting of refrigerant (CFC's and HCFC's) as of July 1, 1992. Approved methods of recovery, recycling or reclaiming must be followed. Fines and/or incarceration may be levied for non-compliance.

⚠ WARNING

- This appliance must be installed in accordance with local and national wiring regulations.
- If the appliance is not fitted with an option for full disconnection from power, a means of disconnection must be incorporated in the fixed wiring in accordance with national and local wiring regulations.

⚠ CAUTION

Servicing shall be performed only as recommended by the manufacturer.

⚠ CAUTION

Leak Detection System installed. Unit must be powered except for service.

⚠ WARNING

Ducts connected to an appliance shall not contain a potential ignition source.

⚠ IMPORTANT

Pipe work, including piping material, pipe routing, and installation shall include protection from physical damage in operation and service, and be in compliance with national and local codes and standards, such as ASHRAE 15, ASHRAE 15.2, IAPMO Uniform Mechanical Code, ICC International Mechanical Code, or CSA B52. All field joints shall be accessible for inspection prior to being covered or enclosed.

⚠ IMPORTANT

Refrigerant sensors for refrigerant detection systems shall only be replaced with sensors specified by the appliance manufacture.

⚠ CAUTION

This unit is equipped with electrically powered safety measures. To be effective, the unit must be electrically powered at all times after installation, other than when servicing.

OPTIONS / ACCESSORIES

Item Description		Order Number	120	240
COOLING SYSTEM				
Corrosion Protection	Coated indoor/outdoor coil assemblies, painted cabinet interior	Factory	O	O
	Coated outdoor coil assembly	Factory	O	O
Drain Pan Overflow Switch		21Z07	OX	OX
BLOWER - SUPPLY AIR				
ECM DirectPlus™, Direct Drive, MSAV® (Multi-Stage Air Volume)	1.5 hp	Factory		
Belt Drive, MSAV® (Multi-Stage Air Volume)	3 hp	Factory	O	
	5 hp	Factory		O
	7.5 hp	Factory		O
CABINET				
Combination Coil/Hail Guards		19H54		
		19H55	X	
		13T16		X
CONTROLS				
Commercial Controls	LonTalk® Module	Factory	O	O
Dirty Filter Switch		Factory	O	O
Smoke Detectors	Supply or Return (Power board and one sensor)	10B40		
		10B42	OX	OX
	Supply and Return (Power board and two sensors)	10B41		
		10B43	OX	OX
ELECTRICAL				
Voltage 60 Hz	460V - 3 phase	Factory	O	O
	575V - 3 phase	Factory	O	O
GFI Service Outlets (REQUIRED)	20 amp non-powered, field-wired (all voltages)	Factory	O	O
Weatherproof Cover for GFI		10C89	X	X
ELECTRIC HEAT				
10 kW	460V-3ph	Factory		
15 kW	460V or 575V-3ph	Factory	O	
20 kW	460V-3ph	Factory	O	
30 kW	460V or 575V-3ph	Factory	O	O
40 kW	460V or 575V-3ph	Factory		O
45 kW	460V or 575V-3ph	Factory	O	
60 kW	460V or 575V-3ph	Factory	O	O
90 kW	460V or 575V-3ph	Factory		O
HUMIDITROL® CONDENSER REHEAT OPTION				
Humiditrol® Dehumidification Option		Factory	O	O

NOTE - Order numbers shown are for ordering field installed accessories.
OX - Configure To Order (Factory Installed) or Field Installed
O = Configure To Order (Factory Installed)
X = Field Installed

OPTIONS / ACCESSORIES

Item Description	Order Number	120	240
INDOOR AIR QUALITY			
Air Filters			
Standard Air Filters	MERV 8 (16 x 20 x 2 - Order 4 per unit)	54W20	
	MERV 8 (20 x 25 x 2 - Order 4 per unit)	50W61	OX
	MERV 8 (20 x 20 x 2 - Order 12 per unit)	54W21	OX
Healthy Climate® High Efficiency Air Filters	MERV 13 (16 x 20 x 2 - Order 4 per unit)	52W37	
	MERV 13 (20 x 25 x 2 - Order 4 per unit)	52W41	OX
	MERV 13 (20 x 20 x 2 - Order 12 per unit)	52W39	OX
Replacement Media Filter With Metal Mesh Frame 20 x 20 x 2 Order 12 per unit (includes non-pleated filter media)	44N60		X
Indoor Air Quality (CO₂) Sensors			
Sensor - Wall-mount, off-white plastic cover with LCD display	77N39	X	X
Sensor - Wall-mount, off-white plastic cover, no display	23V86	X	X
Sensor - Black plastic case, LCD display, rated for plenum mounting	87N52	X	X
Sensor - Black plastic case, no display, rated for plenum mounting	23V87	X	X
CO ₂ Sensor Duct Mounting Kit - for downflow applications	23Y47	X	X
Aspiration Box - for duct mounting non-plenum rated CO ₂ sensors (77N39)	90N43	X	X
ECONOMIZER			
High Performance Economizer (Approved for California Title 24 Building Standards / AMCA Class 1A Certified)			
ULL Performance Economizer - Includes Outdoor Air Hood (Global Sensor, field provided, order Barometric Relief Dampers separately)	Factory 18X87	O	OX
Economizer Controls			
Differential Enthalpy (Not for Title 24)	Order 2 21Z09	OX	OX
Global Control	Sensor Field Provided Factory	O	O
Barometric Relief Dampers			
Barometric Relief Dampers (No Hood)	Factory		
Barometric Relief Dampers With Power Exhaust Fans (Hood Furnished)	Factory	O	
Barometric Relief Dampers Without Power Exhaust Fans (No Hood)	Factory	O	
Barometric Relief Dampers Without Power Exhaust Fans (Hood Furnished)	Factory		O
POWER EXHAUST			
Standard Static	Factory	O	O
OUTDOOR AIR			
Motorized Outdoor Air Dampers with Outdoor Air Hood and Bird Screen	18X89		X
Manual Outdoor Air Damper with Outdoor Air Hood and Bird Screen	18X88		X
ROOF CURBS			
Hybrid Roof Curbs, Downflow, 14 in. height	11F70		
	11F72	X	
	Full Perimeter 11F74		X
Hybrid Roof Curbs, Downflow 24 in. height	11F71		
	11F73	X	
	Full Perimeter 11F75		X
Curb Alignment (See note in the Roof Curb section)	Factory		O

NOTE - Order numbers shown are for ordering field installed accessories.

OX - Configure To Order (Factory Installed) or Field Installed

O = Configure To Order (Factory Installed)

X = Field Installed

SPECIFICATIONS		BELT DRIVE 10 - 20 TON				
Model		SCH120H5M		SCH240H5M		
Nominal Tonnage		10		20		
Efficiency Type		High		High		
Blower Type		MSAV® (Multi-Stage Air Volume) (Belt Drive)		MSAV® (Multi-Stage Air Volume) (Belt Drive)		
Cooling Performance	Gross Cooling Capacity - Btuh	123,500		234,000		
	¹ Net Cooling Capacity - Btuh	120,000		228,000		
	AHRI Rated Air Flow - cfm	3800		7100		
	Total Unit Power	10		18.8		
	¹ IEER (Btuh/Watt)	15.6		17.0		
	¹ EER (Btuh/Watt)	12.0		12.2		
Refrigerant Charge	Refrigerant Type		R-454B			
	Without Reheat Option	Circuit 1	7 lbs. 0 oz.		6 lbs. 11 oz.	
		Circuit 2	4 lbs. 3 oz.		6 lbs. 1 oz.	
		Circuit 3	---		5 lbs. 1 oz.	
		Circuit 4	---		5 lbs. 3 oz.	
	With Reheat Option	Circuit 1	7 lbs. 0 oz.		7 lbs. 12 oz.	
		Circuit 2	5 lbs. 2 oz.		7 lbs. 3 oz.	
		Circuit 3	---		5 lbs. 5 oz.	
		Circuit 4	---		5 lbs. 6 oz.	
	² Sound Rating Number	dBa	89		92	
Electric Heat Options Available		(See page 3)				
Compressor Type (Number)		Two-Stage Scroll (1) Single-Stage Scroll (1)		Single-Stage Scroll (4)		
Condenser Coil	Net face area - ft. ²		45.7		68.3	
	Rows		1		1	
	Fins - in.		23		23	
Condenser Fan(s)	Motor (number) HP (type)		(2) 1/2 (PSC)		(6) 1/3 (PSC)	
	Rpm		1075		1075	
	Watts		1160		1900	
	Diameter (Number) - in.		(2) 24		(6) 24	
	Blades		4		3	
	Total air volume - Cfm		10,000		22,500	
	Evaporator Coil	Net face area - ft. ²		13.54		32.2
Tube diameter - in.		3/8		3/8		
Number of rows		4		3		
Fins per inch		14		14		
Condensate drain size (NPT) - in.		(1) 1		(1) 1		
Expansion device type		Balance Port TXV, removable head				
³ Indoor Blower	Nominal motor HP		3		5	7.5
	RPM Range (Standard Static)		Drive #3 - 660-900 rpm		Drive #4 - 520-685 rpm	Drive #7 - 770-965 rpm
	RPM Range (High Static)		Drive #4 - 865-1080 rpm		Drive #5 - 685-865 rpm	---
	Wheel nominal diameter x width - in.		(1) 15 x 15		(2) 18 x 15	(2) 18 x 15
Filters	Type of filter		MERV 8 or 13			
	Number and size - in.		(4) 20 x 25 x 2		(12) 20 x 20 x 2	
Line voltage data (Volts-Phase-Hz)		460-3-60, 575-3-60				

NOTE - Net capacity includes evaporator blower motor heat deduction. Gross capacity does not include evaporator blower motor heat deduction.

¹ AHRI Certified to AHRI Standard 340/360: 95°F outdoor air temperature and 80°F db/67°F wb entering evaporator air; minimum external duct static pressure..

² Sound Rating Number rated in accordance with test conditions included in AHRI Standard 270-95.

³ Using total air volume and system static pressure requirements determine from blower performance tables rpm and motor output required. Maximum usable output of motors furnished are shown. In Canada, nominal motor output is also maximum usable motor output. If motors of comparable output are used, be sure to keep within the service factor limitations outlined on the motor nameplate.

NOTE – Units equipped with MSAV® (Multi-Stage Air Volume) are limited to a motor service factor of 1.0.

BLOWER DATA

BELT DRIVE | 10 TON

SCH120H5M BLOWER PERFORMANCE

NOTE - Blower Table Includes Resistance For Base Unit With Electric Heat, Wet Indoor Coil And Air Filters In Place.

NOTE - MINIMUM AIR VOLUME REQUIRED FOR USE WITH OPTIONAL ELECTRIC HEAT - 3800 CFM.

See Blower Motor / Drive Kit Table on page 8 for Motor HP and Drive Kit RPM Ranges Available.

Air Volume cfm	EXTERNAL STATIC PRESSURE - In. w.g.																									
	0.1		0.2		0.3		0.4		0.5		0.6		0.7		0.8		0.9		1.0		1.1		1.2		1.3	
	RPM	BHP	RPM	BHP	RPM	BHP	RPM	BHP	RPM	BHP	RPM	BHP	RPM	BHP	RPM	BHP	RPM	BHP	RPM	BHP	RPM	BHP	RPM	BHP	RPM	BHP
2000	418	0.26	453	0.33	490	0.41	530	0.48	573	0.55	617	0.62	658	0.68	697	0.76	734	0.84	767	0.93	797	1.01	825	1.09	852	1.17
2200	430	0.34	465	0.42	502	0.49	543	0.56	586	0.63	630	0.70	671	0.78	709	0.86	745	0.95	778	1.04	807	1.12	835	1.21	863	1.29
2400	444	0.44	478	0.50	516	0.57	557	0.65	601	0.72	644	0.80	683	0.88	721	0.97	757	1.07	789	1.16	818	1.25	847	1.33	875	1.41
2600	458	0.53	493	0.60	530	0.67	572	0.74	616	0.82	658	0.91	697	1.00	734	1.09	769	1.19	801	1.29	830	1.38	859	1.46	888	1.55
2800	473	0.63	508	0.70	547	0.77	589	0.85	632	0.93	673	1.03	711	1.13	747	1.23	781	1.33	813	1.43	843	1.52	872	1.60	902	1.69
3000	489	0.74	525	0.81	564	0.89	607	0.97	649	1.06	688	1.16	725	1.27	761	1.38	795	1.48	826	1.58	857	1.66	887	1.75	918	1.84
3200	506	0.86	543	0.93	583	1.01	625	1.10	666	1.20	703	1.31	740	1.42	775	1.53	809	1.64	841	1.73	871	1.82	902	1.91	934	2.01
3400	525	0.99	563	1.07	603	1.15	644	1.24	682	1.36	719	1.48	755	1.59	790	1.70	824	1.80	856	1.90	887	1.99	919	2.08	951	2.18
3600	545	1.13	583	1.21	623	1.30	662	1.41	699	1.53	735	1.65	771	1.77	806	1.87	840	1.97	872	2.07	903	2.16	936	2.25	969	2.36
3800	566	1.28	604	1.36	643	1.46	679	1.58	715	1.71	752	1.84	788	1.95	823	2.06	856	2.16	889	2.25	921	2.34	954	2.43	987	2.54
4000	587	1.44	625	1.53	661	1.64	697	1.78	733	1.91	770	2.03	806	2.15	841	2.25	874	2.34	906	2.43	938	2.52	971	2.61	1005	2.71
4200	609	1.60	645	1.71	680	1.85	715	1.99	751	2.12	788	2.24	825	2.35	859	2.44	892	2.53	924	2.62	957	2.71	989	2.80	1023	2.89
4400	629	1.79	664	1.92	698	2.07	734	2.21	771	2.34	808	2.45	844	2.55	878	2.64	911	2.73	943	2.81	975	2.89	1008	2.98	1041	3.08
4600	650	2.00	683	2.15	717	2.30	753	2.44	791	2.56	829	2.66	864	2.76	897	2.84	930	2.92	962	3.00	994	3.08	1026	3.17	1060	3.26
4800	669	2.23	702	2.39	737	2.55	774	2.67	813	2.78	850	2.88	884	2.97	917	3.05	949	3.12	981	3.20	1013	3.28	1045	3.36	1079	3.45

NOTE - MSAV® (Multi-Stage Air Volume) drive is capable of 350 - 1050 rpm.

BLOWER DATA

BELT DRIVE | 20 TON

SCH240H5M BLOWER PERFORMANCE

NOTE - Blower Table Includes Resistance For Base Unit With Electric Heat, Wet Indoor Coil And Air Filters In Place.

NOTE - MINIMUM AIR VOLUME REQUIRED FOR USE WITH OPTIONAL ELECTRIC HEAT - 8000 CFM.

See Blower Motor / Drive Kit Table on page 8 for Motor HP and Drive Kit RPM Ranges Available.

Air Volume cfm	EXTERNAL STATIC PRESSURE - In. w.g.																											
	0.1		0.2		0.3		0.4		0.5		0.6		0.7		0.8		0.9		1.0		1.1		1.2		1.3			
	RPM	BHP	RPM	BHP	RPM	BHP	RPM	BHP	RPM	BHP	RPM	BHP	RPM	BHP	RPM	BHP	RPM	BHP	RPM	BHP	RPM	BHP	RPM	BHP	RPM	BHP	RPM	BHP
2000	255	0.33	310	0.48	366	0.63	416	0.74	458	0.81	498	0.89	537	0.99	573	1.10	607	1.22	642	1.35	677	1.49	712	1.65	749	1.80	786	1.96
2200	258	0.37	313	0.52	369	0.67	418	0.78	460	0.85	500	0.92	538	1.03	574	1.15	609	1.27	643	1.40	678	1.55	714	1.70	751	1.86	788	2.01
2400	261	0.40	316	0.56	372	0.70	421	0.81	462	0.88	502	0.96	540	1.07	576	1.19	610	1.32	645	1.45	680	1.60	716	1.76	753	1.92	790	2.07
2600	265	0.44	319	0.60	375	0.74	423	0.85	464	0.92	505	1.00	542	1.11	578	1.24	612	1.37	646	1.51	682	1.66	718	1.82	755	1.98	792	2.13
2800	268	0.48	322	0.63	378	0.77	426	0.89	467	0.95	507	1.04	545	1.16	580	1.29	614	1.42	648	1.56	684	1.72	720	1.88	757	2.04	794	2.19
3000	272	0.51	326	0.67	382	0.81	429	0.92	470	0.99	510	1.09	547	1.21	582	1.34	616	1.48	650	1.63	686	1.78	723	1.94	759	2.10	796	2.25
3200	276	0.55	330	0.71	386	0.85	433	0.96	473	1.03	513	1.13	550	1.26	584	1.40	618	1.54	652	1.69	688	1.85	725	2.01	762	2.16	799	2.30
3400	280	0.59	335	0.74	391	0.88	437	1.00	477	1.08	516	1.18	552	1.32	587	1.46	620	1.61	655	1.76	691	1.91	727	2.07	764	2.23	801	2.37
3600	285	0.62	340	0.78	395	0.92	441	1.04	480	1.12	520	1.24	555	1.38	589	1.53	623	1.67	657	1.83	693	1.98	730	2.14	767	2.30	804	2.44
3800	290	0.66	345	0.81	400	0.96	445	1.08	484	1.17	523	1.29	559	1.44	592	1.59	626	1.74	660	1.90	696	2.06	733	2.22	770	2.38	807	2.52
4000	296	0.69	351	0.85	406	0.99	449	1.12	488	1.22	527	1.35	562	1.51	595	1.66	629	1.82	663	1.97	699	2.14	736	2.30	773	2.46	810	2.60
4200	301	0.73	358	0.88	411	1.03	453	1.17	493	1.27	531	1.41	565	1.57	599	1.73	632	1.89	666	2.05	702	2.22	739	2.39	776	2.56	813	2.70
4400	308	0.76	364	0.92	416	1.07	458	1.22	497	1.33	534	1.48	569	1.64	602	1.81	635	1.97	670	2.14	706	2.31	743	2.48	779	2.66	816	2.80
4600	315	0.80	371	0.95	422	1.12	463	1.26	502	1.39	539	1.54	573	1.71	606	1.88	639	2.05	673	2.22	710	2.40	746	2.58	783	2.76	820	2.90
4800	322	0.83	378	0.99	427	1.16	468	1.32	507	1.45	543	1.62	577	1.79	609	1.96	642	2.14	677	2.32	714	2.50	751	2.69	788	2.87	823	3.04
5000	330	0.86	386	1.03	433	1.21	473	1.38	512	1.52	547	1.69	581	1.87	613	2.05	647	2.22	682	2.41	718	2.60	755	2.79	792	2.98	828	3.12
5200	338	0.89	393	1.07	438	1.27	478	1.44	517	1.59	551	1.77	585	1.95	617	2.13	651	2.32	686	2.50	722	2.70	759	2.89	796	3.08	831	3.21
5400	346	0.92	400	1.12	444	1.33	484	1.51	522	1.67	556	1.86	589	2.04	622	2.23	655	2.41	690	2.60	727	2.79	764	2.98	801	3.17	834	3.30
5600	355	0.96	407	1.17	450	1.40	490	1.58	528	1.76	561	1.96	594	2.14	626	2.33	660	2.51	695	2.70	732	2.89	769	3.08	806	3.27	837	3.40
5800	364	1.00	414	1.23	457	1.47	496	1.65	533	1.85	566	2.06	599	2.24	631	2.43	665	2.61	701	2.81	737	3.00	774	3.19	811	3.38	840	3.51
6000	372	1.04	422	1.29	463	1.54	502	1.73	539	1.95	571	2.17	604	2.35	636	2.53	670	2.72	706	2.91	743	3.11	779	3.30	816	3.50	843	3.63
6200	381	1.08	429	1.36	470	1.62	508	1.82	544	2.05	576	2.28	609	2.46	641	2.64	676	2.82	712	3.02	749	3.22	785	3.42	822	3.62	846	3.75
6400	390	1.14	437	1.44	477	1.71	515	1.92	550	2.16	582	2.39	614	2.57	647	2.74	682	2.93	718	3.14	755	3.34	792	3.54	828	3.75	850	3.87
6600	399	1.20	444	1.53	484	1.80	521	2.02	556	2.28	587	2.51	620	2.68	653	2.85	688	3.04	725	3.25	762	3.46	798	3.67	835	3.87	854	4.00
6800	408	1.27	452	1.62	491	1.89	528	2.13	562	2.40	593	2.63	625	2.80	659	2.96	694	3.15	731	3.37	768	3.58	805	3.80	842	4.01	860	4.14
7000	417	1.35	460	1.71	498	1.99	535	2.24	568	2.52	599	2.74	631	2.91	665	3.08	700	3.27	737	3.48	775	3.70	812	3.92	848	4.14	864	4.27
7200	426	1.45	467	1.82	505	2.10	541	2.36	574	2.65	606	2.86	638	3.02	671	3.19	707	3.39	744	3.60	781	3.83	818	4.05	855	4.27	870	4.40
7400	435	1.55	475	1.93	513	2.22	548	2.49	580	2.77	612	2.98	644	3.14	677	3.31	713	3.50	750	3.72	788	3.94	825	4.17	861	4.39	876	4.51
7600	444	1.67	483	2.05	520	2.34	555	2.62	587	2.90	618	3.10	650	3.26	684	3.43	719	3.62	756	3.84	794	4.06	831	4.29	868	4.51	883	4.62
7800	452	1.80	491	2.18	528	2.47	562	2.75	594	3.02	625	3.22	657	3.38	690	3.55	726	3.74	763	3.96	800	4.18	837	4.40	874	4.62	889	4.74
8000	461	1.93	500	2.31	536	2.61	570	2.89	601	3.15	632	3.35	664	3.51	697	3.67	732	3.87	769	4.08	806	4.30	843	4.52	880	4.74	895	4.86
8200	470	2.08	508	2.45	544	2.75	577	3.03	608	3.29	639	3.47	671	3.63	704	3.80	739	3.99	775	4.20	812	4.42	849	4.64	886	4.86	901	4.98
8400	479	2.23	516	2.60	552	2.90	585	3.18	615	3.42	646	3.60	678	3.76	711	3.93	746	4.11	782	4.32	819	4.54	855	4.76	892	4.98	907	5.10
8600	488	2.39	525	2.76	560	3.05	592	3.33	623	3.56	653	3.74	685	3.89	718	4.06	752	4.24	788	4.44	825	4.66	862	4.88	898	5.10	912	5.22
8800	498	2.56	533	2.91	568	3.21	600	3.48	630	3.70	661	3.87	692	4.02	725	4.19	759	4.37	795	4.57	831	4.78	868	5.00	904	5.21	919	5.33
9000	507	2.73	542	3.08	576	3.37	608	3.63	638	3.85	668	4.01	699	4.16	732	4.32	766	4.50	802	4.69	838	4.90	874	5.12	911	5.33	926	5.46
9200	516	2.91	551	3.25	584	3.53	616	3.78	645	3.99	676	4.15	707	4.29	739	4.45	773	4.63	808	4.82	844	5.03	881	5.24	917	5.46	932	5.58
9400	526	3.09	560	3.42	593	3.69	623	3.94	653	4.13	683	4.28	714	4.43	746	4.58	780	4.76	815	4.95	851	5.15	887	5.36	923	5.58	937	5.70
9600	535	3.27	569	3.59	601	3.86	631	4.10	661	4.28	691	4.42	721	4.56	753	4.72	787	4.89	822	5.08	858	5.28	894	5.49	930	5.70	945	5.82

BLOWER DATA

MSAV® (MULTI-STAGE AIR VOLUME) BELT DRIVE KIT SPECIFICATIONS

Size	Nominal / Maximum - hp	Drive Kit Number	RPM Range
120	3	#3	660 - 900
		#4	865 - 1080
240	5	#4	520 - 685
		#5	685 - 865
	7.5	#7	770 - 965

FACTORY INSTALLED OPTIONS/FIELD INSTALLED ACCESSORY AIR RESISTANCE - in. w.g.

Air Volume cfm	Humiditrol Dehumidification Coil	Economizer	Filters MERV 13
120 Size			
2000	0.03	0.06	0.03
2500	0.04	0.11	0.05
3000	0.05	0.13	0.06
3500	0.06	0.15	0.07
4000	0.08	0.19	0.08
4500	0.10	0.22	0.09
5000	0.12	0.29	0.10
5500	0.14	0.34	0.12
6000	0.15	0.52	0.13
240 Size			
3000	0.02	0.00	0.00
3500	0.04	0.00	0.00
4000	0.04	0.00	0.00
4500	0.04	0.00	0.00
5000	0.04	0.00	0.00
5500	0.06	0.01	0.01
6000	0.06	0.01	0.02
6500	0.08	0.01	0.02
7000	0.08	0.02	0.03
7500	0.10	0.02	0.04
8000	0.10	0.02	0.04
8500	0.10	0.03	0.04
9000	0.12	0.04	0.04
9500	0.14	0.04	0.06

POWER EXHAUST FANS STANDARD STATIC PERFORMANCE

120 Model		240 Model	
Return Air System Static Pressure	Air Volume Exhausted	Return Air System Static Pressure	Air Volume Exhausted
in. w.g.	cfm	in. w.g.	cfm
0.05	4085	0	10,200
0.10	3685	0.05	9700
0.15	3280	0.10	9200
0.20	2880	0.15	8600
0.25	2475	0.20	8100
---	---	0.25	7600
---	---	0.30	6900
---	---	0.35	6000
---	---	0.40	5000
---	---	0.45	4150

ELECTRICAL/ELECTRIC HEAT DATA

BELT DRIVE | 10 TON

Model		SCH120H5M	
¹ Voltage - 60Hz		460V-3ph	575V-3ph
Compressor (Non-Inverter)	Rated Load Amps	6.5	4.8
	Locked Rotor Amps	60	41
Compressor (Non-Inverter)	Rated Load Amps	6.6	4.8
	Locked Rotor Amps	60	41
Outdoor Fan Motors	Full Load Amps (2 Non-ECM)	1.5	1.2
	Total	3	2.4
Power Exhaust (1) 0.5 HP	Full Load Amps	1.5	1.2
Service Outlet 115V GFI (Amps)		20	20
Indoor Blower Motor	HP	3	3
	Type	Belt	Belt
	Full Load Amps	4.8	3.9
² Maximum Overcurrent Protection (MOCP)	Unit Only	25	20
	With (1) 0.5 HP Power Exhaust	30	20
³ Minimum Circuit Ampacity (MCA)	Unit Only	23	18
	With (1) 0.5 HP Power Exhaust	25	19

ELECTRIC HEAT DATA

Electric Heat Voltage			480V	600V
² Maximum Overcurrent Protection (MOCP)	Unit+ Electric Heat	15 kW	30	25
		20 kW	40	---
		30 kW	60	45
		45 kW	80	60
		60 kW	80	70
³ Minimum Circuit Ampacity (MCA)	Unit+ Electric Heat	15 kW	29	23
		20 kW	37	---
		30 kW	52	41
		45 kW	74	60
		60 kW	79	63
² Maximum Overcurrent Protection (MOCP)	Unit+ Electric Heat and (1) 0.5 HP Power Exhaust	15 kW	35	25
		20 kW	40	---
		30 kW	60	45
		45 kW	80	70
		60 kW	90	70
³ Minimum Circuit Ampacity (MCA)	Unit+ Electric Heat and (1) 0.5 HP Power Exhaust	15 kW	31	25
		20 kW	38	---
		30 kW	53	43
		45 kW	76	61
		60 kW	81	65

NOTE - All units have a minimum Short Circuit Current Rating (SCCR) of 35kA.

¹ NOTE - Extremes of operating range are plus and minus 10% of line voltage.

² HACR type breaker or fuse.

³ Refer to National or Canadian Electrical Code manual to determine wire, fuse and disconnect size requirements.

ELECTRICAL/ELECTRIC HEAT DATA

BELT DRIVE | 20 TON

Model		SCH240H5			
		460V-3ph		575V-3ph	
¹ Voltage - 60Hz					
Compressor (Non-Inverter)	Rated Load Amps	6.6		4.8	
	Locked Rotor Amps	60		41	
Compressor (Non-Inverter)	Rated Load Amps	6.6		4.8	
	Locked Rotor Amps	60		41	
Compressor (Non-Inverter)	Rated Load Amps	6.6		4.8	
	Locked Rotor Amps	60		41	
Compressor (Non-Inverter)	Rated Load Amps	6.6		4.8	
	Locked Rotor Amps	60		41	
Outdoor Fan Motors (6)	Full Load Amps (6 Non-ECM)	1.3		1	
	Total	7.8		6	
Power Exhaust (3) 0.33 HP	Full Load Amps	1.3		1	
	Total	3.9		3	
Service Outlet 115V GFI (Amps)		20		20	
Indoor Blower Motor	HP	5	7.5	5	7.5
	Type	Belt	Belt	Belt	Belt
	Full Load Amps	7.6	11	6.1	9
² Maximum Overcurrent Protection (MOCP)	Unit Only	50	50	35	45
	With (3) 0.33 HP Power Exhaust	50	60	40	45
³ Minimum Circuit Ampacity (MCA)	Unit Only	44	48	33	37
	With (3) 0.33 HP Power Exhaust	48	52	36	40

ELECTRIC HEAT DATA

Electric Heat Voltage			480V	480V	600V	600V
² Maximum Overcurrent Protection (MOCP)	Unit+ Electric Heat	30 kW	60	60	45	50
		40 kW	70	80	---	---
		60 kW	90	90	70	70
		90 kW	125	125	100	100
³ Minimum Circuit Ampacity (MCA)	Unit+ Electric Heat	30 kW	55	59	44	48
		40 kW	70	74	---	---
		60 kW	82	86	66	69
		90 kW	118	123	95	98
² Maximum Overcurrent Protection (MOCP)	Unit+ Electric Heat and (3) 0.33 HP Power Exhaust	30 kW	60	70	50	60
		40 kW	80	80	---	---
		60 kW	90	100	70	80
		90 kW	125	150	100	110
³ Minimum Circuit Ampacity (MCA)	Unit+ Electric Heat and (3) 0.33 HP Power Exhaust	30 kW	60	64	48	52
		40 kW	75	79	---	---
		60 kW	87	91	70	73
		90 kW	123	127	98	102

NOTE - All units have a minimum Short Circuit Current Rating (SCCR) of 35kA.

¹ NOTE - Extremes of operating range are plus and minus 10% of line voltage.

² HACR type breaker or fuse.

³ Refer to National or Canadian Electrical Code manual to determine wire, fuse and disconnect size requirements.

⁴ Factory installed circuit breaker not available.

ELECTRIC HEAT CAPACITIES

Volts Input	10 kW			15 kW			20 kW			30 kW		
	kW Input	Btuh Output	Stages	kW Input	Btuh Output	Stages	kW Input	Btuh Output	Stages	kW Input	Btuh Output	Stages
440	8.4	28,700	1	12.6	43,000	1	18.3	62,600	1	25.2	86,000	2
460	9.2	31,400	1	13.8	47,100	1	19.2	65,400	1	27.5	93,900	2
480	10.0	34,200	1	15.0	51,200	1	20.0	68,200	1	30.0	102,400	2
550	8.4	28,700	1	12.6	43,000	1	18.3	62,600	1	25.2	86,000	2
575	9.2	31,400	1	13.8	47,100	1	19.2	65,400	1	27.5	93,900	2
600	10.0	34,200	1	15.0	51,200	1	20.0	68,200	1	30.0	102,400	2

ELECTRIC HEAT CAPACITIES

Volts Input	40 kW			45 kW			60 kW			90 kW		
	kW Input	Btuh Output	Stages	kW Input	Btuh Output	Stages	kW Input	Btuh Output	Stages	kW Input	Btuh Output	Stages
440	32.8	112,000	2	37.8	129,000	2	50.4	172,000	2	75.6	258,000	2
460	35.9	122,400	2	41.3	141,000	2	55.1	188,000	2	82.7	282,200	2
480	39	133,200	2	45.0	153,600	2	60.0	204,800	2	90.0	307,100	2
550	33.6	114,800	2	37.8	129,000	2	50.4	172,000	2	75.6	258,000	2
575	36.7	125,500	2	41.3	141,000	2	55.1	188,000	2	82.7	282,200	2
600	40	136,600	2	45.0	153,600	2	60.0	204,800	2	90.0	307,100	2

MINIMUM R454B SPACE AND CFM REQUIREMENTS

Minimum Airflow ¹		
Unit	Q _{min} (CFM)	Q _{min} (m ³ /h)
SGH/SCH120 circ 1	185	314
SGH/SCH120 circ 2	127	216
SGH/SCH120 circ 1W/ Humidtrol	185	314
SGH/SCH120 circ2 W/ Humidtrol	135	230
SGH/SCH240 circ 1	177	300
SGH/SCH240 circ 2	160	272
SGH/SCH240 circ 3	134	227
SGH/SCH240 circ 4	137	233
SGH/SCH240 circ 1 W/ Humidtrol	205	348
SGH/SCH240 circ 2 W/ Humidtrol	190	323
SGH/SCH240 circ 3 W/ Humidtrol	140	239
SGH/SCH240 circ 4 W/ Humidtrol	142	241

¹ The minimum airflow is the lowest CFM allowed during venting operation (leak mitigation).

Minimum Room Area of Conditioned Space ²		
Unit	TA _{min} (ft ²)	TA _{min} (m ²)
SGH/SCH120 circ 1	102.54	9.53
SGH/SCH120 circ 2	70.46	6.55
SGH/SCH120 circ 1W/ Humidtrol	102.54	9.53
SGH/SCH120 circ2 W/ Humidtrol	75.07	6.97
SGH/SCH240 circ 1	97.97	9.10
SGH/SCH240 circ 2	88.81	8.25
SGH/SCH240 circ 3	74.16	6.89
SGH/SCH240 circ 4	76.00	7.06
SGH/SCH240 circ 1 W/ Humidtrol	113.53	10.55
SGH/SCH240 circ 2 W/ Humidtrol	105.29	9.78
SGH/SCH240 circ 3 W/ Humidtrol	77.82	7.23
SGH/SCH240 circ 4 W/ Humidtrol	78.74	7.31

² The minimum room area of conditioned space is the smallest area the unit can service.

Refrigerant Charge R-454B		
Unit	M _c (lbs)	M _c (kg)
SGH/SCH120 circ 1	7.00	3.18
SGH/SCH120 circ 2	4.81	2.18
SGH/SCH120 circ 1W/ Humidtrol	7.00	3.18
SGH/SCH120 circ2 W/ Humidtrol	5.13	2.32
SGH/SCH240 circ 1	6.69	3.03
SGH/SCH240 circ 2	6.06	2.75
SGH/SCH240 circ 3	5.06	2.30
SGH/SCH240 circ 4	5.19	2.35
SGH/SCH240 circ 1 W/ Humidtrol	7.75	3.52
SGH/SCH240 circ 2 W/ Humidtrol	7.19	3.26
SGH/SCH240 circ 3 W/ Humidtrol	5.31	2.41
SGH/SCH240 circ 4 W/ Humidtrol	5.38	2.44

Altitude Adjustment Factor ³									
Halt	0	200	400	600	800	1000	1200	1400	1600
AF	1	1	1	1	1.02	1.05	1.04	1.1	1.12
Halt	1600	1800	2000	2200	2400	2600	2800	3000	3200
AF	1.12	1.15	1.18	1.21	1.25	1.28	1.32	1.36	1.4

³ Use the Altitude Adjustment Factor to adjust the values in the table above to different altitudes. Find the relevant altitude above sea level in two "Halt" rows and then multiply the value from the table above by the factor number. Example for a SCH120 at 1000 ft. above sea level, multiply 185 by 1.05 to get 194.255_{min}.

SCH120 Parts Arrangement

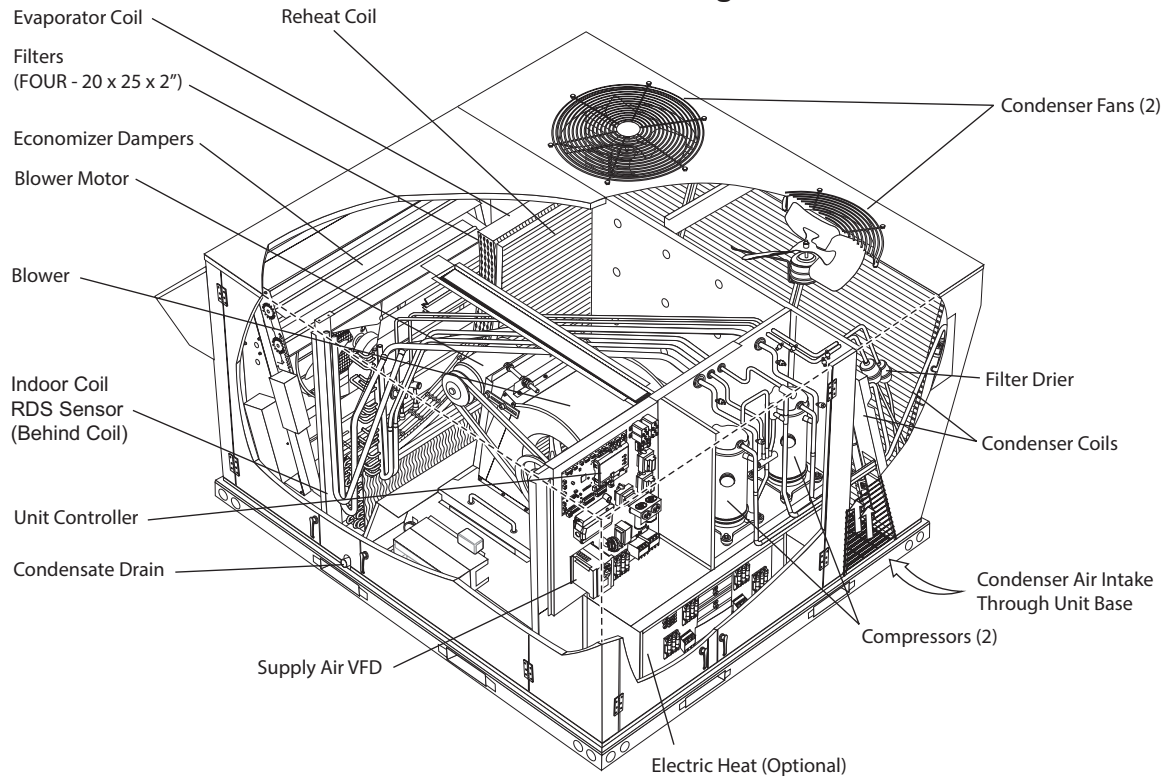

FIGURE 1

SCH240 Parts Arrangement

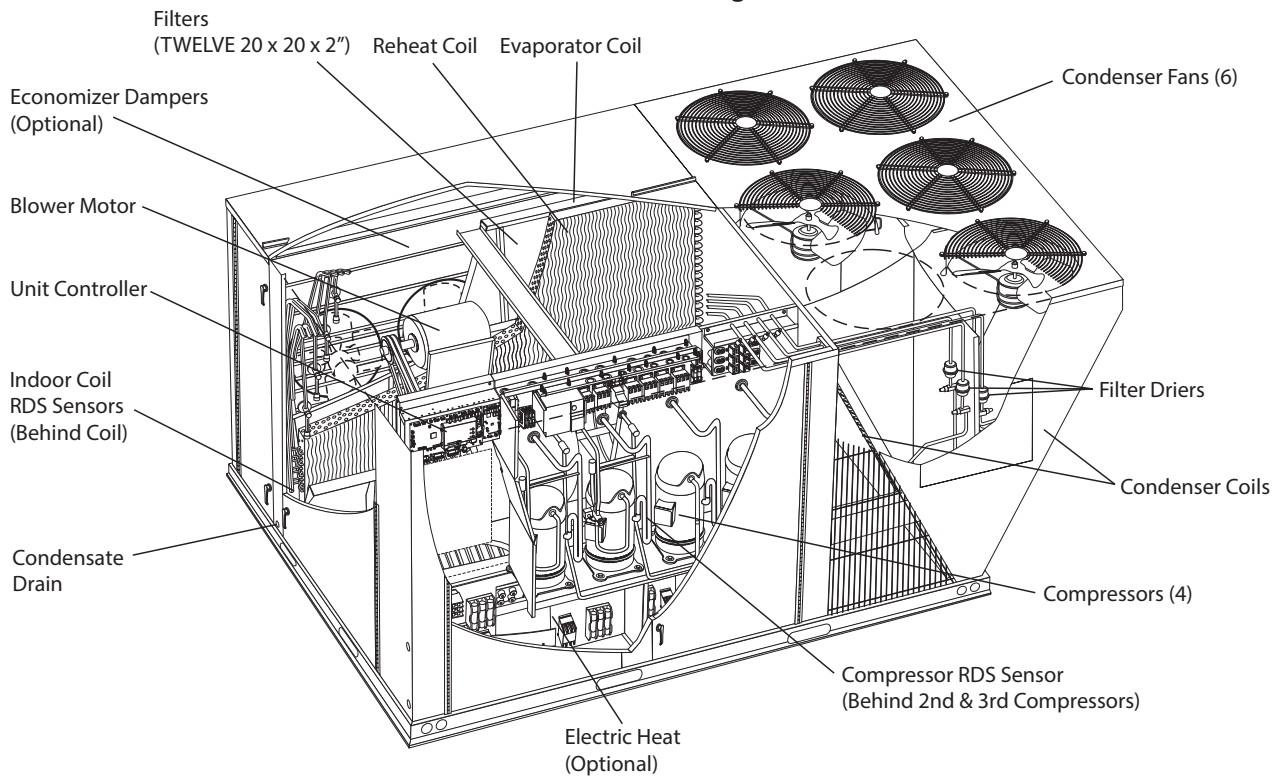

FIGURE 2

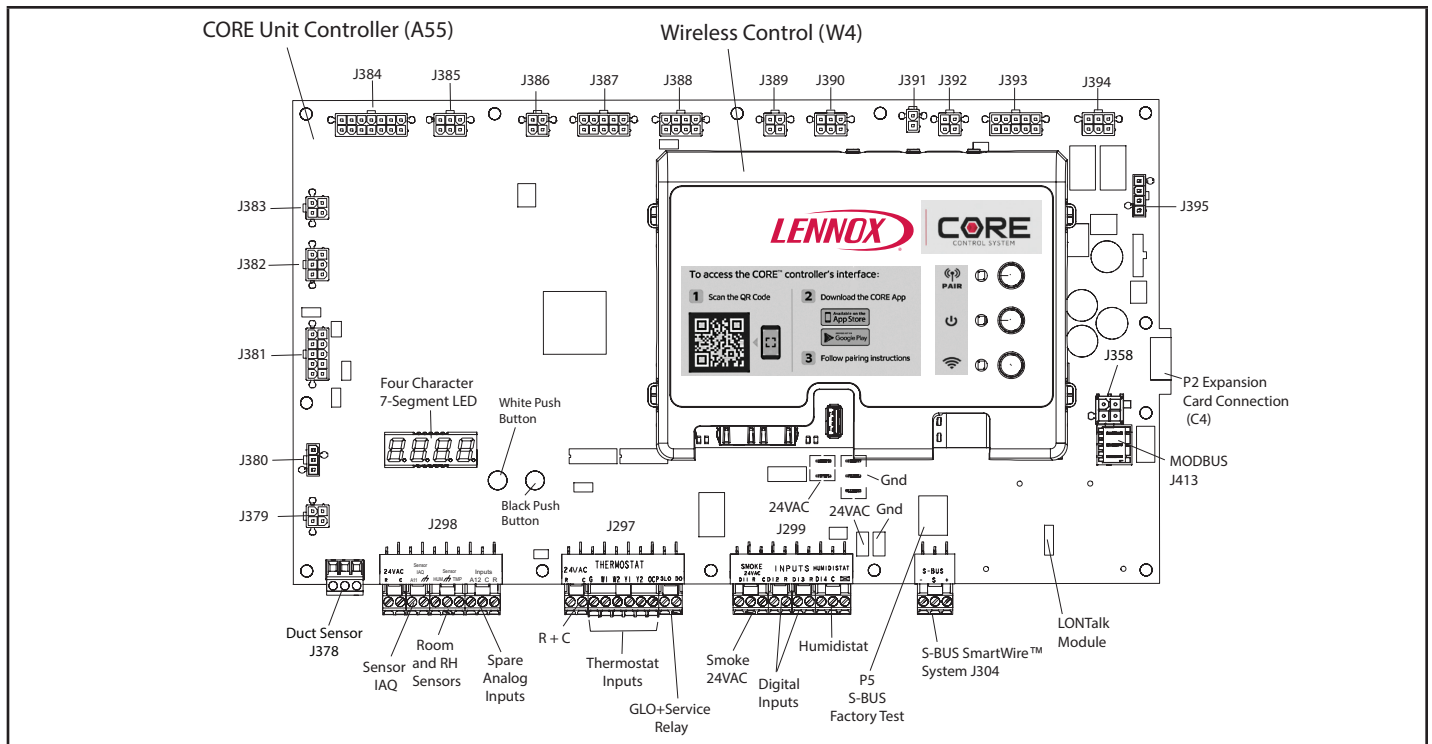

FIGURE 3

I-UNIT COMPONENTS

All units are configured to order units (CTO). Unit components are shown in FIGURE 1 and FIGURE 2. All units come standard with hinged unit panels. The unit panels may be held open with the door rod located inside the unit. All L1, L2 and L3 wiring is color coded; L1 is red, L2 is yellow and L3 is blue.

**ELECTROSTATIC DISCHARGE (ESD)
Precautions and Procedures**



CAUTION



Electrostatic discharge can affect electronic components. Take precautions to neutralize electrostatic charge by touching your hand and tools to metal prior to handling the control.

A-Control Box Components

1-Circuit Breaker CB10

All units are equipped with circuit breaker CB10. Circuit breaker CB10 is a toggle switch which can be used by the service technician to disconnect power to the unit.

2-Control Transformer T1

All use a single line voltage to 24VAC transformer mounted in the control box. Transformer supplies power to control circuits in the unit. The transformer is rated at 70VA and is protected by a 3.5 amp circuit breaker (CB8). The 460 (G) and 575 (J) voltage transformers use a single primary voltage tap.

3-Contactor Transformer T18 (240 only)

T18 is a single line voltage to 24VAC transformer used in the 20 ton units. Transformer T18 is protected by a 3.5 amp circuit breaker (CB18). T18 is identical to transformer T1. The transformer supplies 24VAC power to the contactors.

4-Terminal Block TB13 (240 only)

TB13 terminal block distributes line voltage power to the line voltage items in the unit.

5-Terminal Block TB13 (240 only)

TB13 terminal block distributes line voltage power to the line voltage items in the unit.

6-Transformer T43 (all units)

All reheat units and units with phase detection components are equipped with transformer T43 located in the control box. The transformer is rated at 70VA and is protected by a 3.5 amp circuit breaker (CB31). The 460(G) and 575(J) voltage transformers use a single primary tap.

7-Outdoor Fan Relay K10,K68 (120 only) and K10,K68, K149, K150, K152, K153 (240 units)

Outdoor fan relays are DPDT relays with a 24VAC coil used to power the outdoor fans. Relays are energized by the CORE board (A55) depending on the unit operation.

8-Compressor Contactor K1, K2, K14, K146

K1, K2: All units

K14, K146: 240 units

All compressor contactors are three-pole-double-break contactors with 24VAC coils. In all units K1 (energized by A55) energizes compressors B1 in response to first stage cool demand, and K2 (energized by A55) energizes B2 in response to second stage cool demand. In the 240 units K14 and K146 (energized by A178) energize compressors B13 and B20 in response to second stage cool demand.

9-Power Exhaust Relay K65 all units & K231 240 units (PED units)

K65: All units

K231: 240 units

Power exhaust relays K65 and K231 are N.O. DPDT relays with a 24VAC coil. The relays are used in units equipped with the optional power exhaust dampers. K65 and K231 are energized by the A55 Unit Controller, after the economizer dampers reach 50% open (adjustable in ECTO). When K65 closes, exhaust fan B10 is energized and when K231 closes B11 is energized.

10-Variable Frequency Drive A96 (optional)

Staged-Blower units are equipped with a VFD which alters the supply power frequency and voltage to the blower motor. Blower speed is staged depending on the compressor stages, heating demand, ventilation demand, or smoke alarm. The amount of airflow for each stage is preset from the factory. Airflow can be adjusted by changing ECTO parameters in the A55 Unit Controller. The VFD is located below the Unit Controller.

11-Unit Controller A55 (FIGURE 3)

The Unit Controller provides all unit control functions, unit status information, unit diagnostics, programmable parameters and USB verification and profile sharing. Refer to the Unit Controller guide provided with the unit.

Thermostat wires are connected to J297 on the Unit Controller.

12-Compressor 3 & 4 Controller (240 Only)

The compressor 3 & 4 control module A178 controls two additional compressor stages. A178 includes all inputs and outputs required for compressor and fan control, compressor stage diagnostics and low ambient control.

13-Enthalpy Sensor - Optional

The optional enthalpy sensors (A7 and A63) used with the economizer have an output of 4-20mA. The sensor is powered with 18VAC provided by M4 unit control.

14-Economizer Differential Pressure Sensor - Option

Rooftop units installed with Smart Airflow™ will have a Pressure Transducer (PT5) present in the economizer. PT5 requires 5VDC power supply (P266-5 and {P266-6) and gives 0.25 VDC to 4 VDC output (P266-4) corresponding to 0" water column and 2" water column respectively. For all practical purposes the output should be less than 1.2" water column if not an error code is stored and service alarm output is turned on.

15-Temperature Sensors

The return air (RT16) and discharge air (RT6) duct probes and the outdoor air (RT17) are all two wire thermistors. See FIGURE 4 for locations.

16-Wireless Antenna

Wireless antenna is located above the return air compartment of the unit. Please follow the CORE Controller setup guide. See FIGURE 5.

17-Outdoor Fan Transformers T5

All 460 (G) and 575 (J) voltage units use transformer T5. The auto voltage to 230VAC transformer is mounted in the control box. The transformer has an output rating of 0.5A. T5 transformer supplies 230 VAC power to outdoor fans B21 (156), B5 & B22 (180/210), B21 & B24 (240/300).

18 - Short Circuit Rating Fuse F10 & F6

F10 fuses provide SCCR over-current protection up to 35kA to all components on the load side. Two line voltage fuses F6 provide over-current protection to the optional power exhaust fans on 240 units.

19-Condenser Fan Capacitors

C1, C2: All Units

C18, C19, C20, C21: 240 Units

The outdoor motors require run capacitors. Capacitor C1 is connected to OD Motor B4. C2 to B5, C18 to B21, C19 to B22, C20 to B23, & C21 to B24.

RT16 & RT17 SENSOR LOCATION

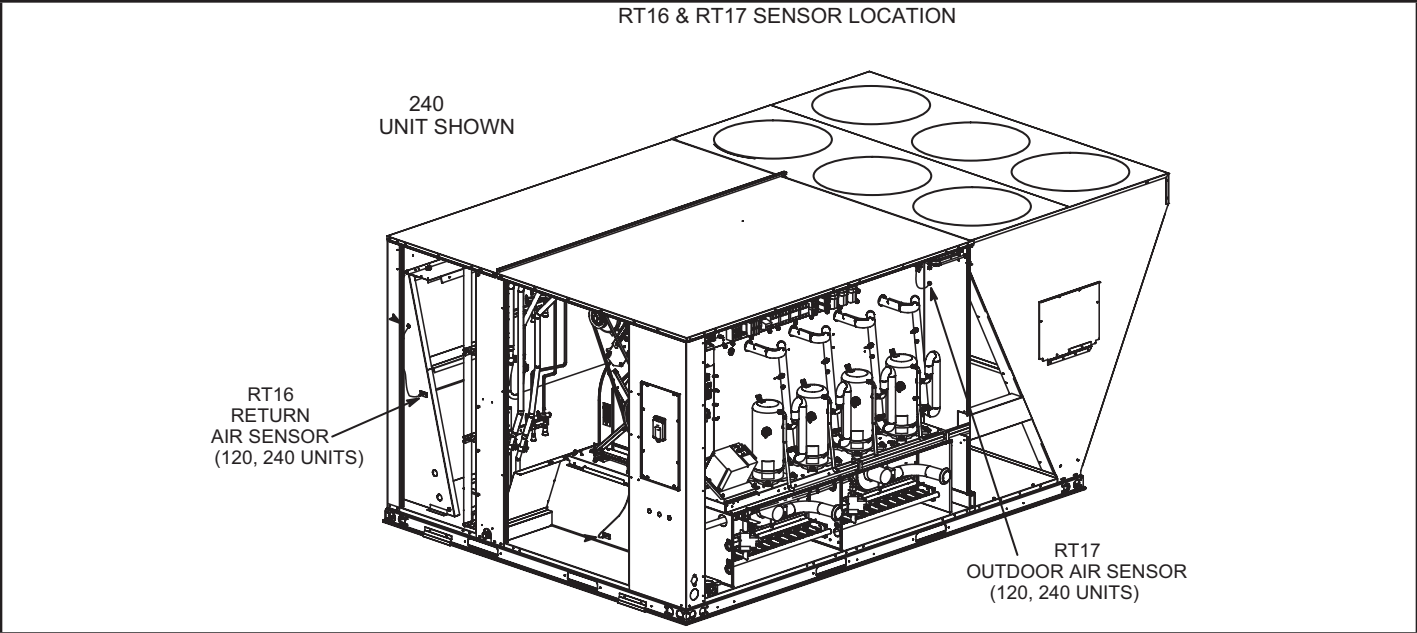

FIGURE 4

Antenna Location

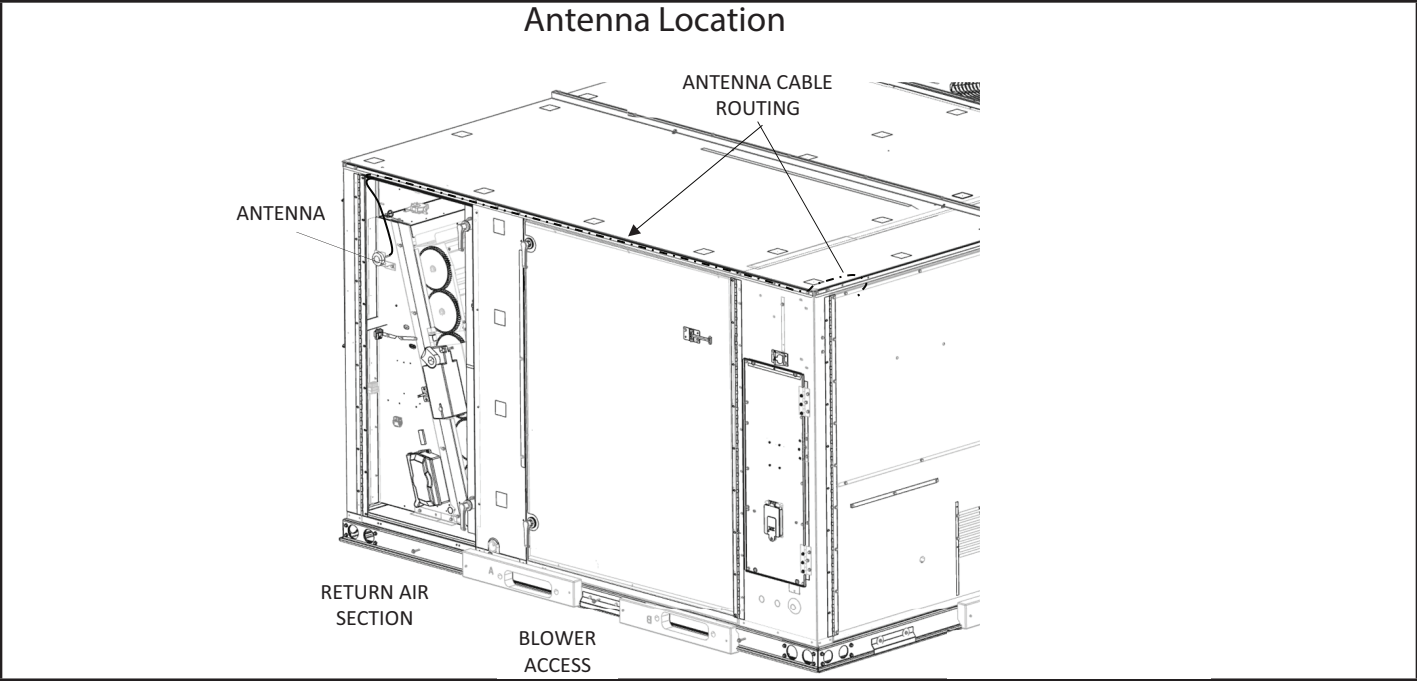

FIGURE 5

B-Cooling Components

Units use independent cooling circuits consisting of one compressor, one condenser coil, and one evaporator coil per circuit.

Two draw-through type condenser fans are used in SCH120 and six draw-through type condenser fans are used in SCH240 units.

Cooling may be supplemented by a factory-or field-installed economizer. Each evaporator uses a thermostatic expansion valve as the primary expansion device. Each evaporator is also equipped with enhanced fins and rifled tubing. In all units each compressor is protected by a crankcase heater, high pressure switch and low pressure switch.

1-Compressors B1, B2, B13, B20

All units use scroll compressors. SGH120 use 2 compressors and SCH240 use use four compressors. Compressor capacity may vary from stage to stage. In all cases, the capacity of each compressor is added to reach the total capacity of the unit. See "SPECIFICATIONS" and "ELECTRICAL DATA" (table of contents) or compressor nameplate for compressor specifications.

WARNING

Electrical shock hazard. Compressor must be grounded. Do not operate without protective coverover terminals. Disconnect power before removing protective cover. Discharge capacitors before servicing unit. Failure to follow these precautions could cause electrical shock resulting in injury or death.

Each compressor is energized by a corresponding compressor contactor.

NOTE-Refer to the wiring diagram section for specific unit operation.

If a compressor replacement is necessary, call 1-800-453-6669.

IMPORTANT

Some scroll compressors have an internal vacuum protector that will unload scrolls when suction pressure goes below 20 psig. A hissing sound will be heard when the compressor is running unloaded. Protector will reset when low pressure in system rises above 40 psig. DO NOT REPLACE COMPRESSOR.

2-Crankcase Heaters HR1, HR2, HR5 & HR11

All SGH units use insertion type heaters. Heater HR1 is installed around compressor B1, heater HR2 compressor B2, HR5 compressor B13 and HR11 compressor B20.

3-High Pressure Switches S4, S7, S28, S96

S4, S7 (120, 240 units)

S28, 296 (240 units)

The high pressure switches is an auto-reset SPST N.C. switch which opens on a pressure rise. All units are equipped with this switch. The switch is located in the compressor discharge line and is wired in series with the compressor contactor coil through A55 unit controller or A178 compressor 3 and 4 controller. See FIGURE 6 and FIGURE 7.

S4 and S7 are is wired in series with B1 and B2 compressor contactors and S28 and S96 are wired in series with B13 and B20 compressor contactors.

When discharge pressure rises to 640 ± 10 psig (indicating a problem in the system) the switch opens and the respective compressor(s) is de-energized (the economizer can continue to operate). When discharge pressure drops to 475 ± 20 psig the pressure switch will close re-energizing the compressor(s).

Main control A55 has a three-strike counter before locking out. This means the control allows three high pressure trips per one thermostat demand. The control can be reset by breaking and remaking the thermostat demand or manually resetting the control.

4-Filter Drier (all units)

Units have a filter drier located in the liquid line of each refrigerant circuit at the exit of each condenser coil. The drier removes contaminants and moisture from the system.

5-Condenser Fans

B4, B5 (210, 240 units)

B21, B22, B23 and B24 (240 units)

See SPECIFICATIONS tables at the front of this manual for specifications of condenser fans used in all units. All condenser fans used have single-phase motors. The fan assembly may be removed for servicing and cleaning.

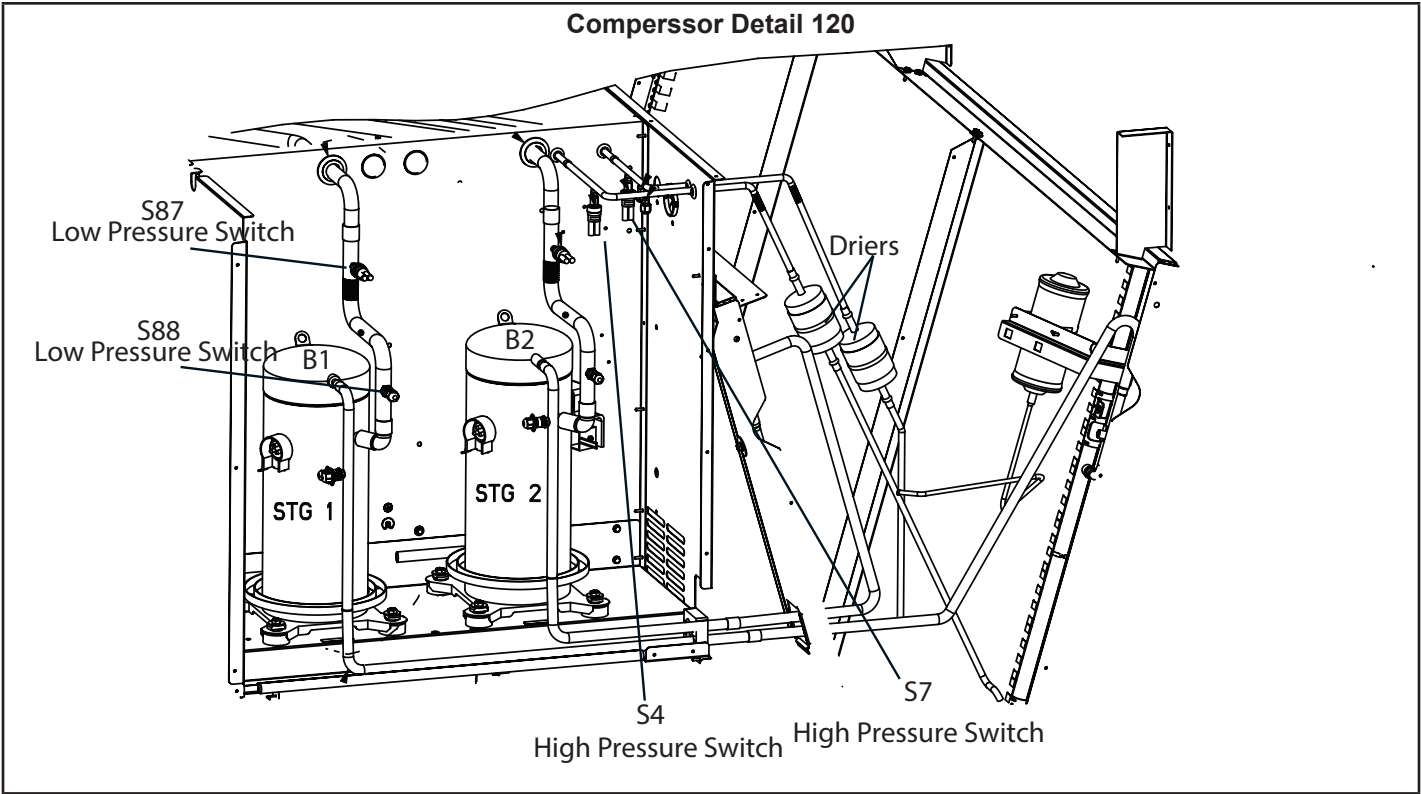

FIGURE 6

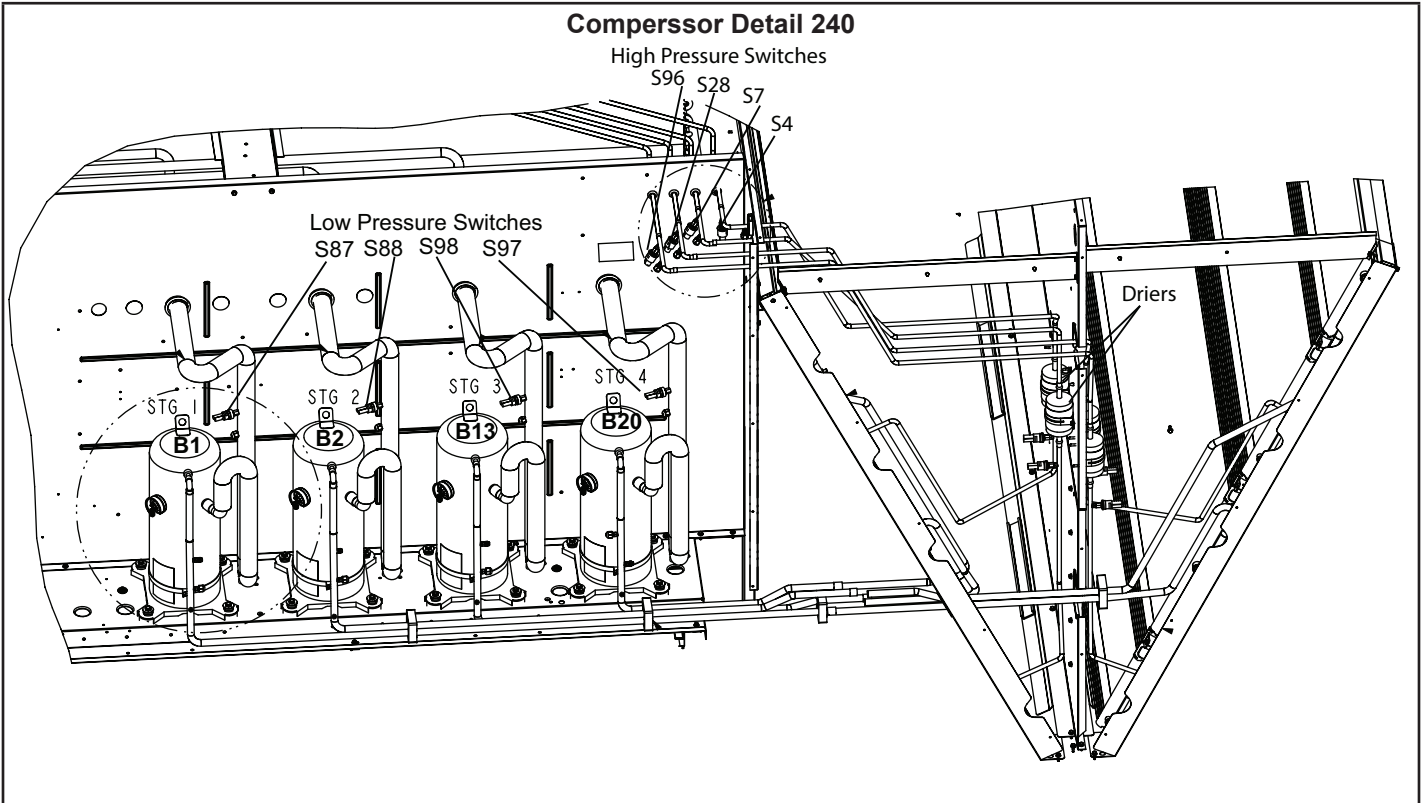

FIGURE 7

SG/SC 120 MSAV™ UNIT REFRIGERANT CIRCUITS

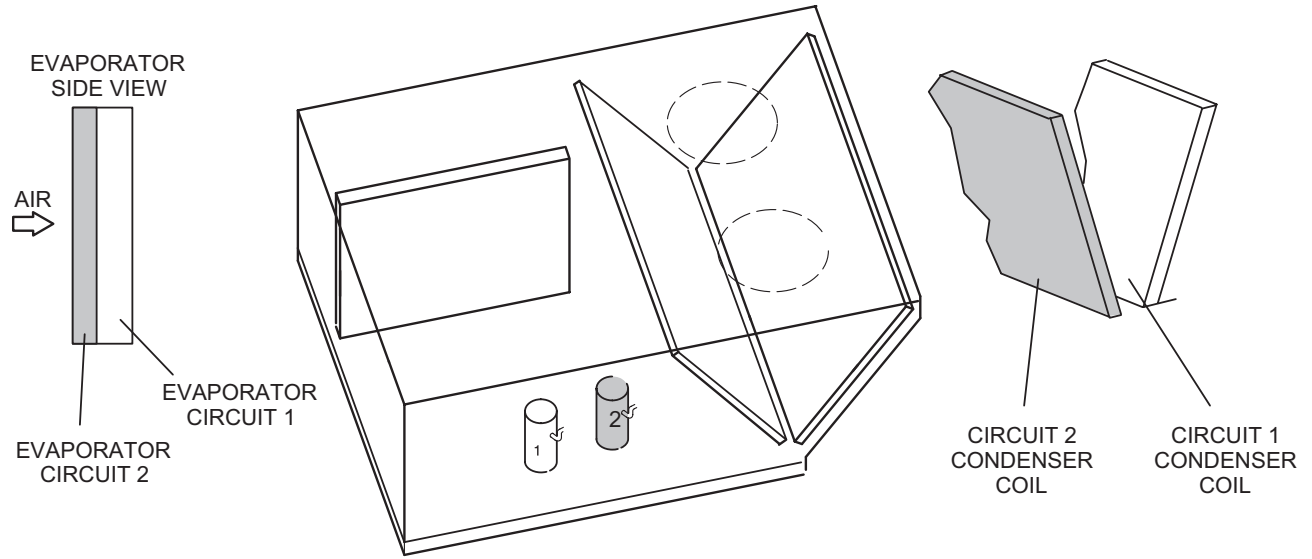

FIGURE 8

SG/SC 240 MSAV™ UNIT REFRIGERANT CIRCUITS
(IN THERMOSTAT MODE)

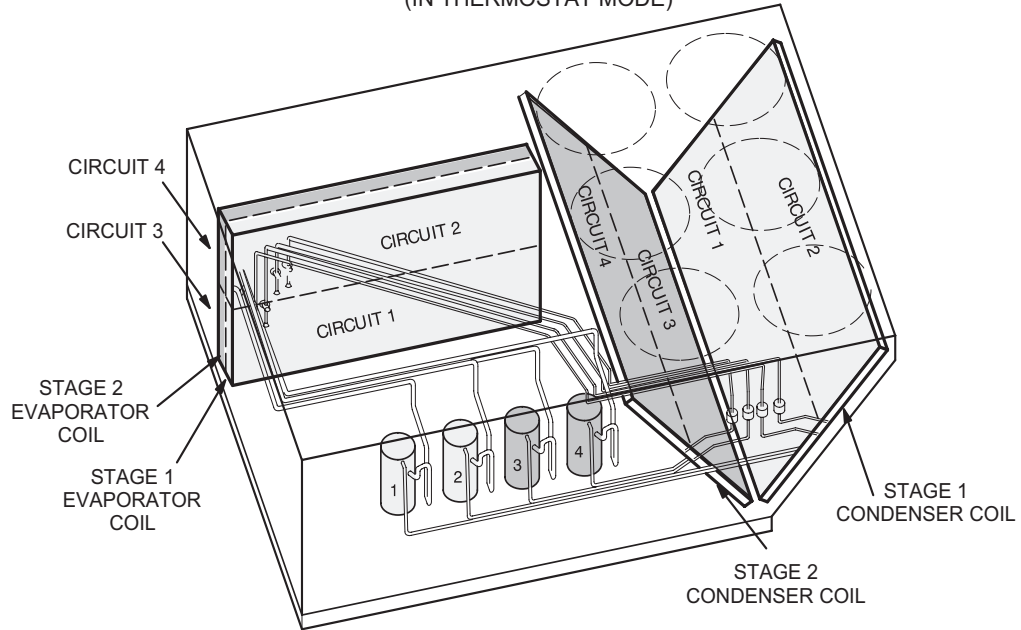

FIGURE 9

7-Temperature Thermistor

RT46/47/50/51 and RT48/49/52/53

Units are equipped with multiple factory-installed thermistors and are located on different points on the refrigerant circuit.

The thermistors provide the Unit Controller with constant temperature readings of two specific locations on the refrigeration circuit. These temperatures are used as feedback in certain modes of unit operation. In addition, the Unit Controller uses these temperatures to initiate alarms such as loss of condenser or evaporator airflow and loss of charge.

Each thermistor must be specifically placed for proper unit operation and to initiate valid alarms. See TABLE 1 for proper locations

TABLE 1

THERMISTOR LOCATION		
Unit	Sensor	Figure
120 Indoor Coil	RT46, 47	FIGURE 10
120 Outdoor Coil	RT48, 49	FIGURE 11
240 Indoor Coil	RT46, 47, 50, 51	FIGURE 12
240 Outdoor Coil	RT48, 49, 52, 53	FIGURE 13

8-Low Pressure Switches S87, S88, S97, S98

S87 all units

S88 all units

S97 180, 210, 240, 300 units

S98 210, 240, 300 units

The low pressure switch is an auto-reset SPST N.O. switch (held N.C. by refrigerant pressure) which opens on a pressure drop. All units are equipped with this switch. The switch is located in the compressor suction line. See FIGURE 6 and FIGURE 7 .

S87 and S88 (compressor one and two) and S98 (compressor three) and S98 (compressor 4) are wired in series with the contactor coils through the A55 Unit Controller

The Unit Controller A55 governs the low pressure switches by shunting the switches during start up until pressure is stabilized. After the shunt period, the control has a three-strike counter, during a single thermostat demand, before the compressor(s) is locked out. The control is re-set by breaking and remaking the thermostat demand or manually resetting the control.

When suction pressure drops to 40 ± 5 psig (indicating low pressure), the switch opens and the compressor(s) is de-energized. The switch automatically resets when pressure in the suction line rises to 90 ± 5 psig.

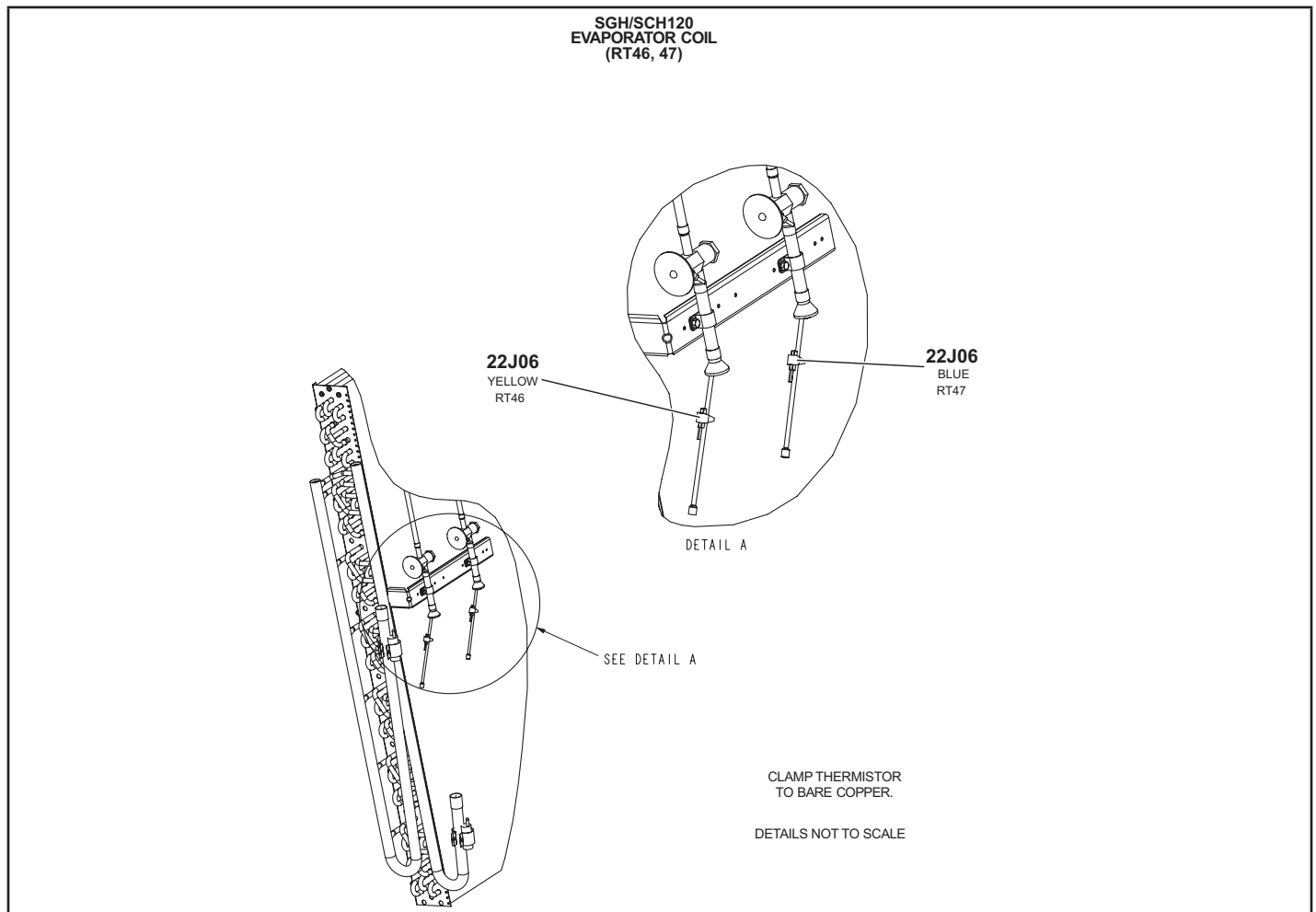

FIGURE 10

SGH/SCH120
CONDENSER / OUTDOOR COIL
(RT48, 49)

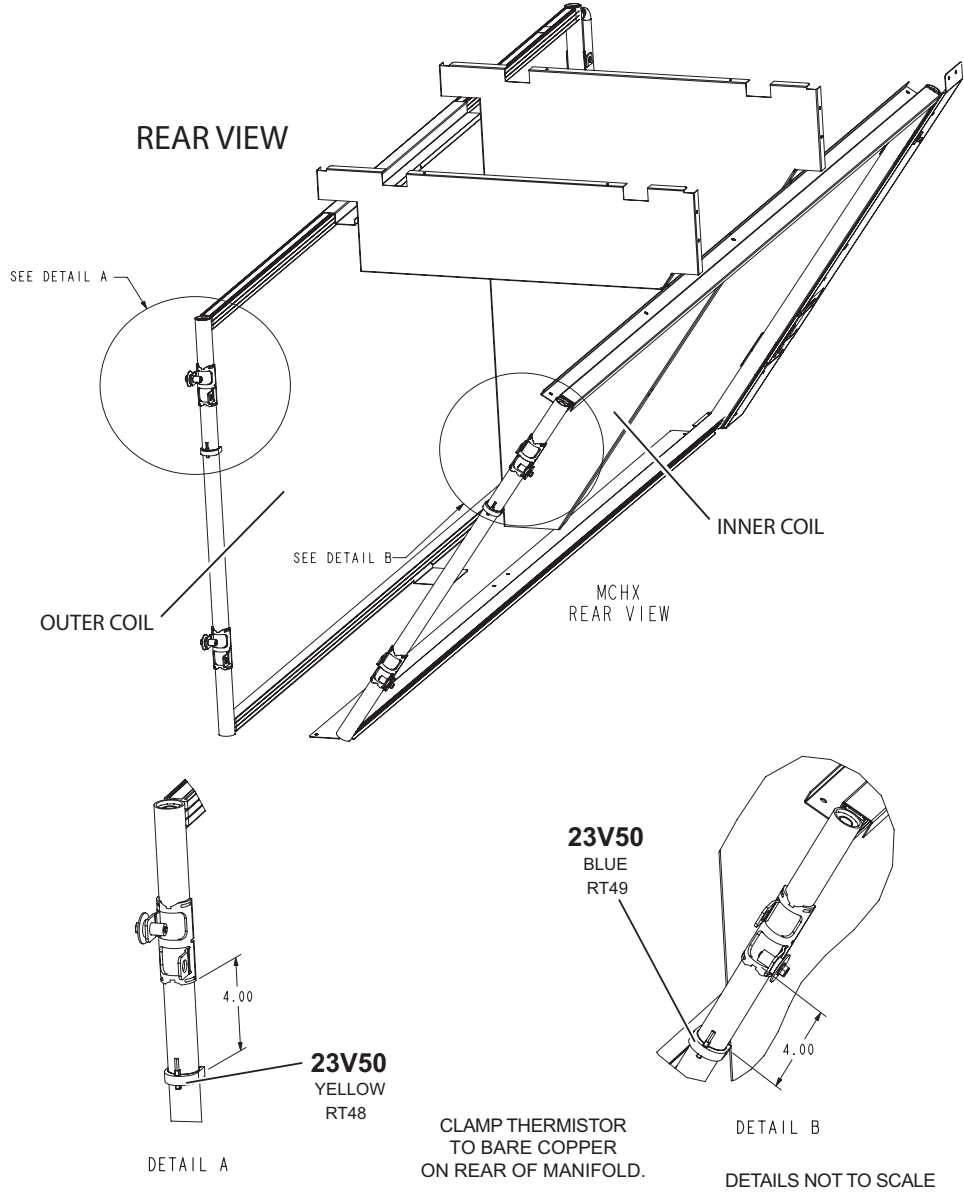

FIGURE 11

SGH/SCH240
EVAPORATOR COIL
(RT46, 47, 50, 51)

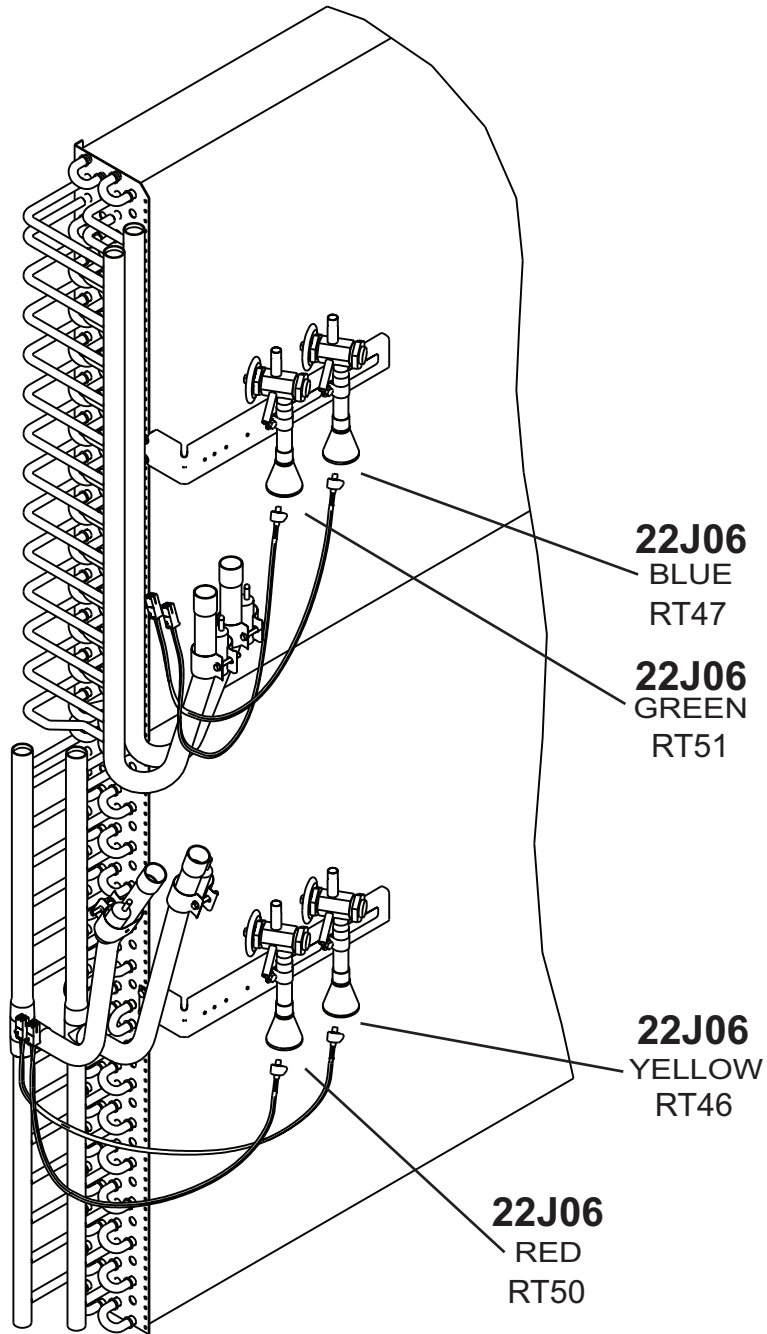
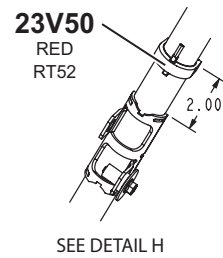
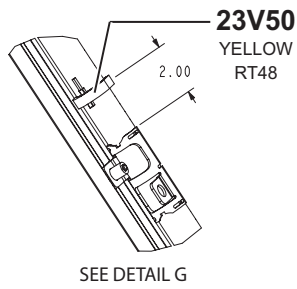
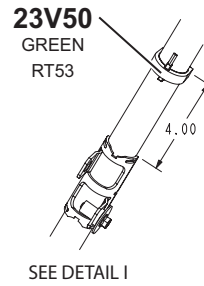
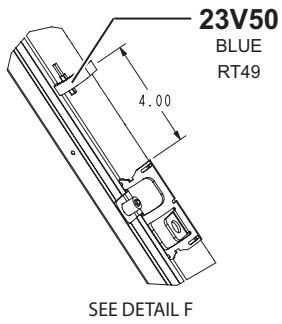
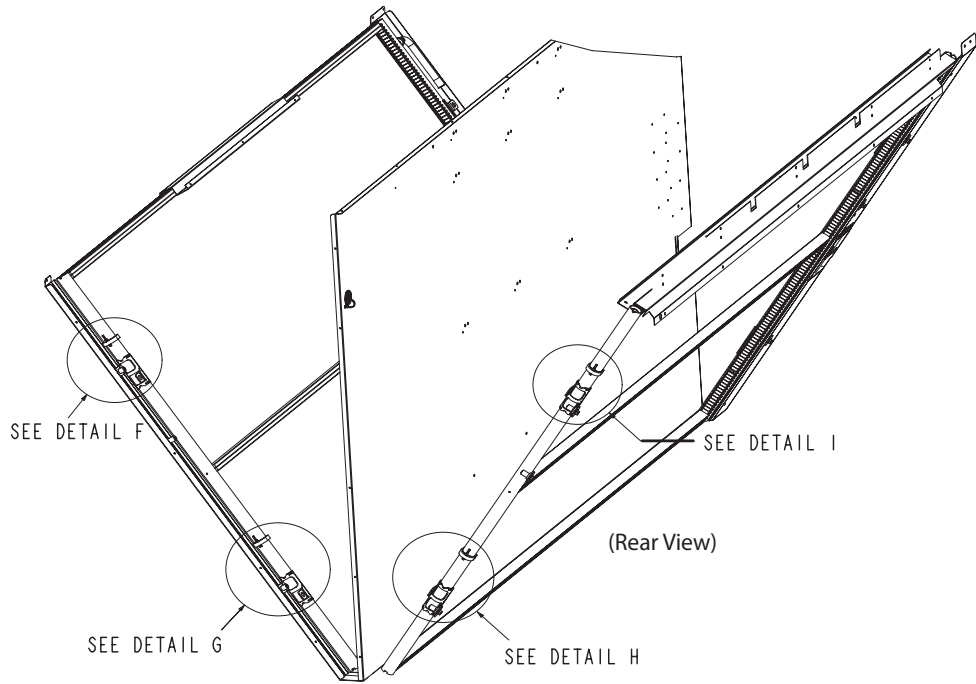

FIGURE 12

SGH/SCH240
CONDENSER COIL
RT48, 49, 52, 53



DETAILS NOT TO SCALE

FIGURE 13

9-RDS Sensors RT58, RT59

Units are equipped with factory-installed RDS Sensors located on different points on the unit. The RDS sensors provide the Unit Controller with continuous readings for leaked refrigerant concentration levels and sensor health status (Good or Fault). These readings are used to modify unit operation to disperse the leaked refrigerant and to remove possible ignition sources. In addition, the Unit Controller uses these readings to initiate alarms to alert the operator of a refrigerant leak or faulty sensor(s).

Each sensor must be specifically placed for proper unit operation and to initiate valid alarms. To identify sensor locations see TABLE 2.

TABLE 2
RDS Sensor Figures

Model	Qty.	Type	Figure
SGH120	2 sensors	INDOOR SENSOR	FIGURE 14
		COMPRESSOR SENSOR	FIGURE 15
SGH/ SCH240	2 sensors	INDOOR SENSOR	FIGURE 16
		COMPRESSOR SENSOR	FIGURE 17

The RDS Sensors and Controller shall only be replaced with parts specified by the appliance manufacturer.

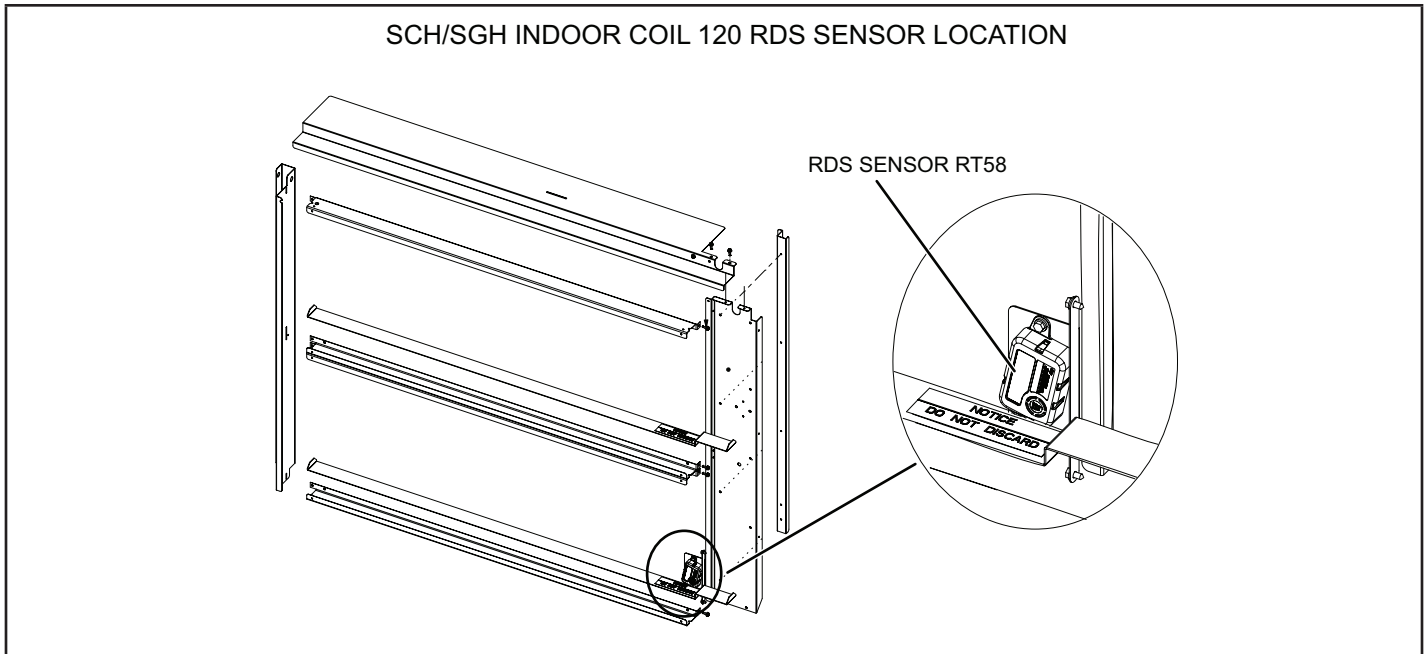

FIGURE 14

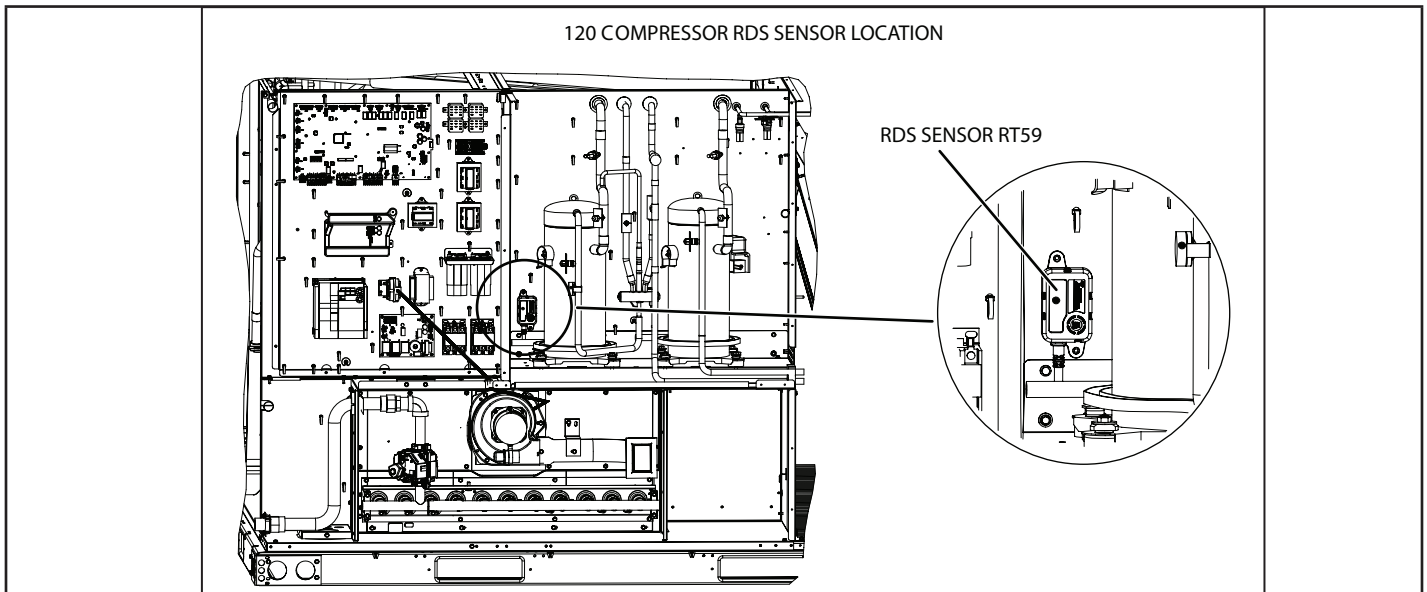

FIGURE 15

240 INDOOR COIL RDS SENSOR LOCATION

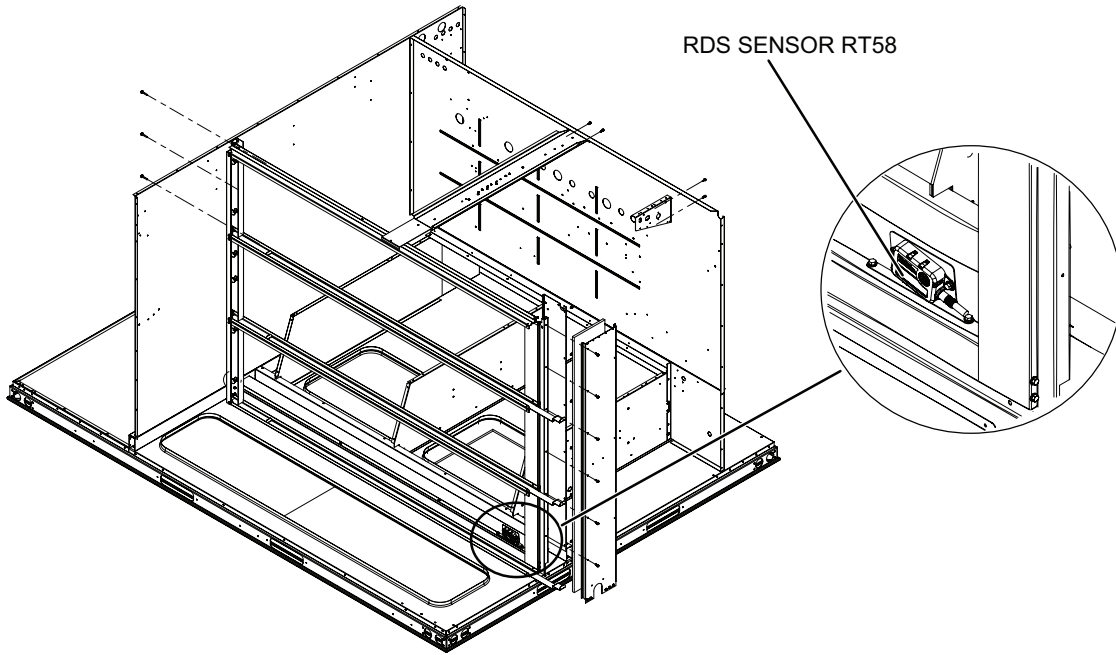

FIGURE 16

240 COMPRESSOR RDS SENSOR LOCATION

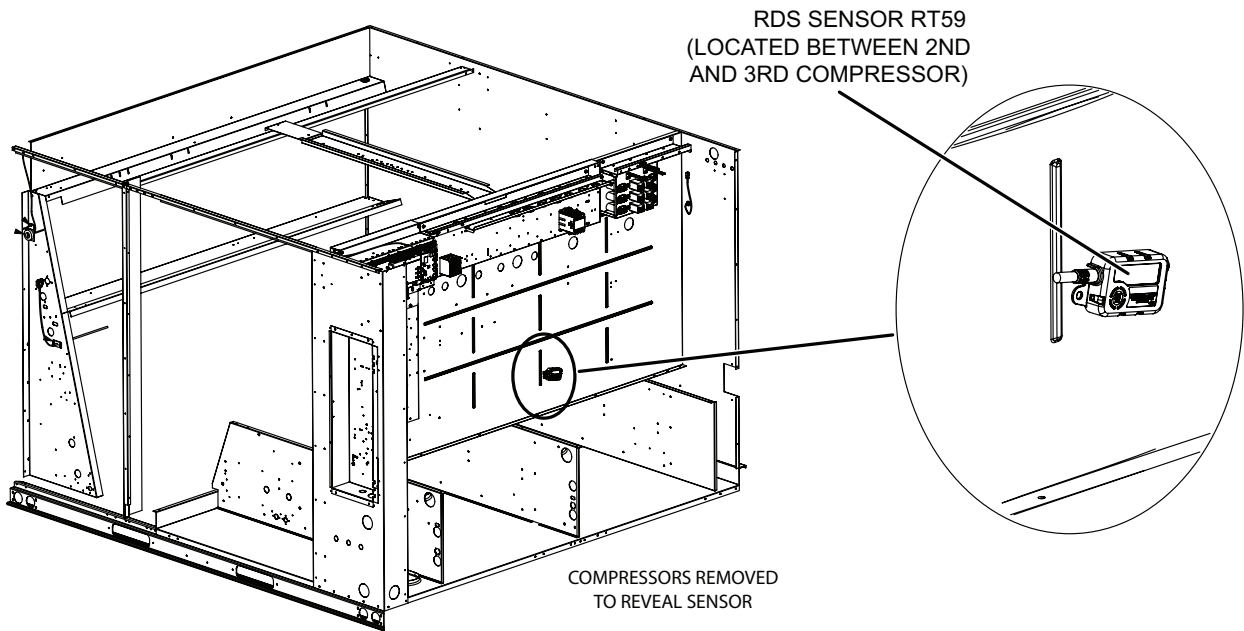

FIGURE 17

C-Blower Compartment

The blower compartment is located between the evaporator coil and the compressor / control section on the opposite side of the condenser coil. The blower assembly is accessed by disconnecting the blower motor wiring (and all other plugs) and removing the screws on either side of the sliding base. The base pulls out as shown in FIGURE 19 and FIGURE 20.

1-Blower Wheels

SCH120 units have one 15 in. x 15 in. blower wheels and SCH240 units have two 18 in x 15 in blower wheels. Blower wheels are driven by one motor.

2-Indoor Blower Motor B3

All units use three-phase single-speed blower motors. CFM adjustments are made by adjusting the motor pulley (sheave). Motors are equipped with sealed ball bearings. All motor specifications are listed in the SPECIFICATIONS (table of contents) in the front of this manual. Units may be equipped with motors manufactured by various manufacturers, therefore electrical FLA and LRA specifications will vary. See unit rating plate for information specific to your unit.

OPERATION / ADJUSTMENT

Belt Drive With Supply Air Inverter The blower rotation will always be correct on units equipped with an inverter or a direct drive blower. Checking blower rotation is not a valid method of determining voltage phasing for incoming power.

Belt Drive Blowers Controlled by an Inverter The Unit Controller checks the incoming power during start-up. If the voltage or phase is incorrect, the Unit Controller will display an alarm and the unit will not start.

Blower Operation

NOTE - On units with staged blowers, use the Unit Controller to start the blower. Refer to the appropriate start-up section.

Initiate blower demand at thermostat according to instructions provided with thermostat. Unit will cycle on thermostat demand. The following steps apply to applications using a typical electro-mechanical thermostat. MSAV™ units refer to the Optional Supply Air VFD section.

- 1 - Blower operation is manually set at the thermostat subbase fan switch. With fan switch in ON position, blowers will operate continuously.
- 2 - With fan switch in AUTO position, the blowers will cycle with demand. Blowers and entire unit will be off when system switch is in OFF position.

IMPORTANT

Three Phase Scroll Compressor Voltage Phasing

Three phase scroll compressors must be phased sequentially to ensure correct compressor and blower* rotation and operation. Compressor and blower are wired in phase at the factory. Power wires are color-coded as

follows: line 1-red, line 2-yellow, line 3-blue.

1-Observe suction and discharge pressures and blower* rotation on unit start-up.

2-Suction pressure must drop, discharge pressure must rise and blower* rotation must match rotation marking. If pressure differential is not observed or blower* rotation is not correct:

3-Disconnect all remote electrical power supplies.

4-Reverse any two field-installed wires connected to the line side of S48 disconnect or TB13 terminal strip. Do not reverse wires at blower contactor.

5-Make sure the connections are tight. Discharge and suction pressures should operate at their normal start-up ranges.

*Supply air inverter blower motors should rotate in the correct direction; verify scroll compressor rotation separately. Contact technical support if the blower is rotating incorrectly.

WARNING

1-Make sure that unit is installed in accordance with the installation instructions and applicable codes.

2-Inspect all electrical wiring, both field- and factory-installed, for loose connections. Tighten as required.

3-Check to ensure that refrigerant lines do not rub against the cabinet or against other refrigerant lines.

4-Check voltage at disconnect switch. Voltage must be within range listed on nameplate. If not, consult power company and have voltage condition corrected before starting unit.

5-Make sure filters are new and in place before start-up.

Determining Unit CFM (with wet coil)

Belt Drive Blowers Controlled by an Inverter

IMPORTANT - MSAV™ units are factory-set to run the blower at full speed when there is a blower (G) demand without a heating or cooling demand. Refer to the field-provided, design specified CFM for all modes of operation. Use the following procedure to adjust motor pulley to deliver the highest CFM called for in the design spec. See MSAV™ Start-Up section to set blower CFM for all modes once the motor pulley is set.

- 1 - Measure the indoor blower motor RPM. Air filters must be in place when measurements are taken.
- 2 - With all access panels in place, measure static pressure external to unit (from supply to return). Blower performance data is based on static pressure readings taken in locations shown in FIGURE 18. **NOTE** - Static pressure readings can vary if not taken where shown.

- 3 - Referring to BLOWER DATA (table of contents), use static pressure and RPM readings to determine unit CFM.
- 4 - The blower RPM can be adjusted at the motor pulley. Loosen Allen screw and turn adjustable pulley clockwise to increase CFM. Turn counterclockwise to decrease CFM. See FIGURE 19 and FIGURE 20. Do not exceed minimum and maximum number of pulley turns as shown in TABLE 3.

TABLE 3

Belt	Minimum Turns Open	Maximum Turns Open
A Section	0	5
B Section	1*	6

*No minimum number of turns open when B belt is used on pulleys 6-inch O.D. or larger.

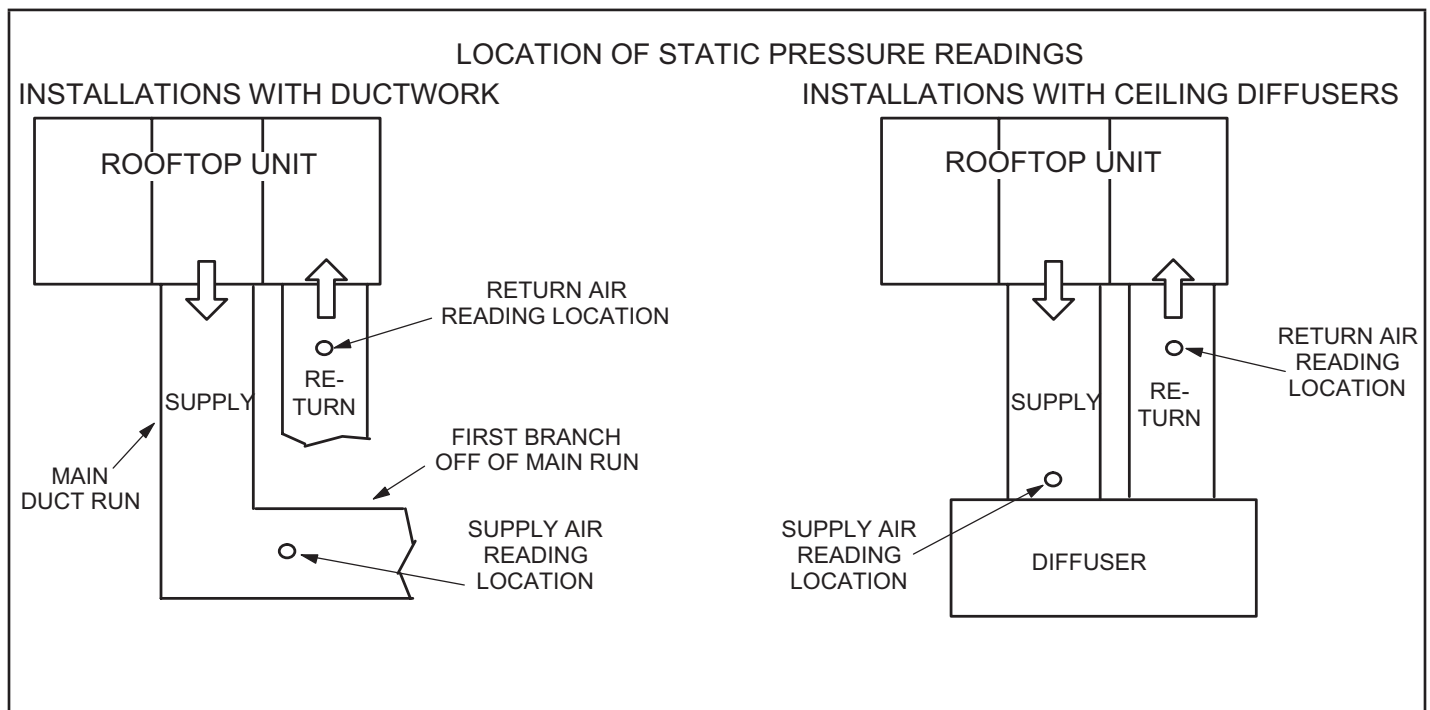

FIGURE 18

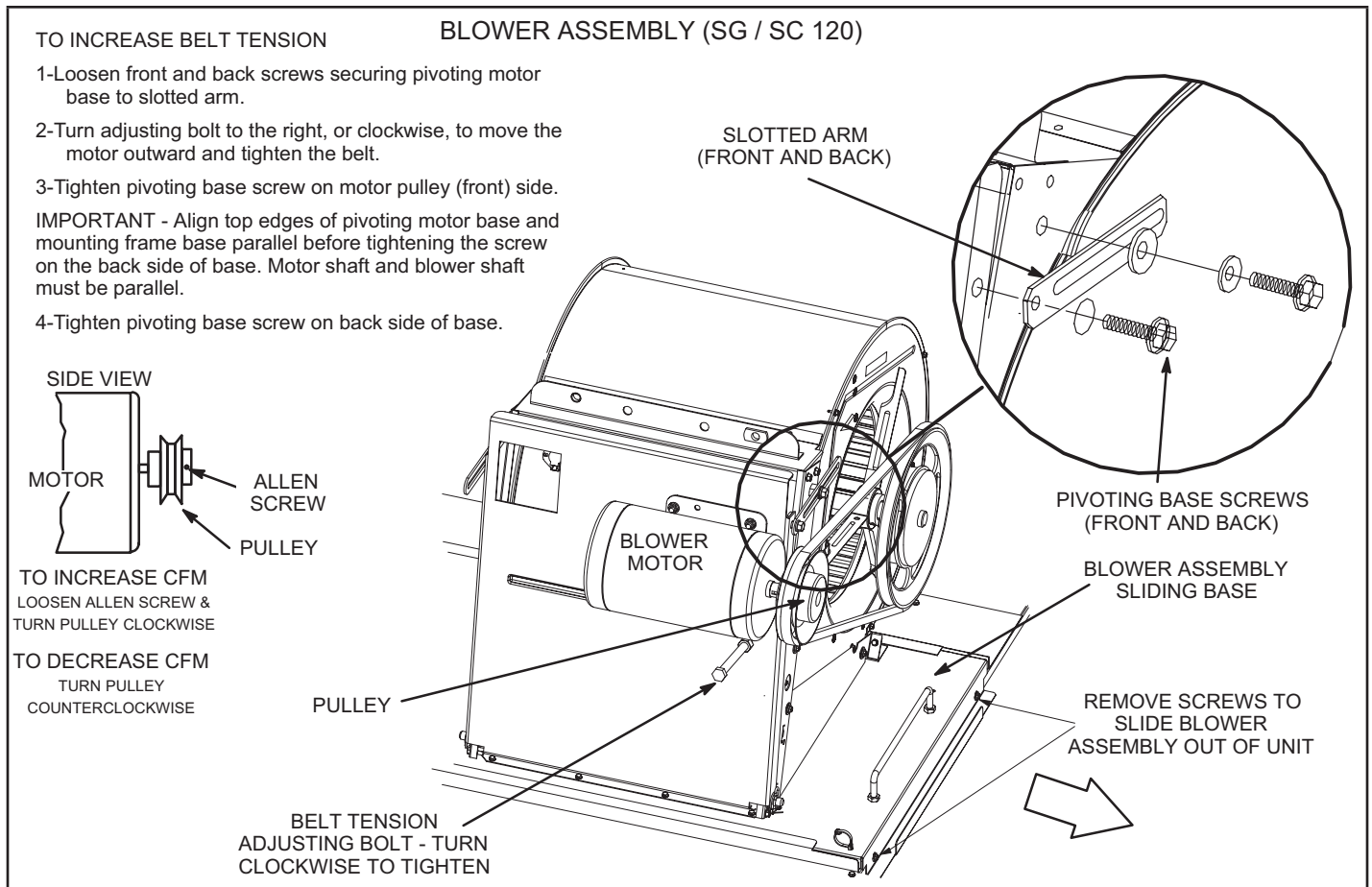

FIGURE 19

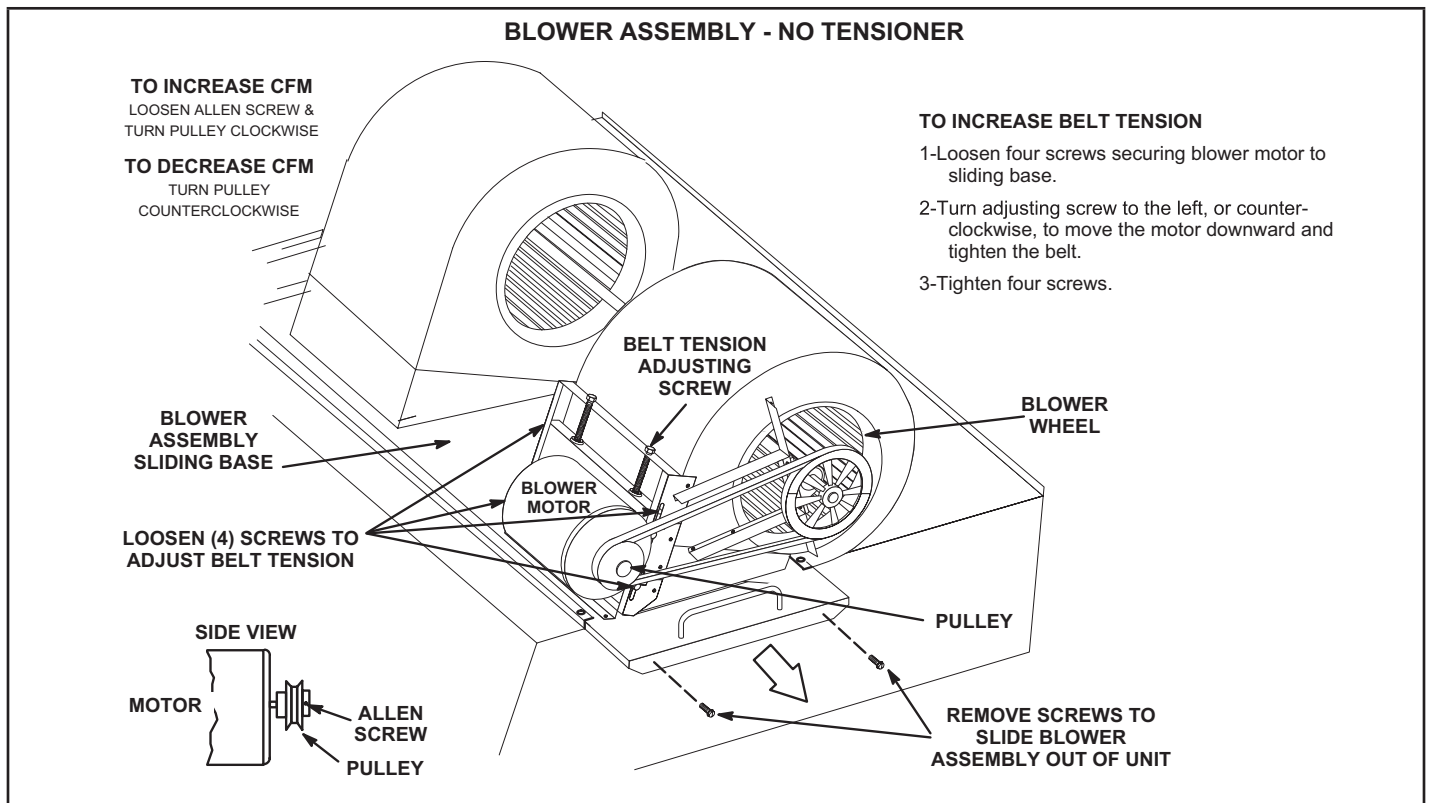

FIGURE 20

Adjust Belt Tension

Maximum life and wear can be obtained from belts only if proper pulley alignment and belt tension are maintained. Tension new belt after a 24-48 hour period of operation. This will allow belt to stretch and seat to grooves. Make sure blower and motor pulley are aligned as shown in FIGURE 21. See FIGURE 19 or FIGURE 20 to adjust belt tension.

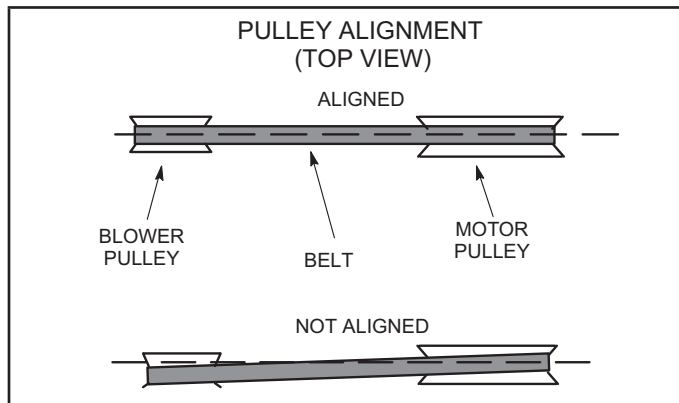

FIGURE 21

Check Belt Tension

Overtensioning belts shortens belt and bearing life. Check belt tension as follows:

- 1 - Measure span length (X). See FIGURE 22.
- 2 - Apply perpendicular force to center of span (X) with enough pressure to deflect belt 1/64" for every inch of span length or 0.4mm per 25.4mm of span length.

Example: Deflection distance of a 40" span would be 40/64" or 5/8".

Example: Deflection distance of a 1016mm span would be 16mm.

- 3 - Measure belt deflection force. The deflection force should be 7.0 lbs.

A force below these values indicates an undertensioned belt. A force above these values indicates an overtensioned belt.

Blower Drives

See BLOWER DATA (page 8) for blower drive table.

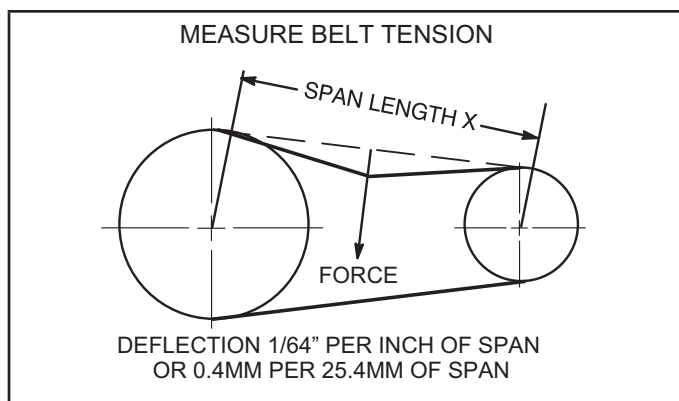

FIGURE 22

D-OPTIONAL ELECTRIC HEAT

See ELECTRICAL / ELECTRIC HEAT DATA and ELECTRIC HEAT CAPACITIES (table of contents) for SCH to EHA/EHB match-ups and electrical ratings.

EHA/EHB parts arrangement is shown in FIGURE 24 and FIGURE 25. All electric heat sections consist of electric heating elements exposed directly to the air stream. Two electric heat sections (first section and second section) are used in all 15kW through 90kW heaters. See FIGURE 23. Multiple-stage elements are sequenced on and off in response to thermostat demand.

The electric heat assembly is fixed in place with screws as shown in FIGURE 26 and FIGURE 27.

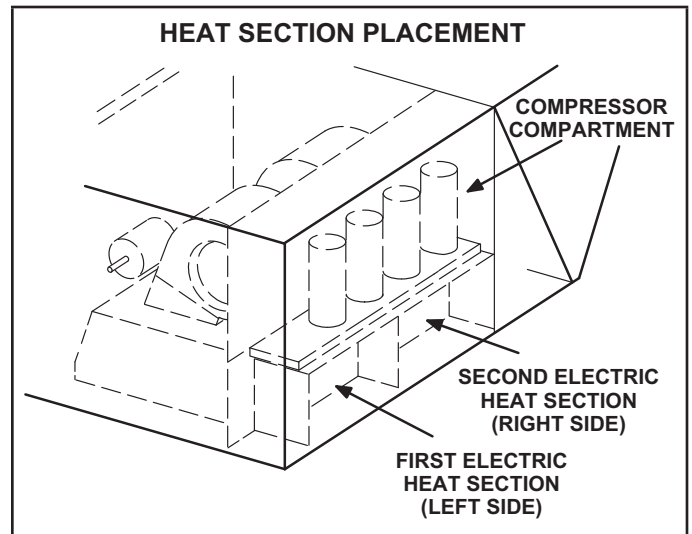

FIGURE 23

1-Main Control Box Components A55, K9

The main control box houses the A55 Unit Controller and the K9 electric heat relay.

2-Contactors K15, K16, FIGURE 26K17 and K18

Contactors K15, K16, K17 and K18 are all three-pole double-break contactors located on the electric heat vestibule. K15 and K16 are located on the first electric heat section, while K17 and K18 are located on the second electric heat section. However, in the 15 and 30kW heaters, the first section houses all contactors and fuses. All contactors are equipped with a 24VAC coil. The coils in the K15, K16, K17 and K18 contactors are energized by the main panel A55. Contactors K15 and K17 energize the first stage heating elements, while K16 and K18 energize the second stage heating elements.

3-High Temperature Limits S15 and S107 (Primary)

S15 and S107 are SPST N.C. auto-reset thermostats located on the back panel of the electric heat section below the heating elements. S15 is the high temperature limit for the first electric heat section, while S107 is the high temperature limit for the second electric heat section. Both thermostats are identical and are wired to the A55 Unit Controller. When either S15 or S107 opens, indicating a problem in the system, contactor K15 is de-energized. When K15 is de-energized, first stage and all subsequent stages of heat are de-energized. The thermostats used on EHA360-45-1 Y/G/J are factory set to open at $200F \pm 5F$ on a temperature rise and automatically reset at $160F \pm 6F$ on a temperature fall. All other electric heat section thermostats are factory set to open at $170F \pm 5F$ on a temperature rise and automatically reset at $130F \pm 6F$ on a temperature fall. The thermostats are not adjustable.

4-Terminal Strip TB3

Electric heat line voltage connections are made to terminal strip TB3 (or a fuse block on some models) located in the upper left corner of the electric heat vestibule.

5-Heating Elements HE1 through HE14

Heating elements are composed of helix wound bare nichrome wire exposed directly to the air stream. Three elements are connected in a three-phase arrangement. Elements are connected in "Wye" arrangement.

Each stage is energized independently by the corresponding contactors located on the electric heat vestibule panel. Once energized, heat transfer is instantaneous. High temperature protection is provided by primary and redundant high temperature limits and overcurrent protection is provided by fuses.

6-Fuse F3

Fuse F3 are housed in a fuse block which holds three fuses. Each F3 fuse is connected in series with each leg of electric heat. FIGURE 24, FIGURE 25 and TABLE 4 shows the fuses used with each electric heat section.

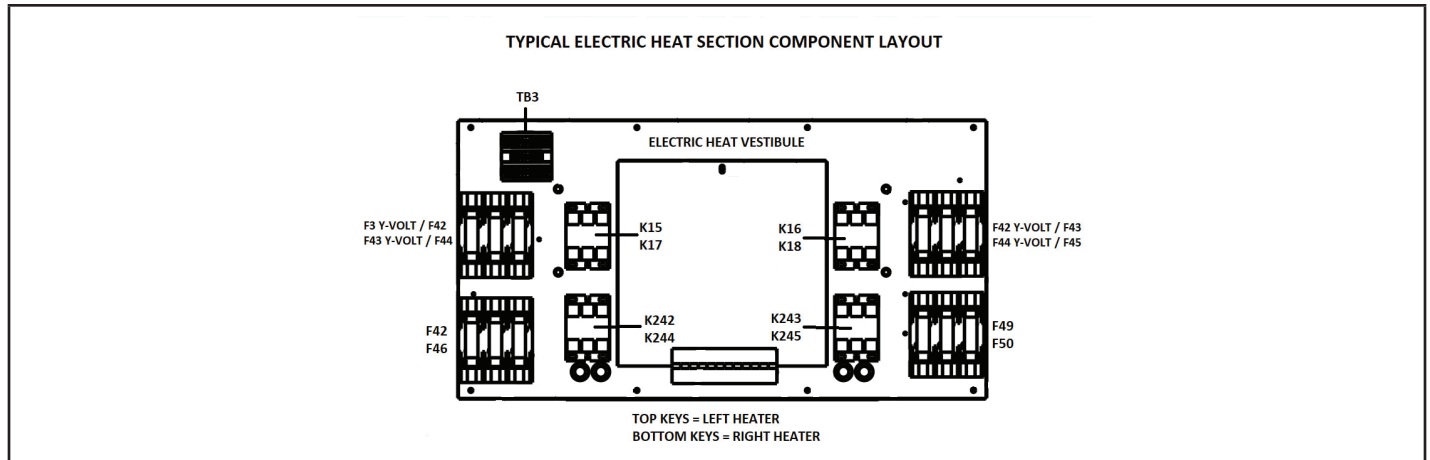

FIGURE 24

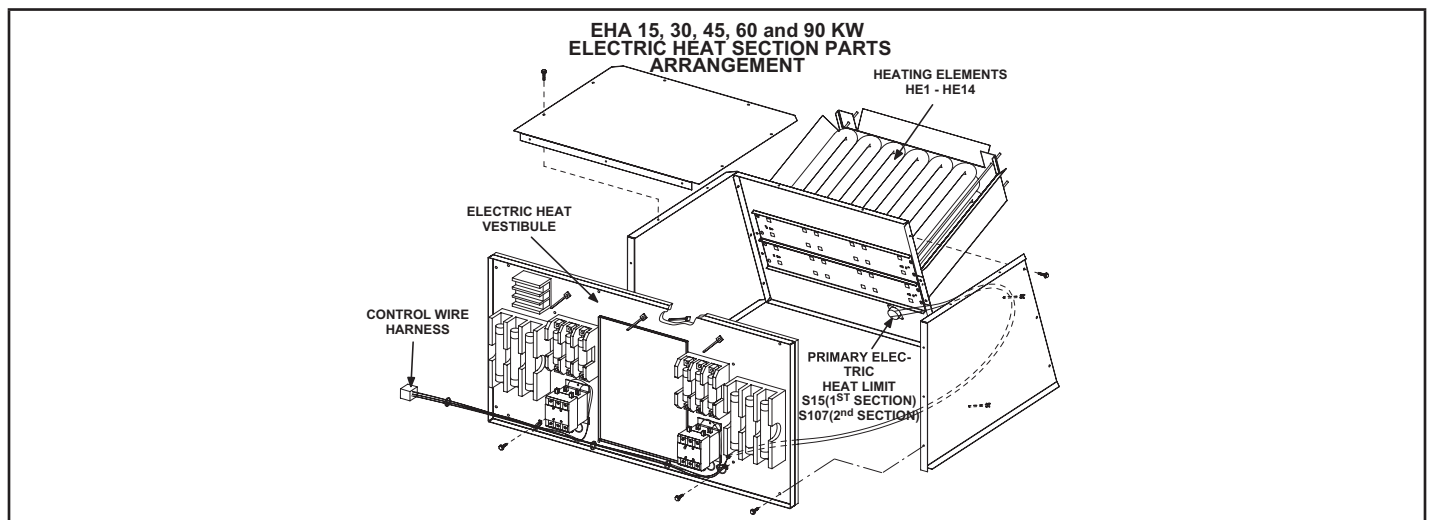

FIGURE 25

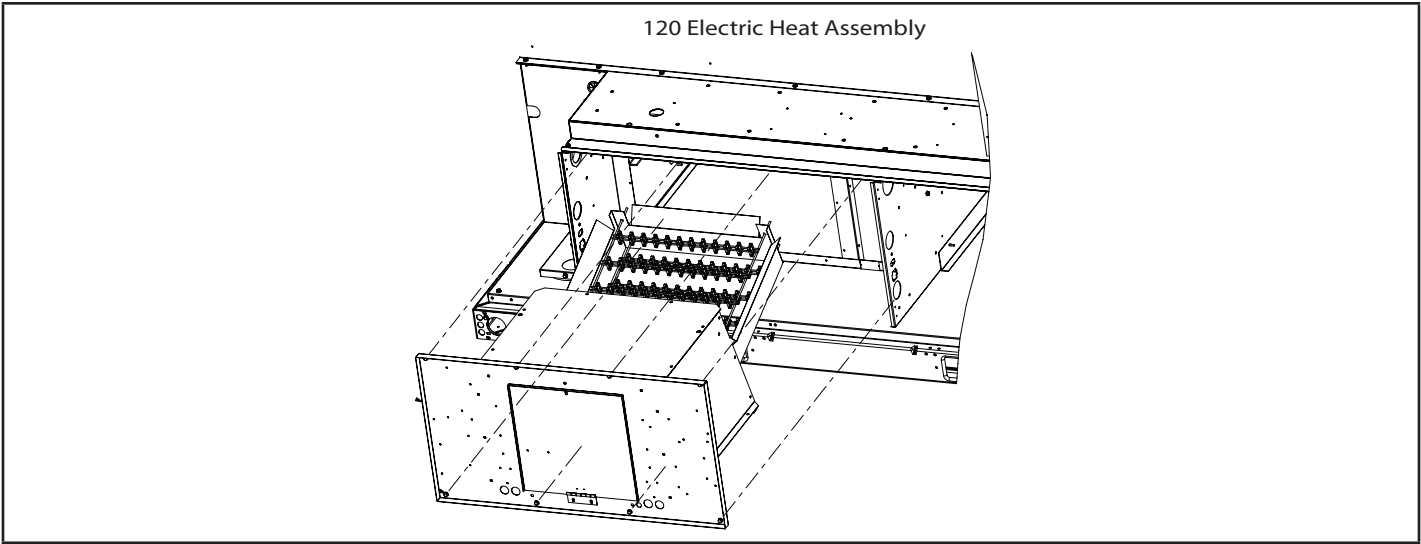

FIGURE 26

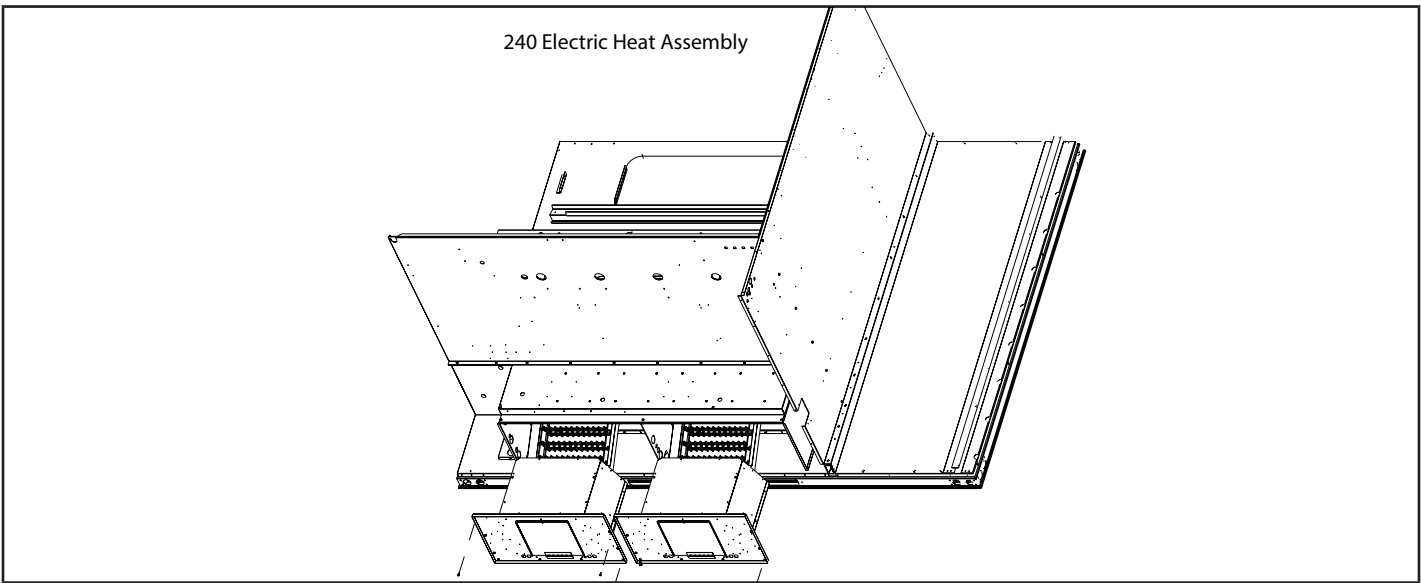

FIGURE 27

TABLE 4

ELECTRIC HEAT SECTION FUSE RATING				
EHA QUANTITY & SIZE	VOLTAGES	FUSE (3 each)		
		F3	F34	F344
(1)EHA360-15 LEFT (30 KW Total)	460V	50A 600V		
	575V	40A 600V		
(2) EHA150-30 (60 KW Total)	460V	25 600v		25A 600V
	575V	25A 600V		20A 600V
(2) EHA360-45 (90 KW Total)	460V	25A 600V		50A 600V
	575V	20A 600V		40A 600V
(1) EHB240-10 LEFT (20 KW Total)	460V		35A 600V	
(2) EHB240-20 (40 KW Total)	460V		15A 600V	15A600V
(2) EHB240-40 (80 KW Total)	460V		35A 600V	35A 600V

II-CHARGING

A-Refrigerant Charge and Check - All-Aluminum Coil

IMPORTANT - Charge unit in standard cooling mode.

WARNING-Do not exceed nameplate charge under any condition.

This unit is factory charged and should require no further adjustment. If the system requires additional refrigerant, reclaim the charge, evacuate the system, and add required nameplate charge.

Refrigerant Charge R-454B		
Unit	M _c (lbs)	M _c (kg)
SCH120 circ 1	7.00	3.18
SCH120 circ 2	4.81	2.18
SCH120 circ 1W/ Humidtrol	7.00	3.18
SCH120 circ2 W/ Humidtrol	5.13	2.32
SCH240 circ 1	6.69	3.03
SCH240 circ 2	6.06	2.75
SCH240 circ 3	5.06	2.30
SCH240 circ 4	5.19	2.35
SCH240 circ 1 W/ Humiditrol	7.75	3.52
SCH240 circ 2 W/ Humiditrol	7.19	3.26
SCH240 circ 3 W/ Humiditrol	5.31	2.41
SCH240 circ 4 W/ Humiditrol	5.38	2.44

When breaking into the refrigerant circuit to make repairs – or for any other purpose – conventional procedures shall be used. However, for flammable refrigerants it is important that best practice be followed and, since flammability is a consideration, the following procedure shall be adhered to:

- Safely remove refrigerant following local and national regulations,
- Evacuate the circuit,
- Purge the circuit with inert gas,
- Evacuate,
- Purge with inert gas,
- Open the circuit

The refrigerant charge shall be recovered into the correct recovery cylinders if venting is not allowed by local and national codes. For appliances containing flammable refrigerants, the system shall be purged with oxygen-free nitrogen to render the appliance safe for flammable refrigerants. This process might need to be repeated several times. Compressed air or oxygen shall not be used for purging refrigerant systems. Refrigerant purging shall be achieved by breaking the vacuum in the system with oxygen-free nitrogen and continuing to fill until the working pressure is achieved, then venting to atmosphere, and finally pulling down to a vacuum. This process shall be repeated until no refrigerant is within the system. When the final oxygen-free nitrogen charge is used, the system shall be vented down to atmospheric pressure to enable work to take place. Ensure that the outlet for the vacuum pump is not close to any potential ignition sources and that ventilation is available.

In addition to conventional charging procedures, the following requirements shall be followed.

- Ensure that contamination of different refrigerants does not occur when using charging equipment. Hoses or lines shall be as short as possible to minimize the amount of refrigerant contained in them.
- Cylinders shall be kept in an appropriate position according to the instructions.
- Ensure that the refrigerating unit is earthed prior to charging the system with refrigerant.
 - Label the system when charging is complete (if not already).
 - Extreme care shall be taken not to overfill the refrigerating unit.

Prior to recharging the system, it shall be pressure-tested with the appropriate purging gas. The system shall be leak-tested on completion of charging but prior to commissioning. A follow up leak test shall be carried out prior to leaving the site.

- When removing refrigerant from a system, either for servicing or decommissioning, it is recommended good practice that all refrigerants are removed safely. When transferring refrigerant into cylinders, ensure that only appropriate refrigerant recovery cylinders are employed. Ensure that the correct number of cylinders for holding the total system charge is available. All cylinders to be used are designated for the recovered refrigerant and labelled for that refrigerant (i. e. special cylinders for the recovery of refrigerant). Cylinders shall be complete with pressure-relief valve and associated shut-off valves in good working order. Empty recovery cylinders are evacuated and, if possible, cooled before recovery occurs.
- The recovery equipment shall be in good working order with a set of instructions concerning the equipment that is at hand and shall be suitable for the recovery of all appropriate refrigerants including, when applicable, flammable refrigerants. In addition, a set of calibrated weighing scales shall be available and in good working order. Hoses shall be complete with leak-free disconnect couplings and in good condition. Before using the recovery machine, check that it is in satisfactory working order, has been properly maintained and that any associated electrical components are sealed to prevent ignition in the event of a refrigerant release. Consult manufacturer if in doubt.
- The recovered refrigerant shall be returned to the refrigerant supplier in the correct recovery cylinder, and the relevant waste transfer note arranged. Do not mix refrigerants in recovery units and especially not in cylinders.

- If compressors or compressor oils are to be removed, ensure that they have been evacuated to an acceptable level to make certain that flammable refrigerant does not remain within the lubricant. The evacuation process shall be carried out prior to returning the compressor to the suppliers. Only electric heating to the compressor body shall be employed to accelerate this process. When oil is drained from a system, it shall be carried out safely.

Prior to recharging the system, it shall be pressure-tested with the appropriate purging gas. The system shall be leak-tested on completion of charging but prior to commissioning. A follow up leak test shall be carried out prior to leaving the site

NOTE - *System charging is not recommended below 60F (15C). In temperatures below 60F (15C), the charge must be weighed into the system.*

If weighing facilities are not available, or to check the charge, use the following procedure:

- 1 - Make sure outdoor coil is clean. Attach gauge manifolds and operate unit at full CFM in cooling mode with economizer disabled until system stabilizes (approximately five minutes). Make sure all outdoor air dampers are closed.
- 2 - Compare the normal operating pressures to the pressures obtained from the gauges. Check unit components if there are significant differences.
- 3 - Measure the outdoor ambient temperature and the suction pressure. Refer to the charging curve to determine a target liquid temperature.

Note - *Pressures are listed for sea level applications.*

- 4 - Use the same thermometer to accurately measure the liquid temperature (in the outdoor section).
 - If measured liquid temperature is higher than the target liquid temperature, add refrigerant to the system.
 - If measured liquid temperature is lower than the target liquid temperature, recover some refrigerant from the system.
 - When transferring refrigerant into cylinders, ensure that only appropriate refrigerant recovery cylinders are employed. Ensure that the correct number of cylinders for holding the total system charge is available. All cylinders to be used are designated for the recovered refrigerant and labelled for that refrigerant (i. e. special cylinders for the recovery of refrigerant). Cylinders shall be complete with pressure-relief valve and associated shut-off valves in good working order. Empty recovery cylinders are evacuated and, if possible, cooled before recovery occurs.

- The recovery equipment shall be in good working order with a set of instructions concerning the equipment that is at hand and shall be suitable for the recovery of all appropriate refrigerants including, when applicable, flammable refrigerants. In addition, a set of calibrated weighing scales shall be available and in good working order. Hoses shall be complete with leak-free disconnect couplings and in good condition. Before using the recovery machine, check that it is in satisfactory working order, has been properly maintained and that any associated electrical components are sealed to prevent ignition in the event of a refrigerant release. Consult manufacturer if in doubt.
 - The recovered refrigerant shall be returned to the refrigerant supplier in the correct recovery cylinder, and the relevant waste transfer note arranged. Do not mix refrigerants in recovery units and especially not in cylinders.
 - If compressors or compressor oils are to be removed, ensure that they have been evacuated to an acceptable level to make certain that flammable refrigerant does not remain within the lubricant. The evacuation process shall be carried out prior to returning the compressor to the suppliers. Only electric heating to the compressor body shall be employed to accelerate this process. When oil is drained from a system, it shall be carried out safely.
- 5 - Add or remove charge in increments. Allow the system to stabilize each time refrigerant is added or removed.
 - 6 - Continue the process until measured liquid temperature agrees with the target liquid temperature. Do not go below the target liquid temperature when adjusting charge. Note that suction pressure can change as charge is adjusted.
 - 7 - Example: At 95°F outdoor ambient and a measured suction pressure of 130psig, the target liquid temperature is 97°F. For a measured liquid temperature of 106°F, add charge in increments until measured liquid temperature agrees with the target liquid temperature.

TABLE 5												
SG/SC 120 Normal Operating Pressures - No Reheat 581197-01												
	Outdoor Coil Entering Air Temperature											
	65°F		75°F		85°F		95°F		105°F		115°F	
	Suct (psig)	Disc (psig)	Suct (psig)	Disc (psig)	Suct (psig)	Disc (psig)	Suct (psig)	Disc (psig)	Suct (psig)	Disc (psig)	Suct (psig)	Disc (psig)
Circuit 1	104	220	106	259	108	304	109	356	111	415	112	480
	112	222	114	259	116	303	118	353	119	410	121	474
	127	229	130	263	133	304	135	351	138	405	141	465
	144	242	148	273	151	310	155	355	158	405	161	462
Circuit 2	106	242	107	279	108	321	109	366	110	415	111	469
	114	245	115	282	116	324	117	369	119	419	120	472
	129	252	131	290	133	332	135	377	137	427	139	480
	146	261	149	299	151	341	154	386	156	436	159	489

TABLE 6												
SG/SC 120 Normal Operating Pressures - Reheat - 581283-01												
	Outdoor Coil Entering Air Temperature											
	65°F		75°F		85°F		95°F		105°F		115°F	
	Suct (psig)	Disc (psig)	Suct (psig)	Disc (psig)	Suct (psig)	Disc (psig)	Suct (psig)	Disc (psig)	Suct (psig)	Disc (psig)	Suct (psig)	Disc (psig)
Circuit 1	100	230	101	269	102	314	103	367	104	426	105	493
	108	232	109	268	111	312	112	363	113	420	115	485
	124	239	127	272	129	312	131	359	133	413	135	474
	142	254	145	283	148	320	150	363	153	413	156	471
Circuit 2	103	236	104	272	105	312	106	358	106	408	107	462
	110	239	111	275	113	315	114	361	115	411	117	465
	126	246	128	282	130	323	132	368	134	418	136	473
	143	256	145	292	148	333	151	378	153	428	156	483

SC/SG 120 - No Reheat - Circuit 1

OD Temp (°F)

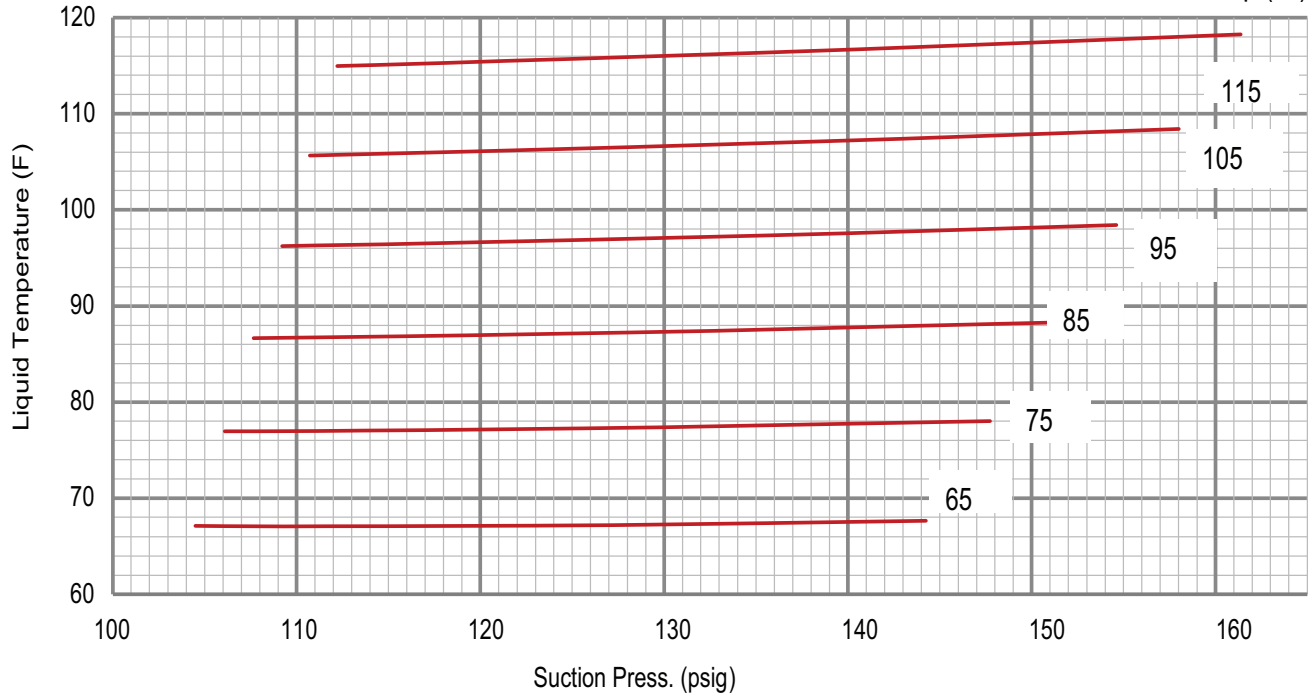

SG/SC 120 - No Reheat - Circuit 2

OD Temp (°F)

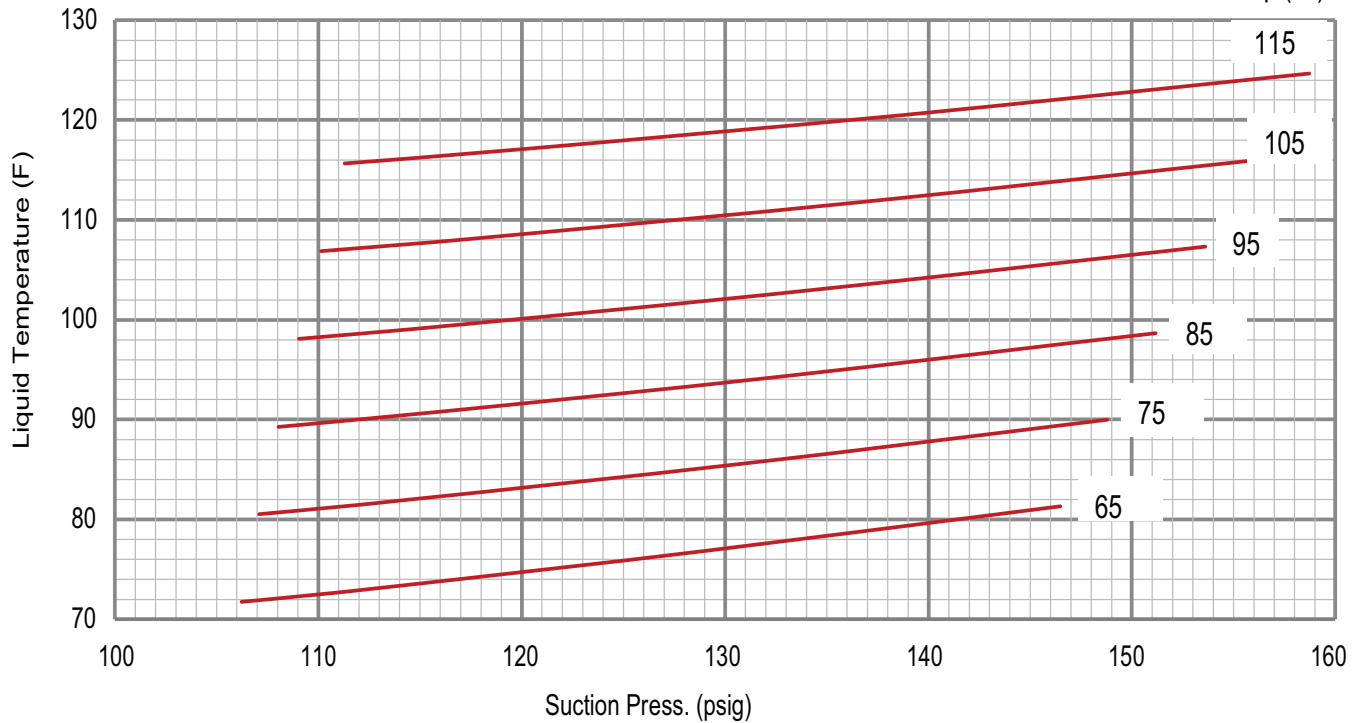

SG/SC 120 - Reheat - Circuit 1

OD Temp (°F)

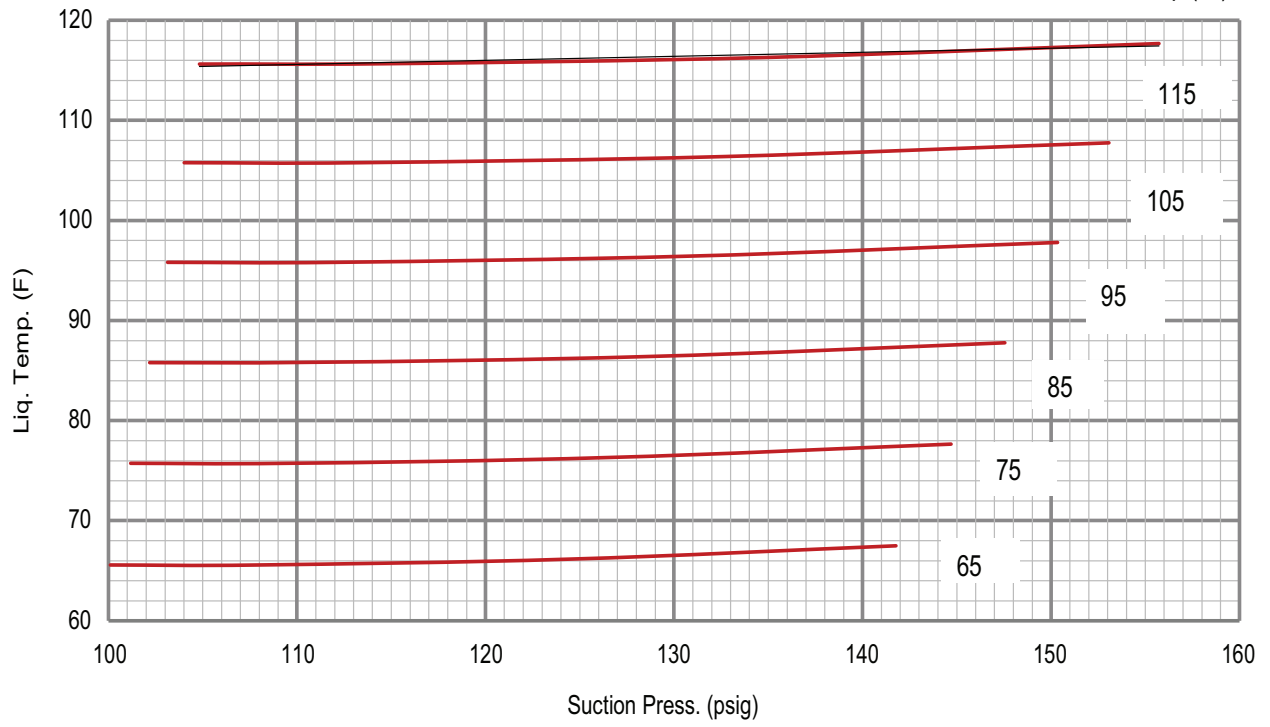

SG/SC 120 - Reheat - Circuit 2

OD Temp (°F)

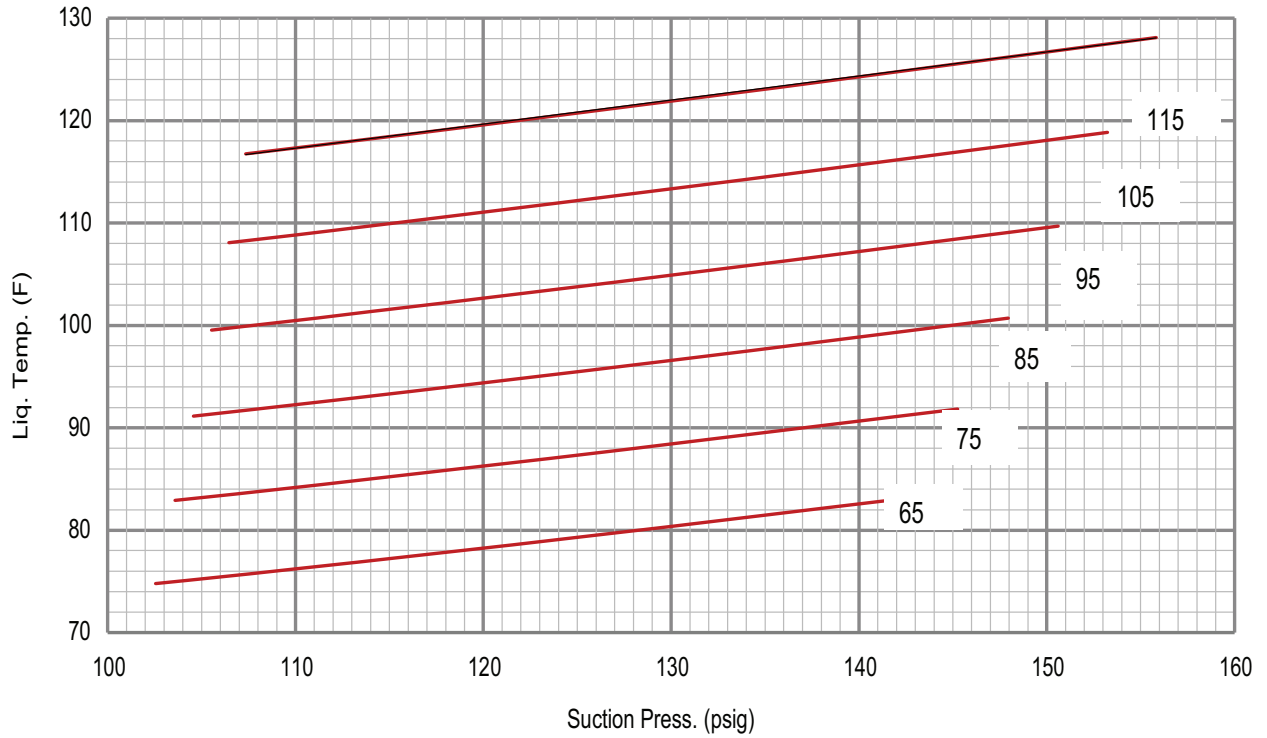
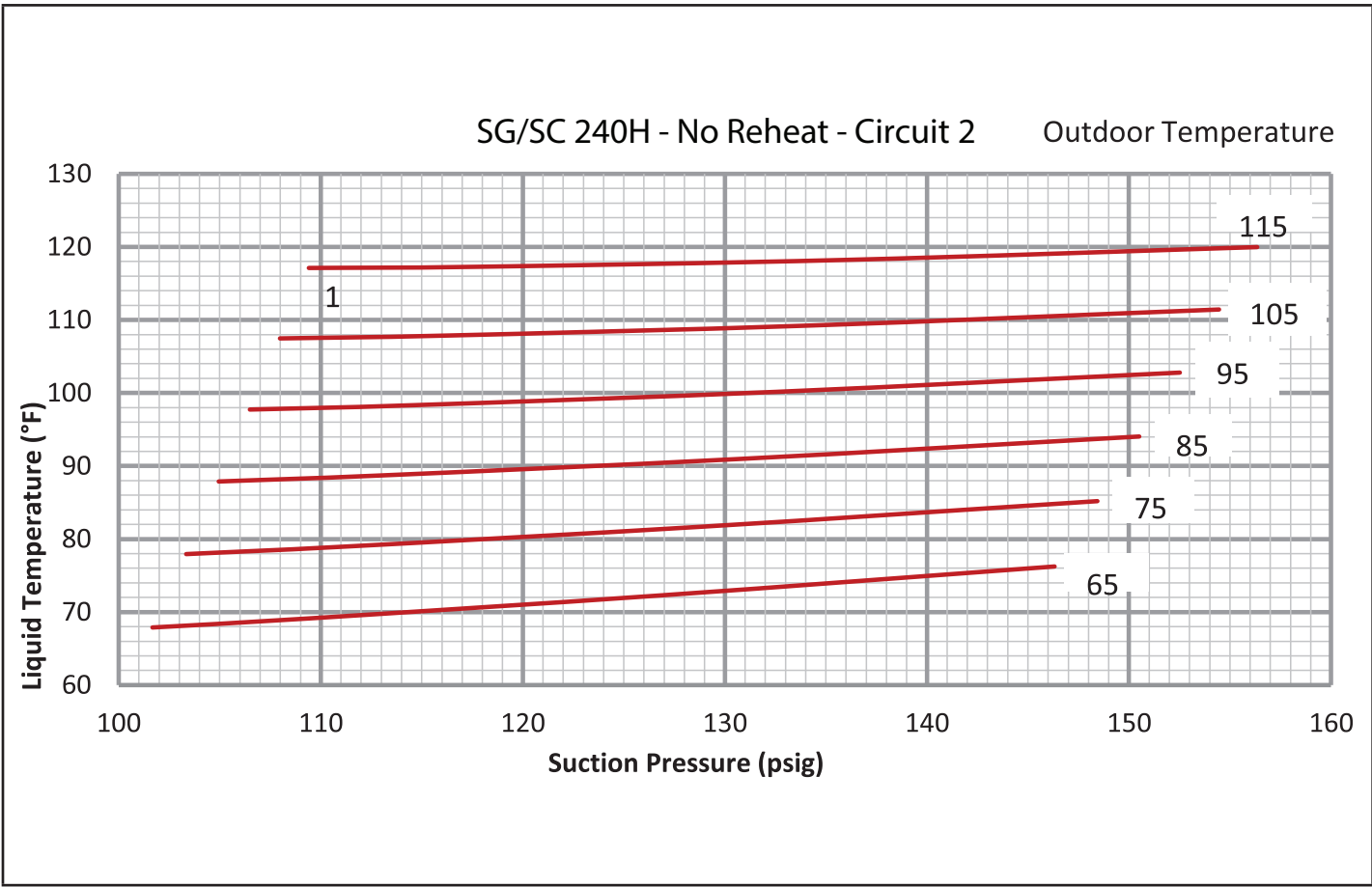
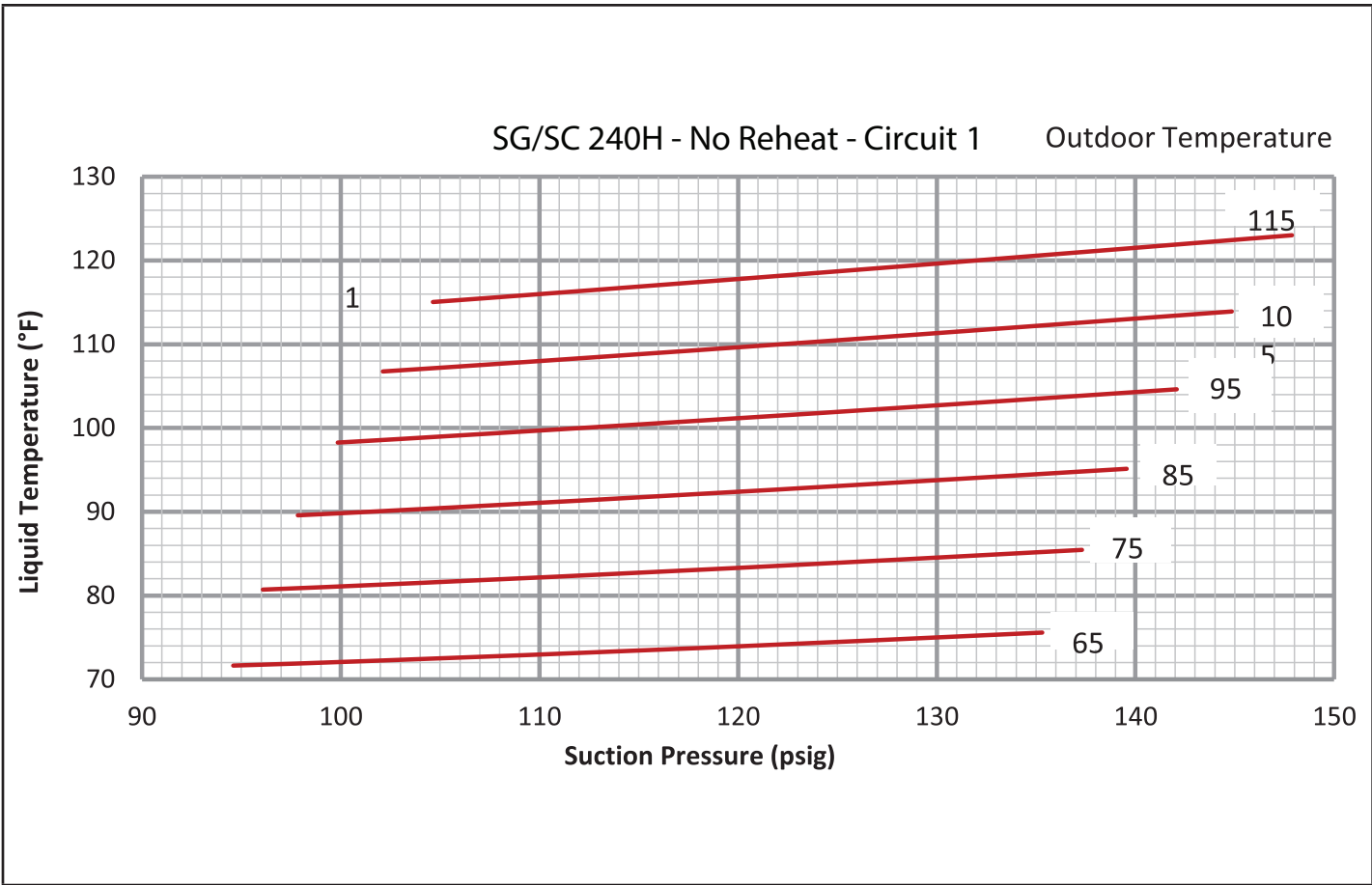

TABLE 7

SG/SC240 Normal Operating Pressures - No Reheat - 581198-01												
Outdoor Coil Entering Air Temperature												
65°F		75°F		85°F		95°F		105°F		115°F		
Suct (psig)	Disc (psig)	Suct (psig)	Disc (psig)	Suct (psig)	Disc (psig)	Suct (psig)	Disc (psig)	Suct (psig)	Disc (psig)	Suct (psig)	Disc (psig)	
Circuit 1	95	216	96	251	98	290	100	335	102	384	105	438
	102	218	104	253	106	293	108	337	110	387	113	441
	118	224	120	259	122	299	124	344	127	393	130	447
	135	232	137	267	140	306	142	351	145	401	148	455
Circuit 2	102	214	103	249	105	289	106	334	108	385	109	441
	110	216	111	251	113	291	115	336	116	387	118	443
	127	220	129	255	131	295	133	340	134	391	136	446
	146	225	148	260	151	300	153	345	154	395	156	451
Circuit 3	104	223	105	260	107	300	108	344	110	392	112	444
	111	226	113	263	114	303	116	348	118	396	120	448
	127	233	129	270	131	310	133	355	135	403	137	455
	145	241	147	278	149	318	151	363	154	412	156	464
Circuit 4	101	217	102	252	104	292	106	336	107	385	109	438
	108	219	110	255	112	295	114	339	116	387	118	440
	125	225	127	260	129	300	131	344	134	393	136	445
	145	231	147	267	149	307	151	351	154	399	156	452

TABLE 8

SG/SC 240 Normal Operating Pressures - Reheat - 581200-01												
Outdoor Coil Entering Air Temperature												
65°F		75°F		85°F		95°F		105°F		115°F		
Suct (psig)	Disc (psig)	Suct (psig)	Disc (psig)	Suct (psig)	Disc (psig)	Suct (psig)	Disc (psig)	Suct (psig)	Disc (psig)	Suct (psig)	Disc (psig)	
Circuit 1	96	231	99	268	101	310	104	358	106	410	109	468
	105	233	107	270	109	311	112	358	115	410	118	468
	122	240	124	276	127	316	129	362	132	413	135	469
	141	251	143	286	146	325	148	370	151	420	154	475
Circuit 2	98	224	101	260	103	300	106	346	109	397	112	453
	106	227	109	262	111	303	114	348	117	399	120	455
	125	234	127	269	129	309	131	354	133	404	136	459
	146	241	147	275	149	315	151	360	153	410	155	464
Circuit 3	100	227	102	264	104	306	107	351	110	401	112	456
	107	231	109	268	111	309	114	355	116	405	119	459
	124	238	126	275	128	316	130	362	132	412	135	466
	144	245	145	282	147	324	149	369	151	419	153	473
Circuit 4	102	225	103	261	105	301	107	346	110	396	113	450
	110	227	111	263	113	303	115	348	118	398	120	452
	128	232	129	268	130	309	132	354	134	404	137	458
	148	240	149	276	150	317	152	362	154	412	156	466



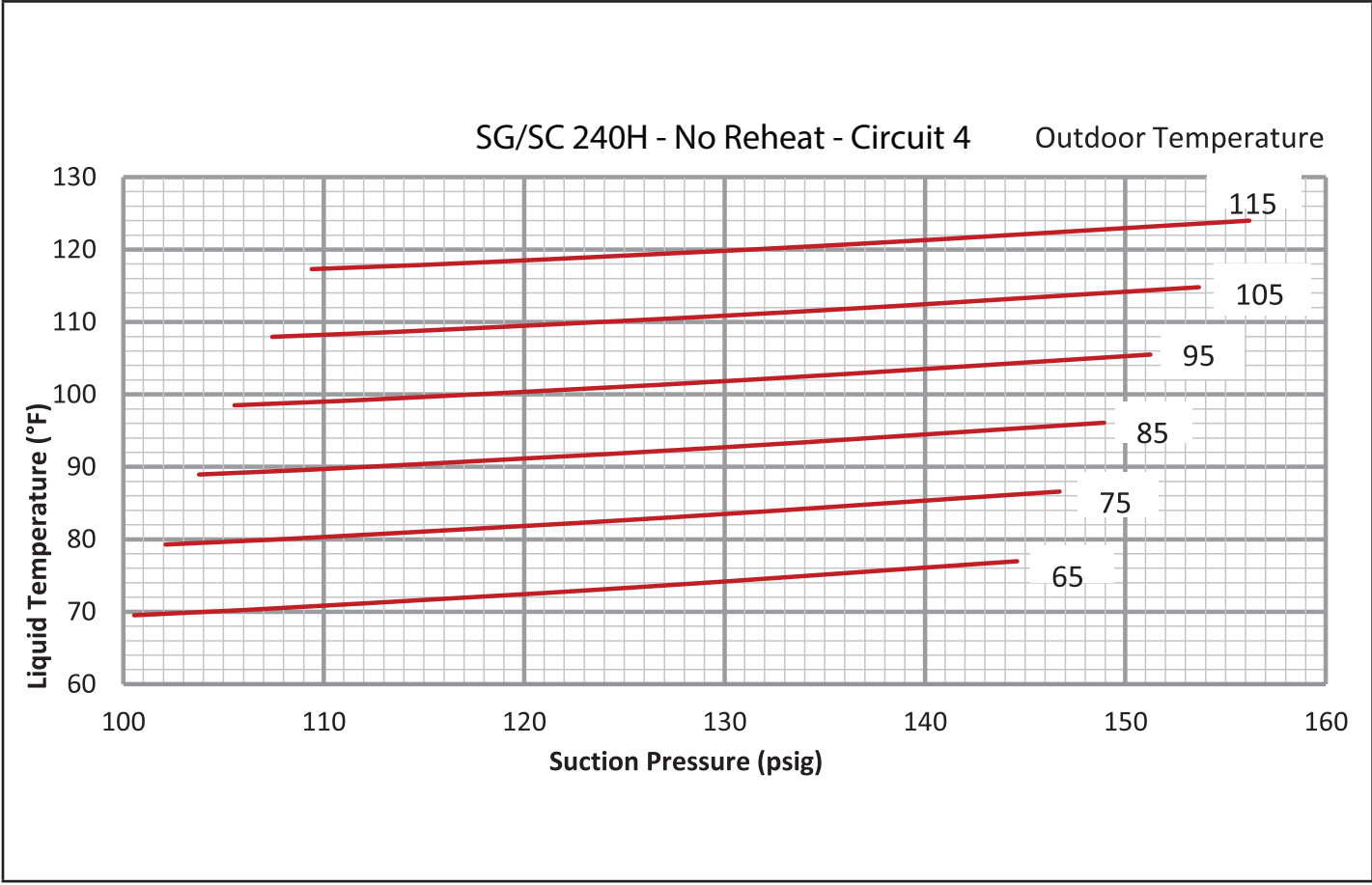
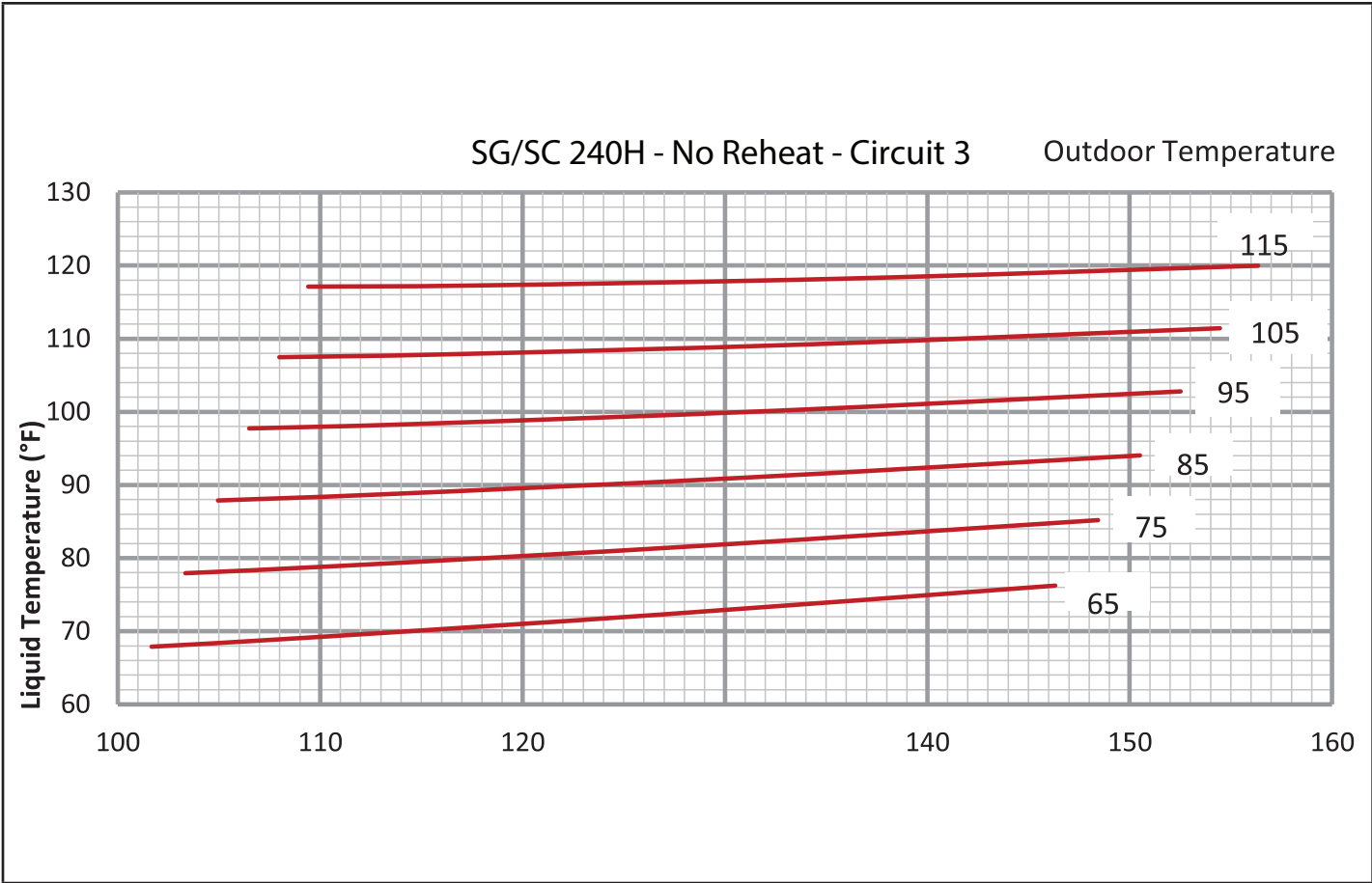

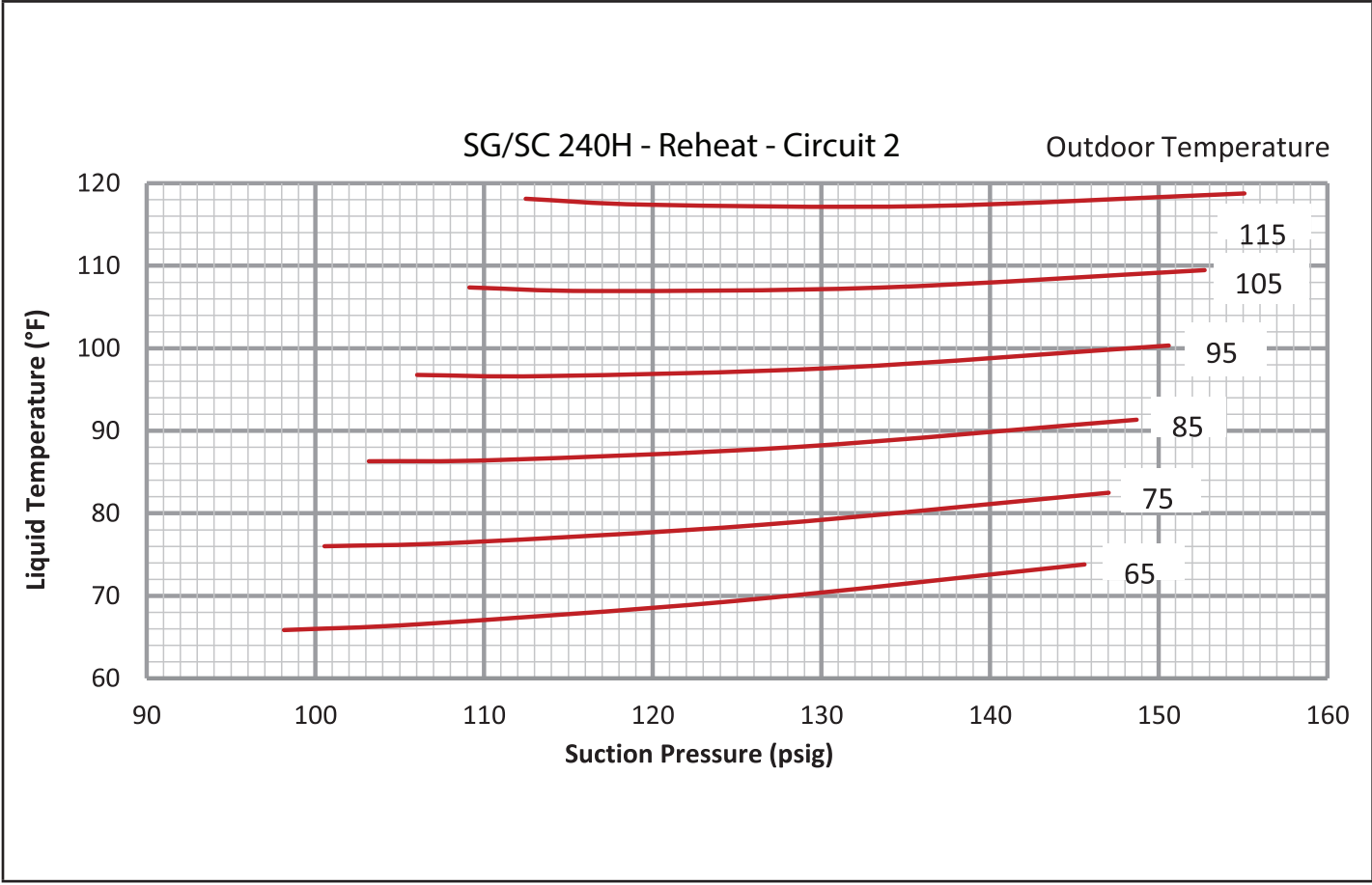
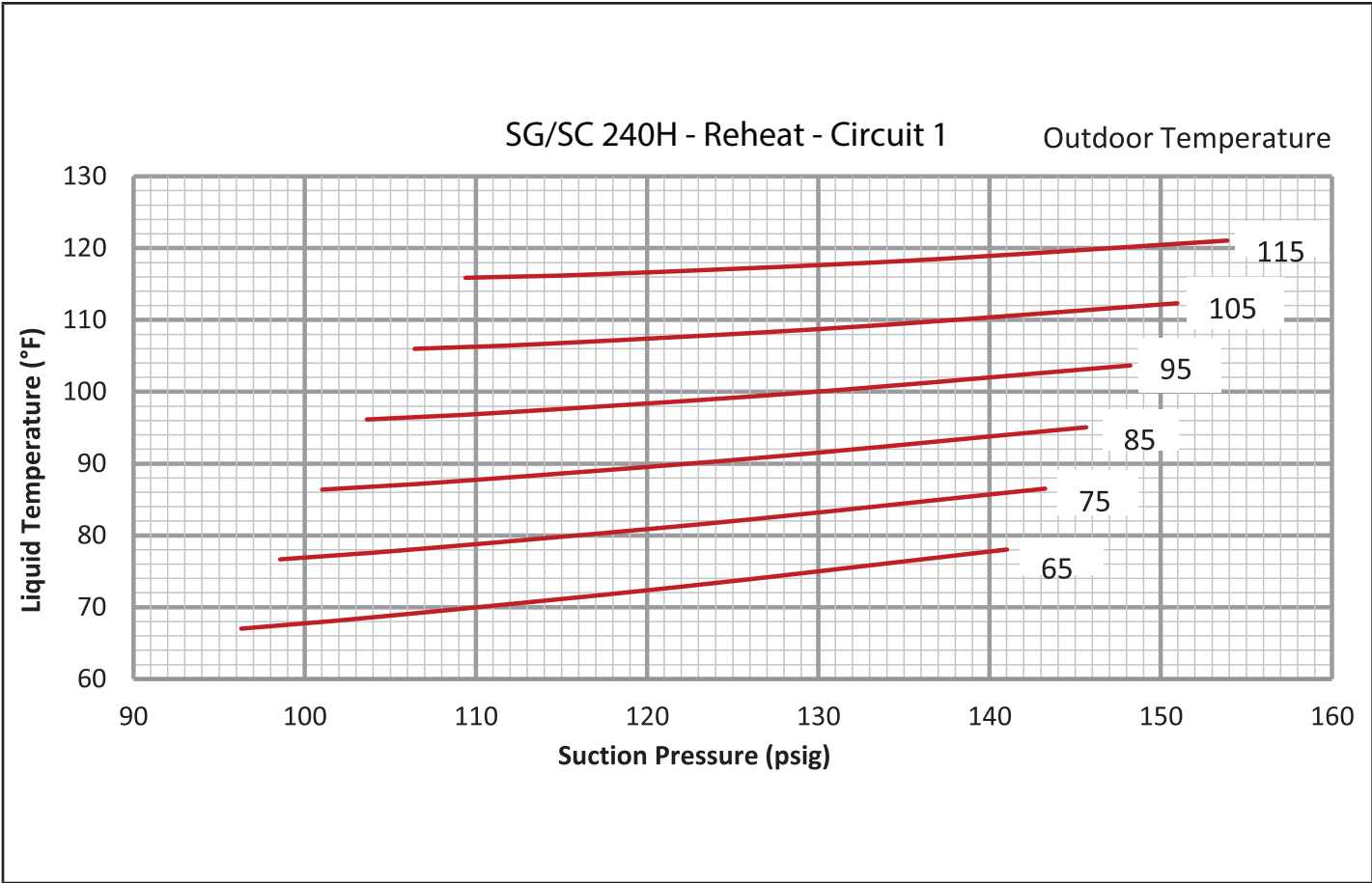

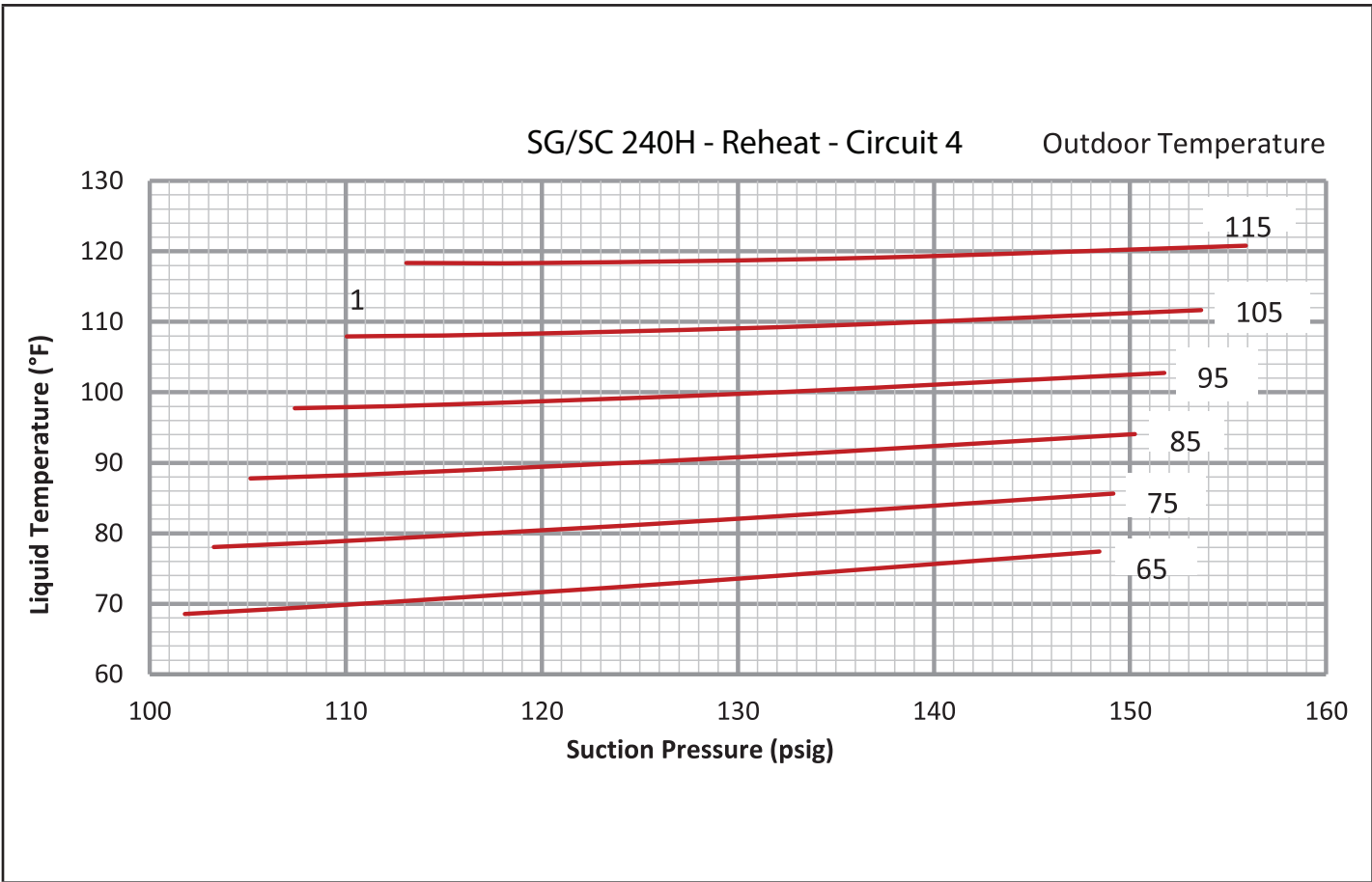
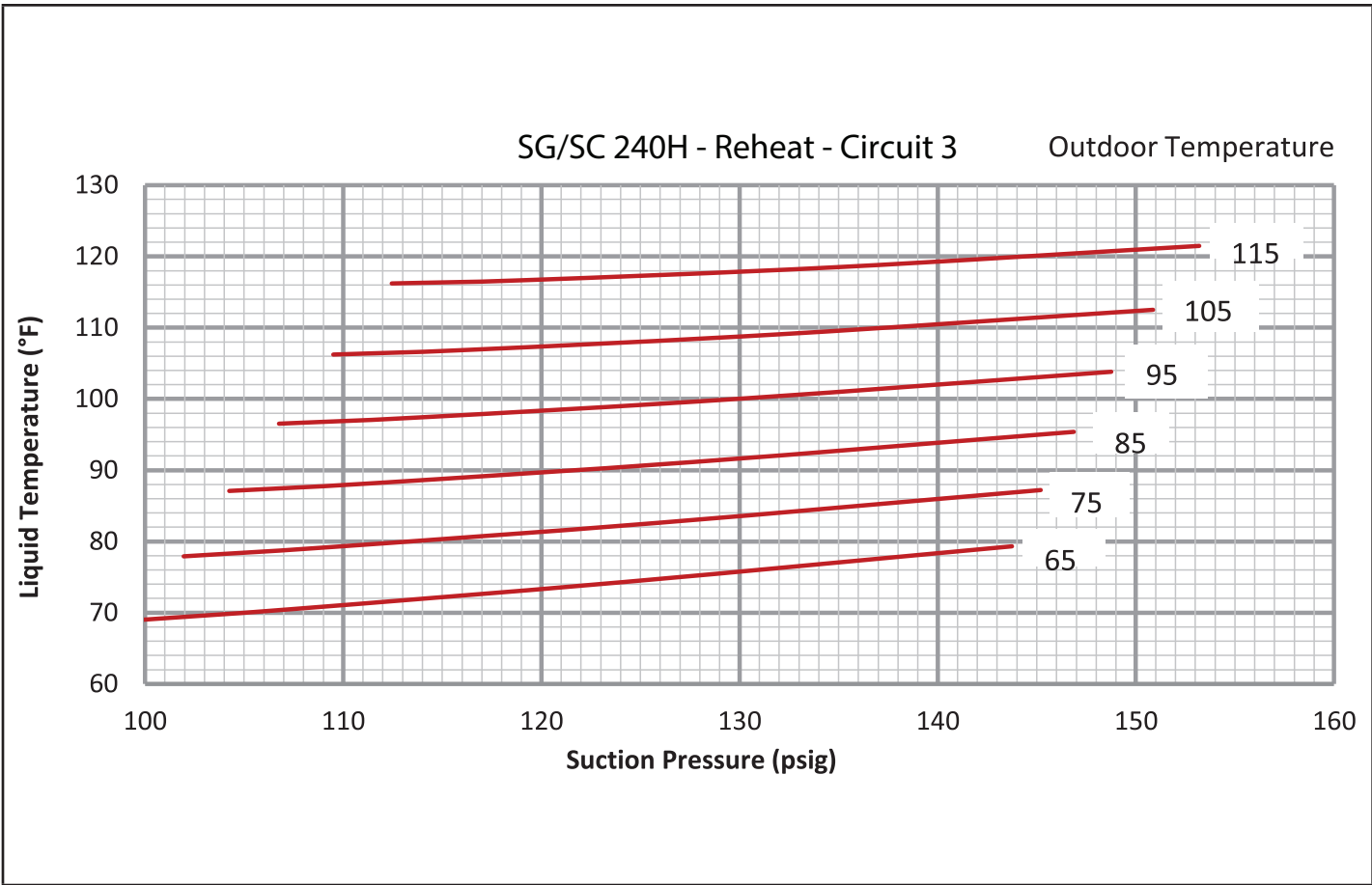

III- START-UP OPERATION

A-Cooling Start-up

NOTE-Crankcase heaters must be energized 24 hours before attempting to start compressor. Set thermostat so that there is no demand to prevent compressor from cycling. Apply power to unit.

MSAV™ Units and Units Equipped With Voltage or Phase Detection - The Unit Controller checks the incoming power during start-up. If the voltage or phase is incorrect, the Unit Controller will display an alarm and the unit will not start.

- 1 - Initiate first and second stage cooling demands according to instructions provided with thermostat. Refer to the Optional Supply Air VFD section on MSAV™ units
- 2 - *SG/SC 120 Units* - First-stage thermostat demand will energize compressor 1. Second-stage thermostat demand will energize compressor 2. On units with an economizer, when outdoor air is acceptable, a first-stage demand will energize the economizer; a second-stage demand will energize compressor 1.
SG/SC 240 Units - First-stage thermostat demand will energize compressors 1 and 2. Second-stage thermostat demand will energize compressors 3 and 4. On units with an economizer, when outdoor air is acceptable, a first-stage demand will energize the economizer; a second-stage demand will energize compressors 1 and 2.
- 3 - SG/SC 120 units contain two refrigerant circuits and two stages of cooling. See FIGURE 8.
- 4 - SG/SC 240 units contain four refrigerant circuits or systems. Evaporator and condenser coil refrigerant circuits 1 and 2 make up stage 1 cooling in thermostat mode. Evaporator and condenser refrigerant circuits 3 and 4 make up stage 2 cooling in thermostat mode. See FIGURE 9.

IMPORTANT

Three Phase Scroll Compressor Voltage Phasing

Three phase scroll compressors must be phased sequentially to ensure correct compressor and blower* rotation and operation. Compressor and blower are wired in phase at the factory. Power wires are color-coded as follows: line 1-red, line 2-yellow, line 3-blue.

1- Observe suction and discharge pressures and blower* rotation on unit start-up.

2- Suction pressure must drop, discharge pressure must rise and blower* rotation must match rotation marking.

If pressure differential is not observed or blower* rotation is not correct:

3- Disconnect all remote electrical power supplies.

4- Reverse any two field-installed wires connected to the line side of S48 disconnect or TB13 terminal strip. Do not reverse wires at blower contactor.

5- Make sure the connections are tight.

Discharge and suction pressures should operate at their normal start-up ranges.

*Supply air VFD motors should rotate in the correct direction; verify scroll compressor rotation separately. Contact technical support if the VFD blower is rotating incorrectly. The blower rotation will always be correct on MSAV™ units (120/240 units will always have VFD motors). Checking blower rotation is not a valid method of determining voltage phasing for incoming power.

B-Electric Heat Start-up

Electric heat will stage on and cycle with thermostat demand. Number of stages of electric heat will vary depending on electric heat assembly. See electric heat wiring diagram on unit for sequence of operation

IV- SYSTEMS SERVICE CHECKS

A-Preliminary and Seasonal Checks

- 1 - Make sure the unit is installed in accordance with the installation instructions and applicable codes.
- 2 - Inspect all electrical wiring, both field and factory installed for loose connections. Tighten as required. Refer to unit diagram located on inside of unit control box cover.
- 3 - Check to ensure that refrigerant lines are in good condition and do not rub against the cabinet or other refrigerant lines.
- 4 - Check voltage. Voltage must be within the range listed on the nameplate. If not, consult power company and have the voltage corrected before starting the unit.
- 5 - Recheck voltage and amp draw with unit running. If voltage is not within range listed on unit nameplate, stop unit and consult power company. Refer to unit nameplate for maximum rated load amps.

Inspect and adjust blower belt (see section on Blower Compartment - Blower Belt Adjustment) SCH units are factory charged and require no further adjustment; however, charge should be checked periodically. See section II- CHARGING

V-MAINTENANCE

⚠ WARNING	
	Electric shock hazard. Can cause injury or death. Before attempting to perform any service or maintenance, turn the electrical power to unit OFF at disconnect switch(es). Unit may have multiple power supplies.

⚠ WARNING	
Any service personnel installing, decommissioning, or performing maintenance on the unit must be properly trained with A2L refrigerants	

Prior to beginning work on systems containing refrigerant to ensure the risk of ignition is minimized:

- All work shall be undertaken under a controlled procedure so as to minimize the risk of a flammable gas or vapor being present while the work is being performed.
- The area shall be checked with an appropriate refrigerant detector prior to and during work, to ensure the technician is aware of potentially toxic or flammable atmospheres. Ensure that the leak detection equipment being used is suitable for use with all applicable refrigerants, i. e. non-sparking, adequately sealed or intrinsically safe.
- If any hot work is to be conducted on the refrigerating equipment or any associated parts, the appropriate fire extinguishing equipment shall be

available to hand. Have a dry powder or CO2 fire extinguisher adjacent to the charging area.

- No person carrying out work in relation to a refrigerating system which involves exposing any pipe work shall use any sources of ignition in such a manner that it may lead to the risk of fire or explosion. All possible ignition sources, including cigarette smoking, should be kept sufficiently far away from the site of installation, repairing, removing and disposal, during which refrigerant can possibly be released to the surrounding space. Prior to work taking place, the area around the equipment is to be surveyed to make sure that there are no flammable hazards or ignition risks. "No Smoking" signs shall be displayed.
- Ensure that the area is in the open or that it is adequately ventilated before breaking into the system or conducting any hot work.

A degree of ventilation shall continue during the period that the work is carried out. The ventilation should safely disperse any released refrigerant and preferably expel it externally into the atmosphere.

- Where electrical components are being changed, service technicians shall be fit for the purpose and to the correct specification. At all times the manufacturer's maintenance and service guidelines shall be followed. If in doubt, consult the manufacturer's technical department for assistance. The following checks shall be applied to installations using flammable refrigerants as applicable:
 - 1 - The actual refrigerant charge is in accordance with the room size within which the refrigerant containing parts are installed.
 - 2 - The ventilation machinery and outlets are operating adequately and are not obstructed.
 - 3 - If an indirect refrigerating circuit is being used, the secondary circuit shall be checked for the presence of refrigerant.
 - 4 - Markings on the equipment should be visible and legible. Markings and signs that are illegible shall be corrected.
 - 5 - Refrigerating pipes or components are installed in a position where they are unlikely to be exposed to any substance which may corrode refrigerant containing components, unless the components are constructed of materials which are inherently resistant to being corroded or are suitably protected against being so corroded.

- For systems containing refrigerant all repair and maintenance to electrical components shall include initial safety checks and component inspection procedures such as that capacitors are discharged in a safe manner to avoid possibility of sparking, that no live electrical components and wiring are exposed while charging, recovering, or purging the system, and that there is continuity of earth bonding. If a fault exists that could compromise safety, then no electrical supply shall be connected to the circuit until it is satisfactorily dealt with. If the fault cannot be corrected immediately but it is necessary to continue operation, an adequate temporary solution shall be used that is reported to the owner of the equipment, so all parties are advised.

NOTE - Sealed electrical components shall be replaced, not repaired.

NOTE - Intrinsically safe components must be replaced, not repaired.
- Under no circumstances shall potential sources of ignition be used in the searching for or detection of refrigerant leaks. A halide torch (or any other detector using a naked flame) shall not be used. Electronic leak detectors may be used to detect refrigerant leaks but, in the case of flammable refrigerants, the sensitivity may not be adequate, or may need re-calibration. (Detection equipment shall be calibrated in a refrigerant-free area.) Ensure that the detector is not a potential source of ignition and is suitable for the refrigerant used. Leak detection equipment shall be set at a percentage of the LFL of the refrigerant and shall be calibrated to the refrigerant employed, and the appropriate percentage of gas (25 % maximum) is confirmed. Leak detection fluids are also suitable for use with most refrigerants but the use of detergents containing chlorine shall be avoided as the chlorine may react with the refrigerant and corrode the copper pipe-work. If a leak is suspected, all naked flames shall be removed/extinguished. If a leakage of refrigerant is found which requires brazing, all of the refrigerant shall be recovered from the system, or isolated (by means of shut off valves) in a part of the system remote from the leak.
- When breaking into the refrigerant circuit to make repairs – or for any other purpose – conventional procedures shall be used. However, for flammable refrigerants it is important that best practice be followed, since flammability is a consideration. The following procedure shall be adhered to:
 - a. Safely remove refrigerant following local and national regulations,
 - b. Evacuate the circuit,
 - c. Purge the circuit with inert gas,
 - d. Evacuate,
 - e. Purge with inert gas,
 - f. Open the circuit.
- The refrigerant charge shall be recovered into the correct recovery cylinders if venting is not allowed by local and national codes. For appliances containing flammable refrigerants, the system shall be purged with oxygen-free nitrogen to render the appliance safe for flammable refrigerants. This process might need to be repeated several times. Compressed air or oxygen shall not be used for purging refrigerant systems. Refrigerant purging shall be achieved by breaking the vacuum in the system with oxygen-free nitrogen and continuing to fill until the working pressure is achieved, then venting to atmosphere, and finally pulling down to a vacuum. This process shall be repeated until no refrigerant is within the system. When the final oxygen-free nitrogen charge is used, the system shall be vented down to atmospheric pressure to enable work to take place. Ensure that the outlet for the vacuum pump is not close to any potential ignition sources and that ventilation is available.

A-Filters

Units are equipped with filters as shown in TABLE 9. Units will accept 4" filters. Filters should be checked monthly and replaced when necessary with filters of like kind and size. Take note of air flow direction marking on filter frame when reinstalling filters.

NOTE - Filters must be U.L.C. certified or equivalent for use in Canada.

TABLE 9

SG/SC Unit	Qty	Filter Size - inches (mm)
120	4	20 X 25 X 2 (508 X 635 X 51)
240	12	20 X 20 X 2 (508 X 508 X 51)

B-Lubrication

All motors and blower wheels used in SCH units are lubricated; no further lubrication is required.

C-Supply Air Blower Wheel

Annually inspect supply air blower wheel for accumulated dirt or dust. Turn off power before attempting to remove access panel or to clean blower wheel.

D-Evaporator Coil

Inspect and clean coil at beginning of each season. Clean using mild detergent or commercial coil cleanser. Check condensate drain pan and line, if necessary. Flush coil and condensate drain with water taking care not to get insulation, filters and return air ducts wet. Check connecting lines and coil for evidence of oil and refrigerant leaks.

E-Condenser Coil

Clean condenser coil annually with detergent or commercial coil cleaner and inspect monthly during the cooling season. Check connecting lines and coil for evidence of oil and refrigerant leaks.

Clean the all-aluminum coil by spraying the coil steadily and uniformly from top to bottom. Do not exceed 900 psi or a 45 angle; nozzle must be at least 12 inches from the coil face. Take care not to fracture the braze between the fins and refrigerant tubes. Reduce pressure and work cautiously to prevent damage.

NOTE-If owner complains of insufficient cooling, the unit should be gauged and refrigerant charge checked. Refer Charging section in this manual

F-Electrical

- 1 - Check all wiring for loose connections.
- 2 - Check for correct voltage at unit (unit operating).
- 3 - Check amp-draw on both condenser fan motor and blower motor.

Fan Motor Rating Plate ____ Actual _____

Indoor Blower Motor Rating Plate ____ Actual ____

- 4 - Check crankcase heater temperatures to ensure they are operating.

VI-ACCESSORIES

The accessories section describes the application of most of the optional accessories which can be factory or field installed to the SGH units.

A-Roof Curbs

When installing the SGH units on a combustible surface for downflow discharge applications, the hybrid S1CURB71 (11F70, 11F72, or 11F74) 14-in height and S1CURB73 (11F71, 11F73, or 11F75) 24-in roof mounting frame is used. The assembled hybrid mounting frame is shown in FIGURE 28, FIGURE 29, and FIGURE 30. Refer to the roof mounting frame installation instructions for details of proper assembly and mounting. The roof mounting frame **MUST** be squared to the roof and level before mounting. Plenum system **MUST** be installed before the unit is set on the mounting frame. Typical roof curbing and flashing is shown in FIGURE 31. Refer to the roof mounting frame installation instructions for proper plenum construction and attachment.

NOTE - When installing a D-Box unit on an existing C-box curb, a Factory installed curb alignment kit is required. Refer to the unit installation instructions for more details.

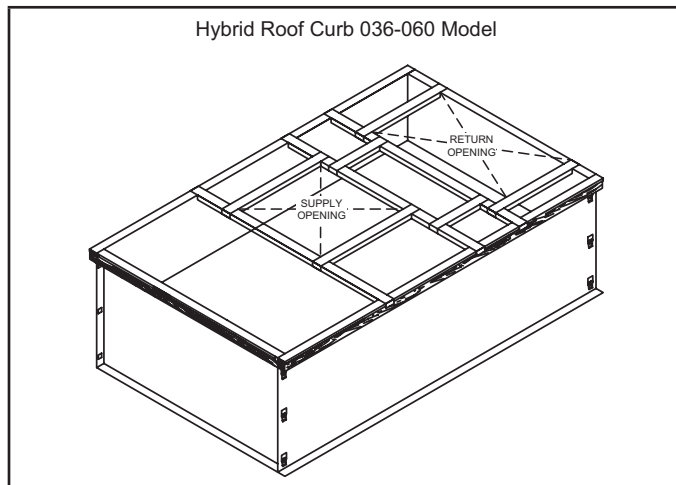

FIGURE 28

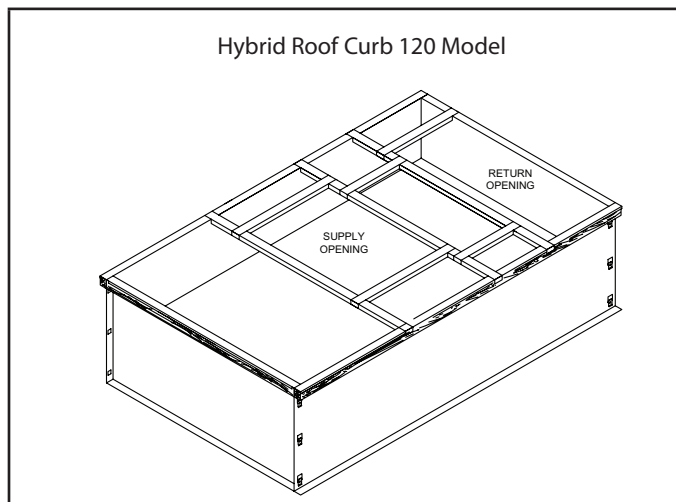

FIGURE 29

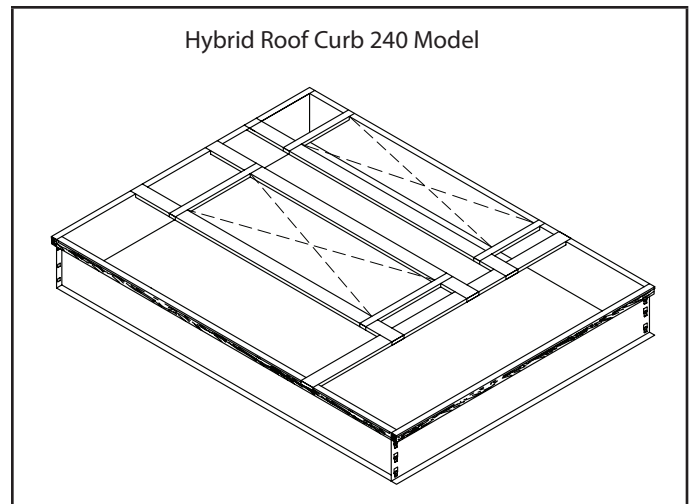

FIGURE 30

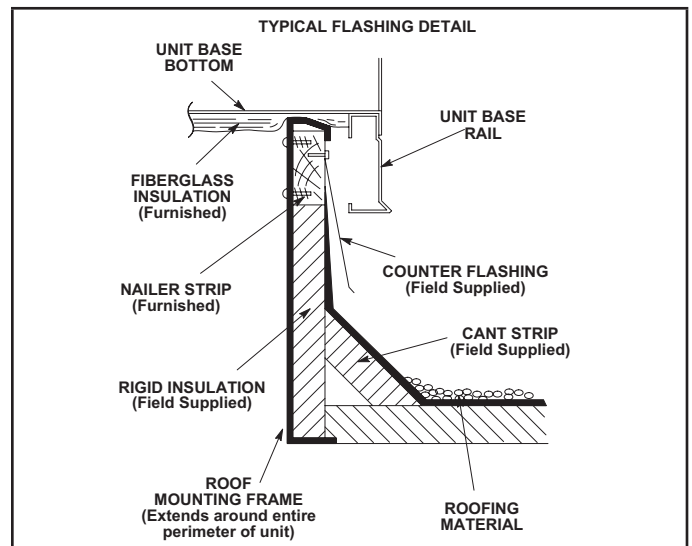

FIGURE 31

B-Outdoor Air Dampers (FIGURE 32)

Dampers are manually or motor operated to allow up to 25 percent outside air into the system at all times. Either air damper can be installed in 240 units. Washable filter supplied with the outdoor air dampers can be cleaned with water and a mild detergent. It should be sprayed with Filter Handicoater when dry prior to reinstallation. Filter Handicoater is R.P. Products coating no. 418 and is available as Part No. P-8-5069.

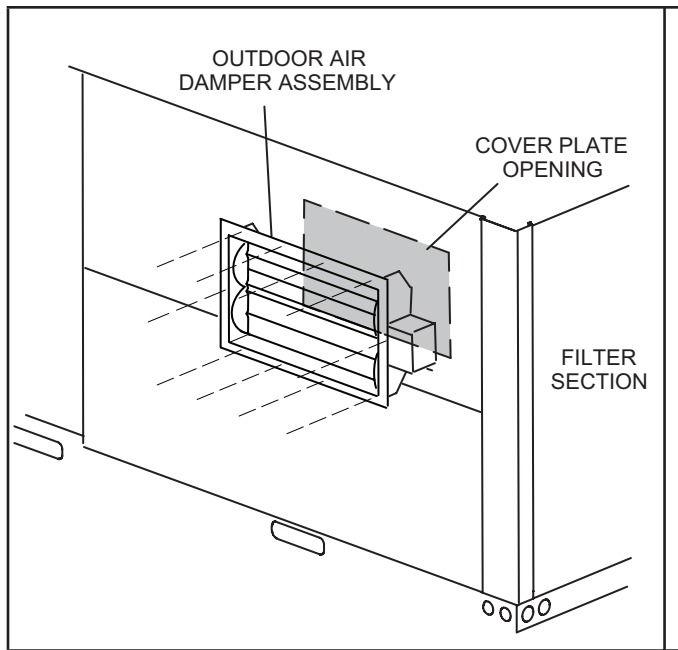

FIGURE 32

C-Economizer (Field or Factory Installed)

General

The economizer allows outdoor air to be used for free cooling or ventilation requirements.

Configure Economizer

Use the following menu and go through the installation wizard.

SETUP > INSTALL

When prompted, set Configuration ID 1, position 2 to the applicable economizer option. Economizer options are shown in TABLE 10. Once the option is set, the installation wizard prompts will vary depending on the option selected

NOTE - Some setup information is factory-set, such as the unit model number. Verify that each setting is correct before advancing to the next prompt.

Sensors are used to determine outdoor air suitability for free cooling. Some economizer options require field-installed sensors. See TABLE 10. See FIGURE 33 for sensor locations.

Use the following menu to make adjustments to the economizer option once configured. Refer to the Menu Interface tables in the Unit Controller Setup Guide provided with this unit.

TEST & BALANCE > DAMPER CONFIGURATION.

Economizer Operation

NOTE- Use indicating lights on Unit Controller to determine thermostat demand.

See TABLE 11 for economizer operation with a standard two-stage thermostat

Damper Minimum Position Setting

Use the following menu path to modify the minimum damper positions for both high and low operations.

TEST&BALANCE>DAMPER CALIBRATION>BLOWER SPEED HIGH>MINIMUM DAMPER POSITION X.X%

TEST&BALANCE>DAMPER CALIBRATION>BLOWER SPEED LOW>MINIMUM DAMPER POSITION X.X%

TABLE 12 shows economizer operation with an energy management system which uses a global sensor.

Both tables show the occupied and unoccupied time period. The occupied time period is determined by the thermostat or energy management system.

TABLE 12 shows economizer operation in zone sensor mode.

IAQ Damper Operation

The Unit Controller has a 0-10VDC IAQ input for a standard 0-2000ppm CO2 sensor. The economizer starts opening at a CO2 level of 700 ppm (default) and reaches full open at a CO2 level of 1200ppm. Adjustments may be made to the indoor air quality parameters to alter operation or meet required specifications (parameters 117 through 119). Go to:

TEST & BALANCE > DAMPER CONFIGURATION

If the economizer is operating in the free cooling mode and the IAQ sensor demands more fresh air, the IAQ demand will override the free cooling demand to open the dampers further or to keep them open.

The IAQ function is not energized during the unoccupied or night time period.

**TABLE 10
ECONOMIZER CONFIGURATION OPTIONS**

Option	Description	Required Sensors	Dampers will modulate to 55°F* (default) discharge air when outdoor air is suitable:	Parameter**
M	MOTORIZED OUTDOOR AIR DAMPERS	None	Dampers do not modulate; dampers will open to minimum position during the occupied time period and close during the unoccupied time period.	NA
T	ECONOMIZER FREE COOLING TEMPERATURE OFFSET	Factory-installed	Outdoor air temperature (RT17) is less than return air temperature (RT16) by at least the OFFSET value (10°F default).	161
	ECONOMIZER FREE COOLING TEMPERATURE SETPOINT	Factory-installed	Outdoor air temperature (RT17) is less than the free cooling setpoint (60°F default).	160
G	GLOBAL	NA	Dampers will modulate to maintain 55°F* (default) discharge air when a 24VAC signal is provided to the GLO input (P297-9). Global input also brings on the blower. Refer to Energy Management System manufacturer's instructions for required sensors.	NA
S	ECONOMIZER FREE COOLING ENTHALPY SETPOINT	C7400	Outdoor air enthalpy (A7) is less than free cooling setpoint (73°F default).	162
D	ECONOMIZER FREE COOLING ENTHALPY OFFSET	(Two) C7400	Outdoor air enthalpy (A7) is less than return air enthalpy (A62) by at least the OFFSET value.	163

*RT6 discharge air sensor is factory-installed. See parameter 159 in the Unit Controller Setup Guide.

**Refer to the Menu Interface tables in the Unit Controller Setup Guide provided with this unit.

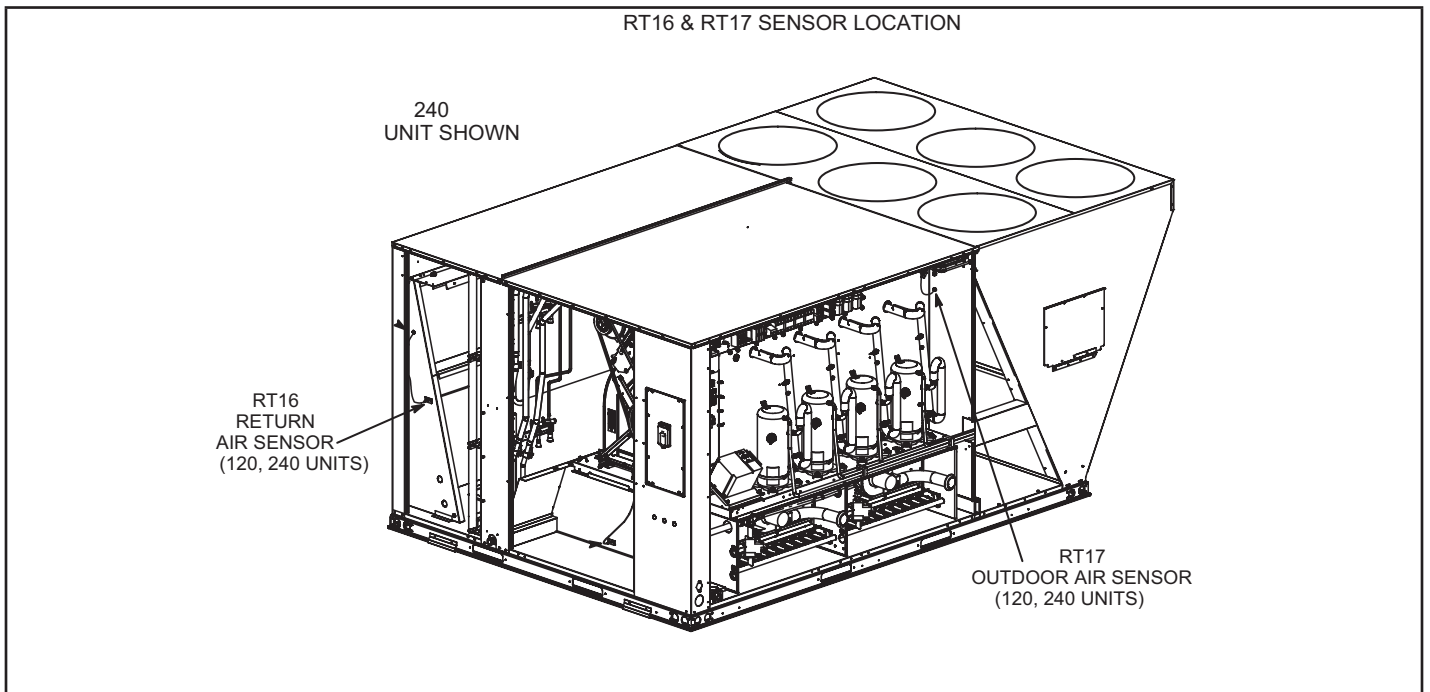

FIGURE 33

TABLE 11
ECONOMIZER OPERATION - Standard Two-Stage Thermostat (Default Option)

THERMOSTAT DEMAND	DAMPER POSITION UNOCC.	DAMPER POSITION OCCUPIED	MECHANICAL COOLING
OUTDOOR AIR IS NOT SUITABLE FOR FREE COOLING			
OFF	CLOSED	CLOSED	NO
G	CLOSED	MINIMUM	NO
Y1	CLOSED	MINIMUM	STAGE 1
Y2	CLOSED	MINIMUM	STAGES 1 AND 2
OUTDOOR AIR IS SUITABLE FOR FREE COOLING			
OFF	CLOSED	CLOSED	NO
G	CLOSED	MINIMUM	NO
Y1	MODULATING	MODULATING	NO
Y2	MODULATING	MODULATING (1)	STAGE 1

NOTE - Modulating dampers adjust to control supply air (RT6) to 55°F (13°C). (1) The Unit Controller goes into a "cool down" or "warm-up" mode when the occupied time period starts. (2) Units with two-stage compressor operation will operate only stage 1 with a Y2 demand.

TABLE 12
ECONOMIZER OPERATION WITH GLOBAL SENSING - Energy Management System (Default Option)

THERMOSTAT DEMAND	DAMPER POSITION UNOCC.	DAMPER POSITION OCCUPIED	MECHANICAL COOLING
GLOBAL INPUT OFF			
OFF	CLOSED	CLOSED	NO
G	CLOSED	MINIMUM	NO
Y1	CLOSED	MINIMUM	STAGE 1
Y2	CLOSED	MINIMUM	STAGES 1 AND 2
GLOBAL INPUT ON			
OFF	MODULATING	MODULATING	NO
G	MODULATING	MODULATING	NO
Y1	MODULATING	MODULATING	STAGE 1
Y2	MODULATING	MODULATING (1)	STAGES 1 AND 2 (2)

NOTE - Modulating dampers adjust to control supply air (RT6) to 55°F (13°C). (1) The Unit Controller goes into a "cool down" or "warm-up" mode when the occupied time period starts. (2) Units with two-stage compressor operation will operate only stage 1 with a Y2 demand (default).

TABLE 13
ECONOMIZER OPERATION - Zone Sensor Mode

DEMAND	DAMPER POSITION UNOCC.	DAMPER POSITION OCCUPIED	MECHANICAL COOLING
OUTDOOR AIR IS NOT SUITABLE FOR FREE COOLING			
OFF	CLOSED	CLOSED	NO
G	CLOSED	MINIMUM	NO
Cooling Stage 1	CLOSED	MINIMUM	COMPRESSOR 1
Cooling Stage 2	CLOSED	MINIMUM	COMPRESSOR 1 & 2
Cooling Stage 3	CLOSED	MINIMUM	COMPRESSOR 1, 2, & 3
Cooling Stage 4	CLOSED	MINIMUM	COMPRESSOR 1, 2, 3, & 4
OUTDOOR AIR IS SUITABLE FOR FREE COOLING			
OFF	CLOSED	CLOSED	NO
G	CLOSED	MINIMUM	NO
Cooling Stage 1	MODULATING	MODULATING	NO
Cooling Stage 2	FULL OPEN*	FULL OPEN*	COMPRESSOR 1
Cooling Stage 3	FULL OPEN*	FULL OPEN*	COMPRESSORS 1 & 2
Cooling Stage 4	FULL OPEN*	FULL OPEN*	COMPRESSORS 1, 2, 3, & 4

Damper will modulate to maintain 55°F supply air when parameter 164 is changed to setting "0". Note - Modulating dampers adjust to control supply air (RT6) to 55°F (13°C).

D-Gravity Exhaust Dampers

Dampers (FIGURE 34 and FIGURE 35) are used in downflow applications. Gravity exhaust dampers are installed in the return air plenum. The dampers must be used any time an economizer or power exhaust fans are applied to SGH series units. An exhaust hood is furnished with the gravity exhaust damper.

Gravity exhaust dampers allow exhaust air to be discharged from the system when an economizer and/or power exhaust is operating. Gravity exhaust dampers also prevent outdoor air infiltration during unit off cycle. See installation instructions for more detail.

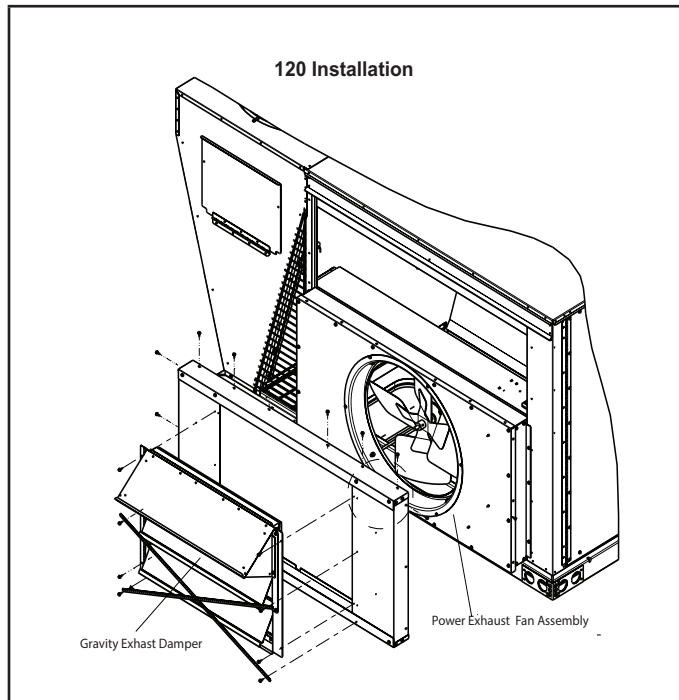

FIGURE 34

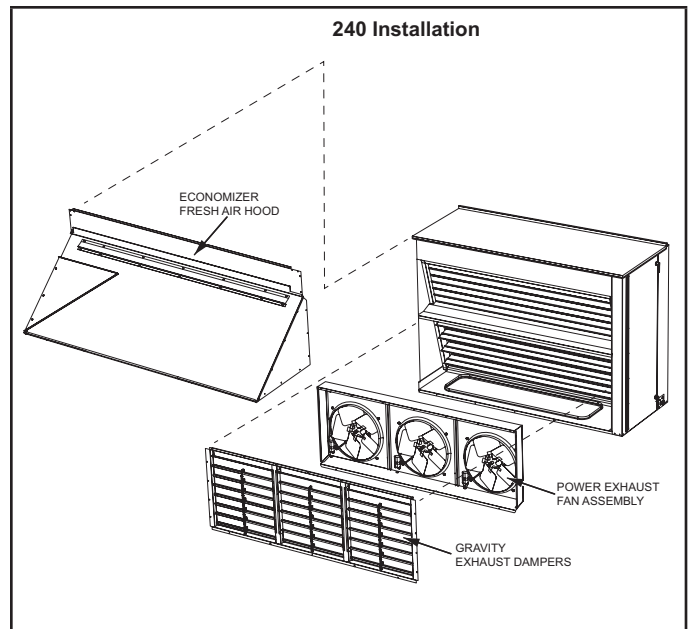

FIGURE 35

E-Power Exhaust Fans

Power exhaust fans (FIGURE 34 and FIGURE 35) are used in downflow applications only. Fans require optional downflow gravity exhaust dampers and economizers. Power exhaust fans provide exhaust air pressure relief and also run when return air dampers are closed and supply air blowers are operating. See installation instructions for more detail.

F-Control Systems

The A55 Unit Controller provides all control function for the rooftop unit. Default operation requires a standard room thermostat or direct digital controller (DDC). The A55 can also control the unit from a zone temperature sensor. The A55 Unit Controller is a network controller when daisy-chained to the L Connection® Network Control System. For ease of configuration, the A55 can be connected to a PC with Unit Controller PC software installed.

G-Smoke Detectors A171, A172, A173

Photoelectric smoke detectors are a factory- and field-installed option. The smoke detectors can be installed in the supply air section (A172), return air section (A171), or in both the supply and return air section. Smoke detection control module (A173) is located below the control panel.

H-Blower Proving Switch S52

The blower proving switch monitors blower operation and locks out the unit in case of blower failure. The switch is N.O. and closes at .15" W.C. The switch is mounted on the middle left corner of the blower support panel.

I-Dirty Filter Switch S27

The dirty filter switch senses static pressure increase indicating a dirty filter condition. The switch is N.O. and closes at 1" W.C. The switch is mounted on the top corner of the economizer.

J-Indoor Air Quality (CO2) Sensor A63

The indoor air quality sensor monitors CO2 levels and reports the levels to the A55 Unit Controller. The board adjusts the economizer dampers according to the CO2 levels. The sensor is mounted next to the indoor thermostat or in the return air duct. Refer to the indoor air quality sensor installation instructions for proper adjustment. .

K-Drain Pan Overflow Switch S149 (optional)

The overflow switch is used to interrupt cooling operation when excessive condensate collects in the drain pan. The N.C. overflow switch is connected to the M2 Unit Controller (A55) through DI-3. When the switch opens, the Unit Controller will shut off the unit. After a five-minute time out, the Unit Controller will verify the overflow switch position and restart the unit (if the switch has closed). The Unit Controller has a three-strike counter before the unit locks out. This means the Unit Controller will allow the overflow switch to open three times per thermostat demand. If the unit locks out, a reset of the Unit Controller is required after the switch has closed to restore unit operation.

L- Hot Gas ReHeat

Hot gas reheat units provide a dehumidifying mode of operation. These units contain a reheat coil adjacent to and downstream of the evaporator coil. Reheat coil solenoid valve, L14 (and L30 on 240 units), routes hot discharge gas from the compressor to the reheat coil. Return air pulled across the evaporator coil is cooled and dehumidified; the reheat coil adds heat to supply air.

See FIGURE 36 and FIGURE 37 for reheat refrigerant routing.

L14/L30 Reheat Coil Solenoid Valve

When Unit Controller input (Unit Controller J298-5 or J299-8) indicates room conditions require dehumidification, L14/L30 reheat valve is energized (Unit Controller P269-3 or P269-4) and refrigerant is routed to the reheat coil.

Reheat Setpoint

Reheat is factory-set to energize when indoor relative humidity rises above 60% (default). The reheat setpoint can be adjusted by changing Unit Controller Settings - Control menu. A setting of 100% will operate reheat from an energy management system digital output

Reheat will terminate when the indoor relative humidity falls 3% (57% default) or the digital output de-energizes. The reheat deadband can be adjusted at Settings - Control menu.

A91 Humidity Sensor (120 & 240 Units)

Relative humidity should correspond to the sensor (A91) output voltage listed in TABLE 14. For example: if indoor air relative humidity is 80% \pm 3%, the humidity sensor output should read 8.00VDC.

Check the sensor output annually for accuracy. Keep the air intake openings on the sensor clean and free of obstructions and debris.

TABLE 14

Relative Humidity (%RH \pm 3%)	Sensor Output (VDC)
20	2.00
30	3.00
40	4.00
50	5.00
60	6.00
70	7.00
80	8.00
90	9.00

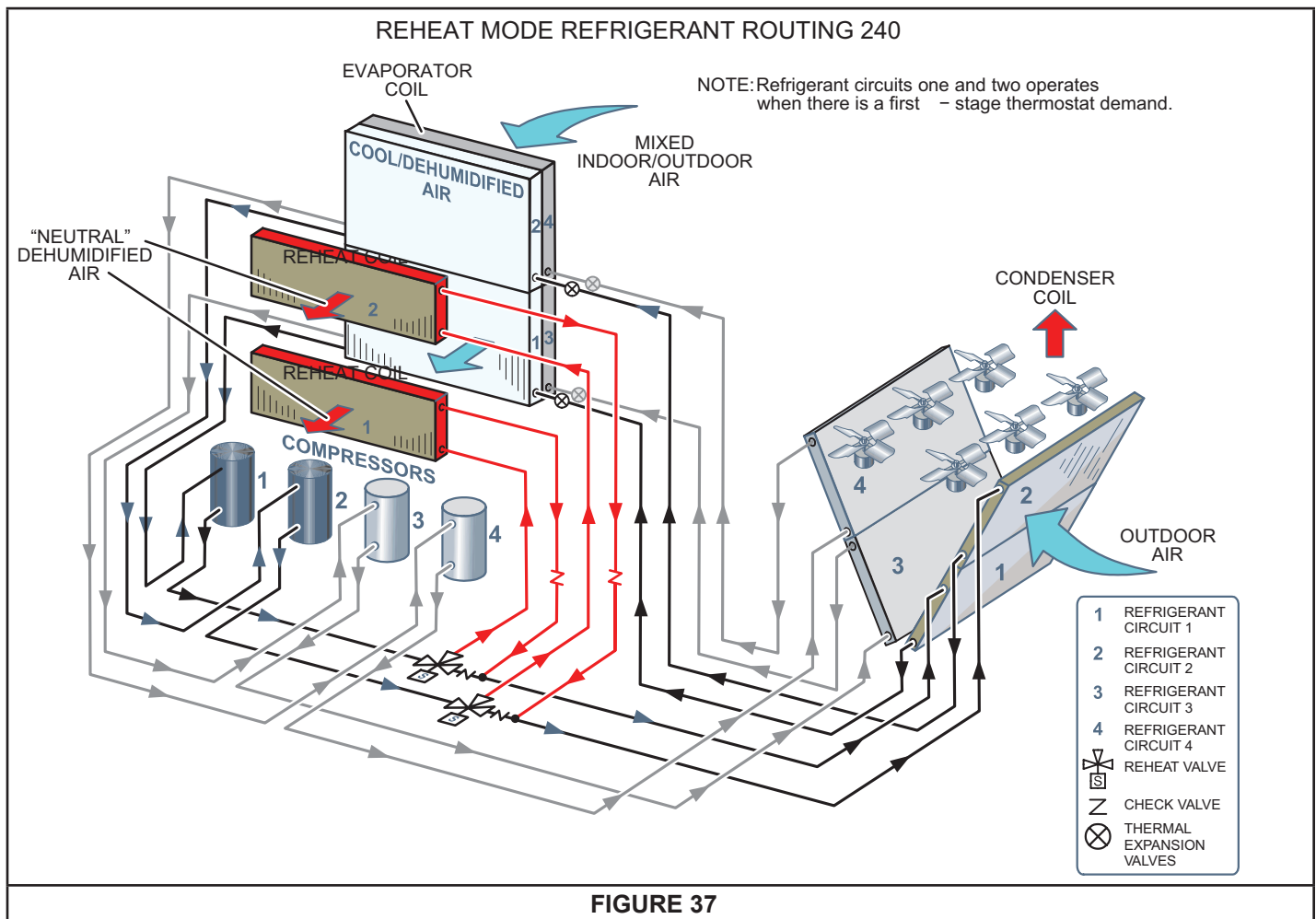
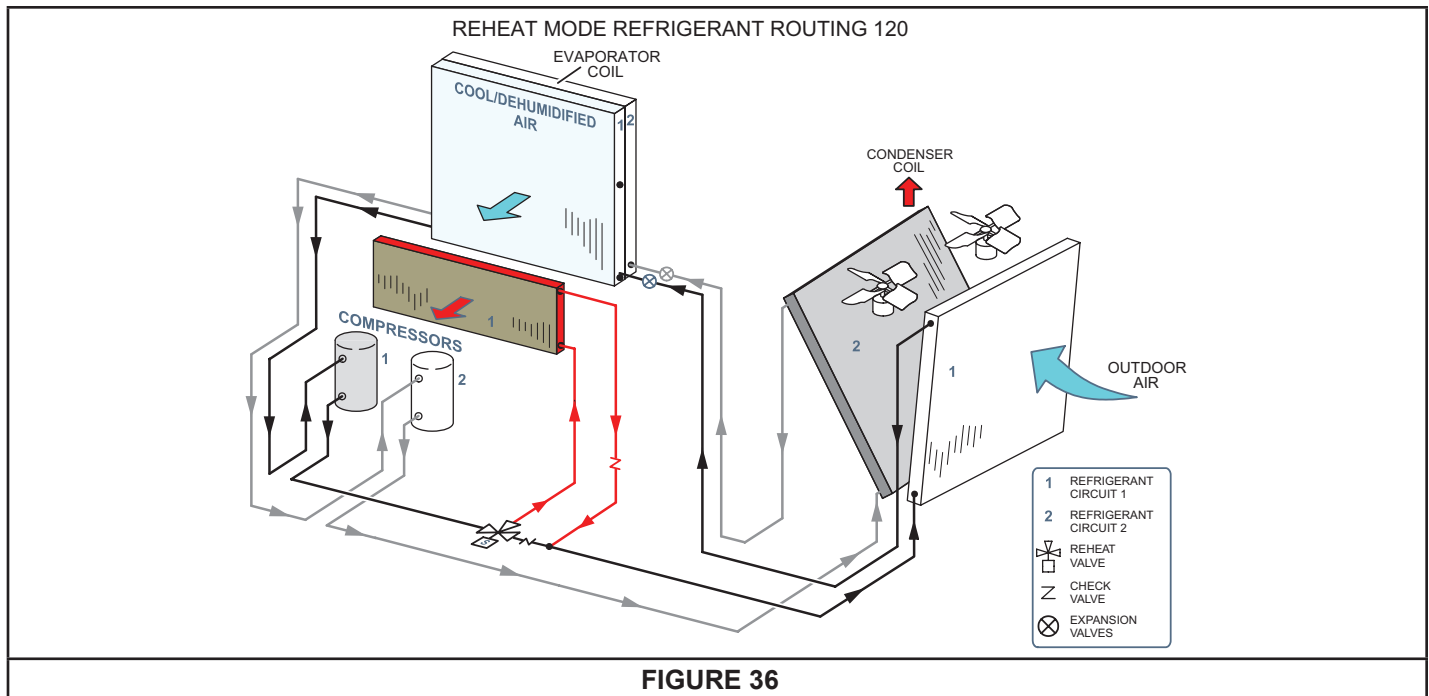

Check-Out

Test reheat operation using the following procedure.

- 1 - Make sure reheat is wired as shown in wiring section.
- 2 - Make sure unit is in local thermostat mode.
- 3 - Use Unit Controller application to elect :

SERVICE > TEST > DEHUMIDIFIER

120 -

The blower and compressor (reheat) should be operating. **DEHUMIDIFIER 1 ON** will be appear on the Unit Controller display.

240 -

The blower, compressor 1, and compressor 2 (reheat) should be operating. L14 and L30 LEDs on the Unit Controller should also be **ON**, indicating the reheat valves are energized. **REHEAT MODE** will be appear on the Unit Controller display.

- 4 - Press **BACK** on the Unit Controller display to stop the testing mode.

Default Reheat Operation - 120

TABLE 15

Reheat Operation - Two Cooling Stages - Default

T'stat and Humidity Demands	Operation
Reheat Only	Compressor 1 Reheat & Blower Low Speed
Reheat & Y1	Compressor 1 Reheat & Compressor 2 Cooling* & Blower High Speed
Reheat & Y1 & Y2	Compressor 1 Cooling & Compressor 2 Cooling** & Blower High Speed

*If there is no reheat demand and outdoor air is suitable, free cooling will operate.

**If there is no reheat demand and outdoor air is suitable free cooling and compressor 1 will operate.

Default Reheat Operation - 240

Reheat will operate as shown in TABLE 16 once three conditions are met:

- 1 - Blower must be operating.
- 2 - System must be in occupied mode.
- 3 - System must NOT be operating in heating mode.

IMPORTANT - Free cooling does not operate during reheat.

For other reheat control options, refer to the Unit Controller manual.

Additional Cooling Stages

Units are shipped from the factory to provide two stages of cooling.

Three stages of cooling is available in zone sensor mode. Three stages of cooling is also available by installing a transfer relay and a three-stage thermostat. Refer to the Main Control Operation section in the Unit Controller manual when using the transfer relay.

Additional Cooling Stages - 240

Four stages of cooling is available in zone sensor mode on units with four compressors.

Compressors are not de-energized when unit operation changes from cooling to reheat or from reheat to cooling. Instead, L14 and L30 reheat valves are energized (reheat) or de-energized (cooling).

NOTE - Another thermostat staging option is available which allows both compressors to be energized during free cooling. See Unit Controller manual for details.

**TABLE 16
REHEAT OPERATION**

Two-Stage Thermostat - Default	
T'stat and Humidity Demands	Operation
	240 (4-Compressors)
Reheat Only	Compressor 1 & 2 Reheat
Reheat & Y1	Compressor 1 & 2 Reheat Compressor 3 & 4 Cooling ¹
Reheat & Y1 & Y2	Compressor 1, 2, 3, & 4 Cooling ³
Three-Stage Thermostat (Transfer relay required)	
T'stat and Humidity Demands	Operation
	240 (4-Compressors)
Reheat Only	Compressor 1 & 2 Reheat
Reheat & Y1	Compressor 1 & 2 Reheat Compressor 3 & 4 Cooling ²
Reheat & Y1 & Y2	Compressor 1 & 2 Reheat Compressor 3 & 4 Cooling ³
Reheat Y1 & Y2 & Y3	Compressor 1, 2, 3, & 4 Cooling ⁴
Four-Stage Zone Sensor Mode	
Cooling* and Humidity** Demands	Operation
	240 (4-Compressors)
Reheat Only	Compressor 1 & 2 Reheat
Reheat & Y1	Compressor 1 & 2 Reheat Compressor 3 Cooling ¹
Reheat & Y1 & Y2	Compressor 1 & 2 Reheat Compressor 3 & 4 Cooling ²
Reheat Y1 & Y2 & Y3	Compressor 1 Reheat, Compressor 2, 3, & 4 Cooling ³
Reheat Y1 & Y2 & Y3 & Y4	Compressor 1, 2, 3, & 4 Cooling ⁵

*Cooling stage is initiated when zone temperature is higher than the cooling setpoint plus the appropriate stage differential.

**Reheat demand is initiated when relative humidity is higher than relative humidity setpoint.

¹If there is no reheat demand and outdoor air is suitable, free cooling will operate.

²If there is no reheat demand and outdoor air is suitable, free cooling and compressor 1 will operate.

³If there is no reheat demand and outdoor air is suitable, free cooling and compressor 1 and 2 will operate.

⁴If there is no reheat demand and outdoor air is suitable, free cooling, compressor 1, 2 and 3 will operate.

⁵If there is no reheat demand and outdoor air is suitable, free cooling, compressor 1, 2, 3 and 4 will operate.

**The following conditions must be met before reheat will be energized:
(factory-default; see Unit Controller manual for other options)**

- 1 - Blower must be operating.
- 2 - System must be in occupied mode.
- 3 - System must NOT be operating in heating mode.

VII - MSAV™ Unit Start-Up & Operation

Units may contain a supply air blower equipped with a variable frequency drive A96 (VFD) which stages supply air CFM.

The supply air VFD (A96) is located near the compressors. See FIGURE 38.

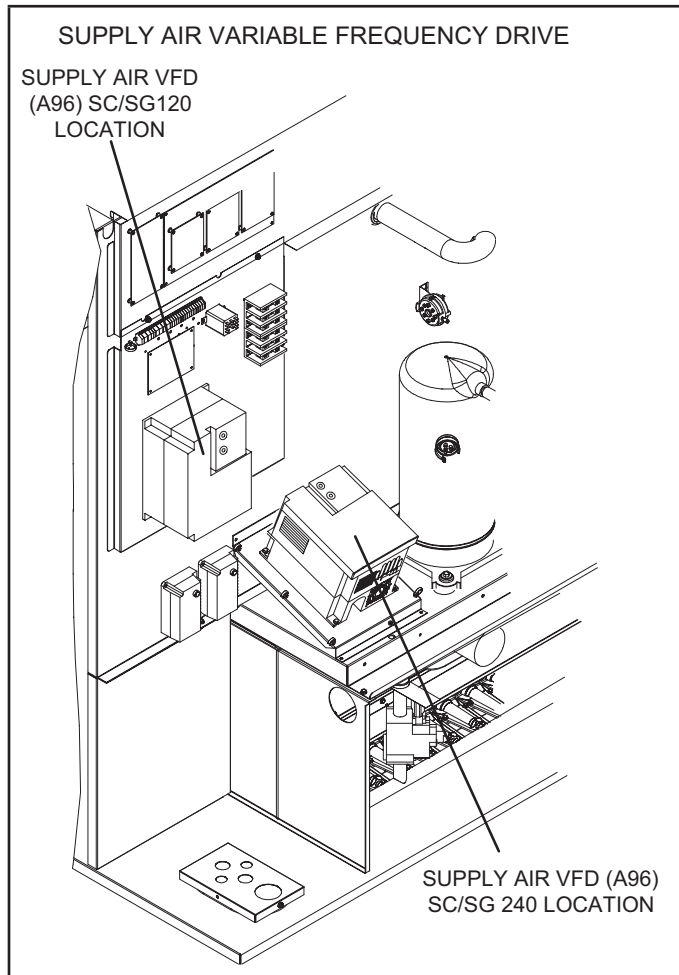

FIGURE 38

A-Design Specifications

Use TABLE 17 to fill in field-provided, design specified blower CFM for appropriate unit.

If only high and low cooling design specifications are provided, set the medium cooling CFM at the high or low cooling design spec or any CFM between.

B-Set Maximum CFM

Use TABLE 18 to determine highest blower CFM for appropriate unit. Adjust the blower pulley to deliver that amount of CFM with only the blower operating. See *Determining Unit CFM* in the Blower Operation and Adjustment section.

C-Enter Design Specifications Into Controller

- 1 - Use the following menu to enter the blower design specified CFM into the Unit Controller. Make sure blower CFM is within limitations shown in TABLE 18. Refer to the Unit Controller manual provided with unit.

TEST & BALANCE > BLOWER (enter information as prompted by the Unit Controller if not already done).

- 2 - Enter the following design specifications as shown.
Blower / Heat CFM
Cooling High CFM¹
Cooling Low CFM¹
Vent CFM

¹The Unit Controller will prompt when more cooling stages are available depending on the number of compressors and the control mode.

- 3 - Adjust the blower RPM to deliver the target CFM based on the measured static pressure using the blower table.
- 4 - Measure the static pressure again and apply the static pressure and RPM to the tables to determine adjusted CFM.
- 5 - Repeat adjustments until design CFM is reached.

D-Set Damper Minimum Position

To maintain required minimum ventilation air volumes when the unit is in the occupied mode, two minimum damper positions must be set. The Unit Controller will open the dampers to “Min OCP Blwr Low” when blower CFM is BELOW a “midpoint” CFM. The Unit Controller will open the damper to “Min OCP Blwr High” when blower CFM is at or ABOVE the “midpoint” CFM.

The Unit Controller will calculate the “midpoint” CFM.

Set Minimum Position 1

Use the following menu in the Unit Controller to set “Min OCP Blwr Low” for the blower CFM below the “midpoint” CFM. When navigating into this menu, the Unit Controller will bring on the corresponding blower speed and allow damper position adjustment.

RTU OPTION > DAMPER > MIN DAMPER POSITION BLOWER ON HIGH = X.X%

TABLE 17
Blower CFM Design Specifications

Unit	T'Stat or Zone Control Stages	Blower Speed	Design Specified CFM
120, 240	2	Htg.	
		Clg. High	
		Clg. Low	
		Ventilation	
240	4	Htg.	
		Clg. High	
		Clg. Med. High	
		Clg. Med. Low	
		Clg. Low	
		Ventilation	

^{*}Available blower speeds vary by unit and thermostat stages

Measure the intake air CFM. If the CFM is lower than the design specified CFM for ventilation air, use the Unit Controller to increase the damper percent open. If the CFM is higher than specified, decrease the damper percent open.

NOTE - Intake air CFM can also be determined using the outdoor air temperature, return air temperature and mixed air temperature. Refer to the economizer or outdoor air damper installation instructions.

**TABLE 18
MINIMUM AND MAXIMUM CFM**

Electric Heat Minimum CFM		
Unit	Heat Size (kW)	Airflow CFM
SC 120	0, 15, 20, 30, 40, 45, 60	3800
SC 240	0, 20, 30, 40, 60, 80, 90	8000
Cooling Minimum CFM - 220 CFM/ton		
Unit	Blower Speed	Airflow CFM
SC 120	Low, Med. Low, Med. High	2200
SC 240	Low, Med. Low, Med. High	4400
Cooling Minimum CFM - 280 CFM/ton		
Unit	Blower Speed	Airflow CFM
SC 120	High	2800
SC 240	High	5600
Smoke and Ventilation Minimum CFM - 150 CFM/ton		
Unit	Not Applicable	Airflow CFM
SC 120	NA	1500
SC 240	NA	3000
Heating and Cooling Maximum CFM - 480 CFM/ton		
Unit	Blower Speed	Airflow CFM
SC 120	High	4800
SC 240	High	9600

Set Minimum Position 2

Use the same menu in the Unit Controller to set "Min OCP Blwr High" for the blower CFM above the "midpoint" CFM. When navigating into this menu, the Unit Controller will bring on the corresponding blower speed and allow damper position adjustment.

Settings / Control / MSAV / Damper / High Speed

Measure the intake air CFM. If the CFM is lower than the design specified CFM for ventilation air, use the Unit Controller to increase the damper percent open. If the CFM is higher than specified, decrease the damper percent open.

NOTE - Intake air CFM can also be determined using the outdoor air temperature, return air temperature and mixed air temperature. Refer to the economizer or outdoor air damper installation instructions.

This is a summary of cooling operation. Refer to the sequence of operation provided in the Engineering Handbook or Service Manual for more detail.

A-Two-Stage T'Stat; 2 and 4-Compressor Units

1 - Economizer With Outdoor Air Suitable

Y1 Demand -
Compressors Off
Blower Cooling Low
Dampers modulate

Y2 Demand -
Compressors Off
Blower Cooling High
Dampers Modulate

NOTE - If dampers are at maximum open for three minutes, compressor 1 and 2 are energized and blower stays on cooling high.

2 - No Economizer or Outdoor Air Not Suitable

Y1 Demand -
First-stage Compressors On (compressor 1 on 120 units, compressor 1 & 2 on 240 units)
Blower Cooling Low
Dampers Minimum Position

Y2 Demand -
All Compressors On
Blower Cooling High
Dampers Minimum Position

B-Zone Sensor (4 Clg. Stages), 4-Compressor Units (240 Units)

1 - Economizer with Outdoor Air Suitable

Y1 Demand -
Compressors Off
Blower Cooling Medium High
Dampers modulate

Y2 Demand -
Compressors Off
Blower Cooling High
Dampers Modulate

NOTE - If dampers are at maximum open for three minutes, compressor 1 is energized and blower stays on cooling high.

Y3 Demand -
Compressors 1 and 2 On
Blower Cooling High
Dampers Maximum Open

Y4 Demand -
All Compressors On
Blower Cooling High
Dampers Maximum Open

2 - No Economizer or Outdoor Air Not Suitable

Y1 Demand -
Compressor 1 On
Blower Cooling Low

Y2 Demand -
Compressor 1 and 2 On
Blower Cooling Medium Low

Y3 Demand -
Compressors 1, 2, and 3 On
Blower Cooling Medium High

Y4 Demand -
All Compressors On
Blower Cooling High

E-Unit Operation

Use the mobile app to check unit mechanical operation. See the Service - Test section of the Unit Controller manual.

F-Manual Supply Air VFD Bypass

IMPORTANT - All dampers must be open to prevent damage to duct work and dampers.

Note - This section does not apply to units equipped with optional automatic VFD bypass. That option will automatically change from multi-stage air volume to constant air volume operation in the event of VFD failure.

Manually change blower operation to constant air volume as follows:

- 1 - Disconnect all power to unit and **WAIT AT LEAST 10 MINUTES** before opening the VFD cover.

⚠ WARNING

ELECTRICAL SHOCK HAZARD.

STOP! Before you continue, make sure that power to the VFD has been off for at least 10 minutes. The capacitor in the VFD holds high voltage power for up to 10 minutes after power has been disconnected.

- 2 - Locate P246 and P247 connectors near the VFD. See FIGURE 39.
- 3 - Disconnect P246 from P246 (power in to VFD) and P247 from P247 (power out to blower). See FIGURE 40.
- 4 - Connect P246 to P247. See FIGURE 41.

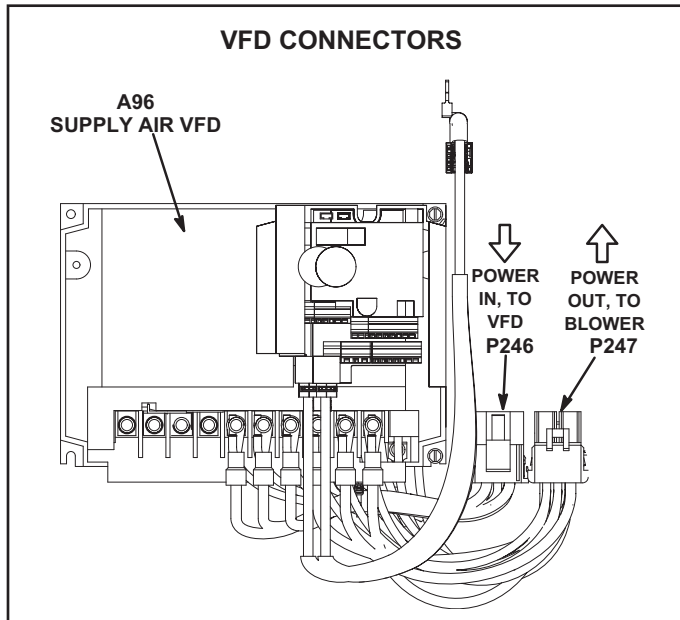

FIGURE 39

- 5 - Restore power to unit. Blower will operate in constant air volume (CAV) mode.

Note - The indoor blower motor will start as soon as the main unit power is restored. In manual bypass, the blower will run regardless of thermostat signals until main unit power is turned off. Manual bypass is meant for emergency operation only and not long-term usage.

- 6 - Check the indoor blower motor nameplate for full load amperage (FLA) value. Measure the amp readings from the indoor blower motor operating in bypass mode. If measured amps are higher than nameplate FLA value, decrease the CFM by opening (turning counterclockwise) the motor pulley. See FIGURE 19 or FIGURE 20. Do not exceed minimum and maximum number of pulley turns as shown in table 3.

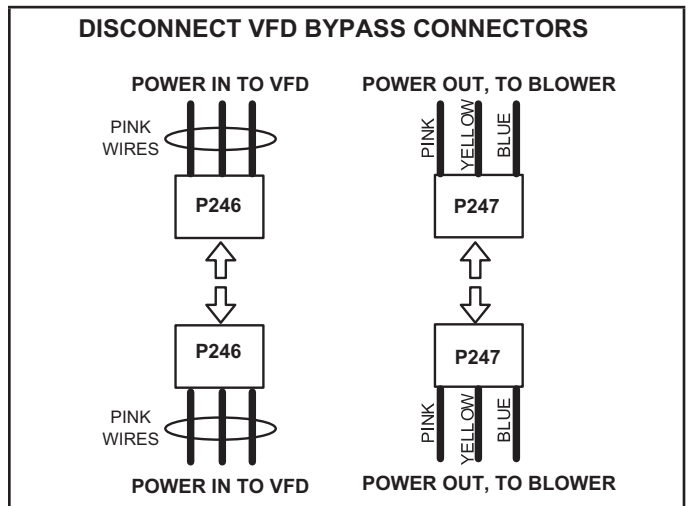

FIGURE 40

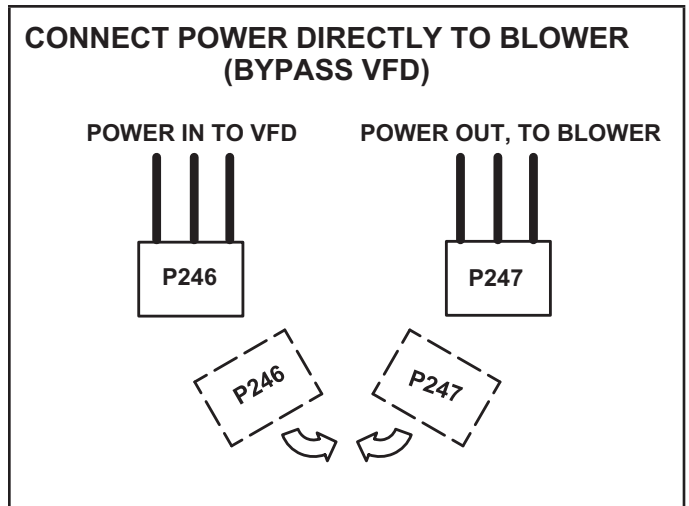

FIGURE 41

VIII-Decommissioning

Before carrying out this procedure, it is essential that the technician is completely familiar with the equipment and all its detail. It is recommended good practice that all refrigerants are recovered safely. Prior to the task being carried out, an oil and refrigerant sample shall be taken in case analysis is required prior to re-use of recovered refrigerant. It is essential that electrical power is available before the task is commenced.

Steps to ensure this are:

- Become familiar with the equipment and its operation,
- Isolate the system electrically,
- Ensure that before attempting the procedure that mechanical handling equipment is available, if required, for handling refrigerant cylinders, and that all personal protective equipment is available and being used correctly while the recovery process is supervised at all times by a competent person and that the recovery equipment and cylinders conform to the appropriate standards.

Additionally, pump down refrigerant system, if possible, and if a vacuum is not possible, make a manifold so that refrigerant can be removed from various parts of the system. Make sure that cylinders are situated on the scales before recovery takes place. Start the recovery machine and operate in accordance with instructions. Do not overfill cylinders (no more than 80 % volume liquid charge). Do not exceed the maximum working pressure of the cylinder, even temporarily. When the cylinders have been filled correctly and the process completed, make sure that the cylinders and the equipment are removed from site promptly and all isolation valves on the equipment are closed off. Recovered refrigerant shall not be charged into another refrigerating system unless it has been cleaned and checked.

Equipment shall be labeled stating that it has been decommissioned and emptied of refrigerant. The label shall be dated and signed. For appliances containing flammable refrigerants, ensure that there are labels on the equipment stating the equipment contains flammable refrigerant.

Under no circumstances shall potential sources of ignition be used in the searching for or detection of refrigerant leaks. A halide torch (or any other detector using a naked flame) shall not be used. Electronic leak detectors may be used to detect refrigerant leaks but, in the case of flammable refrigerants, the sensitivity may not be adequate, or may need re-calibration. (Detection equipment shall be calibrated in a refrigerant-free area)

Ensure that the detector is not a potential source of ignition and is suitable for the refrigerant used. Leak detection equipment shall be set at a percentage of the LFL of the refrigerant and shall be calibrated to the refrigerant employed, and the appropriate percentage of gas (25 % maximum) is confirmed. Leak detection fluids are also suitable for use with most refrigerants but the use of detergents containing chlorine shall be avoided as the chlorine may react with the refrigerant and corrode the copper pipe-work. If a leak is suspected, all naked flames shall be removed/extinguished. If a leakage of refrigerant is found which requires brazing, all of the refrigerant shall be recovered from the system, or isolated (by means of shut off valves) in a part of the system remote from the leak.

When breaking into the refrigerant circuit to make repairs – or for any other purpose – conventional procedures shall be used. However, for flammable refrigerants it is important that best practice be followed, since flammability is a consideration. The following procedure shall be adhered to:

- Safely remove refrigerant following local and national regulations,
- Evacuate the circuit,
- Purge the circuit with inert gas,
- Evacuate,
- Purge with inert gas,
- Open the circuit.

The refrigerant charge shall be recovered into the correct recovery cylinders if venting is not allowed by local and national codes. For appliances containing flammable refrigerants, the system shall be purged with oxygen-free nitrogen to render the appliance safe for flammable refrigerants. This process might need to be repeated several times. Compressed air or oxygen shall not be used for purging refrigerant systems. Refrigerant purging shall be achieved by breaking the vacuum in the system with oxygen-free nitrogen and continuing to fill until the working pressure is achieved, then venting to atmosphere, and finally pulling down to a vacuum. This process shall be repeated until no refrigerant is within the system. When the final oxygen-free nitrogen charge is used, the system shall be vented down to atmospheric pressure to enable work to take place. Ensure that the outlet for the vacuum pump is not close to any potential ignition sources and that ventilation is available.

IX-Wiring Diagrams and Sequence of Operation

Thermostat

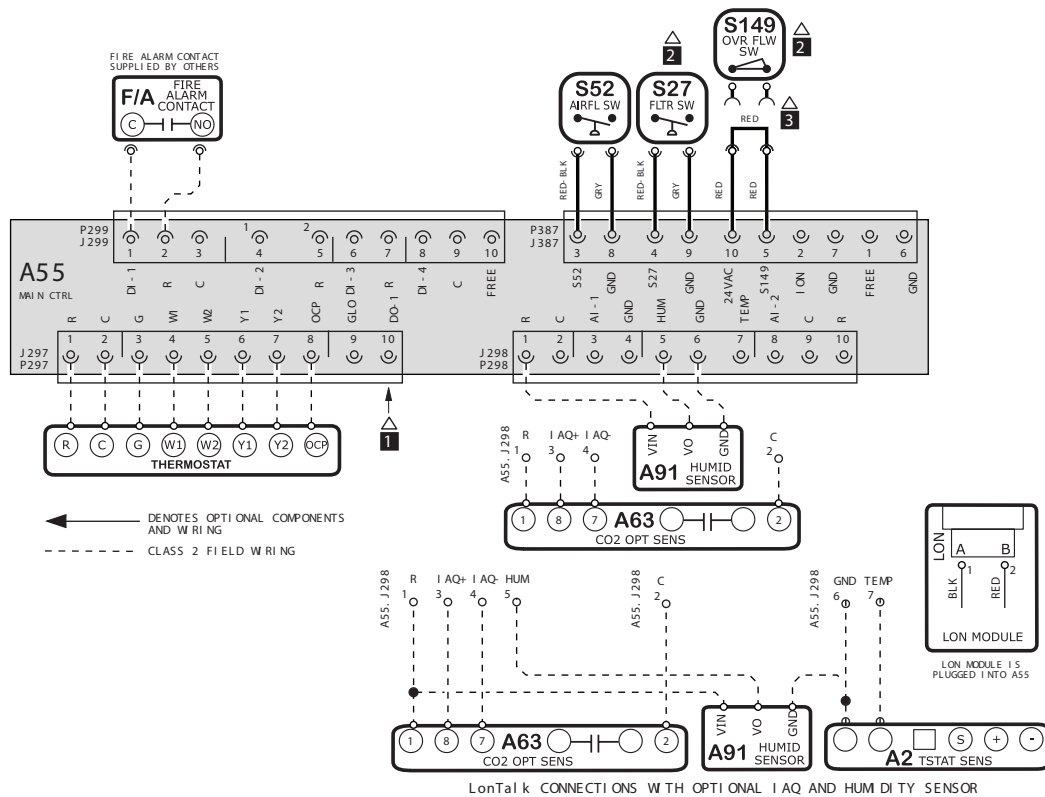

KEY LIST		
LOCATION		COMPONENT DESCRIPTION
FF05	A2	SENSOR, ELECTRONIC THERMOSTAT
AA03	A55	CONTROL BOARD, MAIN
DD04/05	A63	SENSOR, CO2 (IAQ)
DD04/05	A91	SENSOR, HUMIDITY
AA01	F/A	FIRE ALARM CONTACT
DD01	S27	SWITCH, FILTER
DD01	S52	SWITCH, AIRFLOW
EE01	S149	SWITCH, OVERFLOW ONE

NOTES	
1	P297-10 (SR) IS SERVICE RELAY OUTPUT (24VAC) IF USED CONNECT TO AN INDICATOR LIGHT
2	CORE CONTROLLER SETTINGS MUST BE MODIFIED WHEN S27, S149 ARE INSTALLED
3	REMOVE JUMPER TO INSTALL S149

Model: SC, SG Series RTU
 Thermostat and LonTalk
 Voltage: All Voltages
 Supersedes: N/A Form No: 538391-01 Rev: 0

Economizer

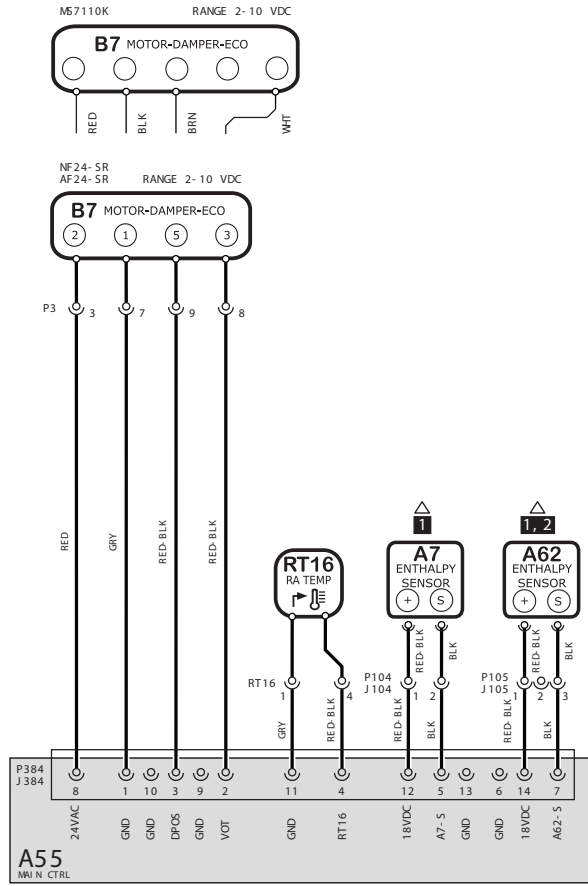

NOTES	
1	A7 AND A62 NOT USED FOR SENSIBLE TEMPERATURE CONTROL
2	FOR UNIT DIFFERENTIAL ENTHALPY CONTROL, ADD A62 RETURN AIR ENTHALPY SENSOR

KEY LIST	
LOCATION	COMPONENT DESCRIPTION
CC05	A7 SENSOR, SOLID STATE ENTHALPY
AA06	A55 CONTROL BOARD, MAIN
DD05	A62 SENSOR, ENTHALPY INDOOR
BB02	B7 MOTOR, DAMPER ECONOMIZER
CC05	RT16 SENSOR, RETURN AIR TEMP

Model: LC,LG,LH,LD,SC,SG Series
Economizer & Motorized OAD
Voltage: All Voltages
Supersedes: N/A

© 2019 ▼

HTG SEC A	CLG SEC B	CLG SEC B3	ACCS SEC C	ACCS SEC D
-----------------	-----------------	------------------	------------------	------------------

WIRING DIAGRAM FLOW

Form No: 538072- 01 Rev: 2

EHA-10, 15, 20, 30 - G & 15, 30 - J

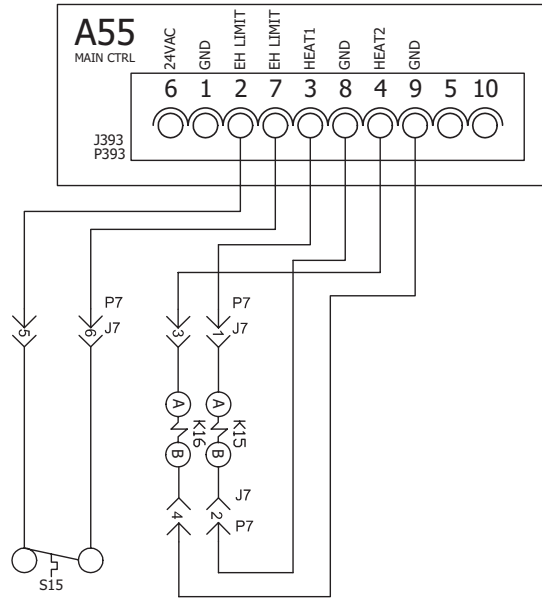

KEY	DESCRIPTION
A55	PANEL, MAIN
CB10	CIRCUIT BREAKER, MAIN DISCONNECT
F3	FUSE, ELECTRIC HEAT
F4	FUSE, UNIT
F42	FUSE, ELECTRIC HEAT 2 (30 KW ONLY)
HE1	ELEMENT, ELECTRIC HEAT 1
HE2	ELEMENT, ELECTRIC HEAT 2
J7	JACK, ELECTRIC HEAT
K15,-1	CONTACTOR, ELECTRIC HEAT 1
K16,-1	CONTACTOR, ELECTRIC HEAT 2
P7	PLUG, ELECTRIC HEAT
S15	SWITCH LIMIT PRIMARY ELECTRIC HEAT
S20	SWITCH LIMIT SECONDARY ELECTRIC HEAT 1
S157	SWITCH LIMIT SECONDARY ELECTRIC HEAT 2
TB3	TERMINAL STRIP, ELECTRIC HEAT

TB3 IS USED ON SOME UNITS

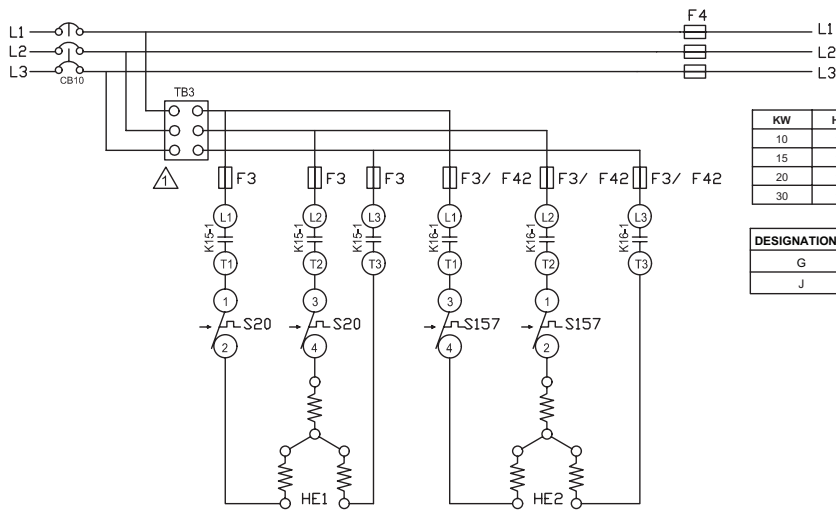

KW	HE1	HE2
10	10	
15	15	
20	10	10
30	15	15

DESIGNATION	VOLTAGE
G	460/60/3
J	575/60/3

DENOTES OPTIONAL COMPONENTS

	STRATEGOS WIRING DIAGRAM 538471-01	04/24
	HEATING	
ELECTRIC HEAT FOR STRATEGOS™ EHA/EHB - 10,15,20,30 - G & 15,30-J		
SECTION A		
Supersedes 537474-01	New Form No. 538471-01	
© 2024	Lennox Commercial	

EHA 40, 45, 60 - G & 45, 60 - J

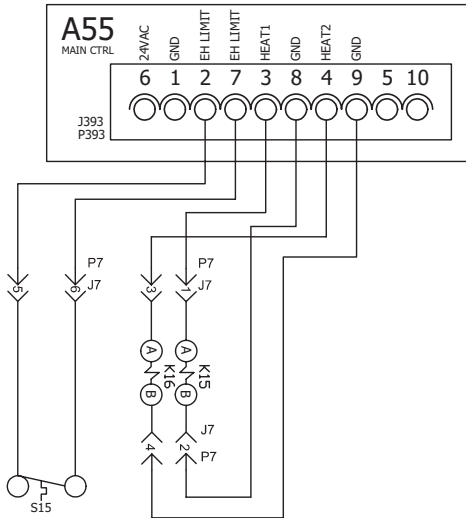

KEY	DESCRIPTION
A55	CONTROL, BOARD LENNOX
CB10	CIRCUIT BREAKER, MAIN DISCONNECT
F3	FUSE, ELECTRIC HEAT 1, 2
F42	FUSE, ELECTRIC HEAT 3, 4
F4	FUSE, UNIT
HE1	ELEMENT, ELECTRIC HEAT 1
HE2	ELEMENT, ELECTRIC HEAT 2
HE3	ELEMENT, ELECTRIC HEAT 3
HE4	ELEMENT, ELECTRIC HEAT 4
J7	JACK, ELECTRIC HEAT SUB-BASE KIT
K15,-1	CONTACTOR, ELECTRIC HEAT 1.2
K16,-1	CONTACTOR, ELECTRIC HEAT 1A.2A
P7	PLUG, ELECTRIC HEAT SUB-BASE KIT
S15	SWITCH, LIMIT PRIMARY ELECTRIC HEAT
S20	SWITCH, LIMIT SECONDARY ELECTRIC HEAT 1.2
S158	SWITCH, LIMIT SECONDARY ELECTRIC HEAT 2A
TB3	TERMINAL STRIP, ELECTRIC HEAT

KW	HE1	HE2	HE3	HE4
40	10	10	10	10
45	15		15	15
60	15	15	15	15

DESIGNATION	VOLTAGE
G	460/60/3
J	575/60/3

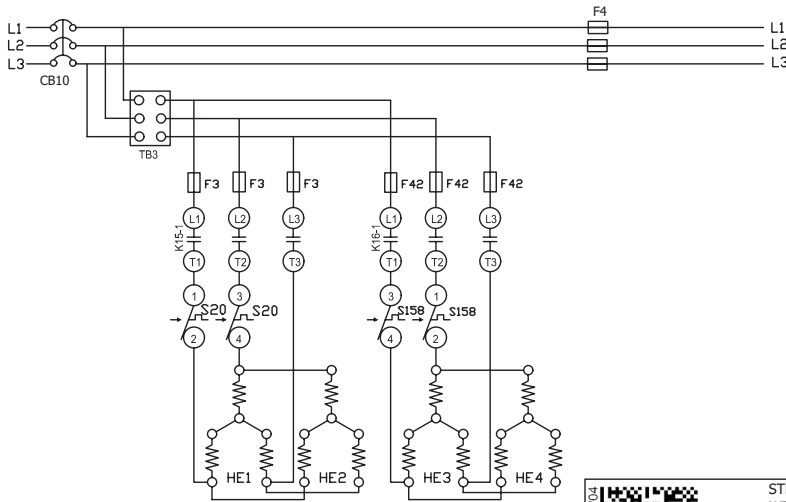

← DENOTES OPTIONAL COMPONENTS

	STRATEGOS WIRING DIAGRAM 538473-01	04/24
	HEATING ELECTRIC HEAT FOR STRATEGOS™ EHA/EHB - 40,45,60 - G & 45,60 - J	
SECTION A		REV 0
Supersedes 537475-01	New Form No. 538473-01	
© 2024		Lennox Commercial

EHA-15, 30, 45, 60, 90 - G & J

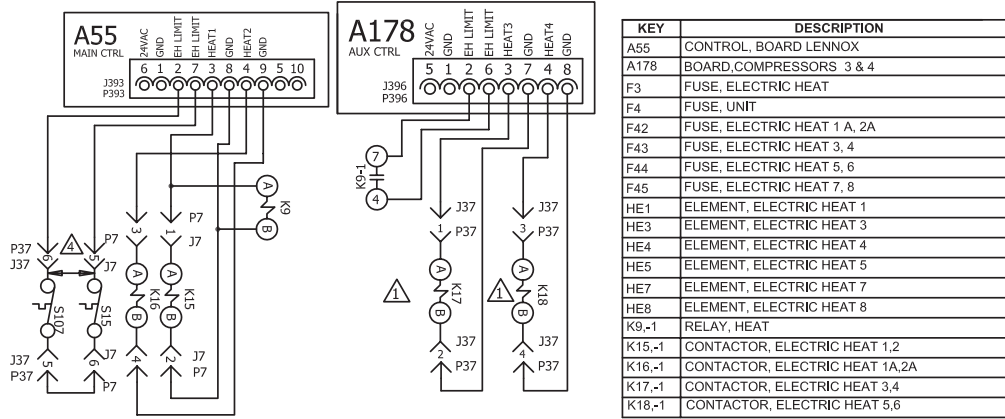

KEY	DESCRIPTION
A55	CONTROL, BOARD LENNOX
A178	BOARD, COMPRESSORS 3 & 4
F3	FUSE, ELECTRIC HEAT
F4	FUSE, UNIT
F42	FUSE, ELECTRIC HEAT 1 A, 2A
F43	FUSE, ELECTRIC HEAT 3, 4
F44	FUSE, ELECTRIC HEAT 5, 6
F45	FUSE, ELECTRIC HEAT 7, 8
HE1	ELEMENT, ELECTRIC HEAT 1
HE3	ELEMENT, ELECTRIC HEAT 3
HE4	ELEMENT, ELECTRIC HEAT 4
HE5	ELEMENT, ELECTRIC HEAT 5
HE7	ELEMENT, ELECTRIC HEAT 7
HE8	ELEMENT, ELECTRIC HEAT 8
K9-1	RELAY, HEAT
K15-1	CONTACTOR, ELECTRIC HEAT 1,2
K16-1	CONTACTOR, ELECTRIC HEAT 1A,2A
K17-1	CONTACTOR, ELECTRIC HEAT 3,4
K18-1	CONTACTOR, ELECTRIC HEAT 5,6

S15	SWITCH, LIMIT PRIMARY ELECTRIC HEAT
S20	SWITCH, LIMIT SECONDARY ELECTRIC HEAT 1,2
S107	SWITCH, PRIMARY ELECTRIC HEAT
S157	SWITCH, LIMIT SECONDARY ELECTRIC HEAT 1A
S158	SWITCH, LIMIT SECONDARY ELECTRIC HEAT 2A
S159	SWITCH, LIMIT SECONDARY ELECTRIC HEAT 3,4
S160	SWITCH, LIMIT SECONDARY ELECTRIC HEAT 5,6
TB2	TERMINAL STRIP, UNIT
TB3	TERMINAL STRIP, ELECTRIC HEAT

J/P	DESCRIPTION
7	ELECTRIC HEAT CONTROL
37	ELECTRIC HEAT CONTROL

DESIGNATION	VOLTAGE
G	460/60/3

- ⚠ NOT USED ON 15 AND 30KW UNITS
- ⚠ TB3 IS USED IN SOME UNITS
- ⚠ TB2, S48 OR CB10 MAY BE USED
- ⚠ REMOVE JUMPER PLUG WHEN FIELD INSTALLING ELECTRIC HEAT
- ⚠ F61 USED ON UNITS WITH SCCR OPTION
- ⚠ TB2 IS USED IN SOME SCCR OPTION UNITS ONLY

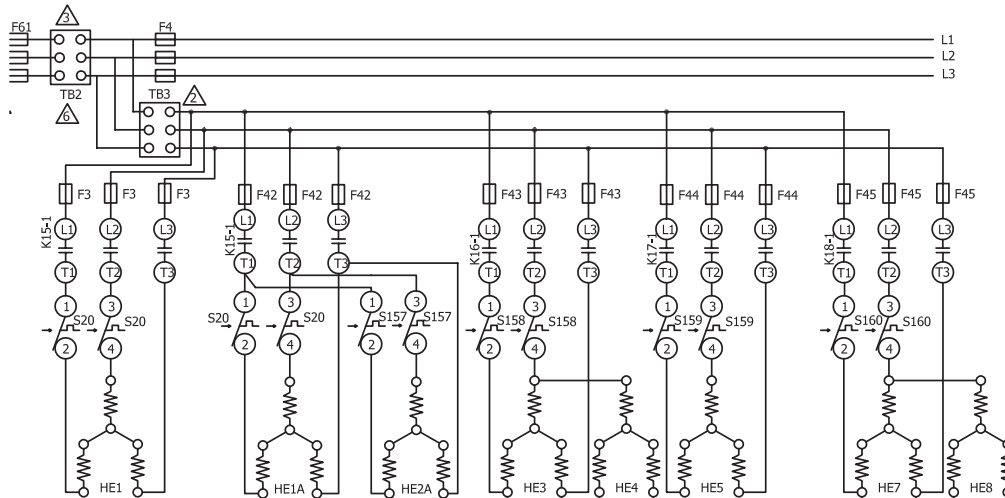

KW	HE1	HE1A	HE2A	HE3	HE4	HE5	HE7	HE8
15		7.5	7.5					
30		15	15					
45	15			7.5		15	7.5	
60	15			15		15	15	
90	15			15	15	15	15	15

← DENOTES OPTIONAL COMPONENTS

2021/09	WIRING DIAGRAM 538126-02	9/21
HEATING ELECTRIC HEAT E1EH,EHA-15,30,45,60,90 - G, J		
SECTION A		REV.0
Supersedes	New Form No.	
538126-01	538126-02	

SEQUENCE OF OPERATION
EHA-15, 30, 45, 60, 90 - G & J

NOTE: Two electric heat sections are used in all 15kW through 90kW heaters. The heat sections are labelled first electric heat section (left side) and second electric heat section (right side). See FIGURE 18.

NOTE: In the case of EHA 15 and 30kW, the second heat section (right side) is a slave (only has electric heat elements and a limit). Line voltage is supplied to elements in both heat section one (left side) and two (right side) by the contactors in heat section one (left side).

HEATING ELEMENTS:

- 1 - Terminal strip TB3 is energized when the unit disconnect closes. TB3 supplies line voltage to electric heat elements HE1 through HE14. Each heating element is protected by fuse F3.

FIRST STAGE HEAT:

- 2 - Heating demand initiates at W1 in thermostat.
- 3 - 24VAC is routed to the main control module A55. After A55 proves N.C. primary limits S15 (heat section one, left side), S107 (heat section two, right side), the electric heat contactor K15 and heat relay K9 are energized.
- 4 - N.O. contact K15-1 closes allowing the first bank of elements in heat section one (left side) to be energized.
- 5 - At the same time, N.O. contacts K9-1 close. A N.O. contact in A55 closes, energizing electric heat relay K17.
- 6 - N.O. contacts K17-1 close allowing the first set of elements in heat section two (right side) to be energized

SECOND STAGE HEAT:

- 7 - With the first stage heat operating, an additional heating demand initiates at W2 in the thermostat.
- 8 - 24VAC is routed through the main control module A55, which in turn energizes the electric heat contactor K16.
- 9 - N.O. contacts K16-1 close allowing the second set of elements in heat section one (left side) to be energized.
- 10 - Simultaneous with step eight, a N.O. contact in the A55 Unit controller closes, allowing 24VAC to energize electric heat contactor K18.
- 11 - N.O. contacts K18-1 close allowing the second set of elements in heat section two (right side) to be energized.

END OF SECOND STAGE HEAT:

- 12 - Heating demand is satisfied. Terminal W2 in the thermostat is de-energized.
- 13 - Electric heat contactors K16 and K18 are de-energized.
- 14 - The second set of electric heat elements in heat sections one (left side) and two (right side) are de-energized.

END OF FIRST STAGE HEAT:

- 15 - Heating demand is satisfied. Terminal W1 in the thermostat is de-energized.
- 16 - Electric heat contactors K15 and K17 are de-energized.
- 17 - The first set of electric heat elements in heat sections one (left side) and two (right side) are de-energized

Power Entry

----- POWER ENTRY OPTI ONS -----

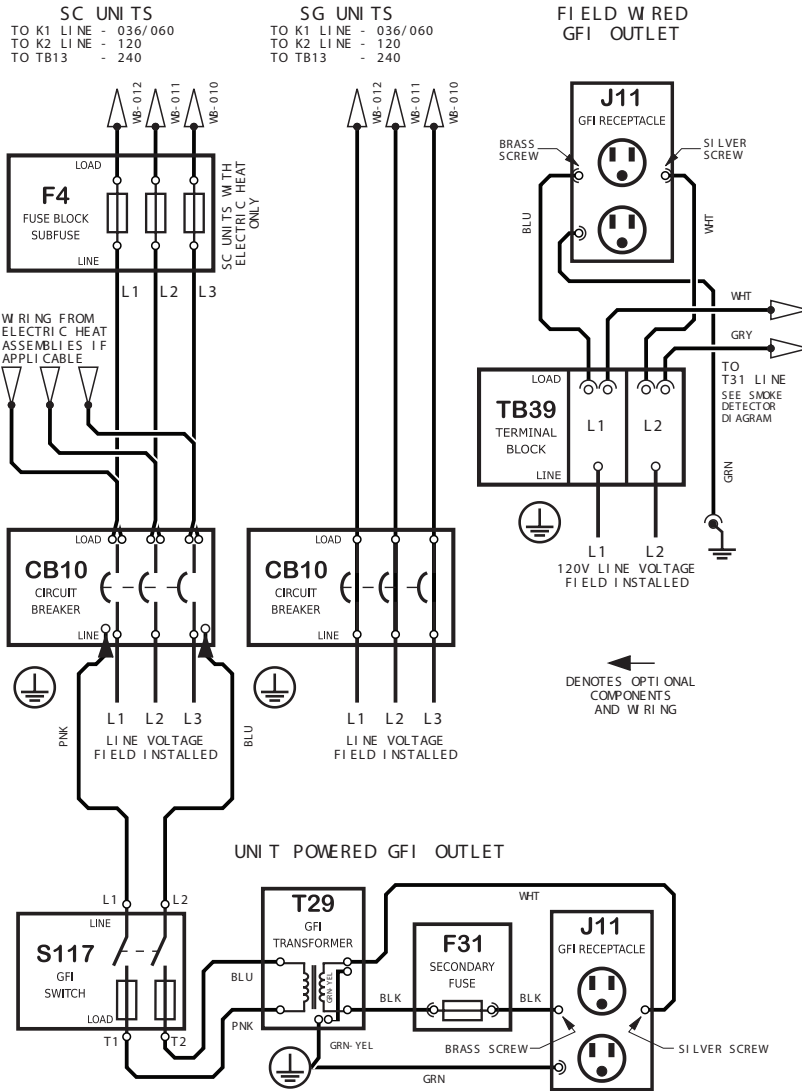

Model: SC, SG Series K1U
 Power Entry Options
 Voltage: All Voltages
 Supersedes: 538103-01 FORM NO. 538469-01 Rev: 0

SCH120 Schematic

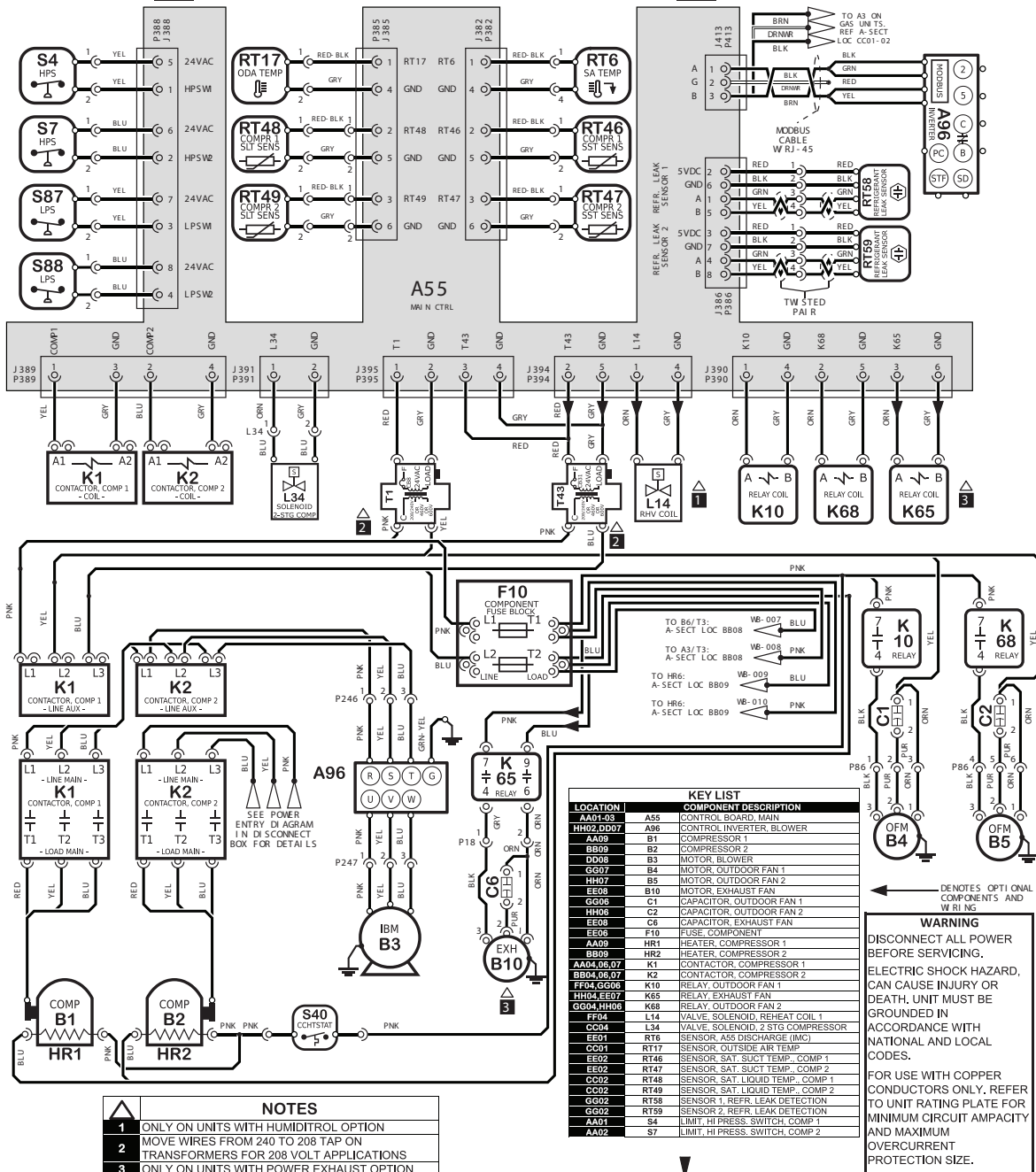

- NOTES**
- 1 ONLY ON UNITS WITH HUMIDITROL OPTION
 - 2 MOVE WIRES FROM 240 TO 208 TAP ON TRANSFORMERS FOR 208 VOLT APPLICATIONS
 - 3 ONLY ON UNITS WITH POWER EXHAUST OPTION

Model: SC, SG - 120H
COOLING
Voltage: All Voltages
Supersedes: XXXXX-XX Form No: 538406-01 Rev: 000

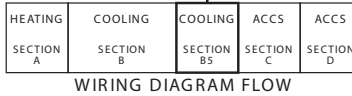

SCH240 Schematic

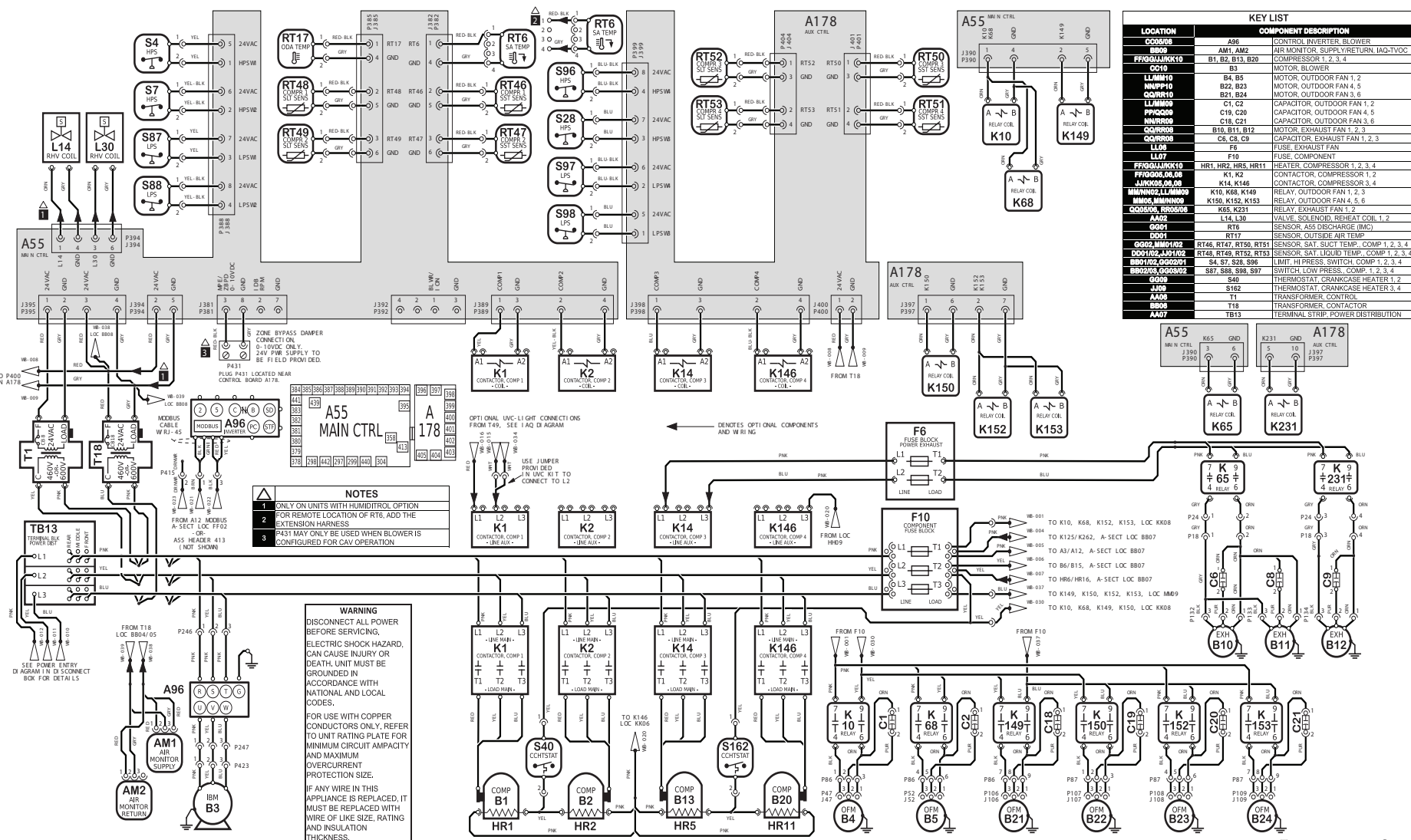

KEY LIST	
LOCATION	COMPONENT DESCRIPTION
Q0006	A96 CONTROL INVERTER, BLOWER
Q0007	AM1, AM2 AIR MONITOR, SUPPLY RETURN, IAG-IVOC
FF00LLINK10	B1, B2, B3, B20 COMPRESSOR 1, 2, 3, 4
CO10	B3 MOTOR, BLOWER
LL1MM10	B4, B5 MOTOR, OUTDOOR FAN 1, 2
NN1FF10	B22, B23 MOTOR, OUTDOOR FAN 4, 5
CO0R10	B21, B24 MOTOR, OUTDOOR FAN 3, 6
LL1MM10	C1, C2 CAPACITOR, OUTDOOR FAN 1, 2
FF00Q00	C19, C20 CAPACITOR, OUTDOOR FAN 4, 5
NN1FF10	C18, C21 CAPACITOR, OUTDOOR FAN 3, 6
CO0R00	B10, B11, B12 MOTOR, EXHAUST FAN 1, 2, 3
CO0R00	C6, C8, C9 CAPACITOR, EXHAUST FAN 1, 2, 3
LL00	F6 FUSE, EXHAUST FAN
LL00	F10 FUSE, COMPONENT
FF00LLINK10	HR1, HR2, HR5, HR11 HEATER, COMPRESSOR 1, 2, 3, 4
FF00Q00, Q0006	K1, K2 CONTACTOR, COMPRESSOR 1, 2
FF00Q00, Q0006	K14, K16 CONTACTOR, COMPRESSOR 3, 4
NN1FF10	K10, K68, K149 RELAY, OUTDOOR FAN 1, 2, 3
MM10C, LL1MM10	K150, K152, K153 RELAY, OUTDOOR FAN 4, 5, 6
Q0006, Q0006	K65, K231 RELAY, EXHAUST FAN 1, 2
CO10	L4, L30 VALVE, SOLENOID, REHEAT COIL 1, 2
Q0006	RT6 SENSOR, A55 DISCHARGE (IMC)
DD01	RT17 SENSOR, OUTSIDE AIR TEMP
Q002, MM10C	RT46, RT47, RT50, RT51 SENSOR, SAT SUCT TEMP, COMP 1, 2, 3, 4
DD01, RT17	RT48, RT49, RT52, RT53 SENSOR, SAT LIQUID TEMP, COMP 1, 2, 3, 4
BB01, RT17, Q0006	S4, S7, S28, S96 LIMIT, HI PRESS. SWITCH, COMP 1, 2, 3, 4
BB01, RT17, Q0006	S87, S88, S98, S97 SWITCH, LOW PRESS. COMP. 1, 2, 3, 4
CO10	S40 THERMOSTAT
MM10C	S162 THERMOSTAT, CRANKCASE HEATER 3, 4
A005	T1 TRANSFORMER, CONTROL
FF00	T18 TRANSFORMER, CONTACTOR
A007	TB13 TERMINAL STRIP, POWER DISTRIBUTION

- NOTES**
- ONLY ON UNITS WITH HUMIDITROL OPTION
 - FOR REMOTE LOCATION OF RT6, ADD THE EXTENSION HARNESS
 - P431 MAY ONLY BE USED WHEN BLOWER IS CONFIGURED FOR CAV OPERATION

WARNING
DISCONNECT ALL POWER BEFORE SERVICING. ELECTRIC SHOCK HAZARD, CAN CAUSE INJURY OR DEATH. UNIT MUST BE GROUNDED IN ACCORDANCE WITH NATIONAL AND LOCAL CODES.
FOR USE WITH COPPER CONDUCTORS ONLY. REFER TO UNIT RATING PLATE FOR MINIMUM CIRCUIT AMPACITY AND MAXIMUM OVERCURRENT PROTECTION SIZE.
IF ANY WIRE IN THIS APPLIANCE IS REPLACED, IT MUST BE REPLACED WITH WIRE OF LIKE SIZE, RATING AND INSULATION THICKNESS.

Model: SGH, SCH 240 - G, J-VOLT COOLING - MSAV

Voltage: 460V/3~60Hz (G), 575V/3~60Hz (J)
Supersedes: N/A Form No: 538448-01 Rev: 0

WIRING DIAGRAM FLOW

HEATING SECTION A	COOLING SECTION B	COOLING SECTION B3/5	ACCS SECTION C	ACCS SECTION D
-------------------	-------------------	----------------------	----------------	----------------

Sequence of Operation SCH120

Power:

- 1 - Line voltage through the S48 unit disconnect, TB2 terminal block, or CB10 circuit breaker energizes the T1 transformer. T1 provides 24VAC power to A55 Unit Controller which provides 24VAC to the unit cooling, heating and blower controls.
- 2 - Line voltage is also routed to compressor crankcase heaters, compressor contactors, the blower motor, condenser fan relays and exhaust fan relays.

Blower Operation:

- 3 - The A55 Unit Controller module receives a demand from thermostat terminal G.
- 4 - B3 receives the pre-set blower setting through MODUS.

Economizer Operation:

- 5 - A55 receives a demand and energizes exhaust fan relay K65 with 24VAC at 50% outside air damper open (adjustable).
- 6 - N.O. K65-1 and N.O. K65-2 both close, energizing exhaust fan motor B10.

1st Stage Cooling (compressor B1)

- 7 - A55 receives a Y1 thermostat demand.
- 8 - After A55 proves N.C. low pressure switch S87, RT46 reading above freeze point and N.C. high pressure switch S4, compressor contactor K1 is energized.
- 9 - N.O. contacts K1-1 close energizing compressor B1. Crankcase heater HR1 is de-energized.
- 10 - At the same time, A55 energizes condenser fan relays K10 and K68.
- 11 - N.O. contacts K10-1 close energizing condenser fan B4 and N.O. contacts K68-1 close energizing condenser fan B5.

2nd Stage Cooling (compressor B2 is energized)

- 12 - A55 receives a Y2 thermostat demand.
- 13 - After A55 proves N.C. low pressure switch S88, RT47 reading above freeze point, and N.C. high pressure switch S7, compressor contactor K2 is energized.
- 14 - N.O. contacts K2-1 close energizing compressor B2. Crankcase heater HR2 is de-energized.

3rd Stage Cooling (compressor B1 in full load and compressor 2 is energized)

- 15 - A55 receives a Y3 thermostat demand (Y1 + Y2 thermostat inputs).
- 16 - A55 sends 24VAC to B1 compressor solenoid (L14), B1 compressor runs at full load.

Sequence of Operation SCH240

- 1 - Line voltage from TB13 energizes transformer T1 and T18. Transformer T1 and T18 provides 24VAC power to the main controller A55. The transformers also provide 24VAC power to the unit cooling, heating and blower controls and thermostat.

ECONOMIZER OPERATION

- 2 - The A55 Unit Controller receives a demand and energizes exhaust fan relay K65 and K231 with 24VAC at 50% (travel) outside air damper open (adjustable).
- 3 - N.O. K65-1, K65-2, K231-01 and K231-02 close, energizing exhaust fan motors B10 and B11.

1ST STAGE COOLING

- 4 - First stage cooling demand energizes Y1 and G in the thermostat.
- 5 - 24VAC is routed to the A55 Unit Controller. After A55 proves N.C. low pressure switches S87, S88 and N.C. high pressure switches S4 and S7, compressor contactors K1 and K2 are energized.
- 6 - A55 energizes fan B21 directly and fans B4 & B5 through K10.
- 7 - N.O. K1 closes energizing compressor B1, and N.C. K1-52 opens de-energizing HR1, N.O. K2 closes energizing compressor B2, and N.C. K2-52 opens de-energizing HR2.

2ND STAGE COOLING

- 8 - Second stage cooling demand energizes Y2.
- 9 - N.O. contacts K14-1 close energizing compressor B13, de-energizing HR5.
- 10 - A178 energizes fan B24 directly and fans B22 & B23 through K150.
- 11 - N.O. K14 closes energizing compressor B13, and N.C. K14-52 opens de-energizing HR5.
- 12 - N.O. K146 closes energizing compressor B20, and N.C. K146-52 opens de-energizing HR11.

BLOWER OPERATION

With By Pass Installed - Active

- 1 - Main control A55 de-energizes relays K202 and K203
- 2 - K202 contacts open to interrupt power to B3 blower motor from A96 blower inverter.
- 3 - Main control A55 energizes relay K203-7.
- 4 - K203-1 N.C. contacts close allowing power to K3.
- 5 - K3 contacts close to allow power to B3 blower motor.

With By Pass Installed - Inactive

- 1 - Main control A55 energizes relays K202 and K203.
- 2 - K203-1 N.C. contacts open to de-energize K3 relay coil. K3 contacts open to interrupt power to B3 blower motor through K3 N.O. contacts.
- 3 - K202 contacts close to allow power to B3 blower motor from A96 blower inverter.

By-Pass Not Installed

- 1 - Control inverter A96 energizes B3.