

EL16KC1

ELITE® SERIES

Single-Stage | Quantum™ Coil | R-454B | 60Hz

RESIDENTIAL
PRODUCT SPECIFICATIONS (EHB)



1.5 to 5 Tons

SEER2 up to 17.0

Cooling Capacity | 17,000 to 59,000 Btuh

ELITE[®]
SERIES



2025 COMPLIANT
REFRIGERANT



MODEL NUMBER IDENTIFICATION

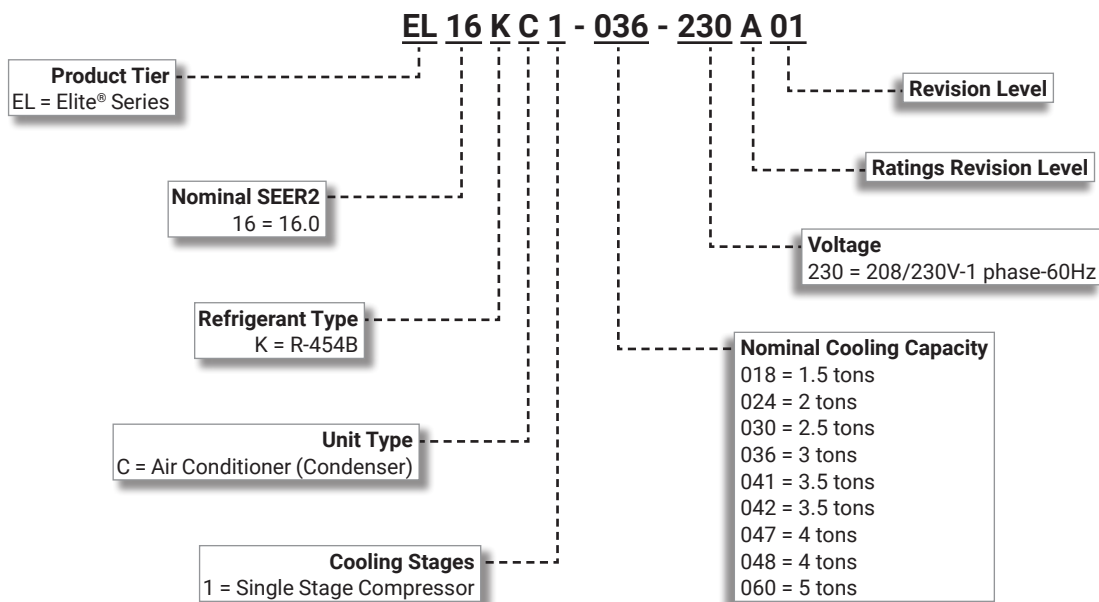

FEATURE HIGHLIGHTS

1. Outdoor Coil Fan
2. Quantum™ Coil
3. High Capacity Liquid Line Drier
4. High Pressure Switch
5. Low Pressure Switch
6. Scroll Compressor
7. Heavy Gauge Steel Cabinet
8. Louvered Coil Protection
9. Refrigerant Line Connections and Access

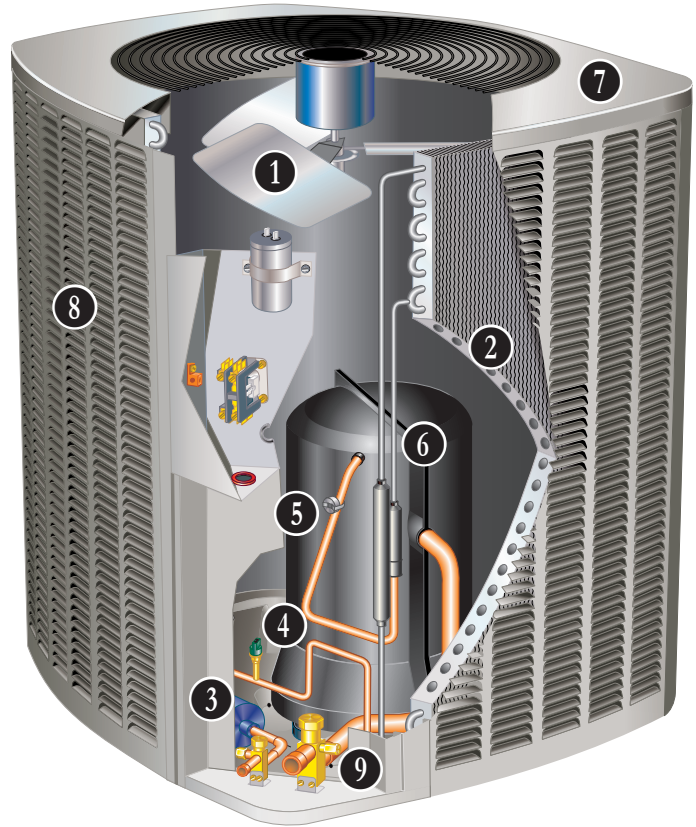

CONTENTS

Approvals And Warranty	3
Control Options	6
Dimensions - Unit	10
Electrical Data	7
Features	3
Field Wiring	9
Installation Clearances	9
Model Number Identification	1
Optional Accessories - Order Separately	7
Sound Data	9
Specifications	7
TXV Substitution - R-454B	11
TXV Usage	11

APPROVALS AND WARRANTY

APPROVALS

- AHRI Standard 210/240-2023 certified
- AHRI Certified system match-ups and expanded ratings, visit www.LennoxPros.com
- Sound rated to AHRI Standard 270-2008 test conditions
- Tested in Lennox' Research Laboratory environmental test room
- Rated According to U.S. Department of Energy (DOE) test procedures
- Unit and components ETL, NEC and CEC bonded for grounding to meet safety standards for servicing
- ETL certified (U.S. and Canada)
- ISO 9001 Registered Manufacturing Quality System

WARRANTY

- Compressor:
 - Limited ten years in residential installations
 - Limited five years in non-residential installations
- All other covered components:
 - Limited five years in residential installations
 - Limited one year in non-residential installations

NOTE - Refer to Lennox® Basic Limited Warranty at www.Lennox.com for additional details.

FEATURES

APPLICATIONS

- 1.5 through 5 tons
- Sound levels as low as 71 dBA
- Single-phase power supply
- Vertical air discharge
- Applicable to indoor air handlers or gas furnaces with indoor add-on coils
- Shipped completely factory assembled, piped and wired
- Factory test operated

REFRIGERATION SYSTEM

R-454B Refrigerant

- Low GWP (Global Warming Potential)
- Zero ODP (Ozone Depletion Potential)
- Low Toxicity/Lower Flammability - A2L
- Unit is factory pre-charged

NOTE - Total system refrigerant charge is dependent on outdoor unit size, indoor unit size and refrigerant line length.

NOTE - Refer to the unit-mounted charging sticker to determine correct amount of charge required.

1 Outdoor Coil Fan

- Direct drive fan
- Vertical air discharge
- Totally enclosed fan motor
- Ball bearings
- Inherently protected
- PVC (polyvinyl chloride) coated steel fan guard

2 Quantum™ Coil

- Lennox designed and fabricated coil
- Enhanced aluminum alloy tube/enhanced fin coil
- Superior corrosion resistance
- Ripple-edged aluminum fins
- Aluminum tube construction
- Lanced fins for maximum fin surface exposure
- Fin collars grip tubing for maximum contact area
- Flared shoulder tubing connections
- Factory tested under high pressure
- Entire coil is accessible for cleaning

3 High Capacity Liquid Line Drier

- Factory installed in the liquid line
- Drier traps moisture or dirt that could contaminate the system
- 100% molecular-sieve, bead type

4 High Pressure Switch

- Protects the system from high pressure conditions that can be a result of fan failure or a blocked/dirty coil
- Automatic reset

5 Low Pressure Switch

- Protects the compressor from low pressure conditions such as low refrigerant charge, or low/no indoor airflow
- Shuts off the outdoor unit if suction pressure falls below setting
- Automatic reset

FEATURES

REFRIGERATION SYSTEM (Continued)

Optional Accessories

Expansion Valve Kits

- Field installed on indoor units (if required)
- See TXV Usage table
- Chatleff-style fitting

Freezestat

- Protects the system from ice buildup on the indoor coil due to conditions such as low/no airflow, or low refrigerant charge
- Cycles compressor off when suction line temperature falls below freezestat setpoint
- Opens at 29°F and closes at 58°F
- Installs on or near the discharge line of the evaporator or on the suction line

Loss of Charge Switch Kit

- Protects compressor from damage from low/no refrigerant charge conditions
- SPST, normally-closed
- Automatic reset

Refrigerant Line Kits

- Refrigerant lines are shipped refrigeration clean
- Lines are cleaned, dried, pressurized and sealed at factory
- Suction line fully insulated
- Lines are stubbed at both ends

INDOOR REFRIGERANT DETECTION SYSTEM (RDS)

- Complies with UL 60335-2-40 approved standard
- Required for all systems using R-454B refrigerant
- Factory or field installed on all indoor units
- Consists of a RDS refrigerant detection sensor and a mitigation control in the indoor unit
- Ensures safe operation for systems equipped with R-454B refrigerant
- Indoor sensor will detect any R-454B refrigerant
- If R-454B refrigerant is detected, the refrigerant detection system will stop compressor operation and operate the blower to reduce concentrations in the conditioned space
- Once safe levels are reached the HVAC system will resume normal operation
- Refer to indoor unit Product Specifications documents for additional details

COMPRESSOR

6 Single-Stage Scroll Compressor

- High efficiency
- Uniform suction flow
- Constant discharge
- High volumetric efficiency
- Quiet operation
- Low gas pulses during compression reduces operational sound levels
- Compressor motor is internally protected from excessive current and temperature
- Muffler in discharge line reduces operating sound levels
- Compressor is installed in the unit on resilient rubber mounts for vibration free operation

Compressor Crankcase Heater (041 through 060 Models)

- Prevents migration of liquid refrigerant into compressor and ensures proper compressor lubrication

Compressor Sound Dampening System

- Polyethylene compressor
- 2 inch thick batt fiberglass insulation
- All open edges sealed with one-inch wide hook and loop fastening tape

Optional Accessories

Compressor Crankcase Heater (018 through 036 Models)

- Prevents migration of liquid refrigerant into compressor and ensures proper compressor lubrication

Compressor Hard Start Kit

- Single-phase units are equipped with a PSC compressor motor
- This type of motor normally does not need a potential relay and start capacitor
- For conditions such as low voltage kit may be required to increase the compressor starting torque

Compressor Low Ambient Cut-Off Switch

- Non-adjustable switch (low ambient cut-out)
- Prevents compressor operation when outdoor temperature is below 35°F

Compressor Timed-Off Control

- Prevents compressor short-cycling
- Allows time for suction and discharge pressure to equalize
- Permits compressor start-up in an unloaded condition
- Automatic reset with 5 minute delay between compressor shut-off and start-up

FEATURES

CABINET

- 7 • Heavy-gauge steel construction
- Pre-painted powder paint cabinet finish
- Louvered heavy gauge steel panels surround unit on all four sides
- Control box is conveniently located with all controls factory wired
- Corner patch plate allows access to compressor components
- Drainage holes are provided in base section for moisture removal
- High density polyethylene unit support feet raise the unit off of the mounting surface, away from damaging moisture

Zinc-Coated Steel Unit Base

- Resists rust and corrosion

8 **Louvered Coil Protection**

- Steel louvered panels provides complete coil protection
- Panels are hinged to allow easy cleaning and servicing of coils
- Panels may be completely removed
- Interlocking tabs and slots assure tight fit on cabinet



9 **Refrigerant Line Connections, Electrical Inlets and Service Valves**

- Sweat connection suction and liquid lines
- Located on corner of unit cabinet
- Suction valve can be fully shut off, while liquid valve may be front seated to manage refrigerant charge while servicing system
- Refrigerant line connections and field wiring inlets are located in one central area of the cabinet
- See dimension drawing

Braze-Free/Press Fitting Flexibility

- Units can accommodate braze-free or press fittings for installation versatility

CONTROLS

Optional Accessories

Thermostat

- Thermostat is not furnished with unit
- See page 6

Low Ambient Kit

- Air conditioners can operate down to 45°F outdoor air temperature without additional controls
- Allows unit to operate properly down to 30°F

NOTE - Crankcase heater and freezestat should be installed on compressors equipped with a low ambient kit.

NOTE - A compressor lock-out thermostat should be added to terminate compressor operation below recommended operation conditions.

CONTROL OPTIONS

E40 Smart Wi-Fi Thermostat

- 3 Htg.-2 Clg.
- 7-day, universal, programmable, touchscreen thermostat
- Controls dehumidification during cooling mode and humidification during heating mode
- Smooth Setback Recovery and compressor short-cycle protection
- One-Touch Away Mode, Smart Away™ (geo-fencing), equipment maintenance reminders and scheduling
- Smart home automation compatible with Amazon Alexa®, Google Assistant, Control4®, Building36® and Matter
- Lennox® Home App controls temperature, fan operation, set programs/schedules and set Away mode on a smartphone
- Lennox Smart Tech App allows the installer to commission the system and remotely turn the system on and off during setup or service call on a smartphone



M40 Smart Wi-Fi Thermostat

- 3 Htg.-2 Clg.
- 7-day, universal, programmable, touchscreen thermostat
- Smooth Setback Recovery and compressor short-cycle protection
- One-Touch Away Mode, Smart Away™ (geo-fencing), equipment maintenance reminders and scheduling
- Smart home automation compatible with Apple HomeKit™, Amazon Alexa®, Google Assistant and Matter
- Lennox® Home App controls temperature, fan operation, set programs/schedules and set Away mode on a smartphone
- Lennox Smart Tech App allows the installer to commission the system and remotely turn the system on and off during setup or service call on a smartphone



L40 Smart Wi-Fi Thermostat

- 2 Htg.-1 Clg.
- 7-day, universal, programmable, touchscreen thermostat
- Provides temperature control for gas, electric and heat pumps for single-stage heating or cooling systems (including dual-fuel operation)
- One-Touch Away Mode, Smart Away™ (geo-fencing), equipment maintenance reminders and scheduling
- Smooth Setback Recovery and compressor short-cycle protection
- Smart home automation compatible with Amazon Alexa®, Google Assistant, Control4®, Building36® and Matter
- Lennox® Home App controls temperature, fan operation, set programs/schedules and set Away mode on a smartphone
- Lennox Smart Tech App allows the installer to commission the system and remotely turn the system on and off during setup or service call on a smartphone



NOTE - Please refer to the individual Product Specifications for these products for full information.

CONTROLS - ORDERING

E40 Smart Wi-Fi Thermostat	3-3/8 x 5-3/8 x 1	30L26
Lennox® Smart Room Sensor	4 x 5-1/2 x 3	22V25
Lennox® Smart Air Quality Monitor	3-5/8 x 4-3/8 x 1-3/8	21P02
Lennox® Wireless Extender	4 x 5-1/2 x 2-1/2	22V26
L40 Smart Wi-Fi Thermostat	2-13/16 x 2-13/16 x 1/4	27V51
M40 Smart Wi-Fi Thermostat	3-5/16 x 4-5/16 x 7/8	30L27
Thermostat Accessories		
¹ Discharge Air Temperature Sensor (For E40)		88K38
² Remote Outdoor Air Temperature Sensor (For dual-fuel and Humiditrol®)		X2658

¹ Optional for service diagnostics (E40).

² Remote Outdoor Air Temperature Sensor is used with conventional (non-Lennox® Communicating) outdoor units (sensor is furnished with Lennox® Communicating outdoor units). Allows the thermostat to display outdoor temperature. Required in dual-fuel and Humiditrol® applications.

SPECIFICATIONS				ALL REGIONS			
Size			018	024	030	036	
Nominal Tonnage			1.5	2	2.5	3	
Sound Rating Number		dBA	72	73	72	73	
Connections (Sweat)	Liquid line (OD) - in.		3/8	3/8	3/8	3/8	
	Suction line (OD) - in.		3/4	3/4	3/4	7/8	
Compressor Type			1-Stage Scroll	1-Stage Scroll	1-Stage Scroll	1-Stage Scroll	
Refrigerant (15 ft. Line Set)	¹ R-454B charge furnished		4 lbs. 14 oz.	4 lbs. 14 oz.	5 lbs. 10 oz.	6 lbs. 13 oz.	
Refrigerant (30 ft. Line Set)	¹ R-454B charge furnished		5 lbs. 7 oz.	5 lbs. 7 oz.	6 lbs. 3 oz.	7 lbs. 6 oz.	
Indoor Unit Expansion Valve (TXV)			26Z70	26Z70	26Z70	26Z70	
Outdoor Coil	Net face area - ft. ²	Outer coil	16.33	21.00	16.33	21.00	
		Inner coil	- - -	- - -	15.75	20.25	
	Tube diameter - in.		5/16	5/16	5/16	5/16	
	Rows		1	1	2	2	
	Fins - in.		26	26	22	22	
Outdoor Fan	HP		1/8	1/8	1/8	1/6	
		Diameter - in.	22	22	22	22	
	Blades		2	3	3	3	
	Cfm		2610	2990	2820	3040	
	Rpm		825	825	825	825	
	Watts		160	160	160	190	
Shipping Data - lbs.			185	205	210	235	
ELECTRICAL DATA							
	Line voltage data (Volts-Phase-Hz)		208/230-1-60	208/230-1-60	208/230-1-60	208/230-1-60	
	² Maximum overcurrent protection (MOCP) amps		15	20	25	30	
	³ Minimum circuit ampacity (MCA)		11.2	13.6	16.6	21.8	
Compressor	Rated load amps		8.3	10.3	12.7	16.7	
	Locked rotor amps		45	60.2	75.6	93.5	
Fan Motor	Full load amps		0.74	0.74	0.74	1.0	
	Locked rotor amps		1.65	1.65	1.65	1.9	
OPTIONAL ACCESSORIES - ORDER SEPARATELY							
Compressor Crankcase Heater	Copeland	27V63	•	•	•	•	
	LG	27U16	•	•	•	•	
Compressor Hard Start Kit	Copeland	63W22	•				
	LG	10J42	•	•	•	•	
Compressor Low Ambient Cut-Off Switch		45F08	•	•	•	•	
Compressor Timed-Off Control		47J27	•	•	•	•	
Freezestat	3/8 in.	93G35	•	•	•	•	
Loss of Charge Switch Kit		84M23	•	•	•	•	
⁴ Low Ambient Kit (Fan Cycling)		34M72	•	•	•	•	
Refrigerant Line Sets	3/8 x 3/4 3/8 20 ft.	89J56					
	3/8 x 3/4 3/8 30 ft.	89J57	•	•	•		
	Liquid x Suction OD Insulation Thickness	3/8 x 3/4 3/8 50 ft.	89J59				
	Length	3/8 x 7/8 3/8 30 ft.	89J60				
	3/8 x 7/8 3/8 50 ft.	89J62				•	

NOTE - Extremes of operating range are plus 10% and minus 5% of line voltage.

¹ Refrigerant charge sufficient for the line set length listed in parenthesis. For longer line set requirements see the Installation Instructions or unit Charging Label for information about line set length and additional refrigerant charge required.

² HACR type breaker or fuse.

³ Refer to National or Canadian Electrical Code manual to determine wire, fuse and disconnect size requirements.

⁴ Crankcase Heater and Freezestat are recommended with Low Ambient Kit.

SPECIFICATIONS				ALL REGIONS					
Size				041	042	047	048	060	
Nominal Tonnage				3.5	3.5	4	4	5	
Sound Rating Number dBA				72	72	73	75	74	
Connections (Sweat)				Liquid line (OD) - in.	3/8	3/8	3/8	3/8	3/8
				Suction line (OD) - in.	7/8	7/8	7/8	7/8	1-1/8
Refrigerant (15 ft. Line Set) ¹ R-454B charge furnished				7 lbs. 7 oz.	7 lbs. 2 oz.	7 lbs. 13 oz.	8 lbs. 14 oz.	8 lbs. 14 oz.	
Refrigerant (30 ft. Line Set) ¹ R-454B charge furnished				8 lbs. 0 oz.	7 lbs. 11 oz.	8 lbs. 6 oz.	9 lbs. 7 oz.	9 lbs. 7 oz.	
Indoor Unit Expansion Valve (TXV)				26Z71	26Z71	26Z71	26Z71	26Z72	
Outdoor Coil				Net face area - ft. ² Outer coil	22.17	22.17	22.17	24.93	29.09
				Inner coil	21.33	21.33	21.33	24.13	28.16
				Tube diameter - in.	5/16	5/16	5/16	5/16	5/16
				Rows	2	2	2	2	2
				Fins - in.	22	22	22	22	22
				HP	1/3	1/4	1/3	1/4	1/4
Outdoor Fan				Diameter - in.	26	26	26	22	26
				Blades	3	3	3	4	4
				Cfm	3920	4060	3920	3700	4180
				Rpm	825	825	825	825	825
				Watts	180	260	180	290	290
Shipping Data - lbs.				260	260	260	275	300	
ELECTRICAL DATA									
Line voltage data (Volts-Phase-Hz)				208/230-1-60	208/230-1-60	208/230-1-60	208/230-1-60	208/230-1-60	
² Maximum overcurrent protection (MOCP) amps				30	35	40	45	50	
³ Minimum circuit ampacity (MCA)				21	23.2	25.2	29.7	31.2	
Compressor				Rated load amps	14.7	17.3	18.1	22.4	23.7
				Locked rotor amps	109	123	126	126	157
Fan Motor				Full load amps	2.6	1.56	2.6	1.7	1.56
				Locked rotor amps	---	3.2	---	3.2	3.2
OPTIONAL ACCESSORIES - ORDER SEPARATELY									
Compressor Hard Start Kit				Copeland 10J42	•	•	•	•	•
				LG 10J42		•			
				LG 88M91	•		•	•	•
Compressor Low Ambient Cut-Off Switch				45F08	•	•	•	•	•
Compressor Timed-Off Control				47J27	•	•	•	•	•
Freezestat 3/8 in.				93G35	•	•	•	•	•
Loss of Charge Switch Kit				84M23	•	•	•	•	•
⁴ Low Ambient Kit (Fan Cycling)				34M72	•	•	•	•	•
Refrigerant Line Sets				3/8 x 7/8 3/8 30 ft. 89J60	•	•	•	•	
				3/8 x 7/8 3/8 50 ft. 89J62	•	•	•	•	
Liquid x Suction OD Insulation Thickness Length				3/8 x 1-1/8 3/8 50 ft. 73P91					•

NOTE - Extremes of operating range are plus 10% and minus 5% of line voltage.

¹ Refrigerant charge sufficient for the line set length listed in parenthesis. For longer line set requirements see the Installation Instructions or unit Charging Label for information about line set length and additional refrigerant charge required.

² HACR type breaker or fuse.

³ Refer to National or Canadian Electrical Code manual to determine wire, fuse and disconnect size requirements.

⁴ Crankcase Heater and Freezestat are recommended with Low Ambient Kit.

SOUND DATA

Size	Octave Band Sound Power Levels dBA, re 10 ⁻¹² Watts Center Frequency - HZ							¹ Sound Rating Number (dBA)	² Estimated Sound Pressure Level at Distance From Unit (dBA at distance in ft.)				
	125	250	500	1000	2000	4000	8000		3	5	10	15	50
018	55	60.5	65	67.5	61	55	49	72	65	60	54	51	40
024	56	60.5	67.5	69.5	62	58	51.5	73	65	60	54	51	40
030	56.5	62	68.5	66.5	63.5	58	50.5	72	64	59	53	50	39
036	56	65	68.5	67	64.5	58.5	51.5	73	66	61	55	52	41
041	54.5	61	66.5	65	64	59	52	72	65	60	54	51	40
042	55.5	63	68	68.5	63	56.5	47.5	72	65	60	54	51	40
047	58.5	63	67.5	66	64	59.5	51	73	65	60	54	51	40
048	55.5	63	69	69	66	62	54	75	68	63	57	54	43
060	58	62.5	69	69	65.5	61.5	53.5	74	66	61	55	52	41

NOTE - The octave sound power data does not include tonal correction.

¹ Tested according to AHRI Standard 270-2008 test conditions.

² Estimated sound pressure level at distance based on AHRI Standard 275-2010 method for equipment located on the ground, roof, or on side of building wall with no adjacent reflective surface within 9.8 feet. Sound pressure levels will increase based on changes to assumptions. For other applications, refer to AHRI Standard 275.

FIELD WIRING

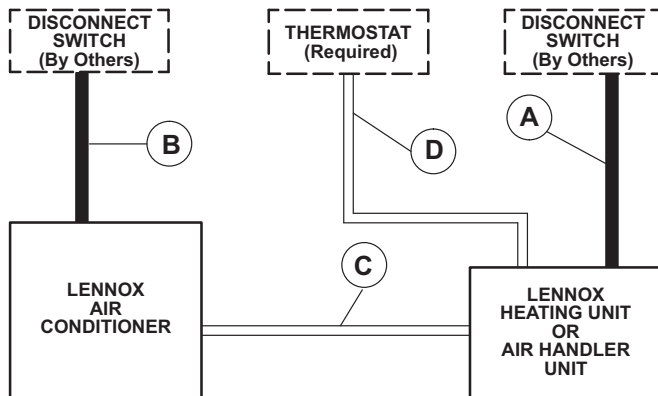

A - Two Wire Power (not furnished)
 B - Two Power (not furnished). See Electrical Data
 C - Four Wire Low Voltage (not furnished). 18 ga. minimum
 D - Five Wire Low Voltage (not furnished). 18 ga. minimum
 All wiring must conform to NEC or CEC and local electrical codes.

INSTALLATION CLEARANCES

NOTES:

- Service Clearance – 30 in. (762 mm) on one of the sides adjacent to the Control Box.
- One of other three sides must be 36 in. (914 mm).
- One of the two remaining sides may be 12 in. (305 mm).
- The remaining side may be 6 in. (152 mm).
- 48 in. (1219 mm) clearance required on top of unit
- 24 in. (610 mm) required between two units

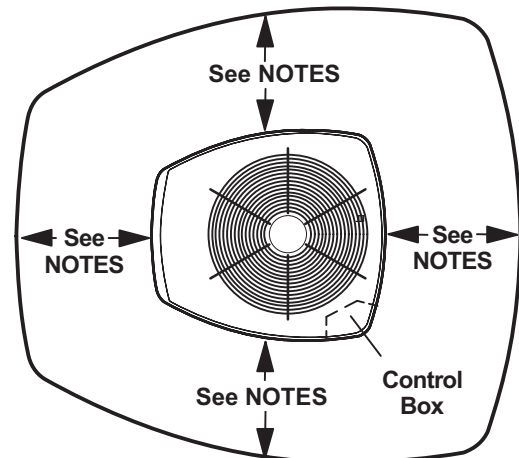

DIMENSIONS - UNIT

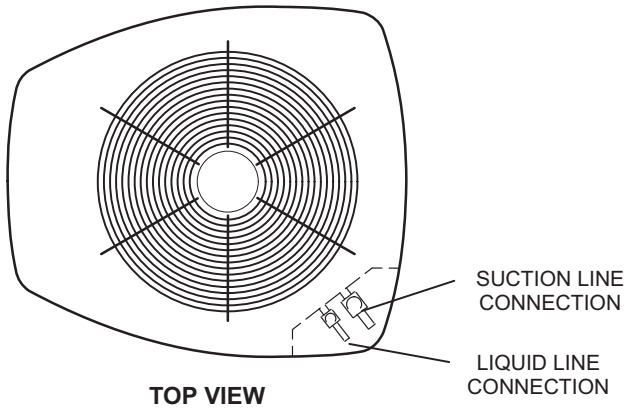

TOP VIEW

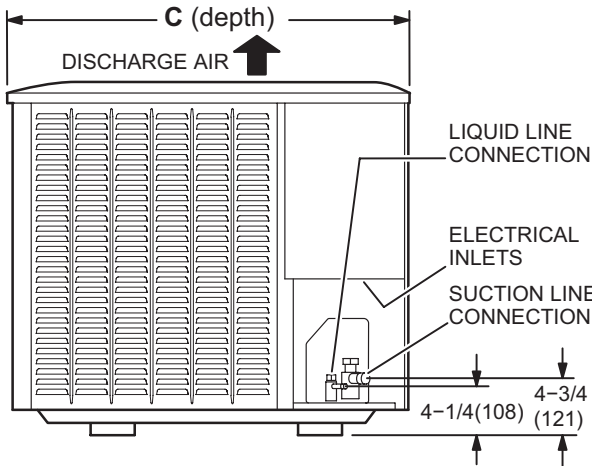

SIDE VIEW

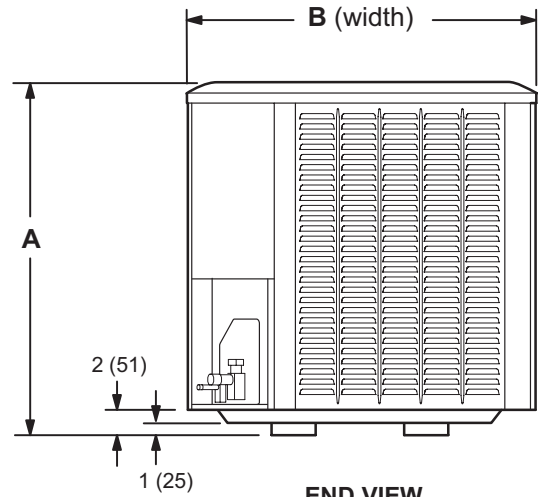

END VIEW

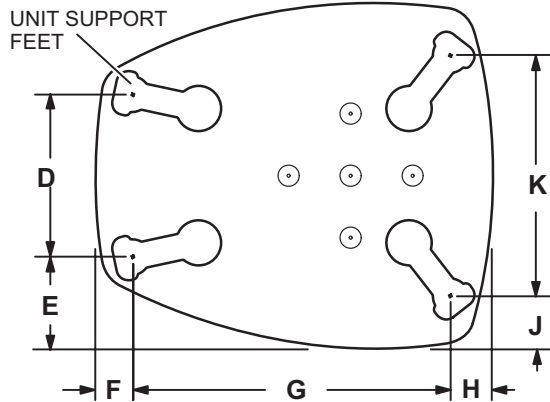

BASE SECTION
(Medium and Large Base)

Size	A (Height)		B (Width)		C (Depth)		D		E		F		G		H		J		K	
	in.	mm	in.	mm	in.	mm	in.	mm	in.	mm	in.	mm	in.	mm	in.	mm	in.	mm	in.	mm
018	31	787	30-1/2	775	35	889	13-7/8	352	7-3/4	197	3-1/4	83	27-1/8	689	3-5/8	92	4-1/2	114	20-5/8	524
024	39	991	30-1/2	775	35	889	13-7/8	352	7-3/4	197	3-1/4	83	27-1/8	689	3-5/8	92	4-1/2	114	20-5/8	524
030	31	787	30-1/2	775	35	889	13-7/8	352	7-3/4	197	3-1/4	83	27-1/8	689	3-5/8	92	4-1/2	114	20-5/8	524
036	39	991	30-1/2	775	35	889	13-7/8	352	7-3/4	197	3-1/4	83	27-1/8	689	3-5/8	92	4-1/2	114	20-5/8	524
041	35	889	35-1/2	902	39-1/2	1003	16-7/8	429	8-3/4	222	3-1/8	79	30-3/4	781	4-5/8	117	3-3/4	95	26-7/8	683
042	35	889	35-1/2	902	39-1/2	1003	16-7/8	429	8-3/4	222	3-1/8	79	30-3/4	781	4-5/8	117	3-3/4	95	26-7/8	683
047	35	889	35-1/2	902	39-1/2	1003	16-7/8	429	8-3/4	222	3-1/8	79	30-3/4	781	4-5/8	117	3-3/4	95	26-7/8	683
048	45	1143	30-1/2	775	35	889	13-7/8	352	7-3/4	197	3-1/4	83	27-1/8	689	3-5/8	92	4-1/2	114	20-5/8	524
060	45	1143	35-1/2	902	39-1/2	1003	16-7/8	429	8-3/4	222	3-1/8	79	30-3/4	781	4-5/8	117	3-3/4	95	26-7/8	683

TXV USAGE

All Lennox coils and air handlers are shipped with a factory installed TXV. In most cases, no substitution is needed.

If a different size TXV is required, it will be listed in the "TXV SUBSTITUTION" table by size. The correct TXV must be ordered separately and field installed.

Size	Order Number
018	26Z70
024	26Z70
030	26Z70
036	26Z70
041	26Z71
042	26Z71
047	26Z71
048	26Z71
060	26Z72

AHRI STANDARD 210/240-2023

Standard Ratings relating to cooling or heating capacities shall be net values, including the effects of circulating-fan heat, but not including supplementary electric heat. Power input used for calculating efficiency shall be the Total Power.

Standard Ratings of units which do not have indoor air-circulating fans furnished as part of the model, i.e., Coil-only System, shall be established by subtracting from the total cooling capacity 1,505 Btu/h per 1,000 SCFM, and by adding the same amount to the heating capacity for non-mobile-home, non-Space Constrained units. Total Power for both heating and cooling shall be increased by 441 W per 1,000 SCFM of indoor air circulated.

TXV SUBSTITUTION - R-454B

A general guide for replacing the factory installed R-454B TXV if the indoor unit (coil/air handler) is larger or smaller than the outdoor unit.

Outdoor Unit		Indoor Unit		Indoor TXV Furnished	Indoor TXV Replacement
Size	Tons	Size	Tons		
018	1.5	42	3.5	26Z71	26Z70
018	1.5	48	4	26Z71	26Z70
018	1.5	49	4	26Z71	26Z70
018	1.5	50/60	4/5	26Z71	26Z70
018	1.5	51/61	4/5	26Z71	26Z70
018	1.5	60	5	26Z72	26Z70
024	2	42	3.5	26Z71	26Z70
024	2	48	4	26Z71	26Z70
024	2	49	4	26Z71	26Z70
024	2	50/60	4/5	26Z71	26Z70
024	2	51/61	4/5	26Z71	26Z70
024	2	60	5	26Z72	26Z70
030	2.5	42	3.5	26Z71	26Z70
030	2.5	48	4	26Z71	26Z70
030	2.5	49	4	26Z71	26Z70
030	2.5	50/60	4/5	26Z71	26Z70
030	2.5	51/61	4/5	26Z71	26Z70
030	2.5	60	5	26Z72	26Z70
036	3	42	3.5	26Z71	26Z70
036	3	48	4	26Z71	26Z70
036	3	49	4	26Z71	26Z70
036	3	50/60	4/5	26Z71	26Z70
036	3	51/61	4/5	26Z71	26Z70
036	3	60	5	26Z72	26Z70
041/042	3.5	24	2	26Z70	26Z71
041/042	3.5	30	2.5	26Z70	26Z71
041/042	3.5	30/36	2.5/3	26Z70	26Z71
041/042	3.5	36	3	26Z70	26Z71
041/042	3.5	60	5	26Z72	26Z71
047/048	4	30/36	2.5/3	26Z70	26Z71
047/048	4	36	3	26Z70	26Z71
047/048	4	60	5	26Z72	26Z71
060	5	50/60	4/5	26Z71	26Z72
060	5	51/61	4/5	26Z71	26Z72

TXV Ranges:

26Z70 - 1.5 to 3 ton systems - Use on 3 ton (036) and lower systems.

26Z71 - 3.5-4 ton systems - Use on 4 ton (048) and down to 3.5 ton (042) systems.

26Z72 - 5 ton systems - Use on 5 ton (060) systems only.

REVISIONS

Sections	Description of Change
Control Options	Updated to reflect latest product offering.



Visit us at www.Lennox.com

For the latest technical information, www.LennoxPros.com

Contact us at 1-800-4-LENNOX

NOTE - Due to Lennox' ongoing commitment to quality, Specifications, Ratings and Dimensions subject to change without notice and without incurring liability. Improper installation, adjustment, alteration, service or maintenance can cause property damage or personal injury. Installation and service must be performed by a qualified installer and servicing agency.

©2026 Lennox Industries, Inc.