

**ML13KC1 (R-454B) SERIES UNITS WITH ALL-ALUMINUM COIL**

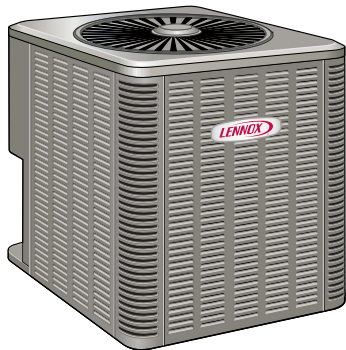

**⚠ WARNING**

Improper installation, adjustment, alteration, service or maintenance can cause property damage, personal injury or loss of life. Installation and service must be performed by a licensed professional HVAC installer or equivalent, service agency, or the gas supplier.

**⚠ CAUTION**

As with any mechanical equipment, contact with sharp sheet metal edges can result in personal injury. Take care while handling this equipment and wear gloves and protective clothing.

**⚠ WARNING**



Electric Shock Hazard. Can cause injury or death. Unit must be properly grounded in accordance with national and local codes.

Line voltage is present at all components when unit is not in operation on units with single-pole contactors. Disconnect all remote electric power supplies before opening access panel. Unit may have multiple power supplies.

**⚠ WARNING**

To prevent serious injury or death:

1. Lock-out/tag-out before performing maintenance.
2. If system power is required (e.g., smoke detector maintenance), disable power to blower, remove fan belt where applicable, and ensure all controllers and thermostats are set to the "OFF" position before performing maintenance.
3. Always keep hands, hair, clothing, jewelry, tools, etc. away from moving parts.

**Table of Contents**

Model Number Identification.....	4
Typical Serial Number Identification .....	4
Unit Dimensions – Inches (mm) .....	8
Typical Unit Parts Arrangement .....	9
Component Specifications .....	10
Refrigerant Metering Device – Indoor Coil .....	10
Operating Gauge Set and Service Valves .....	10
Installation .....	12
Unit Placement .....	12
Removing and Installing Louvered Panels .....	15
New or Replacement Line Set.....	15
Brazing Connections .....	18
Flushing Line Set and Indoor Coil .....	21
Installing Indoor Metering Device .....	22
Leak Testing the System .....	23
Evacuating Line Set and Indoor Coil .....	24
Electrical – Circuit Sizing and Wire Routing .....	25
System Operation.....	29
Maintenance .....	29
Typical Field Wiring .....	31
Servicing Units Delivered Void of Charge .....	32
Unit Start-Up .....	33
System Refrigerant .....	33
Charging .....	34
Start Up Test Procedure .....	34

**⚠ IMPORTANT**

This unit must be matched with an indoor coil as specified with AHRI. For AHRI Certified system match-ups and expanded ratings, visit [www.LennoxPros.com](http://www.LennoxPros.com). Coils previously charged with HCFC-22 must be flushed.

**General Information**

This ML13KC1 outdoor air conditioner **with all-aluminum coil** is designed for use with R-454B refrigerant only. This unit must be installed with an approved indoor air handler or coil. For AHRI Certified system match-ups and expanded ratings, visit [www.LennoxPros.com](http://www.LennoxPros.com). These instructions are intended as a general guide and do not supersede local codes in any way. Consult authorities having jurisdiction before installation.

This outdoor unit is designed for use in systems that use the following refrigerant metering device:

- Thermal expansion valve (TXV)

**IMPORTANT:** Special procedures are required for cleaning the aluminum coil in this unit. See page 28 in this manual for information.

## **WARNING**

- The appliance shall be stored in a room without continuously operating ignition sources (for example: open flames, an operating gas appliance, or an operating electric heater).
- Do not pierce or burn.
- Be aware that refrigerants may not contain an odor.

## **CAUTION**

Servicing shall be performed only as recommended by the manufacturer.

## **WARNING**

Ducts connected to an appliance shall not contain a potential ignition source

## **WARNING**

Every working procedure that affects safety means shall only be carried out by competent persons. This appliance is not to be used by persons (including children) with reduced physical, sensory or mental capabilities, or lack of experience and knowledge, unless they have been given supervision or instruction concerning use of the appliance by a person responsible for their safety. Children should be supervised to ensure they do not play with the appliance.

## **IMPORTANT**

Ensure that the area is in the open or that it is adequately ventilated before breaking into the system or conducting any hot work. A degree of ventilation shall continue during the period that the work is carried out.

## **IMPORTANT**

Verify cabling will not be subject to wear, corrosion, excessive pressure, vibration, sharp edges or any other adverse environmental effects.

## **IMPORTANT**

Pipe work, including piping material, pipe routing, and installation shall include protection from physical damage in operation and service, and be in compliance with national and local codes and standards, such as ASHRAE 15, ASHRAE 15.2, UL 207, IAPMO Uniform Mechanical Code, ICC International Mechanical Code, or CSA B52. All field joints shall be accessible for inspection prior to being covered or enclosed.

## **CAUTION**

Under no circumstances shall potential sources of ignition be used in the searching for or detection of refrigerant leaks. A halide torch (or any other detector using a naked flame) shall not be used.

The following leak detection methods are deemed acceptable for all refrigerant systems.

Electronic leak detectors may be used to detect refrigerant leaks but, in the case of flammable refrigerants, the sensitivity may not be adequate, or may need recalibration. (Detection equipment shall be calibrated in a refrigerant-free area.) Ensure that the detector is not a potential source of ignition and is suitable for the refrigerant used. Leak detection equipment shall be set at a percentage of the LFL of the refrigerant and shall be calibrated to the refrigerant employed, and the appropriate percentage of gas (25 % maximum) is confirmed. Leak detection fluids are also suitable for use with most refrigerants but the use of detergents containing chlorine shall be avoided as the chlorine may react with the refrigerant and corrode the copper pipe-work. If a leak is suspected, all naked flames shall be removed/extinguished. If a leakage of refrigerant is found which requires brazing, all of the refrigerant shall be recovered from the system, or isolated (by means of shut off valves) in a part of the system remote from the leak.

## **CAUTION**

Some soaps used for leak detection are corrosive to certain metals. Carefully rinse piping thoroughly after leak test has been completed. Do not use matches, candles, flame or other sources of ignition to check for gas leaks.

## **WARNING**

PARTIAL UNITS shall only be connected to an appliance suitable for the same refrigerant.

## **⚠ IMPORTANT**

When breaking into the refrigerant circuit to make repairs – or for any other purpose – conventional procedures shall be used. However, for flammable refrigerants it is important that best practice be followed and, since flammability is a consideration, procedures such as safely remove refrigerant following local and national regulations, purging the circuit with inert gas, evacuating (optional for A2L), purging with inert gas (optional for A2L), or opening the circuit by cutting or brazing be adhered to. The refrigerant charge shall be recovered into the correct recovery cylinders if venting is not allowed by local and national codes. For appliances containing flammable refrigerants, the system shall be purged with oxygen-free nitrogen to render the appliance safe for flammable refrigerants.

This process might need to be repeated several times. Compressed air or oxygen shall not be used for purging refrigerant systems. For appliances containing flammable refrigerants, refrigerants purging shall be achieved by breaking the vacuum in the system with oxygen-free nitrogen and continuing to fill until the working pressure is achieved, then venting to atmosphere, and finally pulling down to a vacuum (optional for A2L). This process shall be repeated until no refrigerant is within the system (optional for A2L). When the final oxygen-free nitrogen charge is used, the system shall be vented down to atmospheric pressure to enable work to take place. Ensure that the outlet for the vacuum pump is not close to any potential ignition sources and that ventilation is available.

## **⚠ IMPORTANT**

In addition to conventional charging procedures, the following requirements shall be followed.

- Ensure that contamination of different refrigerants does not occur when using charging equipment. Hoses or lines shall be as short as possible to minimize the amount of refrigerant contained in them.
- Cylinders shall be kept in an appropriate position according to the instructions.
- Ensure that the REFRIGERATING SYSTEM is earthed prior to charging the system with refrigerant.
- Label the system when charging is complete (if not already).
- Extreme care shall be taken not to overfill the REFRIGERATING SYSTEM.

Prior to recharging the system, it shall be pressure-tested with the appropriate purging gas. The system shall be leak tested on completion of charging, but prior to commissioning. A follow up leak test shall be carried out prior to leaving the site.

## **⚠ IMPORTANT**

When removing refrigerant from a system, either for servicing or decommissioning, it is recommended good practice that all refrigerants are removed safely.

When transferring refrigerant into cylinders, ensure that only appropriate refrigerant recovery cylinders are employed. Ensure that the correct number of cylinders for holding the total system charge is available. All cylinders to be used are designated for the recovered refrigerant and labelled for that refrigerant (i. e. special cylinders for the recovery of refrigerant). Cylinders shall be complete with pressure-relief valve and associated shut-off valves in good working order. Empty recovery cylinders are evacuated and, if possible, cooled before recovery occurs.

The recovery equipment shall be in good working order with a set of instructions concerning the equipment that is at hand and shall be suitable for the recovery of all appropriate refrigerants including, when applicable, flammable refrigerants. In addition, a set of calibrated weighing scales shall be available and in good working order. Hoses shall be complete with leak-free disconnect couplings and in good condition. Before using the recovery machine, check that it is in satisfactory working order, has been properly maintained and that any associated electrical components are sealed to prevent ignition in the event of a refrigerant release. Consult manufacturer if in doubt.

The recovered refrigerant shall be returned to the refrigerant supplier in the correct recovery cylinder, and the relevant waste transfer note arranged. Do not mix refrigerants in recovery units and especially not in cylinders.

If compressors or compressor oils are to be removed, ensure that they have been evacuated to an acceptable level to make certain that flammable refrigerant does not remain within the lubricant. The evacuation process shall be carried out prior to returning the compressor to the suppliers. Only electric heating to the compressor body shall be employed to accelerate this process. When oil is drained from a system, it shall be carried out safely.

## **⚠ IMPORTANT**

After completion of field piping for split systems, the field pipework shall be pressure tested with an inert gas and then vacuum tested prior to refrigerant charging, according to the following requirements;

– Field-made refrigerant joints indoors shall be tightness tested. The test method shall have a sensitivity of .2 oz. per year of refrigerant or better, under pressure.

No leak shall be detected.

## Model Number Identification

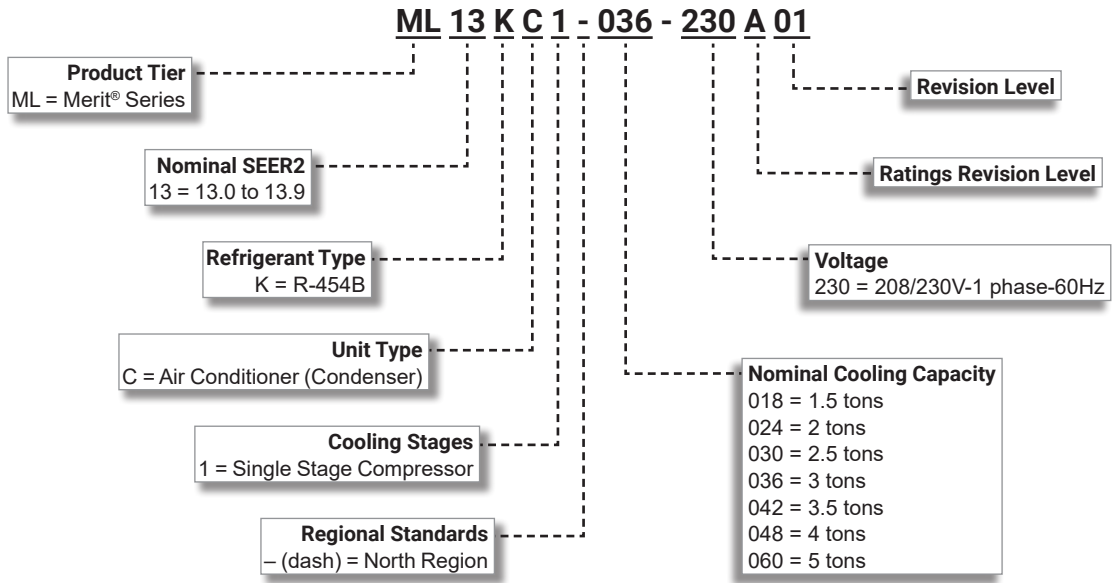

## Typical Serial Number Identification

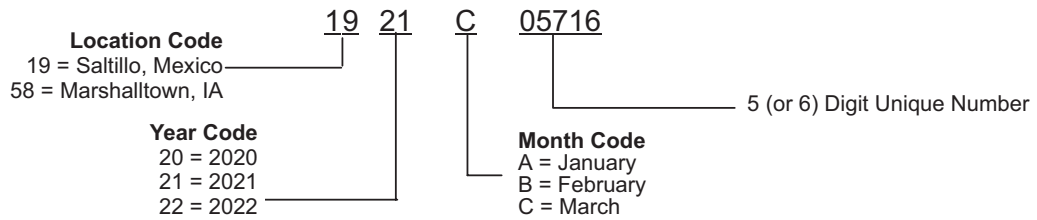

**NOTE** – R-454b is a A2L refrigerant. The system installation must meet the following parameters based upon total refrigerant charge (line set included). T<sub>Amin</sub> (Total minimum conditioned area) is the minimum allowable conditioned area based upon the total system charge at sea level. Values must be multiplied by altitude adjustment factor at installed altitude.

Q<sub>min</sub> table refers to minimum airflow requirements during refrigerant leak mitigation by the refrigerant detection system, based upon total system charge.

See tables below.

**T<sub>Amin</sub> Table**

Charge (lb)	10.0	15.0	20.0	25.0	30.0
Charge (kg)	4.5	6.8	9.1	11.3	13.6
Minimum Conditioned Area (ft <sup>2</sup> )	149.9	224.9	299.9	374.8	449.8
Minimum Conditioned Area (m <sup>2</sup> )	13.9	20.9	27.9	34.8	41.8

**NOTE** – Multiply values in T<sub>Amin</sub> table by the Altitude Adjustment Factors to correct T<sub>Amin</sub> based on installed altitude.

**Altitude Adjustment Factor**

<b>Altitude (m)</b>	0	200	400	600	800	1000	1200	1400	1600
<b>Altitude (ft)</b>	0	660	1310	1970	2620	3280	3940	4590	5250
<b>Adj. Factor</b>	1	1	1	1	1.02	1.05	1.04	1.1	1.12
<b>Altitude (m)</b>	1600	1800	2000	2200	2400	2600	2800	3000	3200
<b>Altitude (ft)</b>	5250	5910	6560	7220	7870	8530	9190	9840	10500
<b>Adj. Factor</b>	1.12	1.15	1.18	1.21	1.25	1.28	1.32	1.36	1.4

**Q<sub>min</sub> Table**

<b>Refrigerant Charge lb (kg)</b>	<b>CFM Required</b>	<b>Refrigerant Charge lb (kg)</b>	<b>CFM Required</b>
5 (2.3)	135	18 (8.1)	487
6 (2.7)	162	19 (8.6)	514
7 (3.2)	189	20 (9.1)	541
8 (3.6)	216	21 (9.5)	568
9 (4.1)	244	22 (10)	595
10 (4.5)	271	23 (10.4)	622
11 (5)	298	24 (10.9)	649
12 (5.4)	325	25 (11.3)	676
13 (5.9)	352	26 (11.7)	704
14 (6.4)	379	27 (12.2)	731
15 (6.8)	406	28 (12.7)	758
16 (7.3)	433	29 (13.2)	785
17 (7.7)	460	30 (13.6)	812

**NOTE** – Q<sub>min</sub> minimum airflow requirement for refrigerant leak mitigation.

SPECIFICATIONS			NORTH REGION			
Size			018	024	030	036
Nominal Tonnage			1.5	2	2.5	3
Sound Rating Number		dBA	73	76	76	76
Connections (Sweat)	Liquid line (OD) - in.		3/8	3/8	3/8	3/8
	Suction line (OD) - in.		3/4	3/4	3/4	7/8
Compressor Type			1-Stage Scroll	1-Stage Scroll	1-Stage Scroll	1-Stage Scroll
Refrigerant (15 ft. Line Set)	<sup>1</sup> R-454B charge furnished		4 lbs. 0 oz.	4 lbs. 7 oz.	4 lbs. 14 oz.	5 lbs. 10 oz.
Refrigerant (30 ft. Line Set)	<sup>1</sup> R-454B charge furnished		4 lbs. 9 oz.	5 lbs. 0 oz.	5 lbs. 7 oz.	6 lbs. 3 oz.
Indoor Unit Expansion Valve (TXV)			<b>26Z70</b>	<b>26Z70</b>	<b>26Z70</b>	<b>26Z70</b>
Outdoor Coil	Net face area - ft. <sup>2</sup>		11.33	13.22	16.33	18.67
	Tube diameter - in.		5/16	5/16	5/16	5/16
	Rows		1	1	1	1
	Fins - in.		26	26	26	26
Outdoor Fan	HP		1/10	1/10	1/6	1/6
	Diameter - in.		18	18	22	22
	Blades		3	3	3	3
	Cfm		2290	2350	2610	2800
	Rpm		1075	1075	825	825
	Watts		150	155	160	190
Shipping Data - lbs.			128	134	152	161
ELECTRICAL DATA						
	Line voltage data (Volts-Phase-Hz)		208/230-1-60	208/230-1-60	208/230-1-60	208/230-1-60
	<sup>2</sup> Maximum overcurrent protection (MOCP) amps		15	20	25	30
	<sup>3</sup> Minimum circuit ampacity (MCA)		11.1	13.5	16.6	17.8
Compressor	Rated load amps		8.3	10.2	12.5	13.4
	Locked rotor amps		45	60.2	67.8	82.5
Fan Motor	Full load amps		0.65	0.65	1.0	1.0
	Locked rotor amps		1.3	1.3	1.9	1.9
OPTIONAL ACCESSORIES - ORDER SEPARATELY						
Compressor	Copeland	<b>27V63</b>	•	•	•	•
Crankcase Heater	LG	<b>27U16</b>	•	•	•	•
Compressor Hard Start Kit	Copeland	<b>63W22</b>	•			
		<b>10J42</b>		•	•	•
	LG	<b>10J42</b>	•	•	•	•
Compressor Low Ambient Cut-Off Switch		<b>45F08</b>	•	•	•	•
Compressor Timed-Off Control		<b>47J27</b>	•	•	•	•
Compressor Sound Cover		<b>18J42</b>	•	•	•	•
Freezestat	3/8 in.	<b>93G35</b>	•	•	•	•
Loss of Charge Switch Kit		<b>84M23</b>	•	•	•	•
<sup>4</sup> Low Ambient Kit (Fan Cycling)		<b>34M72</b>	•	•	•	•
Refrigerant Line Sets	3/8 x 3/4   3/8   20 ft.	<b>89J56</b>				
	3/8 x 3/4   3/8   30 ft.	<b>89J57</b>	•	•	•	
Liquid x Suction OD   Insulation Thickness   Length	3/8 x 3/4   3/8   50 ft.	<b>89J59</b>				
	3/8 x 7/8   3/8   30 ft.	<b>89J60</b>				
	3/8 x 7/8   3/8   50 ft.	<b>89J62</b>				•
Unit Stand-Off Kit		<b>94J45</b>	•	•	•	•

NOTE - Extremes of operating range are plus 10% and minus 5% of line voltage.

<sup>1</sup> Refrigerant charge sufficient for the line set length listed in parenthesis. For longer line set requirements see the Installation Instructions or unit Charging Label for information about line set length and additional refrigerant charge required.

<sup>2</sup> HACR type breaker or fuse.

<sup>3</sup> Refer to National or Canadian Electrical Code manual to determine wire, fuse and disconnect size requirements.

<sup>4</sup> Crankcase Heater and Freezestat are recommended with Low Ambient Kit.

SPECIFICATIONS			NORTH REGION		
<b>Size</b>			<b>042</b>	<b>048</b>	<b>060</b>
<b>Nominal Tonnage</b>			3.5	4	5
<b>Sound Rating Number</b>	dBA		76	78	80
<b>Connections (Sweat)</b>	Liquid line (OD) - in.		3/8	3/8	3/8
	Suction line (OD) - in.		7/8	7/8	1-1/8
<b>Compressor Type</b>			1-Stage Scroll	1-Stage Scroll	1-Stage Scroll
<b>Refrigerant (15 ft. Line Set)</b>	<sup>1</sup> R-454B charge furnished		6 lbs. 2 oz.	7 lbs. 10 oz.	8 lbs. 8 oz.
<b>Refrigerant (30 ft. Line Set)</b>	<sup>1</sup> R-454B charge furnished		6 lbs. 11 oz.	8 lbs. 3 oz.	9 lbs. 1 oz.
<b>Indoor Unit Expansion Valve (TXV)</b>			<b>26Z71</b>	<b>26Z71</b>	<b>26Z72</b>
<b>Outdoor Coil</b>	Net face area - ft. <sup>2</sup>	Outer coil	21.00	16.33	21.00
		Inner coil	---	16.33	20.25
	Tube diameter - in.	5/16	5/16	5/16	
	Rows	1	2	2	
	Fins - in.	26	22	22	
<b>Outdoor Fan</b>	HP	1/3	1/4	1/6	
	Diameter - in.	22	22	22	
	Blades	3	3	4	
	Cfm	2985	2875	3250	
	Rpm	825	825	845	
	Watts	150	160	280	
<b>Shipping Data - lbs.</b>			195	215	218
<b>ELECTRICAL DATA</b>					
Line voltage data (Volts-Phase-Hz)			208/230-1-60	208/230-1-60	208/230-1-60
<sup>2</sup> Maximum overcurrent protection (MOCP) amps			35	40	50
<sup>3</sup> Minimum circuit ampacity (MCA)			21.2	24.3	31.3
<b>Compressor</b>	Rated load amps		14.9	18.0	23.7
	Locked rotor amps		109	126	157
<b>Fan Motor</b>	Full load amps		2.6	1.7	1.7
	Locked rotor amps		---	3.2	3.2
<b>OPTIONAL ACCESSORIES - ORDER SEPARATELY</b>					
<b>Compressor</b>	Copeland	<b>27P59</b>	•	Factory	Factory
<b>Crankcase Heater</b>	LG	<b>27U16</b>	•	Factory	Factory
<b>Compressor Hard Start Kit</b>	Copeland	<b>10J42</b>	•	•	•
	LG	<b>88M91</b>	•	•	•
<b>Compressor Low Ambient Cut-Off Switch</b>		<b>45F08</b>	•	•	•
<b>Compressor Sound Cover</b>		<b>18J42</b>	•	•	•
<b>Compressor Timed-Off Control</b>		<b>47J27</b>	•	•	•
<b>Freezestat</b>	3/8 in.	<b>93G35</b>	•	•	•
<b>Loss of Charge Switch Kit</b>		<b>84M23</b>	•	•	•
<sup>4</sup> <b>Low Ambient Kit (Fan Cycling)</b>		<b>34M72</b>	•	•	•
<b>Refrigerant Line Sets</b>	3/8 x 7/8   3/8   30 ft.	<b>89J60</b>	•	•	
	3/8 x 7/8   3/8   50 ft.	<b>89J62</b>	•	•	
Liquid x Suction OD   Insulation Thickness   Length	3/8 x 1-1/8   3/8   50 ft.	<b>73P91</b>			•
<b>Unit Stand-Off Kit</b>		<b>94J45</b>	•	•	•

NOTE - Extremes of operating range are plus 10% and minus 5% of line voltage.

<sup>5</sup> Refrigerant charge sufficient for the line set length listed in parenthesis. For longer line set requirements see the Installation Instructions or unit Charging Label for information about line set length and additional refrigerant charge required.

<sup>6</sup> HACR type breaker or fuse.

<sup>7</sup> Refer to National or Canadian Electrical Code manual to determine wire, fuse and disconnect size requirements.

<sup>8</sup> Crankcase Heater and Freezestat are recommended with Low Ambient Kit.

# Unit Dimensions – Inches (mm)

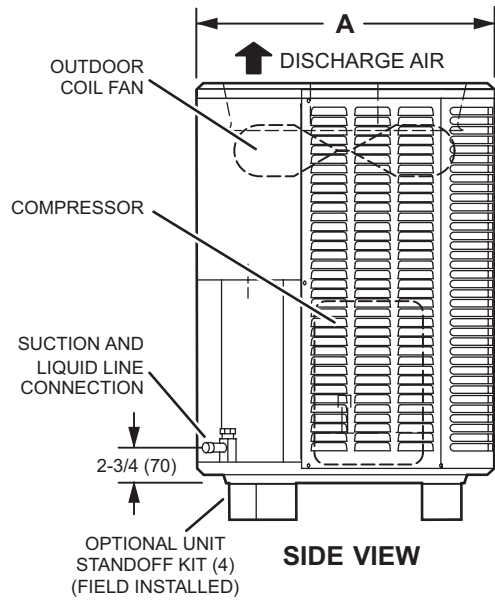
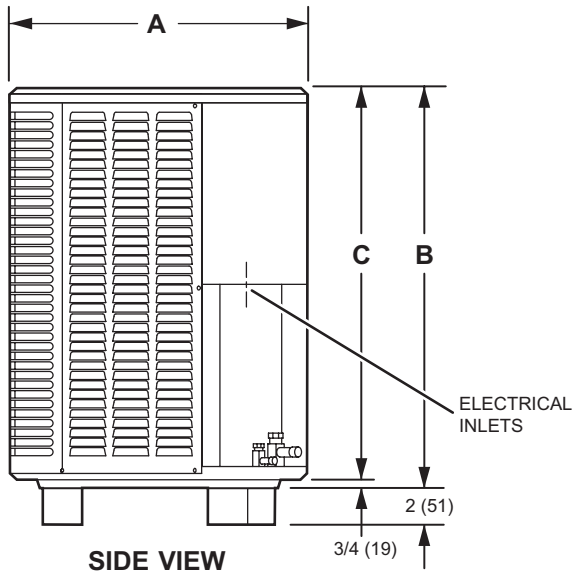
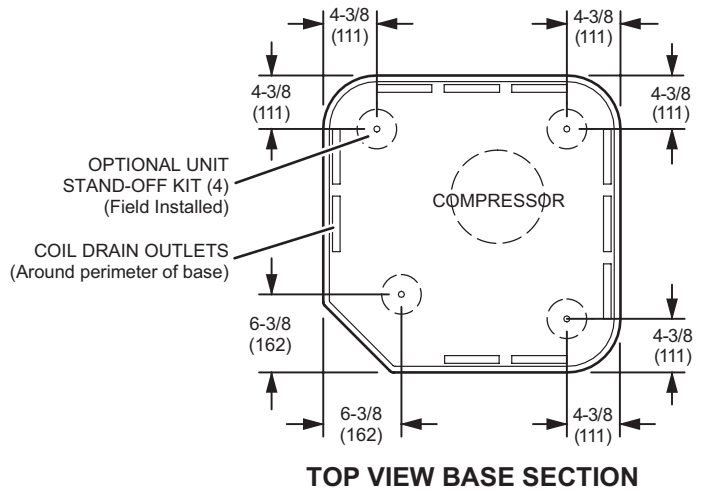
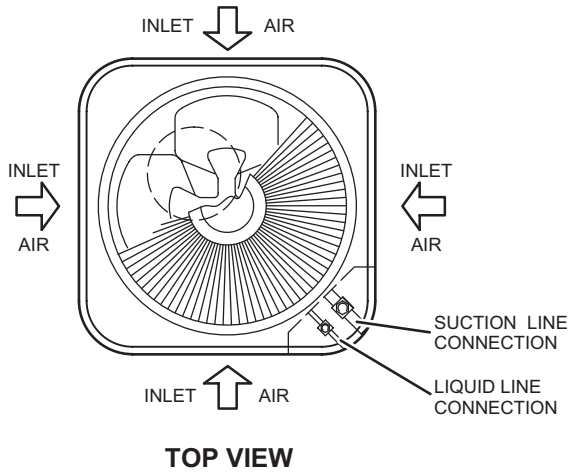

Size	A Width and Depth		B Height		C	
	inches	mm	inches	mm	inches	mm
018	24-1/4	616	25-1/4	641	24-1/2	622
024	24-1/4	616	29-1/4	743	28-1/2	724
030	28-1/4	718	29-1/4	743	28-1/2	724
036	28-1/4	718	33-1/4	845	32-1/2	826
042	28-1/4	718	37-1/4	946	36-1/2	927
048	28-1/4	718	29-1/4	743	28-1/2	724
060	28-1/4	718	37-1/4	946	36-1/2	927

# Typical Unit Parts Arrangement

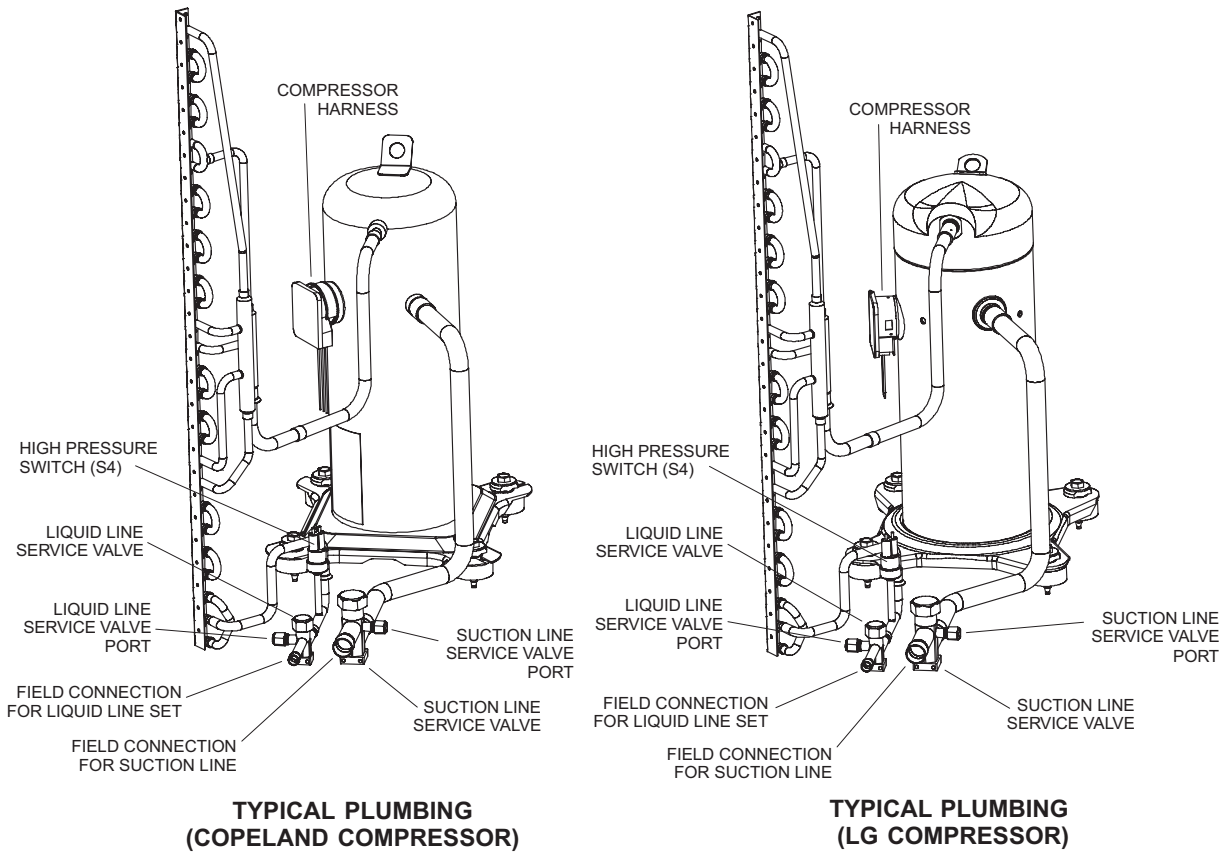
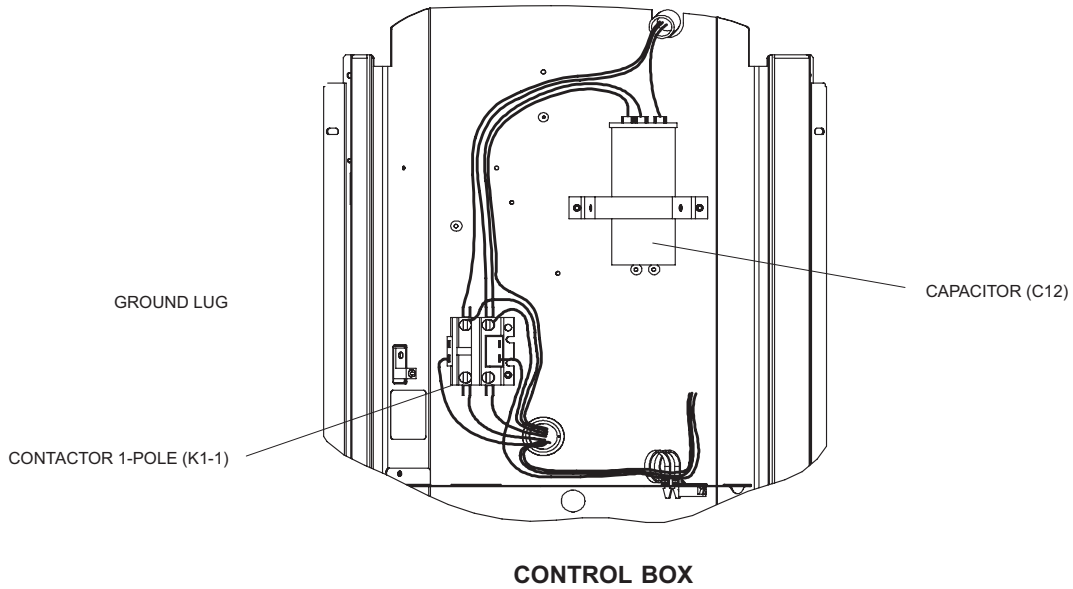

**FIGURE 1.**

## Component Specifications

**TABLE 1. REFRIGERANT LINE SETS - INCHES (MM)**

Model	Valve Size Connections		Recommended Line Sets	
	Liquid Line	Suction Line	Liquid x Suction OD   Insulation Thickness   Length	Order Number
-018 -024 -030	3/8" (10 mm)	3/4" (19 mm)	3/8 x 3/4   3/8   20 ft. (6 m)	89J56
3/8 x 3/4   3/8   30 ft. (9 m)			89J57	
3/8 x 3/4   3/8   50 ft. (15.2 m)			89J59	
-036 -042 -048	3/8" (10 mm)	7/8" (22 mm)	3/8 x 7/8   3/8   30 ft. (9 m)	89J60
3/8 x 7/8   3/8   50 ft. (15.2 m)			89J62	
-060	3/8" (10 mm)	1-1/8" (29 mm) *	3/8 x 1-1/8   3/8   50 ft. (15.2 m)	73P91

\* Some applications may require a field-provided 1-1/8" to 7/8" adapter.

### Refrigerant Metering Device – Indoor Coil

#### EXPANSION VALVE (TXV) METERING

This unit is also compatible with systems that use an expansion valve. Refer to any of the publications listed below to obtain the required catalog number for a specific expansion valve.

- Lennox ML13KC1 Product Specification (EHB)
- Lennox Product Catalog

### Operating Gauge Set and Service Valves

#### TORQUE REQUIREMENTS

When servicing or repairing heating, ventilating, and air conditioning components, ensure the fasteners are appropriately tightened. Table 2 lists torque values for fasteners.

### IMPORTANT

The Clean Air Act of 1990 bans the intentional venting of refrigerant (CFCs, HCFCs and HFCs) as of July 1, 1992. Approved methods of recovery, recycling or reclaiming must be followed. Fines and/or incarceration may be levied for noncompliance.

### IMPORTANT

Only use Allen wrenches of sufficient hardness (50Rc - Rockwell Harness Scale minimum). Fully insert the wrench into the valve stem recess.

Service valve stems are factory-torqued (from 9 ft-lbs for small valves, to 25 ft-lbs for large valves) to prevent refrigerant loss during shipping and handling. Using an Allen wrench rated at less than 50Rc risks rounding or breaking off the wrench, or stripping the valve stem recess.

See the Lennox Service and Application Notes #C-08-1 for further details and information.

### IMPORTANT

To prevent stripping of the various caps used, the appropriately sized wrench should be used and fitted snugly over the cap before tightening.

**TABLE 2. Torque Requirements**

Parts	Recommended Torque	
Service valve cap	8 ft.- lb.	11 NM
Sheet metal screws	16 ft.- lb.	2 NM
Machine screws #10	28 ft.- lb.	3 NM
Compressor bolts	90 in.- lb.	10 NM
Gauge port seal cap	8 ft.- lb.	11 NM

#### USING MANIFOLD GAUGE SET

When checking the system charge, only use a manifold gauge set that features low loss anti-blow back fittings.

Manifold gauge set used with R-454B refrigerant systems must be capable of handling the higher system operating pressures. The gauges should be rated for use with pressures of 0 - 800 psig on the high side and a low side of 30" vacuum to 250 psig with dampened speed to 500 psi. Gauge hoses must be rated for use at up to 800 psig of pressure with a 4000 psig burst rating.

#### OPERATING SERVICE VALVES

The liquid and vapor line service valves are used for removing refrigerant, flushing, leak testing, evacuating, checking charge and charging. Each valve is equipped with a service port which has a factory-installed valve stem. Figure 2 provides information on access and operation of both angle and ball service valves

# SERVICE VALVES ANGLE AND BALL

## Operating Angle Type Service Valve:

1. Remove stem cap with an appropriately sized wrench.
2. Use a service wrench with a hex-head extension (3/16" for liquid line valve sizes and 5/16" for vapor line valve sizes) to back the stem out counterclockwise as far as it will go.

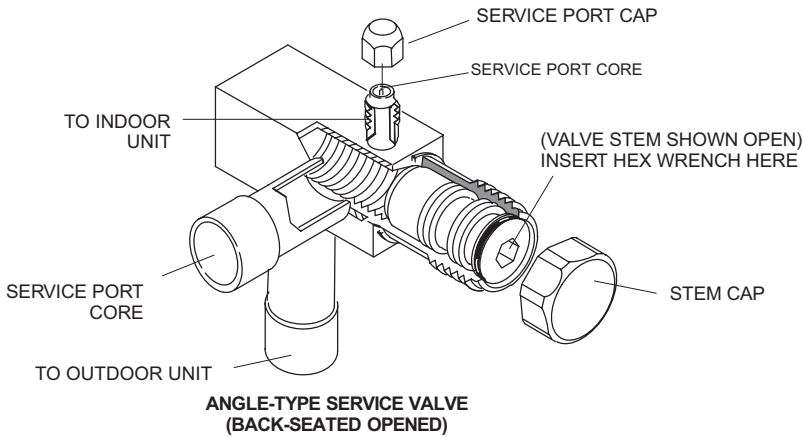

When service valve is **OPEN**, the service port is open to line set, indoor and outdoor unit.

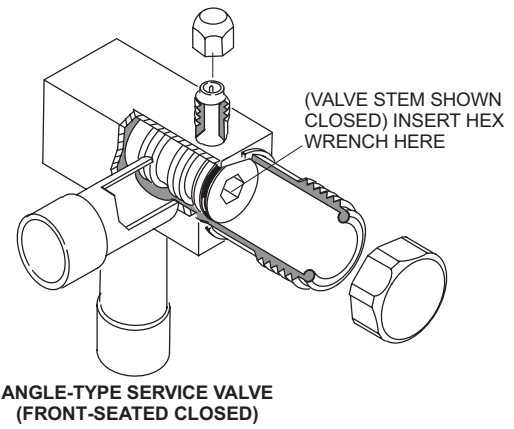

WHEN SERVICE VALVE IS **CLOSED**, THE SERVICE PORT IS OPEN TO THE LINE SET AND INDOOR UNIT.

## Operating Ball Type Service Valve:

1. Remove stem cap with an appropriately sized wrench.
2. Use an appropriately sized wrench to open. To open valve, rotate stem counterclockwise 90°. To close rotate stem clockwise 90°.

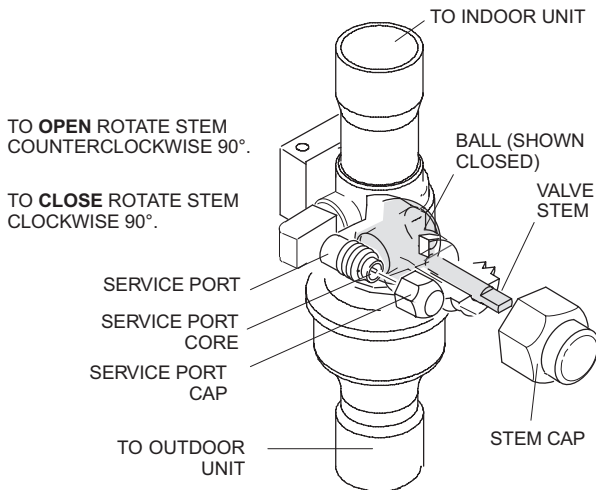

## To Access Service Port:

A service port cap protects the service port core from contamination and serves as the primary leak seal.

1. Remove service port cap with an appropriately sized wrench.
2. Connect gauge set to service port.
3. When testing is completed, replace service port cap and tighten as follows:
  - With torque wrench: Finger tighten and torque cap per table 3.
  - Without torque wrench: Finger tighten and use an appropriately sized wrench to turn an additional 1/6 turn clockwise.

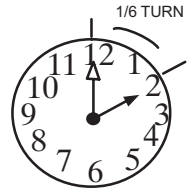

## Reinstall Stem Cap:

Stem cap protects the valve stem from damage and serves as the primary seal. Replace the stem cap and tighten as follows:

- With Torque Wrench: Finger tighten and then torque cap per table 3.
- Without Torque Wrench: Finger tighten and use an appropriately sized wrench to turn an additional 1/12 turn clockwise.

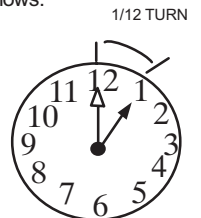

NOTE — A label with specific torque requirements may be affixed to the stem cap. If the label is present, use the specified torque.

**FIGURE 2. Angle and Ball Service Valves**

## Installation

### Unit Placement

See Unit Dimensions on page 8 for sizing mounting slab, platforms or supports.

### CAUTION

In order to avoid injury, take proper precaution when lifting heavy objects..

### POSITIONING CONSIDERATIONS

Consider the following when positioning the unit:

- Some localities are adopting sound ordinances based on the unit's sound level registered from the adjacent property, not from the installation property. Install the unit as far as possible from the property line.
- When possible, do not install the unit directly outside a window. Glass has a very high level of sound transmission. For proper placement of unit in relation to a window see the provided illustration in figure 4, detail A.

### PLACING UNIT ON SLAB

When installing unit at grade level, the top of the slab should be high enough above grade so that water from higher ground will not collect around the unit.

The slab should have a slope tolerance as described in figure 4, detail B.

**NOTE** – *If necessary for stability, anchor unit to slab as described in figure 4, detail B.*

### ROOF MOUNTING

Install the unit a minimum of 6 inches (152 mm) above the roof surface to avoid ice build-up around the unit. Locate the unit above a load bearing wall or area of the roof that can adequately support the unit. Consult local codes for rooftop applications. If unit coil cannot be mounted away from prevailing winter winds, a wind barrier should be constructed. Size barrier at least the same height and width as outdoor unit. Mount barrier 24 inches (610 mm) from the sides of the unit in the direction of prevailing winds.

### NOTICE

#### Roof Damage!

This system contains both refrigerant and oil. Some rubber roofing material may absorb oil, causing the rubber to swell. Bubbles in the rubber roofing material can cause leaks. Protect the roof surface to avoid exposure to refrigerant and oil during service and installation. Failure to follow this notice could result in damage to roof surface.

### SINGLE-UNIT INSTALLATION

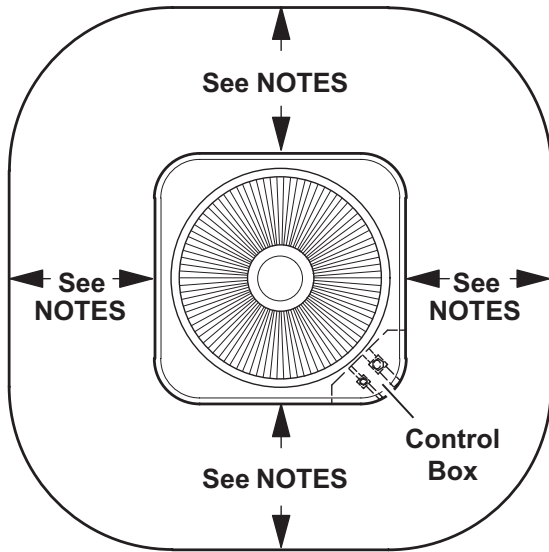

#### Single-Unit Installation Notes:

- Service Clearance - 24 in. (610 mm) on one of the sides adjacent to the Control Box.
- One of other three sides must be 36 in. (914 mm).
- One of the two remaining sides may be 12 in. (305 mm).
- The remaining side may be 6 in. (152 mm).
- 48 in. (1219 mm) clearance required on top of unit.

### MULTI-UNIT INSTALLATIONS

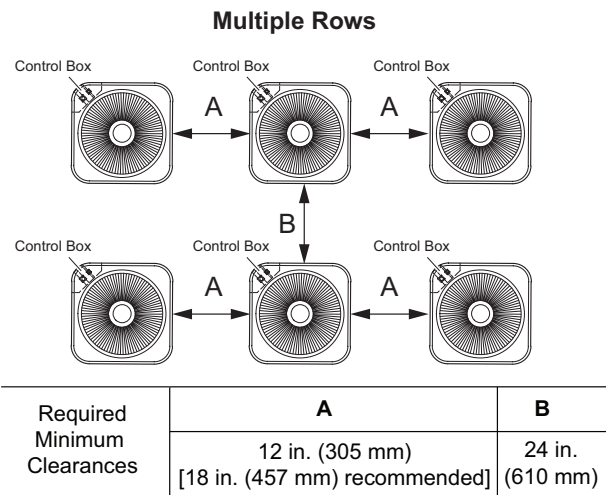
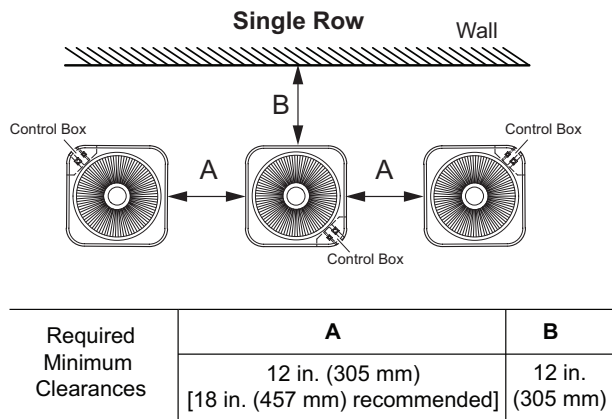

#### Multi-Unit Installation Notes:

- Recommended service clearance of 24 in. (610 mm) on one side.
- 48 in. (1219 mm) clearance required on top of the unit.

**FIGURE 3. Installation Clearances**

## DETAIL A

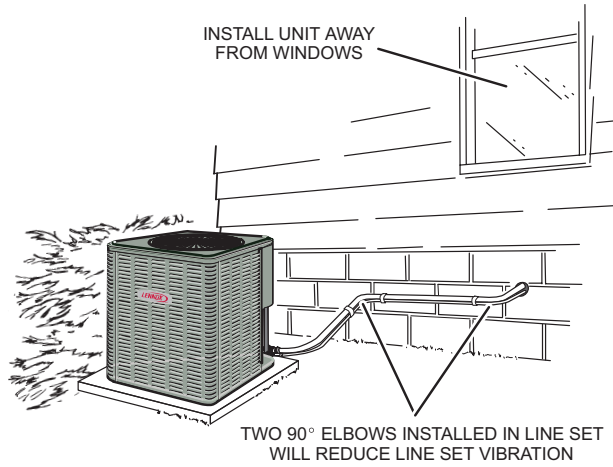

## DETAIL B

Install unit level or, if on a slope, maintain slope tolerance of 2 degrees (or 2 inches per 5 feet [50 mm per 1.5 m]) away from building structure.

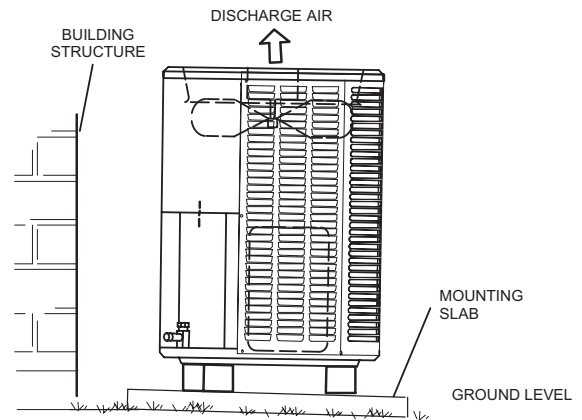

**FIGURE 4. Placement and Slab Mounting**

## Removing and Installing Louvered Panels

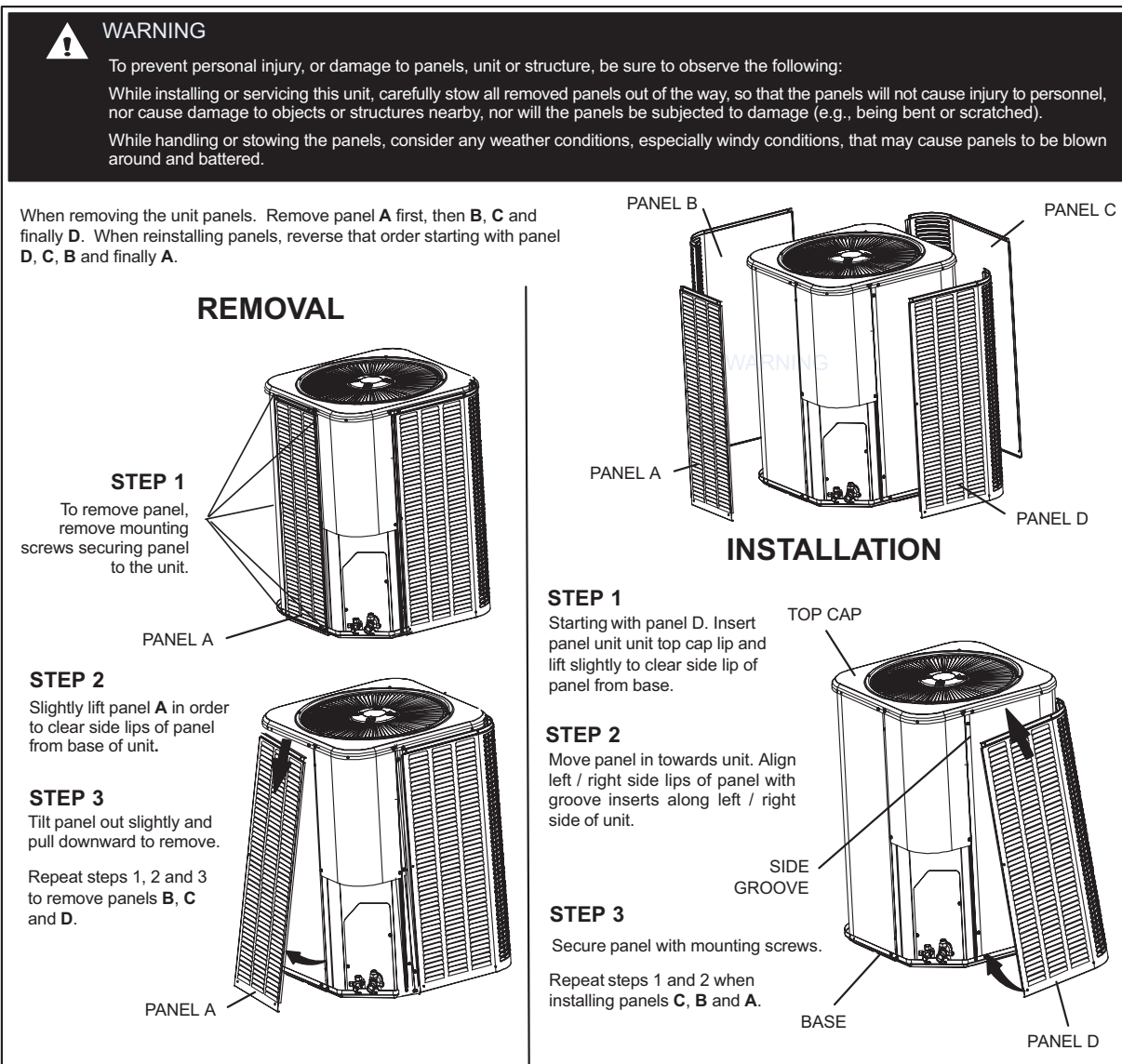

FIGURE 5. Removing and Installing Panels

TABLE 3

REFRIGERANT LINE SET – INCHES (MM)					
Model	Valve Field Connections		Recommended Line Set		
	Liquid Line	Vapor Line	Liquid Line	Vapor Line	L15 Line Sets
-018	3/8 in. (10 mm)	3/4 in. (19 mm)	3/8 in. (10 mm)	3/4 in. (19 mm)	L15-41 15 ft. - 50 ft. (4.6 m - 15 m)
-024					
-030					
-036	3/8 in. (10 mm)	7/8 in. (22 mm)	3/8 in. (10 mm)	7/8 in. (22 mm)	L15-65 15 ft. - 50 ft. (4.6 m - 15 m)
-042					
-048					
-060	3/8 in. (10 mm)	1-1/8 in. (28 mm)	3/8 in. (10 mm)	1-1/8 in. (28 mm)	Field Fabricated

NOTE - Some applications may require a field-provided 7/8" to 1-1/8" adapter.

### New or Replacement Line Set

This section provides information on new installation or replacement of existing line set. If a new or replacement line set is not required, then proceed to Brazing Connections on page 17.

Field refrigerant piping consists of liquid and suction lines from the outdoor unit (brazed connections) to the indoor unit coil (flare or brazed connections). Use Lennox L15 (brazed, non-flare) series line set, or use field-fabricated refrigerant lines as listed in table 3.

#### LINE SET JOINTS - FURNACE APPLICATION

Evaporator primary line set joints in all applications shall have a line set joint sleeve. Evaporator primary line sets should not have additional joints not covered by line set joint sleeve.

**If additional joints are present**, the system installation shall comply with one of the options below:

**Option 1** - Furnace is installed as a direct vent appliance;

**Option 2** - Furnace/Evaporator installation is in a space greater than the minimum conditioned area (A<sub>min</sub>);

**Option 3** - Furnace/Evaporator installation is connected to a space greater than the minimum conditioned area (A<sub>min</sub>) through an opening of at least 15 in<sup>2</sup> (4-inch diameter hole equivalent) located below the level of the furnace burners;

**Option 4** - Have a second refrigerant detection sensor installed below the level of the burners (see Secondary Sensor Installation section).

#### Multiple Systems Installed in Same Space

For any A2L refrigerant system with additional joints not covered by line set joint sleeves, each system in the same space must have refrigerant detection sensor installed below the level of the burners (see Secondary Sensor Installation section). If all the systems in the same space are installed with direct vent application, then additional refrigerant detection sensor is not needed

#### Secondary Sensor Installation

If secondary refrigerant sensor is required, it shall be mounted as follows:

Upflow Applications: Mounted on an unused side furnace return air connection at least 9 inches above the floor and within 9 inches from front of furnace.

Connect the refrigerant sensor to the second sensor input on the RDS Control. Refer to the instructions provided with the sensor or the RDS controller to enable the second sensor.

**NOTE** - When installing refrigerant lines longer than 50 feet, refer to the Refrigerant Piping Design and Fabrication Guidelines manual available on [LennoxPros.com](http://LennoxPros.com) (Corp. 9351-L9), or contact the Technical Support Department Product Application group for assistance.

<b>⚠ WARNING</b>	
	When using a high pressure gas such as nitrogen to pressurize a refrigeration or air conditioning system, use a regulator that can control the pressure down to 1 or 2 psig (6.9 to 13.8 kPa).

<b>⚠ WARNING</b>	
Refrigerant can be harmful if it is inhaled. Refrigerant must be used and recovered responsibly.	
Failure to follow this warning may result in personal injury or death.	

To obtain the correct information from Lennox, be sure to communicate the following points:

- Model (ML13KC1) and size of unit (e.g. -060).
- Line set diameters for the unit being installed as listed in table 1 and total length of installation.
- Number of elbows and if there is a rise or drop of the piping.

If refrigerant lines are routed through a wall, seal and isolate the opening so vibration is not transmitted to the building. Pay close attention to line set isolation during installation of any HVAC system. When properly isolated

from building structures (walls, ceilings, floors), the refrigerant lines will not create unnecessary vibration and subsequent sounds.

<b>⚠ WARNING</b>	
	<b>Fire, Explosion and Personal Safety hazard.</b> Failure to follow this warning could result in damage, personal injury or death. Never use oxygen to pressurize or purge refrigeration lines. Oxygen, when exposed to a spark or open flame, can cause fire and/or an explosion, that could result in property damage, personal injury or death.

The compressor is charged with sufficient Polyol ester oil for line set lengths up to 50 feet. Recommend adding oil to system based on the amount of refrigerant charge in the system. No need to add oil in a system with 20 pounds of refrigerant or less. For systems over 20 pounds - add one ounce for every five pounds of refrigerant over 20 pounds. Recommended topping-off POE oils are Mobil EAL ARCTIC 22 CC or ICI EMKARATE RL32CF.

#### LIQUID LINE FILTER DRIER INSTALLATION

The provided filter drier must be field installed outdoors in the liquid line between the units liquid line service valve and before the liquid line enters the structure. It is not recommended to install the liquid line filter drier indoors due to additional braze joints required. This filter drier must be installed to ensure a clean, moisture-free system. Failure to install the filter drier will void the warranty. A replacement filter drier is available from Lennox. See Brazing Connections on page for special procedures on brazing filter drier connections to the liquid line.

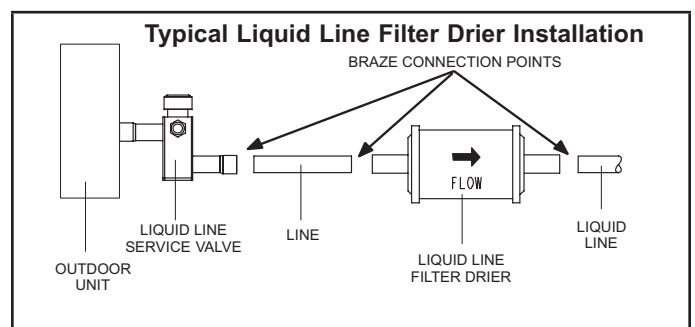

**FIGURE 6. Typical Liquid Line Filter Drier Installation**

# LINE SET

**IMPORTANT** — Refrigerant lines must not contact structure.

## INSTALLATION

**Line Set Isolation** - The following illustrations are examples of proper refrigerant line set isolation:

### REFRIGERANT LINE SET — TRANSITION FROM VERTICAL TO HORIZONTAL

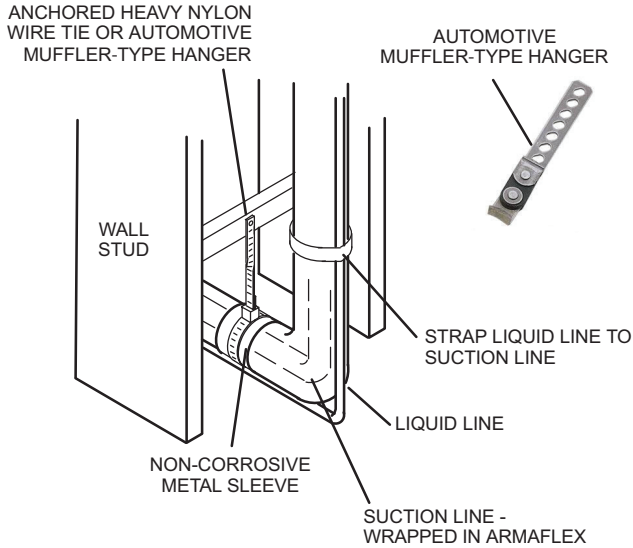

### REFRIGERANT LINE SET — INSTALLING VERTICAL RUNS (NEW CONSTRUCTION SHOWN)

**NOTE** - Insulate liquid line when it is routed through areas where the surrounding ambient temperature could become higher than the temperature of the liquid line or when pressure drop is equal to or greater than 20 psig.

**IMPORTANT** - Refrigerant lines must not contact wall

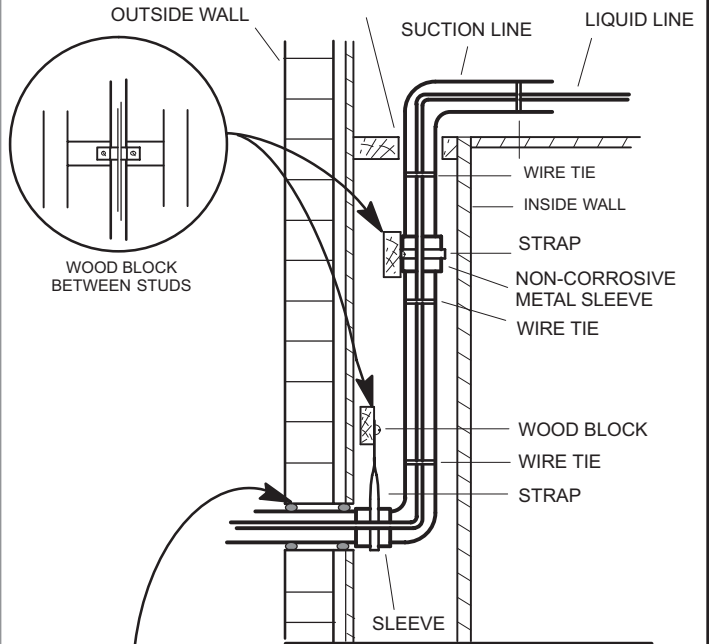

### REFRIGERANT LINE SET — INSTALLING HORIZONTAL RUNS

To hang line set from joist or rafter, use either metal strapping material or anchored heavy nylon wire ties.

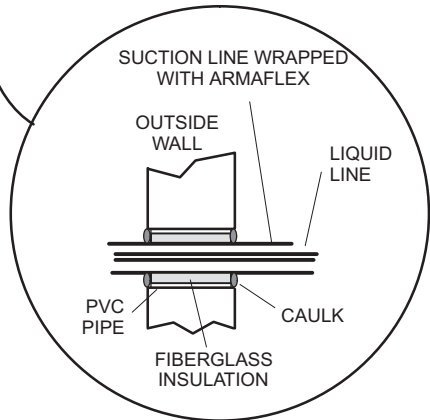
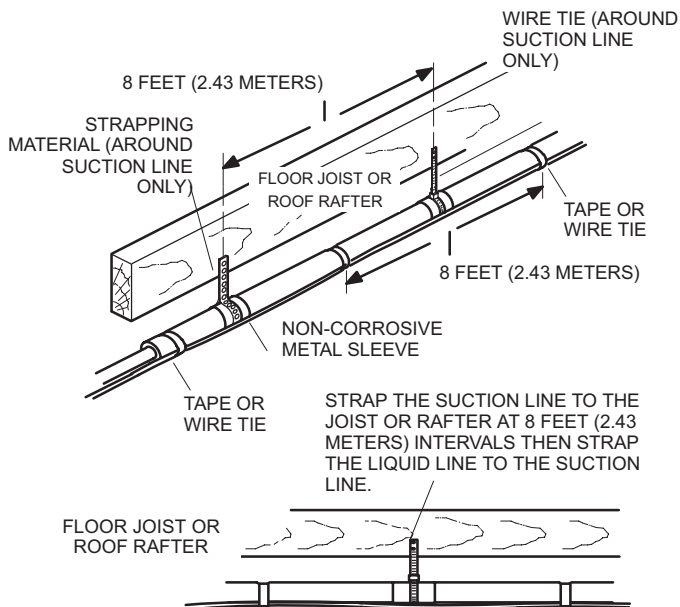

**NOTE** - Similar installation practices should be used if line set is to be installed on exterior of outside wall.

FIGURE 7. Line Set Installation

## Brazing Connections

Use the procedures outlined in figures 8 and 9 for brazing line set connections to service valves.

### WARNING



Danger of fire. Bleeding the refrigerant charge from only the high side may result in pressurization of the low side shell and suction tubing. Application of a brazing torch to a pressurized system may result in ignition of the refrigerant and oil mixture. Check the high and low pressures before applying heat.

### CAUTION

Brazing alloys and flux contain materials which are hazardous to your health.

Avoid breathing vapors or fumes from brazing operations. Perform operations only in well-ventilated areas.

Wear gloves and protective goggles or face shield to protect against burns.

Wash hands with soap and water after handling brazing alloys and flux.

### IMPORTANT

Allow braze joint to cool before removing the wet rag from the service valve. Temperatures above 250°F can damage valve seals.

### IMPORTANT

Use silver alloy brazing rods with 5% minimum silver alloy for copper-to-copper brazing. Use 45% minimum alloy for copper-to-brass and copper-to-steel brazing.

### IMPORTANT

If this unit is being matched with an approved line set it must be flushed prior to installation. Take care to empty all existing traps. Polyol ester (POE) oils are used in Lennox units charged with R-454B refrigerant. Residual mineral oil can act as an insulator, preventing proper heat transfer. It can also clog the expansion device and reduce system performance and capacity.

Failure to properly flush the system, per this instruction and the detailed Installation and Service Procedures manual will void the warranty.

# 1 CUT AND DEBUR

Cut ends of the refrigerant lines square (free from nicks or dents) and debur the ends. The pipe must remain round. Do not crimp end of the line.

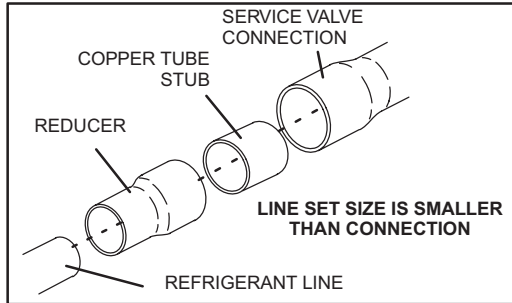
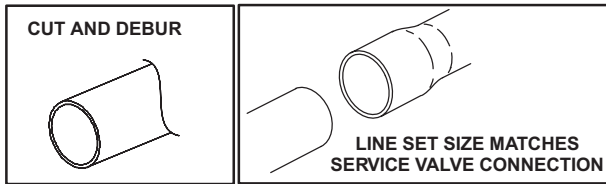

DO NOT CRIMP SERVICE VALVE CONNECTOR WHEN PIPE IS SMALLER THAN CONNECTION

# 2 CAP AND CORE REMOVAL

Remove service cap and core from both the suction / vapor and liquid line service ports.

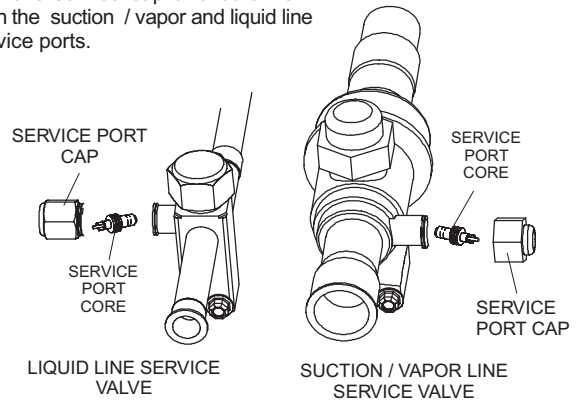

# 3 ATTACH THE MANIFOLD GAUGE SET FOR BRAZING LIQUID AND SUCTION / VAPOR LINE SERVICE VALVES

Flow regulated nitrogen (at 1 to 2 psig) through the low-side refrigeration gauge set into the liquid line service port valve, and out of the suction / vapor line service port valve.

- A Connect gauge set low pressure side to liquid line service valve (service port).
- B Connect gauge set center port to bottle of nitrogen with regulator.
- C Remove core from valve in suction / vapor line service port to allow nitrogen to escape.

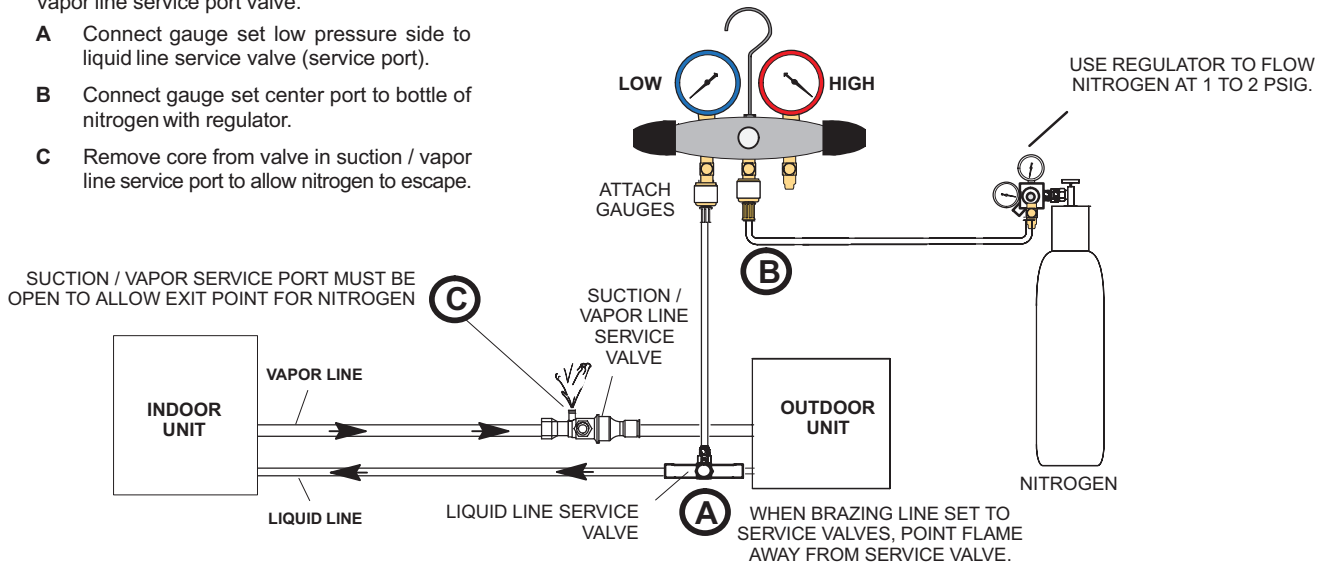

FIGURE 8. Brazing Procedures

## 4 WRAP SERVICE VALVES

To help protect service valve seals during brazing, wrap water-saturated cloths around service valve bodies and copper tube stubs. Use additional water-saturated cloths underneath the valve body to protect the base paint.

## 5 FLOW NITROGEN

Flow regulated nitrogen (at 1 to 2 psig) through the refrigeration gauge set into the valve stem port connection on the liquid service valve and out of the suction / vapor valve stem port. See steps 3A, 3B and 3C on manifold gauge set connections.

## 6 BRAZE LINE SET

Wrap both service valves with water-saturated cloths as illustrated here and as mentioned in step 4, before brazing to line set. Cloths must remain water-saturated throughout the brazing and cool-down process.

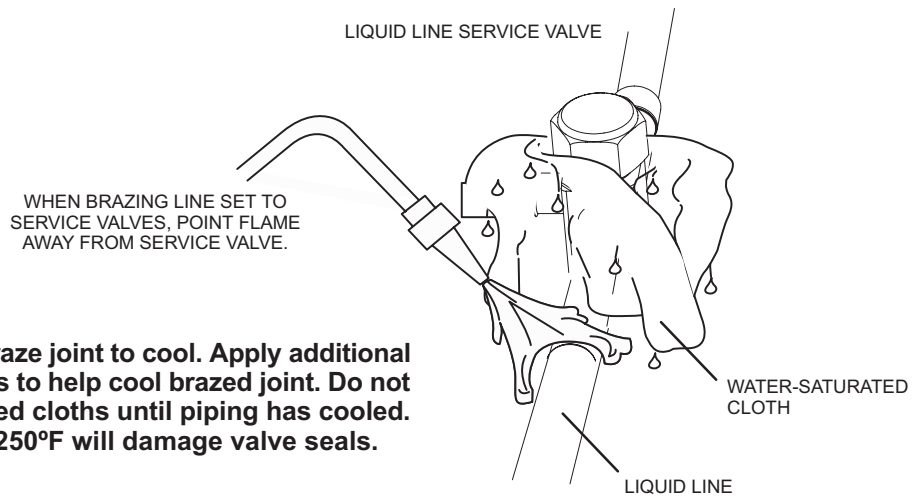

**IMPORTANT - Allow braze joint to cool. Apply additional water-saturated cloths to help cool brazed joint. Do not remove water-saturated cloths until piping has cooled. Temperatures above 250°F will damage valve seals.**

### WARNING

**FIRE, PERSONAL INJURY, OR PROPERTY DAMAGE** may result if you do not wrap a water-saturated cloth around both liquid and suction line service valve bodies and copper tube stub while brazing the line set! The braze, when complete, must be quenched with water to absorb any residual heat.

Do not open service valves until refrigerant lines and indoor coil have been leak-tested and evacuated. Refer to Installation and Service Procedures manual found on [LennoxPros.com](http://LennoxPros.com).

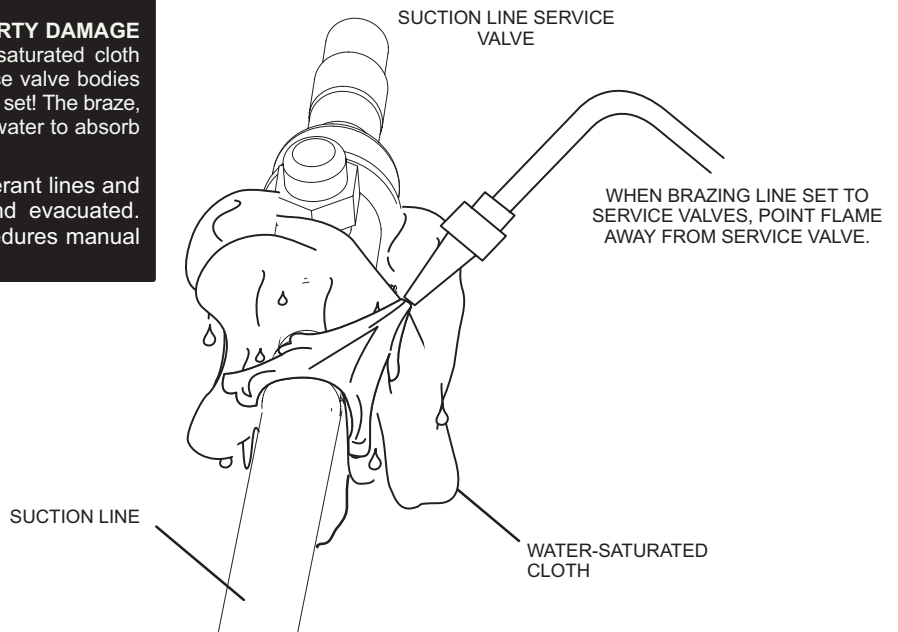

## 7 PREPARATION FOR NEXT STEP

Disconnect manifold gauge set from service ports after all connections have been brazed. Apply additional water-saturated cloths to both service valves to cool piping. Once piping is cool, remove all water-saturated cloths.

**FIGURE 9. Brazing Procedures (Cont'd)**

## Flushing Line Set and Indoor Coil

### 1 TYPICAL EXISTING EXPANSION VALVE REMOVAL PROCEDURE (UNCASED COIL SHOWN)

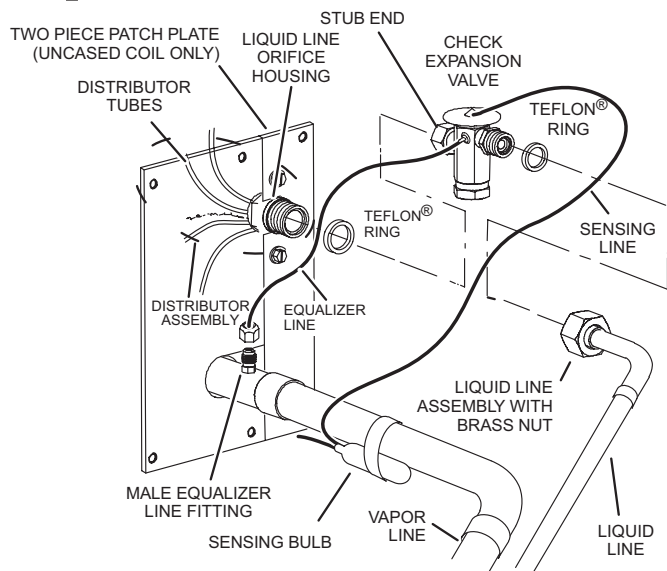

- A On fully cased coils, remove the coil access and plumbing panels.
- B Remove any shipping clamps holding the liquid line and distributor assembly.
- C Disconnect the equalizer line from the check expansion valve equalizer line fitting on the vapor line.
- D Remove the vapor line sensing bulb.
- E Disconnect the liquid line from the check expansion valve at the liquid line assembly.
- F Disconnect the check expansion valve from the liquid line orifice housing. Take care not to twist or damage distributor tubes during this process.
- G Remove and discard check expansion valve and the two Teflon® rings.
- H Use a field-provided fitting to temporary reconnect the liquid line to the indoor unit's liquid line orifice housing.

### 2 CONNECT GAUGES AND EQUIPMENT FOR FLUSHING PROCEDURE

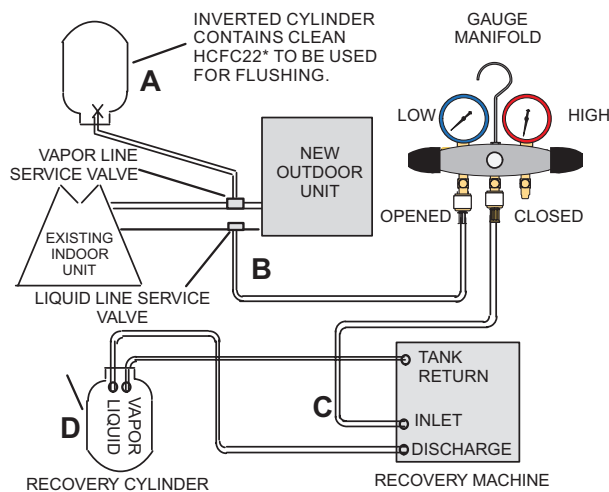

- A Inverted HCFC-22 cylinder with clean refrigerant\* to the vapor service valve.
- B HCFC-22 gauge set (low side) to the liquid line valve.
- C HCFC-22 gauge set center port to inlet on the recovery machine with an empty recovery tank to the gauge set.
- D Connect recovery tank to recovery machines per machine instructions.

### 3 FLUSHING LINE SET

The line set and indoor unit coil must be flushed with at least the same amount of clean refrigerant\* that previously charged the system. Check the charge in the flushing cylinder before proceeding.

- A Set the recovery machine for liquid recovery and start the recovery machine. Open the gauge set valves to allow the recovery machine to pull a vacuum on the existing system line set and indoor unit coil.
- B Invert the cylinder of clean HCFC-22\* and open its valve to allow liquid refrigerant to flow into the system through the vapor line valve. Allow the refrigerant to pass from the cylinder and through the line set and the indoor unit coil before it enters the recovery machine.
- C After all of the liquid refrigerant has been recovered, switch the recovery machine to vapor recovery so that all of the HCFC-22 vapor is recovered. Allow the recovery machine to pull the system down to 0.
- D Close the valve on the inverted HCFC-22 drum and the gauge set valves. Pump the remaining refrigerant out of the recovery machine and turn the machine off.

**\*IMPORTANT - Clean refrigerant is any refrigerant in a system that has not had compressor burn out. If the system has experienced burn out, it is recommended that the existing line set and indoor coil be replaced.**

FIGURE 10. Removing Metering Device and Flushing

## Installing Indoor Metering Device

This outdoor unit is designed for use in systems that use an expansion valve metering device (purchased separately) at the indoor coil. See the ML13KC1 Product Specifications bulletin (EHB) for approved expansion valve kit match ups.

The expansion valve unit can be installed inside of the cabinet or external to the indoor coil. In applications where an uncased coil is being installed in a field-provided plenum, install the expansion valve in a manner that will provide access for field servicing of the expansion valve. Refer to below illustration for reference during installation of expansion valve unit.

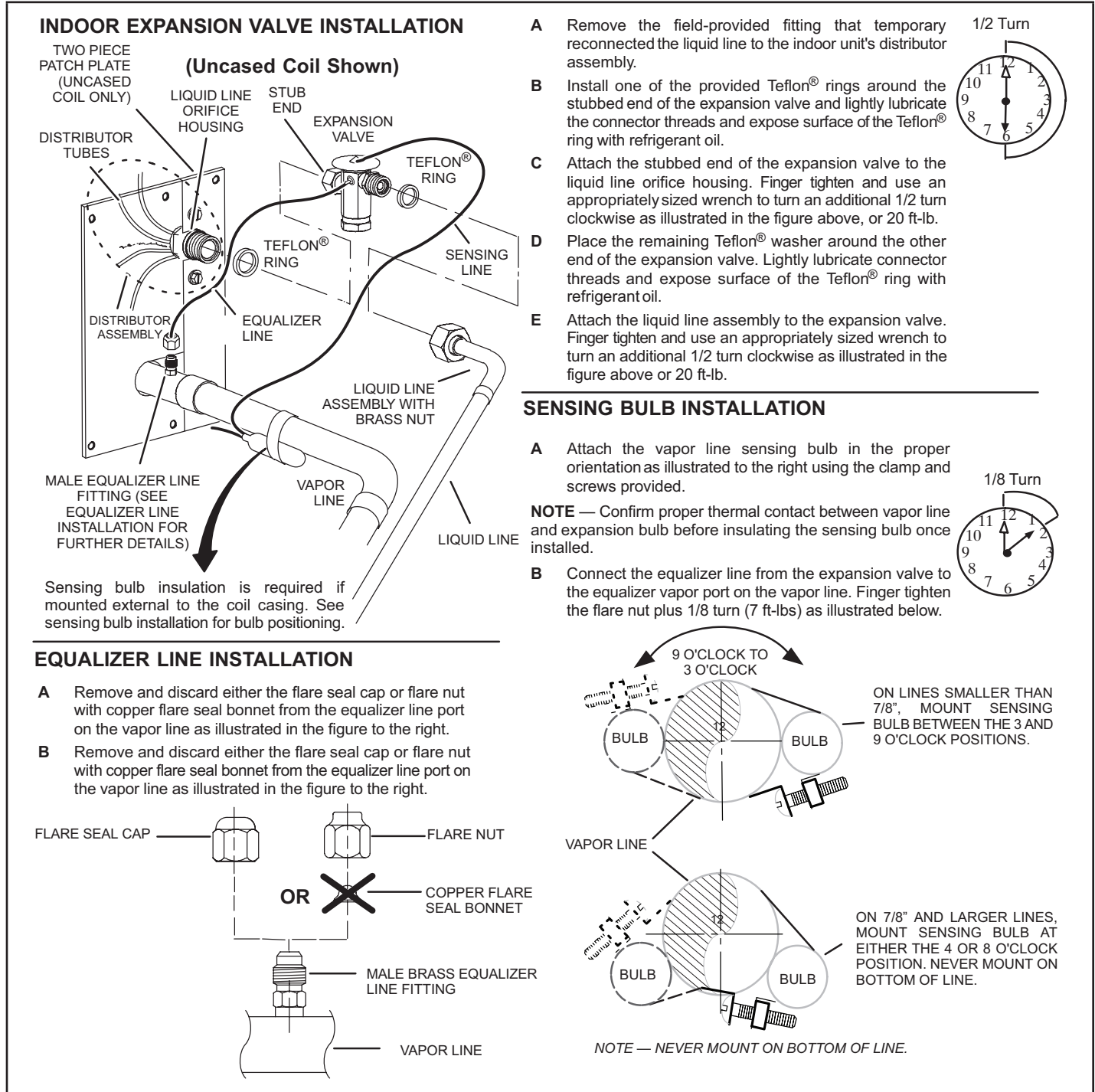

FIGURE 11

## Leak Testing the System

### ⚠ IMPORTANT

Leak detector must be capable of sensing A2L refrigerant.

### ⚠ IMPORTANT

The Environmental Protection Agency (EPA) prohibits the intentional venting of HFC refrigerants during maintenance, service, repair and disposal of appliance. Approved methods of recovery, recycling or reclaiming must be followed.

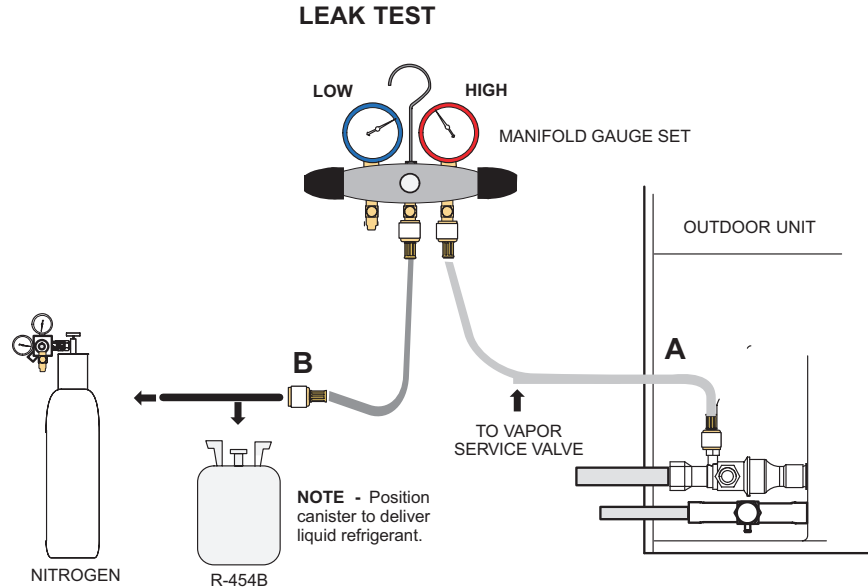

## 1 CONNECT GAUGE SET

**A** - Connect the high pressure hose of an R-454B manifold gauge set to the vapor valve service port.

**NOTE** - Normally, the high pressure hose is connected to the liquid line port. However, connecting it to the vapor port better protects the manifold gauge set from high pressure damage.

**B** - With both manifold valves closed, connect the cylinder of R-454B refrigerant to the center port of the manifold gauge set.

**NOTE** - Later in the procedure, the R-454B container will be replaced by the nitrogen container.

## 2 TEST FOR LEAKS

After the line set has been connected to the indoor and outdoor units, check the line set connections and indoor unit for leaks. Use the following procedure to test for leaks:

**A** - With both manifold valves closed, connect the cylinder of R-454B refrigerant to the center port of the manifold gauge set. Open the valve on the R-454B cylinder (vapor only).

**B** - Open the high pressure side of the manifold to allow R-454B into the line set and indoor unit. Weigh in a trace amount of R-454B. [A trace amount is a maximum of two ounces (57 g) refrigerant or three pounds (31 kPa) pressure.] Close the valve on the R-454B cylinder and the valve on the high pressure side of the manifold gauge set. Disconnect the R-454B cylinder.

**C** - Connect a cylinder of nitrogen with a pressure regulating valve to the center port of the manifold gauge set.

**D** - Adjust nitrogen pressure to 160 psig (1103 kPa). Open the valve on the high side of the manifold gauge set in order to pressurize the line set and the indoor unit.

**E** - After a few minutes, open one of the service valve ports and verify that the refrigerant added to the system earlier is measurable with a leak detector. Once leak detector is confirmed operational, leak check the entire system (field joints and line set included) to a sensitivity of 5 grams per year of refrigerant.

**F** - After leak testing, disconnect gauges from service ports.

**FIGURE 12. System Leak Test**

## Evacuating Line Set and Indoor Coil

### 3 CONNECT GAUGE SET

**NOTE** - Remove cores from service valves (if not already done).

- A - Connect low side of manifold gauge set with 1/4 SAE in-line tee to vapor line service valve
- B - Connect high side of manifold gauge set to liquid line service valve
- C - Connect available micron gauge connector on the 1/4 SAE in-line tee.
- D - Connect the vacuum pump (with vacuum gauge) to the center port of the manifold gauge set. The center port line will be used later for both the R454B and nitrogen containers.

**NOTE** - Position canister to deliver liquid refrigerant.

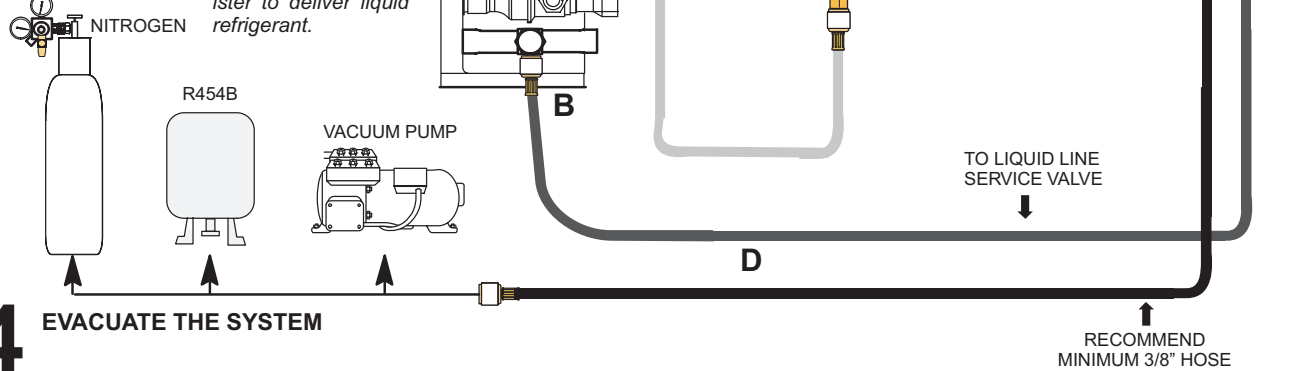

### 4 EVACUATE THE SYSTEM

- A - Open both manifold valves and start the vacuum pump.
- B - Evacuate the line set and indoor unit to an **absolute pressure** of 23,000 microns (29.01 inches of mercury).
  - NOTE** - During the early stages of evacuation, it is desirable to close the manifold gauge valve at least once. A rapid rise in pressure indicates a relatively large leak. If this occurs, **repeat the leak testing procedure**.
  - NOTE** - The term **absolute pressure** means the total actual pressure above absolute zero within a given volume or system. Absolute pressure in a vacuum is equal to atmospheric pressure minus vacuum pressure.
- C - When the absolute pressure reaches 23,000 microns (29.01 inches of mercury), perform the following:
  - Close manifold gauge valves.
  - Close valve on vacuum pump.
  - Turn off vacuum pump.
  - Disconnect manifold gauge center port hose from vacuum pump.
  - Attach manifold center port hose to a nitrogen cylinder with pressure regulator set to 160 psig (1103 kPa) and purge the hose.
  - Open manifold gauge valves to break the vacuum in the line set and indoor unit.
  - Close manifold gauge valves.
- D - Shut off the nitrogen cylinder and remove the manifold gauge hose from the cylinder. Open the manifold gauge valves to release the nitrogen from the line set and indoor unit.
- E - Reconnect the manifold gauge to the vacuum pump, turn the pump on, and continue to evacuate the line set and indoor unit until the absolute pressure does not rise above 500 microns (29.9 inches of mercury) within a 20-minute period after shutting off the vacuum pump and closing the manifold gauge valves.
- F - When the absolute pressure requirement above has been met, disconnect the manifold hose from the vacuum pump and connect it to a cylinder of R454B positioned to deliver liquid refrigerant. Open the manifold gauge valve 1 to 2 psig in order to release the vacuum in the line set and indoor unit.
- G - Perform the following:
  - Close manifold gauge valves.
  - Shut off R454B cylinder.
  - Reinstall service valve cores by removing manifold hose from service valve. Quickly install cores with core tool while maintaining a positive system pressure.
  - Replace stem caps and finger tighten them, then tighten an additional one-sixth (1/6) of a turn as illustrated.

### WARNING !

**Possible equipment damage.**

**Avoid deep vacuum operation. Do not use compressors to evacuate a system. Extremely low vacuum can cause internal arcing and compressor failure. Damage caused by deep vacuum operation will void warranty.**

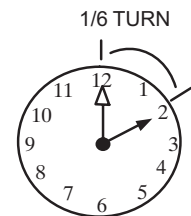

FIGURE 13. Evacuating the System

## ⚠ IMPORTANT

Use a thermocouple or thermistor electronic vacuum gauge that is calibrated in microns. Use an instrument capable of accurately measuring down to 50 microns.

## ⚠ WARNING

Possible equipment damage.

Avoid deep vacuum operation. Do not use compressors to evacuate a system. Extremely low vacuum can cause internal arcing and compressor failure. Damage caused by deep vacuum operation will void warranty.

Evacuating the system of non-condensables is critical for proper operation of the unit. Non-condensables are defined as any gas that will not condense under temperatures and pressures present during operation of an air conditioning system. Non-condensables and water suction combine with refrigerant to produce substances that corrode copper piping and compressor parts.

Unit must be installed with Lennox approved refrigerant detection system (RDS) and sensor.

Do not operate system until refrigerant detection system is verified to be in good working order.

## Electrical – Circuit Sizing and Wire Routing

In the U.S.A., wiring must conform with current local codes and the current National Electric Code (NEC). In Canada, wiring must conform with current local codes and the current Canadian Electrical Code (CEC).

Refer to the furnace or air handler installation instructions for additional wiring application diagrams and refer to unit nameplate for minimum circuit ampacity and maximum overcurrent protection size.

### 24VAC TRANSFORMER

Use the transformer provided with the furnace or air handler for low-voltage control power (24VAC - 40 VA minimum).

## ⚠ WARNING

Fire Hazard. Use of aluminum wire with this product may result in a fire, causing property damage, severe injury or death. Use copper wire only with this product.

## ⚠ WARNING

Failure to use properly sized wiring and circuit breaker may result in property damage. Size wiring and circuit breaker(s) per Product Specifications bulletin (EHB) and unit rating plate.

### SIZE CIRCUIT AND INSTALL SERVICE DISCONNECT SWITCH

Refer to the unit nameplate for minimum circuit ampacity, and maximum fuse or circuit breaker (HACR per NEC). Install power wiring and properly sized disconnect switch.

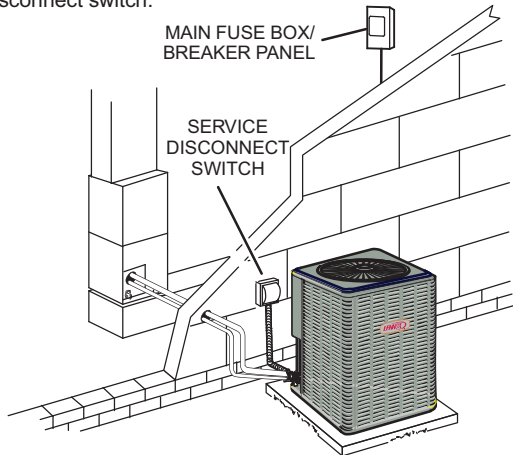

*NOTE — Units are approved for use only with copper conductors. Ground unit at disconnect switch or to an earth ground.*

### INSTALL THERMOSTAT

Install room thermostat (ordered separately) on an inside wall approximately in the center of the conditioned area and 5 feet (1.5m) from the floor. It should not be installed on an outside wall or where it can be affected by sunlight or drafts.

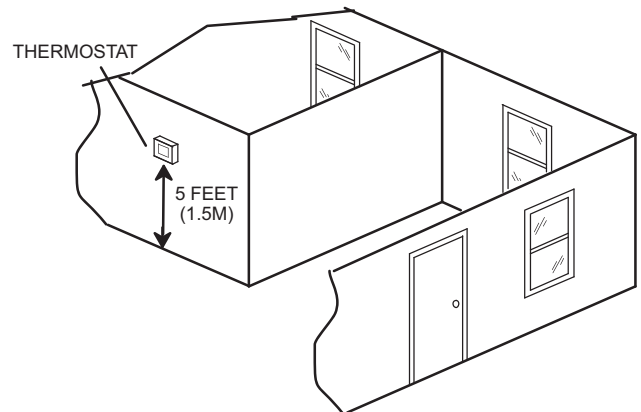

*NOTE — 24VAC, Class II circuit connections are made in the control panel.*

## ROUTING HIGH VOLTAGE, GROUND AND CONTROL WIRING

### HIGH VOLTAGE / GROUND WIRES

Any excess high voltage field wiring should be trimmed and secured away from any low voltage field wiring. To facilitate a conduit, a cutout is located in the bottom of the control panel. Connect conduit to the control panel using a proper conduit fitting.

**NOTE** - Wire tie provides low voltage control wire strain relief and maintains separation of field-installed low and high voltage circuits.

**NOTE** - For proper voltages, select thermostat wire (control wires) gauge per table above.

**NOTE** - Do not bundle any excess 24VAC control wires inside control panel.

Install low voltage wiring from outdoor to indoor unit and from thermostat to indoor unit as illustrated.

**A** - Run 24VAC control wires through hole with grommet and secure with provided wire tie.

**B** - Make 24VAC thermostat wire connections. Locate the two wires from the contactor and make connection using field-provided wire nuts:

- **Yellow to Y1**
- **Black to C (common)**

WIRE RUN LENGTH	AWG#	INSULATION TYPE
LESS THAN 100' (30 METERS)	18	TEMPERATURE RATING
MORE THAN 100' (30 METERS)	16	35°C MINIMUM.

**FIGURE 14. Typical Wiring**

### Single-Stage Outdoor Unit with Single-Stage Indoor Unit

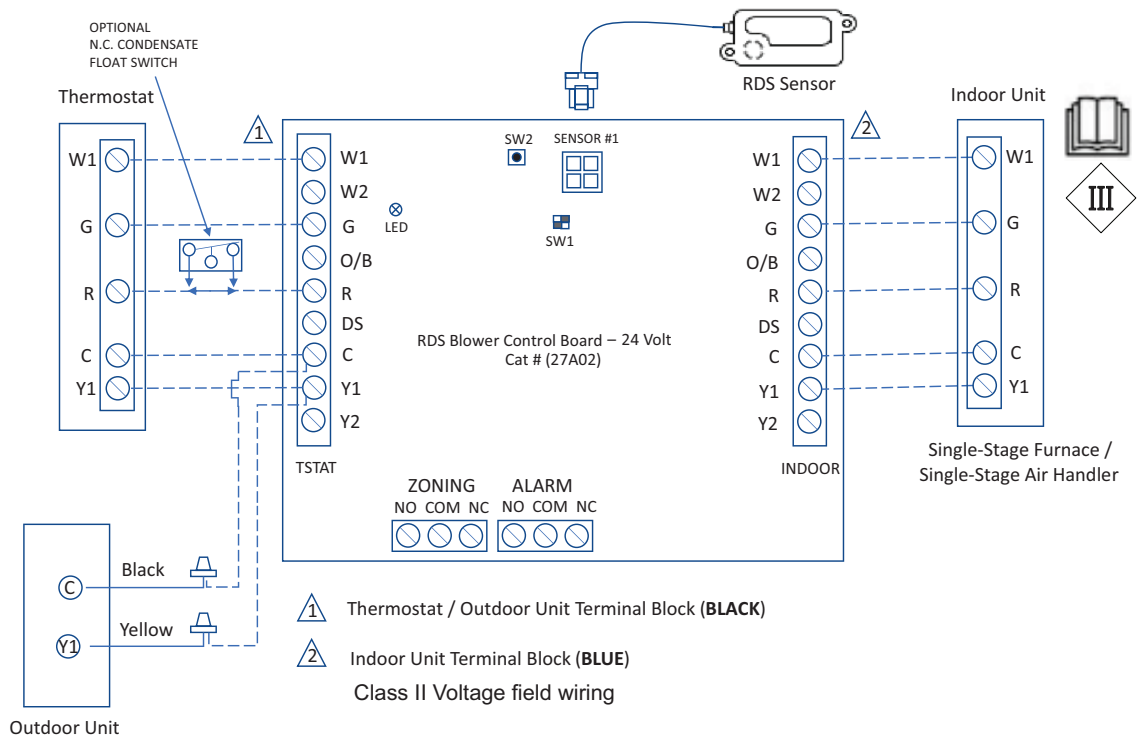

**FIGURE 15. Typical Wiring**

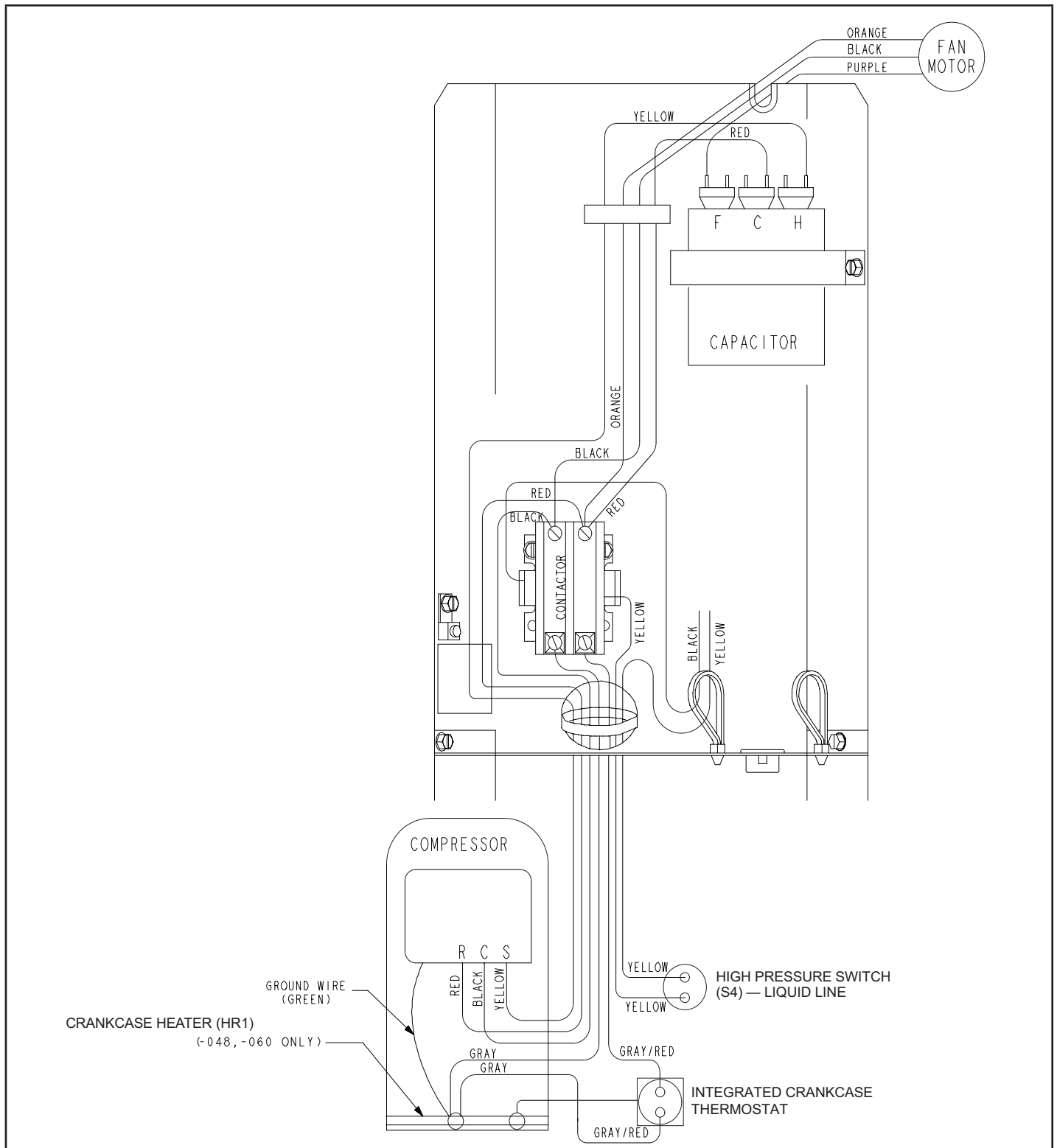

**FIGURE 16. Typical Factory Wiring Diagram – -018, -024, -030, -036, -048, and -060 Units Only**

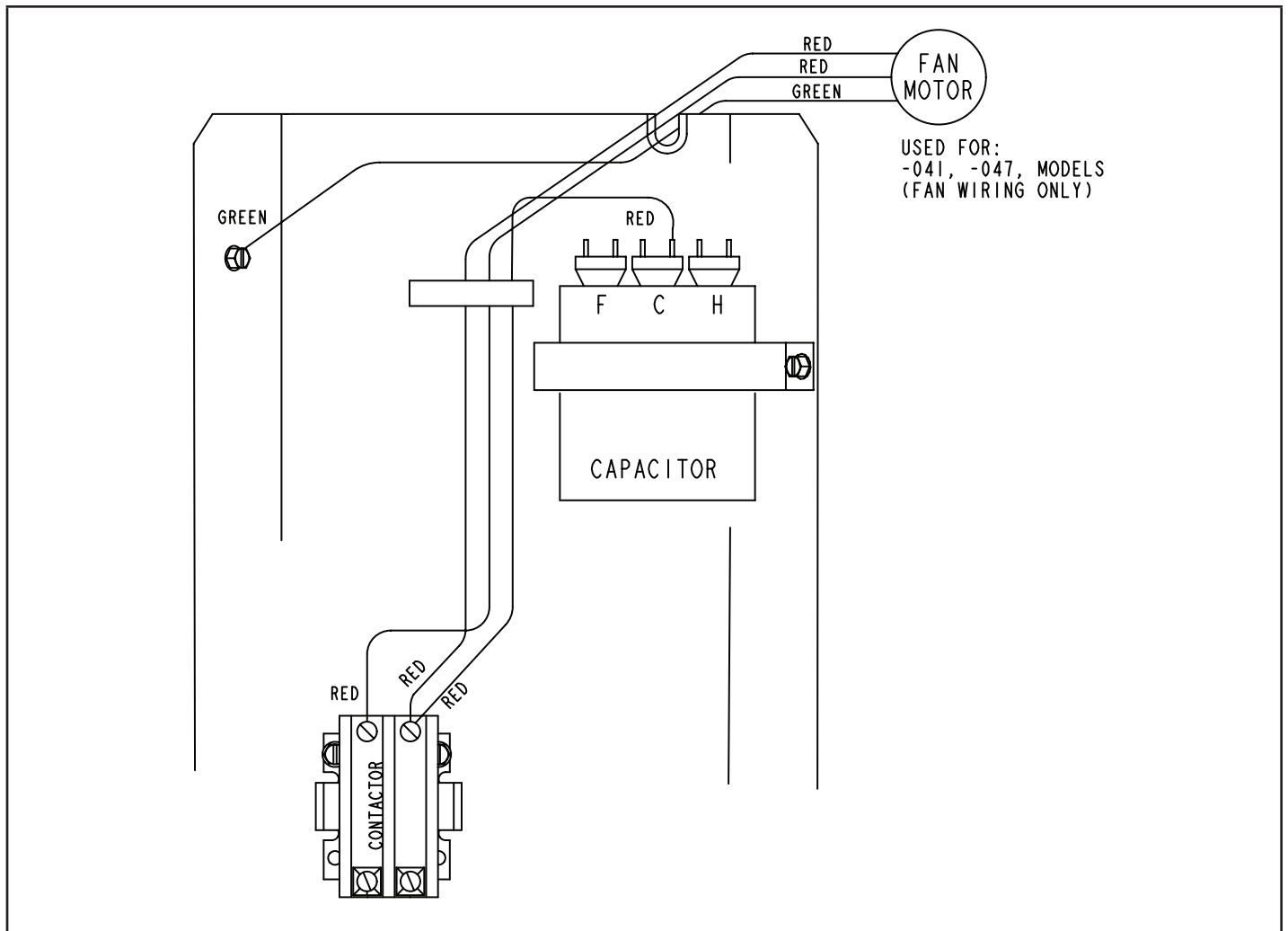

**FIGURE 17. Typical Factory Wiring – -042 Units Only**

## System Operation

### IMPORTANT

Some scroll compressors have an internal vacuum protector that will unload scrolls when suction pressure goes below 20 psig. A hissing sound will be heard when the compressor is running unloaded. Protector will reset when low pressure in system rises above 40 psig. **DO NOT REPLACE COMPRESSOR.**

The outdoor unit and indoor blower will cycle on and off as dictated by demands from the room thermostat. When the thermostat's blower switch is in the **ON** position, the indoor blower will operate continuously.

#### HIGH PRESSURE SWITCH (S4)

ML13KC1 units are equipped with a high-pressure switch that is factory-wired and located in the liquid line.

The switch is a Single Pole, Single Throw (SPST), auto-reset switch which is normally closed and removes power from the compressor when discharge pressure rises above factory setting at  $590 \pm 10$  psig; resets at  $418 \pm 5$  psig.

#### CRANKCASE HEATER (HR1) AND THERMOSTAT (S40)

Compressors in some models are equipped with a 40 watt or 70 watt, belly band type crankcase heater. HR1 prevents liquid from accumulating in the compressor. HR1 is controlled by a single pole, single through thermostat switch (S40) located on the belly band (see figure 1 for location).

When Compressor Shell temperature drops below  $50^{\circ}$  F the thermostat closes energizing HR1. The thermostat will open, de-energizing HR1 once Compressor Shell temperature reaches  $70^{\circ}$  F.

## Maintenance

Your heating and air conditioning system should be inspected and maintained yearly (before the start of the cooling and heating seasons) by a licensed professional HVAC technician. You can expect the technician to check the following items. **These checks may only be conducted by a licensed professional HVAC technician.**

#### Outdoor Unit

1. Inspect component wiring for loose, worn or damaged connections. Also check for any rubbing or pinching of wires. Confirm proper voltage plus amperage of outdoor unit.
2. Check the cleanliness of outdoor fan and blade assemblies. Check condition of fan blades (cracks). Clean or replace them, if necessary.
3. Inspect base pan drains for debris and clean as necessary.
4. Inspect the condition of refrigerant piping and confirm that pipes are not rubbing copper-to-copper. Also, check the condition of the insulation on the refrigerant lines. Repair, correct, or replace as necessary.

5. Test capacitor. Replace as necessary.
6. Inspect contactor contacts for pitting or burn marks. Replace as necessary.
7. Check outdoor fan motor for worn bearings/bushings. Replace as necessary.
8. Inspect and clean outdoor coils, if necessary and note any damage to coils or signs of leakage.

### NOTICE !

**Failure to follow instructions will cause damage to the unit.**

**This unit is equipped with an aluminum coil. Aluminum coils may be damaged by exposure to solutions with a pH below 5 or above 9. The aluminum coil should be cleaned using potable water at a moderate pressure (less than 50psi). If the coil cannot be cleaned using water alone, Lennox recommends use of a coil cleaner with a pH in the range of 5 to 9. The coil must be rinsed thoroughly after cleaning.**

**In coastal areas, the coil should be cleaned with potable water several times per year to avoid corrosive buildup (salt).**

#### Indoor Unit (Air Handler or Furnace)

1. Inspect component wiring for loose, worn or damaged connections. Confirm proper voltage plus amperage indoor unit.
2. Inspect and clean or replace air filters in indoor unit.
3. Check the cleanliness of indoor blower and clean blower, if necessary.
4. Inspect the evaporator coil (Indoor) drain pans and condensate drains for rust, debris, obstructions, leaks or cracks. Pour water in pans to confirm proper drainage from the pan through to the outlet of the pipe. Clean or replace as necessary.
5. Inspect and clean evaporator (indoor) coil, if necessary.
6. Inspect the condition of the refrigerant lines and confirm that pipes are not rubbing copper-to-copper. Also, ensure that refrigerant pipes are not being affected by indoor air contamination. Check condition of insulation on the refrigerant lines. Repair, correct, or replace as necessary.
7. Inspect the duct system for leaks or other problems. Repair or replace as necessary.
8. Check for bearing/bushing wear on indoor blower motor. Replace as necessary.
9. Indoor unit inspections of gas- or oil-fired furnaces will also include inspection and cleaning of the burners, and a full inspection of the gas valve, heat exchanger and flue (exhaust) system.
10. Check functionality of refrigerant detection system.
11. Inspect refrigerant detection sensor.

### General System Test with System Operating

1. Your technician should perform a general system test. He will turn on the air conditioner to check operating functions such as the startup and shutoff operation. He will also check for unusual noises or odors, and measure indoor/outdoor temperatures and system pressures as needed.

2. The technician will check the refrigerant charge per the charging sticker information on the outdoor unit.
3. Verify that system total static pressure and airflow settings are within specific operating parameters.
4. Verify correct temperature drop across indoor coil.

Start-Up and Performance Checklist		
Job Name _____	Job no. _____	Date _____
Job Location _____	City _____	State _____
Installer _____	City _____	State _____
Unit Model No. _____	Serial No. _____	Service Technician _____
Nameplate Voltage _____		
Rated Load Ampacity _____	Compressor _____	Outdoor Fan _____
Maximum Fuse or Circuit Breaker _____		
Electrical Connections Tight? <input type="checkbox"/>	Indoor Filter clean? <input type="checkbox"/>	Supply Voltage (Unit Off) _____
Indoor Blower RPM _____	S.P. Drop Over Indoor (Dry) _____	Outdoor Coil Entering Air Temp. _____
Discharge Pressure _____	Suction Pressure _____	Refrigerant Charge Checked? <input type="checkbox"/>
<b>Refrigerant Lines:</b> - Leak Checked? <input type="checkbox"/>	Properly Insulated? <input type="checkbox"/>	Outdoor Fan Checked? <input type="checkbox"/>
<b>Service Valves:</b> --- Fully Opened? <input type="checkbox"/>	Caps Tight? <input type="checkbox"/>	<b>Thermostat</b>
Voltage With Compressor Operating _____	Calibrated? <input type="checkbox"/>	Properly Set? <input type="checkbox"/> Level? <input type="checkbox"/>

# Typical Field Wiring

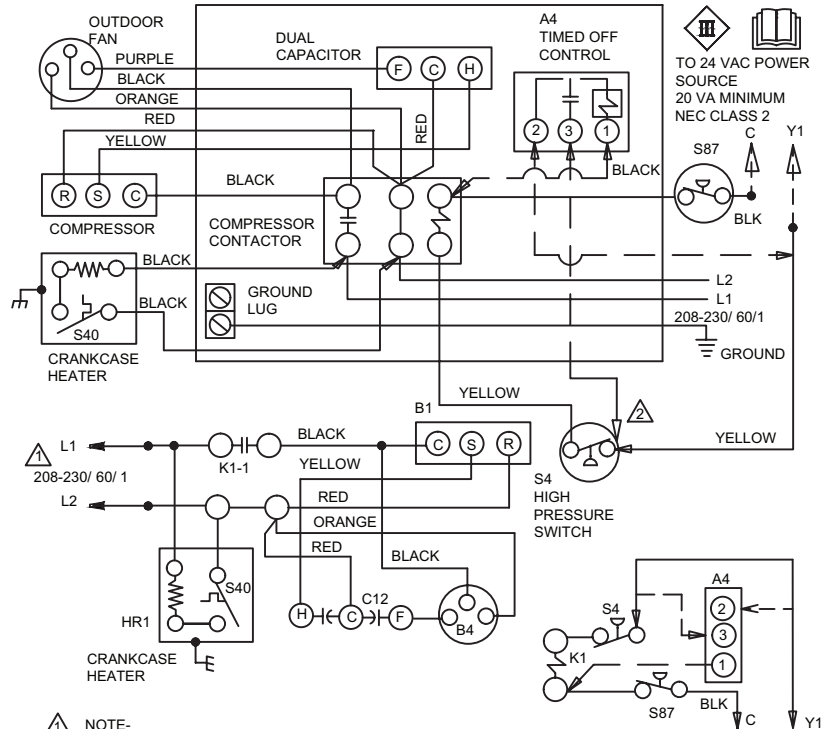

- ⚠ NOTE- FOR USE WITH COPPER CONDUCTORS ONLY. REFER TO UNIT RATING PLATE FOR MINIMUM CIRCUIT AMPACITY AND MAXIMUM OVERCURRENT PROTECTION SIZE
- ⚠ IF USING A4: CONNECT S4 TO TERMINAL 3 ON A4, CONNECT Y1 TO TERMINAL 2 ON A4

NOTE- IF ANY WIRE IN THIS APPLIANCE IS REPLACED, IT MUST BE REPLACED WITH WIRE OF LIKE SIZE, RATING, INSULATION THICKNESS, AND TERMINATION.

— LINE VOLTAGE FIELD INSTALLED  
 - - - CLASS II VOLTAGE FIELD WIRING  
 ← DENOTES OPTIONAL COMPONENTS

KEY	DESCRIPTION
A4	CONTROL-TIMED OFF
B1	COMPRESSOR
B4	MOTOR-OUTDOOR FAN
C12	CAPACITOR-DUAL
HR1	HEATER-CRANKCASE
K1.-1	CONTACTOR-COMPRESSOR
S4	SWITCH-HIGH PRESSURE
S24	SWITCH-LOSS OF CHARGE
S40	TERMOSTAT-CRANKCASE
S87	SWITCH-LOW PRESS, COMP 1

**SINGLE SPEED COOLING MODELS**

Supersedes

**Form No.**  
**538476-01**

© 2011 Litho U.S.A.

**FIGURE 18. Typical Field Wiring – All Units Except -042**

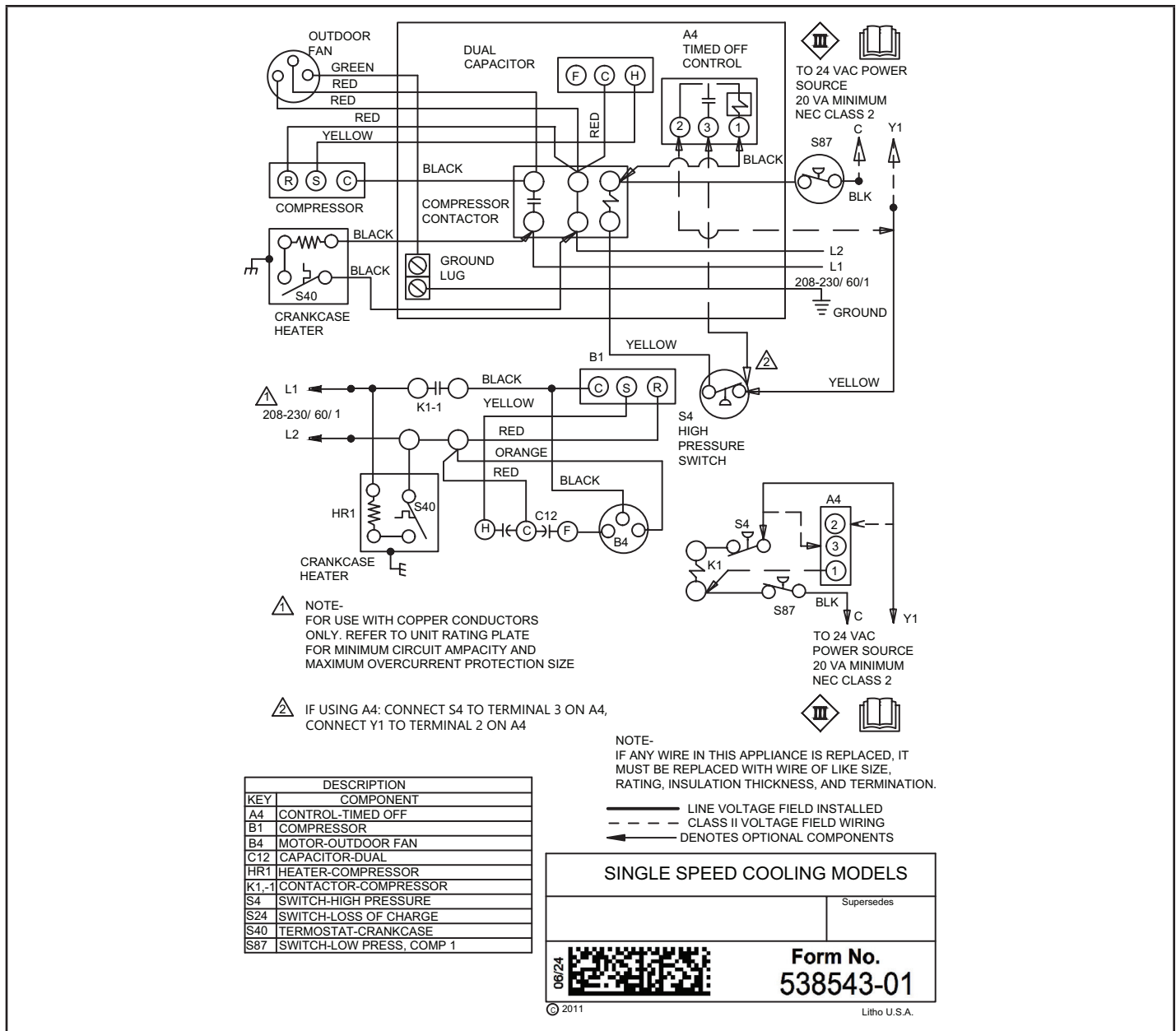

**FIGURE 19. Typical Field Wiring – -042 Unit Only**

**NOTE** – The thermostat used may be electromechanical or electronic.

**NOTE** – Transformer in indoor unit supplies power (24 VAC) to the thermostat and outdoor unit controls.

**COOLING:**

1. Cooling demand initiates at Y1 in the thermostat.
2. 24VAC from indoor unit (Y1) energizes the TOC timed off control (if used) which energizes contactor K1 (provided S4 high pressure switch is closed).
3. K1-1 N.O. closes, energizing compressor (B1) and outdoor fan motor (B4).
4. Compressor (B1) and outdoor fan motor (B4) begin immediate operation..

**END OF COOLING DEMAND:**

5. Cooling demand is satisfied. Terminal Y1 is de-energized.
6. Compressor contactor K1 is de-energized.

7. K1-1 opens and compressor (B1) and outdoor fan motor (B4) are de-energized and stop immediately

**Servicing Units Delivered Void of Charge**

If the outdoor unit is void of refrigerant, clean the system using the procedure described below.

- 1 - Leak test the system using the procedure outlined on page 22.
- 2 - Evacuate the system using procedure outlined on page 23.
- 3 - Use nitrogen to break the vacuum and install a new filter drier in the system.
- 4 - Evacuate the system again using procedure outlined on page 22.
- 5 - Weigh in refrigerant using procedure outlined in figure 23.

## Unit Start-Up

### ⚠ IMPORTANT

If unit is equipped with a crankcase heater, it should be energized 24 hours before unit start-up to prevent compressor damage as a result of slugging.

- 1 - Rotate fan to check for binding.
- 2 - Inspect all factory- and field-installed wiring for loose connections.
- 3 - After evacuation is complete, open both the liquid and vapor line service valves to release the refrigerant charge (contained in outdoor unit) into the system.
- 4 - Replace the stem caps and tighten to the value listed in table 1.
- 5 - Check voltage supply at the disconnect switch. The voltage must be within the range listed on the unit's nameplate. If not, do not start the equipment until you have consulted with the power company and the voltage condition has been corrected.
- 6 - Connect manifold gauge set for testing and charging.

- 7 - Set the thermostat for a cooling demand. Turn on power to the indoor unit and close the outdoor unit disconnect switch to start the unit.
- 8 - Recheck voltage while the unit is running. Power must be within range shown on the nameplate.
- 9 - Check system for sufficient refrigerant by using the procedures that follow.
- 10 - Test functionality of refrigerant detection system.

## System Refrigerant

This section outlines procedures for:

- 1 - Connecting gauge set for testing and charging;
- 2 - Checking and adjusting indoor airflow;
- 3 - Adding or removing refrigerant.

**NOTE** - System fault and lockout codes take precedence over system status codes (cooling, heating operating percentages or defrost/dehumidification).

R454-B is a zeotropic blend, will need to use saturated liquid temperature to calculate liquid subcooling .

Charge unit with liquid only.

## GAUGE SET

### CONNECTIONS FOR TESTING AND CHARGING

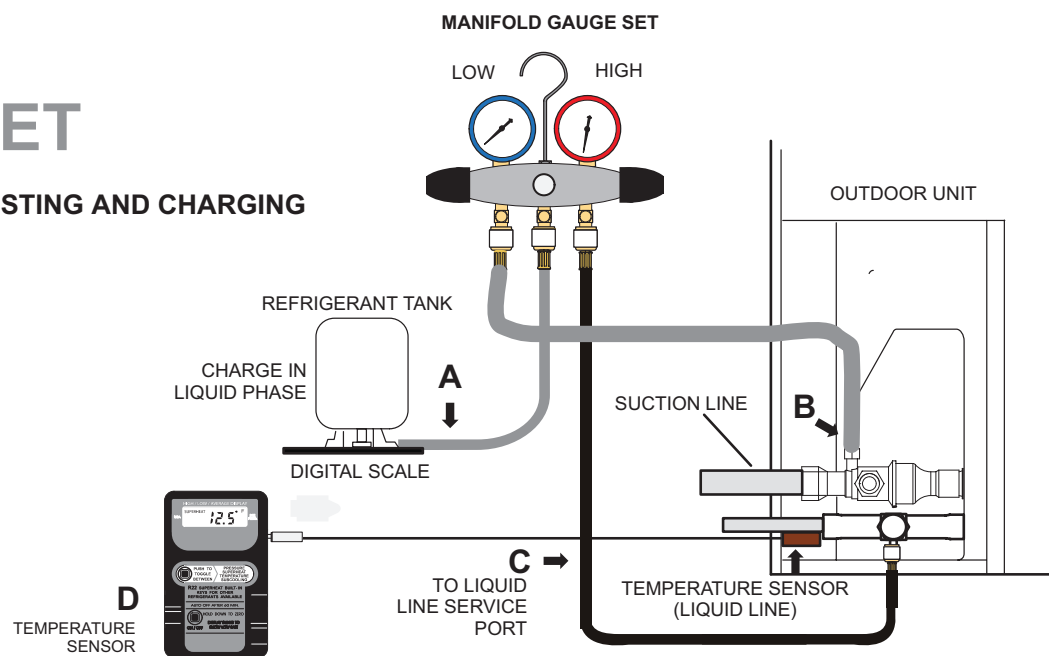

- A. CLOSE MANIFOLD GAUGE SET VALVES AND CONNECT THE CENTER HOSE TO A CYLINDER OF R454B SET FOR LIQUID PHASE CHARGING.
- B. CONNECT THE MANIFOLD GAUGE SET'S LOW PRESSURE SIDE TO THE SUCTION LINE SERVICE PORT.
- C. CONNECT THE MANIFOLD GAUGE SET'S HIGH PRESSURE SIDE TO THE LIQUID LINE SERVICE PORT.
- D. POSITION TEMPERATURE SENSOR ON LIQUID LINE NEAR LIQUID LINE SERVICE PORT.

FIGURE 20. Gauge Set Setup and Connections

## Charging

Verify the unit is electrically grounded before charging the system. Extreme care shall be taken not to overfill the refrigerating system.

Charge should be checked and adjusted using information outlined in this section and in the tables provided on the charging label on the unit's control access panel.

R454B is a zeotropic blend of two refrigerants. At any given refrigerant pressure, R454B will have two saturation temperatures, a saturated liquid temperature and a saturated vapor temperature. See R454B Refrigerant Pressure Temperature Chart in the installation and service manual for saturation temperatures.

R454B units must be charged with liquid refrigerant. Follow conventional charging procedures when charging the system. The technician is required to mark the total charge of the installed system on the unit nameplate, which includes the nameplate charge (factory charge) and additional charge that is added to the system at the time of installation.

The R454B refrigerant cylinders are provided with a ¼" LH flare connection, therefore a ¼" LH female flare adapter will be required. Connect manifold gauges and hoses following conventional charging procedures. Position the

R454B refrigerant cylinder to deliver liquid refrigerant.

ML13KC1 unit is factory charged with R454B. Refer to unit Charging Label for baseline line set length for factory unit charge and Additional Charge guidelines.

Initiate a call for cooling and allow the refrigerant pressures and temperatures to stabilize. Adjust the charge to using the subcooling method. The unit charging label provides the target Subcooling Values. Record the liquid line temperature. Measure the liquid line pressure and use the value to determine the Saturated Liquid Temperature. Calculate subcooling by subtracting the liquid line temperature from the Saturated liquid temperature.

Subcooling = Saturated Liquid Temperature – Liquid Line Temperature

Compare the results with the unit charging label.

Once system charging has been completed, the additional charge and total charge must be marked on the unit nameplate. Total Charge = Factory Charge + Additional charge. The total charge is marked on the space adjacent to "Total Charge". See nameplate below.

Detailed information is given in the ML13KC1 Installation and Service Procedures manual, which is available on LennoxPros.com.

[ ]		[ ]	
M/N [ ]		S/N [ ]	
S/N [ ]		MFG: Month/Year [ ]	
CONTAINS R-454B	MAXIMUM ALLOWABLE PRESSURE		
FACTORY CHARGE	640 PSIG (4412.8 kPa)		
xx LBS xx OZS (X.X kg)	[ ]		
TOTAL CHARGE	[ ]		
ELECTRICAL RATING		NOMINAL VOLTS 208/230	
1 PH	60 HZ	MIN 197	MAX 253

Additional Charge added to bring system to full charge (Line Set Length / Coil matches)

Total System Charge (Factory Charge + Additional Charge)

(NOTE - The nameplate is shown for illustration purposes only. Go to actual nameplate on outdoor unit for charge information.)

## Start Up Test Procedure

The RDS Blower Control Board is equipped with a Test/Reset button, see "Test Button Functionality" on page 12. After the RDS Blower Control Board has been mounted and wired, restore power to the HVAC system. The system will then run through a purge sequence for five (5) minutes. After the purge sequence is complete, proceed to testing cooling demand and heating demand.

### Cooling Demand

- 1 - Prompt a cooling demand at the thermostat.
- 2 - Press the Test button on the RDS Blower Control Board.

The system then executes a leak detection response.

- 3 - Observe the following sequence:
  - a. The LED indicator flashes the sequence for leak detection (flashing blue).

- b. The blower powers up.
- c. The outdoor compressor powers down.

- 4 - Press the Test button to terminate the simulated Leak Detected mode upon test completion.

### Heating Demand

- 1 - Prompt a heating demand at the thermostat.
- 2 - Press the Test button on the RDS Blower Control Board.

The system then executes a leak detection response.

- 3 - Observe the following sequence:
  - a. The LED indicator flashes the sequence for leak detection (flashing blue).
  - b. The blower powers up.
  - c. The outdoor compressor powers down.
- 4 - Press the Test button to terminate the simulated Leak Detected mode upon test completion.

## ADDING OR REMOVING REFRIGERANT

This system uses R-454B which operates at slightly lower pressures than HFC-410A. The pre-installed liquid line filter drier is approved for use with R-454B. Do not replace it with components designed for use with HCFC-22. Check airflow using the Delta-T (DT) process using the illustration in figure 21.

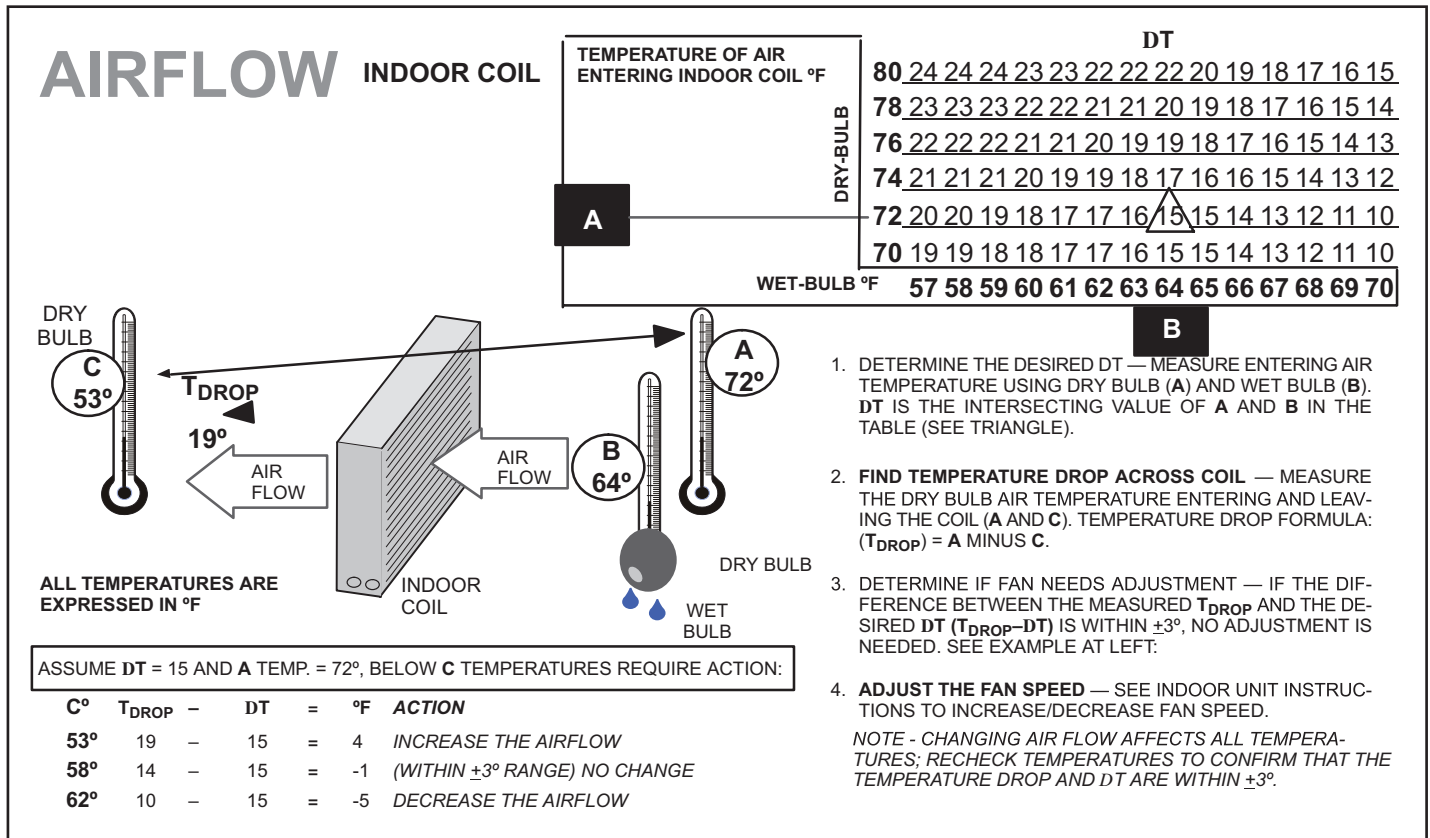

FIGURE 21. Checking Indoor Airflow over Evaporator Coil using Delta-T Chart

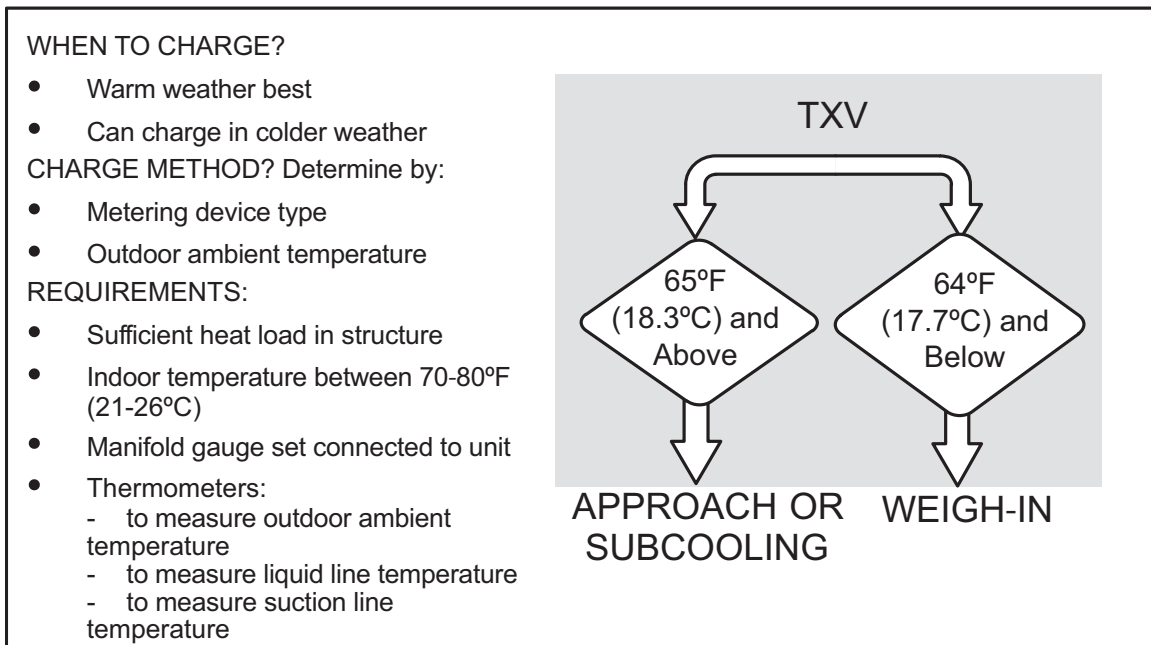

FIGURE 22. Determining Charge Method

# WEIGH IN (RFC AND TXV)

# CALCULATING SYSTEM CHARGE FOR OUTDOOR UNIT VOID OF CHARGE

If the system is void of refrigerant, first, locate and repair any leaks and then weigh in the refrigerant charge into the unit. To calculate the total refrigerant charge:

$$\text{Amount specified on nameplate} + \text{Adjust amount for variation in line set length listed on line set length table below} = \text{Total charge}$$

NOTE — The above nameplate is for illustration purposes only. Go to actual nameplate on outdoor unit for charge information.



Refrigerant Charge per Line Set Length	
Liquid Line Set Diameter	Ounces per 5 feet (g per 1.5 m) adjust from 15 feet (4.6 m) line set*
3/8" (9.5 mm)	3 ounce per 5' (85 g per 1.5 m)

NOTE — Insulate liquid line when it is routed through areas where the surrounding ambient temperature could become higher than the temperature of the liquid line or when pressure drop is equal to or greater than 20 psig.

FIGURE 23. Using R-454B Weigh-In Method

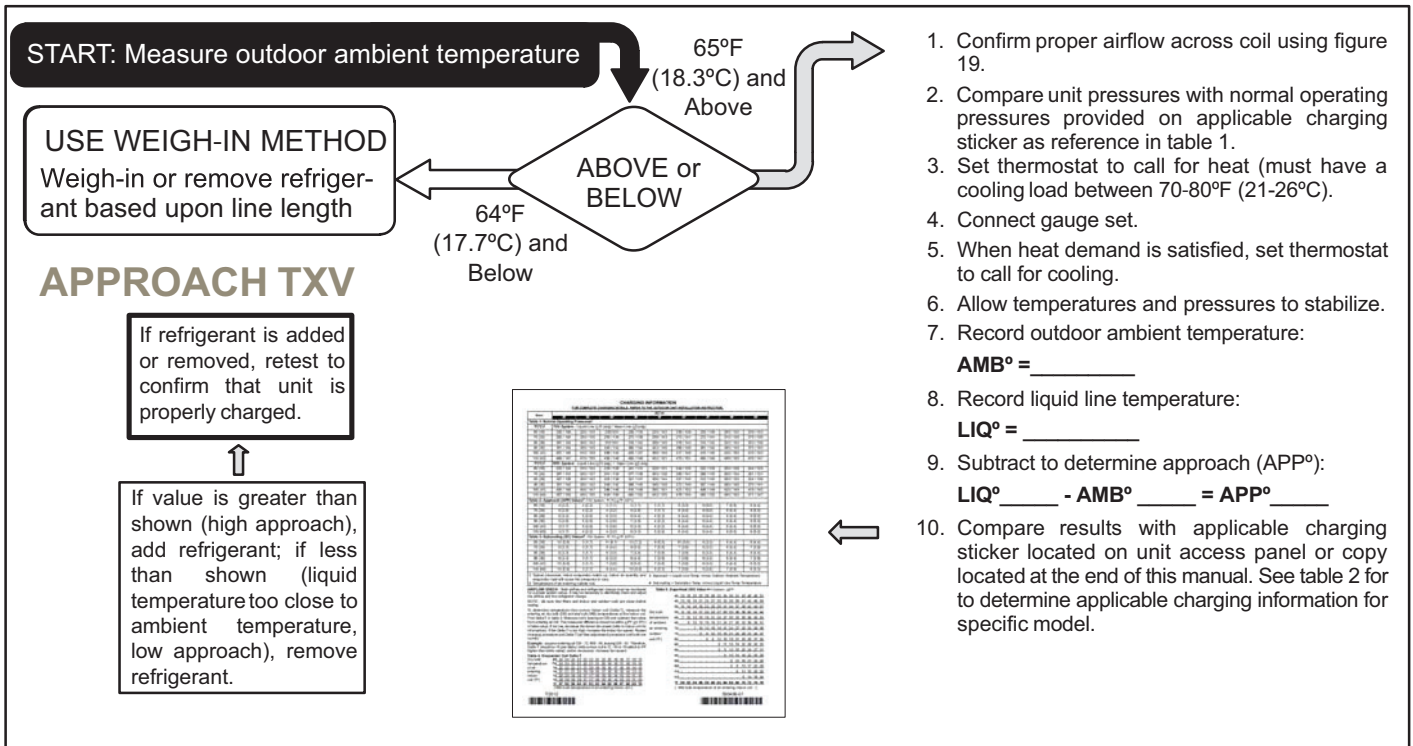
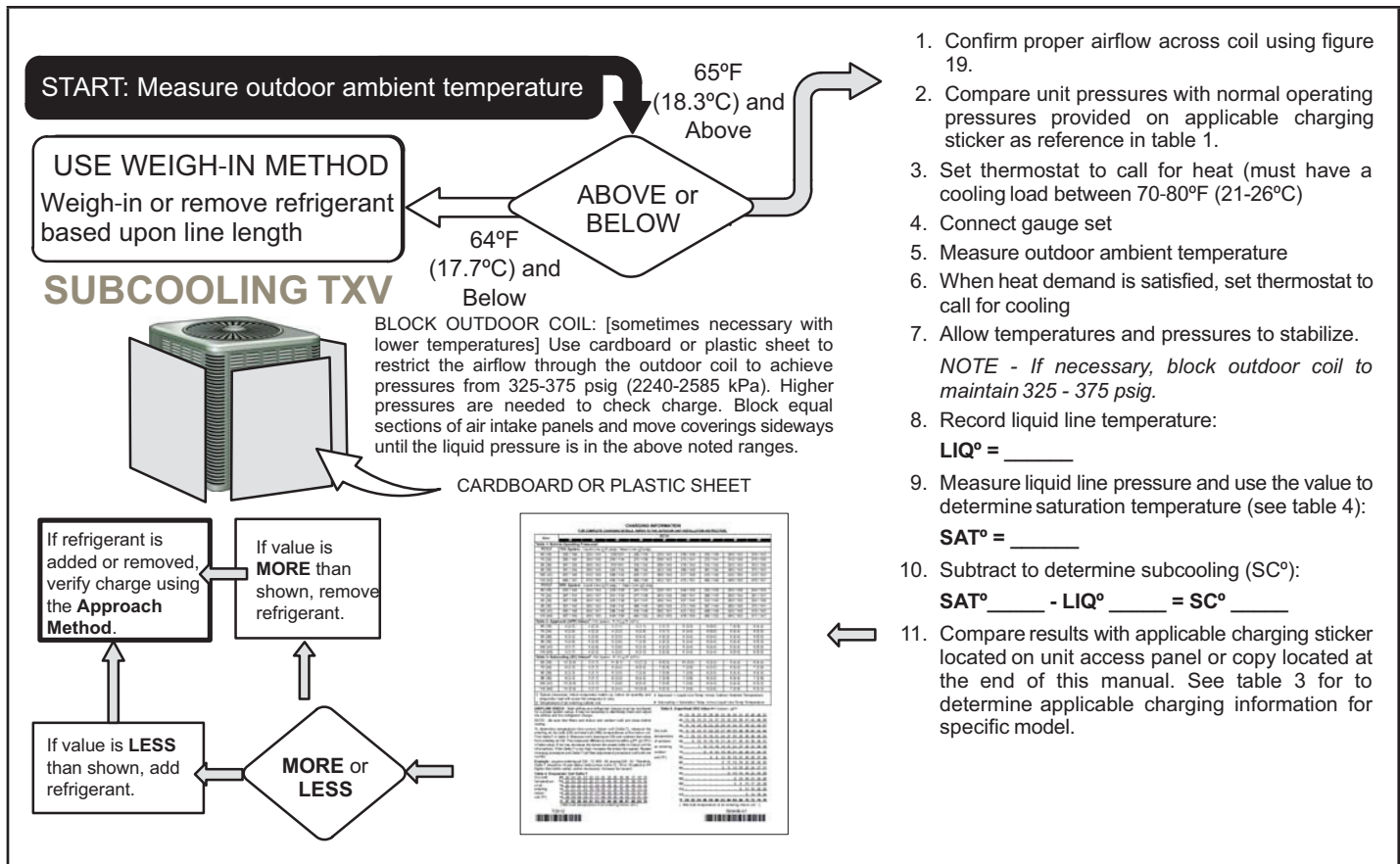

FIGURE 24. R-454B Approach TXV Charge



**FIGURE 25. R-454B Subcooling TXV Charge**

**TABLE 4. R454B Temperature (°F) - Pressure (Psig)**

Pressure (psig)	Saturated Liquid Temp (F°)	Saturated Vapor Temp (F°)	Pressure (psig)	Saturated Liquid Temp (F°)	Saturated Vapor Temp (F°)	Pressure (psig)	Saturated Liquid Temp (F°)	Saturated Vapor Temp (F°)	Pressure (psig)	Saturated Liquid Temp (F°)	Saturated Vapor Temp (F°)
0	-58.9	-57.1	158	58.9	61.3	272	93.0	95.4	362	113.4	115.6
25	-19.2	-17.2	160	59.6	62.0	274	93.5	95.9	364	113.8	116.0
30	-13.9	-11.8	165	61.4	63.8	276	94.0	96.4	366	114.2	116.4
35	-9.0	-6.9	170	63.1	65.5	278	94.5	96.9	368	114.6	116.8
40	-4.4	-2.3	175	64.9	67.3	280	95.0	97.4	370	115.0	117.2
45	-0.2	1.9	180	66.6	69.0	282	95.5	97.9	372	115.4	117.6
50	3.7	5.9	185	68.2	70.6	284	96.0	98.4	374	115.8	118.0
55	7.5	9.7	190	69.8	72.2	286	96.5	98.8	376	116.2	118.4
60	11.0	13.2	195	71.4	73.8	288	97.0	99.3	378	116.6	118.8
65	14.4	16.6	200	73.0	75.4	290	97.5	99.8	380	117.0	119.2
70	17.6	19.8	202	73.6	76.0	292	97.9	100.3	382	117.4	119.6
75	20.6	22.9	204	74.2	76.6	294	98.4	100.7	384	117.7	119.9
80	23.6	25.9	206	74.9	77.3	296	98.9	101.2	386	118.1	120.3
85	26.4	28.7	208	75.5	77.9	298	99.4	101.7	388	118.5	120.7
90	29.1	31.4	210	76.1	78.5	300	99.8	102.2	390	118.9	121.1
95	31.7	34.0	212	76.7	79.1	302	100.3	102.6	392	119.3	121.5
100	34.3	36.6	214	77.3	79.7	304	100.8	103.1	394	119.7	121.9
102	35.3	37.6	216	77.9	80.2	306	101.2	103.5	396	120.1	122.2
104	36.2	38.6	218	78.4	80.8	308	101.7	104.0	398	120.5	122.6
106	37.2	39.5	220	79.0	81.4	310	102.1	104.4	400	120.8	123.0
108	38.1	40.5	222	79.6	82.0	312	102.6	104.9	405	121.8	123.9
110	39.1	41.4	224	80.2	82.6	314	103.0	105.4	410	122.7	124.9
112	40.0	42.4	226	80.8	83.1	316	103.5	105.8	415	123.6	125.8
114	40.9	43.3	228	81.3	83.7	318	103.9	106.2	420	124.6	126.7
116	41.8	44.2	230	81.9	84.3	320	104.4	106.7	425	125.5	127.6
118	42.7	45.1	232	82.4	84.8	322	104.8	107.1	430	126.4	128.5
120	43.6	46.0	234	83.0	85.4	324	105.3	107.6	435	127.3	129.4
122	44.5	46.9	236	83.6	86.0	326	105.7	108.0	440	128.2	130.2
124	45.4	47.7	238	84.1	86.5	328	106.2	108.5	445	129.0	131.1
126	46.2	48.6	240	84.7	87.1	330	106.6	108.9	450	129.9	132.0
128	47.1	49.4	242	85.2	87.6	332	107.0	109.3	460	131.6	133.7
130	47.9	50.3	244	85.8	88.1	334	107.5	109.7	470	133.3	135.3
132	48.8	51.1	246	86.3	88.7	336	107.9	110.2	480	135.0	137.0
134	49.6	51.9	248	86.8	89.2	338	108.3	110.6	490	136.7	138.6
136	50.4	52.8	250	87.4	89.7	340	108.8	111.0	500	138.3	140.2
138	51.2	53.6	252	87.9	90.3	342	109.2	111.5	510	139.9	141.8
140	52.0	54.4	254	88.4	90.8	344	109.6	111.9	520	141.5	143.3
142	52.8	55.2	256	88.9	91.3	346	110.0	112.3	530	143.0	144.8
144	53.6	56.0	258	89.5	91.8	348	110.5	112.7	540	144.5	146.3
146	54.3	56.7	260	90.0	92.4	350	110.9	113.1	550	146.1	147.8
148	55.1	57.5	262	90.5	92.9	352	111.3	113.5	560	147.5	149.2
150	55.9	58.3	264	91.0	93.4	354	111.7	114.0	570	149.0	150.7
152	56.6	59.0	266	91.5	93.9	356	112.1	114.4	580	150.5	152.1
154	57.4	59.8	268	92.0	94.4	358	112.5	114.8	590	151.9	153.5
156	58.1	60.5	270	92.5	94.9	360	112.9	115.2	600	153.3	154.8

**NOTES**

1. R-454B is a zeotropic blend and must be charged with liquid refrigerant only.
2. Saturated liquid temperature is used to calculate liquid subcooling.
3. Saturated vapor temperature is used to calculate suction superheat.
4. See unit charging label for subcooling and additional charging information.

## ML13KC1 Charging Procedures

### AIR CONDITIONER CHARGING INFORMATION

**FOR COMPLETE CHARGING PROCEDURES, REFER TO THE APPLICABLE INSTALLATION AND SERVICE MANUAL AVAILABLE ONLINE**

Capacity	-018	-024	-030	-036	-042	-048	-060
<b>Table 1. Normal Operating Pressures<sup>1</sup></b>							
<b>°F(°C)<sup>2</sup></b>	<b>TXV System – Liquid Line ( ± 10 psig) / Suction Line ( ± 5 psig)</b>						
65 (18)	220 / 131	221 / 131	218 / 121	233 / 123	236 / 126	229 / 127	235 / 124
75 (24)	253 / 134	254 / 133	250 / 126	258 / 129	271 / 132	267 / 134	277 / 126
85 (29)	295 / 136	298 / 134	289 / 131	301 / 132	313 / 135	312 / 136	321 / 129
95 (35)	341 / 138	346 / 136	335 / 135	348 / 134	366 / 135	361 / 138	372 / 131
105 (41)	390 / 140	398 / 138	385 / 136	401 / 136	425 / 134	413 / 141	423 / 133
115 (45)	446 / 141	455 / 140	443 / 137	458 / 139	489 / 135	470 / 142	480 / 136

<b>Table 2. Approach (APP) Values<sup>3</sup> – °F(°C) ± 1°F (0.5°C)</b>							
65 (18)	6 (3.3)	8 (4.4)	2 (1.1)	2 (1.1)	5 (2.8)	2 (1.1)	7 (3.9)
75 (24)	10 (5.6)	11 (6.1)	5 (2.8)	3 (1.7)	7 (3.9)	6 (3.3)	8 (4.4)
85 (29)	9 (5)	10 (5.6)	6 (3.3)	4 (2.2)	7 (3.9)	6 (3.3)	8 (4.4)
95 (35)	7 (3.9)	9 (5)	6 (3.3)	4 (2.2)	6 (3.3)	6 (3.3)	8 (4.4)
105 (41)	7 (3.9)	7 (3.9)	5 (2.8)	4 (2.2)	5 (2.8)	6 (3.3)	8 (4.4)
115 (45)	5 (2.8)	6 (3.3)	5 (2.8)	3 (1.7)	5 (2.8)	5 (2.8)	8 (4.4)

<b>Table 3. Subcooling (SC) Values<sup>4</sup> -TXV System - °F (°C) ± 1°F (0.5°C)</b>							
65 (18)	8 (4.4)	6 (3.3)	11 (6.1)	13 (7.2)	14 (7.8)	14 (7.8)	11 (6.1)
75 (24)	3 (1.7)	3 (1.7)	8 (4.4)	11 (6.1)	11 (6.1)	11 (6.1)	11 (6.1)
85 (29)	4 (2.2)	5 (2.8)	6 (3.3)	11 (6.1)	11 (6.1)	12 (6.7)	11 (6.1)
95 (35)	7 (3.9)	6 (3.3)	6 (3.3)	12 (6.7)	13 (7.2)	12 (6.7)	12 (6.7)
105 (41)	7 (3.9)	8 (4.4)	8 (4.4)	12 (6.7)	16 (8.9)	13 (7.2)	12 (6.7)
115 (45)	9 (5)	10 (5.6)	9 (5)	13 (7.2)	17 (9.4)	13 (7.2)	12 (6.7)

<sup>1</sup> Typical pressures; indoor evaporator match-up, indoor air quantity and evaporator load will cause the pressures to vary.

<sup>2</sup> Temperature of air entering outside coil.

The unit is factory-charged with R454B refrigerant in the amount indicated on the unit rating plate. This charge is based on a matching indoor coil and outdoor coil using a 30 foot (9.1 m) line set. On line sets with 3/8" (9.5mm) liquid line, add 3oz. additional refrigerant for every 5ft. longer than 30ft. If line length is less than 30ft., subtract this amount (see Installation Instructions for more details).

**AIRFLOW CHECK** - Both airflow and refrigerant charge must be monitored for proper system set-up. It may be necessary to alternately check and adjust the airflow and the refrigerant charge.

**NOTE** – Be sure that filters and indoor and outdoor coils are clean before testing.

To determine temperature drop across indoor coil (Delta-T), measure the entering air dry bulb (DB) and wet bulb (WB) temperatures at the indoor coil. Find Delta-T in table 4. Measure coil's leaving air DB and subtract that value from entering air DB. The measured difference should be within ±3°F (±1.8°C) of table value; if too low, decrease the indoor fan speed (refer to indoor unit for information). If the Delta-T is too high, increase the indoor fan speed. Repeat charging procedure and Delta-T (air flow adjustment) procedure until both are correct.

<sup>3</sup> Approach = Liquid Line Temperature minus Outdoor Ambient Temperature.

<sup>4</sup> Subcooling = Saturated Liquid Temperature minus Liquid Line Temperature

#### IMPORTANT !

R-454B is a zeotropic blend. Use saturated liquid temperature to calculate liquid subcooling. Charge unit with liquid only.

**Example:** Assume entering air DB - 72, WB - 64, leaving DB - 53. Therefore, Delta-T should be 15 (per table); delta across coil is 72 - 53 or 19 (which is 4°F higher than table value). Action necessary: increase fan speed.

**Table 4. Evaporator Coil Delta-T**

<b>80</b>	<u>24</u> 24 24 23 23 22 22 22 20 19 18 17 16 15
<b>78</b>	23 23 23 22 22 21 21 20 19 18 17 16 15 14
<b>76</b>	<u>22</u> 22 22 21 21 20 19 19 18 17 16 15 14 13
<b>74</b>	21 21 21 20 19 19 18 17 16 16 15 14 13 12
<b>72</b>	<u>20</u> 20 19 18 17 17 16 15 15 14 13 12 11 10
<b>70</b>	19 19 18 18 17 17 16 15 15 14 13 12 11 10
<b>°F</b>	<b>57 58 59 60 61 62 63 64 65 66 67 68 69 70</b>

[ Wet bulb temperature of air entering indoor coil ]

