

KEY LIST		
LOCATION	COMPONENT DESCRIPTION	
AA01,02,03	A55	CONTROL BOARD, MAIN
BB07,CC07	B1	COMPRESSOR 1
GG01,EE06	B3	MOTOR, BLOWER
GG02,DD06	B4	MOTOR, OUTDOOR FAN 1
HH06	B10	MOTOR, EXHAUST FAN 1
CC08	C5	CAPACITOR, COMPRESSOR
CC08	C7	CAPACITOR, COMPRESSOR HARD START
FF05	F10	FUSE, SCCR RELAY
BB07	HR1	HEATER, COMPRESSOR 1
BB04,05,06	K1	CONTACTOR, COMPRESSOR 1
DD08	K31	RELAY, HARD START KIT
HH04,05	K65	RELAY, EXHAUST FAN 1
BB04,06	K191	RELAY, CRANKCASE HEATER 1
FF04	L1	VALVE, REVERSING 1
CC04	L34	VALVE, SOLENOID, 2 STG COMPRESSOR
EE01	RT6	SENSOR, A55 DISCHARGE (IMC)
CC01	RT17	SENSOR, OUTSIDE AIR TEMP
EE02	RT46	SENSOR, SAT. SUCT TEMP., COMP 1
CC02	RT48	SENSOR, SAT. LIQUID TEMP., COMP 1
AA01	S4	LIMIT, HI PRESS. SWITCH, COMP 1
AA01	S87	SWITCH, LOW PRESS., COMP 1
DD04	T1	TRANSFORMER, CONTROL
EE04	T43	TRANSFORMER, REHEAT

NOTES	
1	RT6 REMOTE MOUNT WIRING
2	MOVE WIRES FROM 240 TO 208 TAP ON TRANSFORMER FOR 208 VOLT APPLICATIONS
3	P-VOLT UNITS - CONNECT T43-C TO K1-L2
4	FOR MODULATING GAS HEAT UNIT ONLY, REFER TO RT6 AS SHOWN IN THE HEATING WIRING DIAGRAM (A-SECTION)

Model: LDT, LHT 024H - 060H P, Y VOLT HEATPUMP - ECM BLOWER WITH HIGHER SCCR
 Voltage: 208-240V/1~/60Hz(P), 208-240V/3~/60Hz(Y)
 Supersedes: N/A Form No: 538195-01 Rev: 4

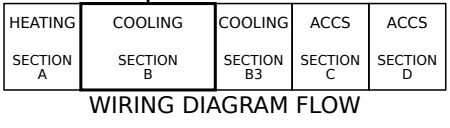

← DENOTES OPTIONAL COMPONENTS AND WIRING

WARNING
 DISCONNECT ALL POWER BEFORE SERVICING.
 ELECTRIC SHOCK HAZARD, CAN CAUSE INJURY OR DEATH. UNIT MUST BE GROUNDED IN ACCORDANCE WITH NATIONAL AND LOCAL CODES.
 FOR USE WITH COPPER CONDUCTORS ONLY. REFER TO UNIT RATING PLATE FOR MINIMUM CIRCUIT AMPACITY AND MAXIMUM OVERCURRENT PROTECTION SIZE.
 IF ANY WIRE IN THIS APPLIANCE IS REPLACED, IT MUST BE REPLACED WITH WIRE OF LIKE SIZE, RATING AND INSULATION THICKNESS.

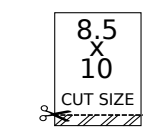

REV	EC NO.	DATE	BY	APVD	REVISION NOTE
--	CN-008852	06/01/2022	AXL	AAH	ORIGINATED AT PD&R CARROLLTON, TX
003	CN-014014F	1/6/2026	ZN	AWH	A) CLEANED UP WIRES TO GAS SECTION (A-SECT)
004	CN-013731A	3/3/2026	ZN	HMT	A) ADDED NOTE 4 FOR MODULATING GAS HEAT



538195-01

02

03

04

05

06

07

08

09

10

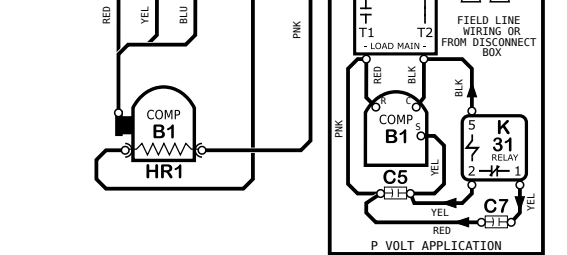
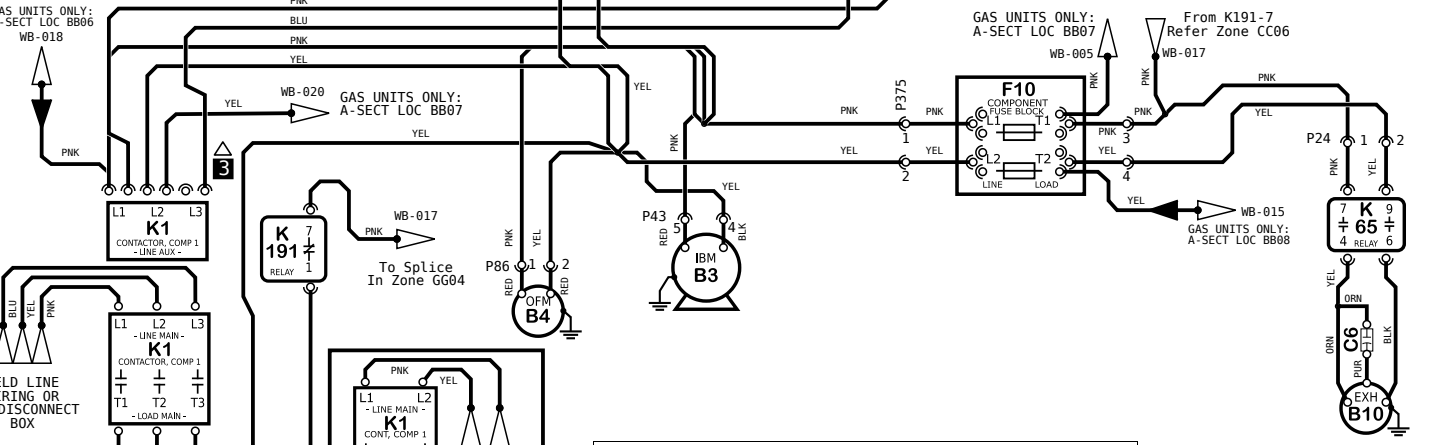
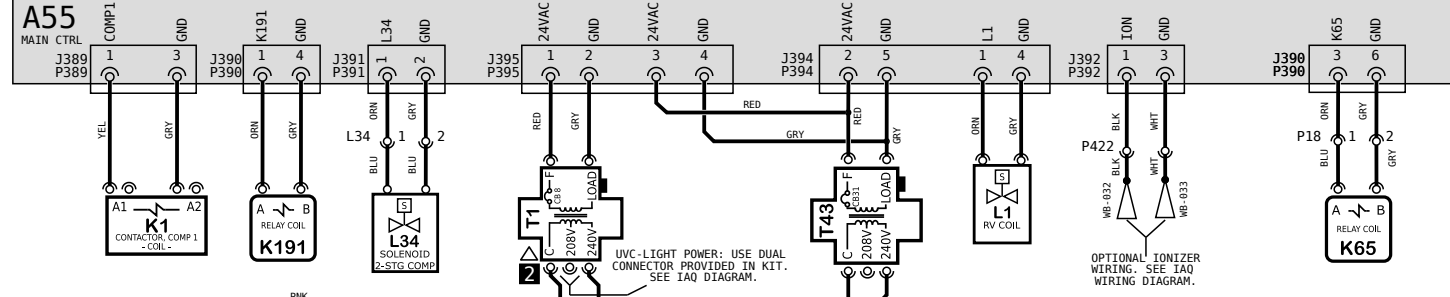
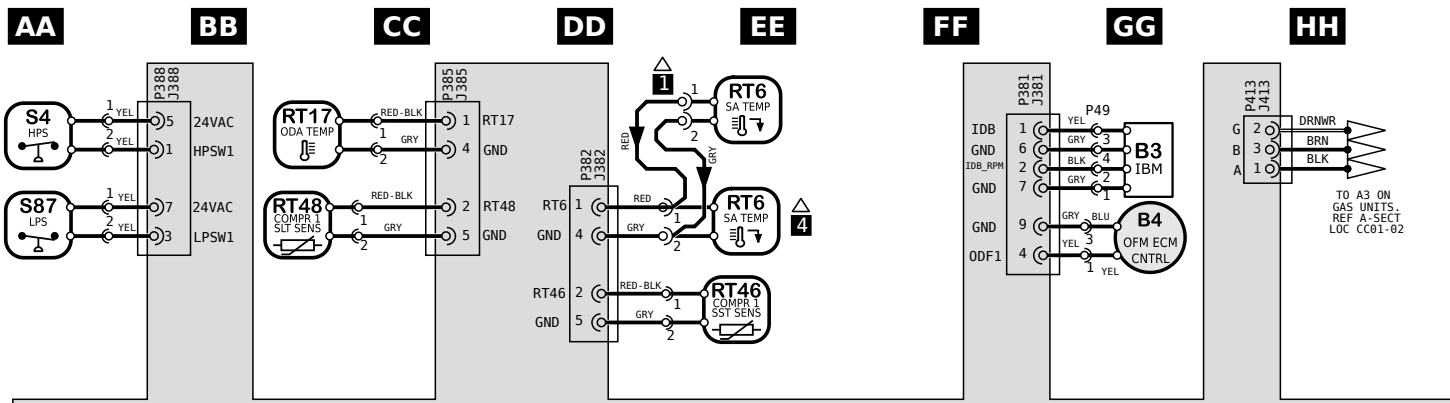

KEY LIST		
LOCATION	COMPONENT DESCRIPTION	
AA01,02,03	A55	CONTROL BOARD, MAIN
BB07,CC07	B1	COMPRESSOR 1
GG01,EE06	B3	MOTOR, BLOWER
GG02,DD06	B4	MOTOR, OUTDOOR FAN 1
HH06	B10	MOTOR, EXHAUST FAN 1
CC08	C5	CAPACITOR, COMPRESSOR
HH08	C6	CAPACITOR, EXHAUST FAN 1
CC08	C7	CAPACITOR, COMPRESSOR HARD START
FF05	F10	FUSE, SCCR RELAY
BB07	HR1	HEATER, COMPRESSOR 1
BB04,05,06	K1	CONTACTOR, COMPRESSOR 1
DD08	K31	RELAY, HARD START KIT
HH04,05	K65	RELAY, EXHAUST FAN 1
BB04,06	K191	RELAY, CRANKCASE HEATER 1
FF04	L1	VALVE, REVERSING 1
CC04	L34	VALVE, SOLENOID, 2 STG COMPRESSOR
EE01	RT6	SENSOR, A55 DISCHARGE (IMC)
CC01	RT17	SENSOR, OUTSIDE AIR TEMP
EE02	RT46	SENSOR, SAT. SUCT TEMP., COMP 1
CC02	RT48	SENSOR, SAT. LIQUID TEMP., COMP 1
AA01	S4	LIMIT, HI PRESS. SWITCH, COMP 1
AA01	S87	SWITCH, LOW PRESS., COMP 1
DD04	T1	TRANSFORMER, CONTROL
EE04	T43	TRANSFORMER, REHEAT

NOTES	
1	RT6 REMOTE MOUNT WIRING
2	MOVE WIRES FROM 240 TO 208 TAP ON TRANSFORMER FOR 208 VOLT APPLICATIONS
3	P-VOLT UNITS - CONNECT T43-C TO K1-L2
4	FOR MODULATING GAS HEAT UNIT ONLY, REFER TO RT6 AS SHOWN IN THE HEATING WIRING DIAGRAM (A-SECTION)

← DENOTES OPTIONAL COMPONENTS AND WIRING

WARNING
DISCONNECT ALL POWER BEFORE SERVICING.
ELECTRIC SHOCK HAZARD, CAN CAUSE INJURY OR DEATH. UNIT MUST BE GROUNDED IN ACCORDANCE WITH NATIONAL AND LOCAL CODES.
FOR USE WITH COPPER CONDUCTORS ONLY. REFER TO UNIT RATING PLATE FOR MINIMUM CIRCUIT AMPACITY AND MAXIMUM OVERCURRENT PROTECTION SIZE.
IF ANY WIRE IN THIS APPLIANCE IS REPLACED, IT MUST BE REPLACED WITH WIRE OF LIKE SIZE, RATING AND INSULATION THICKNESS.

Model: LDT, LHT 024H - 060H P, Y VOLT HEATPUMP - ECM BLOWER WITH HIGHER SCCR
Voltage: 208-240V/1~/60Hz(P), 208-240V/3~/60Hz(Y)
Supersedes: N/A Form No: 538195-01 Rev: 4

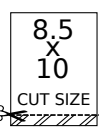
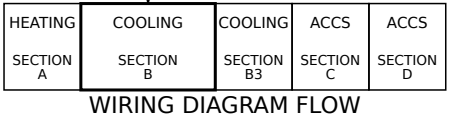

REV	EC NO.	DATE	BY	APVD	REVISION NOTE
--	CN-008852	06/01/2022	AXL	AAH	ORIGINATED AT PD&R CARROLLTON, TX
003	CN-014014F	1/6/2026	ZN	AWH	A) CLEANED UP WIRES TO GAS SECTION (A-SECT)
004	CN-013731A	3/3/2026	ZN	HMT	A) ADDED NOTE 4 FOR MODULATING GAS HEAT