

ZGD

RAIDER® ROOFTOP UNITS

Standard Efficiency | Environ™ Coil | **R-454B** | 60Hz



COMMERCIAL PRODUCT SPECIFICATIONS (EHB)

7.5 to 12.5 Tons

Net Cooling Capacity – 88,000 to 136,000 Btuh

Gas Input Heat Capacity – 130,000 to 240,000 Btuh

RAIDER



MODEL NUMBER IDENTIFICATION

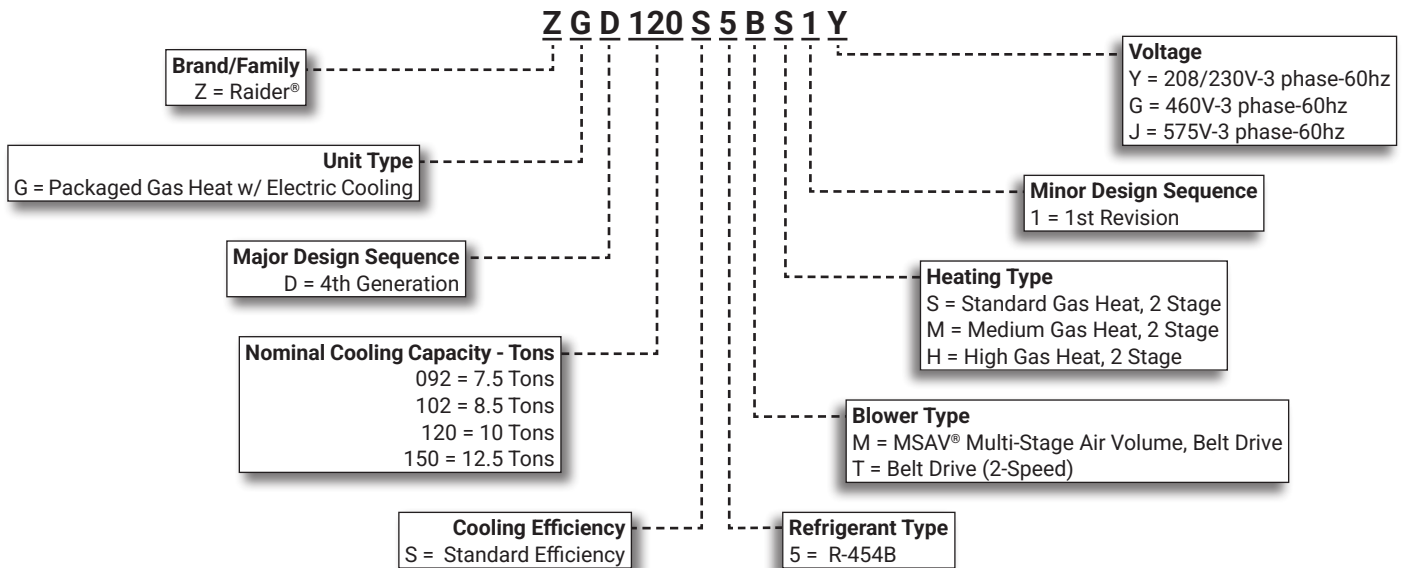

FEATURE HIGHLIGHTS

Raider® rooftop units from Lennox Commercial are the new standard for cost efficient reliable, efficient rooftop units built for long-lasting performance that can significantly improve indoor environments.

1. Aluminized Steel Heat Exchanger
2. Scroll Compressors
3. Environ™ Coil System
4. Outdoor Coil Fans
5. Heavy Gauge Steel Cabinet
6. Smoke Detector (option)
(Supply and Return)
7. MSAV® Multi-Stage Air Volume Blower
8. Disconnect Switch (option)
9. GFI Service Outlet (option)

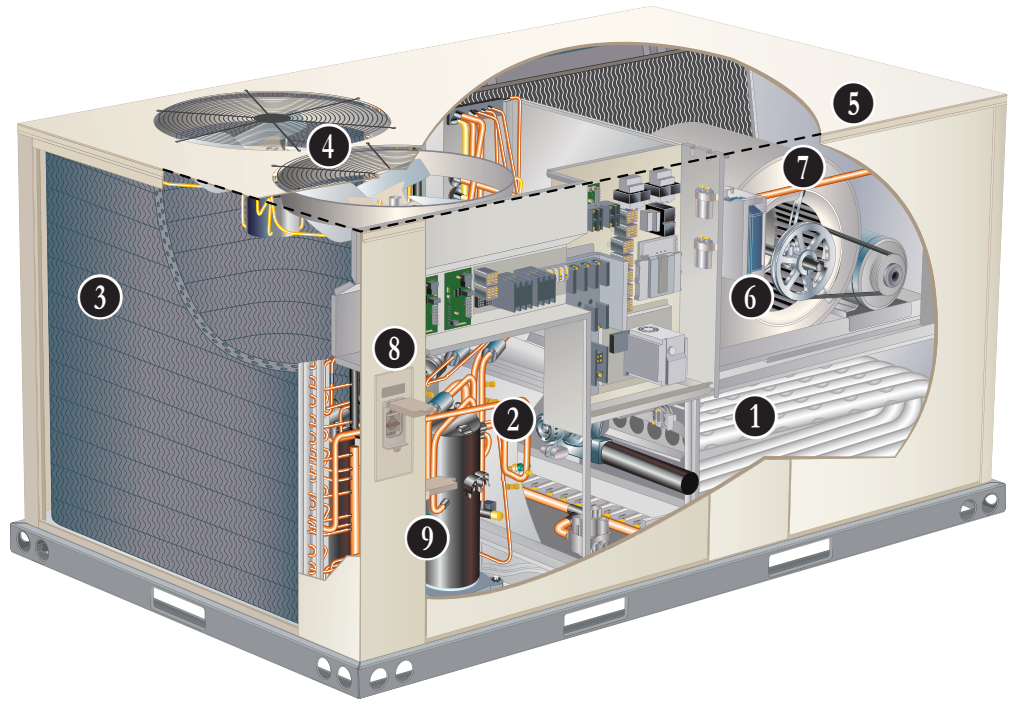

CONTENTS

Approvals And Warranty	3
Blower Data	22
Dimensions	29
- Accessories	30
- Unit	29
Electrical Data	25
- 7.5 Ton	25
- 8.5 Ton	25
- 10 Ton	26
- 12.5 Ton	26
Features And Benefits	3
High Altitude Derate	17
Model Number Identification.	1
Optional Conventional Temperature Control Systems.	11
Options / Accessories	13
Outdoor Sound Data	27
Ratings	18
Specifications	16
- Gas Heat	17
- Unit	16
Unit Clearances	27
Weight Data	28

APPROVALS AND WARRANTY

APPROVALS

- All models are AHRI Standard 340/360-2022 certified
- ETL listed
- All models are ASHRAE 90.1-2025 compliant
- All models meet DOE 2023 energy efficiency standards
- All models are listed to UL 60335-1 and UL 60335-2-40 and meet the Refrigerant Detection and Dissipation Requirements
- Components are bonded for grounding to meet safety standards for servicing required by ETL, NEC and CEC
- All models meet California Code of Regulations, Title 24 and ASHRAE 90.1-2025 Section 6.4.3.10 requirements for staged airflow
- All models have been sound tested in accordance with test conditions included in AHRI Standard 270 or 370
- All models have FSA approval and are compliant with standard ASCE 7-22 (ASD) and the Florida Building Code Eighth Edition (2023)
- Units are charged with virgin refrigerant to comply with NYCRR Part 494
- All models are fully charged and run tested to verify unit operation and functionality

WARRANTY

- Aluminized Heat Exchanger - Limited ten years
- Stainless Steel Heat Exchanger (optional) - Limited fifteen years
- Compressors - Limited five years
- Environ™ Coil System - Limited three years
- Variable-Frequency Drive (VFD) - Limited five years
- High Performance Economizers (optional) - Limited five years
- All other covered components - Limited one year

FEATURES AND BENEFITS

HEATING SYSTEM

- Aluminized steel inshot burners
- Direct spark ignition
- Electronic flame sensor
- Combustion air inducer
- Redundant automatic dual stage gas valve with manual shut-off

1 Heat Exchanger

- Tubular construction, aluminized steel
- Life-cycle tested

NOTE - Optional Stainless Steel Heat Exchanger is required if mixed air temperature is below 45°F.

Electronic Pilot Ignition

- Electronic spark igniter provides positive direct ignition of burners on each operating cycle
- Permits main gas valve to stay open only when the burners are proven to be lit
- If loss of flame occurs, gas valve closes, shutting off the gas to the burners
- LED indicates status and aids in troubleshooting
- Watchguard circuit on module automatically resets ignition controls after one hour of continuous thermostat demand after unit lockout, eliminating nuisance service calls
- Factory installed in the gas heating compartment

Safety Switches

- Flame roll-out switch
- Flame sensor
- Combustion air inducer proving switch
- Protects system operation

Limit Controls

- Redundant limit controls with fixed temperature setting
- Protects heat exchanger and other components from overheating

Required Selections

Gas Input Choice - Order one:

- Standard Gas Heat, 2 Stage (85,000/130,000 Btuh)
- Medium Gas Heat, 2 Stage (117,000/180,000 Btuh)
- High Gas Heat, 2 Stage (156,000/240,000 Btuh)

FEATURES AND BENEFITS

HEATING SYSTEM (continued)

Options/Accessories

Factory Installed

Stainless Steel Heat Exchanger

- Required if mixed air temperature is below 45°F

Field Installed

LPG/Propane Kits

- Conversion kit to field change over units from Natural Gas to LPG/Propane

Combustion Air Intake Extensions

- Recommended for use with existing flue extension kits in areas where high snow areas can block intake air

Vertical Vent Extension Kit

- Use to exhaust flue gases vertically above unit
- Required when unit vent is too close to fresh air intakes per building codes
- Also prevents ice formation on intake louvers
- Kit contains vent transition, vent tee, drain cap, and installation hardware

NOTE - Straight vent pipes (4 in. B-Vent) and caps are not furnished and must be field supplied. Refer to kit instructions for additional information.

COOLING SYSTEM

- Designed to maximize sensible and latent cooling performance at design conditions
- System can operate from 40°F to 125°F without any additional controls

R-454B Refrigerant

- Low GWP (Global Warming Potential)
- Zero ODP (Ozone Depletion Potential)
- Low Toxicity/Lower Flammability - A2L
- Unit is factory pre-charged

2 Scroll Compressors

- System consists of one two-stage scroll compressor and one single-stage scroll compressor
- Resiliently mounted on rubber grommets for quiet operation

Thermal Expansion Valves

- Circuit 1 - Two-stage (all models)
- Circuit 2 - Single-stage (150 model)
- Ensures optimal performance throughout the application range
- Removable element head

Refrigerant Metering Orifice

- Circuit 2 - Single-stage (092, 102, 120 models)
- Accurately meters refrigerant in system
- Refrigerant control is accomplished by exact sizing of refrigerant metering orifice

Filter/Driers

- High capacity filter/drier protects the system from dirt and moisture

High Pressure Switches

- Protects the compressor from overload conditions such as dirty condenser coils, blocked refrigerant flow or loss of outdoor fan operation

Low Pressure Switches

- Protects the compressor from low pressure conditions such as low refrigerant charge or low/no airflow

3 Condenser Coil - Environ™ Coil System

- Condenser and evaporator coil
- Lightweight, all aluminum brazed fin construction
- Constructed of three components:
 - A flat extrusion tube
 - Fins in-between the flat extrusion tube
 - Two refrigerant manifolds

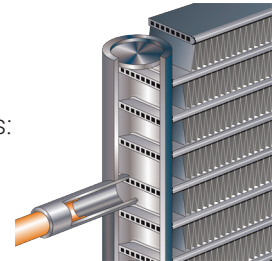

Environ™ Coil System Features:

- Improved heat transfer performance due to high primary surface area (flat tubes) versus secondary surface (fins)
- Smaller internal volume (reduced refrigerant charge)
- High durability
- All aluminum construction
- Fewer brazed joints
- Compact design
- Reduced unit weight
- Easy maintenance/cleaning
- Mounting brackets with rubber inserts secure coil to unit providing vibration dampening and corrosion protection

Antimicrobial Condensate Drain Pan

- Composite pan, sloped to meet drainage requirements of ASHRAE 62.1
- Antimicrobial additive resists growth of mold and mildew on drain pan, which improves indoor air quality and reduces drain line blockage
- Side drain connections

4 Outdoor Coil Fan Motors

- Thermal overload protected
- Totally enclosed
- Permanently lubricated ball bearings
- Shaft up
- Wire basket mount

Outdoor Coil Fans

- PVC coated fan guard furnished

Required Selections

Cooling Capacity

- Specify nominal cooling capacity

Options/Accessories

Field Installed

Condensate Drain Trap

- Available in copper or PVC

FEATURES AND BENEFITS

COOLING SYSTEM (continued)

Drain Pan Overflow Switch

- Monitors condensate level in drain pan
- Shuts down unit if drain becomes clogged

Low Ambient Kit

(Includes Compressor Crankcase Heater)

- Cycles the outdoor fans while allowing compressor operation in the cooling cycle
- Intermittent fan operation allows the system to operate without icing the evaporator coil and losing capacity
- Designed for use in ambient temperatures no lower than 0°F
- Controls the compressor crankcase heaters

NOTE - Compressor crankcase heater is furnished with the kit and protects against refrigerant migration that can occur during low ambient operation.

LOW GWP REFRIGERANT DETECTION SYSTEM (RDS)

- Complies with UL 60335-2-40 approved standard
- Required for all systems using R-454B refrigerant
- Factory installed on all units
- Consists of a refrigerant detection sensor(s) and a mitigation control
- Ensures safe operation for systems equipped with R-454B refrigerant
- Sensor(s) monitors indoor coil area for R-454B refrigerant
- If R-454B refrigerant is detected the refrigerant detection system will prevent compressor and heating operation until R-454B refrigerant is no longer detected
- Refrigeration detection system energizes blower if any R-454B refrigerant is detected to mitigate any concentrations of refrigerant from the unit and the system

CABINET

Construction

- 5** • Heavy-gauge steel panels
- Full perimeter heavy-gauge galvanized steel base rail
- Base rails have rigging holes
- Three sides of the base rail have forklift slots
- Raised edges around duct and power entry openings in the bottom of the unit for water protection

Airflow Choice

- Units are shipped in downflow (vertical) return air flow configuration

NOTE - Units can be field converted to horizontal airflow.

Duct Flanges

- Provided for horizontal duct attachment

Power/Gas Entry

- Electrical and gas lines can be routed through the unit base or through horizontal access knock-outs

NOTE - Optional Bottom Power Entry Kit is available.

Exterior Panels

- Constructed of heavy-gauge, galvanized steel
- Textured pre-paint with polyurethane finish
- Cyclic salt fog and UV exposure up to 1,680 hours per ASTM D5894

Insulation

- Fully insulated with non-hygroscopic fiberglass insulation (conditioned areas)

Access Panels

- Filter section
- Blower/heating section
- Compressor/controls section
- Recessed handles for easy service access

Options/Accessories

Field Installed

Combination Coil/Hail Guards

- Heavy gauge steel frame
- Painted to match cabinet
- Expanded metal mesh protects outdoor coil

CONTROLS

Compressor Monitor Control

- Two controls are furnished (one for each refrigeration circuit)
- Anti-short cycle control (5 minutes)
- High and low pressure switch monitoring with five-strike lockout protection
- LEDs for diagnostic and troubleshooting

Refrigerant Detection System (RDS) Control

- Monitors leak detection sensor
- Terminal strip for thermostat, float switch and RDS alarm connections
- LED for power and sensor status

24V Transformer

- For all control voltage
- Resettable pop-up fuse

Options/Accessories

Field Installed

6 Smoke Detector

- Photoelectric type
- Installed in supply air section, return air section or both sections
- Available with power board and single sensor (supply or return) or power board and two sensors (supply and return)
- Power board located in unit blower compartment

Thermostats

- Control system and thermostat options, see page 11.

FEATURES AND BENEFITS

BLOWER

A wide selection of supply air blower options are available to meet a variety of airflow requirements

7 Blower Motor

- Overload protected
- Ball bearings
- Available in several different sizes to maximize air performance.
- Two-speed belt drive motor (low static/high static) is available on 092-102 models

Supply Air Blower

- Forward curved blades
- Double inlet
- Blower wheel statically and dynamically balanced
- Ball bearings
- Adjustable pulley (allows speed change).
- Blower assembly slides out of unit for servicing

MSAV® Multi-Stage Air Volume Operation (092 and 102 Models)

- MSAV® Multi-Stage Air Volume stages the amount of airflow according to compressor stages, heating demand and ventilation demand
- Units utilize a 2-Speed induction blower motor to stage the supply air blower airflow
 - Low Speed - 1st and 2nd Stage cooling and ventilation mode
 - High Speed - 3rd Stage (Full load) cooling and all heat modes
- High speed blower operation is set by adjusting the motor pulley to deliver the desired air volume

NOTE: Ventilation speed is same as low speed for improved energy savings. Lower operating costs are obtained when the blower is operated on lower speeds.

NOTE: Part-load airflow in cooling mode should not be set below 220 cfm/nominal full load ton to reduce the risk of evaporator coil freeze-up.

MSAV® Multi-Stage Air Volume Sequence of Operation (092 and 102 Models)

- Blower operates in low speed with (G) demand
- Blower operates in low speed for mechanical cooling (Y1) or (Y1+Y2)
- Blower operates in high-speed for any other mode: (Y1+Y2+Y3), and heating
- Economizer damper minimum position is fully closed in unoccupied mode
- In occupied mode, the economizer damper minimum position is determined by the economizer minimum position of the potentiometer
- When outdoor air is not suitable the blower operates on low speed for (Y1) or (Y1+Y2) and switches to high-speed for (Y1+Y2+Y3).
- In free cooling, the blower operates on low speed for (Y1) or (Y1+Y2)

NOTE: Economizer position is determined by mixed air sensor when unit is in free cooling.

MSAV Multi-Stage Air Volume Operation (120-150 Models)

- MSAV Multi-Stage Air Volume stages the amount of airflow according to compressor stages, heating demand and ventilation demand
- Units utilize a Variable Frequency Drive (VFD) to stage the supply air blower airflow
- VFD alters the frequency and voltage of the power supply to the blower to control blower speed
- The supply air blower has three speeds:
 1. Low Speed - 1st Stage Cooling
 2. Medium Speed - 2nd Stage Cooling
 3. High Speed - Full load cooling and all heat modes
- Full speed blower operation is set by adjusting the motor pulley to deliver the desired air volume
- Ventilation speed is same as low speed for improved energy savings

NOTE - Part load airflow in cooling mode should not be set below 220 cfm/nominal full load ton to reduce the risk of evaporator coil freeze-up.

• VFD has an operational range of -40 to 125° F outdoor air ambient temperature

NOTE - Lower operating costs are obtained when the blower is operated on lower speeds.

FEATURES AND BENEFITS

BLOWER (Continued)

MSAV Multi-Stage Air Volume Sequence of Operation

- Blower operates in low speed with (G) demand
- Blower operates in low speed for mechanical cooling (Y1)
- Blower operates in medium speed for any other mode (mechanical cooling Y1+Y2)
- Blower operates in high speed for any other mode (mechanical cooling Y1+Y2+Y3, and heating)
- Economizer damper minimum position is fully closed in unoccupied mode
- In occupied mode, the economizer damper minimum position is determined by the economizer minimum position of the potentiometer

NOTE - Variable Frequency Drive (VFD) is designed to operate on balanced, three-phase power. Operating units on unbalanced three-phase power will reduce the reliability of all electrical components in the unit. Unbalanced power is a result of the power delivery system supplied by the local utility company. Factory-installed inverters are sized to drive blower motors with an equivalent current rating using balanced three-phase power. If unbalanced three-phase power is supplied the installer must replace the existing factory-installed inverter with an inverter that has a higher current rating to allow for the imbalance. Refer to the installation instructions for additional information and replacement information.
Required Selections

Required Selections

- Order blower motor horsepower and drive kit number required when base unit is ordered
- See Drive Kit Specifications Table

ELECTRICAL

Marked & Color-Coded Wiring

- All electrical wiring is color-coded and marked to identify which components it is connecting

Electrical Plugs

- Positive connection electrical plugs are used to connect common accessories or maintenance parts for easy removal or installation

Required Selections

Voltage Choice

- Specify when ordering base unit

Factory or Field Installed

8 Disconnect Switch

- Accessible from outside of unit
- Spring loaded weatherproof cover furnished

Field Installed

Bottom Power Entry Kit

- Reduces the number of penetrations in the roof
- Includes bulkhead connectors to provide power and control wiring routing through the roof curb

9 GFI Service Outlets (2)

- 115V ground fault circuit interrupter (GFCI) type
- Field installed, non-powered, field wired
- Waterproof heavy-duty UV-resistant polycarbonate case cover furnished

INDOOR AIR QUALITY

Air Filters

- Disposable 2 inch MERV 4 filters furnished as standard

Options/Accessories

Field Installed

Replacement Filter Media Kit With Frame

- Replaces existing pleated filter media
- Includes washable metal mesh screen and metal frame with clip for holding replaceable non-pleated filter

Indoor Air Quality (CO₂) Sensors

- Reports to the economizer control to adjust the dampers as needed

OPTIONS / ACCESSORIES

ECONOMIZER (continued)

High Performance Economizer Control Module

- Provides inputs and outputs to control economizer based on parameter settings
- Free cooling based on single dry bulb temperature, or combination temperature + humidity sensors
- Automatic switchover for different control modes
- Parameter settings based on climate zone, using GPS functionality in the Climatix Mobile application
- LED indication for free cooling operation, sensor operation and damper operation
- Quick installation and easy commissioning with the **Climatix Mobile App** on a mobile device

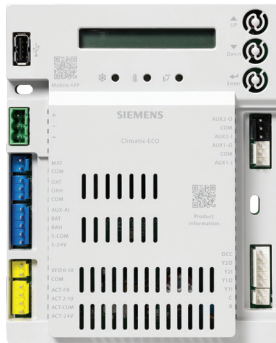

NOTE - WLAN Stick is required for App connection to module(s).

- Module displays any alarm messages (fault detection and diagnostics) as an aid in troubleshooting
- RS585 port for BACnet MSTP or Modbus RTU communication
- USB port for firmware updates and WLAN connection for setup and commissioning
- QR codes on module for quick access to download Climatix Mobile App and user documentation
- User Interface for normal operation, parameter setup and, alarm notifications with an LCD display and three operation buttons:
 1. **Up Button** - Move to the previous value, step or category
 2. **Down Button** - Move to the next value, step or category
 3. **Enter Button** -
 - Press to edit the current value or option
 - Press to confirm a newly selected value or option
 - Press Enter + Up to jump up one category
 - Press Enter + Down to jump down one category

NOTE - The Free Cooling setpoint for Title 24 applications must be set based on the Climate Zone where the system is installed. See Section 140.4 "Prescriptive Requirements for Space Conditioning Systems" of the California Energy Commission's 2013 Building Energy Efficiency Standards.

NOTE - Refer to Installation Instructions for complete setup information and menu parameters available.

Field Installed

Single Enthalpy Temperature Control

- Outdoor air enthalpy sensor enables economizer if the outdoor enthalpy is less than the setpoint of the control

Differential Enthalpy Control (Not for Title 24)

- Order one for factory installed economizer
- Order two for field installed economizer
 - One is field installed in the return air section
 - One in the outdoor air section
- Allows the economizer control board to select between outdoor air or return air, whichever has lower enthalpy

WLAN Stick

- Required for Climatix Mobile App usage
- Plugs into USB port on Module to provide a temporary WLAN connection for setup, commissioning, and servicing

NOTE - Only one WLAN Stick is required and can be used on multiple modules.

EXHAUST

Field Installed

Horizontal Low Profile Barometric Relief Dampers

Power Exhaust Fan

- Installs internal to unit for downflow applications only with Economizer option
- Provides exhaust air pressure relief
- Interlocked to run when supply air blower is operating
- Fan runs when outdoor air dampers are 50% open (adjustable)
- Motor is overload protected
- Fan is 20 in. diameter
- Five fan blades
- One 1/3 HP motor

NOTE - Requires Economizer and Downflow Barometric Relief Dampers.

OPTIONS / ACCESSORIES

OUTDOOR AIR

Field Installed

Outdoor Air Damper

- Downflow or Horizontal
- Linked mechanical dampers
- 0 to 25% (fixed) outdoor air adjustable
- Installs in unit
- Includes outdoor air hood
- Motorized model features fully modulating spring return damper motor with plug-in connection
- Manual model features a slide damper

NOTE - Maximum mixed air temperature in cooling mode is 100°F.

ROOF CURBS

Field Installed

Hybrid Roof Curbs, Downflow

- Nailer strip furnished; mates to unit
- US National Roofing Contractors approved
- Shipped knocked down
- Interlocking tabs fasten corners together
- No tools required for assembly
- Can also be fastened together with furnished hardware
- Available in 8, 14, 18, and 24 inch heights

Adaptor Curbs (not shown)

- Curbs are regionally sourced
- Dimensions will vary based upon the source

NOTE - Contact your local sales representative for a detailed cut sheet with applicable dimensions.

CEILING DIFFUSERS

Field Installed

- Flush or Step-Down
- White powder coat finish on diffuser face and grilles
- Insulated UL listed duct liner
- Diffuser box has collars for duct connection
- Step-down diffusers have double deflection blades
- Flush diffusers have fixed blades
- Provisions for suspending
- Internally sealed to prevent recirculation
- Removable return air grille
- Adapts to T-bar ceiling grids or plaster ceilings

Transitions (Supply and Return)

NOTE - Ceiling Diffuser Transitions are not furnished and must be field fabricated.

OPTIONAL CONVENTIONAL TEMPERATURE CONTROL SYSTEMS

CS7500 Commercial 7-Day Programmable Thermostat



- Premium Universal Thermostat
- Full Color Touchscreen Interface
- Up To 4 Heat / 3 Cool
- Built-In Sensors For Temperature and Humidity
- Remote Sensors Options For Temperature, Discharge Air, Outdoor Air
- 5-2 or 7-Day Scheduling
- Smooth Setback Recovery
- Heat/Cool Auto-Changeover
- FDD, ASHRAE, IECC Compliant

CS3000 Commercial 5-2 Day Programmable Thermostat

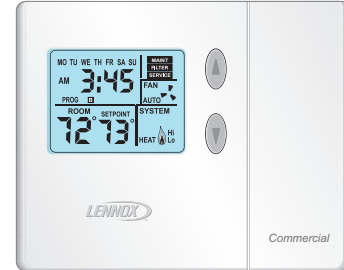

- Conventional Multi-Stage Thermostat
- Intuitive Display
- Push-Button Operation
- Up To 2 Heat / 2 Cool
- Built-In Temperature Sensor
- Remote Temperature Sensing
- Up to 5-2 Day Scheduling
- Smooth Setback Recovery
- Heat/Cool Auto-changeover

Optional Accessories

Cooling Stage-Up Timer Relay

- Allows the unit to attain an additional stage of cooling without the need for extra thermostat connections
- Adjustable - 1 to 1023 seconds
- Mounts internal to unit

OPTIONAL CONVENTIONAL TEMPERATURE CONTROL SYSTEMS

BACnet Compatible Thermostat With Reheat



- 7-Day Programmable
- For units with or without Humiditrol®
- BTL listed MS/TP ensures compatibility with any BACnet system
- Built-in control programs for conventional and heat pump applications
- Conventional systems up to 3-stage heat and 3-stage cool
- Heat pumps with 1 or 2 compressors and up to 2-stage auxiliary heat
- On-board temperature and humidity sensor
- Multiple configurable inputs and outputs enable advanced control strategies
- Set-up Wizard enables rapid system configuration
- No special tools required for installation or commissioning
- Seven-day (2, 4 or 6 event) occupancy scheduling per day
- Backlit 5-inch LCD touchscreen

Description	Order Number	
CS7500 Commercial 7-Day Programmable Thermostat		
CS7500 7-Day Thermostat	24K41	
Sensors/Accessories	¹ Remote non-adjustable wall-mount 20k	47W36
	¹ Remote non-adjustable wall-mount 10k	47W37
	Remote non-adjustable discharge air (duct mount)	19L22
	Outdoor temperature sensor	X2658
CS3000 5-2 Day Programmable Thermostat		
CS3000 5-2 Day Thermostat	11Y05	
Sensor/Accessories	Remote non-adjustable wall mount 10k averaging	47W37
	Thermostat wall mounting plate	X2659
Optional Accessory		
	Cooling Stage-Up Timer Relay	24G40
BACnet 7-Day Programmable Thermostat		
BACnet Controls	² 7-Day BACnet Thermostat	24C57
	³ BACnet Module	16X71
⁴ BACnet Room Sensors	With Display	97W23
	Without Display	97W24
Universal Thermostat Guard with Lock (clear)		
	Inside Dimensions (H x W x D) 5-7/8 x 8-3/8 x 3 in.	39P21

¹ Remote wall-mount sensors can be applied in any of the following combinations:
 One Sensor - (1) 47W36, Two Sensors - (2) 47W37, Three Sensors - (2) 47W36 and (1) 47W37
 Four Sensors - (4) 47W36, Five Sensors - (3) 47W36 and (2) 47W37

² BACnet Thermostat (24C57) will control units with and without the Humiditrol® option. If there is a mix of units equipped with and without Humiditrol on the same site, this thermostat can be used for all units if suitable.

³ Not compatible with units equipped with Humiditrol®dehumidification option.

⁴ Only compatible with BACnet Module (16X71).

OPTIONS / ACCESSORIES

Item Description	Order Number	Size				
		092	102	120	150	
COOLING SYSTEM						
Condensate Drain Trap	PVC	38R23	X	X	X	X
	Copper	38V21	X	X	X	X
Drain Pan Overflow Switch		38A64	X	X	X	X
Low Ambient Kit (Includes Compressor Crankcase Heater)	208/230V-3ph	10Z35	X	X		
	460V-3ph	10Z36	X	X		
	575V-3ph	10Z37	X	X		
	208/230V-3ph	10Z50			X	X
	460V-3ph	10Z51			X	X
	575V-3ph	10Z52			X	X
HEATING SYSTEM						
Combustion Air Intake Extensions		19W51	X	X	X	X
Gas Heat Input	130,000 Btuh	Factory	O	O	O	O
	180,000 Btuh	Factory	O	O	O	O
	240,000 Btuh	Factory	O	O	O	O
LPG/Propane Conversion Kits	Standard Heat	14N22	X	X	X	X
	Medium Heat	14N27	X	X	X	X
	High Heat	14N25	X	X	X	X
Stainless Steel Heat Exchanger		Factory	O	O	O	O
Vertical Vent Extension Kit		31W62	X	X	X	X
BLOWER - SUPPLY AIR						
Blower Motors	Two-Speed Belt Drive - 2 HP	Factory	O	O		
	MSAV® Belt Drive - 3 HP	Factory			O	
	MSAV® Belt Drive - 5 HP	Factory				O
Drive Kits See Blower Data Tables for selection	Kit #1 590-890 rpm	Factory	O	O		
	Kit #2 800-1105 rpm	Factory	O	O		
	Kit #3 795-1195 rpm	Factory	O	O		
	Kit #4 730-970 rpm	Factory			O	
	Kit #5 940-1200 rpm	Factory			O	
	Kit #6 1015-1300 rpm	Factory			O	
	Kit #10 900-1135 rpm	Factory				O
	Kit #11 1040-1315 rpm	Factory				O
CABINET						
Combination Coil/Hail Guards		12X21	X	X	X	X
CONTROLS						
Smoke Detector - Supply or Return (Power board and one sensor)		39U76	X	X	X	X
Smoke Detector - Supply and Return (Power board and two sensors)		39U75	X	X	X	X

NOTE - See Conventional Thermostat Control Systems on page 11 for Additional Options.

NOTE - Order numbers shown are for ordering field installed accessories.

OX - Configure To Order (Factory Installed) or Field Installed

O = Configure To Order (Factory Installed)

X = Field Installed

OPTIONS / ACCESSORIES

Item Description	Order Number	Size				
		092	102	120	150	
ELECTRICAL						
Voltage 60 hz	208/230V - 3 phase	Factory	O	O	O	O
	460V - 3 phase	Factory	O	O	O	O
	575V - 3 phase	Factory	O	O	O	O
Bottom Power Entry Kit		11H66	X	X	X	X
Disconnect	See Electrical/Electric Heat Tables for selection		OX	OX	OX	OX
GFI Service Outlets with Cover	15 amp non-powered, field-wired (208/230V, 460V only)	39U74	X	X	X	X
	¹ 20 amp non-powered, field-wired (208/230V, 460V, 575V)	39U77	X	X	X	X
INDOOR AIR QUALITY						
Air Filters						
Replacement Media Filter With Metal Mesh Frame (includes non-pleated filter media)		Y3063	X	X	X	X
Indoor Air Quality (CO₂) Sensors						
Sensor - Wall-mount, off-white plastic cover with LCD display		77N39	X	X	X	X
Sensor - Wall-mount, black plastic case, no display, rated for plenum mounting		87N54	X	X	X	X
CO ₂ Sensor Duct Mounting Kit - for downflow applications		23Y47	X	X	X	X
Aspiration Box - for duct mounting non-plenum rated CO ₂ sensors (77N39)		90N43	X	X	X	X
ECONOMIZER						
Standard Economizer (Not for Title 24)						
Standard Downflow Economizer with Single Temperature Control - With Barometric Relief Dampers and Air Hoods		24K57	X	X	X	X
Standard Horizontal Economizer with Single Temperature Control - With Barometric Relief Dampers and Air Hoods		24K58	X	X	X	X
Standard Economizer Controls (Not for Title 24)						
Single Enthalpy Control		21Z09	X	X	X	X
Differential Enthalpy Control (order 2)		21Z09	X	X	X	X
High Performance Economizer (Approved for California Title 24 Building Standards / AMCA Class 1A Certified)						
High Performance Downflow Economizer with Single Temperature Control - With Barometric Relief Dampers and Air Hoods		24F99	OX	OX	OX	OX
High Performance Horizontal Economizer with Single Temperature Control - With Barometric Relief Dampers and Air Hoods		24G01	X	X	X	X
High Performance Economizer Controls						
Single Enthalpy Control		24G11	X	X	X	X
Differential Enthalpy Control (order 2) (Not for Title 24)		24G11	X	X	X	X
Economizer Accessories						
WLAN Stick (For High Performance Economizer only)		23K58	X	X	X	X
OUTDOOR AIR						
Outdoor Air Dampers						
Motorized Dampers with outdoor air hood		14G36	X	X	X	X
Manual Dampers with outdoor air hood		14G37	X	X	X	X

¹ Canada requires a minimum 20 amp circuit. Select 20 amp, non-powered, field wired GFI.

NOTE - Order numbers shown are for ordering field installed accessories.

OX - Configure To Order (Factory Installed) or Field Installed

O = Configure To Order (Factory Installed)

X = Field Installed

OPTIONS / ACCESSORIES

Item Description	Order Number	Size				
		092	102	120	150	
POWER EXHAUST						
Standard Static (Downflow)	208/230V-3ph	10Z70	X	X	X	X
Standard Static (Horizontal)	208/230V-3ph	24E01	X	X	X	X
575V Transformer Kit	575V-3ph	59E02	X	X	X	X
NOTE - Order 575V Transformer Kit with 208/230V Power Exhaust Fan for 575V applications. Order two kits for downflow models, order one kit for horizontal models.						

ROOF CURBS

Hybrid Roof Curbs, Downflow

8 in. height	10Z25	X	X	X	X
14 in. height	10Z26	X	X	X	X
18 in. height	10Z27	X	X	X	X
24 in. height	10Z28	X	X	X	X

CEILING DIFFUSERS

Step-Down - Order one	RTD11-95S	13K61	X			
	RTD11-135S	13K62		X	X	
	RTD11-185S	13K63				X
Flush - Order one	FD11-95S	13K56	X			
	FD11-135S	13K57		X	X	
	FD11-185S	13K58				X

NOTE - Ceiling Diffuser Transitions are not furnished and must be field fabricated.

NOTE - Order numbers shown are for ordering field installed accessories.

OX - Configure To Order (Factory Installed) or Field Installed

O = Configure To Order (Factory Installed)

X = Field Installed

SPECIFICATIONS		UNIT			
Model		ZGD092S5T	ZGD102S5T	ZGD120S5M	ZGD150S5M
Nominal Tonnage		7.5	8.5	10	12.5
Efficiency Type		Standard	Standard	Standard	Standard
Blower Type		Two Speed Belt Drive	Two Speed Belt Drive	MSAV® Multi-Stage Air Volume	MSAV® Multi-Stage Air Volume
Cooling Performance	Gross Cooling Capacity (Btuh)	89,700	100,200	118,200	140,200
	¹ Net Cooling Capacity (Btuh)	88,000	98,000	115,000	136,000
	¹ AHRI Rated Air Flow (cfm)	2700	2800	3200	4100
	¹ IEER (Btuh/Watt)	15.0	14.6	15.0	15.0
	¹ EER (Btuh/Watt)	11.0	11.0	11.0	10.8
	Total Unit Power - kW	7.9	8.8	9.7	12.8
Sound Rating Number	dBA	84	84	90	91
Refrigerant	Type	R-454B	R-454B	R-454B	R-454B
	Circuit 1	3 lbs. 14 oz.	3 lbs. 15 oz.	4 lbs. 0 oz.	4 lbs. 12 oz.
	Circuit 2	4 lbs. 4 oz.	3 lbs. 12 oz.	4 lbs. 4 oz.	5 lbs. 12 oz.
Gas Heating Options Available - See page 17		Standard (2 stage), Medium (2 Stage), High (2 Stage)			
Compressor Type (number)		(1) Two-Stage Scroll, (1) Single-Stage Scroll			
Outdoor Coils	Net face area - ft. ²	20.9	20.9	28.0	28.0
	Rows	1	1	1	1
	Fins - in.	23	23	23	20
Outdoor Coil Fans	Motor HP (number and type)	1/3 (2 PSC)	1/3 (2 PSC)	1/2 (2 PSC)	1/2 (2 PSC)
	Rpm	1075	1075	1075	1075
	Watts	740	740	930	950
	Diameter (Number) - in.	(2) 24	(2) 24	(2) 24	(2) 24
	Blades	3	3	3	3
	Total Air volume - cfm	8800	8800	9600	9600
Indoor Coils	Net face area - ft. ²	11.6	11.6	11.6	11.6
	Rows	2	2	2	2
	Fins - in.	20	20	20	20
	Condensate drain size (NPT) - in.	(2) 1			
	Expansion device type	Circuit 1 - Balanced Port Thermostatic Expansion Valve, removable element head Circuit 2 - Refrigerant Metering Orifice		Both Circuits - Balanced Port Thermostatic Expansion Valve, removable element head	
² Indoor Blower & Drive Selection	Nominal motor HP	2		3	5
	Motor - Drive kit number	Kit #1 590-890 rpm Kit #2 800-1105 rpm Kit #3 795-1195 rpm		Kit #4 730-970 rpm Kit #5 940-1200 rpm Kit #6 1015-1300 rpm	Kit #10 900-1135 rpm Kit #11 1040-1315 rpm
		(1) 15 X 15			
	Wheel (Number) diameter x width - in.	(1) 15 X 15			
	Filters	Type of filter	Disposable		
	Number and size - in.	(4) 20 x 24 x 2			
Line voltage data (Volts-Phase-Hz)		208/230-3-60 460-3-60 575-3-60			

NOTE - Net capacity includes evaporator blower motor heat deduction. Gross capacity does not include evaporator blower motor heat deduction.

¹ AHRI Certified to AHRI Standard 340/360; 95°F outdoor air temperature and 80°F db/67°F wb entering evaporator air; minimum external duct static pressure.

² Using total air volume and system static pressure requirements determine from blower performance tables rpm and motor output required. Maximum usable output of motors furnished are shown. If motors of comparable output are used, be sure to keep within the service factor limitations outlined on the motor nameplate.

NOTE - Motor service factor limit - 1.0.

SPECIFICATIONS		GAS HEAT		
Heat Input Type		Standard	Medium	High
Number of Gas Heat Stages		2	2	2
Input - Btuh	1st Stage	85,000	117,000	156,000
	2nd Stage	130,000	180,000	240,000
Output - Btuh	2nd Stage	105,000	146,000	194,000
Temperature Rise Range - °F		15-45	30-60	40-70
Minimum air volume - cfm		2150	2250	2600
¹ Thermal Efficiency		81%	81%	81%
Gas Supply Connections		3/4 in NPT	3/4 in NPT	3/4 in NPT
Recommended Gas Supply Pressure - Nat. / LPG		7 / 11 in. w.g.		
Gas Supply Pressure Range	Min. / Max. (Natural)	4.5 / 10.5 in. w.g.		
	Min. / Max. (LPG)	10.8 / 13.5 in. w.g.		

¹ Thermal Efficiency at full input.

HIGH ALTITUDE DERATE

NOTE - Units may be installed at altitudes up to 2000 feet above sea level without any modifications.

At altitudes above 2000 feet units must be derated to match gas manifold pressures shown in table below.

At altitudes above 4500 feet unit must be derated 4% for each 1000 feet above sea level.

NOTE - This is the only permissible derate for these units.

Refer to the Installation Instructions for more detailed information.

Heat Input Type	Altitude Feet	Gas Manifold Pressure in. w.g.		Input Rate (Btuh)
		Natural Gas	LPG/ Propane	
Standard (2 stage)	2001 - 4500	1.6 / 3.1	4.4 / 8.9	85,000 / 120,000
Medium (2 stage)	2001 - 4500	1.6 / 3.1	4.4 / 8.9	117,000 / 166,000
High (2 stage)	2001 - 4500	1.6 / 3.1	4.4 / 8.9	156,000 / 221,000

RATINGS

NOTE – For Temperatures and Capacities not shown in tables, see bulletin – Cooling Unit Rating Table Correction Factor Data in Miscellaneous Engineering Data section.

7.5 TON - ZGD092S5T (1 COMPRESSOR - PART LOAD)

Entering Wet Bulb Temperature	Total Air Volume	Outdoor Air Temperature Entering Outdoor Coil																				
		65°F						75°F					85°F					95°F				
		Total Cool Cap.	Comp. Motor Input	Sensible To Total Ratio (S/T)			Total Cool Cap.	Comp. Motor Input	Sensible To Total Ratio (S/T)			Total Cool Cap.	Comp. Motor Input	Sensible To Total Ratio (S/T)			Total Cool Cap.	Comp. Motor Input	Sensible To Total Ratio (S/T)			
				Dry Bulb					Dry Bulb					Dry Bulb					Dry Bulb			
cfm	kBtuh	kW	75°F	80°F	85°F	kBtuh	kW	75°F	80°F	85°F	kBtuh	kW	75°F	80°F	85°F	kBtuh	kW	75°F	80°F	85°F		
63°F	1600	45.3	2.35	0.81	0.97	1	42.2	2.76	0.83	0.99	1	38.7	3.22	0.85	1	1	35.6	3.73	0.88	1	1	
	1980	48.3	2.3	0.87	1	1	45.3	2.71	0.89	1	1	42.1	3.17	0.92	1	1	38.2	3.7	0.97	1	1	
	2360	51	2.28	0.93	1	1	47.8	2.68	0.95	1	1	44.1	3.14	0.98	1	1	40.4	3.66	1	1	1	
67°F	1600	48	2.31	0.63	0.78	0.93	44.7	2.72	0.63	0.8	0.96	40.7	3.19	0.64	0.83	0.99	37	3.71	0.65	0.86	1	
	1980	50.4	2.28	0.67	0.85	1	47.1	2.69	0.68	0.87	1	43.4	3.15	0.69	0.89	1	39	3.68	0.71	0.94	1	
	2360	52.3	2.26	0.71	0.91	1	48.8	2.66	0.72	0.93	1	44.6	3.13	0.73	0.97	1	40.4	3.66	0.75	1	1	
71°F	1600	50.8	2.28	0.47	0.62	0.76	47.5	2.68	0.46	0.62	0.78	43.5	3.15	0.46	0.63	0.8	39.5	3.68	0.45	0.65	0.83	
	1980	53.3	2.25	0.49	0.66	0.83	49.9	2.65	0.48	0.67	0.85	45.6	3.12	0.49	0.69	0.87	41.4	3.65	0.47	0.71	0.91	
	2360	55	2.23	0.5	0.7	0.89	51.4	2.63	0.5	0.71	0.91	47.1	3.1	0.51	0.73	0.94	42.9	3.63	0.51	0.75	0.98	

7.5 TON - ZGD092S5T (2 COMPRESSORS - PART LOAD / FULL LOAD)

Entering Wet Bulb Temperature	Total Air Volume	Outdoor Air Temperature Entering Outdoor Coil																				
		85°F						95°F					105°F					115°F				
		Total Cool Cap.	Comp. Motor Input	Sensible To Total Ratio (S/T)			Total Cool Cap.	Comp. Motor Input	Sensible To Total Ratio (S/T)			Total Cool Cap.	Comp. Motor Input	Sensible To Total Ratio (S/T)			Total Cool Cap.	Comp. Motor Input	Sensible To Total Ratio (S/T)			
				Dry Bulb					Dry Bulb					Dry Bulb					Dry Bulb			
cfm	kBtuh	kW	75°F	80°F	85°F	kBtuh	kW	75°F	80°F	85°F	kBtuh	kW	75°F	80°F	85°F	kBtuh	kW	75°F	80°F	85°F		
63°F	1800	75.1	4.28	0.84	1	1	70.2	4.95	0.86	1	1	64.9	5.69	0.88	1	1	59.2	6.56	0.91	1	1	
	2250	80.2	4.26	0.9	1	1	74.8	4.94	0.93	1	1	69.1	5.67	0.96	1	1	63.5	6.54	0.99	1	1	
	2700	83.8	4.24	0.97	1	1	78.4	4.92	0.99	1	1	72.4	5.67	1	1	1	66.3	6.51	1	1	1	
67°F	1800	78.8	4.26	0.64	0.82	0.98	73.4	4.94	0.65	0.84	1	67.2	5.68	0.66	0.86	1	61.2	6.56	0.67	0.89	1	
	2250	82.6	4.25	0.69	0.88	1	76.5	4.93	0.7	0.91	1	70.2	5.67	0.71	0.94	1	64	6.54	0.72	0.97	1	
	2700	84.9	4.23	0.73	0.95	1	79	4.91	0.74	0.98	1	72.6	5.67	0.76	1	1	66.3	6.51	0.77	1	1	
71°F	1800	82.8	4.25	0.47	0.64	0.8	76.9	4.92	0.46	0.65	0.81	70.8	5.67	0.46	0.66	0.84	64.6	6.54	0.45	0.67	0.87	
	2250	86.4	4.22	0.49	0.68	0.87	80.6	4.91	0.49	0.69	0.89	74.1	5.66	0.49	0.71	0.92	67.5	6.5	0.48	0.72	0.95	
	2700	89	4.21	0.52	0.73	0.93	82.9	4.9	0.52	0.74	0.96	76.4	5.65	0.51	0.76	0.99	69.6	6.49	0.5	0.78	1	

7.5 TON - ZGD092S5T (2 COMPRESSORS - FULL LOAD)

Entering Wet Bulb Temperature	Total Air Volume	Outdoor Air Temperature Entering Outdoor Coil																				
		85°F						95°F					105°F					115°F				
		Total Cool Cap.	Comp. Motor Input	Sensible To Total Ratio (S/T)			Total Cool Cap.	Comp. Motor Input	Sensible To Total Ratio (S/T)			Total Cool Cap.	Comp. Motor Input	Sensible To Total Ratio (S/T)			Total Cool Cap.	Comp. Motor Input	Sensible To Total Ratio (S/T)			
				Dry Bulb					Dry Bulb					Dry Bulb					Dry Bulb			
cfm	kBtuh	kW	75°F	80°F	85°F	kBtuh	kW	75°F	80°F	85°F	kBtuh	kW	75°F	80°F	85°F	kBtuh	kW	75°F	80°F	85°F		
63°F	2400	98.3	5.4	0.86	0.99	1	92.2	6.09	0.88	1	1	86.5	6.89	0.9	1	1	80.1	7.8	0.92	1	1	
	3000	103.5	5.45	0.93	1	1	97.5	6.15	0.95	1	1	91.3	6.95	0.96	1	1	84.8	7.87	0.98	1	1	
	3600	107.7	5.49	0.97	1	1	101.5	6.2	0.99	1	1	95	7	1	1	1	88.1	7.92	1	1	1	
67°F	2400	102.2	5.45	0.66	0.84	0.98	95.8	6.14	0.67	0.86	0.99	89	6.93	0.68	0.88	1	82	7.84	0.69	0.91	1	
	3000	105.8	5.49	0.7	0.91	1	99.3	6.19	0.71	0.93	1	92.5	6.98	0.73	0.95	1	85.5	7.89	0.74	0.97	1	
	3600	109	5.52	0.75	0.96	1	102.3	6.22	0.76	0.98	1	95.5	7.02	0.78	1	1	88.3	7.92	0.79	1	1	
71°F	2400	107.1	5.49	0.48	0.66	0.82	100.6	6.2	0.48	0.66	0.84	93.8	6.99	0.47	0.67	0.86	86.7	7.9	0.47	0.69	0.89	
	3000	111.1	5.54	0.5	0.7	0.89	104.4	6.24	0.5	0.71	0.92	97.2	7.04	0.51	0.73	0.94	89.7	7.94	0.5	0.74	0.97	
	3600	113.8	5.57	0.52	0.75	0.95	106.7	6.26	0.53	0.76	0.97	99.5	7.07	0.53	0.78	0.99	91.6	7.97	0.53	0.8	1	

RATINGS

NOTE – For Temperatures and Capacities not shown in tables, see bulletin – Cooling Unit Rating Table Correction Factor Data in Miscellaneous Engineering Data section.

8.5 TON - ZGD102S5T (1 COMPRESSOR - PART LOAD)

Entering Wet Bulb Temperature	Total Air Volume	Outdoor Air Temperature Entering Outdoor Coil																							
		65°F						75°F						85°F						95°F					
		Total Cool Cap.	Comp. Motor Input	Sensible To Total Ratio (S/T)			Total Cool Cap.	Comp. Motor Input	Sensible To Total Ratio (S/T)			Total Cool Cap.	Comp. Motor Input	Sensible To Total Ratio (S/T)			Total Cool Cap.	Comp. Motor Input	Sensible To Total Ratio (S/T)						
				Dry Bulb					Dry Bulb					Dry Bulb					Dry Bulb						
cfm	kBtuh	kW	75°F	80°F	85°F	kBtuh	kW	75°F	80°F	85°F	kBtuh	kW	75°F	80°F	85°F	kBtuh	kW	75°F	80°F	85°F					
63°F	1800	48.2	2.35	0.84	1	1	45.3	2.75	0.86	1	1	41.9	3.22	0.89	1	1	38.1	3.75	0.93	1	1				
	2250	51.7	2.31	0.91	1	1	48.6	2.71	0.94	1	1	44.9	3.18	0.97	1	1	41	3.7	1	1	1				
	2700	54.3	2.28	0.98	1	1	51.1	2.68	1	1	1	47.4	3.14	1	1	1	43.2	3.67	1	1	1				
67°F	1800	50.8	2.31	0.65	0.82	0.98	47.5	2.73	0.66	0.84	1	43.7	3.2	0.67	0.86	1	39.3	3.73	0.69	0.82	1				
	2250	53.4	2.29	0.7	0.89	1	49.8	2.69	0.72	0.92	1	45.9	3.16	0.72	0.95	1	41.3	3.7	0.75	0.91	1				
	2700	55.1	2.27	0.74	0.95	1	51.6	2.67	0.75	0.98	1	47.5	3.15	0.77	1	1	43.2	3.67	0.8	0.99	1				
71°F	1800	53.8	2.28	0.48	0.64	0.8	50.3	2.69	0.48	0.65	0.82	46.1	3.16	0.47	0.66	0.84	41.9	3.69	0.47	0.63	0.8				
	2250	56.2	2.25	0.49	0.69	0.87	52.6	2.66	0.49	0.7	0.89	48.1	3.14	0.5	0.72	0.92	43.8	3.67	0.51	0.68	0.89				
	2700	57.9	2.23	0.52	0.74	0.94	53.9	2.64	0.53	0.75	0.96	49.8	3.12	0.53	0.77	1	45.3	3.64	0.54	0.73	0.97				

8.5 TON - ZGD102S5T (2 COMPRESSORS - PART LOAD / FULL LOAD)

Entering Wet Bulb Temperature	Total Air Volume	Outdoor Air Temperature Entering Outdoor Coil																							
		85°F						95°F						105°F						115°F					
		Total Cool Cap.	Comp. Motor Input	Sensible To Total Ratio (S/T)			Total Cool Cap.	Comp. Motor Input	Sensible To Total Ratio (S/T)			Total Cool Cap.	Comp. Motor Input	Sensible To Total Ratio (S/T)			Total Cool Cap.	Comp. Motor Input	Sensible To Total Ratio (S/T)						
				Dry Bulb					Dry Bulb					Dry Bulb					Dry Bulb						
cfm	kBtuh	kW	75°F	80°F	85°F	kBtuh	kW	75°F	80°F	85°F	kBtuh	kW	75°F	80°F	85°F	kBtuh	kW	75°F	80°F	85°F					
63°F	2040	87.3	4.95	0.83	0.98	1	81.5	5.72	0.85	0.99	1	75.8	6.6	0.87	1	1	69.5	7.59	0.9	0.86	0.99				
	2550	91.9	4.94	0.9	1	1	86.2	5.72	0.92	1	1	80.5	6.6	0.94	1	1	74.1	7.56	0.95	0.93	1				
	3060	96	4.93	0.95	1	1	90.3	5.7	0.96	1	1	83.5	6.57	0.97	1	1	76.8	7.55	0.99	0.99	1				
67°F	2040	90.8	4.95	0.65	0.81	0.96	84.6	5.73	0.65	0.83	0.97	78.7	6.6	0.66	0.85	0.98	71.7	7.59	0.67	0.68	0.83				
	2550	95	4.94	0.69	0.88	1	88.6	5.71	0.69	0.9	1	81.9	6.58	0.7	0.93	1	74.7	7.57	0.72	0.73	0.9				
	3060	98	4.94	0.72	0.94	1	91.5	5.71	0.74	0.96	1	84.8	6.58	0.75	0.97	1	78	7.58	0.77	0.8	0.97				
71°F	2040	94.9	4.94	0.47	0.64	0.8	89	5.7	0.46	0.65	0.81	82	6.57	0.47	0.66	0.84	75	7.56	0.45	0.52	0.66				
	2550	99.2	4.93	0.49	0.69	0.86	92.5	5.71	0.49	0.69	0.88	85.8	6.58	0.49	0.7	0.91	78.9	7.58	0.49	0.56	0.71				
	3060	102.1	4.93	0.51	0.72	0.92	95.4	5.7	0.51	0.73	0.95	88.3	6.58	0.51	0.75	0.96	81.2	7.58	0.51	0.6	0.78				

8.5 TON - ZGD102S5T (2 COMPRESSORS - FULL LOAD)

Entering Wet Bulb Temperature	Total Air Volume	Outdoor Air Temperature Entering Outdoor Coil																							
		85°F						95°F						105°F						115°F					
		Total Cool Cap.	Comp. Motor Input	Sensible To Total Ratio (S/T)			Total Cool Cap.	Comp. Motor Input	Sensible To Total Ratio (S/T)			Total Cool Cap.	Comp. Motor Input	Sensible To Total Ratio (S/T)			Total Cool Cap.	Comp. Motor Input	Sensible To Total Ratio (S/T)						
				Dry Bulb					Dry Bulb					Dry Bulb					Dry Bulb						
cfm	kBtuh	kW	75°F	80°F	85°F	kBtuh	kW	75°F	80°F	85°F	kBtuh	kW	75°F	80°F	85°F	kBtuh	kW	75°F	80°F	85°F					
63°F	2720	107.2	6.09	0.92	1	1	100.9	7.05	0.94	1	1	94.5	8.18	0.96	1	1	87	9.38	0.97	0.87	1				
	3400	112.8	6.07	0.97	1	1	106	7.04	0.98	1	1	99	8.14	0.99	1	1	91.5	9.39	1	0.95	1				
	4080	116.5	6.06	1	1	1	109.6	7.04	1	1	1	102	8.14	1	1	1	94.7	9.39	1	1	1				
67°F	2720	110.4	6.09	0.7	0.9	1	103.2	7.06	0.71	0.92	1	95.7	8.16	0.72	0.94	1	87.8	9.39	0.74	0.71	0.84				
	3400	114.4	6.08	0.75	0.96	1	107.3	7.05	0.76	0.97	1	99.6	8.14	0.78	0.99	1	92	9.39	0.8	0.79	0.92				
	4080	117.4	6.07	0.79	0.99	1	110.1	7.04	0.81	1	1	101.9	8.14	0.83	1	1	94.7	9.39	0.85	0.82	0.99				
71°F	2720	115.2	6.08	0.5	0.7	0.88	107.9	7.05	0.5	0.71	0.9	100.2	8.15	0.5	0.72	0.93	92.5	9.4	0.49	0.53	0.68				
	3400	119.2	6.07	0.53	0.75	0.95	111.8	7.07	0.53	0.76	0.96	103.4	8.15	0.53	0.78	0.98	95.5	9.4	0.53	0.58	0.75				
	4080	122	6.06	0.55	0.79	0.99	114.1	7.06	0.55	0.81	1	105.8	8.15	0.55	0.83	1	97.8	9.41	0.55	0.61	0.81				

RATINGS

NOTE – For Temperatures and Capacities not shown in tables, see bulletin – Cooling Unit Rating Table Correction Factor Data in Miscellaneous Engineering Data section.

10 TON - ZGD120S5M (1 COMPRESSOR - PART LOAD)

Entering Wet Bulb Temperature	Total Air Volume	Outdoor Air Temperature Entering Outdoor Coil																							
		65°F						75°F						85°F						95°F					
		Total Cool Cap.	Comp. Motor Input	Sensible To Total Ratio (S/T)			Total Cool Cap.	Comp. Motor Input	Sensible To Total Ratio (S/T)			Total Cool Cap.	Comp. Motor Input	Sensible To Total Ratio (S/T)			Total Cool Cap.	Comp. Motor Input	Sensible To Total Ratio (S/T)						
				Dry Bulb					Dry Bulb					Dry Bulb					Dry Bulb						
cfm	kBtuh	kW	75°F	80°F	85°F	kBtuh	kW	75°F	80°F	85°F	kBtuh	kW	75°F	80°F	85°F	kBtuh	kW	75°F	80°F	85°F					
63°F	2110	46.3	2.31	0.86	1	1	43.2	2.7	0.88	1	1	39.6	3.15	0.9	1	1	35.8	3.65	0.94	1	1				
	2640	49.2	2.28	0.92	1	1	45.9	2.67	0.94	1	1	42.2	3.12	0.98	1	1	38	3.63	1	1	1				
	3170	51.5	2.25	0.98	1	1	47.7	2.65	1	1	1	44.1	3.1	1	1	1	39.5	3.61	1	1	1				
67°F	2110	48.4	2.29	0.66	0.84	1	45	2.68	0.67	0.86	1	40.9	3.14	0.68	0.89	1	36.7	3.64	0.69	0.9	1				
	2640	50.6	2.26	0.7	0.91	1	46.9	2.66	0.71	0.93	1	42.6	3.11	0.72	0.96	1	38.3	3.62	0.73	0.99	1				
71°F	3170	52.1	2.25	0.73	0.98	1	48.1	2.65	0.74	0.99	1	44.1	3.1	0.75	1	1	39.5	3.61	0.76	1	1				
	2110	50.4	2.27	0.49	0.66	0.82	46.9	2.66	0.48	0.67	0.84	42.8	3.11	0.49	0.68	0.86	38.5	3.62	0.45	0.68	0.88				
	2640	52.3	2.25	0.5	0.7	0.89	48.7	2.65	0.49	0.71	0.91	44.4	3.1	0.46	0.72	0.94	39.9	3.61	0.48	0.74	0.97				
	3170	53.8	2.23	0.5	0.74	0.95	49.4	2.64	0.5	0.74	0.97	45.5	3.08	0.51	0.76	1	40.6	3.59	0.52	0.8	1				

10 TON - ZGD120S5M (2 COMPRESSORS - PART LOAD / FULL LOAD)

Entering Wet Bulb Temperature	Total Air Volume	Outdoor Air Temperature Entering Outdoor Coil																							
		85°F						95°F						105°F						115°F					
		Total Cool Cap.	Comp. Motor Input	Sensible To Total Ratio (S/T)			Total Cool Cap.	Comp. Motor Input	Sensible To Total Ratio (S/T)			Total Cool Cap.	Comp. Motor Input	Sensible To Total Ratio (S/T)			Total Cool Cap.	Comp. Motor Input	Sensible To Total Ratio (S/T)						
				Dry Bulb					Dry Bulb					Dry Bulb					Dry Bulb						
cfm	kBtuh	kW	75°F	80°F	85°F	kBtuh	kW	75°F	80°F	85°F	kBtuh	kW	75°F	80°F	85°F	kBtuh	kW	75°F	80°F	85°F					
63°F	2400	101.7	5.79	0.86	0.99	1	95.6	6.61	0.88	1	1	88.7	7.62	0.9	1	1	81.6	8.78	0.92	0.87	0.98				
	3000	107.5	5.77	0.93	1	1	100.8	6.63	0.94	1	1	94.1	7.65	0.95	1	1	86.5	8.77	0.97	0.93	1				
	3600	112.1	5.78	0.97	1	1	105.4	6.66	0.98	1	1	97.9	7.62	0.99	1	1	90.3	8.77	1	0.99	1				
67°F	2400	105.4	5.78	0.66	0.84	0.97	98.6	6.62	0.67	0.86	0.98	91	7.66	0.68	0.88	1	83.3	8.79	0.69	0.71	0.85				
	3000	110	5.77	0.71	0.91	1	102.4	6.64	0.72	0.93	1	95.4	7.66	0.73	0.95	1	87.6	8.78	0.75	0.78	0.91				
	3600	113.8	5.79	0.76	0.96	1	106.9	6.72	0.77	0.97	1	99	7.63	0.78	0.99	1	90.9	8.77	0.8	0.83	0.97				
71°F	2400	110.1	5.77	0.48	0.66	0.82	102.7	6.63	0.48	0.67	0.84	95.7	7.66	0.48	0.68	0.86	87.7	8.78	0.48	0.53	0.68				
	3000	114.4	5.78	0.51	0.71	0.9	106.9	6.72	0.51	0.72	0.92	99.1	7.62	0.51	0.74	0.94	91.1	8.78	0.51	0.58	0.76				
	3600	117.8	5.78	0.53	0.76	0.95	110.1	6.72	0.54	0.77	0.97	101.9	7.62	0.54	0.79	0.98	93.5	8.78	0.53	0.62	0.81				

10 TON - ZGD120S5M (2 COMPRESSORS - FULL LOAD)

Entering Wet Bulb Temperature	Total Air Volume	Outdoor Air Temperature Entering Outdoor Coil																							
		85°F						95°F						105°F						115°F					
		Total Cool Cap.	Comp. Motor Input	Sensible To Total Ratio (S/T)			Total Cool Cap.	Comp. Motor Input	Sensible To Total Ratio (S/T)			Total Cool Cap.	Comp. Motor Input	Sensible To Total Ratio (S/T)			Total Cool Cap.	Comp. Motor Input	Sensible To Total Ratio (S/T)						
				Dry Bulb					Dry Bulb					Dry Bulb					Dry Bulb						
cfm	kBtuh	kW	75°F	80°F	85°F	kBtuh	kW	75°F	80°F	85°F	kBtuh	kW	75°F	80°F	85°F	kBtuh	kW	75°F	80°F	85°F					
63°F	3200	127.5	7.09	0.89	1	1	120.2	7.97	0.91	1	1	112.9	9.05	0.93	1	1	105.1	10.19	0.96	0.89	1				
	4000	133.8	7.16	0.97	1	1	126.2	8.1	0.99	1	1	118.2	9.07	1	1	1	110	10.3	1	0.95	1				
	4800	138.7	7.23	1	1	1	130.7	8.15	1	1	1	122.2	9.13	1	1	1	113.2	10.35	1	1	1				
67°F	3200	131.4	7.13	0.69	0.88	1	123.2	8	0.7	0.9	1	115.1	9.08	0.7	0.92	1	107.4	10.21	0.72	0.74	0.86				
	4000	135.6	7.18	0.74	0.95	1	127.7	8.11	0.74	0.98	1	118.9	9.07	0.76	1	1	110.4	10.3	0.77	0.81	0.93				
	4800	138.9	7.23	0.78	1	1	131.2	8.16	0.79	1	1	122.3	9.13	0.8	1	1	113.5	10.36	0.83	0.85	0.99				
71°F	3200	136.8	7.21	0.5	0.69	0.86	128.8	8.13	0.5	0.7	0.88	120.3	9.1	0.5	0.71	0.91	111.3	10.32	0.5	0.57	0.72				
	4000	141.4	7.27	0.53	0.74	0.94	132.7	8.17	0.53	0.75	0.96	123.8	9.15	0.53	0.76	0.99	114.6	10.36	0.52	0.6	0.78				
	4800	144.1	7.3	0.54	0.78	1	135.5	8.16	0.54	0.8	1	126.3	9.24	0.55	0.82	1	116.2	10.41	0.56	0.65	0.84				

RATINGS

NOTE – For Temperatures and Capacities not shown in tables, see bulletin – Cooling Unit Rating Table Correction Factor Data in Miscellaneous Engineering Data section.

12.5 TON - ZGD150S5M (1 COMPRESSOR - PART LOAD)

Entering Wet Bulb Temperature	Total Air Volume	Outdoor Air Temperature Entering Outdoor Coil																							
		65°F						75°F						85°F						95°F					
		Total Cool Cap.	Comp. Motor Input	Sensible To Total Ratio (S/T)			Total Cool Cap.	Comp. Motor Input	Sensible To Total Ratio (S/T)			Total Cool Cap.	Comp. Motor Input	Sensible To Total Ratio (S/T)			Total Cool Cap.	Comp. Motor Input	Sensible To Total Ratio (S/T)						
				Dry Bulb					Dry Bulb					Dry Bulb					Dry Bulb						
cfm	kBtuh	kW	75°F	80°F	85°F	kBtuh	kW	75°F	80°F	85°F	kBtuh	kW	75°F	80°F	85°F	kBtuh	kW	75°F	80°F	85°F					
63°F	2640	60	2.67	0.96	1	1	55.5	3.13	0.99	1	1	50.6	3.64	1	1	1	45.6	4.2	1	1	1				
	3300	64.4	2.64	1	1	1	59.6	3.1	1	1	1	54.5	3.62	1	1	1	49.1	4.18	1	1	1				
	3960	67.8	2.61	1	1	1	62.8	3.08	1	1	1	57.4	3.6	1	1	1	51.8	4.16	1	1	1				
67°F	2640	60.9	2.66	0.71	0.94	1	55.8	3.13	0.73	0.97	1	50.7	3.64	0.74	0.99	1	45.6	4.2	0.77	1	1				
	3300	64.5	2.63	0.8	1	1	59.6	3.1	0.82	1	1	54.5	3.62	0.85	1	1	49.1	4.18	0.89	1	1				
	3960	67.8	2.61	0.88	1	1	62.8	3.08	0.9	1	1	57.4	3.6	0.94	1	1	51.7	4.16	0.98	1	1				
71°F	2640	65.4	2.63	0.49	0.71	0.92	59.8	3.1	0.48	0.72	0.95	54.2	3.62	0.47	0.74	0.98	48.1	4.18	0.47	0.77	1				
	3300	67.8	2.62	0.53	0.79	1	62.3	3.09	0.53	0.81	1	56.5	3.61	0.53	0.84	1	50.5	4.17	0.53	0.88	1				
	3960	69.6	2.6	0.57	0.87	1	64	3.08	0.58	0.9	1	58	3.59	0.58	0.94	1	52	4.16	0.59	0.98	1				

12.5 TON - ZGD150S5M (2 COMPRESSORS - PART LOAD / FULL LOAD)

Entering Wet Bulb Temperature	Total Air Volume	Outdoor Air Temperature Entering Outdoor Coil																							
		85°F						95°F						105°F						115°F					
		Total Cool Cap.	Comp. Motor Input	Sensible To Total Ratio (S/T)			Total Cool Cap.	Comp. Motor Input	Sensible To Total Ratio (S/T)			Total Cool Cap.	Comp. Motor Input	Sensible To Total Ratio (S/T)			Total Cool Cap.	Comp. Motor Input	Sensible To Total Ratio (S/T)						
				Dry Bulb					Dry Bulb					Dry Bulb					Dry Bulb						
cfm	kBtuh	kW	75°F	80°F	85°F	kBtuh	kW	75°F	80°F	85°F	kBtuh	kW	75°F	80°F	85°F	kBtuh	kW	75°F	80°F	85°F					
63°F	3000	121.9	7.62	0.44	0.71	0.96	112.4	8.71	0.46	0.73	0.99	102.7	9.92	0.48	0.75	1	92.7	11.26	0.5	0.81	0.98				
	3750	129.7	7.64	0.52	0.86	1	120.3	8.76	0.57	0.9	1	111.2	9.98	0.61	0.98	1	102.4	11.32	0.64	1	1				
	4500	135.4	7.64	0.64	0.96	1	126.4	8.78	0.69	1	1	117.8	10	0.75	1	1	109.3	11.39	0.79	1	1				
67°F	3000	132.5	7.63	0.16	0.42	0.62	122.7	8.75	0.14	0.44	0.68	112.4	9.98	0.12	0.41	0.7	101.4	11.33	0.12	0.43	0.74				
	3750	138.5	7.65	0.2	0.49	0.81	127.8	8.78	0.19	0.52	0.83	117.4	10	0.2	0.53	0.89	107	11.36	0.23	0.59	0.96				
	4500	143.8	7.66	0.26	0.6	0.93	132.9	8.79	0.28	0.64	0.94	122.6	10.03	0.32	0.71	1	110.9	11.39	0.34	0.77	1				
71°F	3000	144	7.65	0.1	0.15	0.36	133.6	8.79	0.11	0.14	0.39	122.9	10.02	0.13	0.14	0.41	111.3	11.38	0.15	0.12	0.4				
	3750	151.2	7.67	0.1	0.2	0.45	139.5	8.81	0.1	0.18	0.47	128.1	10.06	0.14	0.18	0.5	116.2	11.42	0.16	0.19	0.56				
	4500	155.6	7.67	0.14	0.27	0.58	144.5	8.83	0.2	0.28	0.62	132.5	10.08	0.18	0.3	0.63	120	11.44	0.12	0.3	0.72				

12.5 TON - ZGD150S5M (2 COMPRESSORS - FULL LOAD)

Entering Wet Bulb Temperature	Total Air Volume	Outdoor Air Temperature Entering Outdoor Coil																							
		85°F						95°F						105°F						115°F					
		Total Cool Cap.	Comp. Motor Input	Sensible To Total Ratio (S/T)			Total Cool Cap.	Comp. Motor Input	Sensible To Total Ratio (S/T)			Total Cool Cap.	Comp. Motor Input	Sensible To Total Ratio (S/T)			Total Cool Cap.	Comp. Motor Input	Sensible To Total Ratio (S/T)						
				Dry Bulb					Dry Bulb					Dry Bulb					Dry Bulb						
cfm	kBtuh	kW	75°F	80°F	85°F	kBtuh	kW	75°F	80°F	85°F	kBtuh	kW	75°F	80°F	85°F	kBtuh	kW	75°F	80°F	85°F					
63°F	4000	151.1	8.91	0.5	0.78	1	140.8	10.12	0.52	0.82	1	130.3	11.47	0.54	0.86	1	119.4	12.97	0.57	0.91	1				
	5000	159.7	8.98	0.64	0.94	1	148.9	10.2	0.66	0.98	1	138.6	11.57	0.69	1	1	128.9	13.09	0.74	1	1				
	6000	167.7	9.04	0.76	1	1	157.4	10.28	0.79	1	1	146.8	11.66	0.84	1	1	136.3	13.19	0.9	1	1				
67°F	4000	162.2	8.98	0.19	0.46	0.72	151.7	10.21	0.18	0.47	0.75	140.2	11.57	0.18	0.49	0.79	128.5	13.07	0.18	0.52	0.85				
	5000	169.4	9.05	0.27	0.59	0.88	157.7	10.28	0.28	0.63	0.93	146.6	11.65	0.29	0.65	0.97	134.4	13.15	0.3	0.69	1				
	6000	175	9.09	0.35	0.72	0.99	163.2	10.33	0.37	0.77	1	151.3	11.71	0.39	0.8	1	138.8	13.21	0.41	0.86	1				
71°F	4000	175.1	9.07	0.1	0.16	0.41	163.5	10.31	0.11	0.16	0.43	151.6	11.69	0.13	0.16	0.44	139.8	13.2	0.15	0.16	0.47				
	5000	182.3	9.13	0.1	0.25	0.54	170.2	10.38	0.1	0.26	0.58	157.6	11.76	0.14	0.27	0.6	144.5	13.26	0.16	0.29	0.65				
	6000	187.3	9.17	0.14	0.34	0.68	174.7	10.43	0.2	0.35	0.71	161.6	11.81	0.18	0.38	0.78	148.4	13.32	0.12	0.4	0.81				

BLOWER DATA

BASE UNIT

BLOWER TABLE INCLUDES RESISTANCE FOR BASE UNIT ONLY (NO HEAT SECTION) WITH DRY INDOOR COIL AND AIR FILTERS IN PLACE. FOR ALL UNITS ADD:

- 1 – Wet indoor coil air resistance of selected unit.
- 2 – Any factory installed options air resistance (heat section, economizer, etc.)
- 3 – Any field installed accessories air resistance (duct resistance, diffuser, etc.)

Then determine from blower table blower motor output required.

See page 23 for blower motors and drives and air resistance for wet coil and options/accessories.

MAXIMUM STATIC PRESSURE WITH GAS HEAT - 2.0 in. w.g.

Maximum Static Pressure With Gas Heat - 2.0 in. w.g.
Minimum Air Volume Required For Different Gas Heat Sizes:
 Standard - 2150 cfm; Medium - 2250 cfm; High - 2600 cfm

Total Air Volume cfm	Total Static Pressure – in. w.g.																										
	0.2		0.4		0.6		0.8		1.0		1.2		1.4		1.6		1.8		2.0		2.2		2.4		2.6		
	RPM	BHP	RPM	BHP	RPM	BHP	RPM	BHP	RPM	BHP	RPM	BHP	RPM	BHP	RPM	BHP	RPM	BHP	RPM	BHP	RPM	BHP	RPM	BHP	RPM	BHP	RPM
2000	542	0.43	602	0.60	664	0.75	732	0.89	802	1.02	869	1.15	927	1.27	979	1.41	1029	1.57	1079	1.75	1129	1.95	1179	2.15	1230	2.37	
2250	560	0.55	619	0.71	681	0.86	748	1.00	817	1.14	882	1.27	939	1.41	991	1.57	1041	1.74	1090	1.93	1140	2.13	1190	2.35	1241	2.57	
2500	579	0.68	637	0.83	699	0.98	766	1.12	834	1.26	897	1.41	953	1.57	1005	1.74	1054	1.92	1103	2.12	1152	2.33	1202	2.55	1254	2.79	
2750	599	0.81	657	0.97	719	1.11	785	1.25	851	1.41	913	1.57	968	1.74	1020	1.93	1068	2.13	1116	2.34	1165	2.56	1215	2.78	1268	3.01	
3000	620	0.95	678	1.11	741	1.25	806	1.40	870	1.58	930	1.75	985	1.94	1036	2.14	1084	2.36	1131	2.58	1180	2.80	1230	3.02	1283	3.26	
3250	643	1.10	701	1.26	764	1.41	828	1.57	891	1.76	950	1.95	1003	2.16	1053	2.38	1100	2.61	1148	2.83	1196	3.06	1246	3.29	1299	3.52	
3500	667	1.26	726	1.43	788	1.58	851	1.77	913	1.97	970	2.17	1023	2.41	1071	2.65	1118	2.88	1165	3.11	1213	3.33	1264	3.57	1317	3.81	
3750	693	1.44	752	1.61	813	1.78	876	1.98	936	2.20	992	2.43	1043	2.68	1091	2.93	1137	3.17	1183	3.40	1232	3.64	1284	3.88	1338	4.13	
4000	720	1.65	779	1.82	840	2.00	902	2.22	961	2.46	1015	2.71	1064	2.98	1111	3.24	1156	3.48	1203	3.72	1253	3.96	1305	4.22	1359	4.48	
4250	748	1.86	807	2.04	868	2.24	929	2.48	986	2.75	1038	3.02	1086	3.30	1132	3.57	1177	3.81	1224	4.05	1274	4.31	1327	4.57	1382	4.85	
4500	778	2.09	837	2.28	898	2.51	957	2.78	1012	3.07	1062	3.37	1108	3.65	1154	3.92	1199	4.17	1247	4.41	1297	4.67	1350	4.94	1405	5.22	
4750	809	2.34	868	2.56	929	2.82	986	3.12	1038	3.43	1087	3.74	1132	4.03	1177	4.29	1223	4.54	1270	4.79	1321	5.04	1374	5.31	1428	5.58	
5000	841	2.62	901	2.87	960	3.17	1015	3.50	1065	3.83	1112	4.14	1157	4.43	1201	4.69	1247	4.94	1295	5.18	1345	5.42	1398	5.68	---	---	
5250	875	2.93	935	3.23	992	3.56	1044	3.91	1092	4.26	1138	4.57	1182	4.85	1226	5.10	1272	5.34	1320	5.57	---	---	---	---	---	---	
5500	911	3.30	969	3.63	1024	4.00	1074	4.37	1120	4.71	1165	5.02	1208	5.29	1253	5.53	---	---	---	---	---	---	---	---	---	---	
5750	948	3.71	1004	4.08	1056	4.48	1104	4.85	1148	5.19	1192	5.49	1235	5.74	---	---	---	---	---	---	---	---	---	---	---	---	
6000	985	4.18	1039	4.59	1088	5.00	1134	5.37	1177	5.69	---	---	---	---	---	---	---	---	---	---	---	---	---	---	---	---	
6250	1022	4.70	1073	5.14	1120	5.54	---	---	---	---	---	---	---	---	---	---	---	---	---	---	---	---	---	---	---	---	

BLOWER DATA

FACTORY INSTALLED BELT DRIVE KIT SPECIFICATIONS

Nominal HP	Drive Kit Number	RPM Range
2	1	590 - 890
2	2	800 - 1105
2	3	795 - 1195
3	4	730 - 970
3	5	940 - 1200
3	6	1015 - 1300
5	10	900 - 1135
5	11	1040 - 1315

NOTE - Using total air volume and system static pressure requirements determine from blower performance tables rpm and motor output required. Maximum usable output of motors furnished are shown. If motors of comparable output are used, be sure to keep within the service factor limitations outlined on the motor nameplate.

NOTE - Motor service factor limit - 1.0.

POWER EXHAUST FAN PERFORMANCE

Return Air System Static Pressure	Air Volume Exhausted
in. w.g.	cfm
0	3575
0.05	3405
0.10	3550
0.15	3245
0.20	3115
0.25	3020
0.30	2900
0.35	2785

FACTORY INSTALLED OPTIONS/FIELD INSTALLED ACCESSORY AIR RESISTANCE - in. w.g.

Air Volume cfm	Wet Indoor Coil	Gas Heat Exchanger			Economizer
		Standard Heat	Medium Heat	High Heat	
1750	0.04	0.06	0.02	0.02	0.03
2000	0.05	0.07	0.05	0.06	0.05
2250	0.06	0.07	0.07	0.08	0.06
2500	0.07	0.09	0.10	0.11	0.08
2750	0.08	0.09	0.11	0.12	0.09
3000	0.09	0.11	0.12	0.13	0.11
3250	0.10	0.12	0.15	0.16	0.13
3500	0.11	0.12	0.16	0.17	0.15
3750	0.13	0.14	0.19	0.20	0.17
4000	0.14	0.14	0.21	0.22	0.19
4250	0.15	0.14	0.24	0.28	0.21
4500	0.17	0.15	0.26	0.32	0.24
4750	0.18	0.16	0.29	0.37	0.26
5000	0.20	0.16	0.34	0.43	0.29
5250	0.22	0.16	0.37	0.47	0.32
5500	0.23	0.18	0.44	0.54	0.34
5750	0.25	0.19	0.49	0.59	0.37
6000	0.27	0.20	0.54	0.64	0.40

BLOWER DATA

CEILING DIFFUSERS AIR RESISTANCE - in. w.g.

Size	RTD11 Step-Down Diffuser				FD11 Flush Diffuser
	Air Volume cfm	2 Ends Open	1 Side, 2 Ends Open	All Ends & Sides Open	
092	2400	0.21	0.18	0.15	0.14
	2600	0.24	0.21	0.18	0.17
	2800	0.27	0.24	0.21	0.20
	3000	0.32	0.29	0.25	0.25
	3200	0.41	0.37	0.32	0.31
	3400	0.50	0.45	0.39	0.37
	3600	0.61	0.54	0.48	0.44
	3800	0.73	0.63	0.57	0.51
102 & 120	3600	0.36	0.28	0.23	0.15
	3800	0.40	0.32	0.26	0.18
	4000	0.44	0.36	0.29	0.21
	4200	0.49	0.40	0.33	0.24
	4400	0.54	0.44	0.37	0.27
	4600	0.60	0.49	0.42	0.31
	4800	0.65	0.53	0.46	0.35
	5000	0.69	0.58	0.50	0.39
150	5200	0.75	0.62	0.54	0.43
	4200	0.22	0.19	0.16	0.10
	4400	0.28	0.24	0.20	0.12
	4600	0.34	0.29	0.24	0.15
	4800	0.40	0.34	0.29	0.19
	5000	0.46	0.39	0.34	0.23
	5200	0.52	0.44	0.39	0.27
	5400	0.58	0.49	0.43	0.31
5600	0.64	0.54	0.47	0.35	
5800	0.70	0.59	0.51	0.39	

CEILING DIFFUSER AIR THROW DATA

Size	Air Volume cfm	¹ Effective Throw Range	
		RTD11 Step-Down	FD11 Flush
		ft.	ft.
092	2600	24 - 29	19 - 24
	2800	25 - 30	20 - 28
	3000	27 - 33	21 - 29
	3200	28 - 35	22 - 29
	3400	30 - 37	22 - 30
102, 120	3600	25 - 33	22 - 29
	3800	27 - 35	22 - 30
	4000	29 - 37	24 - 33
	4200	32 - 40	26 - 35
	4400	34 - 42	28 - 37
150	5600	39 - 49	28 - 37
	5800	42 - 51	29 - 38
	6000	44 - 54	40 - 50
	6200	45 - 55	42 - 51
	6400	46 - 55	43 - 52
6600	47 - 56	45 - 56	

¹ Throw is the horizontal or vertical distance an air stream travels on leaving the outlet or diffuser before the maximum velocity is reduced to 50 ft. per minute. Four sides open.

ELECTRICAL DATA**7.5 TON**

Model		ZGD092S5T		
¹ Voltage - 60hz		208/230V - 3 Ph	460V - 3 Ph	575V - 3 Ph
Compressor 1 (Non-Inverter)	Rated Load Amps	12.4	6.5	4.8
	Locked Rotor Amps	93	60	41
Compressor 2 (Non-Inverter)	Rated Load Amps	12.8	5.1	4.5
	Locked Rotor Amps	97.5	44.3	27.1
Service Outlet 115V GFI (amps)		15	15	20
Outdoor Fan Motors (2)	Full Load Amps (2 Non-ECM)	3	1.5	1.2
	Total	6	3	2.4
Power Exhaust (2) 0.33 HP	Full Load Amps	2.4	1.3	1
	Total	4.8	2.6	2
Indoor Blower Motor	Horsepower	2	2	2
	Full Load Amps	7.5	3.4	2.7
² Maximum Overcurrent Protection (MOCP)	Unit Only	50	25	15
	With (2) 0.33 HP Power Exhaust	50	25	20
³ Minimum Circuit Ampacity (MCA)	Unit Only	40	19	15
	With (2) 0.33 HP Power Exhaust	45	22	17

ELECTRICAL ACCESSORIES

Disconnect	39U73	39U73	39U73
------------	-------	-------	-------

Disconnect - **39U73** - 80A

NOTE - All units have a minimum Short Circuit Current Rating (SCCR) of 5000 amps.

¹ Extremes of operating range are plus and minus 10% of line voltage.² HACR type breaker or fuse.³ Refer to National or Canadian Electrical Code manual to determine wire, fuse and disconnect size requirements.**ELECTRICAL DATA****8.5 TON**

Model		ZGD102S5T		
¹ Voltage - 60Hz		208/230V - 3 Ph	460V - 3 Ph	575V - 3 Ph
Compressor 1 (Non-Inverter)	Rated Load Amps	12.4	6.5	4.8
	Locked Rotor Amps	93	60	41
Compressor 2 (Non-Inverter)	Rated Load Amps	12.2	6.4	5.1
	Locked Rotor Amps	120	50	41
Outdoor Fan Motors (2)	Full Load Amps (2 Non-ECM)	3	1.5	1.2
	Total	6	3	2.4
Service Outlet 115V GFI (amps)		15	15	20
Power Exhaust (2) 0.33 HP	Full Load Amps	2.4	1.3	1
	Total	4.8	2.6	2
Indoor Blower Motor	Horsepower	2	2	2
	Full Load Amps	7.5	3.4	2.7
² Maximum Overcurrent Protection (MOCP)	Unit Only	50	25	20
	With (2) 0.33 HP Power Exhaust	50	25	20
³ Minimum Circuit Ampacity (MCA)	Unit Only	39	20	16
	With (2) 0.33 HP Power Exhaust	44	23	18

ELECTRICAL ACCESSORIES

Disconnect	39U73	39U73	39U73
------------	-------	-------	-------

Disconnect - **39U73** - 80A

NOTE - All units have a minimum Short Circuit Current Rating (SCCR) of 5000 amps.

¹ Extremes of operating range are plus and minus 10% of line voltage.² HACR type breaker or fuse.³ Refer to National or Canadian Electrical Code manual to determine wire, fuse and disconnect size requirements.

ELECTRICAL DATA**10 TON**

Model		ZGD120S5M		
¹ Voltage - 60hz		208/230V - 3 Ph	460V - 3 Ph	575V - 3 Ph
Compressor 1 (Non-Inverter)	Rated Load Amps	12.4	6.5	4.8
	Locked Rotor Amps	93	60	41
Compressor 2 (Non-Inverter)	Rated Load Amps	16	7.1	6.4
	Locked Rotor Amps	156	69	47.8
Outdoor Fan Motors (2)	Full Load Amps (2 Non-ECM)	3	1.5	1.2
	Total	6	3	2.4
Service Outlet 115V GFI (amps)		15	15	20
Power Exhaust (2) 0.33 HP	Full Load Amps	2.4	1.3	1
	Total	4.8	2.6	2
Indoor Blower Motor	Horsepower	3	3	3
	Full Load Amps	10.6	4.8	3.9
² Maximum Overcurrent Protection (MOCP)	Unit Only	60	30	25
	With (2) 0.33 HP Power Exhaust	60	30	25
³ Minimum Circuit Ampacity (MCA)	Unit Only	49	24	20
	With (2) 0.33 HP Power Exhaust	54	26	22

ELECTRICAL ACCESSORIES

Disconnect	39U73	39U73	39U73
------------	-------	-------	-------

Disconnect - **39U73** - 80A

NOTE - All units have a minimum Short Circuit Current Rating (SCCR) of 5000 amps.

¹ Extremes of operating range are plus and minus 10% of line voltage.² HACR type breaker or fuse.³ Refer to National or Canadian Electrical Code manual to determine wire, fuse and disconnect size requirements.**ELECTRICAL DATA****12.5 TON**

Model		ZGD150S5M		
¹ Voltage - 60hz		208/230V - 3 Ph	460V - 3 Ph	575V - 3 Ph
Compressor 1 (Non-Inverter)	Rated Load Amps	19.2	9.1	6.2
	Locked Rotor Amps	162	70.8	58.2
Compressor 2 (Non-Inverter)	Rated Load Amps	22.4	9.1	7.2
	Locked Rotor Amps	166	74.6	54
Outdoor Fan Motors (2)	Full Load Amps (2 Non-ECM)	3	1.5	1.2
	Total	6	3	2.4
Service Outlet 115V GFI (amps)		15	15	20
Power Exhaust (2) 0.33 HP	Full Load Amps	2.4	1.3	1
	Total	4.8	2.6	2
Indoor Blower Motor	Horsepower	5	5	5
	Full Load Amps	16.7	7.6	6.1
² Maximum Overcurrent Protection (MOCP)	Unit Only	90	40	30
	With (2) 0.33 HP Power Exhaust	90	40	30
³ Minimum Circuit Ampacity (MCA)	Unit Only	70	32	24
	With (2) 0.33 HP Power Exhaust	75	34	26

ELECTRICAL ACCESSORIES

Disconnect	39U73	39U73	39U73
------------	-------	-------	-------

Disconnect - **39U73** - 80A

NOTE - All units have a minimum Short Circuit Current Rating (SCCR) of 5000 amps.

¹ Extremes of operating range are plus and minus 10% of line voltage.² HACR type breaker or fuse.³ Refer to National or Canadian Electrical Code manual to determine wire, fuse and disconnect size requirements.**FIELD WIRING NOTES**

- For use with copper wiring only
- Field wiring not furnished
- All wiring must conform to NEC or CEC and local electrical codes
- For specific wiring information, please refer to the installation instructions

OUTDOOR SOUND DATA

Size	Octave Band Sound Power Levels dBA, re 10 ⁻¹² Watts - Center Frequency - Hz							¹ Sound Rating Number dBA
	125	250	500	1000	2000	4000	8000	
092, 102	72	74	79	80	76	70	63	84
120	76	73	82	80	75	74	73	90
150	76	81	87	86	80	77	76	91

¹ Sound Rating Number according to ARI Standard 270-2008. Sound Rating Number is the overall A-Weighted Sound Power Level, (LWA), dB (100 Hz to 10,000 Hz).

UNIT CLEARANCES

UNIT WITH ECONOMIZER

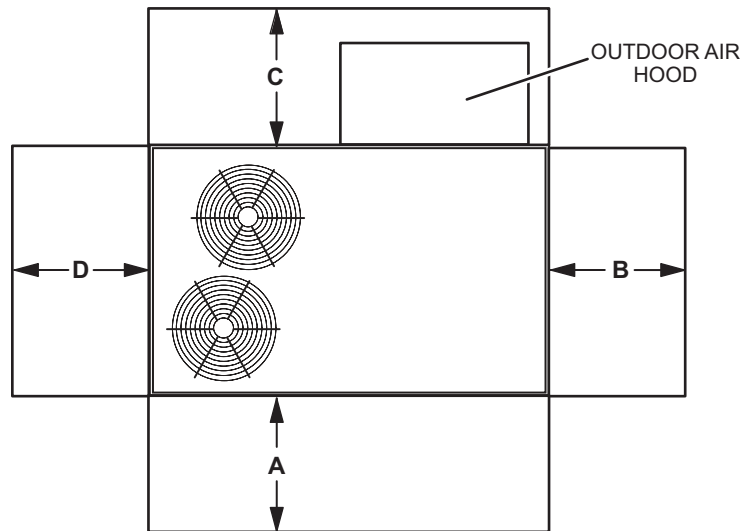

¹ Unit Clearance	A		B		C		D		Top Clearance
	in.	mm	in.	mm	in.	mm	in.	mm	
Service Clearance	60	1524	36	914	36	914	60	1524	Unobstructed
Clearance to Combustibles	36	914	1	25	1	25	1	25	
Minimum Operation Clearance	36	914	36	914	36	914	36	914	

NOTE - Entire perimeter of unit base requires support when elevated above the mounting surface.

¹ Service Clearance - Required for removal of serviceable parts.

Clearance to Combustibles - Required for clearance to combustible material.

Minimum Operation Clearance - Required clearance for proper unit operation.

WEIGHT DATA

Size	Net		Shipping	
	lbs.	kg	lbs.	kg
092S Base Unit	841	382	926	420
092S Max. Unit	992	450	1077	489
102S Base Unit	841	382	926	420
102S Max. Unit	992	450	1077	489
120S Base Unit	881	400	966	438
120S Max. Unit	1032	468	1117	507
150S Base Unit	971	440	1056	479
150S Max. Unit	1112	532	1207	548

FACTORY / FIELD INSTALLED OPTIONS AND ACCESSORIES - NET WEIGHTS

Description	lbs.	kg	
ECONOMIZER / OUTDOOR AIR / EXHAUST			
Economizer			
Downflow with Barometric Relief Dampers and Hoods	90	41	
Horizontal with Barometric Relief Dampers and Hoods	95	43	
Horizontal Low Profile Barometric Relief Dampers with Hood	8	4	
Outdoor Air Dampers With Hood			
Motorized	44	20	
Manual	27	12	
Power Exhaust			
Downflow	60	27	
Horizontal	41	19	
GAS HEAT EXCHANGER (NET WEIGHT)			
Medium Heat (adder over standard heat)	9	4	
High Heat (adder over standard heat)	32	15	
COMBINATION COIL/HAIL GUARDS			
All models	50	23	
ROOF CURBS			
Hybrid Roof Curbs, Downflow			
8 in. height	79	36	
14 in. height	104	47	
18 in. height	120	54	
24 in. height	145	66	
CEILING DIFFUSERS			
Step-Down	RTD11-95S	118	54
	RTD11-135S	135	61
	RTD11-185S	168	76
Flush	FD11-95S	118	54
	FD11-135S	135	61
	FD11-185S	168	76

DIMENSIONS

UNIT

Model No.	CORNER WEIGHTS																CENTER OF GRAVITY							
	AA				BB				CC				DD				EE				FF			
	Base		Max.		Base		Max.		Base		Max.		Base		Max.		Base		Max.		Base		Max.	
	lbs.	kg	lbs.	kg	lbs.	kg	lbs.	kg	lbs.	kg	lbs.	kg	lbs.	kg	lbs.	kg	in.	mm	in.	mm	in.	mm	in.	mm
092S	264	120	305	138	195	88	241	109	197	89	233	106	266	121	295	134	47.5	1207	48.5	1232	25.5	648	26.5	673
102S	264	120	305	138	195	88	241	109	197	89	233	106	266	121	295	134	47.5	1207	48.5	1232	25.5	648	26.5	673
120S	275	125	316	143	204	92	250	113	205	93	242	110	278	126	306	139	47.5	1207	48.5	1232	25.5	648	26.5	673
150S	301	137	341	155	223	101	270	123	224	102	261	118	304	138	330	150	47.5	1207	48.5	1232	25.5	648	26.5	673

Base Unit - The unit with NO OPTIONS.

Max. Unit - The unit with ALL OPTIONS Installed. (Economizer, etc.)

BOTTOM POWER ENTRY

Holes required for Optional Bottom Power Entry Kit

	Threaded Conduit Fittings (Provided in Kit)	Wire Use	Hole Diameter Required in Unit Base (Max.)
A	¹ 1/2	ACC	7/8 (23)
B	1/2	24V	7/8 (23)
C	1-1/4	POWER	1-3/4 (44)
D	¹ 3/4	AUX	1-3/4 (44)

¹ 1 Field provided.

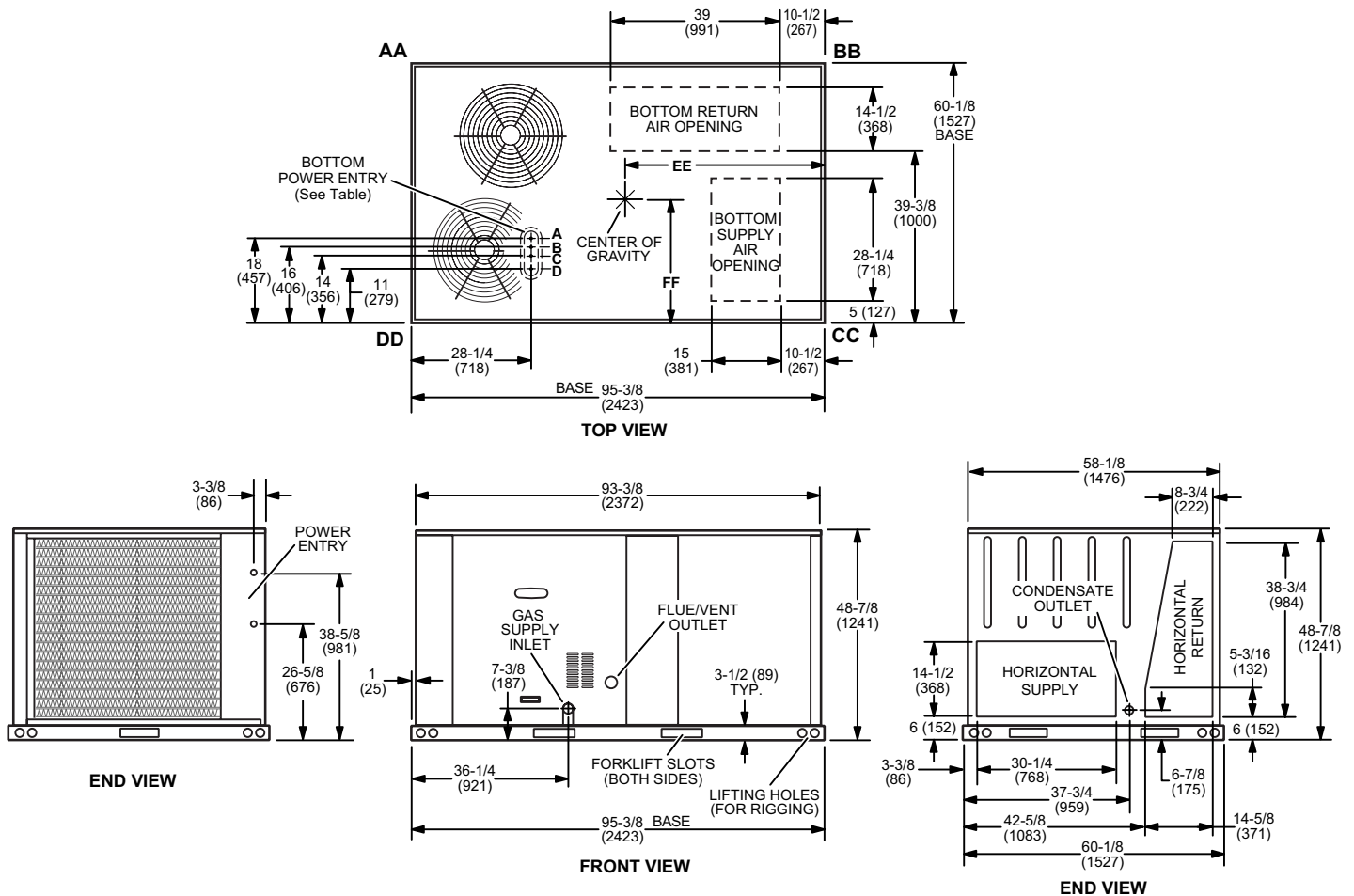

**OUTDOOR AIR HOOD DETAIL FOR OPTIONAL DOWNFLOW ECONOMIZER
(Downflow Applications)**

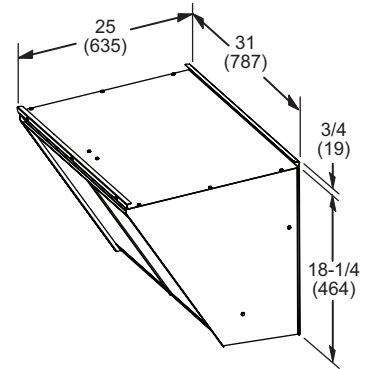
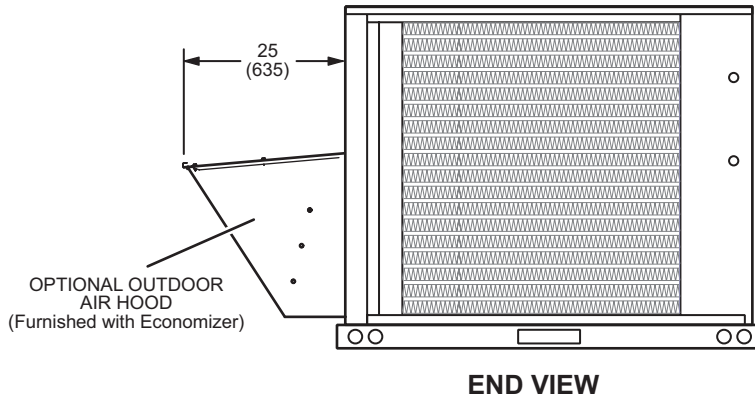

**OUTDOOR AIR DAMPER HOOD DETAIL FOR OPTIONAL MANUAL OR MOTORIZED OUTDOOR AIR DAMPERS
(Downflow or Horizontal Applications)**

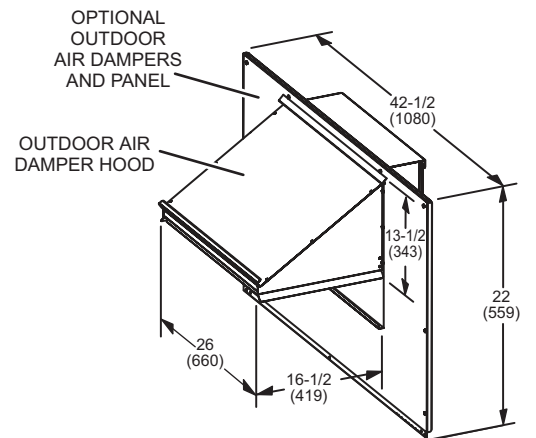
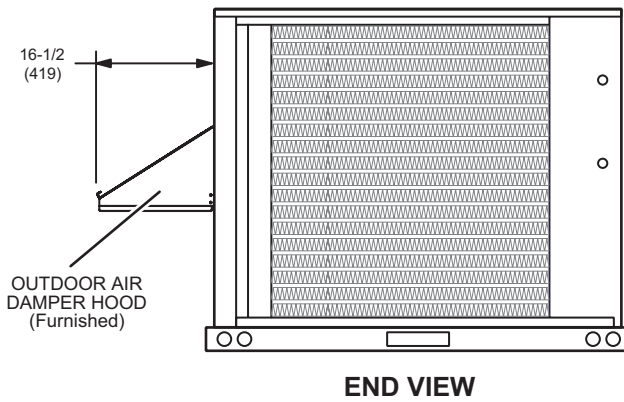

**OUTDOOR AIR HOOD DETAIL WITH OPTIONAL HORIZONTAL ECONOMIZER AND BAROMETRIC RELIEF DAMPERS
(Horizontal Applications)**

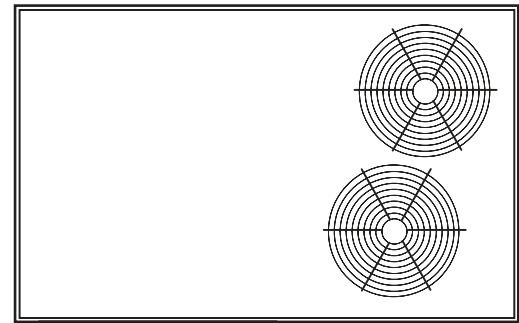

OUTDOOR AIR/
BAROMETRIC
RELIEF HOOD
(Furnished with
Economizer)

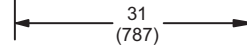

TOP VIEW

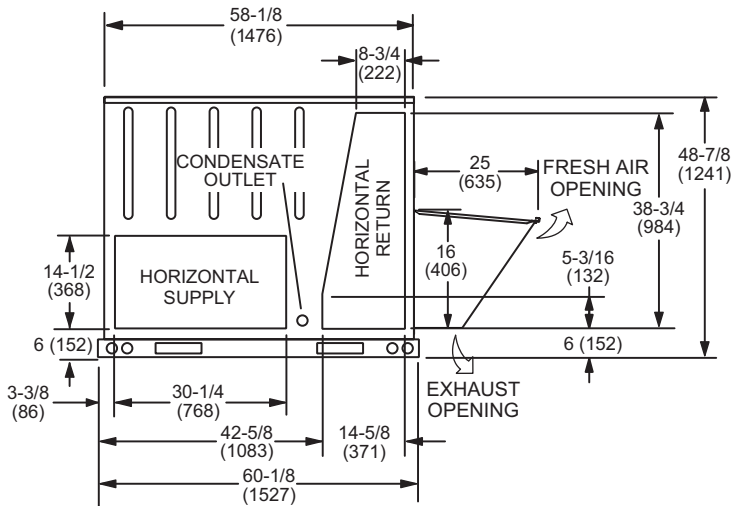

END VIEW

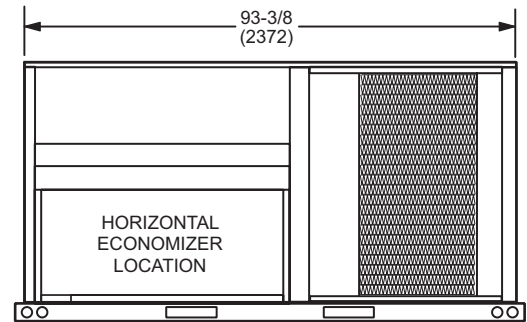

BACK VIEW

Note - Supply and Return Air Ducts must be supported.

HYBRID CURBS - DOUBLE DUCT OPENING

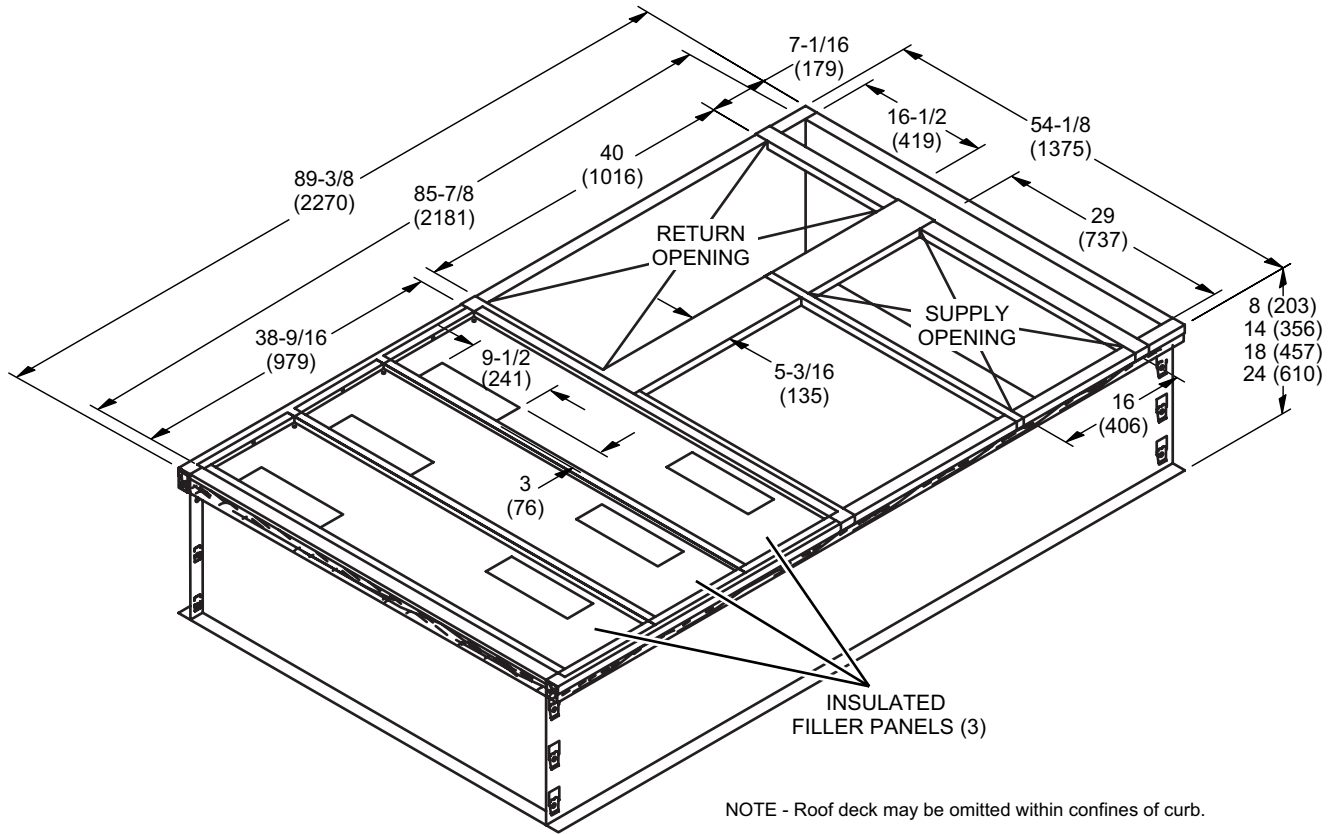

TYPICAL FLASHING DETAIL FOR ROOF CURB

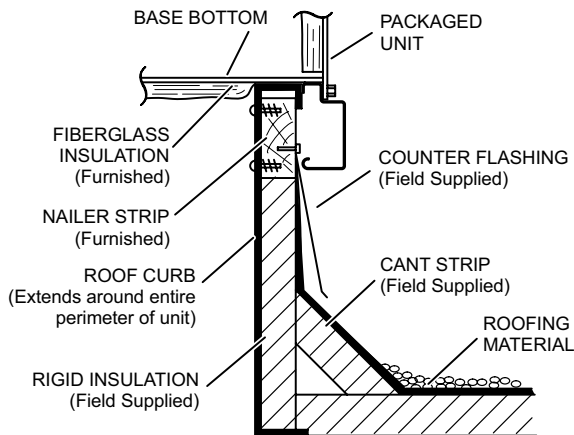

DETAIL ROOF CURB

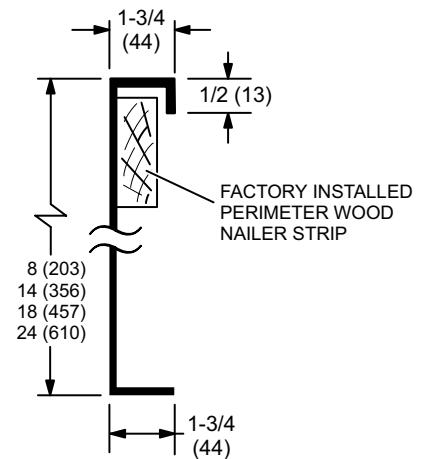

COMBINATION CEILING SUPPLY AND RETURN DIFFUSERS

STEP-DOWN CEILING DIFFUSER

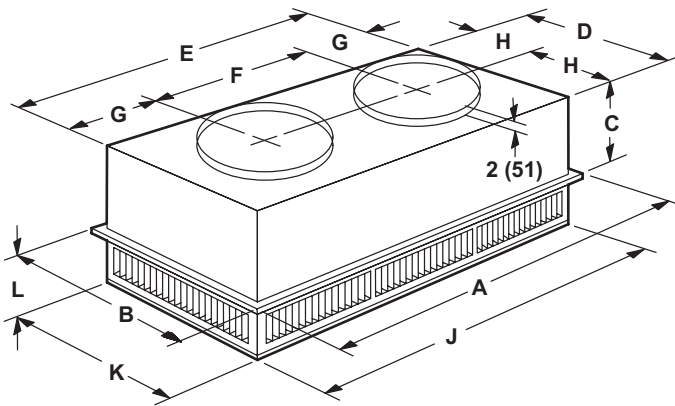

FLUSH CEILING DIFFUSER

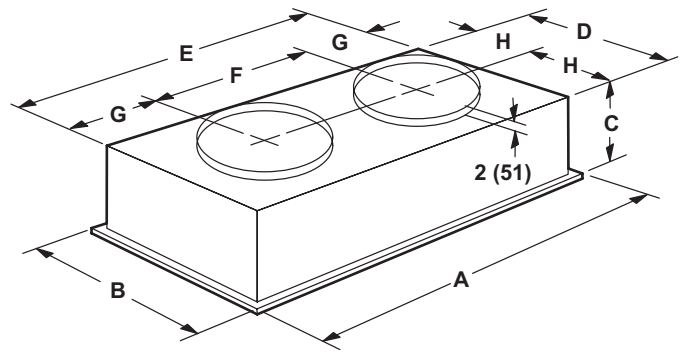

Model		RTD11-95S
A	in.	47-5/8
	mm	1159
B	in.	29-5/8
	mm	752
C	in.	14-3/8
	mm	365
D	in.	27-1/2
	mm	699
E	in.	45-1/2
	mm	1158
F	in.	22-1/2
	mm	572
G	in.	11-1/2
	mm	292
H	in.	13-3/4
	mm	349
J	in.	45-1/2
	mm	1156
K	in.	27-1/2
	mm	699
L	in.	8-1/8
	mm	206
Duct Size	in.	20 round
	mm	508 round

Model		FD11-95S
A	in.	47-5/8
	mm	1159
B	in.	29-5/8
	mm	752
C	in.	16-5/8
	mm	422
D	in.	27
	mm	686
E	in.	45
	mm	1143
F	in.	22-1/2
	mm	572
G	in.	11-1/4
	mm	286
H	in.	13-1/2
	mm	343
Duct Size	in.	20 round
	mm	508 round

COMBINATION CEILING SUPPLY AND RETURN DIFFUSERS

STEP-DOWN CEILING DIFFUSER

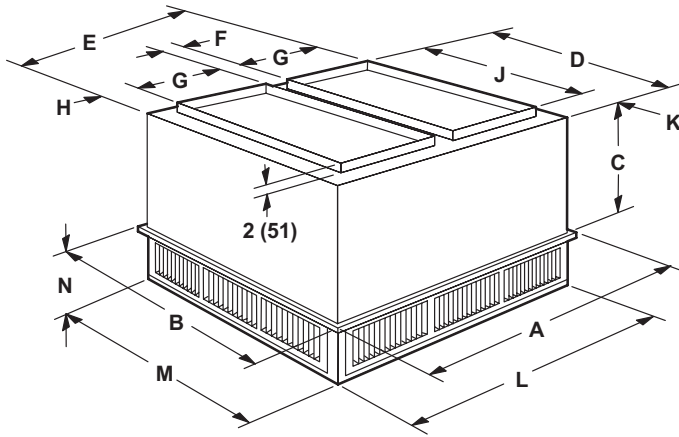

FLUSH CEILING DIFFUSER

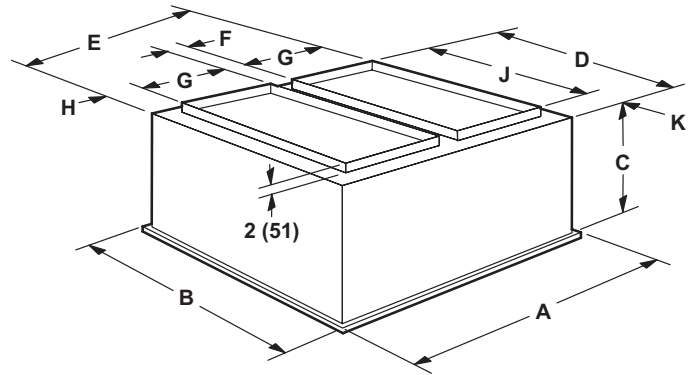

Model		RTD11-135S	RTD11-185S
A	in.	47-5/8	47-5/8
	mm	1210	1210
B	in.	35-5/8	47-5/8
	mm	905	1210
C	in.	20-5/8	24-5/8
	mm	524	625
D	in.	33-1/2	45-1/2
	mm	851	1156
E	in.	45-1/2	45-1/2
	mm	1156	1156
F	in.	4-1/2	4-1/2
	mm	114	114
G	in.	18	18
	mm	457	457
H	in.	2-1/2	2-1/2
	mm	64	64
J	in.	28	36
	mm	711	914
K	in.	2-3/4	4-3/4
	mm	70	121
L	in.	45-1/2	45-1/2
	mm	1156	1156
M	in.	33-1/2	45-1/2
	mm	851	1156
N	in.	9-1/8	10-1/8
	mm	232	257
Duct Size	in.	18 x 28	18 x 36
	mm	457 x 711	457 x 914

Model		FD11-135S	FD11-185S
A	in.	47-5/8	47-5/8
	mm	1210	1210
B	in.	35-5/8	47-5/8
	mm	905	1210
C	in.	23-1/4	29-1/4
	mm	591	743
D	in.	33	45
	mm	838	1143
E	in.	45	45
	mm	1143	1143
F	in.	4-1/2	4-1/2
	mm	114	114
G	in.	18	18
	mm	457	457
H	in.	2-1/4	2-1/4
	mm	57	57
J	in.	28	36
	mm	711	914
K	in.	2-1/2	4-1/2
	mm	64	114
Duct Size	in.	18 x 28	18 x 36
	mm	457 x 711	457 x 914

REVISIONS

Sections	Description of Change
Approvals	Updated.
Options / Accessories	Added Smoke Detectors, GFI Outlets and Disconnects as options.



Visit us at www.Lennox.com

For the latest technical information, www.LennoxCommercial.com

Contact us at 1-800-4-LENNOX

NOTE - Due to Lennox' ongoing commitment to quality, Specifications, Ratings and Dimensions subject to change without notice and without incurring liability. Improper installation, adjustment, alteration, service or maintenance can cause property damage or personal injury. Installation and service must be performed by a qualified installer and servicing agency.

©2026 Lennox Industries, Inc.