



LENNOX® CORE UNIT CONTROLLER SETUP GUIDE

508111-01
1/2021

CORE

CONTROL SYSTEM

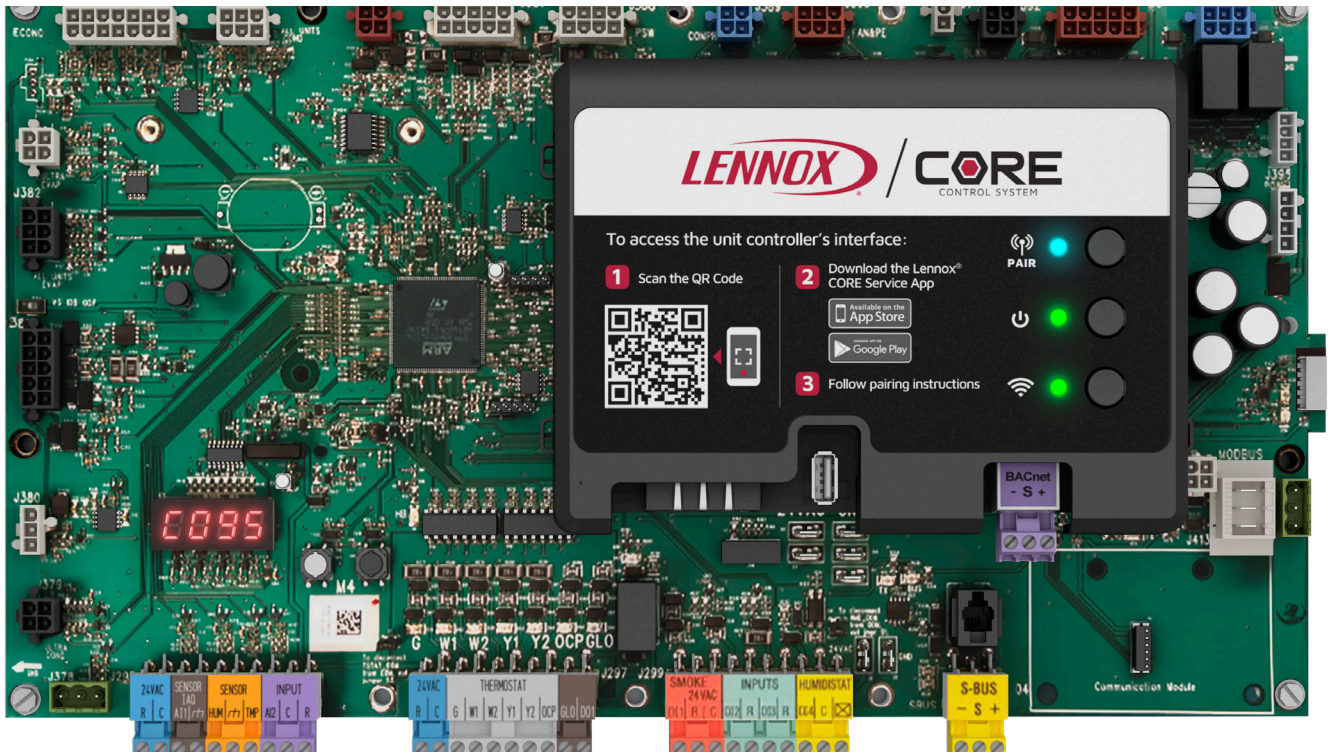

WARNING

Improper installation, adjustment, alteration, service or maintenance can cause property damage, personal injury or loss of life.

Installation and service must be performed by a licensed professional HVAC installer (or equivalent) or service agency



0121

508111-01

Table of Contents

1. CORE Unit Controller Overview.....	3	14.2. Service Relays.....	40
1.1. Lennox® CORE Service App - Android or iOS Device Minimum System Requirements.....	3	15. CORE Control System Unit Parameters.....	52
1.2. Additional Features.....	3	16. CORE Control System Inputs and Outputs	78
1.3. Configurable Sequences of Operation.....	3	16.1. CORE Unit Controller (A55) Input/Outputs.....	78
1.4. Component Protection / Unit Safeguards.....	3	16.2. C4 Control (A178).....	86
1.5. Control Methods / Interfaces.....	3	16.3. DSI Board (A3).....	88
1.6. Lennox CORE Unit Controller - Connections, Inputs / Outputs, Jumpers, and LEDs Locations...4		16.4. W4 Control.....	91
2. W4 Wireless Controller - Connections, Buttons and LEDs	7	17. Quick Start Guide.....	92
2.1. Wireless Gateway	8	18. Wiring Diagrams.....	93
2.2. CORE Service App.....	8		
2.3. Wireless Sensor.....	8		
2.4. Wireless Repeater	8		
2.5. Cloud Firmware Updates	9		
3. Network Types	9		
4. Unit Operation	9		
5. CORE Service App Menu Selection Overview	9		
6. Pairing CORE Service App to CORE Unit Controller	10		
7. System Overview - Room Sensor Mode.....	10		
8. Active Alarms.....	10		
9. CORE Service App General Menu + User Preference.....	10		
10. CORE Service App RTU Menu.....	10		
10.1. Setup.....	10		
10.2. Data	20		
10.3. Service.....	24		
10.4. Settings.....	28		
11. Special Equipment Configurations.....	30		
11.1. Thermal Protection Switches (S5, S8, S31 and S180)	30		
11.2. Blower Operation with Effective Occupancy	30		
11.3. Enabling Economizer and Settings	32		
11.4. Free Cooling Compressor Lockout Mode and Low Ambient Set Point.....	32		
11.5. Demand Control Ventilation	35		
11.6. Determining Indoor Air Quality Inputs	37		
11.7. BACNET	37		
11.8. Abbreviations	38		
12. Parts and Kits	39		
13. Service Report Example	39		
14. Alarms	40		
14.1. Phase - Voltage Detection	40		

1. CORE Unit Controller Overview

For all available CORE Control System documentation, go to the Lennox Commercial website.

www.lennoxcommercial.com

The Lennox Core Unit Controller is a multi-processor-based controller. Standard with all Model L™ rooftop units, integrates key technologies that lower installation costs, drive system efficiency, and protect your investments. The CORE Unit Controller is a microprocessor-based controller that provides flexible control of all unit functions.

Lennox® CORE Service App Connectivity

- Setup menu insures proper installation and simplified setup of the rooftop unit
- Detailed data readout updates sensor values in real time and allows trending
- Unit self-test verifies individual critical component and system performance
- Economizer test function ensures economizer is operating correctly

1.1. Lennox® CORE Service App - Android or iOS Device Minimum System Requirements

- Android hardware requires 2GB RAM and 2GHz Core processor. Tablets are supported.
- Minimum Android 6.0 (Marshmallow) or higher. Recommend Android 10 and Apple products require IOS version 11 or higher.

1.2. Additional Features

- Built-In 7-segment display (four character positions) the unit status and active alarms for easy troubleshooting
- Buttons for test and clearing delays
- SmartWire™ System with keyed and removable screw terminals ensure correct field wiring
- Built-in BACnet IP and MS/TP allow open integration to building management systems
- Two-port Ethernet Switch enables daisy chaining for BACnet IP and automatic firmware updates

NOTE: *Unit Internet Connection required for firmware update only and not for BACnet IP.*

- Profile setup copies key settings between units with the same configuration to reduce setup time
- USB port allows a technician to download and transfer unit information to help verify service was performed
- USB software updates on the CORE™ Unit Controller enhance functionality without the need to change components

1.3. Configurable Sequences of Operation

- Single-Zone VAV (Discharge Control) Cooling (With room sensor or 24V DDC)
- Three Cooling Stages (With compatible thermostat or DDC / additional relay)

- Four Heating Stages using a room sensor (up to two with thermostat / DDC Controls)
- Four stages in VAV/Discharge Air Control with thermostat input to W1
- Multi-Zone VAV (Discharge Control) Heating and Cooling
- Economizer Control Options (See Economizer / Exhaust Air / Outdoor Air sections)
- Exhaust Fan Control Modes for fresh air damper position
- Configurable morning warm-up and morning cool-down
- Night Setback Mode
- Fresh Air Tempering for improved space temperature control during ventilation'
- Demand Control Ventilation
- Low Ambient Controls for operation down to 0°F
- Humiditrol®+ Operation (Variable Capacity Hot-Gas Reheat)
- Enhanced Dehumidification (Latent Demand Control without reheat)

1.4. Component Protection / Unit Safeguards

- Compressor Time-Off Delay
- Adjustable Blower On/Off Delay
- Return Air Temperature Limit Control
- Safety Switch Input allows Controller to respond to a external safety switch trip
- Service Relay Output
- Thermostat Bounce Delay
- Smoke Alarm Mode has four choices (unit off, positive pressure, negative pressure, purge)
- "Strike Three" Protection
- Gas Valve Time Delay Between First and Second Stage
- Minimum Compressor Run Time

1.5. Control Methods / Interfaces

- DDC and 24V Thermostat
- BACnet (MS/TP) and IP
- LONTalk (Factory & Field Option)
- Lennox S-BUS
- Compatibility with Lennox Wireless Zone Sensors
- Zone Temperature Sensor input
- Dehumidistat & Humidity Sensor inputs
- Indoor Air Quality Inputs (2)
- One IAQ input is report only.
- Built-in Control Parameter Defaults
- Permanent Diagnostic Code Storage
- Field Adjustable Control Parameters (Over 200 settings)
- Dirty Filter Switch Input

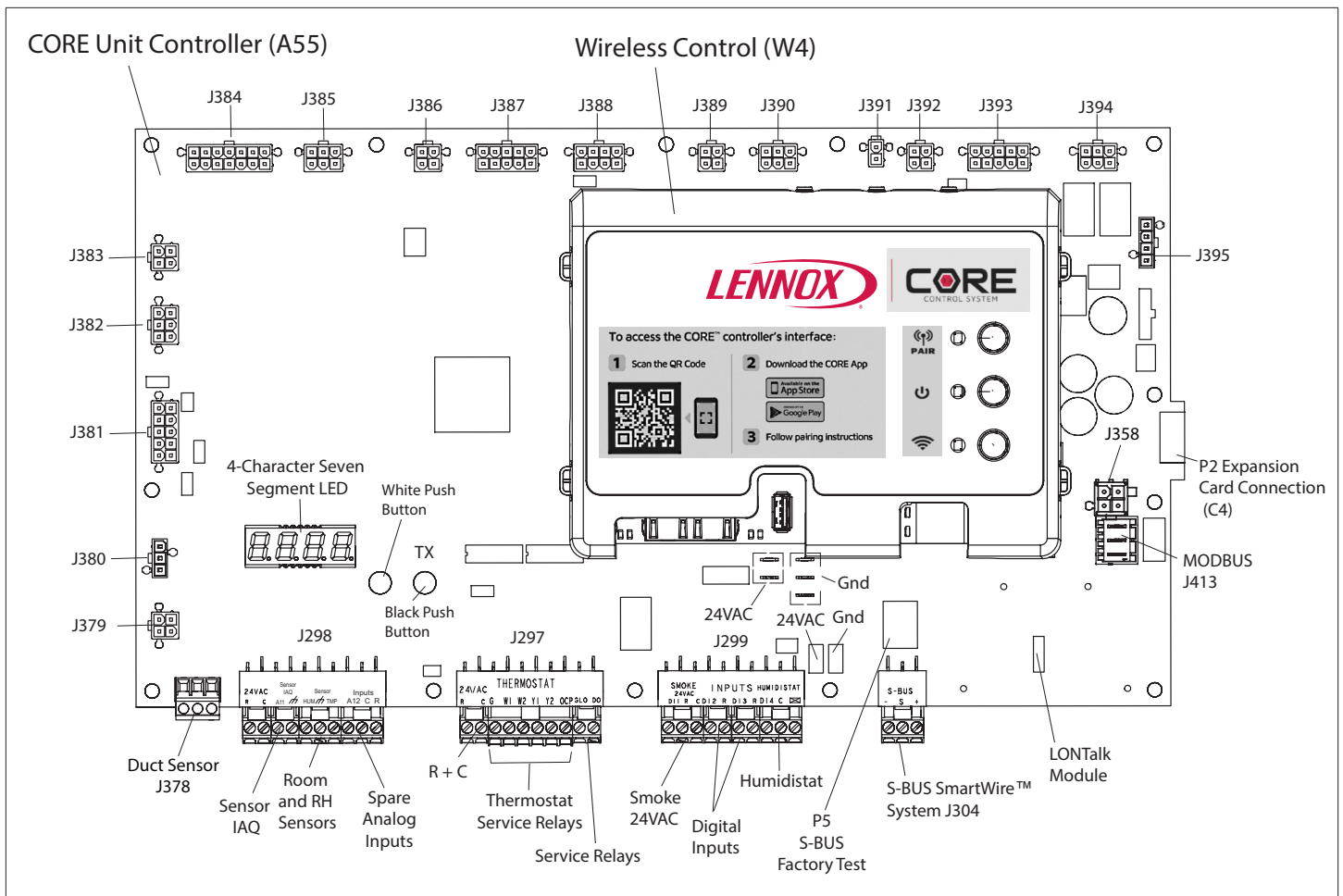

Figure 1. Lennox CORE Unit Controller Interfaces and LEDs Locations

- LED Indicators

NOTE: CORE™ Control System features vary with the type of rooftop unit in which the control is installed.

1.6. Lennox CORE Unit Controller - Connections, Inputs / Outputs, Jumpers, and LEDs Locations

THERMOSTAT COMMON ISOLATION - TSTAT_COM Jumper

Thermostat (TSTAT) sensor commons are located on connector P298 and may be isolated if they are powered remotely. Remove jumper.

This jumper is located to the left of P297 connector. This jumper would be removed only in unique situations where the device supplying the thermostat signals to the CORE Unit Controller has its own power source and does not share a common reference voltage with the CORE unit controller. Otherwise the jumper would remain installed across both pins, as shipped from the factory.

A. HUMIDISTAT COMMON ISOLATION -: HMD_COM Jumper

The humidity (HUM) sensor commons are located on connector P298 and may be isolated if they are powered remotely. Remove jumper. This jumper is located to the right of P299 connector. This jumper would be removed only in unique situations where the device supplying the thermostat/humidistat signals to the CORE Unit Controller has its own power source and does not share a common reference voltage with the CORE Unit Controller. Otherwise the jumper

would remain installed across both pins, as shipped from the factory.

B. W4 CONTROL - USB FLASH DRIVE INTERFACE USAGE

The W4 Control uses a USB type A interface. This USB port is used for verifying service, downloading reports, transferring unit profiles and performing firmware updates.

On-site data collection requires use of either a USB flash drive or download and shared from the CORE Service App. Data written to the drive includes date, time, serial number, catalog number, basic data, error code buffer, and unit configuration.

C. S-BUS (SMARTWIRE™) (J304)

This is the L-connection interface. This is a R485 network connection with other devices (NCP, comfort sensors, other RTU, etc.).

D. MODBUS CONNECTION (J413)

This is a TIA-485 serial line over MODBUS (messaging structure) communication. This connection is used for multiple components.

E. CORE UNIT CONTROLLER LED INDICATORS

NOTE: See “g. Local Interface - four character seven segment LED - Status Codes” on page 6 for further information.

Table 1. LED Operation Indicators

LED	Status	Indication	Meaning
Heartbeat (HB) (D33)	Green	Slow Flash	Normal Operation
	Green	Fast Flash	Boot loader / firmware update mode
	No light	Steady Off	No voltage to M3 board or defective board
	Green	Steady On	Unit in configuration / test mode (not in normal mode)
S-BUS / PC Connection (D70 and D71)	BUS (green)	Flickering ON	Network traffic present
	TX (yellow)	Flickering ON	Unit controller is transmitting
Thermostat Input	Yellow	Indicates a thermostat demand	G - Blower on
			W1 - First-Stage Heating
			W2 - Second -Stage Heating
			Y1 - First-Stage Cooling
			Y2 - Second-Stage Cooling
			OCP - Occupied
GLO - Global input			
MODBUS	Two LEDs that indicate transmit (TX) and receive (RX) activity.		
<p>Slow Flash = 1 second on; 1 second off. Fast Flash = ½ second on; ½ second off. A “flickering” LED flashes significantly faster than a “fast flash”.</p>			
NOTE: LEDs are energized by 24VAC thermostat inputs.			

F. LOCAL INTERFACE - PUSH BUTTONS AND HEART BEAT

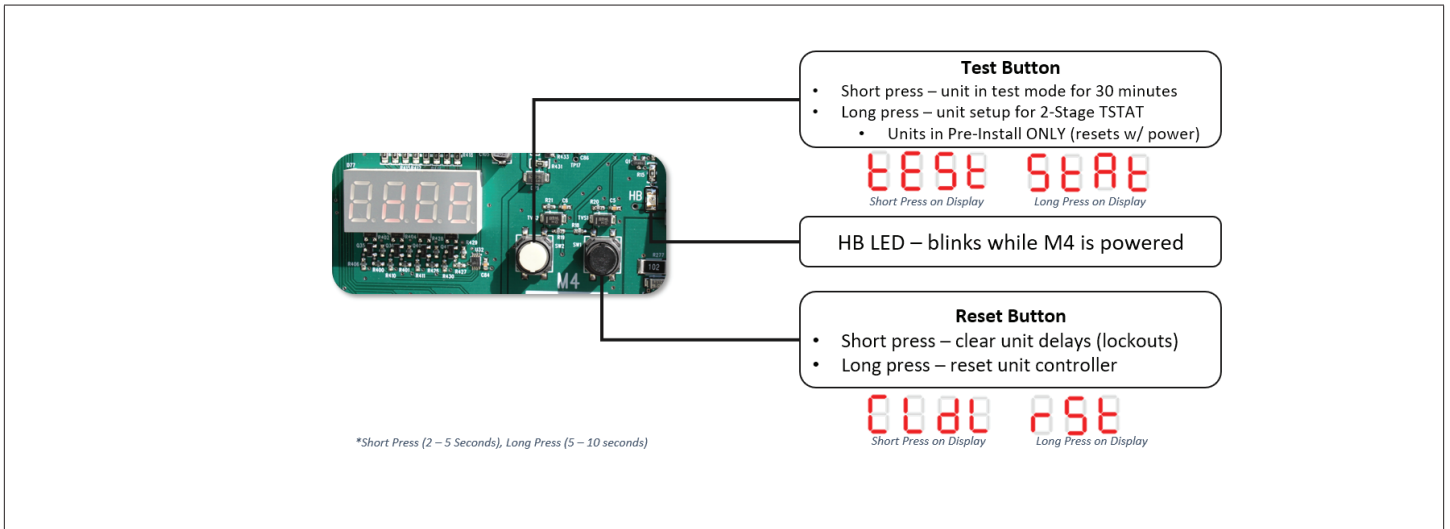

Figure 2. Push Buttons and Heart Beat

G. LOCAL INTERFACE - FOUR CHARACTER SEVEN SEGMENT LED - STATUS CODES

Table 2. Status Codes

Status Code	Definition
PnSt	Pre-Install
A173	Smoke
Lout	Controller Lockout
Error	Off On Alarm
d300	Delay up to 5 minutes
d020	Delay up to 20 seconds
dhUm	Dehumidification
ShEd	Compressor Load Shedding
Prht	Morning Warmup
Strt	Start up
FAH	Fresh Air Heating
H050	Heating (50%)
PrCL	Pre-Cool
CEoP	Cool + Max Open Economizer
CE10	Cool + Modulate Economizer (10%)
FrCL	Free Cooling
FAC	Fresh Air Cooling
C078	Cooling (78%)
6715	Blower On - OAS (71%)
623	Blower On (23%)
ioAS	No Demand - OAS
idLE	No Demand

2. W4 Wireless Controller - Connections, Buttons and LEDs

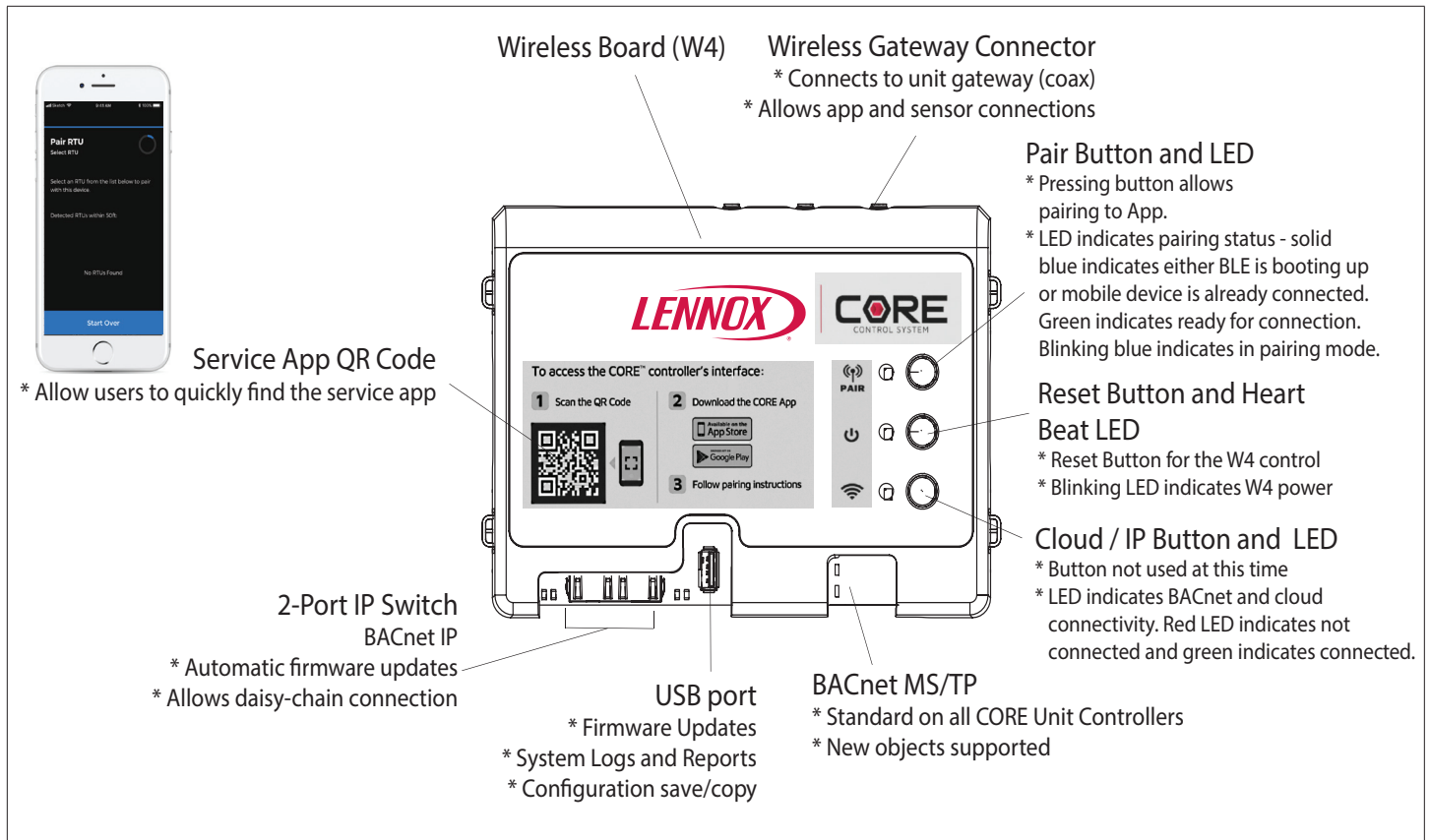

Figure 3. W4 Controller Interfaces

2.1. Wireless Gateway

- Return mount antenna that enables wireless connections.
- Plenum-rated BLE antenna
- Boosts signal from CORE Unit Controller to CORE Service App
 - > Wireless room sensors.
 - > Factory installed placement allows for use in vertical and horizontal applications.
- Return air mount reduces signal loss from roof.
- Coax cable connects gateway to W4.

2.2. CORE Service App

- Reduces service and install times.
- Simple setup and test.
- Connects to the CORE Unit Controller via the wireless gateway.
- Pairs with a simple button press (requires physical access).
- Used for install, service, and maintenance of Model L.

2.3. Wireless Sensor

- Reduces install costs
- Simple averaging and setup
- Wireless connection to CORE Unit Controller Via wireless gateway
- Easy install
- Optional repeater boosts signal
- Easy to move with building construction
- Up to 5 sensor per RTU
- Up to 5 repeaters per RTU
- Sensors will automatically average
- Reliable BLE Mesh
- LCS-5030 (CAT# 21L07)
- TMP / RH / After hours override
- 24VAC or 4AA battery
- >2 year battery life
- Wireless or S-BUS (Both included)
- Locking hex screw

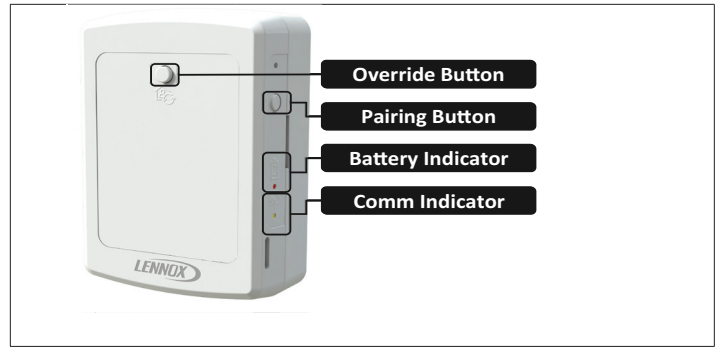

Figure 4. Wireless Sensor (21L07)

2.4. Wireless Repeater

- Used to “repeat” signal to sensors
- Increase effective range
- (CAT# 21L09)
- Up to 5 repeaters per RTU
- 24V ONLY
- Wireless ONLY
- Locking hex screw

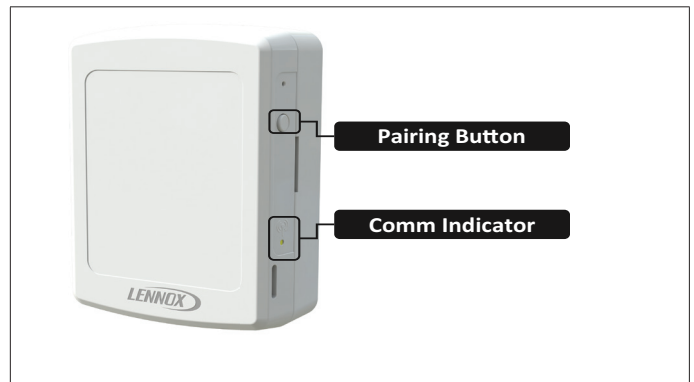

Figure 5. Wireless Repeater (21L09)

2.5. Cloud Firmware Updates

- Internet connection is required
- On-demand or automatic
- CORE Unit Controller connects to cloud via IP (Ethernet)
- Can check on demand or nightly
 - > Configurable via app
 - > Default: On demand
- Free updates
- Updates are also available via USB

3. Network Types

The following are the types of communication network types supported.

Table 3. Network Types

Screen Label	Network Type
LON	LonTalk
BACNET	BACnet MS/TP and IP
LCONN	L-Connection
RTU	Rooftop Unit stand-alone mode status indicator

4. Unit Operation

This section describes the display and control buttons, how to configure the unit, and how to read stored configuration data, status, and alarms.

The CORE Unit Controller is an input and output junction point. If in the thermostat mode, thermostat inputs at P297 result in an output to unit components. If the heartbeat LED is not flashing, see "Table 1. LED Operation Indicators" on page 5 for heartbeat operation. If the display shows an alarm. If the thermostat input indicating lights are not responding appropriately, check the thermostat or a DDC control acting as thermostat inputs into P297.

Basic cooling and heating functions may be energized to test major unit components by using the CORE Unit Controller testing function or by using jumper wires on the Field Wiring Termination plug P297.

5. CORE Service App Menu Selection Overview

Refer to "10. CORE Service App RTU Menu" on page 10 for details for Setup, Data, Service and Settings options.

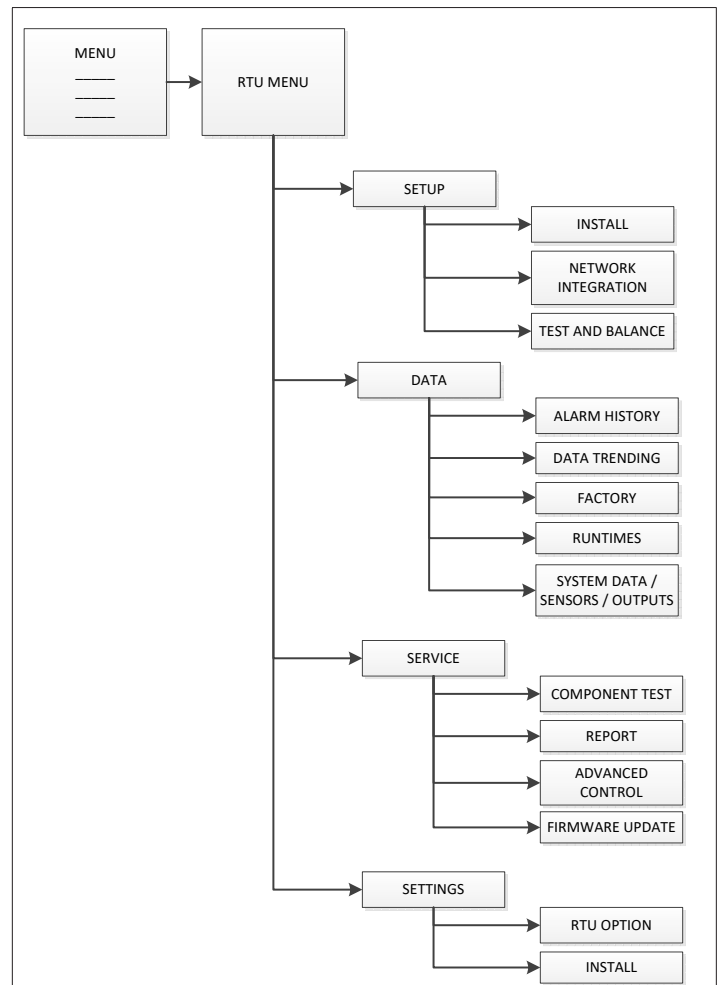

6. Pairing CORE Service App to CORE Unit Controller

- The mobile application is compatible with the CORE Unit Controller.
- The mobile application can discover the CORE Unit Controller if within 50 feet of the mobile device being used.
- The mobile application will list the units by signal strength.
- The unit friendly name is displayed.
- Select the desired unit from the discovery list. The four digit code desired on the unit will show the code listed in the discovery list.
- Once the unit has been selected, connection should be established to your device within 10 seconds.
- Information displayed once pairing is completed will be RTU name, model number, serial number and firmware version.

7. System Overview - Room Sensor Mode

- a. The system overview shall put emphasis on the zone temperature and RH.
 - The zone temperature / rh indicates a “__” if out of range.
 - The RH value will not appear if not configured.
 - b. The system overview in room sensor mode places emphasis on the current operating modes.
 - c. The system overview indicates all active operating modes with a priority on heating and cooling associated modes.
- NOTE:** *If dehumidification mode is active, this is displayed, and not cooling for example,*
- d. The system overview lists the following parameters at the top of the screen:

- Return Temperature
- Discharge Temperature
- Setpoints (Heating and Cooling)
- Network Status
- The system overview shall also indicate:
- Occupancy
- RH setpoint (if applicable)
- Outdoor Air Temperature
- Damper Position (if equipped)
- Active Alerts

- e. Additional Settings

- PreInstall
- Test
- Smoke
- Off on Alarm
- Delay up to 5 minutes
- Delay up to 20 seconds
- Start up

- Low Ambient Lockout
- Morning Warm-Up
- Pre-Cool
- Free Cooling
- Cooling
- Heating
- Dehumidification
- Fresh Air Cooling
- Fresh Air Heating
- Cool + Max Open Economizer
- Cool + Modulate Economizer
- Compressor Load Shedding
- Blower On - OAS
- Blower On
- No Demand - OAS

8. Active Alarms

- The mobile app will display other alarm information such as time of occurrence, and troubleshooting information.
- The mobile application will indicate all alarm information per the active alarm requirements.
- The mobile application will indicate the number of occurrences of a past alarm in the past thirty (30) days.
- For alarm details, go to “14. Alarms” on page 40.

9. CORE Service App General Menu + User Preference

- This screen allows the user to set the temperature units (°F or °C).
- Allows the user to set the screen mode, options are dark or light modes.

10. CORE Service App RTU Menu

The following options are available under this menu selection:

10.1. Setup

10.1.1. Install

This section includes the following:

- Date and time and the option to use the mobile device data and time setting.
- RTU Name
- Model Number (see “Figure 6. Model Number”) and serial number. Model, serial and catalog numbers are located on the RTU nameplate.
- RTU Information. Configuration ID 1 and 2 can be entered here. See figures “Figure 7. Configuration ID 1” on page 11 and “Figure 8. Configuration ID 2” on page 11 for further details.

This section addresses the requirement that specific configuration information must be completed using the SETUP / INSTALL feature if a new unit controller was being installed. Other requirements are the addition of accessories that were not factory-installed. Model number, configuration ID 1 and 2, catalog number, serial number and RTU description are all key items required to be completed for the system to operate correctly. Running the SETUP / INSTALL wizard allows the installer to verify that all fields have been completed as required.

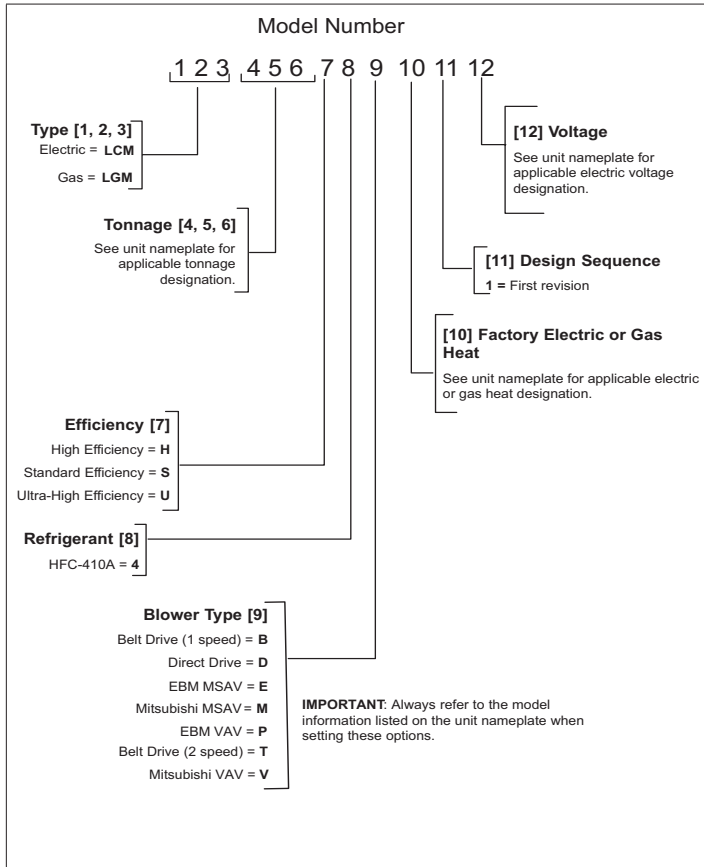

Figure 6. Model Number

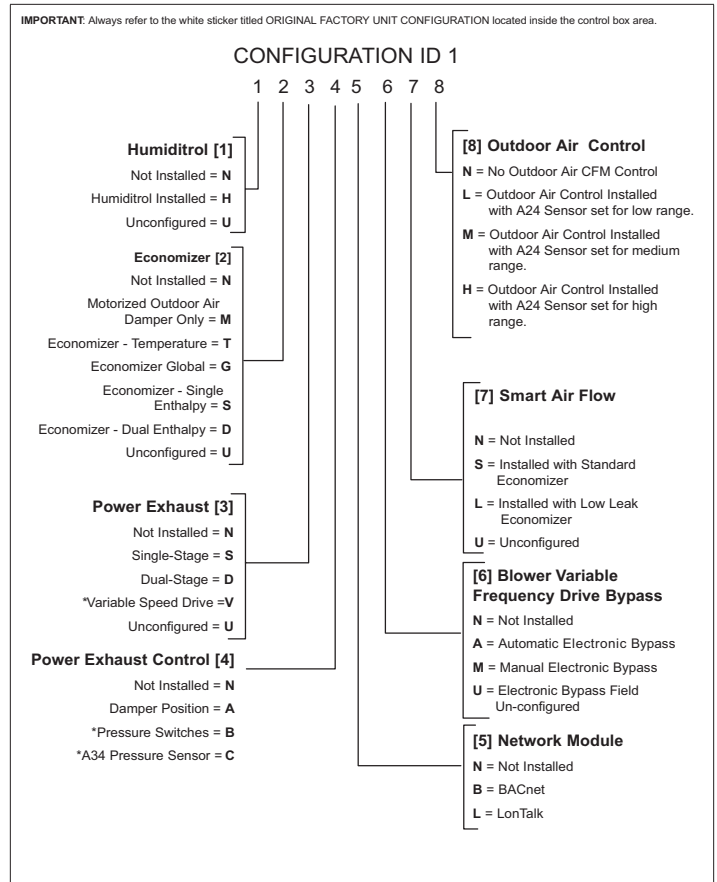

Figure 7. Configuration ID 1

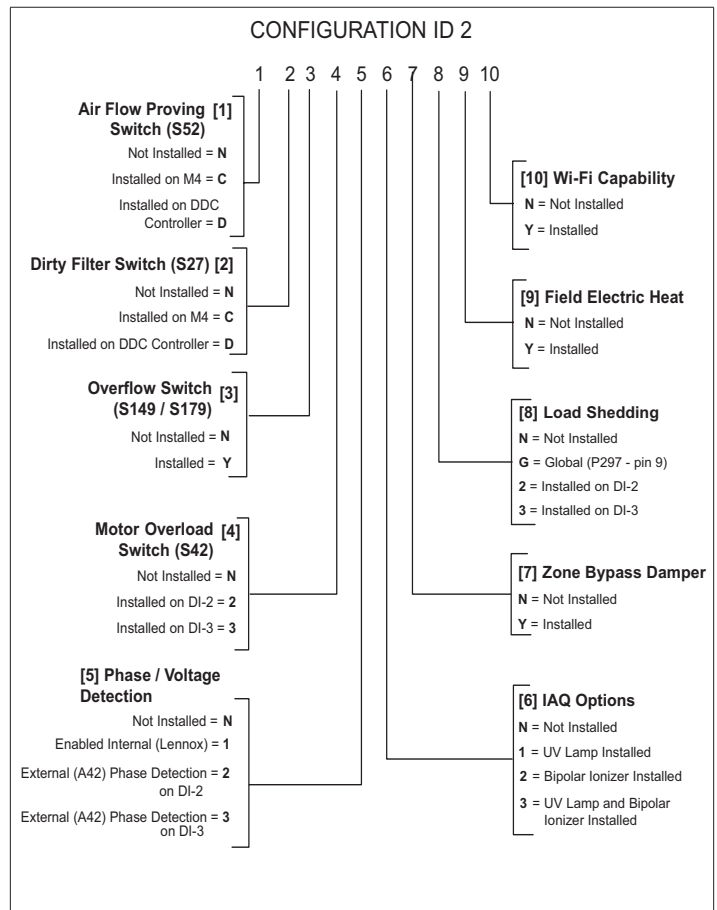

Figure 8. Configuration ID 2

10.1.2. Install Menu Navigation

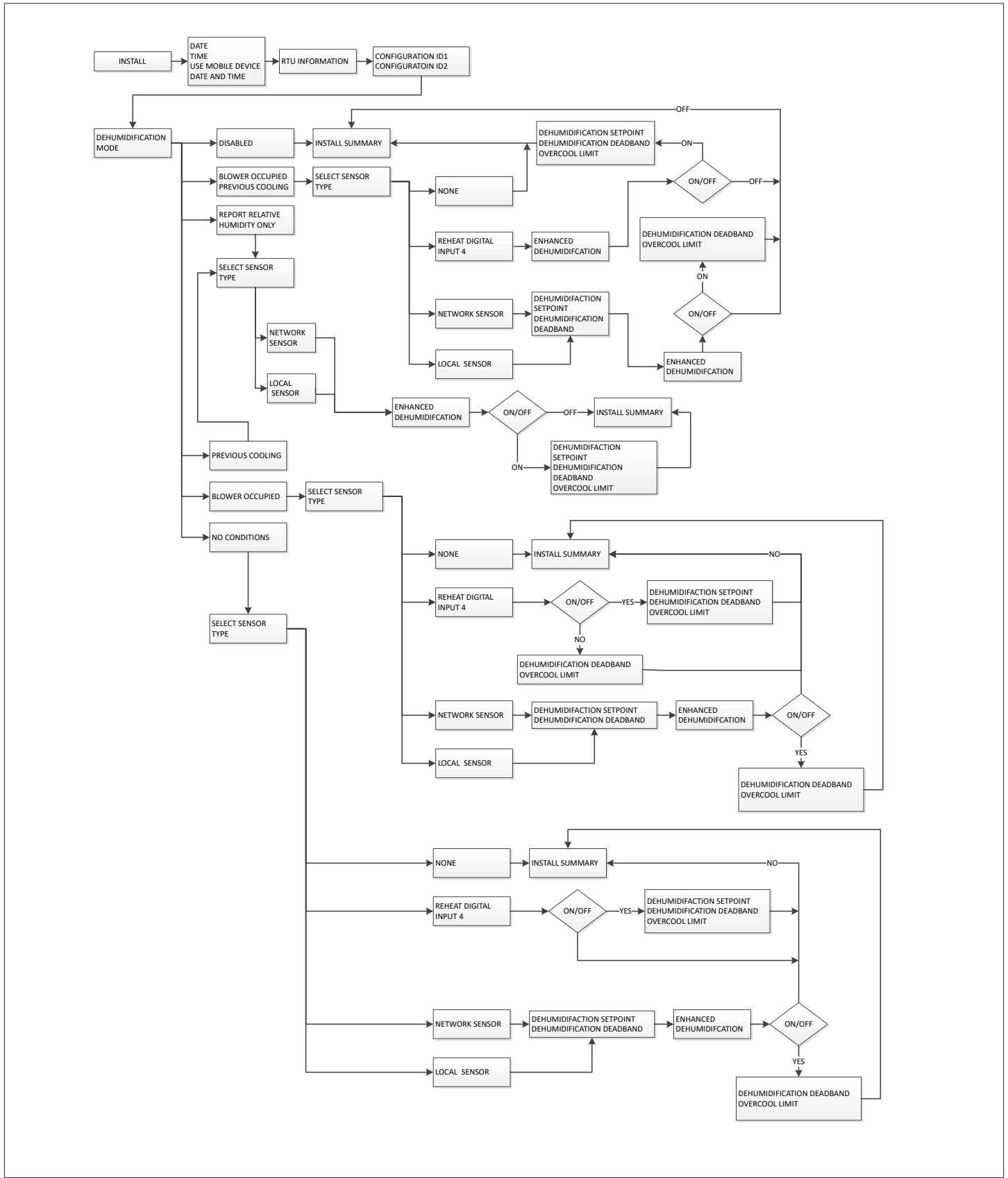

Figure 9. Install Menu Structure

10.1.3. Network Integration

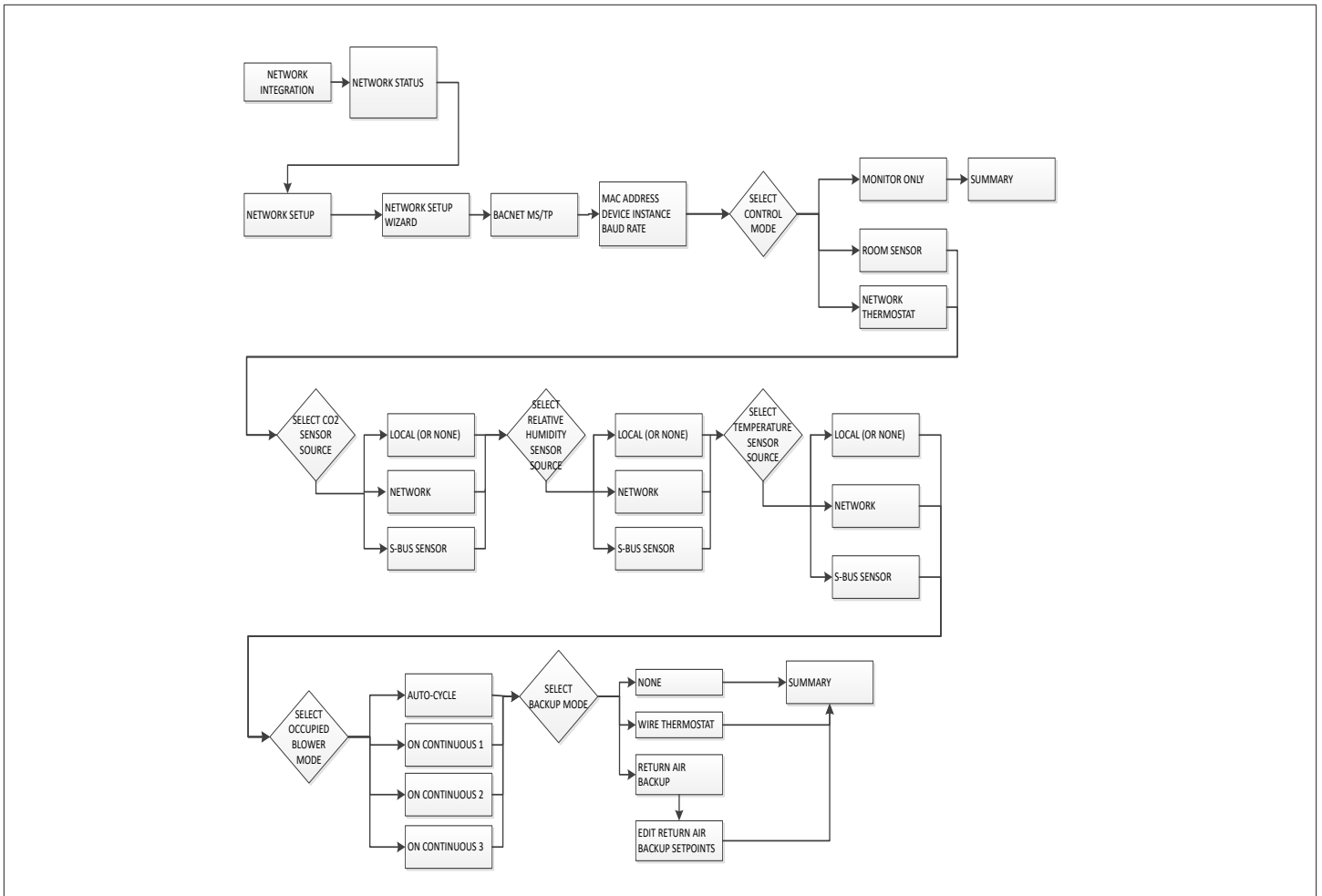

Figure 10. BACNet MS/TP Menu Structure

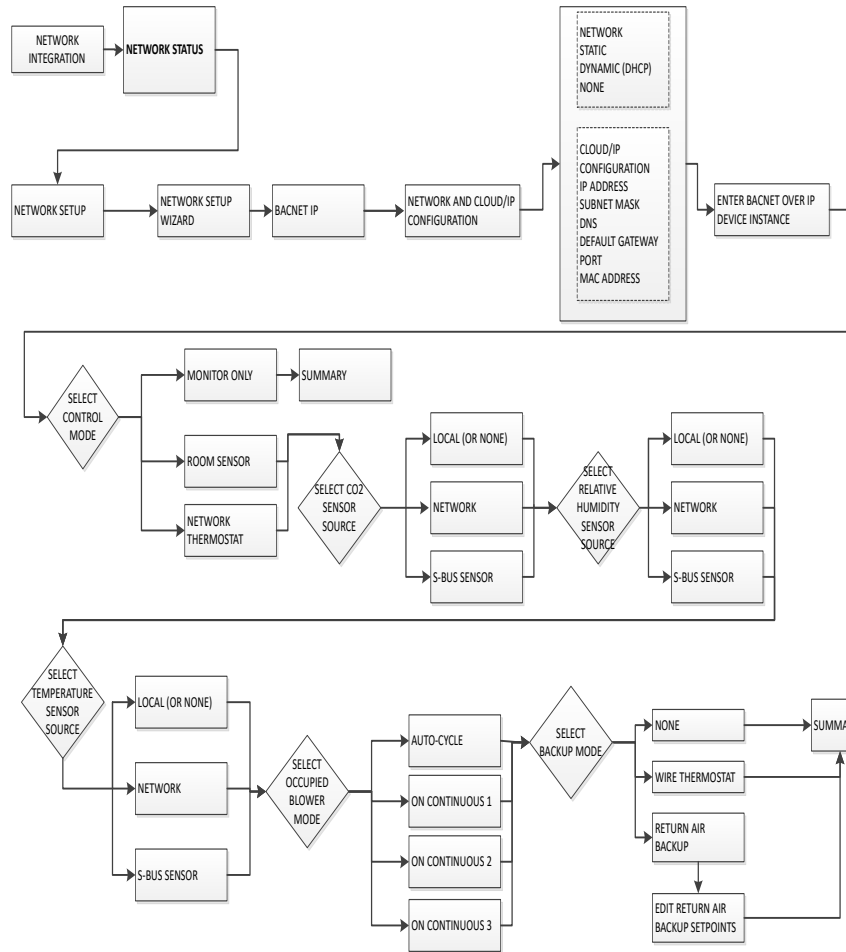

Figure 11. BACNet IP Menu Structure

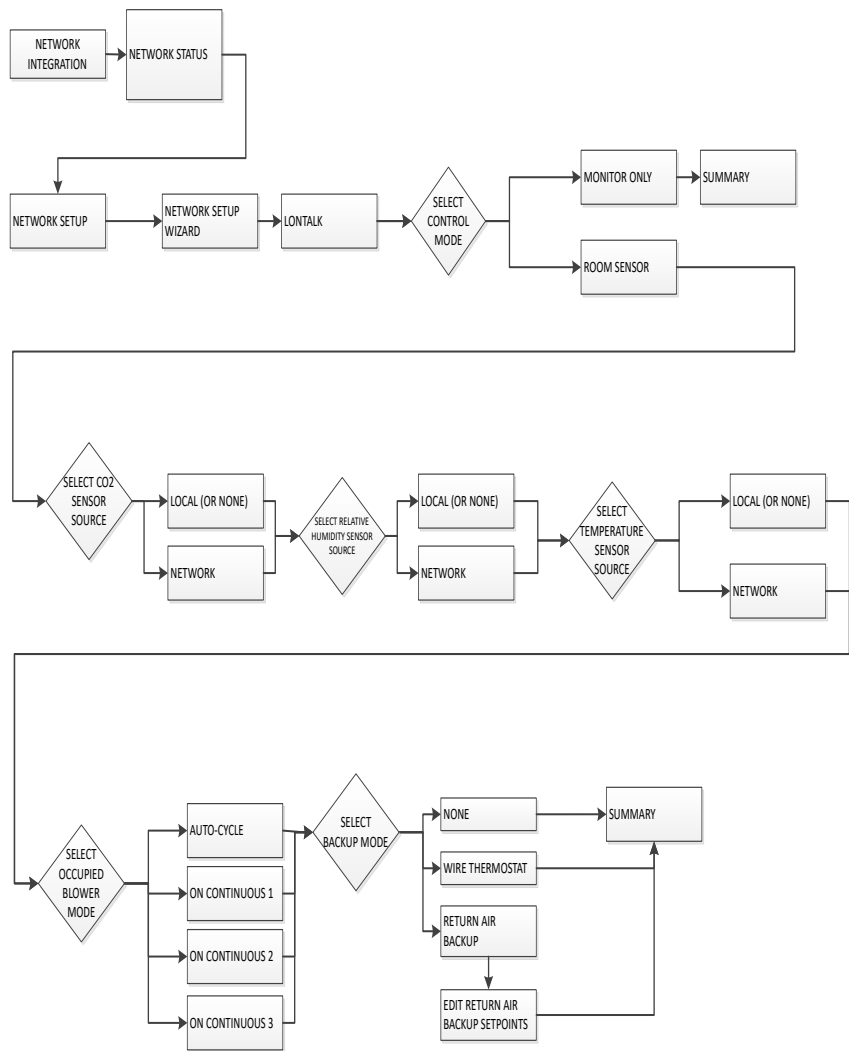

Figure 12. LonTalk Menu Structure

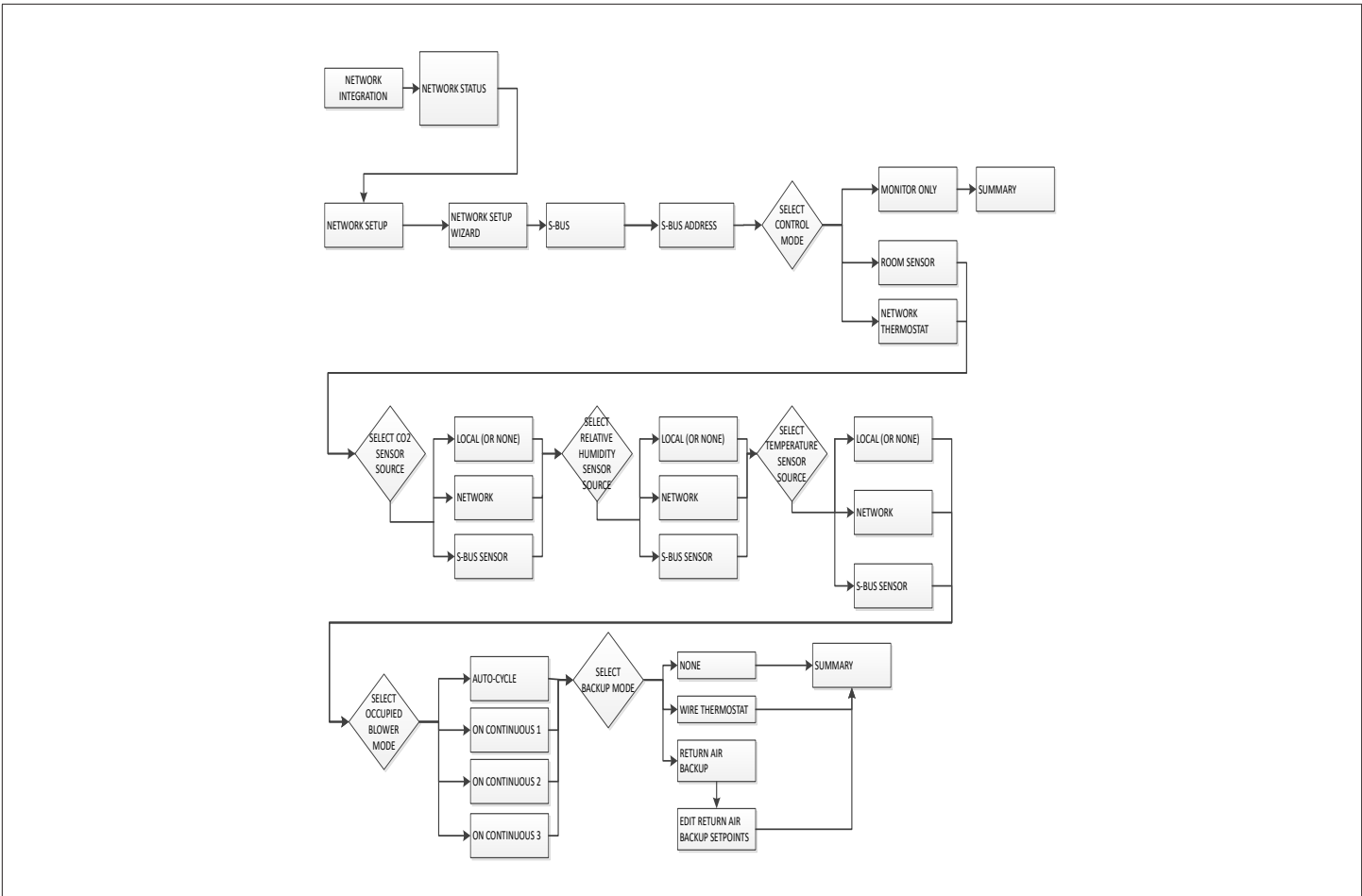

Figure 13. S-Bus Menu Structure

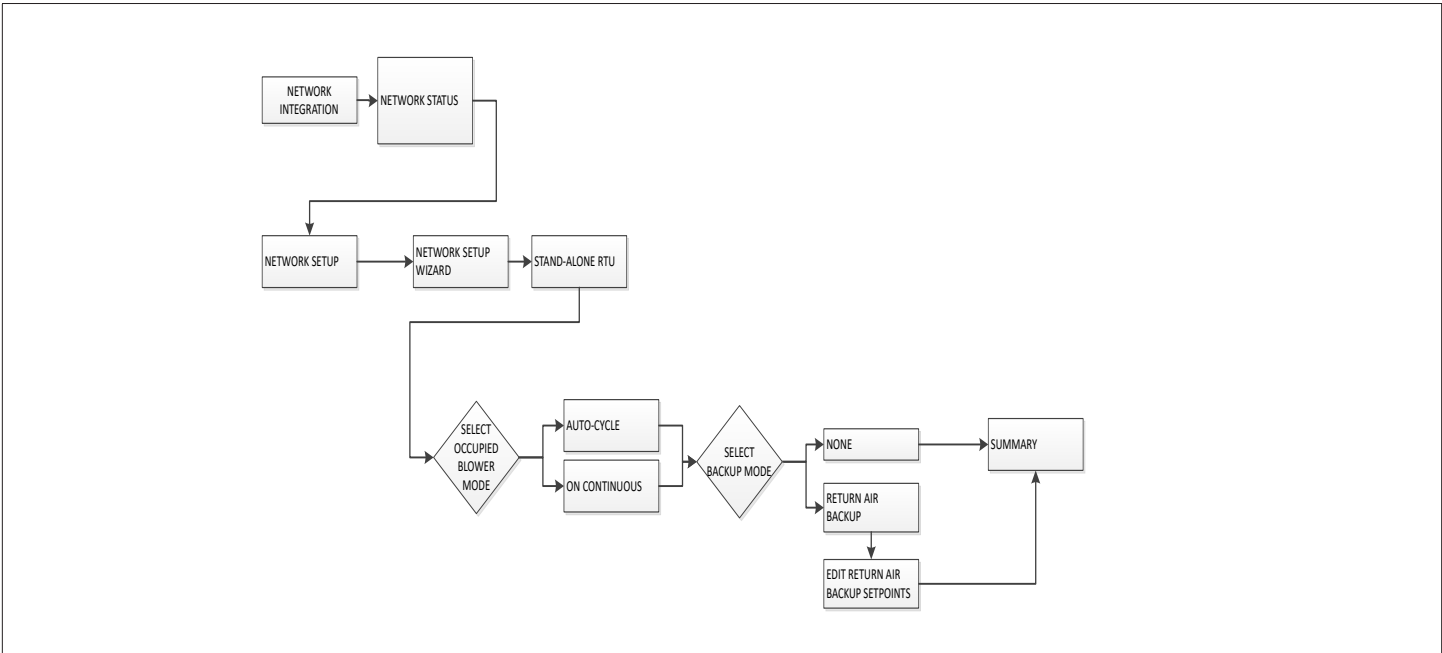

Figure 14. Stand-Alone RTU Menu Structure

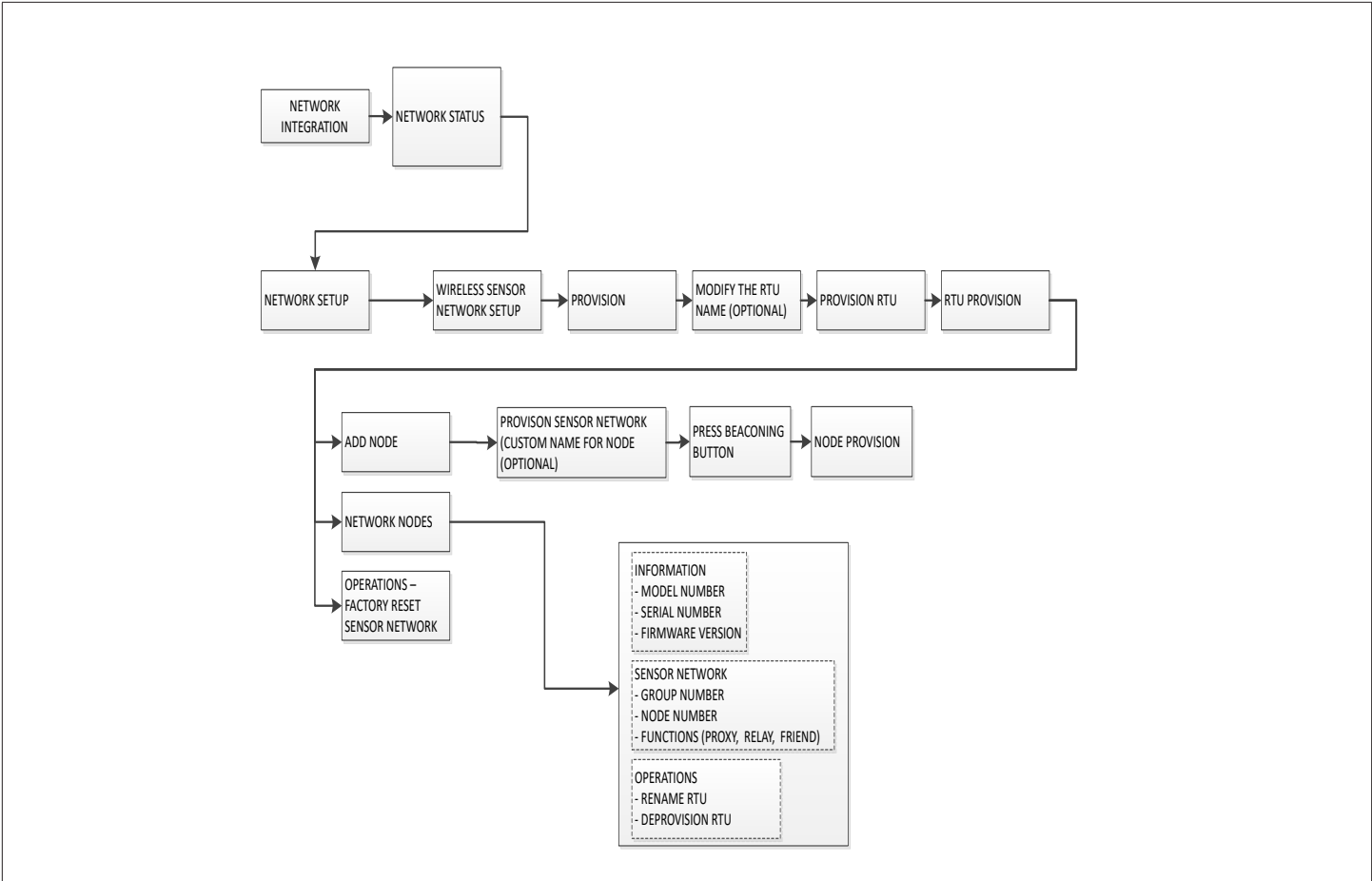

Figure 15. Wireless Sensor Network Setup Menu Structure

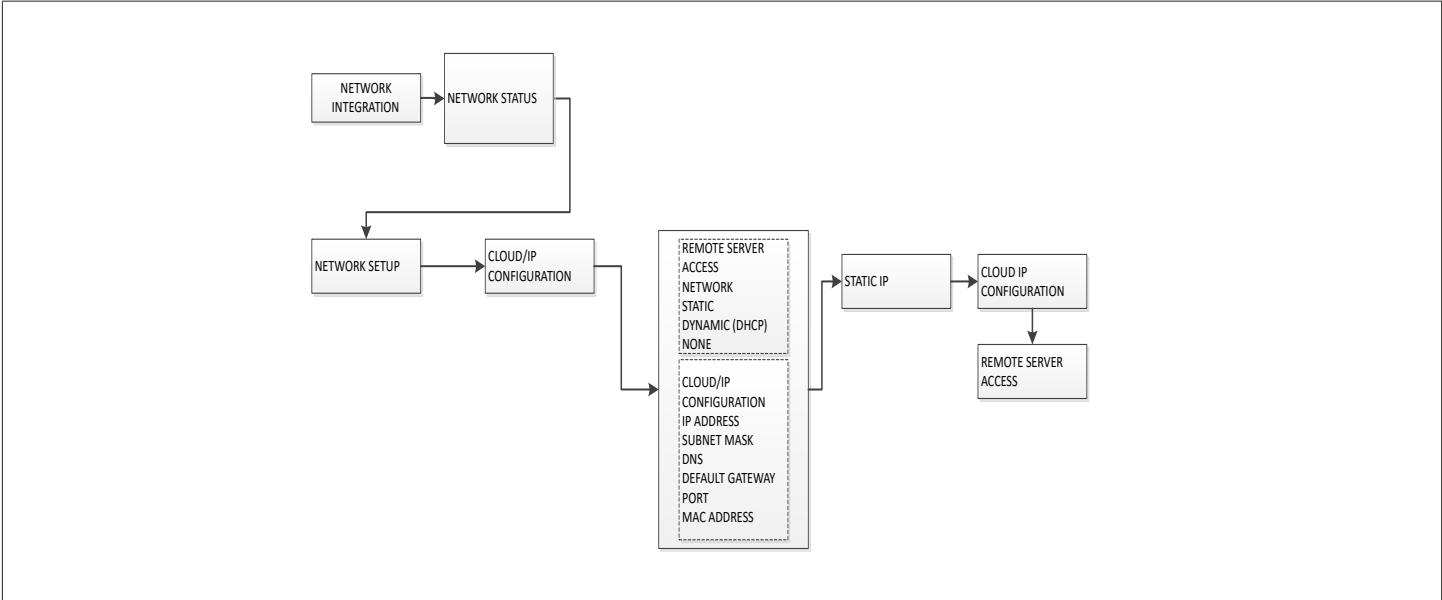

Figure 16. Cloud/IP Configuration Menu Structure

10.1.4. Test and Balance

- Blower: Includes Blower Calibration, MSAV Blower and VAV Calibration,
- Damper: Includes Economizer Options, Free Cooling, Damper Calibration (closed and open),

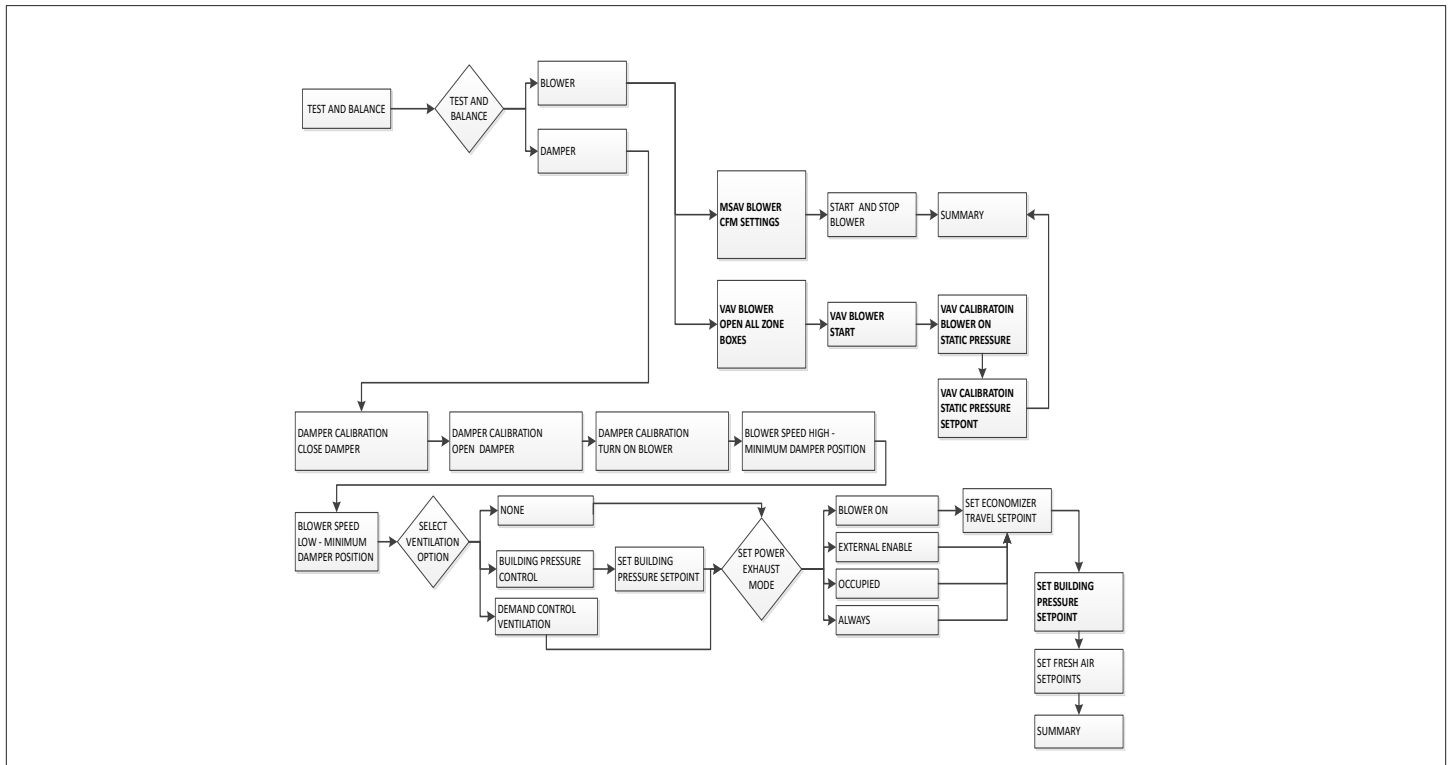

Figure 17. Motorized Outdoor Air Damper Only Menu Structure

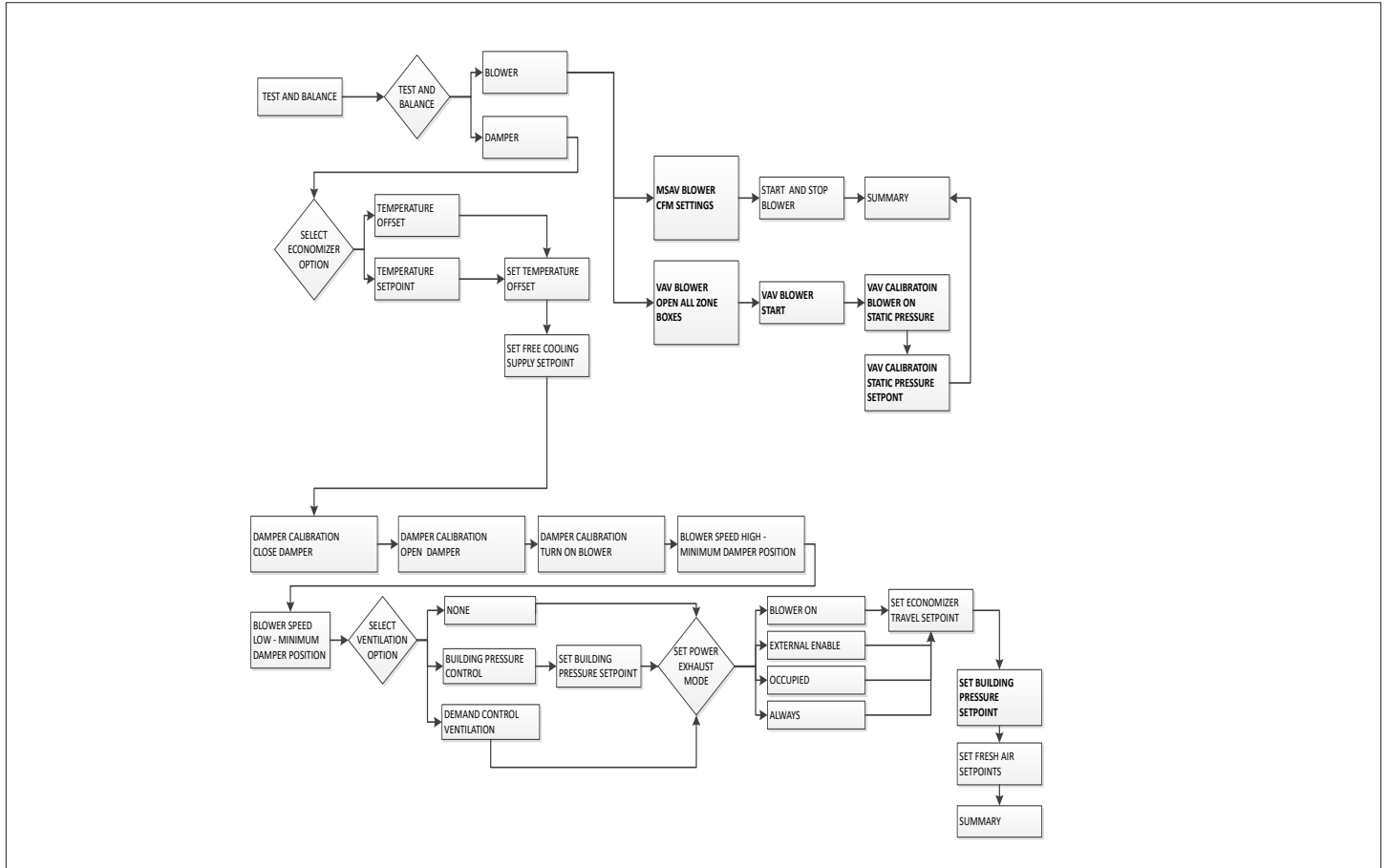

Figure 18. Economizer - Temperature Menu Structure

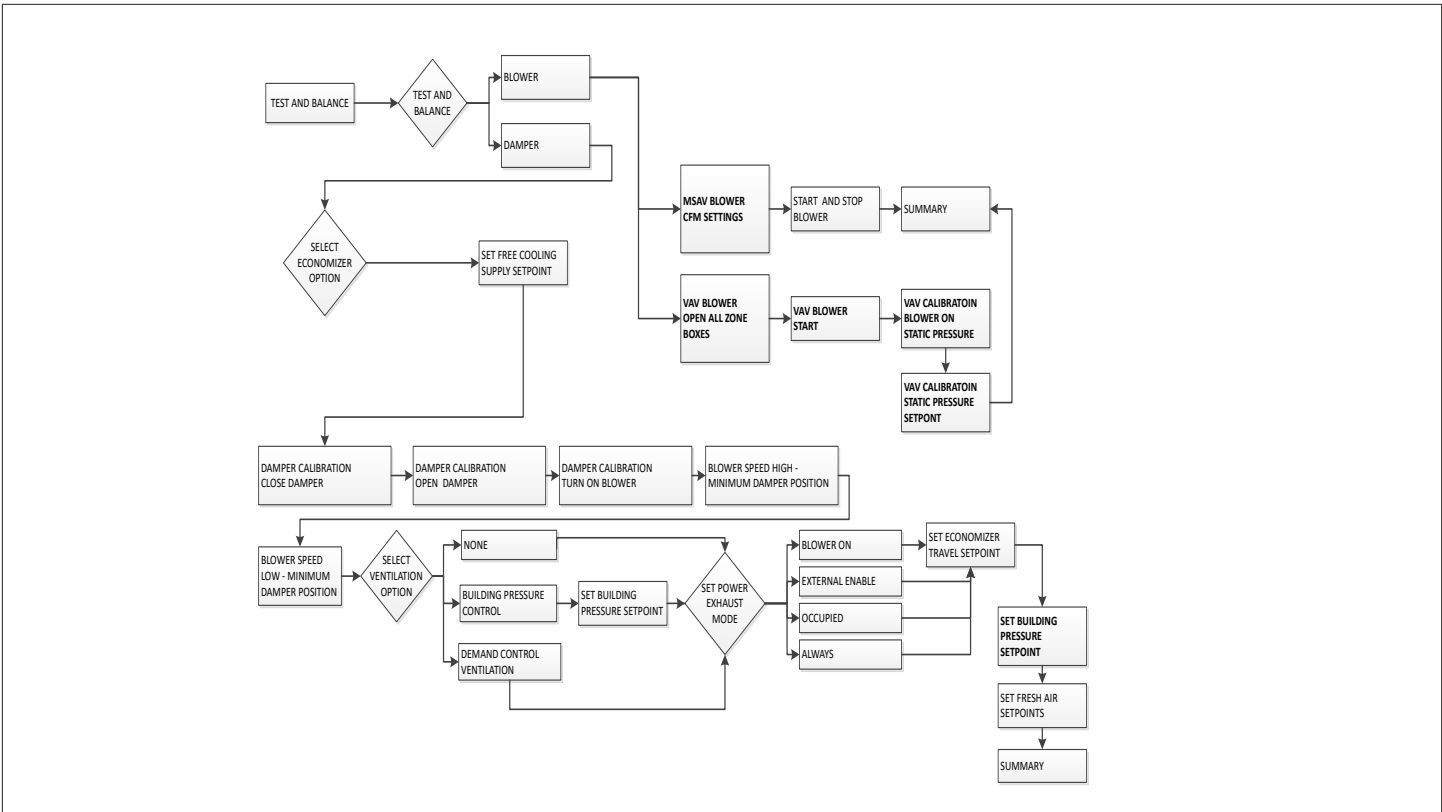

Figure 19. Economizer - Global Menu Structure

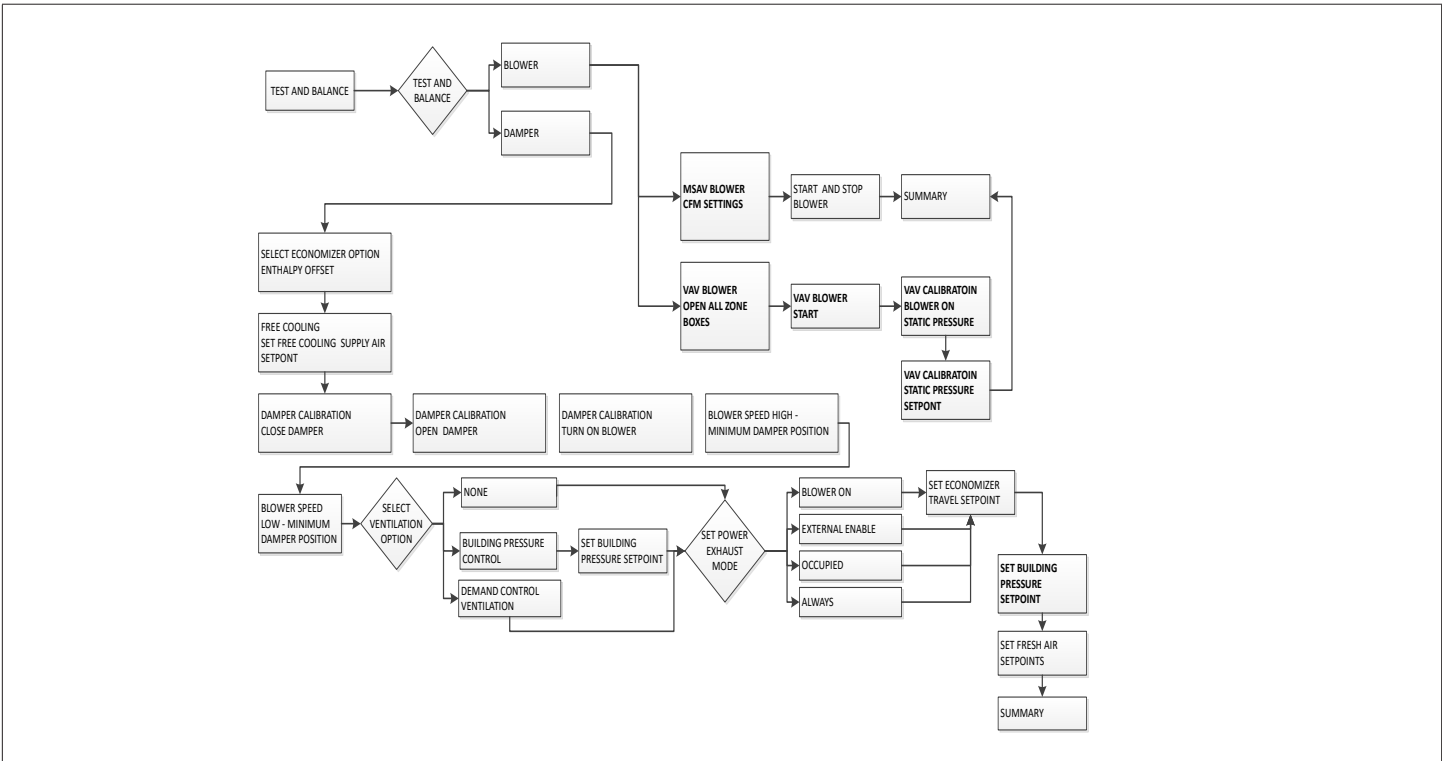

Figure 20. Economizer - Single or Dual Enthalpy Menu Structure

10.2. Data

10.2.1. Alarm History

The unitary controller will produce active and past alarm codes. As such, the mobile application will show all active alarm codes, and a limited history of formerly-active alarm codes, based upon the storage capacity of the unitary controller. The CORE Service application will:

- Display alarm information received from the unitary controller.
- Display action alerts. Alarms will be displayed in chronological order from most recent to last recent.
- Display other alarm information such as time of occurrence, and troubleshooting information.
- Indicate all alarm information per the active alarm requirements.
- Indicate the number of occurrences of an alarm in the past thirty (30) days.
- See “Table 11. CORE Control System Alarm and Event Codes” on page 40 for alarm details.

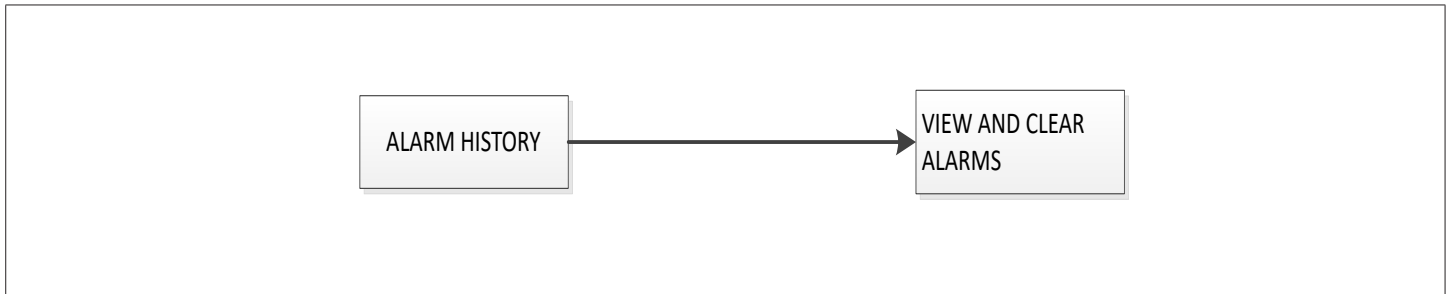

Figure 21. Alarm Menu Structure

10.2.2. Data Trending

'Trended data within the CORE controller is stored internally for up to two weeks and available in a user friendly format at X interval for help in troubleshooting previous operation with granular historical data.'

The main purpose of this feature is for troubleshooting a unit. Having granular, time-sensitive information is critical for this purpose. This is why having at least 5 minute intervals is set.

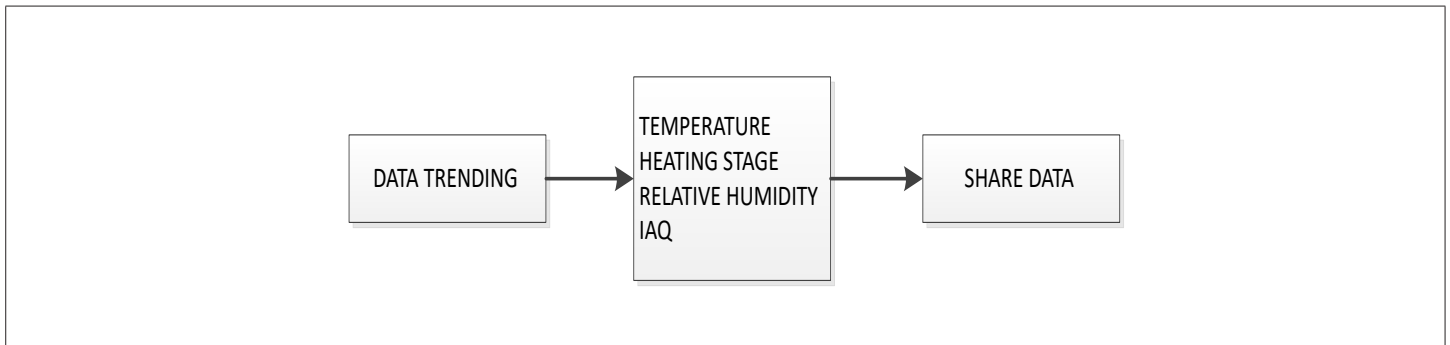

Figure 22. Data Trending Menu Structure

10.2.3. Factory

This section will display the software version, RTU description, catalog number, model number, serial number and configuration IDs 1 & 2.

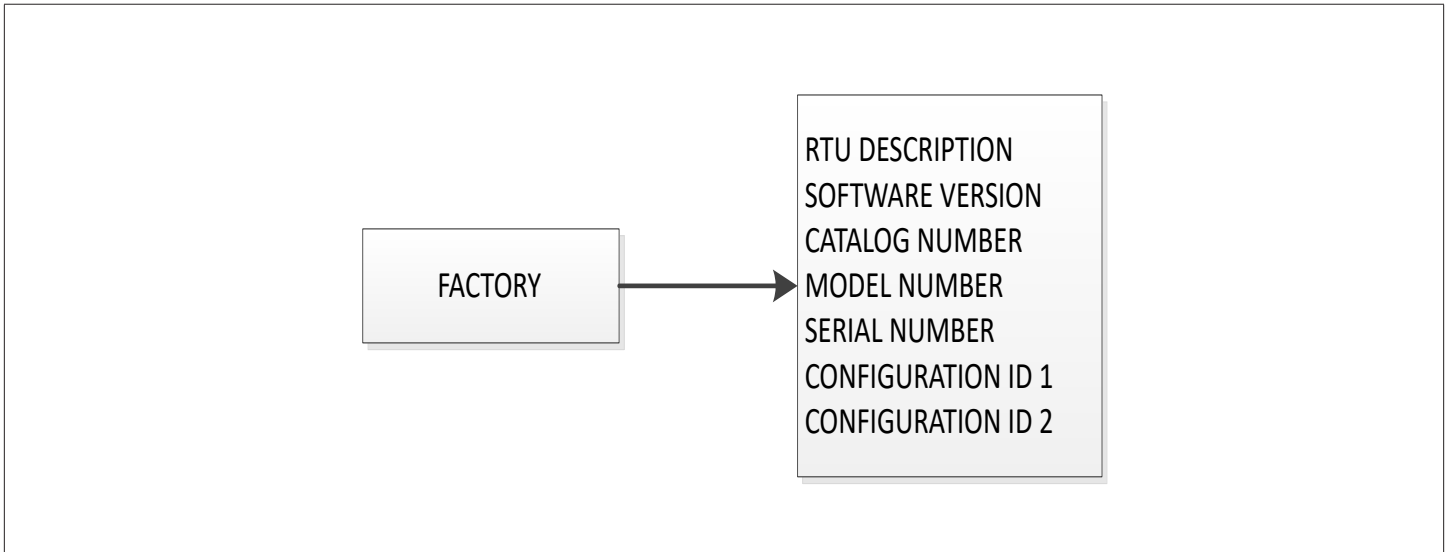

Figure 23. Factory Menu Structure

10.2.4. Runtimes

The mobile application allows the user to view the runtimes of the different system components.

- **Component Runtime** - The mobile application shall display hours of runtime for each component. The precision of the measurement shall be hours:minutes.
- **Runtime Cycles** - The mobile application shall display cycles of runtime by component.
- **Clearing of Runtime** - The mobile application shall support clearing of runtime on a component basis.

The available component runtimes are:

- Blower
- Compressor
- Condensing Fan
- Filter
- Heat State
- Power On
- Pre-Install
- Free Cooling Operation
- Power Exhaust Operation
- Dehumidification Operations

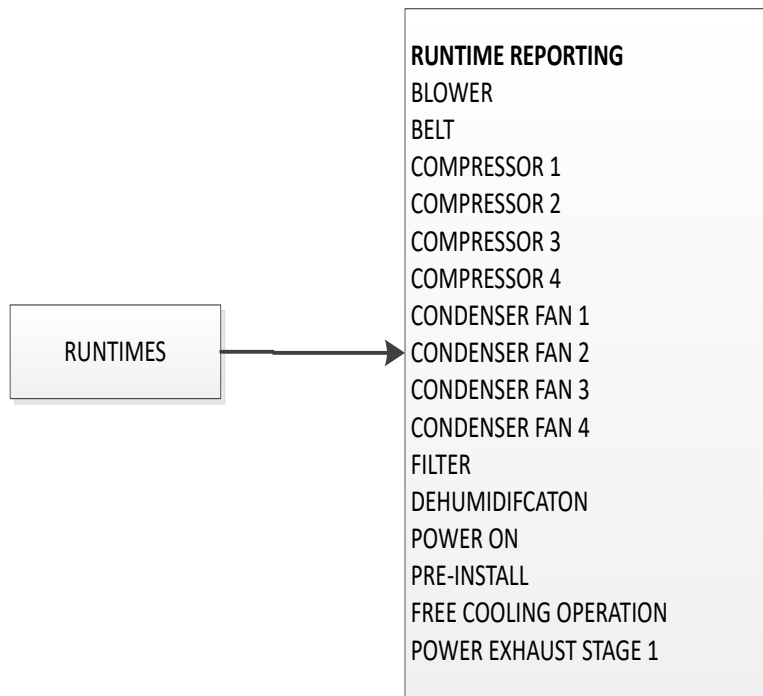

Figure 24. Runtimes Menu Structure

10.2.5. System Data / Sensor Data / Output

The follow inputs and outputs are as follows:

- Local Inputs. Examples are local thermostat inputs, sensors, digital inputs, setpoints and advanced.
- Network Inputs. Examples are BACnet MS/TP, BACnet IP, Lontalk and S-Bus
- Outputs. Examples are compressor, reheat coil, outdoor fans, heat status, damper, blower, power exhaust and other service relay output and Crankcase Heater 1 through 4.

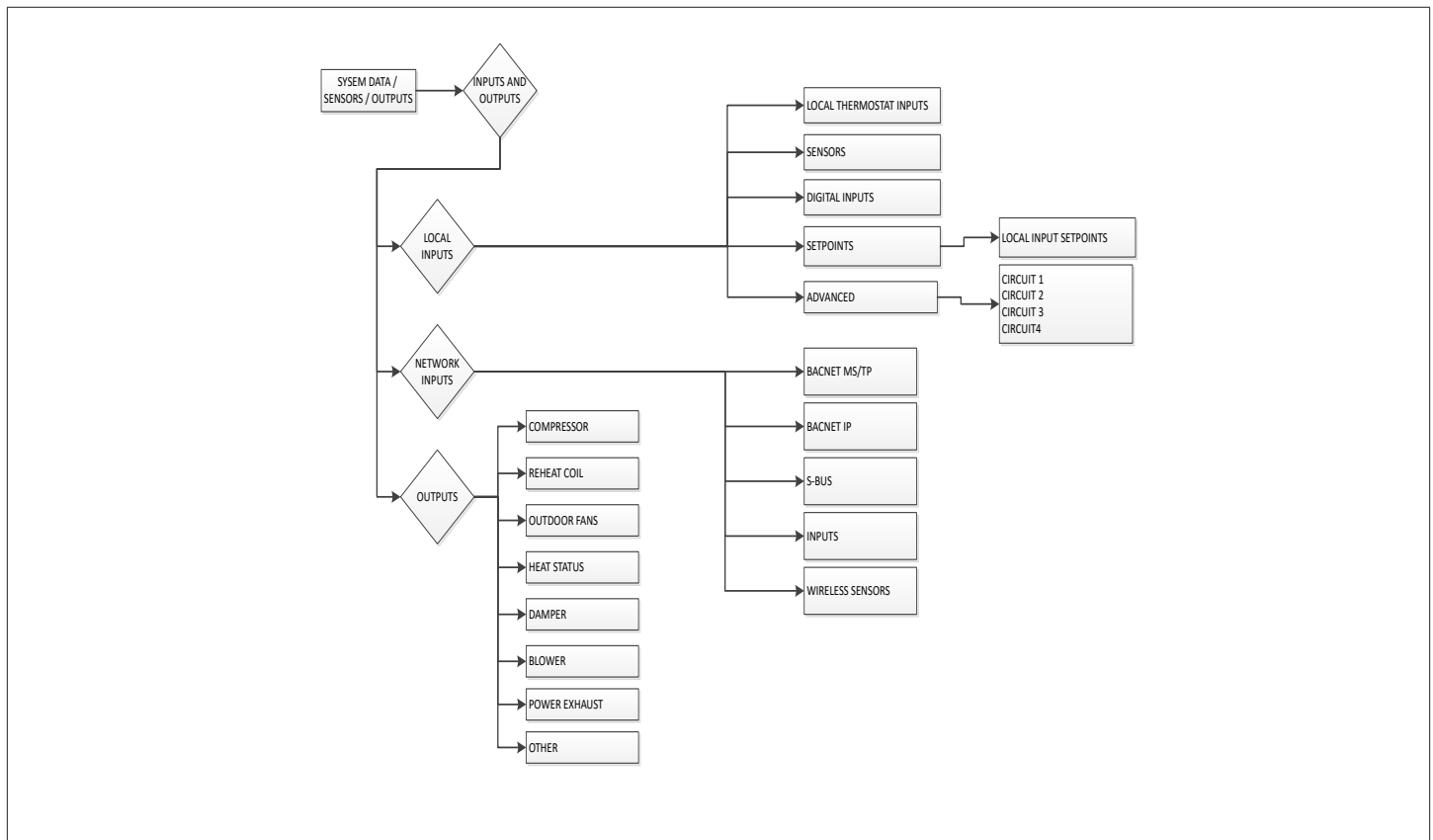

Figure 25. System Data / Sensors / Outputs Menu Structure

10.3. Service

10.3.1. Component Test

For cooling, the following tests can be run:

- Cooling Stages 1 through 4 - Tests are discharge and return air temperatures, compressor status and percent demand.
- Same tests listed above is available for all compressors present.

For heating, the following tests can be run:

- Heat Stages 1 through 4 - Tests are discharge and return air temperatures, and percent demand.

Other tests:

- Blower Speed
- Damper Position
- Power Exhaust
- Outdoor Fans 1 through 4

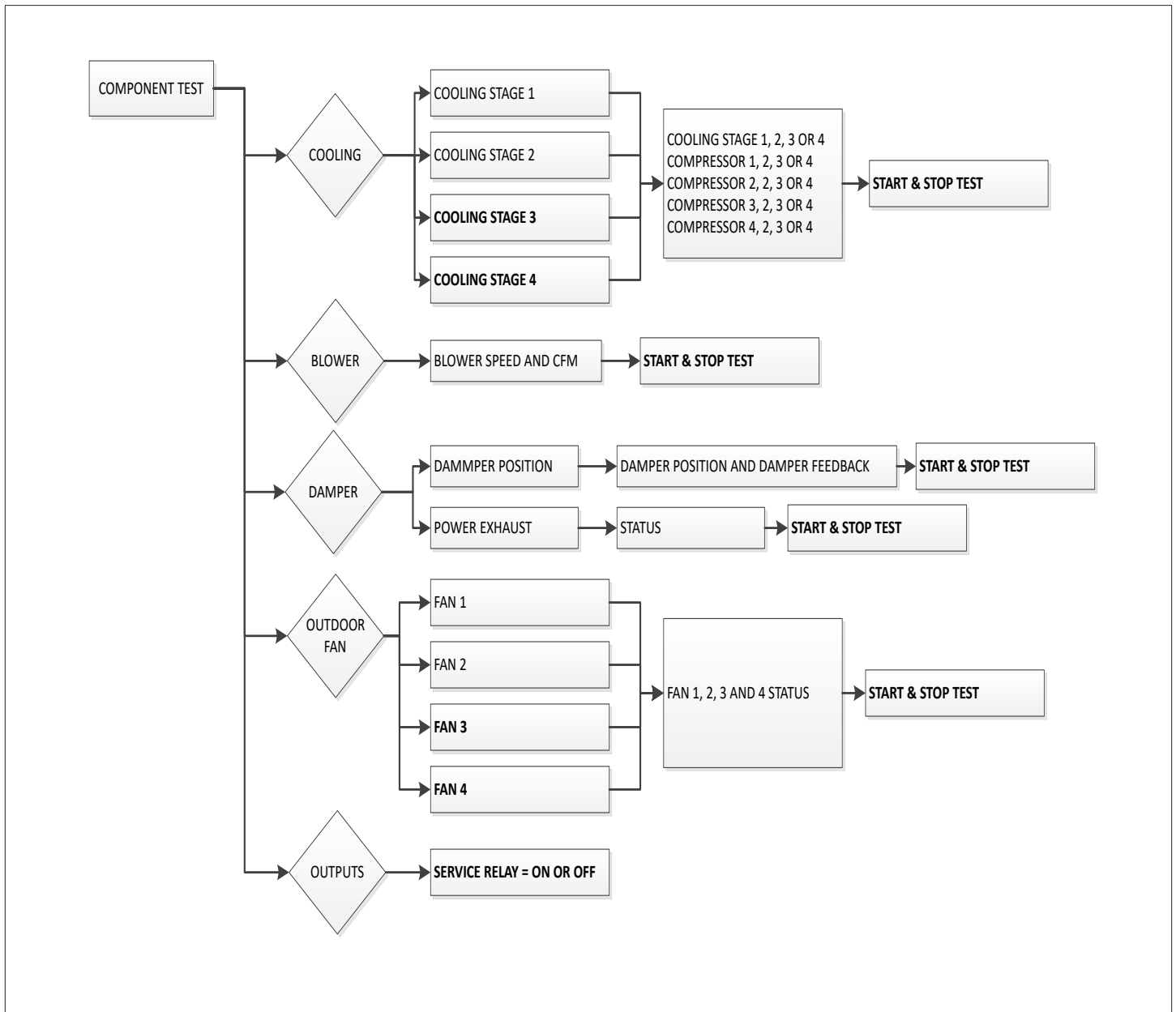

Figure 26. Component Test Menu Structure

10.3.2. Report

This section provides service reports, system logs, system profile and user profile. All logs and reports and either be downloaded to the via the W4

- Service reports - These reports are saved to the root directory of the USB storage device. In addition you can save the report to the mobile device being used and either text or email.
- System Logs - These logs are saved to the root directory of the USB storage device. In addition you can save the report to the mobile device being used or either e-mailed or use the device's share feature. There is also an option for data analytic uploads as well.
- System and User Profile - The profile is saved to the root directory of the USB storage device. In addition you can save the report to the mobile device being used or e-mailed. There is also the option in this section to load a system profile from USB as well.

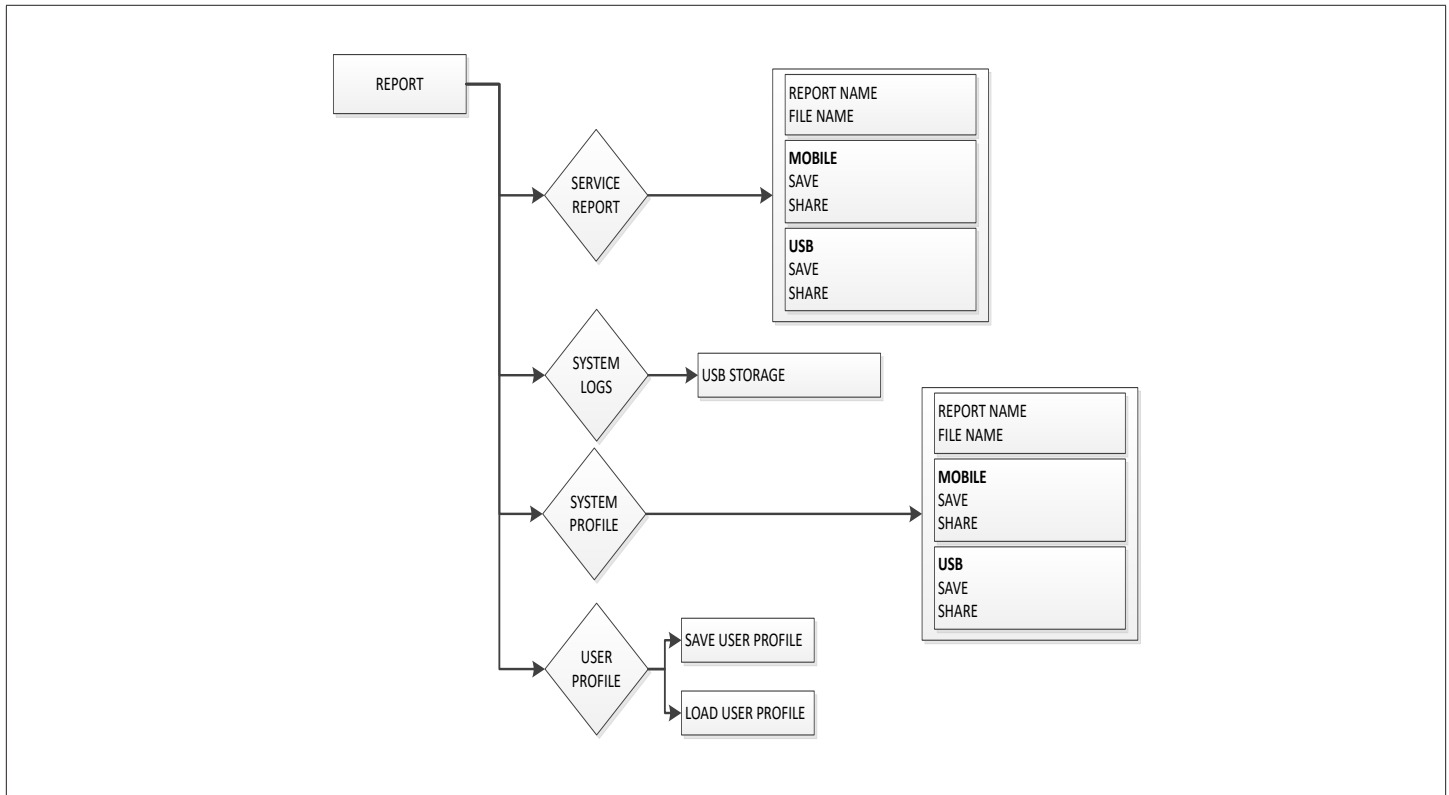

Figure 27. Report Menu Structure

10.3.3. Advanced Control

The interface will allow for the ability to remote reset the controller.

- The interface shall present a confirmation dialog to the user before proceeding with the reset command
- The interface shall indicate to the user that re-pairing will be necessary following the reboot (assuming this is necessary)

The component test functionality includes a support a "ClearDelays" functionality.

The clear delays functionality will clear timers in the CORE Control System.

The interface supports a "clear lockouts".

Features are:

- Remote Reset
- Clear Delays
- Controller Lockout - Locked or unlocked.

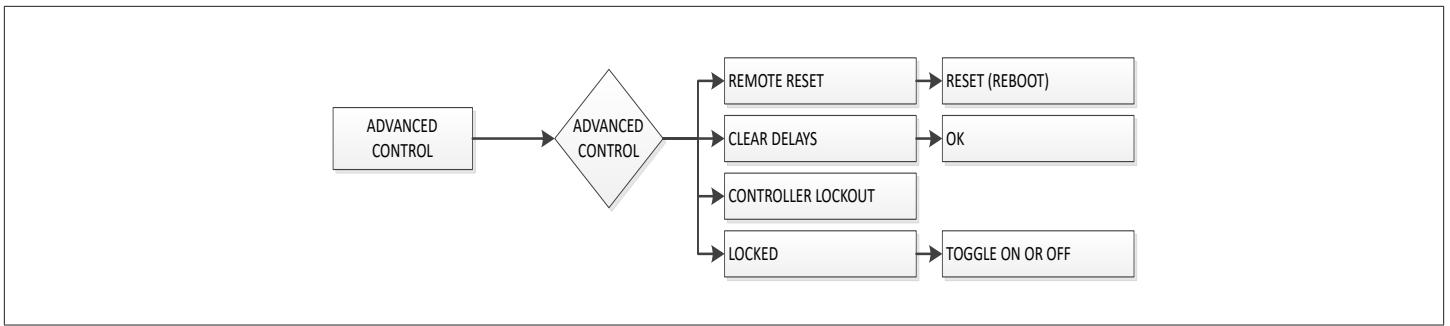

Figure 28. Advanced Control Menu Structure

10.3.4. Firmware Update

- The mobile application will update the firmware of the unitary controller.
- The mobile application will push any supported firmware image version to the unitary controller.
- Options are Automatic Cloud Update or upgrade from USB.

10.3.4.1 Updating Firmware

The mobile application shall pull the latest device supported firmware version from the cloud. The screen will list current firmware version, cloud firmware update set to on or off and upgrade from USB.

- Search for Updates:** The user has the ability to “search for updates” for new RTU firmware. If no updates are found, it will indicate so.
- File List Available for Download:** The user will be informed of the files found after query, and be allowed to start the firmware download.
- Downloading Image Status:** The user will be informed that the app is downloading the firmware from the cloud.
- W4 USB Drive as Source of Controller Firmware Image:** The mobile application will load a unitary controller firmware image from a W4 USB drive.
- Version Selectable:** The mobile application will allow the user to choose which version of the firmware in the USB drive shall be used.
- Confirmation Dialog:** The mobile application will present a confirmation dialog to the user before updating the CORE Unit Controller.
- Upgrade Time:** The mobile application should be able to upgrade the unitary controller firmware is approximately 60 minutes using USB. Cloud updates could be longer than 60 minutes.
- Upgrade with HVAC Service:** The mobile application will upgrade the unitary controller firmware without loss of HVAC service (excluding system reboot following upgrade).
- Installing Firmware Upgrade Status:** The mobile application shall update the firmware upgrade status every 5% of progress.

10.3.4.2 Automatic Update

- The user has the option to set automatic cloud updates to “On” for the RTU.
- Firmware Install Completion Status:** The user will be informed of the firmware update completion status from the RTU.
- Options:**
 - Upgrade completed successfully
 - FW hash value wrong
 - Programming of flash on equipment failed
 - Power cycle or other reset occurred during upgrade
 - M4 comm failure during upgrade
 - M4 comm failure on restart following upgrade
 - M4 FW version did not change following upgrade
 - M4 FW update aborted due to connection of technician device to bus

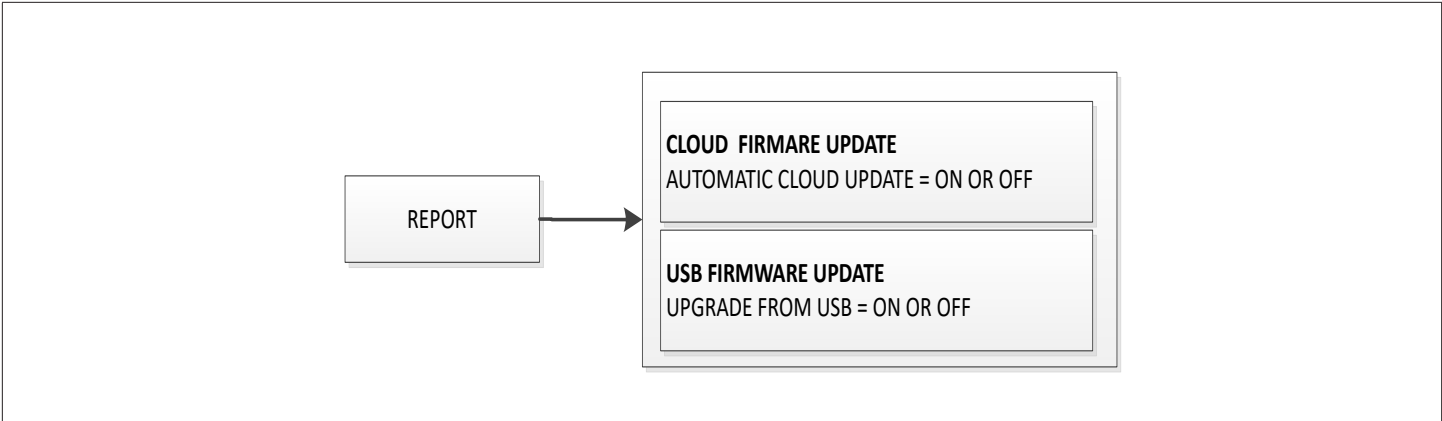

Figure 29. Firmware Update Menu Structure

10.4. Settings

10.4.1. RTU Options

Settings available are:

- Blower - Speed and VFD Bypass options
- Damper - Economizer Temperature and Economizer type with settings for Temperature offset and setpoint
- Dehumidifier
- Power Exhaust
- Edit Parameters - Categories are cooling, heating, air flow, VAV, economizer, control options and miscellaneous.

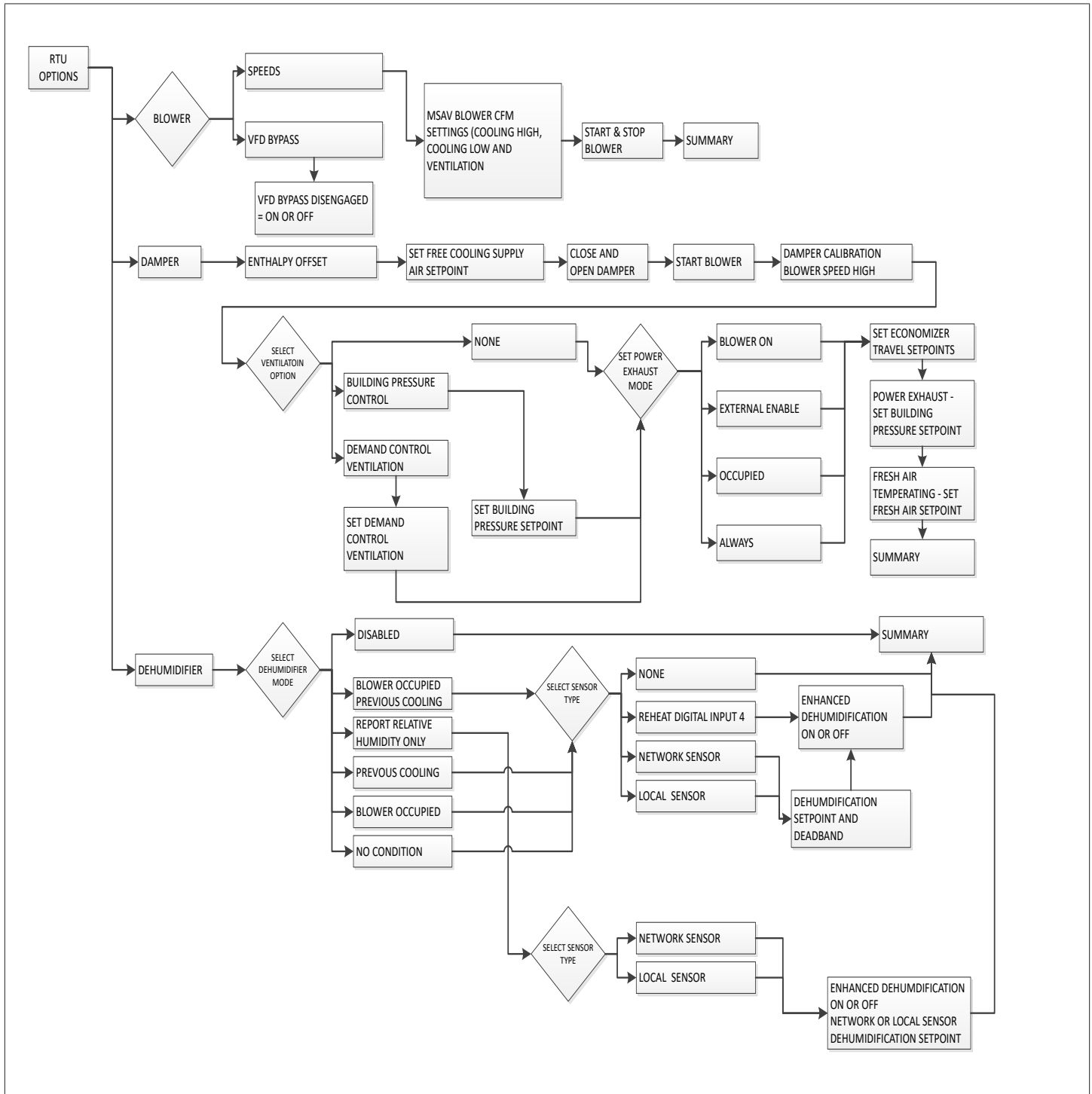

Figure 30. RTU Options - Blower, Damper and Dehumidifier

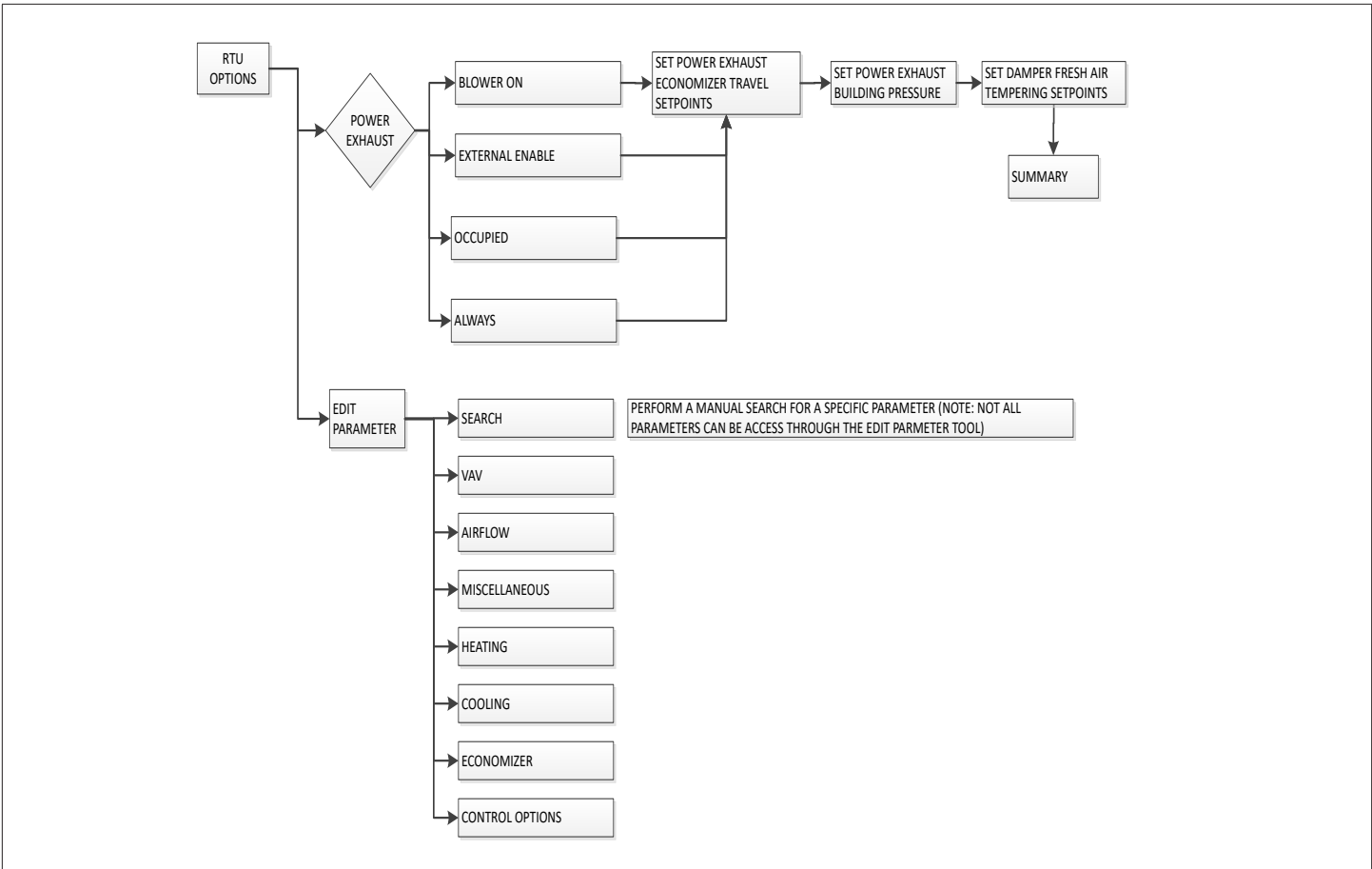

Figure 31. Settings - Power Exhaust and Edit Parameter

10.4.2. Install

The mobile application provides a menu to run “New Unit Setup”.

- New Unit setup if chosen shall direct the user towards the install menu.
- The mobile application shall provide a menu to run “Install New M4” (CORE Unit Controller).
- Install new CORE Unit Controller will first confirm with the user if it is okay to “Clear all Configuration”.
- If the user confirms that it is okay to “Clear All Configuration”, the app shall ask the user if they are sure.
- If the user confirms, the menu directs the user towards the Setup >RTU Menu > INSTALL.
- If the user cancels at any point, they shall be taken back to the Setup >RTU Menu > INSTALL.

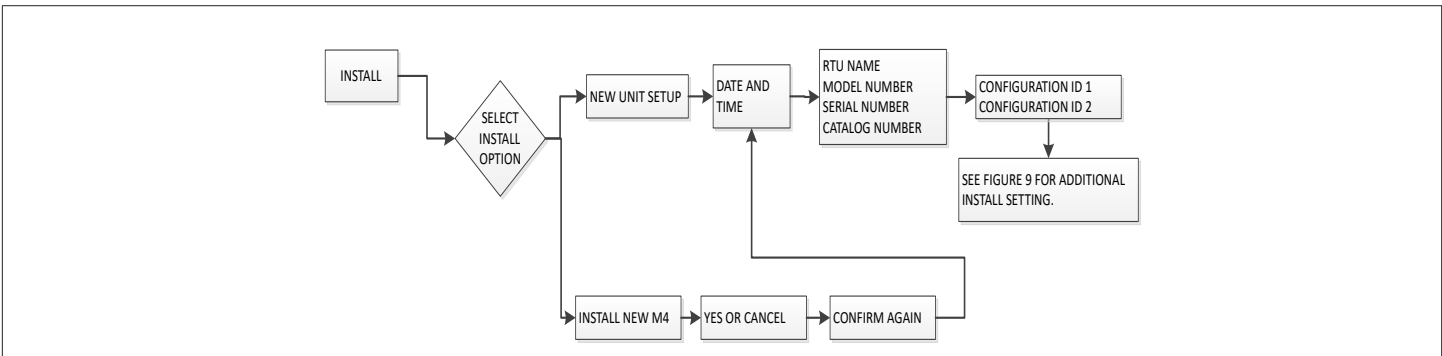

Figure 32. Settings - Install

11. Special Equipment Configurations

11.1. Thermal Protection Switches (S5, S8, S31 and S180)

NOTE: *Not all models use all of the reference switches. Verify with unit wiring diagram to confirm switch(es) used. Also refer the unit installation instruction for switches used and operation.*

Thermal protection switches open on a temperature rise to de-energize the corresponding compressor. Switches automatically reset when temperature drops.

The corresponding compressor is locked out after three occurrences (default) of either high pressure or high temperature conditions during a demand cycle. The number of occurrences can be changed using for Parameter 98. Adjustable range is 1 to 7 occurrences.

On certain compressors, these switches are in series with the high pressure switches, and will cause a 300 second delay (default) which is set using Parameter 110. This will also set off an alarm. Adjustable delay range is 64 to 1800 seconds.

Go to SETTINGS > RTU OPTION > COOLING > 98 (MAX HP OCCURRENCES)

Go to SETTINGS > RTU OPTION > COOLING > 110 (ERR TIME OFF DELAY)

NOTE: *Thermal protection switch alarms will not indicate an OFF ON ALARM state.*

3 to 6-ton sizes has a thermal protection switch connected to S5. When the compressor is de-energized due to an open thermal switch, alarm 192 is issued. When the compressor is locked out after three occurrences, alarm 193 is issued.

11.2. Blower Operation with Effective Occupancy

This section describes how network occupancy signals are combined to produce effective occupancy.

The blower runs to service heat and cool demands, regardless of the space occupancy. However when there is no heating or cooling demand there are options for how the blower should operate in conjunction with occupancy signals to keep the space ventilated, or the air stirred.

a. California Energy Commission Title 24 - The legacy option settings for OCC Blower Mode are AUTO CYCLES or ON-CONTINUOUS 1. These settings govern whether the blower runs continuously when the space is considered occupied, or cycles on/off with the heating and cooling demand.

To comply with the California Energy Commission Title 24 standard there are two additional values for OCC Blower Mode which are ON-CONTINUOUS 2 and ON-CONTINUOUS 3. See “Table 4. Blower Operation Description” for their descriptions.

b. LonTalk, BACnet and L Connection: These two new options are available when using these networks types that supplies a room occupancy signal (in addition to the scheduled occupancy).

NOTE: *For L Connection the same two options are also available when using an optional room occupancy sensor. If a room occupancy sensor is not physically installed and configured for the network, then the only options available for OCC Blower Mode are AUTO CYCLES or ON-CONTINUOUS 1.*

c. RTU Standalone: Since a room occupancy sensor cannot be used in this configuration, then the only options for OCC Blower Mode are AUTO CYCLES or ON-CONTINUOUS 1.

d. Enabling Network Type

To enable the network module, go to **SETUP > INSTALL** and run the setup wizard. When Configuration ID 1 appears on the screen, configure position 5 to one of the applicable network types. N = Not Installed, B = BACnet and L = LonTalk.

e. Menu Setup Procedure Method for OCC Blower Mode

These blower control options are handled by the OCC Blower Mode. These setting and be changed using the following menu path:

Go to **SETUP > NETWORK INTEGRATION > NETWORK SETUP WIZARD**. Depending on how Configuration ID 1, position 5 is set, different network types will be listed. Additional prompts concerning network configuration and sensor types will be asked) **CONTROL MODE = ROOM SENSOR > ROOM SENSOR OCC BLOWER MODE =**

Table 4. Blower Operation Description

OCC Blower Mode	Description
AUTO CYCLES	Blower cycles on/off with demand. (Legacy usage.)
ON-CONTINUOUS 1	Blower runs when either the occupancy sensor or schedule, or both, indicates occupied. (Legacy usage.)
ON-CONTINUOUS 2	Blower runs when both the occupancy sensor and schedule indicate occupied.
ON-CONTINUOUS 3	The same as option 2, but blower runs for 30 minutes and is off for 90 minutes when schedule is occupied but the occupancy sensor is not occupied.

Table 5. BACnet Occupancy Objects

Input	BACnet	Value
Manual	Occupancy Override Control AO 103	0: space occupied 1: space unoccupied 2: refresh space occupied override timer 3255: auto; clear timer and return to scheduler
Schedule	Occupancy Scheduler Control AO 104	0: space occupied 1-255: space unoccupied
Sensor	Occupancy Sensor Input AO 107	0: space occupied 1: space unoccupied 2-255: auto; return to occupancy scheduler state
Effective Occupancy	Effective Occupancy AI 241	0: space occupied 1: space unoccupied 2: space occupied (timed override)

Table 6. LonTalk Occupancy Objects

Input	BACnet	Value
Manual	nviOccManCmd Index = 11	0: space occupied 1: space unoccupied 2: refresh space occupied override timer 3255: auto; clear timer and return to scheduler
Schedule	nviOccSched1 Index = 10	0: space occupied 1-255: space unoccupied
Sensor	nviOccSensor Index = 12	0: space occupied 1: space unoccupied 2-255: auto; return to occupancy scheduler state
Effective Occupancy	nviEffectOccup Index = 26	0: space occupied 1: space unoccupied 2: space occupied (timed override)

Table 7. Blower Operation Schedule

Manual	Schedule	Sensor	Effective Blower Occupancy	OCC Blower Mode	Blower Operation
0, 2	n/a	n/a	OCCUPIED	AUTO-CYCLES ON-CONTINUOUS 1 ON-CONTINUOUS 2 ON-CONTINUOUS 3	Cycles On On On
1	n/a	n/a	UNOCCUPIED	AUTO-CYCLES ON-CONTINUOUS 1 ON-CONTINUOUS 2 ON-CONTINUOUS 3	Cycles
3-255	0	0, 2-255	OCCUPIED	AUTO-CYCLES ON-CONTINUOUS 1 ON-CONTINUOUS 2 ON-CONTINUOUS 3	Cycles On On On
3-255	0	1	OCCUPIED	AUTO-CYCLES ON-CONTINUOUS 1 ON-CONTINUOUS 2 ON-CONTINUOUS 3	Cycles On Cycles Cycles w/Stir
3-255	1-255	n/a	UNOCCUPIED	AUTO-CYCLES ON-CONTINUOUS 1 ON-CONTINUOUS 2 ON-CONTINUOUS 3	Cycles

11.3. Enabling Economizer and Settings

The economizer, when configured, controls:

- Damper position, which determines how much outdoor air is used to meet free cooling or indoor air quality requirements, and
- Optional power exhaust fans.

On a cooling demand, outdoor air is used for free cooling instead of first-stage compressor(s) when outdoor air is suitable.

To enable the economizer if installed:

Go to SETUP > INSTALL

When reaching Configuration ID 1, position 2 will need to be set to the applicable type of economizer. Valid types are:

- **M** = Motorized Outdoor Air Damper Only
- **T** = Economizer - Temperature (Note: Used for both set point and offset temperature control.)
- **G** = Economizer - Global
- **S** = Economizer - Single Enthalpy
- **D** = Economizer - Dual Enthalpy

11.3.1. Damper Feedback Calibration

Use the following procedure to perform a damper feedback calibration.

Go to SETUP > TEST & BALANCE > DAMPER > IS DAMPER CLOSED?

This drives the damper to the fully closed position. Visually inspect that the damper has stopped moving in the closed position, and answer **YES** to calibrate damper closed position feedback value.

Then the next screen will ask **IS DMPR FULL OPEN?**

This will drive the damper to fully open position. Visually inspect that the damper has stopped moving in the full open position, and answer **YES** to calibrate damper full open position feedback value.

11.3.2. Damper Operation During Free Cooling

These are operating profile options for the economizer damper (Parameter 164 - ECONOMIZER PROFILE) during free cooling when any compressor is on and can be selected as follows:

Damper opens to its max open position (Parameter 131 - FREE CL MAX DAMPER) when any compressors start.

NOTE: *When using Option 1 and after the compressor is stopped, the M3 shall resume damper modulation.*

11.4. Free Cooling Compressor Lockout Mode and Low Ambient Set Point

Go to SETTINGS > RTU OPTION > EDIT PARAMETER > COOLING = 285 (FRCL COMP LCKOUT MD).

Default value is 2. Range is 0 to 2.

- **0** = Disable Compressor Lockout
- **1** = Lockout Compressor if outdoor air is suitable regardless of outdoor air temperature.
- **2** = Lockout Compressor if outdoor air temperature is below Parameter 108 setting and Outdoor Air is Suitable (Default).

Go to SETTINGS > RTU OPTION > EDIT PARAMETER = 108 (FREE LO AMB LCKT SP).

Default value is 55.0°F. Range is 45.0 to 80.0°F.

11.4.1. Outdoor Air Suitable for Free Cooling

The CORE Unit Controller displays the outdoor air suitability information on the status screen.

The appropriate sensors are provided when the economizer is factory-configured. When the economizer is field-installed and configured, the single or dual enthalpy modes require additional field-provided sensor(s).

11.4.2. Enthalpy Set Point

This setting pertains to the single enthalpy free cooling mode only. The CORE Unit Controller will enable free cooling when outdoor air enthalpy (A7) is less than the enthalpy set point (Parameter 162 - ECON FREECL ENTH SP). Figure 6 shows the approximate enthalpy sensor output at various temperatures and percentage of relative humidity.

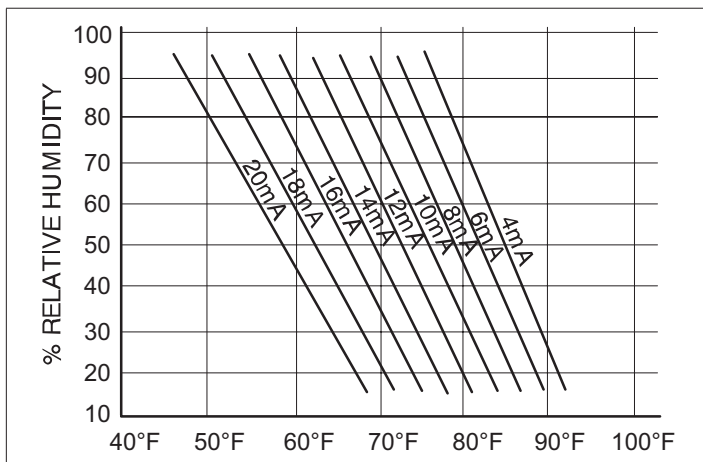

Figure 33. Enthalpy Sensor Output Current Honeywell C7400

11.4.3. Free Cooling Damper Maximum Position

Damper Maximum position for free cooling is by default set to 100%. To modify this settings, use the following path:

SETTINGS > RTU OPTION > EDIT PARAMETER > AIR FLOW > 131 (FREE CL MAX DAMPER)

11.4.4. Minimum Damper Position

Use the following menu path to modified the minimum damper positions for both high and low operations.

SETUP > TEST & BALANCE > DAMPER > CLOSING DAMPER > OPEN DAMPER > TURN BLOWER ON > MIN DAMPER POSITION BLOWER ON HIGH = .%

SETUP > TEST & BALANCE > DAMPER > CLOSING DAMPER > OPEN DAMPER > TURN BLOWER ON > MIN DAMPER POSITION BLOWER ON HIGH = .% > MIN DAMPER POSITION BLOWER ON LOW = .%

11.4.5. Motorized Outdoor Air Damper

Set damper position according to “Minimum Damper Position” section for normal operation, make sure the motorized outdoor air damper is set correctly in Configuration ID 1,

position 2 needs to be set to M. The damper will open to the specified position during the occupied time period and close during the unoccupied time period.

NOTE: When equipped with Motorized Outdoor damper Air Damper, Prodigy 2.0 provides only Demand Control Ventilation. Free Cooling/Economizer function is not available.

11.4.6. Economizer Checkout

The following checkout procedures are completed with unit energized. Confirm proper operation of the heartbeat LED. Step 1 will determine whether the economizer is allowing full damper travel. Use step 2 when the damper does not respond to step 1.

Steps 3, 4, 5, and 6 checkout the operating modes; checkout only the mode that applies to the unit being worked on.

CAUTION

Power exhaust fans will be functional. To prevent operation of power exhaust fans, disconnect power to unit and then PED jack/plug P/J18.

STEP 1. ECONOMIZER OUTPUT VOLTAGE

The CORE Unit Controller monitors P262 (DPOS) and operates as reference in Section Damper Diagnostics in the Prodigy 2.0 (CORE Unit Controller) Application Guide (Advance Features).

Go to SERVICE > COMPONENT TEST > DAMPER > POSITION > DAMPER POSITION > DAMPER POSITION: 0.0%

- a. The motor will slowly modulate to the closed position.
- b. Change DAMPER POSITION ACTUAL to 100.0%.The motor will slowly modulate to the fully opened position.
- c. If the motor does not respond, go to **step 2**. If the motor does respond properly, go to the appropriate mode of operation checkout.

STEP 2. OUTPUT VOLTAGE CHECK

Go to SERVICE > COMPONENT TEST > DAMPER > POSITION > DAMPER POSITION > DAMPER POSITION: 0.0%

- a. Adjust the DAMPER POSITION ACTUAL to 0.0% position.
- b. Measure the voltage on P262 between pin 3 (VOT damper control) and pin 2 (GND) using pin 1 as common. Voltage should read approximately 2 VDC.
- c. Adjust the DAMPER POSITION ACTUAL to 100.0% position.

NOTE: Allow approximately 90 seconds for actuator to react.

- d. Measure the voltage between P262 between pin 3 (VOT damper control) and pin 2 (GND) using pin 1 as common. Voltage should read approximately 10 volts DC. If not, check wiring and trouble shoot system.

STEP 3. SINGLE ENTHALPY OPERATION (ODE)

In the single enthalpy mode, dampers open for free cooling when the outdoor enthalpy is less than the enthalpy set point (Parameter 162 - ECON FREECL ENTH SP); dampers will try to modulate discharge air temperature (RT6) to (Parameter 159 - FREE COOL SUPPLY SP) which has a default setting of 55.0°F (13°C).

- Go to **SETUP > INSTALL >** press **SAVE** until you get to the Configuration ID 1, position 2 needs to be set to **S** for Economizer Single Enthalpy and press **SAVE**.
- To simulate low outdoor enthalpy. Disconnect A7 outdoor enthalpy sensor jack/plugs J/P104. Connect a 750 ohm resistor across plug J104-1 and J104-2. J104 is located in the filter access area.
- Check all connections and wiring between J104 and the control.

STEP 4. DUAL ENTHALPY MODE OF OPERATION

In dual enthalpy mode, dampers open for free cooling when the outdoor air enthalpy is lower than the return air enthalpy by difference value of (Parameter 163 - ECN FRCL ENTH OFFST); dampers will modulate discharge air temperature (RT6) to (Parameter 159 - FREE COOL SUPPLY SP) which has a default setting of 55.0°F (13°C).

- Go to **SETUP > INSTALL >** press **NEXT** until you get to the Configuration ID 1 position 2 needs to be set to D for Economizer Dual Enthalpy and press **SAVE** if performing an economizer field-install.
- Use two resistors to simulate outdoor air enthalpy suitable.
- Disconnect A62 return air enthalpy sensor jack/plug J/P105. Place a 1500 ohm resistor between J105-1 and J105-3. J/P105 is located in the filter access area.
- Disconnect A7 outdoor enthalpy sensor jack/plugs J/P104. Connect a 750 ohm resistor across J104-1 and J104-2.

STEP 5. ALL TEMPERATURE MODES OF OPERATION

In the Economizer – Temperature mode, the damper opens for free cooling when the outdoor air temperature is:

- Less than return air temperature by at least a difference of (Parameter 161 - ECON FRCL TMP OFFST) if Temperature Offset mode is selected
- Less than (Parameter 160 - ECON FREECL TEMP SP)

In all modes, dampers will try to modulate discharge air temperature (RT6) to (Parameter 159 - FREE COOL SUPPLY SP) which has a default setting of 55.0°F (13°C).

Refer to the “Displaying Sensor Inputs” section to read return air (RT16) and outdoor air (RT17) temperatures. If outdoor air is not cooler than return air, simulate a colder outdoor air temperature with a resistor. Select a resistor value that corresponds to a temperature:

- Locate RT17 sensor in unit. Disconnect 1/4” quick connect terminals on wires leading from sensor.
- Jumper RT17 wires leading back to control with the appropriate resistor.
- Check all connections and wiring between RT17 and the CORE Unit Controller, and between RT16 and the CORE Unit Controller.

Table 8. TMP Mode Resistor Values

Temp. °F (°C)	Size Resistor	Temp. °F (°C)	Size Resistor	Temp. °F (°C)	Size Resistor	Temp. °F (°C)	Size Resistor
30 (-1)	34,566	50 (10)	19,904	70 (21)	11,884	90 (32)	7,332
40 (4)	26,106	60 (16)	15,313	80 (27)	9,298	100 (38)	5,826

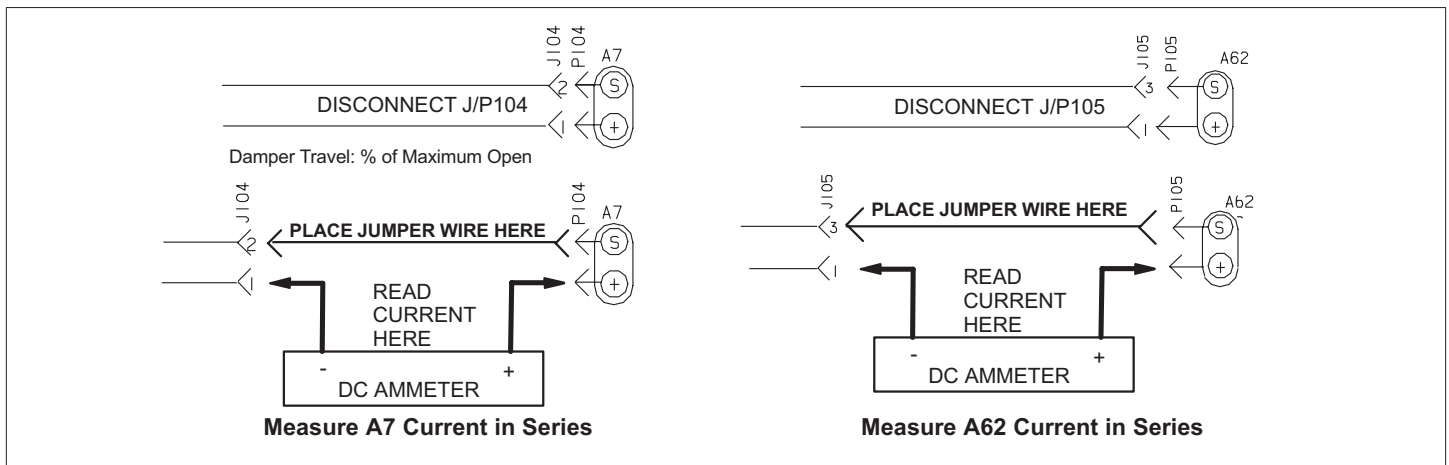

Figure 34. Measure A7 and A62 Current in Series

STEP 6. GLOBAL MODULATING (GLO) MODE OF OPERATION

In the GLO (modulating) mode, dampers modulate open for free cooling when the global input is energized; dampers will try to modulate discharge air temperature (RT6) to (Parameter 159 - FREE COOL SUPPLY SP) which has a default setting of 55.0°F (13°C).

NOTE: *The global input turns on the blower.*

- a. Set global mode using the Configuration ID 1, position 2, and set to character G.
- b. Connect a jumper between A55_P297-1 (24VAC) and A55_P297-9 (global). The blower is energized and the damper will slowly open if discharge air temperature (RT6) is greater than (Parameter 159 - FREE COOL SUPPLY SP) which has a default setting of 55.0°F (13°C).
- c. Disconnect 24VAC to A55_P297-9. The blower will turn off and the damper will close.
- d. If the damper does not actuate then check all connections and wiring between P262A and B.

STEP 7. ENTHALPY SENSOR OPERATION (A7 AND A62)

If enthalpy sensors are configured, current sensor reading by CORE Unit Controller can be verified through the user interface:

- a. Connect a direct current ammeter as shown in figure 4 to measure current output of A7 or A62.
- b. The reading will be between (4 and 20 ma.) and depends on outdoor temperature and humidity. Refer to figure 3 to approximate reading.

Go to DATA > SYSTEM DATA / SENSORS / OUTPUTS > LOCAL INPUTS > SENSORS > LOCAL
(scroll down to INDOOR AND OUTDOOR ENTHALPY)

- c. If the meter reads zero, check sensor wiring harness for continuity and/or check polarity of sensor wiring.

11.5. Demand Control Ventilation

A field-provided and installed indoor air quality (IAQ) sensor can be used with the modulating economizer or OADM to control carbon dioxide levels in the conditioned space. The carbon dioxide level in a space is an indicator of the number of people occupying a room. As the carbon dioxide level rises (indicating the occupancy of a room has increased), dampers modulate open - regardless of outdoor air suitability. Likewise, as the carbon dioxide level falls (indicating the occupancy has decreased), dampers modulate further closed.

Standard economizer installations have a minimum fresh air ventilation requirement based on maximum room occupancy. With standard economizer use, the amount of air required for maximum room occupancy is heated or cooled with each heating or cooling cycle. IAQ installations use the maximum amount of required ventilation air only with maximum room occupancy; less outdoor air needs to be heated or cooled when fewer people are in the conditioned space.

If the economizer is operating in the free cooling mode and the indoor air quality control requires the damper to open further, the indoor air quality demand will override the free cooling demand.

The IAQ function is not energized during the unoccupied or night time period.

NOTE: *The IAQ sensor may also be used with systems containing a motorized outdoor air damper.*

11.5.1. Default Operation

The CORE Unit Controller has a 0-10VDC indoor air quality input for a standard 0 - 2000ppm carbon dioxide sensor. The economizer starts opening at a carbon dioxide level of 700 ppm (default) (start open set point) and reaches full open at a carbon dioxide level of 1200ppm (default) (full open set point).

The damper opens to a default position of 50% (see Parameter 117). Determine damper travel position using the following formula:

$$\% \text{ Damper Travel} = \frac{\text{carbon dioxide ppm} - \text{Start Open ppm}}{5}$$

Example: At a carbon dioxide level of 750ppm, the damper will be approximately 50% open:

$$\% \text{ Damper Travel} = \frac{750 - 500}{5} = 50\%$$

Use the menu interface to read carbon dioxide ppm.

Go to DATA > SYSTEM DATA / SENSORS / OUTPUTS > LOCAL INPUTS > SENSORS > LOCAL
(scroll down to CO₂)

11.5.2. Maximum and Minimum Demand Control Ventilation Damper Settings

Maximum position is set using the following menu path:

Go to SETTINGS > RTU OPTIONS > DAMPER > SET ECONOMIZER OPTION > SET FREE COOLING SUPPLY AIR SETPOINT > CLOSE DAMPER > OPEN DAMPER > TURN ON BLOWER > MINIMUM DAMPER POSITION > and select DEMAND CONTROL VENTILATION.

Options are:

- DEMAND CONTROL VENT > DAMPER START OPEN = XXXX PPM
- DEMAND CONTROL VENT > DAMPER FULL OPEN = XXXX PPM
- DEMAND CONTROL VENT > DAMPER MAX OA CFM = X CFM (only visible if configuration id 1, position 2 is set correctly).
- DEMAND CONTROL VENT > DAMPER MAX OPEN = XXX.X %.

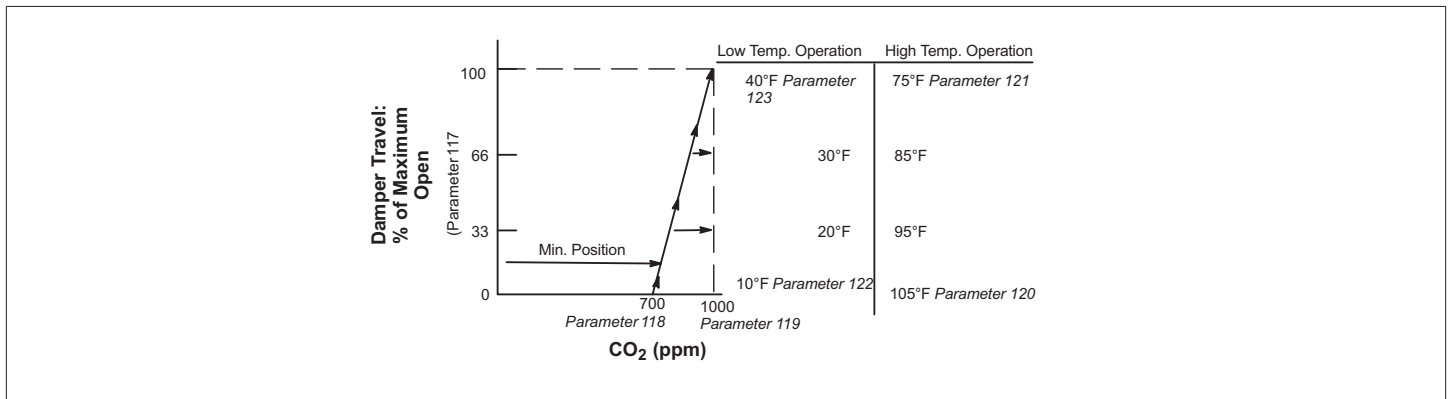

Figure 35. Default Demand Control Ventilation (DCV) Operation

11.5.3. Parameter Adjustments

Default indoor air quality economizer operation is based on common or average applications. Adjustments may be made to the indoor air quality Parameters to alter operation or meet required specifications. Use the user interface to change Parameter 117 through 123.

Go to **SETTINGS > RTU OPTIONS > EDIT PARAMETER > IAQ INPUT MODE**

Select a demand control ventilation mode with Parameter 134. Modes 3 and 4 will bring on the unit blower when demand control ventilation calls for maximum damper open, and returns to auto-blower when demand control ventilation damper returns to 0. The other modes only operate when the unit blower is on, but will not bring it on themselves.

Some applications require a different carbon dioxide set point range than default settings. Damper start open (Parameter 118) and full open (Parameter 119) carbon dioxide set points may be adjusted from 0 to 2000 ppm. Use the following formula to determine damper travel.

NOTE: When changing carbon dioxide set point range, “start open” set point should be less than “full-open” set point.

% Damper Travel = $\frac{\text{carbon dioxide ppm} - \text{Start Open ppm}}{\text{Full Open} - \text{Start Open}} \times \text{Max Open (Parameter 117)}$

Example: An application requires the dampers open at 800 CO2 ppm and reach full open at 1200. If the carbon dioxide level in the space reads 1000 ppm, calculate the damper percent open as follows.

$$\% \text{ Damper Travel} = \frac{1000 - 800}{1200 - 800} \text{ or } \frac{200}{400} \text{ or } .5 = 0.5 \times 100 = 50\%$$

11.5.4. Set Point Control Option

Set point control mode is commonly used in areas with high occupancy and frequent change out such as classrooms or conference rooms.

In applications requiring this on/off damper response to airborne dioxide levels, set the start open (Parameter 118 - DCV DAMP START OPEN) set point higher than the full open (Parameter 119 - DCV DAMP FULL OPEN) set point. The dampers will drive to fully-open position immediately. Figure 6 shows the set point control option. Change Parameters 122 and 123 to set the minimum outdoor temperature limits.

Change Parameters 120 and 121 to set the maximum temperature limits.

IMPORTANT

Mixed air temperatures less than 45°F (7°C) on units with an aluminized heat exchanger or less than 30°F (-1°C) on stainless steel heat exchangers will void the manufacturer’s warranty.

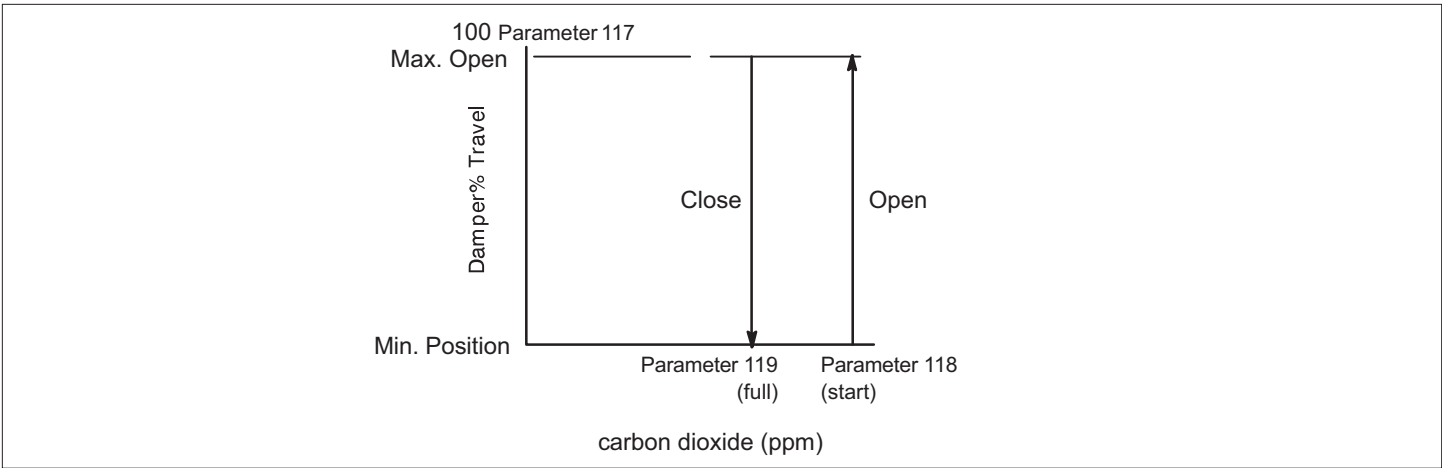

Figure 36. Set point Control Indoor Air Quality Option

11.6. Determining Indoor Air Quality Inputs

Selection from the CORE Unit Controller menu display.

Go to DATA > SYSTEM DATA / SENSORS / OUTPUTS > LOCAL INPUTS > SENSORS

11.7. BACNET

- The configuration shown in figure 37 has terminations on the CORE Unit Controller BACnet modules at both ends and ONLY at both ends of the chain.
- The configuration shown to the in figure 37 has a termination at the controller/router on one end and a termination at the CORE Unit Controller BACnet module on the other end; terminations are ONLY at the ends of the chain.
- Cable type - twisted pair with shield, 22 awg minimum, Belden #88761 or #8761 (Lennox 27M19, 94L63, 68M35).

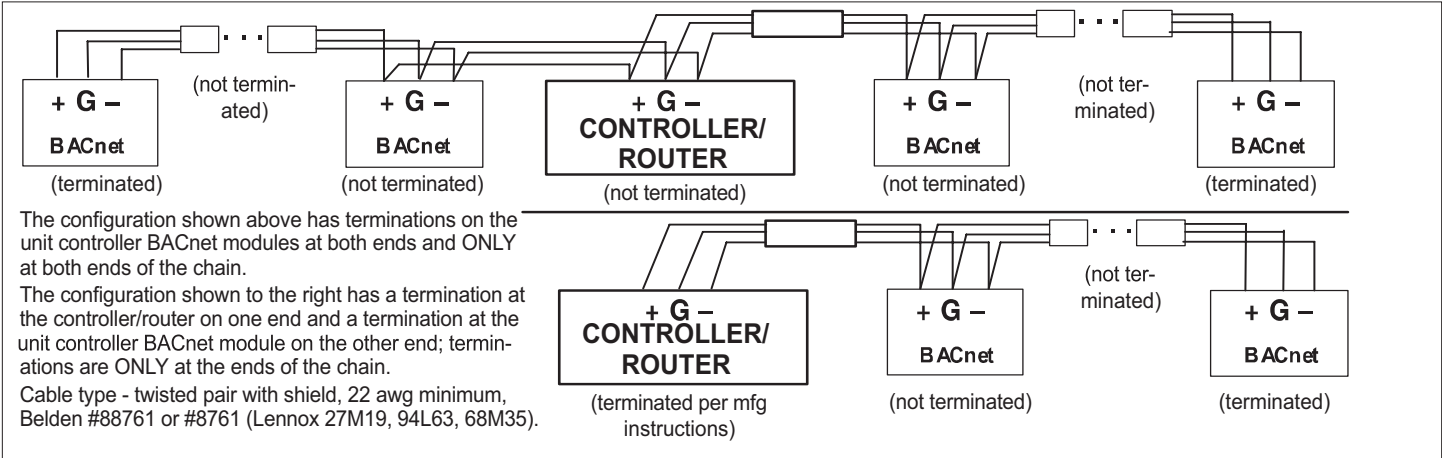

Figure 37. Terminating Ends of a Daisy-Chained Network

11.8. Abbreviations

Table 9. Abbreviations

Abbreviation	Definition
A55	M3 board. Main RTU control board
AI	Analog input
AO	Analog output
BL	Blower
C3	Add on board for third and fourth compressor and second-stage heat (A178).
C1	1st stage cooling
C2	2nd stage cooling
C3	3rd stage cooling
C4	4th stage cooling
CAI	Combustion air inducer
CAVB	Constant air volume with bypass damper
COM	Electrical common
CL	Cooling
CP1	Compressor 1
CP2	Compressor 2
CP3	Compressor 3
CP4	Compressor 4
CSP	Cooling setpoint
DAC	Discharge (supply) air control
DACC	Discharge (supply) air control cooling
DACH	Discharge (supply) air control heating
DAP	Discharge (supply) air pressure
DAT	Discharge (supply) air temperature
DB	Deadband
DCV	Demand controlled ventilation
DDC	Direct digital control
DI	Digital input
Diff	Differential
DO	Digital output
FAC	Fresh air cooling control
FAH	Fresh air heating control
FAT	Fresh air tempering control. See FAC & FAH
FC	Free cooling
G	Thermostat demand, blower
GLO	Global mode or input (economizer)
H1	1st stage heating
H2	2nd stage heating
H3	3rd stage heating
H4	4th stage heating
HP	High pressure
HSP	Heating setpoint
HT	Heating
IAQ	Indoor air quality. Often synonymous with CO2 level in ppm
IDE	Indoor enthalpy. Depends on temperature and humidity
“w.c.”	Inches of water column

Table 9. Abbreviations

Abbreviation	Definition
LED	Light emitting diode. An indicator light, found either as individual elements or grouped together as segments to form characters
LP	Low pressure
LT	Limit
M4	CORE Unit Controller - main controller board (A55)
MGV	Modulating gas valve
MSAV	Multi Stage Air Volume
OAC	Outdoor air control
OAS	Outdoor air suitable for free cooling
OAT	Outdoor air temperature
OCP	Thermostat demand, occupied mode
ODE	Outdoor enthalpy. Depends on temperature and humidity
PID	Proportional, integral and derivative based control loop
PPM	Parts per million (mostly used for CO2 measurements)
RAP	Return air pressure
RAT	Return air temperature
RH	Relative humidity
RS	Reset
RTU	Roof top unit
RT6	Discharge air temperature sensor
RT16	Return air temperature sensor
RT17	Outdoor air temperature sensor
SMK	Smoke detection mode (alarm)
SP	Setpoint
Stg	Stage
TB	Terminal block
UnOCP	Unoccupied
W1	Thermostat demand, heat stage 1
W2	Thermostat demand, heat stage 2
W3	Thermostat demand, heat stage 3
W4	Thermostat demand, heat stage 4
VAC	Alternating current voltage
VAV	Variable air volume. Accomplished with a variable frequency drive (VFD)
VDC	Direct current voltage
VFD	Var. frequency drive. An AC inverter used to vary motor speed
VT	Ventilation
Y1	Thermostat demand, cooling stage one
Y2	Thermostat demand, cooling stage two
Y3	Thermostat demand, cooling stage three
Y4	Thermostat demand, cooling stage four
ZAT	Zone air temperature

12. Parts and Kits

Table 10. Parts and Kits Available for CORE Unit Controller

Description	Catalog number	Description	Catalog number	Description	Catalog number
CORE Unit Controller Replacement kit	14V60	USB service kit tube	59W52	SmartWire™ Field Termination kit	59W57
LCD Display Replacement Kit	10X85	CORE Unit Controller battery (10-pack)	59W53	Lennox Prodigy 2.0 USB Memory Stick (5-pack)	59W59
CORE Unit Controller cover	10X86	BACnet Replacement kit	59W51		

13. Service Report Example

```

=====
USB SERVICE REPORT
=====
Service Date      04:03:2014
Service Time     19:26:35
Serial No.
Software Version 08.00.0009
Hardware Version
Unit Number      UNIT 1
SBUS Address     2
BACnet Address  2
Catalogue Number
Model Number     LGH060H4EH1Y
CONFIGURATION ID 1 NNNNNNLN
CONFIGURATION ID 2 NNNNNNNN
Status           IDLE
=====
Runtime Data
Total Power On   23 HRS      8 CYCLES
Before Install  0 HRS      -----
Filter          12 HRS      -----
Belt            11 HRS      -----
Blower         12 HRS      50 CYCLES
Compressor 1    3 HRS      40 CYCLES
Compressor 2    4 HRS      27 CYCLES
Compressor 3    0 HRS      2 CYCLES
Compressor 4    0 HRS      3 CYCLES
Outdoor Fan 1   7 HRS      28 CYCLES
Outdoor Fan 2   2 HRS      22 CYCLES
Outdoor Fan 3   0 HRS      2 CYCLES
Outdoor Fan 4   0 HRS      3 CYCLES
Outdoor Fan 5   0 HRS      3 CYCLES
Outdoor Fan 6   0 HRS      3 CYCLES
POWER EXHAUST  0 HRS      0 CYCLES
Heat Stage 1    0 HRS      1 CYCLES
Heat Stage 2    0 HRS      1 CYCLES
Humiditrol     0 HRS      0 CYCLES
Free Cooling   0 HRS      4 CYCLES
UV Lamp        0 HRS      -----
=====
Sensor Data
OAT      66 degF
RAT      72 degF
DAT      73 degF
ZAT      78 degF
RH       50 %
CO2     460 ppm
=====
SmartAirFlow System Data
Calibrated On 04/03/2014 19:12:56

Supply Airflow Calibration Table
-----
PWM(%)   Speed(rpm)   Airflow(cfm)
-----
20        480           1031
30        570           1274
40        660           1493
50        750           1687
60        840           1857
70        930           2004
80       1020           2126
90       1110           2223
100      1200           2297

Supply Airflow Targets
-----
Mode           Desired Airflow(cfm)   PWM(%)
-----
=====
Cool High      1800      57
Cool Low      1300      31
Heat          2000      70
Ventilation    1200      27
Smoke         2000      70
Economizer Differential Pressure(@ 2000 Supply
Airflow(cfm))
-----
Dampner Position (%)   Diff.Pressure(in.H2O)
-----
0                       0.39
50                      0.23
100                     0.06

Outside Airflow Targets
-----
Minimum Outside Air/Minimum DCV: 200 cfm
Maximum DCV: 0 cfm
Minimum CO2: 700 ppm
Maximum CO2: 1200 ppm
=====
Alarm/Status Log
(143) 04:03:2014 19:26:13 RESET DAMPER PRESSURE
(141) 04:03:2014 19:26:13 RESET CFM TARGET TOO
HIGH
(143) 04:03:2014 19:06:19 SET DAMPER PRESSURE
(141) 04:03:2014 19:06:19 SET CFM TARGET TOO
HIGH
( 82) 04:03:2014 19:06:18 RESET CONTROLLER RESET
( 82) 04:03:2014 19:06:18 SET CONTROLLER RESET
(143) 04:03:2014 18:59:41 SET DAMPER PRESSURE
(141) 04:03:2014 18:59:41 SET CFM TARGET TOO
HIGH
( 82) 04:03:2014 18:59:40 RESET CONTROLLER RESET
( 82) 04:03:2014 18:59:40 SET CONTROLLER RESET
(143) 04:03:2014 18:35:19 SET DAMPER PRESSURE
(141) 04:03:2014 18:35:19 SET CFM TARGET TOO
HIGH
(148) 04:03:2014 18:21:36 RESET SMART AIRFLOW
CONFIG ERROR
(170) 04:03:2014 18:21:36 RESET POWER EXHAUST
UNCONFIGURED
(165) 04:03:2014 18:21:36 RESET ECONOMIZER
UNCONFIGURED
( 85) 04:03:2014 18:21:36 RESET INCORRECT
HUMIDITROL SETTINGS
(132) 04:03:2014 18:21:24 RESET VFD BYPASS
UNCONFIGURED
(148) 04:03:2014 18:21:23 SET SMART AIRFLOW
CONFIG ERROR
(132) 04:03:2014 18:21:23 SET VFD BYPASS
UNCONFIGURED
(170) 04:03:2014 18:21:23 SET POWER EXHAUST
UNCONFIGURED
(165) 04:03:2014 18:21:23 SET ECONOMIZER
UNCONFIGURED
( 85) 04:03:2014 18:21:23 SET INCORRECT
HUMIDITROL SETTINGS
( 82) 04:03:2014 18:20:31 RESET CONTROLLER RESET
( 82) 04:03:2014 18:20:31 SET CONTROLLER RESET
( 82) 04:03:2014 18:16:32 RESET CONTROLLER RESET
( 82) 04:03:2014 18:16:32 SET CONTROLLER RESET
( 82) 04:03:2014 18:14:10 RESET CONTROLLER RESET
( 82) 04:03:2014 18:14:10 SET CONTROLLER RESET
( 82) 04:03:2014 18:14:09 RESET CONTROLLER RESET
( 82) 04:03:2014 18:14:09 SET CONTROLLER RESET
=====
END OF REPORT
=====

```

14. Alarms

14.1. Phase - Voltage Detection

The CORE Unit Controller has the ability to detect that the rooftop unit power source has the correct frequency, phasing and voltage levels. When this feature is enabled, the detection of frequency and phasing is determined at power-on and the voltage level is continuously monitored. If any of these is out of range, then an alarm is logged and the rooftop unit operation is locked out.

a. Alarms Detected at Power-On Start up:

- 121 - LINE FREQ DOES NOT MATCH UNIT CONFIG
- 126 - LINE PHASING DOES NOT MATCH UNIT CONFIG

b. Alarms - Continuously Monitoring

- 122 - 24VAC PRIMARY VOLTAGE LOW
- 123 - 24VAC PRIMARY VOLTAGE HIGH
- 134 - 24VAC SECONDARY VOLTAGE LOW
- 125 - 24VAC SECONDARY VOLTAGE HIGH

Alarms 122 through 125 are auto-resetting. The rooftop operation will be restored five (5) minutes after the proper voltage levels are restored. Alarms 121 and 126 requires removing the power and correcting the issue before restoring the rooftop operation.

The frequency (60 or 50 Hz) and the phasing (single or three-phase) of the power source is determined by the model number stored in the CORE Unit Controller. This model number and enabling/disabling the Phase-Voltage Detection feature can be modified through the CORE Unit Controller user interface. See the Installation and Setup Guide for instructions on how to configure the CONFIGURATION ID 2, Position 5. Options are:

- N = NOT INSTALLED
- 1 = ENABLED INTERNAL (LENNOX)
- 2 = EXTERNAL (A42) PHASE DETECTION ON DI-2
- 3 = EXTERNAL (A42) PHASE DETECTION ON DI-3

When an event occurs, the CORE Unit Controller will display a code which corresponds to control function. Error codes are stored and can be recalled later.

NOTE: Any references in the user interface referencing *Advanced Airflow* actually indicates *SmartAirflow*®.

14.2. Service Relays

Selected alarms (marked with * in the following table result in the closure of the service relay contacts (DO1). The contacts remain closed until the CORE Unit Controller resets, or alarm condition is cleared and alarm status is read via explicit S-BUS command. Other modes of operation may be selected and are described in the CORE Unit Controller Application Guide (Advanced Features).

NOTE: Any references in the user interface referencing *Advance Airflow* actually indicates *SmartAirflow*®.

14.3. CORE Unit Controller Alarm and Event Codes

Table 11. CORE Control System Alarm and Event Codes

SELECTED ALARMS (MARKED WITH * IN TABLE RESULT IN THE CLOSURE OF THE SERVICE RELAY CONTACTS (DO1).		
ALARM CODE	DISPLAY MESSAGE	EVENT ACTION
1	ERRATIC POWER (single phase units)	Power loss for two cycles. This may indicate that the unit power is dirty or is of low quality. Check power connections. The CORE Unit Controller will set an alarm "Erratic Power" whenever service is turned off due to detection of power loss. User will be able to clear "Erratic Power" alarm via user interface. The CORE Unit Controller will clear "Power Erratic" after the Compressor Min OFF Delay has expired. If compressor demand is still present the CORE Unit Controller will restart compressor(s) after the Compressor Min OFF Delay has expired.
2	PARAMETER ACCESS ERROR	Parameter access error. This may indicate a problem with the Parameter memory chip and parameters may not be changeable.
3	RESERVED	
4*	SMOKE DETECTED	A173 input is sensed as closed. Will automatically clears once input is detected open. For smoke mode, check for source of smoke. While Smoke Alarm is active, the CORE Unit Controller will not service any cooling, heating or ventilation demands.

Table 11. CORE Control System Alarm and Event Codes

SELECTED ALARMS (MARKED WITH * IN TABLE RESULT IN THE CLOSURE OF THE SERVICE RELAY CONTACTS (DO1).		
ALARM CODE	DISPLAY MESSAGE	EVENT ACTION
5*	BLOWER - NO AIR FLOW DETECTED	Unit off. Air flow switch is normally closed. Monitoring starts 16 seconds after blower is started. If air flow switch is detected open after 16 second delay period, all compressors are de-energized, gas valves closed, electric heat turned off, economizer damper closed, and blower is stopped. Alarm will automatically clear once the error timed off delay has expired and system will resume. Check blower operation.
6*	DIRTY AIR FILTER	Dirty filter switch is detected as closed and will automatically clear once switch is detected open. Replace filter or check filter switch S27.
7	EXTERNAL EEPROM WRITE ERROR	
8*	STRIKE 3 ON BLOWER	Lockout is active with multiple alarm code 5 detected. Alarm can be manually cleared through the user interface. Check blower operation. Once problem is corrected, lockout alarm can be cleared by resetting the CORE Unit Controller.
9	RESERVED	
10	24VAC POWER LOSS TB35-1	24 VAC power loss at TB35-1 on A55 (M1) board. P111 pin 11.
11	24VAC POWER LOSS TB34-1	24 VAC power loss at TB34-1 on A55 (M1) board. P113 pin 1.
12	HIGH PRESS S4 OPEN COMP1	Compressor is off. Check charge, fans and coil. NOTE: On Ultra-High Efficiency units - if only alarm 12 is present then issue could be high temperature S5 switch. If alarm 12 is accompanied with alarm 14 then most likely it is the high pressure S4 switch. The unit controller will clear high pressure switch alarm when corresponding high pressure switch is detected as closed. Compressor will not restart until corresponding high pressure switch is closed and Minimum Off Delay (cooling or heating) has expired.
13*	STRIKE3 HIGH PRESS S4 OPEN COMP1	<ul style="list-style-type: none"> Compressor is lockout. Check charge, fans and coil. Use service menu to clear lockouts. User will be able to clear high pressure switch compressor lockout and alarm via user interface. High pressure switch compressor lockout and alarm will be cleared after the CORE Unit Controller reset. High pressure switch compressor lockout and alarm will be cleared on termination of cooling demand. Default is 3 occurrences and can be set between 1 and 7 occurrences.
14	HIGH PRESS S7 OPEN COMP2	Compress is off. Check charge, fans or coil. This feature is not support in Model L at this time. NOTE: On Ultra-High efficiency units tandem alarms (14) compressor 2 high temperature S8 switch. If accompanied with alarm 15 then most likely the S4 high pressure switch is the issue. The CORE Unit Controller will clear high pressure switch alarm when corresponding high pressure switch is detected as closed. Compressor will not be restarted until corresponding high pressure switch is closed and Minimum Off Delay (cooling or heating) has expired.
15*	STRIKE3 HIGH PRESS S7 OPEN COMP2	<ul style="list-style-type: none"> Compressor lockout. Check charge, fans and coil. Use service menu to clear lockouts. User will be able to clear high pressure switch compressor lockout and alarm via user interface. High pressure switch compressor lockout and alarm will be cleared after the CORE Unit Controller reset. High pressure switch compressor lockout and alarm will be cleared on removal of cooling demand. Default is 3 occurrences and can be set between 1 and 7 occurrences.
16	HIGH PRESS S28 OPEN COMP3	<ul style="list-style-type: none"> Compressor is off. Check charge, fans and coil. The CORE Unit Controller will clear high pressure switch alarm when corresponding high pressure switch is detected as closed. Compressor will not be restarted until corresponding high pressure switch is closed and Minimum Off Delay (cooling or heating) has expired.
17*	STRIKE3 HIGH PRESS S28 OPEN COMP3	<ul style="list-style-type: none"> Compressor lockout. Check charge, fans and coil. Use CORE Service application RTU > SERVICE menu to clear lockouts. User will be able to clear high pressure switch compressor lockout and alarm through the user interface. High pressure switch compressor lockout and alarm will be cleared after the CORE Unit Controller reset. High pressure switch compressor lockout and alarm is cleared on removal of cooling demand. Default is 3 occurrences and can be set between 1 and 7 occurrences.

Table 11. CORE Control System Alarm and Event Codes

SELECTED ALARMS (MARKED WITH * IN TABLE RESULT IN THE CLOSURE OF THE SERVICE RELAY CONTACTS (DO1).		
ALARM CODE	DISPLAY MESSAGE	EVENT ACTION
18	HIGH PRESS S96 OPEN COMP4	<ul style="list-style-type: none"> Compressor lockout. Check charge, fans and coil. The CORE Unit Controller will clear high pressure switch alarm when corresponding high pressure switch is detected as closed. Compressor will not be restarted until corresponding high pressure switch is closed and Minimum Off Delay (cooling or heating) has expired.
19*	STRIKE3 HIGH PRESS S96 OPEN COMP4	<ul style="list-style-type: none"> Compressor lockout. Check charge, fans and coil. Use service menu to clear lockouts. User will be able to clear high pressure switch compressor lockout and alarm via user interface. High pressure switch compressor lockout and alarm will be cleared after the CORE Unit Controller reset. High pressure switch compressor lockout and alarm is cleared on removal of cooling demand. Default is 3 occurrences and can be set between 1 and 7 occurrences.
NOTE: EVENTS 12 THROUGH 19 COULD ALSO BE CAUSED BY A HIGH TEMPERATURE CONDITION ON SOME COMPRESSORS EQUIPPED WITH A HIGH TEMPERATURE SHUTDOWN.		
20	PHASE MONITOR FAULT	Phase monitor or blower motor overload switch or inverter fault output or condensate overflow switch is indicating an issue.
21	STRIKE 3 PHASE MONITOR FAULT	
22	LOW PRESS S87 OPEN COMP1	Compressor is off. Check charge, fans and coil. Use service menu to clear lockouts.
23*	STRIKE3 LOW PRESS S87 OPEN COMP1	<ul style="list-style-type: none"> Compressor is off. Check charge, fans and coil. Use service menu to clear lockouts. Number of occurrences is set using Parameter 99 (max lo occurrences). Default is 3 occurrences.
24	LOW PRESS S88 OPEN COMP	Compressor is off. Check charge, fans and coil.
25*	STRIKE3 LOW PRESS S88 OPEN COMP2	<ul style="list-style-type: none"> Compressor is off. Check charge, fans and coil. Use service menu to clear lockouts. Number of occurrences is set using Parameter 99 (max lo occurrences). Default is 3 occurrences.
26	LOW PRESS S98 OPEN COMP	Compressor if off. Check charge, fans and coil.
27*	STRIKE3 LOW PRESS S98 OPEN COMP3	<ul style="list-style-type: none"> Compressor is off. Check charge, fans and coil. Use service menu to clear lockouts. Number of occurrences is set using Parameter 99 (max lo occurrences). Default is 3 occurrences.
28	LOW PRESS S97 OPEN COMP	Compressor if off. Check charge, fans and coil.
29*	STRIKE3 LOW PRESS S97 OPEN COMP4	<ul style="list-style-type: none"> Compressor is off. Check charge, fans and coil. Use service menu to clear lockouts. Number of occurrences is set using Parameter 99 (max lo occurrences). Default is 3 occurrences.
30*	OVERFLOW SWITCH	<ul style="list-style-type: none"> Check for block drain, condensate lines and drain pan overflow switch. Alarm set if overflow switch is detected opened and compressor will be locked out. System will automatically clear alarm once switch is detected closed. System will resume operation (compressor lockout), after the Error Timed OFF Delay has expired following the Overflow switch alarm clear.
31	STRIKE3 UNIT SHUTDOWN S149	S149 input is open, condensate overflow switch; multiple times.
32	FRZ STAT S49 OPEN COMP1	Compressor is off. Check freezestat, air flow, charge, coil, air filter and outside air temperature.
33*	STRIKE3 FRZ STAT S49 OPEN COMP1	<ul style="list-style-type: none"> Compressor is locked out. Check freezestat, air flow, charge, coil, air filter and outside air temperature. Number of occurrences is set using Parameter 81 (max freeze sat occ). Default is 3 occurrences.
34	FRZ STAT S50 OPEN COMP2	Compressor is locked out. Check freezestat, air flow, charge, coil, air filter and outside air temperature.
35*	STRIKE3 FRZ STAT S50 OPEN COMP2	<ul style="list-style-type: none"> Compressor is locked out. Check freezestat, air flow, charge, coil, air filter and outside air temperature. Number of occurrences is set using Parameter 81 (max freeze sat occ). Default is 3 occurrences.
36	FRZ STAT S53 OPEN COMP3	Compressor is locked out. Check freezestat, air flow, charge, coil, air filter and outside air temperature.

Table 11. CORE Control System Alarm and Event Codes

SELECTED ALARMS (MARKED WITH * IN TABLE RESULT IN THE CLOSURE OF THE SERVICE RELAY CONTACTS (DO1).		
ALARM CODE	DISPLAY MESSAGE	EVENT ACTION
37*	STRIKE3 FRZ STAT S53 OPEN COMP3	<ul style="list-style-type: none"> Compressor is locked out. Check freezestat, air flow, charge, coil, air filter and outside air temperature. Number of occurrences is set using Parameter 81 (max freeze sat occ). Default is 3 occurrences.
38	FRZ STAT S95 OPEN COMP4	<ul style="list-style-type: none"> Compressor is locked out. Check freezestat, air flow, charge, coil, air filter and outside air temperature.
39*	STRIKE3 FRZ STAT S95 OPEN COMP4	<ul style="list-style-type: none"> Compressor is locked out. Check freezestat, air flow, charge, coil, air filter and outside air temperature. Number of occurrences is set using Parameter 81 (max freeze sat occ). Default is 3 occurrences.
40	RETURN AIR OVER HEAT LIMIT	Heat is above set point. Check space conditions and sensors.
41	RETURN AIR UNDER COOL LIMIT	Cool is below set point. Check space conditions and sensors.
42*	BLOWER MOTOR OVERLOAD	<ul style="list-style-type: none"> System will set an alarm if S42 witch is detected as open. System will automatically clear alarm once S42 switch is detected closed. System will resume operation (servicing the demands), after the Error Timed OFF Delay has expired following S42 or S135 clear. Check external motor overloads.
43	STRIKE3 UNIT SHUTDOWN S42 OR S135	S42/ S135 Motor Overload multiple times.
44*	GAS VALVE ON NO DEMAND GV1	Unit is off. Gas valve 1 has power, but no demand. Check gas valve and wiring.
45*	GAS VALVE ON NO DEMAND GV2	Unit is off. Gas valve 2 has power, but no demand. Check gas valve and wiring.
46	NO 24VAC POWER ON A60	No 24VAC relay power on A60 (E1) board, K9-5 input. (A60)
47	NO 24VAC POWER ON A58	No 24VAC relay power on A58 (G1) board, TB35-1 input. (A58)
48	NO 24VAC POWER ON A61	No 24VAC relay power on A61(HP1) board, TB34-1 input. (A61)
49	NO 24VAC RELAY POWER ON C3 A59	Third and fourth compressors are off. Alarm automatically clears once 24VAC is present. The CORE Unit Controller will resume operation once the ERROR TIME OFF DELAY is completed. Parameter 110 is used to set the reference delay. Factory delay default is 300 seconds.
50	PRIMARY HEAT1 LIMIT OPEN S10	Heat section 1 primary gas heat limit switch is open. Check air flow, air filter, limit switch and wiring.
51*	STRIKE3 PRIMARY HEAT1 LIMIT OPEN S10	Heat section 1 primary gas heat limit switch is open. Check air flow, air filter, limit switch and wiring. Number of occurrences is reached.
52	SECONDARY HEAT1 LIMIT OPEN S21	Heat section 1 secondary gas heat limit switch is open. Check air flow, air filter, limit switch and wiring.
53*	STRIKE3 SECONDARY HEAT1 LIMIT OPEN S21	Heat section 1 secondary gas heat limit switch is open. Check air flow, air filter, limit switch and wiring. Number of occurrences is reached.
54	HEAT1 S15 LIMIT OR ROLLOUT OPEN	Heat section 1 primary electric heat limit switch is open. Check air flow, air filter, limit switch and wiring.
55*	STRIKE3 HEAT1 S15 LIMIT OR ROLLOUT OPEN	Heat section 1 flame roll out burner 1 switch is open. Check gas roll out switch S47.
56	HEAT1 CAI SW S18	Check heat section 1 combustion air motor and proof switch.
57*	STRIKE3 HEAT1 CAI SW S18	Check heat section 1 combustion air motor and proof switch. Number of occurrences is reached.
58*	HEAT1 NO PROOF GV1	Check heat section 1 ignition control, flame proof, gas valve 1 and gas supply.
59*	NO FLAME PROOF AFTER TRIALS GV1	Check heat section 1 ignition control, flame proof, gas valve 1 and gas supply. Number of occurrences is reached.
60	PRIMARY HEAT2 LIMIT OPEN S99	Check heat section 2 primary burner limit switch to see if it is open. Check air flow, limit switch and wiring.
61*	STRIKE3 PRIMARY HEAT2 LIMIT OPEN S99	Check heat section 2 primary burner limit switch to see if it is open. Check air flow, limit switch and wiring. Number of occurrences is reached.
62	SECONDARY HEAT2 LIMIT OPEN S100	Heat section 2 secondary heat limit switch is open. Check air flow, limit switch and wiring.
63*	STRIKE3 SEC HEAT2 LIMIT OPEN S100	Heat section 2 secondary heat limit switch is open. Check air flow, limit switch and wiring. Number of occurrences is reached.
64	HEAT2 ROLL OUT OPEN	Flames have been detected outside the gas heater's fire box.
65*	STRIKE3 HEAT2 ROLL OUT OPEN	Check roll out sensor and gas supply.
66	HEAT2 CAI SW	Check heat section 2 combustion air motor and proof switch.

Table 11. CORE Control System Alarm and Event Codes

SELECTED ALARMS (MARKED WITH * IN TABLE RESULT IN THE CLOSURE OF THE SERVICE RELAY CONTACTS (DO1).		
ALARM CODE	DISPLAY MESSAGE	EVENT ACTION
67*	STRIKE3 HEAT2 CAI SW S45	Check heat section 2 combustion air motor and proof switch. Number of occurrences is reached.
68*	HEAT2 NO PROOF GV2	Check heat section 2 ignition control, flame roof, gas valve 2 and gas supply.
69*	NO FLAME PROOF AFTER TRIALS GV2	Check heat section 2 ignition control, flame roof, gas valve 2 and gas supply. Number of occurrences is reached.
70 - 72 RESERVED		
73	NETWORK SENSOR	Check with integrator for refresh rate, network status lights and wiring.
74*	ZONE SENSOR	<ul style="list-style-type: none"> If measurement is out of specified range (including open/short detection) the system will ignore the Zone Temperature Sensor readings and set the alarm. If measurement of Zone Temperature Sensor is out of specified range (including open/short detection) the system will change operating mode to the specified Backup mode (None, Local Thermistor or Return Air temp). The system will clear the alarm, if zone temperature sensor measurement is detected in specified operating range and return the system to monitoring the A2 sensor as the primary sensor input. Check zone (room) sensor and wiring
75*	OUTDOOR TEMP SENSOR	<ul style="list-style-type: none"> If measurement of the outdoor temperature sensor is out of specified range (including open / short detection, the alarm will be activated. Alarm will automatically clear once in range condition is detected. Check sensor and wiring.
76*	HUMIDITY SENSOR	<ul style="list-style-type: none"> If measurement is below specified range (<5 % RH) the system will ignore the Relative Humidity readings. If measurement is above the specified range(>100% RH) the system will limit the value to 100%. If measurement of Relative Humidity Sensor is below specified range while the dehumidification mode using RH sensor is enabled, the system will set an alarm. The system will clear the alarm if Relative Humidity sensor measurement is detected in specified operating range OR dehumidification mode using RH sensor is disabled. Check sensor and wiring.
77*	DISCHARGE AIR TEMP SENSOR	<ul style="list-style-type: none"> If measurement of the discharge air temperature sensor is out of specified range (including open / short detection, the alarm will be activated. Alarm will automatically clear once in range condition is detected. Check sensor and wiring.
78*	RETURN AIR TEMP SENSOR	<ul style="list-style-type: none"> If measurement of the return air temperature sensor is out of specified range (including open / short detection, the alarm will be activated. Alarm will automatically clear once in range condition is detected. Check sensor and wiring.
79*	ID ADD ON BOARD PROBLEM	Add-on board problem, reset CORE Unit Controller to clear. When the communication alarm 80 persists for more than 30 seconds even after several retries for establishing the communication this Alarm is logged. Alarm can only be cleared by CORE Unit Controller reset.
80	ID ADD ON BOARD PROBLEM	When the CORE Unit Controller is not able to communicate with any attached add-on boards (C3 and GP3) this alarm code is logged. The CORE Unit Controller will retry to establish the communication once every 5 second. Alarm is automatically cleared once communication is restored.
81	REHEAT SETUP ERROR	Check reheat settings. Alarm 81 is raised under these two conditions: 1. If the user sets up the unit to use supermarket reheat on a non-gas unit. 2. If the user sets up the unit to use Humiditrol reheat but the heater type is heat pump
82	CONTROLLER RESET	If set when CORE Unit Controller powers up. Will Indicated reason for reset if known.
83*	INCORRECT SETTINGS	<ul style="list-style-type: none"> Check system configuration (model number, Configuration ID 1 and ID 2. If a model number is used that requires a daughter card, the CORE Unit Controller will attempt to detect the presences of the add-on board if not detected, this alarm will be set. This hardware configuration alarm can be only cleared by resetting or power cycling the CORE Unit Controller.
84	ADD ON BOARD NOT RESPONDING	An add-on board did not respond or is not recognized when polled by main control during system power-up. Add-on board with problem will have flickering heartbeat or no heartbeat.
85	INCORRECT HUMIDITROL	Check Humiditrol settings. Check Configuration ID 1, position 1 and verify that the position is not set to U. Should be set to either N (not installed) or H (Humiditrol). Alarm will automatically clear once correct option is set.

Table 11. CORE Control System Alarm and Event Codes

SELECTED ALARMS (MARKED WITH * IN TABLE RESULT IN THE CLOSURE OF THE SERVICE RELAY CONTACTS (DO1).		
ALARM CODE	DISPLAY MESSAGE	EVENT ACTION
86*	CONFLICTING TSTAT INPUT	Check thermostat inputs for simultaneous heat and cooling wiring. Once condition is corrected, unit controller will resume operation after error time off day has expired.
87	UNIT DIP SWITCH CHANGED	UNIT (equipment type) DIP switch has changed while unit is energized. Check UNIT DIP switch setting and reset control. Make sure the UNIT DIP switch settings agree with the unit type.
88	ECTO CHIP PROBLEM	This may indicate a problem with the ECTO chip.
89	UNIT ADDRESS NOT VALID	No address is set on unit address DIP switch SW3. Any one switch on SW3 must be in ON position. SW3 is factory set with switch #2 in on position.
90	RAM ERROR	RAM error.
91*	OUTDOOR ENTHALPY SENSOR	<ul style="list-style-type: none"> If Enthalpy Sensor failure is detected, the system will disable 'Free Cooling' operation. <p>NOTE: Valid Outdoor Enthalpy Sensor reading is required for both 'ODE' (Outdoor Enthalpy) and 'ODE differential' (Outdoor differential). Valid Indoor Enthalpy Sensor reading is required for 'ODE differential' (Outdoor differential).</p> <ul style="list-style-type: none"> Check economizer Parameters 160 and 161. Also check enthalpy Parameters 162 and 163. Check sensor and wiring.
92*	INDOOR ENTHALPY SENSOR	<p>If Enthalpy Sensor failure is detected, the system will disable 'Free Cooling' operation.</p> <p>NOTE: Valid Outdoor Enthalpy Sensor reading is required for both 'ODE' (Outdoor Enthalpy) and 'ODE differential' (Outdoor differential). Valid Indoor Enthalpy Sensor reading is required for 'ODE differential' (Outdoor differential).</p> <p>Check wiring and test A62 sensor using specified method in M3 application guide, section titled economizer checkout.</p>
93*	BACKUP MODE	<ul style="list-style-type: none"> Check communication loss with network sensor or if CORE Unit Controller If NETWORK INTEGRATION is set to RTU STANDALONE MODE and backup sensor is set to RETURN AIR BACKUP. While running in backup mode the unit controller will set this alarm. The unit controller will return from Backup mode to Primary (Main) mode on a reset or after the Primary mode (room Sensor is not in error or OR network communication is re-established and available for 300 seconds. Backup mode alarm will be cleared on the reset OR after the unit controller has returned to primary (main) system mode.
94*	BAD ZONE SENSOR SETPOINTS	Ensure that the heating and cooling set points honor the auto-changeover deadband.
95	ECTO PARAMETER CHANGED	ECTO parameter has been changed by the CORE Service application,
96	FOUR-STAGE INTERFACE FAILURE	Four stage interface failure A138. ECTO 6.01 set to option 12 when no A138 board present can also cause this alarm.
97	FOUR-STAGE CONFIGURATION ERROR	Four stage interface A138 detected but ECTO 6.01 is not set to option 12 or equipment type is set to heat pump.
98	ECTO MEMORY CHIP WRITE ERROR	ECTO memory chip write error.
99*	OAC ERROR	Check sensor and wiring. This alarm activates when the A24 sensor input signal is continuously above 25% of sensor measuring range for more than five minutes with blower stopped. The CORE Unit Controller will disable the Outdoor Air CFM control. The alarm automatically clears when the sensor reading is below 10% sensor measuring range for one minute.
100*	AIR VOL CONTROL SETUP ERROR	Check for proper installation of GP board and settings.
101*	MGV CONTROL SETUP ERROR	Check for proper installation of GP board and settings.
102*	GP CONTROL SETUP ERROR	Check for proper installation of GP board and settings.
103*	ADV CTRL SETUP ERROR	Check CORE Unit Controller Configuration ID 1 settings.
104	RESERVED	
105	ECONOMIZER CONFIGURATION ERROR	Economizer configuration error.
106*	BUILDING PRESS SENSOR	Check sensor and wiring.

Table 11. CORE Control System Alarm and Event Codes

SELECTED ALARMS (MARKED WITH * IN TABLE RESULT IN THE CLOSURE OF THE SERVICE RELAY CONTACTS (DO1).		
ALARM CODE	DISPLAY MESSAGE	EVENT ACTION
107*	DUCT SUPPLY PRESS SENSOR	<p>Check sensor and wiring.</p> <p>The unit controller will set Supply Air Static Pressure Sensor (A30) error status if:</p> <ul style="list-style-type: none"> Input signal is above 4.9" wc for more than 30 seconds. <p>OR</p> <ul style="list-style-type: none"> Input signal is below 0.1"wc 20 seconds after the blower has started with setting at or above Blower Output Static Duct Alarm Check. <p>The CORE Unit Controller will clear the Supply Air Static Pressure Sensor (A30) error status and alarm after the expiration of Error Time OFF delay.</p>
108	DUCT SUPPLY HIGH PRESS SENSOR	<ul style="list-style-type: none"> Check sensor and wiring. The CORE Unit Controller will shutdown operation for Error Off time (Parameter 110) if supply air static pressure exceeds supply static shutdown setpoint for 20 seconds (default) Parameter 42. The CORE Unit Controller will clear High Supply Static (Duct) Pressure after Error Off Time has expired and static duct pressure is below Supply Static Set Point Shutdown.
109*	STRIKE3 DUCT SUPPLY PRESS SENSOR	<ul style="list-style-type: none"> Check sensor and wiring. Unit controller shall "lockout" a unit operation after the Max Static Duct Pressure Occurrences have occurred of Supply Static Pressure Sensor Error (alarm 107) and/ or High Supply Static (Duct) Pressure (alarm 108). User shall be able to clear supply static pressure lockout and alarm via User Interface. Supply Static Pressure lockout and alarm shall be cleared after the unit controller reset. The number of strikes is three by default. this can be changed using Parameter 43. Optional occurrence setting is 1 to 7.
110	WAITING SENSOR DATA	Check network or comfort sensor and wiring.
111	PROFILE ERROR	Configuration profile unrecoverable. Settings may have changed.
112	INTERNAL EEPROM ERASE ERROR	Internal EEPROM erase error.
113	INTERNAL EEPROM WRITE ERROR	Internal EEPROM write error.
114	INTERNAL PLL CLOCK ERROR	Internal PLL clock error.
115	TEST MODE	UNIT TEST switch in test mode.
116	TEST MODE AT RESET	UNIT TEST switch in test mode at reset.
117	HIBERNATION MODE	To insure correct voltage phasing before startup, use refrigerant pressure gauges to check proper compressor operation and arrow label for blower rotation.
118	NO DISPLAY	Display is not connected or communication lost
119	RESERVED	
120	MCB CONFIGURATION ERROR	MCB configuration error. Cases that can cause this alarm:1- MCB not present, but ECTO 0.01 requires it. 2-MCB present, but ECTO 0.01 is not set for it
121*	ID LINE FREQ MISMATCH	Power source line frequency is determined by the entered model number. This alarm is enabled by the PhaseVoltage Detection feature. The CORE Unit Controller does not have an automatic clearing method, unit power cycle or reset will be required to re-evaluate the phase sequence again.
122*	24VAC PRIMARY VOLTAGE LOW	<ul style="list-style-type: none"> Low output voltage on T1 transformer. Alarm set when 24VAC voltage low if calculated RMS voltage is below low voltage alarm threshold for more than two seconds. System will stop unit operations (cooling, heating and ventilation). Low voltage threshold is 18VAC. The CORE Unit Controller will clear alarm 24VAC Voltage Low if calculated RMS voltage is above Low Voltage Alarm Threshold + 1 VAC for more than two seconds. After the low 24VAC alarm has been cleared, the CORE Unit Controller will ignore all service demands until the Error Time Off Delay has expired.
123*	24VAC PRIMARY VOLTAGE HIGH	<ul style="list-style-type: none"> High output voltage on T1 transformer. Alarm set when 24VAC voltage high if calculated RMS voltage is below low voltage alarm threshold for more than two seconds. System will stop unit operations (cooling, heating and ventilation). Low voltage threshold is 30VAC. The CORE Unit Controller will clear alarm 24VAC Voltage high if calculated RMS voltage is above High Voltage Alarm Threshold + 1 VAC for more than two seconds. After the HIGH 24VAC alarm has been cleared, the CORE Unit Controller will ignore all service demands until the Error Time Off Delay has expired.

Table 11. CORE Control System Alarm and Event Codes

SELECTED ALARMS (MARKED WITH * IN TABLE RESULT IN THE CLOSURE OF THE SERVICE RELAY CONTACTS (DO1).		
ALARM CODE	DISPLAY MESSAGE	EVENT ACTION
124*	24VAC SECONDARY VOLTAGE LOW	<ul style="list-style-type: none"> Low output voltage on T1 transformer. alarm set when 24VAC voltage low if calculated RMS voltage is below low voltage alarm threshold for more than two seconds. System will stop unit operations (cooling, heating and ventilation). Low voltage threshold is 18VAC. The CORE Unit Controller will clear alarm 24VAC Voltage Low if calculated RMS voltage is above Low Voltage Alarm Threshold + 1 VAC for more than two seconds. After the low 24VAC alarm has been cleared, the CORE Unit Controller will ignore all service demands until the Error Time Off Delay has expired.
125*	24VAC SECONDARY VOLTAGE HIGH	<ul style="list-style-type: none"> High output voltage on T1 transformer. alarm set when 24VAC voltage high if calculated RMS voltage is below low voltage alarm threshold for more than two seconds. System will stop unit operations (cooling, heating and ventilation). Low voltage threshold is 30VAC. The CORE Unit Controller will clear alarm 24VAC Voltage HIGH if calculated RMS voltage is above high voltage alarm Threshold + 1 VAC for more than two seconds. After the high 24VAC alarm has been cleared the CORE Unit Controller will ignore all service demands until the Error Time Off Delay has expired.
126*	LINE PHASING MISMATCH	During power up or reset of unit, Mismatch on single or 3 phase power, or reverse rotation on 3 phase detected. This alarm is enabled by the Phase Voltage Detection feature.
127	ALARM BUFFER OVERFLOW	Alarm buffer overflow.
128	24VAC SECONDARY POWER LOSS	Check transformer and wire connections.
129*	VFD SHUTDOWN	VFD fault detected. Check belt and for blower overload. Fix source of fault and reset CORE Unit Controller.
130	VFD BYPASS ENGAGED	VFD bypass mode. Mode is engaged. Blower may or may not be disengage.
131 RESERVED		
132	VFD BYPASS UNCONFIG	VFD bypass mode has not been selected. Unit operates as if bypass is not installed.
133 RESERVED		
134	LOW SUPPLY AIRFLOW	Advanced Airflow enabled RTU indicates airflow target cannot be achieved. Check cause of airflow reduction such as dirty filter, changes in duct work, etc
135*	NO SUPPLY AIRFLOW	Blower RPM is too low as indicates by blower status. This means that the blower is not working. Repair blower and reset CORE Unit Controller.
136*	OA DAMPER MECH FAULT	Outdoor air damper stuck or actuator problem.
137	LOW OUTDOOR AIRFLOW	Outdoor airflow is too low so the building is not getting the designed outdoor airflow based on IAQ.
138 RESERVED		
139	HIGH OUTDOOR AIRFLOW	Ventilation CFM is too high therefore the RTU is using excessive energy.
140	CFM TARGET TOO LOW	Verify the MSAV blower settings and set the CM targets below set CFM. The alarm value will be displayed on the CORE Unit Controller screen.
141	CFM TARGET TOO HIGH	
142 RESERVED		
143*	OA DAMPER ERROR	Outdoor air differential pressure sensor value not in valid range. Might be tubing problem or high return duct resistance.
144	FIRMWARE UPDATE COMPLETED	System updated with new firmware.
145	RESERVED	
146	SERVICE EVENT	Service event logged.
147*	DAMPER FDBK LOSS	During free cooling damper is not modulating.
148*	EP CONFIG ERROR	Economizer should be installed and blower should be ECM type.
149*	OA DIFF PRESS SENSOR ERROR	Check outdoor air damper differential pressure sensor and wiring.
150*	NOT ECONOMIZING WHEN OAS	May be due to the damper motor being unplugged or disconnected.
151*	ECONOMIZING WHEN OANS	This may be due to damper motor being blocked or stuck open and therefore not closing.
152 - 162 RESERVED		
163	LIQUID PRESS OPEN	
164	STRIKE3 LIQUID PRESS OPEN	
165	ECN UNCONFIGURED	Configuration ID 1, position 2 is set to U. Select applicable option using setup/install wizard.

Table 11. CORE Control System Alarm and Event Codes

SELECTED ALARMS (MARKED WITH * IN TABLE RESULT IN THE CLOSURE OF THE SERVICE RELAY CONTACTS (DO1).		
ALARM CODE	DISPLAY MESSAGE	EVENT ACTION
166	GAS CAB PRESSURE SW CLOSED GV1	This alarm will occur when the combustion air pressure switch (S18) is detected as closed immediately after the furnace demand relay is energized and before the combustion air blower is energized. Gas valve 1.
167	GAS CAB PRESSURE SW CLOSED GV2	This alarm will occur when the combustion air pressure switch (S45) is detected as closed immediately after the furnace demand relay is energized and before the combustion air blower is energized. Gas valve 2.
168*	COMBUSTION AIR SW NOT OPEN LOCKOUT GV1	System locked out due to S45 switch closed and a specific number occurrences detected based on Parameter 72 (max cai no prf occ) setting during a single cycle.
169*	COMBUSTION AIR SW NOT OPEN LOCKOUT GV2	
170	PWR EXH UNCONFIGURED	Configuration ID 1, position 3 is set as U (unconfigured).
171	PWR EXH CONFIG ERROR	Configuration ID 1, position 4 is set correctly. if position 3 is configured then position 4 must be also.
172	EP UNCONFIGURED	Economizer should be installed and blower should be ECM type.
173	AIR FLOW SW CONFIG ERR	Verify that Configuration ID 2, position 1 is set correctly.
174	BYPAS DAMPER CONFIG ERR	Room bypass damper operation is only compatible with cab blowers. Unit Controller will only allow zone bypass unit operation if configuration ID1 is set to installed for units with B or T type blowers. Alarm will automatically clear when configuration conflict is corrected.
175	NO INPUT SHARING	Alarm will occur if load shedding input is shared with other optional devices or inputs, for example - global, blower overload, drain pan overflow, etc.
176	SBUS OBSOLETE M2 CMD	This alarm occurs when a SBUS master device sends a M2 style command to the CORE Unit Controller. The alarm is immediately cleared and a history of the event is stored.
177	NO MODEL NUMBER	Missing model configuration data. Run setup > install and complete model number information.
178	LOW SUMP SUPERHEAT	
179	STRIKE3 LOW SUMP SUPERHEAT	
180	DEFECTIVE CRANKCASE HEATER1	
181	DEFECTIVE CRANKCASE HEATER2	
182	SUCTION PRESSURE SENSOR	
183	COMP1 SUMP TEMP SENSOR	<ul style="list-style-type: none"> Alarm will occur when an open or short condition is detected. Alarm will also occur when unit controller via the temperature sensor detects an out of range. Valid range is 30°F to 150°F. Possible causes are faulty temperature sensor / circuit or improper installati The alarming value indicates which Compressor Sump Temp sensor failed. <p>NOTE: Not supported in Model L.</p> <p>0 - Tandem 1 Compressor 2 Sump Temp Sensor Failure 1 - Tandem 2 Compressor 2 Sump Temp Sensor Failure</p> <p>NOTE: Not supported in Model L.</p>
184	COMP2 SUMP TEMP SENSOR	
185	ULTRA	Generic alarm for ultra issues. The alarming value will have different values for different issues.
186*	BLOWER MOTOR FAULT	In systems with EBM blower, prodigy shall start monitoring the motor alarm output (normally closed relay contact) ten seconds after blower command is sent. The CORE Unit Controller will stop unit operation if fault conditions (relay contact open logic input high) are detected. NOTE: Motor alarm is wired to P2597; shared with VFD alarm and ECM blower rpm inputs. Alarm will clear when inrange temperature is detected.
187	INVERTER MINOR	<ul style="list-style-type: none"> Alarming Value = Inverter error code Possible alarming values for Prodigy Alarm 187 are: <ul style="list-style-type: none"> > 12 - High Comp Current > 13 - High Heat sink temperature > 14 - High PFC input current If the alarm continues after outdoor conditions have moderated, check the fan, charge and coil. Alarm 187 will automatically clear when minimum off time expires. Refer to trouble shooting guide in service manual for more information.
NOTE: The inverter will automatically slow the compressor speed due to any of the above conditions and the condition drops below the time-based dependence of the system's output on present and past inputs.		

Table 11. CORE Control System Alarm and Event Codes

SELECTED ALARMS (MARKED WITH * IN TABLE RESULT IN THE CLOSURE OF THE SERVICE RELAY CONTACTS (DO1).		
ALARM CODE	DISPLAY MESSAGE	EVENT ACTION
188	INVERTER MAJOR	<ul style="list-style-type: none"> • Alarming Value = Inverter error code • Possible alarming values for unit controller alarm 188 are: <ul style="list-style-type: none"> > 21 - Peak DC current > 22 - Maximum current reached lockout > 23 - DC Link low voltage > 26 - Locked Rotor > 28 - DC Link high voltage > 29 - Compressor over current > 61 - Low outdoor ambient inverter lockout > 62 - High Heat Sink Temperature lockout > 75 - Low Input Voltage • No action required. Compressor stops for the duration of the minimum run time. Unit shuts down after ten occurrences in one hour and Alarm 189 is initiated. Alarm 188 will automatically clear when inverter error clears. • Refer to trouble shooting guide in service manual for more information.
189	INVERTER FATAL	<ul style="list-style-type: none"> • Alarming Value = Inverter error code • Possible alarming values for alarm 189 are 21, 22, 23, 26, 28, 29, 61, 62 and 75. • Alarm 189 will clear upon manual reset. • Refer to trouble shooting guide in service manual for more information.
190	INVERTER COMM	Unable to communicate with inverter. The unit controller will disable compressor operation. Replace communication cable between inverter and CORE Unit Controller. If alarm continues, replace CORE Unit Controller or inverter.
191	INVERTER VOLTAGE MISMATCH	The unit controller will disable compressor operation. Replace with correct inverter part.
192	HIGH TEMP S7 OPEN COMP1	Check temperature trip switch. Compressor is off. Also check charge, fans and coil. The unit controller will clear the temperature trip alarm when corresponding compressor top cap temperature trip switch is detected as closed. Compressor will not restart until the corresponding temperature trip switch is closed and the minimum off delay has expired.
193	STRIKE3 HIGH TEMP S7 OPEN COMP1	The unit controller will disable compressor operation (lockout). Check switch, charge, fans and coil. Default is three occurrences. Alarm will be automatically cleared after removal of cooling demand.
194	CRITICAL LOSS CONDENSER AIRFLOW	Critical Loss of Condenser Airflow
195	C1 CRITICAL LOSS OF CHARGE	Critical Loss of Charge Compressor 1. In Model L this is determined by temperature readings from sensors on the coils.
196	C2 CRITICAL LOSS OF CHARGE	Critical Loss of Charge Compressor 2. In Model L this is determined by temperature readings from sensors on the coils.
197	C3 CRITICAL LOSS OF CHARGE	Critical Loss of Charge Compressor 3. In Model L this is determined by temperature readings from sensors on the coils.
198	C4 CRITICAL LOSS OF CHARGE	Critical Loss of Charge Compressor 4. In Model L this is determined by temperature readings from sensors on the coils.
199	CRITICAL LOSS OF EVAPORATOR AIRFLOW	Critical Loss of Evaporator Airflow
200	C1 NON OPERATING COMPRESSOR	Compressor 1 Not Operating
201	C2 NON OPERATING COMPRESSOR	Compressor 2 Not Operating
202	C3 NON OPERATING COMPRESSOR	Compressor 3 Not Operating
203	C4 NON OPERATING COMPRESSOR	Compressor 4 Not Operating
204	C1 TXV FAILED CLOSED	Compressor 1 TXV Failed Closed
205	C2 TXV FAILED CLOSED	Compressor 2 TXV Failed Closed
206	C3 TXV FAILED CLOSED	Compressor 3 TXV Failed Closed
207	C4 TXV FAILED CLOSED	Compressor 4 TXV Failed Closed
208	C1 MAJOR LOSS CHARGE	Major Loss of Charge Compressor 1
209	C2 MAJOR LOSS CHARGE	Major Loss of Charge Compressor 2
210	C3 MAJOR LOSS CHARGE	Major Loss of Charge Compressor 3
211	C4 MAJOR LOSS CHARGE	Major Loss of Charge Compressor 4

Table 11. CORE Control System Alarm and Event Codes

SELECTED ALARMS (MARKED WITH * IN TABLE RESULT IN THE CLOSURE OF THE SERVICE RELAY CONTACTS (DO1).		
ALARM CODE	DISPLAY MESSAGE	EVENT ACTION
212	MAJOR LOSS CONDENSER AIRFLOW	Major Loss of Condenser Airflow
213	MAJOR LOSS EVAPORATOR AIRFLOW	Major Loss of Evaporator Airflow
214	C1 COMPRESSOR FLOODING	Compressor Flooding Compressor 1
215	C2 COMPRESSOR FLOODING	Compressor Flooding Compressor 2
216	C3 COMPRESSOR FLOODING	Compressor Flooding Compressor 3
217	C4 COMPRESSOR FLOODING	Compressor Flooding Compressor 4
218	C1 SAT LIQUID TEMP SENSOR	Saturated Liquid Temperature Sensor Circuit 1 has failed. Saturated Liquid Temperature Sensor Circuit 1 has become dislodged.
219	C2 SAT LIQUID TEMP SENSOR	Saturated Liquid Temperature Sensor Circuit 2 has failed. Saturated Liquid Temperature Sensor Circuit 2 has become dislodged.
220	C3 SAT LIQUID TEMP SENSOR	Saturated Liquid Temperature Sensor Circuit 3 has failed. Saturated Liquid Temperature Sensor Circuit 3 has become dislodged.
221	C4 SAT LIQUID TEMP SENSOR	Saturated Liquid Temperature Sensor Circuit 4 has failed. Saturated Liquid Temperature Sensor Circuit 4 has become dislodged.
222	C1 LIQUID TEMP SENSOR	Liquid Temperature Sensor Circuit 1 has failed. Liquid Temperature Sensor Circuit 1 has become dislodged.
223	C2 LIQUID TEMP SENSOR	Liquid Temperature Sensor Circuit 2 has failed. Liquid Temperature Sensor Circuit 2 has become dislodged.
224	C3 LIQUID TEMP SENSOR	Liquid Temperature Sensor Circuit 3 has failed. Liquid Temperature Sensor Circuit 3 has become dislodged.
225	C4 LIQUID TEMP SENSOR	Liquid Temperature Sensor Circuit 4 has failed. Liquid Temperature Sensor Circuit 4 has become dislodged.
226	C1 SAT SUCTION TEMP SENSOR	Saturated Suction Temperature Sensor Circuit 1 has failed. Saturated Suction Temperature Sensor Circuit 1 has become dislodged.
227	C2 SAT SUCTION TEMP SENSOR	Saturated Suction Temperature Sensor Circuit 2 has failed. Saturated Suction Temperature Sensor Circuit 2 has become dislodged.
228	C3 SAT SUCTION TEMP SENSOR	Saturated Suction Temperature Sensor Circuit 3 has failed. Saturated Suction Temperature Sensor Circuit 3 has become dislodged.
229	C4 SAT SUCTION TEMP SENSOR	Saturated Suction Temperature Sensor Circuit 4 has failed. Saturated Suction Temperature Sensor Circuit 4 has become dislodged.
230	C1 SUCTION TEMP SENSOR	Suction Temperature Sensor Circuit 1 has failed. Suction Temperature Sensor Circuit 1 has become dislodged.
231	C2 SUCTION TEMP SENSOR	Suction Temperature Sensor Circuit 2 has failed. Suction Temperature Sensor Circuit 2 has become dislodged.
232	C3 SUCTION TEMP SENSOR	Suction Temperature Sensor Circuit 3 has failed. Suction Temperature Sensor Circuit 3 has become dislodged.
233	C4 SUCTION TEMP SENSOR	Suction Temperature Sensor Circuit 4 has failed. Suction Temperature Sensor Circuit 4 has become dislodged.
234	UTEC INTERNAL FAULT GV1 ROM RAM	
235	UTEC INTERNAL FAULT GV2 ROM RAM	
236	UTEC MAX FLAME LOSS GV1	
237	UTEC MAX FLAME LOSS GV2	
238	UTEC FALSE FLAME GV1	
239	UTEC FALSE FLAME GV2	
240	UTEC INTERNAL FAULT GV1 VALVE	
241	UTEC INTERNAL FAULT GV2 VALVE	
242	UTEC VALVE FAULT LOCKOUT GV1	

Table 11. CORE Control System Alarm and Event Codes

SELECTED ALARMS (MARKED WITH * IN TABLE RESULT IN THE CLOSURE OF THE SERVICE RELAY CONTACTS (DO1).		
ALARM CODE	DISPLAY MESSAGE	EVENT ACTION
243	UTEC VALVE FAULT LOCKOUT GV2	
244 - 255	RESERVED	
500	Error Reading USB Device	Error Reading USB Device
501	USB Device not Mounted	USB Device not Mounted
502	USB Device Full	USB Device Full
503	Invalid DIN number	Invalid DIN number received from M4. Indicates DIN incompatibility

15. CORE Control System Unit Parameters

Table 12. CORE Control System Unit Parameters							
Control Parameter No	Screen Name	Parameter Short Description	Control Value			Units	Description
			Min.	Default	Max.		
2	LANGUAGE	LANGUAGE		ENGLISH, SPANISH OR FRENCH		Option	Select desired language for user interface. Options are English, French and Spanish.
Power and Damper Parameters							
5	VAV CONTROL MODE	Variable Air Volume Control Mode	0	If applicable to specific unit,	511	Option	Applicable to Standard Efficiency 3- to 6-ton units only. <ul style="list-style-type: none"> 16 = Runs the blower in high speed when occupied and there is not other active demand (room sensor mode only) 32 = Runs the blower in high speed when G is active and there is no other active demand (thermostat mode only)
6	BLOWER SMOKE OUTPUT	Blower Smoke Output	20	Depends on equipment	100	%	<ul style="list-style-type: none"> Applicable to High Efficiency 3- to 5-ton units. Blower staged percentage output during smoke detection.
7	BLOWER HEAT OUTPUT	Blower Heat Output	20	Depends on equipment	100	%	<ul style="list-style-type: none"> Applicable to High Efficiency 3- to 5-ton units only. Blower staged percentage output high speed; used for high heating speed.
8	BLOWER LO CL OUTPUT	Blower Cool Output	20	Depends on equipment	100	%	<ul style="list-style-type: none"> Applicable to High Efficiency 3- to 5-ton units only. Blower staged percentage output low speed; used for low cooling or ventilation.
9	MIN DAMPER LOW BLWR	Minimum Damper Position During High Speed Blower Operation	0	0	100	%	<ul style="list-style-type: none"> Minimum damper position during low speed blower operation. Use Parameter 132 during high speed blower operation
10	FREE CL STG UP DLY	Free Cooling Blower Stage Up Delay	0	300	1800	Sec	<ul style="list-style-type: none"> Applicable to Standard Efficiency 3- to 6-ton only. Free cooling blower stage-up delay. Blower runs low speed during delay, and then shifts to high speed.
11	ENBL FIELD STAT RPT	Enabled Field Status Report		0 = OFF 1 = ON		Option	Enabled Field Status Report
12	MSAV SMK CFM	Multi-Stage Air Volume Smoke Detection Mode (Alarm)	450	Default may be altered at factory test.	14400	CFM	Multi-Stage Air Volume Smoke Detection Mode (Alarm) NOTE: In order for the SMOKE CFM change to take affect, go the SETUP > TEST & BALANCE > BLOWER and run the wizard. Performing this task will recalculate the output to the desired CFM. No adjustments are required during this procedure.
19	MAX CFM RPM	Maximum Cubic Feet Per Minute Revolutions Per Minute	445	Default may be altered at factory test.	1780	RPM	Maximum Cubic Feet Per Minute Revolutions Per Minute
27	MIN OUPT CL VT SMK	Minimum Output Cooling Vent Smoke Detection Mode (Alarm)	30	50	100	%	Minimum Output Cooling Vent Smoke Detection Mode (Alarm)
28	MIN OUTPUT HEAT	Minimum Output Heat	30	50	100	%	Minimum Output Heat
29	MIN DAMPER BLOWER	Minimum Damper Blower	0	Default may be altered at factory test.	101	%	Setting this Parameter to 101.0% will disable this feature.

Table 12. CORE Control System Unit Parameters

Control Parameter No	Screen Name	Parameter Short Description	Control Value			Units	Description
			Min.	Default	Max.		
30	PWREXH STG2 MIN BLR	Power Exhaust Stage 2 Minimum Blower	0	70	100	%	Power Exhaust Stage 2 Minimum Blower
31	SUPPLY PID P CONST	Supply Proportional Base Control Loop for Variable Air Volume or Constant Air Volume with Bypass Damper	0	17	127	Counts	Variable Air Volume or Constant Air Volume with Bypass Damper supply PID Proportional constant.
32	SUPPLY PID I CONST	Supply Integral Base Control Loop for Variable Air Volume or Constant Air Volume with Bypass Damper	0	12	127	Counts	Variable Air Volume or Constant Air Volume with Bypass Damper supply PID Integral constant.
33	SUPPLY PID D CONST	Supply Derivative Base Control Loop for Variable Air Volume or Constant Air Volume with Bypass Damper	0	0	127	Counts	Variable Air Volume or Constant Air Volume with Bypass Damper supply PID derivative constant.
34	BLR STC PRESS SMK SP	Constant Air Volume with Bypass Damper Static Pressure Set Point During Smoke Alarm	0	1	5	w.c.	Constant air volume with bypass damper static pressure set point during smoke alarm.
35	BLR STC PRES VT SP	Constant Air Volume with Bypass Damper Static Pressure Set Point for Ventilation	0	1	5	w.c.	Constant air volume with bypass damper static pressure set point for ventilation.
36	BLR STC PRES HT SP	Constant Air Volume with Bypass Damper Static Pressure Set Point for Heating	0	1	5	w.c.	Constant air volume with bypass damper static pressure set point for heating
37	BLR STC PRES CL SP	Constant Air Volume with Bypass Damper Static Pressure Set Point for Cooling	0	1	5	w.c.	Constant air volume with bypass damper static pressure set point for cooling
38	MIN OUTPT CL VT SMK	Constant Air Volume with Bypass Damper Minimum Output Percentage Set Point for Cooling, Ventilation and Smoke Alarms	20	20	100	%	<ul style="list-style-type: none"> Constant air volume with bypass damper minimum output for cooling, ventilation and during smoke alarms. This sets the minimum air delivered. Bypass damper motor is set to 10 to 2 volts with 10 volts being closed. 20% setting = 2 volts or damper completely opened.
39	MIN OUTPUT HEAT	Constant Air Volume with Bypass Damper Minimum Output Percentage Set Point for Heating	20	20	100	%	<ul style="list-style-type: none"> Constant air volume with bypass damper minimum output for heating. This sets the minimum air delivered. Bypass damper motor is set to 10 to 2 volts with 10 volts being closed. 20% setting = 2 volts or damper completely opened.

Table 12. CORE Control System Unit Parameters

Control Parameter No	Screen Name	Parameter Short Description	Control Value			Units	Description
			Min.	Default	Max.		
40	BLOWER MAX OUTPUT	Constant Air Volume with Bypass Damper Maximum Output Percentage Set Point	40	100	100	%	<ul style="list-style-type: none"> Constant air volume with bypass damper maximum output. This sets the maximum air delivered. Bypass damper motor is set to 10 to 2 volts with 10 volts being closed. 100% setting = 10 volts or damper completely closed.
41	SUPPLY MANUAL RESET	Constant Air Volume with Bypass Damper Manual Reset Value Output Percentage Set Point	20	52	100	%	Constant air volume with bypass damper manual reset value output. This is the output when unit is off.
42	STATIC SHUTDOWN SP	Air Supply Static Shutdown Set Point	0	2	5	w.c.	Supply static shutdown set point. Unit will shutdown for Parameter 110 minutes if duct pressure exceeds this value for 20 seconds.
43	STATIC LOCKOUT CNT	Static Pressure Lockout Counter Set Point	1	3	7	Counts	<ul style="list-style-type: none"> The number of occurrences before permanent lockout. Counter resets when unit controller resets. Refer to Parameter 226 to either enable or disable this feature.
44	STATIC LO ALARM CHK	Supply Static Sensor (A30) Low Alarm Percentage Set Point	30	40	100	%	<ul style="list-style-type: none"> Supply Static Pressure Sensor (A30) connected at (A133_P195_6) (TB18_6) alarm threshold. Blower percent speed before checking sensor after a 20 second delay. A value of 30% disables the low threshold or "open" alarm trap.
Electric Heating Parameters							
58	HT ELEC WARMUP DLAY	Electric Heat Warm-up Time Delay for Economizer	0	60	136	Minutes	Warm-up time delay. The time that the economizer is forced closed during warm-up (first occupied + heat demand)
60	HT ELEC BL OFF DLAY	Electric Heat Blower Off Delay Set Point.	0	System Dependent	300	Seconds	The time the blower stays on after the heating demand is satisfied.
61	HT ELEC MAX LT OCC	Electric Heat Maximum Primary and Secondary	1	3	15	Counts	Service output activation. Maximum Primary and Secondary Limit occurrences stored before service relay is energized. NOTE: Heating stage is not locked out.
62	HT ELEC STAGE DELAY	Electric Heat Time Delay Between Heat Stages	12	12	60	Seconds	Time delay between heat stages.
63	HT ELEC STG UP TMR	Electric Heat Maximum Lower Stage Run Time in Room Sensor Applications	0	912	3600	Seconds	<ul style="list-style-type: none"> Stage up timer. The maximum time that lower stage runs before calling next heat stage. Used in room sensor applications. Disabled if set to 0.
64	HT ELEC STG DWN TMR	Electric Heat Time Delay for Lower Stage Termination Following Higher Stage Termination	0	0	3600	Seconds	<ul style="list-style-type: none"> Time delay before a lower stage turns off following a higher stage termination. Used in room sensor applications.
Gas Heating Parameters							
65	HT GAS WARMUP DELAY	Gas Time Delay for Economizer Being Closed During Warm-up	0	60	136	Minutes	Warm-up time delay. The time that the economizer is forced closed during warm-up (first occupied + heat demand).

Table 12. CORE Control System Unit Parameters

Control Parameter No	Screen Name	Parameter Short Description	Control Value			Units	Description
			Min.	Default	Max.		
66	HT GAS BLR ON DELAY	Gas Blower On Delay After Heating Demand	8	System Dependent	60	Seconds	The time before the blower turns on after a heating demand.
67	HT GAS BLR OFF DLAY	Gas Blower Off Delay After Heading Demand Termination	80	System Dependent	300	Seconds	The time the blower stays on after the heating demand is terminated.
69	HT GAS HI FIRE DLAY	Gas Minimum Low Fire Time Prior to High Fire	30	100	300	Seconds	The minimum low fire time before high fire is allowed.
70	HT GAS OFF DELAY	Heating Off Delay Timer	30	100	300	Seconds	Heating off delay.
71	MAX CAI PRF SW OCC	Maximum Combustion Air Inducer Proof Switch Occurrence Setting Prior To Service Output Energized.	1	3	5	Occurrences	Service relay activation. Maximum combustion air Inducer proof switch occurrences stored before service output is energized.
72	MAX CAI NO PRF OCC	Maximum Combustion Air Inducer Proof Switch Occurrences	1	3	15	Occurrences	After the initial maximum combustion air Inducer proof switch closure, the system will continue to monitor the pressure switch and set alarm if three open occurrences are detected
73	MAX GV SENSE OCC	Maximum Gas Valve Sense Occurrences Stored Prior to Service Output Is Energized	1	3	5	Occurrences	Service output activation. Maximum gas valve sense occurrences stored before service output is energized. NOTE: Heating stage is not locked out.
74	HT GAS STG UP TMR	Gas Stage Up Timer	0	912	3600	Seconds	<ul style="list-style-type: none"> Stage-up timer. The maximum time that lower stage runs before calling next heat stage. Used in room sensor applications. Disabled if set to 0.
75	HT GAS STG DWN TMR	Gas Stage Down Timer	0	0	3600	Seconds	<ul style="list-style-type: none"> Time delay before a lower stage turns off following a higher stage termination. Used in room sensor applications.

Table 12. CORE Control System Unit Parameters

Control Parameter No	Screen Name	Parameter Short Description	Control Value			Units	Description
			Min.	Default	Max.		
Block 4 Cooling Parameters							
78	COOL DOWN DELAY	Cool Down Time Delay	0	30	136	Minutes	<ul style="list-style-type: none"> Cool down time delay. Time that Y2 is ignored during cool down period (when first occupied + cool demand) This delay is only used if an economizer is used and the outdoor air is suitable.
79	COOL BLR ON DELAY	Cooling Blower On Time Delay	0	See section 3.3.9. on page 20 for defaults.	60	Seconds	The time before the blower turns on after a cooling demand.
80	COOL BLR OFF DELAY	Cooling Blower Off Time Delay	0	See section 3.3.10. on page 20 for defaults.	240	Seconds	The time the blower stays on after the cooling demand is lost.
81	MAX FREEZE STAT OCC	Maximum Freeze Thermostat Occurrence	1	3	3	Occurrences	Service output activation and compressor lockout. Maximum freeze thermostat occurrences are stored before service relay is energized and compressor is locked-out.
82	COND FAN RESTRT DLY	Condenser Fan Restart Time Delay	0	6	16	Seconds	Low ambient anti-windmilling condenser fan delay. The time period that the last operating fan is turned off before starting the next fan.
83	LAC SP TEMP 1	Low Ambient Outdoor Air Limit Temperature 1 Set Point	10	40	60	°F	<ul style="list-style-type: none"> Low ambient outdoor air limit temp. 1. Parameters 83 and 84 are used to shed fans. Temperature setting must be less than or equal to Parameter 84.
84	LAC SP TEMP 2	Low Ambient Outdoor Air Limit Temperature 2 Set Point	10	55	60	°F	<ul style="list-style-type: none"> Low ambient outdoor air limit temp. 2. Parameters 83 and 84 are used to shed fans. Temperature setting must be greater than or equal to Parameter 83.
85	COMP1 LO TMP LCKOUT	Low Ambient Temperature Lockout for Compressor 1	-31	Default may be altered at factory test.	80	°F	<ul style="list-style-type: none"> Low ambient lockout for compressor 1. A value of (-31°F) will disable low ambient lockout function. Temperature setting must be less than or equal to Parameter 86.
86	COMP2 LO TMP LCKOUT	Low Ambient Temperature Lockout for Compressor 2	-31	Default may be altered at factory test.	80	°F	<ul style="list-style-type: none"> Low ambient lockout for compressor 2. A value of (-31°F) will disable low ambient lockout function. Temperature setting must be greater than or equal to Parameter 85 and less than or equal to Parameter 87.
87	COMP3 LO TMP LCKOUT	Low Ambient Temperature Lockout for Compressor 3	-31	Default may be altered at factory test.	80	°F	<ul style="list-style-type: none"> Low ambient lockout for compressor 3. A value of (-31°F) will disable low ambient lockout function. Temperature setting must be greater than or equal to Parameter 86 and less than or equal to Parameter 88.
88	COMP4 LO TMP LCKOUT	Low Ambient Temperature Lockout for Compressor 4	-31	Default may be altered at factory test.	80	°F	<ul style="list-style-type: none"> Low ambient lockout for compressor 4. A value of (-31°F) will disable low ambient lockout function. Temperature setting must be greater than or equal to Parameter 87.

Table 12. CORE Control System Unit Parameters

Control Parameter No	Screen Name	Parameter Short Description	Control Value			Units	Description
			Min.	Default	Max.		
89	COMP MIN OFF DELAY	Compressor Minimum Off Delay	60	300	510	Seconds	Compressor minimum off delay.
91	COMP MIN RUN TIME	Compressor Minimum Run Time	60	240	510	Seconds	Compressor minimum run time.
98	MAX HP OCCURRENCES	Maximum High Pressure Occurrences	1	3	7	Occurrences	Maximum High Pressure occurrences that are stored before control locks off compressor stage and energizes the service output.
99	MAX LP OCCURRENCES	Maximum Low Pressure Occurrences	1	3	7	Occurrences	Maximum Low Pressure occurrences that are stored before control locks off compressor stage and energizes the service relay.
100	LP SW IGNORE TIME	Low Pressure Switch Ignore Time	0	120	600	Seconds	Low Pressure Switch Ignore Time
101	CL STG 2 STGUP TIME	Maximum Stage 1 Cooling Time Before Call for Stage 2 Cooling	0	912	3600	Seconds	<ul style="list-style-type: none"> Stage 2 stage up timer. The maximum time that cooling stage 1 runs before calling cooling stage 2. Used in room sensor applications. Disabled if set to 0.
102	CL STG 3 STGUP TIME	Maximum Stage 2 Cooling Time Before Call for Stage 3 Cooling	0	912	3600	Seconds	<ul style="list-style-type: none"> Stage 3 stage up timer. The maximum time that cooling stage 2 runs before calling cooling stage 3. Used in room sensor applications. Disabled if set to 0.
103	CL STG 4 STGUP TIME	Maximum Stage 3 Cooling Time Before Call for Stage 4 Cooling	0	912	3600	Seconds	<ul style="list-style-type: none"> Stage 4 stage up timer. The maximum time that cooling stage 3 runs before calling cooling stage 4. Used in room sensor applications. Disabled if set to 0
104	CL STAGE DOWN TIME	Cooling Stage Down Time	0	912	3600	Seconds	<ul style="list-style-type: none"> Time delay before a lower stage turns off following a higher stage termination. Used in room sensor applications.
105	DEHUMID MODE	Dehumidification Mode	0	0 - No Humiditrol is installed 6 - All Others (Check Unit Parameter Label)	7	Option	Dehumidification Mode <ul style="list-style-type: none"> 0 = No reheat. 1 = Supermarket reheat using De-Humidistat (wired thermostat mode only) 2 = Supermarket reheat using relative humidity sensor. 3 = Humiditrol reheat. Conditions: Blower must be energized, Must be occupied, At least one previous cooling demand. 4 = Relative Humidity measurement / display. No Supermarket or Humiditrol reheat. 5 = Humiditrol reheat. Conditions: At least one previous cooling demand. 6 = Humiditrol reheat. Conditions: Blower must be energized, Must be occupied. 7 = Humiditrol reheat. Conditions: None

Table 12. CORE Control System Unit Parameters

Control Parameter No	Screen Name	Parameter Short Description	Control Value			Units	Description
			Min.	Default	Max.		
106	DEHUMID SETPOINT	Dehumidification Set Point	0	Default may be altered at factory test.	99	% RH	<ul style="list-style-type: none"> Percent relative humidity where supermarket or Humiditrol reheat demand is energized. Used of dehumid mode option 2, 3, 5, 6 or 7. Dehumidification is de-energized at set point – dead-band (Parameter 107)). Digital Input 4 only. Energized input signal calls for dehumidification demand. L Connection Network Relative Humidity set point will override this set point. (Such as from NCP).
107	DEHUMID DEADBAND	Dehumidification Dead Band (neutral zone)	1	3	10	% RH	<p>Used of dehumidification Parameter 105, option 2, 3, 5, 6 or 7. Dehumidification is:</p> <ul style="list-style-type: none"> ON when relative humidity is equal to or greater than Parameter 106. OFF when Relative Humidity is less than Parameter 106 minus Parameter 107.
108	FREE LO AMB LCKT SP	Free Cooling Low Ambient Lockout Set Point	45	55	80	°F	When outdoor air is suitable for free cooling and an economizer is present, the compressor will not run when ambient is below this value.
109	SMOKE ALARM CONTROL	Smoke Alarm Control	0	0	13	Option	<p>Smoke alarm control options.</p> <ul style="list-style-type: none"> 0 = Blower off, exhaust fan off and fresh air damper closed. 2 = Blower off, exhaust fan on and fresh air damper closed. 9 = Blower on, exhaust fan off and fresh air damper opened. 10 = Blower on, exhaust fan on and fresh air damper closed. 11 = Blower on, exhaust fan on and fresh air damper opened.
110	ERR TIME OFF DELAY	Error Time Off Delay	64	300	1800	Seconds	Off time delay if a “no-run” error occurs.
111	COOL STAGING OPTION	Cooling Staging Option	0	Default may be altered at factory test.	4	Option	<p>Cooling staging options:</p> <ul style="list-style-type: none"> 0 = No cooling operation 1 = Wired thermostat operation, Two cooling stages and units with Economizers <ul style="list-style-type: none"> > Y1 = Free Cooling, > Y2 = Adds all mechanical stages. 2 = Wired thermostat operation. Two cooling stages and Units with Economizers <ul style="list-style-type: none"> > Y1 - Free Cooling > Y2 - adds first stage of mechanical. 3 = Wired thermostat operation. Three cooling stages. <ul style="list-style-type: none"> > Y1 only - first stage, > Y2 only - second stage, > Y1+Y2 - third stage. <p>NOTE: Units with Economizers Y2 only adds first stage of mechanical, Y1+Y2 adds first and second stage of mechanical.</p> <ul style="list-style-type: none"> 4 = Discharge air control. Up to four stages.

Table 12. CORE Control System Unit Parameters

Control Parameter No	Screen Name	Parameter Short Description	Control Value			Units	Description
			Min.	Default	Max.		
Block 5 Miscellaneous Parameters							
112	HEAT STAGING OPTION	Heating Staging Option	0	2	2	Option	Heating staging options: <ul style="list-style-type: none"> • 0 = No heating operation. • 1 = Discharge air control with up to four stages. • 2 = Thermostat operation.
113	EN RET AIR TMP LMT	Enable Return Air Temperature Limit	0	0	1	Option	<ul style="list-style-type: none"> • Enables return air temperature limit option. • Return air limits may be used for limiting zone temperatures. Continuous fan operation recommended.
114	COOL RET AIR LIMIT	Cooling Return Air Limit	60	65	80	°F	<ul style="list-style-type: none"> • Return air limit for cooling. If the return air cooling limit is exceeded, the cooling demands are interrupted. • Parameter 113 must be set to 1 to enable.
115	HEAT RET AIR LIMIT	Heating Return Air Limit	60	85	100	°F	<ul style="list-style-type: none"> • Return air limit for heating. If the return air heating limit is exceeded, the heating demands are interrupted. • Parameter 113 must be set to 1 to enable.
117	DCV MAX DAMPER OPEN	Demand Control Ventilation Maximum Damper Open	0	50	100	%	Maximum allowed demand control ventilation damper open position.
118	DCV DAMP START OPEN	Demand Control Ventilation Damper Start Open	0	700	2000	PPM	<ul style="list-style-type: none"> • Damper "start open" CO₂ set point for Demand Control Ventilation. • Level where fresh air damper begins to open.
119	DCV DAMP FULL OPEN	Demand Control Ventilation Maximum Damper Full Open Set Point	0	1200	2000	PPM	<ul style="list-style-type: none"> • Damper "full open" CO₂ set point for Demand Control Ventilation. • Level where fresh air damper is opened to maximum.
120	DCV HI TMP OV FL CL	Demand Control Ventilation Outdoor Air Control Hi Temperature Override Full Closed	-31	105	132	°F	High outdoor air temp. where fresh air damper is closed to minimum position.
121	DCV HI TMP OV ST CL	Demand Control Ventilation Outdoor Air Control Hi Temperature Override Start Closing	-31	75	132	°F	High outdoor air temperature where fresh air damper begins to close.
122	DCV LO TMP OV FL CL	Demand Control Ventilation Outdoor Air Control Low Temperature Override Full Closed	-31	10	132	°F	Low outdoor air temperature where fresh air damper is closed to minimum position
123	DCV LO TMP OV ST CL	Demand Control Ventilation Outdoor Air Control Low Temperature Override Start Closing	-31	40	132	°F	Low outdoor air temp. where fresh air damper begins to close.

Table 12. CORE Control System Unit Parameters

Control Parameter No	Screen Name	Parameter Short Description	Control Value			Units	Description
			Min.	Default	Max.		
127	OAC MANUAL RESET	Outdoor Air Control Manual Reset	0	50	100	%	Manual reset value.
128	OAC PID P CONSTANT	Outdoor Air Control PID P Constant	0	2	127	Counts	Outdoor Air Control PID P Constant
129	OAC PID I CONSTANT	Outdoor Air Control PID I Constant	0	30	127	Counts	Outdoor Air Control PID I Constant
130	OAC PID D CONSTANT	Outdoor Air Control PID D Constant	0	0	127	Counts	Outdoor Air Control PID D Constant
131	FREE CL MAX DAMPER	Free Cooling Maximum Damper	0	100	100	%	The maximum allowed fresh air damper opening for free cooling.
132	MIN DAMPER POSITION	Minimum Damper Position	0	0	100	%	Minimum fresh air damper position during occupied operation.
133	ZONE SENS STRTUP DLY	Room Sensor Start-up Delay	2	2	30	Minutes	<ul style="list-style-type: none"> Suspends all unit operation room sensor and Constant Air Volume with bypass damper applications. Suspends Fresh Air Heat Control-Reheat, Fresh Air Cooling Control, Fresh Air Heat Control options and all GP outputs. May be used to stagger unit start-ups. Does NOT delay demands in thermostat mode.
134	IAQ INPUT MODE	Indoor Air Quality Input Mode	0	1	7	Option	Options are: <ul style="list-style-type: none"> 0 = Ventilation is disabled. 1 = Demand control ventilation with outdoor temperature limit and blower on. (Default) 2 = Demand control ventilation without Outdoor Temperature Limit and Blower ON. 3 = Demand control ventilation with Outdoor Temperature Limit and Blower AUTO / ON. 4 = Demand control ventilation without Outdoor temperature Limit and no blower AUTO / ON. 5 = Outdoor air control with outdoor temperature limit. 6 = Outdoor air control without outdoor temperature limit 7 = Building pressure control
System 1 Parameters							
137	OCC HEAT STPT	Occupied Heating Set Point	40	Default may be altered at factory test.	95	°F	<ul style="list-style-type: none"> Backup occupied heating set point. Used if the communications link is lost for 5 minutes between the M3 and NCP. Used only with room sensor applications. Set point temperature must be less than or equal to (Parameter 139 minus Parameter 152).

Table 12. CORE Control System Unit Parameters

Control Parameter No	Screen Name	Parameter Short Description	Control Value			Units	Description
			Min.	Default	Max.		
138	UNOCC HEAT STPT	Unoccupied Heating Set Point	40	60	95	°F	<ul style="list-style-type: none"> Backup unoccupied heating set point. Used if the communications link is lost for 5 minutes between the unit controller and NCP. Used only in room sensor applications. Set point temperature must be less than or equal to (Parameter 140 minus Parameter 152).
139	OCC COOL STPT	Occupied Cooling Set Point	40	75	95	°F	<ul style="list-style-type: none"> Backup occupied cooling set point. Used if the communications link is lost for 5 minutes between the unit controller and NCP. Used only in room sensor applications. Set point temperature must be greater than or equal to Parameter 137 plus Parameter 152).
140	UNOCC COOL STPT	Unoccupied Cooling Set Point	40	85	95	°F	<ul style="list-style-type: none"> Backup unoccupied cooling set point. Used if the communications link is lost for 5 minutes between the CORE Unit Controller and network control panel. Used only in room sensor applications. Set point temperature must be greater than or equal to Parameter 138 plus Parameter 152).
141	AFTERHOUR OVRRD DLY	After Hours Override Time Delay	0	60	480	Minutes	<ul style="list-style-type: none"> After hours override timer. Only used on room sensor applications without a network control panel.
142	HEAT STAGE DEADBAND	Heat Stage Deadband	1	1	3.75	°F	<ul style="list-style-type: none"> Heating dead-band. Used only with CORE Unit Controller room sensor applications. Dead band must be less than or equal to Parameter 152 minus Parameter 143.
143	COOL STAGE DEADBAND	Cool Stage Deadband	1	1	3.75	°F	<ul style="list-style-type: none"> Cooling dead-band. Used only with room sensor applications. Dead band must be less than or equal to Parameter 152 minus Parameter 142.
144	COOL STAGE1 DIFFER	Cooling Stage 1 Differential	0	0.5	3	°F	<ul style="list-style-type: none"> Cooling stage 1 differential. Used only with room sensor applications. Differential temperature must be less than or equal to Parameter 145.
145	COOL STAGE2 DIFFER	Cooling Stage 2 Differential	0	1	3	°F	<ul style="list-style-type: none"> Cooling stage 2 differential. Used only with room sensor applications. Differential temperature must be greater than or equal to Parameter 144 and less than or equal to Parameter 146.
146	COOL STAGE3 DIFFER	Cooling Stage 3 Differential	0	1.5	3	°F	<ul style="list-style-type: none"> Cooling stage 3 differential. Used only with room sensor applications. Differential temperature must be greater than or equal to Parameter 145 and less than or equal to Parameter 147.

Table 12. CORE Control System Unit Parameters

Control Parameter No	Screen Name	Parameter Short Description	Control Value			Units	Description
			Min.	Default	Max.		
147	COOL STAGE4 DIFFER	Cooling Stage 4 Differential	0	2	3	°F	<ul style="list-style-type: none"> Cooling stage 4 differential. Used only with room sensor applications. Differential temperature must be greater than or equal to Parameter 146.
148	HEAT STAGE1 DIFFER	Heating Stage 1 Differential	0	0.5	3	°F	<ul style="list-style-type: none"> Heating stage 1 differential. Used only with room sensor applications. Differential temperature must be less than or equal to Parameter 149.
149	HEAT STAGE2 DIFFER	Heating Stage 2 Differential	0	1	3	°F	<ul style="list-style-type: none"> Heating stage 2 differential. Used only with room sensor applications. Differential temperature must be greater or equal to Parameter 148.
150	HEAT STAGE3 DIFFER	Heating Stage 3 Differential	0	1.5	3	°F	<ul style="list-style-type: none"> Heating stage 3 differential temperature. Used only with room sensor applications. Differential temperature must be greater than or equal to Parameter 149.
151	HEAT STAGE4 DIFFER	Heating Stage 4 Differential	0	2	3	°F	<ul style="list-style-type: none"> Heating stage 4 differential temperature. Used only with room sensor applications. Differential temperature must greater than or equal to Parameter 150.
152	AUTO CHGOVR DEADBND	Automatic Changeover Deadband	2	3	10	°F	<ul style="list-style-type: none"> Minimum auto changeover dead-band temperature. Dead band must be greater than or equal to Parameter 142 plus Parameter 143. Used in room sensor applications.
153	AUTO CHGOVR DELAY	Automatic Changeover Delay	1	Default may be altered at factory test.	15	Minutes	Auto changeover time delay. Delay between heating and cooling modes.
154	OCC BLOWER MODE	Occupied Blower Mode		AUTO-CYCLES		Option	<p>Blower control option for room sensor applications during occupied periods.</p> <ul style="list-style-type: none"> Auto Cycle: Blower cycles with demand On-Continuous 1: blower is on with either the occupancy sensor or occupancy schedule indicates occupied. On-Continuous 2: Blower is on only when both the occupancy sensor and occupancy scheduler indicates occupied. On-Continuous 3: lower is on only when both the occupancy sensor and occupancy scheduler indicates occupied. in addition, blower will be on a minimum of 25% of the time when occupancy scheduler indicates occupied by the occupancy sensor indicates not occupied. The 25% minimum is achieved by turning blower on for 30 minutes and off for 90 minutes.
155	FREECOOL LOCKOUT SP	Free Cooling Lockout Set Point	30	30	60	°F	<ul style="list-style-type: none"> Locks out free cooling when outdoor temperature is below the set value. Setting value to 29°F disables free cooling lockout.
156	FRESH AIR HEAT SP	See CORE System Application Guide for further details and to change the fresh air heat (FAH) set point. Modify the set point only using the method described in the reference section.					

Table 12. CORE Control System Unit Parameters

Control Parameter No	Screen Name	Parameter Short Description	Control Value			Units	Description
			Min.	Default	Max.		
157	FAH STAGE DEADBAND	Fresh Air Heating Stage Deadband	3	10	15	°F	Fresh Air Heating stage dead-band.
158	FAH MIN CYCLE TIME	Fresh Air Heating Minimum Cycle Time	120	480	1800	Seconds	Fresh Air heating minimum cycle time.
159	FREE COOL SUPPLY SP	Free Cooling Supply Set Point	45	55	65	°F	Economizer modulates dampers to maintain supply air temperature (RT6) at this set point during free cooling. DACC reset applies. See Parameter 207 - Parameter 201
160	ECON FREECL TEMP SP	Economizer Free Cooling Temperature Set Point	40	60	75	°F	Outdoor Air Temperature is less than Parameter Set Point between 41-75°F, or when Outdoor Air temperature is less than Return Air Temperature between 0-40°F.
161	ECON FRCL TMP OFFSET	Economizer Free Cooling Temperature Offset	0	10	40	°F	Economizer Free Cooling Temperature Offset
162	ECON FREECL ENTH SP	Economizer Free Cooling Enthalpy Set Point	10	12	19	mA	Economizer Free Cooling Enthalpy Set Point
163	ECN FRCL ENTH OFFST	Economizer Free Cooling Enthalpy Offset	1	1	5	mA	Economizer Free Cooling Enthalpy Offset

Table 12. CORE Control System Unit Parameters

Control Parameter No	Screen Name	Parameter Short Description	Control Value			Units	Description
			Min.	Default	Max.		
164	ECONOMIZER PROFILE	Economizer Profile	0	2	3	Option	<p>These are the operating profile options for the economizer damper during free cooling when any compressor is on and can be selected as follows:</p> <ul style="list-style-type: none"> Option 0: Damper continues to modulate while compressors are on, but the effect of mechanical cooling may force the damper closed to its minimum position. After compressor starts, the free cooling setpoint is lowered to a fixed temperature of 45°F. Option 1: Damper opens to its maxopen position (Parameter 131 - FREE CL MAX DAMPER) when any compressors start. <p>NOTE: When using Option 1 and after the compressor is stopped, the M3 will resume damper modulation.</p> <ul style="list-style-type: none"> Option 2: Damper continues to modulate while compressors are on, but the effect of mechanical cooling may force the damper closed to its minimum position. This is the factory default setting. <ul style="list-style-type: none"> > Holds off compressor on Y2 call until damper has modulated to maximum position (Parameter 131 - FREE CL MAX DAMPER) for three minutes. > After three minutes, compressor starts and the free cooling setpoint is lowered to 45°F. Damper is not locked at maximum open while compressor is on, but modulates to maintain 45°F discharge air temperature. > When Y2 is satisfied, compressor goes off and free cooling setpoint is restored to 55°F (Parameter 159 - FREE COOL SUPPLY SP). Option 3: Same as Option 2, but with a 10 minute delay instead of a three minute delay.
System 2 Parameters							
165	FAH STAGE DIFFER	Fresh Air Heating Stage Differential	0	2	20	°F	<ul style="list-style-type: none"> Fresh Air Heating stage differential. 0 value for first stage heating only for Fresh Air Heating.
166	FAH REHEAT OAT SP	Fresh Air Heating Control Reheat Outdoor Air Temperature Set Point	20	45	60	°F	Outdoor air temperature set point that enables fresh air heating for reheat demand and opens damper to Parameter 167 when outdoor air is less than set point.
167	FAH REHEAT DAMPER	Fresh Air Heating Control Reheat Damper Position	5	40	100	%	Fresh air damper position during Fresh Air Heating reheat operation.
168	FAH REHEAT SP	Fresh Air Heat Control Set Point	40	40	70	°F	Fresh Air Heating Reheat set point.

Table 12. CORE Control System Unit Parameters

Control Parameter No	Screen Name	Parameter Short Description	Control Value			Units	Description
			Min.	Default	Max.		
169	FAT AUTO CHGOVR DLY	Fresh Air Tempering Automatic Changeover Delay	15	30	120	Minutes	Fresh Air Heating Control or Fresh Air Cooling Control air Tempering auto-changeover delay.
170	FRESH AIR COOL SP	See CORE System Application Guide for further details and to change the fresh air cool (FAC) set point. Modify the set point only using the method described in the reference section.					
171	FAC STAGE DEADBAND	Fresh Air Cooling Control Deadband	3	10	15	°F	Fresh Air Cooling stage dead-band.
172	FAC MIN CYCLE TIME	Fresh Air Cooling Control Cycle Time	120	480	1800	Seconds	Fresh Air Cooling minimum cycle time.
173	FAC STAGE DIFFER	Fresh Air Cooling Control Stage Differential	0	2	20	°F	<ul style="list-style-type: none"> Fresh Air Cooling stage differential between stages. Set to 0 for first stage cooling only for Fresh Air Cooling.
174	DACH OCC SETPOINT	Discharge Air Control Heating Occupied Set Point	60	110	140	°F	Discharge Air Control Heating set point during occupied period.
175	DACH UNOCC SETPOINT	Discharge Air Control Heating Unoccupied Set Point	60	95	140	°F	Discharge Air Control Heating set point during unoccupied period.
176	DACH STAGE DEADBAND	Discharge Air Control Heating Stage Deadband	5	5	20	°F	Discharge Air Control Heating dead-band.
177	DACH FAH STG UP TMR	Discharge Air Control Heating Stage-Up Time Delay	0	180	900	Seconds	Discharge Air Control Heating and Fresh Air Heating stage-up time delay.
178	DACH FAH STG DN TMR	Discharge Air Control Heating and Fresh Air Heating Control Stage-Down Time Delay	0	120	600	Seconds	Discharge Air Control Heating and Fresh Air Heating stage-down time delay.
179	DACH STAGE DIFFER	Discharge Air Control Heating Stage Differential	2	2	20	°F	Discharge Air Control Heating stage differential
180	DACC OCC SETPOINT	Discharge Air Control Cooling Occupied Set Point	40	55	80	°F	Discharge Air Control Cooling set point during occupied period.
181	DACC UNOCC SETPOINT	Discharge Air Control Cooling Unoccupied Set Point	40	65	100	°F	Discharge Air Control Cooling set point during unoccupied period.
182	DACC STAGE DEADBAND	Discharge Air Control Cooling Deadband Set Point	5	5	20	°F	Discharge Air Control Cooling stage dead-band.
183	DACC FAC STG UP TMR	Discharge Air Control Cooling and Fresh Air Cooling Stage-Up Delay	0	180	900	Seconds	Discharge Air Control Cooling and Fresh Air Cooling stage-up delay.
184	DACC FAC STG DN TMR	Discharge Air Control Cooling and Fresh Air Cooling Stage-Down Time Delay	0	120	600	Seconds	Discharge Air Control Cooling and Fresh Air Cooling stage-down time delay.

Table 12. CORE Control System Unit Parameters

Control Parameter No	Screen Name	Parameter Short Description	Control Value			Units	Description
			Min.	Default	Max.		
185	DACC STAGE DIFFER	Discharge Air Cooling Stage Differential	2	2	20	°F	Discharge Air Cooling stage differential.
186	SRV OUTPT CTRL MODE	Service Output Control Mode	0	0	127	Option	<p>A55 Service Output Control Mode = X + 32*Y + 16*Z</p> <p>Input source = X:</p> <ul style="list-style-type: none"> • 0 = None • 1 = Compressor 1 duty cycle. (Compressor crankcase heater function.) <ul style="list-style-type: none"> > On when outdoor air temperature is less than or equal to Parameter 189 and greater than or equal to Parameter 192 seconds have passed with compressor 1 off. > Off when Outdoor Air temperature is greater than Parameter 189 plus 3°F (fixed dead-band) or is less than Parameter 192 seconds have passed with compressor 1 off • 2 = On when occupied. • 3 = On when blower on, • 4 = On when heating demand. • 5 = On when cooling demand. • 6 = On when heating or cooling demand. • 7 = System Relative Humidity (A55_P298_5 RH) • 8 = System Indoor Air Quality. (A55_P298_3 IAQ) • 9 = System Outdoor Air Temperature (A55_P267_1/2 OAT) • 10 = Energy Recovery System • 11 = SCR Option for Electric Heat <p>Algorithm Y for input sources 7 - 9:</p> <ul style="list-style-type: none"> • 0 = Hysteresis loop (see sections 14.2 - 14.4) • 1 = Window - On when input is in range; (see sections 14.2 - 14.4) • 2 = Delayed-on. (see sections 14.2 - 14.4) • 3 = Delayed-off. (see sections 14.2 - 14.4) <p>Inversion Z:</p> <ul style="list-style-type: none"> • 0- Output not inverted. • 1- Output inverted.
187	SRV OUTPT SP C02	Service Output Set Point for Carbon Dioxide	0	996	2000	ppm	A55 service relay output set point.
188	SRV OUTPT SP RH	Service Output Set Point for Relative Humidity	0	100	100	%	Service Output Set Point for Relative Humidity
189	SRV OUTPT SP TEMP	Service Output Set Point Temperature	-31	51	132	°F	Service Output Set Point Temperature
190	SRV OUTPT DB C02	Service Output Deadband for Carbon Dioxide	16	102	2000	ppm	A55 service relay output dead-band or delay.

Table 12. CORE Control System Unit Parameters

Control Parameter No	Screen Name	Parameter Short Description	Control Value			Units	Description
			Min.	Default	Max.		
191	SRV OUTPT DB RH	Service Output Deadband for Relative Humidity	2	13	100	%	Service Output Deadband for Relative Humidity
192	SRV OUTPT DB TEMP	Service Output Deadband for Temperature	1	8	162	°F	Service Output Deadband for Temperature
193	SRV OUTPT DELAY	Service Output Delay	64	416	8160	Seconds	Service Output Delay
194	LOAD SHED NUM COMP	Number of compressors to shed during load shedding	0	0	4	Option	Number of compressors to be turned off when load shedding is active. Applicable to Standard Efficiency 3- to 6-ton units only. 2-stage compressor, a value of one shuts off 2nd stage only and a value of 2 turns compressor completely off.
196	MAC ADDRESS	MAC Address	0	128	128	Address	BACnet MAC Address. A value of 0-128 sets the BACnet MAC address to that value.
197	BAUD RATE	Baud Rate		9.6K 19.2K 38.4K 76.8K		Option	Baud rate setting.
System 3 Parameters							
201	DACC OAT RS ADJ BND	Discharge Air Control Cooling Outdoor Air Temperature Adjustment Band	0	0	30	°F	<ul style="list-style-type: none"> Discharge Air Control Cooling outdoor temperature ambient cooling adjustment reset band. Also used to reset free cooling set point (Parameter 159).
202	DACC OAT RS ADJ SP	Discharge Air Control Cooling Outdoor Air Temperature Cooling Reset Set Point	40	80	100	°F	<ul style="list-style-type: none"> Discharge Air Control Cooling outdoor air temperature cooling reset set point. Also used to reset free cooling set point (Parameter 159).
203	DACC OAT RS PRP BND	Discharge Air Control Cooling Outdoor Ambient Air Temperature Cooling Proportional Band	1	20	60	°F	<ul style="list-style-type: none"> Discharge Air Control Cooling outdoor ambient temperature cooling proportional band. Also used to reset free cooling set point (Parameter 159).
204	DACC RAT RS ADJ BND	Discharge Air Control Cooling Return Air Reset Adjustment Band	0	0	30	°F	<ul style="list-style-type: none"> Discharge Air Control Cooling return air reset adjustment band. 0 disables return air cooling reset. Also used to reset free cooling set point (Parameter 159).
205	DACC RAT RS ADJ SP	Discharge Air Control Return Air Reset Adjustment Set Point	50	70	80	°F	<ul style="list-style-type: none"> Discharge Air Control Cooling return air reset set point. Also used to reset free cooling set point (Parameter 159).
206	DACC RAT RS PRP BND	Discharge Air Control Cooling Return Air Reset Proportional Band	1	10	30	°F	<ul style="list-style-type: none"> Discharge Air Control Cooling return air reset proportional band. Also used to reset free cooling set point (Parameter 159).
207	DACC RS LIMIT	Discharge Air Control Cooling Reset Limit	5	10	20	°F	<ul style="list-style-type: none"> Discharge Air Control Cooling total reset limit. This limits the total DACC reset allowed. Also used to reset free cooling set point (Parameter 159).

Table 12. CORE Control System Unit Parameters

Control Parameter No	Screen Name	Parameter Short Description	Control Value			Units	Description
			Min.	Default	Max.		
208	DACH OAT RS ADJ BND	Discharge Air Control Heating Outdoor Air Temperature Reset Adjustment Band	0	0	30	°F	Discharge Air Control Heating outdoor temperature reset adjustment band.
209	DACH OAT RS ADJ SP	Discharge Air Control Heating Reset Adjustment Set Point	-31	40	60	°F	Discharge Air Control Heating outdoor temperature reset set point.
210	DACH OAT RS PRP BND	Discharge Air Control Heating Outdoor Air Temperature Reset Proportional Band	1	20	60	°F	Discharge Air Control Heating temperature reset proportional band.
211	DACH RAT RS ADJ BND	Discharge Air Control Heating Return Air Temperature Adjustment Band	0	0	30	°F	Discharge Air Control Heating return reset adjustment band.
212	DACH RAT RS ADJ SP	Discharge Air Control heating Return Air Heating Reset Set Point	50	70	80	°F	Discharge Air Control Heating return air heating reset set point.
213	DACH RAT RS PRP BND	Discharge Air Control Heating Return Air Heading Reset Proportional Band	1	10	30	°F	Discharge Air Control Heating return air heating reset proportional band.
214	DACH RS LIMIT	Discharge Air Control Heating Return Air Heating Reset Limit	5	10	20	°F	Discharge Air Control Heating reset limit. This limits the total DACH reset allowed.
215	EXH FN STG1 DAMP SP	Exhaust Fan Stage 1 Damper Set Point	0	50	100	%	Exhaust fan stage 1 damper set point.
216	EXH FN STG1 DAMP DB	Exhaust Fan Stage 1 Damper Deadband	0	Default may be altered at factory test.	100	%	Exhaust Fan Stage 1 Damper Deadband
217	EXH FN STG1 PRES SP or VFD PE PRES SP	Stage 1 set point or VFD PE set point	-0.5	0.05	0.5	in w.c.	Exhaust Fan Stage 1 Pressure Set Point. or VFD Power Exhaust Building Pressure Set Point.
218	EXH FN STG1 PRES DB	Stage 1 deadband	0	0.02	1	in w.c.	Exhaust Fan Stage 1 Pressure Deadband.
219	EXH FN STG2 DAMP SP	Exhaust Fan Stage 2 Damper Set Point	0	75	100	%	Exhaust Fan Stage 2 Damper Set Point
220	EXH FN STG2 DAMP DB	Exhaust Fan Stage 2 Damper Deadband	0	10	100	%	Exhaust Fan Stage 2 Damper Deadband
221	EXH FN STG2 PRES SP	Stage 2 setpoint	-0.5	0.10	0.5	in w.c.	Exhaust Fan Stage 2 Pressure Set Point
222	EXH FN STG2 PRES DB	Stage 2 deadband	0	0.05	1	in w.c.	Exhaust Fan Stage 2 Pressure Deadband.
223	EXH FAN STGUP DELAY	Exhaust Fan Stage Up Delay	0	100	300	Seconds	Exhaust Fan Stage Up Delay
224	EXH FAN STGDWN DLAY	Exhaust Fan Stage Down Delay	0	100	200	Seconds	Stage 1 off-delay. (Only used for 2 stage operation)

Table 12. CORE Control System Unit Parameters

Control Parameter No	Screen Name	Parameter Short Description	Control Value			Units	Description
			Min.	Default	Max.		
228	CL LO CFM CALIB	Advanced Airflow Low Speed Calibration	-1200	0	1200	Count	<ul style="list-style-type: none"> Applicable to Standard Efficiency 3- to 6-ton units only. If the absolute value of this Parameter is greater than Parameter 17, then this is not considered in target calculation.
229	CL HI SPD CALIB	Advanced Airflow Hi Speed Calibration	-1200	0	1200	Count	<ul style="list-style-type: none"> Applicable to Standard Efficiency 3- to 6-ton units only. If the absolute value of this Parameter is greater than Parameter 14, then this is not considered in target calculation
230	CL MED LO SPD CALIB	Advanced Airflow Medium Speed Calibration	-1200	0	1200	Count	Applicable to Standard Efficiency 3- to 6-ton units only.
231	CL MED HI SPD CALIB	Advanced Airflow Medium High Speed Calibration	-1200	0	1200	Count	Applicable to Standard Efficiency 3- to 6-ton units only.
232	HEAT CFM CALIB	Advanced Airflow Heat CFM Calibration	-1200	0	1200	Count	Applicable to Standard Efficiency 3- to 6-ton units only.
233	VENT CFM CALB	Advanced Airflow Vent CFM Calibration	-1200	0	1200	Count	Applicable to Standard Efficiency 3- to 6-ton units only.
234	LO SP CFM ALARM SP	Advanced Airflow Low Speed CFM Alarm Set Point	15	25	100	%	Applicable to Standard Efficiency 3- to 6-ton units only.
235	LO SP CFM ALARM EU	Advanced Airflow Low Speed CFM Alarm Evaluation	0	1800	3600	Seconds	Applicable to Standard Efficiency 3- to 6-ton units only.
236	NO AIRFLOW ALARM EU	Advanced Airflow No Airflow Alarm Evaluation	0	20	300	Count	Applicable to Standard Efficiency 3- to 6-ton units only.
237	OUTDOOR AIR TARGET	Outdoor Air Target	0	0	750	CFM	Applicable to Standard Efficiency 3- to 6-ton units only.
238	OUTDOOR CFM CALIB	Advanced Airflow Outdoor CFM Calibration	-600	0	600	Count	Applicable to Standard Efficiency 3- to 6-ton units only.
239	LO OD CFM ALARM SP	Advanced Airflow Outdoor CFM Alarm Set Point	15	25	100	%	Applicable to Standard Efficiency 3- to 6-ton units only.
240	HI OD CFM ALARM SP	Advanced Air Flow High Outdoor CFM Alarm Set Point	15	25	100	%	Applicable to Standard Efficiency 3- to 6-ton units only.
241	MAX OD CFM DCV SP	Advanced Airflow Maximum Outdoor CFM Demand Control Ventilation Set Point	0	600 (3-ton Unit) 800 (4-ton Unit) 1000 (5-ton Unit)	2400	CFM	Applicable to Standard Efficiency 3- to 6-ton units only.
243	LO OD CFM ALARM EU	Advanced Air Flow Low Outdoor CFM Alarm Evaluation	0	1800	3600	Seconds	Applicable to Standard Efficiency 3- to 6-ton units only.
244	HI OD CFM ALARM EU	Advanced Air Flow High Outdoor CFM Alarm Evaluation	0	1800	3600	Seconds	Applicable to Standard Efficiency 3- to 6-ton units only.
245	OD DP ERR ALARM EU	Advanced Airflow Outdoor Air Damper Error Alarm Evaluation	0	1800	3600	Seconds	Applicable to Standard Efficiency 3- to 6-ton units only.

Table 12. CORE Control System Unit Parameters

Control Parameter No	Screen Name	Parameter Short Description	Control Value			Units	Description																						
			Min.	Default	Max.																								
246	ALTITUDE STPT	Advanced Airflow Altitude Set Point	0	650	25000	Feet	Applicable to Standard Efficiency 3- to 6-ton units only.																						
247	BLR CALIB RAMP RATE	Blower Calibration Ramp Rate	4	10	40	%	Applicable to Standard Efficiency 3- to 6-ton units only.																						
258	DISPLAY UNITS F/C	Display Unit (Fahrenheit or Celsius)		FAHRENHEIT or CELSIUS		Option	Temperature unit of measurement.																						
285	FRCL COMP LCKOUT MD	Free Cooling Compressor Lockout Mode	0	2	2	Option	<ul style="list-style-type: none"> 0 = Disable Free Cooling Low Ambient Compressor Lockout (default). 1 = Lockout Compressor whenever the outdoor air is suitable regardless of outdoor air temperature. 2 = Enable Free Cooling Low Ambient Compressor Lockout. 																						
287	ALGORITHMS ENABLED	Algorithms Enabled	<p>NOTE: Options for Parameter 287 are not accessible via the CORE Unit Controller user interface. Options can be set using the Lennox UC software.</p> <p>Here is an example of the selection options for Algorithms Enable via the Lennox UC Software:</p> <table border="1"> <thead> <tr> <th>Set Bit</th> <th>Description</th> </tr> </thead> <tbody> <tr> <td>0x00000002</td> <td>Enable Fresh Air Heating (ALGO_FAH)</td> </tr> <tr> <td>0x00000004</td> <td>Enable Fresh Air Cooling (ALGO_FAC)</td> </tr> <tr> <td>0x00000008</td> <td>Enable DACC Return Air Reset (ALGO_DACC_RAT_RESET)</td> </tr> <tr> <td>0x00000010</td> <td>Enable DACC Outdoor Air Reset (ALGO_DACC_OAT_RESET)</td> </tr> <tr> <td>0x00000020</td> <td>Enable DACH Return Air Reset (ALGO_DACH_RAT_RESET)</td> </tr> <tr> <td>0x00000040</td> <td>Enable DACH Outdoor Air Reset (ALGO_DACH_OAT_RESET)</td> </tr> <tr> <td>0x00000080</td> <td>Enable Supply Static Pressure Sensor Alarm (ALGO_LO_STATIC_PRESSURE_ALARM)</td> </tr> <tr> <td>0x00000100</td> <td>Enable Low Outdoor Temp override of DCV/OAC operation (ALGO_LO_OAT_DCV_OAC_OVERRIDE)</td> </tr> <tr> <td>0x00000200</td> <td>Enable High Outdoor Temp override of DCV/OAC operation (ALGO_HI_OAT_DCV_OAC_OVERRIDE)</td> </tr> <tr> <td>0x00000800</td> <td>Enable Free Cooling Blower Stage Up</td> </tr> </tbody> </table>					Set Bit	Description	0x00000002	Enable Fresh Air Heating (ALGO_FAH)	0x00000004	Enable Fresh Air Cooling (ALGO_FAC)	0x00000008	Enable DACC Return Air Reset (ALGO_DACC_RAT_RESET)	0x00000010	Enable DACC Outdoor Air Reset (ALGO_DACC_OAT_RESET)	0x00000020	Enable DACH Return Air Reset (ALGO_DACH_RAT_RESET)	0x00000040	Enable DACH Outdoor Air Reset (ALGO_DACH_OAT_RESET)	0x00000080	Enable Supply Static Pressure Sensor Alarm (ALGO_LO_STATIC_PRESSURE_ALARM)	0x00000100	Enable Low Outdoor Temp override of DCV/OAC operation (ALGO_LO_OAT_DCV_OAC_OVERRIDE)	0x00000200	Enable High Outdoor Temp override of DCV/OAC operation (ALGO_HI_OAT_DCV_OAC_OVERRIDE)	0x00000800	Enable Free Cooling Blower Stage Up
Set Bit	Description																												
0x00000002	Enable Fresh Air Heating (ALGO_FAH)																												
0x00000004	Enable Fresh Air Cooling (ALGO_FAC)																												
0x00000008	Enable DACC Return Air Reset (ALGO_DACC_RAT_RESET)																												
0x00000010	Enable DACC Outdoor Air Reset (ALGO_DACC_OAT_RESET)																												
0x00000020	Enable DACH Return Air Reset (ALGO_DACH_RAT_RESET)																												
0x00000040	Enable DACH Outdoor Air Reset (ALGO_DACH_OAT_RESET)																												
0x00000080	Enable Supply Static Pressure Sensor Alarm (ALGO_LO_STATIC_PRESSURE_ALARM)																												
0x00000100	Enable Low Outdoor Temp override of DCV/OAC operation (ALGO_LO_OAT_DCV_OAC_OVERRIDE)																												
0x00000200	Enable High Outdoor Temp override of DCV/OAC operation (ALGO_HI_OAT_DCV_OAC_OVERRIDE)																												
0x00000800	Enable Free Cooling Blower Stage Up																												
305	LON HEARTBEAT TIME	LonTalk Heartbeat Time	0	100	10,000	Seconds	Heartbeat configuration proprieties define how often a network variable update is transmitted from a sending node.																						
313	FAH REHEAT MODE	Fresh Air Reheat Mode	0	0	3	Option	<ul style="list-style-type: none"> 0 = Disabled 1 = Allowed, must be occupied 2 = Allowed, blower must be energized and in occupied mode. 3 = Allow. No conditions apply. 																						
314	MSAV MIN VFD DR OUT	MSAV Minimum VFD Drive Output	10	33	50	%	The CORE Unit Controller will ensure that active VFD drive output is equal or greater than Minimum VFD drive output. If conversion from CFM setting to VFD drive yields lower value. The system will use Minimum VFD drive output instead output.																						
317	OUT AIR UNIT OPTNS	Outdoor Air Unit Options	0	0	2	Option	This Parameter is applicable in Zone Sensor mode (i.e. not applicable for local/ remote thermostat mode).																						
321	ENTH HIGH TMP LIMIT	Enthalpy High Temperature Limit	45	75	85	°F	When in Enthalpy mode, the outdoor air suitability (OAS) will be set only if the outdoor air temperature is lesser than this Parameter set point.																						
323	ZON SNSR CAL OFFSET	Zone Sensor Calibration Offset	-5	0	5	°F	This setting is applicable to local temperature sensor only.																						
327	BPC MANUAL RESET	Building Pressure Control Manual Reset	0	50	100	%	Manual reset value. This Parameter defines the default outdoor air damper position																						

Table 12. CORE Control System Unit Parameters

Control Parameter No	Screen Name	Parameter Short Description	Control Value			Units	Description
			Min.	Default	Max.		
328	BPC PID P CONST	Building Pressure Control PID P Constant	0	100	127	Count	BPC PID Proportional Constant
329	BPC PID I CONST	Building Pressure Control PID I Constant	0	30	127	Count	BPC PID Integral Constant
330	GP A02 MODE	General Purpose A02 Mode	0	0	12	Mode Selection	<ul style="list-style-type: none"> • 1 - Occupied - PID set point A; Unoccupied - PID set point B • 2 - Occupied - PID set point A; Unoccupied - Staged output B • 3 - Occupied - Staged output A; Unoccupied - PID set point B • 4 - Occupied - Staged output A; Unoccupied - Staged output B • 5 - Blower On - PID set point A; Blower Off - PID set point B • 6 - Blower On - PID set point A; Blower Off - Staged output B • 7 - Blower On - Staged output A; Blower Off - PID set point B • 8 - Blower On - Staged output A; Blower Off - Staged output B • 9 - DI2 on - PID set point B (1); DI3 on - PID set point A (2); Otherwise off. • 10 - DI2 on - PID set point B (1); DI3 on - Staged Output A (2); Otherwise off. • 11 - DI2 on - PID set point B (1); DI3 on - Staged Output A (2); Otherwise off. • 12 - Reserved • (1) -DI3 (on M3) doesn't matter • (2) -DI2 (on M3) is off
331	GP A02 SP A	General Purpose A02 Set Point A	0	0	100	%	Analog output channel 2, set point A.
332	GP A02 SP B	General Purpose A02 Set Point B	0	0	100	%	Analog output channel 2, set point B.
333	GP A02 STG A	General Purpose A02 Stage A	0	0	100	%	Analog output channel 2, stage A
334	GP A02 STG B	General Purpose A02 Stage B	0	0	100	%	Analog output channel 2, stage B
335	GP A02 OUTPUT	General Purpose A02 Output	0	0	1	Selection	<ul style="list-style-type: none"> • 0 = PWM • 1 = 0-10 VDC
336	GP A02 PWM FREQ	General Purpose A02 Pulse-Width Modulation Frequency	50	200	2000	Hz	Analog output PWM frequency.
337	GP A02 KP	General Purpose A02 Proportional Constant for PID	0	0	100	Count	Analog output channel 2 PID loop proportional constant.
338	GP A02 KI	General Purpose A02 Integral Constant for PID	0	0	100	Count	Analog output channel 2 PID loop integral constant.
340	GP A02 MIN OUPUT	General Purpose A02 Minimum Output	0	0	100	%	Analog output channel 2 minimum output.
341	GP A02 MAX OUPUT	General Purpose A02 Maximum Output	0	100	100	%	Analog output channel 2 maximum output.

Table 12. CORE Control System Unit Parameters

Control Parameter No	Screen Name	Parameter Short Description	Control Value			Units	Description
			Min.	Default	Max.		
342	GP A02 SOURCE	General Purpose A02 Source	1	1	3	Selection	Source/feedback for the PID loop. <ul style="list-style-type: none"> 1 = Analog input 1 on GP3 A02 2 = Analog input 2 on GP3 A02 3 = Analog input 3 on GP3 A02
343	GP A02 CYCL INTRVL	General Purpose A02 Cycle Interval	0	1	180	Seconds	Frequency of execution of PID loop.
344	GP A03 MODE	General Purpose A03 Mode	0	0	11	Mode Selection	<ul style="list-style-type: none"> 1 - Occupied - PID set point A; Unoccupied - PID set point B 2 - Occupied - PID set point A; Unoccupied - Staged output B 3 - Occupied - Staged output A; Unoccupied - PID set point B 4 - Occupied - Staged output A; Unoccupied - Staged output B 5 - Blower On - PID set point A; Blower Off - PID set point B 6 - Blower On - PID set point A; Blower Off - Staged output B 7 - Blower On - Staged output A; Blower Off - PID set point B 8 - Blower On - Staged output A; Blower Off - Staged output B 9 - DI2 on - PID set point B (1); DI3 on - PID set point A (2); Otherwise off. 10 - DI2 on - PID set point B (1); DI3 on - Staged Output A (2); Otherwise off. 11 - DI2 on - PID set point B (1); DI3 on - Staged Output A (2); Otherwise off. 12 - Reserved (1) -DI3 (on M3) doesn't matter (2) -DI2 (on M3) is off
345	GP A03 SP A	General Purpose A03 Set Point A	0	0	100	%	Analog output channel 3, set point A.
346	GP A03 SP B	General Purpose A03 Set Point B	0	0	100	%	Analog output channel 3, set point B.
347	GP A03 STG A	General Purpose A03 Stage A	0	0	100	%	Analog output channel 3, stage A
348	GP A03 STG B	General Purpose A02 Stage B	0	0	100	%	Analog output channel 3, stage B
349	GP A03 OUTPUT	General Purpose A03 Output	0	0	1	Selection	<ul style="list-style-type: none"> 0 = PWM 1 = 0-10 VDC
350	GP A03 PWM FREQ	General Purpose A03 Pulse-Width Modulation Frequency	50	200	2000	Hz	Frequency of execution of PID loop.
351	GP A03 KP	General Purpose A03 Proportional Constant	0	0	100	Count	Analog output channel 3 PID loop proportional constant.
352	GP A03 KI	General Purpose A03 Integral Constant	0	0	100	Count	Analog output channel 3 PID loop integral constant.
354	GP A03 MIN OUPUT	General Purpose A03 Minimum Output	0	0	100	%	Analog output channel 3 minimum output.

Table 12. CORE Control System Unit Parameters

Control Parameter No	Screen Name	Parameter Short Description	Control Value			Units	Description
			Min.	Default	Max.		
355	GP A03 MAX OUTPUT	General Purpose A03 Maximum Output	0	100	100	%	Analog output channel 3 Maximum output.
356	GP A03 SOURCE	General Purpose A03 Source	1	1	3	SOURCE	Source/feedback for the PID loop. <ul style="list-style-type: none"> • 1 = Analog input 1 on GP3 A03 • 2 = Analog input 2 on GP3 A03 • 3 = Analog input 3 on GP3 A03
357	GP A03 CYCL INTRVL	General Purpose A03 Cycle Interval	0	1	180	Seconds	Frequency of execution of PID loop.
358	GP D01 MODE	General Purpose D01 Mode	0	0	127	Input Source	<p>GP3 Digital Out Control Mode = $X + 32*Y + 16*Z$</p> <p>Input Sources X:</p> <ul style="list-style-type: none"> • 0 = None. • 1 = Compressor 1 duty cycle. (Compressor crankcase heater function) <ul style="list-style-type: none"> > On when outdoor air temperature is \geq Parameter 364 seconds have passed with compressor 1 off. > Off when outdoor air temperature $>$ Parameter 362 + 3°F (fixed dead-band) or compressor 1 is turned on. • 2 = On when Occupied • 3 = On when blower on. • 4 = On when heating demand • 5 = On when cooling demand • 6 = On when heating or cooling demand • 7 = System RH (use Parameter 361) • 8 = System IAQ (use Parameter 360) • 9 = System OAT (use Parameter 362) • 10 = On based on GP3 Temperature Sensor 1 (use Parameter 362) • 11 = On based on GP3 Temperature Sensor 2 (use Parameter 362) • 12 = On based on GP3 AI1 (use Parameter 359) • 13 = On based on GP3 AI2 (use Parameter 359) • 14 = On based on GP3 AO1 (use Parameter 359) • 15 = On based on GP3 AO2 (use Parameter 359) • Algorithm Y for Input Sources 7-15 (see 507242-01, Prodigy Application Guide for further details).
359	GP D01 SP VOLTS	General Purpose D01 Set Points Volts	0	0	10	Volts	General Purpose D01 Digital output control mode set point.
360	GP D01 SP PPM	General Purpose D01 Set Point Parts Per Million	21	996	1996	PPM	General Purpose D01 Digital output control mode set point.
361	GP D01 SP PERCENT	General Purpose D01 Set Point Percentage	0	0	100	%	General Purpose D01 Digital output control mode set point.

Table 12. CORE Control System Unit Parameters

Control Parameter No	Screen Name	Parameter Short Description	Control Value			Units	Description
			Min.	Default	Max.		
362	GP D01 SP DEGREES	General Purpose D01 Set Point Degree	-31	0	132	°F	General Purpose D01 Digital output control mode set point.
363	GP D01 DB PERCENT	General Purpose D01 Dead Band Percentage	0	0	100	%	General Purpose D01 Digital output control mode set point. EXAMPLE: <i>If this Parameter is set to 10%, then the dead-band in Fahrenheit would be (DO Temperature Set Point * 10 /100).</i>
364	GP D01 TIME DELAY	General Purpose D01 Time Delay	1	416	8160	Seconds	For delay on or delay off.
365	GP D02 MODE	General Purpose D02 Mode	0	0	127	Mode Selection	<p>GP3 Digital Out Control Mode = $X + 32*Y + 16*Z$</p> <p>Input Sources X:</p> <ul style="list-style-type: none"> • 0 = None. • 1 = Compressor 1 duty cycle. (Compressor crankcase heater function) <ul style="list-style-type: none"> > On when outdoor air temperature is \leq Parameter 369 and \geq P 371 seconds have passed with compressor 1 off. > Off when outdoor air temperature $>$ Parameter 369 + 3°F (fixed dead-band) or compressor 1 is turned on. • 2 = On when Occupied • 3 = On when blower on. • 4 = On when heating demand • 5 = On when cooling demand • 6 = On when heating or cooling demand • 7 = System RH (use Parameter 368) • 8 = System IAQ (use Parameter 367) • 9 = System OAT (use Parameter 369) • 10 = On based on GP3 Temperature Sensor 1 (use Parameter 369) • 11 = On based on GP3 Temperature Sensor 2 (use Parameter 369) • 12 = On based on GP3 AI1 (use Parameter 366) • 13 = On based on GP3 AI2 (use Parameter 366) • 14 = On based on GP3 AO1 (use Parameter 366) • 15 = On based on GP3 AO2 (use Parameter 366) • Algorithm Y for Input Sources 7-15 (see 507242-01, Prodigy Application Guide for further details).
366	GP D02 SP VOLTS	General Purpose D02 Set Point Volts	0	0	10	Volts	General Purpose D02 Digital output control mode set point.
367	GP D02 SP PPM	General Purpose D02 Set Point Parts Per Million	21	996	1996	PPM	General Purpose D02 Digital output control mode set point.

Table 12. CORE Control System Unit Parameters

Control Parameter No	Screen Name	Parameter Short Description	Control Value			Units	Description
			Min.	Default	Max.		
368	GP D02 SP PERCENT	General Purpose D02 Set Point Percentage	0	0	100	%	General Purpose D02 Digital output control mode set point.
369	GP D02 SP DEGREES	General Purpose D02 Set Point Degree	-31	0	132	°F	General Purpose D02 Digital output control mode set point.
370	GP D02 DB PERCENT	General Purpose D02 Dead Band Percentage	0	0	100	%	General Purpose D02 Digital output control mode set point.
371	GP2 D02 TIME DELAY	General Purpose D02 Time Delay	1	416	8160	Seconds	General Purpose D02 Digital output control mode set point.
375	DISCHARGE AIR CL SP	Discharge Air Cooling Set Point	45	55	65	°F	Set point used by the compressor / DAT PI in room sensor mode to determine the compressor speed.
382	BLOWER LO HT OUTPUT	Blower Low Heat Output	20	Depends on equipment	100	%	Applicable to High Efficiency 3- to 5-ton units only. Blower staged percentage output low speed; used for low heating for certain P volt models
385	BACNET & CS COEXIST	This will allow the CS8500 to act as a slave to the CORE Unit Controller and connect via BACNET.	0	0	1	Option	<ul style="list-style-type: none"> 0 = Disabled (default) (Required setting for connection with ICON system. 1 = Enabled (BACNET & CS8500 can co-exist.
386	VAV SMK PRESS SP	VAV supply static pressure set point during smoke operation	0	1	5	in w.c.	
387	VAV VT PRESS SP	VAV supply static pressure set point during ventilation	0	1	5	in w.c.	
388	VAV HT PRESS SP	VAV supply static pressure set point during heating	0	1	5	in w.c.	
389	VAV CL PRESS SP	VAV supply static pressure set point during cooling	0	1	5	in w.c.	
390	VAV MAX OUTPUT	VAV PID loop max speed	40	100	100	%	
391	VAV MANUALRESET	VAV PID loop manual reset value.	0	60	100	%	
392	MGV STARTUP DELAY	"MGV start up delay is based on the setting. For example the default startup delay is 16 seconds after moving to high fire."	4	16	300	Seconds	
393	MGV MAX	MGV PID loop min speed	60	80	100	%	
394	MGV MIN	MGV PID loop max speed	0	20	100	%	
395	MGV PID MANUAL RST	MGV PID loop manual reset value.	0	50	100	%	
396	MGV PID P CONST	MGV PID loop proportional constant	0	40	127	Counts	
397	MGV PID I CONST	MGV PID loop integral constant	0	64	127	Counts	

Table 12. CORE Control System Unit Parameters

Control Parameter No	Screen Name	Parameter Short Description	Control Value			Units	Description
			Min.	Default	Max.		
398	MGV PID D CONST	MGV PID loop derivative constant	0	0	127	Counts	
399	MGV SP HI CAB	Shift to high speed CAB when MGV output rises above this value.	0	65	100	%	
400	MGV DB HI CAB	Deadband for shifting down to low speed CAB	2	17	100	%	
401	POWER EXHAUST MODE	Power Exhaust Mode	N/A	Blower On	N/A	Options	Exhaust Fan Enable Options: <ul style="list-style-type: none"> • Blower On • Always • Occupied • External Enable
402	EXH FN LOW SPD CYCL	Low Speed Cycling.		0	1	Options	<ul style="list-style-type: none"> • 0 = Disabled • 1 - Enables Low Speed Cycling.
403	EXH FN STG1 SPEED	Speed for stage 1 when using a VFD for controlling exhaust fan in staged mode.	0	50	100	%	
404	EXH FN STG2 SPEED	Speed for stage 2 when using a VFD for controlling exhaust fan in staged mode.	0	100	100	%	
405	EXH FN SMK PRES SP	Exhaust Fan set point for PID control	-0.50	-0.50	0.50	in w.c.	
406	EXH FN MIN SPEED	Exhaust Fan PID loop min speed	0	50	100	%	
407	EXH FN MAX SPEED	Exhaust Fan PID loop max speed	0	100	100	%	
408	EXH FN MANUAL RESET	Exhaust Fan PID loop manual reset value.	0	100	100	%	
409	EXH FN P CONSTANT	Exhaust Fan PID loop proportional constant	0	20	127	Counts	
410	EXH FN I CONSTANT	Exhaust Fan PID loop integral constant	0	64	127	Counts	
411	EXG FN D CONSTANT	Exhaust Fan PID loop derivative constant	0	0	127	Counts	
412	EN FIXED BLWR SPD	Enable Fixed Blower Speed	0	0	2	Options	This Parameter is applicable to 'T' type Blower only. <ul style="list-style-type: none"> • 0 - Auto • 1 - Always run the blower at low speed • 2 - Always run the blower at high speed
414	HI CL REHEAT TMOUT	High Cool Reheat Time Out	0	0	30	Sec	Reheat run-time on call for high cooling.
415	DAMP BKLASH ADJ	Damper Backlash Adjustment	0	25	40	%	Damper overshoot percentage when moving to a more closed position. The damper will move this percentage beyond the target position, then reverse and move to the final target position.

Table 12. CORE Control System Unit Parameters

Control Parameter No	Screen Name	Parameter Short Description	Control Value			Units	Description
			Min.	Default	Max.		
416	BLOWER COOL OUTPUT	Blower Cooling High	20	Depends on equipment	100	%	Applicable to High Efficiency 3- to 5-ton units only. Blower staged percentage output high speed; used for high cooling or ventilation,

16. CORE Control System Inputs and Outputs

16.1. CORE Unit Controller (A55) Input/Outputs

Table 13. J304 (S-Bus)

P304	LABEL	SIGNAL DESCRIPTION	SIGNAL TYPE
-	B	RS485, B(-) inverting	0-5VDC
S	G	Ground, Current Limiting	GND
+	A	RS485, A(+) non-inverting	0-5VDC

1 0
2 0
3 0

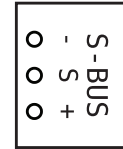

J304
S-BUS

Table 14. J299 (Digital Input)

P299	LABEL	SIGNAL DESCRIPTION	SIGNAL TYPE
DI1	A173-SMOKE	Smoke Sensor	SW 24VAC IN
R	T1	Smoke 24VAC Power	24VAC OUT
C	GND	Ground	GND
DI2	DI2	Digital Input 2	SW 24VAC IN
R	T1	24VAC Power	24VAC OUT
DI3	DI3	Digital Input 3	SW 24VAC IN
R	T1	24VAC Power	24VAC OUT
DI4	HUMD_ST	Humidistat	SW 24VAC IN
C	COM	Ground	GND
		Not Used	

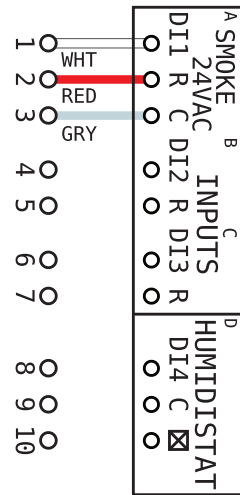

J299
DIGITAL INPUTS

Table 15. J297 (TSTAT Inputs and Service Relays)

P297	LABEL	SIGNAL DESCRIPTION	SIGNAL TYPE
R	T1	24VAC Power	24VAC OUT
C	COM	Ground, T1	GND
G	G	G TSTAT Input	SW 24VAC IN
W1	W1	W1 Tstat Input	SW 24VAC IN
W2	W2	W2 Tstat Input	SW 24VAC IN
Y1	Y1	Y1 Tstat Input	SW 24VAC IN
Y2	Y2	Y2 Tstat Input	SW 24VAC IN
OCP	OCP	Occupancy Sensor	SW 24VAC IN
GL0	GL0	Global Input	SW 24VAC IN
D01	D01	Service Relay	24VAC OUT



Table 16. J298 (Analog Sensors)

P298	LABEL	SIGNAL DESCRIPTION	SIGNAL TYPE
R	T1	24 VAC Power	24VAC OUT
C	GND	Ground	GND
AI1	A63-IAQ	ID Air Quality Sens	0-10VDC IN
GND	GND	Digital Ground	GND
HUM	A91-RH_SENS	Humidity Sensor	0-10VDC IN
GND	GND	Ground	GND
TMP	A2-ROOM_SENS	Room/Zone Temp Sens	THERM 3.3VDC
AI2	SPARE_AIN	Not Used	0-10VDC IN
C	GND	Digital Ground	GND
R	T1	24VAC Power	24VAC OUT

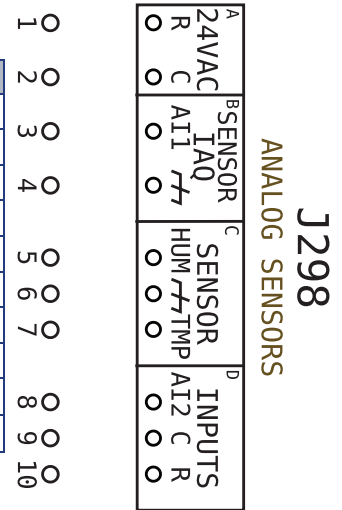

Table 17. J378 (Duct Sensors)

P378	LABEL	SIGNAL DESCRIPTION	SIGNAL TYPE
3	GND	Ground	GND
2	T1	24VAC Power	24VAC Power
1	A30	Static Duct Press Sensor	0-10VDC IN

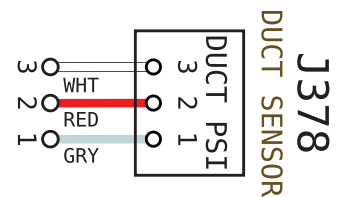
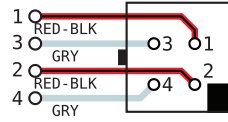

Table 18. J379 (Ultra Condenser)

P379 CAV#	LABEL	SIGNAL DESCRIPTION	SIGNAL TYPE
1	RT44	Comp 1 Liquid Temp Sens	THERM 3.3VDC
3	GND	Ground, RT44	GND
2	RT45	Comp 2 Liquid Temp Sens	THERM 3.3VDC
4	GND	Ground, RT45	GND



J379 ULTRA CONDENSER

Table 19. J380 (Smart Air)

P380 CAV#	LABEL	SIGNAL DESCRIPTION	SIGNAL TYPE
1	5VDC	5VDC Supply	5VDC OUT
2		Damper Pressure Sensor	0-5VDC IN
3	GND	Ground, Damper PSI	GND

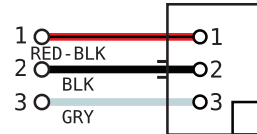

J380
SMART AIR

Table 20. J381 (Indoor Blower and Outdoor Fan Variable Speed)

P381 CAV#	LABEL	SIGNAL DESCRIPTION	SIGNAL TYPE
1	IDB	ID Blower ECM PWM1	PWM OUT 0-15V
6	GND	Ground, IDB	GND
2	IDB RPM	ID Blower RPM Feedback	PWM IN 0-5V
7	GND	Ground, IDB RPM	GND
3	BLWR_V0	VFD Blower Volt Out 0-10V	0-10VDC OUT
8	GND	Ground, BLWR_V0	GND
4	ODF1	Outdoor Fan PWM2	PWM OUT 0-18V
9	GND	Ground, ODF1	GND
5	ODF2	Outdoor Fan PWM3	PWM OUT 0-18V
10	GND	Ground, ODF2	GND

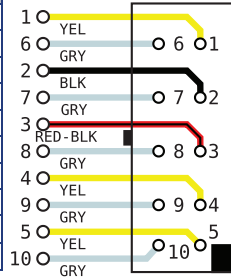

J381
ID BLOWER & OD FAN VAR SPD

Table 21. J382 (All Evaporators)

P382 CAV#	LABEL	SIGNAL DESCRIPTION	SIGNAL TYPE
1	RT6-DAT	Discharge Air Temp Sensor	THERM 3.3VDC
4	GND	Ground, DAT RT6	GND
2	RT46	Comp 1 Sat Suct Temp Sensor	THERM 3.3VDC
5	GND	Ground, RT46	GND
3	RT47	Comp 2 Sat Suct Temp Sensor	THERM 3.3VDC
6	GND	Ground, RT47	GND

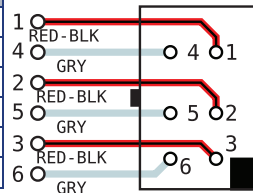

J382
ALL EVAPORATOR

Table 22. J383 (Ultra Evaporators)

P383 CAV#	LABEL	SIGNAL DESCRIPTION	SIGNAL TYPE
1	RT42	Comp 1 Suct Temp Sensor	THERM 3.3VDC
3	GND	Ground, RT42	GND
2	RT43	Comp 2 Suct Temp Sensor	THERM 3.3VDC
4	GND	Ground, RT43	GND

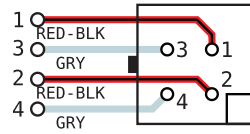

J383
ULTRA EVAPORATOR

Table 23. J384 (Economizer)

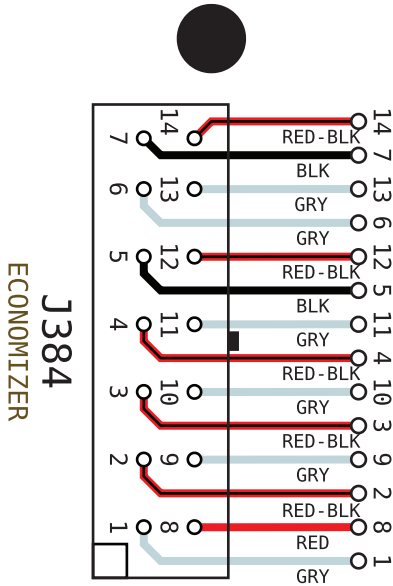

P384 CAV#	LABEL	SIGNAL DESCRIPTION	SIGNAL TYPE
14	18V	18VDC ID Enthalpy	18VDC
7	A62	ID Enthalpy Sensor	4-20mA IN
13	GND	Ground	GND
6	GND	Ground	GND
12	18V	18VDC OD Enthalpy	18VDC
5	A7	OD Enthalpy Sensor	4-20mA IN
11	GND	Ground, RAT	GND
4	RT16-RAT	RA Temp Sensor	THERM 3.3VDC
10	GND	Ground, DPOS	GND
3	DPOS	Econo, Act Pos Feedback	0-10VDC IN
9	GND	Ground, VOT	GND
2	VOT	Econo, Act Position	0-10VDC OUT
8	T1	24 VAC Power	24VAC OUT
1	GND	Ground	GND

J384
ECONOMIZER

Table 24. J385 (All Condensers)

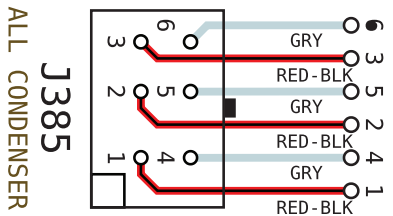

P385 CAV#	LABEL	SIGNAL DESCRIPTION	SIGNAL TYPE
6	GND	Ground, RT49	GND
3	RT49	Comp 2 Sat Liq Temp Sens	THERM 3.3VDC
5	GND	Ground, RT48	GND
2	RT48	Comp 1 Sat Liq Temp Sens	THERM 3.3VDC
4	GND	Ground, RT17	GND
1	RT17	OD Air Temp Sensor	THERM 3.3VDC

J385
ALL CONDENSER

Table 25. J386 (Refrigerant Loss Detection)

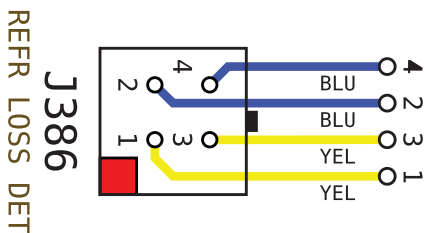

P386 CAV#	LABEL	SIGNAL DESCRIPTION	SIGNAL TYPE
4			
2			
3			
1			

J386
REFR LOSS DET

Table 26. J387 (Options)

J387
OPTIONS

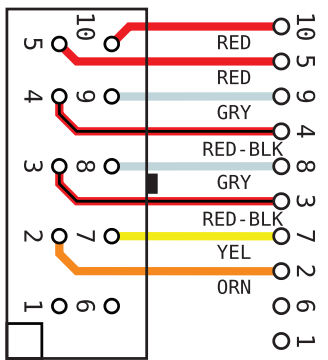

P387 CAV#	LABEL	SIGNAL DESCRIPTION	SIGNAL TYPE
10	T1	24 VAC Pwr, Overfl Sw	24VAC OUT
5	OVERFLOW	Overflow Switch	SW 24VAC
9	GND	Ground, Dirty Fltr Sw	GND
4	S27	Dirty Filter Switch	SW 5VDC
8	GND	Ground, Air Flow Sw	GND
3	S52	Air Flow Switch	SW 5VDC
7	GND	Ground, Ionizer BAS	GND
2	ION	Ionizer BAS	5VDC
6	GND	Ground, SPARE_1	GND
1	SPARE_1	Spare1	SW 5VDC

Table 27. J388 (Pressure Switches)

J388
PRESSURE SWITCHES
COLORS ARE FOR
A- & B-BOX ONLY

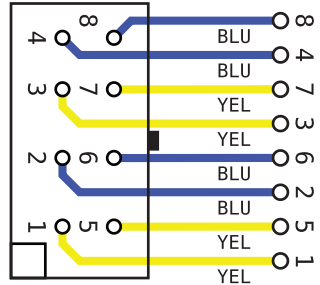

P388 CAV#	LABEL	SIGNAL DESCRIPTION	SW 24VAC
8	T1	24 VAC Power, LPSW2	24VAC OUT
4	S88-LPSW2	Low Press Sw Comp 2	SW 24VAC
7	T1	24 VAC Power, LPSW1	24VAC OUT
3	S87-LPSW1	Low Pres Sw Comp 1	SW 24VAC
6	T1	24 VAC Power, HPSW2	24VAC OUT
2	S7-HPSW2	High Press Sw Comp 2	SW 24VAC
5	T1	24 VAC Power, HPSW1	24VAC OUT
1	S4-HPSW1	High Press Sw Comp 1	SW 24VAC

Table 28. J389 (Compressors 1 and 2)

J389
COMPRESSOR 1,2
COLORS ARE FOR
A- & B-BOX ONLY

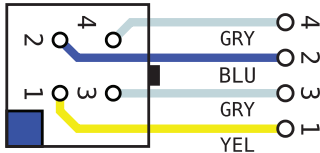

P389 CAV#	LABEL	SIGNAL DESCRIPTION	SIGNAL TYPE
4	GND	Ground, COMP2	GND
2	COMP2	Compressor 2	24VAC OUT
3	GND	Ground, COMP1	GND
1	COMP1	Compressor 1	24VAC OUT

Table 29. J390 (Relays)

COMPRESSOR 1,2
COLORS ARE FOR
RELAYS

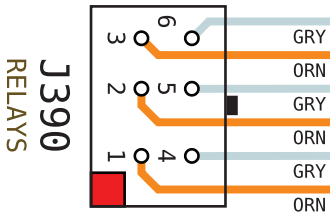

P390 CAV#	LABEL	SIGNAL DESCRIPTION	SIGNAL TYPE
6	GND	Ground, K65	GND
3	K65	Power Exhaust Stage 1	24VAC OUT
5	GND	Ground, K68	GND
2	K68	Outdoor Fan 2	24VAC OUT
4	GND	Ground, K10	GND
1	K10	Outdoor Fan 1	24VAC OUT

Table 30. J391 (Compressor 2-Stage)

COMPR 2-STG
J391

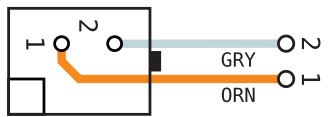

P391 CAV#	LABEL	SIGNAL DESCRIPTION	SIGNAL TYPE
2	GND	Ground, L34	GND
1	L34	Comp 1 stage 2 solenoid	24VAC OUT

Table 31. J392 (Blower)

SEE ALSO OPTIONAL
IONIZER CONNECTION
FOR C-BOX W/O BLWR
INVERTER BYPASS ONLY

BLOWER
J392

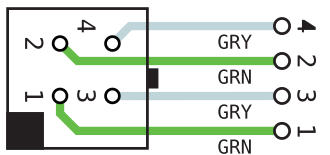

P392 CAV#	LABEL	SIGNAL DESCRIPTION	SIGNAL TYPE
4	GND	Ground, VFD Bypass	GND
2	BYPS	VFD Bypass	24VAC OUT
3	GND	Ground, Blower	GND
1	BLWR	Blower	24VAC OUT

Table 32. J393 (Gas Heat)

HEAT
J393-GAS-HEAT

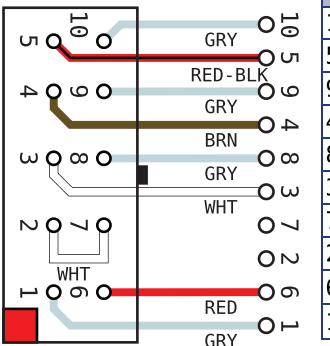

P393 CAV#	LABEL	SIGNAL DESCRIPTION	SIGNAL TYPE
10	GND	Ground, MGV	GND
5	MGV	Modul Gas Valve 0-10V	0-10VDC OUT
9	GND	Ground, HEAT2	GND
4	HEAT2-K16	Heat 2, Elec Heat 2	24VAC OUT
8	GND	Ground, HEAT1	GND
3	HEAT1-K15	Heat 1, Elec Heat 1	24VAC OUT
7	EH_LIMIT	Elec Ht Limit Sw Return	SW 24VAC OUT
2	EH_LIMIT	Elec Ht Limit Sw	24VAC OUT
6	T18	24 VAC Power	24VAC OUT
1	GND	Ground	GND

Table 33. J393 (Electric Heat)

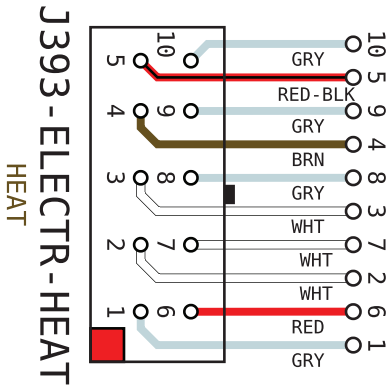

P393 CAV#	LABEL	SIGNAL DESCRIPTION	SIGNAL TYPE
10	GND	Ground, MGV	GND
5	MGV	Modul Gas Valve 0-10V	0-10VDC OUT
9	GND	Ground, HEAT2	GND
4	HEAT2-K16	Heat 2, Elec Heat 2	24VAC OUT
8	GND	Ground, HEAT1	GND
3	HEAT1-K15	Heat 1, Elec Heat 1	24VAC OUT
7	EH LIMIT	Elec Ht Limit Sw Return	SW 24VAC OUT
2	EH LIMIT	Elec Ht Limit Sw	24VAC OUT
6	T18	24 VAC Power	24VAC OUT
1	GND	Ground	GND

Table 34. J394 (ReHeat)

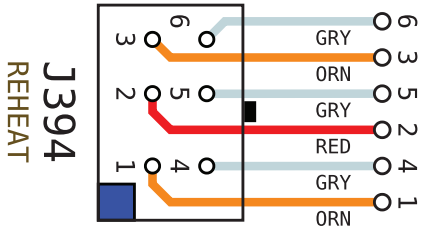

P394 CAV#	LABEL	SIGNAL DESCRIPTION	SIGNAL TYPE
6	GND	Ground, REHEAT2	GND
3	L30	Humiditrol (Reheat) 2	24VAC OUT
5	GND	Ground, T43	GND
2	T43	24 VAC Power	24VAC IN
4	GND	Ground, REHEAT1	GND
1	L14	Humiditrol (Reheat) 1	24VAC OUT

Table 35. J388 (C Box)

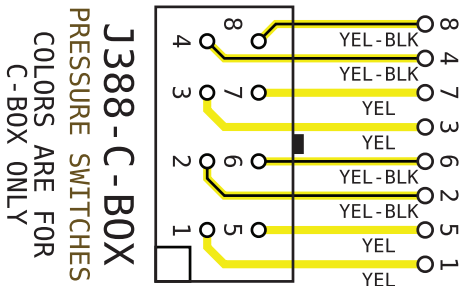

P388 CAV#	LABEL	SIGNAL DESCRIPTION	SW 24VAC
8	T1	24 VAC Power, LPSW2	24VAC OUT
4	S88-LPSW2	Low Press Sw Comp 2	SW 24VAC
7	T1	24 VAC Power, LPSW1	24VAC OUT
3	S87-LPSW1	Low Pres Sw Comp 1	SW 24VAC
6	T1	24 VAC Power, HPSW2	24VAC OUT
2	S7-HPSW2	High Press Sw Comp 2	SW 24VAC
5	T1	24 VAC Power, HPSW1	24VAC OUT
1	S4-HPSW1	High Press Sw Comp 1	SW 24VAC

Table 36. J389 (C Box)

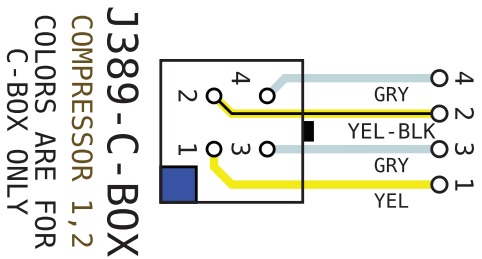

P389 CAV#	LABEL	SIGNAL DESCRIPTION	SIGNAL TYPE
4	GND	Ground, COMP2	GND
2	COMP2	Compressor 2	24VAC OUT
3	GND	Ground, COMP1	GND
1	COMP1	Compressor 1	24VAC OUT

Table 37. J395 (Power In)

J395
POWER IN



P395 CAV#	LABEL	SIGNAL DESCRIPTION	SIGNAL TYPE
4	GND	Transformer T18, 24VAC return	GND
3	T18	Transformer T18, 24VAC	24VAC IN
2	GND	Transformer T1, 24VAC return	GND
1	T1	Transformer T1, 24VAC	24VAC IN

Table 38. J358 (MODBUS Vs COMPR)

J358
MODBUS
VS COMPR

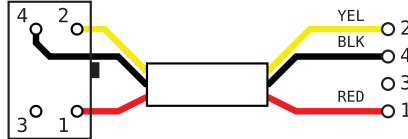

P395 CAV#	LABEL	SIGNAL DESCRIPTION	SIGNAL TYPE
2	B	RS485, B (-) inverting	0-5VDC
4	G	Ground, Current limited	GND
3		Not Used	
1	A	RS485, A (+) non-inverting	0-5VDC

Table 39. J413 (Modbus)

P413	LABEL	SIGNAL DESCRIPTION	SIGNAL TYPE
1	A	RS485, A(+) non-inverting	0-5VDC
2	G	Ground, Current Limiting	DRAINWIRE
3	B	RS485, B(-) inverting	0-5VDC

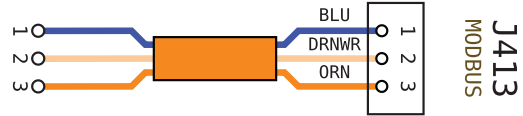

16.2. C4 Control (A178)

Table 40. P396 (Electric Heat)

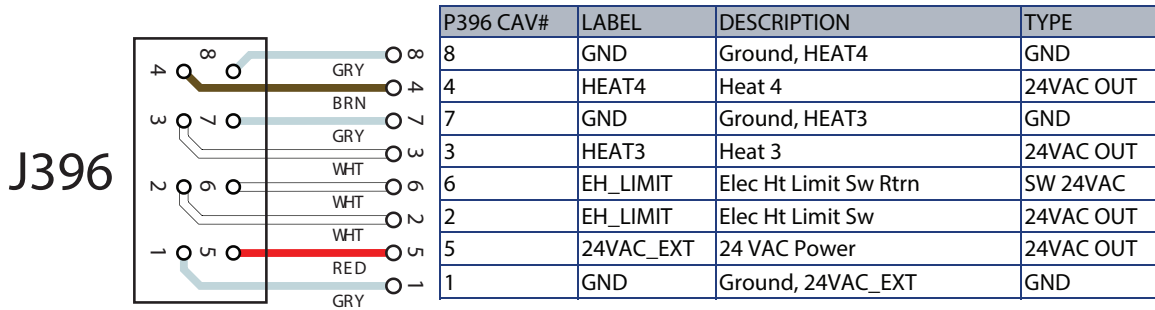

Table 41. P396 (Gas Heat)

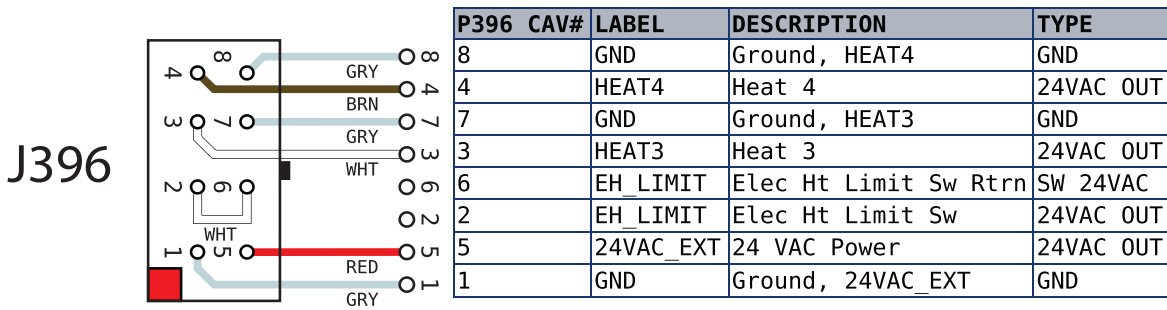

Table 42. P397 (Compressor Fans)

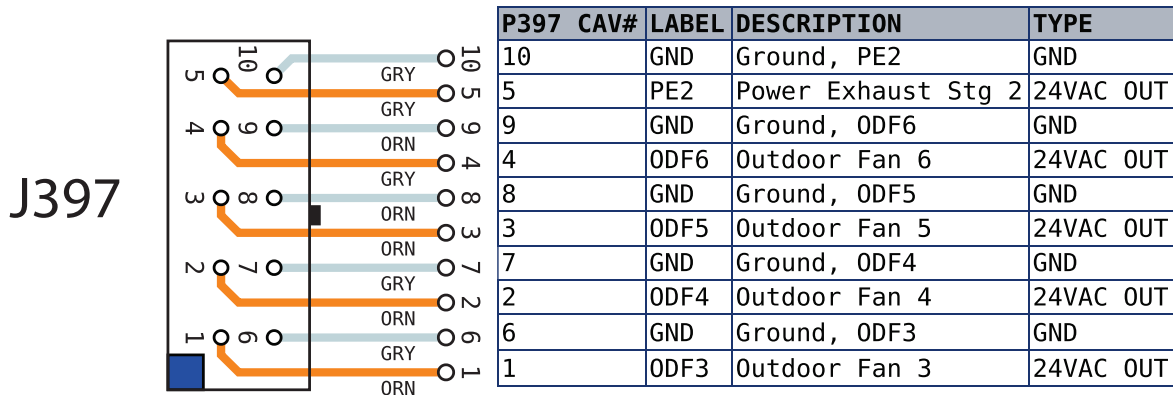

Table 43. P398 (Compressors 3 and 4)

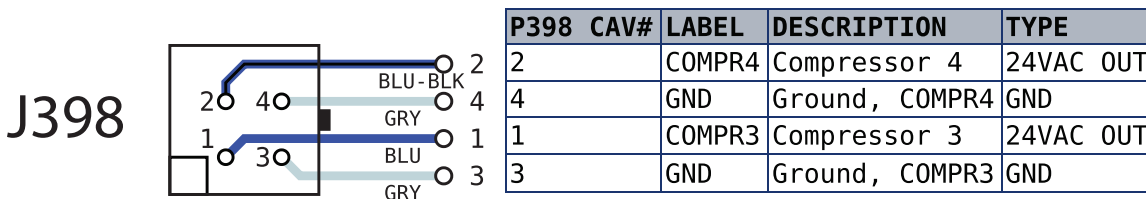
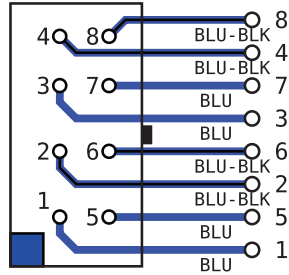

Table 44. P399 (Pressure Switches 3 and 4)

J399



P399 CAV#	LABEL	DESCRIPTION	TYPE
8	24VAC_EXT	24 VAC Power, HPSW4	24VAC OUT
4	S96-HPSW4	High Press Sw Comp 4	SW 24VAC
7	24VAC_EXT	24 VAC Power, HPSW3	24VAC OUT
3	S28-HPSW3	High Press Sw Comp 3	SW 24VAC
6	24VAC_EXT	24 VAC Power, LPSW4	24VAC OUT
2	S97-LPSW4	Low Press Sw Comp 4	SW 24VAC
5	24VAC_EXT	24 VAC Power, LPSW3	24VAC OUT
1	S98-LPSW3	Low Press Sw Comp 3	SW 24VAC

Table 45. P400 (24VAC)

J400



P400 CAV#	LABEL	DESCRIPTION	TYPE
1	24VAC IN	External 24VAC Power	24VAC IN
2	GND	Ground, 24VAC Power Return	GND

Table 46. P401 (All Evaporators)

J401

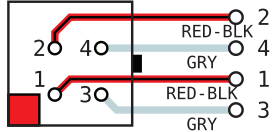

P401 CAV#	LABEL	DESCRIPTION	TYPE
2	RT51	Comp 4 Sat Suct Temp Sensor	THERM 3.3VDC
4	GND	Ground, RT51	GND
1	RT50	Comp 3 Sat Suct Temp Sensor	THERM 3.3VDC
3	GND	Ground, RT50	GND

Table 47. P402 (Ultra Evaporators)

J402



P402 CAV#	LABEL	DESCRIPTION	TYPE
4	GND	Ground, RT55	GND
3	RT55	Comp 4 Suct Temp Sensor	THERM 3.3VDC
2	GND	Ground, RT54	GND
1	RT54	Comp 3 Suct Temp Sensor	THERM 3.3VDC

Table 48. P403 (Options)

J403

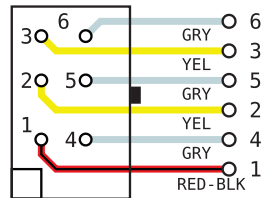

P403 CAV#	LABEL	DESCRIPTION	TYPE
6	GND	Ground, ODF3	GND
3	ODF3	Outdoor Fan PWM4	PWM OUT 0-18V
5	GND	Ground, ODF4	GND
2	ODF4	Outdoor Fan PWM5	PWM OUT 0-18V
4	GND	Ground, PE_VFD	Ground, PE_VFD
1	PE_VFD	Power Exhaust VFD Control	0-10VDC OUT

Table 49. P404 (All Condensers)

J404

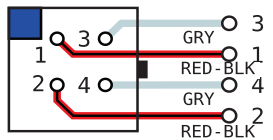

P404 CAV#	LABEL	DESCRIPTION	TYPE
3	GND	Ground, RT52	GND
1	RT52	Comp 3 Sat Liq Temp Sens	THERM 3.3VDC
4	GND	Ground, RT53	GND
2	RT53	Comp 4 Sat Liq Temp Sens	THERM 3.3VDC

Table 50. P404 (Ultra Condensers)

J405		<table border="1"> <thead> <tr> <th>P405 CAV#</th> <th>LABEL</th> <th>DESCRIPTION</th> <th>TYPE</th> </tr> </thead> <tbody> <tr> <td>1</td> <td>RT56</td> <td>Comp 3 Liq Temp Sens</td> <td>THERM 3.3VDC</td> </tr> <tr> <td>2</td> <td>GND</td> <td>Ground, RT56</td> <td>GND</td> </tr> <tr> <td>3</td> <td>RT57</td> <td>Comp 4 Liq Temp Sens</td> <td>THERM 3.3VDC</td> </tr> <tr> <td>4</td> <td>GND</td> <td>Ground, RT57</td> <td>GND</td> </tr> </tbody> </table>	P405 CAV#	LABEL	DESCRIPTION	TYPE	1	RT56	Comp 3 Liq Temp Sens	THERM 3.3VDC	2	GND	Ground, RT56	GND	3	RT57	Comp 4 Liq Temp Sens	THERM 3.3VDC	4	GND	Ground, RT57	GND
	P405 CAV#	LABEL	DESCRIPTION	TYPE																		
	1	RT56	Comp 3 Liq Temp Sens	THERM 3.3VDC																		
	2	GND	Ground, RT56	GND																		
3	RT57	Comp 4 Liq Temp Sens	THERM 3.3VDC																			
4	GND	Ground, RT57	GND																			

Table 51. P396 (Electric Heat)

J396		<table border="1"> <thead> <tr> <th>P396 CAV#</th> <th>LABEL</th> <th>DESCRIPTION</th> <th>TYPE</th> </tr> </thead> <tbody> <tr> <td>8</td> <td>GND</td> <td>Ground, HEAT4</td> <td>GND</td> </tr> <tr> <td>4</td> <td>HEAT4</td> <td>Heat 4</td> <td>24VAC OUT</td> </tr> <tr> <td>7</td> <td>GND</td> <td>Ground, HEAT3</td> <td>GND</td> </tr> <tr> <td>3</td> <td>HEAT3</td> <td>Heat 3</td> <td>24VAC OUT</td> </tr> <tr> <td>6</td> <td>EH_LIMIT</td> <td>Elec Ht Limit Sw Rtrn</td> <td>SW 24VAC</td> </tr> <tr> <td>2</td> <td>EH_LIMIT</td> <td>Elec Ht Limit Sw</td> <td>24VAC OUT</td> </tr> <tr> <td>5</td> <td>24VAC_EXT</td> <td>24 VAC Power</td> <td>24VAC OUT</td> </tr> <tr> <td>1</td> <td>GND</td> <td>Ground, 24VAC_EXT</td> <td>GND</td> </tr> </tbody> </table>	P396 CAV#	LABEL	DESCRIPTION	TYPE	8	GND	Ground, HEAT4	GND	4	HEAT4	Heat 4	24VAC OUT	7	GND	Ground, HEAT3	GND	3	HEAT3	Heat 3	24VAC OUT	6	EH_LIMIT	Elec Ht Limit Sw Rtrn	SW 24VAC	2	EH_LIMIT	Elec Ht Limit Sw	24VAC OUT	5	24VAC_EXT	24 VAC Power	24VAC OUT	1	GND	Ground, 24VAC_EXT	GND
	P396 CAV#	LABEL	DESCRIPTION	TYPE																																		
	8	GND	Ground, HEAT4	GND																																		
	4	HEAT4	Heat 4	24VAC OUT																																		
	7	GND	Ground, HEAT3	GND																																		
	3	HEAT3	Heat 3	24VAC OUT																																		
	6	EH_LIMIT	Elec Ht Limit Sw Rtrn	SW 24VAC																																		
	2	EH_LIMIT	Elec Ht Limit Sw	24VAC OUT																																		
5	24VAC_EXT	24 VAC Power	24VAC OUT																																			
1	GND	Ground, 24VAC_EXT	GND																																			

Table 52. C4 Control Jacks and Plug Part Numbers

TE VAL-U-LOK BOARD HEADERS & CONNECTING PLUG HOUSINGS

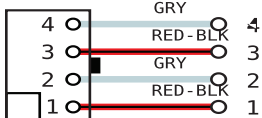
# CIRCUITS	BOARD HEADER DESIGNATION	BOARD HEADER OEM PART # (TE)	CONNECTING PLUG DESIGNATION	LENNOX PART #	CONNECTING PLUG OEM PART # (TE)	COLOR
8	J396	2029138-8	P396	106509-04	2029094-8	RED
10	J397	1-2029142-0	P397	106510-05	1-2029100-0	BLUE
4	J398	1586040-4	P398	106507-02	1969614-4	WHITE
8	J399	2029142-8	P399	106510-04	2029100-8	BLUE
2	J400	2029134-2	P400	106508-01	2029029-2	BLACK
4	J401	2029138-4	P401	106509-02	2029094-4	RED
4	J402	TBD	P402	106504-03	2029208-4	BLACK
6	J403	1586040-6	P403	106507-03	1969614-6	WHITE
4	J404	2029142-4	P404	106510-02	2029100-4	BLUE
4	J405	2029056-4	P405	106504-02	1586027-4	WHITE

TE VAL-U-LOK TERMINAL PART # 794956-1 (Strip Form), Brass/Pre-Tin, 18-22AWG - Lennox Part # 106505-01

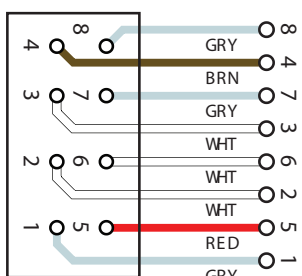
16.3. DSI Board (A3)

Table 53. J406 (A3) (M4 Control)

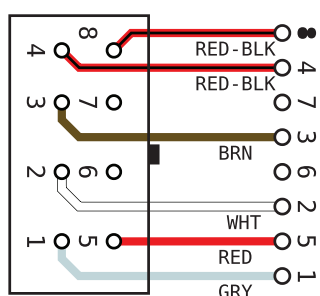
J406		<table border="1"> <thead> <tr> <th>P406 CAV#</th> <th>LABEL</th> <th>DESCRIPTION</th> </tr> </thead> <tbody> <tr> <td>8</td> <td>MGV2</td> <td>Modulating Gas Valve feedback</td> </tr> <tr> <td>4</td> <td>MGV1</td> <td>0-10VDC Modulating Gas Valve</td> </tr> <tr> <td>7</td> <td></td> <td></td> </tr> <tr> <td>3</td> <td>W2</td> <td>24VAC DIGITAL ON/OFF</td> </tr> <tr> <td>6</td> <td></td> <td></td> </tr> <tr> <td>2</td> <td>W1</td> <td>24VAC DIGITAL ON/OFF</td> </tr> <tr> <td>5</td> <td>R1</td> <td>24VAC Supply</td> </tr> <tr> <td>1</td> <td>C</td> <td>24VAC COM</td> </tr> </tbody> </table>	P406 CAV#	LABEL	DESCRIPTION	8	MGV2	Modulating Gas Valve feedback	4	MGV1	0-10VDC Modulating Gas Valve	7			3	W2	24VAC DIGITAL ON/OFF	6			2	W1	24VAC DIGITAL ON/OFF	5	R1	24VAC Supply	1	C	24VAC COM
	P406 CAV#	LABEL	DESCRIPTION																										
	8	MGV2	Modulating Gas Valve feedback																										
	4	MGV1	0-10VDC Modulating Gas Valve																										
	7																												
	3	W2	24VAC DIGITAL ON/OFF																										
	6																												
	2	W1	24VAC DIGITAL ON/OFF																										
5	R1	24VAC Supply																											
1	C	24VAC COM																											

A3

Table 54. J406 (A12) (M4 Control)

A12

J406

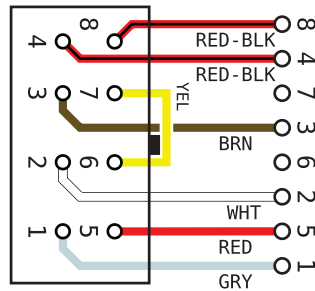

P406 CAV#	LABEL	DESCRIPTION
8	MGV2	Modulating Gas Valve feedback
4	MGV1	0-10VDC Modulating Gas Valve
7	D1	24VAC DIGITAL ON/OFF
3	W2	24VAC DIGITAL ON/OFF
6	R2	24 VAC Supply
2	W1	24VAC DIGITAL ON/OFF
5	R1	24VAC Supply
1	C	24VAC COM

Table 55. J374 (Versions 1 through 4)

J374-VER-1
1-SPD PSC CAI MOTOR

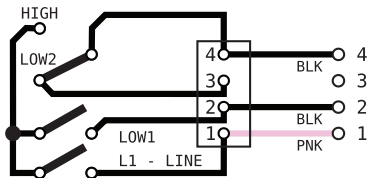

P374 CAV#	LABEL	DESCRIPTION
4	HIGH	208/230/460 VAC
3		
2	LOW 1	208/230/460 VAC
1	L1-LINE	208/230/460 VAC ALWAYS ON

1-SPEED PSC
104532
A-Box

J374-VER-2
1-SPD PSC CAI MOTOR

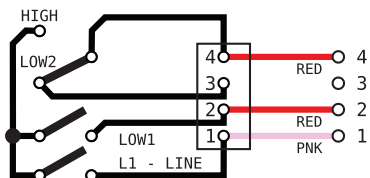

P374 CAV#	LABEL	DESCRIPTION
4	HIGH	208/230/460 VAC
3		
2	LOW 1	208/230/460 VAC
1	L1-LINE	208/230/460 VAC ALWAYS ON

1-SPEED PSC
104409
B-Box
C-Box
D-Box

J374-VER-3
3-SPD ECM CAI MOTOR

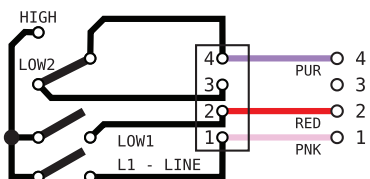

P374 CAV#	LABEL	DESCRIPTION
4	HIGH	208/230/460 VAC
3		
2	LOW 1	208/230/460 VAC
1	L1-LINE	208/230/460 VAC ALWAYS ON

3-SPEED ECM
105035

J374-VER-4
2-SPD PSC CAI MOTOR

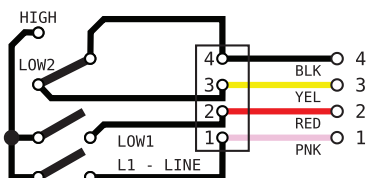

P374 CAV#	LABEL	DESCRIPTION
4	HIGH	208/230/460 VAC
3	LOW 2	208/230/460 VAC
2	LOW 1	208/230/460 VAC
1	L1-LINE	208/230/460 VAC ALWAYS ON

2-SPEED PSC
105223

Table 56. J10 (GV1) (S18)

**J10
(S18)**

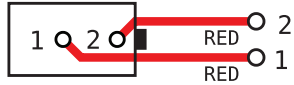

P410	CAV#	LABEL	DESCRIPTION
2		S18, S45 OUT	24VAC DIGITAL ON/OFF
1		S18, S45 IN	24VAC

Table 57. J408 (GV1) (S47)

J408

P408	CAV#	LABEL	DESCRIPTION
4		GV-M	24VAC, 3AMP INRUSH FOR 16mS
1		GV-C	24VAC, 3AMP INRUSH FOR 16mS
5		OPEN	OPEN
2		GV-H	24VAC, 3AMP INRUSH FOR 16mS
6		S47, S69	Flame Rollout, 24VAC DIGITAL ON/OFF
3		S47, S69	Flame Rollout, 24VAC DIGITAL ON/OFF

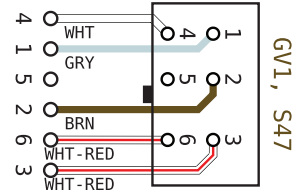
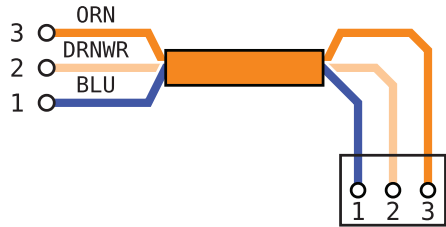

Table 58. J412 (MODUS 2)

P412	CAV#	LABEL	DESCRIPTION
3		B	0-5VDC MODBUS
2		G	DRAINWIRE
1		A	0-5VDC MODBUS



**J412
MODBUS 2**

Table 59. J411 (MODUS 1)

P411	CAV#	LABEL	DESCRIPTION
3		B	0-5VDC MODBUS
2		G	DRAINWIRE
1		A	0-5VDC MODBUS

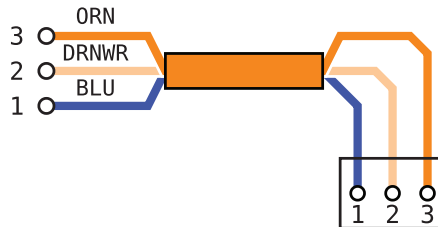

**J411
MODBUS 1**

Table 60. J407 (S10 and S21)

P407 CAV#	LABEL	DESCRIPTION
1	S10, S99	24VAC
2	S10, S99	24VAC DIGITAL ON/OFF
3	S21, S100	24VAC DIGITAL ON/OFF
4	S21, S100	24VAC DIGITAL ON/OFF

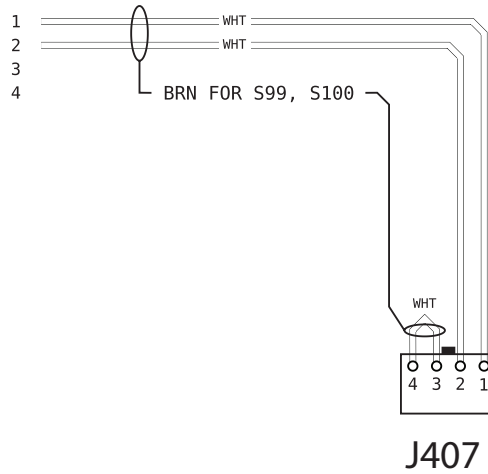

Table 61. DSI Control Jacks and Plugs Part Numbers

BOARD HEADERS & CONNECTING PLUG HOUSINGS

#	CIRCUITS	BOARD HEADER	BOARD HEADER OEM PART #	CONNECTING PLUG	LENNOX PART #	CONNECTING PLUG OEM PART #	COLOR	TERMINAL PART #
4	J374	TE	350793-1	P374	31K2101	TE 770019-1	NATURAL	31K3401
8	J406	TE	1586040-8	P406	106507-04	TE 1969614-8	WHITE	106505-01
4	J407	TE	2029056-4	P407	106504-02	TE 1586027-4	WHITE	106505-01
6	J408	TE	1586040-6	P408	106507-03	TE 1969614-6	WHITE	106505-01
4	J409	TE	1586040-4	P409	106507-02	TE 1969614-4	WHITE	106505-01
2	J410	TE	1586040-2	P410	106507-01	TE 1969614-2	WHITE	106505-01
3	J411	STOCKO	MSLO 9407-003-03R-960-000-00	P411	102201-04	EH 688-003-04V-960-A	NATURAL	102198-01
3	J412	STOCKO	MSLO 9407-003-03R-960-000-00	P412	102201-04	EH 688-003-04V-960-A	NATURAL	102198-01
1	FS	NOT APPLICABLE	(3/16 TAB)	FS	N/A	TE 42452-2	TIN	P-8-6995

16.4. W4 Control

Table 62. W4 Control

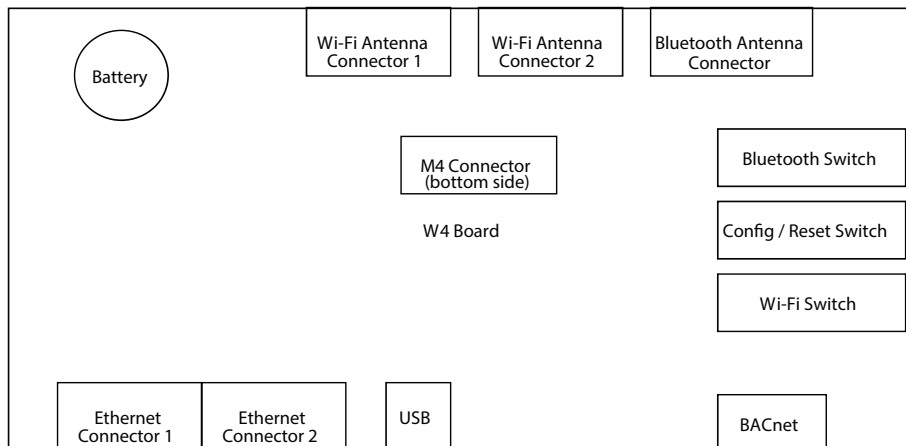

17. Quick Start Guide

CAUTION

Check rooftop unit electrical power for proper voltage and phasing. Check gas train components.

- a. Turn on unit and dismiss alarm messages as necessary.
- b. Follow SETUP > INSTALL menu to properly configure unit
- c. Be sure unit is in normal operating mode as seen in display (COOLING, HEATING, IDLE, etc).
- d. To verify operation use SERVICE > TEST menu.

Control Mode	Menu Setup Needed	Tips
THERMOSTAT	(Factory set for 2-stage thermostat)	Check LEDs for signals.
BACnet	SETUP > NETWORK INTEGRATION > NETWORK WIZARD > NETWORK TYPE = BACNET MS/TP	<ul style="list-style-type: none"> • Setup information to be verified with integrator. • Follow wiring instructions including network termination • Remember to set MAC address 0-127 • Expert level BACnet service manual available.
LonTalk	SETUP > NETWORK INTEGRATION > NETWORK WIZARD > = LONTALK	<ul style="list-style-type: none"> • Setup information to be verified with integrator. • Follow wiring instructions including network termination • XIF file available. Neuron ID on sticker. • Expert level LonTalk service manual available.
Damper	SETUP > TEST & BALANCE > DAMPER	<ul style="list-style-type: none"> • Verify damper minimum positions • Refer to Economizer section of manual for more detail
Local Mode	SETUP > NETWORK INTEGRATION > NETWORK WIZARD > RTU STANDALONE	<ul style="list-style-type: none"> • Give unit time to start-up. • Humidity control requires sensor or error code 7649
Dehumidifier	Dehumidifier setup will be done during the SETUP >INSTALL wizard. It's the last part of that wizard.	<ul style="list-style-type: none"> • Three possible connections, LOCAL SENSOR, NETWORK SENSOR and REHEAT DI4. • Analog sensor wiring is polarity sensitive
Blower	Change motor torque; see SETUP > TEST & BALANCE > BLOWER	<ul style="list-style-type: none"> • Final motor CFM should be set by Test and Balance technician • Blower charts are located in the unit installation instruction.

18. Wiring Diagrams

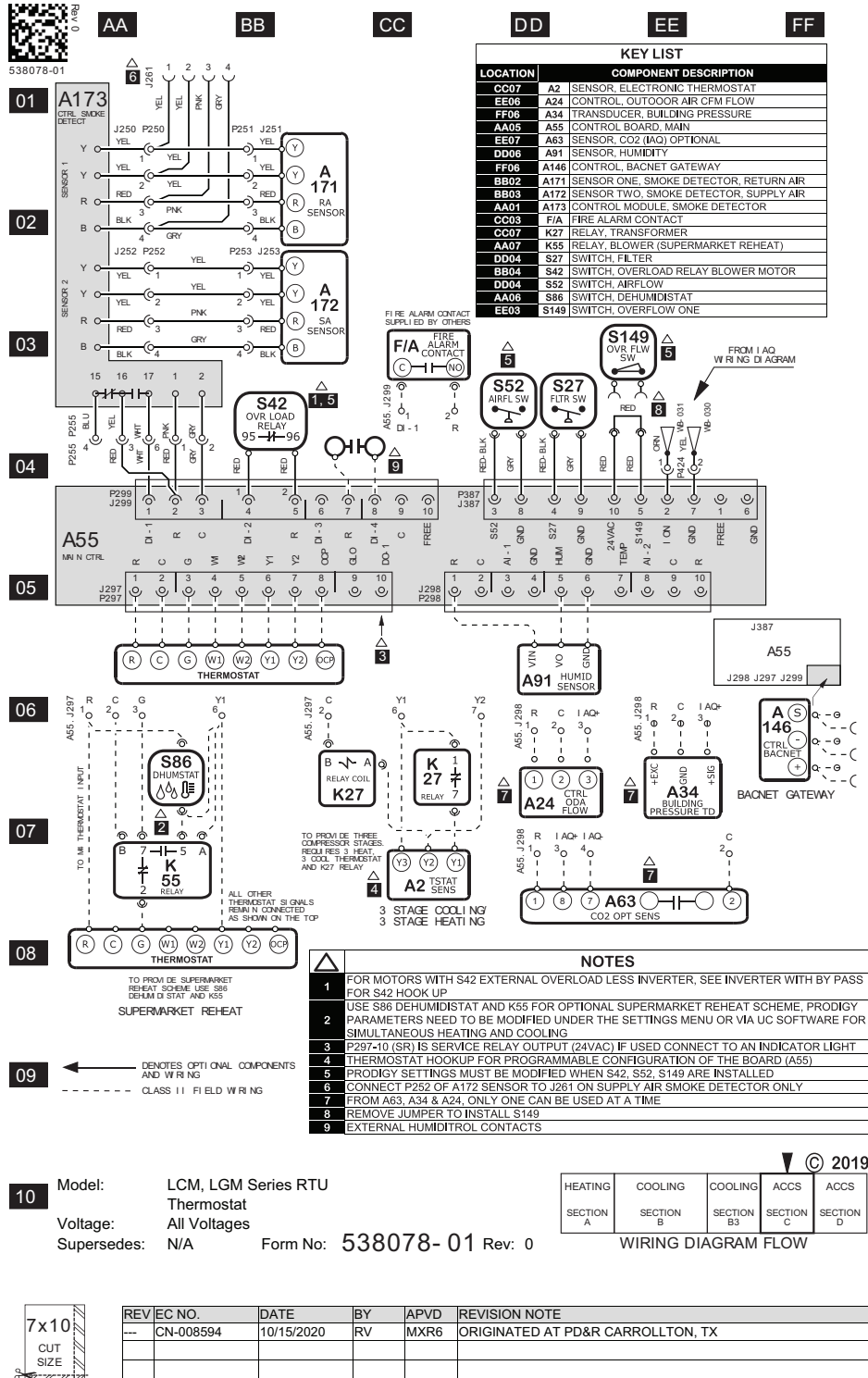

Figure 38. Wiring Diagram - Part 1

Index

A

Abbreviations 37, 38
Alarms 40

B

Blower Operation with Effective Occupancy 30

C

Connections 4, 7

D

Damper Operation During Free Cooling 32
Demand Control Ventilation 35

E

Economizer Checkout 33
Enabling Economizer and Settings 32
Enthalpy Set Point 33

F

Free Cooling Compressor Lockout Mode 32
Free Cooling Damper Maximum Position 33

I

ICON Setting 75
Inputs/Outputs 4

J

Jumpers 4

L

L CONNECTION 37
LED Operation Indicators 5
LEDs 4
Low Ambient Set Point 32

M

Menu Selection Overview 9
Minimum Damper Position 33
MODBUS 4
Motorized Outdoor Air Damper 33

O

Outdoor Air Suitable for Free Cooling 33
Overview 3

P

Parts and Kits 39
Phase - Voltage Detection 40

Q

Quick Start Guide 92

S

Service Relays 40
System Status Screen 7
System Status Screen

Unit Operation 9

T

Thermal Protection Switches (S5, S7, S8, S31 and S180) 29
Thermostat / Humidistat Common Isolation 4

U

Unit Operation 9
USB Flash Drive Interface Usage 4
USB Service Report Example 39

W

Wiring Diagram 93