

LHX

XION™ ROOFTOP UNITS

Standard Efficiency | Lennox® CORE Lite Controller | **R-454B** | 60Hz



COMMERCIAL PRODUCT SPECIFICATIONS (EHB)

7.5 to 10 Tons

Net Cooling Capacity - 89,000 to 116,000 Btuh

Net Heating Capacity - 89,000 to 118,000 Btuh

Optional Electric Heat - 7.5 to 60 kW

XION

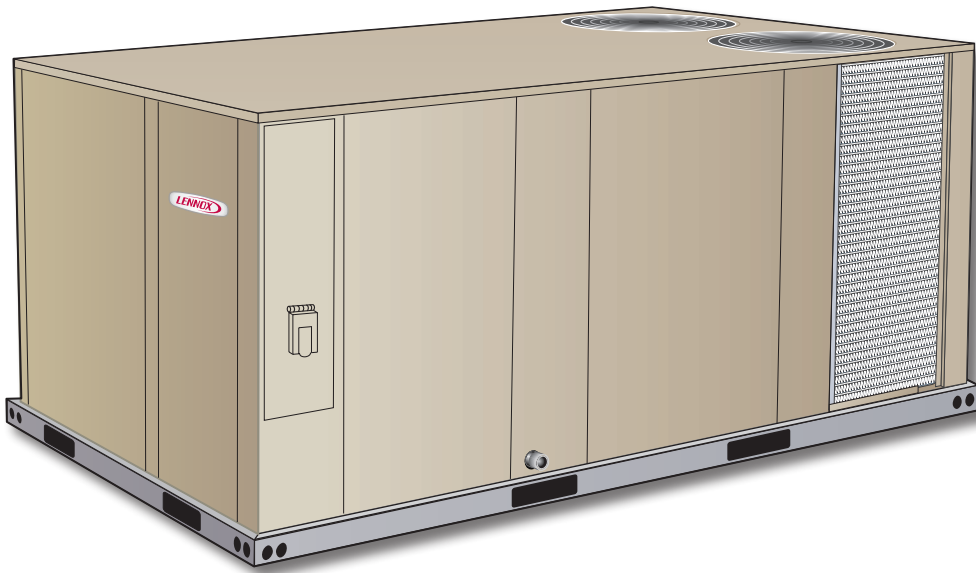

MODEL NUMBER IDENTIFICATION

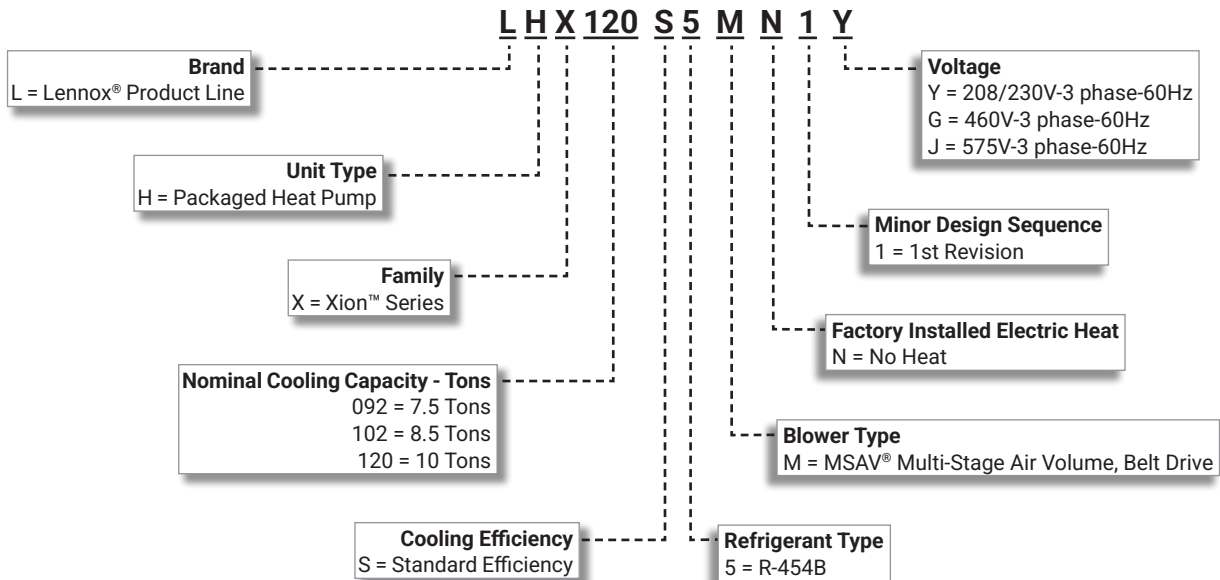

FEATURE HIGHLIGHTS

Xion™ rooftop units are engineered with the right technologies and options to meet standard efficiency requirements while delivering reliable performance and year-round comfort.

1. Scroll Compressors
2. Check/Thermal Expansion Valves
3. Reversing Valves
4. Filter/Driers
5. Copper Tube Outdoor Coil
6. Outdoor Coil Fan Motors
7. Heavy Gauge Steel Cabinet
8. Insulation
9. Hinged Access Panels (option)
10. MSAV Multi-Stage Air Volume Blower
11. Electric Heat (option)
12. Air Filters
13. Lennox® CORE Lite Control System

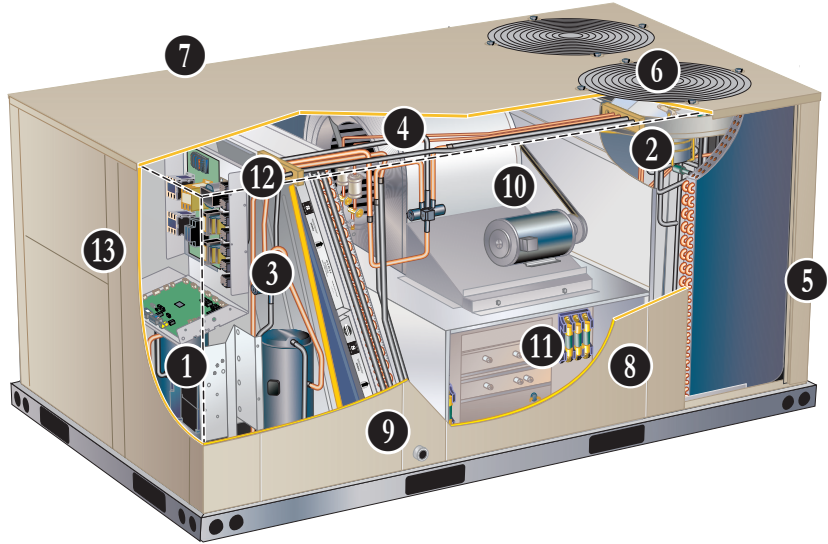

CONTENTS

Approvals And Warranty	3
Blower Data	19
- Belt Drive - 7.5 Ton	19
- Belt Drive - 8.5 10 Ton	20
Cooling/Heating Ratings	16
Dimensions	29
- Accessories	30
- Unit	29
Electrical/Electric Heat Data	23
- 7.5 Ton	23
- 8.5 Ton	24
- 10 Ton	25
Electric Heat Capacities	26
Features And Benefits	3
Model Number Identification	1
Optional Conventional Temperature Control Systems	11
Options / Accessories	12
Outdoor Sound Data	27
Specifications	15
Unit Clearances	27
Weight Data	28
- Unit	28

APPROVALS AND WARRANTY

APPROVALS

- AHRI Standard 340/360-2023 certified
- ETL and CSA listed
- Unit and components ETL, NEC and CEC bonded for grounding to meet safety standards for servicing
- All models are ASHRAE 90.1 energy efficiency compliant and meet or exceed requirements of Section 6.8
- All models meet DOE 2023 energy efficiency standards and UL 60335-2-40 Refrigerant Detector Requirements
- All models have HCAI (formerly OSHPD) OSP and Special Seismic Certification ([Number: OSP-0596](#)), and meet 2021 International Building Code (IBC), 2022 California Building Code (CBC) ASCE 7, and ICC-ES AC156
- All models meet California Code of Regulations, Title 24 and ASHRAE 90.1 Section 6.4.3.10 requirements for staged airflow
- ISO 9001 Registered Manufacturing Quality System

WARRANTY

- Compressors - Limited five years
- Lennox® CORE Lite Unit Controller - Limited three years
- Variable-Frequency Drive (VFD) - Limited five years
- High Performance Economizers (optional) - Limited five years
- All other covered components - Limited one year

FEATURES AND BENEFITS

COOLING/HEATING SYSTEM

- Designed to maximize sensible and latent cooling performance at design conditions
- System can operate in the cooling mode from 45°F to 125°F without any additional controls
- Mechanical heating operates at ambient temperatures above -15°F

R-454B Refrigerant

- Low GWP (Global Warming Potential)
- Zero ODP (Ozone Depletion Potential)
- Low Toxicity/Lower Flammability - A2L
- Unit is factory pre-charged

1 Compressor System

- System consists of one two-stage scroll compressor and one single stage scroll compressor
- Resiliently mounted on rubber grommets for quiet operation

Compressor Crankcase Heaters

- Protects against refrigerant migration that can occur during low ambient operation or during extended off cycles

2 Check/Thermal Expansion Valves

- Assures optimal performance throughout the application range

3 Reversing Valve

- 4-way interchange reversing valve effects a rapid change in direction of refrigerant flow resulting in quick changeover from cooling to heating and vice versa

4 Filter/Driers

- High capacity filter/drier protects the system from dirt and moisture

High Pressure Switches

- Protects the compressor from overload conditions
- Auto-reset

Low Pressure Switches

- Protects the compressors from low pressure conditions such as low refrigerant charge or low/no airflow

Indoor Coil Freeze Protection

- Protects the evaporator coil from damaging ice build-up due to conditions such as low/no airflow, or low refrigerant charge

5 Coil Construction

- Copper tube construction
- Enhanced rippled-edge aluminum fins
- Flared shoulder tubing connections
- Silver soldered construction
- Factory leak tested
- Two independent formed outdoor coils allow separation for cleaning
- Cross-row circuiting of indoor coil with rifled copper tubing optimizes both sensible and latent cooling capacity

Antimicrobial Condensate Drain Pan

- Composite pan, sloped to meet drainage requirements of ASHRAE 62.1
- Antimicrobial additive resists growth of mold and mildew on drain pan, which improves indoor air quality and reduces drain line blockage
- Side or bottom drain connections
- Reversible to allow connection at back of unit

6 Outdoor Coil Fan Motors

- Single speed PSC fan motor
- Thermal overload protected
- Totally enclosed
- Permanently lubricated sleeve bearings
- Shaft up
- Wire basket mount

FEATURES AND BENEFITS

COOLING / HEATING SYSTEM (continued)

Outdoor Coil Fans

- PVC coated fan guards furnished

Required Selections

Cooling Capacity

- Specify nominal cooling capacity

Options/Accessories

Field Installed

Condensate Drain Trap

- Available in copper or PVC

Drain Pan Overflow Switch

- Monitors condensate level in drain pan
- Shuts down unit if drain becomes clogged

LOW GWP REFRIGERANT DETECTION SYSTEM (RDS)

- Complies with UL 60335-2-40 approved standard
- Required for all systems using R-454B refrigerant
- Factory installed on all units
- Consists of a refrigerant detection sensor(s) and a mitigation control
- Ensures safe operation for systems equipped with R-454B refrigerant
- Sensor(s) monitors indoor coil area for R-454B refrigerant
- If R-454B refrigerant is detected the refrigerant detection system will prevent compressor and heating operation until R-454B refrigerant is no longer detected
- Refrigeration detection system energizes blower if any R-454B refrigerant is detected to mitigate any concentrations of refrigerant from the unit and the system

CABINET

7 Construction

- Heavy-gauge steel panels
- Full perimeter heavy-gauge galvanized steel base rail
- Base rails have rigging holes
- Three sides of the base rail have fork slots
- Raised edges around duct and power entry openings in the bottom of the unit for water protection

Airflow Choice

- Units are shipped in downflow (vertical) configuration

NOTE - Can be field converted to horizontal airflow with Horizontal Discharge Kit

Duct Flanges

- Provided for horizontal duct attachment

Power Entry

- Electrical lines can be brought through the unit base or through horizontal access knock-out

Exterior Panels

- Constructed of heavy-gauge, galvanized steel
- Textured pre-paint with polyurethane finish
- Cyclic salt fog and UV exposure up to 1,680 hours per ASTM D5894

8 Insulation

- Fully insulated with non-hygroscopic fiberglass insulation (conditioned areas)
- Unit base is fully insulated
- Base insulation serves as an air seal to the roof curb, eliminating the need to add a seal during installation

Access Panels

- Filter section
- Heating/blower section
- Compressor/controls section

Options/Accessories

Factory Installed

9 Hinged Access Panels

- Tool-less access
- Filter/Compressor section
- Controls section
- Heating/Blower section
- Panel seals and quarter-turn latching handles provide a tight air and water seal

Factory or Field Installed

Combination Coil/Hail Guards

- Heavy gauge steel frame
- Painted to match cabinet
- Expanded metal mesh protects outdoor coil

Field Installed

Horizontal Discharge Kit

- Consists of duct covers to block off downflow supply and return air openings for horizontal applications
- Also includes return air duct flanges for end return air when economizer is used in horizontal applications

NOTE - When configuring unit for horizontal application with economizer, a separate Horizontal Barometric Relief Damper with Hood must be ordered separately for installation in the return air duct.

Return Air Adaptor Plate

- For same size LCA/LGA/LHA, LCC/LGC/LHC and TCA/TGA/THA unit replacement
- Installs on return air opening in unit to match return air opening on existing roof curbs
- Also see Accessory Air Resistance table

Burglar Bars

- Heavy gauge galvanized frame
- Fully welded
- 3/4 in. bar meets ASTM specification
- Frame meets ASTM A446, A525, A526 and A527 specification
- Burglar bars designed to fit ductwork

FEATURES AND BENEFITS

BLOWER

- A wide selection of supply air blower options are available to meet a variety of airflow requirements

10 Blower Motor

- Overload protected
- Ball bearings
- Available in several different sizes to maximize air performance

Supply Air Blower

- Forward curved blades
- Double inlet
- Blower wheel statically and dynamically balanced
- Ball bearings
- Adjustable pulley (allows speed change).
- Blower assembly slides out of unit for servicing

MSAV Multi-Stage Air Volume Operation

- MSAV Multi-Stage Air Volume stages the amount of airflow according to compressor stages, heating demand, and ventilation demand
- Units utilize a Variable Frequency Drive (VFD) to stage the supply air blower airflow
- VFD alters the frequency and voltage of the power supply to the blower to control blower speed
- The supply air blower has three speeds:
 1. **Low Speed** - 1st Stage Cooling
 2. **Medium Speed** - 2nd Stage Cooling
 3. **High Speed** - Full load cooling and all heat modes
- Full speed blower operation is set by adjusting the motor pulley to deliver the desired air volume
- Ventilation speed is selectable between high and low speed

NOTE - Part load airflow in cooling mode should not be set below 220 cfm/nominal full load ton to reduce the risk of evaporator coil freeze-up.

- VFD has an operational range of -40 to 125° F outdoor air ambient temperature

NOTE - Lower operating costs are obtained when the blower is operated on lower speeds.

NOTE - Variable Frequency Drive (VFD) is designed to operate on balanced, three-phase power. Operating units on unbalanced three-phase power will reduce the reliability of all electrical components in the unit. Unbalanced power is a result of the power delivery system supplied by the local utility company. Factory-installed inverters are sized to drive blower motors with an equivalent current rating using balanced three-phase power. If unbalanced three-phase power is supplied the installer must replace the existing factory-installed inverter with an inverter that has a higher current rating to allow for the imbalance. Refer to the installation instructions for additional information and replacement information.
Required Selections

Blower Proving Switch

- Monitors blower operation, shuts down unit if blower fails

Required Selections

- Order blower motor HP and drive kit number required when base unit is ordered
- See Drive Kit Specifications Table

Options/Accessories

Field Installed

VFD Manual Bypass Kit

- Bypass Kit can be used to operate the unit in single speed (CAV) blower mode if the inverter needs to be serviced or replaced
- VFD Manual Bypass Control is a manual bypass and is set by re-configuring the wiring on the unit

Options/Accessories

Field Installed

VFD Manual Bypass Kit

- Bypass Kit can be used to operate the unit in single speed (CAV) blower mode if the inverter needs to be serviced or replaced
- VFD Manual Bypass Control is a manual bypass and is set by re-configuring the wiring on the unit

FEATURES AND BENEFITS

ELECTRICAL

Marked & Color-Coded Wiring

- All electrical wiring is color-coded and marked to identify which components it is connecting

Electrical Plugs

- Positive connection electrical plugs are used to connect common accessories or maintenance parts for easy removal or installation

Phase/Voltage Detection

- Monitors power supply to assure phase is correct at unit start-up
 - If phase is incorrect, the unit will not start and an alarm code is reported to the unit controller
- Protects unit from being started with incorrect phasing which could lead to issues such as compressors running backwards
- Voltage detection monitors power supply voltage to assure proper voltage
 - If voltage is not correct (over/under voltage conditions) the unit will not start and an alarm code is reported to the unit controller

Required Selections

Voltage Choice

- Specify when ordering base unit

Options/Accessories

Factory or Field Installed

Disconnect Switch

- Accessible from outside of unit
- Spring loaded weatherproof cover furnished

GFI Service Outlets (2)

- 115V ground fault circuit interrupter (GFCI) type options:
 - Factory installed, non-powered, field wired
 - Field installed, non-powered, field wired

Field Installed

11 Electric Heat

- Helix wound nichrome elements
- Individual element limit controls
- Wiring harness
- Unit fuse block
- See Options / Accessories tables for ordering information

GFI Weatherproof Cover

- Single-gang cover
- Heavy-duty UV-resistant polycarbonate case construction
- Hinged base cover with gasket

INDOOR AIR QUALITY

12 Air Filters

- Disposable 2-inch MERV 4 filters furnished as standard

Options/Accessories

Field Installed

Healthy Climate® High Efficiency Air Filter

- Disposable MERV 8, MERV 13, or MERV 16 (Minimum Efficiency Reporting Value based on ASHRAE 52.2) efficiency 2-inch pleated filters

Replacement Filter Media Kit With Frame

- Replaces existing pleated filter media
- Washable metal mesh screen and metal frame with clip for holding replaceable non-pleated filter

Healthy Climate® UVC Germicidal Lamps

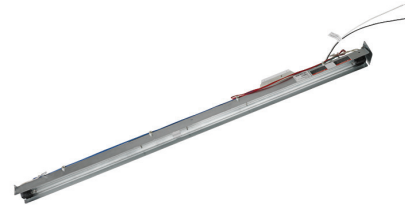

- Germicidal lamps emit ultra-violet (UV-C) energy, which has been proven to be effective in reducing microbes such as viruses, bacteria, yeasts, and molds
- This process either destroys the organism or controls its ability to reproduce
- UV-C energy greatly reduces the growth and proliferation of mold and other bioaerosols (bacteria and viruses) on illuminated surfaces (particularly coil and drain pan)
- Field installed in the blower/evaporator coil section
- Magnetic safety interlock terminates power when access panels are removed
- All necessary hardware for installation is included
- Lamps operate on 110/230V-1ph power supply

NOTE - Step-down transformer may be ordered separately for 460V and 575V units.

- Approved by ETL

Needlepoint Bipolar Ionization (NPBI) Kit

- NPBI technology has been shown to effectively reduce harmful pathogens, pollutants and odors
- Brush-type ionizer introduces a high concentration of both positive and negative ions into the air stream
- These bipolar ions are then dispersed into the occupied space through the duct system proactively reducing the airborne contaminants
- Ions travel within the building air stream and attach to particles, pathogens, and gas molecules, making them larger and easier to capture in the filtration system
- UL 2998 certified for zero ozone emission

Indoor Air Quality (CO₂) Sensors

- Monitors CO₂ levels
- Reports to the Unit Controller which adjusts economizer dampers as needed

CONTROL SYSTEM

LENNOX® CORE LITE CONTROL SYSTEM

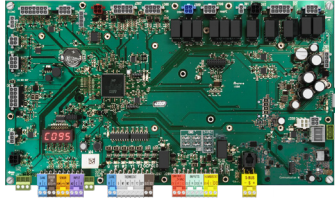

- 13 The Lennox® CORE Lite Control system is designed to accelerate equipment install and service. Standard with all Xion™ rooftop units, control system integrates key technologies that lower installation costs, drive system efficiency, and protect your investments.

The Lennox® CORE Lite Unit Controller is a microprocessor-based controller that provides flexible control of all unit functions.

CORE Mobile Service App

- Guided Setup with progress indicators, detailed help, and exportable summaries to manage simple, trouble-free setup, reducing commissioning times
- Enhanced Test Functionality provides real-time sensor readings, trending, and reports that enable easy troubleshooting
- Ability to set and configure parameters of the CORE Control System to manage sequence of operation
- Economizer test function ensures economizer is operating correctly



Additional Features:

- Built-In 7-Segment Display shows Unit Status and active alarms for easy troubleshooting
- Buttons for test and clearing delays
- SmartWire™ System with keyed and removable screw terminals ensure correct field wiring
- Profile setup copies key settings between units with the same configuration to reduce setup time
- USB port allows a technician to download and transfer unit information to help verify service was performed
- USB software updates on the Lennox® CORE Lite Unit Controller enhance functionality without the need to change components

Configurable Built-In Functions

- Up to three distinct Cooling Airflows in Thermostat Mode
- Programmable independent heating, ventilation and cooling blower speeds
- Economizer Control Options (See Economizer / Exhaust Air / Outdoor Air sections)
- Exhaust Fan Control Modes for fresh air damper position
- Configurable Morning Warm-up
- Night Setback Mode
- Demand Control Ventilation
- Humiditrol® Operation

Component Protection / Unit Safeguards:

- Compressor Time-Off Delay
- Adjustable Blower On/Off Delay
- Return Air Temperature Limit Control
- Safety Switch Input allows Controller to respond to a external safety switch trip
- Service Relay Output
- Thermostat Bounce Delay
- Smoke Alarm Mode has four choices (unit off, positive pressure, negative pressure, purge)
- “Strike Three” Protection
- Gas Valve Time Delay Between First and Second Stage
- Minimum Compressor Run Time

Control Methods / Interfaces:

- DDC and 24V Thermostat
- BACnet MS/TP (Field Option)
- Lennox S-BUS
- Zone Temperature Sensor Input
- Dehumidistat and Humidity Sensor Inputs
- Indoor Air Quality Inputs (2)
- Built-in Control Parameter Defaults
- Permanent Diagnostic Code Storage
- Field Adjustable Control Parameters (Over 100 settings)
- Multiple Configurable Digital Inputs
- LED Indicators

NOTE - Lennox® CORE Control System features vary with the type of rooftop unit in which the control is installed.

CONTROL SYSTEM

LENNOX® CORE LITE CONTROL SYSTEM (continued)

Controls Options

Field Installed

Dirty Filter Switch

- Senses static pressure increase and issues alarm if necessary

Smoke Detector

- Photoelectric type
- Installed in supply air section, return air section or both sections
- Available with power board and single sensor (supply or return) or power board and two sensors (supply and return)
- Power board located in unit control compartment

Commercial Control Systems

Field Installed

Interoperability via BACnet® Protocols

- Communication compatible with third-party automation systems that support the BACnet Application Specific Controller device profile

Thermostats and Room Sensors

- Control system and thermostat options, see page 11

OPTIONS / ACCESSORIES

ECONOMIZER

- Economizer operation is set and controlled by the Lennox® CORE Lite Unit Controller
- Simple plug-in connections from economizer to control system for easy installation
- All Xion™ rooftop units are equipped with factory installed CEC Title 24 approved sensors for outside, return and discharge air temperature monitoring

NOTE - Optional sensors may be used instead of unit sensors to determine whether outdoor air is suitable for free cooling. See the Options/ Accessories table.

Factory or Field Installed

High Performance Economizer

- Approved for California Title 24 building standards
- Low leakage dampers are Air Movement and Control Association International (AMCA) Class 1A Certified - Maximum 3 CFM per sq. ft. leakage at 1 in. w.g.
- ASHRAE 90.1 compliant
- Downflow or Horizontal with Outdoor Air Hood
- Outdoor Air Hood is included when economizer is factory installed and is furnished with economizer when ordered for field installation
- Barometric Relief Dampers with Exhaust Hood are also furnished
- Linked damper action
- High torque 24-volt fully-modulating spring return damper motor
- Return air and outdoor air dampers
- Plug-in connections to unit

NOTE - Horizontal applications use furnished outdoor air hood and barometric relief dampers with exhaust hood. Requires optional Horizontal Discharge Kit. See dimension drawing on page 35.

Horizontal applications in reduced spaces requires optional Horizontal Low Profile Barometric Relief Dampers with Exhaust Hood and Horizontal Discharge Kit. See dimension drawing on page 36.

NOTE - High Performance Economizers are not approved for use with enthalpy controls in Title 24 applications.

NOTE - The Free Cooling setpoint for Title 24 applications must be set based on the Climate Zone where the system is installed. See Section 140.4 "Prescriptive Requirements for Space Conditioning Systems" of the California Energy Commission's 2022 Building Energy Efficiency Standards.

NOTE - Refer to Installation Instructions for complete setup information.

OPTIONS / ACCESSORIES

ECONOMIZER (continued)

Factory or Field Installed

Single Enthalpy Control (Not for Title 24)

- Outdoor air enthalpy sensor enables economizer if the outdoor enthalpy is less than the setpoint of the control

Field Installed

Differential Enthalpy Control (Not for Title 24)

- Order two Single Enthalpy Controls
- One is field installed in the return air section
- One is installed in the outdoor air section
- Allows the economizer control to select between outdoor air or return air, whichever has lower enthalpy

Differential Sensible Control

- Factory setting
- Uses outdoor air and return air sensors that are furnished with the unit
- The Lennox® CORE Lite Unit Controller compares outdoor air and return air setpoints and activates the economizer when the outdoor air temperature is below the configured setpoint and cooler than return air

NOTE - Differential Sensible Control can be configured in the field to provide Offset Differential Sensible Control or Single Sensible Control.

In Offset Differential Sensible Control mode, the economizer is enabled if the temperature differential (offset) between outdoor air and return air reaches the configured setpoint.

In Single Sensible Control mode, the economizer is enabled when outdoor air temperature falls below the configured setpoint.

EXHAUST

Field Installed

Power Exhaust Fan

- Installs internal to unit for downflow applications only with economizer option
- Provides exhaust air pressure relief
- Interlocked to run when supply air blower is operating
- Fan runs when outdoor air dampers are 50% open (adjustable)
- Motor is overload protected
- Fan is 20 in. diameter
- Five blades
- One 1/3 HP motor

NOTE - Requires Economizer and Downflow Barometric Relief Dampers.

Horizontal Low Profile Barometric Relief Dampers

- For use when unit is configured for horizontal applications requiring an economizer in a reduced space
- Allows relief of excess air
- Aluminum blade dampers prevent blow back and outdoor air infiltration during off cycle
- Field installed in return air duct
- Bird screen and hood furnished

NOTE - Requires Horizontal Discharge Kit.

OPTIONS / ACCESSORIES

OUTDOOR AIR

Field Installed

Motorized Outdoor Air Damper

- Linked mechanical dampers
- Fully modulating spring return damper motor with plug-in connection
- 0 to 25% (fixed) outdoor air adjustable
- Installs in unit
- Outdoor air hood with bird screen included

Manual Outdoor Air Damper

- Adjustable slide damper
- Installed in unit
- Outdoor air hood with bird screen included

ROOF CURBS

Field Installed

- Nailer strip furnished (downflow only)
- Mates to unit
- US National Roofing Contractors Approved
- Shipped knocked down

Hybrid Roof Curbs, Downflow

- Interlocking tabs fasten corners together
- No tools required for assembly
- Can also be fastened together with furnished hardware
- Available in 8, 14, 18, and 24 inch heights

Adjustable Pitch Curb

- Fully adjustable pitch curbs (3/4 in. per foot in any direction) provide a level platform for rooftop units allowing flexible installations on roofs with uneven or sloped angles
- Interlocking tabs fasten corners together
- No tools required for assembly
- Hardware is furnished to connect upper curb with lower curb
- Available in 14 inch height

Adaptor Curbs (not shown)

- Curbs are regionally sourced
- Dimensions vary based upon the source

NOTE - Contact your local sales representative for a detailed cut sheet with applicable dimensions.

CEILING DIFFUSERS

Field Installed

Ceiling Diffusers (Flush or Step-Down)

- White powder coat finish on diffuser face and grilles
- Insulated UL listed duct liner
- Diffuser box has collars for duct connection
- Step-down diffusers have double deflection blades
- Flush diffusers have fixed blades
- Provisions for suspending
- Internally sealed to prevent recirculation
- Removable return air grille
- Adapts to T-bar ceiling grids or plaster ceilings

Transitions (Supply and Return)

- Used with diffusers
- Installs in roof curb
- Galvanized steel construction
- Flanges furnished for duct connection to diffusers
- Fully insulated

OPTIONAL CONVENTIONAL TEMPERATURE CONTROL SYSTEMS

CS8500 Commercial 7-Day Programmable Thermostat

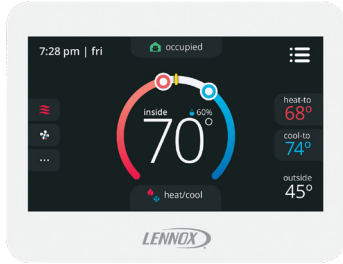

- Fully Communicating Sensor
- Full Color Touchscreen Interface
- Variable Speed System Control (On Compatible Units)
- Up To 4 Heat / 4 Cool
- Built-In Sensors For Temperature, Humidity And Optional CO₂
- Remote Sensor Options For Occupancy, Temperature
- BACnet Capable Options
- 5-2 or 7-Day Scheduling
- Smooth Setback Recovery
- Heat/Cool Auto-Changeover
- Four-Wire Installation
- FDD, ASHRAE, IECC Compliant

CS7500 Commercial 7-Day Programmable Thermostat



- Premium Universal Thermostat
- Full Color Touchscreen Interface
- Up To 4 Heat / 3 Cool
- Built-In Sensors For Temperature and Humidity
- Remote Sensors Options For Temperature, Discharge Air, Outdoor Air
- 5-2 or 7-Day Scheduling
- Smooth Setback Recovery
- Heat/Cool Auto-Changeover
- FDD, ASHRAE, IECC Compliant

CS3000 Commercial 5-2 Day Programmable Thermostat

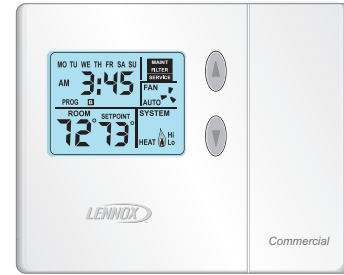

- Conventional Multi-Stage Thermostat
- Intuitive Display
- Push-Button Operation
- Up To 2 Heat / 2 Cool
- Built-In Temperature Sensor
- Remote Temperature Sensing
- Up to 5-2 Day Scheduling
- Smooth Setback Recovery
- Heat/Cool Auto-changeover

Wired Temperature/Humidity Room Sensor (Non-Communicating)



- Terminal blocks for wiring connections
- Five-wire sensor connection
- Off-white plastic enclosure
- Non-adjustable
- Relative humidity range: 0 -100%
- +/- 3% Accuracy

OPTIONAL CONVENTIONAL TEMPERATURE CONTROL SYSTEMS

Description	Order Number
CS8500 Commercial 7 Day Programmable Thermostat	
CS8500 7-Day Thermostat	No CO ₂ Sensing 24K55
	With CO ₂ Sensing 24K53
Sensors/Accessories	¹ Remote non-adjustable wall-mount 10k 47W37
	¹ Remote non-adjustable wall-mount 11k 94L61
CS7500 Commercial 7-Day Programmable Thermostat	
CS7500 7-Day Thermostat	24K41
Sensors/Accessories	² Remote non-adjustable wall-mount 20k 47W36
	² Remote non-adjustable wall-mount 10k 47W37
	Remote non-adjustable discharge air (duct mount) 19L22
	Outdoor temperature sensor X2658
CS3000 Commercial 5-2 Day Programmable Thermostat	
CS3000 5-2 Day Thermostat	11Y05
Sensors/Accessories	Remote non-adjustable wall mount 10k averaging 47W37
	Thermostat wall mounting plate X2659
Universal Thermostat Guard with Lock (clear)	
	Inside Dimensions (H x W x D) 5-7/8 x 8-3/8 x 3 in. 39P21
Temperature/Humidity Room Sensor	
A335MT13AE1 Wired Temperature/Humidity Room Sensor (Non-Communicating)	21W06

¹ Up to nine of the same type remote temperature sensors can be connected in parallel.

² Remote wall-mount sensors can be applied in any of the following combinations:
One Sensor - (1) 47W36, Two Sensors - (2) 47W37, Three Sensors - (2) 47W36 and (1) 47W37
Four Sensors - (4) 47W36, Five Sensors - (3) 47W36 and (2) 47W37

Objective: Outline the unit functions as a result of room thermostat or zone sensor demands.

Given: When economizer is present, it will function as an integral part of the unit cooling system. When not present, unit will function as if economizer is present but outdoor ambient is high and sensed as not suitable.

UNIT OPERATION WITH 2-STAGE THERMOSTAT (2 COOL AND 2 HEAT STAGES, Y1, Y2, W1, W2)

SUPPLY AIR BLOWER SPEED

Unit has following supply air blower speed setting:

- Ventilation speed
- Cooling Speed - Low
- Cooling Speed - High
- Heating speed
- Smoke speed (Used only in smoke removal option - not discussed)

¹ UNIT FEATURES AN ECONOMIZER AND OUTDOOR AIR IS SUITABLE

Cooling - Thermostat Mode (Y1, Y2)

Y1 Demand:

All compressors are off, supply air blower is on low cooling speed to minimize blower power consumption, economizer modulates (minimum to maximum open position) to maintain 55°F supply air temperature (default unit controller setting).

Y2 Demand:

All compressors are off, supply air blower is on high cooling speed providing higher cooling capacity, and economizer modulates to maintain 55°F supply air temperature.

If economizer stays at maximum open for 3 minutes, compressor 1 is energized while supply air blower stays on high cooling speed providing maximum cooling capacity.

¹ Outdoor air suitability is determined by the energy state of outdoor ambient (enthalpy or sensible) and its ability to achieve the desired free cooling effects. Outdoor air suitability can also be determined by a third party controller and provided to the rooftop unit via a network connection.

UNIT DOES NOT FEATURE AN ECONOMIZER OR OUTDOOR AIR IS NOT SUITABLE

Y1 Demand:

Compressor 1 operates and supply air blower operates at low cooling speed.

Y2 Demand:

All compressors operate and supply air blower operates at high cooling speed.

SEQUENCE OF OPERATION

UNIT OPERATION WITH 3-STAGE THERMOSTAT OR ZONE SENSOR (3 COOL AND 2 HEAT STAGES, Y1, Y2, Y3 AND W1, W2)

SUPPLY AIR BLOWER SPEED

Unit has following supply air blower speed setting:

- Ventilation speed
- Cooling Speed - Low
- Cooling Speed - Medium
- Cooling Speed - High
- Heating speed
- Smoke speed (Used only in smoke removal option - not discussed)

COOLING

¹ Unit Features An Economizer And Outdoor Air Is Suitable

Thermostat or Zone Sensor Mode (Y1, Y2, Y3)

Y1 Demand:

All compressors are off, supply air blower is on low cooling speed to minimize blower power consumption, economizer modulates (minimum to maximum open position) to maintain 55°F supply air temperature (default unit controller setting).

Y2 Demand:

All compressors are off, supply air blower is on high cooling speed providing higher cooling capacity, and economizer modulates to maintain 55°F supply air temperature. If economizer stays at maximum open for 3 minutes, compressor 1 is energized while supply air blower stays on high cooling speed providing maximum cooling capacity. After compressors are energized the economizer stays at maximum open.

Y3 Demand:

Compressors 1 and 2 are energized while supply air blower stays on high cooling speed. Outdoor air suitability is determined by the energy state of outdoor ambient (enthalpy or sensible) and its ability to achieve the desired free cooling effects. Outdoor air suitability can also be determined by a third party controller and provided to the rooftop unit via a network connection.

Unit Does Not Feature An Economizer or Outdoor Air Is Not Suitable

Thermostat or Zone Sensor Mode (Y1, Y2, Y3)

Y1 Demand:

Compressor 1 operates at part load and supply air blower operates at low cooling speed.

Y2 Demand:

Compressor 1 operates at part load with compressor 2 ON, and supply air blower operates at medium cooling speed.

Y3 Demand:

All compressors operate and supply air blower operates at high cooling speed.

SEQUENCE OF OPERATION

DEFROST

Coil Sensors (RT48 - Circuit 1 and RT49 - Circuit 2) and Ambient Sensor (RT17) provides input to the Lennox® CORE Unit Controller to initiate a defrost cycle if needed.

Coil sensors are located on a return bend for each circuit on the front of the outdoor coil.

Ambient sensor is located on the inside of the corner mullion on the back of the outdoor coil section.

If a coil sensor measures a temperature below 35°F during mechanical heating mode, defrost logic is enabled. The system will constantly monitor coil and ambient temperatures and will initiate a defrost cycle if the controller determines that the target temperature difference between the coil and ambient temperature has been satisfied, or when the accumulated run time with coil temperature below 35°F reaches 6 hours.

Defrost will not be activated on more than one circuit at the time.

If the ambient sensor fails, or the circuit is in uncalibrated state, the controller will switch to time/temperature defrost operation.

Electric heat is energized during a defrost cycle to maintain discharge air temperature.

HEATING MODE: THERMOSTAT OR ZONE SENSOR

W1 Demand:

A first-stage heating demand (W1) will energize compressors 1 and 2 and the outdoor fans.

NOTE – L1 & L2 reversing valves are de-energized in the heating mode.

Units With Optional Electric Heat:

An increased heating demand (W2) will energize electric heat.

NOTE - Compressors 1 and 2 stay energized.

Units With Optional Two-Stage Electric Heat and Zone Sensor mode:

An increased heating demand (H2) will energize 1st stage of electric heat.

An increased heating demand (H3) will energize 2nd stage of electric heat.

NOTE – Compressors 1 and 2 stay energized.

All Electric heat modules are energized during the defrost cycle (W1) to temper discharge air temperature.

ACCESSORIES

Modulating Outdoor Air Damper

The minimum damper position for “occupied low blower” and “occupied high blower” is adjusted during unit setup to provide minimum fresh air requirements per ASHRAE 62.1 at the corresponding supply air blower speeds.

When supply air blower is off or the unit is in unoccupied mode, the outdoor air damper is closed.

When unit is in occupied mode and supply air blower is operating at a speed below the “midpoint” blower speed, the outdoor air damper is at minimum “low blower” position.

When unit is in occupied mode and supply air blower is operating at a speed equal to or above the “midpoint” blower speed, the outdoor air damper is at minimum “high blower” position.

NOTE - The “midpoint” blower speed is an average of the minimum and maximum blower speed (minimum speed + maximum speed divided by 2).

Power Exhaust Operation

NOTE - POWER EXHAUST OPERATION IS THE SAME FOR ALL CONTROL OPTIONS

Single-stage power exhaust fan is an option available to units with Economizer and for downflow applications only.

Power exhaust fan operates when economizer outdoor air dampers are 50% open (adjustable) and when supply air blower is ON.

OPTIONS / ACCESSORIES

Item Description	Order Number	Size			
		092	102	120	
COOLING SYSTEM					
Condensate Drain Trap	PVC	22H54	X	X	X
	Copper	76W27	X	X	X
Drain Pan Overflow Switch		21Z07	X	X	X
BLOWER - SUPPLY AIR					
Blower Motors	Belt Drive - 2 HP	Factory	O	O	O
	Belt Drive - 3 HP	Factory	O	O	O
	Belt Drive - 5 HP	Factory	O	O	O
VFD Manual Bypass Kit		37G66	X	X	X
Drive Kits See Blower Data Tables for selection	Kit #1 590-890 rpm	Factory	O	O	O
	Kit #2 800-1105 rpm	Factory	O	O	O
	Kit #3 795-1195 rpm	Factory	O	O	O
	Kit #4 730-970 rpm	Factory	O	O	O
	Kit #5 940-1200 rpm	Factory	O	O	O
	Kit #6 1015-1300 rpm	Factory	O	O	O
	Kit #10 900-1135 rpm	Factory	O	O	O
	Kit #11 1050-1335 rpm	Factory	O	O	O
VFD Manual Bypass Kit		37G66	X	X	X
CABINET					
Burglar Bars		Y3355	X	X	X
Combination Coil/Hail Guards		13T24	OX	OX	OX
Hinged Access Panels		Factory	O	O	O
Horizontal Discharge Kit		51W25	X	X	X
Return Air Adaptor Plate (for same size LCA/LGA/LHA, LCC/LGC/LHC and TCA/TGA/THA unit replacement)		54W96	X	X	X
CONTROLS					
NOTE - Also see Conventional Thermostat Control Systems on page 12 for Additional Options.					
BACnet® MS/TP Module		38B35	X	X	X
Dirty Filter Switch		53W67	X	X	X
Smoke Detector - Supply or Return (Power board and one sensor)		31A68	X	X	X
Smoke Detector - Supply and Return (Power board and two sensors)		31A69	X	X	X

NOTE - Order numbers shown are for ordering field installed accessories.

OX - Configure To Order (Factory Installed) or Field Installed

O = Configure To Order (Factory Installed)

X = Field Installed

OPTIONS / ACCESSORIES

Item Description	Order Number	Size			
		092	102	120	
INDOOR AIR QUALITY					
Healthy Climate® High Efficiency Air Filters 20 x 25 x 2 (Order 4 per unit)	MERV 8	50W61	X	X	X
	MERV 13	52W41	X	X	X
	MERV 16	21U41	X	X	X
Replacement Media Filter With Metal Mesh Frame (includes non-pleated filter media)		Y3063	X	X	X
Indoor Air Quality (CO₂) Sensors					
Sensor - Wall-mount, off-white plastic cover with LCD display		77N39	X	X	X
Sensor - Wall-mount, off-white plastic cover, no display		87N53	X	X	X
Sensor - Black plastic case, LCD display, rated for plenum mounting		87N52	X	X	X
Sensor - Black plastic case, no display, rated for plenum mounting		87N54	X	X	X
CO ₂ Sensor Duct Mounting Kit - for downflow applications		23Y47	X	X	X
Aspiration Box - for duct mounting non-plenum rated CO ₂ sensors (77N39)		90N43	X	X	X
Needlepoint Bipolar Ionization (NPBI)					
Needlepoint Bipolar Ionization Kit		21U36	X	X	X
UVC Germicidal Lamps					
¹ Healthy Climate® UVC Light Kit (110/230V-1ph)		21A93	X	X	X
Step-Down Transformers	460V primary, 230V secondary	10H20	X	X	X
	575V primary, 230V secondary	10H21	X	X	X
ELECTRICAL					
Voltage 60 Hz	208/230V - 3 phase	Factory	O	O	O
	460V - 3 phase	Factory	O	O	O
	575V - 3 phase	Factory	O	O	O
Disconnect Switch - See Electrical/Electric Heat tables for selection	80 amp	54W56	OX	OX	OX
	150 amp	54W57	OX	OX	OX
GFI Service Outlets	15 amp non-powered, field-wired (208/230V, 460V only)	74M70	OX	OX	OX
	² 20 amp non-powered, field-wired (208/230V, 460V, 575V)	67E01	X	X	X
	² 20 amp non-powered, field-wired (575V)	Factory	O	O	O
Weatherproof Cover for GFI		10C89	X	X	X
ELECTRIC HEAT					
7.5 kW	208/240V-3ph	30V21	X	X	
	460V-3ph	30V22	X	X	
	575V-3ph	30V23	X	X	
15 kW	208/240V-3ph	30V27	X	X	X
	460V-3ph	30V28	X	X	X
	575V-3ph	30V29	X	X	X
22.5 kW	208/240V-3ph	30V33	X	X	X
	460V-3ph	30V34	X	X	X
	575V-3ph	30V35	X	X	X
30 kW	208/240V-3ph	30V39	X	X	X
	460V-3ph	30V40	X	X	X
	575V-3ph	30V41	X	X	X
45 kW	208/240V-3ph	30V45	X	X	X
	460V-3ph	30V46	X	X	X
	575V-3ph	30V47	X	X	X
60 kW	208/240V-3ph	30V51			X
	460V-3ph	30V52			X
	575V-3ph	30V53			X

¹ Lamps operate on 110-230V single-phase power supply. Step-down transformer may be ordered separately for 460V and 575V units. Alternately, 110V power supply may be used to directly power the UVC ballast(s).

² Canada requires a minimum 20 amp circuit. Select 20 amp, non-powered, field wired GFI.

NOTE - Order numbers shown are for ordering field installed accessories.

OX - Configure To Order (Factory Installed) or Field Installed

O = Configure To Order (Factory Installed)

X = Field Installed

OPTIONS / ACCESSORIES

Item Description	Order Number	Size		
		092	102	120
ECONOMIZER				
High Performance Economizer (Approved for California Title 24 Building Standards / AMCA Class 1A Certified)				
High Performance Economizer (Downflow or Horizontal)	20U80	OX	OX	OX
Includes Economizer Dampers with Outdoor Air Hood and Barometric Relief Dampers with Exhaust Hood				
Downflow Applications - Use furnished Outdoor Air Hood and Barometric Relief Dampers with Exhaust Hood				
Horizontal Applications - Use furnished Outdoor Air Hood and Barometric Relief Dampers with Exhaust Hood - Order Horizontal Discharge Kit separately				
Horizontal Applications (reduced height) - Order Horizontal Low Profile Barometric Relief Dampers with Exhaust Hood and Horizontal Discharge Kit (51W25) separately				
Horizontal Low Profile Barometric Relief Dampers				
Horizontal Low Profile Barometric Relief Dampers With Exhaust Hood	53K04	X	X	X
Economizer Controls				
Differential Enthalpy (Not for Title 24)	Order 2 21Z09	X	X	X
Sensible Control	Sensor is Furnished Factory	O	O	O
Single Enthalpy (Not for Title 24)	21Z09	OX	OX	OX
OUTDOOR AIR				
Outdoor Air Dampers with Outdoor Air Hood				
Motorized	14G28	X	X	X
Manual	14G29	X	X	X
POWER EXHAUST				
Standard Static	208/230V-3ph 53W44	X	X	X
	460V-3ph 53W45	X	X	X
	575V-3ph 53W46	X	X	X
ROOF CURBS				
Hybrid Roof Curbs, Downflow				
8 in. height	C1CURB70B-1 11F54	X	X	X
14 in. height	C1CURB71B-1 11F55	X	X	X
18 in. height	C1CURB72B-1 11F56	X	X	X
24 in. height	C1CURB73B-1 11F57	X	X	X
Adjustable Pitch Curb, Downflow				
14 in. height	C1CURB55B-1 54W50	X	X	X
CEILING DIFFUSERS				
Step-Down - Order one	RTD11-95S 13K61	X		
	RTD11-135S 13K62		X	X
Flush - Order one	FD11-95S 13K56	X		
	FD11-135S 13K57		X	X
Transitions (Supply and Return) - Order one	C1DIFF30B-1 12X65	X		
	C1DIFF31B-1 12X66		X	X

NOTE - Order numbers shown are for ordering field installed accessories.

OX - Configure To Order (Factory Installed) or Field Installed

O = Configure To Order (Factory Installed)

X = Field Installed

SPECIFICATIONS

Model		LHX092S5M	LHX102S5M	LHX120S5M	
Nominal Tonnage		7.5	8.5	10	
Efficiency Type		Standard	Standard	Standard	
Blower Type		MSAV® Multi-Stage Air Volume	MSAV® Multi-Stage Air Volume	MSAV® Multi-Stage Air Volume	
Cooling Performance	Gross Cooling Capacity (Btuh)	91,600	103,400	119,500	
	¹ Net Cooling Capacity (Btuh)	89,000	100,000	116,000	
	¹ AHRI Rated Air Flow (cfm)	2800	3200	3400	
	¹ IEER (Btuh/Watt)	15.0	15.0	15.0	
	¹ EER (Btuh/Watt)	11.0	11.0	11.0	
	Total Unit Power (kW)	8.1	9.1	10.7	
Heating Performance	¹ Total High Heating Capacity (Btuh)	89,000	100,000	118,000	
	¹ COP	3.4	3.4	3.4	
	Total Unit Power (kW)	7.6	8.5	9.9	
	¹ Total Low Heating Capacity (Btuh)	53,000	59,000	70,000	
	¹ COP	2.25	2.25	2.25	
	Total Unit Power (kW)	6.9	7.8	9.1	
Sound Rating Number	dBA	88	88	88	
Refrigerant Charge	Refrigerant Type	R-454B	R-454B	R-454B	
	Circuit 1	13 lbs. 4 oz.	12 lbs. 8 oz.	12 lbs. 7 oz.	
	Circuit 2	13 lbs. 8 oz.	14 lbs. 0 oz.	12 lbs. 4 oz.	
Electric Heat Available - See page 17		7.5-15-22.5-30-45 kW	7.5-15-22.5-30-45 kW	7.5-15-22.5-30-45-60 kW	
Compressor Type (number)		Two-Stage Scroll (1), Single-Stage Scroll (1)			
Outdoor Coils	Net face area - ft. ² (total)	28.8	28.8	28.8	
	Rows	3	3	3	
	Fins - in.	3	3	3	
Outdoor Coil Fans	Motor HP (number and type)	1/2 (2 PSC)	1/2 (2 PSC)	1/2 (2 PSC)	
	Rpm	1075	1075	1075	
	Watts	1075	1075	1075	
	Diameter - (No.) in.	(2) 24	(2) 24	(2) 24	
	Blades	3	3	3	
	Total Air volume - cfm	8800	8800	8800	
Indoor Coils	Net face area - ft. ² (total)	13.54	13.54	13.54	
	Tube diameter - in.	3/8	3/8	3/8	
	Rows	4	4	4	
	Fins - in.	14	14	14	
	Condensate drain size (NPT) - in.	(1) 1			
	Expansion device type	Balanced Port Thermostatic Expansion Valve			
² Indoor Blower and Drive Selection	Nominal motor HP	2, 3, 5			
	Maximum usable motor HP (US)	2.3, 3.45, 5.75			
	Motor - Drive kit number	2 HP Kit 1 590-890 rpm Kit 2 800-1105 rpm Kit 3 795-1195 rpm			
		3 HP Kit 4 730-970 rpm Kit 5 940-1200 rpm Kit 6 1015-1300 rpm			
		5 HP Kit 10 900-1135 rpm Kit 11 1050-1335 rpm			
	Wheel (Number) diameter x width - in.	(1) 15 X 15			
	Filters	Type of filter	MERV 4, Disposable		
		Number and size - in.	(4) 20 x 25 x 2		
	Line voltage data (Volts-Phase-Hz)		208/230-3-60 460-3-60 575-3-60		

NOTE - Net capacity includes evaporator blower motor heat deduction. Gross capacity does not include evaporator blower motor heat deduction.

¹ AHRI Certified to AHRI Standard 340/360:

Cooling Ratings - 95°F outdoor air temperature and 80°F db/67°F wb entering indoor coil air.

High Temperature Heating Ratings - 47°F db/43°F wb outdoor air temperature and 70°F entering indoor coil air.

Low Temperature Heating Ratings - 17°F db/15°F wb outdoor air temperature and 70°F entering indoor coil air.

² Using total air volume and system static pressure requirements determine from blower performance tables rpm and motor output required. Maximum usable output of motors furnished are shown. In Canada, nominal motor output is also maximum usable motor output. If motors of comparable output are used, be sure to keep within the service factor limitations outlined on the motor nameplate.

³ Standard motor and drive kit furnished with unit.

NOTE - Motor service factor limit - 1.0.

COOLING/HEATING RATINGS

NOTE – For Temperatures and Capacities not shown in tables, see bulletin – Cooling Unit Rating Table Correction Factor Data in Miscellaneous Engineering Data section.

7.5 TON COOLING - LHX092S5M (1 COMPRESSOR - PART LOAD)

Entering Wet Bulb Temperature	Total Air Volume	Outdoor Air Temperature Entering Outdoor Coil																			
		65°F					75°F					85°F					95°F				
		Total Cool Cap.	Comp. Motor Input	Sensible To Total Ratio (S/T)			Total Cool Cap.	Comp. Motor Input	Sensible To Total Ratio (S/T)			Total Cool Cap.	Comp. Motor Input	Sensible To Total Ratio (S/T)			Total Cool Cap.	Comp. Motor Input	Sensible To Total Ratio (S/T)		
				Dry Bulb					Dry Bulb					Dry Bulb					Dry Bulb		
cfm	kBtuh	kW	75°F	80°F	85°F	kBtuh	kW	75°F	80°F	85°F	kBtuh	kW	75°F	80°F	85°F	kBtuh	kW	75°F	80°F	85°F	
63°F	1600	38.7	1.19	0.81	0.99	1	36.8	1.47	0.84	1	1	34.8	1.8	0.86	1	1	32.5	2.14	0.9	1	0.59
	1980	40.7	1.13	0.89	1	1	38.9	1.42	0.92	1	1	36.7	1.76	0.95	1	1	34.4	2.12	0.99	1	0.59
	2360	42.5	1.07	0.96	1	1	40.6	1.37	0.98	1	1	38.3	1.73	1	1	1	35.9	2.11	1	1	0.59
67°F	1600	41.1	1.12	0.59	0.79	0.97	39	1.42	0.6	0.81	0.99	36.7	1.76	0.61	0.84	1	33.9	2.13	0.63	0.88	0.59
	1980	42.5	1.06	0.63	0.86	1	40.3	1.38	0.64	0.89	1	37.7	1.74	0.67	0.93	1	35.1	2.12	0.69	0.97	0.59
	2360	43.6	1.02	0.68	0.93	1	41.4	1.35	0.7	0.97	1	38.6	1.72	0.72	0.99	1	36	2.11	0.76	1	0.59
71°F	1600	43.7	1.02	0.38	0.57	0.76	41.5	1.35	0.38	0.58	0.78	38.9	1.72	0.38	0.6	0.81	36.2	2.1	0.38	0.62	0.59
	1980	45.1	0.97	0.39	0.62	0.83	42.8	1.31	0.4	0.63	0.86	40.1	1.69	0.4	0.66	0.89	37.4	2.09	0.41	0.68	0.59
	2360	46.2	0.92	0.41	0.67	0.91	43.8	1.28	0.41	0.68	0.94	41	1.67	0.42	0.72	0.98	38.1	2.08	0.43	0.75	0.59

7.5 TON COOLING - LHX092S5M (2 COMPRESSORS - PART LOAD / FULL LOAD)

Entering Wet Bulb Temperature	Total Air Volume	Outdoor Air Temperature Entering Outdoor Coil																			
		85°F					95°F					105°F					115°F				
		Total Cool Cap.	Comp. Motor Input	Sensible To Total Ratio (S/T)			Total Cool Cap.	Comp. Motor Input	Sensible To Total Ratio (S/T)			Total Cool Cap.	Comp. Motor Input	Sensible To Total Ratio (S/T)			Total Cool Cap.	Comp. Motor Input	Sensible To Total Ratio (S/T)		
				Dry Bulb					Dry Bulb					Dry Bulb					Dry Bulb		
cfm	kBtuh	kW	75°F	80°F	85°F	kBtuh	kW	75°F	80°F	85°F	kBtuh	kW	75°F	80°F	85°F	kBtuh	kW	75°F	80°F	85°F	
63°F	1800	78.3	4.41	0.68	0.8	0.92	73.6	5.08	0.69	0.82	0.93	68.4	5.82	0.7	0.84	0.94	63.1	6.63	0.71	0.86	0.97
	2250	83.4	4.38	0.72	0.86	0.96	78.4	5.06	0.73	0.88	0.98	73.4	5.81	0.75	0.9	0.99	67.4	6.63	0.78	0.92	1
	2700	87.5	4.35	0.77	0.92	1	82.2	5.05	0.79	0.93	1	76.9	5.8	0.81	0.95	1	70.8	6.63	0.83	0.97	1
67°F	1800	84.1	4.37	0.54	0.65	0.77	79.3	5.05	0.53	0.66	0.78	73.9	5.81	0.54	0.67	0.8	67.6	6.63	0.54	0.69	0.83
	2250	89.2	4.35	0.56	0.69	0.83	83.5	5.04	0.56	0.71	0.85	77.9	5.8	0.57	0.73	0.87	71.5	6.63	0.58	0.75	0.9
	2700	92.3	4.33	0.59	0.74	0.89	86.9	5.03	0.59	0.76	0.9	80.9	5.8	0.61	0.78	0.92	74.4	6.63	0.61	0.81	0.96
71°F	1800	89.8	4.33	0.41	0.52	0.63	84.3	5.03	0.4	0.52	0.63	78.8	5.8	0.39	0.52	0.64	72.8	6.63	0.39	0.53	0.64
	2250	94.5	4.3	0.42	0.55	0.67	89.2	5.02	0.42	0.55	0.68	83.4	5.8	0.41	0.56	0.7	77.1	6.64	0.41	0.57	0.72
	2700	98.2	4.28	0.43	0.58	0.72	92.7	5.01	0.43	0.58	0.73	86.6	5.79	0.43	0.59	0.75	80	6.64	0.43	0.6	0.79

7.5 TON COOLING - LHX092S5M (2 COMPRESSOR - FULL LOAD)

Entering Wet Bulb Temperature	Total Air Volume	Outdoor Air Temperature Entering Outdoor Coil																			
		85°F					95°F					105°F					115°F				
		Total Cool Cap.	Comp. Motor Input	Sensible To Total Ratio (S/T)			Total Cool Cap.	Comp. Motor Input	Sensible To Total Ratio (S/T)			Total Cool Cap.	Comp. Motor Input	Sensible To Total Ratio (S/T)			Total Cool Cap.	Comp. Motor Input	Sensible To Total Ratio (S/T)		
				Dry Bulb					Dry Bulb					Dry Bulb					Dry Bulb		
cfm	kBtuh	kW	75°F	80°F	85°F	kBtuh	kW	75°F	80°F	85°F	kBtuh	kW	75°F	80°F	85°F	kBtuh	kW	75°F	80°F	85°F	
63°F	2400	96.5	5.4	0.7	0.83	0.96	91.4	6.13	0.71	0.84	0.98	85.8	6.98	0.72	0.87	0.99	79.2	7.98	0.74	0.9	1
	3000	101.8	5.39	0.75	0.9	1	95.8	6.12	0.76	0.93	1	89.7	6.97	0.78	0.95	1	83.9	7.96	0.8	0.98	1
	3600	105.1	5.39	0.8	0.97	1	99.8	6.12	0.82	0.99	1	94.2	6.96	0.84	1	1	88.5	7.94	0.87	1	1
67°F	2400	102.8	5.39	0.55	0.67	0.79	97.2	6.12	0.55	0.68	0.81	91.4	6.97	0.55	0.69	0.83	85.5	7.96	0.56	0.71	0.88
	3000	107.7	5.38	0.58	0.72	0.87	102	6.11	0.58	0.74	0.89	96	6.96	0.59	0.76	0.92	89.4	7.94	0.6	0.78	0.98
	3600	111.6	5.37	0.61	0.78	0.94	105.7	6.11	0.62	0.79	0.96	99.2	6.96	0.62	0.82	0.99	92.4	7.93	0.64	0.84	1
71°F	2400	108.9	5.38	0.41	0.53	0.65	103.5	6.11	0.41	0.53	0.66	97.6	6.96	0.41	0.54	0.67	91.2	7.94	0.4	0.54	0.68
	3000	114.5	5.36	0.42	0.56	0.7	108.7	6.1	0.42	0.57	0.71	102.5	6.94	0.42	0.58	0.73	95.7	7.92	0.42	0.59	0.76
	3600	118.2	5.35	0.44	0.6	0.75	112.3	6.09	0.44	0.61	0.77	105.8	6.94	0.44	0.62	0.79	98	7.91	0.44	0.63	0.84

7.5 TON HEATING - LHX092S5M

Indoor Coil Air Volume 70°F Dry Bulb cfm	Air Temperature Entering Outdoor Coil									
	65°F		45°F		25°F		5°F		-15°F	
	Total Heating Capacity	Comp. Motor Input	Total Heating Capacity	Comp. Motor Input	Total Heating Capacity	Comp. Motor Input	Total Heating Capacity	Comp. Motor Input	Total Heating Capacity	Comp. Motor Input
	kBtuh	kW	kBtuh	kW	kBtuh	kW	kBtuh	kW	kBtuh	kW
2400	11.5.3	7.22	84.4	6.46	61.2	5.96	41.9	5.9	28.3	5.91
3000	117.4	6.51	85.2	5.97	61.3	5.67	42	5.76	28	5.76
2600	118.4	6.09	86	5.7	61.8	5.53	42	5.68	28.1	5.68

COOLING/HEATING RATINGS

NOTE – For Temperatures and Capacities not shown in tables, see bulletin – Cooling Unit Rating Table Correction Factor Data in Miscellaneous Engineering Data section.

8.5 TON COOLING - LHX102S5M (1 COMPRESSOR - PART LOAD)

Entering Wet Bulb Temperature	Total Air Volume	Outdoor Air Temperature Entering Outdoor Coil																			
		65°F					75°F					85°F					95°F				
		Total Cool Cap.	Comp. Motor Input	Sensible To Total Ratio (S/T)			Total Cool Cap.	Comp. Motor Input	Sensible To Total Ratio (S/T)			Total Cool Cap.	Comp. Motor Input	Sensible To Total Ratio (S/T)			Total Cool Cap.	Comp. Motor Input	Sensible To Total Ratio (S/T)		
				Dry Bulb					Dry Bulb					Dry Bulb					Dry Bulb		
cfm	kBtuh	kW	75°F	80°F	85°F	kBtuh	kW	75°F	80°F	85°F	kBtuh	kW	75°F	80°F	85°F	kBtuh	kW	75°F	80°F	85°F	
63°F	1920	49.4	1.61	0.79	0.98	1	46.5	1.94	0.81	1	1	43.4	2.31	0.83	1	1	40.5	2.72	0.86	1	1
	2400	52.1	1.59	0.86	1	1	49.1	1.93	0.89	1	1	46.3	2.3	0.92	1	1	43.3	2.7	0.96	1	1
	2880	54.6	1.58	0.93	1	1	51.5	1.92	0.97	1	1	48.4	2.29	1	1	1	45.4	2.69	1	1	1
67°F	1920	52.6	1.59	0.57	0.76	0.94	49.2	1.93	0.57	0.78	0.97	46	2.3	0.58	0.8	1	42.6	2.71	0.59	0.83	1
	2400	54.6	1.58	0.61	0.83	1	51.1	1.92	0.62	0.86	1	47.7	2.29	0.64	0.89	1	44.3	2.7	0.66	0.93	1
	2880	55.9	1.57	0.66	0.91	1	52.5	1.91	0.67	0.94	1	49	2.28	0.69	0.98	1	45.6	2.69	0.72	1	1
71°F	1920	56.2	1.57	0.37	0.55	0.73	52.6	1.91	0.36	0.56	0.75	49.2	2.28	0.36	0.57	0.78	45.9	2.69	0.35	0.58	0.8
	2400	57.8	1.56	0.38	0.6	0.81	54.5	1.9	0.38	0.61	0.84	50.9	2.28	0.38	0.63	0.87	47.3	2.69	0.38	0.65	0.9
	2880	59.3	1.55	0.41	0.65	0.88	55.7	1.89	0.39	0.67	0.91	52.1	2.27	0.4	0.69	0.95	48.4	2.68	0.4	0.71	0.99

8.5 TON COOLING - LHX102S5M (2 COMPRESSORS - PART LOAD / FULL LOAD)

Entering Wet Bulb Temperature	Total Air Volume	Outdoor Air Temperature Entering Outdoor Coil																			
		85°F					95°F					105°F					115°F				
		Total Cool Cap.	Comp. Motor Input	Sensible To Total Ratio (S/T)			Total Cool Cap.	Comp. Motor Input	Sensible To Total Ratio (S/T)			Total Cool Cap.	Comp. Motor Input	Sensible To Total Ratio (S/T)			Total Cool Cap.	Comp. Motor Input	Sensible To Total Ratio (S/T)		
				Dry Bulb					Dry Bulb					Dry Bulb					Dry Bulb		
cfm	kBtuh	kW	75°F	80°F	85°F	kBtuh	kW	75°F	80°F	85°F	kBtuh	kW	75°F	80°F	85°F	kBtuh	kW	75°F	80°F	85°F	
63°F	2040	86.1	4.83	0.68	0.82	0.95	79.9	5.57	0.69	0.83	0.96	73.3	6.39	0.69	0.85	0.97	66.4	7.33	0.71	0.88	0.99
	2550	91.3	4.82	0.73	0.89	0.99	85	5.56	0.75	0.91	1	78.1	6.38	0.76	0.94	1	71.3	7.32	0.78	0.96	1
	3060	95.3	4.82	0.79	0.95	1	89.1	5.55	0.8	0.97	1	82.5	6.38	0.82	0.98	1	75.6	7.31	0.85	1	1
67°F	2040	92.5	4.82	0.54	0.66	0.78	86.4	5.56	0.53	0.66	0.8	79.5	6.38	0.53	0.67	0.81	72.4	7.32	0.52	0.68	0.84
	2550	97.7	4.81	0.57	0.71	0.85	91.3	5.55	0.56	0.72	0.87	84.2	6.38	0.56	0.74	0.9	76.7	7.31	0.57	0.75	0.93
	3060	101.7	4.81	0.6	0.76	0.92	94.9	5.55	0.6	0.78	0.95	87.5	6.37	0.6	0.8	0.96	79.8	7.31	0.61	0.83	0.98
71°F	2040	98.8	4.81	0.4	0.52	0.64	92.5	5.55	0.39	0.52	0.64	85.8	6.37	0.38	0.52	0.65	78.6	7.31	0.36	0.51	0.66
	2550	104.4	4.8	0.41	0.55	0.69	97.8	5.55	0.4	0.56	0.7	90.8	6.37	0.39	0.55	0.71	83.1	7.3	0.38	0.56	0.73
	3060	108.4	4.79	0.43	0.58	0.74	101.4	5.53	0.42	0.59	0.76	94.2	6.37	0.41	0.6	0.77	85.7	7.3	0.4	0.6	0.8

8.5 TON COOLING - LHX102S5M (2 COMPRESSORS - FULL LOAD)

Entering Wet Bulb Temperature	Total Air Volume	Outdoor Air Temperature Entering Outdoor Coil																			
		85°F					95°F					105°F					115°F				
		Total Cool Cap.	Comp. Motor Input	Sensible To Total Ratio (S/T)			Total Cool Cap.	Comp. Motor Input	Sensible To Total Ratio (S/T)			Total Cool Cap.	Comp. Motor Input	Sensible To Total Ratio (S/T)			Total Cool Cap.	Comp. Motor Input	Sensible To Total Ratio (S/T)		
				Dry Bulb					Dry Bulb					Dry Bulb					Dry Bulb		
cfm	kBtuh	kW	75°F	80°F	85°F	kBtuh	kW	75°F	80°F	85°F	kBtuh	kW	75°F	80°F	85°F	kBtuh	kW	75°F	80°F	85°F	
63°F	2720	107	6.11	0.7	0.84	0.97	99.5	6.9	0.71	0.86	0.99	92.1	7.8	0.72	0.88	1	84.7	8.84	0.74	0.91	1
	3400	112.2	6.13	0.76	0.92	1	104.8	6.93	0.77	0.94	1	97.5	7.83	0.79	0.97	1	89.8	8.87	0.81	0.99	1
	4080	116.6	6.15	0.81	0.98	1	109.5	6.95	0.83	1	1	102.4	7.85	0.85	1	1	95	8.89	0.88	1	1
67°F	2720	113.6	6.14	0.55	0.68	0.81	107	6.94	0.55	0.69	0.82	99.3	7.84	0.55	0.7	0.85	91	8.87	0.55	0.71	0.87
	3400	119.4	6.17	0.58	0.74	0.89	111.9	6.96	0.58	0.75	0.91	104	7.86	0.59	0.77	0.93	95.8	8.89	0.59	0.79	0.97
	4080	123.6	6.19	0.61	0.79	0.95	115.8	6.98	0.62	0.81	0.98	107.6	7.88	0.63	0.83	0.99	99	8.91	0.64	0.86	1
71°F	2720	120.9	6.17	0.41	0.54	0.66	113.7	6.97	0.4	0.54	0.67	106.1	7.87	0.39	0.54	0.68	98	8.91	0.38	0.54	0.69
	3400	127	6.2	0.42	0.57	0.71	119.3	7	0.42	0.58	0.73	110.9	7.9	0.41	0.58	0.74	102.1	8.93	0.4	0.58	0.77
	4080	131	6.23	0.44	0.61	0.77	123.3	7.02	0.44	0.61	0.79	114.2	7.92	0.43	0.62	0.81	105.4	8.95	0.42	0.63	0.84

8.5 TON HEATING - LHX102S5M

Indoor Coil Air Volume 70°F Dry Bulb cfm	Air Temperature Entering Outdoor Coil									
	65°F		45°F		25°F		5°F		-15°F	
	Total Heating Capacity	Comp. Motor Input	Total Heating Capacity	Comp. Motor Input	Total Heating Capacity	Comp. Motor Input	Total Heating Capacity	Comp. Motor Input	Total Heating Capacity	Comp. Motor Input
	kBtuh	kW	kBtuh	kW	kBtuh	kW	kBtuh	kW	kBtuh	kW
2720	129.5	7.77	94.9	6.93	68.4	6.33	46.7	5.97	30.3	5.32
3400	132.2	7.11	96.2	6.47	69.1	6.07	46.9	5.85	30.5	5.19
4080	133.9	6.67	97.1	6.19	69.1	5.93	47	57.8	30.5	5.13

COOLING/HEATING RATINGS

NOTE – For Temperatures and Capacities not shown in tables, see bulletin – Cooling Unit Rating Table Correction Factor Data in Miscellaneous Engineering Data section.

10 TON COOLING - LHX120S5M (1 COMPRESSOR - PART LOAD)

Entering Wet Bulb Temperature	Total Air Volume	Outdoor Air Temperature Entering Outdoor Coil																			
		65°F					75°F					85°F					95°F				
		Total Cool Cap.	Comp. Motor Input	Sensible To Total Ratio (S/T)			Total Cool Cap.	Comp. Motor Input	Sensible To Total Ratio (S/T)			Total Cool Cap.	Comp. Motor Input	Sensible To Total Ratio (S/T)			Total Cool Cap.	Comp. Motor Input	Sensible To Total Ratio (S/T)		
				Dry Bulb					Dry Bulb					Dry Bulb					Dry Bulb		
cfm	kBtuh	kW	75°F	80°F	85°F	kBtuh	kW	75°F	80°F	85°F	kBtuh	kW	75°F	80°F	85°F	kBtuh	kW	75°F	80°F	85°F	
63°F	2110	50.2	1.6	0.82	1	1	47.4	1.94	0.84	1	1	44.7	2.31	0.87	1	1	41.8	2.73	0.9	1	1
	2640	53.2	1.58	0.9	1	1	50.3	1.92	0.93	1	1	47.5	2.3	0.96	1	1	44.5	2.71	1	1	1
	3170	55.4	1.57	0.98	1	1	52.5	1.91	1	1	1	49.6	2.28	1	1	1	46.4	2.7	1	1	1
67°F	2110	53.2	1.58	0.58	0.79	0.98	49.9	1.93	0.59	0.82	1	46.7	2.3	0.61	0.85	1	43.4	2.72	0.62	0.87	1
	2640	55.2	1.57	0.63	0.87	1	51.7	1.91	0.65	0.9	1	48.4	2.29	0.67	0.94	1	45	2.71	0.69	0.98	1
	3170	56.3	1.56	0.69	0.95	1	53.1	1.9	0.7	0.98	1	49.6	2.28	0.73	1	1	46.5	2.7	0.75	1	1
71°F	2110	56.4	1.56	0.37	0.57	0.76	53.2	1.9	0.37	0.58	0.79	49.8	2.28	0.37	0.6	0.81	46.6	2.7	0.36	0.61	0.82
	2640	58.3	1.55	0.39	0.62	0.84	54.9	1.89	0.39	0.64	0.88	51.4	2.27	0.39	0.66	0.91	48	2.69	0.4	0.68	0.92
	3170	59.6	1.54	0.41	0.67	0.92	56.2	1.89	0.41	0.7	0.96	52.6	2.27	0.42	0.72	1	49.1	2.68	0.43	0.75	0.99

10 TON COOLING - LHX120S5M (2 COMPRESSORS - PART LOAD / FULL LOAD)

Entering Wet Bulb Temperature	Total Air Volume	Outdoor Air Temperature Entering Outdoor Coil																			
		85°F					95°F					105°F					115°F				
		Total Cool Cap.	Comp. Motor Input	Sensible To Total Ratio (S/T)			Total Cool Cap.	Comp. Motor Input	Sensible To Total Ratio (S/T)			Total Cool Cap.	Comp. Motor Input	Sensible To Total Ratio (S/T)			Total Cool Cap.	Comp. Motor Input	Sensible To Total Ratio (S/T)		
				Dry Bulb					Dry Bulb					Dry Bulb					Dry Bulb		
cfm	kBtuh	kW	75°F	80°F	85°F	kBtuh	kW	75°F	80°F	85°F	kBtuh	kW	75°F	80°F	85°F	kBtuh	kW	75°F	80°F	85°F	
63°F	2400	104.4	6.47	0.68	0.81	0.91	98	7.46	0.69	0.82	0.92	91.1	8.57	0.69	0.84	0.93	84	9.84	0.71	0.85	0.96
	3000	111	6.49	0.73	0.87	0.96	104.7	7.48	0.74	0.88	0.97	97.4	8.59	0.75	0.89	0.99	90.1	9.85	0.77	0.91	1
	3600	116.9	6.51	0.77	0.91	1	109.6	7.49	0.78	0.92	1	102.7	8.6	0.8	0.94	1	94.3	9.85	0.83	0.96	1
67°F	2400	111.9	6.49	0.54	0.66	0.77	105.3	7.48	0.53	0.66	0.79	97.8	8.59	0.53	0.67	0.8	90.4	9.85	0.53	0.68	0.83
	3000	118.5	6.52	0.56	0.7	0.84	111.1	7.5	0.56	0.71	0.85	103.8	8.62	0.57	0.73	0.87	95.2	9.87	0.57	0.74	0.89
	3600	123.1	6.54	0.59	0.75	0.89	115.6	7.52	0.6	0.76	0.9	107.7	8.63	0.6	0.78	0.91	99.2	9.89	0.61	0.8	0.95
71°F	2400	119.8	6.51	0.41	0.52	0.63	112.7	7.5	0.4	0.52	0.64	104.8	8.61	0.39	0.52	0.65	96.9	9.87	0.38	0.52	0.66
	3000	126.2	6.54	0.42	0.55	0.68	118.8	7.53	0.41	0.55	0.69	111.1	8.64	0.41	0.56	0.7	102.4	9.9	0.4	0.56	0.73
	3600	131.3	6.58	0.43	0.58	0.73	123.3	7.56	0.43	0.58	0.74	114.8	8.67	0.42	0.59	0.76	106.2	9.92	0.42	0.6	0.8

10 TON COOLING - LHX120S5M (2 COMPRESSORS - FULL LOAD)

Entering Wet Bulb Temperature	Total Air Volume	Outdoor Air Temperature Entering Outdoor Coil																			
		85°F					95°F					105°F					115°F				
		Total Cool Cap.	Comp. Motor Input	Sensible To Total Ratio (S/T)			Total Cool Cap.	Comp. Motor Input	Sensible To Total Ratio (S/T)			Total Cool Cap.	Comp. Motor Input	Sensible To Total Ratio (S/T)			Total Cool Cap.	Comp. Motor Input	Sensible To Total Ratio (S/T)		
				Dry Bulb					Dry Bulb					Dry Bulb					Dry Bulb		
cfm	kBtuh	kW	75°F	80°F	85°F	kBtuh	kW	75°F	80°F	85°F	kBtuh	kW	75°F	80°F	85°F	kBtuh	kW	75°F	80°F	85°F	
63°F	3200	126.6	7.68	0.7	0.84	0.96	119	8.7	0.71	0.85	0.97	110.7	9.86	0.72	0.87	0.99	103	11.19	0.73	0.9	1
	4000	133.1	7.73	0.75	0.91	1	125.4	8.76	0.77	0.93	1	116.8	9.91	0.78	0.95	1	108.1	11.24	0.8	0.97	1
	4800	137.9	7.77	0.81	0.97	1	130	8.8	0.82	0.98	1	122.1	9.96	0.84	1	1	113.8	11.29	0.87	1	1
67°F	3200	134.4	7.74	0.55	0.68	0.8	127.2	8.77	0.55	0.69	0.82	118.9	9.93	0.55	0.7	0.84	109.7	11.25	0.56	0.71	0.89
	4000	141.1	7.8	0.58	0.73	0.88	132.9	8.82	0.58	0.74	0.9	124.4	9.99	0.59	0.76	0.92	115.2	11.3	0.6	0.78	0.97
	4800	145.9	7.85	0.62	0.78	0.94	137.4	8.87	0.62	0.8	0.97	128.5	10.03	0.63	0.82	0.98	118.7	11.34	0.64	0.85	1
71°F	3200	142.9	7.82	0.41	0.54	0.65	135	8.84	0.4	0.54	0.66	126.6	10.01	0.4	0.54	0.67	117.5	11.32	0.39	0.54	0.7
	4000	149.7	7.89	0.43	0.57	0.71	141.3	8.91	0.42	0.58	0.72	132	10.07	0.42	0.58	0.74	122.4	11.38	0.41	0.59	0.78
	4800	154.9	7.94	0.44	0.6	0.76	145.7	8.96	0.44	0.61	0.78	136.5	10.12	0.44	0.62	0.8	126.3	11.42	0.43	0.64	0.85

10 TON HEATING - LHX120S5M

Indoor Coil Air Volume 70°F Dry Bulb cfm	Air Temperature Entering Outdoor Coil									
	65°F		45°F		25°F		5°F		-15°F	
	Total Heating Capacity	Comp. Motor Input	Total Heating Capacity	Comp. Motor Input	Total Heating Capacity	Comp. Motor Input	Total Heating Capacity	Comp. Motor Input	Total Heating Capacity	Comp. Motor Input
	kBtuh	kW	kBtuh	kW	kBtuh	kW	kBtuh	kW	kBtuh	kW
3200	154.1	9.57	111.8	8.4	80.5	7.64	55.4	7.19	35.5	6.43
4000	157.3	8.7	113.1	7.8	80.9	7.31	55.5	7.04	35.6	6.33
4800	158.9	8.16	113.2	7.4	81.1	7.11	55.5	6.95	35.6	6.28

BLOWER DATA

BELT DRIVE - 7.5 TON

LHX092S5M - BASE UNIT

BLOWER TABLE INCLUDES RESISTANCE FOR BASE UNIT ONLY (NO HEAT SECTION) WITH DRY INDOOR COIL AND AIR FILTERS IN PLACE. FOR ALL UNITS ADD:

- 1 – Wet indoor coil air resistance of selected unit.
- 2 – Any factory installed options air resistance (heat section, economizer, etc.)
- 3 – Any field installed accessories air resistance (duct resistance, diffuser, etc.)

Then determine from blower table blower motor output required.

See page 25 for blower motors and drives.

See page 25 for wet coil and option/accessory air resistance data.

Minimum Air Volume Required For Use With Optional Electric Heat (Maximum Static Pressure - 2.0 in. w.g.):

7.5 kW, 15 kW, 22.5 kW, 30 kW and 45 kW - 2800 cfm

Total Air Volume cfm	Total Static Pressure – in. w.g.													
	0.2		0.4		0.6		0.8		1.0		1.2		1.4	
	RPM	BHP	RPM	BHP	RPM	BHP	RPM	BHP	RPM	BHP	RPM	BHP	RPM	BHP
1750	583	0.09	627	0.06	673	0.09	723	0.06	777	0.45	834	0.82	892	1.13
2000	593	0.11	636	0.07	682	0.10	731	0.22	784	0.60	840	0.96	898	1.26
2250	604	0.15	645	0.11	690	0.15	739	0.39	790	0.74	846	1.08	901	1.34
2500	615	0.19	655	0.15	699	0.20	747	0.55	797	0.89	851	1.20	906	1.44
2750	626	0.23	666	0.19	709	0.37	755	0.71	805	1.03	858	1.32	912	1.55
3000	637	0.27	677	0.24	719	0.55	764	0.87	813	1.18	866	1.45	920	1.67
3250	650	0.31	688	0.43	730	0.73	775	1.04	823	1.34	875	1.60	930	1.81
3500	663	0.35	700	0.63	741	0.92	786	1.22	834	1.50	886	1.76	942	1.96
3750	676	0.57	714	0.84	754	1.12	798	1.41	846	1.68	899	1.93	956	2.14

Total Air Volume cfm	Total Static Pressure – in. w.g.											
	1.6		1.8		2		2.2		2.4		2.6	
	RPM	BHP	RPM	BHP	RPM	BHP	RPM	BHP	RPM	BHP	RPM	BHP
1750	943	1.28	990	1.38	1038	1.44	1084	1.60	1131	1.79	1179	2.25
2000	948	1.38	996	1.47	1045	1.57	1092	1.71	1140	1.92	1188	2.32
2250	953	1.48	1002	1.57	1052	1.70	1100	1.86	1149	2.09	1197	2.42
2500	959	1.58	1009	1.68	1059	1.83	1108	2.01	1158	2.26	1206	2.52
2750	966	1.70	1017	1.81	1067	1.97	1117	2.17	1166	2.44	1215	2.71
3000	975	1.82	1026	1.96	1076	2.13	1126	2.35	1176	2.63	1225	2.92
3250	985	1.97	1036	2.12	1086	2.31	1136	2.54	1186	2.83	1235	3.13
3500	997	2.14	1048	2.31	1097	2.51	1147	2.75	1196	3.04	1245	3.35
3750	1010	2.32	1060	2.51	1109	2.72	1158	2.98	1207	3.27	1255	3.58

BLOWER DATA

BELT DRIVE - 8.5 | 10 TON

LHX102S5M, LHX120S5M - BASE UNIT

BLOWER TABLE INCLUDES RESISTANCE FOR BASE UNIT ONLY (NO HEAT SECTION) WITH DRY INDOOR COIL AND AIR FILTERS IN PLACE. FOR ALL UNITS ADD:

- 1 – Wet indoor coil air resistance of selected unit.
- 2 – Any factory installed options air resistance (heat section, economizer, etc.)
- 3 – Any field installed accessories air resistance (duct resistance, diffuser, etc.)

Then determine from blower table blower motor output required.

See page 25 for blower motors and drives.

See page 25 for wet coil and option/accessory air resistance data.

Minimum Air Volume Required For Use With Optional Electric Heat (Maximum Static Pressure - 2.0 in. w.g.):

7.5 kW, 15 kW, 22.5 kW, 30 kW and 45 kW - 2800 cfm; 60 kW - 4000 cfm

Total Air Volume cfm	Total Static Pressure – in. w.g.													
	0.2		0.4		0.6		0.8		1.0		1.2		1.4	
	RPM	BHP	RPM	BHP	RPM	BHP	RPM	BHP	RPM	BHP	RPM	BHP	RPM	BHP
1750	480	0.19	548	0.39	618	0.57	689	0.70	758	0.81	824	0.92	885	1.07
2000	492	0.27	560	0.47	629	0.64	700	0.77	768	0.88	832	1.00	892	1.16
2250	505	0.35	573	0.55	643	0.72	713	0.85	780	0.97	842	1.10	900	1.25
2500	520	0.45	588	0.64	658	0.81	727	0.94	793	1.07	853	1.21	909	1.37
2750	536	0.55	604	0.74	674	0.91	743	1.05	806	1.19	865	1.34	919	1.50
3000	553	0.66	622	0.85	692	1.02	760	1.17	821	1.32	878	1.48	930	1.64
3250	572	0.77	641	0.98	712	1.15	778	1.32	837	1.48	892	1.64	942	1.81
3500	592	0.90	663	1.12	733	1.31	798	1.48	854	1.65	907	1.82	955	1.99
3750	614	1.04	687	1.28	756	1.48	818	1.66	872	1.83	922	2.01	969	2.19
4000	639	1.22	712	1.47	780	1.67	838	1.85	890	2.03	939	2.22	983	2.42
4250	666	1.42	740	1.68	804	1.88	859	2.06	909	2.25	956	2.45	998	2.67
4500	697	1.65	769	1.91	829	2.10	881	2.28	929	2.48	973	2.71	1013	2.95
4750	729	1.91	798	2.15	854	2.34	903	2.53	948	2.75	991	3.00	1030	3.27
5000	763	2.18	826	2.41	878	2.60	925	2.81	968	3.05	1009	3.33	1046	3.61

Total Air Volume cfm	Total Static Pressure – in. w.g.											
	1.6		1.8		2		2.2		2.4		2.6	
	RPM	BHP	RPM	BHP	RPM	BHP	RPM	BHP	RPM	BHP	RPM	BHP
1750	941	1.23	992	1.40	1039	1.55	1084	1.70	1128	1.85	1156	2.08
2000	946	1.32	995	1.48	1041	1.65	1085	1.81	1127	1.97	1160	2.13
2250	952	1.42	999	1.59	1044	1.76	1087	1.93	1127	2.10	1164	2.27
2500	959	1.54	1005	1.71	1048	1.89	1089	2.07	1127	2.25	1166	2.42
2750	968	1.67	1012	1.86	1053	2.04	1092	2.23	1129	2.41	1167	2.60
3000	977	1.83	1020	2.02	1059	2.21	1096	2.41	1133	2.60	1170	2.79
3250	988	2.00	1028	2.20	1066	2.41	1102	2.61	1138	2.81	1174	3.01
3500	999	2.19	1038	2.41	1074	2.63	1109	2.84	1144	3.04	1180	3.24
3750	1010	2.41	1048	2.64	1084	2.87	1118	3.09	1152	3.29	1188	3.50
4000	1023	2.65	1060	2.90	1095	3.14	1128	3.36	1162	3.57	1198	3.77
4250	1036	2.92	1072	3.18	1106	3.42	1139	3.65	1172	3.86	1208	4.07
4500	1050	3.22	1085	3.48	1118	3.73	1151	3.96	1184	4.17	1221	4.39
4750	1065	3.55	1099	3.81	1132	4.06	1164	4.29	1198	4.51	1235	4.74
5000	1081	3.90	1114	4.17	1146	4.42	1178	4.65	1212	4.87	1250	5.09

BLOWER DATA

FACTORY INSTALLED BELT DRIVE KIT SPECIFICATIONS

Nominal HP	Maximum HP	Drive Kit Number	RPM Range
2	2.3	1	590 - 890
2	2.3	2	800 - 1105
2	2.3	3	795 - 1195
3	3.45	4	730 - 970
3	3.45	5	940 - 1200
3	3.45	6	1015 - 1300
5	5.75	10	900 - 1135
5	5.75	11	1050 - 1335

NOTE - Using total air volume and system static pressure requirements determine from blower performance tables rpm and motor output required. Maximum usable output of motors furnished are shown. In Canada, nominal motor output is also maximum usable motor output. If motors of comparable output are used, be sure to keep within the service factor limitations outlined on the motor nameplate.

NOTE – Motor service factor limit - 1.0.

POWER EXHAUST FAN PERFORMANCE

Return Air System Static Pressure	Air Volume Exhausted
in. w.g.	cfm
0	3175
0.05	2955
0.10	2685
0.15	2410
0.20	2165
0.25	1920
0.30	1420
0.35	1200

FACTORY INSTALLED OPTIONS/FIELD INSTALLED ACCESSORY AIR RESISTANCE - in. w.g.

Air Volume cfm	Wet Indoor Coil		Electric Heat	Economizer	Filters			Return Air Adaptor Plate
	092	102,120			MERV 8	MERV 13	MERV 16	
1750	0.03	0.04	0.03	0.05	0.01	0.03	0.06	0.00
2000	0.04	0.05	0.03	0.06	0.01	0.03	0.08	0.00
2250	0.05	0.06	0.04	0.08	0.01	0.04	0.09	0.00
2500	0.05	0.07	0.04	0.11	0.01	0.05	0.10	0.00
2750	0.06	0.08	0.05	0.12	0.02	0.05	0.11	0.00
3000	0.07	0.10	0.06	0.13	0.02	0.06	0.12	0.02
3250	0.08	0.11	0.06	0.15	0.02	0.06	0.13	0.02
3500	0.09	0.12	0.09	0.15	0.03	0.07	0.15	0.04
3750	0.10	0.14	0.09	0.15	0.03	0.08	0.16	0.07
4000	0.11	0.15	0.09	0.19	0.04	0.08	0.17	0.09
4250	0.13	0.17	0.13	0.19	0.04	0.09	0.19	0.11
4500	0.14	0.19	0.14	0.22	0.04	0.09	0.20	0.12
4750	0.15	0.20	0.17	0.25	0.05	0.10	0.21	0.16
5000	0.16	0.22	0.20	0.29	0.06	0.10	0.23	0.18
5250	0.17	0.24	0.22	0.32	0.06	0.11	0.24	0.19
5500	0.19	0.25	0.25	0.34	0.07	0.12	0.25	0.22
5750	0.20	0.27	0.31	0.45	0.07	0.12	0.27	0.25
6000	0.22	0.29	0.33	0.52	0.08	0.13	0.28	0.27

BLOWER DATA

CEILING DIFFUSERS AIR RESISTANCE - in. w.g.

Size	RTD11 Step-Down Diffuser				FD11 Flush Diffuser
	Air Volume cfm	2 Ends Open	1 Side, 2 Ends Open	All Ends & Sides Open	
092	2400	0.21	0.18	0.15	0.14
	2600	0.24	0.21	0.18	0.17
	2800	0.27	0.24	0.21	0.20
	3000	0.32	0.29	0.25	0.25
	3200	0.41	0.37	0.32	0.31
	3400	0.50	0.45	0.39	0.37
	3600	0.61	0.54	0.48	0.44
	3800	0.73	0.63	0.57	0.51
102 & 120	3600	0.36	0.28	0.23	0.15
	3800	0.40	0.32	0.26	0.18
	4000	0.44	0.36	0.29	0.21
	4200	0.49	0.40	0.33	0.24
	4400	0.54	0.44	0.37	0.27
	4600	0.60	0.49	0.42	0.31
	4800	0.65	0.53	0.46	0.35
	5000	0.69	0.58	0.50	0.39

CEILING DIFFUSER AIR THROW DATA

Size	Air Volume	¹ Effective Throw Range	
		RTD11 Step-Down	FD11 Flush
	cfm	ft.	ft.
092	2600	24 - 29	19 - 24
	2800	25 - 30	20 - 28
	3000	27 - 33	21 - 29
	3200	28 - 35	22 - 29
	3400	30 - 37	22 - 30
102 & 120	3600	25 - 33	22 - 29
	3800	27 - 35	22 - 30
	4000	29 - 37	24 - 33
	4200	32 - 40	26 - 35
	4400	34 - 42	28 - 37

¹ Throw is the horizontal or vertical distance an air stream travels on leaving the outlet or diffuser before the maximum velocity is reduced to 50 ft. per minute. Four sides open.

ELECTRICAL/ELECTRIC HEAT DATA

7.5 TON

Model		LHX092S5M								
¹ Voltage - 60Hz		208/230V - 3 Ph			460V - 3 Ph			575V - 3 Ph		
Compressor 1 (Non-Inverter)	Rated Load Amps	11.9			6.8			4.8		
	Locked Rotor Amps	112			61.8			39		
Compressor 2 (Non-Inverter)	Rated Load Amps	12.8			6			5.8		
	Locked Rotor Amps	120.4			49.4			41		
Outdoor Fan Motors (2)	Full Load Amps (2 Non-ECM)	3			1.5			1.2		
	Total	6			3			2.4		
Power Exhaust (1) 0.33 HP	Full Load Amps	2.4			1.3			1		
Service Outlet 115V GFI (amps)		15			15			20		
Indoor Blower Motor	HP	2	3	5	2	3	5	2	3	5
	Full Load Amps	7.5	10.6	16.7	3.4	4.8	7.6	2.7	3.9	6.1
² Maximum Overcurrent Protection (MOCP)	Unit Only	50	50	60	25	25	30	20	20	25
	With (1) 0.33 HP Power Exhaust	50	50	70	25	30	30	20	25	25
³ Minimum Circuit Ampacity (MCA)	Unit Only	42	45	52	21	23	26	18	19	21
	With (1) 0.33 HP Power Exhaust	44	47	54	23	24	27	19	20	22

ELECTRIC HEAT DATA

Electric Heat Voltage			208V	240V	208V	240V	208V	240V	480V	480V	480V	600V	600V	600V
² Maximum Overcurrent Protection (MOCP)	Unit+ Electric Heat	7.5 kW	70	70	70	70	80	80	35	35	40	30	30	30
		15 kW	90	90	90	90	100	100	45	45	50	40	40	40
		22.5 kW	110	110	110	125	125	125	60	60	60	45	50	50
		30 kW	125	150	125	150	150	150	70	70	80	60	60	60
		45 kW	175	200	175	200	175	200	90	90	100	80	80	80
³ Minimum Circuit Ampacity (MCA)	Unit+ Electric Heat	7.5 kW	61	64	65	68	72	75	33	34	37	27	28	30
		15 kW	81	87	84	90	91	97	44	45	48	36	37	39
		22.5 kW	101	110	104	113	111	120	55	57	60	45	46	48
		30 kW	120	132	123	135	130	142	67	68	71	54	55	57
		45 kW	159	177	162	180	169	187	89	90	93	72	73	75
² Maximum Overcurrent Protection (MOCP)	Unit+ Electric Heat and (1) 0.33 HP Power Exhaust	7.5 kW	70	70	70	70	80	80	35	35	40	30	30	35
		15 kW	90	90	90	100	100	100	45	50	50	40	40	40
		22.5 kW	110	125	110	125	125	125	60	60	70	50	50	50
		30 kW	125	150	150	150	150	150	70	70	80	60	60	60
		45 kW	175	200	175	200	175	200	90	100	100	80	80	80
³ Minimum Circuit Ampacity (MCA)	Unit+ Electric Heat and (1) 0.33 HP Power Exhaust	7.5 kW	64	67	67	70	74	77	34	35	38	28	29	31
		15 kW	83	89	86	93	94	100	45	47	50	37	38	40
		22.5 kW	103	112	106	115	113	122	57	58	61	46	47	49
		30 kW	122	135	126	138	133	145	68	69	72	55	56	58
		45 kW	162	180	165	183	172	190	90	92	95	73	74	76

ELECTRICAL ACCESSORIES

Disconnect	7.5 kW	54W56	54W56	54W56
	15 kW	54W57	54W56	54W56
	22.5 kW	54W57	54W56	54W56
	30 kW	54W57	54W56	54W56
	45 kW	Not Available	54W57	54W56

Disconnects - 54W56 - 80A
54W57 - 150A

NOTE - All units have a minimum Short Circuit Current Rating (SCCR) of 5000 amps.

¹ Extremes of operating range are plus and minus 10% of line voltage.

² HACR type breaker or fuse.

³ Refer to National or Canadian Electrical Code manual to determine wire, fuse and disconnect size requirements.

ELECTRICAL/ELECTRIC HEAT DATA

8.5 TON

Model		LHX102S5M								
¹ Voltage - 60Hz		208/230V - 3 Ph			460V - 3 Ph			575V - 3 Ph		
Compressor 1 (Non-Inverter)	Rated Load Amps	13.8			6.9			5.8		
	Locked Rotor Amps	150			58			47.8		
Compressor 2 (Non-Inverter)	Rated Load Amps	12.2			6.4			5.1		
	Locked Rotor Amps	120.4			50			41		
Outdoor Fan Motors (2)	Full Load Amps (2 Non-ECM)	3			1.5			1.2		
	Total	6			3			2.4		
Power Exhaust (1) 0.33 HP	Full Load Amps	2.4			1.3			1		
Service Outlet 115V GFI (amps)		15			15			20		
Indoor Blower Motor	HP	2	3	5	2	3	5	2	3	5
	Full Load Amps	7.5	10.6	16.7	3.4	4.8	7.6	2.7	3.9	6.1
² Maximum Overcurrent Protection (MOCP)	Unit Only	50	50	60	25	25	30	20	20	25
	With (1) 0.33 HP Power Exhaust	50	60	70	25	30	30	20	25	25
³ Minimum Circuit Ampacity (MCA)	Unit Only	43	47	53	22	23	26	18	19	21
	With (1) 0.33 HP Power Exhaust	46	49	56	23	25	28	19	20	22

ELECTRIC HEAT DATA

Electric Heat Voltage			208V	240V	208V	240V	208V	240V	480V	480V	480V	600V	600V	600V
² Maximum Overcurrent Protection (MOCP)	Unit+ Electric Heat	7.5 kW	70	70	70	70	80	80	35	35	40	30	30	30
		15 kW	90	90	90	100	100	100	45	50	50	40	40	40
		22.5 kW	110	125	110	125	125	125	60	60	60	45	50	50
		30 kW	125	150	125	150	150	150	70	70	80	60	60	60
		45 kW	175	200	175	200	175	200	90	100	100	80	80	80
³ Minimum Circuit Ampacity (MCA)	Unit+ Electric Heat	7.5 kW	63	66	66	69	73	76	33	35	38	27	28	30
		15 kW	83	89	86	92	92	98	44	46	49	36	37	39
		22.5 kW	102	111	105	114	112	121	56	57	60	45	46	48
		30 kW	122	134	125	137	132	144	67	68	71	54	55	58
		45 kW	161	179	164	182	171	189	90	91	94	72	73	76
² Maximum Overcurrent Protection (MOCP)	Unit+ Electric Heat and (1) 0.33 HP Power Exhaust	7.5 kW	70	70	70	80	80	90	35	40	40	30	30	35
		15 kW	90	100	90	100	100	110	50	50	50	40	40	40
		22.5 kW	110	125	110	125	125	125	60	60	70	50	50	50
		30 kW	125	150	150	150	150	150	70	70	80	60	60	60
		45 kW	175	200	175	200	175	200	100	100	100	80	80	80
³ Minimum Circuit Ampacity (MCA)	Unit+ Electric Heat and (1) 0.33 HP Power Exhaust	7.5 kW	65	68	68	72	75	78	35	36	39	28	29	31
		15 kW	85	91	88	94	95	101	46	47	50	37	38	40
		22.5 kW	104	114	108	117	114	123	57	58	61	46	47	49
		30 kW	124	136	127	139	134	146	68	70	73	55	56	59
		45 kW	163	181	166	184	173	191	91	92	95	73	74	77

ELECTRICAL ACCESSORIES

Disconnect	7.5 kW	54W56			54W56			54W56		
	15 kW	54W57			54W56			54W56		
	22.5 kW	54W57			54W56			54W56		
	30 kW	54W57			54W56			54W56		
	45 kW	Not Available			54W57			54W56		

Disconnects - 54W56 - 80A
54W57 - 150A

NOTE - All units have a minimum Short Circuit Current Rating (SCCR) of 5000 amps.

¹ Extremes of operating range are plus and minus 10% of line voltage.

² HACR type breaker or fuse.

³ Refer to National or Canadian Electrical Code manual to determine wire, fuse and disconnect size requirements.

ELECTRICAL/ELECTRIC HEAT DATA

10 TON

Model		LHX120S5M								
¹ Voltage - 60Hz		208/230V - 3 Ph			460V - 3 Ph			575V - 3 Ph		
Compressor 1 (Non-Inverter)	Rated Load Amps	13.8			6.9			5.8		
	Locked Rotor Amps	150			58			47.8		
Compressor 2 (Non-Inverter)	Rated Load Amps	21.2			9.1			7.7		
	Locked Rotor Amps	156.5			74.8			47.8		
Outdoor Fan Motors (2)	Full Load Amps (2 Non-ECM)	3			1.5			1.2		
	Total	6			3			2.4		
Power Exhaust (1) 0.33 HP	Full Load Amps	2.4			1.3			1		
Service Outlet 115V GFI (amps)		15			15			20		
Indoor Blower Motor	HP	2	3	5	2	3	5	2	3	5
	Full Load Amps	7.5	10.6	16.7	3.4	4.8	7.6	2.7	3.9	6.1
² Maximum Overcurrent Protection (MOCP)	Unit Only	70	70	80	30	35	35	25	25	30
	With (1) 0.33 HP Power Exhaust	70	80	80	35	35	35	25	30	30
³ Minimum Circuit Ampacity (MCA)	Unit Only	54	57	63	25	27	29	21	22	24
	With (1) 0.33 HP Power Exhaust	57	60	66	26	28	31	22	23	25

ELECTRIC HEAT DATA

Electric Heat Voltage			208V	240V	208V	240V	208V	240V	480V	480V	480V	600V	600V	600V
² Maximum Overcurrent Protection (MOCP)	Unit+ Electric Heat	15 kW	100	110	100	110	110	110	50	50	60	40	40	45
		22.5 kW	125	125	125	125	125	150	60	60	70	50	50	60
		30 kW	150	150	150	150	150	175	70	80	80	60	60	70
		45 kW	175	200	175	200	200	200	100	100	100	80	80	80
		60 kW	200	200	200	225	200	225	100	100	110	80	80	90
³ Minimum Circuit Ampacity (MCA)	Unit+ Electric Heat	15 kW	93	99	96	103	103	109	48	49	52	39	40	42
		22.5 kW	113	122	116	125	122	131	59	60	63	48	49	51
		30 kW	132	145	136	148	142	154	70	72	74	57	58	61
		45 kW	172	190	175	193	181	199	93	94	97	75	76	79
		60 kW	179	199	182	202	189	208	97	99	102	79	80	82
² Maximum Overcurrent Protection (MOCP)	Unit+ Electric Heat and (1) 0.33 HP Power Exhaust	15 kW	100	110	110	110	110	125	50	50	60	40	45	45
		22.5 kW	125	125	125	150	125	150	60	70	70	50	50	60
		30 kW	150	150	150	150	150	175	80	80	80	60	60	70
		45 kW	175	200	200	200	200	225	100	100	100	80	80	80
		60 kW	200	225	200	225	200	225	100	100	110	80	90	90
³ Minimum Circuit Ampacity (MCA)	Unit+ Electric Heat and (1) 0.33 HP Power Exhaust	15 kW	96	102	99	105	105	111	49	50	53	40	41	43
		22.5 kW	115	124	118	127	125	134	60	62	65	49	50	52
		30 kW	135	147	138	150	144	156	72	73	76	58	59	62
		45 kW	174	192	177	195	183	201	94	96	98	76	77	80
		60 kW	182	201	185	204	191	210	99	100	103	80	81	83

ELECTRICAL ACCESSORIES

Disconnect	15 kW	54W57			54W56			54W56		
	22.5 kW	54W57			54W56			54W56		
	30 kW	54W57			54W56			54W56		
	45 kW	Not Available			54W57			54W56		
	60 kW	Not Available			54W57			54W56		

Disconnects - 54W56 - 80A
54W57 - 150A

NOTE - All units have a minimum Short Circuit Current Rating (SCCR) of 5000 amps.

¹ Extremes of operating range are plus and minus 10% of line voltage.

² HACR type breaker or fuse.

³ Refer to National or Canadian Electrical Code manual to determine wire, fuse and disconnect size requirements.

ELECTRIC HEAT CAPACITIES

Volts Input	7.5 kW			15 kW			22.5 kW			30 kW			45 kW			60 kW		
	kW Input	Btuh Output	No. of Stages	kW Input	Btuh Output	No. of Stages	kW Input	Btuh Output	No. of Stages	kW Input	Btuh Output	No. of Stages	kW Input	Btuh Output	No. of Stages	kW Input	Btuh Output	No. of Stages
208	5.6	19,100	1	11.3	38,600	1	16.9	57,700	1	22.5	76,800	1	33.8	115,300	1	45.0	153,600	1
220	6.3	21,500	1	12.6	43,000	1	18.9	64,500	1	25.2	86,000	1	37.8	129,000	1	50.4	172,000	1
230	6.9	23,600	1	13.8	47,100	1	20.7	70,700	1	27.5	93,900	1	41.3	141,000	1	55.1	188,000	1
240	7.5	25,600	1	15.0	51,200	1	22.5	76,800	1	30.0	102,400	1	45.0	153,600	1	60.0	204,800	1
440	6.9	21,500	1	12.6	43,000	1	18.9	64,500	1	25.2	86,000	1	37.8	129,000	1	50.4	172,000	1
460	6.9	23,600	1	13.8	47,100	1	20.7	70,700	1	27.5	93,900	1	41.3	141,000	1	55.1	188,000	1
480	7.5	25,600	1	15.0	51,200	1	22.5	76,800	1	30.0	102,400	1	45.0	153,600	1	60.0	204,800	1
550	6.3	21,500	1	12.6	43,000	1	18.9	64,500	1	25.2	86,000	1	37.8	129,000	1	50.4	172,000	1
575	6.9	23,600	1	13.8	47,100	1	20.7	70,700	1	27.5	93,900	1	41.3	141,000	1	55.1	188,000	1
600	7.5	25,600	1	15.0	51,200	1	22.5	76,800	1	30.0	102,400	1	45.0	153,600	1	60.0	204,800	1

FIELD WIRING NOTES

- For use with copper wiring only
- Field wiring not furnished
- All wiring must conform to NEC or CEC and local electrical codes
- For specific wiring information, please refer to the installation instructions

UNIT CLEARANCES

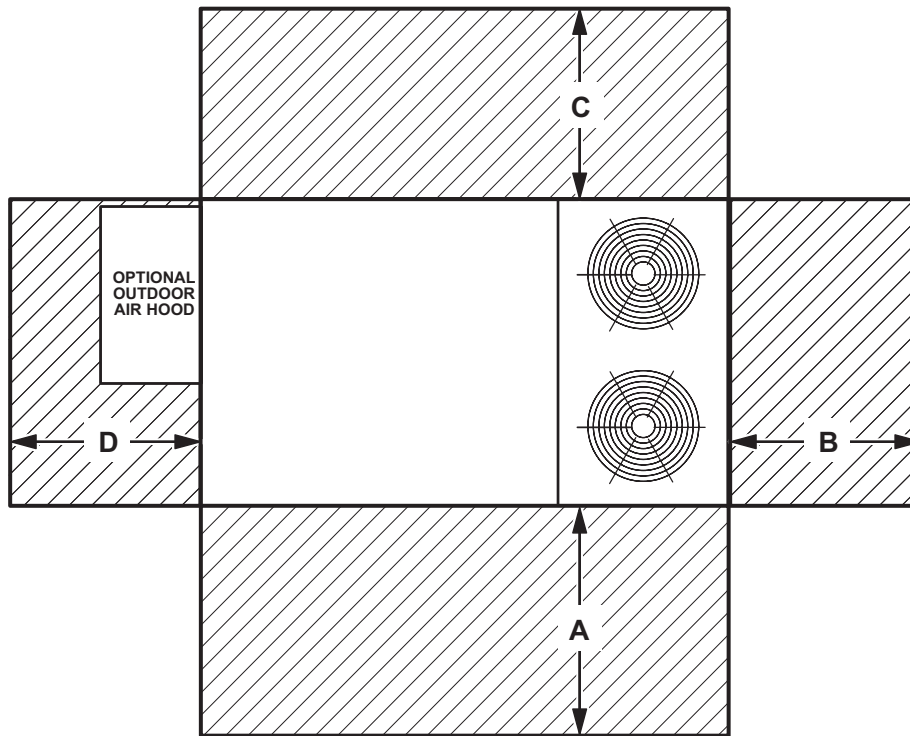

¹ Unit Clearance	A		B		C		D		Top Clearance
	in.	mm	in.	mm	in.	mm	in.	mm	
Service Clearance	60	1524	36	914	36	914	60	1524	Unobstructed
Minimum Operation Clearance	36	914	36	914	36	914	36	914	

NOTE - Entire perimeter of unit base requires support when elevated above the mounting surface.

¹ Service Clearance - Required for removal of serviceable parts.

Minimum Operation Clearance - Required clearance for proper unit operation.

OUTDOOR SOUND DATA

Size	Octave Band Sound Power Levels dBA, re 10 ⁻¹² Watts Center Frequency - Hz							¹ Sound Rating Number (dBA)
	125	250	500	1000	2000	4000	8000	
092, 102 and 120	76	79	84	83	79	73	66	88

Note - The octave sound power data does not include tonal corrections.

¹ Sound Rating Number according to AHRI Standard 270-95 or AHRI Standard 370-2001 (includes pure tone penalty). Sound Rating Number is the overall A-Weighted Sound Power Level, (L_{wa}), dB (100 Hz to 10,000 Hz).

WEIGHT DATA				UNIT
Size	Net		Shipping	
	lbs.	kg	lbs.	kg
092 Base Unit	1052	477	1137	516
092 Max. Unit	1209	548	1294	587
102 Base Unit	1084	492	1169	530
102 Max. Unit	1241	563	1326	601
120 Base Unit	1150	522	1235	560
120 Max. Unit	1314	596	1399	635

Max. Unit - The unit with ALL INTERNAL OPTIONS Installed. (Economizer, Standard Static Power Exhaust Fans, Controls, etc.). Does not include accessories external to unit.

FACTORY / FIELD INSTALLED OPTIONS AND ACCESSORIES - NET WEIGHTS

Description	lbs.	kg	
ECONOMIZER / OUTDOOR AIR / POWER EXHAUST			
Economizer			
Economizer Dampers	56	26	
Barometric Relief Dampers (downflow)	9	4	
Barometric Relief Dampers (low profile horizontal)	20	9	
Outdoor Air Hood (downflow)	21	10	
Outdoor Air Dampers			
Motorized	10	5	
Manual	10	5	
Power Exhaust	31	14	
ELECTRIC HEAT			
7.5 kW	50	23	
15 kW	50	23	
22.5 kW	57	26	
30 kW	57	26	
45 kW	59	27	
60 kW	43	20	
COIL/HAIL GUARDS			
All models	21	10	
ROOF CURBS			
Hybrid Roof Curbs, Downflow			
8 in. height	103	47	
14 in. height	125	57	
18 in. height	147	67	
24 in. height	169	77	
Adjustable Pitch Curb, Downflow			
14 in. height	169	77	
CEILING DIFFUSERS			
Step-Down	RTD11-95S	118	54
	RTD11-135S	135	61
	RTD11-185S	168	76
Flush	FD11-95S	118	54
	FD11-135S	135	61
	FD11-185S	168	76
Transitions	C1DIFF30B-1	30	14
	C1DIFF31B-1	32	15
	C1DIFF32B-1	36	16

DIMENSIONS

UNIT

Size	CORNER WEIGHTS														CENTER OF GRAVITY									
	AA				BB				CC				DD				EE				FF			
	Base		Max.		Base		Max.		Base		Max.		Base		Max.		Base		Max.		Base		Max.	
	lbs.	kg	lbs.	kg	lbs.	kg	lbs.	kg	lbs.	kg	lbs.	kg	lbs.	kg	in.	mm	in.	mm	in.	mm	in.	mm	in.	mm
092	264	120	310	140	237	108	271	123	258	117	290	131	293	133	339	154	46.5	1181	45.5	1156	24.5	622	25.5	648
102	272	123	318	144	244	111	278	126	266	121	297	135	302	137	348	158	46.5	1181	45.5	1156	24.5	622	25.5	648
120	284	129	333	151	264	120	298	135	288	131	320	145	315	143	363	165	46.5	1181	45.5	1156	24.5	622	25.5	648

Base Unit - The unit with NO OPTIONS.

Max. Unit - The unit with ALL OPTIONS Installed (Economizer, etc.).

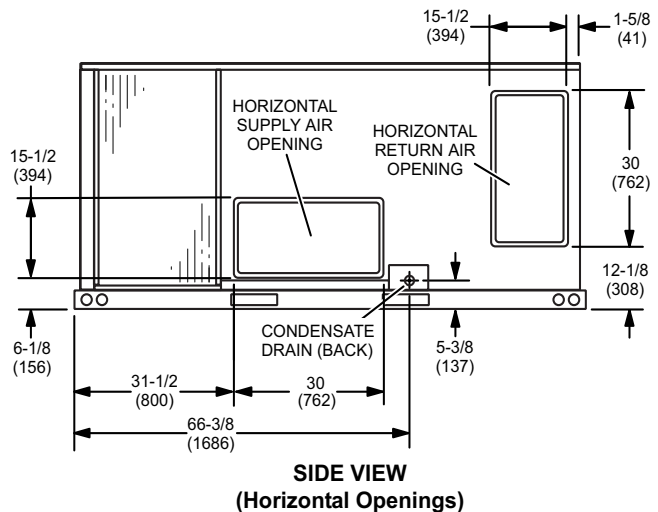
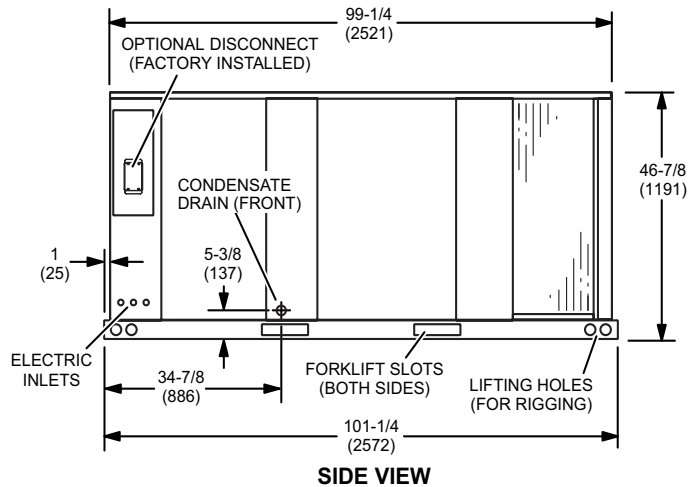
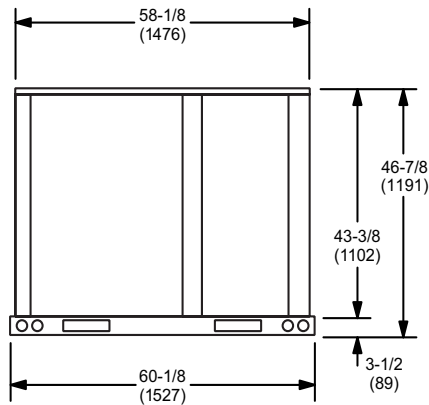
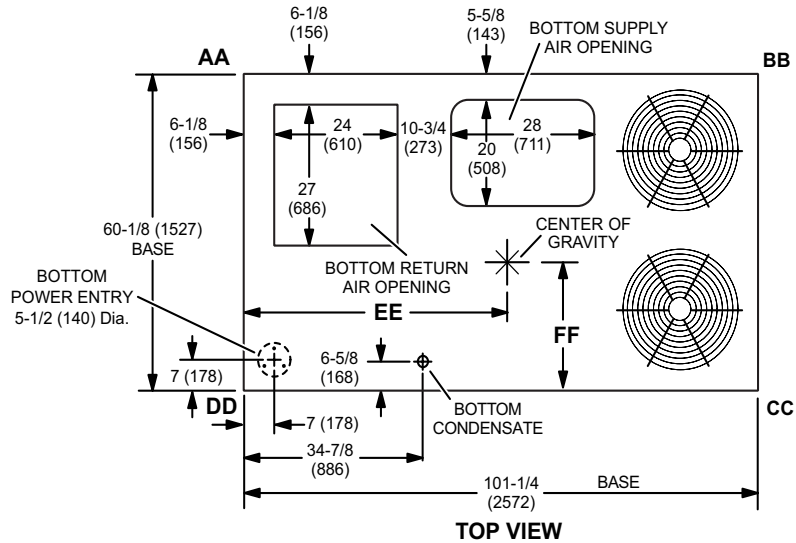

OUTDOOR AIR HOOD DETAIL

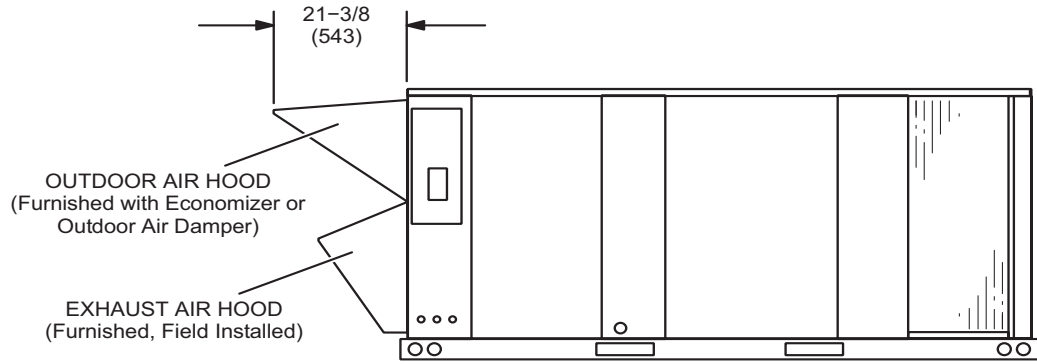

HORIZONTAL ECONOMIZER APPLICATION

(With Furnished Barometric Relief Dampers and Optional Horizontal Discharge Kit - Required)

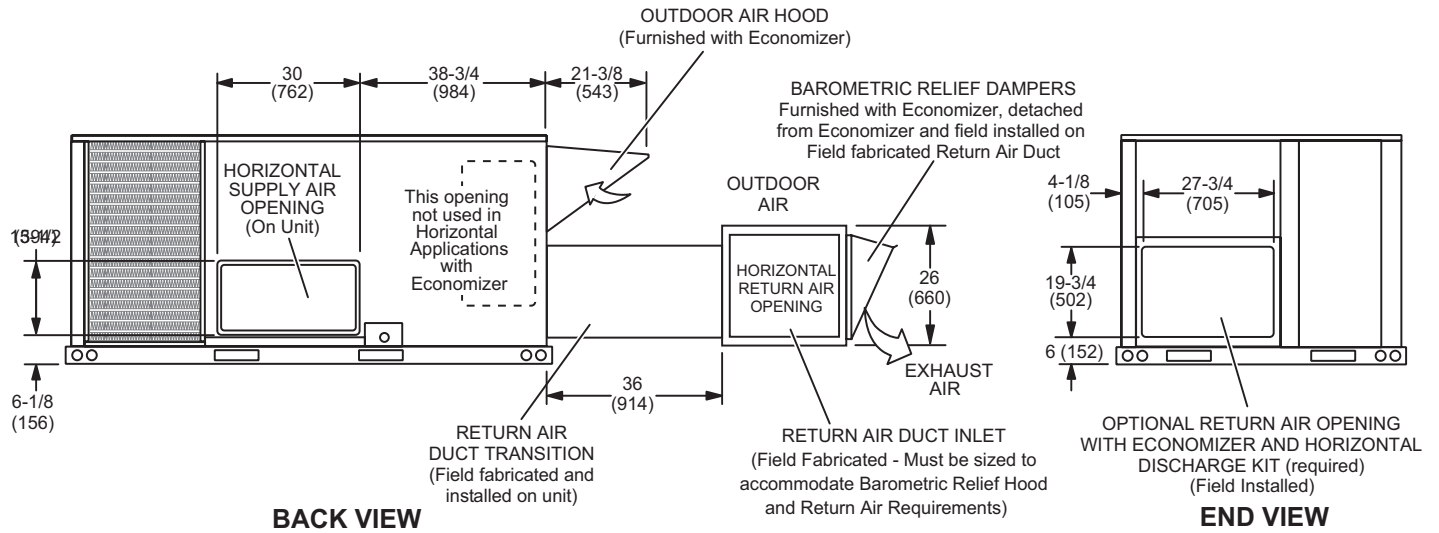
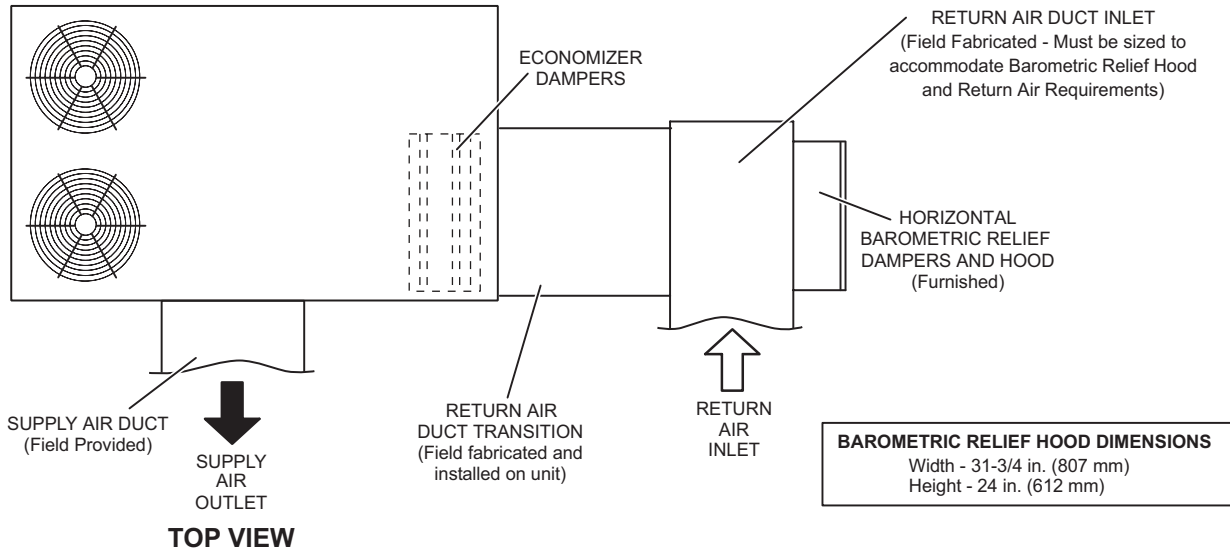

NOTE - Return Air Duct and Transition must be supported.

BAROMETRIC RELIEF DAMPERS
(Furnished with Economizer)

(Field installed in horizontal return air duct adjacent to unit)

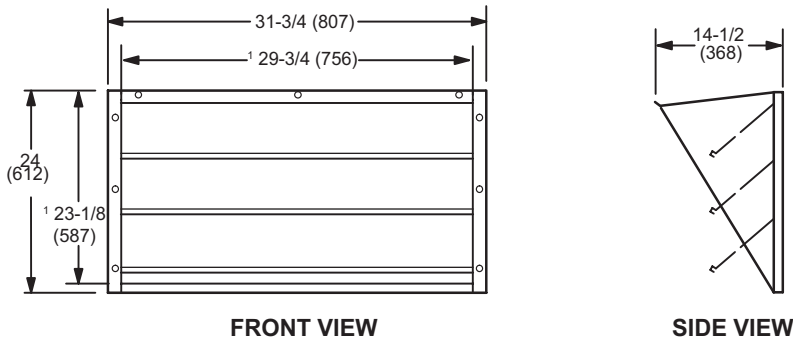

¹ NOTE - Opening size required in return air duct.

HORIZONTAL ECONOMIZER APPLICATION

(with Optional Low Profile Horizontal Barometric Relief Dampers and Horizontal Discharge Kit - Required)

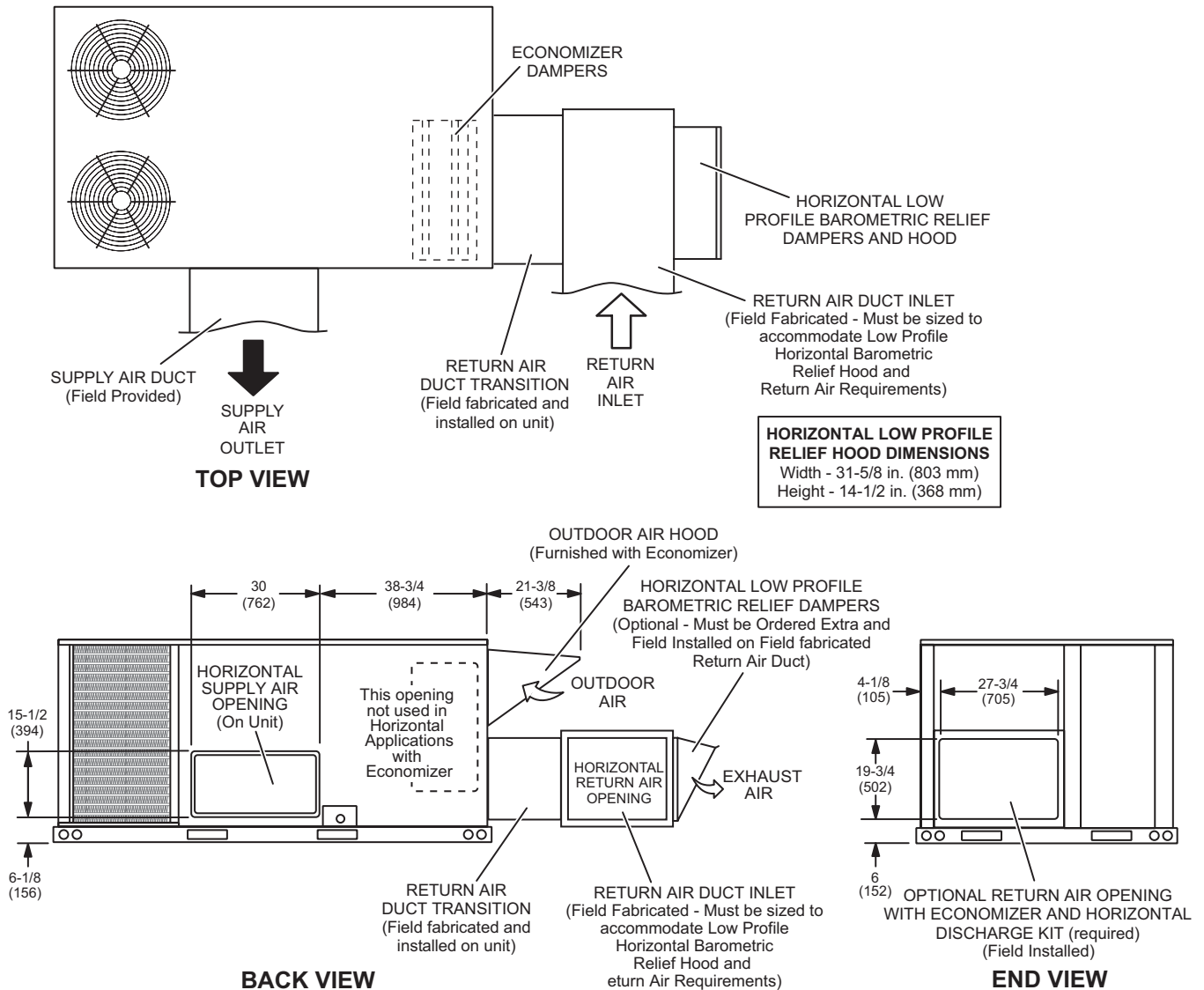

NOTE - Return Air Duct and Transition must be supported.

HORIZONTAL LOW PROFILE BAROMETRIC RELIEF DAMPERS

(Field installed in horizontal return air duct adjacent to unit)

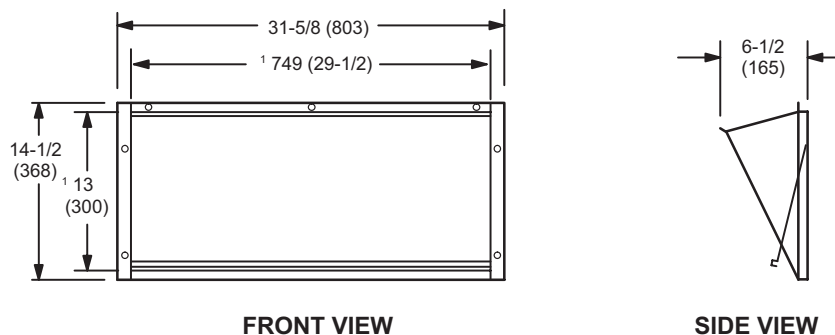

¹ NOTE - Opening size required in return air duct.

HYBRID ROOF CURBS - DOUBLE DUCT OPENING

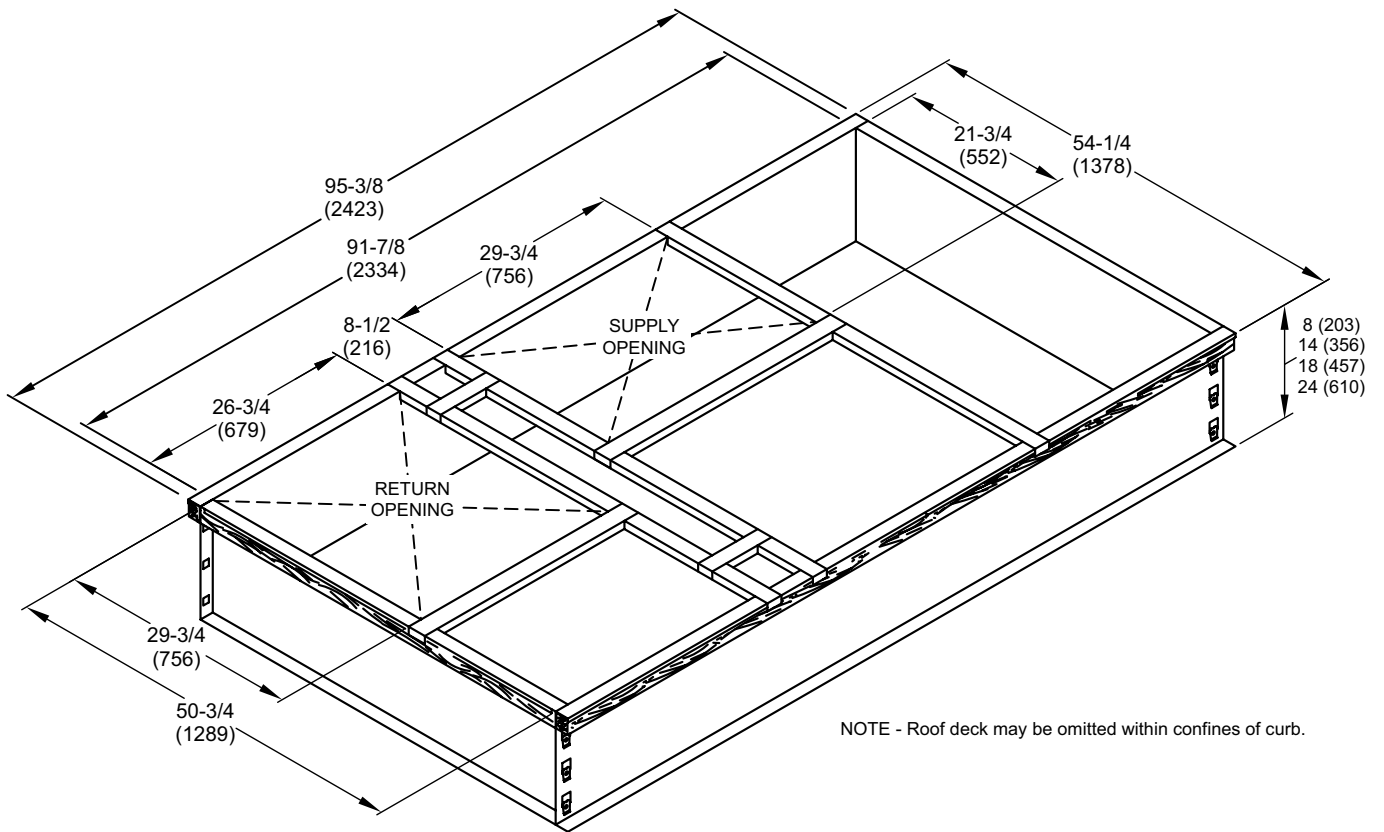

NOTE - Roof deck may be omitted within confines of curb.

TYPICAL FLASHING DETAIL FOR ROOF CURB

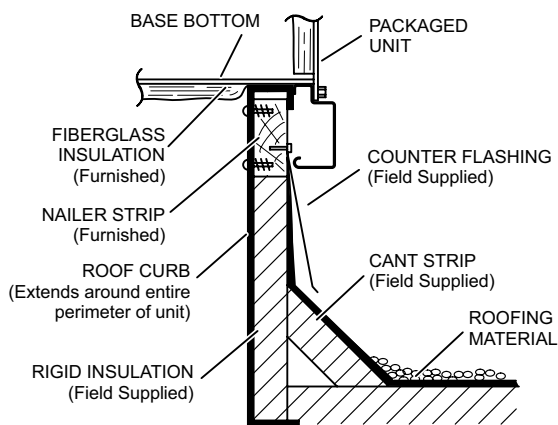

DETAIL ROOF CURB

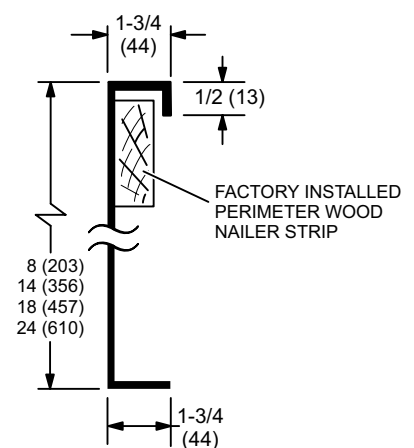

ADJUSTABLE PITCH CURBS - DOUBLE DUCT OPENING

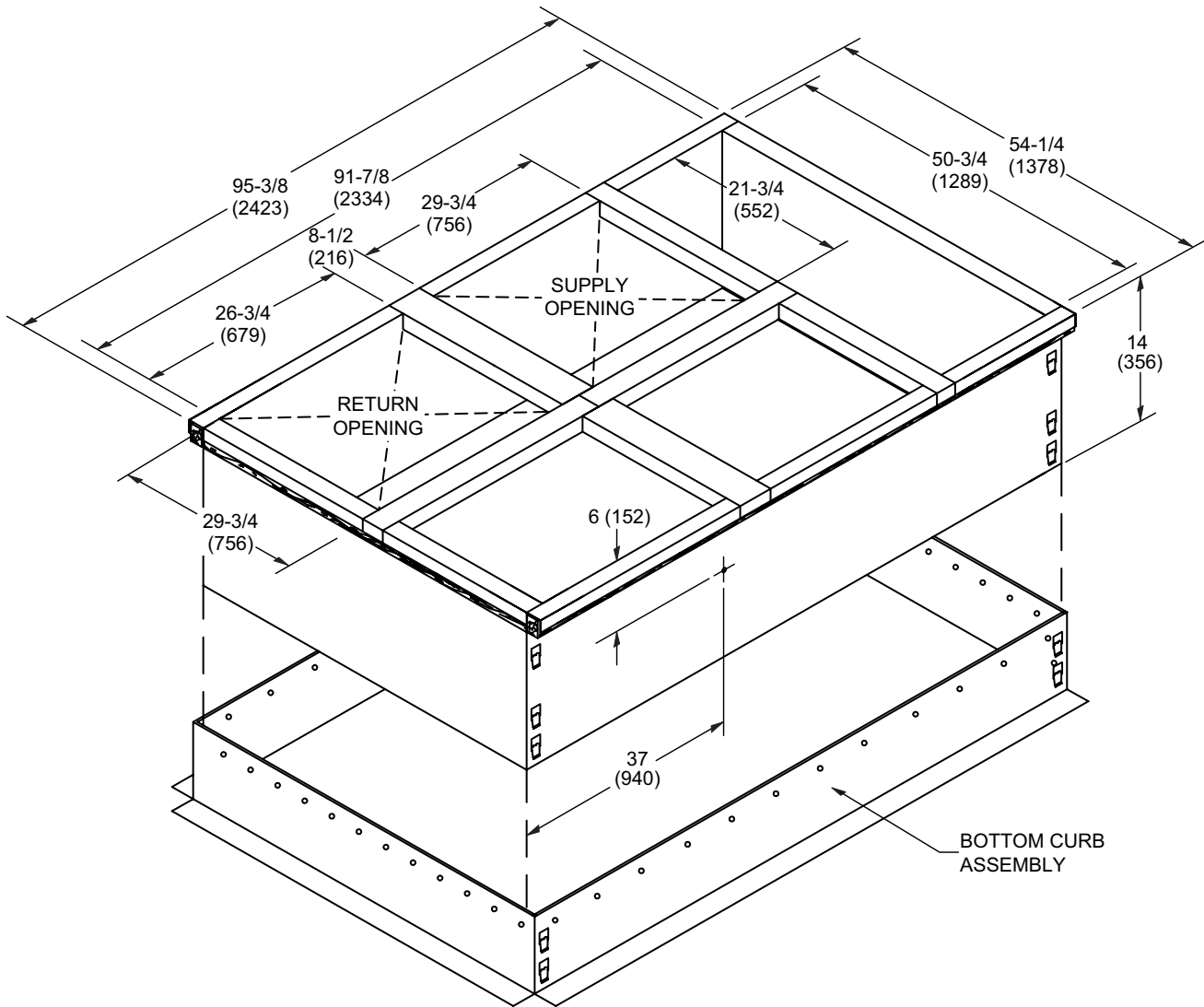

NOTE - Maximum slope pitch is 3/4 in. per 1 foot (19 mm per 305 mm) in any one direction.

TYPICAL FLASHING DETAIL FOR ROOF CURB

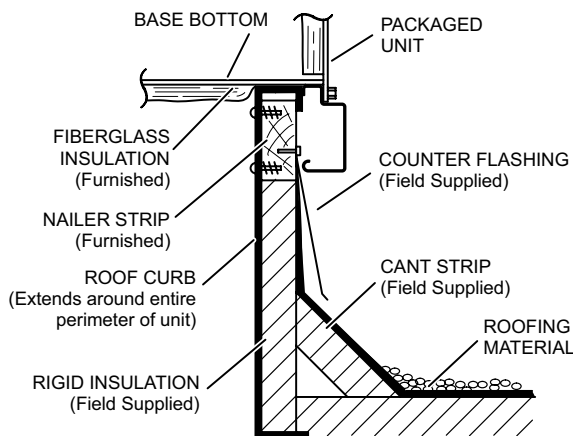

DETAIL ROOF CURB

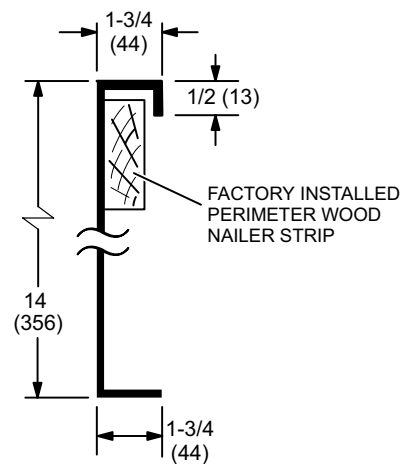

ROOF CURBS WITH SUPPLY & RETURN AIR TRANSITIONS FOR CEILING DIFFUSERS

C1DIFF30B-1 ROUND TRANSITIONS
(for 092 models)

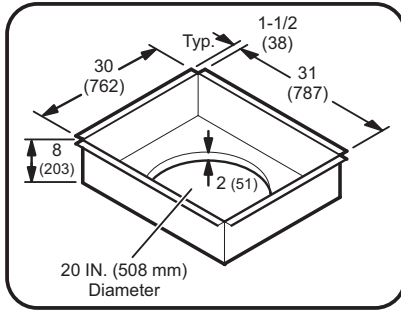

C1DIFF31B-1 & C1DIFF32B-1 RECTANGULAR TRANSITIONS
(for 102 and 120 models)

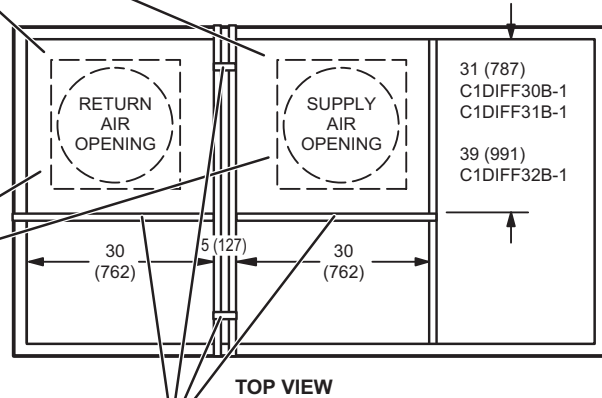
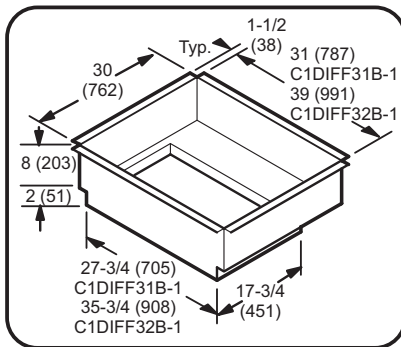

NOTE - These four supports are furnished with the transitions to replace supports furnished with curb for proper transition spacing.

COMBINATION CEILING SUPPLY AND RETURN DIFFUSERS

STEP-DOWN CEILING DIFFUSER

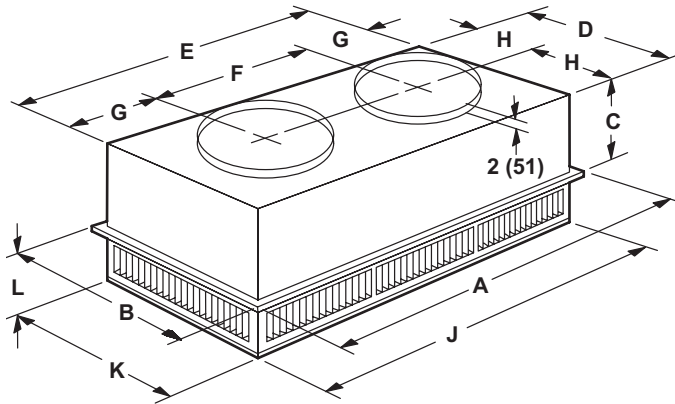

FLUSH CEILING DIFFUSER

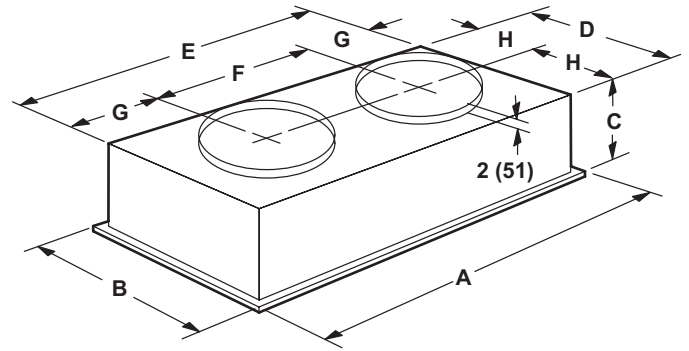

Model		RTD11-95S
A	in.	47-5/8
	mm	1159
B	in.	29-5/8
	mm	752
C	in.	14-3/8
	mm	365
D	in.	27-1/2
	mm	699
E	in.	45-1/2
	mm	1158
F	in.	22-1/2
	mm	572
G	in.	11-1/2
	mm	292
H	in.	13-3/4
	mm	349
J	in.	45-1/2
	mm	1156
K	in.	27-1/2
	mm	699
L	in.	8-1/8
	mm	206
Duct Size	in.	20 round
	mm	508 round

Model		FD11-95S
A	in.	47-5/8
	mm	1159
B	in.	29-5/8
	mm	752
C	in.	16-5/8
	mm	422
D	in.	27
	mm	686
E	in.	45
	mm	1143
F	in.	22-1/2
	mm	572
G	in.	11-1/4
	mm	286
H	in.	13-1/2
	mm	343
Duct Size	in.	20 round
	mm	508 round

COMBINATION CEILING SUPPLY AND RETURN DIFFUSERS

STEP-DOWN CEILING DIFFUSER

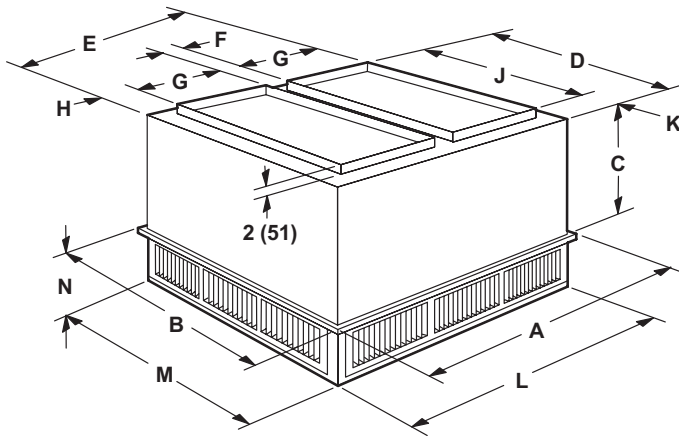

FLUSH CEILING DIFFUSER

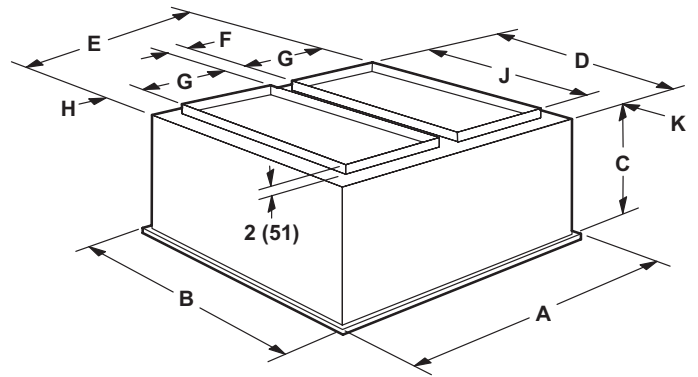

Model		RTD11-135S
A	in.	47-5/8
	mm	1210
B	in.	35-5/8
	mm	905
C	in.	20-5/8
	mm	524
D	in.	33-1/2
	mm	851
E	in.	45-1/2
	mm	1156
F	in.	4-1/2
	mm	114
G	in.	18
	mm	457
H	in.	2-1/2
	mm	64
J	in.	28
	mm	711
K	in.	2-3/4
	mm	70
L	in.	45-1/2
	mm	1156
M	in.	33-1/2
	mm	851
N	in.	9-1/8
	mm	232
Duct Size	in.	18 x 28
	mm	457 x 711

Model		FD11-135S
A	in.	47-5/8
	mm	1210
B	in.	35-5/8
	mm	905
C	in.	23-1/4
	mm	591
D	in.	33
	mm	838
E	in.	45
	mm	1143
F	in.	4-1/2
	mm	114
G	in.	18
	mm	457
H	in.	2-1/4
	mm	57
J	in.	28
	mm	711
K	in.	2-1/2
	mm	64
Duct Size	in.	18 x 28
	mm	457 x 711

REVISIONS

Sections	Description of Change
Optional Conventional Temperature Control Systems	Removed Sysbus System Cable - Product discontinued.



Visit us at www.Lennox.com

For the latest technical information, www.LennoxCommercial.com

Contact us at 1-800-4-LENNOX

NOTE - Due to Lennox' ongoing commitment to quality, Specifications, Ratings and Dimensions subject to change without notice and without incurring liability. Improper installation, adjustment, alteration, service or maintenance can cause property damage or personal injury. Installation and service must be performed by a qualified installer and servicing agency.

©2026 Lennox Industries, Inc.