

# UNIT INFORMATION

# LGT SERIES 7.5 to 12.5 ton

100145

## Service Literature

### LGT092H through 150H with R-454B

The LGT092H-150H units are configured to order units (CTO) with a wide selection of factory-installed options. Units are available in 130,000, 180,000 Btuh or 240,000 Btuh (38.1, 52.7 or 70.3 kW) heating inputs. Gas heat sections are designed with aluminized steel tube heat exchangers with stainless steel as an option.

Cooling capacities range from 7.5 to 12.5 tons. All units are equipped with two compressors.

Units are also designed for R-454B refrigerant. Service equipment must be rated for R-454B.

If the unit must be lifted for service, rig unit by attaching four cables to the holes located in the unit base rail (two holes at each corner). Refer to the installation instructions for the proper rigging technique.

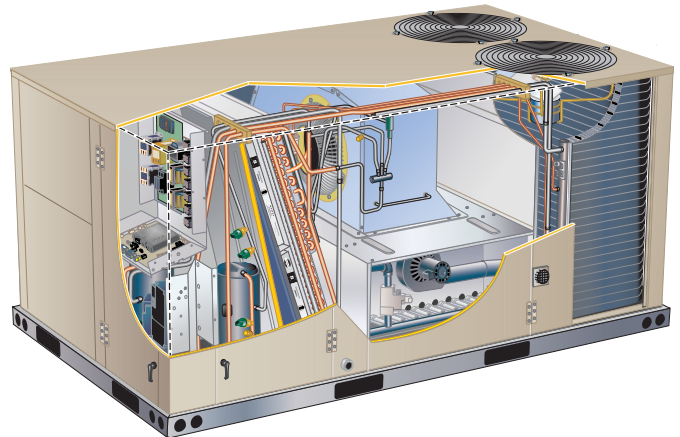

**⚠ WARNING**  
Do not use means to accelerate the defrosting process or to clean, other than those recommended by the manufacturer.  
The appliance shall be stored in a room without continuously operating ignition sources (for example: open flames, an operating gas appliance, or an operating electric heater).  
Do not pierce or burn.  
Be aware that refrigerants may not contain an odor.

**⚠ WARNING**  
If this appliance is conditioning a space with an area smaller than TA min or stored in a space with an area smaller than A min as defined by this instruction, then that space must be without continuously operating open flames (e.g. an operating gas appliance) or other potential ignition sources (e.g. an operating electric heater or similar hot surface). A flame-producing device may be installed in the same space if the device is provided with an effective flame arrest system.

**⚠ WARNING**  
Auxiliary devices which may be potential ignition sources shall not be installed in the duct work. Examples of potential ignition sources are hot surfaces with a temperature exceeding 700°C and electric switching components.

False ceilings or drop ceiling may be used as a return air plenum only if the unit being installed has a Refrigerant Detection System installed.

All maintenance staff and others working in the local area shall be instructed on the nature of work being carried out with work in confined spaces being avoided.

Ensure that the area is in the open or that it is adequately ventilated before breaking into the system or conducting any hot work. A degree of ventilation shall continue during the period that the work is carried out. The ventilation should safely disperse any released refrigerant and preferably expel it externally into the atmosphere.

#### Table of Contents

Options / Accessories . . . . .	Page 3
Specifications . . . . .	Page 6
Blower Tables . . . . .	Page 9
Electrical Data . . . . .	Page 12
Parts Arrangement . . . . .	Page 15
I-Unit Components . . . . .	Page 16
II-Placement and Installation . . . . .	Page 32
III-Charging . . . . .	Page 32
IV-Start Up - Operation . . . . .	Page 42
V-System Service Checks . . . . .	Page 44
VI-Maintenance . . . . .	Page 46
VII-Accessories . . . . .	Page 49
VIII-Direct Drive Supply Air Blower. . . . .	Page 59
IX-Staged Supply Air Operation . . . . .	Page 60
X-Wiring and Operation Sequence. . . . .	Page 61
XI-Decommissioning . . . . .	Page 70

## **⚠ WARNING**

To prevent serious injury or death:

- 1- Lock-out/tag-out before performing maintenance.
- 2- If system power is required (e.g., smoke detector maintenance), disable power to blower, remove fan belt where applicable, and ensure all controllers and thermostats are set to the "OFF" position before performing maintenance.
- 3- Always keep hands, hair, clothing, jewelry, tools, etc., away from moving parts.

## **⚠ WARNING**

Only Manufacturer approved auxiliary devices are permitted to be installed in this unit.

## **⚠ CAUTION**

Any service personnel installing, decommissioning, or performing maintenance on the unit must be properly trained with A2L refrigerants.

## **⚠ WARNING**



Electric shock hazard. Can cause injury or death. Before attempting to perform any service or maintenance, turn the electrical power to unit OFF at disconnect switch(es). Unit may have multiple power supplies.

## **⚠ WARNING**

Improper installation, adjustment, alteration, service or maintenance can cause property damage, personal injury or loss of life. Installation and service must be performed by a licensed professional HVAC installer or equivalent, service agency, or the gas supplier.

## **⚠ CAUTION**

As with any mechanical equipment, contact with sharp sheet metal edges can result in personal injury. Take care while handling this equipment and wear gloves and protective clothing.

## **⚠ WARNING**

- This appliance must be installed in accordance with local and national wiring regulations.
- If the appliance is not fitted with an option for full disconnection from power, a means of disconnection must be incorporated in the fixed wiring in accordance with national and local wiring regulations.

## **⚠ CAUTION**

The appliance is not to be used by persons (including children) with reduced physical, sensory or mental capabilities, or lack of experience and knowledge, unless they have been given supervision or instruction

## **⚠ CAUTION**

Children should be supervised not to play with the appliance.

## **⚠ CAUTION**

Servicing shall be performed only as recommended by the manufacturer.

## **⚠ CAUTION**

Leak Detection System installed. Unit must be powered except for service.

## **⚠ WARNING**

Ducts connected to an appliance shall not contain a potential ignition source.

## **⚠ IMPORTANT**

Pipe work, including piping material, pipe routing, and installation shall include protection from physical damage in operation and service, and be in compliance with national and local codes and standards, such as ASHRAE 15, ASHRAE 15.2, IAPMO Uniform Mechanical Code, ICC International Mechanical Code, or CSA B52. All field joints shall be accessible for inspection prior to being covered or enclosed.

## **⚠ IMPORTANT**

Refrigerant sensors for refrigerant detection systems shall only be replaced with sensors specified by the appliance manufacture.

## **⚠ CAUTION**

This unit is equipped with electrically powered safety measures. To be effective, the unit must be electrically powered at all times after installation, other than when servicing.

## OPTIONS / ACCESSORIES

Item Description	Catalog Number	Unit Model No				
		092	102	120	150	
<b>COOLING SYSTEM</b>						
Condensate Drain Trap	PVC	<b>22H54</b>	OX	OX	OX	OX
	Copper	<b>76W27</b>	X	X	X	X
Drain Pan Overflow Switch		<b>21Z07</b>	OX	OX	OX	OX
<b>HEATING SYSTEM</b>						
Bottom Gas Piping Kit		<b>54W95</b>	X	X	X	X
Combustion Air Intake Extensions		<b>19W51</b>	X	X	X	X
Gas Heat Input	130,000 Btuh	Factory	O	O	O	O
	180,000 Btuh	Factory	O	O	O	O
	240,000 Btuh	Factory	O	O	O	O
Low Temperature Vestibule Heater	208/230V-3ph	<b>22A51</b>	X	X	X	X
	460V	<b>22A55</b>	X	X	X	X
	575V	<b>13X65</b>	X	X	X	X
LPG/Propane Conversion Kits	Standard Heat	<b>14N22</b>	X	X	X	X
	Medium Heat	<b>14N23</b>	X	X	X	X
	High Heat	<b>14N25</b>	X	X	X	X
Stainless Steel Heat Exchanger		Factory	O	O	O	O
Vertical Vent Extension Kit		<b>42W16</b>	X	X	X	X
<b>BLOWER - SUPPLY AIR</b>						
	DirectPlus™ Blower System with MSAV®	Factory	O	O	O	O
	DirectPlus™ Blower System with VAV	Factory	O	O	O	O
<b>CABINET</b>						
Combination Coil/Hail Guards		<b>24C85</b>	OX	OX	OX	OX
Corrosion Protection		Factory	O	O	O	O
Horizontal Discharge Kit		<b>51W25</b>	X	X	X	X
Return Air Adaptor Plate (for LC/LG/LH and TC/TG/TH unit replacement)		<b>54W96</b>	OX	OX	OX	OX
<b>CONTROLS</b>						
Blower Proving Switch		<b>21Z10</b>	OX	OX	OX	OX
Commercial Controls	CPC Einstein Integration	Factory	O	O	O	O
	LonTalk® Module	<b>54W27</b>	OX	OX	OX	OX
	Novar® LSE	Factory	O	O	O	O
Dirty Filter Switch		<b>53W67</b>	OX	OX	OX	OX
Fresh Air Tempering		<b>21Z08</b>	OX	OX	OX	OX
Smoke Detector - Supply or Return (Power board and one sensor)		<b>31A68</b>	OX	OX	OX	OX
Smoke Detector - Supply and Return (Power board and two sensors)		<b>31A69</b>	OX	OX	OX	OX

NOTE - Catalog and model numbers shown are for ordering field installed accessories.

OX - Configure To Order (Factory Installed) or Field Installed

O = Configure To Order (Factory Installed)

X = Field Installed

## OPTIONS / ACCESSORIES

Item Description	Catalog Number	Unit Model No				
		092	102	120	150	
<b>INDOOR AIR QUALITY</b>						
<b>Air Filters</b>						
Healthy Climate® High Efficiency Air Filters 20 x 25 x 2 (Order 4 per unit)	MERV 8	<b>50W61</b>	OX	OX	OX	OX
	MERV 13	<b>52W41</b>	OX	OX	OX	OX
	MERV 16	<b>21U41</b>	X	X	X	X
Replacement Media Filter With Metal Mesh Frame (includes non-pleated filter media)		<b>Y3063</b>	X	X	X	X
<b>Indoor Air Quality (CO<sub>2</sub>) Sensors</b>						
Sensor - Wall-mount, off-white plastic cover with LCD display		<b>77N39</b>	X	X	X	X
Sensor - Wall-mount, off-white plastic cover, no display		<b>23V86</b>	X	X	X	X
Sensor - Black plastic case with LCD display, rated for plenum mounting		<b>87N52</b>	X	X	X	X
Sensor - Wall-mount, black plastic case, no display, rated for plenum mounting		<b>87N54</b>	X	X	X	X
CO <sub>2</sub> Sensor Duct Mounting Kit - for downflow applications		<b>85L43</b>	X	X	X	X
Aspiration Box - for duct mounting non-plenum rated CO <sub>2</sub> sensors ( <b>77N39</b> )		<b>90N43</b>	X	X	X	X
<b>Needlepoint Bipolar Ionization (NPBI)</b>						
Needlepoint Bipolar Ionization (NPBI) Kit		<b>22U15</b>	X	X	X	X
<b>UVC Germicidal Lamps</b>						
<sup>1</sup> Healthy Climate® UVC Light Kit (110/230v-1ph)		<b>21A93</b>	X	X	X	X
Step-Down Transformers	460V primary, 230V secondary	<b>10H20</b>	X	X	X	X
	575V primary, 230V secondary	<b>10H21</b>	X	X	X	X
<b>ELECTRICAL</b>						
Voltage 60 Hz	208/230V - 3 phase	Factory	O	O	O	O
	460V - 3 phase	Factory	O	O	O	O
	575V - 3 phase	Factory	O	O	O	O
HACR Circuit Breakers		Factory	O	O	O	O
<sup>2</sup> Short-Circuit Current Rating (SCCR) of 100kA (includes Phase/Voltage Detection)		Factory	O	O	O	O
Disconnect Switch	80 amp	<b>54W56</b>	OX	OX	OX	OX
GFI Service Outlets	15 amp non-powered, field-wired (208/230V, 460V only)	<b>74M70</b>	OX	OX	OX	OX
	15 amp factory-wired and powered (208/230V, 460V only)	Factory	O	O	O	O
	<sup>3</sup> 20 amp non-powered, field-wired (208/230V, 460V, 575V)	<b>67E01</b>	X	X	X	X
	<sup>3</sup> 20 amp non-powered, field-wired (575V)	Factory	O	O	O	O
Weatherproof Cover for GFI		<b>10C89</b>	X	X	X	X

<sup>1</sup> Lamps operate on 110-230V single-phase power supply. Step-down transformer may be ordered separately for 460V and 575V units. Alternately, 110V power supply may be used to directly power the UVC ballast(s).

<sup>2</sup> Disconnect Switch is furnished and factory installed with High SCCR option.

<sup>3</sup> Canada requires a minimum 20 amp circuit. Select 20 amp, non-powered, field wired GFI.

NOTE - Catalog and model numbers shown are for ordering field installed accessories.

OX - Configure To Order (Factory Installed) or Field Installed

O = Configure To Order (Factory Installed)

X = Field Installed

## OPTIONS / ACCESSORIES

Item Description	Catalog Number	Unit Model No			
		092	102	120	150
<b>ECONOMIZER</b>					
<b>High Performance Economizer (Approved for California Title 24 Building Standards / AMCA Class 1A Certified)</b>					
High Performance Economizer Downflow or Horizontal - Includes Outdoor Air Hood and Downflow Barometric Relief Dampers with Exhaust Hood Order Horizontal Barometric Relief Dampers separately	20U80	OX	OX	OX	OX
<b>Horizontal Barometric Relief Dampers</b>					
Horizontal Low Profile Barometric With Exhaust Hood	53K04	X	X	X	X
<b>Economizer Controls</b>					
Differential Enthalpy (Not for Title 24)	Order 2 21Z09	OX	OX	OX	OX
Sensible Control	Sensor is Furnished Factory	O	O	O	O
Single Enthalpy	21Z09	OX	OX	OX	OX
Building Pressure Control	13J77	X	X	X	X
Outdoor Air CFM Control	13J76	X	X	X	X
Global Control	Sensor Field Provided Factory	O	O	O	O
<b>OUTDOOR AIR</b>					
<b>Outdoor Air Dampers With Outdoor Air Hood</b>					
Motorized	14G28	OX	OX	OX	OX
Manual	14G29	X	X	X	X
<b>POWER EXHAUST</b>					
Standard Static	208/230V-3ph 53W44	OX	OX	OX	OX
	460V-3ph 53W45	OX	OX	OX	OX
	575V-3ph 53W46	OX	OX	OX	OX
<b>HUMIDITROL® CONDENSER REHEAT OPTION</b>					
Humiditrol Dehumidification Option	Factory	O	O	O	O
<b>ROOF CURBS</b>					
<b>Hybrid Roof Curbs, Downflow</b>					
8 in. height	11F54	X	X	X	X
14 in. height	11F55	X	X	X	X
18 in. height	11F56	X	X	X	X
24 in. height	11F57	X	X	X	X
<b>Adjustable Pitch Curb, Downflow</b>					
14 in. height	54W50	X	X	X	X
<b>CEILING DIFFUSERS</b>					
Step-Down - Order one	RTD11-95S 13K61	X			
	RTD11-135S 13K62		X	X	
	RTD11-185S 13K63				X
Flush - Order one	FD11-95S 13K56	X			
	FD11-135S 13K57		X	X	
	FD11-185S 13K58				X
Transitions (Supply and Return) - Order one	C1DIFF30B-1 12X65	X			
	C1DIFF31B-1 12X66		X	X	
	C1DIFF32B-1 12X67				X

NOTE - Catalog and model numbers shown are for ordering field installed accessories.

OX - Configure To Order (Factory Installed) or Field Installed

O = Configure To Order (Factory Installed)

X = Field Installed

SPECIFICATIONS		MSAV MODELS				
Model		LGT092H5E	LGT102H5E	LGT120H5E	LGT150H5E	
<b>Nominal Tonnage</b>		7.5 Ton	8.5 Ton	10 Ton	12.5 Ton	
<b>Efficiency Type</b>		High	High	High	High	
<b>Blower Type</b>		DirectPlus™ ECM Direct Drive with MSAV®	DirectPlus™ ECM Direct Drive with MSAV®	DirectPlus™ ECM Direct Drive with MSAV®	DirectPlus™ ECM Direct Drive with MSAV®	
<b>Cooling Performance</b>	Gross Cooling Capacity - Btuh	94,000	103,000	121,000	142,000	
	<sup>1</sup> Net Cooling Capacity - Btuh	92,000	100,000	118,000	138,000	
	<sup>1</sup> AHRI Rated Air Flow - cfm	3000	3400	3400	4100	
	<sup>1</sup> IEER (Btuh/Watt)	16.1	16.1	16.1	15.4	
	<sup>1</sup> EER (Btuh/Watt)	12.3	12.1	12.1	10.8	
Total Unit Power (kW)		7.6	8.0	9.9	12.8	
<b>Sound Rating Number</b>	dBA	88	88	89	89	
<b>Refrigerant Charge</b>	Refrigerant Type	R-454B	R-454B	R-454B	R-454B	
	Without Reheat Option	Circuit 1	6 lbs. 4 oz.	6 lbs. 4 oz.	5 lbs. 14 oz.	5 lbs. 12 oz.
		Circuit 2	5 lbs. 14 oz.	5 lbs. 14 oz.	5 lbs. 14 oz.	6 lbs. 4 oz.
	With Reheat Option	Circuit 1	6 lbs. 8 oz.	6 lbs. 8 oz.	6 lbs. 4 oz.	6 lbs. 2 oz.
		Circuit 2	5 lbs. 14 oz.	5 lbs. 14 oz.	5 lbs. 14 oz.	6 lbs. 4 oz.
<b>Gas Heating Options Available</b>		See page 8				
<b>Compressor Type (number)</b>		Two-Stage Scroll (1) Single-Stage Scroll (1)				
<b>Outdoor Coils</b>	Net face area - ft. <sup>2</sup> (total)	27.5	27.5	27.5	27.5	
	Rows	1	1	1	1	
	Fins - in.	20	20	20	20	
<b>Outdoor Coil Fans</b>	Motor HP (number and type)	1/3 (2 PSC)	1/3 (2 PSC)	1/2 (2 PSC)	1/2 (2 PSC)	
	Rpm	1075	1075	1075	1075	
	Watts (total)	860	860	1000	1000	
	Diameter (Number) - in.	(2) 24	(2) 24	(2) 24	(2) 24	
	Blades	3	3	3	3	
	Total Air volume - cfm	9000	9000	9700	9700	
<b>Indoor Coil</b>	Net face area - ft. <sup>2</sup> (total)	13.54	13.54	13.54	13.54	
	Tube diameter - in.	3/8	3/8	3/8	3/8	
	Rows	4	4	4	4	
	Fins - in.	14	14	14	14	
	Condensate drain size (NPT) - in.	(1) 1				
Expansion device type		Balanced Port Thermostatic Expansion Valve,removable power element				
<b>Indoor Blower</b>	Motor HP (number and type)	3.75 (1 ECM)	3.75 (1 ECM)	3.75 (1 ECM)	3.75 (1 ECM)	
	Wheel (Number) diameter x width - in.	(1) 22 x 9	(1) 22 x 9	(1) 22 x 9	(1) 22 x 9	
<b>Filters</b>	Type of filter	MERV 4, Disposable				
	Number and size - in.	(4) 20 x 25 x 2				
<b>Line voltage data (Volts-Phase-Hz)</b>		208/230-3-60, 460-3-60, 575-3-60				

NOTE - Net capacity includes evaporator blower motor heat deduction. Gross capacity does not include evaporator blower motor heat deduction.

<sup>1</sup> AHRI Certified to AHRI Standard 340/360; 95°F outdoor air temperature and 80°F db/67°F wb entering evaporator air; minimum external duct static pressure.

SPECIFICATIONS			VAV MODELS			
Model			LGT092H5P	LGT102H5P	LGT120H5P	LGT150H5P
<b>Nominal Tonnage</b>			7.5 Ton	8.5 Ton	10 Ton	12.5 Ton
<b>Efficiency Type</b>			High	High	High	High
<b>Blower Type</b>			DirectPlus™ ECM Direct Drive with VAV	DirectPlus™ ECM Direct Drive with VAV	DirectPlus™ ECM Direct Drive with VAV	DirectPlus™ ECM Direct Drive with VAV
<b>Cooling Performance</b>	Gross Cooling Capacity - Btuh		94,000	103,000	121,000	142,000
	<sup>1</sup> Net Cooling Capacity - Btuh		92,000	100,000	118,000	138,000
	<sup>1</sup> AHRI Rated Air Flow - cfm		3000	3400	3400	4100
	<sup>1</sup> IEER (Btuh/Watt)		15.5	15.5	15.5	14.6
	<sup>1</sup> EER (Btuh/Watt)		12.3	12.1	12.1	10.8
	Total Unit Power (kW)		7.6	8.0	9.9	12.8
<b>Sound Rating Number</b>	dBA		88	88	89	89
<b>Refrigerant Charge</b>	Refrigerant Type		R-454B	R-454B	R-454B	R-454B
	Without Reheat Option	Circuit 1	6 lbs. 4 oz.	6 lbs. 4 oz.	5 lbs. 14 oz.	5 lbs. 12 oz.
		Circuit 2	5 lbs. 14 oz.	5 lbs. 14 oz.	5 lbs. 14 oz.	6 lbs. 4 oz.
<b>Gas Heating Options Available</b>			See page 8			
<b>Compressor Type (number)</b>			Two-Stage Scroll (1) Single-Stage Scroll (1)			
<b>Outdoor Coils</b>	Net face area - ft. <sup>2</sup> (total)		27.5	27.5	27.5	27.5
	Rows		1	1	1	1
	Fins - in.		20	20	20	20
<b>Outdoor Coil Fans</b>	Motor (number) HP (type)		(2) 1/3 (PSC)	(2) 1/3 (PSC)	(2) 1/2 (PSC)	(2) 1/2 (PSC)
	Rpm		1075	1075	1075	1075
	Watts (total)		860	860	1000	1000
	Diameter (Number) - in.		(2) 24	(2) 24	(2) 24	(2) 24
	Blades		3	3	3	3
	Total Air volume - cfm		9000	9000	9700	9700
<b>Indoor Coil</b>	Net face area - ft. <sup>2</sup> (total)		13.54	13.54	13.54	13.54
	Tube diameter - in.		3/8	3/8	3/8	3/8
	Rows		4	4	4	4
	Fins - in.		14	14	14	14
	Condensate drain size (NPT) - in.		(1) 1			
	Expansion device type		Balanced Port Thermostatic Expansion Valve,removable power element			
<b>Indoor Blower</b>	Motor HP (number and type)		3.75 (1 ECM)	3.75 (1 ECM)	3.75 (1 ECM)	3.75 (1 ECM)
	Wheel (Number) diameter x width - in.		(1) 22 x 9	(1) 22 x 9	(1) 22 x 9	(1) 22 x 9
<b>Filters</b>	Type of filter		MERV 4, Disposable			
	Number and size - in.		(4) 20 x 25 x 2			
<b>Line voltage data (Volts-Phase-Hz)</b>			208/230-3-60, 460-3-60, 575-3-60			

NOTE - Net capacity includes evaporator blower motor heat deduction. Gross capacity does not include evaporator blower motor heat deduction.

<sup>1</sup> AHRI Certified to AHRI Standard 340/360; 95°F outdoor air temperature and 80°F db/67°F wb entering evaporator air; minimum external duct static pressure.

SPECIFICATIONS			GAS HEAT		
Heat Input Type			Standard	Medium	High
Number of Gas Heat Stages			2	2	2
Gas Heating Performance	Input - Btuh	First Stage	85,000	117,000	156,000
		Second Stage	130,000	180,000	240,000
	Output - Btuh	Second Stage	105,000	146,000	194,000
	Temperature Rise Range - °F		15 - 45	30 - 60	40 - 70
	Minimum Air Volume - cfm		2150	2250	2600
	Thermal Efficiency		81%	81%	81%
	Gas Supply Connections		3/4 in. NPT	3/4 in. NPT	3/4 in. NPT.
Recommended Gas Supply Pressure - Nat. / LPG			7 in. w.g. / 11 in. w.g.		
Gas Supply Pressure Range	Min./Max. (Natural)		4.7 - 10.5 in. w.g.		
	Min./Max. (LPG)		10.8 - 13.5 in. w.g.		

### HIGH ALTITUDE DERATE

**NOTE** - Units may be installed at altitudes up to 2000 feet above sea level without any modifications.

At altitudes above 2000 feet units must be derated to match gas manifold pressures shown in table below.

At altitudes above 4500 feet unit must be derated 4% for each 1000 feet above sea level.

**NOTE** - This is the only permissible derate for these units.

Refer to the Installation Instructions for more detailed information.

Heat Input Type	Altitude Feet	Gas Manifold Pressure in. w.g.		Input Rate (Btuh)
		Natural Gas	LPG/ Propane	
Standard (2 stage)	2001 - 4500	1.6 / 3.1	4.4 / 8.9	84,500 / 120,000
Medium (2 stage)	2001 - 4500	1.6 / 3.1	4.4 / 8.9	117,000 / 166,000
High (2 stage)	2001 - 4500	1.6 / 3.1	4.4 / 8.9	156,000 / 221,000

## BLOWER DATA

**BLOWER TABLE INCLUDES RESISTANCE FOR BASE UNIT ONLY (NO HEAT SECTION) WITH DRY INDOOR COIL AND AIR FILTERS IN PLACE.**

FOR ALL UNITS ADD:

- 1 – Wet indoor coil air resistance of selected unit.
- 2 – Any factory installed options air resistance (heat section, Economizer, etc.)
- 3 – Any field installed accessories air resistance (duct resistance, diffuser, etc.)

See page 10 for wet coil and option/accessory air resistance data.

**Maximum Static Pressure With Gas Heat - 2.0 in. w.g.**

**Minimum Air Volume Required For Different Gas Heat Sizes:**

Standard - 2150 cfm; Medium - 2250 cfm; High - 2600 cfm

Total Air Volume cfm	Total Static Pressure - in. w.g.													
	0.2		0.4		0.6		0.8		1.0		1.2		1.4	
	RPM	Watts	RPM	Watts	RPM	Watts	RPM	Watts	RPM	Watts	RPM	Watts	RPM	Watts
1750	644	137	740	235	796	302	833	343	873	373	996	558	1065	664
2000	675	165	768	260	821	330	861	386	960	507	1026	629	1094	753
2250	711	195	803	290	856	375	901	497	991	564	1058	703	1128	840
2500	764	241	852	335	904	439	951	568	1025	641	1097	789	1170	934
2750	847	316	901	399	946	543	1004	674	1074	746	1146	895	1220	1041
3000	944	426	980	511	1021	671	1074	803	1136	874	1205	1021	1276	1167
3250	1022	544	1057	640	1099	810	1149	942	1207	1012	1272	1156	1338	1304
3500	1092	666	1131	770	1174	948	1225	1081	1281	1151	1342	1297	1402	1451
3750	1161	780	1202	892	1248	1079	1298	1217	1353	1291	1409	1445	1463	1609
4000	1230	888	1273	1010	1319	1212	1369	1362	1421	1441	1471	1608	1518	1784
4250	1299	1006	1342	1140	1388	1362	1436	1526	1483	1612	1528	1790	1571	1975
4500	1366	1142	1409	1289	1454	1532	1498	1708	1542	1798	1583	1984	1623	2172
4750	1432	1295	1474	1457	1516	1719	1558	1903	1598	1997	1637	2187	1674	2377
5000	1496	1471	1537	1645	1577	1921	1616	2110	1654	2205	1690	2396	1726	2586
5250	1560	1667	1598	1849	1636	2132	1673	2324	1709	2419	1744	2609	1779	2796
5500	1623	1878	1659	2064	1695	2349	1731	2539	1765	2634	---	---	---	---
5750	1686	2097	1720	2284	1755	2567	---	---	---	---	---	---	---	---
6000	1748	2316	1781	2502	---	---	---	---	---	---	---	---	---	---

Total Air Volume cfm	Total Static Pressure - in. w.g.											
	1.6		1.8		2.0		2.2		2.4		2.6	
	RPM	Watts	RPM	Watts	RPM	Watts	RPM	Watts	RPM	Watts	RPM	Watts
1750	1134	775	1203	896	1275	1025	1356	1149	1422	1287	1470	1439
2000	1162	878	1231	1007	1302	1139	1379	1268	1440	1411	1486	1570
2250	1198	975	1268	1111	1338	1250	1409	1388	1464	1542	1507	1711
2500	1243	1075	1313	1217	1380	1365	1442	1517	1491	1685	1533	1860
2750	1293	1186	1361	1336	1423	1494	1477	1661	1520	1839	1561	2016
3000	1346	1317	1410	1474	1466	1642	1514	1818	1554	2000	1594	2180
3250	1402	1460	1460	1627	1511	1803	1553	1986	1591	2172	1631	2352
3500	1459	1616	1509	1793	1555	1976	1594	2165	1631	2352	1671	2531
3750	1512	1785	1557	1970	1599	2159	1636	2350	1673	2536	1713	2714
4000	1562	1969	1604	2157	1643	2347	1680	2538	1717	2722	1756	2896
4250	1611	2163	1650	2352	1688	2541	1724	2729	1762	2908	---	---
4500	1661	2362	1698	2552	1734	2739	1770	2922	---	---	---	---
4750	1710	2567	1746	2754	---	---	---	---	---	---	---	---
5000	1761	2774	---	---	---	---	---	---	---	---	---	---

## BLOWER DATA

### FACTORY INSTALLED OPTIONS/FIELD INSTALLED ACCESSORY AIR RESISTANCE - in. w.g.

Air Volume cfm	Wet Indoor Coil		Gas Heat Exchanger			Economizer	Humiditrol® Reheat Coil	Filters			Return Air Adaptor Plate
			Standard Heat	Medium Heat	High Heat			MERV 8	MERV 13	MERV 16	
	092, 102	120, 150									
1750	0.04	0.04	0.06	0.02	0.02	0.05	0.02	0.01	0.03	0.06	0.00
2000	0.05	0.05	0.07	0.05	0.06	0.06	0.02	0.01	0.03	0.08	0.00
2250	0.06	0.06	0.07	0.07	0.08	0.08	0.02	0.01	0.04	0.09	0.00
2500	0.07	0.07	0.09	0.10	0.11	0.11	0.03	0.01	0.05	0.10	0.00
2750	0.08	0.08	0.09	0.11	0.12	0.12	0.03	0.02	0.05	0.11	0.00
3000	0.10	0.09	0.11	0.12	0.13	0.13	0.03	0.02	0.06	0.12	0.02
3250	0.11	0.10	0.12	0.15	0.16	0.15	0.04	0.02	0.06	0.13	0.02
3500	0.12	0.11	0.12	0.16	0.17	0.15	0.04	0.03	0.07	0.15	0.04
3750	0.14	0.13	0.14	0.19	0.20	0.15	0.05	0.03	0.08	0.16	0.07
4000	0.15	0.14	0.14	0.21	0.22	0.19	0.05	0.04	0.08	0.17	0.09
4250	0.17	0.15	0.14	0.24	0.28	0.19	0.06	0.04	0.09	0.19	0.11
4500	0.19	0.17	0.15	0.26	0.32	0.22	0.07	0.04	0.09	0.20	0.12
4750	0.20	0.18	0.16	0.29	0.37	0.25	0.07	0.05	0.10	0.21	0.16
5000	0.22	0.20	0.16	0.34	0.43	0.29	0.08	0.06	0.10	0.23	0.18
5250	0.24	0.22	0.16	0.37	0.47	0.32	0.08	0.06	0.11	0.24	0.19
5500	0.25	0.23	0.18	0.44	0.54	0.34	0.09	0.07	0.12	0.25	0.22
5750	0.27	0.25	0.19	0.49	0.59	0.45	0.10	0.07	0.12	0.27	0.25
6000	0.29	0.27	0.20	0.54	0.64	0.52	0.10	0.08	0.13	0.28	0.27

### POWER EXHAUST FAN PERFORMANCE

Return Air System Static Pressure	Air Volume Exhausted
in. w.g.	cfm
0	3175
0.05	2955
0.10	2685
0.15	2410
0.20	2165
0.25	1920
0.30	1420
0.35	1200

## BLOWER DATA

### CEILING DIFFUSERS AIR RESISTANCE - in. w.g.

Unit Size	RTD11 Step-Down Diffuser			FD11 Flush Diffuser	
	Air Volume cfm	2 Ends Open	1 Side, 2 Ends Open		All Ends & Sides Open
092 Models	2400	0.21	0.18	0.15	0.14
	2600	0.24	0.21	0.18	0.17
	2800	0.27	0.24	0.21	0.20
	3000	0.32	0.29	0.25	0.25
	3200	0.41	0.37	0.32	0.31
	3400	0.50	0.45	0.39	0.37
	3600	0.61	0.54	0.48	0.44
	3800	0.73	0.63	0.57	0.51
102 & 120 Models	3600	0.36	0.28	0.23	0.15
	3800	0.40	0.32	0.26	0.18
	4000	0.44	0.36	0.29	0.21
	4200	0.49	0.40	0.33	0.24
	4400	0.54	0.44	0.37	0.27
	4600	0.60	0.49	0.42	0.31
	4800	0.65	0.53	0.46	0.35
	5000	0.69	0.58	0.50	0.39
150 Models	5200	0.75	0.62	0.54	0.43
	4200	0.22	0.19	0.16	0.10
	4400	0.28	0.24	0.20	0.12
	4600	0.34	0.29	0.24	0.15
	4800	0.40	0.34	0.29	0.19
	5000	0.46	0.39	0.34	0.23
	5200	0.52	0.44	0.39	0.27
	5400	0.58	0.49	0.43	0.31
5600	0.64	0.54	0.47	0.35	
5800	0.70	0.59	0.51	0.39	

### CEILING DIFFUSER AIR THROW DATA

Model No.	Air Volume cfm	<sup>1</sup> Effective Throw Range	
		RTD11 Step-Down	FD11 Flush
		ft.	ft.
092 Models	2600	24 - 29	19 - 24
	2800	25 - 30	20 - 28
	3000	27 - 33	21 - 29
	3200	28 - 35	22 - 29
	3400	30 - 37	22 - 30
102, 120 Models	3600	25 - 33	22 - 29
	3800	27 - 35	22 - 30
	4000	29 - 37	24 - 33
	4200	32 - 40	26 - 35
	4400	34 - 42	28 - 37
150 Models	5600	39 - 49	28 - 37
	5800	42 - 51	29 - 38
	6000	44 - 54	40 - 50
	6200	45 - 55	42 - 51
	6400	46 - 55	43 - 52
6600	47 - 56	45 - 56	

<sup>1</sup> Throw is the horizontal or vertical distance an air stream travels on leaving the outlet or diffuser before the maximum velocity is reduced to 50 ft. per minute. Four sides open.

**ELECTRICAL DATA****7.5 TON**

Model No.		LGT092H5E / LGT092H5P		
<sup>1</sup> Voltage - 60Hz		208/230V-3ph	460V-3ph	575V-3ph
Compressor 1 (Non-Inverter)	Rated Load Amps	11.9	6.8	4.8
	Locked Rotor Amps	112	61.8	39
Compressor 2 (Non-Inverter)	Rated Load Amps	12.2	6.4	5.1
	Locked Rotor Amps	120.4	50	41
Outdoor Fan Motors (2)	Full Load Amps (2 Non-ECM)	2.4	1.3	1
	Total	4.8	2.6	2
Power Exhaust (1) 0.33 HP	Full Load Amps	2.4	1.3	1
Service Outlet 115V GFI (amps)		15	15	20
Indoor Blower Motor	HP	3.75	3.75	3.75
	Full Load Amps	8	4.2	3.6
<sup>2</sup> Maximum Overcurrent Protection (MOCP)	Unit Only	50	25	20
	With (1) 0.33 HP Power Exhaust	50	25	20
<sup>3</sup> Minimum Circuit Ampacity (MCA)	Unit Only	40	22	17
	With (1) 0.33 HP Power Exhaust	43	24	18

NOTE - All units have a minimum Short Circuit Current Rating (SCCR) of 5000 amps.

<sup>1</sup> Extremes of operating range are plus and minus 10% of line voltage.<sup>2</sup> HACR type breaker or fuse.<sup>3</sup> Refer to National or Canadian Electrical Code manual to determine wire, fuse and disconnect size requirements.**ELECTRICAL DATA****8.5 TON**

Model No.		LGT102H5E / LGT102H5P		
<sup>1</sup> Voltage - 60Hz		208/230V-3ph	460V-3ph	575V-3ph
Compressor 1 (Non-Inverter)	Rated Load Amps	11.9	6.8	4.8
	Locked Rotor Amps	112	61.8	39
Compressor 2 (Non-Inverter)	Rated Load Amps	12.8	6	5.8
	Locked Rotor Amps	120.4	49.4	41
Outdoor Fan Motors (2)	Full Load Amps (2 Non-ECM)	2.4	1.3	1
	Total	4.8	2.6	2
Power Exhaust (1) 0.33 HP	Full Load Amps	2.4	1.3	1
Service Outlet 115V GFI (amps)		15	15	20
Indoor Blower Motor	HP	3.75	3.75	3.75
	Full Load Amps	8	4.2	3.6
<sup>2</sup> Maximum Overcurrent Protection (MOCP)	Unit Only	50	25	20
	With (1) 0.33 HP Power Exhaust	50	25	20
<sup>3</sup> Minimum Circuit Ampacity (MCA)	Unit Only	41	22	18
	With (1) 0.33 HP Power Exhaust	44	23	19

NOTE - All units have a minimum Short Circuit Current Rating (SCCR) of 5000 amps.

<sup>1</sup> Extremes of operating range are plus and minus 10% of line voltage.<sup>2</sup> HACR type breaker or fuse.<sup>3</sup> Refer to National or Canadian Electrical Code manual to determine wire, fuse and disconnect size requirements.

**ELECTRICAL DATA****10 TON**

Model No.		LGT120H5E / LGT120H5P		
<sup>1</sup> Voltage - 60Hz		208/230V-3ph	460V-3ph	575V-3ph
Compressor 1 (Non-Inverter)	Rated Load Amps	13.8	6.9	5.8
	Locked Rotor Amps	150	58	47.8
Compressor 2 (Non-Inverter)	Rated Load Amps	16	7.1	6.4
	Locked Rotor Amps	156.4	69	47.8
Outdoor Fan Motors (2)	Full Load Amps (2 Non-ECM)	3	1.5	1.2
	Total	6	3	2.4
Power Exhaust (1) 0.33 HP	Full Load Amps	2.4	1.3	1
Service Outlet 115V GFI (amps)		15	15	20
Indoor Blower Motor	HP	3.75	3.75	3.75
	Full Load Amps	8	4.2	3.6
<sup>2</sup> Maximum Overcurrent Protection (MOCP)	Unit Only	60	30	25
	With (1) 0.33 HP Power Exhaust	60	30	25
<sup>3</sup> Minimum Circuit Ampacity (MCA)	Unit Only	48	23	20
	With (1) 0.33 HP Power Exhaust	51	25	21

NOTE - All units have a minimum Short Circuit Current Rating (SCCR) of 5000 amps.

<sup>1</sup> Extremes of operating range are plus and minus 10% of line voltage.<sup>2</sup> HACR type breaker or fuse.<sup>3</sup> Refer to National or Canadian Electrical Code manual to determine wire, fuse and disconnect size requirements.**ELECTRICAL DATA****12.5 TON**

Model No.		LGT150H5E/ LGT150H5P		
<sup>1</sup> Voltage - 60Hz		208/230V-3ph	460V-3ph	575V-3ph
Compressor 1 (Non-Inverter)	Rated Load Amps	19.2	9.1	6.2
	Locked Rotor Amps	162.3	70.8	58.2
Compressor 2 (Non-Inverter)	Rated Load Amps	22.4	9.1	7.2
	Locked Rotor Amps	166.2	74.6	54
Outdoor Fan Motors (2)	Full Load Amps (2 Non-ECM)	3	1.5	1.2
	Total	6	3	2.4
Power Exhaust (1) 0.33 HP	Full Load Amps	2.4	1.3	1
Service Outlet 115V GFI (amps)		15	15	20
Indoor Blower Motor	HP	3.75	3.75	3.75
	Full Load Amps	8	4.2	3.6
<sup>2</sup> Maximum Overcurrent Protection (MOCP)	Unit Only	80	35	25
	With (1) 0.33 HP Power Exhaust	80	35	25
<sup>3</sup> Minimum Circuit Ampacity (MCA)	Unit Only	62	28	22
	With (1) 0.33 HP Power Exhaust	64	29	23

NOTE - All units have a minimum Short Circuit Current Rating (SCCR) of 5000 amps.

<sup>1</sup> Extremes of operating range are plus and minus 10% of line voltage.<sup>2</sup> HACR type breaker or fuse.<sup>3</sup> Refer to National or Canadian Electrical Code manual to determine wire, fuse and disconnect size requirements.

## Minimum R454B Space and CFM Requirements

Minimum Airflow <sup>1</sup>		
Unit	Q <sub>min</sub> (CFM)	Q <sub>min</sub> (m <sup>3</sup> /h)
LCT/LGT092	165	281
LCT/LGT102	165	281
LCT/LGT120	155	264
LCT/LGT150	165	281
LCT/LGT092 W/ Humidrol	172	292
LCT/LGT102 W/ Humidrol	172	292
LCT/LGT120 W/ Humidrol	165	281
LCT/LGT150 W/ Humidrol	165	281

<sup>1</sup> **NOTE** - The minimum airflow is the lowest CFM allowed during venting operation (leak mitigation).

Minimum Room Area of Conditioned Space <sup>2</sup>		
Unit	TA <sub>min</sub> (ft <sup>2</sup> )	TA <sub>min</sub> (m <sup>2</sup> )
LCT/LGT092	92	8.5
LCT/LGT102	92	8.5
LCT/LGT120	87	8.0
LCT/LGT150	92	8.5
LCT/LGT092 W/ Humidrol	96	8.8
LCT/LGT102 W/ Humidrol	96	8.8
LCT/LGT120 W/ Humidrol	92	8.5
LCT/LGT150 W/ Humidrol	92	8.5

<sup>2</sup> **NOTE** - The minimum room area of conditioned space is the smallest area the unit can service.

Refrigerant Charge R-454B		
Unit	M <sub>c</sub> (lbs)	M <sub>c</sub> (kg)
LCT/LGT092 STG 1	6.25	2.83
LCT/LGT092 STG 2	5.88	2.67
LCT/LGT102 STG 1	6.25	2.83
LCT/LGT102 STG 2	5.88	2.67
LCT/LGT120 STG 1	5.88	2.67
LCT/LGT120 STG 2	5.88	2.67
LCT/LGT150 STG 1	5.75	2.61
LCT/LGT150 STG 2	6.25	2.83
LCT/LGT092 W/ Humidrol STG 1	6.5	2.95
LCT/LGT092 W/ Humidrol STG 2	5.88	2.67
LCT/LGT102 W/ Humidrol STG 1	6.5	2.95
LCT/LGT102 W/ Humidrol STG 2	5.88	2.67
LCT/LGT120 W/ Humidrol STG 1	6.25	2.83
LCT/LGT120 W/ Humidrol STG 2	5.88	2.67
LCT/LGT150 W/ Humidrol STG 1	6.13	2.78
LCT/LGT150 W/ Humidrol STG 2	6.25	2.83

Altitude Adjustment Factor <sup>3</sup>									
Halt	0	200	400	600	800	1000	1200	1400	1600
AF	1	1	1	1	1.02	1.05	1.04	1.1	1.12
Halt	1600	1800	2000	2200	2400	2600	2800	3000	3200
AF	1.12	1.15	1.18	1.21	1.25	1.28	1.32	1.36	1.4

<sup>3</sup> **NOTE** - Use the Altitude Adjustment Factor to adjust the values in the tables above to different altitudes. Find the relevant altitude above sea level in the two "Halt" rows and then multiply the value needed from the tables above by the altitude factor number. Example: For the minimum airflow in CFM for an LCT/LGT092 at 1000 ft. above sea level, multiply 165 by 1.05 to get 173.25 CFM as the new Q<sub>min</sub>.

# Parts Arrangement

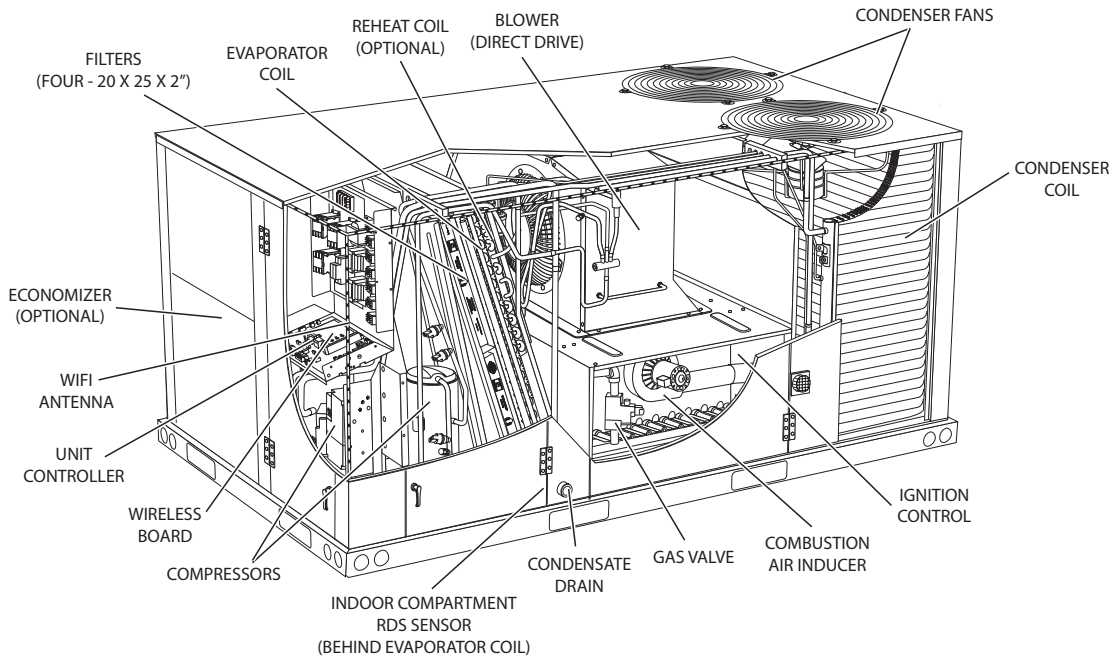

FIGURE 1

# CONTROL BOX PARTS ARRANGEMENT

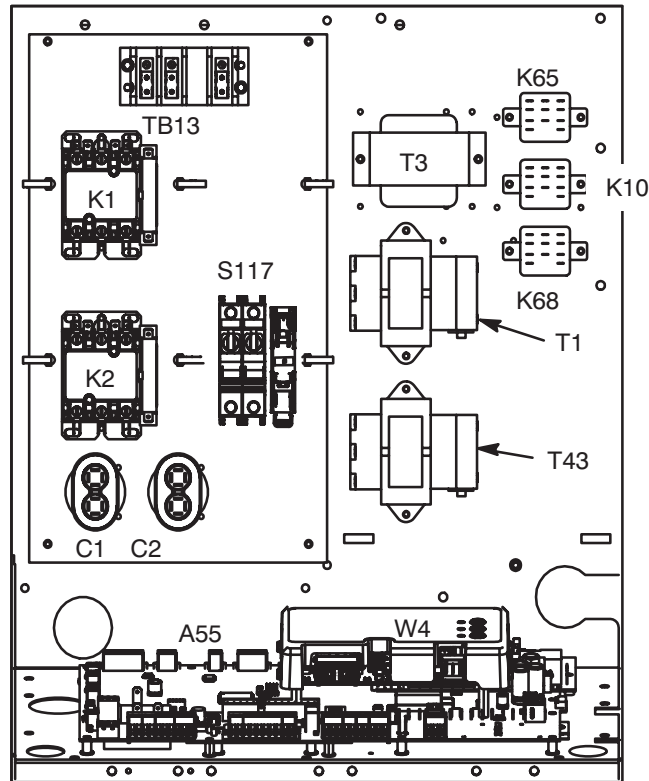



FIGURE 2

## I-UNIT COMPONENTS

<b>⚠ WARNING</b>	
	<b>Electric shock hazard. Can cause injury or death. Before attempting to perform any service or maintenance, turn the electrical power to unit OFF at disconnect switch(es). Unit may have multiple power supplies.</b>

<b>ELECTROSTATIC DISCHARGE (ESD) Precautions and Procedures</b>	
<b>⚠ CAUTION</b>	
	<b>Electrostatic discharge can affect electronic components. Take precautions to neutralize electrostatic charge by touching your hand and tools to metal prior to handling the control.</b>

All 7.5 through 12.5 ton (38.1 through 70.3 kW) units are configured to order units (CTO). The LGT unit components are shown in figure 1. All units come standard with hinged unit panels. All L1, L2 and L3 wiring is color coded; L1 is red, L2 is yellow and L3 is blue.

### A-Control Box Components

LGT control box components are shown in FIGURE 2. The control box is located in the upper portion of the compressor compartment.

#### 1-Disconnect Switch S48 (Optional)

All units may be equipped with an optional disconnect switch S48. Other factory or field installed optional circuit breakers may be used, such as CB10. S48 and CB10 are toggle switches, which can be used by the service technician to disconnect power to the unit.

#### 2-Control Transformer T43 (Re-Heat Units)

T43 is a single line voltage to 24VAC and ties into T1. See unit diagram. T43 is mounted in the control box. The transformer supplies power to control circuits (through T1). The transformer is rated at 70VA and is protected by a 3.5 amp circuit breaker (CB31). The 208/230 (Y) voltage transformers use primary voltage taps as shown in figure 3, while 460 (G) and 575 (J) voltage transformers use a single primary voltage tap.

#### 3-Control Transformer T1

All use a single line voltage to 24VAC transformer mounted in the control box. Transformer supplies power to control circuits in the unit. The transformer is rated at 92VA and is protected by a 6 amp circuit breaker (CB8). The 208/230 (Y) voltage transformers use primary voltage taps as shown in FIGURE 3, while 460 (G) and 575 (J) voltage transformers use a single primary voltage tap.

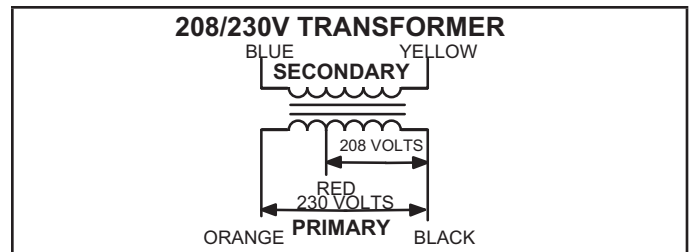

FIGURE 3

#### 4-Outdoor Fan Relay K10, K68

Outdoor fan relays K10 and K68 are DPDT relays with a 24VAC coil. In standard and high efficiency units, K10 and K68 energize condenser fans B4 and B5.

#### 5-Outdoor Fan Capacitors C1, C2

Fan capacitors C1 and C2 are used to assist in the start up of condenser fans B4 and B5. Capacitor size varies with unit tonnage and voltage.

LGT092-102 all voltages - 370V/10 MFD

LGT120-150 J volt - 370/10 MFD

LGT120-150 G volt - 370V/12.5 MFD

LGT120-150 Y volt - 370V/15 MFD

#### 6-C. A. I. Transformers T3 575V Units

All LGT 575 (J) voltage units use transformer T3. The auto voltage to 230VAC transformer is mounted in the control box. The transformer has an output rating of 0.5A. T3 transformer supplies 230 VAC power to combustion air blower motor (B6).

#### 7-Compressor Contactor K1, K2

All compressor contactors are three-pole, double-break contactors with 24VAC coils. K1 and K2 (both energized by A55) energize compressors B1 and B2.

#### 8-Burner Controls A3

A3 controls gas heat section burner controls. Burner controls are factory set and are not adjustable. The control makes three attempts at ignition and then locks out the system if ignition is not obtained after the third trial. Reset after lockout requires only breaking and remaking thermostat demand. The control shuts off gas flow immediately in the event of a gas or power failure. Upon restoration of gas and power, the control will restart the ignition sequence and continue until flame is established or system locks out. For a more detailed description see the Gas Heat Components section.

#### 9-Power Exhaust Relay K65 (PED units)

Power exhaust relay K65 is a N.O. DPDT relay with a 24VAC coil. K65 is used in all LGT units equipped with the optional power exhaust dampers. K65 is energized by the economizer control panel (A56), after the economizer dampers reach 50% open (adjustable in CORE). When K65 closes, the exhaust fan B10 is energized.

### 10-Unit Controller A55

The Unit Controller provides all unit control functions, unit status information, unit diagnostics, programmable parameters and USB verification and profile sharing. Refer to the Unit Controller guide provided with the unit. Thermostat wires are connected to J297 on the Unit Controller.

### 11-Terminal Block TB13

TB13 terminal block distributes line voltage power to the line voltage items in the unit.

### 12-Wireless Antenna

Wireless antenna is located above the return air compartment of the unit. FIGURE 4 shows location and FIGURE 5 shows cable routing. Please follow the CORE Controller setup guide included in the unit.

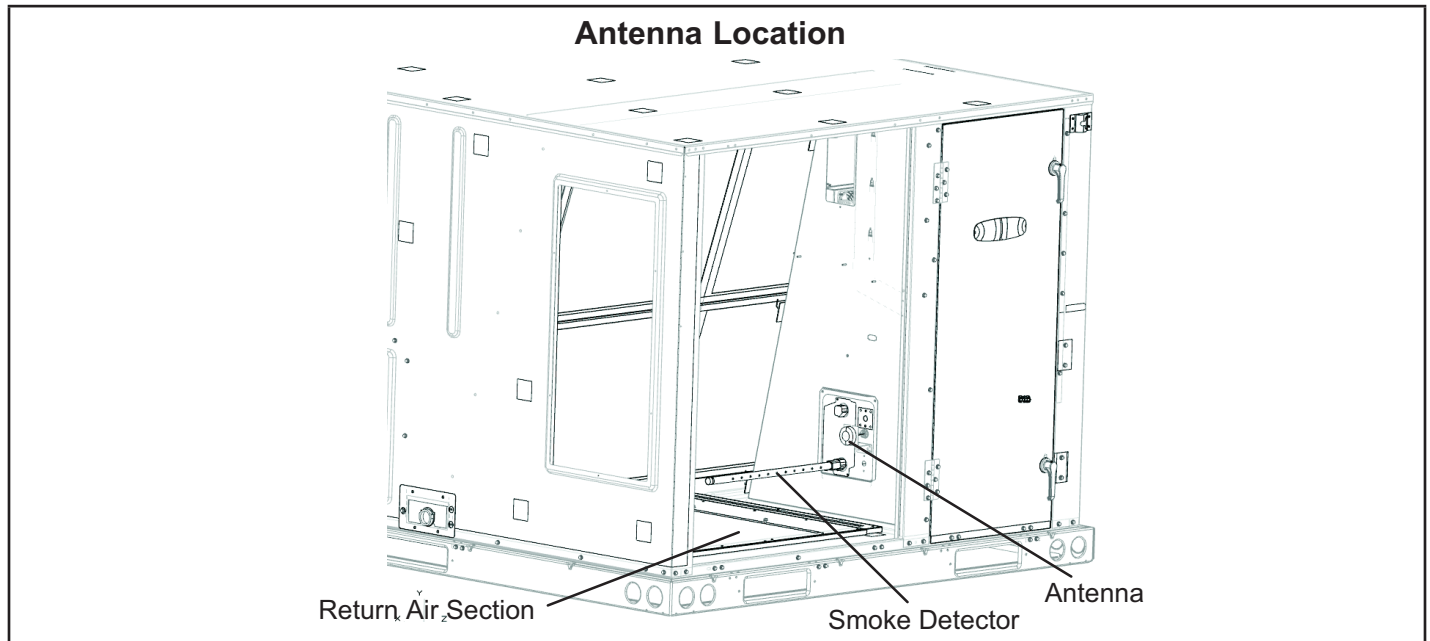

**FIGURE 4**

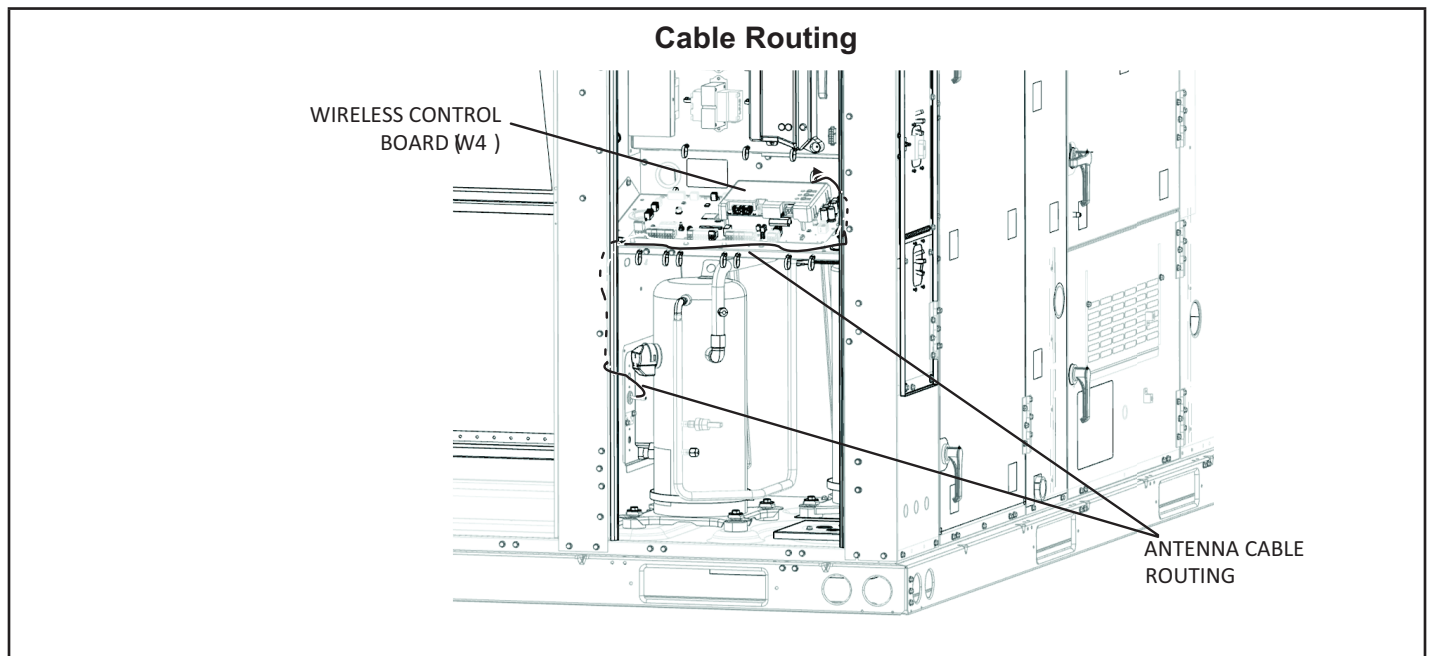

**FIGURE 5**

## Temperature Sensors

The return air (RT16) and discharge air (RT6) duct probes and the outdoor air (RT17) are all two wire thermistors. The resistance vs. temperature table is shown below:

### Relative Humidity Sensor - Optional

The indoor relative humidity sensor (A91) is an analog sensor with a 0-10VDC output over a relative humidity range of 0-100% relative humidity. The sensor is powered with 24VAC.

### Enthalpy Sensor - Optional

The optional enthalpy sensors (A7 and A63) used with the economizer have an output of 4-20mA.

The sensor is powered with 18VAC provided by M3 unit control.

### Economizer Differential Pressure Sensor - Optional

Rooftop units installed with Smart Airflow™ will have a Pressure Transducer (PT5) present in the economizer. PT5 requires 5VDC power supply (P266-5 and {P266-6) and gives 0.25 VDC to 4 VDC output (P266-4) corresponding to 0" water column and 2" water column respectively.

For all practical purposes the output should be less than 1.2" water column if not an error code is stored and service alarm output is turned on.

**TABLE 1**  
**Resistance vs. Temperature**

Temp. °F (°C)	Resistance +/-2%	Temperature °F (°C)	Resistance +/-2%	Temp. °F (°C)	Resistance +/-2%
-40 (-40)	335,671	40 (4.4)	26,106	90 (32.2)	7,332
-20 (-28.9)	164,959	50 (10)	19,904	100 (37.8)	5,826
0 (-17.8)	85,323	60 (15.6)	15,313	120 (48.9)	3,756
20 (-6.7)	46,218	70 (21.1)	11,884	130 (54.4)	3,047
30 (-1.1)	34,566	80 (26.7)	9,298		

### Room Sensors

Room sensor (A2) is a two-wire thermistor with 1k series resistor.

**TABLE 2**  
**Two-Wire Thermistor**

Temp. °F (°C)	Resistance +/-2%	Temperature °F (°C)	Resistance +/-2%	Temp. °F (°C)	Resistance +/-2%
40 (4.4)	27,102	60 (15.6)	16,313	80 (26.7)	10,299
45 (7.2)	23,764	65 (18.3)	14,474	85 (29.4)	9,249
50 (10)	20,898	70 (21.1)	12,882	90 (32.2)	8,529
55 (12.8)	18,433	75 (23.9)	11,498		

### Carbon Dioxide Sensor

The indoor carbon dioxide sensor (A63) is an analog sensor with a 0-10VDC output over a carbon dioxide range of 0-2000 ppm as shown in the following table. The sensor is powered with 24VAC.

**TABLE 3**  
**Carbon Dioxide Range**

Carbon Dioxide PPM	DC Voltage	Carbon Dioxide PPM	DC Voltage	Carbon Dioxide PPM	DC Voltage	Carbon Dioxide PPM	DC Voltage
0	0	600	3	1200	6	1800	9
200	1	800	4	1400	7	2000	10
400	2	1000	5	1600	8		

### VAV Supply Static Sensor

The supply duct differential static pressure sensor (A30) is an analog sensor with a 0-10VDC output over a range of 0-5"w.c as shown in the following table. The sensor is powered with 24VAC.

**TABLE 4**  
**Carbon Dioxide Range**

Pressure "w.c.	DC Voltage	Pressure "w.c.	DC Voltage	Pressure "w.c.	DC Voltage	Pressure "w.c.	DC Voltage
0	0	1.5	3	3	6	4.5	9
0.5	1	2	4	3.5	7	5	10
1	2	2.5	5	4	8		

## PLUMBING, COMPRESSOR AND REFRIGERANT CIRCUITS DETAIL

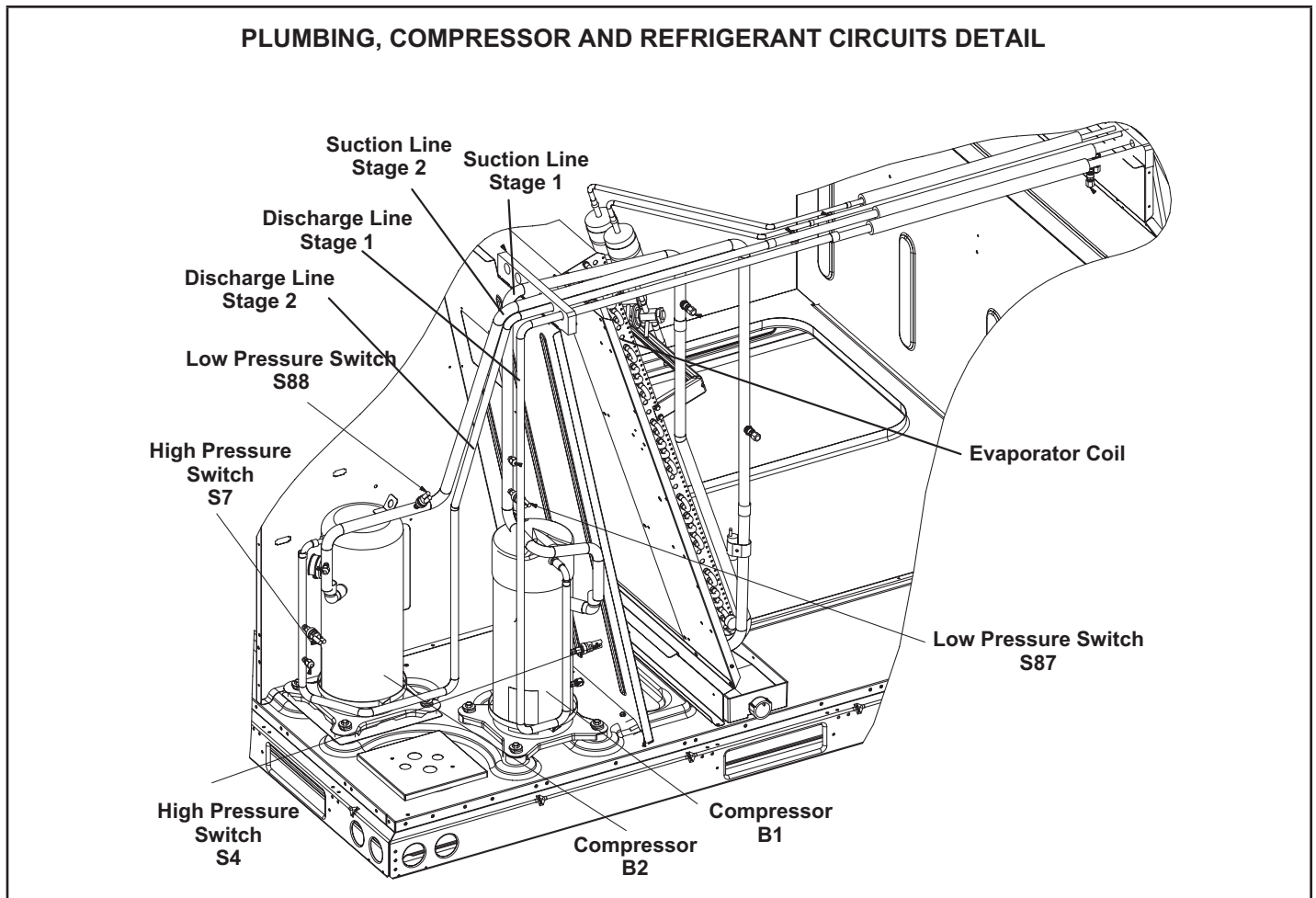

FIGURE 6

### B-Cooling Components

High efficiency units use independent cooling circuits consisting of separate compressors, condenser coils and evaporator coils. See FIGURE 6. Units are equipped with ECM direct drive blowers which draw air across the evaporator during unit operation.

On all units the evaporators are slab type and are row split. Each evaporator uses a thermostatic expansion valve as the primary expansion device.

In all units, each compressor is protected by a crankcase heater, high pressure switch and low pressure switch. Additional protection is provided by thermistors for low ambient control and freezing prevention.

Cooling may be supplemented by a factory- or field-installed economizer.

### 1-Compressors B1, B2

Units are equipped with two scroll compressors and two independent cooling circuits. B1 is 2-stage compressor, with L34 to switching between part load and full load, B2 is single stage compressor. Compressor capacity may vary from stage to stage. In all cases, the capacity of each compressor is added to reach the total capacity of the unit. See "SPECIFICATIONS" and "ELECTRICAL DATA" (table of contents) or compressor nameplate for compressor specifications.

## **⚠ IMPORTANT**

**Compressor two is the only component that must be checked to ensure proper phasing. Follow "COOLING START-UP" section of installation instructions to ensure proper compressor and blower operation.**

## **WARNING**

**Electrical shock hazard. Compressor must be grounded. Do not operate without protective coverover terminals. Disconnect power before removing protective cover. Discharge capacitors before servicing unit. Failure to follow these precautions could cause electrical shock resulting in injury or death.**

Each compressor is energized by a corresponding compressor contactor.

**NOTE**-Refer to the wiring diagram section for specific unit operation. If Interlink compressor replacement is necessary, call 1-800-453-6669.

## **IMPORTANT**

**Some scroll compressors have an internal vacuum protector that will unload scrolls when suction pressure goes below 20 psig. A hissing sound will be heard when the compressor is running unloaded. Protector will reset when low pressure in system rises above 40 psig. DO NOT REPLACE COMPRESSOR.**

### **2-Crankcase Heaters HR1, HR2**

All LGT units use insertion type heaters. Heater HR1 is installed around compressor B1 and heater HR2 is installed around compressor B2. Crankcase heater wattage varies by compressor size.

### **3-High Pressure Switches S4, S7**

The high pressure switch is an auto-reset SPST N.C. switch which opens on a pressure rise. All units are equipped with this switch. On fin/tube outdoor coils, the switch is located in the compressor discharge line. On aluminum outdoor coils, the switch is located on the liquid line in the blower section. Switches are wired in series with the compressor contactor coil.

On standard and high efficiency units, S4 (first circuit) and S7 (second circuit) are wired in series with the respective compressor contactor coils. On ultra high efficiency units, only S4 is used. S4 is located on the common compressor discharge line and is wired to both compressor contactors via the A55 Unit Controller.

When discharge pressure rises to  $640 \pm 20$  psig ( $4412 \pm 138$  kPa) (indicating a problem in the system) the switch opens and the respective compressor is de-energized (the economizer can continue to operate). When discharge pressure drops to  $475 \pm 20$  psig ( $3275 \pm 138$  kPa) the pressure switch will close.

The A55 Unit Controller has a three-strike counter before locking out. This means the control allows three high pressure trips per one thermostat demand. The control can be reset by breaking and remaking the thermostat demand or manually resetting the control.

### **4-Filter Drier**

LGT units have a filter drier located in the liquid line of each refrigerant circuit. The drier removes contaminants and moisture from the system.

### **5-Low Pressure Switches S87, S88**

The low pressure switch is an auto-reset SPST N.O. switch (held N.C. by refrigerant pressure) which opens on a pressure drop. All units are equipped with this switch. The switch is located in the compressor suction line. S87 (compressor one) and S88 (compressor two) are wired to A55 Unit Controller. A55 governs the low pressure switches by shunting the switches during start up until pressure is stabilized. After the shunt period, the control has a three-strike counter, during first thermostat demand, before the compressor is locked out. The control is reset by breaking and remaking the thermostat demand or manually resetting the control.

When suction pressure drops to  $40 \pm 5$  psig ( $276 \pm 34$  kPa), (indicating low pressure), the switch opens and the compressor( s) is(are) de-energized. The switch automatically resets when pressure in the suction line rises to  $90 \pm 5$  psig ( $620 \pm 34$  kPa) due to many causes such as refrigerant being added.

### **6-Condenser Fans B4 and B5**

See SPECIFICATIONS tables at the front of this manual for specifications of condenser fans used in all units. All condenser fans have single-phase motors. The fan assembly may be removed for servicing and cleaning.

### **7-Temperature Sensors RT46, RT47, RT48 & RT49**

Units are equipped with four factory-installed thermistors (RT46-RT49) located on different points on the refrigerant circuit.

The thermistors provide the Unit Controller with constant temperature readings of four specific locations on the refrigeration circuit. These temperatures are used as feedback in certain modes of unit operation.

Each thermistor must be specifically placed for proper unit operation and to initiate valid alarms. See FIGURE 7 and FIGURE 8 proper locations.

**THERMISTOR LOCATION - EVAPORATOR COIL  
RT46, RT47**

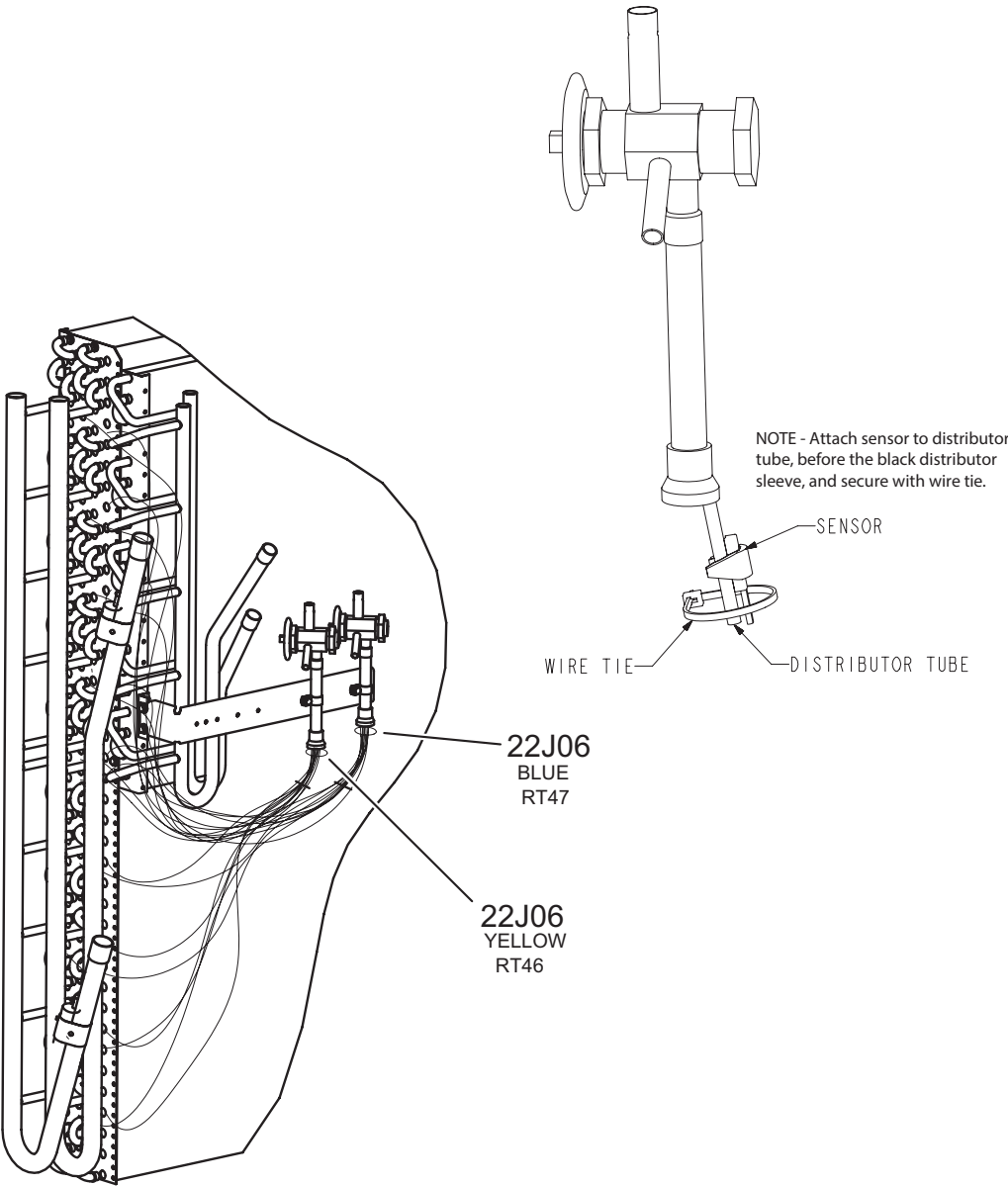

**FIGURE 7**

**THERMISTOR LOCATION - CONDENSER COIL  
RT48, RT49**

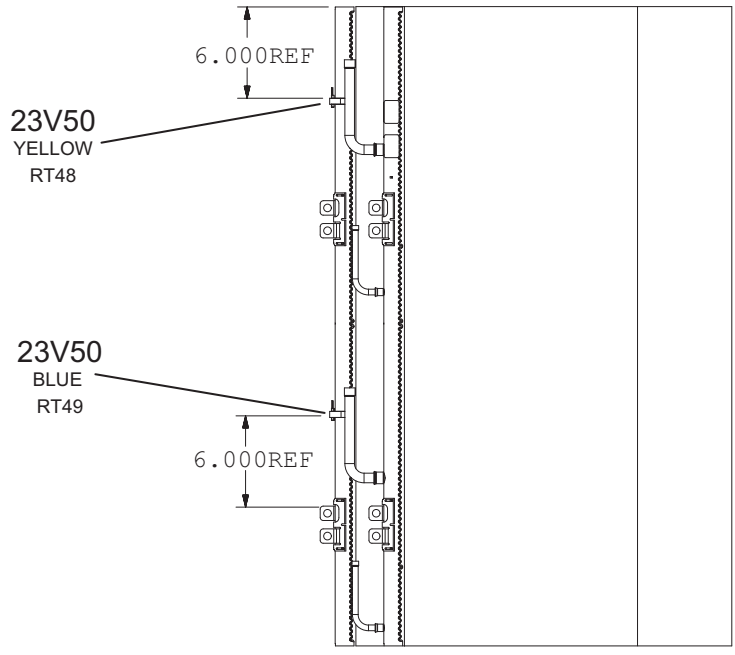
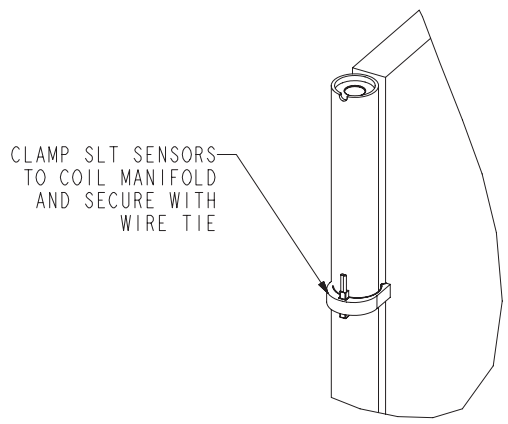

DETAILS NOT TO SCALE

**FIGURE 8**

## 8-RDS Sensors

Units are equipped with factory-installed RDS Sensors located on different points on the unit. The RDS sensors provide the Unit Controller with continuous readings for leaked refrigerant concentration levels and sensor health status (Good or Fault). These readings are used to modify unit operation to disperse the leaked refrigerant and to remove possible ignition sources. In addition, the Unit Controller uses these readings to initiate alarms to alert the operator of a refrigerant leak or faulty sensor(s).

Each sensor must be specifically placed for proper unit operation and to initiate valid alarms. To identify sensor locations see FIGURE 9.

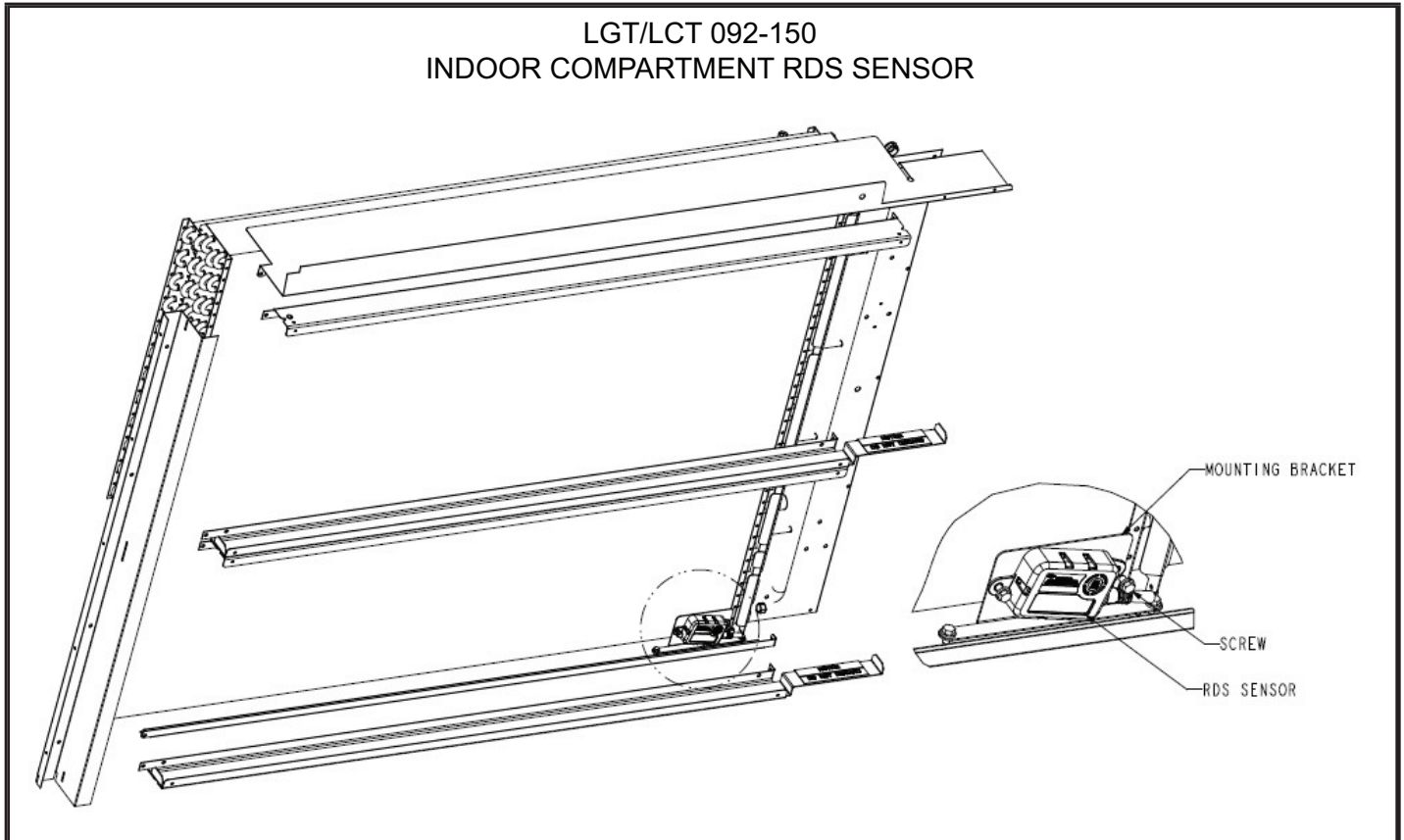

**FIGURE 9**

## C-Blower Compartment

The blower compartment is located between the evaporator coil and the condenser coil section. The blower assembly is secured to a sliding frame which allows the blower motor assembly to be pulled out of the unit.

Units are equipped with variable speed, direct drive blowers. The supply CFM can be adjusted by changing the percentage of motor output using the Unit Controller settings. Measure the intake air CFM and adjust the RPM% to get design-specified supply air CFM.

### 1-Blower Wheels

Units are be equipped with a backward inclined blower wheel. See "SPECIFICATIONS" at the front this manual for more detail.

### 2-Indoor Blower Motor B3

Units are equipped with a direct drive blower assembly with a three-phase, variable speed, direct drive blower motor.

All motor specifications are listed in the SPECIFICATIONS (table of contents) in the front of this manual. Units may be equipped with motors manufactured by various manufacturers, therefore electrical FLA and LRA specifications will vary. See unit rating plate for information specific to your unit.

The Unit Controller checks the incoming power during start-up. If the voltage or phase is incorrect, the Unit Controller will display an alarm and the unit will not start.

### A-Blower Operation

Refer to the Unit Controller Setup Guide to energize blower. Use the mobile service app menu; see SERVICE > TEST.

In both thermostat and zone control mode, the Unit Controller will stage the blower between low and high speed. In zone sensor control mode, the Unit Controller will vary (VAV) the blower between low and high speed.

## WARNING

- 1-Make sure that unit is installed in accordance with the installation instructions and applicable codes.
- 2-Inspect all electrical wiring, both field- and factory-installed, for loose connections. Tighten as required.
- 3-Check to ensure that refrigerant lines do not rub against the cabinet or against other refrigerant lines.
- 4-Check voltage at disconnect switch. Voltage must be within range listed on nameplate. If not, consult power company and have voltage condition corrected before starting unit.
- 5-Make sure filters are new and in place before start-up.

Initiate blower only (G) demand at thermostat according to instructions provided with thermostat. Unit will cycle on thermostat demand. The following steps apply to applications using a typical electro-mechanical thermostat.

- 1 - Blower operation is manually set at the thermostat subbase fan switch. With fan switch in ON position, blowers will operate continuously.
- 2 - With fan switch in AUTO position, the blowers will cycle with demand. Blowers and entire unit will be off when system switch is in OFF position.

**NOTE** - Blower operation mode can also be initiated by the mobile service app.

Direct-drive motor may not immediately stop when power is interrupted to the Unit Controller. Disconnect unit power before opening the blower compartment. The Controller's digital inputs must be used to shut down the blower. See Unit Controller manual for operation sequences.

### B-Blower Access

The blower assembly is secured to a sliding frame which allows the blower assembly to be pulled out of the unit. See FIGURE 11.

- 1 - Loosen the reusable wire tie which secures the controls and high voltage blower wiring to the blower housing. Disconnect the pressure sensor low voltage wire harness.
- 2 - Remove and retain screws on either side (and on the front for direct drive) of sliding frame. Use the metal handle to pull frame toward outside of unit.
- 3 - Slide frame back into original position when finished servicing. Reattach the blower wiring in the previous location using the wire tie. Reconnect pressure sensor low voltage wire harness.
- 4 - Replace retained screws.

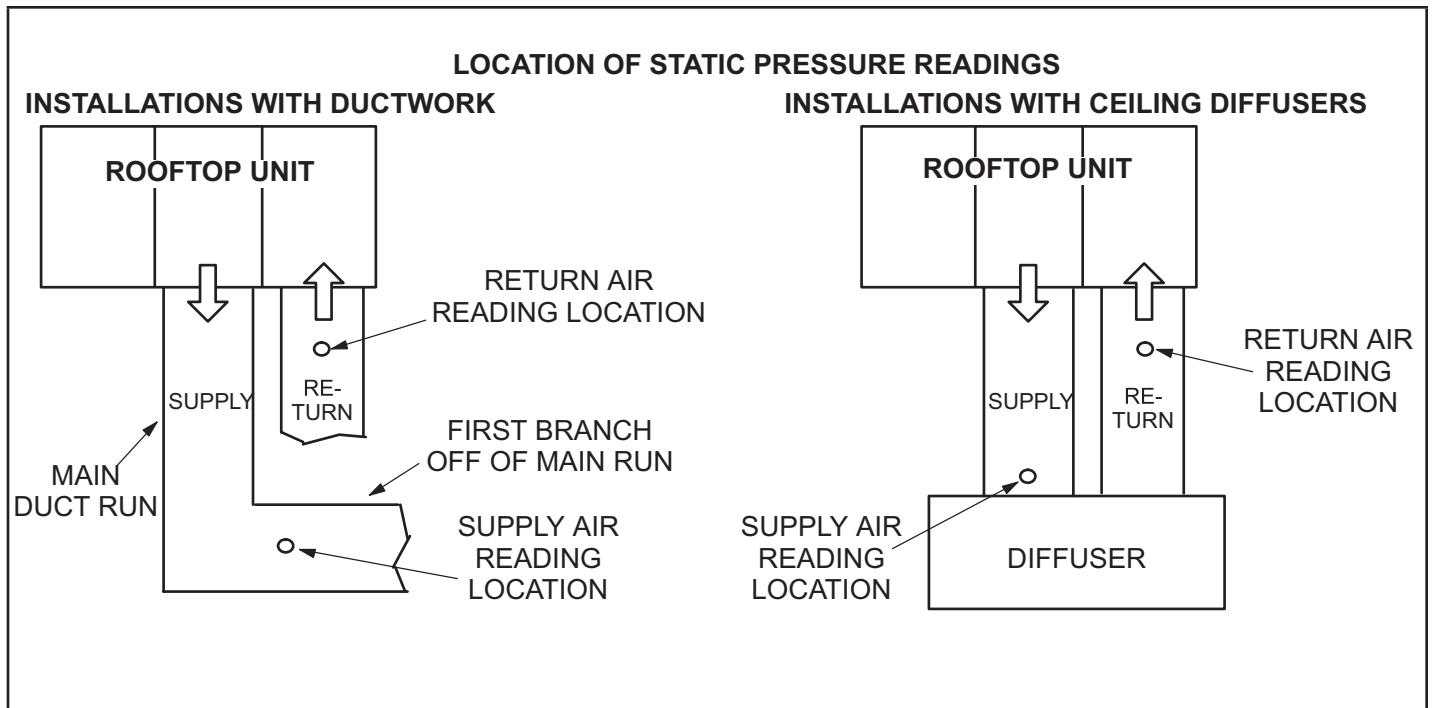

**FIGURE 10**

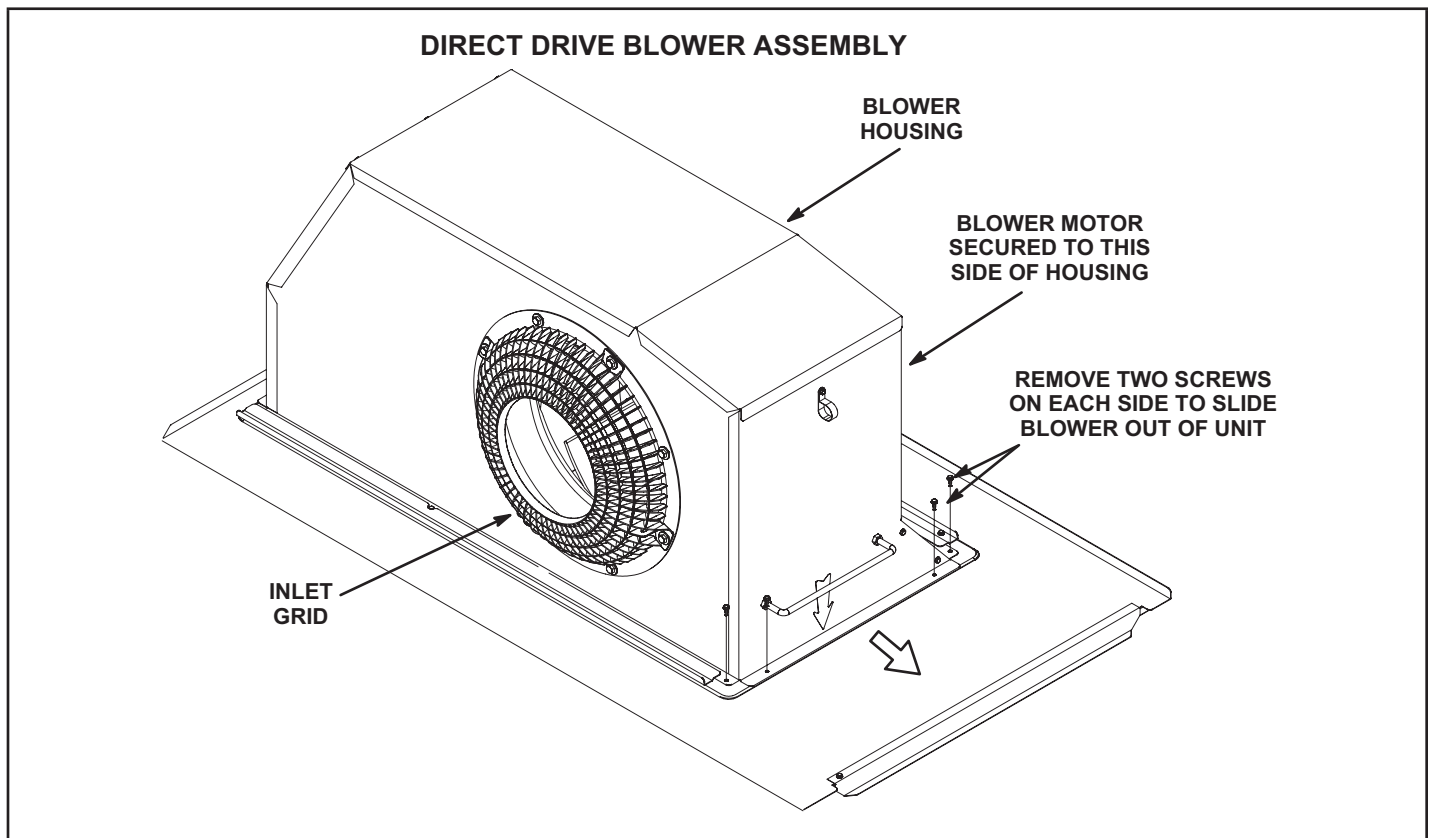

**FIGURE 11**

The supply CFM can be adjusted by changing the percentage of motor output using the Unit Controller settings. Refer to TABLE 5 for menu paths and default settings.. Record any RPM% changes on the parameter settings label located on the inside of the compressor access panel.

Use the mobile service app to navigate to the SET-UP>TEST & BALANCE>BLOWER menu. After the new RPM% values are entered, select START CALIBRATION. The blower calibration status is displayed as a % complete. Upon successful completion, the mobile service app will display CALIBRATION SUCCESS and go back to the blower calibration screen.

<b>⚠ CAUTION</b>
<b>The BLOWER CALIBRATION process starts the indoor blower at operational speeds and moves the economizer damper blades. Before starting this process, replace any access panels and close all unit doors except compressor compartment door.</b>

**IMPORTANT** - The default value for Cooling Low motor speed is lower than a traditional single- or two-speed unit. If operating the unit with a 2- or 3-stage controller (2- or 3-stage thermostat, DDC controller, etc.), it is recommended to increase the Cooling Low CFM default value to a suitable level for part load cooling (typically 60% of full load CFM).

Blower calibration is required only on units that are newly installed or if there is a change in the duct work or air filters after installation..

**TABLE 5  
DIRECT DRIVE PARAMETER SETTINGS - 581102-01**

Parameter	Field Setting	Description
<b>Note: Any changes to Smoke CFM setting must be adjusted before the other CFM settings. Use SETTINGS &gt; RTU OPTIONS &gt; EDIT PARAMETERS = 12 for EBM, 6 for ECM</b>		
BLOWER SMOKE CFM	%	Percentage of RPM for blower smoke speed.
<b>SETUP &gt; TEST &amp; BALANCE &gt; BLOWER</b>		
BLOWER HEATING HIGH CFM	%	Percentage of RPM for blower heating high speed.
BLOWER HEATING LOWCFM	%	Percentage of RPM for blower heating low speed (P volt gas heat only).
BLOWER COOLING HIGH CFM	%	Percentage of RPM for blower cooling high speed.
BLOWER COOLING LOW CFM	%	Percentage of RPM for blower cooling low speed and vent speed for standard static blowers.
BLOWER VENTILATION CFM	%	Percentage of RPM for high static blower ventilation speed.
<b>SETUP &gt; TEST &amp; BALANCE &gt; DAMPER</b>		
BLOWER HIGH CFM DAMPER POS %	%	Minimum damper position for high speed blower operation. Default 0%.
BLOWER LOW CFM DAMPER POS %	%	Minimum damper position for low speed blower operation. Default 0%.
POWER EXHAUST DAMPER POS %	%	Minimum damper position for low power exhaust operation. Default 50%.
<b>SETTINGS &gt; RTU OPTIONS &gt; EDIT PARAMETERS = 216</b>		
POWER EXHAUST DEADBAND %	%	Deadband % for power exhaust operation. Default 10%.
<b>SETTINGS &gt; RTU OPTIONS &gt; EDIT PARAMETERS = 10 (Applies to Thermostat Mode ONLY)</b>		
FREE COOLING STAGE-UP DELAY	sec	Number of seconds to hold blower at low speed before switching to blower at high speed. Default 300 seconds.

**Installer:** Record any parameter changes under “Field Setting” column. Settings need to be recorded by installer for use when Unit Controller is replaced or reprogrammed.

## D-GAS HEAT COMPONENTS

### 1-Control Box Components A3, A55, T3, K13

⚠ WARNING



**Shock hazard. Spark related components contain high voltage which can cause personal injury or death. Disconnect power before servicing. Control is not field repairable. Unsafe operation will result. If control is inoperable, simply replace the entire control.**

#### Burner Ignition Control A3

The ignition controls are located in the heat section areas below the compressors. The controls are manufactured UTEC. See TABLE 6 for LED codes.

The ignition control provides three main functions: gas valve control, ignition and flame sensing. The unit will usually ignite on the first attempt; however, the ignition attempt sequence provides three trials for ignition before locking out. The lockout time for the control is 5 minutes. After lockout, the ignition control automatically resets and provides three more attempts at ignition.

Manual reset after lockout requires breaking and remaking power to the ignition control. See FIGURE 12 for a normal ignition sequence and FIGURE 13 for the ignition attempt sequence with retrials (nominal timings given for simplicity). Specific timings for the ignition controls are shown in FIGURE 14.

**TABLE 6**

LED Flashes	Indicates
Slow Flash	Control ok, no call for heat
Fast Flash	Control ok, call for heat present.
Steady Off	Internal control fault or no power
Steady On Failure	Control internal failure
1 Flash	Rollout switch open
2 Flashes	Limit open or lockout from too many tries during a single heat demand
3 Flashes	Pressure switch open with inducer on/ open during 5 minute inducer off time.
4 Flashes	Ignition lockout from no flame detected or from too many flame losses.
5 Flashes	Flame sensed out of sequence
6 Flashes	Pressure switch closed with inducer off
7 Flashes	Gas valve relay failure
8 Flashes	Lockout due to too many pressure switch openings during one heat demand

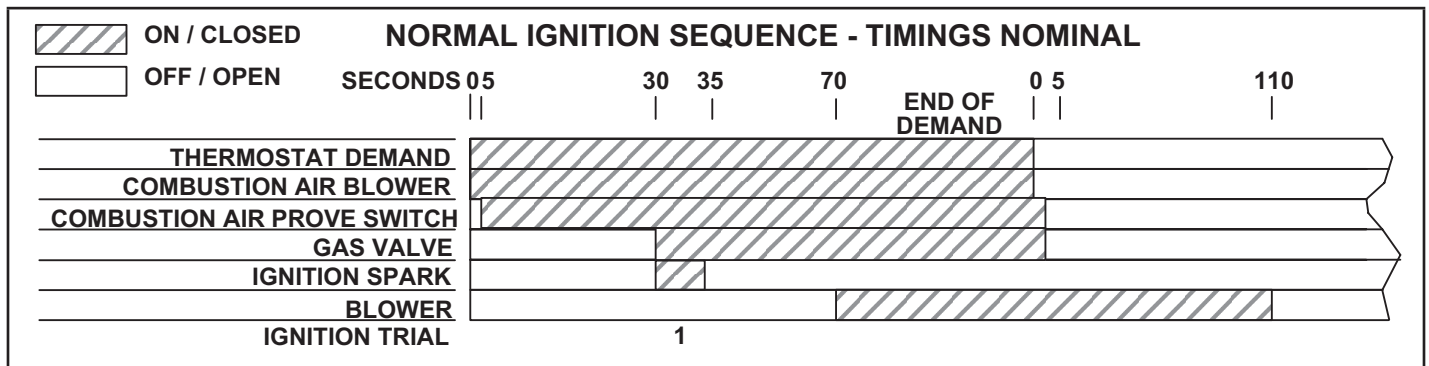

**FIGURE 12**

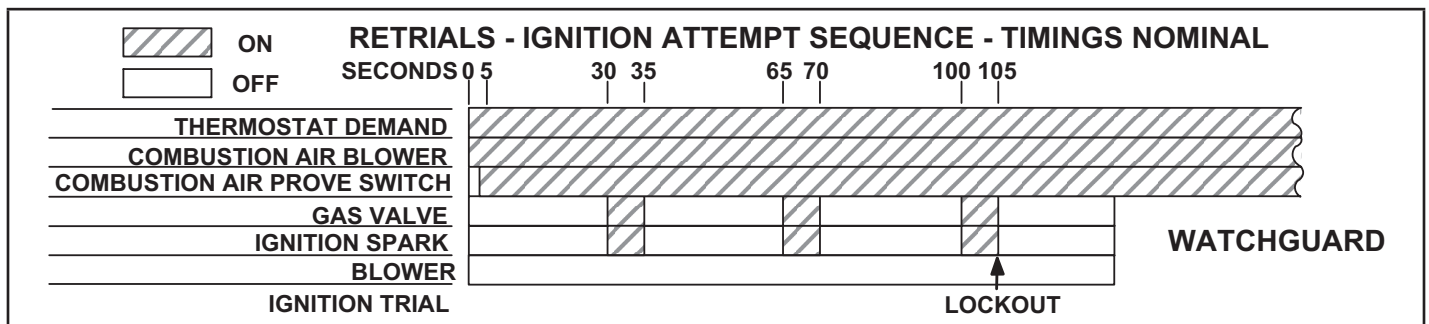

**FIGURE 13**

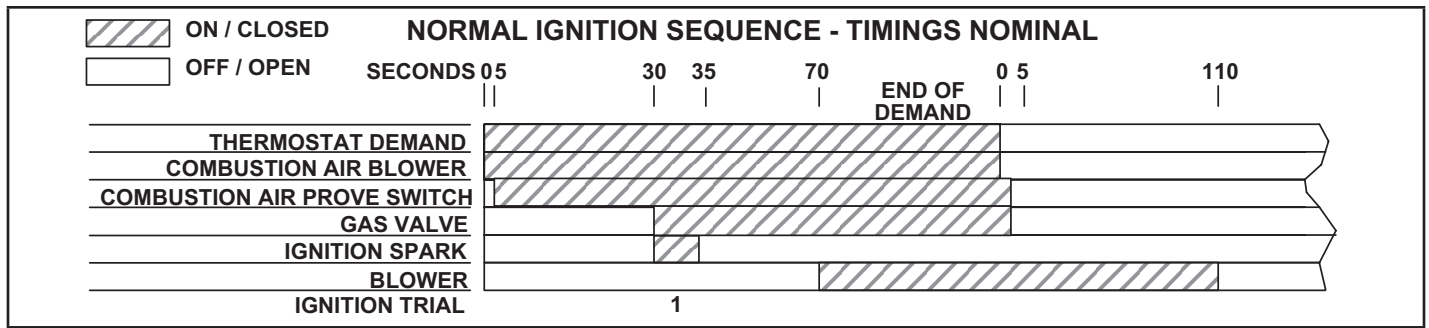

FIGURE 14

Flame rectification sensing is used on all units. Loss of flame during a heating cycle is indicated by an absence of flame signal (0 microamps). If this happens, the control will immediately restart the ignition sequence and then lock out if ignition is not gained after the third trial. See System Service Checks section for flame current measurement.

The control shuts off gas flow immediately in the event of a power failure. Upon restoration of gas and power, the control will restart the ignition sequence and continue until flame is established or system locks out.

On a heating demand, the ignition control is energized by the A55 Unit Controller. The ignition control then allows 30 to 40 seconds for the combustion air blower to vent exhaust gases from the burners. When the combustion air blower is purging the exhaust gases, the combustion air prove switch is closing proving that the combustion air blower is operating before allowing the ignition control to energize. When the combustion air prove switch is closed and the delay is over, the ignition control activates gas valve, the spark electrode and the flame sensing electrode. Sparking stops immediately after flame is sensed. The combustion air blower continues to operate throughout the heating demand. If the flame fails or if the burners do not ignite, the ignition control will attempt to ignite the burners up to two more times. If ignition cannot be obtained after the third attempt, the control will lock out. The ignition control is not adjustable.

**2-Heat Exchanger (FIGURE 15)**

The LGT units use cluster type inshot burners with matching tubular aluminized (stainless steel is an option) steel heat exchangers and two-stage redundant gas valves. Units are equipped with one eleven tube/burner for high heat, one nine tube/burner for medium heat, and one six tube/burner for standard heat. Burners use a burner venturi to mix gas and air for proper combustion.

Combustion takes place at each tube entrance. As hot combustion gases are drawn upward through each tube by the combustion air blower, exhaust gases are drawn out the top and fresh air/gas mixture is drawn in at the bottom. Heat is transferred to the air stream from all surfaces of the heat exchanger tubes. The supply air blowers, controlled by the A55 Unit Controller, force air across all surfaces of the tubes to extract the heat of combustion. The shape of the tubes ensures maximum heat exchange. The gas valves accomplish staging by allowing more or less gas to the burners as called for by heating demand.

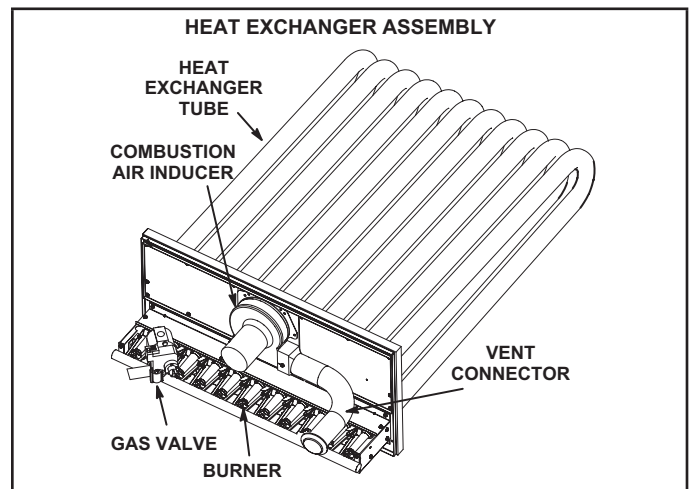

FIGURE 15

### 3-Burner Box Assembly (FIGURE 16)

The burners are controlled by the spark electrode, flame sensing electrode, gas valve and combustion air blower. The spark electrode, flame sensing electrode and gas valve are directly controlled by ignition control. Ignition control and combustion air blower is controlled by A55 Unit Controller.

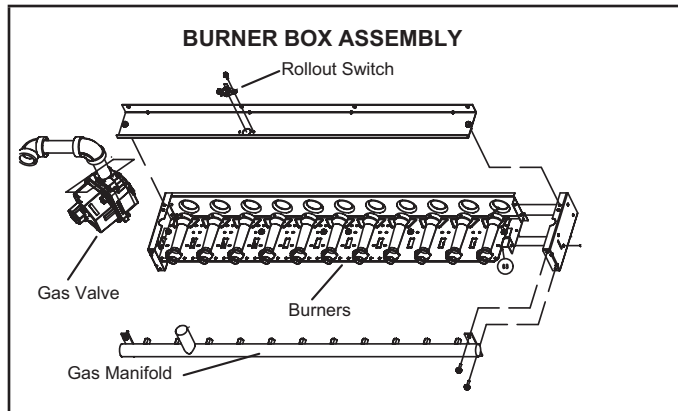

FIGURE 16

#### Burners

All units use cluster type inshot burners (FIGURE 17). Burners are factory set and do not require adjustment. A peep hole with cover is furnished in the heating access panel for flame viewing. Always operate the unit with the access panel in place.

Burners can be removed for service as an assembly. Burner maintenance and service is detailed in the SERVICE CHECKS section of this manual.

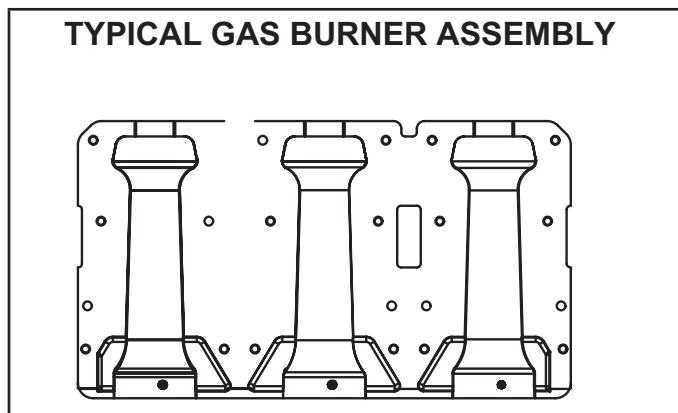

FIGURE 17

#### Orifice

Each burner uses an orifice (FIGURE 18) which is precisely matched to the burner input. Install only the orifices with the same threads. The orifice is threaded into the burner manifold. The burner is supported by the orifice and will easily slide off for service.

**NOTE**-Do not use thread sealing compound on the orifices. Using thread sealing compound may plug the orifices.

Each orifice and burner are sized specifically to the unit. Refer to ProductZone@www.davenet.com for correct sizing information.

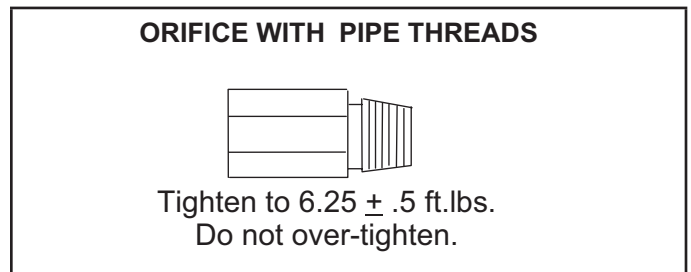

FIGURE 18

#### 4-Primary High Temperature Limits S10

S10 is the primary high temperature limit and is located on the blower deck to the right of the blower deck.

Primary limit S10 is wired to the A55 Unit Controller which energizes burner 1 control (A3). Its N.C. contacts open to de-energize the ignition control when excessive temperature is reached in the blower compartment. If the limit trips the blower will be energized. Limit settings are factory set and cannot be adjusted. If limit must be replaced, the same type and set point must be used.

### 5-Flame Roll-out Limit S47

Flame roll-out limit S47 is a SPST N.C. high temperature limit located as shown in figure 19. S47 is wired to the A55 Unit Controller. When S47 senses flame roll-out (indicating a blockage in the combustion air passages), the flame rollout limit trips and the ignition control immediately closes the gas valve.

Limit S47 is factory preset to open at  $290F \pm 12F$  ( $143.3C \pm 6.7C$ ) on a temperature rise. All flame roll-out limits are manual reset.

### 6-Combustion Air Prove Switch S18

S18 is a SPST N.O. switch which monitors combustion air inducer operation. See FIGURE 19 for location. Switch S18 is wired to the A55 Unit Controller.

The switch closes on a negative pressure fall. This negative pressure fall and switch actuation allows the ignition sequence to continue (proves, by closing, that the combustion air inducer is operating before allowing the gas valve to open.) The combustion air prove switch is factory set and not adjustable. The switch will automatically open on a pressure rise (less negative pressure). S18 closes at  $0.25 \pm 5$  in.w.c. ( $62.3 \pm 12.4$  Pa) and opens at  $0.10 \pm 5$  in.w.c. ( $24.8 \pm 12.4$ Pa)

### 7-Combustion Air Inducer B6

The combustion air inducer provides fresh air to the burner while clearing the combustion chamber of exhaust gases. See FIGURE 19 for the inducer location. The inducer is energized by the A55 Unit Controller via K13 relay.

The inducer uses a 208/230V single-phase PSC motor and a 4.81in. x 1.25in. (122mm x 32mm) blower wheel. The motor operates at 3200RPM and is equipped with auto-reset overload protection. Blower is supplied by various manufacturers. Ratings may vary by manufacturer. Specific blower electrical ratings can be found on the unit rating plate.

All combustion air blower motors are sealed and cannot be oiled. The blower cannot be adjusted but can be disassembled for cleaning.

### 8-Combustion Air Motor Capacitor C3

Combustion air inducer B6 requires a run capacitor rated at 3 MFD and 370VAC.

### 9-Gas Valves GV1

Gas valve GV1 is a two-stage redundant valve.. On first stage (low fire) is quick opening (on and off in less than 3 seconds). Second stage is slow opening (on to high fire pressure in 40 seconds and off to low fire pressure in 30 seconds). On a call for first stage heat (low fire), the valve is energized by the ignition control simultaneously with the spark electrode. On a call for second stage heat (high fire), the second stage operator is energized directly from A55.

The valve is adjustable for high fire only. Low fire is not adjustable. A manual shut-off knob is provided on the valve for shut-off. Manual shut-off knob immediately closes both stages without delay. FIGURE 20 shows gas valve components. TABLE 7 shows factory gas valve regulation for LGT units.

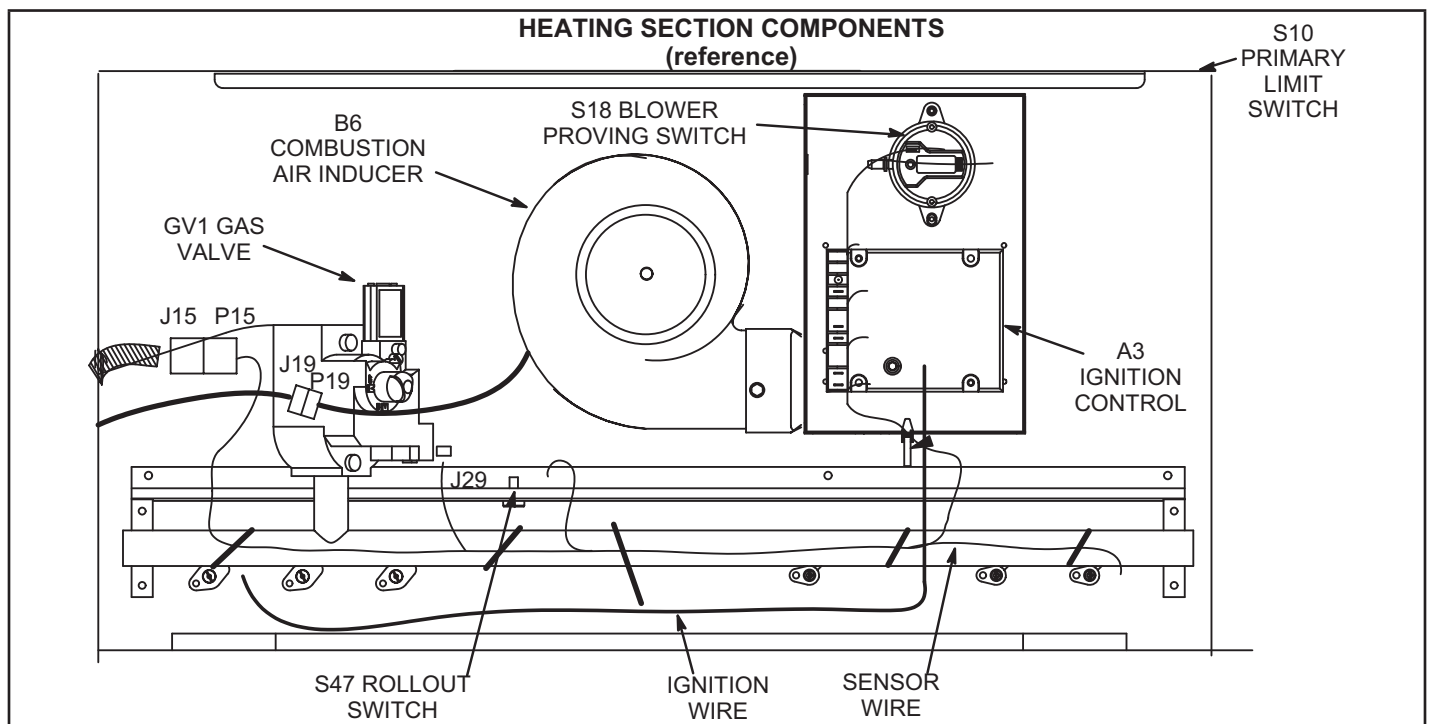
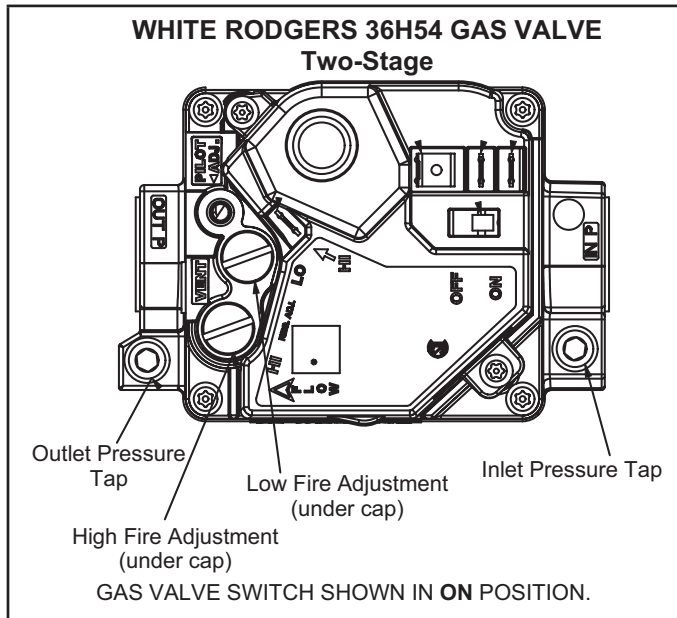

FIGURE 19

**TABLE 7**  
**GAS VALVE REGULATION FOR LGT UNITS**

Max Inlet Pressure "W.C."	Operating Pressure "W.C. (outlet) Factory Setting			
	Natural		L.P. Propane	
	Low	High	Low	High
13.0	1.6±0.2	3.7±0.3	5.5±0.3	10.5±0.5



**FIGURE 20**

### 10-Spark Electrodes

An electrode assembly is used for ignition spark. Two identical electrodes are used (one for each gas heat section). The electrode is mounted through holes on the left-most end of the burner support. The electrode tip protrudes into the flame envelope of the adjacent burner. The electrode assembly is fastened to burner supports and can be removed for service without removing any part of the burners.

During ignition, spark travels through the spark electrode (FIGURE 21) and ignites the left burner. Flame travels from burner to burner until all are lit.

The spark electrode is connected to the ignition control by a 8 mm silicone-insulated stranded high voltage wire. The wire uses 1/4" (6.35 mm) female quick connect on the electrode end and female spark plug-type terminal on the ignition control end

**NOTE-IN ORDER TO MAXIMIZE SPARK ENERGY TO ELECTRODE, HIGH VOLTAGE WIRE SHOULD TOUCH UNIT CABINET AS LITTLE AS POSSIBLE.**

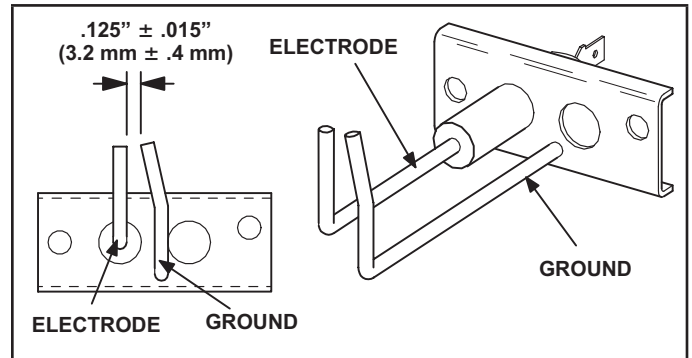

**FIGURE 21**

### 11-Flame Sensors

A flame sensor is located on the right side of each burner support. The sensor is mounted through a hole in the burner support and the tip protrudes into the flame envelope of the right most burner. The sensor assembly is fastened to burner supports and can be removed for service without removing any part of the burners.

When flame is sensed by the flame sensor (indicated by microamp signal through the flame) sparking stops immediately.

During operation, flame is sensed by current passed along the ground electrode (located on the spark electrode), through the flame and into the sensing electrode. The ignition control allows the gas valve to stay open as long as a flame signal (current passed through the flame) is sensed.

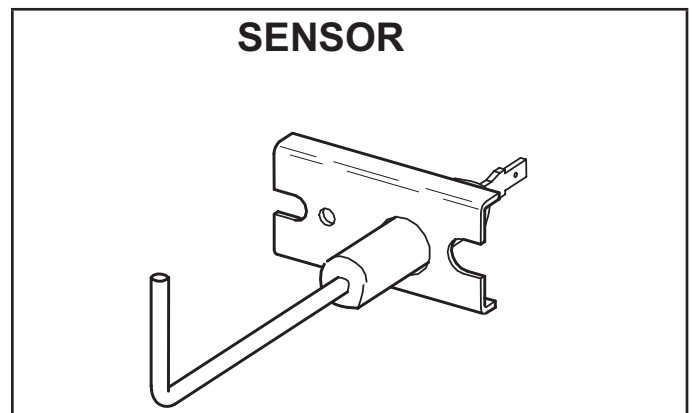

**FIGURE 22**

## II-PLACEMENT AND INSTALLATION

Make sure the unit is installed in accordance with the installation instructions and all applicable codes. See accessories section for conditions requiring use of the optional roof mounting frame (C1CURB10).

## III-CHARGING

### A-Preliminary and Seasonal Checks

- 1 - Make sure that unit is installed in accordance with the installation instructions and applicable codes.
- 2 - Inspect all electrical wiring, both field and factory installed, for loose connections. Tighten as required.
- 3 - Check to ensure that refrigerant lines do not rub against the cabinet or against other refrigerant lines.
- 4 - Check voltage at disconnect switch. Voltage must be within range listed on nameplate. If not, consult power company and have voltage condition corrected before starting unit.
- 5 - Refer to unit diagram located on inside of compressor access door for unit wiring.
- 6 - Adjust blower belt according to "Blower Operation and Adjustments" section.
- 7 - Make sure filters are in place before start-up.

### B-Refrigerant Charge and Check - All-Aluminum Coil

**WARNING**-Do not exceed nameplate charge under any condition.

This unit is factory charged and should require no further adjustment. If the system requires additional refrigerant, reclaim the charge, evacuate the system, and add required nameplate charge.

Refrigerant Charge R-454B		
Unit	M <sub>c</sub> (lbs)	M <sub>c</sub> (kg)
LGT092 STG 1	6.25	2.83
LGT092 STG 2	5.88	2.67
LGT102 STG 1	6.25	2.83
LGT102 STG 2	5.88	2.67
LGT120 STG 1	5.88	2.67
LGT120 STG 2	5.88	2.67
LGT150 STG 1	5.75	2.61
LGT150 STG 2	6.25	2.83
LGT092 W/ Humidrol STG 1	6.5	2.95
LGT092 W/ Humidrol STG 2	5.88	2.67
LGT102 W/ Humidrol STG 1	6.5	2.95
LGT102 W/ Humidrol STG 2	5.88	2.67
LGT120 W/ Humidrol STG 1	6.25	2.83
LGT120 W/ Humidrol STG 2	5.88	2.67
LGT150 W/ Humidrol STG 1	6.13	2.78
LGT150 W/ Humidrol STG 2	6.25	2.83

When breaking into the refrigerant circuit to make repairs – or for any other purpose – conventional procedures shall be used. However, for flammable refrigerants it is important that best practice be followed and, since flammability is a consideration, the following procedure shall be adhered to:

- Safely remove refrigerant following local and national regulations,
- Evacuate the circuit,
- Purge the circuit with inert gas,
- Evacuate,
- Purge with inert gas,
- Open the circuit

The refrigerant charge shall be recovered into the correct recovery cylinders if venting is not allowed by local and national codes. For appliances containing flammable refrigerants, the system shall be purged with oxygen-free nitrogen to render the appliance safe for flammable refrigerants. This process might need to be repeated several times. Compressed air or oxygen shall not be used for purging refrigerant systems. Refrigerant purging shall be achieved by breaking the vacuum in the system with oxygen-free nitrogen and continuing to fill until the working pressure is achieved, then venting to atmosphere, and finally pulling down to a vacuum. This process shall be repeated until no refrigerant is within the system. When the final oxygen-free nitrogen charge is used, the system shall be vented down to atmospheric pressure to enable work to take place. Ensure that the outlet for the vacuum pump is not close to any potential ignition sources and that ventilation is available.

In addition to conventional charging procedures, the following requirements shall be followed.

- Ensure that contamination of different refrigerants does not occur when using charging equipment. Hoses or lines shall be as short as possible to minimize the amount of refrigerant contained in them.
- Cylinders shall be kept in an appropriate position according to the instructions.
- Ensure that the refrigerating unit is earthed prior to charging the system with refrigerant.
  - Label the system when charging is complete (if not already).
  - Extreme care shall be taken not to overfill the refrigerating unit.

Prior to recharging the system, it shall be pressure-tested with the appropriate purging gas. The system shall be leak-tested on completion of charging but prior to commissioning. A follow up leak test shall be carried out prior to leaving the site.

- When removing refrigerant from a system, either for servicing or decommissioning, it is recommended good practice that all refrigerants are removed safely. When transferring refrigerant into cylinders, ensure that only appropriate refrigerant recovery cylinders are employed. Ensure that the correct number of cylinders for holding the total system charge is available. All cylinders to be used are designated for the recovered refrigerant and labelled for that refrigerant (i. e. special cylinders for the recovery of

refrigerant). Cylinders shall be complete with pressure-relief valve and associated shut-off valves in good working order. Empty recovery cylinders are evacuated and, if possible, cooled before recovery occurs.

- The recovery equipment shall be in good working order with a set of instructions concerning the equipment that is at hand and shall be suitable for the recovery of all appropriate refrigerants including, when applicable, flammable refrigerants. In addition, a set of calibrated weighing scales shall be available and in good working order. Hoses shall be complete with leak-free disconnect couplings and in good condition. Before using the recovery machine, check that it is in satisfactory working order, has been properly maintained and that any associated electrical components are sealed to prevent ignition in the event of a refrigerant release. Consult manufacturer if in doubt.
- The recovered refrigerant shall be returned to the refrigerant supplier in the correct recovery cylinder, and the relevant waste transfer note arranged. Do not mix refrigerants in recovery units and especially not in cylinders.
- If compressors or compressor oils are to be removed, ensure that they have been evacuated to an acceptable level to make certain that flammable refrigerant does not remain within the lubricant. The evacuation process shall be carried out prior to returning the compressor to the suppliers. Only electric heating to the compressor body shall be employed to accelerate this process. When oil is drained from a system, it shall be carried out safely.

**NOTE** - System charging is not recommended below 60F (15C). In temperatures below 60F (15C), the charge must be weighed into the system.

If weighing facilities are not available, or to check the charge, use the following procedure:

**IMPORTANT** - Charge unit in standard cooling mode.

- 1 - Make sure outdoor coil is clean. Attach gauge manifolds and operate unit at full CFM in cooling mode with economizer disabled until system stabilizes (approximately five minutes). Make sure all outdoor air dampers are closed. Operate the unit in cooling mode at high speed using the following mobile service app menu path:

RTU MENU > COMPONENT TEST > COOLING > COOLING STAGE 3

- 2 - Compare the normal operating pressures to the pressures obtained from the gauges. Check unit components if there are significant differences.
- 3 - Measure the outdoor ambient temperature and the suction pressure. Refer to the charging curve to determine a target liquid temperature.

**Note** - Pressures are listed for sea level applications.

- 4 - Use the same thermometer to accurately measure the liquid temperature (in the outdoor section).
  - If measured liquid temperature is higher than the target liquid temperature, add refrigerant to the system.
  - If measured liquid temperature is lower than the target liquid temperature, recover some refrigerant from the system.
- 5 - Add or remove charge in increments. Allow the system to stabilize each time refrigerant is added or removed.
- 6 - Continue the process until measured liquid temperature agrees with the target liquid temperature. Do not go below the target liquid temperature when adjusting charge. Note that suction pressure can change as charge is adjusted.
- 7 - Example: For an LGT092, at 95°F outdoor ambient and a measured suction pressure of 130psig, the target liquid temperature is 85°F. For a measured liquid temperature of 106°F, add charge in increments until measured liquid temperature agrees with the target liquid temperature.

**TABLE 8 581249-01  
LGT092**

Normal Operating Pressures												
Outdoor Coil Entering Air Temperature												
	65°F		75°F		85°F		95°F		105°F		115°F	
	Suct (psig)	Disc (psig)	Suct (psig)	Disc (psig)	Suct (psig)	Disc (psig)	Suct (psig)	Disc (psig)	Suct (psig)	Disc (psig)	Suct (psig)	Disc (psig)
Circuit 1	95	214	96	252	98	295	100	343	102	397	105	456
	104	216	105	253	107	295	109	343	111	397	114	456
	122	222	123	257	125	299	127	346	130	398	133	456
	140	229	142	264	144	305	146	351	149	402	152	459
Circuit 2	111	221	113	258	114	300	116	347	118	398	120	455
	121	224	122	260	123	302	125	349	128	400	130	456
	140	230	141	266	143	307	145	353	148	404	150	460
	159	238	161	273	163	314	165	359	168	410	171	465

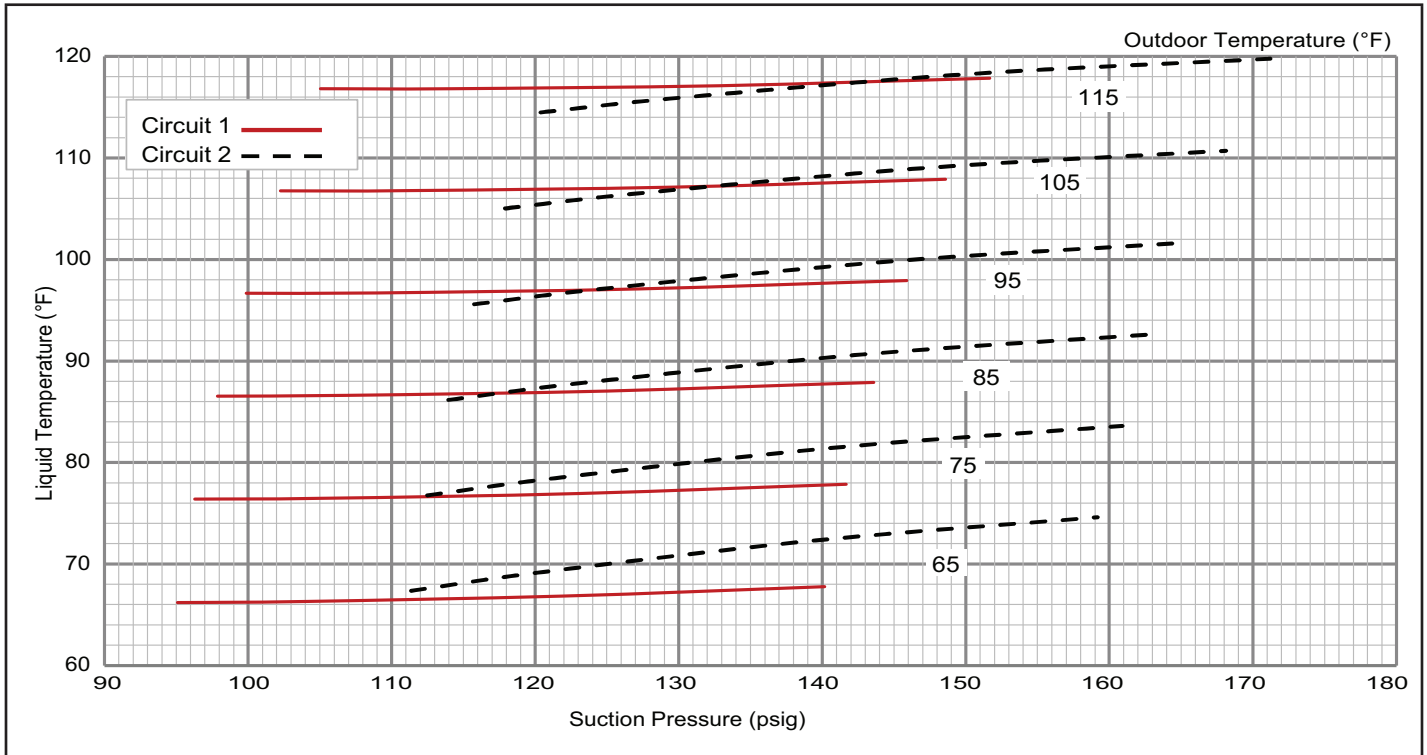

**TABLE 9 581250-01  
LGT092 w/ Reheat**

Normal Operating Pressures												
Outdoor Coil Entering Air Temperature												
	65°F		75°F		85°F		95°F		105°F		115°F	
	Suct (psig)	Disc (psig)	Suct (psig)	Disc (psig)	Suct (psig)	Disc (psig)	Suct (psig)	Disc (psig)	Suct (psig)	Disc (psig)	Suct (psig)	Disc (psig)
Circuit 1	100	224	103	260	105	300	107	345	109	395	110	449
	107	225	110	261	112	301	115	346	117	396	119	450
	122	230	126	266	128	307	131	352	134	402	136	456
	139	241	142	277	146	318	149	363	152	413	155	468
Circuit 2	116	222	118	257	120	297	121	343	123	394	125	450
	125	223	127	258	129	298	130	344	132	395	134	451
	143	228	145	263	147	303	149	349	151	400	153	456
	162	237	165	272	167	312	170	358	172	409	175	465

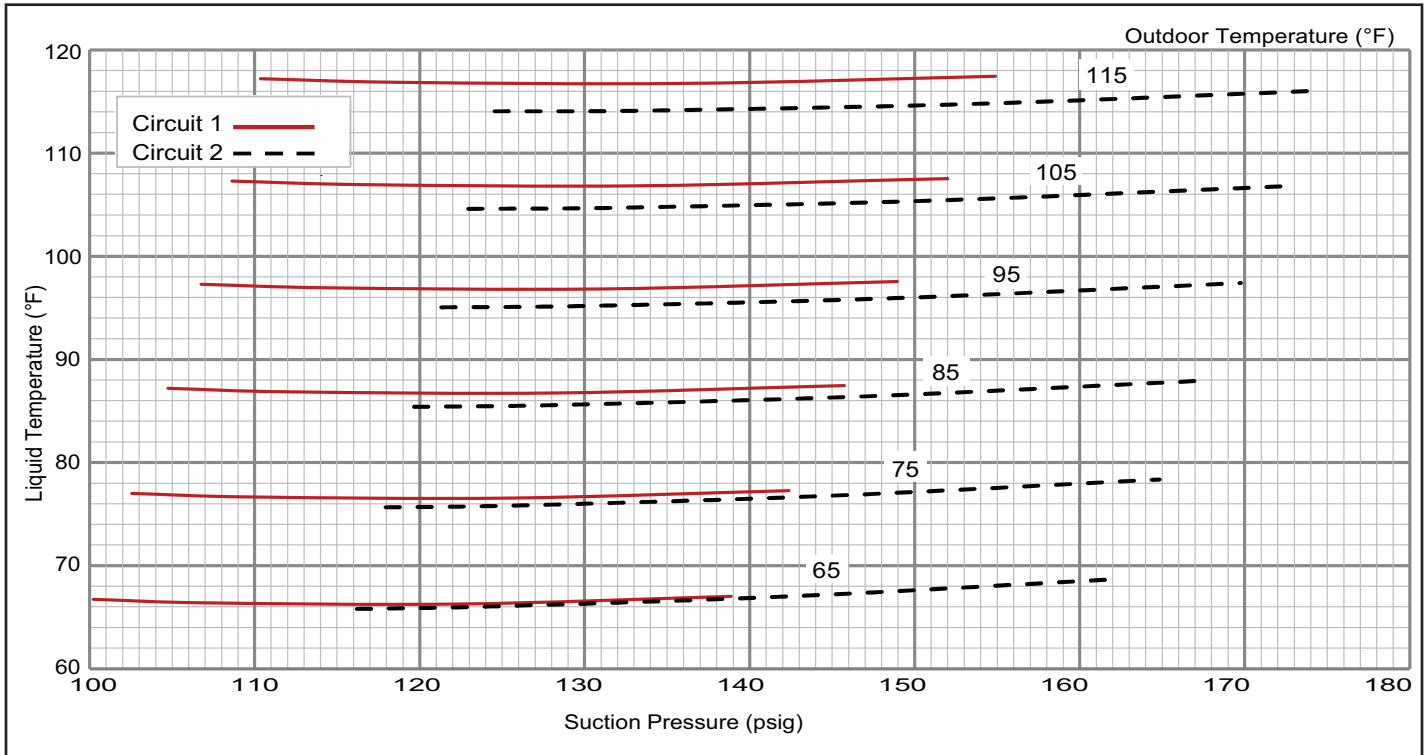

**TABLE 10 581251-01  
LGT102**

Normal Operating Pressures												
Outdoor Coil Entering Air Temperature												
	65°F		75°F		85°F		95°F		105°F		115°F	
	Suct (psig)	Disc (psig)	Suct (psig)	Disc (psig)	Suct (psig)	Disc (psig)	Suct (psig)	Disc (psig)	Suct (psig)	Disc (psig)	Suct (psig)	Disc (psig)
<b>Circuit 1</b>	98	219	100	255	102	297	104	345	107	399	109	459
	106	221	108	257	111	298	113	346	115	399	118	459
	123	228	126	263	128	303	130	350	133	403	135	462
	141	237	144	271	146	311	149	357	151	409	154	467
<b>Circuit 2</b>	112	228	113	264	115	306	117	352	119	404	121	462
	121	231	122	266	124	307	126	354	128	405	130	462
	139	238	141	273	143	313	145	358	147	409	150	465
	159	248	161	282	163	321	166	365	168	415	171	470

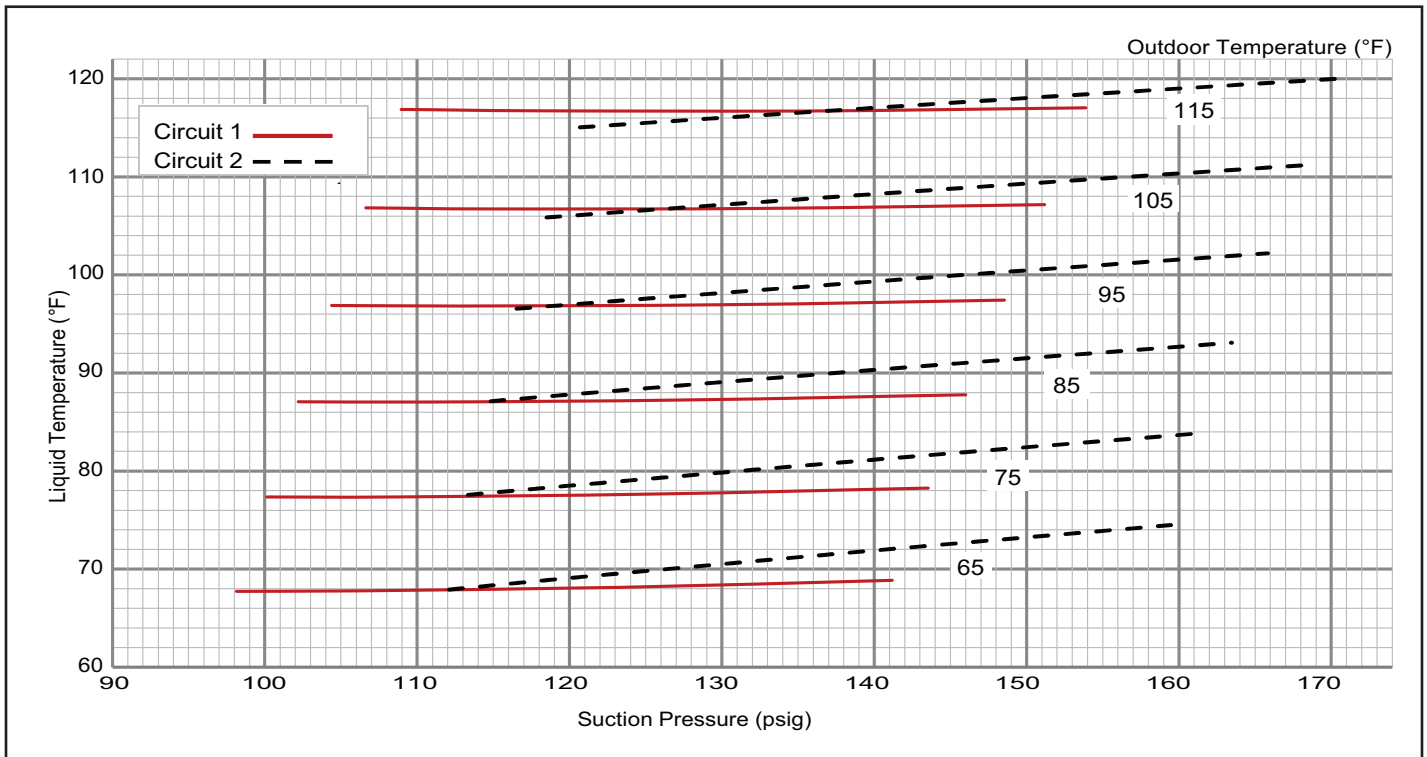

**TABLE 11 581252-01  
LGT102 w/ Reheat**

Normal Operating Pressures												
Outdoor Coil Entering Air Temperature												
	65°F		75°F		85°F		95°F		105°F		115°F	
	Suct (psig)	Disc (psig)	Suct (psig)	Disc (psig)	Suct (psig)	Disc (psig)	Suct (psig)	Disc (psig)	Suct (psig)	Disc (psig)	Suct (psig)	Disc (psig)
Circuit 1	98	228	101	267	104	314	107	370	109	435	112	509
	106	227	109	264	112	310	115	365	117	429	120	501
	122	232	125	266	128	309	131	362	134	423	137	493
	139	245	143	277	146	318	149	368	153	426	156	494
Circuit 2	112	225	115	262	117	306	119	357	121	415	122	479
	120	227	123	263	126	307	128	357	130	414	131	477
	139	234	142	269	145	311	147	360	149	415	150	477
	159	245	162	279	165	319	168	367	170	421	172	482

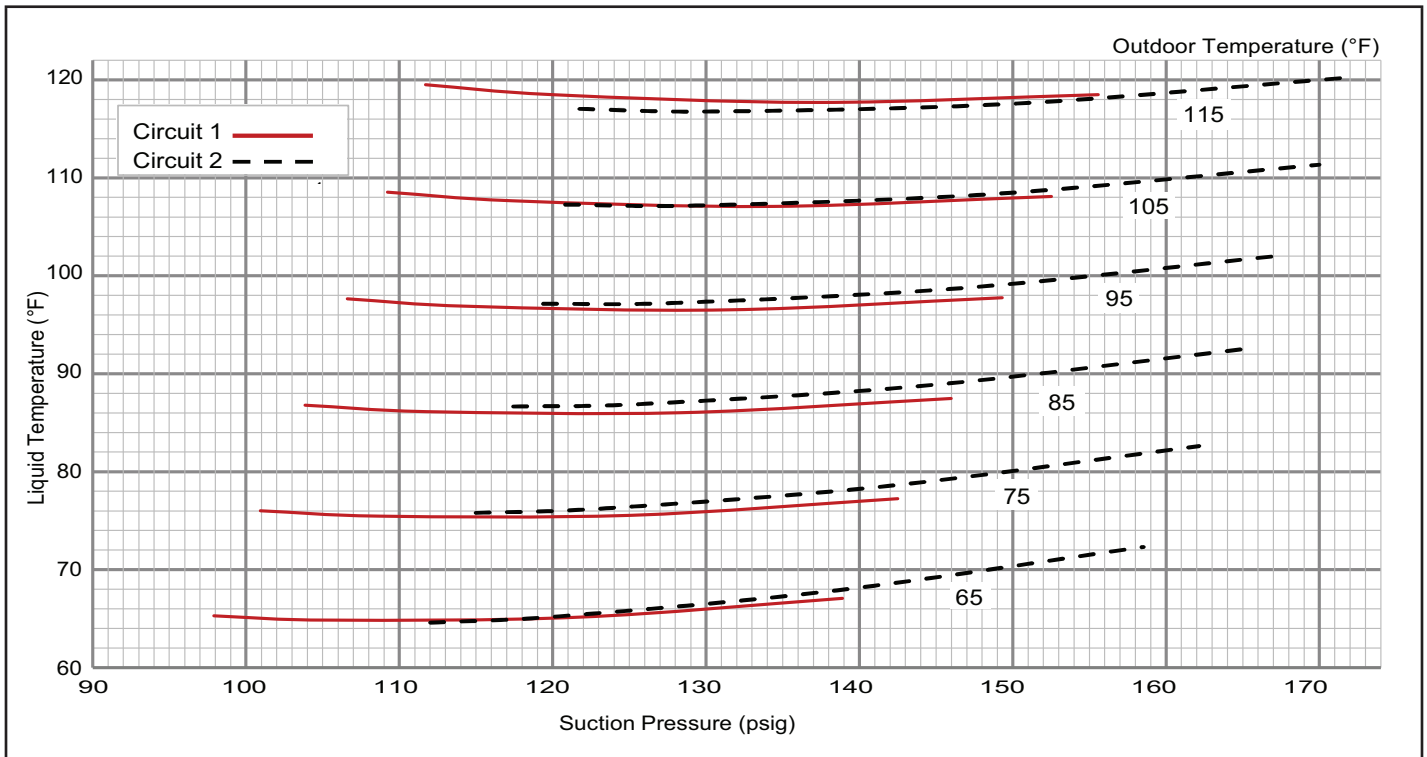

**TABLE 12 581253-01  
LGT120**

Normal Operating Pressures												
Outdoor Coil Entering Air Temperature												
	65°F		75°F		85°F		95°F		105°F		115°F	
	Suct (psig)	Disc (psig)	Suct (psig)	Disc (psig)	Suct (psig)	Disc (psig)	Suct (psig)	Disc (psig)	Suct (psig)	Disc (psig)	Suct (psig)	Disc (psig)
Circuit 1	95	228	97	266	100	310	102	357	105	409	108	466
	104	229	106	268	108	311	111	358	114	411	117	467
	120	235	123	273	126	316	128	363	132	415	135	471
	138	242	141	280	144	323	147	370	150	422	154	478
Circuit 2	112	233	113	273	114	318	114	369	115	425	116	487
	120	237	121	276	122	320	123	370	124	425	125	486
	136	246	138	283	140	326	142	373	144	427	146	486
	155	256	157	292	160	332	163	378	166	430	169	487

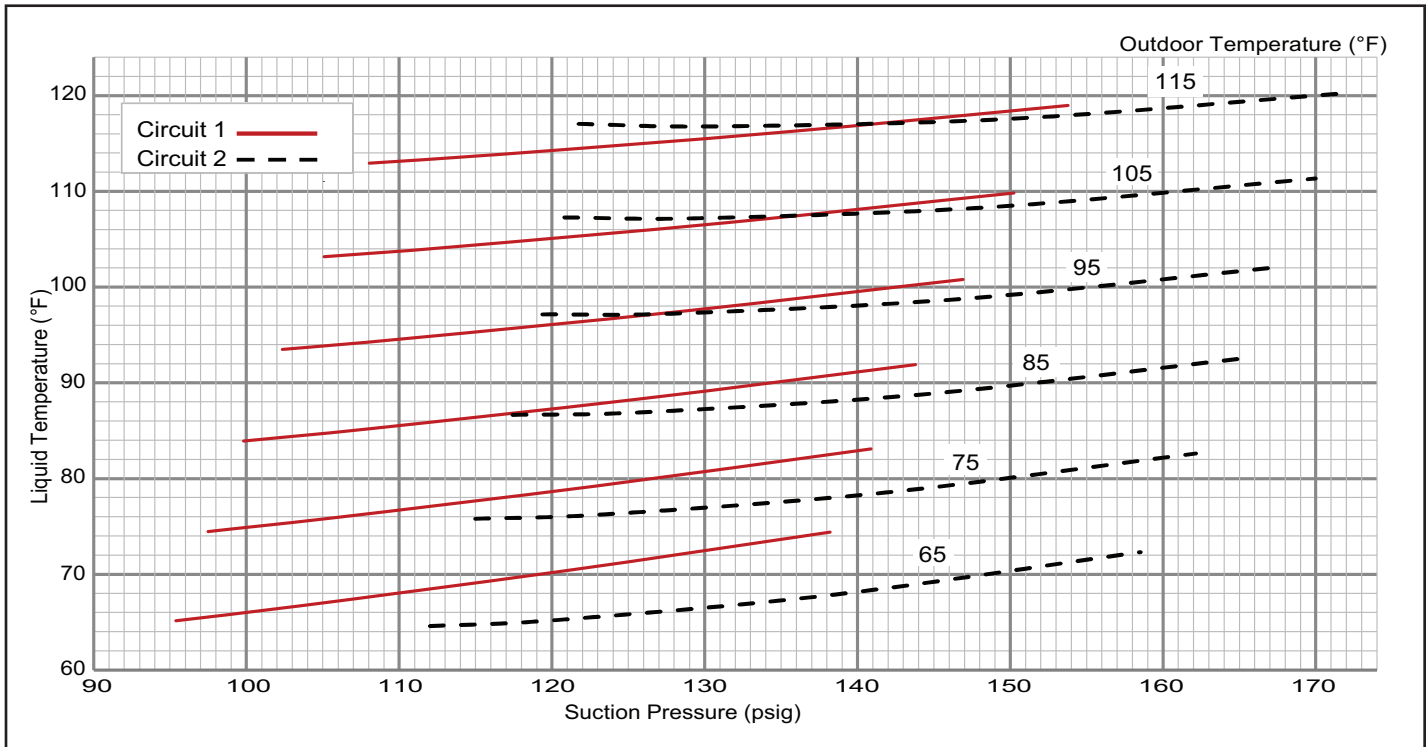

**TABLE 13 581254-01**  
**LGT120 w/ Reheat**

Normal Operating Pressures												
Outdoor Coil Entering Air Temperature												
	65°F		75°F		85°F		95°F		105°F		115°F	
	Suct (psig)	Disc (psig)	Suct (psig)	Disc (psig)	Suct (psig)	Disc (psig)	Suct (psig)	Disc (psig)	Suct (psig)	Disc (psig)	Suct (psig)	Disc (psig)
<b>Circuit 1</b>	97	240	100	278	102	322	105	371	107	427	109	489
	104	241	107	278	109	321	112	370	114	425	117	486
	121	247	124	283	127	325	130	373	132	427	135	487
	142	262	145	297	148	337	152	384	155	437	158	495
<b>Circuit 2</b>	111	240	113	279	116	322	118	370	120	422	122	479
	119	242	121	280	124	323	126	370	128	423	131	480
	137	248	140	286	142	329	145	376	148	428	150	484
	158	260	161	297	165	340	168	387	171	438	174	495

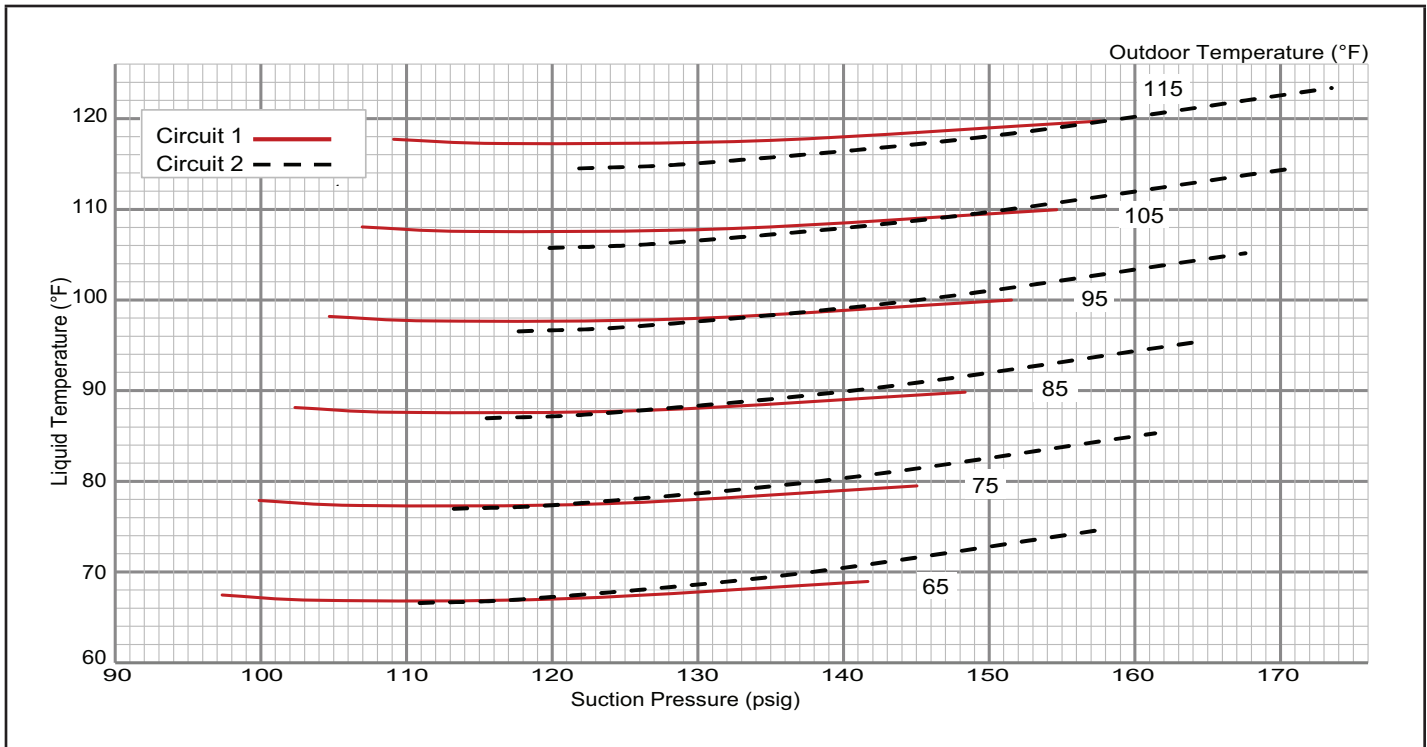

**TABLE 14 581255-01  
LGT150**

Normal Operating Pressures												
Outdoor Coil Entering Air Temperature												
	65°F		75°F		85°F		95°F		105°F		115°F	
	Suct (psig)	Disc (psig)	Suct (psig)	Disc (psig)	Suct (psig)	Disc (psig)	Suct (psig)	Disc (psig)	Suct (psig)	Disc (psig)	Suct (psig)	Disc (psig)
Circuit 1	93	233	95	272	98	316	100	365	102	418	104	476
	101	234	103	273	106	317	108	365	111	418	113	476
	117	241	120	280	123	323	126	370	128	422	131	479
	134	253	138	291	141	333	144	380	147	431	150	488
Circuit 2	107	255	108	297	109	345	110	399	111	459	113	525
	114	258	116	299	117	346	119	399	120	457	122	522
	130	270	132	308	134	352	137	402	139	458	142	520
	147	289	150	324	153	366	156	413	160	466	163	525

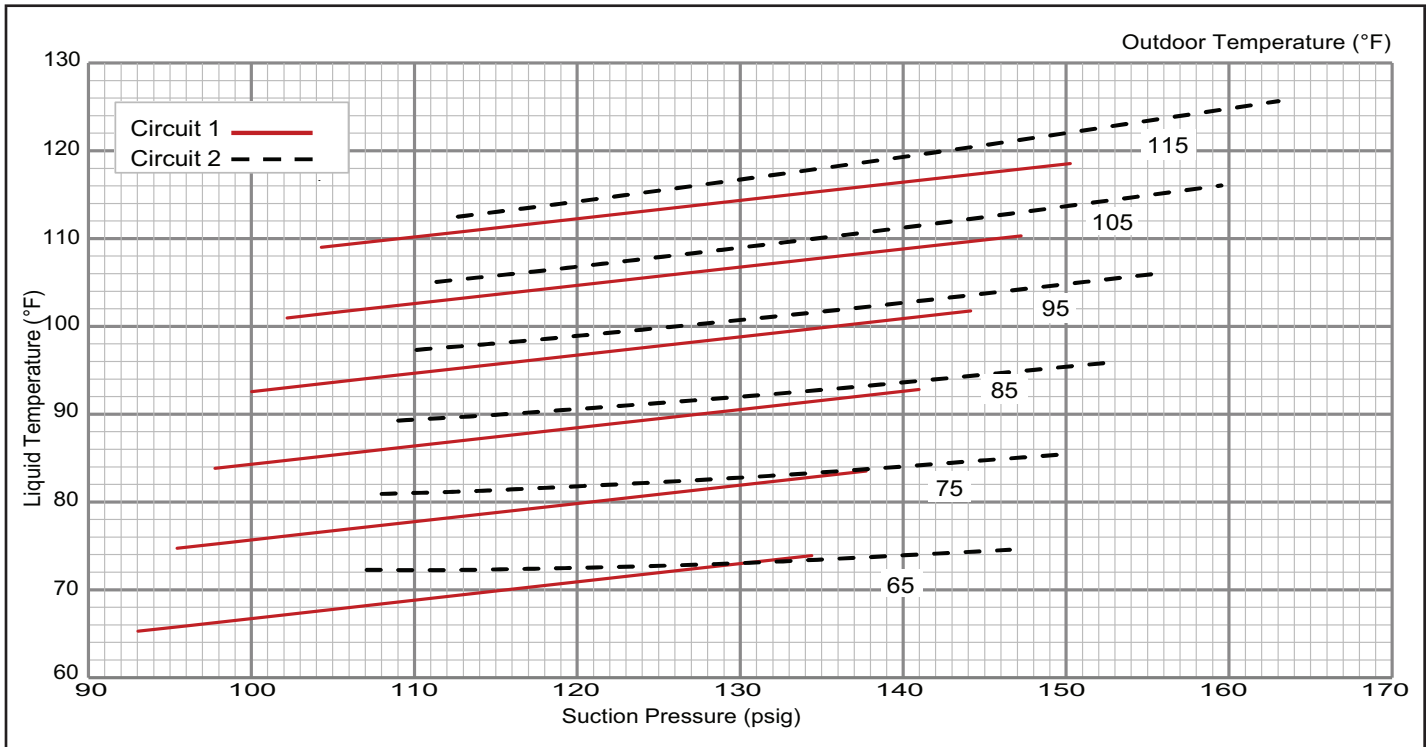

**TABLE 15 581256-01**  
**LGT150 w/ Reheat**

Normal Operating Pressures												
Outdoor Coil Entering Air Temperature												
	65°F		75°F		85°F		95°F		105°F		115°F	
	Suct (psig)	Disc (psig)	Suct (psig)	Disc (psig)	Suct (psig)	Disc (psig)	Suct (psig)	Disc (psig)	Suct (psig)	Disc (psig)	Suct (psig)	Disc (psig)
Circuit 1	94	245	96	281	99	323	104	371	110	426	116	487
	102	249	104	284	107	326	111	374	117	428	123	489
	119	258	120	292	123	333	127	380	132	434	138	494
	137	269	138	303	140	343	143	389	147	442	153	501
Circuit 2	106	253	109	292	112	336	117	386	122	442	129	503
	114	258	116	297	120	340	124	390	130	445	137	507
	129	270	131	307	135	351	139	399	145	454	152	515
	144	283	146	320	150	362	154	410	160	464	167	524

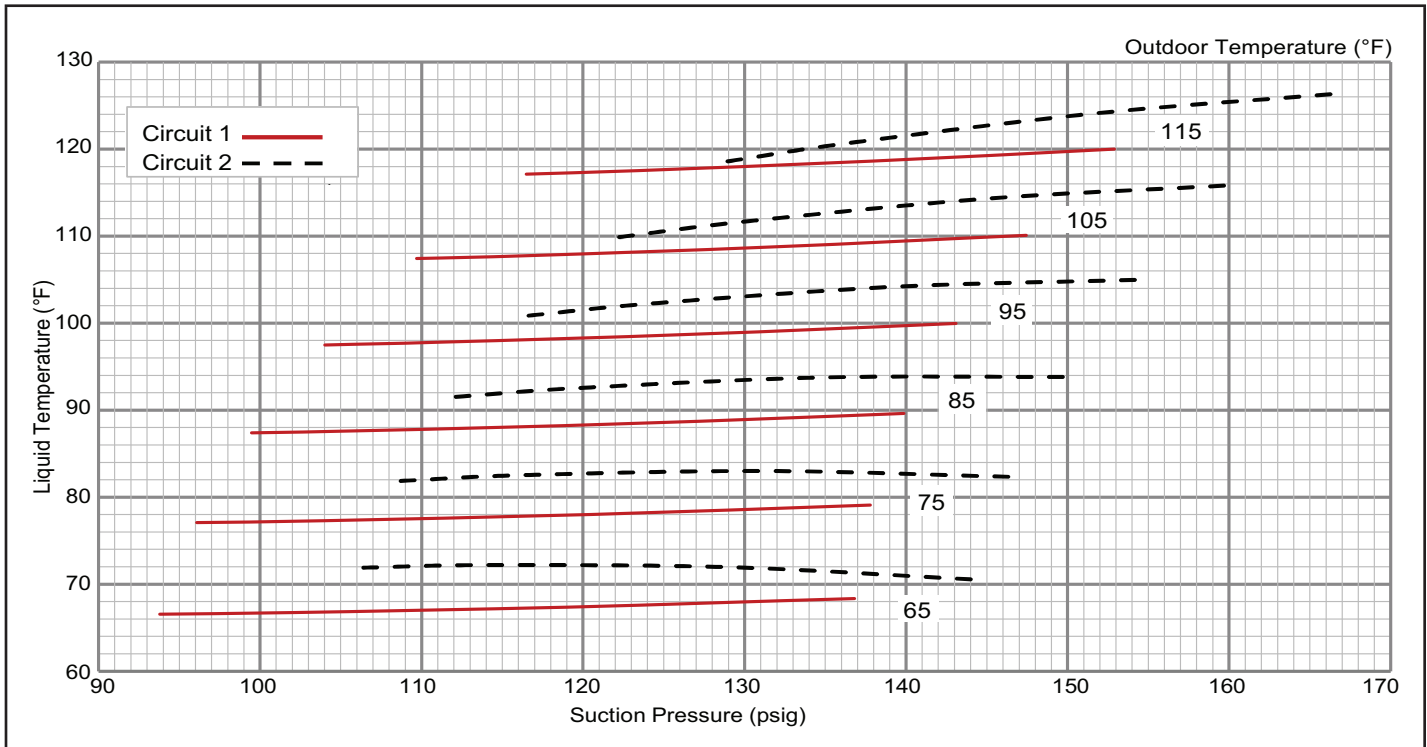

## IV-START-UP - OPERATION

Refer to start-up directions and to the unit wiring diagram when servicing. See unit nameplate for minimum circuit ampacity and maximum fuse size.

### A-Preliminary and Seasonal Checks

- 1 - Make sure the unit is installed in accordance with the installation instructions and applicable codes.
- 2 - Inspect all electrical wiring, both field and factory installed for loose connections. Tighten as required. Refer to unit diagram located on inside of unit control box cover.
- 3 - Check to ensure that refrigerant lines are in good condition and do not rub against the cabinet or other refrigerant lines.
- 4 - Check voltage. Voltage must be within the range listed on the nameplate. If not, consult power company and have the voltage corrected before starting the unit.
- 5 - Recheck voltage and amp draw with unit running. If voltage is not within range listed on unit nameplate, stop unit and consult power company. Refer to unit nameplate for maximum rated load amps.

### B-Cooling Start-up See FIGURE 23

**NOTE**-Crankcase heaters must be energized 24 hours before attempting to start compressor. Set thermostat so that there is no demand to prevent compressor from cycling. Apply power to unit.

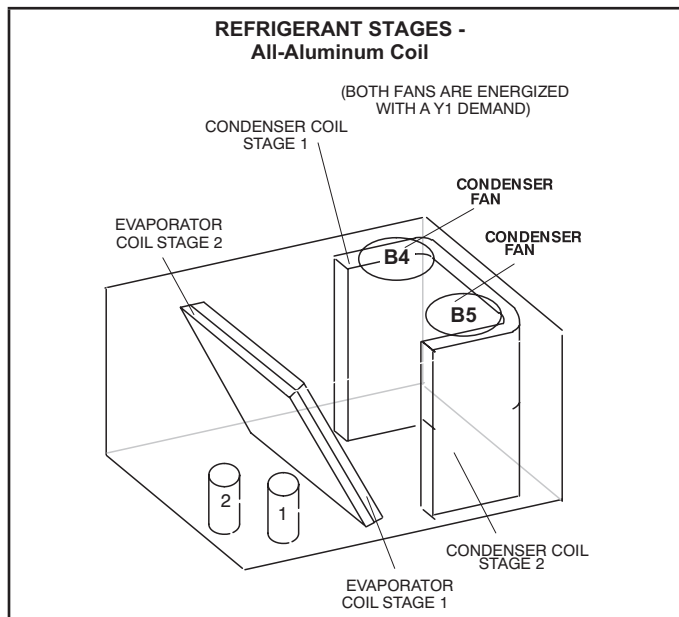

FIGURE 23

- 1 - Initiate first, second or third stage cooling demands according to instructions provided with thermostat or from the mobile service app at the following path:

RTU MENU > SERVICE > COMPONENT TEST >  
COOLING > COOLING STAGE 1/2/3

- 2 - With 2-stage cooling thermostat, the first-stage thermostat demand will energize compressor 1 Full Load. Second-stage thermostat demand will energize compressor 2.

With 3-stage cooling thermostat, the first-stage thermostat demand will energize compressor 1 Part Load. Second-stage thermostat demand will energize compressor 2.

Third-stage thermostat demand will energize compressor 1 Full Load and Compressor 2

- 3 - Units contain two refrigerant circuits or stages.
- 4 - Each refrigerant circuit is separately charged with refrigerant. See unit rating plate for correct amount of charge.

### C-Heating Start-up

#### FOR YOUR SAFETY READ BEFORE LIGHTING

<b>⚠ WARNING</b>	
	<b>Danger of explosion. Can cause injury or product or property damage. If overheating occurs or if gas supply fails to shut off, shut off the manual gas valve to the appliance before shutting off electrical supply.</b>

<b>⚠ WARNING</b>	
	<b>Electric shock hazard. Can cause injury or death. Do not use this unit if any part has been under water. Immediately call a qualified service technician to inspect the unit and to replace any part of the control system and any gas control which has been under water.</b>

BEFORE LIGHTING smell all around the appliance area for gas. Be sure to smell next to the floor because some gas is heavier than air and will settle on the floor.

Use only your hand to push in or turn the gas control knob. Never use tools. If the knob will not push in or turn by hand, do not try to repair it, call a qualified service technician. Force or attempted repair may result in a fire or explosion.

<b>⚠ IMPORTANT</b>	
<b>Units equipped with a Hot Gas Reheat system MUST be charged in standard cooling mode.</b>	

In case of a safety shutdown, move thermostat switch to OFF and return the thermostat switch to HEAT to reset ignition control.

### Placing Furnace In Operation

- 1 - Set thermostat to lowest setting.
- 2 - Turn off all electrical power to appliance.
- 3 - This appliance is equipped with an ignition device which automatically lights the burner. Do not try to light the burner by hand.
- 4 - Open or remove the heat section access panel.
- 5 - Turn gas valve switch to "OFF". Do not force.
- 6 - Wait five (5) minutes to clear out any gas. If you then smell gas, **STOP!** Immediately call your gas supplier from a neighbor's phone. Follow the gas supplier's instructions. If you do not smell gas, go to the next step.
- 7 - Turn gas valve switch to "ON". Do not force.
- 8 - Close or replace the heat section access panel.
- 9 - Turn on all electrical power to appliance.
- 10 - Set thermostat to desired setting.
- 11 - The combustion air inducer will start. The burners will light within 40 seconds.
- 12 - If the appliance does not light the first time (gas line not fully purged), it will attempt two more ignitions before locking out.
- 13 - If lockout occurs, repeat steps 1 through 10.
- 14 - If the appliance will not operate, follow the instructions "Turning Off Gas to Appliance" and call your service technician or gas supplier.

### Turning Off Gas to Appliance

- 1 - If using an electromechanical thermostat, set to the lowest setting.
- 2 - Before performing any service, turn off all electrical power to the appliance.
- 3 - Open or remove the heat section access panel.
- 4 - Turn gas valve switch to "OFF". Do not force.

### D-Safety or Emergency Shutdown

Turn off power to the unit. Close manual and main gas valves.

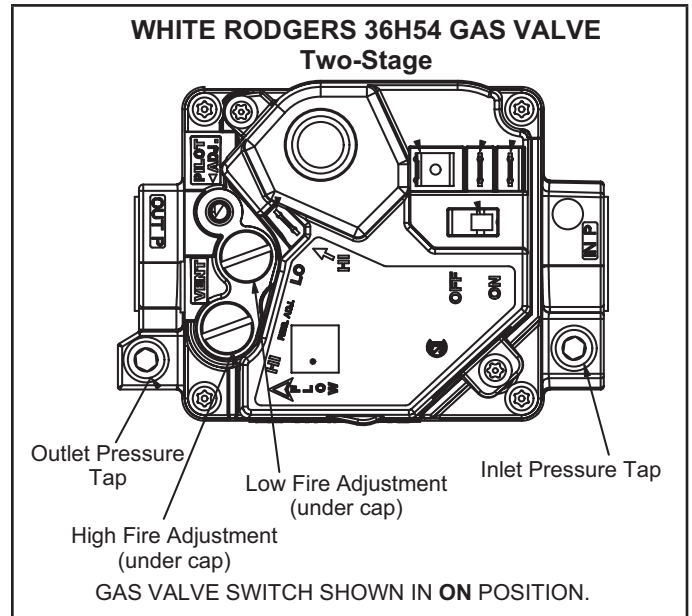

**FIGURE 24**

## V- SYSTEMS SERVICE CHECKS

### A-Heating System Service Checks

All LGT units are ETL/CSA design certified without modification.

Before checking piping, check with gas company or authorities having jurisdiction for local code requirements. Refer to the LGT installation instruction for more information.

#### 1-Gas Piping

Gas supply piping must not allow more than 0.5"W.C. (124.3 Pa) drop in pressure between the gas meter and the unit. Supply gas pipe must not be smaller than the unit gas connection. Refer to installation instructions for details.

#### 2-Testing Gas Piping

**NOTE**-In case emergency shutdown is required, turn off the main manual shut-off valve and disconnect the main power to the unit. These controls should be properly labeled by the installer.

When pressure testing gas lines, the gas valve must be disconnected and isolated. **Gas valves can be damaged if subjected to more than 0.5 psig [14"W.C. (3481 Pa)].** See FIGURE 25.

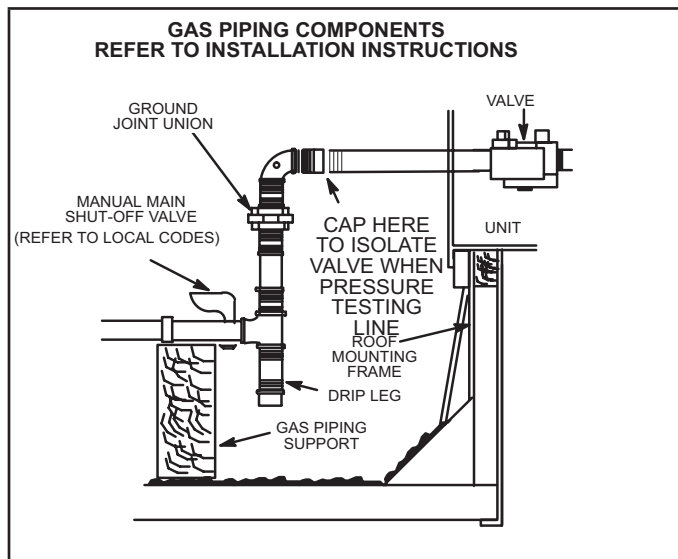

FIGURE 25

When checking piping connection for gas leaks, use the preferred means. Common kitchen detergents can cause harmful corrosion on various metals used in gas piping.

The use of specialty Gas Leak Detector is strongly recommended.

**Do not use matches, candles, flame or any other source of ignition to check for gas leaks.**

#### 3-Testing Gas Supply Pressure

When testing gas supply pressure, connect test gauge to the inlet pressure tap located on unit gas valve GV1. Test supply gas pressure with unit firing at maximum rate (both stages energized). Make sure the reading falls within the range of the following values.

Low pressure may result in erratic operation or "underfire." High pressure can result in permanent damage to the gas valve or "overfire."

For natural gas units, operating pressure at the unit gas connection must be between 4.7"W.C. and 10.5"W.C. (1168 Pa and 2610 Pa). For L.P. gas units, operating pressure at the unit gas connection must be between 10.8"W.C. and 13.5"W.C. (2685.3 Pa and 3356.7 Pa).

On multiple unit installations, each unit should be checked separately while operating at maximum rate, beginning with the one closest to the supply gas main and progressing to the one furthest from the main. Multiple units should also be tested with and without the other units operating. Supply pressure must fall within the range listed in the previous paragraph.

#### 4-Check and Adjust Manifold Pressure

After line pressure has been checked and adjusted, check manifold pressure. Move test gauge to the outlet pressure tap located on unit gas valve GV1 and or GV3. See figure 24 for location of pressure tap on the gas valve.

The manifold pressure is factory set and should not require adjustment. If manifold pressure is incorrect and no other source of improper manifold pressure can be found, the valve must be replaced. See FIGURE 24 for location of gas valve (manifold pressure) adjustment screw.

All gas valves are factory regulated. The gas valve should completely and immediately cycle off in the event of gas or power failure. The manual shut-off knob can be used to immediately shut off gas supply.

### CAUTION

For safety, connect a shut-off valve between the manometer and the gas tap to permit shut off of gas pressure to the manometer.

#### Manifold Adjustment Procedure

- 1 - Connect test gauge to the outlet pressure tap on the gas valve. Start the unit (call for second stage heat) and allow five minutes for the unit to reach steady state.
- 2 - While waiting for the unit to stabilize, notice the flame. The flame should be stable without flashback and should not lift from the burner heads. Natural gas should burn basically blue with some clear streaks. L.P. gas should burn mostly blue with some clear yellow streaks.
- 3 - After allowing the unit to stabilize for five minutes, record the manifold pressure and compare to the values given in TABLE 7.

### CAUTION

Disconnect heating demand as soon as an accurate reading has been obtained.

## 5-Proper Gas Flow

To check for proper gas flow to burners, determine Btuh input from unit rating plate or the gas heating capacity in the SPECIFICATIONS tables. Divide this input rating by the Btuh per cubic foot of available gas. Result is the number of cubic feet per hour required. Determine the flow of gas through gas meter for two minutes and multiply by 30 to get hourly flow of gas to the burners.

**NOTE** - To obtain accurate reading, shut off all other gas appliances connected to meter.

## 6-Inshot Burner

Burners are factory set for maximum air and cannot be adjusted. Always operate unit with access panel in place. A peep hole is furnished in the heating access panel for flame viewing. Natural gas should burn basically blue with some clear streaks. L.P. gas should burn mostly blue with some clear yellow streaks.

Follow steps below to remove burner assembly.

- 1 - Turn off power to unit and shut off gas supply.
- 2 - Remove screws holding the burner support cap.
- 3 - Burner assembly is a cluster assembly (figure 31) and can be removed as one.
- 4 - Clean and reassemble (reverse steps 1-3).
- 5 - Be sure to secure all wires and check plumbing.
- 6 - Turn on power to unit. Follow lighting instructions attached to unit and operate unit in heating mode. Check burner flames. They should be blue with yellow streaks.

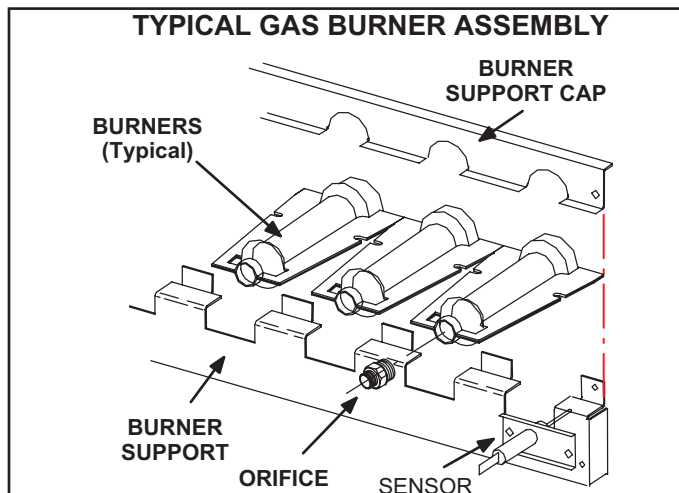

FIGURE 26

## 7-Spark Electrode Gap

The spark electrode assembly can be removed for inspection by removing two screws securing the electrode assembly and sliding it out of unit.

For proper unit operation, electrodes must be positioned and the spark gap set correctly. Spark gap may be checked with appropriately sized twist drills or feeler gauges.

Disconnect power to the unit and remove electrode assembly. The gap should be between 0.125" + 0.015" (3.2 mm + .4 mm). See FIGURE 21.

## 8-Heat Exchanger

To Access or Remove Heat Exchanger From Unit:

- 1 - Turn off gas and electric power.
- 2 - Remove access panel(s) and unit center mullion.
- 3 - Remove gas valve, manifold assembly and burners.
- 4 - Remove combustion air inducer and flue box. Pay careful attention to the order in which gaskets and orifice are removed.
- 5 - Support heat exchanger (to prevent it from falling when final screws are removed.)
- 6 - Remove screws supporting heat exchanger.
- 7 - To install heat exchanger, reverse procedure. Be sure to secure all wires and check plumbing and burner plate for airtight seal. Screws must be torqued to 35 in.- lbs. to ensure proper operation.

## 9-Flame Sensing

Flame current is an electrical current which passes from the ignition control through the sensor electrode during unit operation.

The current passes from the sensor through the flame to the ground electrode (located on the flame electrode) to complete a safety circuit. The electrodes should be located so the tips are at least 1/2" (12.7 mm) inside the flame envelope. Do not bend electrodes. To measure flame current, follow the procedure on the following page:

**NOTE**-Electrodes are not field adjustable. Any alterations to the electrode may create a hazardous condition that can cause property or personal injury.

- 1 - Disconnect power to unit.
- 2 - Remove lead from sensing electrode and install a 0-50DC microamp meter in series between the sensing electrode and the sensing lead.
- 3 - Reconnect power and adjust thermostat for heating demand.
- 4 - When flame is established, compare reading to TABLE 16. Do not bend electrodes.
- 5 - Disconnect power to unit before disconnecting meter. Make sure sensor wire is securely reconnected before reconnecting power to unit.

TABLE 16

Manufacturer	Nominal Signal Microamps	Drop Out
Johnson	0.5 - 1.0	.09

**NOTE**-If the meter scale reads 0, the leads are reversed. Disconnect power and reconnect leads for proper polarity.

## 10-Combustion Air Inducer

The combustion air inducer is factory set and is not field adjustable. However, operation should be monitored to ensure proper operation. The combustion air inducer is used to draw fresh air into the combustion chamber while simultaneously expelling exhaust gases. The inducer operates throughout the heating cycle.

On a heating demand, the ignition control is energized by the A55 Unit Controller. The ignition control then allows 30 to 40 seconds for the combustion air inducer to vent exhaust gases from the burners. When the combustion air inducer is purging the exhaust gases, the combustion air prove switch is closing proving that the combustion air inducer is operating before allowing the ignition control to energize.

When the combustion air prove switch is closed and the delay is over, the ignition control activates the first stage operator of the gas valve (low fire), the spark and the flame sensing electrode. Sparking stops immediately after flame is sensed.

### B-Cooling System Service Checks

LGT units are factory charged and require no further adjustment; however, charge should be checked periodically. See section III- CHARGING.

### VI-MAINTENANCE

The unit should be inspected once a year by a qualified service technician.

<b>⚠ WARNING</b>	
	Electric shock hazard. Can cause injury or death. Before attempting to perform any service or maintenance, turn the electrical power to unit OFF at disconnect switch(es). Unit may have multiple power supplies.

<b>⚠ IMPORTANT</b>	
Label all wires prior to disconnection when servicing controls. Wiring errors can cause improper and dangerous operation. Verify proper operation after servicing.	

<b>⚠ WARNING</b>	
Any service personnel installing, decommissioning, or performing maintenance on the unit must be properly trained with A2L refrigerants	

### Prior to beginning work on systems containing refrigerant to ensure the risk of ignition is minimized:

- All work shall be undertaken under a controlled procedure so as to minimize the risk of a flammable gas or vapor being present while the work is being performed.

- The area shall be checked with an appropriate refrigerant detector prior to and during work, to ensure the technician is aware of potentially toxic or flammable atmospheres. Ensure that the leak detection equipment being used is suitable for use with all applicable refrigerants, i. e. non-sparking, adequately sealed or intrinsically safe.
- If any hot work is to be conducted on the refrigerating equipment or any associated parts, the appropriate fire extinguishing equipment shall be available to hand. Have a dry powder or CO2 fire extinguisher adjacent to the charging area.
- No person carrying out work in relation to a refrigerating system which involves exposing any pipe work shall use any sources of ignition in such a manner that it may lead to the risk of fire or explosion. All possible ignition sources, including cigarette smoking, should be kept sufficiently far away from the site of installation, repairing, removing and disposal, during which refrigerant can possibly be released to the surrounding space. Prior to work taking place, the area around the equipment is to be surveyed to make sure that there are no flammable hazards or ignition risks. "No Smoking" signs shall be displayed.
- Ensure that the area is in the open or that it is adequately ventilated before breaking into the system or conducting any hot work.

A degree of ventilation shall continue during the period that the work is carried out. The ventilation should safely disperse any released refrigerant and preferably expel it externally into the atmosphere.

- Where electrical components are being changed, service technicians shall be fit for the purpose and to the correct specification. At all times the manufacturer's maintenance and service guidelines shall be followed. If in doubt, consult the manufacturer's technical department for assistance. The following checks shall be applied to installations using flammable refrigerants as applicable:
  - 1 - The actual refrigerant charge is in accordance with the room size within which the refrigerant containing parts are installed.
  - 2 - The ventilation machinery and outlets are operating adequately and are not obstructed.
  - 3 - If an indirect refrigerating circuit is being used, the secondary circuit shall be checked for the presence of refrigerant.
  - 4 - Markings on the equipment should be visible and legible. Markings and signs that are illegible shall be corrected.

5 - Refrigerating pipes or components are installed in a position where they are unlikely to be exposed to any substance which may corrode refrigerant containing components, unless the components are constructed of materials which are inherently resistant to being corroded or are suitably protected against being so corroded. For systems containing refrigerant all repair and maintenance to electrical components shall include initial safety checks and component inspection procedures such as that capacitors are discharged in a safe manner to avoid possibility of sparking, that no live electrical components and wiring are exposed while charging, recovering, or purging the system, and that there is continuity of earth bonding. If a fault exists that could compromise safety, then no electrical supply shall be connected to the circuit until it is satisfactorily dealt with. If the fault cannot be corrected immediately but it is necessary to continue operation, an adequate temporary solution shall be used that is reported to the owner of the equipment, so all parties are advised.

**NOTE** - Sealed electrical components shall be replaced, not repaired.

**NOTE** - Intrinsically safe components must be replaced, not repaired.

- Under no circumstances shall potential sources of ignition be used in the searching for or detection of refrigerant leaks. A halide torch (or any other detector using a naked flame) shall not be used. Electronic leak detectors may be used to detect refrigerant leaks but, in the case of flammable refrigerants, the sensitivity may not be adequate, or may need re-calibration. (Detection equipment shall be calibrated in a refrigerant-free area.) Ensure that the detector is not a potential source of ignition and is suitable for the refrigerant used. Leak detection equipment shall be set at a percentage of the LFL of the refrigerant and shall be calibrated to the refrigerant employed, and the appropriate percentage of gas (25 % maximum) is confirmed. Leak detection fluids are also suitable for use with most refrigerants but the use of detergents containing chlorine shall be avoided as the chlorine may react with the refrigerant and corrode the copper pipe-work. If a leak is suspected, all naked flames shall be removed/extinguished. If a leakage of refrigerant is found which requires brazing, all of the refrigerant shall be recovered from the system, or isolated (by means of shut off valves) in a part of the system remote from the leak.
- When breaking into the refrigerant circuit to make repairs – or for any other purpose – conventional procedures shall be used. However, for flammable refrigerants it is important that best practice be followed, since flammability is a consideration. The following procedure shall be adhered to:

- a. Safely remove refrigerant following local and national regulations,
- b. Evacuate the circuit,
- c. Purge the circuit with inert gas,
- d. Evacuate,
- e. Purge with inert gas,
- f. Open the circuit.

- The refrigerant charge shall be recovered into the correct recovery cylinders if venting is not allowed by local and national codes. For appliances containing flammable refrigerants, the system shall be purged with oxygen-free nitrogen to render the appliance safe for flammable refrigerants. This process might need to be repeated several times. Compressed air or oxygen shall not be used for purging refrigerant systems. Refrigerant purging shall be achieved by breaking the vacuum in the system with oxygen-free nitrogen and continuing to fill until the working pressure is achieved, then venting to atmosphere, and finally pulling down to a vacuum. This process shall be repeated until no refrigerant is within the system. When the final oxygen-free nitrogen charge is used, the system shall be vented down to atmospheric pressure to enable work to take place. Ensure that the outlet for the vacuum pump is not close to any potential ignition sources and that ventilation is available.

#### **A-Filters**

LGT units use four 20 x 25 x 2" pleated throw-away type filters. Filters may be accessed through the economizer / filter access door. Filters should be checked monthly (or more frequently in severe use) and cleaned or replaced regularly. Take note of the "AIR FLOW DIRECTION" marking on the filter frame when re-installing.

**NOTE**-Filters must be U.L.C. certified or equivalent for use in Canada.

#### **B-Lubrication**

All motors and blower wheels used in LGT units are pre-lubricated; no further lubrication is required.

#### **C-Supply Air Blower Wheel**

Annually inspect supply air blower wheel for accumulated dirt or dust. Turn off power before attempting to remove access panel or to clean blower wheel.

#### **D-Evaporator Coil**

Inspect and clean coil at beginning of each season. Clean using mild detergent or commercial coil cleanser. Check condensate drain pan and line, if necessary. Flush coil and condensate drain with water taking care not to get insulation, filters and return air ducts wet. Check connecting lines and coil for evidence of oil and refrigerant leaks.

## E-Condenser Coil

### *Formed Coils -*

Clean condenser coil annually with water and inspect monthly during the cooling season. Clean the all-aluminum coil by spraying the coil steadily and uniformly from top to bottom. Do not exceed 900 psi or a 45 angle; nozzle must be at least 12 inches from the coil face. Take care not to fracture the braze between the fins and refrigerant tubes. Reduce pressure and work cautiously to prevent damage.

Check connecting lines and coil for evidence of oil and refrigerant leaks.

**NOTE-***If owner complains of insufficient cooling, the unit should be gauged and refrigerant charge checked. Refer to Gauge Manifold Attachment and Charging sections in this manual.*

## F-Electrical

- 1 - Check all wiring for loose connections.
- 2 - Check for correct voltage at unit (unit operating).
- 3 - Check amp-draw on both condenser fan motor and blower motor.

Fan Motor Rating Plate \_\_\_\_ Actual \_\_\_\_\_

Indoor Blower Motor Rating Plate \_\_\_\_ Actual \_\_\_\_

- 4 - Check crankcase heater temperatures to ensure they are operating.
- 5 - Check compressor sump thermistors to ensure they are making contact with compressor shell (ultra high efficiency units only).

## VII-ACCESSORIES

The accessories section describes the application of most of the optional accessories which can be factory or field installed to the LGT units.

### A-Mounting Frames

When installing units on a combustible surface for down-flow discharge applications, a C1CURB roof mounting frame is used. The roof mounting frames are recommended in all other applications but not required. If the LGT units are not mounted on a flat (roof) surface, they MUST be supported under all edges and under the middle of the unit to prevent sagging. The units MUST be mounted level within 1/16" per linear foot or 5mm per meter in any direction.

The assembled C1CURB mounting frame is shown in FIGURE 27. Refer to the roof mounting frame installation instructions for details of proper assembly and mounting. The roof mounting frame MUST be squared to the roof and level before mounting. Plenum system MUST be installed before the unit is set on the mounting frame. Typical roof curbing and flashing is shown in FIGURE 28. Refer to the roof mounting frame installation instructions for proper plenum construction and attachment.



FIGURE 27

### B-LP / Propane Kit

Natural to LP /propane kit includes a spring kit and three stickers. In addition, the LP kit contains either six, nine, or eleven burner orifices. For more detail refer to the natural to LP gas changeover kit installation instructions.

### C-Dirty Filter Switch S27

The dirty filter switch senses static pressure increase indicating a dirty filter condition. The switch is N.O. and closes at 1" W.C. (248.6 Pa) The switch is mounted on the top filter channel corner. Wiring for the dirty filter switch is shown on the temperature control section (C2) wiring diagram in back of this manual.

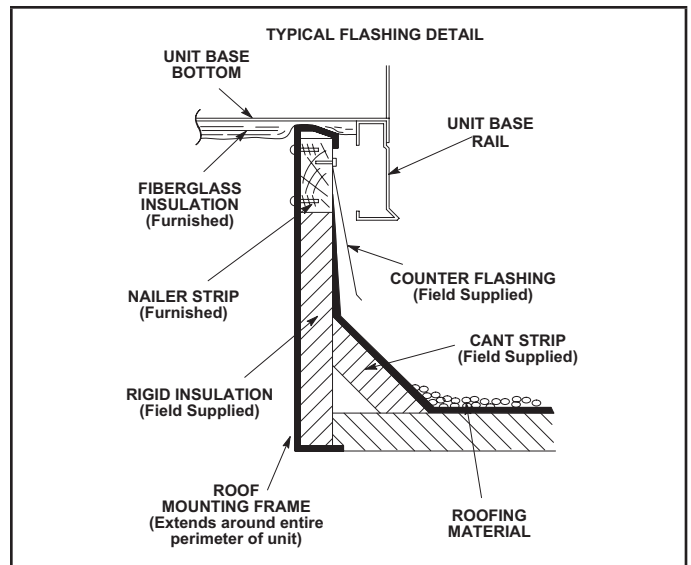

FIGURE 28

### D-Transitions

Optional supply/return transitions LASRT08/10 is available for use with the LGT 7.5 ton units and LASRT10/12 is available for the 8.5 and 10 ton units, utilizing optional C1CURB roof mounting frames. LGT 12.5 ton units will use LASRT15 with C1CURB roof mounting frame. Transition must be installed in the C1CURB mounting frame before mounting the unit to the frame. Refer to the manufacturer's instructions included with the transition for detailed installation procedures.

### E-LAOAD(M) Outdoor Air Dampers (all units)

LAOAD(M) consists of a set of dampers which may be manually or motor (M) operated to allow up to 25 percent outside air into the system at all times (see FIGURE 29 or FIGURE 30). Either air damper can be installed in LGT units. Washable filter supplied with the outdoor air dampers can be cleaned with water and a mild detergent. It should be sprayed with Filter Handicoater when dry prior to re-installation.

### F-Supply and Return Diffusers (all units)

Optional flush mount diffuser/return FD11 and extended mount diffuser/return RTD11 are available for use with all LGT units. Refer to manufacturer's instructions included with transition for detailed installation procedures.

### G-Blower Proving Switch S52

The blower proving switch monitors blower operation and locks out the unit in case of blower failure. The switch is N.O. and closes at .14" W.C. (34.9 Pa) The switch is mounted on the upper left hand corner of the blower deck. Wiring for the blower proving switch is shown on the temperature control section (C2) wiring diagram in back of this manual.

**LAOAD(M) MOTORIZED OUTDOOR AIR DAMPER**

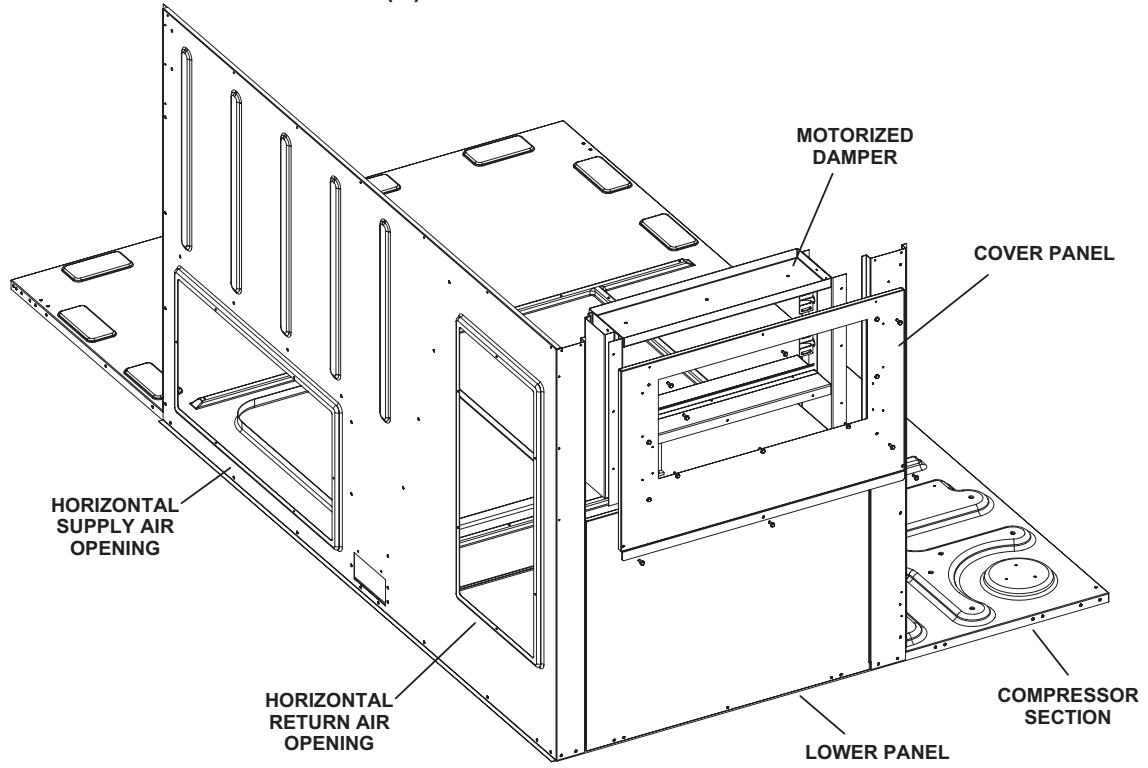

**FIGURE 29**

**MANUAL OUTDOOR AIR DAMPER**

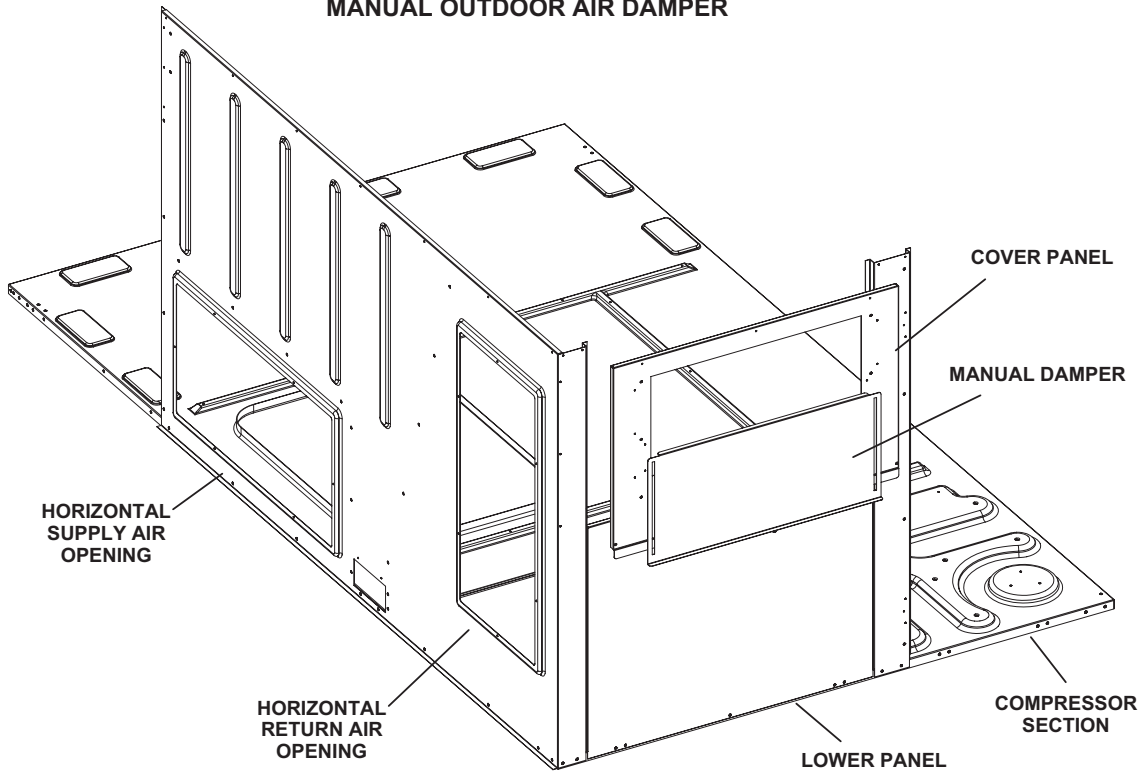

**FIGURE 30**

## H-Economizer (all units) (Field or Factory Installed)

The optional E1ECON15 economizer can be used with downflow and horizontal air discharge applications. See FIGURE 33. The economizer uses outdoor air for free cooling when outdoor temperature and/or humidity is suitable. The economizer is controlled by the A55 Unit Controller.

### Free Cooling Mode

The Unit Controller will allow free cooling in one of five modes. Each mode uses different combinations of sensors to determine outdoor air suitability. See TABLE 17 for modes. Temperature offset is the default free cooling mode.

**NOTE** - All free cooling modes of operation will modulate dampers to 55F (13C) supply / discharge air.

### Unit Controller Settings

On early versions, switches are located on the Unit Controller to adjust settings. On newer versions, the display and keypad on the Unit Controller are used to navigate through menus to adjust settings. Some versions require a configuration ID be entered to enable the economizer. Refer to economizer installation instructions and Unit Controller installation and application manuals.

### I-Gravity Exhaust Dampers

LAGEDH03/15 dampers (FIGURE 31) are used in downflow

and horizontal air discharge applications. Horizontal gravity exhaust dampers are installed in the return air plenum .

The dampers must be used any time an economizer or power exhaust fans are applied to LGT units.

Gravity exhaust dampers allow exhaust air to be discharged from the system when an economizer and/or power exhaust is operating. Gravity exhaust dampers also prevent outdoor air infiltration during unit off cycle. See installation instructions for more detail.

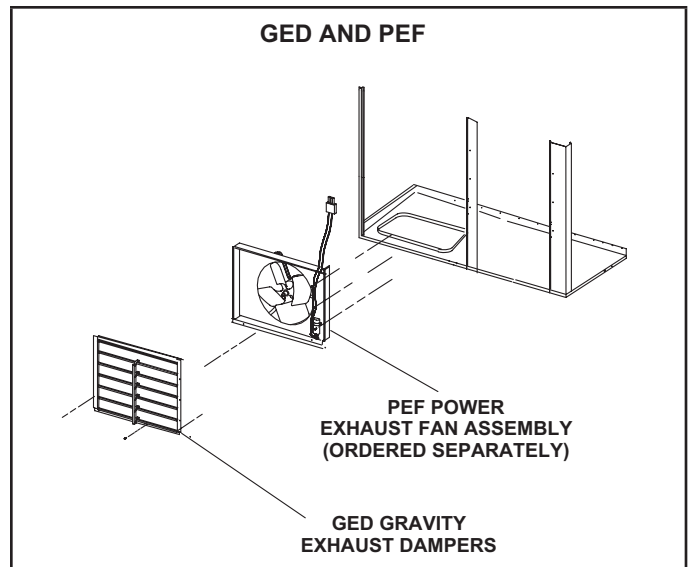

FIGURE 31

### J-LAPEF Power Exhaust Fans

Power exhaust fans are used in downflow applications only. Fan requires optional down flow gravity exhaust dampers and LAREMD economizer. Power exhaust fans provide exhaust air pressure relief and also run when return air dampers are closed and supply air blowers are operating. FIGURE 32 shows the location of the LAPEF. See installation instructions for more detail.

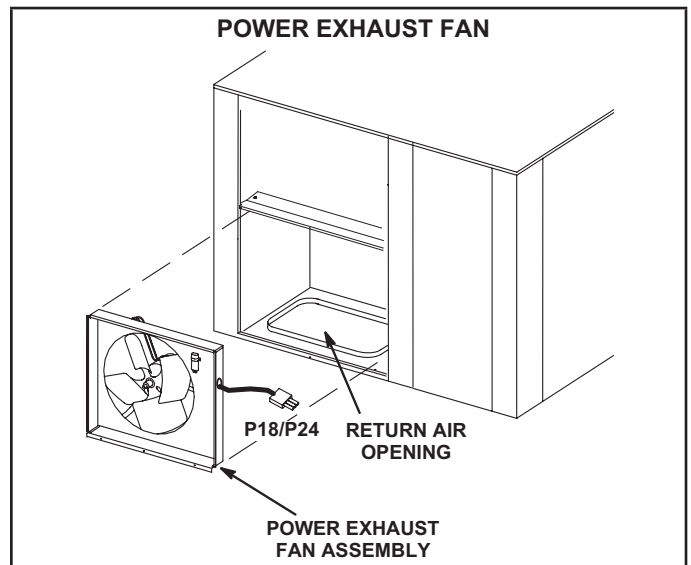

FIGURE 32

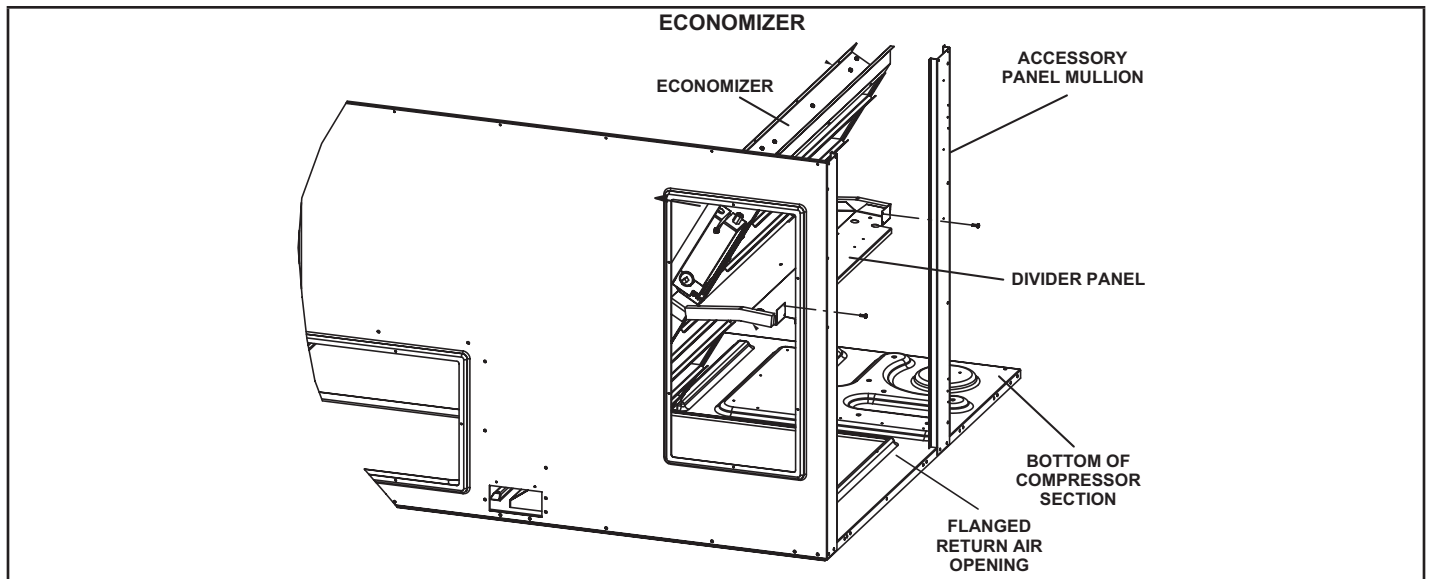

FIGURE 33

TABLE 17  
ECONOMIZER MODES AND SETPOINT

Free Cooling Mode	Free Cooling Set Point	Field Provided Sensors	Dampers will modulate to 55°F (default, parameter 159) discharge air (RT6) when outdoor air is suitable:	Input Ranges
TEMP	OFFSET	None Needed	Outdoor air temperature (RT17) is less than return air temperature (RT16) by at least the OFFSET value (10°F default; parameter 161).	0-40°F
TEMP	OAT STPT	None Needed	Outdoor air temperature (RT17) is less than the OAT STPT value (75°F default; parameter 160).	41-75°F
Remote	Remote	Energy Management System**	Either of the TEMP modes can be used when a network OAS signal is provided by an energy management or building control system, via BACnet, LonTalk, or L Connection. The network can command OAS, NOT OAS, or AUTO. AUTO returns to local control of OAS, which is the selected TEMP mode.	NA
ENTH	DIFF OFFSET	(Two) C7400	Outdoor air enthalpy* (A7) is less than return air enthalpy (A62) by at least the OFFSET value (1mA = 2°F default; parameter 163).	0mA-4mA
ENTH	ODE STPT	C7400	Outdoor air enthalpy (A7) is less than free cooling setpoint (12mA = 75°F default, parameter 162).	12-19mA
GLOBAL	GLOBAL	24VAC Input Signal	Global input is energized by (P297-9). This setting is also used for outdoor air damper applications. Global input also brings on the blower. (This mode is NOT used when OAS signal is provided via network connection. GLO is only used when a 24VAC signal is used to energize the P297-9 GLO input.)	NA

\*Enthalpy includes effects of both temperature and humidity.

\*\*Energy management systems may require additional field-provided sensors; refer to manufacturer's instructions.

## K-Control Systems

The A55 Unit Controller provides all control function for the rooftop unit. Default operation requires a standard room thermostat or direct digital controller (DDC). The A55 can also control the unit from a zone temperature sensor. The A55 Unit Controller is a network controller when daisy-chained to the L Connection® Network Control System. For ease of configuration, the A55 can be connected to a PC with Unit Controller PC software installed.

### L-Indoor Air Quality (CO2) Sensor A63

The indoor air quality sensor monitors CO2 levels and reports the levels to the A55 Unit Controller. The board adjusts the economizer dampers according to the CO2 levels. The sensor is mounted next to the indoor thermostat or in the return air duct. Refer to the indoor air quality sensor installation instructions for proper adjustment. Wiring for the indoor air quality switch is shown on the temperature control section (C2) wiring diagram in back of this manual.

### M-Drain Pan Overflow Switch S149 (optional)

The overflow switch is used to interrupt cooling operation when excessive condensate collects in the drain pan. The N.C. overflow switch is connected to the M2 Unit Controller (A55) through DI-3. When the switch opens, the Unit Controller will shut off the unit. After a five-minute time out, the Unit Controller will verify the overflow switch position and restart the unit (if the switch has closed). The Unit Controller has a three-strike counter before the unit locks out. This means the Unit Controller will allow the overflow switch to open three times per thermostat demand. If the unit locks out, a reset of the Unit Controller is required after the switch has closed to restore unit operation.

### N-Smoke Detectors A17 and A64

Photoelectric smoke detectors are a factory installed option. The smoke detectors can be installed in the supply air section (A64), return air section (A17), or in both the supply and return air section. Wiring for the smoke detectors are shown on the temperature control section (C2) wiring diagram in back of this manual.

## O-Factory Installed-Hot Gas Reheat (optional)

### General

Hot Gas Reheat units provide a dehumidifying mode of operation. These units contain a reheat coil adjacent to and downstream of the evaporator coil. Reheat coil solenoid valve, L14, routes hot discharge gas from the compressor to the reheat coil. Return air pulled across the evaporator coil is cooled and dehumidified; the reheat coil adds heat to supply air. See FIGURE 34 for reheat refrigerant routing and FIGURE 35 for standard cooling refrigerant routing.

### P-Optional Cold Weather Kit (Canada only)

Electric heater is available to automatically control the minimum temperature in the gas burner compartment. Heater is C.G.A. certified to allow cold weather operation of unit down to -60° F (-50° C).

The kit includes the following parts:

- 1 - A heater assembly is installed on the vestibule of the heating compartment. Included in the box are the following:
  - a. Electric strip heat (HR6).
  - b. Thermostat switch (S59) is an auto-reset SPST N.C. switch which opens on a temperature drop. The switch is wired in series with 24v power and the combustion air blower switch. When the temperature drops below -30° F (-35° C) the switch opens and the gas heat section is de-energized. The switch automatically resets when the heating compartment temperature reaches -10° F (-12° C).
  - c. Thermostat switch (S60) is an auto-reset SPST N.C. switch which opens on a temperature rise. The switch is wired in series with HR6. When the temperature rises above 20° F (-7° C) the switch opens and the electric heater is de-energized. The switch automatically resets when the heating compartment temperature reaches -10° F (23.3° C).
  - d. Thermostat switch (S61) is an auto-reset SPST N.O. switch which closes on a temperature drop. The switch is wired in series with HR6. When temperature drops below 20° F (-7° C) the switch closes and electric heater is energized. The switch automatically opens when heating compartment temperature reaches 76° F (24° C).
- 2 - K125 heat shutoff relay de-energizes HR6 heaters when S60 or S61 thermostat switches open. K125 must be installed in the control section.
- 3 - Wire harness is routed between the heat section components and the unit control box. Follow instructions provided with kit for wire connections.

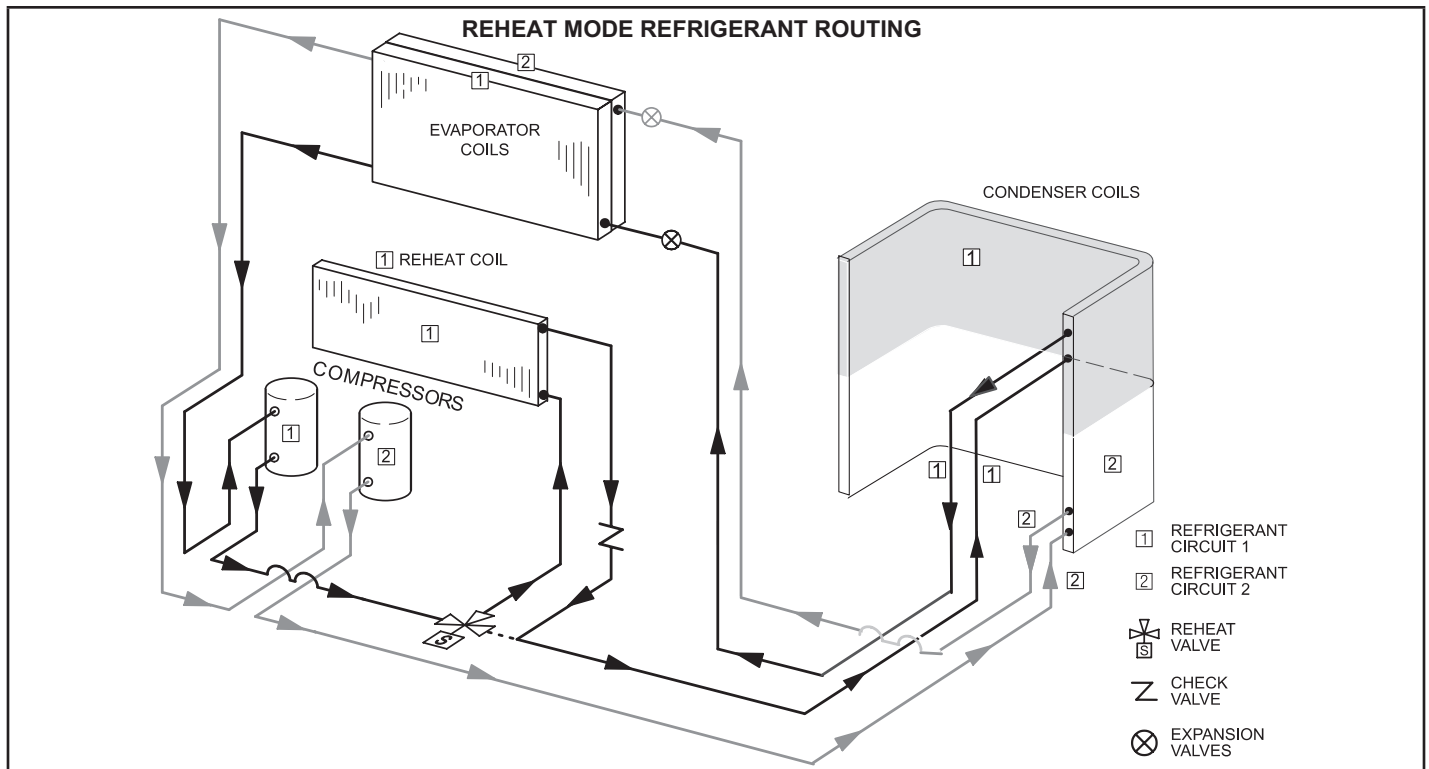

**FIGURE 34**

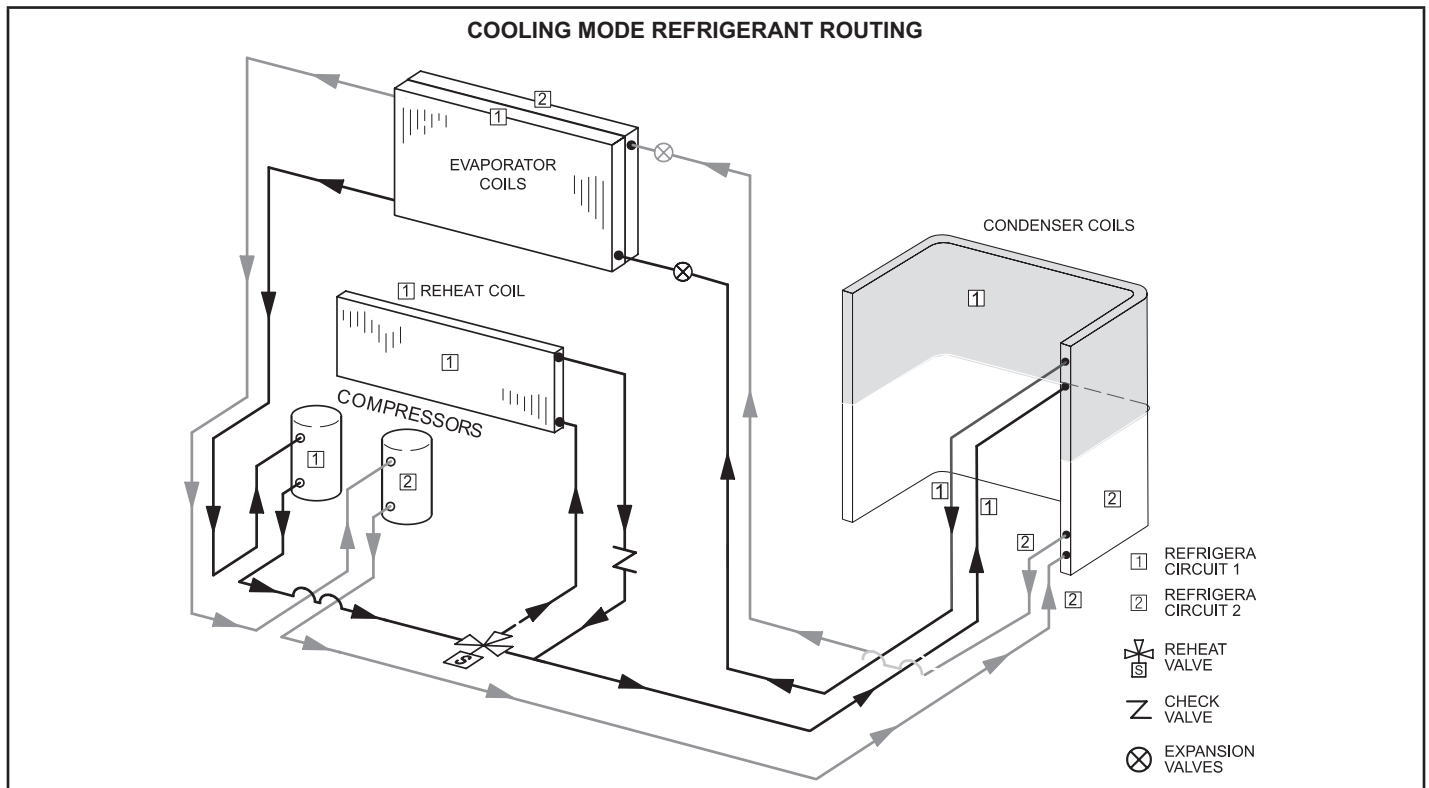

**FIGURE 35**

## L14 Reheat Coil Solenoid Valve

When Unit Controller input (Unit Controller J298-5 or J299-8) indicates room conditions require dehumidification, L14 reheat valve is energized (Unit Controller P269-3) and refrigerant is routed to the reheat coil.

### Reheat Setpoint

Reheat is factory-set to energize when indoor relative humidity rises above 60% (default). The reheat setpoint can be adjusted by changing Unit Controller Settings - Control menu. A setting of 100% will operate reheat from an energy management system digital output. The reheat setpoint can also be adjusted using an optional Network Control Panel (NCP). Reheat will terminate when the indoor relative humidity falls 3% (57% default) or the digital output de-energizes. The reheat deadband can be adjusted at Settings - Control menu.

### Check-Out

Test Hot Gas Reheat operation using the following procedure.

- 1 - Make sure reheat is wired as shown in wiring section.
- 2 - Make sure unit is in local thermostat mode.
- 3 - Select Unit Controller Service - Test.

The blower and compressor 1 (reheat) should be operating. Reheat mode will be appear on the Unit Controller display.

- 4 - Deselect Unit Controller Service - Test.

*Compressor 1 (reheat) and blower should de-energize.*

### Default Reheat Operation

TABLE 18

#### Reheat Operation - Two Cooling Stages - Default

T'stat & Humidity Demands	Operation
Reheat Only	Compressor 1 Full Load Reheat ON Blower Low
Reheat & Y1	Compressor 1 & 2 Full Load Reheat ON Blower High
Reheat & Y1 & Y2	Compressor 1 & 2 Full Load, Reheat OFF Blower High

\*If there is no reheat demand and outdoor air is suitable, free cooling will operate.

\*\*If there is no reheat demand and outdoor air is suitable, free cooling and compressor 1 will operate.

TABLE 19

#### Reheat Operation - Three Cooling Stages - Default

T'stat & Humidity Demands	Operation
Reheat Only	Compressor 1 Full Load, Reheat ON, Blower Low
Reheat & Y1	Compressor 1 & 2 Full Load, Reheat ON, Blower Medium
Reheat & Y1, Y2	Compressor 1 & 2 Full Load, Reheat ON, Blower High
Reheat & Y1, Y2, Y3	Compressor 1 & 2 Full Load, No Reheat OFF, Blower High

\*If there is no reheat demand and outdoor air is suitable, free cooling will operate.

\*\*If there is no reheat demand and outdoor air is suitable, free cooling and compressor 1 will operate.

### Q-Needlepoint Bipolar Ionizer

The ionizer was designed for low maintenance. The device should be checked semi-annually to confirm the brushes are clean for maximum output. The ionizer is located on the blower deck. See FIGURE 36.

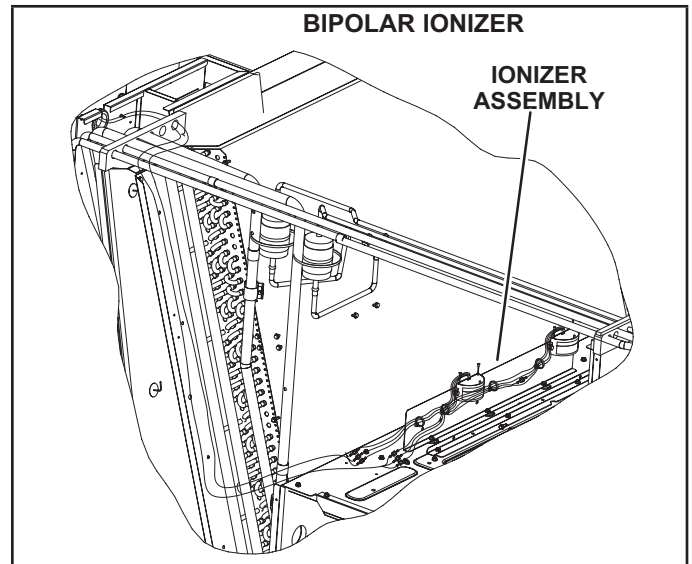
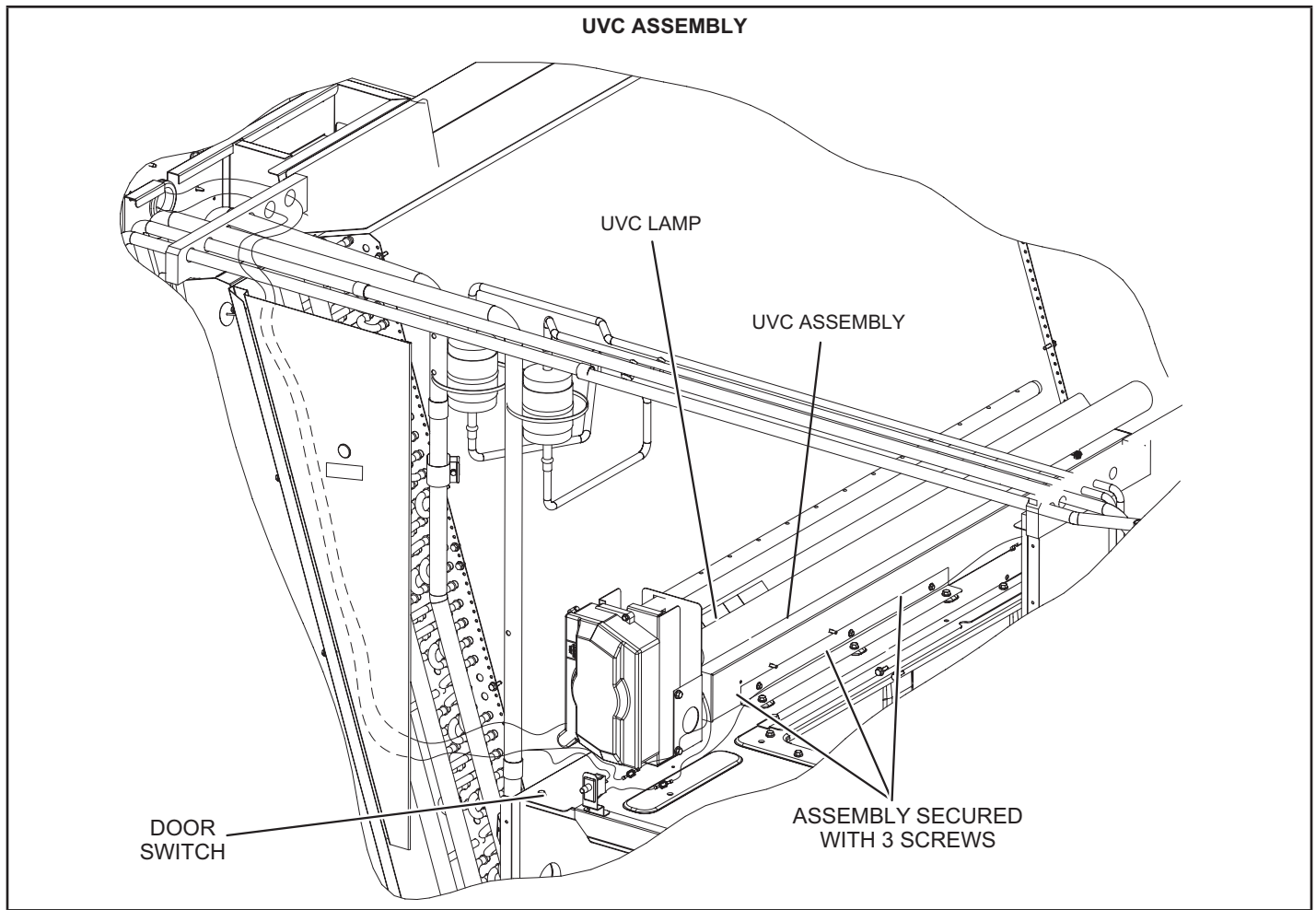

FIGURE 36



**FIGURE 37**

### R- UVC Light

When field-installed, use only UVC Light Kit assembly 106882-01 (21A93) with this appliance.

#### Factory-Installed UVC Light

When the UVC light is factory installed, the lamp is shipped in a foam sleeve. The lamp is attached to the UVC light assembly on the blower deck. See FIGURE 37. Remove the lamp and install into the UVC light assembly as shown in steps 2 through 11.

#### Annual Lamp Replacement

## **⚠ WARNING**

**Personal Burn Hazard.**

**Personal injury may result from hot lamps. During replacement, allow lamp to cool for 10 minutes before removing lamp from fixture.**

The lamp should be replaced every 12 months, as UVC energy production diminishes over time.

- 1 - Obtain replacement lamp 101087-01 for your germicidal light model.
- 2 - Disconnect power to the rooftop unit before servicing the UVC kit.
- 3 - Open the blower access door.
- 4 - Remove the screw in wire tie from the UVC assembly and disconnect the 4-pin connector from the lamp end.
- 5 - Remove and retain the (3) screws securing the UVC assembly. Carefully slide the complete UVC assembly out through the blower access door. See FIGURE 37.

- 6 - Allow 10 minutes before touching the lamps. Then, carefully remove the old lamp from the lamp holder clips.
- 7 - Wear cotton gloves or use a cotton cloth when handling the new lamp. Place the new lamp in the holder clips of the UVC assembly. Verify that the lamp flange at the connector end is sandwiched between the lamp holder clip and the sheet-metal end stop (see FIGURE 38).

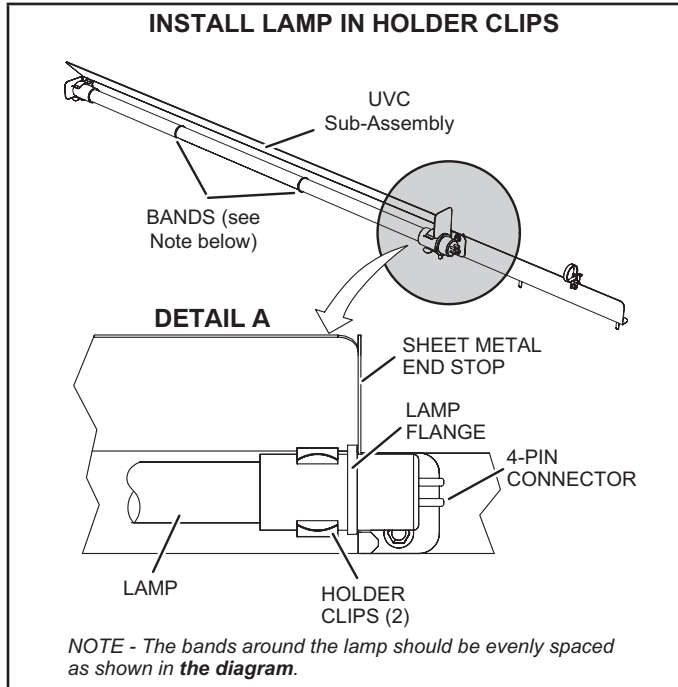

**FIGURE 38**

- 8 - Carefully place the UVC assembly on the blower deck. Line up the mounting holes on the UVC assembly with the mounting holes on the blower deck. See FIGURE 37. Use the retained screws provided to attach the UVC assembly in place.
- 9 - Close the blower access door.
- 10 - Reconnect power to the rooftop unit.
- 11 - Open the filter access door and look through the view port in the triangular sheet-metal panel to verify that the UVC light is on.

If UVC lamp does not come on:

- 1 - Check Power Wiring: Disconnect 1/4" QC (quick connects) of the UVC cable near the UVC assembly. With Power ON, use multimeter to test 110-230V at the 1/4"QC quick connects from the control panel.

- 2 - Check Lamp: Carefully remove the UVC assembly out of the rooftop unit. Use multimeter to test for continuity across each pair of pins at each end of the lamp.
- 3 - Check Lamp Installation: Make sure that lamp's pins snap properly into the lamp holder.

**LED(s) not illuminated**

*Power status LED not lit—Check that the lamp unit is connected to the proper power source and is wired correctly.*

*Lamp status LED(s) not lit—*

- 1 - Check that lamp 4-pin connectors are properly engaged.
- 2 - Ohm-check across the lamp pins to check for continuity of lamp filaments (see FIGURE 40).

Troubleshooting charts are provided to aid in determining the cause of any problems encountered (FIGURE 39 and FIGURE 40).

**Lamp Disposal**

**NOTE - UV Lamp Contains Mercury. Dispose According to Local, State, or Federal Laws. Refer to [www.lamprecycle.org](http://www.lamprecycle.org) or call 800-953-6669.**

**Proper Clean-up Technique in Case of Lamp Breakage**

Wear protective gloves, eye wear and mask.

Sweep the broken glass and debris into a plastic bag, seal the bag, and dispose of properly. Contact your local waste management office for proper disposal.

**Do not use a vacuum cleaner. Do not incinerate.**

**Maintenance**

- For all maintenance, contact a qualified HVAC technician.
- Read the maintenance instructions before opening unit panels.
- Unintended use of the unit or damage to the unit housing may result in the escape of dangerous UVC radiation. UVC radiation may, even in small doses, cause harm to the eyes and skin.
- Do not operate units that are obviously damaged.
- Do not discard the triangular UVC light shield or any barriers with an ultraviolet radiation symbol.
- Do not override the door interlock switch that interrupts power to the UVC light.
- Do not operate the UVC light outside of the unit.

# ⚠ DANGER

**Ultraviolet (UVC) Radiation hazard.**  
**Any exposure will cause significant eye damage and may cause skin damage.**  
**DO NOT look into UVC light source.**  
**Access panels must be in place during appliance operation.**

## UVC LIGHT TROUBLESHOOTING - POWER

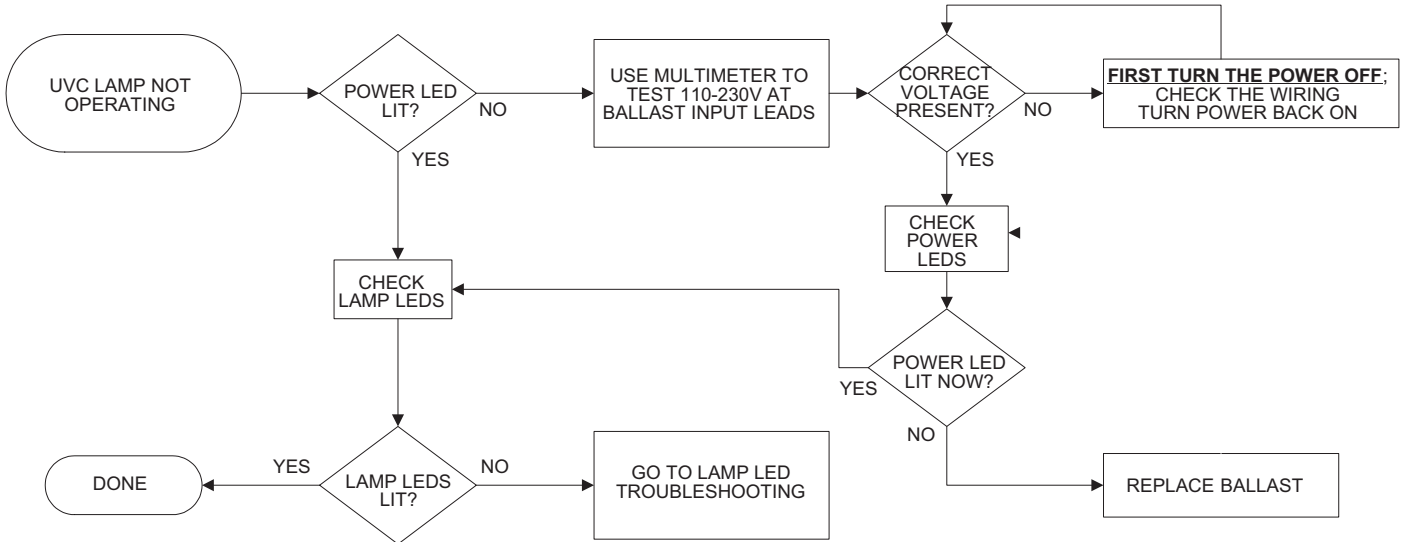

FIGURE 39

## UVC LIGHT TROUBLESHOOTING - LAMP

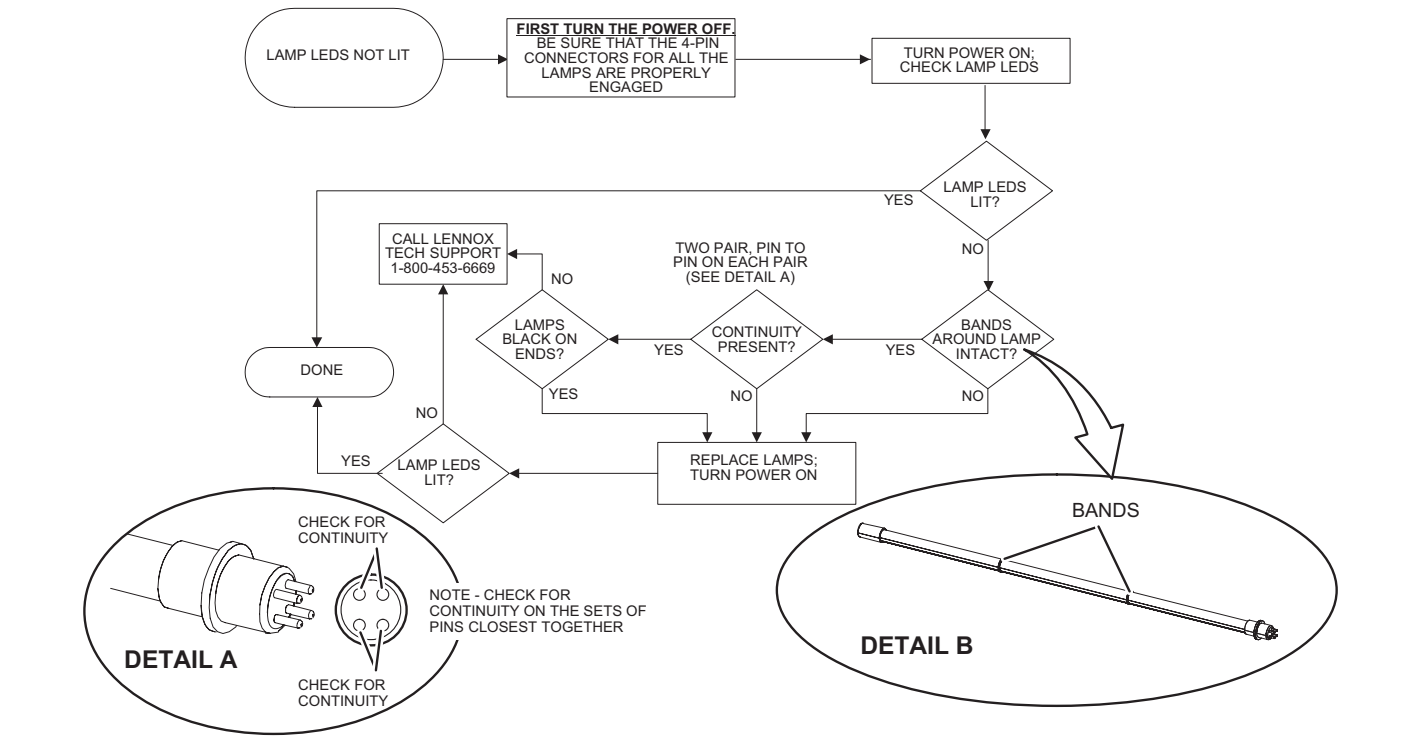

FIGURE 40

## VIII-Direct Drive Supply Air Inverter

If a test and balance contractor has not commissioned the unit, use this section to set supply air CFM.

### A-Set Blower Speed

- 1 - Use TABLE 20 to fill in field-provided, design specified blower CFM.

**TABLE 20**  
**Blower CFM Design Specifications**

Blower Speed	Design Specified CFM
Heating	
Cooling High	
Cooling Medium	
Cooling Low	
Ventilation	

- 2 - Use the following menu to enter the blower design specified CFM into the Unit Controller. Don't press "SAVE" until all CFM are entered. Refer to the Unit Controller manual provided with unit.

SETUP > TEST & BALANCE > BLOWER

- 3 - Once all four speeds are entered, the target (highest of the heating and cooling settings) CFM and default RPM will be displayed.

**Note** - When units are not equipped with heat, the Blower Heat speed will not be displayed. Blower Cooling High will be the first blower speed to appear.

- 4 - Measure the static pressure as shown in the Blower Start-Up section. Use the static pressure, target CFM and blower tables to determine the RPM needed. Values in the blower table reflect the static pressures taken in locations shown in FIGURE 10.
- 5 - Enter the RPM and repeat the previous step until the design CFM is reached.
- 6 - Press SAVE followed by MAIN MENU.

**Note** - Once the CFM settings are saved, the Unit Controller will set all other blower CFM.

### B-Set Damper Minimum Position

To maintain required minimum ventilation air volumes when the unit is in the occupied mode, two minimum damper positions must be set. The Unit Controller will open the dampers to "Min OCP Blwr Low" when blower CFM is BELOW a "midpoint" CFM. The Unit Controller will open the damper to "Min OCP Blwr High" when blower CFM is at or ABOVE the "midpoint" CFM.

The Unit Controller will calculate the "midpoint" CFM.

#### Set Minimum Position 1

Use the following menu in the Unit Controller to set "Min OCP Blwr Low" for the blower CFM below the "midpoint" CFM. When navigating into this menu, the Unit Controller will bring on the corresponding blower speed and allow damper position adjustment.

SETTINGS > RTU Options > EDIT PARAMETER > ENTER DATA ID - 9 > MIN DAMPER LOW BLOWER = X.X %

Measure the intake air CFM. If the CFM is lower than the design specified CFM for ventilation air, use the Unit Controller to increase the damper percent open. If the CFM is higher than specified, decrease the damper percent open.

**Note** - Intake air CFM can also be determined using the outdoor air temperature, return air temperature and mixed air temperature. Refer to the economizer or outdoor air damper installation instructions.

#### Set Minimum Position 2

Use the same menu in the Unit Controller to set "Min OCP Blwr High" for the blower CFM above the "midpoint" CFM. When navigating into this menu, the Unit Controller will bring on the corresponding blower speed and allow damper position adjustment.

SETTINGS > RTU OPTIONS > DAMPER > MIN DAMPER POSITION BLOWER ON HIGH = X.X %

Measure the intake air CFM. If the CFM is lower than the design specified CFM for ventilation air, use the Unit Controller to increase the damper percent open. If the CFM is higher than specified, decrease the damper percent open.

**Note** - Intake air CFM can also be determined using the outdoor air temperature, return air temperature and mixed air temperature. Refer to the economizer or outdoor air damper installation instructions.

**TABLE 21**  
**MINIMUM AND MAXIMUM CFM**

Gas Heat Minimum CFM		
Unit	Gas Heat Size	Airflow CFM*
LGT092H-150H	Standard	2150
	Medium	2550
	High	2600

## IX-Staged Supply Air Operation

This is a summary of cooling operation for both belt and direct drive blowers.

**Note** - During a dehumidification demand the blower operates at the highest speed. Free cooling is locked-out during reheat operation. Refer to Hot Gas Reheat start-up and operation section for details.

### A-Two-Stage Thermostat

#### 1-Economizer With Outdoor Air Suitable

##### Y1 Demand -

- Compressors Off
- Blower Cooling Low
- Dampers modulate to maintain 55° supply air

##### Y2 Demand -

- Compressors Off
- Blower Cooling High
- Dampers Modulate to maintain 55° supply air

**Note** - If dampers are at maximum open for three minutes, compressor 1 is energized and blower stays on cooling high.

#### 2-No Economizer or Outdoor Air Not Suitable

##### Y1 Demand -

- Compressor 1 On
- Blower Cooling Low

##### Y2 Demand -

- Compressor 1 and 2 On
- Blower Cooling High

## B-Three-Stage Thermostat OR Zone Sensor

#### 1-Economizer With Outdoor Air Suitable

##### Y1 Demand -

- Compressors Off
- Blower Cooling Low
- Dampers modulate to maintain 55° supply air

##### Y2 Demand -

- Compressors Off
- Blower Cooling High
- Dampers Modulate to maintain 55° supply air

**Note** - If dampers are at maximum open for three minutes, compressor 1 is energized and blower stays on cooling high. Economizer stays at maximum position after compressors are energized.

##### Y3 Demand -

- Compressors 1 and 2 On
- Blower Cooling High
- Dampers Maximum Open

#### 2-No Economizer or Outdoor Air Not Suitable

##### Y1 Demand -

- Compressor 1 On Part Load
- Blower Cooling Low

##### Y2 Demand -

- Compressor 1 On Part Load Compressor 2 On.
- Blower Cooling Medium

##### Y3 Demand -

- Compressors 1 and 2 On
- Blower Cooling High

# X-Wiring Diagrams and Sequence of Operation

## GAS HEAT Y and G Voltage

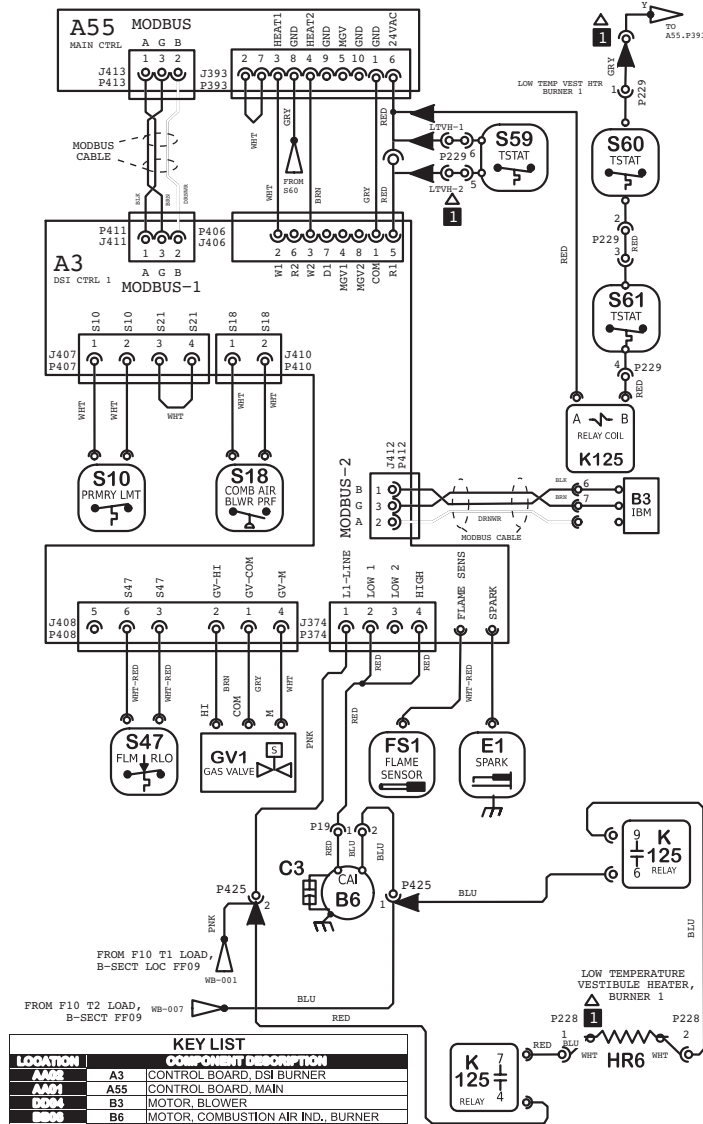

LOCATION	COMPONENT DESCRIPTION
A3	CONTROL BOARD, DSI BURNER
A55	CONTROL BOARD, MAIN
B3	MOTOR, BLOWER
B6	MOTOR, COMBUSTION AIR IND., BURNER
C3	CAPACITOR, CAI MOTOR
E1	IGNITER, SPARK, BURNER
FS1	SENSOR, FLAME, BURNER
GV1	VALVE, GAS, BURNER
HR6	HEATER, -50C LOW TEMP VEST, BURNER
K125	RELAY, LOW TEMP VEST HEATER, BURNER
K125	RELAY, LOW TEMP VEST HEATER, BURNER
S10	LIMIT, PRIMARY, BURNER
S18	SWITCH, COMB AIR BLWR PROOF, BURNER
S47	SWITCH, FLAME ROLLOUT, BURNER
S59	TSTAT, OPEN -20F, CLOSE -10F, BURNER
S60	TSTAT, OPEN 20F, CLOSE -10F, BURNER
S61	TSTAT, OPEN 50F, CLOSE 20F, BURNER

← DENOTES OPTIONAL COMPONENTS AND WIRING

**NOTES**

▲ -50C LOW TEMPERATURE VESTIBULE HEATER - OPTIONAL

Model: LG\* Series RTU - Gas Heat  
130k, 180k, 240k BtuH

Voltage: 208/240/3/60(Y), 460/3/60(G) WIRING DIAGRAM FLOW

Supersedes: XXXXXX-XX Form No: 538149-03 Rev: 0

© 2019				
HTG	CLG	CLG	ACCS	ACCS
SEC	SEC	SEC	SEC	SEC
A	B	B3	C	D

# GAS HEAT FOR J Voltage

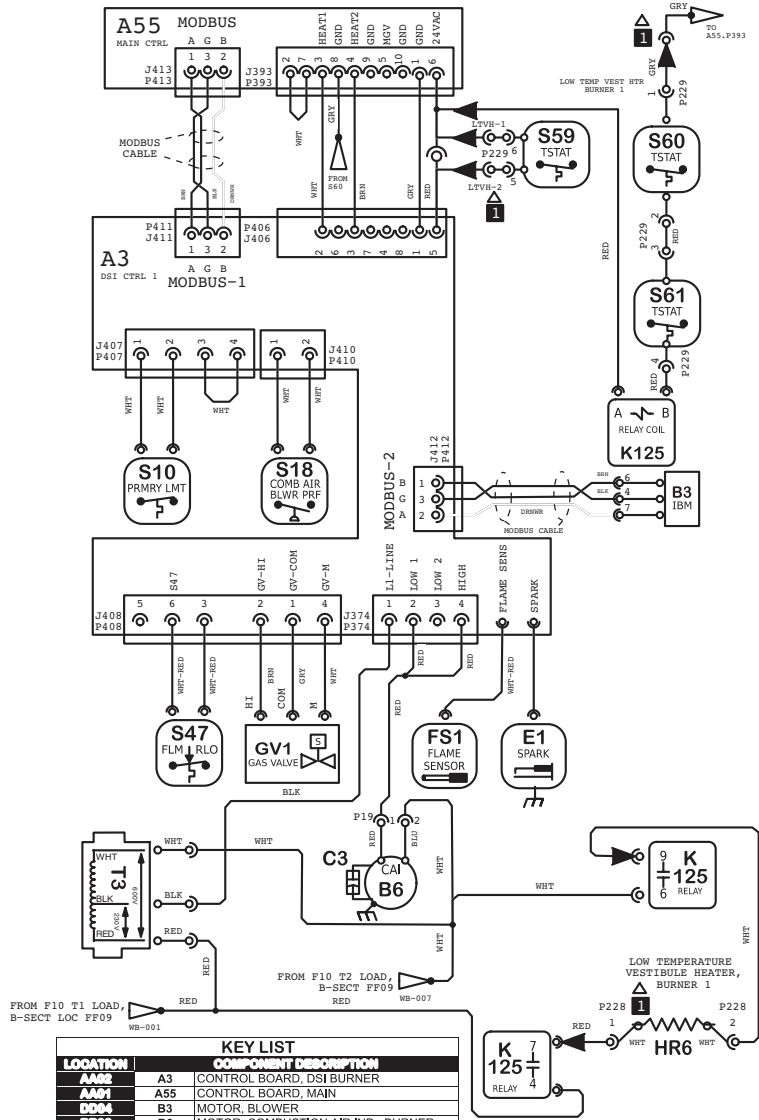

FROM F10 T1 LOAD, B-SECT LOC FF09 WB-001

FROM F10 T2 LOAD, B-SECT FF09 WB-007

KEY LIST		
LOCATION		COMPONENT DESCRIPTION
AA62	A3	CONTROL BOARD, DSI BURNER
AA61	A55	CONTROL BOARD, MAIN
DD04	B3	MOTOR, BLOWER
DD06	B6	MOTOR, COMBUSTION AIR IND., BURNER
DD08	C3	CAPACITOR, CAI MOTOR
DD09	E1	IGNITER, SPARK, BURNER
DD08	FS1	SENSOR, FLAME, BURNER
DD08	GV1	VALVE, GAS, BURNER
DD08	HR6	HEATER, -50C LOW TEMP VEST, BURNER
DD08/09	K125	RELAY, LOW TEMP VEST HEATER, BURNER
AA64	S10	LIMIT, PRIMARY, BURNER
BB64	S18	SWITCH, COMB AIR BLWR PRF, BURNER
AA65	S47	SWITCH, FLAME ROLLOUT, BURNER
AA61	S59	TSTAT, OPEN -20F, CLOSE 10F, BURNER
DD02	S60	TSTAT, OPEN 20F, CLOSE -10F, BURNER
DD08	S61	TSTAT, OPEN 50F, CLOSE 20F, BURNER
AA61/AA67	T3	TRANSFORMER, COMBUSTION AIR BLOWER

← DENOTES OPTIONAL COMPONENTS AND WIRING

**NOTES**

1 -50C LOW TEMPERATURE VESTIBULE HEATER -OPTIONAL

Model: LG\* Series RTU - Gas Heat  
130k, 180k, 240k BtuH

Voltage: 575/3/60 (J)

Supersedes: XXXXXX-XX Form No: 538173-02 Rev: 0

© 2019

HTG	CLG	CLG	ACCS	ACCS
SEC	SEC	SEC	SEC	SEC
A	B	B3	C	D

WIRING DIAGRAM FLOW

## GAS HEAT SEQUENCE OF OPERATION LGT092H-150H

### First Stage Heat:

- 1 - Heating demand initiates at W1 in the thermostat.
- 2 - 24VAC is routed through the A55 unit controller to A3 Ignition Control. The Ignition control then routes the 24VAC to the N.C. primary limit S10. The A3 Ignition control energizes the combustion air blower B6.
- 3 - After the combustion air blower B6 has reached full speed, the combustion air proving switch S18 contacts close. The A3 routes 24VAC through N.C. burner flame roll-out switch S47 and the closed contacts of combustion air proving switch S18 to energize the ignition module A3.
- 4 - After a 30 second delay A3 energizes the ignitor and LO terminal (low fire) of gas valve GV1.

### Second Stage Heat:

- 5 - With first stage heat operating, an additional heating demand initiates W2 in the thermostat.
- 6 - A second stage heating demand is received by A55 Unit Controller.
- 7 - A55 provides the 24VAC to the A3 Ignition control. This is routed to the HI Terminal (high fire) of gas valve GV1.

### End of Second Stage Heat:

- 8 - Heating demand is satisfied. Terminal W2 (high fire) is de-energized.
- 9 - Terminal HI of GV1 is de-energized by A3 control module.

### End of First Stage Heat:

- 10 - Heating demand is satisfied. Terminal W1 (low fire) is de-energized.
- 11 - Ignition A3 is de-energized by control module A55 in turn de-energizing terminal LO of GV1. Combustion air blower relay K13 located in the A3 ignition control is also de-energized.

### Optional Low Ambient Kit:

(C.S.A. -50° C Low Ambient Kit)

- 12 - Line voltage (or transformer T20 in 460V and 575V only) is routed through the low ambient kit fuses F20 and N.C. low ambient kit thermostats S60 and S61, to energize low ambient kit heater HR6.

# ELECTRONIC OR ELECTROMECHANICAL THERMOSTAT

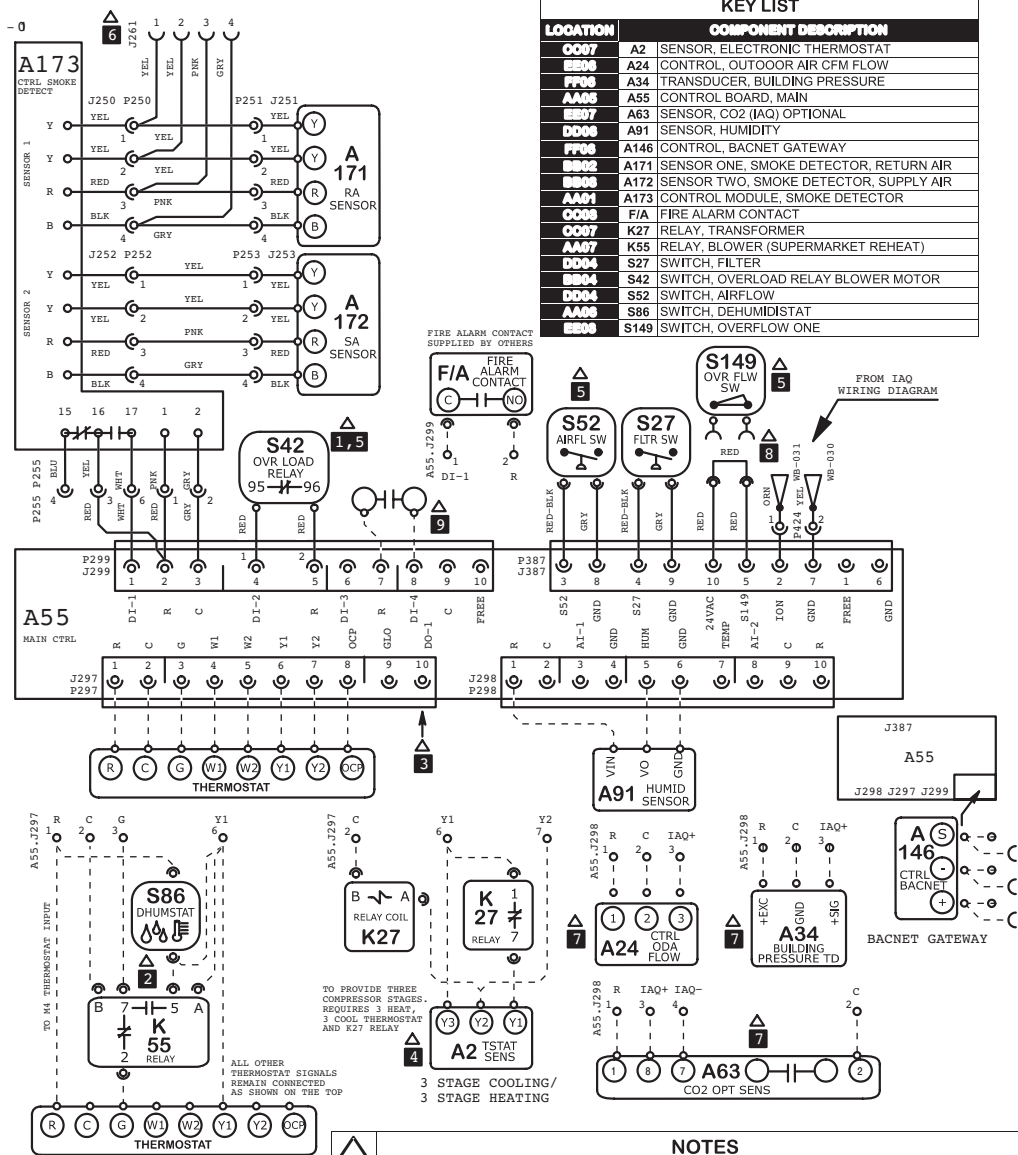

KEY LIST		LOCATION	COMPONENT DESCRIPTION
0007	A2	SENSOR	ELECTRONIC THERMOSTAT
0006	A24	CONTROL	OUTDOOR AIR CFM FLOW
FF06	A34	TRANSDUCER	BUILDING PRESSURE
AA05	A55	CONTROL BOARD	MAIN
0007	A63	SENSOR	CO2 (IAQ) OPTIONAL
DD06	A91	SENSOR	HUMIDITY
FF06	A146	CONTROL	BACNET GATEWAY
0002	A171	SENSOR ONE	SMOKE DETECTOR, RETURN AIR
0003	A172	SENSOR TWO	SMOKE DETECTOR, SUPPLY AIR
AA01	A173	CONTROL MODULE	SMOKE DETECTOR
0009	F/A	FIRE ALARM CONTACT	
0007	K27	RELAY	TRANSFORMER
AA07	K55	RELAY	BLOWER (SUPERMARKET REHEAT)
DD04	S27	SWITCH	FILTER
0004	S42	SWITCH	OVERLOAD RELAY BLOWER MOTOR
DD04	S52	SWITCH	AIRFLOW
AA09	S86	SWITCH	DEHUMIDISTAT
0009	S149	SWITCH	OVERFLOW ONE

- NOTES**
- 1 FOR MOTORS WITH S42 EXTERNAL OVERLOAD LESS INVERTER, SEE INVERTER WITH BY PASS FOR S42 HOOK UP
  - 2 USE S86 DEHUMIDISTAT AND K55 FOR OPTIONAL SUPERMARKET REHEAT SCHEME, PRODIGY PARAMETERS NEED TO BE MODIFIED UNDER THE SETTINGS MENU OR VIA UC SOFTWARE FOR SIMULTANEOUS HEATING AND COOLING
  - 3 P297-10 (SR) IS SERVICE RELAY OUTPUT (24VAC) IF USED CONNECT TO AN INDICATOR LIGHT
  - 4 THERMOSTAT HOOKUP FOR PROGRAMMABLE CONFIGURATION OF THE BOARD (A55)
  - 5 PRODIGY SETTINGS MUST BE MODIFIED WHEN S42, S52, S149 ARE INSTALLED
  - 6 CONNECT P252 OF A172 SENSOR TO J261 ON SUPPLY AIR SMOKE DETECTOR ONLY
  - 7 FROM A63, A34 & A24, ONLY ONE CAN BE USED AT A TIME
  - 8 REMOVE JUMPER TO INSTALL S149
  - 9 EXTERNAL HUMIDITROL CONTACTS

Model: LC, LG, LH, LD Series RTU  
 Thermostat  
 Voltage: All Voltages  
 Supersedes: N/A Form No: 538078-01 Rev: 1

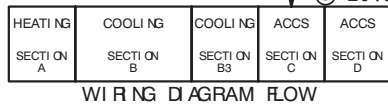

# ECONOMIZER

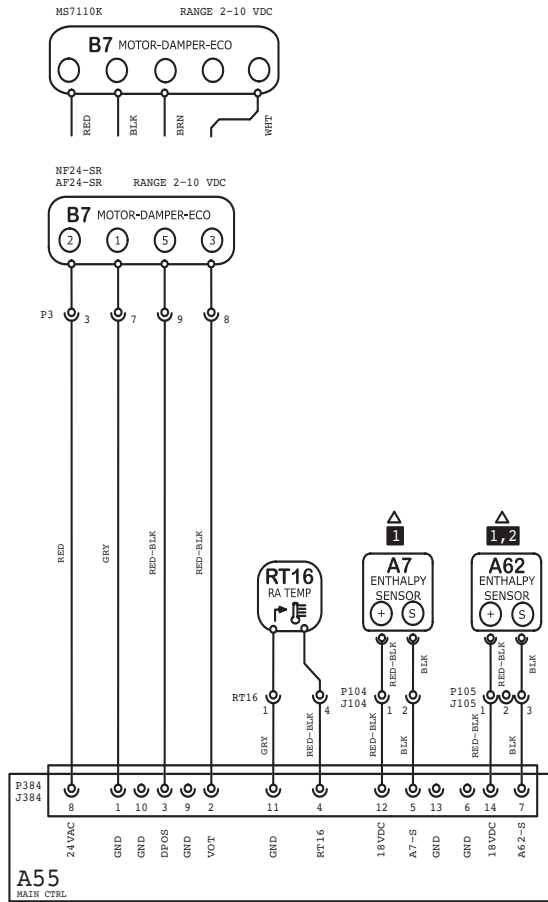

NOTES	
1	A7 AND A62 NOT USED FOR SENSIBLE TEMPERATURE CONTROL
2	FOR UNIT DIFFERENTIAL ENTHALPY CONTROL, ADD A62 RETURN AIR ENTHALPY SENSOR

KEY LIST	
LOCATION	COMPONENT DESCRIPTION
CC05	A7 SENSOR, SOLID STATE ENTHALPY
AA05	A55 CONTROL BOARD, MAIN
DD05	A62 SENSOR, ENTHALPY INDOOR
BB02	B7 MOTOR, DAMPER ECONOMIZER
CC05	RT16 SENSOR, RETURN AIR TEMP

Model: LC, LG, LH, LD Series RTU  
Economizer & Motorized OAD

Voltage: All Voltages

Supersedes: N/A

Form No: 538072-01 Rev: 1

© 2019

HTG SEC A	CLG SEC B	OLG SEC B3	ACCS SEC C	ACCS SEC D
-----------------	-----------------	------------------	------------------	------------------

WIRING DIAGRAM FLOW

538364-01

01

02

03

04

05

06

07

08

09

10

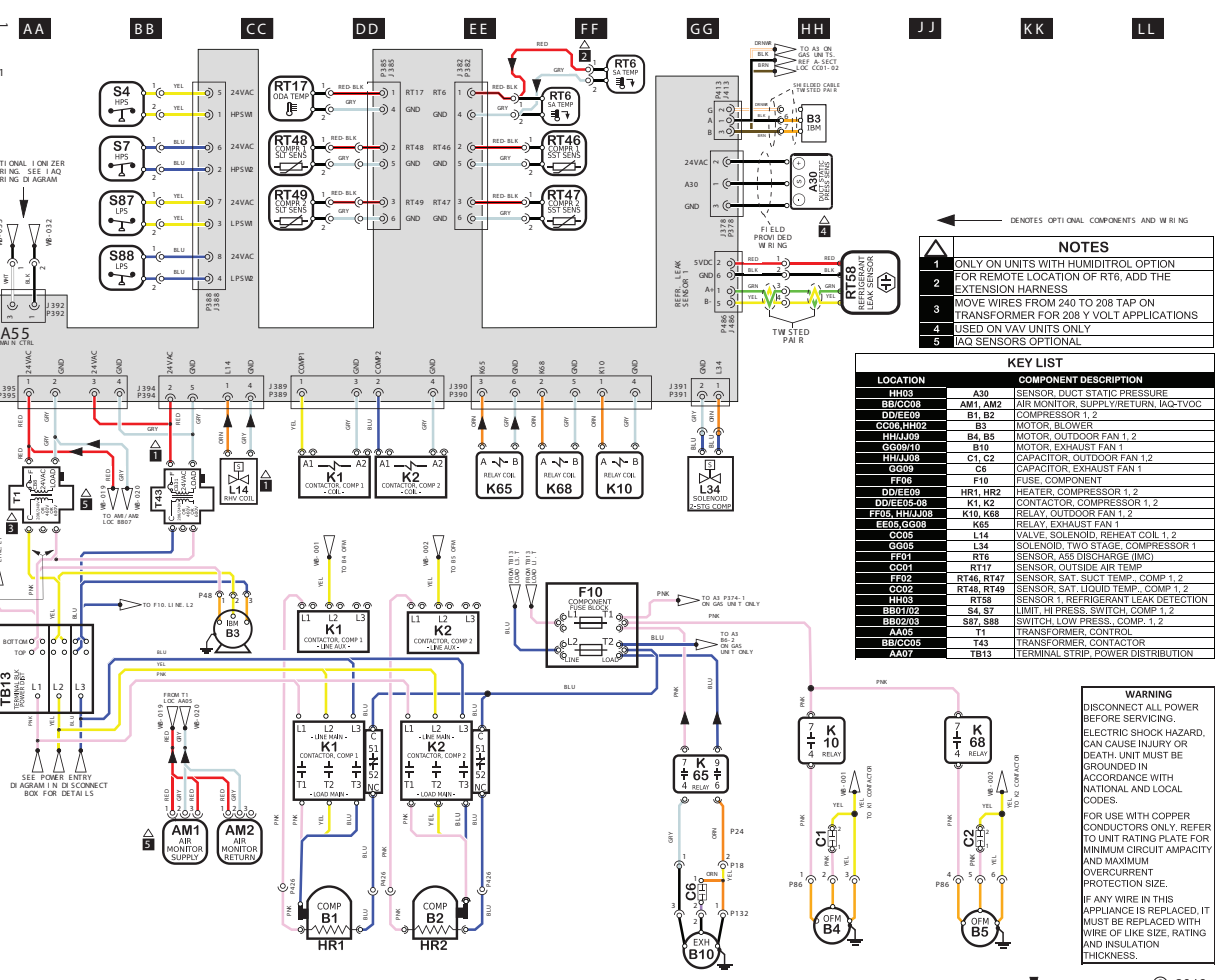

- NOTES
- 1 ONLY ON UNITS WITH HUMIDITROL OPTION
  - 2 FOR REMOTE LOCATION OF RT6, ADD THE EXTENSION HARNESS
  - 3 MOVE WIRES FROM 240 TO 208 TAP ON TRANSFORMER FOR 208 VOLT APPLICATIONS
  - 4 USED ON VAV UNITS ONLY
  - 5 IAQ SENSORS OPTIONAL

KEY LIST

LOCATION	COMPONENT DESCRIPTION
HH03	A30 SENSOR, DUCT STATIC PRESSURE
BB/CC08	AM1, AM2 AIR MONITOR, SUPPLY/RETURN, IAQ-TVOC
DD/EE09	B3 COMPRESSOR 1, 2
CC08, HH02	B4, B5 MOTOR, BLOWER
HH/LL09	B10 MOTOR, OUTDOOR FAN 1, 2
CC09/10	B10 MOTOR, EXHAUST FAN 1
HH/LL08	Cl, C2 CAPACITOR, OUTDOOR FAN 1,2
GG09	C6 CAPACITOR, EXHAUST FAN 1
FF06	F10 FUSE, COMPONENT
DD/EE09	HR1, HR2 HEATER COMPRESSOR 1, 2
DD/EE05-08	K1, K2 CONTACTOR, COMPRESSOR 1, 2
FF05, HH/LL08	K10, K68 RELAY, OUTDOOR FAN 1, 2
EE03, CC05	K65 RELAY, EXHAUST FAN 1
CC05	L14 VALVE, SOLENOID, REHEAT COIL 1, 2
GG05	L34 SOLENOID, TWO STAGE, COMPRESSOR 1
FF01	RT6 SENSOR, ASH DISCHARGE (IMO)
CC01	RT17 SENSOR, OUTSIDE AIR TEMP
FF02	RT46, RT47 SENSOR, SAT. SUCT TEMP, COMP 1, 2
CC02	RT48, RT49 SENSOR, SAT LIQUID TEMP, COMP 1, 2
NH03	RT58 SENSOR 1, REFRIGERANT LEAK DETECTION
BB/LL02	S4, S7 LIMIT, HI PRESS, SWITCH, COMP 1, 2
HH02/03	S87, S88 SWITCH, LOW PRESS, COMP. 1, 2
AA05	T1 TRANSFORMER, CONTROL
BB/CC05	T43 TRANSFORMER, CONTACTOR
AA07	TB13 TERMINAL STRIP, POWER DISTRIBUTION

**WARNING**  
DISCONNECT ALL POWER BEFORE SERVICING. ELECTRIC SHOCK HAZARD. CAN CAUSE INJURY OR DEATH. UNIT MUST BE GROUNDED IN ACCORDANCE WITH NATIONAL AND LOCAL CODES.  
FOR USE WITH COPPER CONDUCTORS ONLY. REFER TO UNIT RATING PLATE FOR MINIMUM CIRCUIT AMPACITY AND MAXIMUM OVERCURRENT PROTECTION SIZE.  
IF ANY WIRE IN THIS APPLIANCE IS REPLACED, IT MUST BE REPLACED WITH WIRE OF LIKE SIZE, RATING AND INSULATION THICKNESS.

Product: LCT, LGT B Box Cooling Diagram with Higher SCCR

Voltage: 208-230V, 460V, 575V/ 3-/ 60Hz (Y/G/J)  
Supersedes: XXXXX-XX Form No: 538364-01 Rev: 1

WIRING DIAGRAM FLOW

HEATING SECTION A	COOLING SECTION B	COOLING SECTION C	ACCS SECTION C	ACCS SECTION D

10x12 CUT SIZE

REV	EC NO.	DATE	BY	APVD	REVISION NOTE
---	CN-012081C	04-29-2024	EFP	MCF	ORIGINATED AT PD&R CARROLLTON, TX
001	CN-012081W	10-07-2024	EFP	FXY	UPDATED P18 CONNECTORS FROM 3 & 4 TO 1 & 2

FIGURE 41

## LGT092H-150H SEQUENCE OF OPERATION

### Power:

- 1 - Line voltage through the S48 unit disconnect, TB2 terminal block, or CB10 circuit breaker energizes the T1 transformer. T1 provides 24VAC power to A55 Unit Controller which provides 24VAC to the unit cooling, heating and blower controls.
- 2 - Line voltage is also routed to compressor crankcase heaters, compressor contactors, the blower motor, condenser fan relays and exhaust fan relays.

### Blower Operation:

- 3 - The A55 Unit Controller module receives a demand from thermostat terminal G.
- 4 - B3 receives the pre-set blower setting through MODUS.

### Economizer Operation:

- 5 - A55 receives a demand and energizes exhaust fan relay K65 with 24VAC at 50% outside air damper open (adjustable).
- 6 - N.O. K65-1 and N.O. K65-2 both close, energizing exhaust fan motor B10.

### 1st Stage Cooling (compressor B1)

- 7 - A55 receives a Y1 thermostat demand.
- 8 - After A55 proves N.C. low pressure switch S87, RT46 reading above freeze point and N.C. high pressure switch S4, compressor contactor K1 is energized.
- 9 - N.O. contacts K1-1 close energizing compressor B1. Crankcase heater HR1 is de-energized.
- 10 - At the same time, A55 energizes condenser fan relays K10 and K68.
- 11 - N.O. contacts K10-1 close energizing condenser fan B4 and N.O. contacts K68-1 close energizing condenser fan B5.

### 2nd Stage Cooling (compressor B2 is energized)

- 12 - A55 receives a Y2 thermostat demand.
- 13 - After A55 proves N.C. low pressure switch S88, RT47 reading above freeze point, and N.C. high pressure switch S7, compressor contactor K2 is energized.
- 14 - N.O. contacts K2-1 close energizing compressor B2. Crankcase heater HR2 is de-energized.

### 3rd Stage Cooling (compressor B1 in full load and compressor 2 is energized)

- 15 - A55 receives a Y3 thermostat demand (Y1 + Y2 thermostat inputs).
- 16 - A55 sends 24VAC to B1 compressor solenoid (L34), B1 compressor runs at full load.

## DIRECT DRIVE BLOWER SEQUENCE OF OPERATION / TROUBLESHOOTING

### Blower Operation:

- 1 - Line voltage is routed to B3 blower motor through TB2 terminal strip, TB13 terminal strip and J/P48 terminals 1, 2 and 3.
- 2 - B3 blower motor runs internal diagnostics to check for proper temperature, voltage, etc. (KL2-2 and -3). This process takes approximately 10 seconds. Refer to the Failure Handling/Troubleshooting section.
- 3 - A55 Unit Controller receives a thermostat demand. After the A55 proves (P259-7 and -6) that B3 blower motor internal relay (KL2-2 and -3) is closed, B3 blower motor is energized (0-10VDC from P259-4 to KL3-4). B3 blower motor controls are grounded through KL2-2 and -3 to A55 P259-6.
- 4 - If configured, A55 checks S52 blower proving switch to make sure it closes within 16 seconds of the 0-10VDC signal being sent to B3 blower motor.

### Blower Fault Sequence Direct Drive Motor - No S52:

- 1 - Line voltage is provided to B3 blower motor.
- 2 - After 10 seconds, the B3 blower motor internal relay does not close.
- 3 - Alarm 186 is set by the A55 Unit Controller, de-energizing unit. If one of the "Error" failures listed in TABLE 22 occurs ("Warning" failures will not set Alarm 186), service is required. Refer to the Failure Handling/Troubleshooting section.
- 4 - If B3 blower motor internal relay closes continue to next step.
- 5 - A55 sends 0-10VDC signal to B3 blower motor.
- 6 - \During B3 blower motor operation, the internal motor relay opens.
- 7 - \Alarm 186 is set by A55 and de-energizes the unit. Service is required. Refer to the Failure Handling/Troubleshooting section.

### Blower Fault Sequence Direct Drive Motor - With S52 (If Configured):

- 1 - A55 Unit Controller sends 0-10VDC signal to B3 blower motor.
- 2 - After 16 seconds, if S52 blower proving switch remains open, A55 will remove 0-10VDC signal for 5 minutes.
- 3 - A55 sends 0-10VDC signal to B3 blower motor.
- 4 - After 16 seconds, if S52 blower proving switch remains open, A55 will remove 0-10VDC signal for another 5 minutes.
- 5 - After the third try, A55 will de-energize the unit. Service is required.

### Failure Handling/Troubleshooting:

- 1 - Follow TABLE 22 to troubleshoot possible failures that would cause Alarm 186 to set.
- 2 - BEFORE DETERMINING THAT THE BLOWER ASSEMBLY HAS FAILED, use the A55 Unit Controller to clear delays and operate the blower.
- 3 - Main Menu > Service > Offline > Clear Delays > Yes > Save
- 4 - Main Menu > Service > Test > Blower
- 5 - Observe if the blower operates or if Alarm 186 sets again.
- 6 - If blower does not operate and Alarm 186 is set again, blower assembly must be replaced.
- 7 - If blower assembly does operate, wait a minimum of 30 minutes to ensure Alarm 186 is not set again.

**TABLE 22  
DIRECT DRIVE BLOWER MOTOR TROUBLESHOOTING**

Failure	Error	Warning	Reason	Troubleshoot
Locked Rotor	o		No changes in hall signals within 2000ms	Check for obstruction keeping impeller from rotating
Braking Mode		o	Warning, no error code set, Motor start not possible after 20 sec	Check for secondary airflow source in the system causing the impeller to rotate backwards when off
Hall Error	o		Combination of 3 hall signals gives false signal after one rotation	Measure voltage across each leg, Check electrical connections
Power Module Overheated	o		Temperature > 115°C	Check operating conditions in blower compartment, Check for high motor load (current draw), Check for corrosion-free and secure electrical connections
Motor Overheated	o		Motor over-temperature protector opens	
Gate Driver Error	o		Internal software fault	Measure voltage across each leg, Check electrical connections
Phase Failure	o		Input voltage has phase imbalance	Measure voltage across each leg, Check electrical connections, Repair low/high voltage leg(s)
DC Link Voltage Low	o		Rectified DC link voltage is too low	
DC Link Over-voltage	o		Rectified DC link voltage is too high	
Line Over-voltage	o		Line voltage too high	
Line Under-voltage	o		Line voltage too low	
Communication Error			Internal communication failure. Not connected with master/slave wiring	Check low voltage wiring connections
DC Link Voltage Low		o	Warning, not low enough to set error code	Measure voltage across each leg, Check electrical connections, Repair low/high voltage leg(s)
Electronics Temp High		o	Warning, not high enough to set error code, Temperature > 95°C	Check operating conditions in blower compartment, Check for high motor load (current draw), Check for corrosion-free and secure electrical connections
Power Module Temp High		o	Warning, not high enough to set error code, Temperature > 105°C	
Motor Temp High		o	Warning, not high enough to set error code, Temperature > 130°C	

## XI-Decommissioning

Before carrying out this procedure, it is essential that the technician is completely familiar with the equipment and all its detail. It is recommended good practice that all refrigerants are recovered safely. Prior to the task being carried out, an oil and refrigerant sample shall be taken in case analysis is required prior to re-use of recovered refrigerant. It is essential that electrical power is available before the task is commenced.

Steps to ensure this are:

- Become familiar with the equipment and its operation,
- Isolate the system electrically,
- Ensure that before attempting the procedure that mechanical handling equipment is available, if required, for handling refrigerant cylinders, and that all personal protective equipment is available and being used correctly while the recovery process is supervised at all times by a competent person and that the recovery equipment and cylinders conform to the appropriate standards.

Additionally, pump down refrigerant system, if possible, and if a vacuum is not possible, make a manifold so that refrigerant can be removed from various parts of the system. Make sure that cylinders are situated on the scales before recovery takes place. Start the recovery machine and operate in accordance with instructions. Do not overfill cylinders (no more than 80 % volume liquid charge). Do not exceed the maximum working pressure of the cylinder, even temporarily. When the cylinders have been filled correctly and the process completed, make sure that the cylinders and the equipment are removed from site promptly and all isolation valves on the equipment are closed off. Recovered refrigerant shall not be charged into another refrigerating system unless it has been cleaned and checked.

Equipment shall be labeled stating that it has been decommissioned and emptied of refrigerant. The label shall be dated and signed. For appliances containing flammable refrigerants, ensure that there are labels on the equipment stating the equipment contains flammable refrigerant.

Under no circumstances shall potential sources of ignition be used in the searching for or detection of refrigerant leaks. A halide torch (or any other detector using a naked flame) shall not be used. Electronic leak detectors may be used to detect refrigerant leaks but, in the case of flammable refrigerants, the sensitivity may not be adequate, or may need re-calibration. (Detection equipment shall be calibrated in a refrigerant-free area)

Ensure that the detector is not a potential source of ignition and is suitable for the refrigerant used. Leak detection equipment shall be set at a percentage of the LFL of the refrigerant and shall be calibrated to the refrigerant employed, and the appropriate percentage of gas (25 % maximum) is confirmed. Leak detection fluids are also suitable for use with most refrigerants but the use of detergents containing chlorine shall be avoided as the chlorine may react with the refrigerant and corrode the copper pipe-work. If a leak is suspected, all naked flames shall be removed/extinguished. If a leakage of refrigerant is found which requires brazing, all of the refrigerant shall be recovered from the system, or isolated (by means of shut off valves) in a part of the system remote from the leak.

When breaking into the refrigerant circuit to make repairs – or for any other purpose – conventional procedures shall be used. However, for flammable refrigerants it is important that best practice be followed, since flammability is a consideration. The following procedure shall be adhered to:

- Safely remove refrigerant following local and national regulations,
- Evacuate the circuit,
- Purge the circuit with inert gas,
- Evacuate,
- Purge with inert gas,
- Open the circuit.

The refrigerant charge shall be recovered into the correct recovery cylinders if venting is not allowed by local and national codes. For appliances containing flammable refrigerants, the system shall be purged with oxygen-free nitrogen to render the appliance safe for flammable refrigerants. This process might need to be repeated several times. Compressed air or oxygen shall not be used for purging refrigerant systems. Refrigerant purging shall be achieved by breaking the vacuum in the system with oxygen-free nitrogen and continuing to fill until the working pressure is achieved, then venting to atmosphere, and finally pulling down to a vacuum. This process shall be repeated until no refrigerant is within the system. When the final oxygen-free nitrogen charge is used, the system shall be vented down to atmospheric pressure to enable work to take place. Ensure that the outlet for the vacuum pump is not close to any potential ignition sources and that ventilation is available.