

# PACKAGED UNITS KITS AND ACCESSORIES

506401-01  
6/2026  
Supersedes 6/2024

## DISCONNECT KIT

### INSTALLATION INSTRUCTIONS FOR DISCONNECT SWITCH KIT USED ON LG/LC/LH/LD/ KG/KC/KH 156-300 PACKAGED UNITS

#### Shipping and Packing List

Package 1 of 1 contains:

- 1- Disconnect switch assembly
- 1- Disconnect door assembly
- 1- Bag assembly containing:
  - 4- #8-32 X 1/2" TFS screws 4-Wire ties
  - 15- #10 Screws (10 in 54W85, 54W86, & 54W87, 90W82)
  - 2- Labels (S48, L123)
  - 2- Terminal covers (54W85, 54W88, 54W88)
- 1- Disconnect box (54W88, 54W89, 90W82)

#### Application

See table 1 for usage. Disconnect size depends on unit voltage, blower motor horsepower, and electric heat; refer to product specifications to determine which size disconnect to use with each unit.

TABLE 1

Unit	Disconnect Kit		Size (Amps)
LC/KC/KH/LH	604551-01;	54W85	80
	604551-02;	54W86	150
	604551-03;	54W87	250
LG/LD/KG	604551-04;	54W88	80
	604551-05;	54W89	150
	604551-09;	90W82	250

### **⚠ WARNING**

Improper installation, adjustment, alteration, service or maintenance can cause property damage, personal injury or loss of life. Installation and service must be performed by a qualified installer, service agency or the gas supplier.

### **⚠ CAUTION**

Danger of sharp metallic edges. Can cause injury. Take care when servicing unit to avoid accidental contact with sharp edges.

#### Installation

- 1 - Disconnect all power to unit. Use an approved NEC electrical lockout on the main panel. Remove lockout once installation is complete.
- 2 - Locate the panel or patch plate covering the unit fuse block, terminal block, or disconnect box opening. All are located on the right corner mullion when facing the blower access door.
- 3 - Remove and discard the panel or patch plate.
- 4 - *LC/LH/KC/KH 80 Amp Units -*

Remove and discard TB2 terminal block located in make-up box. See figure 1. Install the disconnect switch assembly and reconnect wires from fuse block to TB2 on the disconnect switch assembly. Trim wires as needed. See figure 2.

#### *LC/LH/KC/KH 150, 250 Amp Units -*

Remove and discard TB2 terminal block located in make-up box. See 3. Install the disconnect switch assembly and reconnect wires from fuse block to the disconnect switch assembly. Trim wires as needed. See figure 4.

**NOTE - On units with electric heat, refer to the electric heat installation instruction.**

#### *LG/LD Units:*

Remove and discard TB2 terminal block located in the make-up box. See figure 5. Install the disconnect switch assembly and reconnect wires coming from TB13. Trim wires as needed. See figure 6 and 7.

#### *KG/LGX Units -*

Install the disconnect box assembly and secure with four #10 screws; use top and bottom mounting holes. Connect wires (supplied in kit) between TB13 and the disconnect switch assembly. Trim wires as needed. On M-Volt units, connect N-block on control pane to N-block in disconnect box. See figure 8, 9, and 10.

- 5 - Affix L123 label below disconnect to indicate line voltage connections. Affix S48 below L123 label.

**NOTE - Disconnects provided in this kit are bi-directional; disregard line and load side nomenclature on 80 amp disconnects.**

- 6 - Install door panel supplied in kit.



**LC/LH/KC/KH Units:**

**Disconnect box  
from factory**

**Disconnect box  
with field installed  
80 Amp disconnect switch**

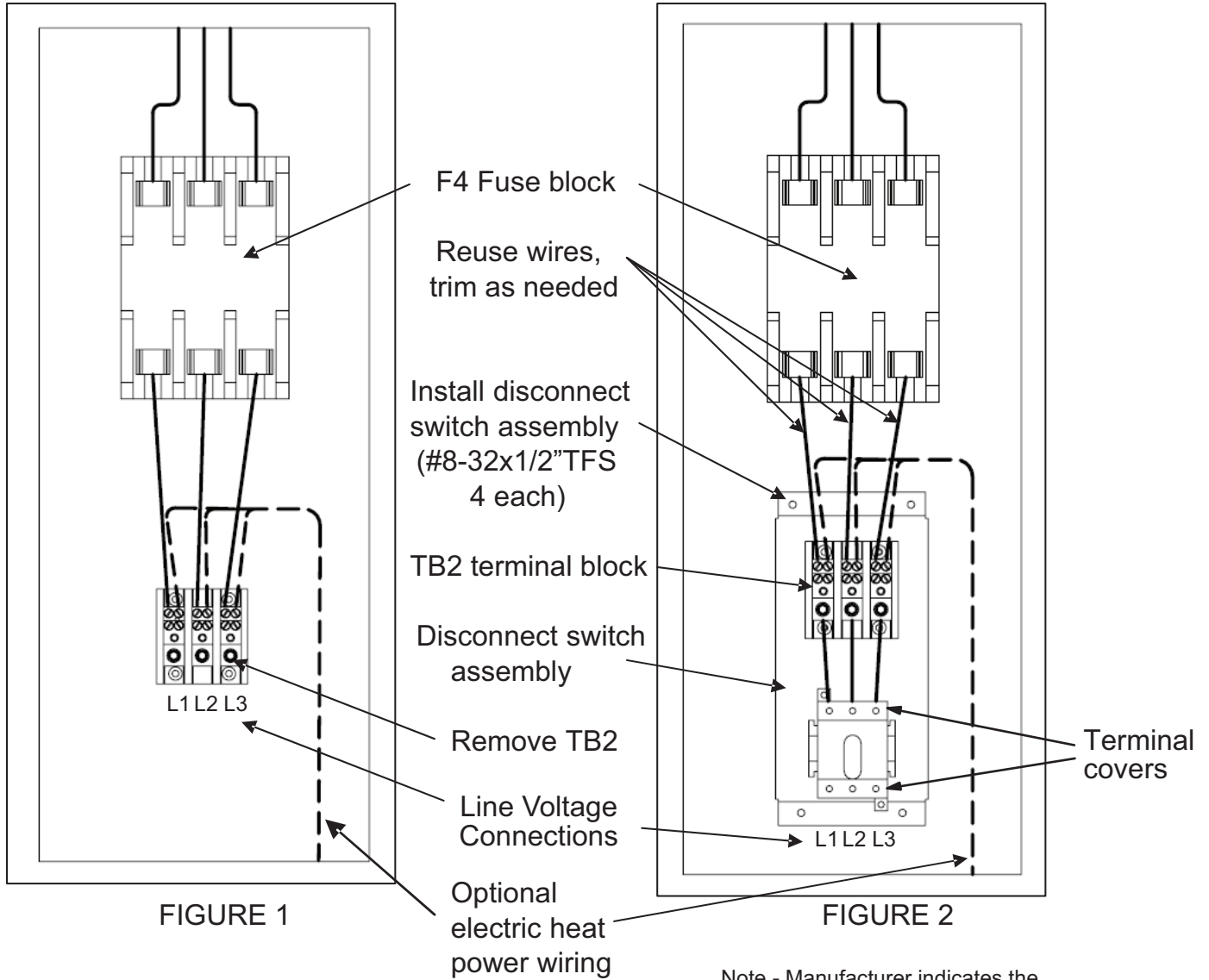

**LC/LH/KC/KH Units:**

**Disconnect box  
from factory**

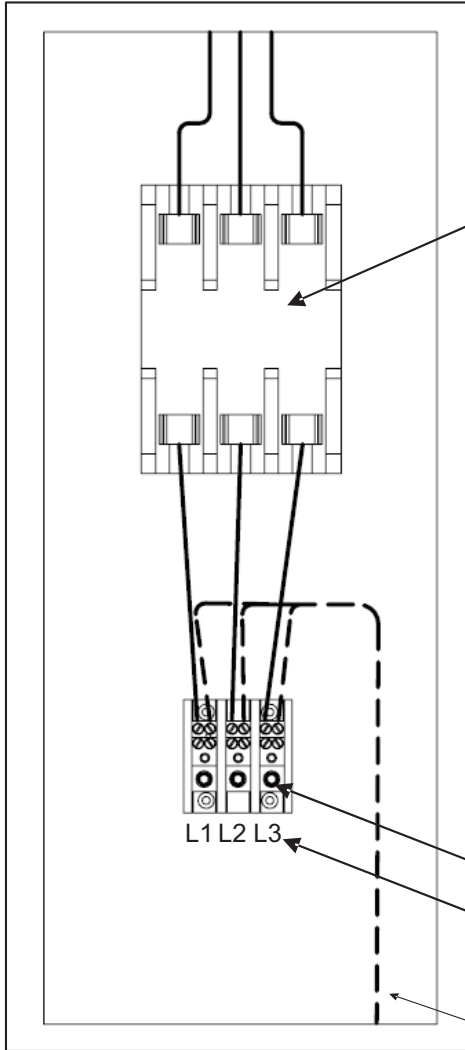

**FIGURE 3**

**Disconnect box  
with field installed  
150 Amp, 250 Amp disconnect switch**

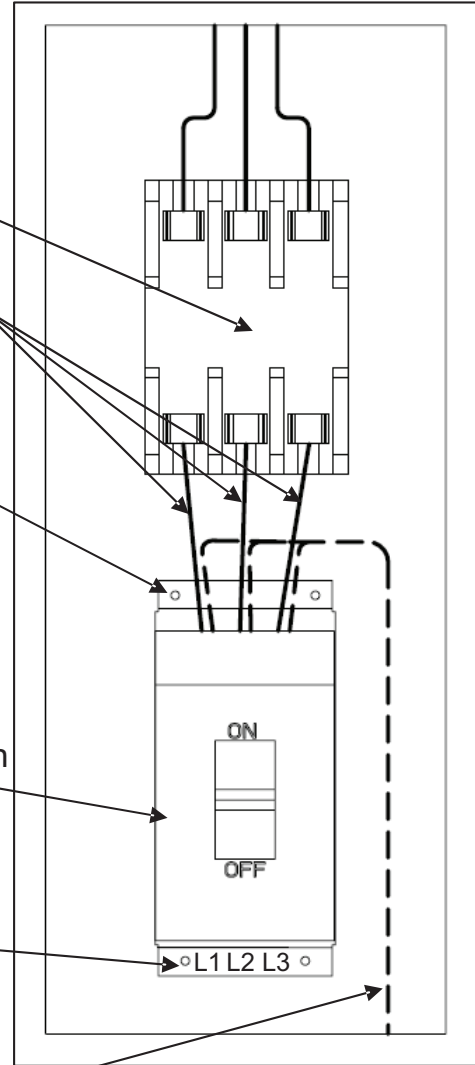

**FIGURE 4**

F4 Fuse block

Reuse wires,  
trim as needed

Install disconnect  
switch assembly  
(#8-32x1/2" TFS  
4 each)

Disconnect switch  
assembly

Remove TB2

Line Voltage  
Connections

Optional  
electric heat  
power wiring

**LG/LD Units:**

**Disconnect box  
from factory**

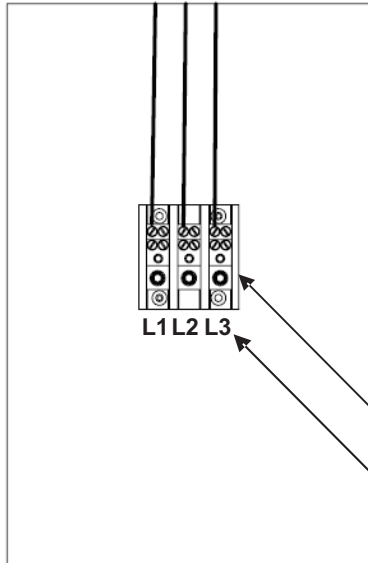

**FIGURE 5**

**Disconnect box  
with field installed  
80 Amp disconnect switch**

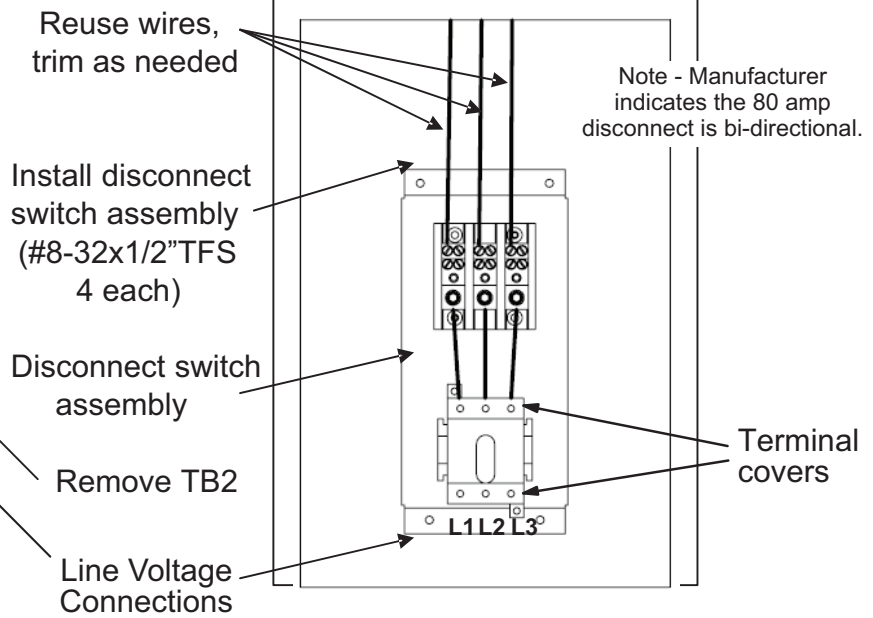

**FIGURE 6**

**Disconnect box  
with field installed  
150 Amp, 250 Amp disconnect switch**

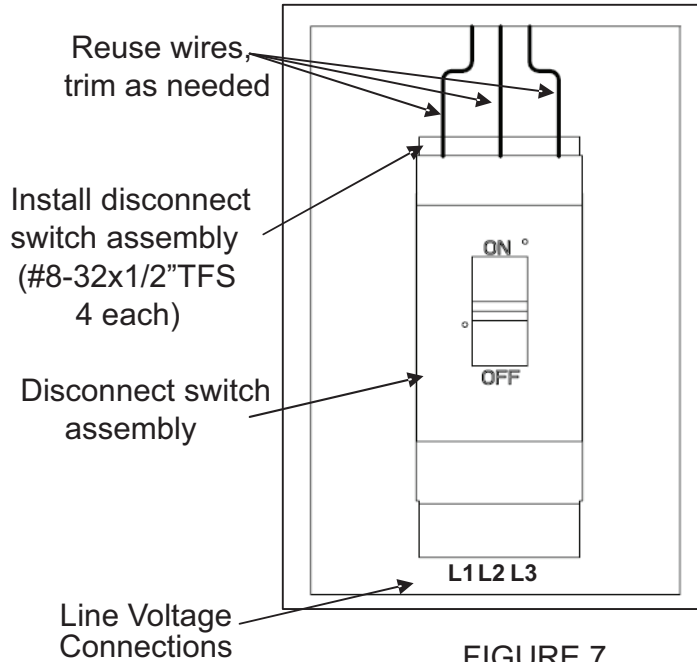

**FIGURE 7**

**On KG/LGX Units:**

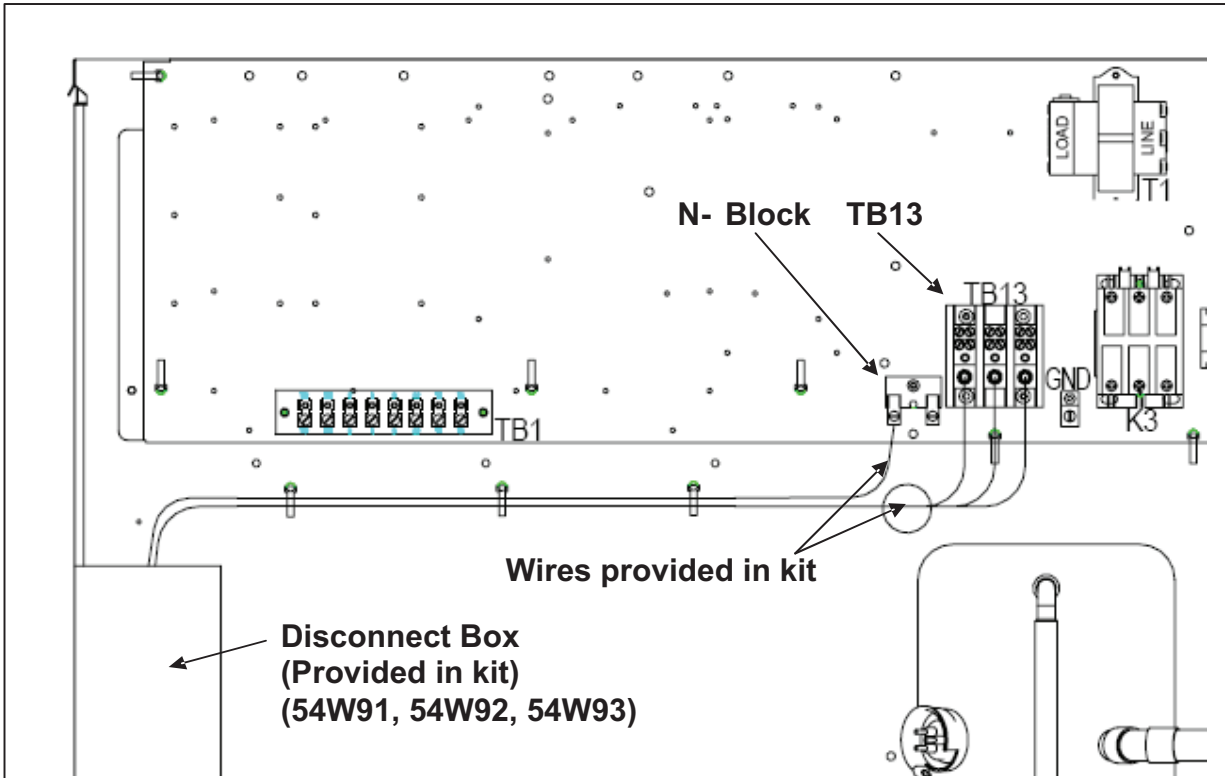

FIGURE 8

**Disconnect box  
with field installed  
80 Amp disconnect switch**

**Disconnect box  
with field installed  
150 Amp, 250 Amp disconnect switch**

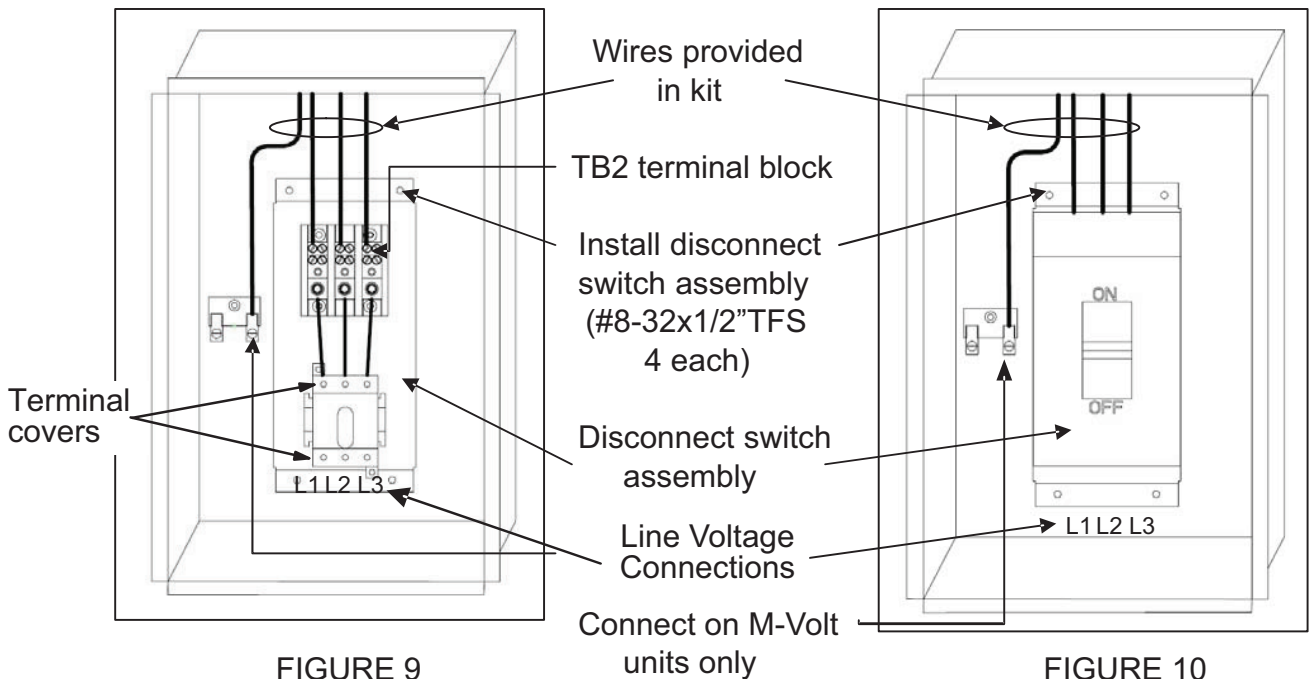

FIGURE 9

FIGURE 10

Note - Manufacturer indicates the 80 amp disconnect is bi-directional.

## Wiring

Make wiring connections as shown in table 2 and on unit diagram. Refer to local codes. Use the following figures to make wiring connections:

### 80A Disconnects

Install plastic terminal covers on the disconnect switch after wiring connections are completed.

TABLE 2

Unit	Disconnect (Amps)	Figure
LC/LH/KC/KH	80	11
	150, 250	12
LG/LD	80	13
	150, 250	14
KG/LGX	80, 150, 250	15

## LC/LH/KC/KH – 80AMP DISCONNECT

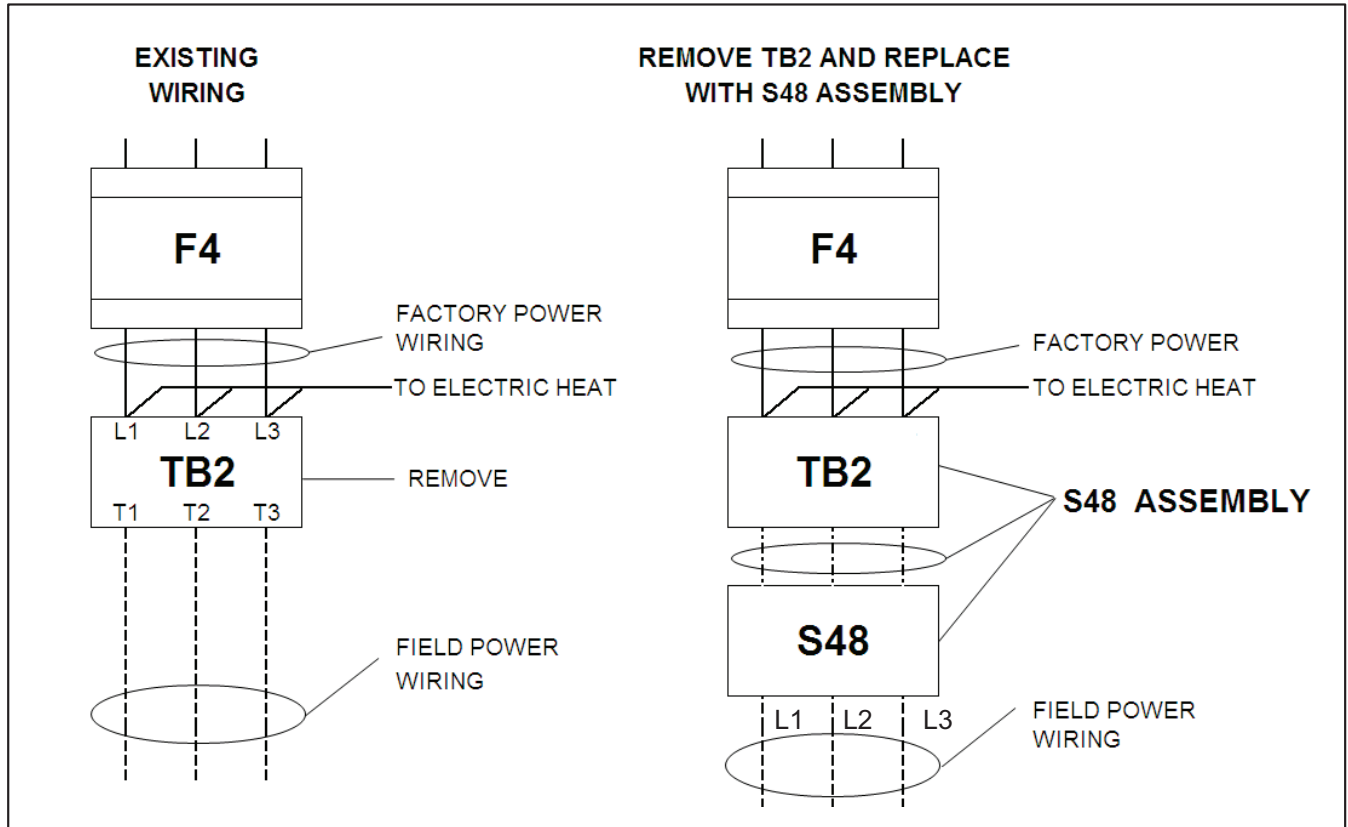

FIGURE 11

Note - Manufacturer indicates the 80 amp disconnect is bi-directional.

# LC/LH/KC/KH – 150AMP, 250AMP DISCONNECT

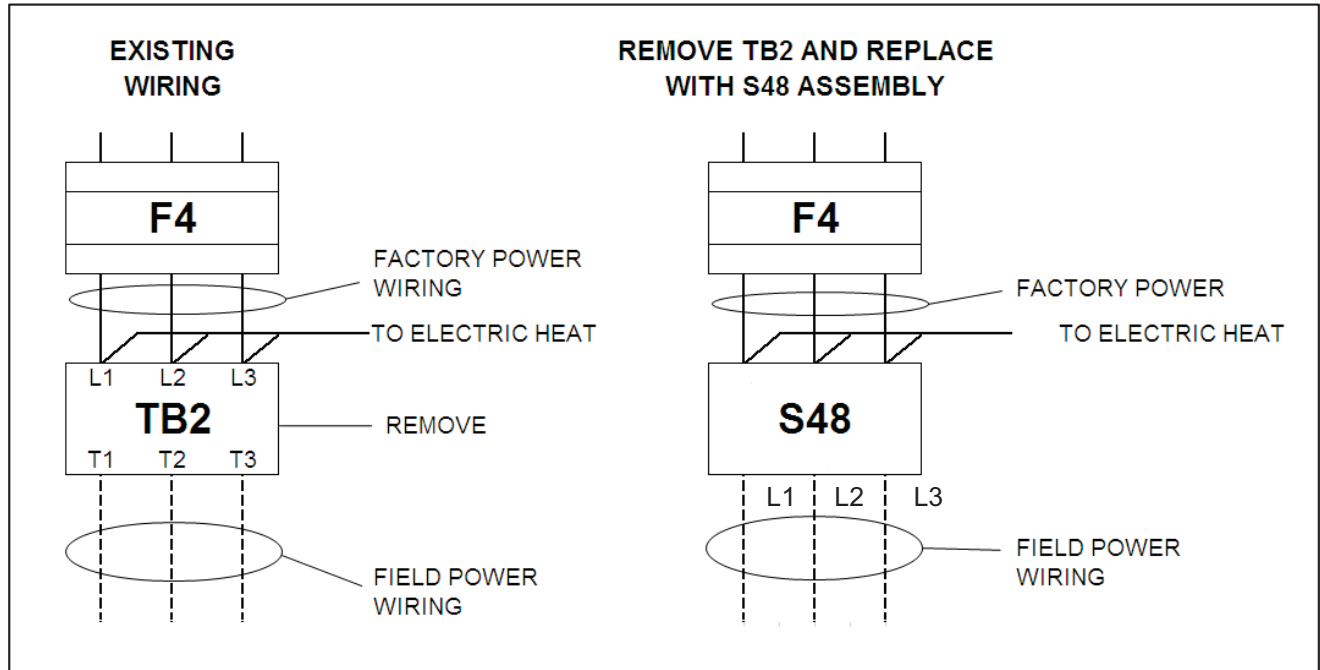

FIGURE 12

# LG/LD – 80AMP DISCONNECT

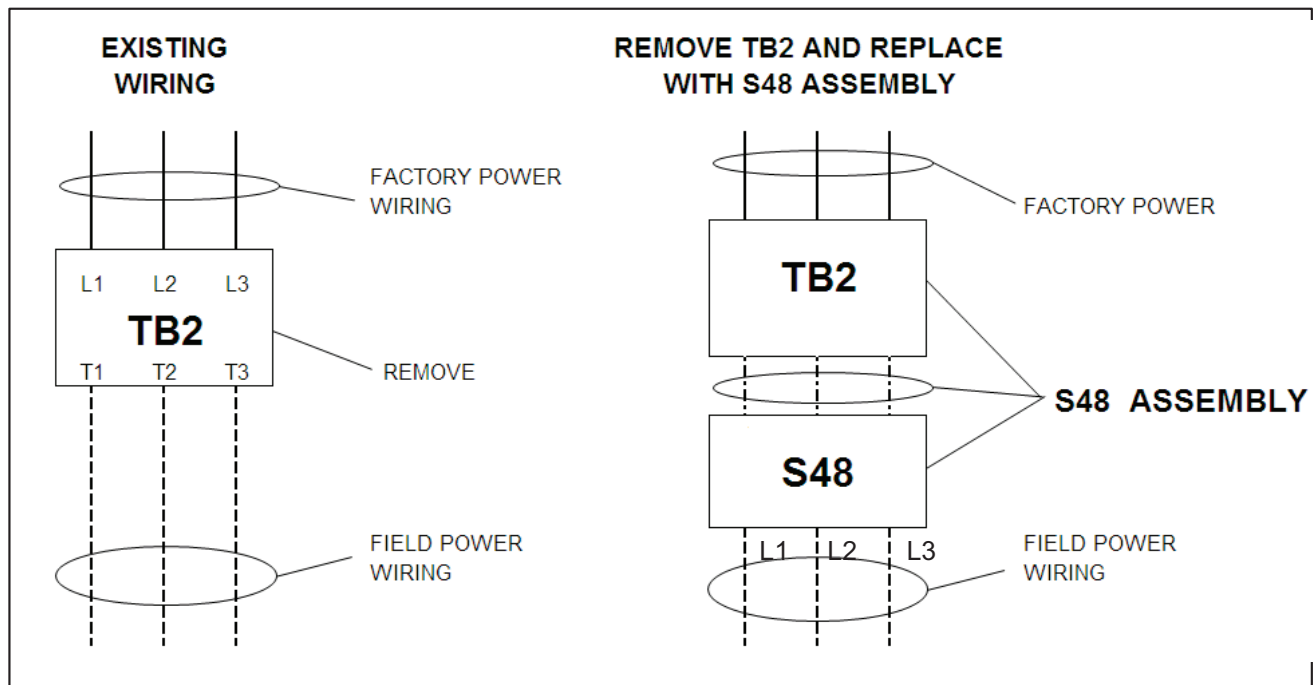

FIGURE 13

Note - Manufacturer indicates the 80 amp disconnect is bi-directional.

## LG/LD – 150 & 250 AMP DISCONNECT

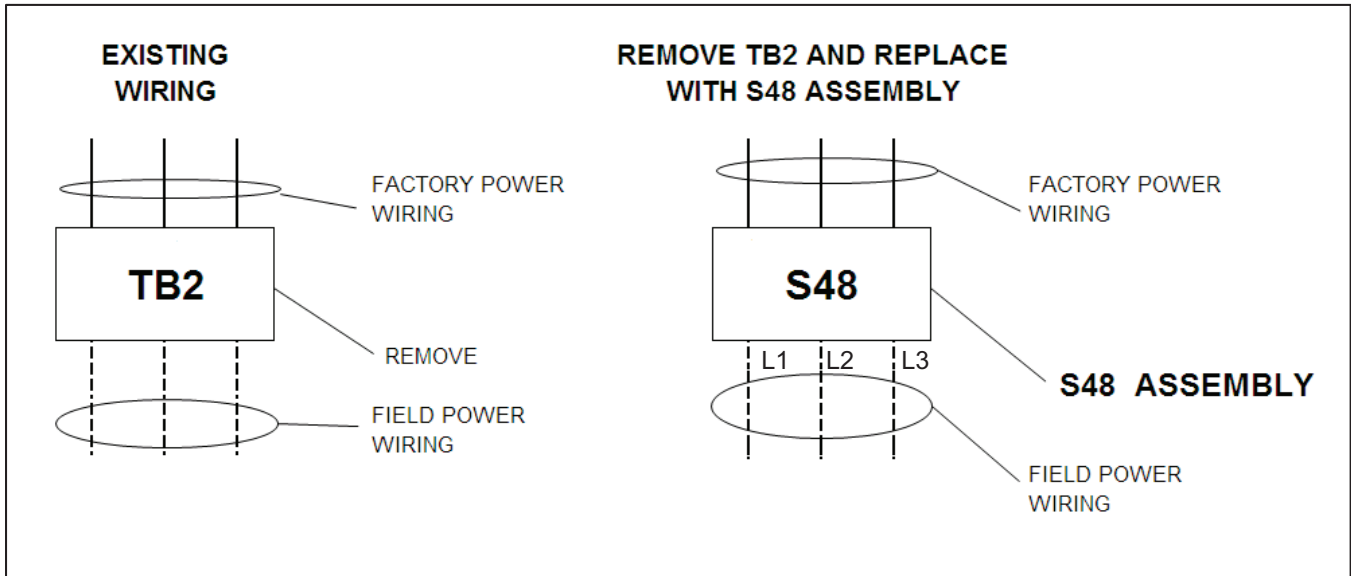

FIGURE 14

## KG/LGX – 80AMP, 150AMP, 250 AMP DISCONNECT

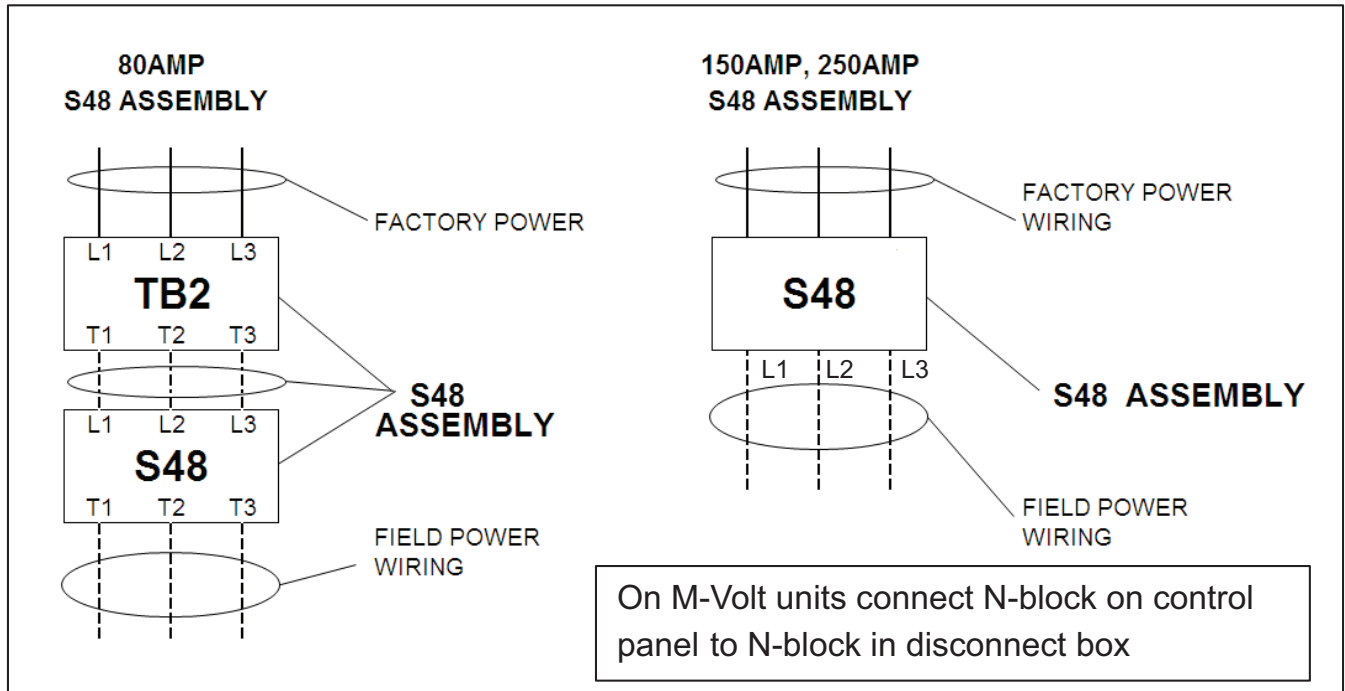

FIGURE 15

Note - Manufacturer indicates the 80 amp disconnect is bi-directional.