

# LCX

## XION™ ROOFTOP UNITS

Standard Efficiency | Lennox® CORE Lite Controller | Environ™ Coil | **R-454B** | 60Hz



### COMMERCIAL PRODUCT SPECIFICATIONS (EHB)

15 to 25 Tons

Net Cooling Capacity – 172,000 to 270,000 Btuh

Optional Electric Heat - 15 to 90 kW



### MODEL NUMBER IDENTIFICATION

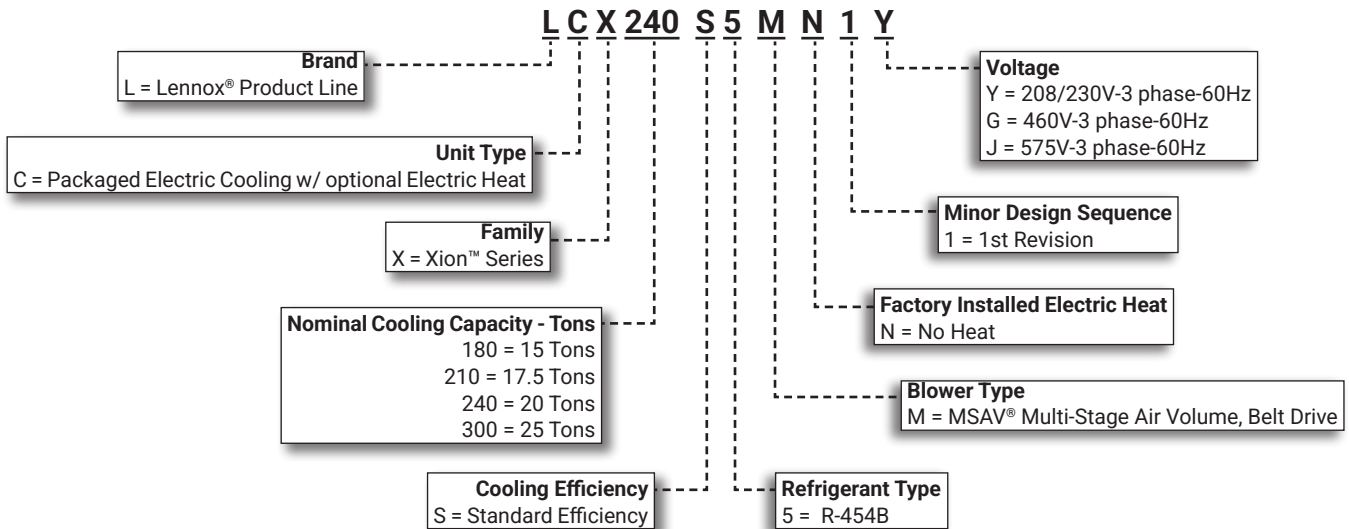

## FEATURE HIGHLIGHTS

Xion™ rooftop units are engineered with the right technologies and options to meet standard efficiency requirements while delivering reliable performance and year-round comfort.

1. Scroll Compressors
2. Thermal Expansion Valves
3. Filter/Driers
4. Environ™ Coil System
5. Outdoor Coil Fan Motors
6. Cabinet Construction
7. MSAV® Multi-Stage Air Volume Blower
8. Disconnect Switch (option)
9. Electric Heat (option)
10. Air Filters
11. Lennox® CORE Lite Control System
12. Economizer (option)
13. Downflow Barometric Relief Dampers (option)
14. Power Exhaust Fans (option)

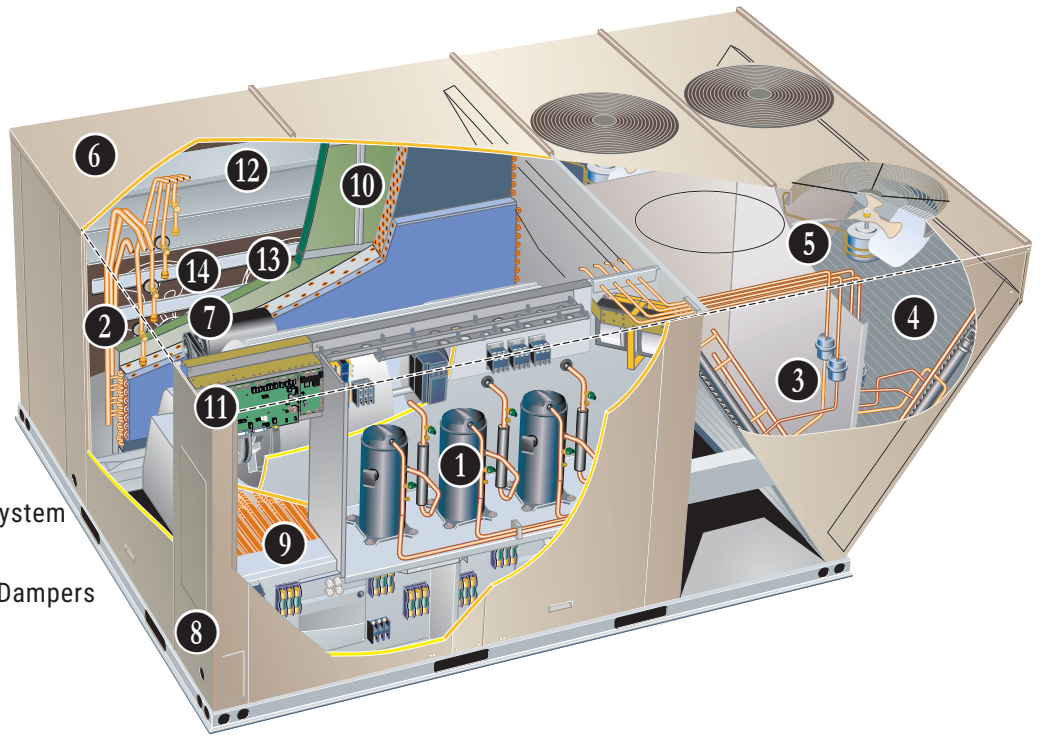

## CONTENTS

Approvals And Warranty . . . . .	3
Blower Data . . . . .	28
Dimensions - Unit . . . . .	39
- LCX180   LCX210 . . . . .	39
- LCX240 . . . . .	40
- LCX300 . . . . .	41
- Optional Accessories . . . . .	42
Electrical Accessories - Disconnects . . . . .	35
Electrical/Electric Heat Data . . . . .	31
- 15 Ton . . . . .	31
- 17.5 Ton . . . . .	32
- 20 Ton . . . . .	33
- 25 Ton . . . . .	34
Electric Heat Capacities . . . . .	37
Features And Benefits . . . . .	3
Humiditrol® Dehumidification System Option . . . . .	12
Humiditrol® Dehumidification System Ratings . . . . .	26
Model Number Identification . . . . .	1
Optional Conventional Temperature Control Systems . . . . .	14
Options / Accessories . . . . .	19
Outdoor Sound Data . . . . .	37
Ratings . . . . .	24
Sequence Of Operation . . . . .	16
Specifications . . . . .	23
Unit Clearances . . . . .	37
Weight Data . . . . .	38

## APPROVALS AND WARRANTY

### APPROVALS

- AHRI Standard 340/360-2023 certified
- ETL and CSA listed
- Unit and components are ETL, NEC, and CEC bonded for grounding to meet safety standards for servicing
- All models are ASHRAE 90.1 energy efficiency compliant and meet or exceed requirements of Section 6.8
- All models meet DOE 2023 energy efficiency standards and UL 60335-2-40 Refrigerant Detector Requirements
- All models have HCAI (formerly OSHPD) OSP and Special Seismic Certification ([Number: OSP-0596](#)), and meet 2021 International Building Code (IBC), 2022 California Building Code (CBC) ASCE 7, and ICC-ES AC156
- All models meet California Code of Regulations, Title 24 and ASHRAE 90.1 Section 6.4.3.10 requirements for staged airflow
- ISO 9001 Registered Manufacturing Quality System

### WARRANTY

- Compressors - Limited five years
- Environ™ Coil System - Limited three years
- Lennox® CORE Lite Unit Controller - Limited three years
- Variable-Frequency Drive (VFD)- Limited five years
- High Performance Economizers (optional) - Limited five years
- All other covered components - Limited one year

## FEATURES AND BENEFITS

### COOLING SYSTEM

- Designed to maximize sensible and latent cooling performance at design conditions
- System can operate from 45°F to 125°F without any additional controls

#### R-454B Refrigerant

- Low GWP (Global Warming Potential)
- Zero ODP (Ozone Depletion Potential)
- Low Toxicity/Lower Flammability - A2L
- Unit is factory pre-charged

#### 1 Scroll Compressors

- Scroll compressors on all models for high performance, reliability, and quiet operation
- Resiliently mounted on rubber grommets for quiet operation

#### Compressor Crankcase Heaters

- Protects against refrigerant migration that can occur during low ambient operation or during extended off cycles

#### 2 Thermal Expansion Valves

- Ensures optimal performance throughout the application range
- Removable element head

#### 3 Filter/Driers

- High capacity filter/drier protects the system from dirt and moisture

#### High Pressure Switches

- Protects the compressor from overload conditions such as dirty condenser coils, blocked refrigerant flow or loss of outdoor fan operation

#### Low Pressure Switches

- Protects the compressors from low pressure conditions such as low refrigerant charge or low/no airflow

#### Indoor Coil Freeze Protection

- Protects the evaporator coil from damaging ice build-up due to conditions such as low/no airflow or low refrigerant charge

#### 4 Condenser Coil - Environ™ Coil System

- Lightweight, all aluminum brazed fin construction
- Constructed of three components
  - A flat extrusion tube
  - Fins in-between the flat extrusion tube
  - Two refrigerant manifolds

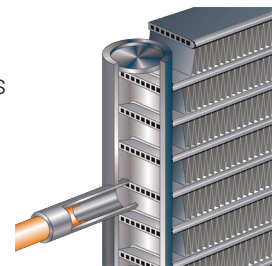

#### Environ™ Coil System Features:

- Improved heat transfer performance due to high primary surface area (flat tubes) versus secondary surface (fins)
- Smaller internal volume (reduced refrigerant charge)
- High durability
- All aluminum construction
- Fewer brazed joints
- Compact design
- Reduced unit weight
- Easy maintenance/cleaning
- Mounting brackets with rubber inserts secure coil to unit providing vibration dampening and corrosion protection
- Angled cabinet design protects coil from damage

## FEATURES AND BENEFITS

### COOLING SYSTEM (continued)

#### Evaporator Coil

- Copper tube construction
- Enhanced rippled-edge aluminum fins
- Flared shoulder tubing connections
- Silver soldered construction
- Factory leak tested
- Cross-row circuiting with rifled tubing

#### Antimicrobial Condensate Drain Pan

- Composite pan, sloped to meet drainage requirements of ASHRAE 62.1
- Antimicrobial additive resists growth of mold and mildew on drain pan, which improves indoor air quality and reduces drain line blockage
- Side or bottom drain connections

### 5 Outdoor Coil Fan Motors

- Thermal overload protected
- Totally enclosed
- Permanently lubricated ball bearings
- Shaft up
- Wire basket mount

#### Outdoor Coil Fans

- PVC coated fan guard furnished

### Required Selections

#### Cooling Capacity

- Specify nominal cooling capacity

### Options/Accessories

#### Field Installed

#### Condensate Drain Trap

- Available in copper or PVC

#### Drain Pan Overflow Switch

- Monitors condensate level in drain pan, shuts down unit if drain becomes clogged

#### Low Ambient Controls (0°F)

- Units operate satisfactorily down to 45°F outdoor air temperature without any additional controls
- Allows unit operation down to 0°F without evaporator coil icing
- Head pressure speed control reduces outdoor fan operation during low ambient conditions unit head pressure rises to the setpoint
- Pressure transducers are mounted on the liquid lines
- Liquid line pressure switches and temperature switches are provided for field installation
- Wiring harnesses are furnished for simple plug-in wiring to fans and controller

### LOW GWP REFRIGERANT DETECTION SYSTEM (RDS)

- Complies with UL 60335-2-40 approved standard
- Required for all systems using R-454B refrigerant
- Factory installed on all units
- Consists of a refrigerant detection sensor(s) and a mitigation control
- Ensures safe operation for systems equipped with R-454B refrigerant
- Sensor(s) monitors indoor coil area for R-454B refrigerant
- If R-454B refrigerant is detected the refrigerant detection system will prevent compressor and heating operation until R-454B refrigerant is no longer detected
- Refrigeration detection system energizes blower if any R-454B refrigerant is detected to mitigate any concentrations of refrigerant from the unit and the system

## FEATURES AND BENEFITS

### **CABINET**

#### **6** Construction

- Heavy-gauge steel panels
- Full perimeter heavy-gauge galvanized steel base rail
- Base rails have rigging holes
- Three sides of the base rail have forklift slots
- Raised edges around duct and power entry openings in the bottom of the unit for water protection

#### Airflow Choice

- Units are shipped in downflow (vertical) return air flow configuration

**NOTE** - Units can be field converted to horizontal air flow with optional Horizontal Return Air Panel Kit and Horizontal Roof Curb.

#### Power Entry

- Electrical lines can be routed through the unit base or through horizontal access knock-outs

#### Exterior Panels

- Constructed of heavy-gauge, galvanized steel
- Textured pre-paint with polyurethane finish
- Cyclic salt fog and UV exposure up to 1,680 hours per ASTM D5894

#### Insulation

- Fully insulated with non-hygroscopic fiberglass insulation (conditioned areas)
- Unit base is fully insulated
- Base insulation serves as an air seal to the roof curb, eliminating the need to add a seal during installation

#### Access Panels

- Economizer/Filter section
- Heating/Blower section
- Compressor/Controls section

### Options/Accessories

#### **Factory Installed**

##### Hinged Access Panels

- Tool-less access
- Filter section
- Heating/Blower section
- Compressor/Controls section
- Panel seals and quarter-turn latching handles provide a tight air and water seal

#### **Factory or Field Installed**

##### Combination Coil/Hail Guards

- Heavy gauge steel frame
- Painted to match cabinet
- Expanded metal mesh protects outdoor coil

#### **Field Installed**

##### Horizontal Return Air Panel Kit

- Required for horizontal applications with Horizontal Roof Curb
- Contains panel with return air opening for field replacement of existing unit panel and panel to cover bottom return air opening in unit
- See dimension drawings

#### **Burglar Bars**

- Heavy gauge galvanized frame
- Fully welded
- 3/4 in. bar meets ASTM specification
- Frame meets ASTM A446, A525, A526 and A527 specification
- Burglar bars designed to fit ductwork

## FEATURES AND BENEFITS

### **BLOWER**

A wide selection of supply air blower options are available to meet a variety of airflow requirements

#### **Motor**

- Overload protected
- Ball bearings

#### **7 Supply Air Blower**

- Forward curved blades
- Double inlet
- Blower wheel is statically and dynamically balanced
- Ball bearings
- Adjustable pulley (allows speed change)
- Blower assembly slides out of unit for servicing
- Grease fittings furnished

#### **Blower Proving Switch**

- Monitors blower operation, shuts down unit if blower fails

#### **MSAV® Multi-Stage Air Volume Operation**

- MSAV® Multi-Stage Air Volume stages the amount of airflow according to compressor stages, heating demand, ventilation demand or smoke alarm
- Units utilize a Variable Frequency Drive (VFD) to stage the supply air blower airflow
- VFD alters the frequency and voltage of the power supply to the blower to control blower speed
- The amount of airflow for each stage can be set according to a parameter in the Lennox® CORE Unit Controller
- Unit is shipped from the factory we preset airflow
- VFD has an operational range of -40 to 125°F outdoor air ambient temperature
- Lower operating costs are obtained when the blower is operated on lower speeds.

**NOTE** - Units equipped a Variable Frequency Drive (VFD) are designed to operate on balanced, three-phase power. Operating units on unbalanced three-phase power will reduce the reliability of all electrical components in the unit. Unbalanced power is a result of the power delivery system supplied by the local utility company. Factory-installed inverters are sized to drive blower motors with an equivalent current rating using balanced three-phase power. If unbalanced three-phase power is supplied, the installer must replace the existing factory-installed inverter with an inverter that has a higher current rating to allow for the imbalance. Refer to the installation instructions for additional information and replacement information

#### **Ordering Information**

- Specify motor horsepower and drive kit number when base unit is ordered

### Options/Accessories

#### **Field Installed**

##### **Blower Belt Auto-Tensioner**

- Provides proper tension to belt drive blower belt without the need for regular adjustments
- Maintains airflow and proper performance

##### **VFD Automatic Bypass Kit**

- Bypass Kit can be used to automatically bypass the VFD and operate the unit in single speed (CAV) blower mode if the inverter needs to be serviced or replaced
- VFD Automatic Bypass Control must be enabled by Config ID on the unit controller

## FEATURES AND BENEFITS

### ELECTRICAL

#### SmartWire™ System

- Keyed and color-coded wiring connectors prevent miswiring
- Wire coloring scheme is standardized across all models
- Each connection is intuitively labeled to make troubleshooting and servicing quick and easy

#### Electrical Plugs

- Positive connection electrical plugs connect common accessories or maintenance parts for easy removal or installation

#### Phase/Voltage Detection

- Monitors power supply to ensure correct phase at unit start-up
- If phase is incorrect, the unit will not state and an alarm code reports to the unit controller
- Prevents unit start-up if the unit is in the incorrect phase; unit start-ups in the wrong phase could lead to issues such as compressors functioning in reverse
- Monitors power supply voltage to ensure proper voltage
- If voltage is not correct (over/under voltage conditions) the unit will not start and an alarm code reports to the unit controller

### Required Selections

#### Voltage Choice

- Specify when ordering base unit

### Options/Accessories

#### Factory or Field Installed

#### 8 Disconnect Switch

- Accessible from outside of unit
- Spring loaded weatherproof cover furnished

#### GFI Service Outlets (2)

- 115V ground fault circuit interrupter (GFCI) type options:
  - Factory installed, non-powered, field wired
  - Field installed, non-powered, field wired

#### Field Installed

#### 9 Electric Heat

- Helix wound nichrome elements
- Individual element limit controls
- Wiring harness
- Unit fuse block
- See Options / Accessories tables for ordering information

#### GFI Weatherproof Cover

- Single-gang cover
- Heavy-duty UV-resistant polycarbonate case construction
- Hinged base cover with gasket

### INDOOR AIR QUALITY

#### 10 Air Filters

- Disposable 2 inch MERV 4 filters furnished as standard

### Options/Accessories

#### Field Installed

#### Healthy Climate® High Efficiency Air Filters

- Disposable MERV 8, MERV 13, or MERV 16 (Minimum Efficiency Reporting Value based on ASHRAE 52.2) efficiency
- 2 inch pleated filters

#### Healthy Climate® UVC Germicidal Lamps



- Germicidal lamps emit ultra-violet (UV-C) energy, which has been proven to be effective in reducing microbes such as viruses, bacteria, yeasts, and molds
- UV-C energy greatly reduces the growth and proliferation of mold and other bioaerosols (bacteria and viruses) on illuminated surfaces (particularly coil and drain pan)
- Destroys the organism or controls its ability to reproduce
- Field installed in the blower/evaporator coil section
- Magnetic safety interlock terminates power when access panels are removed
- All necessary hardware for installation is included
- Lamps operate on 110/230V-1ph power supply
- **NOTE** - Step-down transformer may be ordered separately for 460V and 575V units.
- Approved by ETL

#### Needlepoint Bipolar Ionization (NPBI) Kit

- NPBI technology has been shown to effectively reduce harmful pathogens, pollutants, and odors
- Brush-type ionizer introduces a high concentration of both positive and negative ions into the air stream
- These bipolar ions are then dispersed into the occupied space through the duct system proactively reducing the airborne contaminants
- Ions travel within the building air stream and attach to particles, pathogens, and gas molecules, making them larger and easier to capture in the filtration system
- UL 2998 certified for zero ozone emission

#### Indoor Air Quality (CO<sub>2</sub>) Sensors

- Monitors CO<sub>2</sub> levels
- Reports to the Lennox® CORE Lite Unit Controller, which adjusts economizer dampers as needed

#### Replacement Filter Media Kit With Frame

- Replaces existing pleated filter media
- Includes washable metal mesh screen and metal frame with clip for holding replaceable non-pleated filter

## CONTROL SYSTEM

### LENNOX® CORE LITE CONTROL SYSTEM

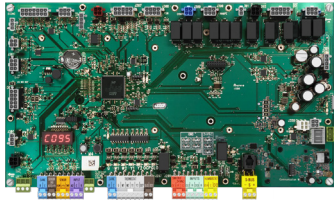

- 11** The Lennox® CORE Lite Control System is designed to accelerate equipment install and service. Standard with all Xion™ rooftop units, control system integrates key technologies that lower installation costs, drive system efficiency, and protect your investments.

The Lennox® CORE Lite Unit Controller is a microprocessor-based controller that provides flexible control of all unit functions.

#### CORE Mobile Service App

- Guided Setup with progress indicators, detailed help, and exportable summaries to manage simple, trouble-free setup, reducing commissioning times
- Enhanced Test Functionality provides real-time sensor readings, trending, and reports that enable easy troubleshooting
- Ability to set and configure parameters of the CORE Control System to manage sequence of operation
- Economizer test function ensures economizer is operating correctly



#### Additional Features:

- Built-In 7-Segment Display shows Unit Status and active alarms for easy troubleshooting
- Buttons for test and clearing delays
- SmartWire™ System with keyed and removable screw terminals ensure correct field wiring
- Profile setup copies key settings between units with the same configuration to reduce setup time
- USB port allows a technician to download and transfer unit information to help verify service was performed
- USB software updates on the Lennox® CORE Lite Unit Controller enhance functionality without the need to change components

#### Configurable Built-In Functions

- Up to three distinct Cooling Airflows in Thermostat Mode
- Programmable independent heating, ventilation and cooling blower speeds
- Economizer Control Options (See Economizer / Exhaust Air / Outdoor Air sections)
- Exhaust Fan Control Modes for fresh air damper position
- Configurable Morning Warm-up
- Night Setback Mode
- Demand Control Ventilation
- Humiditrol® Operation

#### Component Protection / Unit Safeguards:

- Compressor Time-Off Delay
- Adjustable Blower On/Off Delay
- Return Air Temperature Limit Control
- Safety Switch Input allows Controller to respond to a external safety switch trip
- Service Relay Output
- Thermostat Bounce Delay
- Smoke Alarm Mode has four choices (unit off, positive pressure, negative pressure, purge)
- "Strike Three" Protection
- Gas Valve Time Delay Between First and Second Stage
- Minimum Compressor Run Time

#### Control Methods / Interfaces:

- DDC and 24V Thermostat
- BACnet MS/TP (Field Option)
- Lennox S-BUS
- Zone Temperature Sensor Input
- Dehumidistat and Humidity Sensor Inputs
- Indoor Air Quality Inputs (2)
- Built-in Control Parameter Defaults
- Permanent Diagnostic Code Storage
- Field Adjustable Control Parameters (Over 200 settings)
- Multiple Configurable Digital Inputs
- LED Indicators

**NOTE** - Lennox® CORE Control System features vary with the type of rooftop unit in which the control is installed.

## CONTROL SYSTEM

### **LENNOX® CORE LITE CONTROL SYSTEM (continued)**

#### Controls Options

##### **Field Installed**

##### **Dirty Filter Switch**

- Senses static pressure increase and issues alarm if necessary

##### **Smoke Detector**

- Photoelectric type
- Installed in supply air section, return air section or both sections
- Available with power board and single sensor (supply or return) or power board and two sensors (supply and return)
- Power board located in unit control compartment

## OPTIONS / ACCESSORIES

### **ECONOMIZER**

- Economizer operation is set and controlled by the Lennox® CORE Lite Unit Controller
- Simple plug-in connections from Economizer to unit controller for easy installation
- All Xion™ rooftop units are equipped with factory installed CEC Title 24 approved sensors for outside, return and discharge air temperature monitoring

**NOTE** - Optional sensors may be used instead of unit sensors to determine whether outdoor air is suitable for free cooling. See Options/Accessories table.

#### **Factory or Field Installed**

##### **12 High Performance Economizer**

- Approved for California Title 24 building standards
- Low leakage dampers are Air Movement and Control Association International (AMCA) Class 1A Certified - Maximum 3 CFM per sq. ft. leakage at 1 in. w.g.
- ASHRAE 90.1 and IECC compliant
- Downflow or Horizontal with Outdoor Air Hood
- Outdoor Air Hood with mist elimination is included when Economizer is factory installed and is furnished with Economizer when ordered for field installation

**NOTE** - Downflow or horizontal economizer applications require optional Downflow or Horizontal Barometric Relief Dampers with Exhaust Hood.

- Linked damper action
- High torque 24-volt fully-modulating spring return damper motor
- Return air and outdoor air dampers
- Plug-in connections to unit

**NOTE** - High Performance Economizers are not approved for use with enthalpy controls in Title 24 applications.

**NOTE** - The Free Cooling setpoint for Title 24 applications must be set based on the Climate Zone where the system is installed. See Section 140.4 "Prescriptive Requirements for Space Conditioning Systems" of the California Energy Commission's 2019 Building Energy Efficiency Standards.

**NOTE** - Refer to Installation Instructions for complete setup information.

#### **Differential Sensible Control**

- Factory setting
- Uses outdoor air and return air sensors that are furnished with the unit
- The Lennox® CORE Lite unit controller compares outdoor air temperature with return air
- When the outdoor air is below the configured setpoint and cooler than return air, the controller activates the Economizer

### ECONOMIZER (continued)

#### Factory or Field Installed

**NOTE** - Differential Sensible Control can be configured in the field to provide Offset Differential Sensible Control or Single Sensible Control.

**NOTE** - In Offset Differential Sensible Control mode, the Economizer is enabled if the temperature differential (offset) between outdoor air and return air reaches the configured setpoint. In Single Sensible Control mode, the Economizer is enabled when outdoor air temperature falls below the configured setpoint.

#### Single Enthalpy Control (Not for Title 24)

- Outdoor air enthalpy sensor enables Economizer if the outdoor enthalpy is less than the setpoint of the control

#### Field Installed

##### Differential Enthalpy Control (Not for Title 24)

- Order two Single Enthalpy Controls
- One is field installed in the return air section
- One is installed in the outdoor air section
- Allows the Economizer control to select between outdoor air or return air, whichever has lower enthalpy

### EXHAUST

#### Factory or Field Installed

- 13** **Downflow Barometric Relief Dampers**
- Allow relief of excess air
  - Aluminum blade dampers prevent blow back and outdoor air infiltration during off cycle
  - Exhaust hood is factory installed when dampers are factory installed with Economizer
  - Exhaust hood is furnished with dampers when ordered for field installation
  - Bird screen furnished

#### Field Installed

- 14** **Power Exhaust Fans**
- Install internal to unit for downflow applications only with Economizer option
  - Provides exhaust air pressure relief
  - Interlocked to run when supply air blower is operating
  - Fans run when outdoor air dampers are 50% open (adjustable)
  - Motor is overload protected
  - Dual propeller type fans are 20 in. diameter
  - Five blades
  - Two 1/3 HP motors
  - SCCR rated

**NOTE** - Requires Economizer with furnished Outdoor Air Hood and Downflow Barometric Relief Dampers.

**NOTE** - All models are equipped with 2-stage power exhaust fans. Power exhaust operates in 1st stage (one fan) up to 70% of supply air blower speed. Both exhaust fans operate in 2nd stage when supply air blower speed is above 70% (adjustable) of full speed.

#### Horizontal Barometric Relief Dampers

- For use when unit is configured for horizontal applications requiring an Economizer
- Allows relief of excess air
- Aluminum blade dampers prevent blow back and outdoor air infiltration during off cycle
- Field installed in return air duct
- Bird screen and hood furnished

## OPTIONS / ACCESSORIES

### **OUTDOOR AIR**

#### **Field Installed**

##### **Motorized Outdoor Air Damper**

- Linked mechanical dampers
- Fully modulating spring return damper motor with plug-in connection
- 0 to 25% (fixed) outdoor air adjustable
- Installs in unit
- Outdoor air hood with bird screen included

##### **Manual Outdoor Air Damper**

- Adjustable slide damper
- Installed in unit
- Outdoor air hood with bird screen included

### **ROOF CURBS**

#### **Field Installed**

- Nailer strip furnished (downflow only)
- Mates to unit
- US National Roofing Contractors Approved
- Shipped knocked down

#### **Downflow**

##### **Hybrid Roof Curbs**

- Interlocking tabs fasten corners together
- No tools required for assembly
- Can also be fastened together with furnished hardware
- Available in 8, 14, 18, and 24 inch heights

##### **Adjustable Pitch Curb**

- Fully adjustable pitch curbs (3/4 in. per foot in any direction) provide a level platform for rooftop units allowing flexible installations on roofs with uneven or sloped angles
- Interlocking tabs fasten corners together
- No tools required for assembly
- Hardware is furnished to connect upper curb with lower curb
- Available in 14 inch height

### **Horizontal**

- Meet National Roofing Code requirements
- Converts unit from downflow to horizontal (side) air flow
- Return air is on unit
- Supply air is on curb
- See dimension drawings
- Available in 26, 30, 37, and 41 inch heights

**NOTE** - Requires Horizontal Return Air Panel Kit.

**NOTE** - Optional Insulation Kit is available to help prevent sweating.

### **Adaptor Curbs (not shown)**

- Curbs are regionally sourced
- Dimensions vary based upon the source

**NOTE** - Contact your local sales representative for a detailed cut sheet with applicable dimensions.

### **CEILING DIFFUSERS**

#### **Field Installed**

##### **Ceiling Diffusers (Flush or Step-Down)**

- White powder coat finish on diffuser face and grilles
- Insulated UL listed duct liner
- Diffuser box has collars for duct connection
- Step-down diffusers have double deflection blades
- Flush diffusers have fixed blades
- Provisions for suspending
- Internally sealed to prevent recirculation
- Removable return air grille
- Adapts to T-bar ceiling grids or plaster ceilings

##### **Transitions (Supply and Return)**

- Used with diffusers
- Installs in roof curb
- Galvanized steel construction
- Flanges furnished for duct connection to diffusers
- Fully insulated

## HUMIDITROL® DEHUMIDIFICATION SYSTEM OPTION

### **OVERVIEW**

**NOTE** - Humiditrol® Dehumidification System only available for MSAV® Multi-Stage Air Volume models

- Factory installed option designed to control humidity
- Provides dehumidification on demand using ASHRAE 90.1 recommended method for comfort conditioning humidity control
- Unit comes equipped with one row reheat coil, solenoid valve

**NOTE** - A dehumidification demand from a relative humidity sensor, dehumidistat, a DDC controller or building automation system is required to control humidity.

Controls are not furnished and must be ordered extra.

### **BENEFITS**

- Improves indoor air quality
- Helps prevent damage due to high humidity levels
- Improves comfort levels by reducing space humidity levels

### **OPERATION**

#### **No Dehumidification Demand**

- The unit will operate conventionally whenever there is a demand for cooling or heating and no dehumidification demand
- Free cooling is only permitted when there is no demand for dehumidification

#### **Dehumidification Demand Only**

- Reheat operation will initiate on a dehumidification demand and does not require a cooling demand
- Unit will operate in the dehumidification mode until the relative humidity of the conditioned space is below the setpoint
- Reheat coil is sized to provide 68°F to 75°F supply air during reheat operation
- This reduces sensible cooling capacity and extends compressor run time to control humidity when the cooling load is low
- A solenoid valve diverts hot gas from the compressor to the reheat coil
- Cooled and dehumidified air from the evaporator is reheated as it passes through the reheat coil
- De-superheated and partially condensed refrigerant continues to the outdoor condenser coil where condensing is completed
- Unit will continue to operate in this mode until the dehumidification demand is satisfied
- Dehumidification and Cooling Demand (Thermostat/ Room Sensor Application)
- If both a dehumidification and a full cooling load demand occur, the system will operate in cooling mode until the cooling demand is satisfied
- Then the system will energize the dehumidification mode

# HUMIDITROL® DEHUMIDIFICATION SYSTEM OPTION

## REFRIGERANT SCHEMATIC (180, 210 AND 240 MODELS ONLY)

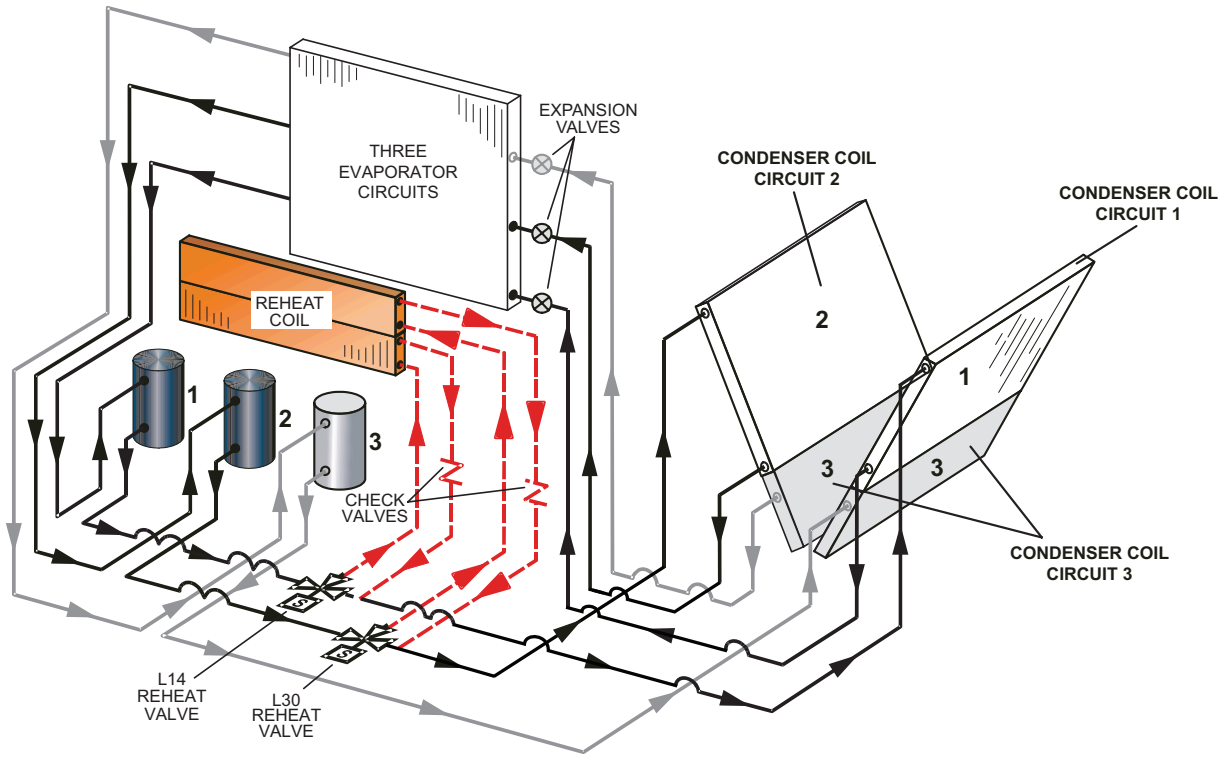

## REFRIGERANT SCHEMATIC (300 MODELS ONLY)

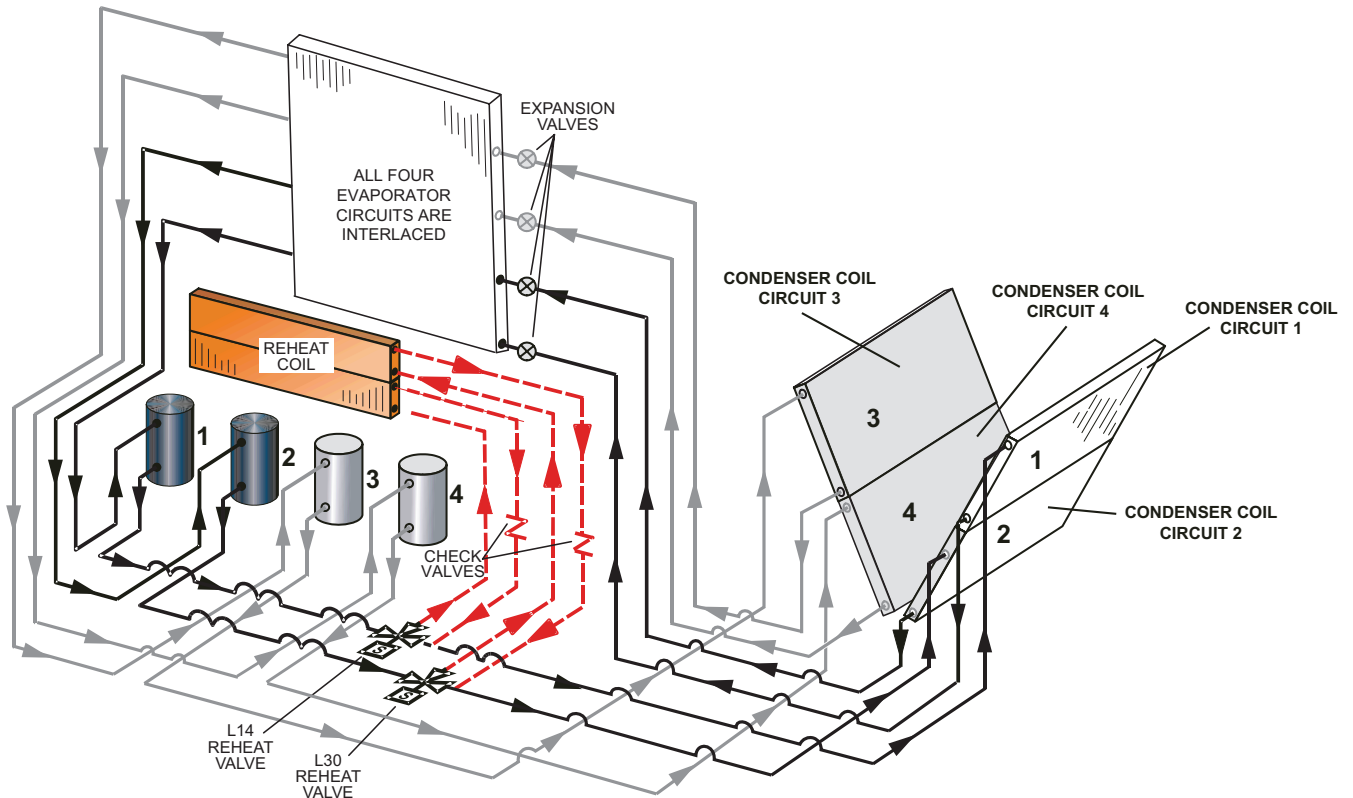

## OPTIONAL CONVENTIONAL TEMPERATURE CONTROL SYSTEMS

### CS8500 Commercial 7-Day Programmable Thermostat

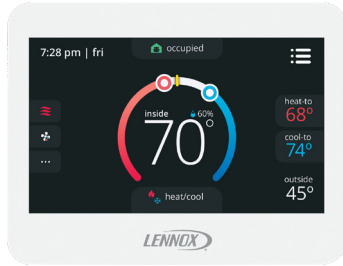

- Fully Communicating Sensor
- Full Color Touchscreen Interface
- Variable Speed System Control (On Compatible Units)
- Up To 4 Heat / 4 Cool
- Built-In Sensors For Temperature, Humidity And Optional CO<sub>2</sub>
- Remote Sensor Options For Occupancy, Temperature
- BACnet Capable Options
- 5-2 or 7-Day Scheduling
- Smooth Setback Recovery
- Heat/Cool Auto-Changeover
- Four-Wire Installation
- FDD, ASHRAE, IECC Compliant

### CS7500 Commercial 7-Day Programmable Thermostat



- Premium Universal Thermostat
- Full Color Touchscreen Interface
- Up To 4 Heat / 3 Cool
- Built-In Sensors For Temperature and Humidity
- Remote Sensors Options For Temperature, Discharge Air, Outdoor Air
- 5-2 or 7-Day Scheduling
- Smooth Setback Recovery
- Heat/Cool Auto-Changeover
- FDD, ASHRAE, IECC Compliant

### CS3000 Commercial 5-2 Day Programmable Thermostat



- Conventional Multi-Stage Thermostat
- Intuitive Display
- Push-Button Operation
- Up To 2 Heat / 2 Cool
- Built-In Temperature Sensor
- Remote Temperature Sensing
- Up to 5-2 Day Scheduling
- Smooth Setback Recovery
- Heat/Cool Auto-changeover
- Wired Temperature/Humidity Room Sensor (Non-Communicating)**



- Terminal blocks for wiring connections
- Five-wire sensor connection
- Off-white plastic enclosure
- Non-adjustable
- Relative humidity range: 0 -100%
- +/- 3% Accuracy

## OPTIONAL CONVENTIONAL TEMPERATURE CONTROL SYSTEMS

Description	Order Number
<b>CS8500 Commercial 7 Day Programmable Thermostat</b>	
CS8500 7-Day Thermostat	No CO <sub>2</sub> Sensing <b>24K55</b>
	With CO <sub>2</sub> Sensing <b>24K53</b>
Sensors/Accessories	<sup>1</sup> Remote non-adjustable wall-mount 10k <b>47W37</b>
	<sup>1</sup> Remote non-adjustable wall-mount 11k <b>94L61</b>
<b>CS7500 Commercial 7-Day Programmable Thermostat</b>	
CS7500 7-Day Thermostat	<b>24K41</b>
Sensors/Accessories	<sup>2</sup> Remote non-adjustable wall-mount 20k <b>47W36</b>
	<sup>2</sup> Remote non-adjustable wall-mount 10k <b>47W37</b>
	Remote non-adjustable discharge air (duct mount) <b>19L22</b>
	Outdoor temperature sensor <b>X2658</b>
<b>CS3000 Commercial 5-2 Day Programmable Thermostat</b>	
CS3000 5-2 Day Thermostat	<b>11Y05</b>
Sensors/Accessories	Remote non-adjustable wall mount 10k averaging <b>47W37</b>
	Thermostat wall mounting plate <b>X2659</b>
<b>Universal Thermostat Guard with Lock (clear)</b>	
	Inside Dimensions (H x W x D) 5-7/8 x 8-3/8 x 3 in. <b>39P21</b>
<b>Temperature/Humidity Room Sensor</b>	
A335MT13AE1 Wired Temperature/Humidity Room Sensor (Non-Communicating)	<b>21W06</b>

<sup>1</sup> Up to nine of the same type remote temperature sensors can be connected in parallel.

<sup>2</sup> Remote wall-mount sensors can be applied in any of the following combinations:  
One Sensor - (1) 47W36, Two Sensors - (2) 47W37, Three Sensors - (2) 47W36 and (1) 47W37  
Four Sensors - (4) 47W36, Five Sensors - (3) 47W36 and (2) 47W37

**180/210/240/300 MODELS (3 AND 4 COMPRESSORS)****UNIT OPERATION WITH 2-STAGE THERMOSTAT (2 COOLING STAGES, Y1, Y2)****SUPPLY AIR BLOWER SPEED**

Unit has following supply air blower speed setting:

- Ventilation speed
- Cooling Speed - Low
- Cooling Speed - High
- Heating Speed
- Smoke Speed (Using only in smoke removal option - not discussed)

**COOLING****<sup>1</sup> Unit Features and Economizer and Outdoor Air is Suitable****Thermostat Mode (Y1, Y2)****Y1 Demand:**

All compressors are off, supply air blower is on low cooling speed to minimize blower power consumption, economizer modulates (minimum to maximum open position) to maintain 55°F supply air temperature (default unit controller setting).

**Y2 Demand:**

All compressors are off, supply air blower is on high cooling speed providing higher cooling capacity, and economizer modulates to maintain 55°F supply air temperature. If economizer stays at maximum open for 3 minutes, 1st stage compressors (compressor 1 and 2) are energized while supply air blower stays on high cooling speed providing maximum cooling capacity.

<sup>1</sup> Outdoor air suitability is determined by the energy state of outdoor ambient (enthalpy or sensible) and its ability to achieve the desired free cooling effects. Outdoor air suitability can also be determined by a third party controller and provided to the rooftop unit via a network connection.

**Unit Does Not Feature An Economizer Or Outdoor Air Is Not Suitable****Thermostat Mode (Y1, Y2)****Y1 Demand:**

1st stage compressors 1 & 2 operate and supply air blower operates at low cooling speed.

**Y2 Demand:**

All compressors operate and supply air blower operates at high cooling speed.

**Dehumidification Mode**

If a unit with Humiditrol® Dehumidification Option receives a call for dehumidification, economizer free cooling is locked out.

**Call For Dehumidification, No Y1, Y2 Demand:**

1st stage compressors (1 & 2) operate, supply air blower operates at low cooling speed, and the reheat valves are energized.

**Y1 Demand With A Call For Dehumidification:**

All compressors operate, supply air blower operates at high cooling speed and the reheat valves are energized.

**Y2 Demand With A Call For Dehumidification:**

All compressors operate, supply air blower operates at high cooling speed, and the reheat valves are de-energized.

**180/210/240/300 MODELS (3 AND 4 COMPRESSORS)****ZONE SENSOR****SUPPLY AIR BLOWER SPEED**

Unit has following supply air blower speed setting:

- Ventilation speed
- Cooling Speed - Low
- Cooling Speed - High
- Heating Speed
- Smoke Speed (Using only in smoke removal option - not discussed)

**COOLING****<sup>1</sup> Unit Features and Economizer and Outdoor Air is Suitable****3 Compressor Units****Y1 Demand:**

All compressors are off, supply air blower is on low cooling speed to minimize blower power consumption, economizer modulates (minimum to maximum open position) to maintain 55°F supply air temperature (default unit controller setting).

**Y2 Demand:**

All compressors are off, supply air blower is on high cooling speed providing higher cooling capacity, economizer modulates (minimum to maximum open position) to maintain 55°F supply air temperature (default unit controller setting).

If economizer stays at maximum open for 3 minutes then compressor 1 is energized while supply air blower stays on high cooling speed. After compressor is energized the economizer stays at maximum open.

**Y3 Demand:**

Compressors 1 and 2 are energized while supply air blower stays on high cooling speed. After compressors are energized the economizer stays at maximum.

**Y4 (Zone Sensor Only) Demand:**

All compressors are energized and supply air blower stays on high cooling speed.

**4 Compressor Units****Y1 Demand:**

All compressors are off, supply air blower is on low cooling speed to minimize blower power consumption, economizer modulates (minimum to maximum open position) to maintain 55°F supply air temperature (default unit controller setting).

**Y2 Demand:**

All compressors are off, supply air blower is on high cooling speed providing higher cooling capacity, economizer modulates (minimum to maximum open position) to maintain 55°F supply air temperature (default unit controller setting).

If economizer stays at maximum open for 3 minutes then compressors 1 and 2 are energized while supply air blower stays on high cooling speed. After compressors are energized the economizer stays at maximum open.

**Y3 Demand:**

Compressors 1, 2 and 3 are energized and supply air blower stays on high cooling speed.

**Y4 Demand (Zone Sensor Only):**

All compressors are energized and supply air blower stays on high cooling speed.

<sup>1</sup> Outdoor air suitability is determined by the energy state of outdoor ambient (enthalpy or sensible) and its ability to achieve the desired free cooling effects. Outdoor air suitability can also be determined by a third party controller and provided to the rooftop unit via a network connection.

**Dehumidification Mode**

If a unit with Humiditrol® Dehumidification Option receives a call for dehumidification, economizer free cooling is locked out.

**Call For Dehumidification, No Y1, Y2, Y3 Demand:**

Compressor 1 and 2 operate, supply air blower operates at low cooling speed, and both reheat valves are energized.

**Y1 Demand With A Call For Dehumidification:**

All compressors operate, supply air blower operates at high cooling speed and both reheat valves are energized.

**Y2 Demand With A Call For Dehumidification:**

All compressors operate, supply air blower operates at high cooling speed, and the reheat valve of refrigeration circuit 1 is energized while the reheat valve of refrigeration circuit 2 is de-energized.

**Y3 or Y4 (Zone Sensor Only) Demand:**

All compressors operate, supply air blower operates at high cooling speed, and both reheat valves are de-energized.

**Heating Mode (Electric Heat)**

*NOTE - HEATING MODE IS THE SAME FOR ALL CONTROL OPTIONS*

**W1 Demand:**

1st stage elect heat is energized and the supply air blower operates at heating speed.

**W2 Demand:**

2nd stage electric heat is energized and the supply air blower operates at heating speed (45, 60 or 90 kW electric heat option only).

**ACCESSORIES****Modulating Outdoor Air Damper**

The minimum damper position for “occupied low blower” and “occupied high blower” is adjusted during unit setup to provide minimum fresh air requirements per ASHRAE 62.1 at the corresponding supply air blower speeds.

- When supply air blower is off or the unit is in unoccupied mode, the outdoor air damper is closed.
- When unit is in occupied mode and supply air blower is operating at a speed below the “midpoint” blower speed, the outdoor air damper is at minimum “low blower” position.
- When unit is in occupied mode and supply air blower is operating at a speed equal to or above the “midpoint” blower speed, the outdoor air damper is at minimum “high blower” position.

*NOTE - The “midpoint” blower speed is an average of the minimum and maximum blower speed (minimum speed + maximum speed divided by 2).*

**Power Exhaust Operation**

*NOTE - POWER EXHAUST OPERATION IS THE SAME FOR ALL CONTROL OPTIONS*

MSAV® Multi-Stage Air Volume models are equipped with 2-stage power exhaust fans. Power exhaust fans operate when economizer outdoor air dampers are 50% open (adjustable). Power exhaust operates in 1st stage (one fan) up to 70% of supply air blower speed. 2nd stage power exhaust fans (both fans) operate when supply air blower speed is above 70% (adjustable) of full speed.

## OPTIONS / ACCESSORIES

Item Description	Order Number	Size			
		180	210	240	300
<b>COOLING SYSTEM</b>					
Condensate Drain Trap	PVC <b>22H54</b>	X	X	X	X
	Copper <b>76W27</b>	X	X	X	X
Drain Pan Overflow Switch	<b>21Z07</b>	X	X	X	X
Low Ambient Kits (0°F)	<b>37G59</b>	X	X		
	<b>37G60</b>			X	
	<b>37G63</b>				X
<b>BLOWER - SUPPLY AIR</b>					
Blower Motors	Belt Drive - 3 HP Factory	O	O		
	Belt Drive - 5 HP Factory	O	O	O	O
	Belt Drive 7.5 HP Factory	O	O	O	O
	Belt Drive 10 HP Factory			O	O
VFD Bypass Kit	3, 5, 7.5 HP - No Overload <b>37G64</b>	X	X	X	X
	10 HP - With Overload <b>37G65</b>			X	X
Drive Kits See Blower Data Tables for usage and selection	Kit #1 535-725 rpm Factory	O	O		
	Kit #2 710-965 rpm Factory	O	O		
	Kit #3 685-856 rpm Factory	O	O	O	O
	Kit #4 850-1045 rpm Factory	O	O	O	O
	Kit #5 945-1185 rpm Factory	O	O	O	O
	Kit #6 850-1045 rpm Factory	O	O	O	O
	Kit #7 945-1185 rpm Factory	O	O	O	O
	Kit #8 1045-1285 rpm Factory	O	O	O	O
	Kit #10 1045-1285 rpm Factory			O	O
	Kit #11 1135-1330 rpm Factory			O	O
	Blower Belt Auto-Tensioner <b>24B80</b>	X	X	X	X
<b>CABINET</b>					
Burglar Bars	(US) <b>44N20</b>	X	X	X	X
	(CA) <b>X2889</b>	X	X	X	X
Combination Coil/Hail Guards	<b>23U69</b>	OX	OX		
	<b>23U71</b>			OX	OX
Hinged Access Panels	Factory	O	O	O	O
<b>CONTROLS</b>					
BACnet® MS/TP Module	<b>38B35</b>	X	X	X	X
Dirty Filter Switch	<b>53W68</b>	X	X	X	X
Smoke Detector - Supply or Return (Power board and one sensor)	<b>37G73</b>	X	X	X	X
Smoke Detector - Supply and Return (Power board and two sensors)	<b>37G74</b>	X	X	X	X

NOTE - Order numbers shown are for ordering field installed accessories.

OX - Configure To Order (Factory Installed) or Field Installed

O = Configure To Order (Factory Installed)

X = Field Installed

## OPTIONS / ACCESSORIES

Item Description	Order Number	Size				
		180	210	240	300	
<b>ELECTRICAL</b>						
Voltage 60 Hz	208/230V - 3 phase	Factory	O	O	O	O
	460V - 3 phase	Factory	O	O	O	O
	575V - 3 phase	Factory	O	O	O	O
Disconnect Switch (see Electric Heat Tables for usage)	80 amp	<b>54W85</b>	OX	OX	OX	OX
	150 amp	<b>54W86</b>	OX	OX	OX	OX
	250 amp	<b>54W87</b>	OX	OX	OX	OX
GFI Service Outlets	15 amp non-powered, field-wired (208/230V, 460V only)	<b>74M70</b>	OX	OX	OX	OX
	<sup>1</sup> 20 amp non-powered, field-wired (208/230V, 460V, 575V)	<b>67E01</b>	X	X	X	X
	<sup>1</sup> 20 amp non-powered, field-wired (575V)	Factory	O	O	O	O
Weatherproof Cover for GFI		<b>10C89</b>	X	X	X	X
<b>ELECTRIC HEAT</b>						
15 kW	208/240V-3ph	<b>30U62</b>	X	X	X	X
	460V-3ph	<b>30U63</b>	X	X	X	X
	575V-3ph	<b>30U64</b>	X	X	X	X
30 kW	208/240V-3ph	<b>30U65</b>	X	X	X	X
	460V-3ph	<b>30U66</b>	X	X	X	X
	575V-3ph	<b>30U67</b>	X	X	X	X
45 kW	208/240V-3ph	<b>30U71</b>	X	X	X	X
	460V-3ph	<b>30U72</b>	X	X	X	X
	575V-3ph	<b>30U73</b>	X	X	X	X
60 kW	208/240V-3ph	<b>30U77</b>	X	X	X	X
	460V-3ph	<b>30U78</b>	X	X	X	X
	575V-3ph	<b>30U79</b>	X	X	X	X
90 kW	208/240V-3ph	<b>30U83</b>		X	X	X
	460V-3ph	<b>30U84</b>		X	X	X
	575V-3ph	<b>30U85</b>		X	X	X
<b>HUMIDITROL® DEHUMIDIFICATION REHEAT OPTION</b>						
Humiditrol® Dehumidification Option		Factory	O	O	O	O

<sup>1</sup> Canada requires a minimum 20 amp circuit. Select 20 amp, non-powered, field wired GFI.

NOTE - Order numbers shown are for ordering field installed accessories.

OX - Configure To Order (Factory Installed) or Field Installed

O = Configure To Order (Factory Installed)

X = Field Installed

## OPTIONS / ACCESSORIES

Item Description	Order Number	Size				
		180	210	240	300	
<b>INDOOR AIR QUALITY</b>						
<b>Air Filters</b>						
Healthy Climate® High Efficiency Air Filters 24 x 24 x 2 in. (Order 6 per unit)	MERV 8	<b>54W67</b>	X	X	X	X
	MERV 13	<b>52W40</b>	X	X	X	X
	MERV 16	<b>21U42</b>	X	X	X	X
Replacement Media Filter With Metal Mesh Frame (includes non-pleated filter media)		<b>44N61</b>	X	X	X	X
<b>Indoor Air Quality (CO<sub>2</sub>) Sensors</b>						
Sensor - Wall-mount, off-white plastic cover with LCD display		<b>77N39</b>	X	X	X	X
Sensor - Wall-mount, off-white plastic cover, no display		<b>87N53</b>	X	X	X	X
Sensor - Black plastic case, LCD display, rated for plenum mounting		<b>87N52</b>	X	X	X	X
Sensor - Black plastic case, no display, rated for plenum mounting		<b>87N54</b>	X	X	X	X
CO <sub>2</sub> Sensor Duct Mounting Kit - for downflow applications		<b>23Y47</b>	X	X	X	X
Aspiration Box - for duct mounting non-plenum rated CO <sub>2</sub> sensors ( <b>77N39</b> )		<b>90N43</b>	X	X	X	X
<b>UVC Germicidal Light Kit</b>						
<sup>2</sup> Healthy Climate® UVC Light Kit (110/230V-1ph)		<b>21A94</b>	X	X	X	X
Step-Down Transformers	460V primary, 230V secondary	<b>10H20</b>	X	X	X	X
	575V primary, 230V secondary	<b>10H21</b>	X	X	X	X
<b>Needlepoint Bipolar Ionization (NPBI)</b>						
Needlepoint Bipolar Ionization (NPBI) Kits		<b>21U37</b>	X	X		
		<b>21U38</b>			X	
		<b>21U39</b>				X
<b>ECONOMIZER</b>						
<b>High Performance Economizer (Approved for California Title 24 Building Standards AMCA Class 1A Certified)</b>						
High Performance Economizer (Downflow or Horizontal) Includes Economizer Dampers with Outdoor Air Hood Downflow Applications - Use furnished Outdoor Air Hood - Order Downflow Barometric Relief Dampers with Exhaust Hood separately Horizontal Applications - Use furnished Outdoor Air Hood - Order Horizontal Barometric Relief Dampers with Exhaust Hood separately		<b>22J18</b>	OX	OX	OX	OX
<b>Economizer Controls</b>						
Differential Enthalpy (Not for Title 24)	Order 2	<b>21Z09</b>	X	X	X	X
Sensible Control	Sensor is Furnished	Factory	O	O	O	O
Single Enthalpy (Not for Title 24)		<b>21Z09</b>	OX	OX	OX	OX
<b>Barometric Relief Dampers With Exhaust Hood</b>						
Downflow Barometric Relief Dampers		<b>54W78</b>	OX	OX	OX	OX
Horizontal Barometric Relief Dampers		<b>16K99</b>	X	X	X	X

<sup>2</sup> Lamps operate on 110-230V single-phase power supply. Step-down transformer may be ordered separately for 460V and 575V units. Alternately, 110V power supply may be used to directly power the UVC ballast(s).

NOTE - Order numbers shown are for ordering field installed accessories.

OX - Configure To Order (Factory Installed) or Field Installed

O = Configure To Order (Factory Installed)

X = Field Installed

## OPTIONS / ACCESSORIES

Item Description	Order Number	Size				
		180	210	240	300	
<b>OUTDOOR AIR</b>						
<b>Outdoor Air Dampers With Outdoor Air Hood</b>						
Motorized	22J27	X	X	X	X	
Manual	13U05	X	X	X	X	
<b><sup>3</sup> POWER EXHAUST (DOWNFLOW APPLICATIONS ONLY)</b>						
Standard Static, SCCR Rated	208/230V	22H90	X	X	X	X
	460V	22H91	X	X	X	X
	575V	22V34	X	X	X	X
<b>ROOF CURBS</b>						
<b>Hybrid Roof Curbs, Downflow</b>						
8 in. height	11F58	X	X	X	X	
14 in. height	11F59	X	X	X	X	
18 in. height	11F60	X	X	X	X	
24 in. height	11F61	X	X	X	X	
<b>Adjustable Pitch Curb</b>						
14 in. height	43W26	X	X	X	X	
<b>Standard Roof Curbs, Horizontal - Requires Horizontal Return Air Panel Kit</b>						
26 in. height - slab applications	11T89	X	X	X		
30 in. height - slab applications	11T90				X	
37 in. height - rooftop applications	11T96	X	X	X		
41 in. height - rooftop applications	11T97				X	
<b>Insulation Kit For Standard Horizontal Curbs</b>						
For 26 in. Curb	73K32	X	X	X		
For 30 in. Curb	73K33				X	
For 37 in. Curb	73K34	X	X	X		
For 41 in. Curb	73K35				X	
<b>Horizontal Return Air Panel Kit</b>						
Required for Horizontal Applications with Roof Curb	87M00	X	X	X	X	
<b>CEILING DIFFUSERS</b>						
Step-Down - Order one	13K63	X				
	13K64		X	X	X	
Flush - Order one	13K58	X				
	13K59		X	X	X	
Transitions (Supply and Return) - Order one	12X68	X				
	12X70		X	X	X	

<sup>3</sup> Field installed Power Exhaust requires Economizer with Outdoor Air Hood and Downflow Barometric Relief Dampers with Exhaust Hood. Must be ordered separately.

NOTE - Order numbers shown are for ordering field installed accessories.

OX - Configure To Order (Factory Installed) or Field Installed

O = Configure To Order (Factory Installed)

X = Field Installed

## SPECIFICATIONS

Model		LCX180S5M	LCX210S5M	LCX240S5M	LCX300S5M	
<b>Nominal Tonnage</b>		15 Ton	17.5 Ton	20 Ton	25 Ton	
<b>Efficiency Type</b>		Standard	Standard	Standard	Standard	
<b>Blower Type</b>		MSAV® Multi-Stage Air Volume	MSAV® Multi-Stage Air Volume	MSAV® Multi-Stage Air Volume	MSAV® Multi-Stage Air Volume	
<b>Cooling Performance</b>	Gross Cooling Capacity - Btuh	178,000	206,000	236,000	282,000	
	<sup>1</sup> Net Cooling Capacity - Btuh	172,000	200,000	228,000	270,000	
	<sup>1</sup> AHRI Rated Air Flow - cfm	7200	6150	7100	7450	
	Total Unit Power - kW	15.6	18.2	20.7	27	
	<sup>1</sup> IEER (Btuh/Watt)	14.2	14.2	14.2	13.2	
	<sup>1</sup> EER (Btuh/Watt)	11.0	11.0	11.0	10.0	
<b>Sound Rating Number</b>	dBa	86	86	93	94	
<b>Refrigerant Charge</b>	Refrigerant Type	R-454B	R-454B	R-454B	R-454B	
Without Reheat Option	Circuit 1	6 lbs. 11 oz.	6 lbs. 14 oz.	7 lbs. 4 oz.	5 lbs. 15 oz.	
		Circuit 2	5 lbs. 3 oz.	6 lbs. 14 oz.	7 lbs. 2 oz.	5 lbs. 8 oz.
		Circuit 3	5 lbs. 5 oz.	6 lbs. 10 oz.	6 lbs. 15 oz.	5 lbs. 5 oz.
		Circuit 4	---	---	---	5 lbs. 6 oz.
	With Reheat Option	Circuit 1	6 lbs. 4 oz.	6 lbs. 4 oz.	7 lbs. 10 oz.	6 lbs. 15 oz.
		Circuit 2	6 lbs. 0 oz.	6 lbs. 4 oz.	7 lbs. 4 oz.	6 lbs. 5 oz.
		Circuit 3	5 lbs. 12 oz.	5 lbs. 15 oz.	6 lbs. 15 oz.	4 lbs. 11 oz.
		Circuit 4	---	---	---	5 lbs. 3 oz.
<b>Electric Heat Available, see page 20</b>		15-30-45-60 kW		15-30-45-60-90 kW		
<b>Compressor Type (number)</b>		Scroll (3)	Scroll (3)	Scroll (3)	Scroll (4)	
<b>Outdoor Coils</b>	Net face area - ft. <sup>2</sup> (total)	41.1	41.1	55.0	55.0	
	Rows	1	1	1	1	
	Fins - in.	23	23	23	23	
<b>Outdoor Coil Fans</b>	Motor HP (number and type)	1/3 (3 PSC)	1/3 (3 PSC)	1/3 (4 PSC)	1/3 (6 PSC)	
	Rpm	1075	1075	1075	1075	
	Watts	1100	1100	1665	1950	
	Diameter - (No.) in.	(3) 24	(3) 24	(4) 24	(6) 24	
	Blades	3	3	3	3	
	Total Air volume - cfm	12,000	12,000	16,000	20,000	
<b>Indoor Coils</b>	Net face area - ft. <sup>2</sup> (total)	21.4	21.4	21.4	21.4	
	Tube diameter - in.	3/8	3/8	3/8	3/8	
	Rows	3	4	4	4	
	Fins - in.	14	14	14	14	
	Condensate drain size (NPT) - in.	(1) 1	(1) 1	(1) 1	(1) 1	
	Expansion device type	Balanced Port Thermostatic Expansion Valve, removable element head				
<b><sup>2</sup> Indoor Blower and Drive Selection</b>	Nominal motor HP	3, 5, 7.5		5, 7.5, 10		
	Maximum usable motor HP (US)	3.45, 5.75, 8.62		5.75, 8.62, 11.5		
	Motor - Drive kit number	3 HP		5 HP		
		Kit 1 535-725 rpm		Kit 3 685-856 rpm		
		Kit 2 710-965 rpm		Kit 4 850-1045 rpm		
		5 HP		Kit 5 945-1185 rpm		
		Kit 3 685-856 rpm		7.5 HP		
		Kit 4 850-1045 rpm		Kit 6 850-1045 rpm		
		Kit 5 945-1185 rpm		Kit 7 945-1185 rpm		
		7.5 HP		Kit 8 1045-1285 rpm		
		Kit 6 850-1045 rpm		10 HP		
	Kit 7 945-1185 rpm		Kit 7 945-1185 rpm			
	Kit 8 1045-1285 rpm		Kit 10 1045-1285 rpm			
				Kit 11 1135-1330 rpm		
	Wheel (Number) diameter x width - in.	(2) 15 x 15				
<b>Filters</b>	Type of filter	MERV 4, Disposable				
	Number and size - in.	(6) 24 x 24 x 2				
<b>Line voltage data (Volts-Phase-Hz)</b>		208/230-3-60 460-3-60 575-3-60				

NOTE - Net capacity includes evaporator blower motor heat deduction. Gross capacity does not include evaporator blower motor heat deduction.

<sup>1</sup> AHRI Certified to AHRI Standard 340/360; 95°F outdoor air temperature and 80°F db/67°F wb entering evaporator air; minimum external duct static pressure.

<sup>2</sup> Using total air volume and system static pressure requirements determine from blower performance tables rpm and motor output required. Maximum usable output of motors furnished are shown. In Canada, nominal motor output is also maximum usable motor output. If motors of comparable output are used, be sure to keep within the service factor limitations outlined on the motor nameplate.

NOTE - Motor service factor limit - 1.0.

# RATINGS

NOTE - For Temperatures and Capacities not shown in tables, see bulletin - Cooling Unit Rating Table Correction Factor Data in Miscellaneous Engineering Data section.

## 15 TON - LCX180S5M (PART LOAD)

Entering Wet Bulb Temperature	Total Air Volume	Outdoor Air Temperature Entering Outdoor Coil																			
		65°F					75°F					85°F					95°F				
		Total Cool Cap.	Comp. Motor Input	Sensible To Total Ratio (S/T)			Total Cool Cap.	Comp. Motor Input	Sensible To Total Ratio (S/T)			Total Cool Cap.	Comp. Motor Input	Sensible To Total Ratio (S/T)			Total Cool Cap.	Comp. Motor Input	Sensible To Total Ratio (S/T)		
				Dry Bulb					Dry Bulb					Dry Bulb					Dry Bulb		
cfm	kBtuh	kW	75°F	80°F	85°F	kBtuh	kW	75°F	80°F	85°F	kBtuh	kW	75°F	80°F	85°F	kBtuh	kW	75°F	80°F	85°F	
63°F	3500	120.2	4.95	0.76	0.85	0.95	113.2	5.79	0.77	0.86	0.96	106.7	6.65	0.77	0.87	0.97	100.3	7.55	0.77	0.88	0.97
	4000	124.1	4.96	0.78	0.88	0.97	117.6	5.81	0.78	0.89	0.98	111	6.66	0.79	0.9	0.98	104.2	7.57	0.79	0.91	0.99
	4500	128	4.98	0.8	0.9	0.98	121.4	5.82	0.8	0.91	0.99	114.5	6.67	0.81	0.93	1	107.5	7.58	0.81	0.94	1
67°F	3500	125.7	4.97	0.66	0.75	0.83	119.3	5.82	0.65	0.75	0.83	112.8	6.67	0.65	0.75	0.84	105.7	7.57	0.65	0.75	0.86
	4000	130.6	4.98	0.67	0.76	0.85	124	5.83	0.66	0.77	0.86	117.1	6.68	0.66	0.77	0.88	109.3	7.58	0.66	0.78	0.88
	4500	134.5	4.99	0.68	0.78	0.88	127.7	5.84	0.68	0.79	0.89	120.6	6.69	0.67	0.79	0.9	112.8	7.6	0.67	0.8	0.92
71°F	3500	132.2	4.99	0.55	0.64	0.73	125.7	5.83	0.54	0.64	0.73	118.9	6.69	0.53	0.64	0.74	111.7	7.59	0.53	0.64	0.74
	4000	136.9	5	0.55	0.66	0.75	130.1	5.85	0.55	0.66	0.75	122.9	6.7	0.54	0.65	0.76	115	7.61	0.54	0.65	0.76
	4500	140.7	5.01	0.56	0.67	0.77	134	5.86	0.56	0.67	0.77	126.3	6.71	0.55	0.67	0.78	119.6	7.62	0.54	0.66	0.78

## 15 TON - LCX180S5M (FULL LOAD)

Entering Wet Bulb Temperature	Total Air Volume	Outdoor Air Temperature Entering Outdoor Coil																			
		85°F					95°F					105°F					115°F				
		Total Cool Cap.	Comp. Motor Input	Sensible To Total Ratio (S/T)			Total Cool Cap.	Comp. Motor Input	Sensible To Total Ratio (S/T)			Total Cool Cap.	Comp. Motor Input	Sensible To Total Ratio (S/T)			Total Cool Cap.	Comp. Motor Input	Sensible To Total Ratio (S/T)		
				Dry Bulb					Dry Bulb					Dry Bulb					Dry Bulb		
cfm	kBtuh	kW	75°F	80°F	85°F	kBtuh	kW	75°F	80°F	85°F	kBtuh	kW	75°F	80°F	85°F	kBtuh	kW	75°F	80°F	85°F	
63°F	4800	169.2	9.86	0.71	0.86	0.99	158.5	11.19	0.72	0.87	1	146.9	12.64	0.73	0.89	1	134.6	14.29	0.74	0.92	1
	6000	178.3	9.9	0.77	0.93	1	166.2	11.22	0.78	0.95	1	154.2	12.67	0.79	0.98	1	142.6	14.33	0.81	1	1
	7200	185.8	9.92	0.82	0.99	1	174.2	11.25	0.83	1	1	162.8	12.71	0.86	1	1	150.9	14.36	0.88	1	1
67°F	4800	181	9.91	0.55	0.69	0.82	169.1	11.23	0.55	0.7	0.84	157.5	12.69	0.55	0.7	0.86	144.9	14.34	0.55	0.72	0.88
	6000	189.9	9.94	0.59	0.74	0.9	177.9	11.27	0.59	0.76	0.92	165.1	12.72	0.59	0.77	0.94	152.1	14.36	0.59	0.79	0.97
	7200	196.7	9.96	0.62	0.8	0.96	183.6	11.29	0.62	0.82	0.99	170.5	12.74	0.63	0.84	1	156.6	14.38	0.64	0.86	1
71°F	4800	192.4	9.95	0.41	0.54	0.67	180.7	11.28	0.4	0.54	0.67	167.5	12.73	0.39	0.54	0.68	154.9	14.37	0.37	0.54	0.7
	6000	201.5	9.98	0.42	0.58	0.72	189	11.31	0.41	0.58	0.74	176.2	12.76	0.4	0.58	0.75	162.3	14.4	0.4	0.59	0.77
	7200	208.3	10	0.43	0.61	0.78	195.4	11.33	0.43	0.62	0.8	181.7	12.78	0.42	0.63	0.82	167.8	14.42	0.42	0.64	0.84

## 17.5 TON - LCX210S5M (PART LOAD)

Entering Wet Bulb Temperature	Total Air Volume	Outdoor Air Temperature Entering Outdoor Coil																			
		65°F					75°F					85°F					95°F				
		Total Cool Cap.	Comp. Motor Input	Sensible To Total Ratio (S/T)			Total Cool Cap.	Comp. Motor Input	Sensible To Total Ratio (S/T)			Total Cool Cap.	Comp. Motor Input	Sensible To Total Ratio (S/T)			Total Cool Cap.	Comp. Motor Input	Sensible To Total Ratio (S/T)		
				Dry Bulb					Dry Bulb					Dry Bulb					Dry Bulb		
cfm	kBtuh	kW	75°F	80°F	85°F	kBtuh	kW	75°F	80°F	85°F	kBtuh	kW	75°F	80°F	85°F	kBtuh	kW	75°F	80°F	85°F	
63°F	4000	153.4	6.42	0.79	0.87	0.96	146.7	7.31	0.79	0.88	0.97	140.1	8.31	0.8	0.89	0.97	131.8	9.41	0.8	0.9	0.98
	4750	160.5	6.49	0.81	0.9	0.98	153.3	7.39	0.81	0.91	0.99	145.3	8.37	0.82	0.93	0.99	138	9.49	0.83	0.94	1
	5500	165.9	6.55	0.83	0.94	1	158.6	7.45	0.84	0.95	1	150.2	8.44	0.84	0.96	1	142.3	9.55	0.86	0.97	1
67°F	4000	161.7	6.51	0.69	0.77	0.85	154.7	7.41	0.69	0.77	0.86	147.2	8.4	0.69	0.78	0.87	139.1	9.51	0.69	0.79	0.88
	4750	169	6.59	0.7	0.79	0.88	161.4	7.49	0.7	0.8	0.89	153.4	8.48	0.7	0.8	0.91	144.8	9.59	0.71	0.81	0.92
	5500	174.7	6.65	0.71	0.81	0.91	165.9	7.54	0.72	0.82	0.93	158.3	8.55	0.72	0.83	0.94	149.4	9.66	0.72	0.84	0.96
71°F	4000	169.5	6.59	0.59	0.68	0.75	162.5	7.5	0.59	0.68	0.76	154	8.49	0.59	0.68	0.76	146	9.61	0.58	0.68	0.77
	4750	177.3	6.68	0.6	0.69	0.78	168.7	7.58	0.6	0.69	0.78	160.7	8.58	0.59	0.69	0.79	152.6	9.71	0.59	0.7	0.8
	5500	182.7	6.75	0.6	0.7	0.8	174.1	7.65	0.6	0.71	0.81	165.5	8.65	0.6	0.71	0.82	156.7	9.77	0.6	0.72	0.83

## 17.5 TON - LCX210S5M (FULL LOAD)

Entering Wet Bulb Temperature	Total Air Volume	Outdoor Air Temperature Entering Outdoor Coil																			
		85°F					95°F					105°F					115°F				
		Total Cool Cap.	Comp. Motor Input	Sensible To Total Ratio (S/T)			Total Cool Cap.	Comp. Motor Input	Sensible To Total Ratio (S/T)			Total Cool Cap.	Comp. Motor Input	Sensible To Total Ratio (S/T)			Total Cool Cap.	Comp. Motor Input	Sensible To Total Ratio (S/T)		
				Dry Bulb					Dry Bulb					Dry Bulb					Dry Bulb		
cfm	kBtuh	kW	75°F	80°F	85°F	kBtuh	kW	75°F	80°F	85°F	kBtuh	kW	75°F	80°F	85°F	kBtuh	kW	75°F	80°F	85°F	
63°F	5600	210.4	12.57	0.72	0.86	0.99	200	14.27	0.72	0.87	1	186.4	16.17	0.74	0.9	1	174.5	18.41	0.75	0.92	1
	7000	221	12.73	0.77	0.94	1	209.3	14.41	0.78	0.95	1	196.1	16.33	0.8	0.98	1	183.9	18.58	0.82	1	1
	8400	231.1	12.88	0.83	0.99	1	218.5	14.56	0.84	1	1	206.5	16.51	0.87	1	1	193.7	18.76	0.89	1	1
67°F	5600	224.8	12.78	0.56	0.69	0.82	212.7	14.47	0.56	0.7	0.84	199.6	16.38	0.57	0.71	0.86	186.4	18.62	0.57	0.73	0.89
	7000	234.4	12.93	0.59	0.75	0.9	222	14.62	0.6	0.76	0.93	208.4	16.54	0.61	0.78	0.95	193.8	18.76	0.61	0.8	0.98
	8400	242.1	13.05	0.63	0.81	0.97	228.4	14.73	0.64	0.83	0.99	214.1	16.65	0.65	0.85	1	199.3	18.85	0.66	0.87	1
71°F	5600	238.7	12.99	0.42	0.55	0.67	226.3	14.69	0.41	0.55	0.68	212.3	16.61	0.41	0.55	0.69	198.3	18.83	0.4	0.56	0.71
	7000	248.9	13.16	0.43	0.59	0.73	235.3	14.85	0.43	0.59	0.74	221.1	16.77	0.43	0.6	0.76	206.5	18.99	0.43	0.61	0.78
	8400	256.4	13.28	0.45	0.62	0.79	242.5	14.97	0.45	0.63	0.81	227.9	16.89	0.45	0.64	0.83	211.9	19.08	0.45	0.65	0.85

# RATINGS

NOTE - For Temperatures and Capacities not shown in tables, see bulletin - Cooling Unit Rating Table Correction Factor Data in Miscellaneous Engineering Data section.

## 20 TON - LCX240S5M (PART LOAD)

Entering Wet Bulb Temperature	Total Air Volume	Outdoor Air Temperature Entering Outdoor Coil																			
		65°F					75°F					85°F					95°F				
		Total Cool Cap.	Comp. Motor Input	Sensible To Total Ratio (S/T)			Total Cool Cap.	Comp. Motor Input	Sensible To Total Ratio (S/T)			Total Cool Cap.	Comp. Motor Input	Sensible To Total Ratio (S/T)			Total Cool Cap.	Comp. Motor Input	Sensible To Total Ratio (S/T)		
				Dry Bulb					Dry Bulb					Dry Bulb					Dry Bulb		
cfm	kBtuh	kW	75°F	80°F	85°F	kBtuh	kW	75°F	80°F	85°F	kBtuh	kW	75°F	80°F	85°F	kBtuh	kW	75°F	80°F	85°F	
63°F	4500	171	6.96	0.79	0.87	0.96	163.6	8.06	0.79	0.88	0.97	156.5	9.23	0.8	0.89	0.98	149.5	10.51	0.8	0.9	0.98
	5500	179.9	6.96	0.81	0.91	0.99	172.1	8.08	0.82	0.92	0.99	163.9	9.27	0.82	0.94	1	156.4	10.56	0.83	0.95	1
	6500	186.6	6.95	0.84	0.95	1	178.5	8.09	0.85	0.96	1	170.2	9.3	0.85	0.97	1	161.7	10.6	0.87	0.98	1
67°F	4500	180.3	6.96	0.69	0.77	0.85	172.9	8.08	0.69	0.77	0.86	164.8	9.28	0.69	0.78	0.87	157.5	10.57	0.69	0.79	0.88
	5500	189.8	6.95	0.7	0.79	0.89	181.8	8.1	0.7	0.8	0.9	172.7	9.32	0.71	0.81	0.91	164.4	10.63	0.71	0.82	0.92
71°F	6500	196.7	6.94	0.72	0.82	0.92	187.8	8.11	0.72	0.83	0.94	179	9.34	0.73	0.84	0.95	169.9	10.66	0.73	0.85	0.96
	4500	189.2	6.95	0.59	0.67	0.75	181.6	8.1	0.58	0.68	0.76	173.1	9.32	0.59	0.68	0.76	165.4	10.64	0.58	0.68	0.77
	5500	199.3	6.94	0.6	0.69	0.78	191	8.11	0.6	0.69	0.79	181.5	9.35	0.6	0.7	0.79	172.7	10.68	0.6	0.7	0.8
	6500	206.1	6.92	0.61	0.71	0.8	197.2	8.12	0.61	0.71	0.81	188.5	9.38	0.61	0.72	0.82	178.9	10.73	0.61	0.72	0.83

## 20 TON - LCX240S5M (FULL LOAD)

Entering Wet Bulb Temperature	Total Air Volume	Outdoor Air Temperature Entering Outdoor Coil																			
		85°F					95°F					105°F					115°F				
		Total Cool Cap.	Comp. Motor Input	Sensible To Total Ratio (S/T)			Total Cool Cap.	Comp. Motor Input	Sensible To Total Ratio (S/T)			Total Cool Cap.	Comp. Motor Input	Sensible To Total Ratio (S/T)			Total Cool Cap.	Comp. Motor Input	Sensible To Total Ratio (S/T)		
				Dry Bulb					Dry Bulb					Dry Bulb					Dry Bulb		
cfm	kBtuh	kW	75°F	80°F	85°F	kBtuh	kW	75°F	80°F	85°F	kBtuh	kW	75°F	80°F	85°F	kBtuh	kW	75°F	80°F	85°F	
63°F	6400	238.6	14.89	0.71	0.85	0.98	225.8	16.88	0.72	0.87	1	213.7	19.09	0.73	0.89	1	200.8	21.55	0.75	0.91	1
	8000	250.9	14.97	0.77	0.93	1	237.4	17	0.78	0.95	1	224.1	19.22	0.8	0.97	1	211	21.69	0.82	0.99	1
	9600	260.2	15.04	0.82	0.99	1	247.4	17.1	0.84	1	1	235.4	19.36	0.86	1	1	222	21.85	0.88	1	1
67°F	6400	254.3	15	0.56	0.69	0.82	241.8	17.04	0.56	0.7	0.84	228.9	19.28	0.56	0.71	0.86	213.9	21.74	0.57	0.72	0.88
	8000	265.9	15.08	0.59	0.74	0.9	252.1	17.14	0.6	0.76	0.92	238.4	19.39	0.6	0.77	0.94	223.5	21.87	0.61	0.79	0.97
	9600	274.1	15.13	0.62	0.8	0.97	260	17.22	0.63	0.82	0.98	244.7	19.47	0.64	0.84	1	228.9	21.94	0.65	0.86	1
71°F	6400	270.3	15.11	0.42	0.54	0.67	256.8	17.19	0.41	0.54	0.68	243.1	19.45	0.41	0.55	0.69	228.2	21.93	0.4	0.56	0.7
	8000	282	15.18	0.43	0.58	0.72	268.1	17.29	0.43	0.58	0.74	253.4	19.56	0.43	0.59	0.75	237.6	22.05	0.43	0.6	0.77
	9600	290.4	15.24	0.44	0.61	0.78	275.4	17.35	0.44	0.62	0.8	260.3	19.63	0.45	0.63	0.82	243.7	22.12	0.45	0.65	0.84

## 25 TON - LCX300S5M (PART LOAD)

Entering Wet Bulb Temperature	Total Air Volume	Outdoor Air Temperature Entering Outdoor Coil																			
		65°F					75°F					85°F					95°F				
		Total Cool Cap.	Comp. Motor Input	Sensible To Total Ratio (S/T)			Total Cool Cap.	Comp. Motor Input	Sensible To Total Ratio (S/T)			Total Cool Cap.	Comp. Motor Input	Sensible To Total Ratio (S/T)			Total Cool Cap.	Comp. Motor Input	Sensible To Total Ratio (S/T)		
				Dry Bulb					Dry Bulb					Dry Bulb					Dry Bulb		
cfm	kBtuh	kW	75°F	80°F	85°F	kBtuh	kW	75°F	80°F	85°F	kBtuh	kW	75°F	80°F	85°F	kBtuh	kW	75°F	80°F	85°F	
63°F	5750	166.6	6.25	0.77	0.92	1	159	7.15	0.78	0.94	1	150.9	8.15	0.79	0.95	1	142.4	9.28	0.8	0.97	1
	6750	172.5	6.29	0.81	0.97	1	164.7	7.2	0.82	0.98	1	156.3	8.2	0.84	0.99	1	148.1	9.33	0.85	1	1
	7750	177.4	6.33	0.84	0.99	1	169.8	7.24	0.86	1	1	161.2	8.25	0.88	1	1	152.6	9.38	0.9	1	1
67°F	5750	176.7	6.32	0.6	0.75	0.89	168.5	7.23	0.61	0.76	0.91	158.9	8.22	0.61	0.78	0.93	149.9	9.35	0.62	0.79	0.95
	6750	181.2	6.36	0.63	0.79	0.94	172.6	7.27	0.63	0.8	0.96	163.1	8.26	0.64	0.82	0.98	153.9	9.4	0.65	0.83	0.99
	7750	185	6.38	0.65	0.83	0.98	175.6	7.29	0.66	0.84	0.99	166.3	8.29	0.66	0.86	1	156.6	9.43	0.67	0.88	1
71°F	5750	185.1	6.38	0.45	0.59	0.73	176	7.29	0.45	0.6	0.74	167.2	8.3	0.45	0.61	0.76	158.2	9.44	0.44	0.61	0.77
	6750	190.4	6.43	0.46	0.62	0.77	181.2	7.34	0.46	0.63	0.78	172.2	8.35	0.46	0.63	0.8	162.4	9.49	0.46	0.64	0.82
	7750	194.9	6.47	0.48	0.64	0.81	185.1	7.38	0.47	0.65	0.82	175.6	8.39	0.47	0.66	0.84	165.2	9.53	0.47	0.67	0.86

## 25 TON - LCX300S5M (FULL LOAD)

Entering Wet Bulb Temperature	Total Air Volume	Outdoor Air Temperature Entering Outdoor Coil																			
		85°F					95°F					105°F					115°F				
		Total Cool Cap.	Comp. Motor Input	Sensible To Total Ratio (S/T)			Total Cool Cap.	Comp. Motor Input	Sensible To Total Ratio (S/T)			Total Cool Cap.	Comp. Motor Input	Sensible To Total Ratio (S/T)			Total Cool Cap.	Comp. Motor Input	Sensible To Total Ratio (S/T)		
				Dry Bulb					Dry Bulb					Dry Bulb					Dry Bulb		
cfm	kBtuh	kW	75°F	80°F	85°F	kBtuh	kW	75°F	80°F	85°F	kBtuh	kW	75°F	80°F	85°F	kBtuh	kW	75°F	80°F	85°F	
63°F	8000	294.6	17.45	0.7	0.83	0.94	278.2	19.93	0.71	0.85	0.95	262.2	22.71	0.72	0.85	0.97	243.7	25.97	0.73	0.87	0.99
	9500	307.6	17.53	0.75	0.87	0.98	290.3	19.94	0.76	0.89	0.99	272.8	22.69	0.78	0.91	1	254.7	25.91	0.78	0.92	1
	11000	317.2	17.58	0.79	0.91	1	298.8	20.02	0.79	0.93	1	281.3	22.78	0.81	0.95	1	263.6	26.03	0.82	0.97	1
67°F	8000	309.2	17.64	0.53	0.68	0.81	291	19.91	0.54	0.68	0.82	273.3	22.7	0.53	0.69	0.83	254.3	26.19	0.54	0.7	0.84
	9500	319.2	17.69	0.57	0.72	0.85	301.7	20.16	0.57	0.73	0.86	283	22.76	0.57	0.75	0.88	262.5	25.98	0.55	0.77	0.9
	11000	328.7	17.74	0.57	0.76	0.89	309.9	20.19	0.58	0.78	0.91	290.4	22.86	0.58	0.8	0.93	271.1	26.07	0.59	0.8	0.95
71°F	8000	329.8	17.77	0.39	0.52	0.65	311.8	20.21	0.38	0.52	0.65	292.3	22.89	0.38	0.53	0.67	271.7	26.07	0.37	0.52	0.69
	9500	340.7	17.82	0.4	0.55	0.69	321.5	20.31	0.39	0.56	0.71	301.3	23.03	0.39	0.55	0.72	280	26.16	0.39	0.56	0.74
	11000	348.5	17.79	0.41	0.57	0.74	329	20.37	0.41	0.57	0.75	307.9	23.09	0.4	0.58	0.78	285.2	26.22	0.39	0.59	0.79

# HUMIDITROL® DEHUMIDIFICATION SYSTEM RATINGS

NOTE - For Temperatures and Capacities not shown in tables, see bulletin - Cooling Unit Rating Table Correction Factor Data in Miscellaneous Engineering Data section.

## 15 TON - LCX180S5M WITH HUMIDITROL® DEHUMIDIFICATION OPERATING (PART LOAD)

Entering Wet Bulb Temperature	Total Air Volume	Outdoor Air Temperature Entering Outdoor Coil																			
		65°F					75°F					85°F					95°F				
		Total Cool Cap.	Comp. Motor Input	Sensible To Total Ratio (S/T)			Total Cool Cap.	Comp. Motor Input	Sensible To Total Ratio (S/T)			Total Cool Cap.	Comp. Motor Input	Sensible To Total Ratio (S/T)			Total Cool Cap.	Comp. Motor Input	Sensible To Total Ratio (S/T)		
				Dry Bulb					Dry Bulb					Dry Bulb					Dry Bulb		
cfm	kBtuh	kW	75°F	80°F	85°F	kBtuh	kW	75°F	80°F	85°F	kBtuh	kW	75°F	80°F	85°F	kBtuh	kW	75°F	80°F	85°F	
63°F	3500	72.59	4.57	0.54	0.69	0.85	53.64	5.21	0.47	0.69	0.88	35.15	5.86	0.31	0.65	0.93	17.07	6.60	-0.26	0.52	1.00
	4000	75.44	4.61	0.57	0.74	0.89	55.69	5.25	0.50	0.73	0.91	36.13	5.90	0.35	0.71	0.96	16.84	6.64	-0.26	0.64	1.00
	4500	78.05	4.65	0.59	0.78	0.91	57.34	5.28	0.53	0.78	0.94	36.73	5.94	0.38	0.79	1.00	16.41	6.68	-0.26	0.78	1.00
67°F	3500	82.70	4.65	0.41	0.55	0.68	64.04	5.29	0.30	0.49	0.66	45.59	5.94	0.11	0.39	0.64	26.95	6.68	-0.38	0.14	0.56
	4000	86.10	4.69	0.42	0.57	0.71	66.31	5.33	0.32	0.52	0.71	46.67	5.99	0.12	0.42	0.69	26.64	6.72	-0.41	0.17	0.64
	4500	88.82	4.72	0.43	0.60	0.75	68.05	5.36	0.33	0.55	0.75	47.33	6.02	0.12	0.46	0.75	26.49	6.76	-0.45	0.21	0.73
71°F	3500	93.34	4.72	0.29	0.42	0.55	74.66	5.37	0.17	0.35	0.51	56.03	6.03	-0.02	0.22	0.43	37.37	6.77	-0.43	-0.04	0.29
	4000	96.78	4.75	0.29	0.44	0.58	76.88	5.40	0.18	0.37	0.54	57.14	6.06	-0.04	0.23	0.46	36.85	6.80	-0.49	-0.05	0.32
	4500	99.52	4.78	0.30	0.46	0.60	78.69	5.43	0.17	0.38	0.56	57.60	6.09	-0.05	0.25	0.50	36.46	6.83	-0.55	-0.05	0.36

## 15 TON - LCX180S5M WITH HUMIDITROL® DEHUMIDIFICATION OPERATING (FULL LOAD)

Entering Wet Bulb Temperature	Total Air Volume	Outdoor Air Temperature Entering Outdoor Coil																			
		65°F					75°F					85°F					95°F				
		Total Cool Cap.	Comp. Motor Input	Sensible To Total Ratio (S/T)			Total Cool Cap.	Comp. Motor Input	Sensible To Total Ratio (S/T)			Total Cool Cap.	Comp. Motor Input	Sensible To Total Ratio (S/T)			Total Cool Cap.	Comp. Motor Input	Sensible To Total Ratio (S/T)		
				Dry Bulb					Dry Bulb					Dry Bulb					Dry Bulb		
cfm	kBtuh	kW	75°F	80°F	85°F	kBtuh	kW	75°F	80°F	85°F	kBtuh	kW	75°F	80°F	85°F	kBtuh	kW	75°F	80°F	85°F	
63°F	4800	120.72	6.98	0.55	0.75	0.94	96.51	8.10	0.50	0.75	0.98	72.52	9.22	0.41	0.75	1.00	48.73	10.42	0.24	0.74	1.00
	6000	127.64	7.04	0.61	0.85	1.00	101.51	8.16	0.58	0.87	1.00	75.20	9.29	0.52	0.90	1.00	48.74	10.48	0.38	0.98	1.00
	7200	132.55	7.09	0.68	0.93	0.99	104.64	8.21	0.66	0.97	1.00	77.12	9.34	0.62	1.00	1.00	50.48	10.54	0.54	1.00	1.00
67°F	4800	137.03	7.06	0.36	0.54	0.71	112.56	8.18	0.28	0.50	0.71	88.36	9.31	0.15	0.43	0.70	63.84	10.50	-0.08	0.32	0.69
	6000	144.54	7.12	0.40	0.61	0.81	117.97	8.24	0.32	0.58	0.82	91.14	9.36	0.20	0.53	0.84	64.72	10.56	-0.04	0.44	0.87
	7200	149.26	7.15	0.43	0.67	0.89	120.92	8.28	0.36	0.65	0.92	92.52	9.41	0.24	0.62	0.97	63.93	10.60	0.01	0.57	1.00
71°F	4800	152.82	7.13	0.21	0.37	0.53	128.39	8.25	0.11	0.31	0.49	103.94	9.38	-0.04	0.21	0.44	79.49	10.58	-0.28	0.05	0.36
	6000	161.14	7.18	0.22	0.41	0.60	134.13	8.31	0.12	0.35	0.57	107.35	9.44	-0.03	0.26	0.53	80.79	10.64	-0.30	0.11	0.47
	7200	166.14	7.22	0.22	0.45	0.66	137.10	8.34	0.12	0.39	0.64	108.70	9.47	-0.04	0.31	0.62	80.31	10.68	-0.32	0.16	0.58

## 17.5 TON - LCX210S5M WITH HUMIDITROL® DEHUMIDIFICATION OPERATING (PART LOAD)

Entering Wet Bulb Temperature	Total Air Volume	Outdoor Air Temperature Entering Outdoor Coil																			
		65°F					75°F					85°F					95°F				
		Total Cool Cap.	Comp. Motor Input	Sensible To Total Ratio (S/T)			Total Cool Cap.	Comp. Motor Input	Sensible To Total Ratio (S/T)			Total Cool Cap.	Comp. Motor Input	Sensible To Total Ratio (S/T)			Total Cool Cap.	Comp. Motor Input	Sensible To Total Ratio (S/T)		
				Dry Bulb					Dry Bulb					Dry Bulb					Dry Bulb		
cfm	kBtuh	kW	75°F	80°F	85°F	kBtuh	kW	75°F	80°F	85°F	kBtuh	kW	75°F	80°F	85°F	kBtuh	kW	75°F	80°F	85°F	
63°F	4000	81.12	6.32	0.52	0.67	0.81	58.39	6.92	0.40	0.61	0.81	36.56	7.64	0.14	0.51	0.79	15.31	8.53	-0.99	0.10	0.73
	4750	87.60	6.44	0.57	0.73	0.85	63.72	7.05	0.48	0.70	0.85	40.94	7.78	0.27	0.65	0.86	19.06	8.67	-0.45	0.48	0.86
	5500	92.28	6.54	0.61	0.78	0.88	67.89	7.15	0.53	0.78	0.88	44.46	7.88	0.38	0.76	0.88	22.33	8.78	-0.11	0.67	0.87
67°F	4000	93.54	6.49	0.40	0.54	0.66	70.79	7.10	0.27	0.45	0.62	48.53	7.84	0.01	0.30	0.55	27.58	8.74	-0.67	-0.07	0.39
	4750	99.88	6.61	0.43	0.58	0.72	76.35	7.23	0.32	0.52	0.70	52.97	7.96	0.10	0.40	0.66	31.04	8.87	-0.44	0.12	0.58
	5500	104.67	6.71	0.47	0.62	0.77	80.09	7.33	0.36	0.57	0.76	56.57	8.08	0.16	0.47	0.75	33.78	8.98	-0.30	0.26	0.72
71°F	4000	105.27	6.65	0.29	0.43	0.55	82.95	7.28	0.17	0.34	0.49	60.06	8.02	-0.09	0.17	0.39	39.01	8.93	-0.57	-0.16	0.19
	4750	111.93	6.78	0.32	0.46	0.59	88.05	7.41	0.19	0.38	0.54	64.84	8.16	-0.01	0.23	0.46	43.44	9.08	-0.44	-0.04	0.31
	5500	116.44	6.88	0.34	0.49	0.63	92.65	7.52	0.22	0.42	0.59	68.58	8.27	0.02	0.29	0.52	45.75	9.18	-0.37	0.04	0.41

## 17.5 TON - LCX210S5M WITH HUMIDITROL® DEHUMIDIFICATION OPERATING (FULL LOAD)

Entering Wet Bulb Temperature	Total Air Volume	Outdoor Air Temperature Entering Outdoor Coil																			
		65°F					75°F					85°F					95°F				
		Total Cool Cap.	Comp. Motor Input	Sensible To Total Ratio (S/T)			Total Cool Cap.	Comp. Motor Input	Sensible To Total Ratio (S/T)			Total Cool Cap.	Comp. Motor Input	Sensible To Total Ratio (S/T)			Total Cool Cap.	Comp. Motor Input	Sensible To Total Ratio (S/T)		
				Dry Bulb					Dry Bulb					Dry Bulb					Dry Bulb		
cfm	kBtuh	kW	75°F	80°F	85°F	kBtuh	kW	75°F	80°F	85°F	kBtuh	kW	75°F	80°F	85°F	kBtuh	kW	75°F	80°F	85°F	
63°F	5600	144.60	9.52	0.54	0.73	0.92	114.40	10.52	0.49	0.74	0.98	83.79	11.69	0.40	0.75	1.00	55.02	13.11	0.22	0.77	1.00
	7000	151.95	9.73	0.60	0.83	0.98	119.89	10.74	0.57	0.87	1.00	87.25	11.91	0.51	0.93	1.00	56.13	13.33	0.40	1.00	1.00
	8400	158.17	9.88	0.67	0.93	0.98	124.87	10.91	0.66	0.98	1.00	92.42	12.12	0.64	1.00	1.00	61.14	13.56	0.60	1.00	1.00
67°F	5600	164.88	9.79	0.35	0.52	0.70	134.57	10.82	0.26	0.49	0.70	103.68	12.00	0.13	0.42	0.70	74.12	13.42	-0.09	0.32	0.70
	7000	172.24	10.00	0.39	0.59	0.80	139.95	11.03	0.30	0.56	0.81	106.72	12.21	0.19	0.53	0.85	75.47	13.65	-0.03	0.45	0.90
	8400	177.60	10.14	0.42	0.66	0.89	144.10	11.19	0.35	0.65	0.92	109.15	12.37	0.24	0.64	0.98	75.85	13.79	0.04	0.61	1.00
71°F	5600	184.72	10.06	0.20	0.36	0.51	154.48	11.11	0.09	0.29	0.48	123.04	12.30	-0.05	0.20	0.43	93.34	13.74	-0.31	0.04	0.36
	7000	192.57	10.28	0.20	0.40	0.58	159.28	11.31	0.10	0.34	0.56	126.77	12.53	-0.05	0.25	0.53	94.88	13.96	-0.30	0.10	0.47
	8400	196.74	10.41	0.21	0.43	0.64	163.27	11.47	0.11	0.38	0.64	129.32	12.69	-0.04	0.31	0.62	96.15	14.13	-0.30	0.18	0.60

# HUMIDITROL® DEHUMIDIFICATION SYSTEM RATINGS

NOTE - For Temperatures and Capacities not shown in tables, see bulletin - Cooling Unit Rating Table Correction Factor Data in Miscellaneous Engineering Data section.

## 20 TON - LCX240S5M WITH HUMIDITROL® DEHUMIDIFICATION OPERATING (PART LOAD)

Entering Wet Bulb Temperature	Total Air Volume	Outdoor Air Temperature Entering Outdoor Coil																			
		65°F					75°F					85°F					95°F				
		Total Cool Cap.	Comp. Motor Input	Sensible To Total Ratio (S/T)			Total Cool Cap.	Comp. Motor Input	Sensible To Total Ratio (S/T)			Total Cool Cap.	Comp. Motor Input	Sensible To Total Ratio (S/T)			Total Cool Cap.	Comp. Motor Input	Sensible To Total Ratio (S/T)		
				Dry Bulb					Dry Bulb					Dry Bulb					Dry Bulb		
cfm	kBtuh	kW	75°F	80°F	85°F	kBtuh	kW	75°F	80°F	85°F	kBtuh	kW	75°F	80°F	85°F	kBtuh	kW	75°F	80°F	85°F	
63°F	4500	96.79	7.72	0.55	0.69	0.82	73.46	8.51	0.48	0.67	0.83	50.63	9.39	0.35	0.63	0.85	28.35	10.40	-0.02	0.51	0.86
	5500	103.40	7.78	0.59	0.74	0.86	77.99	8.60	0.54	0.74	0.87	53.10	9.49	0.41	0.73	0.89	28.11	10.51	0.06	0.68	0.91
	6500	108.13	7.82	0.63	0.80	0.88	81.43	8.65	0.58	0.81	0.88	54.97	9.57	0.48	0.81	0.89	29.03	10.60	0.15	0.78	0.89
67°F	4500	110.57	7.80	0.43	0.56	0.68	87.35	8.62	0.35	0.51	0.66	64.28	9.52	0.20	0.43	0.63	41.48	10.55	-0.14	0.24	0.56
	5500	117.63	7.85	0.46	0.60	0.73	92.37	8.69	0.38	0.56	0.73	66.66	9.61	0.22	0.48	0.71	41.93	10.66	-0.13	0.31	0.68
	6500	122.65	7.87	0.48	0.64	0.78	95.38	8.74	0.40	0.60	0.79	68.39	9.67	0.25	0.54	0.79	41.69	10.73	-0.13	0.38	0.79
71°F	4500	123.86	7.87	0.33	0.46	0.57	100.70	8.71	0.23	0.39	0.53	77.36	9.64	0.08	0.29	0.47	54.51	10.69	-0.22	0.09	0.35
	5500	131.52	7.90	0.35	0.48	0.60	106.29	8.78	0.25	0.42	0.57	80.40	9.72	0.09	0.32	0.52	55.27	10.79	-0.25	0.11	0.41
	6500	136.61	7.93	0.36	0.51	0.64	109.53	8.81	0.26	0.45	0.61	82.88	9.79	0.09	0.35	0.57	55.84	10.86	-0.26	0.14	0.48

## 20 TON - LCX240S5M WITH HUMIDITROL® DEHUMIDIFICATION OPERATING (FULL LOAD)

Entering Wet Bulb Temperature	Total Air Volume	Outdoor Air Temperature Entering Outdoor Coil																			
		65°F					75°F					85°F					95°F				
		Total Cool Cap.	Comp. Motor Input	Sensible To Total Ratio (S/T)			Total Cool Cap.	Comp. Motor Input	Sensible To Total Ratio (S/T)			Total Cool Cap.	Comp. Motor Input	Sensible To Total Ratio (S/T)			Total Cool Cap.	Comp. Motor Input	Sensible To Total Ratio (S/T)		
				Dry Bulb					Dry Bulb					Dry Bulb					Dry Bulb		
cfm	kBtuh	kW	75°F	80°F	85°F	kBtuh	kW	75°F	80°F	85°F	kBtuh	kW	75°F	80°F	85°F	kBtuh	kW	75°F	80°F	85°F	
63°F	6400	168.32	11.65	0.57	0.77	0.95	137.65	12.99	0.54	0.77	1.00	107.51	14.46	0.48	0.79	1.00	77.36	16.11	0.39	0.82	1.00
	8000	178.04	11.74	0.64	0.86	1.00	144.61	13.12	0.61	0.89	1.00	111.58	14.61	0.58	0.94	1.00	79.37	16.29	0.52	1.00	1.00
	9600	185.73	11.80	0.70	0.95	1.00	150.80	13.21	0.70	0.99	1.00	116.30	14.73	0.69	1.00	1.00	83.70	16.45	0.67	1.00	1.00
67°F	6400	191.38	11.77	0.38	0.56	0.73	160.15	13.15	0.32	0.53	0.73	128.82	14.66	0.22	0.49	0.73	99.11	16.36	0.07	0.42	0.74
	8000	201.44	11.84	0.42	0.62	0.82	167.74	13.27	0.36	0.60	0.84	133.46	14.81	0.27	0.57	0.87	101.63	16.53	0.12	0.53	0.92
	9600	208.39	11.89	0.45	0.69	0.91	173.09	13.34	0.40	0.68	0.94	137.19	14.91	0.32	0.67	0.99	102.75	16.65	0.19	0.66	1.00
71°F	6400	213.96	11.87	0.23	0.39	0.54	182.74	13.31	0.15	0.33	0.52	150.78	14.86	0.03	0.26	0.48	120.99	16.60	-0.13	0.16	0.43
	8000	224.27	11.93	0.24	0.43	0.61	189.88	13.41	0.15	0.38	0.59	156.27	15.00	0.04	0.31	0.57	123.59	16.77	-0.13	0.21	0.54
	9600	231.20	11.97	0.25	0.47	0.67	195.38	13.48	0.17	0.43	0.66	160.30	15.10	0.05	0.37	0.66	124.56	16.77	-0.13	0.27	0.65

## 25 TON - LCX300S5M WITH HUMIDITROL® DEHUMIDIFICATION OPERATING (PART LOAD)

Entering Wet Bulb Temperature	Total Air Volume	Outdoor Air Temperature Entering Outdoor Coil																			
		65°F					75°F					85°F					95°F				
		Total Cool Cap.	Comp. Motor Input	Sensible To Total Ratio (S/T)			Total Cool Cap.	Comp. Motor Input	Sensible To Total Ratio (S/T)			Total Cool Cap.	Comp. Motor Input	Sensible To Total Ratio (S/T)			Total Cool Cap.	Comp. Motor Input	Sensible To Total Ratio (S/T)		
				Dry Bulb					Dry Bulb					Dry Bulb					Dry Bulb		
cfm	kBtuh	kW	75°F	80°F	85°F	kBtuh	kW	75°F	80°F	85°F	kBtuh	kW	75°F	80°F	85°F	kBtuh	kW	75°F	80°F	85°F	
63°F	5750	85.82	6.39	0.69	0.97	1.00	63.38	6.97	0.62	1.00	1.00	40.76	7.62	0.47	1.00	1.00	17.68	8.47	-0.20	1.00	1.00
	6750	90.76	6.49	0.76	1.00	1.00	66.41	7.06	0.71	1.00	1.00	42.69	7.71	0.61	1.00	1.00	19.21	8.58	0.08	1.00	1.00
	7750	95.53	6.56	0.82	1.00	1.00	70.53	7.11	0.80	1.00	1.00	45.92	7.81	0.75	1.00	1.00	21.07	8.59	0.46	1.00	1.00
67°F	5750	99.33	6.54	0.43	0.68	0.92	76.24	7.09	0.29	0.63	0.93	52.77	7.76	0.04	0.53	0.97	29.91	8.55	-0.70	0.29	1.00
	6750	103.38	6.62	0.47	0.74	0.99	78.80	7.16	0.34	0.71	1.00	53.94	7.84	0.08	0.64	1.00	28.92	8.62	-0.69	0.46	1.00
	7750	106.98	6.67	0.51	0.80	1.00	80.48	7.22	0.39	0.79	1.00	54.47	7.90	0.13	0.75	1.00	27.95	8.68	-0.65	0.65	1.00
71°F	5750	112.29	6.68	0.22	0.45	0.67	89.05	7.23	0.05	0.35	0.63	65.59	7.91	-0.24	0.19	0.56	42.17	8.70	-0.90	-0.17	0.42
	6750	116.80	6.76	0.25	0.50	0.73	91.81	7.30	0.07	0.40	0.70	67.11	7.98	-0.25	0.24	0.66	41.68	8.78	-0.97	-0.12	0.55
	7750	120.70	6.81	0.27	0.53	0.78	94.30	7.36	0.10	0.44	0.77	68.13	8.05	-0.21	0.30	0.74	41.10	8.83	-0.99	-0.05	0.69

## 25 TON - LCX300S5M WITH HUMIDITROL® DEHUMIDIFICATION OPERATING (FULL LOAD)

Entering Wet Bulb Temperature	Total Air Volume	Outdoor Air Temperature Entering Outdoor Coil																			
		65°F					75°F					85°F					95°F				
		Total Cool Cap.	Comp. Motor Input	Sensible To Total Ratio (S/T)			Total Cool Cap.	Comp. Motor Input	Sensible To Total Ratio (S/T)			Total Cool Cap.	Comp. Motor Input	Sensible To Total Ratio (S/T)			Total Cool Cap.	Comp. Motor Input	Sensible To Total Ratio (S/T)		
				Dry Bulb					Dry Bulb					Dry Bulb					Dry Bulb		
cfm	kBtuh	kW	75°F	80°F	85°F	kBtuh	kW	75°F	80°F	85°F	kBtuh	kW	75°F	80°F	85°F	kBtuh	kW	75°F	80°F	85°F	
63°F	8000	212.97	13.23	0.62	0.83	0.95	181.79	14.73	0.59	0.82	0.98	149.47	16.46	0.59	0.83	1.00	116.66	18.45	0.55	0.86	1.00
	9500	221.32	13.37	0.66	0.86	1.00	185.85	14.88	0.65	0.88	1.00	150.35	16.58	0.64	0.90	1.00	113.28	18.63	0.60	0.94	1.00
	11000	228.63	13.49	0.71	0.91	1.00	189.97	15.01	0.71	0.93	1.00	150.35	16.72	0.72	0.96	1.00	110.10	18.70	0.67	1.00	1.00
67°F	8000	237.60	13.40	0.42	0.60	0.78	205.06	14.92	0.37	0.58	0.79	171.98	16.71	0.31	0.55	0.79	137.39	18.56	0.22	0.52	0.80
	9500	245.51	13.51	0.45	0.64	0.82	209.15	15.02	0.40	0.62	0.83	171.79	16.83	0.34	0.61	0.85	134.31	18.74	0.20	0.59	0.87
	11000	251.75	13.58	0.47	0.68	0.87	212.86	15.13	0.41	0.69	0.89	172.14	16.94	0.33	0.67	0.91	131.18	18.94	0.23	0.67	0.95
71°F	8000	264.05	13.60	0.26	0.43	0.58	230.83	15.15	0.20	0.39	0.57	196.57	16.87	0.12	0.34	0.54	162.03	18.98	0.01	0.25	0.50
	9500	272.96	13.72	0.26	0.44	0.62	236.36	15.27	0.20	0.41	0.60	198.53	17.01	0.11	0.33	0.58	159.20	19.13	-0.04	0.25	0.58
	11000	280.11	13.81	0.26	0.46	0.67	239.88	15.38	0.19	0.42	0.65	199.83	17.12	0.10	0.37	0.65	157.05	19.20	-0.05	0.29	0.63

## BLOWER DATA

### BLOWER TABLE INCLUDES RESISTANCE FOR BASE UNIT ONLY WITH DRY INDOOR COIL & AIR FILTERS IN PLACE

FOR ALL UNITS ADD:

- 1 - Wet indoor coil air resistance of selected unit.
- 2 - Any factory installed options air resistance (electric heat, economizer, etc.)
- 3 - Any field installed accessories air resistance (electric heat, duct resistance, diffuser, etc.)

Then determine from blower table blower motor output and drive required.

See page 29 for wet coil, option/accessory air resistance data, and factory installed drive kit specifications.

See page 30 for minimum air volume required for use with optional electric heat.

Air Volume cfm	TOTAL STATIC PRESSURE - Inches Water Gauge (Pa)																																																																																																																																																																																																																																																																																																																																																																																																																																																																																																																																																																																																																																																																																																																																																																																																																																																																																																																																																																																																																																																																																																																																																																																																								
	0.20		0.40		0.60		0.80		1.00		1.20		1.40		1.60		1.80		2.00		2.20		2.40		2.60																																																																																																																																																																																																																																																																																																																																																																																																																																																																																																																																																																																																																																																																																																																																																																																																																																																																																																																																																																																																																																																																																																																																																																																
	RPM	BHP	RPM	BHP	RPM	BHP	RPM	BHP	RPM	BHP	RPM	BHP	RPM	BHP	RPM	BHP	RPM	BHP	RPM	BHP	RPM	BHP	RPM	BHP	RPM	BHP	RPM	BHP																																																																																																																																																																																																																																																																																																																																																																																																																																																																																																																																																																																																																																																																																																																																																																																																																																																																																																																																																																																																																																																																																																																																																																													
2750	385	0.30	505	0.50	600	0.70	680	0.90	755	1.10	820	1.30	885	1.50	950	1.70	1015	1.90	1080	2.10	1145	2.30	1210	2.50	1275	2.70	1340	2.90	1405	3.10	1470	3.30	1535	3.50	1600	3.70	1665	3.90	1730	4.10	1795	4.30	1860	4.50	1925	4.70	1990	4.90	2055	5.10	2120	5.30	2185	5.50	2250	5.70	2315	5.90	2380	6.10	2445	6.30	2510	6.50	2575	6.70	2640	6.90	2705	7.10	2770	7.30	2835	7.50	2900	7.70	2965	7.90	3030	8.10	3095	8.30	3160	8.50	3225	8.70	3290	8.90	3355	9.10	3420	9.30	3485	9.50	3550	9.70	3615	9.90	3680	10.10	3745	10.30	3810	10.50	3875	10.70	3940	10.90	4005	11.10	4070	11.30	4135	11.50	4200	11.70	4265	11.90	4330	12.10	4395	12.30	4460	12.50	4525	12.70	4590	12.90	4655	13.10	4720	13.30	4785	13.50	4850	13.70	4915	13.90	4980	14.10	5045	14.30	5110	14.50	5175	14.70	5240	14.90	5305	15.10	5370	15.30	5435	15.50	5500	15.70	5565	15.90	5630	16.10	5695	16.30	5760	16.50	5825	16.70	5890	16.90	5955	17.10	6020	17.30	6085	17.50	6150	17.70	6215	17.90	6280	18.10	6345	18.30	6410	18.50	6475	18.70	6540	18.90	6605	19.10	6670	19.30	6735	19.50	6800	19.70	6865	19.90	6930	20.10	6995	20.30	7060	20.50	7125	20.70	7190	20.90	7255	21.10	7320	21.30	7385	21.50	7450	21.70	7515	21.90	7580	22.10	7645	22.30	7710	22.50	7775	22.70	7840	22.90	7905	23.10	7970	23.30	8035	23.50	8100	23.70	8165	23.90	8230	24.10	8295	24.30	8360	24.50	8425	24.70	8490	24.90	8555	25.10	8620	25.30	8685	25.50	8750	25.70	8815	25.90	8880	26.10	8945	26.30	9010	26.50	9075	26.70	9140	26.90	9205	27.10	9270	27.30	9335	27.50	9400	27.70	9465	27.90	9530	28.10	9595	28.30	9660	28.50	9725	28.70	9790	28.90	9855	29.10	9920	29.30	9985	29.50	10050	29.70	10115	29.90	10180	30.10	10245	30.30	10310	30.50	10375	30.70	10440	30.90	10505	31.10	10570	31.30	10635	31.50	10700	31.70	10765	31.90	10830	32.10	10895	32.30	10960	32.50	11025	32.70	11090	32.90	11155	33.10	11220	33.30	11285	33.50	11350	33.70	11415	33.90	11480	34.10	11545	34.30	11610	34.50	11675	34.70	11740	34.90	11805	35.10	11870	35.30	11935	35.50	12000	35.70	12065	35.90	12130	36.10	12195	36.30	12260	36.50	12325	36.70	12390	36.90	12455	37.10	12520	37.30	12585	37.50	12650	37.70	12715	37.90	12780	38.10	12845	38.30	12910	38.50	12975	38.70	13040	38.90	13105	39.10	13170	39.30	13235	39.50	13300	39.70	13365	39.90	13430	40.10	13495	40.30	13560	40.50	13625	40.70	13690	40.90	13755	41.10	13820	41.30	13885	41.50	13950	41.70	14015	41.90	14080	42.10	14145	42.30	14210	42.50	14275	42.70	14340	42.90	14405	43.10	14470	43.30	14535	43.50	14600	43.70	14665	43.90	14730	44.10	14795	44.30	14860	44.50	14925	44.70	14990	44.90	15055	45.10	15120	45.30	15185	45.50	15250	45.70	15315	45.90	15380	46.10	15445	46.30	15510	46.50	15575	46.70	15640	46.90	15705	47.10	15770	47.30	15835	47.50	15900	47.70	15965	47.90	16030	48.10	16095	48.30	16160	48.50	16225	48.70	16290	48.90	16355	49.10	16420	49.30	16485	49.50	16550	49.70	16615	49.90	16680	50.10	16745	50.30	16810	50.50	16875	50.70	16940	50.90	17005	51.10	17070	51.30	17135	51.50	17200	51.70	17265	51.90	17330	52.10	17395	52.30	17460	52.50	17525	52.70	17590	52.90	17655	53.10	17720	53.30	17785	53.50	17850	53.70	17915	53.90	17980	54.10	18045	54.30	18110	54.50	18175	54.70	18240	54.90	18305	55.10	18370	55.30	18435	55.50	18500	55.70	18565	55.90	18630	56.10	18695	56.30	18760	56.50	18825	56.70	18890	56.90	18955	57.10	19020	57.30	19085	57.50	19150	57.70	19215	57.90	19280	58.10	19345	58.30	19410	58.50	19475	58.70	19540	58.90	19605	59.10	19670	59.30	19735	59.50	19800	59.70	19865	59.90	19930	60.10	19995	60.30	20060	60.50	20125	60.70	20190	60.90	20255	61.10	20320	61.30	20385	61.50	20450	61.70	20515	61.90	20580	62.10	20645	62.30	20710	62.50	20775	62.70	20840	62.90	20905	63.10	20970	63.30	21035	63.50	21100	63.70	21165	63.90	21230	64.10	21295	64.30	21360	64.50	21425	64.70	21490	64.90	21555	65.10	21620	65.30	21685	65.50	21750	65.70	21815	65.90	21880	66.10	21945	66.30	22010	66.50	22075	66.70	22140	66.90	22205	67.10	22270	67.30	22335	67.50	22400	67.70	22465	67.90	22530	68.10	22595	68.30	22660	68.50	22725	68.70	22790	68.90	22855	69.10	22920	69.30	22985	69.50	23050	69.70	23115	69.90	23180	70.10	23245	70.30	23310	70.50	23375	70.70	23440	70.90	23505	71.10	23570	71.30	23635	71.50	23700	71.70	23765	71.90	23830	72.10	23895	72.30	23960	72.50	24025	72.70	24090	72.90	24155	73.10	24220	73.30	24285	73.50	24350	73.70	24415	73.90	24480	74.10	24545	74.30	24610	74.50	24675	74.70	24740	74.90	24805	75.10	24870	75.30	24935	75.50	25000	75.70	25065	75.90	25130	76.10	25195	76.30	25260	76.50	25325	76.70	25390	76.90	25455	77.10	25520	77.30	25585	77.50	25650	77.70	25715	77.90	25780	78.10	25845	78.30	25910	78.50	25975	78.70	26040	78.90	26105	79.10	26170	79.30	26235	79.50	26300	79.70	26365	79.90	26430	80.10	26495	80.30	26560	80.50	26625	80.70	26690	80.90	26755	81.10	26820	81.30	26885	81.50	26950	81.70	27015	81.90	27080	82.10	27145	82.30	27210	82.50	27275	82.70	27340	82.90	27405	83.10	27470	83.30	27535	83.50	27600	83.70	27665	83.90	27730	84.10	27795	84.30	27860	84.50	27925	84.70	27990	84.90	28055	85.10	28120	85.30	28185	85.50	28250	85.70	28315	85.90	28380	86.10	28445	86.30	28510	86.50	28575	86.70	28640	86.90	28705	87.10	28770	87.30	28835	87.50	28900	87.70	28965	87.90	29030	88.10	29095	88.30	29160	88.50	29225	88.70	29290	88.90	29355	89.10	29420	89.30	29485	89.50	29550	89.70	29615	89.90	29680	90.10	29745	90.30	29810	90.50	29875	90.70	29940	90.90	30005	91.10	30070	91.30	30135	91.50	30200	91.70	30265	91.90	30330	92.10	30395	92.30	30460	92.50	30525	92.70	30590	92.90	30655	93.10	30720	93.30	30785	93.50	30850	93.70	30915	93.90	30980	94.10	31045	94.30	31110	94.50	31175	94.70	31240	94.90	31305	95.10	31370	95.30	31435	95.50	31500	95.70	31565	95.90	31630	96.10	31695	96.30	31760	96.50	31825	96.70	31890	96.90	31955	97.10	32020	97.30	32085	97.50	32150	97.70	32215	97.90	32280	98.10	32345	98.30	32410	98.50	32475	98.70	32540	98.90	32605	99.10	32670	99.30	32735	99.50	32800	99.70	32865	99.90	32930	100.10	32995	100.30	33060	100.50	33125	100.70	33190	100.90	33255	101.10	33320	101.30	33385	101.50	33450	101.70	33515	101.90	33580	102.10	33645	102.30	33710	102.50	33775	102.70	33840	102.90	33905	103.10	33970	103.30	34035	103.50	34100	103.70	34165	103.90	34230	104.10	34295	104.30	34360	104.50	34425	104.70	34490	104.90	34555	105.10	34620	105.30	34685	105.50	34750	105.70	34815	105.90	34880	106.10	34945	106.30	35010	106.50	35075	106.70	35140	106.90	35205	107.10	35270	107.30	35335	107.50	35400	107.70	35465	107.90	35530	108.10	35595	108.30	35660	108.50	35725	108.70	35790	108.90	35855	109.10	35920	109.30	35985	109.50	36050	109.70	36115	109.90	36180	110.10	36245	110.30	36310	110.50	36375	110.70	36440	110.90	36505	111.10	36570	111.30	36635	111.50	36700	111.70	36765	111.90	36830	112.10	36895	112.30	36960	112.50	37025	112.70	37090	112.90	37155	113.10	37220	113.30	37285	113.50	37350	113.70	37415	113.90	37480	114.10	37545	114.30	37610	114.50	37675	114.70	37740	114.90	37805	115.10	37870	115.30	37935	115.50	38000	115.70	38065	115.90	38130	116.10	

## BLOWER DATA

### FACTORY INSTALLED BELT DRIVE KIT SPECIFICATIONS

Nominal HP	Maximum HP	Drive Kit Number	RPM Range
3	3.45	1	535 - 725
3	3.45	2	710 - 965
5	5.75	3	685 - 856
5	5.75	4	850 - 1045
5	5.75	5	945 - 1185
7.5	8.63	6	850 - 1045
7.5	8.63	7	945 - 1185
7.5	8.63	8	1045 - 1285
10	11.50	7	945 - 1185
10	11.50	10	1045 - 1285
10	11.50	11	1135 - 1330

NOTE - Using total air volume and system static pressure requirements determine from blower performance tables rpm and motor output required. Maximum usable output of motors furnished are shown. In Canada, nominal motor output is also maximum usable motor output. If motors of comparable output are used, be sure to keep within the service factor limitations outlined on the motor nameplate.

NOTE - Motor service factor limit - 1.0.

### FACTORY INSTALLED OPTIONS/FIELD INSTALLED ACCESSORY AIR RESISTANCE - in w.g.

Air Volume cfm	Wet Indoor Coil		Reheat Coil	Electric Heat	Economizer	Filters			Horizontal Roof Curb	
	180	210 240 300				MERV 8	MERV 13	MERV 16	180 thru 240	300
2750	.01	.02	.01	---	---	.01	.03	.06	.03	---
3000	.01	.02	.01	---	---	.01	.03	.06	.04	---
3250	.01	.03	.01	---	---	.01	.04	.07	.04	.01
3500	.01	.03	.02	---	---	.01	.04	.08	.05	.01
3750	.01	.03	.02	---	---	.01	.04	.08	.05	.01
4000	.02	.04	.02	---	---	.01	.04	.09	.06	.02
4250	.02	.04	.02	---	---	.01	.05	.10	.07	.02
4500	.02	.05	.02	---	---	.01	.05	.10	.07	.02
4750	.02	.05	.02	---	---	.02	.05	.11	.08	.03
5000	.02	.05	.02	---	---	.02	.06	.12	.08	.03
5250	.02	.06	.03	---	---	.02	.06	.12	.09	.04
5500	.02	.07	.03	---	---	.02	.06	.13	.10	.04
5750	.03	.07	.03	---	---	.02	.07	.14	.11	.05
6000	.03	.08	.03	.01	---	.03	.07	.14	.11	.06
6250	.03	.08	.03	.01	.01	.03	.07	.15	.12	.07
6500	.03	.09	.04	.01	.02	.03	.08	.16	.13	.08
6750	.04	.10	.04	.01	.03	.03	.08	.17	.14	.08
7000	.04	.10	.04	.01	.04	.04	.08	.17	.15	.09
7250	.04	.11	.04	.01	.05	.04	.09	.18	.16	.10
7500	.05	.12	.05	.01	.06	.04	.09	.19	.17	.11
8000	.05	.13	.05	.02	.09	.05	.10	.21	.19	.13
8500	.06	.15	.05	.02	.11	.05	.10	.22	.21	.15
9000	.07	.16	.06	.04	.14	.06	.11	.24	.24	.17
9500	.08	.18	.07	.05	.16	.07	.12	.25	.26	.19
10,000	.08	.20	.07	.06	.19	.07	.12	.27	.29	.21
10,500	.09	.22	.08	.09	.22	.08	.13	.29	.31	.24
11,000	.11	.24	.08	.11	.25	.09	.14	.30	.34	.27

## BLOWER DATA

### MINIMUM AIR VOLUME REQUIRED FOR USE WITH OPTIONAL ELECTRIC HEAT

Electric Heat kW	Minimum cfm
15	5200
30	5200
45	5200
60	5200
90	6000

### POWER EXHAUST FAN PERFORMANCE

Return Air System Static Pressure	Air Volume Exhausted
in. w.g.	cfm
0.00	8630
0.05	8210
0.10	7725
0.15	7110
0.20	6470
0.25	5790
0.30	5060
0.35	4300
0.40	3510
0.45	2690
0.50	1840

### CEILING DIFFUSER AIR RESISTANCE - in. w.g.

Air Volume cfm	Step-Down Diffuser						Flush Diffuser	
	RTD11-185S			RTD11-275S			FD11-185S	FD11-275S
	2 Ends Open	1 Side/2 Ends Open	All Ends & Sides Open	2 Ends Open	1 Side/2 Ends Open	All Ends & Sides Open		
5000	.51	.44	.39	---	---	---	.27	---
5200	.56	.48	.42	---	---	---	.30	---
5400	.61	.52	.45	---	---	---	.33	---
5600	.66	.56	.48	---	---	---	.36	---
5800	.71	.59	.51	---	---	---	.39	---
6000	.76	.63	.55	.36	.31	.27	.42	.29
6200	.80	.68	.59	---	---	---	.46	---
6400	.86	.72	.63	---	---	---	.50	---
6500	---	---	---	.42	.36	.31	---	.34
6600	.92	.77	.67	---	---	---	.54	---
6800	.99	.83	.72	---	---	---	.58	---
7000	1.03	.87	.76	.49	.41	.36	.62	.40
7200	1.09	.92	.80	---	---	---	.66	---
7400	1.15	.97	.84	---	---	---	.70	---
7500	---	---	---	.51	.46	.41	---	.45
7600	1.20	1.02	.88	---	---	---	.74	---
8000	---	---	---	.59	.49	.43	---	.50
8500	---	---	---	.69	.58	.50	---	.57
9000	---	---	---	.79	.67	.58	---	.66
9500	---	---	---	.89	.75	.65	---	.74
10,000	---	---	---	1.00	.84	.73	---	.81
10,500	---	---	---	1.10	.92	.80	---	.89
11,000	---	---	---	1.21	1.01	.88	---	.96

### CEILING DIFFUSER AIR THROW DATA

Size	Air Volume cfm	<sup>1</sup> Effective Throw Range - ft.		Size	Air Volume cfm	<sup>1</sup> Effective Throw Range - ft.	
		RTD11-185S Step-Down	FD11-185S Flush			RTD11-275S Step-Down	FD11-275S Flush
180	5600	39 - 49	28 - 37	210 240 300	7200	33 - 38	26 - 35
	5800	42 - 51	29 - 38		7400	35 - 40	28 - 37
	6000	44 - 54	40 - 50		7600	36 - 41	29 - 38
	6200	45 - 55	42 - 51		7800	38 - 43	40 - 50
	6400	46 - 55	43 - 52		8000	39 - 44	42 - 51
	6600	47 - 56	45 - 56		8200	41 - 46	43 - 52
					8400	43 - 49	44 - 54
					8600	44 - 50	46 - 57
					8800	47 - 55	48 - 59

<sup>1</sup> Throw is the horizontal or vertical distance an airstream travels on leaving the outlet or diffuser before the maximum velocity is reduced to 50 ft. per minute. Four sides open.

**ELECTRICAL/ELECTRIC HEAT DATA**

**15 TON**

Model		LCX180S5								
<sup>1</sup> Voltage - 60Hz		208/230V - 3 Ph			460V - 3 Ph			575V - 3 Ph		
Compressor 1 (Non-Inverter)	Rated Load Amps	13.1			6.6			4.8		
	Locked Rotor Amps	93			60			41		
Compressor 2 (Non-Inverter)	Rated Load Amps	13.1			6.6			4.8		
	Locked Rotor Amps	93			60			41		
Compressor 3 (Non-Inverter)	Rated Load Amps	13.1			6.6			4.8		
	Locked Rotor Amps	93			60			41		
Outdoor Fan Motors (3)	Full Load Amps (3 Non-ECM)	2.4			1.3			1		
	Total	7.2			3.9			3		
Power Exhaust (2) 0.33 HP	Full Load Amps	2.4			1.3			1		
	Total	4.8			2.6			2		
Service Outlet 115V GFI (amps)		15			15			20		
Indoor Blower Motor	HP	3	5	7.5	3	5	7.5	3	5	7.5
	Full Load Amps	10.6	16.7	24.2	4.8	7.6	11	3.9	6.1	9
<sup>2</sup> Maximum Overcurrent Protection (MOCP)	Unit Only	70	80	100	35	40	45	25	30	35
	With (2) 0.33 HP Power Exhaust	70	80	100	35	40	50	25	30	35
<sup>3</sup> Minimum Circuit Ampacity (MCA)	Unit Only	61	68	77	31	34	38	23	26	29
	With (2) 0.33 HP Power Exhaust	66	73	82	33	36	41	25	28	31

**ELECTRIC HEAT DATA**

Electric Heat Voltage			208V	240V	208V	240V	208V	240V	480V	480V	480V	600V	600V	600V
<sup>2</sup> Maximum Overcurrent Protection (MOCP)	Unit+ Electric Heat	15 kW	70	70	80	80	100	100	35	40	45	25	30	35
		30 kW	100	110	100	125	110	125	60	60	60	45	45	50
		45 kW	150	150	150	175	150	175	80	80	90	60	70	70
		60 kW	150	175	150	175	175	175	80	90	90	70	70	70
<sup>3</sup> Minimum Circuit Ampacity (MCA)	Unit+ Electric Heat	15 kW	61	61	68	68	77	77	31	34	38	23	26	30
		30 kW	92	104	100	112	109	121	52	55	59	41	44	48
		45 kW	131	149	139	157	148	166	74	78	82	60	62	66
		60 kW	139	158	146	166	156	175	79	82	86	63	66	69
<sup>2</sup> Maximum Overcurrent Protection (MOCP)	Unit+ Electric Heat and (2) 0.33 HP Power Exhaust	15 kW	70	70	80	80	100	100	35	40	50	30	30	35
		30 kW	100	110	110	125	125	150	60	60	70	45	50	50
		45 kW	150	175	150	175	175	175	80	90	90	70	70	70
		60 kW	150	175	175	175	175	200	90	90	90	70	70	80
<sup>3</sup> Minimum Circuit Ampacity (MCA)	Unit+ Electric Heat and (2) 0.33 HP Power Exhaust	15 kW	66	66	73	73	82	82	33	36	41	26	29	32
		30 kW	98	110	106	118	115	127	55	58	63	44	47	50
		45 kW	137	155	145	163	154	172	77	81	85	62	65	68
		60 kW	145	164	152	172	162	181	82	85	90	66	68	72

NOTE - All units have a minimum Short Circuit Current Rating (SCCR) of 5000 amps.

<sup>1</sup> Extremes of operating range are plus and minus 10% of line voltage.

<sup>2</sup> HACR type breaker or fuse.

<sup>3</sup> Refer to National or Canadian Electrical Code manual to determine wire, fuse and disconnect size requirements.

**ELECTRICAL/ELECTRIC HEAT DATA**

**17.5 TON**

Model		LCX210S5								
<sup>1</sup> Voltage - 60Hz		208/230V - 3 Ph			460V - 3 Ph			575V - 3 Ph		
Compressor 1 (Non-Inverter)	Rated Load Amps	21.2			9.1			7.7		
	Locked Rotor Amps	156.5			74.8			47.8		
Compressor 2 (Non-Inverter)	Rated Load Amps	21.2			9.1			7.7		
	Locked Rotor Amps	156.5			74.8			47.8		
Compressor 3 (Non-Inverter)	Rated Load Amps	21.2			9.1			7.7		
	Locked Rotor Amps	156.5			74.8			47.8		
Outdoor Fan Motors (3)	Full Load Amps (3 Non-ECM)	2.4			1.3			1		
	Total	7.2			3.9			3		
Power Exhaust (2) 0.33 HP	Full Load Amps	2.4			1.3			1		
	Total	4.8			2.6			2		
Service Outlet 115V GFI (amps)		15			15			20		
Indoor Blower Motor	HP	3	5	7.5	3	5	7.5	3	5	7.5
	Full Load Amps	10.6	16.7	24.2	4.8	7.6	11	3.9	6.1	9
<sup>2</sup> Maximum Overcurrent Protection (MOCP)	Unit Only	100	110	125	45	50	50	35	40	45
	With (2) 0.33 HP Power Exhaust	110	110	125	45	50	50	40	40	45
<sup>3</sup> Minimum Circuit Ampacity	Unit Only	87	93	102	39	42	45	32	35	38
	With (2) 0.33 HP Power Exhaust	92	98	106	41	44	48	34	37	40

**ELECTRIC HEAT DATA**

Electric Heat Voltage			208V	240V	208V	240V	208V	240V	480V	480V	480V	600V	600V	600V
<sup>2</sup> Maximum Overcurrent Protection (MOCP)	Unit+ Electric Heat	15 kW	100	100	110	110	125	125	45	50	50	35	40	45
		30 kW	100	110	110	125	125	125	60	60	60	45	45	50
		45 kW	150	150	150	175	150	175	80	80	90	60	70	70
		60 kW	150	175	150	175	175	175	80	90	90	70	70	70
		90 kW	225	250	225	250	225	250	125	125	125	100	100	100
<sup>3</sup> Minimum Circuit Ampacity (MCA)	Unit+ Electric Heat	15 kW	87	87	93	93	102	102	39	42	45	32	35	38
		30 kW	92	104	100	112	109	121	52	55	59	41	44	48
		45 kW	131	149	139	157	148	166	74	78	82	60	62	66
		60 kW	139	158	146	166	156	175	79	82	86	63	66	69
		90 kW	201	230	209	238	218	247	115	118	123	92	95	98
<sup>2</sup> Maximum Overcurrent Protection (MOCP) and (2) 0.33 HP Power Exhaust	Unit+ Electric Heat	15 kW	110	110	110	110	125	125	45	50	50	40	40	45
		30 kW	110	110	110	125	125	150	60	60	70	45	50	50
		45 kW	150	175	150	175	175	175	80	90	90	70	70	70
		60 kW	150	175	175	175	175	200	90	90	90	70	70	80
		90 kW	225	250	225	250	225	300	125	125	150	100	100	110
<sup>3</sup> Minimum Circuit Ampacity (MCA) and (2) 0.33 HP Power Exhaust	Unit+ Electric Heat	15 kW	92	92	98	98	106	106	41	44	48	34	37	40
		30 kW	98	110	106	118	115	127	55	58	63	44	47	50
		45 kW	137	155	145	163	154	172	77	81	85	62	65	68
		60 kW	145	164	152	172	162	181	82	85	90	66	68	72
		90 kW	207	236	215	244	224	253	118	122	126	94	97	101

NOTE - All units have a minimum Short Circuit Current Rating (SCCR) of 5000 amps.

<sup>1</sup> Extremes of operating range are plus and minus 10% of line voltage.

<sup>2</sup> HACR type breaker or fuse.

<sup>3</sup> Refer to National or Canadian Electrical Code manual to determine wire, fuse and disconnect size requirements.

**ELECTRICAL/ELECTRIC HEAT DATA**

**20 TON**

Model		LCX240S5								
<sup>1</sup> Voltage - 60Hz		208/230V - 3 Ph			460V - 3 Ph			575V - 3 Ph		
Compressor 1 (Non-Inverter)	Rated Load Amps	22.4			9.1			7.2		
	Locked Rotor Amps	166.2			74.6			54		
Compressor 2 (Non-Inverter)	Rated Load Amps	22.4			9.1			7.2		
	Locked Rotor Amps	166.2			74.6			54		
Compressor 3 (Non-Inverter)	Rated Load Amps	24.4			11.9			9.4		
	Locked Rotor Amps	210			103			78		
Outdoor Fan Motors (4)	Full Load Amps (4 Non-ECM)	2.4			1.3			1		
	Total	9.6			5.2			4		
Power Exhaust (2) 0.33 HP	Full Load Amps	2.4			1.3			1		
	Total	4.8			2.6			2		
Service Outlet 115V GFI (amps)		15			15			20		
Indoor Blower Motor	HP	5	7.5	10	5	7.5	10	5	7.5	10
	Full Load Amps	16.7	24.2	30.8	7.6	11	14	6.1	9	11
<sup>2</sup> Maximum Overcurrent Protection (MOCP)	Unit Only	125	125	125	50	60	60	45	45	50
	With (2) 0.33 HP Power Exhaust	125	125	150	60	60	60	45	50	50
<sup>3</sup> Minimum Circuit Ampacity (MCA)	Unit Only	102	110	118	46	50	53	37	40	42
	With (2) 0.33 HP Power Exhaust	107	114	123	49	52	56	39	42	44

**ELECTRIC HEAT DATA**

Electric Heat Voltage			208V	240V	208V	240V	208V	240V	480V	480V	480V	600V	600V	600V
<sup>2</sup> Maximum Overcurrent Protection (MOCP)	Unit+ Electric Heat	15 kW	125	125	125	125	125	125	50	60	60	45	45	50
		30 kW	125	125	125	125	125	150	60	60	70	45	50	50
		45 kW	150	175	150	175	175	175	80	90	90	70	70	70
		60 kW	150	175	175	175	175	200	90	90	90	70	70	80
		90 kW	225	250	225	250	250	300	125	125	150	100	100	110
<sup>3</sup> Minimum Circuit Ampacity (MCA)	Unit+ Electric Heat	15 kW	102	102	110	110	118	118	46	50	53	37	40	42
		30 kW	102	112	110	121	118	129	55	59	63	44	48	50
		45 kW	139	157	148	166	156	174	78	82	86	62	66	68
		60 kW	146	166	156	175	164	183	82	86	90	66	69	72
		90 kW	209	238	218	247	227	256	118	123	126	95	98	101
<sup>2</sup> Maximum Overcurrent Protection (MOCP)	Unit+ Electric Heat and (2) 0.33 HP Power Exhaust	15 kW	125	125	125	125	150	150	60	60	60	45	50	50
		30 kW	125	125	125	150	150	150	60	70	70	50	50	60
		45 kW	150	175	175	175	175	200	90	90	90	70	70	80
		60 kW	175	175	175	200	175	200	90	90	100	70	80	80
		90 kW	225	250	225	4 300	250	300	125	150	150	100	110	110
<sup>3</sup> Minimum Circuit Ampacity (MCA)	Unit+ Electric Heat and (2) 0.33 HP Power Exhaust	15 kW	107	107	114	114	123	123	49	52	56	39	42	44
		30 kW	107	118	115	127	123	135	58	63	66	47	50	53
		45 kW	145	163	154	172	162	180	81	85	89	65	68	71
		60 kW	152	172	162	181	170	189	85	90	93	68	72	74
		90 kW	215	244	224	253	233	262	122	126	130	97	101	103

NOTE - All units have a minimum Short Circuit Current Rating (SCCR) of 5000 amps.

<sup>1</sup> Extremes of operating range are plus and minus 10% of line voltage.

<sup>2</sup> HACR type breaker or fuse.

<sup>3</sup> Refer to National or Canadian Electrical Code manual to determine wire, fuse and disconnect size requirements.

**ELECTRICAL/ELECTRIC HEAT DATA**

**25 TON**

Model		LCX300S5								
<sup>1</sup> Voltage - 60Hz		208/230V - 3 Ph			460V - 3 Ph			575V - 3 Ph		
Compressor 1 (Non-Inverter)	Rated Load Amps	21.2			9.1			7.7		
	Locked Rotor Amps	156.5			74.8			47.8		
Compressor 2 (Non-Inverter)	Rated Load Amps	21.2			9.1			7.7		
	Locked Rotor Amps	156.5			74.8			47.8		
Compressor 3 (Non-Inverter)	Rated Load Amps	22.4			9.1			7.2		
	Locked Rotor Amps	166.2			74.6			54		
Compressor 4 (Non-Inverter)	Rated Load Amps	22.4			9.1			7.2		
	Locked Rotor Amps	166.2			74.6			54		
Outdoor Fan Motors (6)	Full Load Amps (6 Non-ECM)	2.4			1.3			1		
	Total	14.4			7.8			6		
Power Exhaust (2) 0.33 HP	Full Load Amps	2.4			1.3			1		
	Total	4.8			2.6			2		
Service Outlet 115V GFI (amps)		15			15			20		
Indoor Blower Motor	HP	5	7.5	10	5	7.5	10	5	7.5	10
	Full Load Amps	16.7	24.2	30.8	7.6	11	14	6.1	9	11
<sup>2</sup> Maximum Overcurrent Protection (MOCP)	Unit Only	125	150	150	60	60	70	50	50	60
	With (2) 0.33 HP Power Exhaust	150	150	175	60	70	70	50	50	60
<sup>3</sup> Minimum Circuit Ampacity (MCA)	Unit Only	124	132	141	55	58	62	44	48	50
	With (2) 0.33 HP Power Exhaust	129	137	145	57	61	65	46	50	52

**ELECTRIC HEAT DATA**

Electric Heat Voltage			208V	240V	208V	240V	208V	240V	480V	480V	480V	600V	600V	600V
<sup>2</sup> Maximum Overcurrent Protection (MOCP)	Unit+ Electric Heat	15 kW	125	125	150	150	150	150	60	60	70	50	50	60
		30 kW	125	125	150	150	150	150	60	60	70	50	50	60
		45 kW	150	175	150	175	175	175	80	90	90	70	70	70
		60 kW	150	175	175	175	175	200	90	90	90	70	70	80
		90 kW	225	250	225	250	250	300	125	125	150	100	100	110
<sup>3</sup> Minimum Circuit Ampacity (MCA)	Unit+ Electric Heat	15 kW	124	124	132	132	141	141	55	58	62	44	48	50
		30 kW	124	124	132	132	141	141	55	59	63	44	48	50
		45 kW	139	157	148	166	156	174	78	82	86	62	66	68
		60 kW	146	166	156	175	164	183	82	86	90	66	69	72
		90 kW	209	238	218	247	227	256	118	123	126	95	98	101
<sup>2</sup> Maximum Overcurrent Protection (MOCP)	Unit+ Electric Heat and (2) 0.33 HP Power Exhaust	15 kW	150	150	150	150	175	175	60	70	70	50	50	60
		30 kW	150	150	150	150	175	175	60	70	70	50	50	60
		45 kW	150	175	175	175	175	200	90	90	90	70	70	80
		60 kW	175	175	175	200	175	200	90	90	100	70	80	80
		90 kW	225	250	225	300	250	300	125	150	150	100	110	110
<sup>3</sup> Minimum Circuit Ampacity (MCA)	Unit+ Electric Heat and (2) 0.33 HP Power Exhaust	15 kW	129	129	137	137	145	145	57	61	65	46	50	52
		30 kW	129	129	137	137	145	145	58	63	66	47	50	53
		45 kW	145	163	154	172	162	180	81	85	89	65	68	71
		60 kW	152	172	162	181	170	189	85	90	93	68	72	74
		90 kW	215	244	224	253	233	262	122	126	130	97	101	103

NOTE - All units have a minimum Short Circuit Current Rating (SCCR) of 5000 amps.

<sup>1</sup> Extremes of operating range are plus and minus 10% of line voltage.

<sup>2</sup> HACR type breaker or fuse.

<sup>3</sup> Refer to National or Canadian Electrical Code manual to determine wire, fuse and disconnect size requirements.

## ELECTRICAL ACCESSORIES - DISCONNECTS

### 15 TON | LCX180S5

Motor HP	3		5		7.5		3	5	7.5	3	5	7.5
	208V	240V	208V	240V	208V	240V	480V	480V	480V	600V	600V	600V
Unit Only	54W85	54W85	54W85	54W85	54W86	54W86	54W85	54W85	54W85	54W85	54W85	54W85
+ Power Exhaust	54W85	54W85	54W85	54W85	54W86	54W86	54W85	54W85	54W85	54W85	54W85	54W85
+ Electric Heat 15 kW	54W85	54W85	54W85	54W85	54W86	54W86	54W85	54W85	54W85	54W85	54W85	54W85
+ Electric Heat 30 kW	54W86	54W86	54W86	54W86	54W86	54W86	54W85	54W85	54W85	54W85	54W85	54W85
+ Electric Heat 45 kW	54W87	54W86	54W87	54W86	54W87	54W87	54W85	54W85	54W85	54W85	54W85	54W85
+ Electric Heat 60 kW	54W87	54W87	54W87	54W87	54W87	54W87	54W86	54W86	54W86	54W85	54W85	54W85
+ Power Exhaust + Elec. Heat 15 kW	54W85	54W85	54W85	54W85	54W86	54W86	54W85	54W85	54W85	54W85	54W85	54W85
+ Power Exhaust + Elec. Heat 30 kW	54W86	54W86	54W86	54W86	54W86	54W86	54W85	54W85	54W85	54W85	54W85	54W85
+ Power Exhaust + Elec. Heat 45 kW	54W87	54W86	54W87	54W86	54W87	54W87	54W85	54W85	54W85	54W85	54W85	54W85
+ Power Exhaust + Elec. Heat 60 kW	54W87	54W87	54W87	54W87	54W87	54W87	54W86	54W86	54W86	54W85	54W85	54W85

### 17.5 TON | LCX210S5

Motor HP	3		5		7.5		3	5	7.5	3	5	7.5
	208V	240V	208V	240V	208V	240V	480V	480V	480V	600V	600V	600V
Unit Only	54W86	54W86	54W86	54W86	54W86	54W86	54W85	54W85	54W85	54W85	54W85	54W85
+ Power Exhaust	54W86	54W86	54W86	54W86	54W86	54W86	54W85	54W85	54W85	54W85	54W85	54W85
+ Electric Heat 15 kW	54W86	54W86	54W86	54W86	54W86	54W86	54W85	54W85	54W85	54W85	54W85	54W85
+ Electric Heat 30 kW	54W86	54W86	54W86	54W86	54W86	54W86	54W85	54W85	54W85	54W85	54W85	54W85
+ Electric Heat 45 kW	54W87	54W86	54W87	54W86	54W87	54W87	54W85	54W85	54W85	54W85	54W85	54W85
+ Electric Heat 60 kW	54W87	54W87	54W87	54W87	54W87	54W87	54W86	54W86	54W86	54W85	54W85	54W85
+ Electric Heat 90 kW	<sup>1</sup> NA	<sup>1</sup> NA	<sup>1</sup> NA	<sup>1</sup> NA	<sup>1</sup> NA	<sup>1</sup> NA	54W86	54W86	54W86	54W86	54W86	54W86
+ Power Exhaust + Elec. Heat 15 kW	54W86	54W86	54W86	54W86	54W86	54W86	54W85	54W85	54W85	54W85	54W85	54W85
+ Power Exhaust + Elec. Heat 30 kW	54W86	54W86	54W86	54W86	54W86	54W86	54W85	54W85	54W85	54W85	54W85	54W85
+ Power Exhaust + Elec. Heat 45 kW	54W87	54W86	54W87	54W86	54W87	54W87	54W85	54W85	54W85	54W85	54W85	54W85
+ Power Exhaust + Elec. Heat 60 kW	54W87	54W87	54W87	54W87	54W87	54W87	54W86	54W86	54W86	54W85	54W85	54W85
+ Power Exhaust + Elec. Heat 90 kW	<sup>1</sup> NA	<sup>1</sup> NA	<sup>1</sup> NA	<sup>1</sup> NA	<sup>1</sup> NA	<sup>1</sup> NA	54W86	54W86	54W86	54W86	54W86	54W86

Disconnects - 54W85 - 80A  
 54W86 - 150A  
 54W87 - 250A

<sup>1</sup> Disconnect must be field furnished.

## ELECTRICAL ACCESSORIES - DISCONNECTS

### 20 TON | LCX240S5

Motor HP Electric Heat Voltage	5		7.5		10		5	7.5	10	5	7.5	10
	208V	240V	208V	240V	208V	240V	480V	480V	480V	600V	600V	600V
Unit Only	54W86	54W86	54W86	54W86	54W86	54W86	54W85	54W85	54W85	54W85	54W85	54W85
+ Power Exhaust	54W86	54W86	54W86	54W86	54W86	54W86	54W85	54W85	54W85	54W85	54W85	54W85
+ Electric Heat 15 kW	54W86	54W86	54W86	54W86	54W86	54W86	54W85	54W85	54W85	54W85	54W85	54W85
+ Electric Heat 30 kW	54W86	54W86	54W86	54W86	54W86	54W86	54W85	54W85	54W85	54W85	54W85	54W85
+ Electric Heat 45 kW	54W87	54W86	54W87	54W87	54W87	54W87	54W85	54W85	54W85	54W85	54W85	54W85
+ Electric Heat 60 kW	54W87	54W87	54W87	54W87	54W87	54W87	54W86	54W86	54W86	54W85	54W85	54W85
+ Electric Heat 90 kW	<sup>1</sup> NA	<sup>1</sup> NA	<sup>1</sup> NA	<sup>1</sup> NA	<sup>1</sup> NA	<sup>1</sup> NA	54W86	54W86	54W86	54W86	54W86	54W86
+ Power Exhaust + Elec. Heat 15 kW	54W86	54W86	54W86	54W86	54W86	54W86	54W85	54W85	54W85	54W85	54W85	54W85
+ Power Exhaust + Elec. Heat 30 kW	54W86	54W86	54W86	54W86	54W86	54W86	54W85	54W85	54W85	54W85	54W85	54W85
+ Power Exhaust + Elec. Heat 45 kW	54W87	54W86	54W87	54W87	54W87	54W87	54W85	54W85	54W86	54W85	54W85	54W85
+ Power Exhaust + Elec. Heat 60 kW	54W87	54W87	54W87	54W87	54W87	54W87	54W86	54W86	54W86	54W85	54W85	54W86
+ Power Exhaust + Elec. Heat 90 kW	<sup>1</sup> NA	<sup>1</sup> NA	<sup>1</sup> NA	<sup>1</sup> NA	<sup>1</sup> NA	<sup>1</sup> NA	54W86	54W86	54W86	54W86	54W86	54W86

### 25 TON | LCX300S5

Motor HP Electric Heat Voltage	5		7.5		10		5	7.5	10	5	7.5	10
	208V	240V	208V	240V	208V	240V	480V	480V	480V	600V	600V	600V
Unit Only	54W86	54W86	54W86	54W86	54W87	54W87	54W85	54W85	54W85	54W85	54W85	54W85
+ Power Exhaust	54W86	54W86	54W87	54W87	54W87	54W87	54W85	54W85	54W85	54W85	54W85	54W85
+ Electric Heat 15 kW	54W86	54W86	54W86	54W86	54W87	54W87	54W85	54W85	54W85	54W85	54W85	54W85
+ Electric Heat 30 kW	54W86	54W86	54W86	54W86	54W87	54W87	54W85	54W85	54W85	54W85	54W85	54W85
+ Electric Heat 45 kW	54W87	54W86	54W87	54W87	54W87	54W87	54W85	54W85	54W85	54W85	54W85	54W85
+ Electric Heat 60 kW	54W87	54W87	54W87	54W87	54W87	54W87	54W86	54W86	54W86	54W85	54W85	54W85
+ Electric Heat 90 kW	<sup>1</sup> NA	<sup>1</sup> NA	<sup>1</sup> NA	<sup>1</sup> NA	<sup>1</sup> NA	<sup>1</sup> NA	54W86	54W86	54W86	54W86	54W86	54W86
+ Power Exhaust + Elec. Heat 15 kW	54W86	54W86	54W87	54W87	54W87	54W87	54W85	54W85	54W85	54W85	54W85	54W85
+ Power Exhaust + Elec. Heat 30 kW	54W86	54W86	54W87	54W87	54W87	54W87	54W85	54W85	54W85	54W85	54W85	54W85
+ Power Exhaust + Elec. Heat 45 kW	54W87	54W86	54W87	54W87	54W87	54W87	54W85	54W85	54W86	54W85	54W85	54W85
+ Power Exhaust + Elec. Heat 60 kW	54W87	54W87	54W87	54W87	54W87	54W87	54W86	54W86	54W86	54W85	54W85	54W86
+ Power Exhaust + Elec. Heat 90 kW	<sup>1</sup> NA	<sup>1</sup> NA	<sup>1</sup> NA	<sup>1</sup> NA	<sup>1</sup> NA	<sup>1</sup> NA	54W86	54W86	54W86	54W86	54W86	54W86

Disconnects - 54W85 - 80A  
 54W86 - 150A  
 54W87 - 250A

<sup>1</sup> Disconnect must be field furnished.

#### FIELD WIRING NOTES

- For use with copper wiring only
- Field wiring not furnished
- All wiring must conform to NEC or CEC and local electrical codes
- For specific wiring information, please refer to the installation instructions

## ELECTRIC HEAT CAPACITIES

Volts Input	15 kW			30 kW			45 kW			60 kW			90 kW		
	kW Input	Btuh Output	Stages	kW Input	Btuh Output	Stages	kW Input	Btuh Output	Stages	kW Input	Btuh Output	Stages	kW Input	Btuh Output	Stages
208	11.3	38,600	1	22.5	76,800	1	33.8	115,300	2	45.0	153,600	2	67.6	230,700	2
220	12.6	43,000	1	25.2	86,000	1	37.8	129,000	2	50.4	172,000	2	75.6	258,000	2
230	13.8	47,100	1	27.5	93,900	1	41.3	141,000	2	55.1	188,000	2	82.7	282,200	2
240	15.0	51,200	1	30.0	102,400	1	45.0	153,600	2	60.0	204,800	2	90.0	307,100	2
440	12.6	43,000	1	25.2	86,000	1	37.8	129,000	2	50.4	172,000	2	75.6	258,000	2
460	13.8	47,100	1	27.5	93,900	1	41.3	141,000	2	55.1	188,000	2	82.7	282,200	2
480	15.0	51,200	1	30.0	102,400	1	45.0	153,600	2	60.0	204,800	2	90.0	307,100	2
550	12.6	43,000	1	25.2	86,000	1	37.8	129,000	2	50.4	172,000	2	75.6	258,000	2
575	13.8	47,100	1	27.5	93,900	1	41.3	141,000	2	55.1	188,000	2	82.7	282,200	2
600	15.0	51,200	1	30.0	102,400	1	45.0	153,600	2	60.0	204,800	2	90.0	307,100	2

## UNIT CLEARANCES

### Unit With Economizer

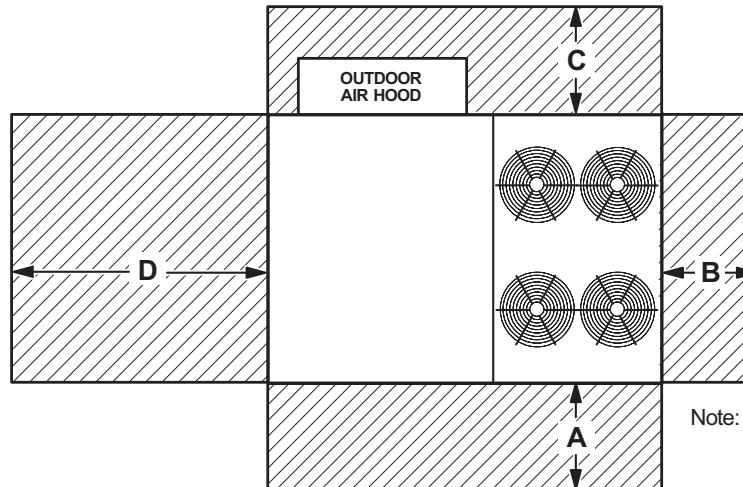

Note: Models with four outdoor fans shown.  
Dimension clearances are for all sizes.

<sup>1</sup> Unit Clearance	A		B		C		D		Top Clearance
	in.	mm	in.	mm	in.	mm	in.	mm	
<b>Service Clearance</b>	60	1524	36	914	36	914	66	1676	Unobstructed
<b>Minimum Operation Clearance</b>	45	1143	36	914	36	914	41	1041	

NOTE - Entire perimeter of unit base requires support when elevated above the mounting surface.

<sup>1</sup> Service Clearance - Required for removal of serviceable parts.

Minimum Operation Clearance - Required clearance for proper unit operation.

## OUTDOOR SOUND DATA

Size	Octave Band Sound Power Levels dBA, re 10 <sup>-12</sup> Watts - Center Frequency - Hz							<sup>1</sup> Sound Rating Number (SRN) (dBA)
	125	250	500	1000	2000	4000	8000	
180, 210	71	78	81	81	76	71	63	86
240	80	83	87	88	84	80	71	93
300	79	84	88	89	85	82	73	94

Note - The octave sound power data does not include tonal corrections.

<sup>1</sup> Sound Rating Number according to AHRI Standard 270-95 (includes pure tone penalty). Sound Rating Number is the overall A-Weighted Sound Power Level, (LWA), dBA (100 Hz to 10,000 Hz).

## WEIGHT DATA

Size	Net		Shipping	
	lbs.	kg	lbs.	kg
180S Base Unit	1724	782	1924	873
180S Max. Unit	2044	927	2244	1018
210S Base Unit	1884	855	2084	945
210S Max. Unit	2214	1004	2414	1095
240S Base Unit	2056	933	2256	1023
240S Max. Unit	2386	1082	2586	1173
300S Base Unit	2300	1043	2500	1134
300S Max. Unit	2590	1175	2790	1266

NOTE - Max. Unit is the unit with ALL INTERNAL OPTIONS Installed. (Economizer, Standard Static Power Exhaust Fans, Controls, etc.). Does not include accessories EXTERNAL to unit.

## FACTORY / FIELD INSTALLED OPTIONS AND ACCESSORIES - NET WEIGHTS

Description	lbs.	kg	
<b>ECONOMIZER / OUTDOOR AIR / EXHAUST</b>			
<b>Economizer</b>			
Economizer Dampers (with Outdoor Air Hood)	102	46	
Barometric Relief Dampers (downflow)	30	14	
Barometric Relief Dampers (horizontal)	20	9	
<b>Outdoor Air Dampers With Hood (Downflow)</b>			
Motorized	39	18	
Manual	22	10	
<b>Power Exhaust</b>	62	28	
<b>ELECTRIC HEAT</b>			
15 kW	59	27	
30 kW	59	27	
45 kW	76	34	
60 kW	76	34	
90 kW	84	38	
<b>COMBINATION COIL/HAIL GUARDS</b>			
180/210	30	13	
240/300	36	16	
<b>ROOF CURBS</b>			
<b>Hybrid Roof Curbs, Downflow</b>			
8 in. height	136	62	
14 in. height	169	77	
18 in. height	191	87	
24 in. height	224	102	
<b>Adjustable Pitch Curb, Downflow</b>			
14 in. height	224	102	
<b>Horizontal Roof Curbs, Standard</b>			
26 in. height	450	204	
37 in. height	540	245	
30 in. height	495	225	
41 in. height	575	261	
<b>CEILING DIFFUSERS</b>			
Step-Down	RTD11-185S	168	76
	RTD11-275S	238	108
Flush	FD11-185S	168	76
	FD11-275S	238	108
Transitions	C1DIFF33C-1	80	36
	C1DIFF34C-1	75	34
<b>HUMIDITROL® DEHUMIDIFICATION SYSTEM</b>			
Humiditrol Dehumidification Option	50	23	

**DIMENSIONS - UNIT**

**LCX180 | LCX210**

Model	CORNER WEIGHTS								CENTER OF GRAVITY			
	AA		BB		CC		DD		EE		FF	
	lbs.	kg	lbs.	kg	lbs.	kg	lbs.	kg	in.	mm	in.	mm
LCX180S Base Unit	393	179	346	157	461	210	523	238	50-1/2	1282	39	993
LCX180S Max. Unit	507	231	414	188	505	229	618	281	48-3/8	1230	41	1043
LCX210S Base Uni	431	196	381	173	503	229	569	259	50-1/2	1284	39-1/4	998
LCX210S Max. Unit	555	252	469	213	545	248	645	293	49-3/8	1254	42.14	1071

Base Unit - The unit with NO INTERNAL OPTIONS.

Max. Unit - The unit with ALL INTERNAL OPTIONS Installed. (Economizer, Standard Static Power Exhaust Fans, Controls, etc.). Does not include accessories external to unit.

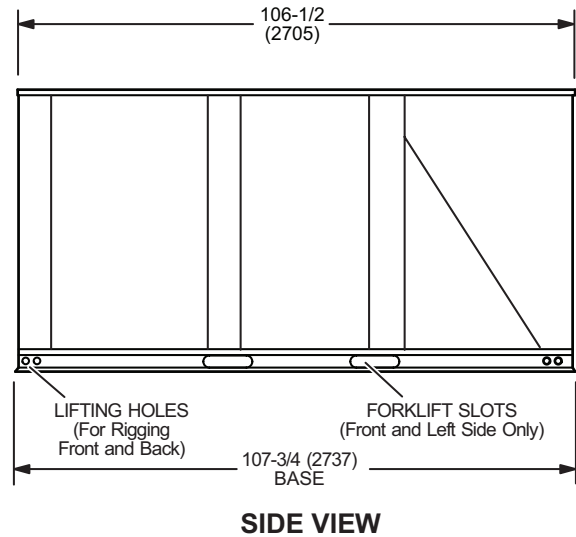
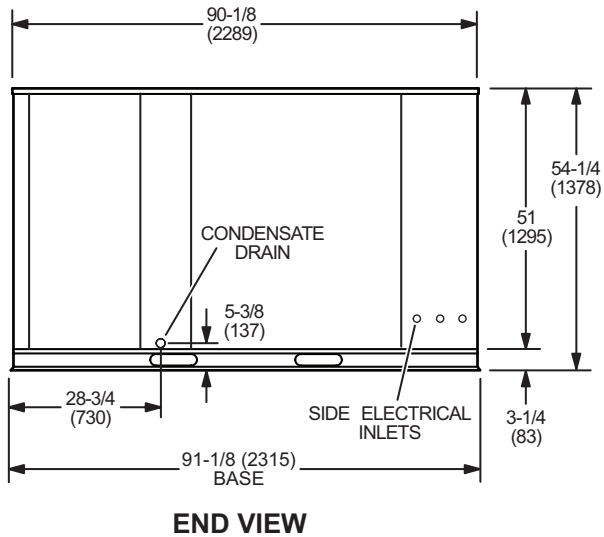
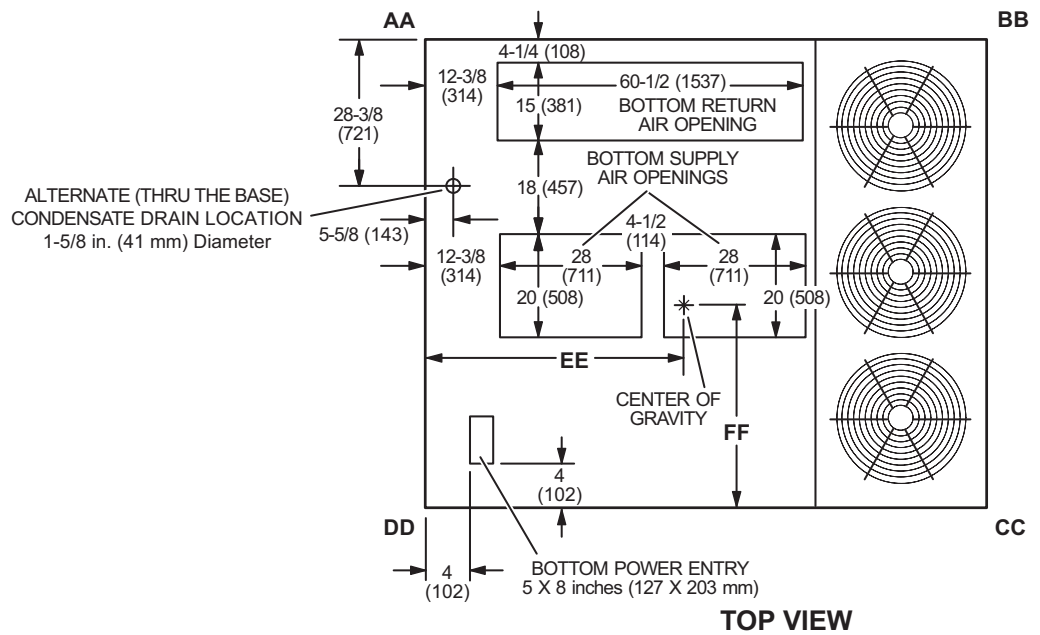

**DIMENSIONS - UNIT**

**LCX240**

CORNER WEIGHTS									CENTER OF GRAVITY			
Model	AA		BB		CC		DD		EE		FF	
	lbs.	kg	lbs.	kg	lbs.	kg	lbs.	kg	in.	mm	in.	mm
LCX240S Base Unit	459	209	423	192	563	256	611	278	51-3/4	1313	39-1/8	993
LCX240S Max. Unit	579	263	522	237	610	277	675	307	51-1/8	1298	42	1068

Base Unit - The unit with NO INTERNAL OPTIONS.

Max. Unit - The unit with ALL INTERNAL OPTIONS Installed. (Economizer, Standard Static Power Exhaust Fans, Controls, etc.). Does not include accessories external to unit.

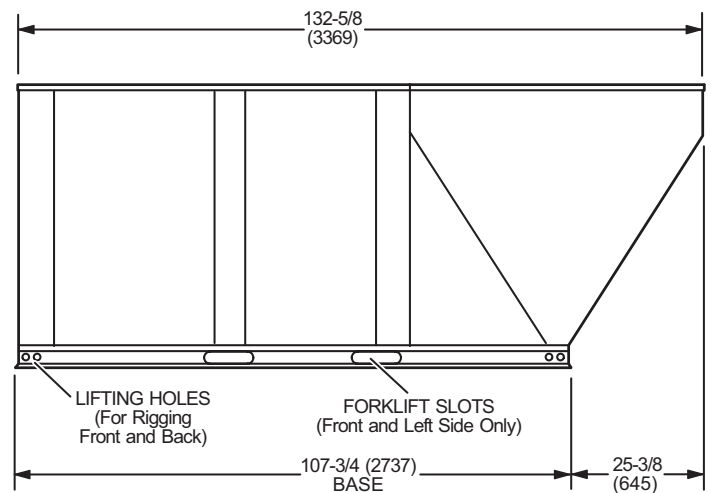
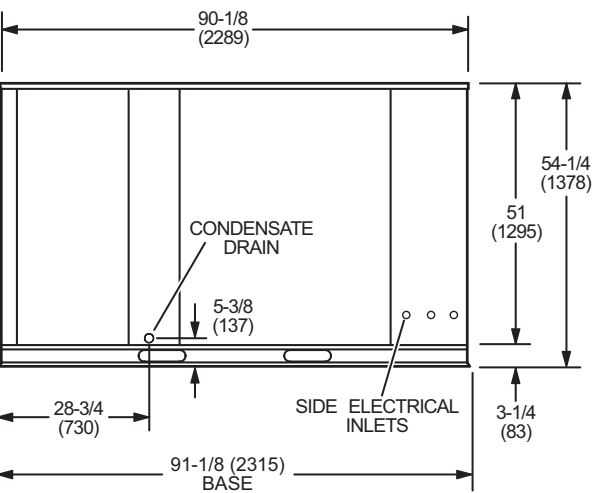
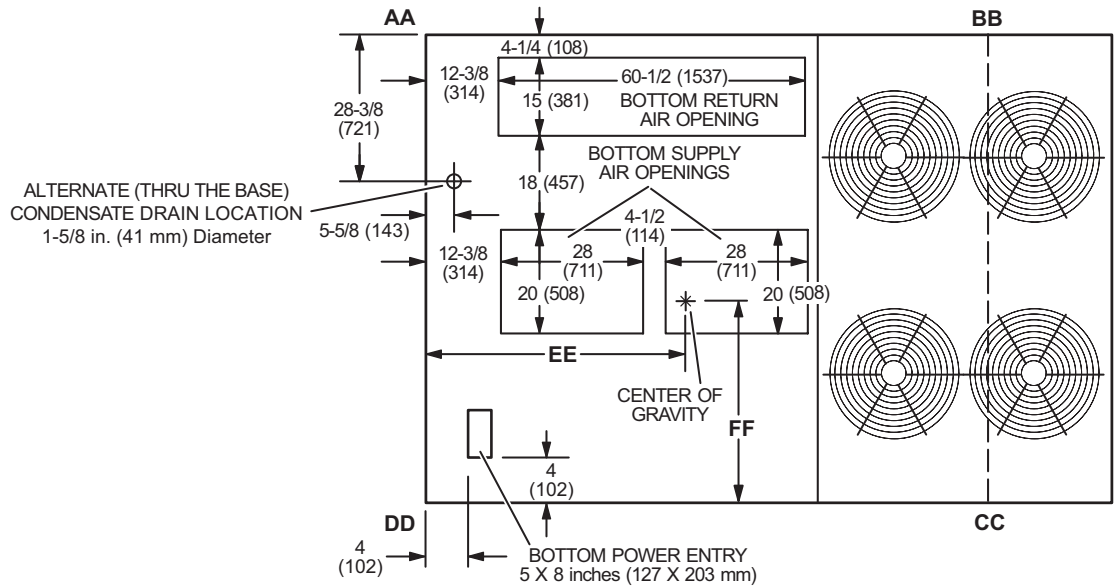

**DIMENSIONS - UNIT**

**LCX300**

**CORNER WEIGHTS**

**CENTER OF GRAVITY**

Model	AA		BB		CC		DD		EE		FF	
	lbs.	kg	lbs.	kg	lbs.	kg	lbs.	kg	in.	mm	in.	mm
LCX300S Base Unit	457	208	477	217	697	317	669	304	55	1397	37	940
LCX300S Max. Unit	553	251	556	253	742	337	739	336	54	1372	39	991

Base Unit - The unit with NO INTERNAL OPTIONS.

Max. Unit - The unit with ALL INTERNAL OPTIONS Installed. (Economizer, Standard Static Power Exhaust Fans, Controls, etc.). Does not include accessories external to unit.

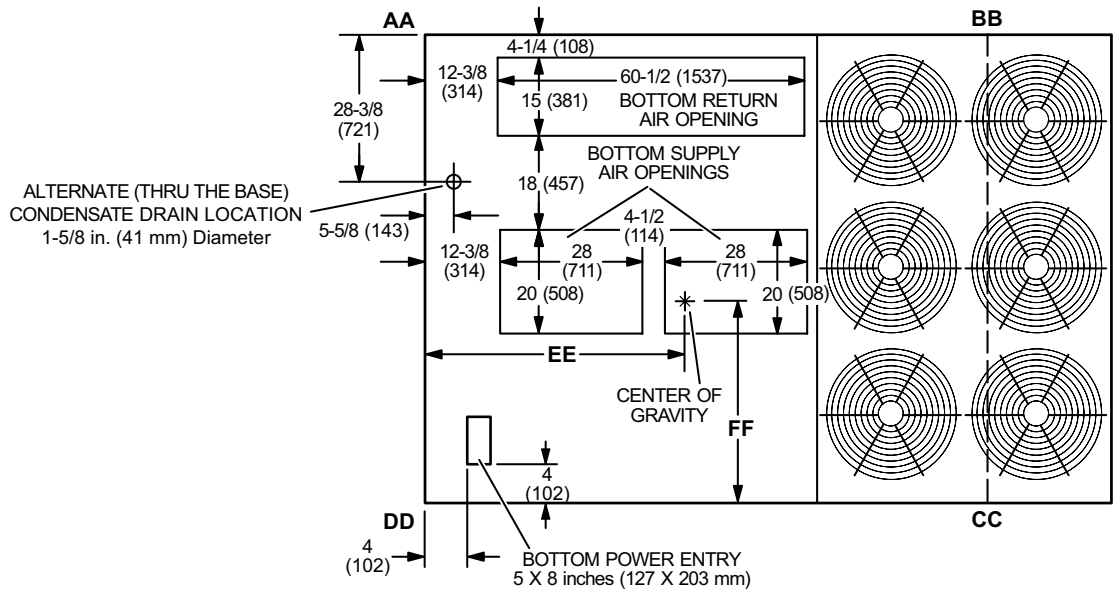

**TOP VIEW**

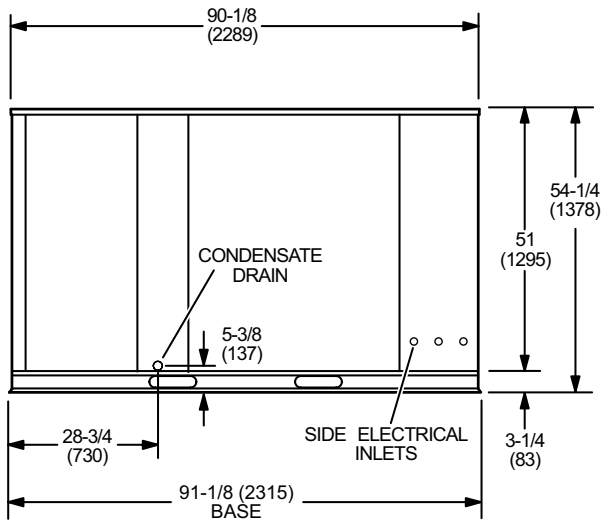

**END VIEW**

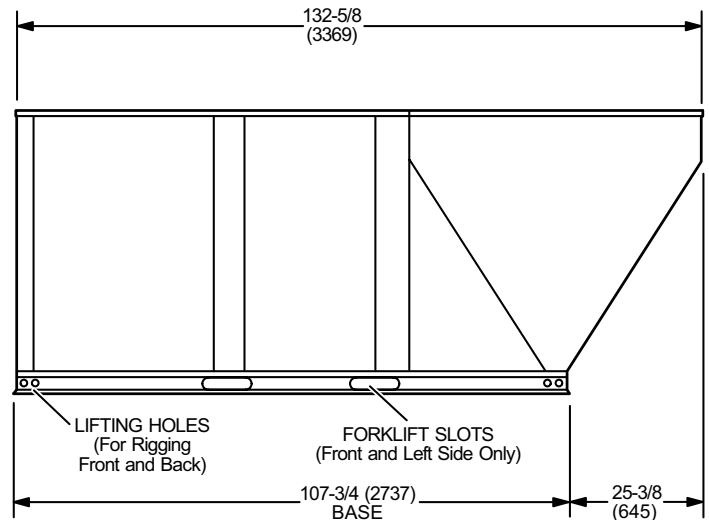

**SIDE VIEW**

**OUTDOOR AIR HOOD DETAIL**

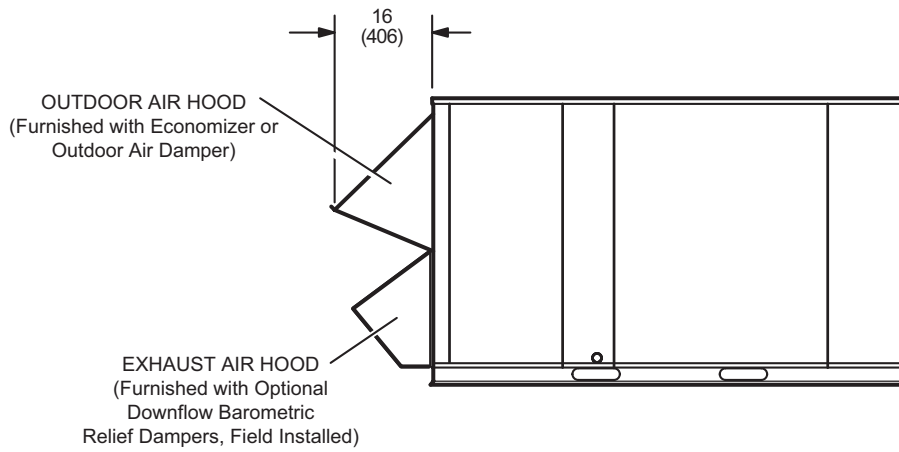

**OPTIONAL HORIZONTAL BAROMETRIC RELIEF DAMPERS WITH HOOD**

(Field installed in horizontal return air duct adjacent to unit)

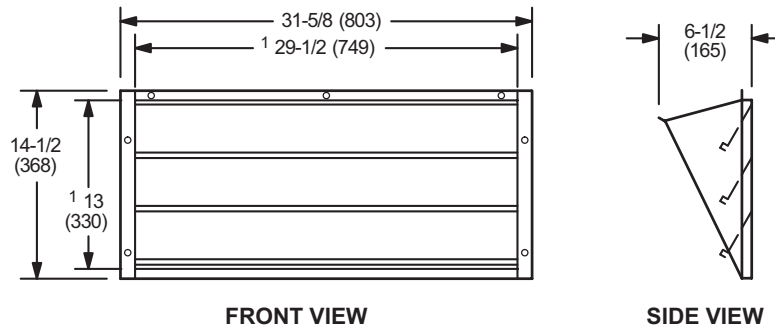

NOTE - Two furnished per order no.  
<sup>1</sup> NOTE - Opening size required in return air duct.



**ADJUSTABLE PITCH CURB - DOUBLE DUCT OPENING**

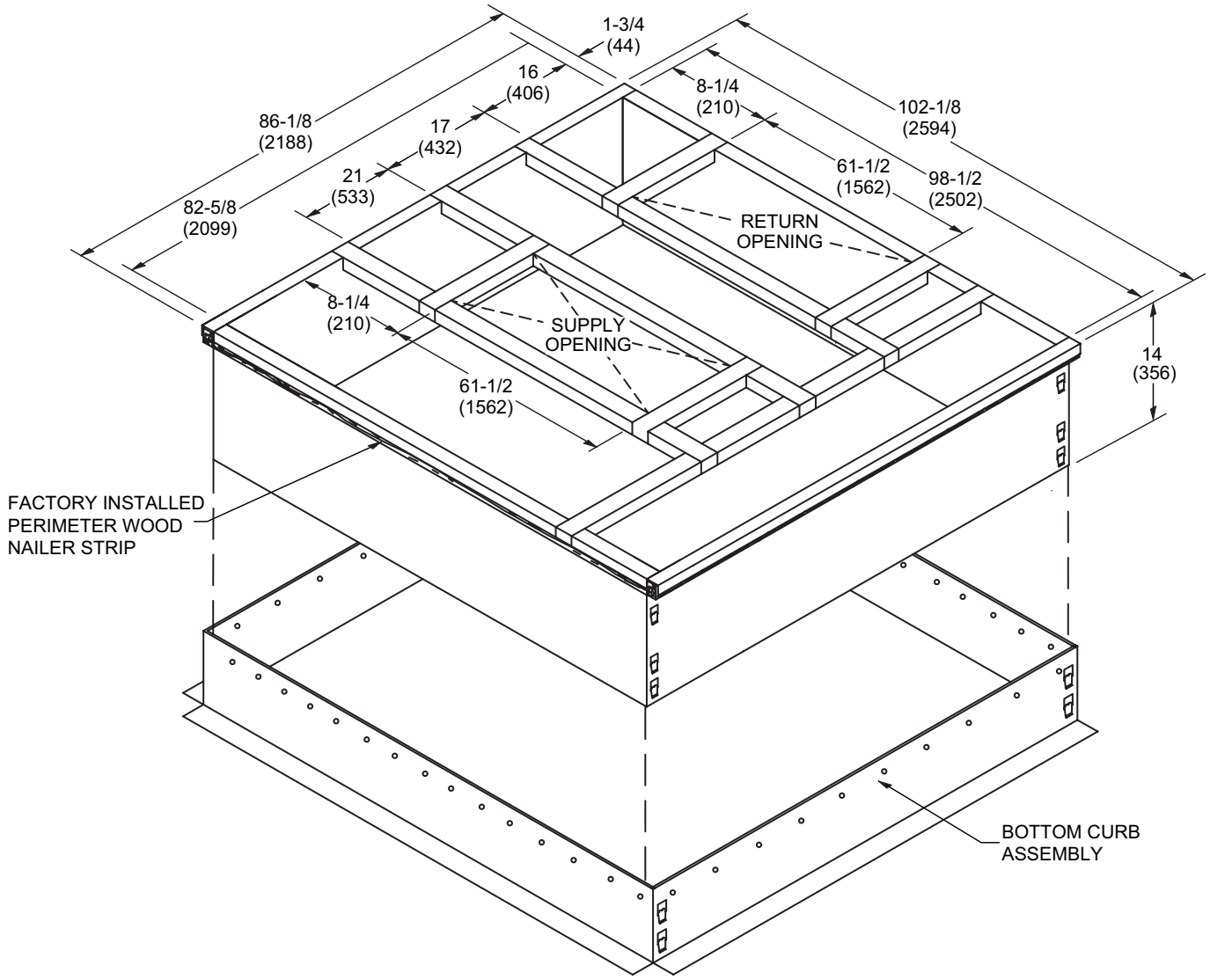

NOTE - Maximum slope pitch is 3/4 in. per 1 foot (19 mm per 305 mm) in any one direction.

**TYPICAL FLASHING DETAIL FOR ROOF CURB**

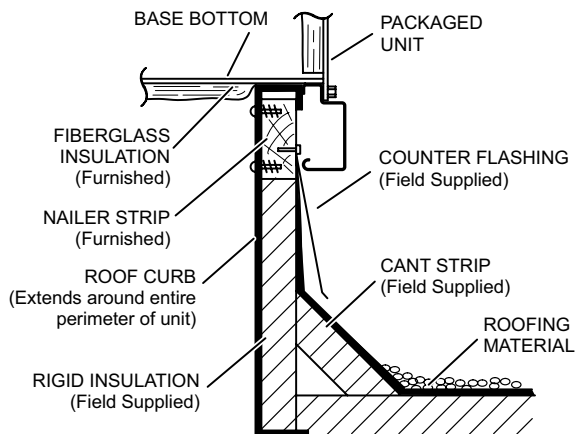

**DETAIL ROOF CURB**

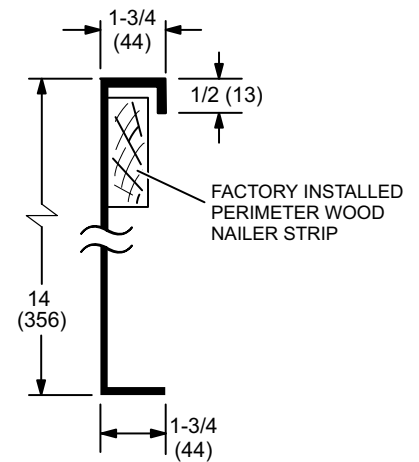

**ROOF CURBS WITH SUPPLY & RETURN AIR TRANSITIONS FOR CEILING DIFFUSERS**

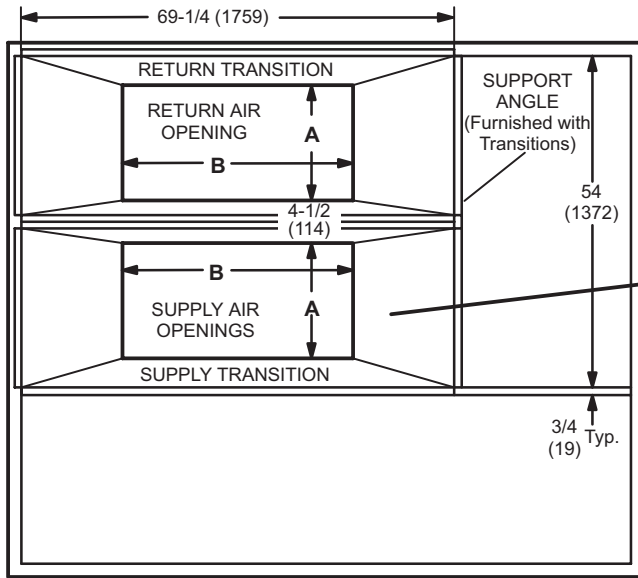

**TOP VIEW**

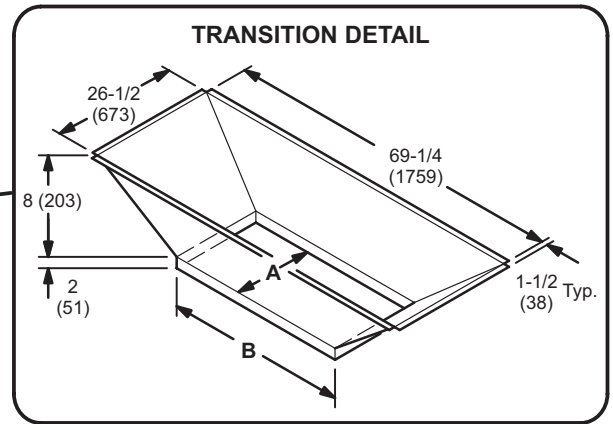

**TRANSITION OPENING SIZES**

Model Number	A		B	
	inch	mm	inch	mm
C1DIFF33C-1	18	457	36	914
C1DIFF34C-1	24	610	48	1219

**HORIZONTAL ROOF CURBS – Requires Optional Horizontal Return Air Panel Kit**

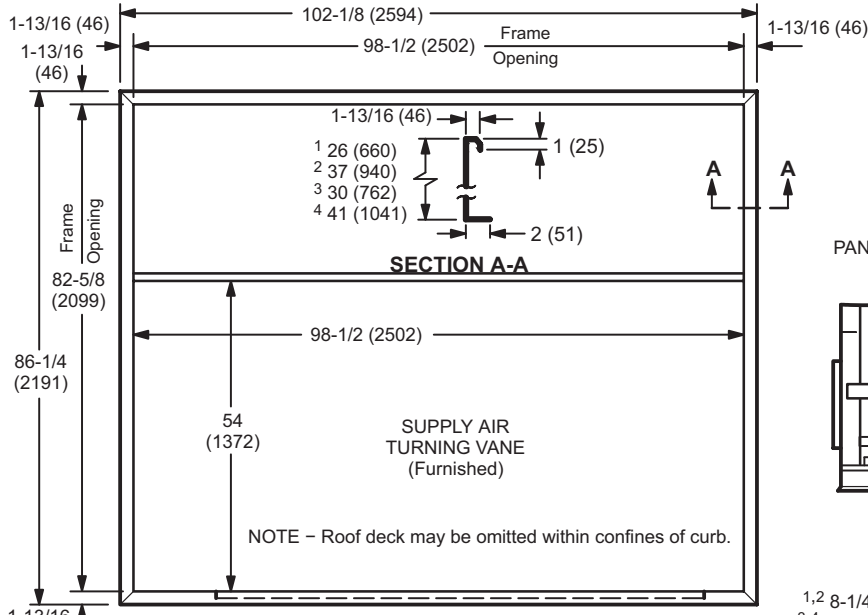

NOTE 26 in. (660 mm) and 30 in. (762 mm) height Curbs are designed for horizontal discharge when unit is mounted on a slab.  
37 in. (940 mm) and 41 in. (1041 mm) height Curbs are designed for horizontal discharge when unit is mounted on a rooftop.

PANEL TO COVER RETURN AIR OPENING IN BOTTOM OF UNIT (Furnished With Optional Horizontal Return Air Panel Kit)

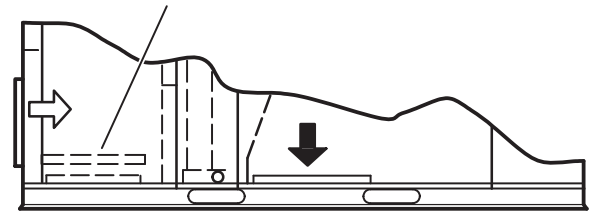

**SIDE VIEW (Packaged Unit)**

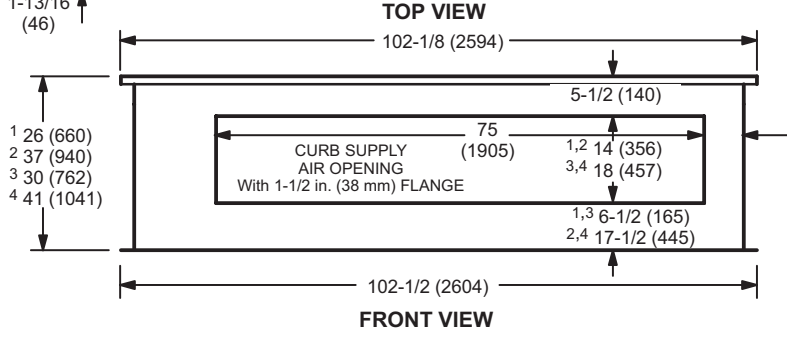

<sup>1,2</sup> 8-1/4 (210)  
<sup>3,4</sup> 13-1/4 (337)

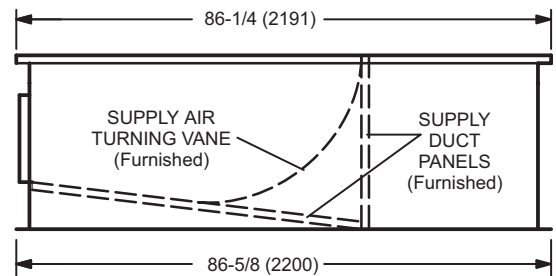

**SIDE VIEW**

<sup>1</sup> Slab Applications   <sup>2</sup> Rooftop Applications   <sup>3</sup> Slab Applications (used with 300)   <sup>4</sup> Rooftop Applications (used with 300)

**HORIZONTAL SUPPLY AND RETURN AIR OPENINGS WITH HORIZONTAL ROOF CURB**

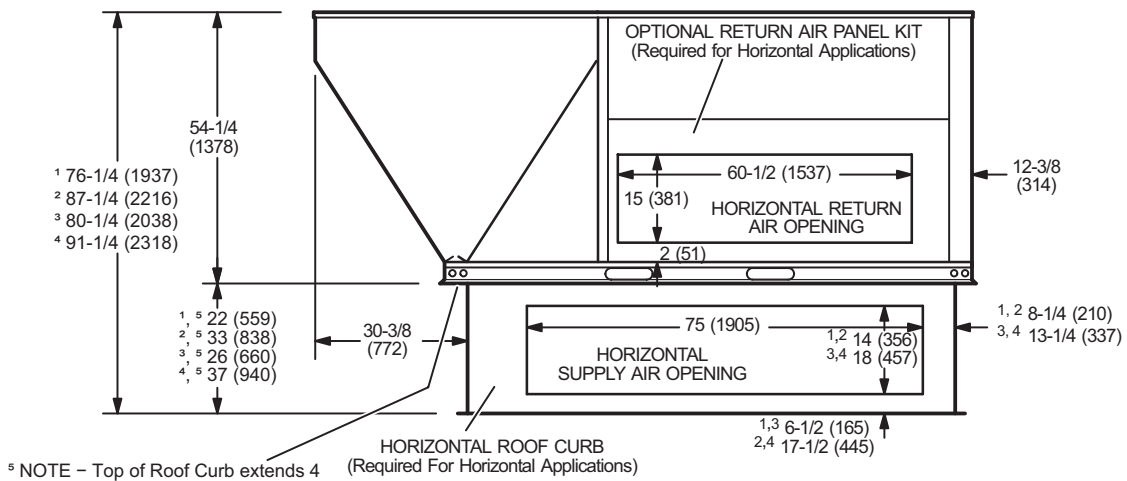

<sup>1</sup> Slab Applications  
<sup>2</sup> Rooftop Applications  
<sup>3</sup> Slab Applications (used with 300 Models Only)  
<sup>4</sup> Rooftop Applications (used with 300 Models Only)

## DIMENSIONS

## OPTIONAL ACCESSORIES

### COMBINATION CEILING SUPPLY AND RETURN DIFFUSERS

#### STEP-DOWN CEILING DIFFUSER

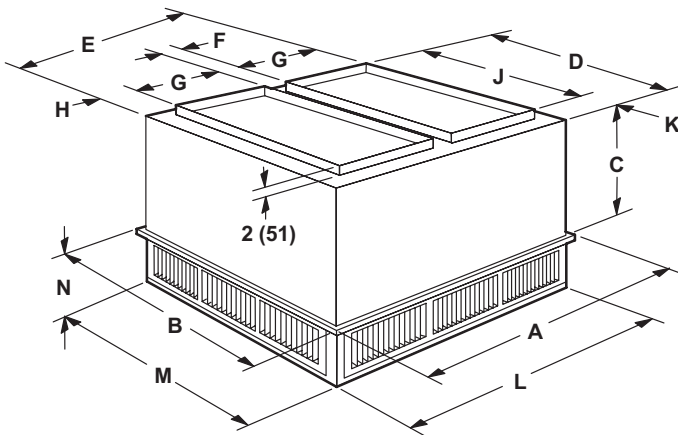

#### FLUSH CEILING DIFFUSER

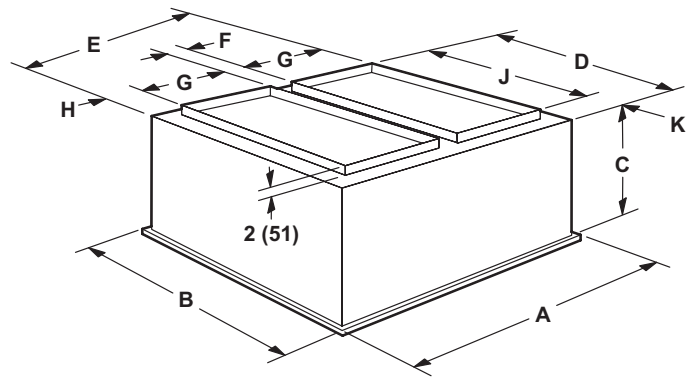

Model		RTD11-185S	RTD11-275S
A	in.	47-5/8	59-5/8
	mm	1210	1514
B	in.	47-5/8	59-5/8
	mm	1210	1514
C	in.	24-5/8	30-5/8
	mm	625	778
D	in.	45-1/2	57-1/2
	mm	1156	1461
E	in.	45-1/2	57-1/2
	mm	1156	1461
F	in.	4-1/2	4-1/2
	mm	114	114
G	in.	18	24
	mm	457	610
H	in.	2-1/2	2-1/2
	mm	64	64
J	in.	36	48
	mm	914	1219
K	in.	4-3/4	4-3/4
	mm	121	121
L	in.	45-1/2	57-1/2
	mm	1156	1461
M	in.	45-1/2	57-1/2
	mm	1156	1461
N	in.	10-1/8	11-1/8
	mm	257	283
Duct Size	in.	18 x 36	24 x 48
	mm	457 x 914	610 x 1219

Model		FD11-185S	FD11-275S
A	in.	47-5/8	59-5/8
	mm	1210	1514
B	in.	47-5/8	59-5/8
	mm	1210	1514
C	in.	29-1/4	35-1/4
	mm	743	895
D	in.	45	57
	mm	1143	1148
E	in.	45	57
	mm	1143	1448
F	in.	4-1/2	4-1/2
	mm	114	114
G	in.	18	24
	mm	457	610
H	in.	2-1/4	2-1/4
	mm	57	57
J	in.	36	48
	mm	914	1219
K	in.	4-1/2	4-1/2
	mm	114	114
Duct Size	in.	18 x 36	24 x 48
	mm	457 x 914	610 x 1219

## REVISIONS

Sections	Description of Change
Optional Conventional Temperature Control Systems	Removed Sysbus System Cable - Product discontinued.



Visit us at [www.Lennox.com](http://www.Lennox.com)

For the latest technical information, [www.LennoxCommercial.com](http://www.LennoxCommercial.com)

Contact us at 1-800-4-LENNOX

NOTE - Due to Lennox' ongoing commitment to quality, Specifications, Ratings and Dimensions subject to change without notice and without incurring liability. Improper installation, adjustment, alteration, service or maintenance can cause property damage or personal injury. Installation and service must be performed by a qualified installer and servicing agency.

©2026 Lennox Industries, Inc.