



**INSTALLATION INSTRUCTIONS FOR  
MODELS PCO3S-14-16-02, PCO3S-16-16-02, AND PCO3S-20-16-02**

THIS MANUAL MUST BE LEFT WITH THE OWNER FOR FUTURE REFERENCE



**! WARNING**

Improper installation, adjustment, alteration, service or maintenance can cause property damage, personal injury or loss of life. Installation and service must be performed by a licensed professional HVAC installer or equivalent, service agency, or the gas supplier.

**! WARNING**

Electric shock hazard.  
Can cause injury or death.  
Disconnect all electrical power supplies before servicing. Access panels must be in place during appliance operation.

**Table of Contents**

<b>Shipping and Packing List</b> .....	<b>2</b>	<b>Lennox Communicating Thermostat Setup</b> .....	<b>10</b>
<b>Models</b> .....	<b>2</b>	<i>System Setup (Commissioning)</i> .....	10
<b>Application</b> .....	<b>2</b>	<i>Reminders</i> .....	10
<b>Parts Identification, Dimensions and Specifications</b> .....	<b>3</b>	<i>Adding PureAir S to Existing System</i> .....	10
<b>Installation Examples</b> .....	<b>5</b>	<b>Dealer Control Center or Support Service</b>	
<b>Installation</b> .....	<b>6</b>	<b>Control Center</b> .....	<b>10</b>
<i>Unique Field-Supplied Installation Items</i> .....	6	<i>Notifications (Alert Codes)</i> .....	11
<i>Selecting Location</i> .....	6	<i>Tests and Diagnostics Function</i> .....	11
<i>Installing Cabinet</i> .....	6	<i>Installation Report</i> .....	11
<i>Installing UVA Lamp</i> .....	6	<b>Alert Codes</b> .....	<b>11</b>
<i>Installing UVA Lampholder</i> .....	7	<i>Soft Disable</i> .....	11
<i>Installing Air Filter</i> .....	7	<i>Alert Code Types</i> .....	12
<b>Wiring</b> .....	<b>8</b>	<b>Operation</b> .....	<b>17</b>
<i>Terminals and Wiring Recommendations</i> .....	8	<b>Filter, UVA Lampholder / PCO Cartridge and UVA Lamp Replacement</b> .....	<b>17</b>
<i>Communicating Wiring Diagrams</i> .....	8	<b>Annual Maintenance Kits</b> .....	<b>17</b>
<i>Minimizing Electrical Noise</i> .....	9	<b>Replacement Parts</b> .....	<b>17</b>
<i>Communication Wiring Routing</i> .....	9	<i>Removing and Installing UVA Lamp, Lampholder and Air Filter</i> .....	18
<i>PureAir S Internal Factory Wiring</i> .....	9	<i>Proper Clean-Up of Broken UVA Lamp</i> .....	18
<b>Communicating Control Functions</b> .....	<b>9</b>	<b>Troubleshooting Flow Chart</b> .....	<b>19</b>
<i>PCO Model (H2) Jumpers</i> .....	9		
<i>Change Lamp Reset (SW1)</i> .....	10		
<i>Change Filter Reset (SW2)</i> .....	10		
<i>HVAC Equipment Reset</i> .....	10		

## Shipping and Packing List

Assembled **PureAir S** air purification system which includes:

- Cabinet (1)
- UVA Lampholder / PCO cartridge (secure to interior of cabinet) (1)
- UVA lamp in box (secure to interior of cabinet) (1)
- Healthy Climate® Carbon Clean 16® Filter (located in interior of cabinet) (1)
- UVA lamp socket with 4-pin male connector assembly attached to light ballast electrical connector (1)
- Lennox Communication Control interface.
- Literature bag includes power cord (120VAC)<sup>1</sup>, installation instruction, UVA Lamp Socket brass finger nuts (2), UVA Lampholder / PCO cartridge wing nuts (2) and warranty.

<sup>1</sup>230VAC power cord available separately (part number 91X44).

Check equipment for shipping damage. If damage is found, immediately contact last carrier.

## Models

Table 1. Unit Catalog Numbers

Model	Catalog Number
PCO3S-14-16-02	Y8905
PCO3S-16-16-02	Y8904
PCO3S-20-16-02	Y8903

## Application

The **PureAir S** air purification system uses photocatalytic oxidation (PCO) technology to reduce levels of airborne volatile organic compounds, cooking odors, common household odors, airborne dust particles, mold spores and pollen. Each unit may be connected to either 120VAC or 230VAC power supply.

Lab tests confirm a 50% reduction in total volatile organic compounds (TVOC) within the first 24 hours of initial operation of the **PureAir S** air purification system. It may take up to 48 hours after initial system start-up to reduce the airborne chemicals that have built up in a home over a long period of time.

For peak performance, unit should be installed in homes with TVOC levels that are less than 1000 micro-gram / cubic meter. Home source removal and ventilation may be required to lower total volatile organic compounds to this level.

The Healthy Climate® Carbon Clean 16® Filter combines industry-leading MERV 16 filtration and carbon-coated fiber matrix.

For full feature benefits, the PureAir S must be used with any S30 or S40 Thermostat and communicating indoor unit.

The S30 Thermostats will require firmware version 3.4 or higher to take advantage of all of the PureAir S features.

New features included are:

- 4-wire connection to Lennox communicating indoor unit control
- Using sensors to:
  - > Automatically detect dirty air filter
  - > Display air filter life percentage
  - > Monitor UVA lamp operational state (On or Off).
  - > Display UVA lamp life percentage

## ! IMPORTANT

Oil on metal ducts may cause odors.

Use a mild soap and water solution to remove oils from transitions and duct surfaces prior to installation.

## ! IMPORTANT

Do not use any form of silicone sealant.

Use of silicone-based products will reduce the effectiveness of, or damage the titanium dioxide coatings on the PCO cartridge.

## ! IMPORTANT

Route power cord away from traffic areas where the cord may become a safety hazard.

## ! IMPORTANT

UVA lamp life is shortened when lamp is turned off and on. Power to unit must remain on at all times.

Do not interlock lamp operation with air handler blower operation.

## ! CAUTION

Ultraviolet (UVA) radiation risk.

Prolonged exposure may cause skin or eye damage.

Avoid prolonged (weeks) exposure to skin or eyes.

## ! WARNING

Risk of carbon monoxide poisoning.

Can cause injury or death.

Do not operate system unless access panel is in place and properly secured. Operation of this equipment without the access panel in place may cause exhaust fumes to be drawn into occupied spaces.

## ! CAUTION

Sharp edges hazard.

Sharp edges can cause injuries.

Use protective gloves when grasping equipment edges.

# Parts Identification, Dimensions and Specifications

## PARTS IDENTIFICATION

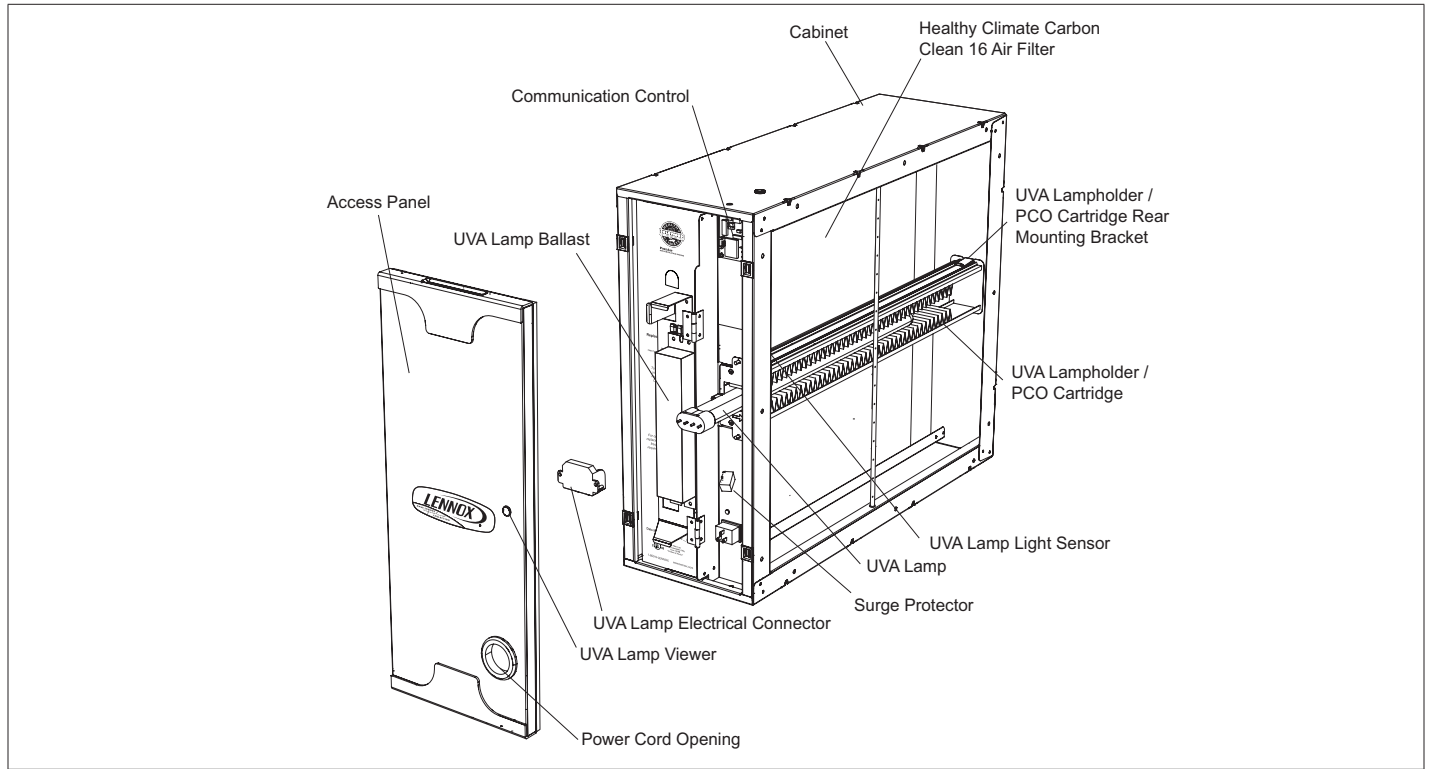

Figure 1. Parts Identification

## DIMENSIONS

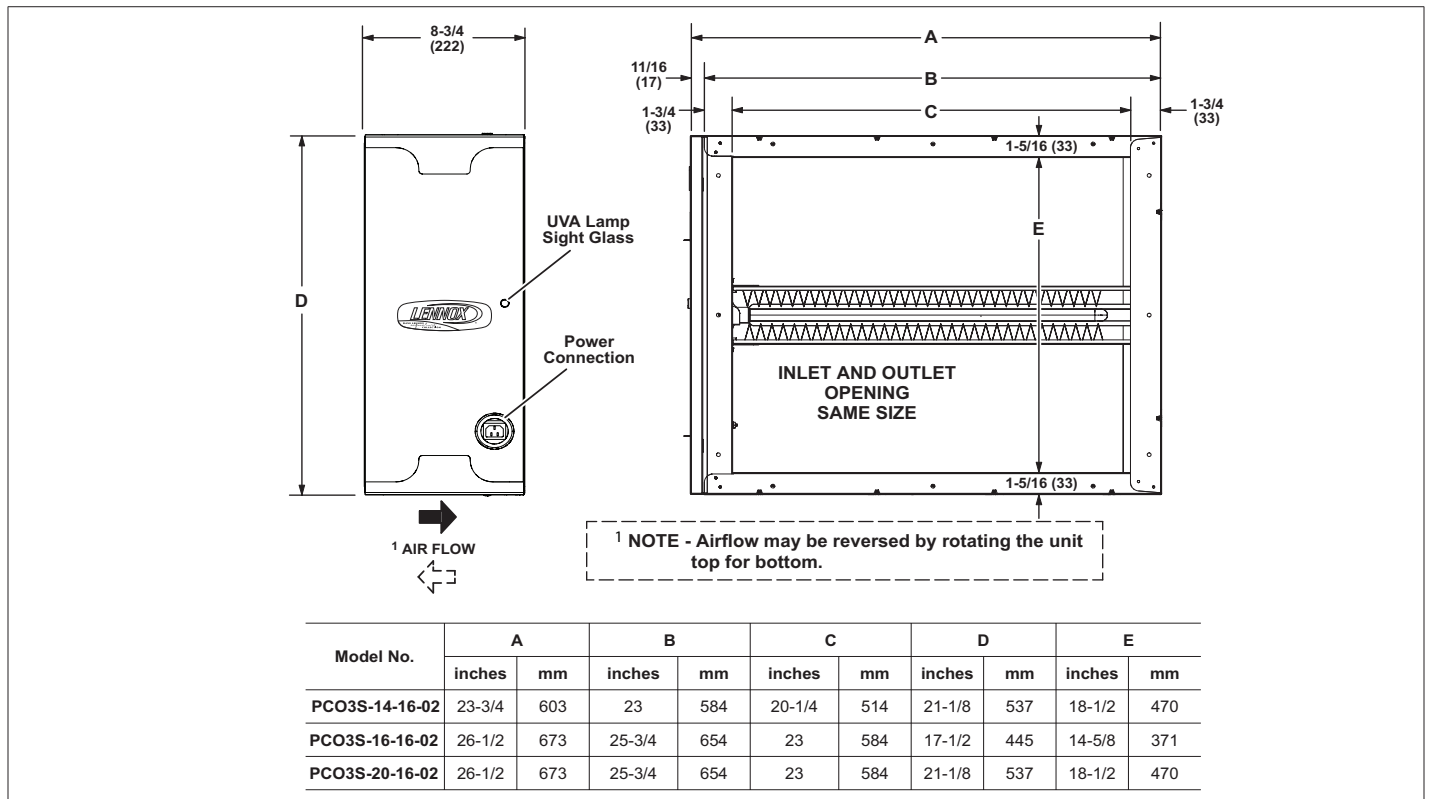

Figure 2. Dimensions

## SPECIFICATIONS

**Table 2. Specifications**

Model	Weight (lbs.)	Electrical	Power Consumption	Operating Environment	Pleated Filter Efficiency	Listings
PCO3S-14-16-02	24	120V, 50/60 Hz, 0.49 Amps -- Maximum or 230 V, 50/60 Hz, 0.26 Amps -- Maximum	120VAC and 230VAC - 58 Watts Nominal	0°F to 140°F outside of duct 10 to 60 percent relative humidity (Optimal performance at 50 percent relative humidity)	Minimum Efficiency Rating Value (MERV) 16	ETL safety listing report 102535818DAL- 001. Conforms to UL 60335-1, UL 60335-02-40. Certified to CSA C22.2#60335-1, CSA C22.2#60335- 2-40.
PCO3S-16-16-02	27					
PCO3S-20-16-02	27					

**Table 3. Approximate Air Flow Resistance (Cabinet and Filter)**

Capacity (Tons)	Flow Rate (CFM)	Pressure Drop (in. w.g.)		
		PCO3S-14-16-02	PCO3S-16-16-02	PCO3S-20-16-02
Low / Variable	400	0.05	0.04	0.03
Low / Variable	600	0.07	0.07	0.06
2	800	0.11	0.11	0.08
2.5	1000	0.15	0.15	0.11
3	1200	0.20	0.20	0.15
3.5	1400	0.25	0.25	0.18
4	1600	*	0.31	0.22
4.5	1800	*	*	0.27
5	2000	*	*	0.31

\*Not recommended. Excessive system pressure drop can damage HVAC system and reduce performance.

### IMPORTANT

Do not wash UVA Lampholder / PCO cartridge. Soap and water will destroy the titanium dioxide catalyst that coats the cartridge surface.

### IMPORTANT

Unpacking required.  
Remove all protective packing material from the UVA lamp (taped to the cabinet) and the titanium dioxide PCO cartridge.  
Packing material should be disposed of properly.

### IMPORTANT

Possible odor emissions. Chemical reactions may cause temporary odors after initial start-up or after lamp replacement. Odor may also be present after paint, cleaning solutions or hobby materials have been used in the conditioned space.  
Some occupants may experience irritation or discomfort during this period. If the irritation or discomfort lasts longer than 48 hours, the homeowner should be advised to contact a Lennox dealer.

### IMPORTANT

The cabinet should be installed so that the UVA lamp will be in the horizontal position.

### IMPORTANT

This system is NOT intended to be used for removal of active mold growth or continuous sources of high levels of chemicals in the air.  
For existing mold growth, the mold must be properly removed PRIOR to installation of the PureAir S air purification system.

### IMPORTANT

This appliance is intended for return air duct installation only.  
Improper installation may damage PureAir S air purification system, HVAC system, or other equipment and may also void warranty.

### CAUTION

UVA Lamp contains mercury.  
Ingestion of or contact with mercury or mercury vapor is hazardous to your health.  
Take care when handling UVA lamp. If UVA lamp is broken, avoid contact with mercury.

### IMPORTANT

Healthy Climate® Carbon Clean 16® Filter cannot tolerate direct exposure to UVA light.  
Filter is protected by PCO cartridge shield.

# Installation Examples

## UPFLOW FURNACE/AIR HANDLER (Bottom Return Air)

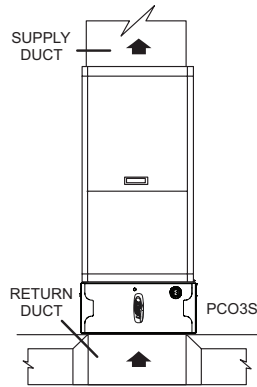

## UPFLOW FURNACE (Side Return Air - up to 4 ton)

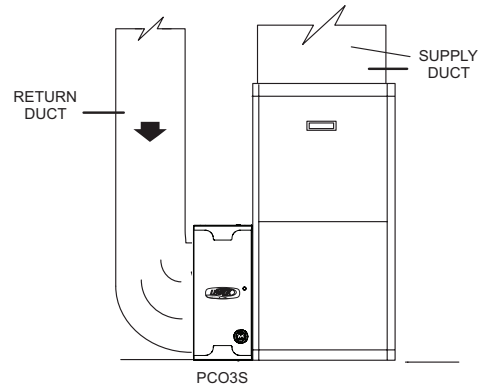

## DOWNFLOW FURNACE/AIR HANDLER

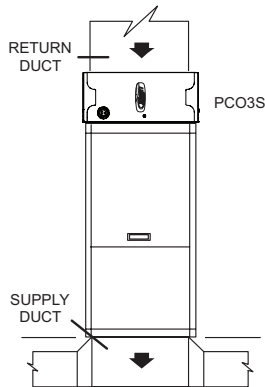

## UPFLOW FURNACE (Option 1 - Side Return Air - 5 ton) (With Optional RAB Return Air Base)

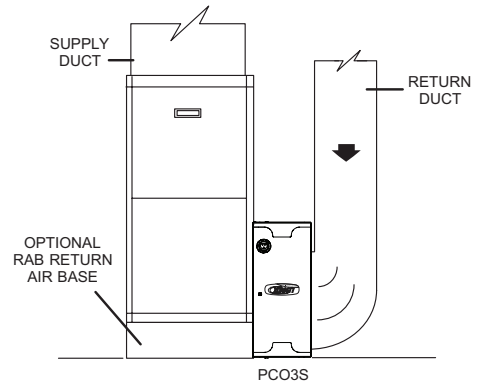

**NOTE:** Lennox badge can be rotated 180 degrees for this application.

## HORIZONTAL FURNACE/AIR HANDLER

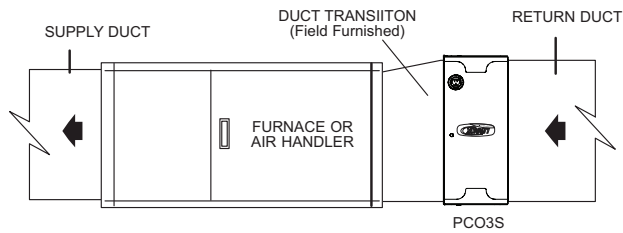

**NOTE:** Lennox badge can be rotated 180 degrees for this application.

## UPFLOW FURNACE (Option 2 - Side Return Air - 5 ton) (Modified Return Air Opening)

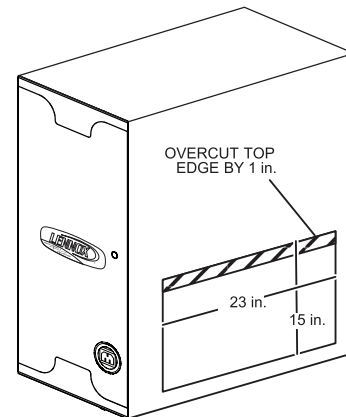

**Figure 3. Installation Examples**

## Installation

### UNIQUE FIELD-SUPPLIED INSTALLATION ITEMS

The following items are recommended to have on-hand for installation of the unit.

- Cotton gloves and cloth (to remove finger prints from UVA lamp)
- Aluminum foil tape or water-based mastic (NOT silicone) to be applied as a sealant.

### SELECTING LOCATION

The unit must be installed in the return air duct upstream of the supply blower. Allow a 30" (76cm) service clearance in front of the access panel as shown in figure 4. The air filter and UVA Lampholder / PCO cartridge must be removable.

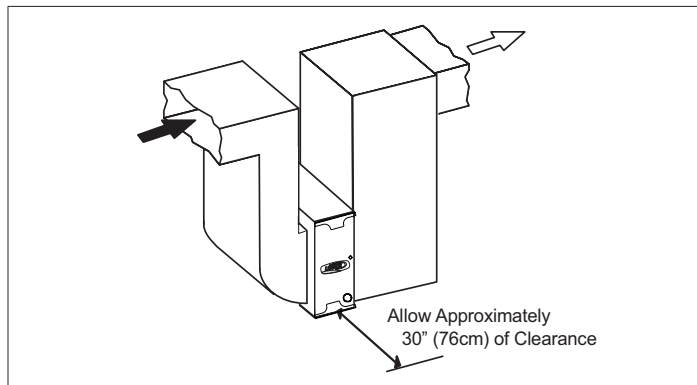

Figure 4. Service Clearance

### INSTALLING CABINET

The cabinet may either be installed on a level installation deck or platform adjacent to the air handler or it may be suspended from the rafters using metal strapping. If straps are used, take care when attaching straps to the cabinet. Ensure fasteners do not interfere with internal components of the cabinet. The air filter and UVA Lampholder / PCO cartridge must be able to slide freely into the cabinet.

1. Locate and remove the UVA Lampholder / PCO cartridge from the cabinet.

**NOTE:** Oil on metal surfaces may cause odors. Use mild soap and water solution to wash all new duct and transition surfaces.

2. Use the air flow directional label on the inside of the UVA Lampholder / PCO cartridge to orient the unit.
3. Properly position the cabinet next to the return air opening of the air handling unit. Use sheet metal screws 1" (25mm) maximum length, rivets or other appropriate fasteners to secure cabinet to the return air side of the air handling unit.
4. Use field-provided sheet metal screws 1" (25mm) maximum length to fasten the return air duct to the other side of the cabinet. Attachment holes are provided in housing.

5. Use field-provided aluminum foil tape or water-based mastic to seal all joints between the cabinet, air handler and duct.
6. In high humidity applications, wrap cabinet with field-provided 2" (50mm) foil-faced insulation (foil on the outside) to prevent condensation.

### INSTALLING UVA LAMP

Use cotton gloves or a cotton cloth to protect the lamp and your hands during unpacking and installation.

1. Remove cabinet access panel.
2. The UVA Lampholder / PCO cartridge is shipped in a protective packaging. Packaging must be removed prior to installation. Take care to prevent damage while removing from packaging.
3. Locate the UVA lamp box, which is taped to the inside of cabinet and carefully remove. Set UVA lamp box aside while preparing cabinet for UVA lamp installation.
4. Remove (slide out) Healthy Climate® Carbon Clean 16® Filter from cabinet.
5. Disconnect the lampholder cable assembly from the UVA lamp ballast connector.
6. Carefully remove lamp from UVA lamp box and secure the UVA lamp electrical connector to the UVA lamp by sliding the UVA lamp pins into the slot. Proper connection will make a snapping sound.

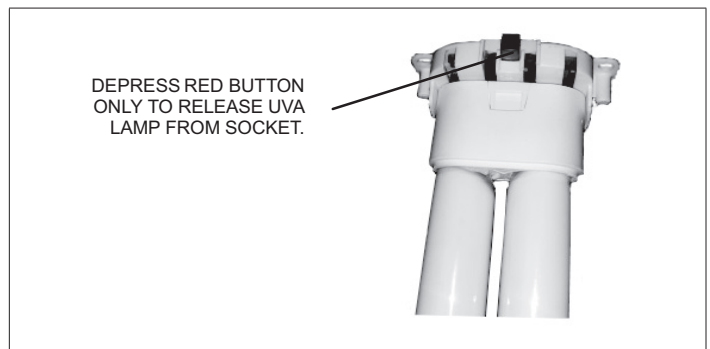

Figure 5. Releasing UVA Lamp from Socket

7. Slide the UVA lamp into UVA Lampholder / PCO cartridge. Verify that the UVA lamp is secure to the one metal UVA lamp clamp located mid-way on the UVA lamp reflector.

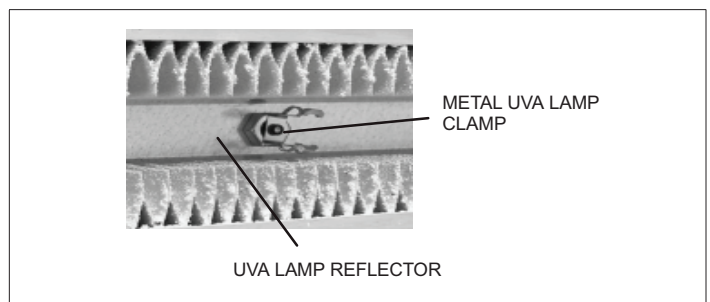
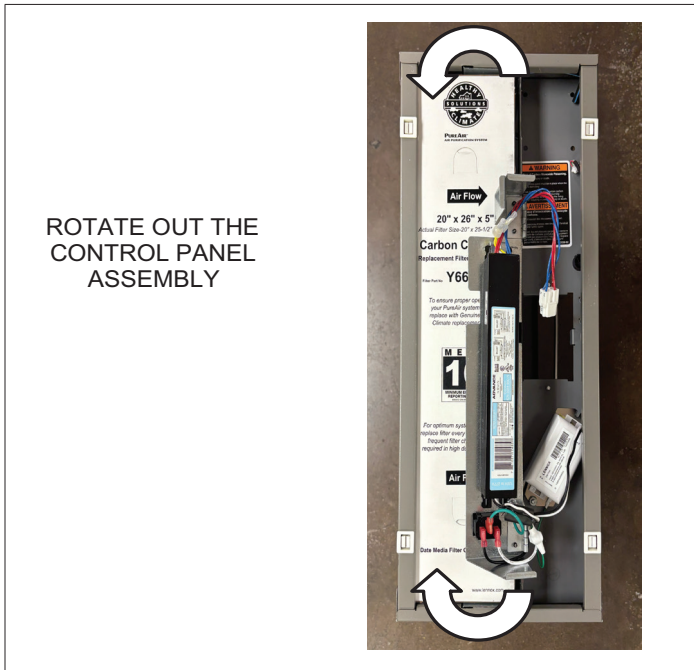

Figure 6. UVA Lamp Metal Clamp

- Rotate the hinged control panel assembly out.



**Figure 7. Rotate Out Control Panel Assembly**

- Thread the UVA Lampholder / PCO cartridge two posts through the UVA lamp connector's two holes.
- Fasten the lamp socket to the UVA Lampholder / PCO cartridge using the two-brass finger nuts located in the literature bag.

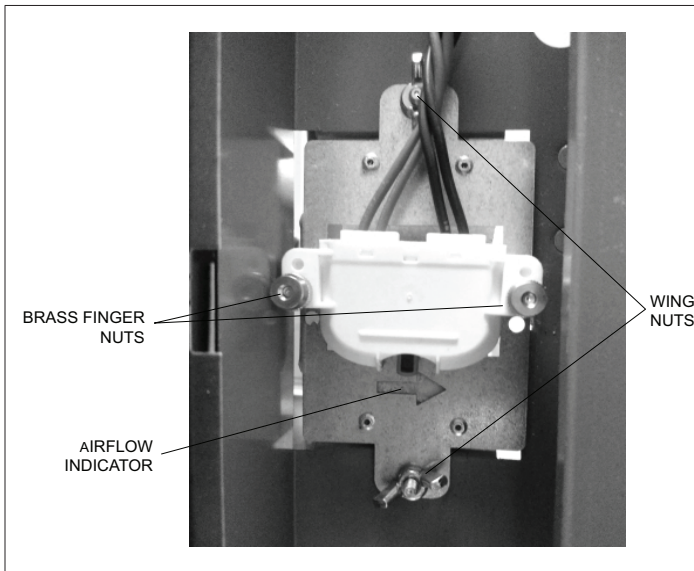

**Figure 8. Brass Finger and Wing Nuts**

## INSTALLING UVA LAMPHOLDER

Use the following procedure to install the UVA Lampholder / PCO cartridge.

- While aligning, slide the UVA Lampholder / PCO cartridge into case rails and align with rear mounting bracket.
- Secure the UVA Lampholder / PCO cartridge to the two frame screw posts using the provided wing nuts (2).

**NOTE:** There is an arrow on the front of the component indicating the correct way to install it.

- Connect UVA lamp 4-pin male connector to ballast female 4-pin connector.

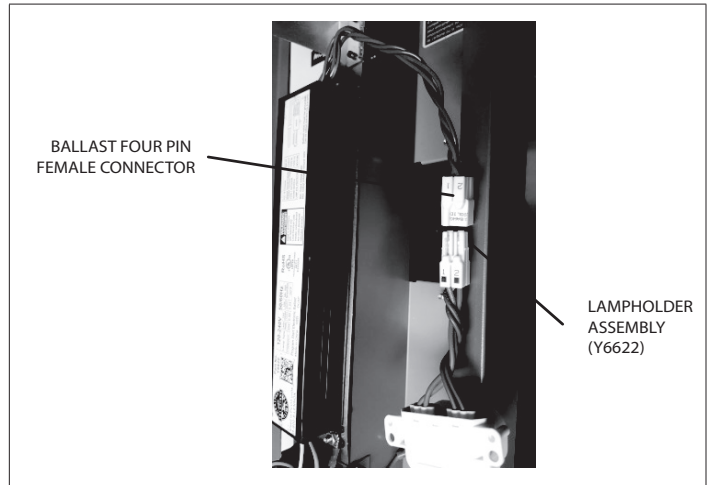

**Figure 9. Ballast 4-Pin Female Connector**

- Rotate hinged control panel assembly back into the cabinet. Make sure no wiring is being pinched.

## INSTALLING AIR FILTER

Use the following procedure to install the air filter.

- Slide the Healthy Climate® Carbon Clean 16® Filter into the rails on the air inlet side of the cabinet. Verify proper airflow direction.
- Securely fasten the access panel.
- Plug one end of the provided power cord into the receptacle on the cabinet and the other end into a power receptacle.
- Look through the view port in the access panel to check that the UVA lamp is illuminated.

**NOTE:** On initial start-up, the UVA lamp may not reach full illumination for several minutes.

# Wiring

## TERMINALS AND WIRING RECOMMENDATIONS

**Table 4. Terminal Designations and Wiring Recommendations**

Terminal Designation	Description	Recommended Thermostat Wiring
R	24VAC input	18AWG unshielded
C	24VAC return	
I+	RS-BUS I+	18 - 22AWG shielded or unshielded
I-	RS-BUS I-	

## COMMUNICATING WIRING DIAGRAMS

There may be situations where alternate wiring methods may need to be employed. Two options are available to address an inductive voltage issue. If Alert Code 105 is still present after following troubleshooting Steps 1 and 2 then proceed to Step 3 wiring options 2 or 3.

- **Option 2** - Using shielded 2-conductor cable between the indoor, outdoor and thermostat -i and +i terminals may be required.
- **Option 3** - Using unshielded 2-conductor cable between the indoor, outdoor and thermostat -i and +i terminals may be required.

**NOTE:** When using multi-conductor unshielded thermostat cable, refer to "Figure 13. Minimizing Electrical Noise" on page 9.

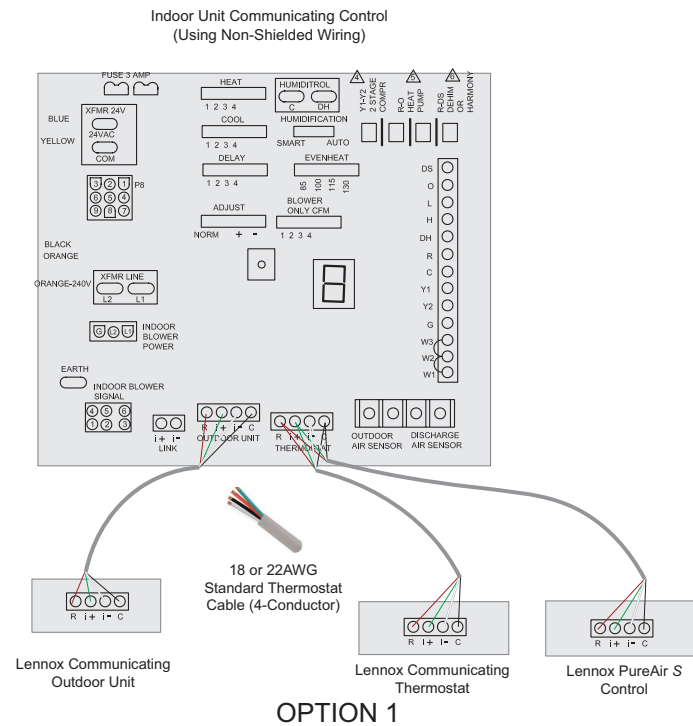

**Figure 10. Lennox Communicating System Wiring Connections (Option 1)**

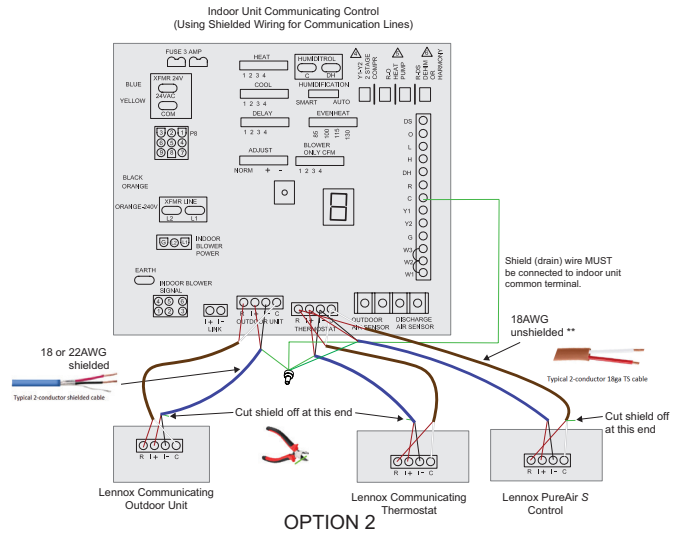

**Figure 11. Lennox Communicating System Wiring Connections (Option 2)**

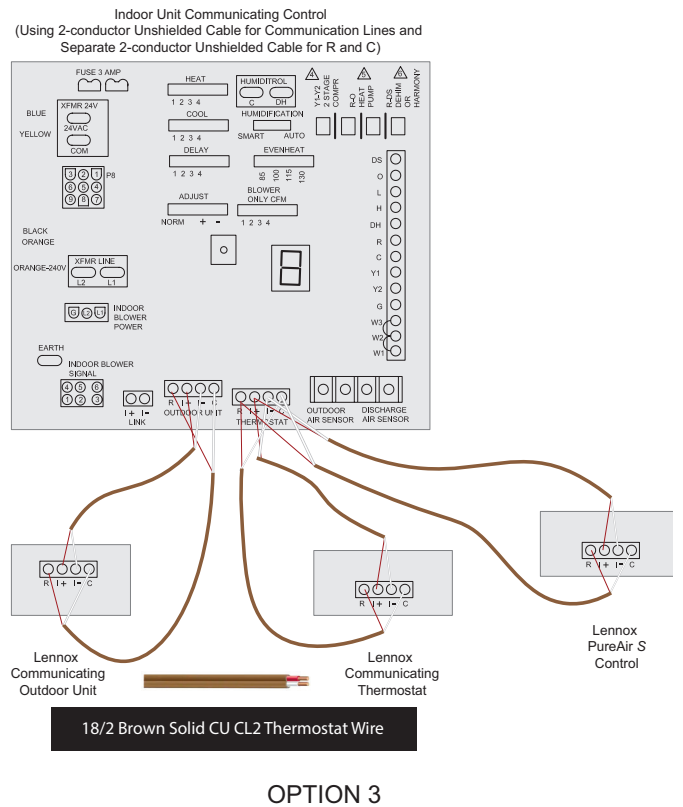

**Figure 12. Lennox Communicating System Wiring Connections using Separate Unshielded Cable (Option 3)**

## MINIMIZING ELECTRICAL NOISE

When using multi-conductor unshielded thermostat cable, to minimize electrical noise, cap unused wires as illustrated below and run to indoor unit C terminal.

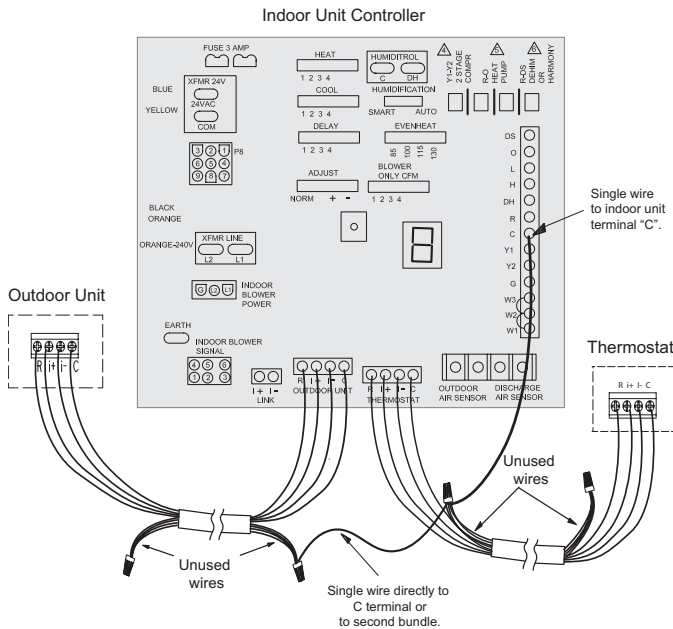

Figure 13. Minimizing Electrical Noise

## COMMUNICATION WIRING ROUTING

Communication wiring to the indoor unit is routed through the opening in the top of the cabinet as illustrated below.

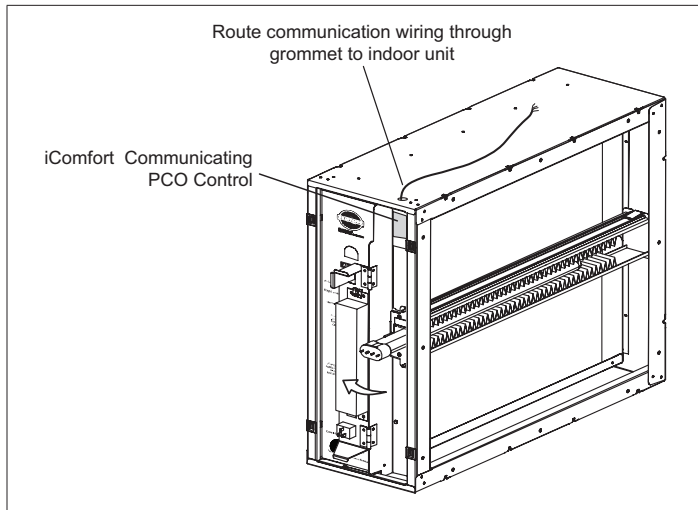

Figure 14. Routing of Communication Wiring

## PUREAIR S INTERNAL FACTORY WIRING

The PCO should be wired in accordance with national and local codes.

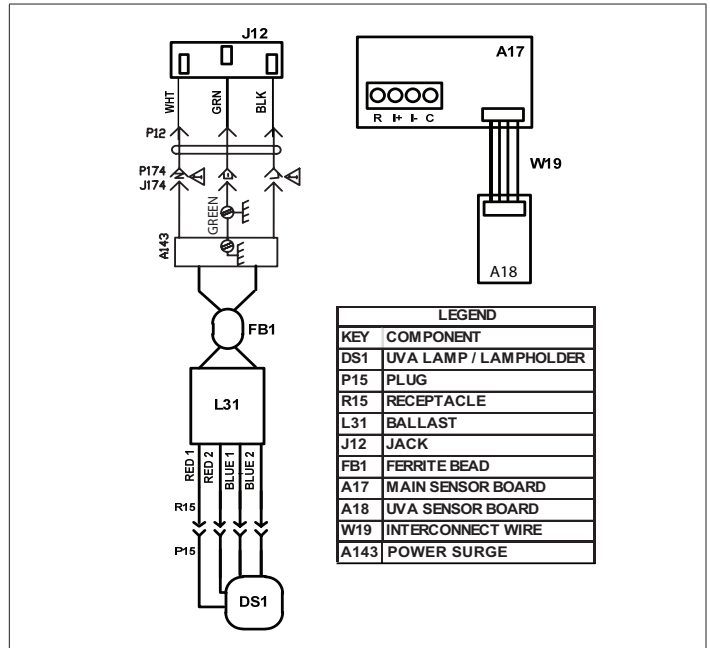

Figure 15. PCO Wiring Schematic

## Communicating Control Functions

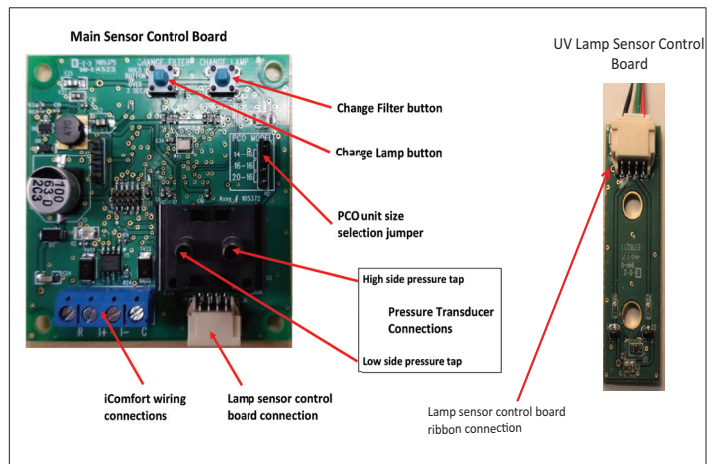

Figure 16. PureAir S Communicating Control

## PCO MODEL (H2) JUMPERS

A series of jumpers is used to select which size pure air the control is installed.

Jumper selections are:

- Position 1 (pins 1 and 2 shorted): 14-16 (nominal airflow = 1400cfm)
- Position 2 (pins 2 and 3 shorted): 16-16 (nominal airflow = 1600cfm)
- Position 3 (pins 3 and 4 shorted): 20-16 (nominal airflow = 2000cfm)

**NOTE:** The correct size selection should already be set from the factory.

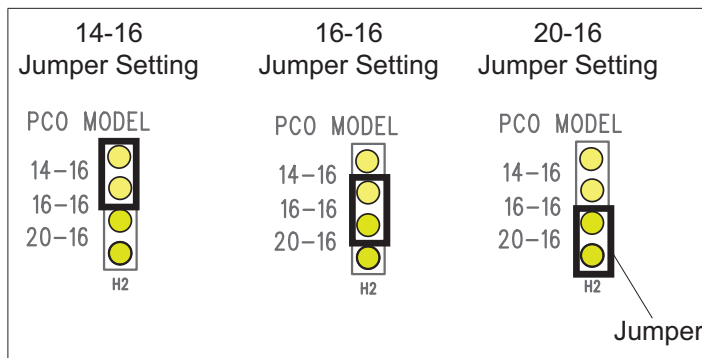

Figure 17. Model Jumper Selection

### CHANGE LAMP RESET (SW1)

After bulb replacement, press and hold for three seconds SW1 - Change Lamp button. This resets the system.

A LED will start to flash after three seconds to indicate the reset was successful.

### CHANGE FILTER RESET (SW2)

After air filter replacement, press and hold for three seconds SW2 - Change Filter. This resets the system.

A LED will start to flash after three seconds to indicate the reset was successful.

### HVAC EQUIPMENT RESET

When pressing both the SW1 and SW2 switches at the same time for ten seconds will reset the control to factory default.

Control can also be reset by using the Lennox communicating thermostat. Go to **menu > settings > advanced settings > view dealer control center or View Support Service Control Center > equipment (Settings) > reset > reset HVAC equipment.**

## Lennox Communicating Thermostat Setup

### SYSTEM SETUP (COMMISSIONING)

During the initial or rerunning the commissioning of the system using the a Lennox communicating thermostat, the system will auto-detect the presence of the **PureAir S** unit.

Follow the instructions provided with the thermostat for the system commissioning process. If the PureAir S component is successfully detected, it will appear on the found equipment screen.

**NOTE:** During commissioning the blower will turn on and run at three different CFM settings for the PCO filter calibration to take place. This may be well in advanced before the display is fully up and running. This is a normal process. The blower may run as long as 90 seconds at each CFM setting to complete the filter calibration.

### REMINDERS

Default setting is sensor-based. Additional options are calendar time, run-time or disabled. On the reminder screen, select **PureAir S** maintenance to change the option.

### ADDING PUREAIR S TO EXISTING SYSTEM

Once the **PureAir S** accessory has been installed and system powered up, go to the thermostat. From the thermostat to go to **menu > settings > advanced settings > (dealer control center or View Support Service Control Center) > equipment (Settings)** and select **reset**. From the reset list, select **re-configure system**. This will tell the system to reboot and search for new equipment attached to the system.

Follow the commissioning screens to the equipment found screen, verify that the **PureAir S** accessory has been detected and added to the system.

### Dealer Control Center or Support Service Control Center

The Dealer Control Center menu provides access for the installer or service technician to perform various functions. Advance equipment configurations, notifications, tests, diagnostics, installation reports and general information about the system. **menu > settings > advanced settings > (view dealer control center or View Support Service Control Center) > equipment or Equipment Settings).**

## PUREAIR S EQUIPMENT PARAMETERS

The following is a complete list of all possible parameters listed under **System**. Parameters actually available are dependent on the Lennox communicating equipment type detected and non-communicating equipment added.

From the Dealer Control Center Screen, go to **menu > equipment > PureAir** or **Menu > Settings > PureAir**. There you will find the applicable parameter settings for PureAir S.

**Table 5. PureAir S Parameters**

Parameter	Description
Equipment	PureAir Filter
Dirty Filter and UV Life Detection	<p>Default: ON. Options are either ON or OFF. Alarms 503 and 504 will not be displayed when this parameter is set to OFF. The diagnostics screen on the thermostat will continue to show values for both filter life and UV lamp life regardless of the value of this parameter.</p> <ul style="list-style-type: none"> <li>This parameter turns on and off the filter life and UV lamp life reporting. When set to off, the control will continue to calculate the remaining filter life through continuous sampling, but will not use filter tests to determine filter life. The control will:</li> <li>Perform a UV lamp calibration upon indication of a lamp change regardless of the value of this parameter.</li> <li>Will calculate UV lamp life remaining regardless of the value of this parameter.</li> </ul>
Max Air Filtered between Tests	<p>Default is 100%, Range is 50% to 100% Changes can be made in increments of 10%. This parameter modifies the amount of air that is allowed to pass through the filter after a valid % life determination before a filter test is initiated. This parameter is expressed as a percentage of the cubic feet of air that would pass through the filter if the fan operated at continuous fan CFM for 30 days.</p>
UV lamp operation detection	Default: ON. Options are either ON or OFF.
Filter Life	Provides percentage of remaining filter life. This is for display purposes only and cannot be changed.
Last replacement date for filter	Date last filter reset was accomplished. This is for display purposes only and cannot be changed
Purifier life	Provides percentage of remaining purifier life. This is for display purposes only and cannot be changed <b>NOTE:</b> Purifier life is referring to the UVA Lamp / PCO cartridge insert.
Last replacement date for purifier insert	Date last purifier insert reset was accomplished. This is for display purposes only and cannot be changed
<ul style="list-style-type: none"> <li>Reset <b>PureAir S</b> will reset all <b>PureAir S</b> parameters back to factory defaults.</li> <li>Reset purifier insert will reset (<b>recalibration</b>) it to 100%. This is usually accomplished after the UVA Lamp / PCO cartridge insert has been replaced.</li> <li>Reset filter will reset (<b>recalibration</b>) it to 100%. This is usually accomplished after the air filter has been replaced.</li> </ul>	

## NOTIFICATIONS (ALERT CODES)

The thermostat's notification screens provide information on active notifications and previously cleared notifications. When selecting either a cleared or active notification a brief description and alert code will be displayed. Notifications are categorized by system, indoor unit (air handler or furnace), outdoor unit (air conditioner or heat pump), zoning control (if installed) and thermostat.

## TESTS AND DIAGNOSTICS FUNCTION

There are no installer tests or diagnostic features available for the **PureAir S** accessory.

## INSTALLATION REPORT

**PureAir S** accessory information includes equipment name, model number, serial number and firmware version.

In addition, when selecting **PureAir S**, filter life, last replacement date for filter and purifier life and last replacement date for purifier information is available.

## Alert Codes

### SOFT DISABLE

Soft disabling is when the thermostat finds an unknown control on the system communication bus. The thermostat sends the unknown control a message to go into soft disable mode until the component is properly configured or removed.

The thermostat will not show any code for a soft disabled control. When soft disabling occurs only the control that has been disabled will display the blinking LED status. Refer to the device's installation and setup guide for further guidance.

Confirm proper wiring between all devices such as thermostat, **PureAir S** and Smart Hub.

Cycle power to the **PureAir S**.

- Go to the **menu > settings > advanced settings > view dealer control center or View Support Service Control Center**). Touch **proceed** to continue.
- Select **equipment**.
- Touch **reset**.

## ALERT CODE TYPES

---

To expand a specification notification to access a more detail description of the alert code, press the down arrow to expand the description.

- **Service Urgent** alerts are displayed on Home (user) screen under the homeowner and installer alert buttons. **Service Urgent** means that a service call is needed to get the system running.
- **Service Soon / Service Urgent** means that the system will likely recover on its own and no interaction is necessary. Typically, either after a specific timer period or a specific number of instances, some **Service Soon** alerts will escalate to **Service Urgent**.
- **Service Soon** alerts are found only in under the installer alert button.
- **Information Only-Dealer** is information only and helps Lennox interpret test results and understand complicated behaviors. **Information Only** are not reported to homeowner or dealer.

**NOTE: Communication System:** *When communication controls are operating in a communication system, all jumpers and links setting on the controls are ignored. Jumpers and links setting are treated as defaults and would only be active if the system was configured as a non-communicating system.*

**Table 6. Alert Codes and Troubleshooting**

GF= Gas Furnace, AH=Air Handler, ID=Indoor unit (GF or AH), HP=Heat Pump, AC=Air Conditioner, OD=Outdoor Unit (AC or HP), PA=Pure Air S, ZA=Zone system and TS=Thermostat

Alert Code	Priority Condition	Actual Displayed Alert Text Under dealer control center > Notifications	Component or System Operational State and Troubleshooting Tip	How to clear alert code
105	Service Urgent	Communication Problem	<p>Low voltage wiring between one of the systems components has been compromised. The System component (device) is unable to communicate.</p> <ul style="list-style-type: none"> <li>• <b>Thermostat - Open Dealer Service Center</b> - Select the notification icon, select <b>All</b>, review alert code details to determine which device's low voltage wiring is experiencing a communication issue. Review both active and cleared alerts.</li> <li>• <b>Lennox Smart Technician or iComfort Dealer Setup apps</b> - Select the Notifications icon, select <b>All</b>, review alert code details to determine which device's low voltage wiring has the communication problem. Review both active cleared alerts.</li> </ul> <p><b>Step 1 Troubleshooting:</b></p> <p><b>In most issues can be resolved by taking the following actions:</b></p> <ul style="list-style-type: none"> <li>• Make Sure all unused wires are tied together and taken back to the <b>C</b> terminal on the indoor board as shown in the installation and setup guide. See "Figure 11. Minimizing Electrical Noise" on page 16 for the illustration on how to bundle unused wires.</li> <li>• Check for loose terminal connections on components (devices). Lennox recommends using a slotted screwdriver with a 3/32" (2.4 mm) tip.</li> <li>• Check for incorrectly wired or poorly spliced connections between components.</li> <li>• Verify that low voltage going to system components has been separated from high voltage wiring in wall, ceiling, &amp; floor cavities.</li> <li>• Check for proper grounding on the line voltage and low voltage wiring, transformer, and equipment.</li> </ul> <p>If Alert Code 105 is still present after performing the actions listed above proceed to <b>Step 2: Troubleshooting.</b></p> <p><b>Step 2 Troubleshooting:</b></p> <ul style="list-style-type: none"> <li>• Disconnect all wiring to other components (except thermostat and indoor unit) and reconnect one device at a time. Recommission system each time a device is added until wiring issue has been located.</li> <li>• Zoning: If a zoning system has been installed and is wired directly from the thermostat to the zoning control then disconnect wiring and run control wiring from the zoning control directly to the indoor unit control.</li> <li>• Float Switch: When using a float switch, use an isolation relay between the dedicated float switch terminals as illustrated in both the S30 and S40 Installation and Setup Guide. For testing purposes, remove float switch from circuit.</li> </ul>	Automatically clears when the system detects the issue no longer exists.

**Table 6. Alert Codes and Troubleshooting**

GF= Gas Furnace, AH=Air Handler, ID=Indoor unit (GF or AH), HP=Heat Pump, AC=Air Conditioner, OD=Outdoor Unit (AC or HP), PA=Pure Air S, ZA=Zone system and TS=Thermostat

Alert Code	Priority Condition	Actual Displayed Alert Text Under dealer control center > Notifications	Component or System Operational State and Troubleshooting Tip	How to clear alert code
105	Service Urgent	Communication Problem	<ul style="list-style-type: none"> <li>• Inductive voltage from surrounding sources. Check each wire in AC mode to <b>C</b> on circuit board.               <ul style="list-style-type: none"> <li>&gt; Good voltage is .03-.3VAC inductive voltage is not an issue.</li> <li>&gt; Acceptable can be up to .7VAC with moderate success.</li> <li>&gt; Some units have worked with up to 1.2VAC with occasional success.</li> <li>&gt; Voltage over 1.2VAC needs to be addressed.</li> </ul> </li> </ul> <p>If Alert Code 105 is still present after performing the actions listed above proceed to <b>Step 3: Troubleshooting.</b></p> <p><b>Step 3 Troubleshooting:</b></p> <p>New low voltage wiring will need to be ran to the system components. There are 2 options for replacing low voltage wiring:</p> <ul style="list-style-type: none"> <li>• <b>OPTION 2</b> - Utilizing 18/2 AWG for wires going to 24VAC (<b>R</b> and <b>C</b>) terminals and 18 or 22/2 AWG shielded wires going communicating terminals (i+ and i-).</li> <li>• <b>OPTION 3</b> - Utilizing two separate 18/2 AWG unshielded wires. One set wire to 24 VAC terminals (<b>R</b> and <b>C</b>) and one set to communicating terminals (i+ and i-).</li> <li>• See Communication Wiring Section in the Lennox S30 or S40 Smart Thermostat Installation and Setup Guide.</li> </ul>	Automatically clears when the system detects the issue no longer exists.
120	Service Soon	Unresponsive Device	<p>There is a delay in the system component responding to the system. Typically this alert code does not cause any operational issues and will clear on its own.</p> <ul style="list-style-type: none"> <li>• This alert code is usually caused by a delay in the outdoor unit responding to the thermostat.</li> <li>• Leaking voltage from strands within the bundle.               <ul style="list-style-type: none"> <li>&gt; Land only the <b>R</b> wire on the <b>R</b> terminal to load the bundle with 24VAC.                   <ul style="list-style-type: none"> <li>▶ Typically only the <b>R</b> wire needs to be landed to identify if voltage is leaking.</li> <li>▶ If voltage is present checking the other wires is informational only but not needed.</li> <li>▶ If voltage is not present checking the other wires one at a time would be needed.</li> </ul> </li> </ul> </li> <li>&gt; Check each loose wire in AC mode to <b>C</b> on circuit board.               <ul style="list-style-type: none"> <li>▶ Good voltage is .03 -.3VAC leaking voltage is not the issue.</li> <li>▶ Acceptable can be up to .7VAC with moderate success.</li> <li>▶ Some units have worked with up to 1.2VAC with occasional success.</li> <li>▶ Voltage over 1.2VAC needs to be addressed.</li> </ul> </li> </ul>	Automatically clears after an unresponsive system component (device) responds to any inquiry.

**Table 6. Alert Codes and Troubleshooting**

GF= Gas Furnace, AH=Air Handler, ID=Indoor unit (GF or AH), HP=Heat Pump, AC=Air Conditioner, OD=Outdoor Unit (AC or HP), PA=Pure Air S, ZA=Zone system and TS=Thermostat

Alert Code	Priority Condition	Actual Displayed Alert Text Under dealer control center > Notifications	Component or System Operational State and Troubleshooting Tip	How to clear alert code
124	Service Urgent	Tstat Lost Communication To Smarthub	<p>The thermostat has lost communication with a system component for more than three minutes. System component has lost communication with the thermostat.</p> <ul style="list-style-type: none"> <li>• Check the wiring connections between components.</li> <li>• Ohm wires.</li> <li>• Cycle power.</li> <li>• Any component that is miss-wired may cause a false component code to be shown on system component.</li> <li>• Disconnect all wiring to other system components and check communication one at a time.</li> </ul> <p><b>NOTE:</b> <i>When using a float switch, use isolation relay to break common wire to outdoor unit. For testing purposes, remove float switch from the circuit</i></p> <p>This alert code stops all associated system operations and waits for a heartbeat message from the system component that is not communicating.</p>	Automatically clears after communication is re-established with applicable system component (device).
125	Service Urgent	Control Hardware Problem	<p>There is a hardware problem on a system component control. There is a control hardware problem.</p> <ul style="list-style-type: none"> <li>• In system using Lennox Smart Zoning, the system will remain in non-zone mode (all dampers open) for five minutes after priority condition no longer exist.</li> <li>• In systems using a Equipment Interface Module, remove jumper if present on indoor unit between <b>R</b> and <b>W2</b>.</li> <li>• In systems using a PureAir S, the pure air control board jumper selector is missing.</li> </ul> <p>If none of the above tips are applicable, then replace the control if the problem prevents operation and is persistent.</p>	Automatically clears five minutes after the issue no longer exists.
126	Service Urgent	Control Internal Communication Prob	<p>There is an internal hardware problem on the system component control. In addition, if you have zoning the alert code is triggered when your zone temperature is deviating away from set point persistently.</p> <ul style="list-style-type: none"> <li>• Typically the system component control will reset itself.</li> <li>• Replace the system component (device) control if the problem prevents operation and is persistent.</li> </ul>	Automatically clears 300 seconds after the issue no longer exists.
132	Service Urgent	Device Control Software Fault	<p>System component control software is corrupted.</p> <ul style="list-style-type: none"> <li>• Recycle power.</li> <li>• If failure re-occurs, replace the system component control.</li> </ul>	Manual system power reset is required to recover from this alert code.
500	Service Soon	PA Differential Pressure Sensor Fault	<ul style="list-style-type: none"> <li>• Pressure sensor reports a fault for more than 5 minutes, or does not respond for more than 5 minutes.</li> <li>• Device will not perform any pressure reading calculations until fault is recovered. Remaining filter life display will indicate “-“ while fault exists.</li> </ul>	Automatically clears 30 seconds after fault is recovered.
501	Service Soon	PA UV Sensor Fault	<ul style="list-style-type: none"> <li>• Ultra-violet (UV) sensor reports a fault for more than 5 minutes or UV sensor does not respond for more than 5 minutes.</li> <li>• Device will not perform any UV lamp life remaining calculations until fault has recovered. Life remaining display shall indicate “-“ while fault exists.</li> </ul>	Automatically clears 30 seconds after fault is recovered.
502	Service Soon	PA UV Lamp Off	The light is determined to be off when the last three last light intensities measurements are below the set threshold.	Light is determined on after 1 set of five samples are above the set threshold.
504	Service Soon	PA Filter Life At 0%	Filter life remaining determined to be 0%.	None

**Table 6. Alert Codes and Troubleshooting**

GF= Gas Furnace, AH=Air Handler, ID=Indoor unit (GF or AH), HP=Heat Pump, AC=Air Conditioner, OD=Outdoor Unit (AC or HP), PA=Pure Air S, ZA=Zone system and TS=Thermostat

Alert Code	Priority Condition	Actual Displayed Alert Text Under dealer control center > Notifications	Component or System Operational State and Troubleshooting Tip	How to clear alert code
505	Service Soon	PA Model Selection Changed	Model Selection jumper has changed positions.	Jumper repositioned back to original jumper position or system rebooted.
506	Service Soon	PA Lamp At 0% life	Ultra violet lamp life is at 0%.	None
507	Service Soon	PA Filter Calibration Failure	<ul style="list-style-type: none"> <li>• Filter calibration determined failed due to all test cfm static pressures reading &lt;= 7 Pa.</li> <li>• Send alert code immediately.</li> <li>• No filter tests or life calculation occur while this alert code is active.</li> </ul>	Clear alert code upon initiation of another filter calibration.
--	Service Soon	--	Possible loose or mis-wired connections or two zone sensors are assigned the same zone number. Two dashes will be displayed on the S30 thermostat for indoor temperature and/or zone sensor. The system will go into central mode. Individual zone functions is disabled. Anytime the zone sensor loses communication with the damper control module, the entire system will go into central mode. If two sensors are assigned the same zone number, this could result in the double dashes to appear as well.	If two zone sensors are assigned the same zone number, this could cause the double dashes to appear. If loose or mis-wired connection was confirmed, correct the issue and run the re-configuration procedure.

## Operation

1. Check to ensure that access panel is securely in place.
2. Lamp should remain illuminated continuously except during service and maintenance.
3. For optimal odor control, air handler blower should remain on CONTINUOUSLY (thermostat fan setting in ON position, rather than AUTO).

**NOTE:** If air handler does not provide a continuous low blower speed option, an additional blower relay should be installed. Use Lennox part number 45H03. Contact the Lennox Application Department at 1-800-453-6669 for wiring information.

**NOTE:** Continuous fan operation may result in higher humidity. If humidity levels are uncomfortably high, fan setting should be switched to AUTO during cooling operation.

## Filter, UVA Lampholder / PCO Cartridge and UVA Lamp Replacement

### IMPORTANT

Hg -- UVA Lamp contain mercury.  
 Manage in accord with disposal laws.  
 Refer to [www.lamprecycle.org](http://www.lamprecycle.org) or call 1-800-9LENNOX.

The Healthy Climate® Carbon Clean 16® Filter, UVA Lampholder / PCO cartridge and UVA lamp require annual replacement. More frequent filter replacement may be required in applications with heavier dust or dirt loads or if you notice a reduction in odor-removal efficiency. An annual maintenance kit is available.

## Annual Maintenance Kits

The annual maintenance kits include the following:

- Healthy Climate® Carbon Clean 16® Filter (1)
- PCO cartridge (1)
- UVA lamp (1)

Order using the following kit catalog numbers:

**Table 7. Maintenance Kits**

Part Description	Catalog Numbers		
	PCO3S-14-16-02	PCO3S-16-16-02	PCO3S-20-16-02
Annual Maintenance Kit	Y6616	Y6612	Y6608

## Replacement Parts

Replacement parts are available through Lennox, see "Figure 1. Parts Identification" on page 3 for parts arrangement. Part description and catalog numbers are as follows:

**Table 8. Repair Parts**

Part Description	Catalog Numbers		
	PCO3S-14-16-02	PCO3S-16-16-02	PCO3S-20-16-02
HC Carbon Clean 16 Filter	Y6606	Y6605	Y6604
UVA Lamp	X8794		
PCO cartridge insert (Purifier)	Y6621	Y6607	
Lampholder Assembly	Y6622		
Power Cord (120VAC)	49M48		
Power Cord (230VAC)	91X44		
Electrical Socket	75X77		
Ballast	32G20		
Probe Repair Kit	16X01	16X02	16X01
Sensor Repair Kit	27P27		
Surge Protector	X8928		

## REMOVING AND INSTALLING UVA LAMP, LAMPHOLDER AND AIR FILTER

---

### **IMPORTANT**

If the system has been operated for a period of time without the UVA lamp being illuminated, an odor may occur when lamp is illuminated. This odor is considered typical and should dissipate within 12 hours of full operation. If the odor does not subside after 48 hours of operation, instruct the homeowner to unplug the unit and contact a Lennox dealer.

### **CAUTION**

Personal Burn Hazard.

UVA lamp is very hot when illuminated.

Allow lamp to cool for 10 minutes before removing lamp from socket.

Injury may result from contact with hot UVA lamp.

1. Remove power cord from 120VAC or 230VAC receptacle.
2. Remove power cord from unit.
3. Remove access panel.
4. Remove Healthy Climate® Carbon Clean 16® Filter.

5. Rotate out the hinged control panel.
6. Disconnect UVA lamp electrical connector from ballast.
7. Remove both fasteners securing the UVA Lampholder / PCO cartridge from the chassis.
8. Slide out the UVA Lampholder / PCO cartridge from the chassis.
9. Remove both brass finger nuts that secure the UVA lamp elector connector to the UVA Lampholder / PCO cartridge.
10. Slide out UVA lamp from UVA Lampholder / PCO cartridge insert.
11. Push the red button on UVA lamp electrical connector and gently slide off connector from UVA lamp (do not dispose of UVA lamp electrical connector).
12. Properly dispose of UVA lamp and air filter.
13. Reinstall in reverse order starting.

### **PROPER CLEAN-UP OF BROKEN UVA LAMP**

---

If UVA lamp is broken, it must be disposed of properly.

- Wear protective gloves, eye wear and mask.
- Sweep broken glass and debris into a plastic bag and seal before disposal in accordance with instructions provided by local waste management office.
- Do not use a vacuum cleaner. Do not incinerate.

# Troubleshooting Flow Chart

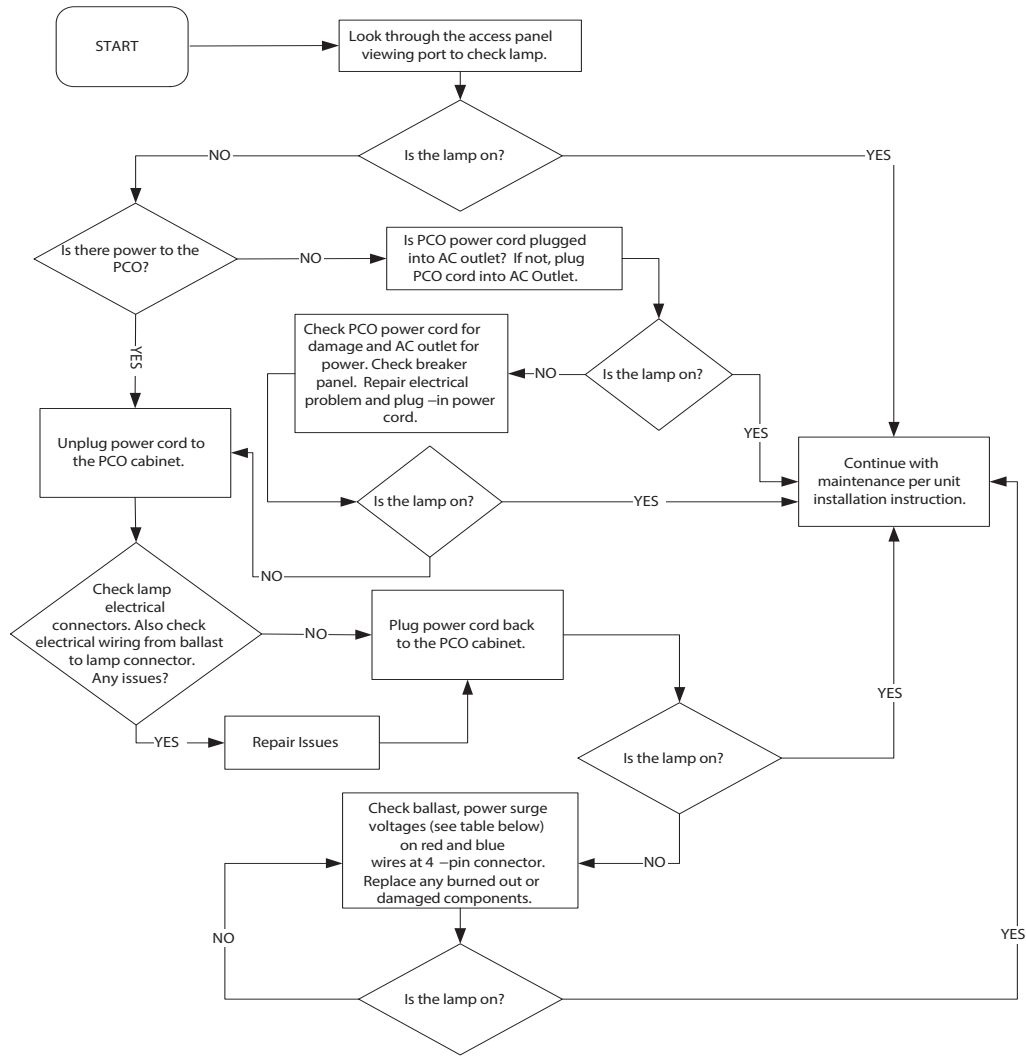

	INPUT/OUTPUT	WIRE/TERM COLOR	NORMAL READING (VAC)	SERVICE ACTION (See "Figure 15. PCO Wiring Schematic" on page 9.)
SPM	INPUT	BLACK	$\geq 105$	Replace input power connection or socket if less than 105 VAC
		WHITE	$\leq 2$	Replace SPM if greater than 2 VAC.
	OUTPUT	BLACK	$\geq 105$	Replace SPM if less than 105 VAC.
		WHITE	$\leq 2$	Replace SPM if greater than 2 VAC.
BALLAST	OUTPUT	RED	$\geq 60$	Replace ballast if less than 60VAC.
		RED	$\geq 60$	
		BLUE	$\geq 200$	Replace ballast if less than 200VAC.
		BLUE	$\geq 200$	

Figure 18. Troubleshooting Flowchart

