

# UNIT INFORMATION

100128

**LGM SERIES**  
7.5 to 12.5 ton  
38.1 to 70.3 kW

## Service Literature

### LGM092 through 150 With R-454B

The LGM092, 102, 120 and 150 units are configured to order units (CTO) with a wide selection of factory-installed options. Units are available in 130,000, 180,000 or 240,000 Btuh (38.1 kW, 52.7 kW, or 70.3 kW) heating inputs. Gas heat sections are designed with aluminized steel tube heat exchangers with stainless steel as an option.

Cooling capacities range from 7.5 to 12.5 tons. One circuit uses a high efficiency variable speed scroll compressor and the second circuit uses a fixed speed scroll compressor. Units also offer mechanical cooling down to 0 °F.

Units are also designed for R-454B refrigerant. Service equipment must be rated for R-454B.

All units are equipped with direct drive blowers. The blower will operate at lower speeds when demand is low and increase to higher speeds when demand is high. Variable speed VAV system is available as an option which enables supply duct static measurement to control blower CFM and discharge air temperature to control cooling stages.

All LGM units are designed to accept any of several different energy management thermostat control systems with minimum field wiring. Factory- or field-provided control options connect to the unit through Smartwire connectors.

When “plugged in” the controls become an integral part of the unit wiring.

The CORE Control System is designed to accelerate equipment install and service. Standard with all Model L™ rooftop units, the control system integrates key technologies that lower installation costs, drive system efficiency, and protect your investments. The CORE Unit Controller is a microprocessor-based controller that provides flexible control of all unit functions.

Information contained in this manual is intended for use by qualified service technicians only. All specifications are subject to change. Procedures outlined in this manual are presented as a recommendation only and do not supersede or replace local or state codes.

If the unit must be lifted for service, rig unit by attaching four cables to the holes located in the unit base rail (two holes at each corner). Refer to the installation instructions for the proper rigging technique.

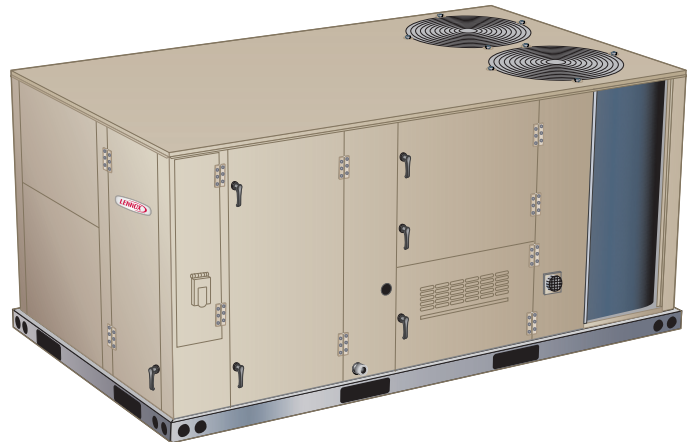

False ceilings or drop ceiling may be used as a return air plenum only if the unit being installed has a Refrigerant Detection System installed.

All maintenance staff and others working in the local area shall be instructed on the nature of work being carried out with work in confined spaces being avoided.

Ensure that the area is in the open or that it is adequately ventilated before breaking into the system or conducting any hot work. A degree of ventilation shall continue during the period that the work is carried out. The ventilation should safely disperse any released refrigerant and preferably expel it externally into the atmosphere.

#### Table of Contents

Options / Accessories . . . . .	Page 4
Specifications . . . . .	Page 7
Gas Heat Specifications / High Altitude . . . . .	Page 8
Blower Data . . . . .	Page 9
Electrical Data . . . . .	Page 12
I-Unit Components . . . . .	Page 15
II-Placement and Installation . . . . .	Page 35
III-Charging . . . . .	Page 35
IV-Start Up - Operation . . . . .	Page 45
V-System Service Checks . . . . .	Page 47
VI-Maintenance . . . . .	Page 49
VII-Accessories . . . . .	Page 52
VIII- Direct Drive Inverter . . . . .	Page 61
IX-Wiring and Operation Sequence . . . . .	Page 62
X-Decommissioning . . . . .	Page 71

## **⚠ WARNING**

To prevent serious injury or death:

- 1- Lock-out/tag-out before performing maintenance.
- 2- If system power is required (e.g., smoke detector maintenance), disable power to blower, remove fan belt where applicable, and ensure all controllers and thermostats are set to the "OFF" position before performing maintenance.
- 3- Always keep hands, hair, clothing, jewelry, tools, etc., away from moving parts.

## **⚠ WARNING**

Only Manufacturer approved auxiliary devices are permitted to be installed in this unit.

## **⚠ CAUTION**

Any service personnel installing, decommissioning, or performing maintenance on the unit must be properly trained with A2L refrigerants.

## **⚠ WARNING**



Electric shock hazard. Can cause injury or death. Before attempting to perform any service or maintenance, turn the electrical power to unit OFF at disconnect switch(es). Unit may have multiple power supplies.

## **⚠ WARNING**

Improper installation, adjustment, alteration, service or maintenance can cause property damage, personal injury or loss of life. Installation and service must be performed by a licensed professional HVAC installer or equivalent, service agency, or the gas supplier.

## **⚠ CAUTION**

As with any mechanical equipment, contact with sharp sheet metal edges can result in personal injury. Take care while handling this equipment and wear gloves and protective clothing.

## **⚠ WARNING**

- This appliance must be installed in accordance with local and national wiring regulations.
- If the appliance is not fitted with an option for full disconnection from power, a means of disconnection must be incorporated in the fixed wiring in accordance with national and local wiring regulations.

## **⚠ CAUTION**

The appliance is not to be used by persons (including children) with reduced physical, sensory or mental capabilities, or lack of experience and knowledge, unless they have been given supervision or instruction

## **⚠ CAUTION**

Children should be supervised not to play with the appliance.

## **⚠ CAUTION**

Servicing shall be performed only as recommended by the manufacturer.

## **⚠ CAUTION**

Leak Detection System installed. Unit must be powered except for service.

## **⚠ WARNING**

Ducts connected to an appliance shall not contain a potential ignition source.

## **⚠ IMPORTANT**

Pipe work, including piping material, pipe routing, and installation shall include protection from physical damage in operation and service, and be in compliance with national and local codes and standards, such as ASHRAE 15, ASHRAE 15.2, IAPMO Uniform Mechanical Code, ICC International Mechanical Code, or CSA B52. All field joints shall be accessible for inspection prior to being covered or enclosed.

## **⚠ IMPORTANT**

Refrigerant sensors for refrigerant detection systems shall only be replaced with sensors specified by the appliance manufacture.

## **⚠ CAUTION**

This unit is equipped with electrically powered safety measures. To be effective, the unit must be electrically powered at all times after installation, other than when servicing.

## **⚠ WARNING**

Do not use means to accelerate the defrosting process or to clean, other than those recommended by the manufacturer.

The appliance shall be stored in a room without continuously operating ignition sources (for example: open flames, an operating gas appliance, or an operating electric heater).

Do not pierce or burn.

Be aware that refrigerants may not contain an odor.

## ⚠ WARNING

If this appliance is conditioning a space with an area smaller than TA min or stored in a space with an area smaller than A min as defined by this instruction, then that space must be without continuously operating open flames (e.g. an operating gas appliance) or other potential ignition sources (e.g. an operating electric heater or similar hot surface). A flame-producing device may be installed in the same space if the device is provided with an effective flame arrest system.

## ⚠ WARNING

Auxiliary devices which may be potential ignition sources shall not be installed in the duct work. Examples of potential ignition sources are hot surfaces with a temperature exceeding 700°C and electric switching components.

**Minimum Airflow<sup>1</sup>**

Unit	Q <sub>min</sub> (CFM)	Q <sub>min</sub> (m <sup>3</sup> h)
LGM092	193	328
LGM102	193	328
LGM120	217	369
LGM150	214	364
LGM092 W/ Humidrol	215	365
LGM102 W/ Humidrol	215	365
LGM120 W/ Humidrol	215	365
LGM150 W/ Humidrol	215	365

<sup>1</sup> **NOTE** - The minimum airflow is the lowest CFM allowed during venting operation (leak mitigation).

**Minimum Room Area of Conditioned Space**

Unit	TA <sub>min</sub> (ft <sup>2</sup> )	TA <sub>min</sub> (m <sup>2</sup> )
LGM092	107	9.9
LGM102	107	9.9
LGM120	121	11.2
LGM150	119	11.0
LGM092 W/ Humidrol	120	11.1
LGM102 W/ Humidrol	120	11.1
LGM120 W/ Humidrol	120	11.1
LGM150 W/ Humidrol	120	11.1

<sup>2</sup> **NOTE** - The minimum room area of conditioned space is the smallest area the unit can service.

**Altitude Adjustment Factor<sup>3</sup>**

	0	200	400	600	800	1000	1200	1400	1600
<b>Halt</b>	0	200	400	600	800	1000	1200	1400	1600
<b>AF</b>	0	200	400	600	800	1000	1200	1400	1600
<b>Halt</b>	1	1	1	1	1.02	1.05	1.04	1.1	1.12
<b>AF</b>	1600	1800	2000	2200	2400	2600	2800	3000	3200
	1.12	1.15	1.18	1.21	1.25	1.28	1.32	1.36	1.4

<sup>3</sup> **NOTE** - Use the Altitude Adjustment Factor to adjust the values in the tables above to different altitudes. Find the relevant altitude above sea level in the two "Halt" rows and then multiply the value needed from the tables above by the altitude factor number. Example: For the minimum airflow in CFM for an LGM092 at 1000 ft. above sea level, multiply 193 by 1.05 to get 202.65 CFM as the new Q<sub>min</sub>.

**Refrigerant Charge R-454B**

Unit	M <sub>c</sub> (lbs)	M <sub>c</sub> (kg)
LGM092 STG 1	7.3	3.31
LGM092 STG 2	5.1	2.31
LGM102 STG 1	7.3	3.31
LGM102 STG 2	5.1	2.31
LGM120 STG 1	8.22	3.73
LGM120 STG 2	4.59	2.08
LGM150 STG 1	8.1	3.67
LGM150 STG 2	5.78	2.62
LGM092 W/ Humidrol STG 1	8.125	3.69
LGM092 W/ Humidrol STG 2	4.75	2.15
LGM102 W/ Humidrol STG 1	8.125	3.69
LGM102 W/ Humidrol STG 2	4.75	2.15
LGM120 W/ Humidrol STG 1	8.125	3.69
LGM120 W/ Humidrol STG 2	4.75	2.15
LGM150 W/ Humidrol STG 1	8.125	3.69
LGM150 W/ Humidrol STG 2	5.875	2.66

## OPTIONS / ACCESSORIES

Item Description	Order Number	Size				
		092	102	120	150	
<b>COOLING SYSTEM</b>						
Condensate Drain Trap	PVC	<b>22H54</b>	OX	OX	OX	OX
	Copper	<b>76W27</b>	X	X	X	X
Corrosion Protection	Factory		O	O	O	O
Drain Pan Overflow Switch		<b>21Z07</b>	OX	OX	OX	OX
<b>HEATING SYSTEM</b>						
Bottom Gas Piping Kit		<b>54W95</b>	X	X	X	X
Combustion Air Intake Extensions		<b>19W51</b>	X	X	X	X
Gas Heat Input	130,000 Btuh	Factory	O	O	O	O
	180,000 Btuh	Factory	O	O	O	O
	240,000 Btuh	Factory	O	O	O	O
Low Temperature Vestibule Heater	208/230V-3ph	<b>22A51</b>	X	X	X	X
	460V-3ph	<b>22A55</b>	X	X	X	X
	575V-3ph	<b>13X65</b>	X	X	X	X
LPG/Propane Conversion Kits	Standard Heat	<b>14N22</b>	X	X	X	X
	Medium Heat	<b>14N23</b>	X	X	X	X
	High Heat	<b>14N25</b>	X	X	X	X
Stainless Steel Heat Exchanger	Factory		O	O	O	O
Vertical Vent Extension Kit		<b>42W16</b>	X	X	X	X
<b>BLOWER - SUPPLY AIR</b>						
Blower	DirectPlus™ Direct Drive ECM Blower System with SZVAV	Factory	O	O	O	O
	DirectPlus™ Direct Drive ECM Blower System with VAV	Factory	O	O	O	O
<b>CABINET</b>						
Combination Coil/Hail Guards		<b>24C85</b>	OX	OX	OX	OX
Horizontal Discharge Kit		<b>51W25</b>	X	X	X	X
Return Air Adaptor Plate (for LC/LG and TC/TG/TH unit replacement)		<b>54W96</b>	OX	OX	OX	OX
<b>CONTROLS</b>						
Commercial Controls	LonTalk® Module - For Lennox® CORE Control System	<b>54W27</b>	OX	OX	OX	OX
	Novar® LSE	Factory	O	O	O	O
Dirty Filter Switch		<b>53W67</b>	OX	OX	OX	OX
Fresh Air Tempering		<b>21Z08</b>	OX	OX	OX	OX
Smoke Detector - Supply or Return (Power board and one sensor)		<b>31A68</b>	OX	OX	OX	OX
Smoke Detector - Supply and Return (Power board and two sensors)		<b>31A69</b>	OX	OX	OX	OX

NOTE - Catalog numbers shown are for ordering optional accessories if a field installed option is available.

OX - Configure To Order (Factory Installed) or Field Installed

O = Configure To Order (Factory Installed)

X = Field Installed

## OPTIONS / ACCESSORIES

Item Description	Order Number	Size				
		092	102	120	150	
<b>INDOOR AIR QUALITY</b>						
<b>Air Filters</b>						
Healthy Climate® High Efficiency Air Filters 20 x 25 x 2 in.	MERV 8 (Order 4)	<b>50W61</b>	OX	OX	OX	OX
	MERV 13 (Order 4)	<b>52W41</b>	OX	OX	OX	OX
	MERV 16 (Order 4)	<b>21U51</b>	OX	OX	OX	OX
Replacement Media Filter With Metal Mesh Frame 20 x 25 x 2 in. (includes non-pleated filter media)	(Order 4)	<b>Y3063</b>	X	X	X	X
<b>Indoor Air Quality (CO<sub>2</sub>) Sensors</b>						
Sensor - Wall-mount, off-white plastic cover with LCD display		<b>24C58</b>	X	X	X	X
Sensor - Wall-mount, off-white plastic cover, no display		<b>23V86</b>	X	X	X	X
Sensor - Black plastic case, LCD display, rated for plenum mounting		<b>87N52</b>	X	X	X	X
Sensor - Black plastic case, no display, rated for plenum mounting		<b>23V87</b>	X	X	X	X
CO <sub>2</sub> Sensor Duct Mounting Kit - for downflow applications		<b>23Y47</b>	X	X	X	X
Aspiration Box - for duct mounting non-plenum rated CO <sub>2</sub> sensors ( <b>24C58</b> )		<b>90N43</b>	X	X	X	X
<b>Needlepoint Bipolar Ionization (NPBI)</b>						
Needlepoint Bipolar Ionization (NPBI) Kit		<b>21U36</b>	X	X	X	X
<b>UVC Germicidal Lamps</b>						
<sup>1</sup> Healthy Climate® UVC Light Kit (110//230V-1ph)		<b>21A93</b>	X	X	X	X
<b>ELECTRICAL</b>						
Voltage 60 Hz	208/230V - 3 phase	Factory	O	O	O	O
	460V - 3 phase	Factory	O	O	O	O
	575V - 3 phase	Factory	O	O	O	O
HACR Circuit Breakers		Factory	O	O	O	O
<sup>2</sup> Short-Circuit Current Rating (SCCR) of 100kA (includes Phase/Voltage Detection)		Factory	O	O	O	O
Disconnect Switch	80 amp	<b>54W56</b>	OX	OX	OX	OX
GFI Service Outlets	15 amp non-powered, field-wired (208/230V, 460V only)	<b>74M70</b>	OX	OX	OX	OX
	<sup>3</sup> 20 amp non-powered, field-wired (208/230V, 460V, 575V)	<b>67E01</b>	X	X	X	X
	<sup>3</sup> 20 amp non-powered, field-wired (575V only)	Factory	O	O	O	O
Weatherproof Cover for GFI		<b>10C89</b>	X	X	X	X
<sup>1</sup> For 460V and 575V units, field installed lamps utilize jumpers to the outdoor fan transformer for voltage needed. See the installation Instructions.						
<sup>2</sup> Disconnect Switch is furnished and factory installed with High SCCR option.						
<sup>3</sup> Canada requires a minimum 20 amp circuit. Select 20 amp, non-powered, field wired GFI.						
NOTE - Catalog numbers shown are for ordering optional accessories if a field installed option is available.						
OX - Configure To Order (Factory Installed) or Field Installed						
O = Configure To Order (Factory Installed)						
X = Field Installed						

## OPTIONS / ACCESSORIES

Item Description	Order Number	Size				
		092	102	120	150	
<b>ECONOMIZER</b>						
<b>High Performance Economizer (Approved for California Title 24 Building Standards / AMCA Class 1A Certified)</b>						
High Performance Economizer (Downflow or Horizontal)	20U80	OX	OX	OX	OX	
Includes Economizer Dampers with Outdoor Air Hood and Barometric Relief Dampers with Exhaust Hood						
Downflow Applications - Use furnished Outdoor Air Hood and Barometric Relief Dampers with Exhaust Hood						
Horizontal Applications - Use furnished Outdoor Air Hood and Barometric Relief Dampers with Exhaust Hood - Order Horizontal Discharge Kit separately						
Horizontal Applications (reduced height) - Order Horizontal Low Profile Barometric Relief Dampers with Exhaust Hood and Horizontal Discharge Kit ( <b>51W25</b> ) separately						
<b>Horizontal Low Profile Barometric Relief Dampers</b>						
Horizontal Low Profile Barometric Relief Dampers With Exhaust Hood	53K04	X	X	X	X	
<b>Economizer Controls</b>						
Differential Enthalpy (Not for Title 24)	Order 2 21Z09	OX	OX	OX	OX	
Sensible Control	Sensor is Furnished Factory	O	O	O	O	
Single Enthalpy (Not for Title 24)	21Z09	OX	OX	OX	OX	
Global Control	Sensor Field Provided Factory	O	O	O	O	
Building Pressure Control	13J77	X	X	X	X	
Outdoor Air CFM Control	13J76	X	X	X	X	
<b>OUTDOOR AIR</b>						
<b>Outdoor Air Dampers</b>						
Motorized Dampers (Hood furnished)	14G28	OX	OX	OX	OX	
Manual Dampers (Hood furnished)	14G29	OX	OX	OX	OX	
<b>POWER EXHAUST</b>						
Standard Static	208/230V-3ph	53W44	OX	OX	OX	OX
	460V-3ph	53W45	OX	OX	OX	OX
	575V-3ph	53W46	OX	OX	OX	OX
<b>HUMIDITROL®+ HOT GAS REHEAT OPTION (SZVAV MODELS ONLY)</b>						
Humiditrol+ Dehumidification Option	Factory	O	O	O	O	
<b>ROOF CURBS</b>						
<b>Hybrid Roof Curbs, Downflow</b>						
8 in. height	11F54	X	X	X	X	
14 in. height	11F55	X	X	X	X	
18 in. height	11F56	X	X	X	X	
24 in. height	11F57	X	X	X	X	
<b>Adjustable Pitch Curb, Downflow</b>						
14 in. height	54W50	X	X	X	X	
<b>CEILING DIFFUSERS</b>						
Step-Down - Order one	RTD11-95S	13K61	X			
	RTD11-135S	13K62		X	X	
	RTD11-185S	13K63			X	
Flush - Order one	FD11-95S	13K56	X			
	FD11-135S	13K57		X	X	
	FD11-185S	13K58			X	
Transitions (Supply and Return) - Order one	C1DIFF30B-1	12X65	X			
	C1DIFF31B-1	12X66		X	X	
	C1DIFF32B-1	12X67			X	

NOTE - Catalog numbers shown are for ordering optional accessories if a field installed option is available.

OX - Configure To Order (Factory Installed) or Field Installed

O = Configure To Order (Factory Installed)

X = Field Installed

SPECIFICATIONS				UNIT			
<b>Model</b>				<b>LGM092U5E</b>	<b>LGM102U5E</b>	<b>LGM120U5E</b>	<b>LGM150U5E</b>
<b>Blower Type</b>				DirectPlus™ ECM Direct Drive with SZVAV	DirectPlus™ ECM Direct Drive with SZVAV	DirectPlus™ ECM Direct Drive with SZVAV	DirectPlus™ ECM Direct Drive with SZVAV
<b>Model</b>				<b>LGM092U5P</b>	<b>LGM102U5P</b>	<b>LGM120U5P</b>	<b>LGM150U5P</b>
<b>Blower Type</b>				DirectPlus™ ECM Direct Drive with VAV	DirectPlus™ ECM Direct Drive with VAV	DirectPlus™ ECM Direct Drive with VAV	DirectPlus™ ECM Direct Drive with VAV
<b>Nominal Tonnage</b>				7.5 Ton	8.5 Ton	10 Ton	12.5 Ton
<b>Efficiency Type</b>				Ultra-High	Ultra-High	Ultra-High	Ultra-High
<b>Cooling Performance</b>	Gross Cooling Capacity (Btuh)			90,000	100,000	117,500	141,000
	<sup>1</sup> Net Cooling Capacity (Btuh)			88,000	97,000	114,000	136,000
	AHRI Rated Air Flow (cfm)			2800	3400	3600	4200
	<sup>1</sup> IEER (Btuh/Watt)			21.0	21.0	20.7	19.5
	<sup>1</sup> EER (Btuh/Watt)			12.5	12.5	12.0	10.8
	Total Unit Power - kW			7.0	7.8	9.5	12.6
<b>Sound Rating Number (minimum/maximum) dBA</b>				68 / 85	68 / 85	67 / 89	67 / 89
<b>Refrigerant Charge</b>	Refrigerant Type			R-454B	R-454B	R-454B	R-454B
	Without Reheat Option	Circuit 1		7 lbs. 5 oz.	7 lbs.. 5 oz.	8 lbs. 4 oz.	8 lbs. 2 oz.
		Circuit 2		5 lbs. 2 oz.	5 lbs. 2 oz.	4 lbs. 9 oz.	5 lbs. 12 oz.
	With Reheat Option	Circuit 1		8 lbs. 2 oz.	8 lbs. 2 oz.	8 lbs. 4 oz.	8 lbs. 2 oz.
		Circuit 2		4 lbs. 12 oz.	4 lbs. 12 oz.	4 lbs. 12 oz.	5 lbs. 14 oz.
<b>Gas Heating Options Available - See page 8</b>				Standard (2 Stage), Medium (2 Stage), High (2 Stage)			
<b>Compressor Type (number)</b>				Variable Capacity Scroll (1) Fixed Capacity Scroll (1)			
<b>Outdoor Coils</b>	Net face area - ft. <sup>2</sup>			26.7	26.7	26.7	26.7
	Rows			1	1	1	1
	Fins - in.			20	20	20	20
<b>Outdoor Coil Fans</b>	Motor HP (number and type)			1/3 (2 ECM)	1/3 (2 ECM)	1/3 (2 ECM)	1/3 (2 ECM)
	Rpm			300-900	300-1075	300-1075	300-1075
	Watts			65-650	65-750	65-750	65-750
	Diameter (Number) - in.			(2) 24	(2) 24	(2) 24	(2) 24
	Blades			3	3	3	3
	Total Air volume - cfm			6600	8800	8800	8800
	<b>Indoor Coil</b>	Net face area - ft. <sup>2</sup>			13.54	13.54	13.54
Tube diameter - in.			3/8	3/8	3/8	3/8	
Number of rows			4	4	4	4	
Fins - in.			14	14	14	14	
Condensate drain size (NPT) - in.			(1) 1				
Expansion device type			Balanced Port Thermostatic Expansion Valve,removable power head				
<b>Indoor Blower</b>	Nominal motor HP			3.75 (ECM)	3.75 (ECM)	3.75 (ECM)	3.75 (ECM)
	Blower wheel nominal diameter x width - in.			(1) 22 x 9	(1) 22 x 9	(1) 22 x 9	(1) 22 x 9
<b>Filters</b>	Type of filter			MERV 4, Disposable			
	Number and size - in.			(4) 20 x 25 x 2			
<b>Line voltage data (Volts-Phase-Hz)</b>				208/230-3-60, 460-3-60, 575-3-60			

NOTE - Net capacity includes evaporator blower motor heat deduction. Gross capacity does not include evaporator blower motor heat deduction.

<sup>1</sup> AHRI Certified to AHRI Standard 340/360; 95°F outdoor air temperature and 80°F db/67°F wb entering evaporator air; minimum external duct static pressure.

SPECIFICATIONS			GAS HEAT		
Heat Input Type			Standard	Medium	High
Number of Gas Heat Stages			2	2	2
Gas Heating Performance	Input - Btuh	First Stage	85,000	117,000	156,000
		Second Stage	130,000	180,000	240,000
	Output - Btuh	Second Stage	105,000	146,000	194,000
Temperature Rise Range - °F			15 - 45	30 - 60	40 - 70
Minimum Air Volume - cfm			2150	2250	2600
Thermal Efficiency			81%	81%	81%
Gas Supply Connections			3/4 in. NPT	3/4 in. NPT	3/4 in. NPT.
Recommended Gas Supply Pressure - Nat. / LPG			7 in. w.g. / 11 in. w.g.		
Gas Supply Pressure Range		Min./Max. (Natural)	4.7 - 10.5 in. w.g.		
		Min./Max. (LPG)	10.8 - 13.5 in. w.g.		

## HIGH ALTITUDE DERATE

Units may be installed at altitudes up to 2000 feet above sea level without any modification.

At altitudes above 2000 feet, units must be derated to match gas manifold pressures shown in table below.

At altitudes above 4500 feet unit must be derated 4% for each 1000 feet above sea level.

NOTE – This is the only permissible derate for these units.

Gas Heat Type	Altitude Feet	Gas Manifold Pressure in. w.g.		Input Rate - Btuh (Natural Gas or LPG/Propane)	
		Natural Gas	LPG/Propane Gas	First Stage	Second Stage
Standard	2001-4500	1.6 / 3.1	4.4 / 8.9	84,500	120,000
Medium	2001-4500	1.6 / 3.1	4.4 / 8.9	117,000	166,000
High	2001-4500	1.6 / 3.1	4.4 / 8.9	156,000	221,000

## BLOWER DATA

**BLOWER TABLE INCLUDES RESISTANCE FOR BASE UNIT ONLY (NO HEAT SECTION) WITH DRY INDOOR COIL AND AIR FILTERS IN PLACE.**

FOR ALL UNITS ADD:

- 1 – Wet indoor coil air resistance of selected unit.
  - 2 – Any factory installed options air resistance (heat section, Economizer, etc.)
  - 3 – Any field installed accessories air resistance (duct resistance, diffuser, etc.)
- See page 10 for wet coil and option/accessory air resistance data.

**Maximum Static Pressure With Gas Heat - 2.0 in. w.g.**

**Minimum Air Volume Required For Different Gas Heat Sizes:**

Standard - 2150 cfm; Medium - 2250 cfm; High - 2600 cfm

Total Air Volume cfm	Total Static Pressure - in. w.g.													
	0.2		0.4		0.6		0.8		1.0		1.2		1.4	
	RPM	Watts	RPM	Watts	RPM	Watts	RPM	Watts	RPM	Watts	RPM	Watts	RPM	Watts
1750	644	137	740	235	796	302	833	343	873	373	996	558	1065	664
2000	675	165	768	260	821	330	861	386	960	507	1026	629	1094	753
2250	711	195	803	290	856	375	901	497	991	564	1058	703	1128	840
2500	764	241	852	335	904	439	951	568	1025	641	1097	789	1170	934
2750	847	316	901	399	946	543	1004	674	1074	746	1146	895	1220	1041
3000	944	426	980	511	1021	671	1074	803	1136	874	1205	1021	1276	1167
3250	1022	544	1057	640	1099	810	1149	942	1207	1012	1272	1156	1338	1304
3500	1092	666	1131	770	1174	948	1225	1081	1281	1151	1342	1297	1402	1451
3750	1161	780	1202	892	1248	1079	1298	1217	1353	1291	1409	1445	1463	1609
4000	1230	888	1273	1010	1319	1212	1369	1362	1421	1441	1471	1608	1518	1784
4250	1299	1006	1342	1140	1388	1362	1436	1526	1483	1612	1528	1790	1571	1975
4500	1366	1142	1409	1289	1454	1532	1498	1708	1542	1798	1583	1984	1623	2172
4750	1432	1295	1474	1457	1516	1719	1558	1903	1598	1997	1637	2187	1674	2377
5000	1496	1471	1537	1645	1577	1921	1616	2110	1654	2205	1690	2396	1726	2586
5250	1560	1667	1598	1849	1636	2132	1673	2324	1709	2419	1744	2609	1779	2796
5500	1623	1878	1659	2064	1695	2349	1731	2539	1765	2634	---	---	---	---
5750	1686	2097	1720	2284	1755	2567	---	---	---	---	---	---	---	---
6000	1748	2316	1781	2502	---	---	---	---	---	---	---	---	---	---

Total Air Volume cfm	Total Static Pressure - in. w.g.											
	1.6		1.8		2.0		2.2		2.4		2.6	
	RPM	Watts	RPM	Watts	RPM	Watts	RPM	Watts	RPM	Watts	RPM	Watts
1750	1134	775	1203	896	1275	1025	1356	1149	1422	1287	1470	1439
2000	1162	878	1231	1007	1302	1139	1379	1268	1440	1411	1486	1570
2250	1198	975	1268	1111	1338	1250	1409	1388	1464	1542	1507	1711
2500	1243	1075	1313	1217	1380	1365	1442	1517	1491	1685	1533	1860
2750	1293	1186	1361	1336	1423	1494	1477	1661	1520	1839	1561	2016
3000	1346	1317	1410	1474	1466	1642	1514	1818	1554	2000	1594	2180
3250	1402	1460	1460	1627	1511	1803	1553	1986	1591	2172	1631	2352
3500	1459	1616	1509	1793	1555	1976	1594	2165	1631	2352	1671	2531
3750	1512	1785	1557	1970	1599	2159	1636	2350	1673	2536	1713	2714
4000	1562	1969	1604	2157	1643	2347	1680	2538	1717	2722	1756	2896
4250	1611	2163	1650	2352	1688	2541	1724	2729	1762	2908	---	---
4500	1661	2362	1698	2552	1734	2739	1770	2922	---	---	---	---
4750	1710	2567	1746	2754	---	---	---	---	---	---	---	---
5000	1761	2774	---	---	---	---	---	---	---	---	---	---

## BLOWER DATA

### POWER EXHAUST FAN PERFORMANCE

Return Air System Static Pressure	Air Volume Exhausted
in. w.g.	cfm
0	3175
0.05	2955
0.10	2685
0.15	2410
0.20	2165
0.25	1920
0.30	1420
0.35	1200

### FACTORY INSTALLED OPTIONS/FIELD INSTALLED ACCESSORY AIR RESISTANCE - in. w.g.

Air Volume cfm	Wet Indoor Coil		Gas Heat Exchanger			Economizer	Humiditrol® + Reheat Coil	Filters			Return Air Adaptor Plate
			Standard Heat	Medium Heat	High Heat			MERV 8	MERV 13	MERV 16	
	092, 102	120, 150									
1750	0.04	0.04	0.06	0.02	0.02	0.05	0.02	0.01	0.03	0.06	0.00
2000	0.05	0.05	0.07	0.05	0.06	0.06	0.02	0.01	0.03	0.08	0.00
2250	0.06	0.06	0.07	0.07	0.08	0.08	0.02	0.01	0.04	0.09	0.00
2500	0.07	0.07	0.09	0.10	0.11	0.11	0.03	0.01	0.05	0.10	0.00
2750	0.08	0.08	0.09	0.11	0.12	0.12	0.03	0.02	0.05	0.11	0.00
3000	0.10	0.09	0.11	0.12	0.13	0.13	0.03	0.02	0.06	0.12	0.02
3250	0.11	0.10	0.12	0.15	0.16	0.15	0.04	0.02	0.06	0.13	0.02
3500	0.12	0.11	0.12	0.16	0.17	0.15	0.04	0.03	0.07	0.15	0.04
3750	0.14	0.13	0.14	0.19	0.20	0.15	0.05	0.03	0.08	0.16	0.07
4000	0.15	0.14	0.14	0.21	0.22	0.19	0.05	0.04	0.08	0.17	0.09
4250	0.17	0.15	0.14	0.24	0.28	0.19	0.06	0.04	0.09	0.19	0.11
4500	0.19	0.17	0.15	0.26	0.32	0.22	0.07	0.04	0.09	0.20	0.12
4750	0.20	0.18	0.16	0.29	0.37	0.25	0.07	0.05	0.10	0.21	0.16
5000	0.22	0.20	0.16	0.34	0.43	0.29	0.08	0.06	0.10	0.23	0.18
5250	0.24	0.22	0.16	0.37	0.47	0.32	0.08	0.06	0.11	0.24	0.19
5500	0.25	0.23	0.18	0.44	0.54	0.34	0.09	0.07	0.12	0.25	0.22
5750	0.27	0.25	0.19	0.49	0.59	0.45	0.10	0.07	0.12	0.27	0.25
6000	0.29	0.27	0.20	0.54	0.64	0.52	0.10	0.08	0.13	0.28	0.27

## BLOWER DATA

### CEILING DIFFUSERS AIR RESISTANCE - in. w.g.

Size	RTD11 Step-Down Diffuser			FD11 Flush Diffuser	
	Air Volume cfm	2 Ends Open	1 Side, 2 Ends Open		All Ends & Sides Open
092	2400	0.21	0.18	0.15	0.14
	2600	0.24	0.21	0.18	0.17
	2800	0.27	0.24	0.21	0.20
	3000	0.32	0.29	0.25	0.25
	3200	0.41	0.37	0.32	0.31
	3400	0.50	0.45	0.39	0.37
	3600	0.61	0.54	0.48	0.44
	3800	0.73	0.63	0.57	0.51
102 & 120	3600	0.36	0.28	0.23	0.15
	3800	0.40	0.32	0.26	0.18
	4000	0.44	0.36	0.29	0.21
	4200	0.49	0.40	0.33	0.24
	4400	0.54	0.44	0.37	0.27
	4600	0.60	0.49	0.42	0.31
	4800	0.65	0.53	0.46	0.35
	5000	0.69	0.58	0.50	0.39
150	5200	0.75	0.62	0.54	0.43
	4200	0.22	0.19	0.16	0.10
	4400	0.28	0.24	0.20	0.12
	4600	0.34	0.29	0.24	0.15
	4800	0.40	0.34	0.29	0.19
	5000	0.46	0.39	0.34	0.23
	5200	0.52	0.44	0.39	0.27
	5400	0.58	0.49	0.43	0.31
	5600	0.64	0.54	0.47	0.35
5800	0.70	0.59	0.51	0.39	

### CEILING DIFFUSER AIR THROW DATA

Model	Air Volume cfm	<sup>1</sup> Effective Throw Range	
		RTD11 Step-Down	FD11 Flush
		ft.	ft.
092	2600	24 - 29	19 - 24
	2800	25 - 30	20 - 28
	3000	27 - 33	21 - 29
	3200	28 - 35	22 - 29
	3400	30 - 37	22 - 30
102, 120	3600	25 - 33	22 - 29
	3800	27 - 35	22 - 30
	4000	29 - 37	24 - 33
	4200	32 - 40	26 - 35
	4400	34 - 42	28 - 37
150	5600	39 - 49	28 - 37
	5800	42 - 51	29 - 38
	6000	44 - 54	40 - 50
	6200	45 - 55	42 - 51
	6400	46 - 55	43 - 52
	6600	47 - 56	45 - 56

<sup>1</sup> Throw is the horizontal or vertical distance an air stream travels on leaving the outlet or diffuser before the maximum velocity is reduced to 50 ft. per minute. Four sides open.

**ELECTRICAL DATA****7.5 TON**

Model		LGM092U5E/ LGM092U5P		
		208/230V-3ph	460V-3ph	575V-3ph
<sup>1</sup> Voltage - 60Hz				
Compressor 1 (Inverter)	Rated Load Amps	10.6	6.1	5.6
	Locked Rotor Amps	17	11.5	12
Compressor 2 (Non-Inverter)	Rated Load Amps	12.8	6	5.8
	Locked Rotor Amps	120.4	49.4	41
Outdoor Fan Motors (2)	Full Load Amps (2 ECM)	2.8	1.4	1.1
	Total	5.6	2.8	2.2
Power Exhaust (1) 0.33 HP	Full Load Amps	2.4	1.3	1
Service Outlet 115V GFI (amps)		15	15	20
Indoor Blower Motor	Horsepower	3.75	3.75	3.75
	Full Load Amps	8	4.2	3.6
<sup>2</sup> Maximum Overcurrent Protection (MOCP)	Unit Only	50	25	20
	With (1) 0.33 HP Power Exhaust	50	25	25
<sup>3</sup> Minimum Circuit Ampacity (MCA)	Unit Only	41	21	19
	With (1) 0.33 HP Power Exhaust	43	22	20

NOTE - All units have a minimum Short Circuit Current Rating (SCCR) of 5000 amps.

<sup>1</sup> Extremes of operating range are plus and minus 10% of line voltage.<sup>2</sup> HACR type breaker or fuse.<sup>3</sup> Refer to National or Canadian Electrical Code manual to determine wire, fuse and disconnect size requirements.**ELECTRICAL DATA****8.5 TON**

Model		LGM102U5E/ LGM102U5P		
		208/230V-3ph	460V-3ph	575V-3ph
<sup>1</sup> Voltage - 60Hz				
Compressor 1 (Inverter)	Rated Load Amps	10.6	6.1	5.6
	Locked Rotor Amps	17	11.5	12
Compressor 2 (Non-Inverter)	Rated Load Amps	12.8	6	5.8
	Locked Rotor Amps	120.4	49.4	41
Outdoor Fan Motors (2)	Full Load Amps (2 ECM)	2.8	1.4	1.1
	Total	5.6	2.8	2.2
Power Exhaust (1) 0.33 HP	Full Load Amps	2.4	1.3	1
Service Outlet 115V GFI (amps)		15	15	20
Indoor Blower Motor	Horsepower	3.75	3.75	3.75
	Full Load Amps	8	4.2	3.6
<sup>2</sup> Maximum Overcurrent Protection (MOCP)	Unit Only	50	25	20
	With (1) 0.33 HP Power Exhaust	50	25	25
<sup>3</sup> Minimum Circuit Ampacity (MCA)	Unit Only	41	21	19
	With (1) 0.33 HP Power Exhaust	43	22	20

NOTE - All units have a minimum Short Circuit Current Rating (SCCR) of 5000 amps.

<sup>1</sup> Extremes of operating range are plus and minus 10% of line voltage.<sup>2</sup> HACR type breaker or fuse.<sup>3</sup> Refer to National or Canadian Electrical Code manual to determine wire, fuse and disconnect size requirements.

**ELECTRICAL DATA****10 TON**

Model		LGM120U5E/ LGM120U5P		
		208/230V-3ph	460V-3ph	575V-3ph
<sup>1</sup> Voltage - 60Hz				
Compressor 1 (Inverter)	Rated Load Amps	13.7	7.5	6.7
	Locked Rotor Amps	21	12	12
Compressor 2 (Non-Inverter)	Rated Load Amps	16	7.1	6.4
	Locked Rotor Amps	156.4	69	47.8
Outdoor Fan Motors (2)	Full Load Amps (2 ECM)	2.8	1.4	1.1
	Total	5.6	2.8	2.2
Power Exhaust (1) 0.33 HP	Full Load Amps	2.4	1.3	1
Service Outlet 115V GFI (amps)		15	15	20
Indoor Blower Motor	Horsepower	3.75	3.75	3.75
	Full Load Amps	8	4.2	3.6
<sup>2</sup> Maximum Overcurrent Protection (MOCP)	Unit Only	60	30	25
	With (1) 0.33 HP Power Exhaust	60	30	25
<sup>3</sup> Minimum Circuit Ampacity (MCA)	Unit Only	48	24	21
	With (1) 0.33 HP Power Exhaust	50	25	22

NOTE - All units have a minimum Short Circuit Current Rating (SCCR) of 5000 amps.

<sup>1</sup> Extremes of operating range are plus and minus 10% of line voltage.<sup>2</sup> HACR type breaker or fuse.<sup>3</sup> Refer to National or Canadian Electrical Code manual to determine wire, fuse and disconnect size requirements.**ELECTRICAL DATA****12.5 TON**

Model		LGM150U5E/ LGM150U5P		
		208/230V-3ph	460V-3ph	575V-3ph
<sup>1</sup> Voltage - 60Hz				
Compressor 1	Rated Load Amps	13.7	7.5	6.7
	Locked Rotor Amps	21	12	12
Compressor 2	Rated Load Amps	22.4	9.1	7.2
	Locked Rotor Amps	166.2	74.6	54
Outdoor Fan Motors (2)	Full Load Amps (2 ECM)	2.8	1.4	1.1
	Total	5.6	2.8	2.2
Power Exhaust (1) 0.33 HP	Full Load Amps	2.4	1.3	1
Service Outlet 115V GFI (amps)		15	15	20
Indoor Blower Motor	Horsepower	3.75	3.75	3.75
	Full Load Amps	8	4.2	3.6
<sup>2</sup> Maximum Overcurrent Protection (MOCP)	Unit Only	70	30	25
	With (1) 0.33 HP Power Exhaust	80	35	25
<sup>3</sup> Minimum Circuit Ampacity (MCA)	Unit Only	56	26	22
	With (1) 0.33 HP Power Exhaust	58	28	23

NOTE - All units have a minimum Short Circuit Current Rating (SCCR) of 5000 amps.

<sup>1</sup> Extremes of operating range are plus and minus 10% of line voltage.<sup>2</sup> HACR type breaker or fuse.<sup>3</sup> Refer to National or Canadian Electrical Code manual to determine wire, fuse and disconnect size requirements.**FIELD WIRING NOTES**

- For use with copper wiring only
- Field wiring not furnished
- All wiring must conform to NEC or CEC and local electrical codes
- For specific wiring information, please refer to the installation instructions

## PARTS ARRANGENT

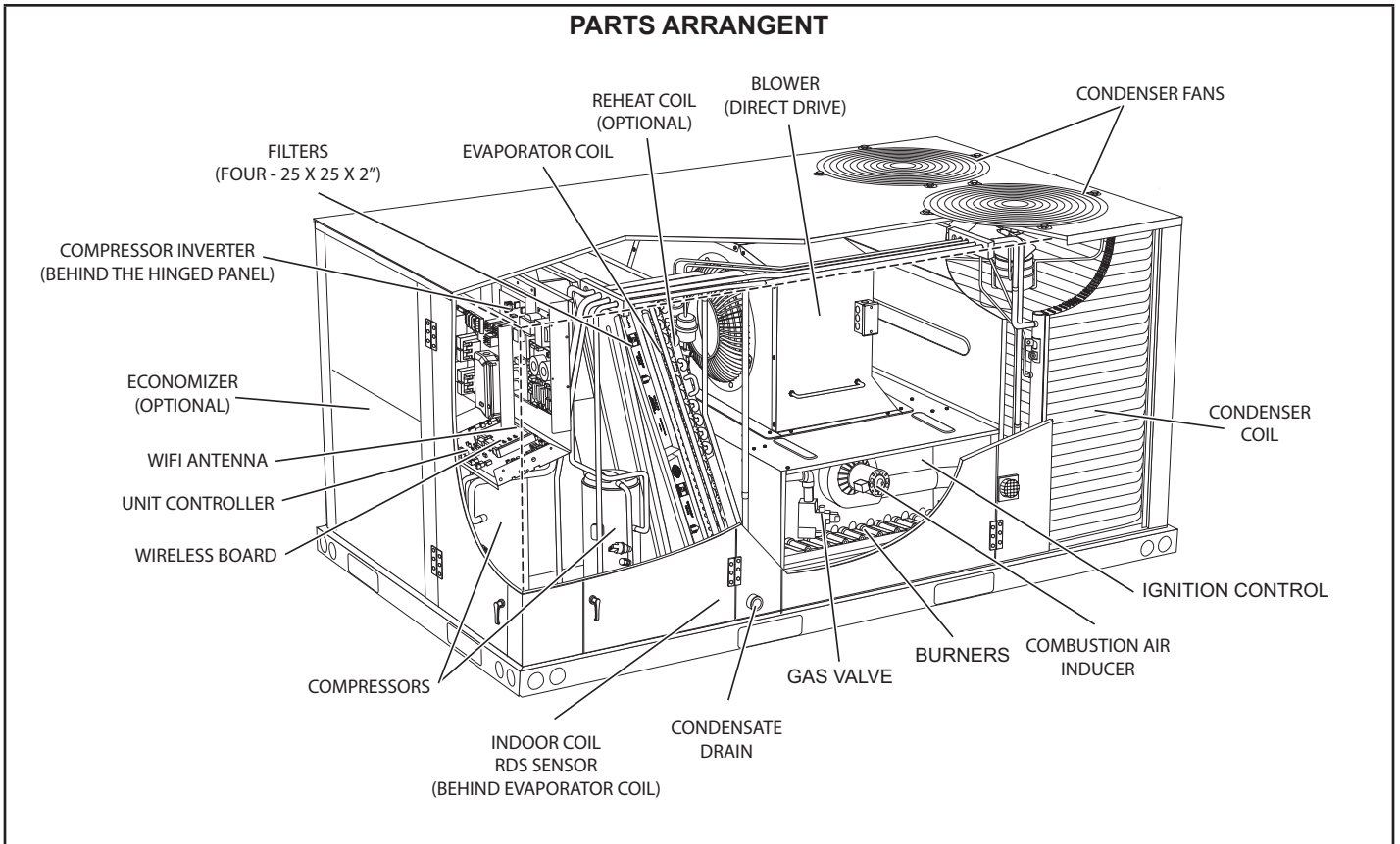

**FIGURE 1**

## CONTROL BOX PARTS ARRANGEMENT

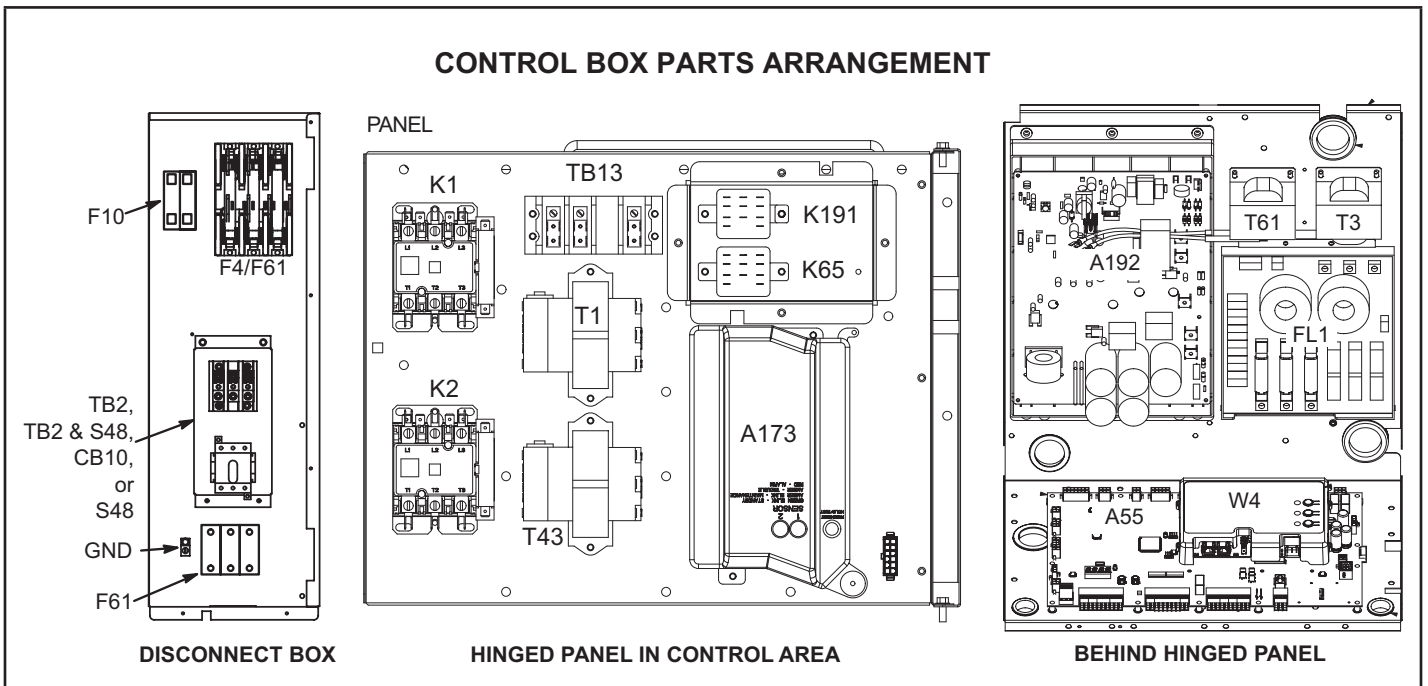

**FIGURE 2**

## I-UNIT COMPONENTS

### ELECTROSTATIC DISCHARGE (ESD)

#### Precautions and Procedures



All 7.5 through 12.5 ton units are configured to order units (CTO). The LGM unit components are shown in FIGURE 1. All units come standard with hinged unit panels. All L1, L2 and L3 wiring is color coded; L1 is red, L2 is yellow and L3 is blue.

#### A-Control Box Components

LGM control box components are shown in FIGURE 2. The control box is located in the upper portion of the compressor compartment.

##### 1-Disconnect Switch S48 (Optional)

All units may be equipped with an optional disconnect switch S48. Other factory or field installed optional circuit breakers may be used, such as CB10. S48 and CB10 are toggle switches, which can be used by the service technician to disconnect power to the unit.

##### 2-Control Transformer T1

All use a single line voltage to 24VAC transformer mounted in the control box. Transformer supplies power to control circuits in the unit. The transformer is rated at 92 VA and is protected by a 6 amp circuit breaker (CB8). The 208/230 (Y) voltage transformers use primary voltage taps as shown in FIGURE 3, while 460 (G) and 575 (J) voltage transformers use a single primary voltage tap.

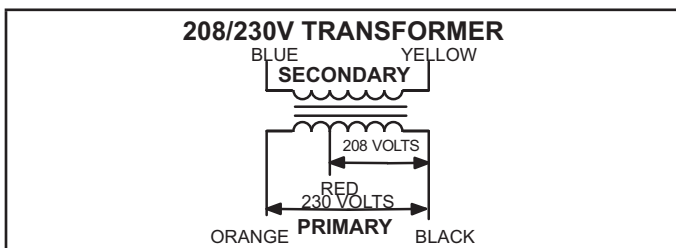

FIGURE 3

##### 3-Control Transformer T43 (Re-Heat Units)

T43 is a single line voltage to 24VAC transformer that supplies power to control circuits. See unit diagram. T43 is mounted in the control box, is rated at 70VA, and is protected by a 3.5 amp circuit breaker (CB31). The 208/230 (Y) voltage transformers use primary voltage taps as shown in figure 3, while 460 (G) and 575 (J) voltage transformers use a single primary voltage tap.

##### 4-C. A. I. Transformers T3 all 575V units

All LGM (J) voltage units use transformer T3. The auto voltage to 230VAC transformer is mounted in the control box behind the hinged panel to the right of the A192 Inverter for Compressor Circuit 1. See FIGURE 2. The transformer has an output rating of 0.5A. T3 transformer supplies 230

VAC power to combustion air blower motor (B6).

##### 5-Compressor Contactor K1, K2

All compressor contactors are three-pole, double-break contactors with 24VAC coils. K1 and K2 (both energized by A55) energize the A192 Inverter for compressors B1 and B2.

##### 6-Burner Controls A3

A3 controls gas heat section burner controls. Burner controls are factory set and are not adjustable. The control makes three attempts at ignition and then locks out the system if ignition is not obtained after the third trial. Reset after lockout requires only breaking and remaking thermostat demand. The control shuts off gas flow immediately in the event of a gas or power failure. Upon restoration of gas and power, the control will restart the ignition sequence and continue until flame is established or system locks out. For a more detailed description see the Gas Heat Components section.

##### 7-Power Exhaust Relay K65 (PED units)

Power exhaust relay K65 is a N.O. DPDT relay with a 24VAC coil. K65 is used in all LGM units equipped with the optional power exhaust dampers. K65 is energized by the unit controller A55, after the economizer dampers reach 50% open (adjustable in CORE Lite APP). When K65 closes, the exhaust fan B10 is energized.

##### 8-Unit Controller A55

The Unit Controller provides all unit control functions, unit status information, unit diagnostics, programmable parameters and USB verification and profile sharing. Refer to the Unit Controller guide provided with the unit. Thermostat wires are connected to J297 on the Unit Controller.

##### 9-Terminal Block TB13

TB13 terminal block distributes line voltage power to the line voltage items in the unit.

##### 10-Outdoor Fan Motor Fuse Block & Fuse F10

STD SCCR 240V, 300V and higher rated SCCR units have three line voltage fuses (F10) that provide overcurrent protection to all condenser fans. The fuses are rated at 30A in all 208/230V units but 10A in the 208/230V 240U and 300U models.

##### 11-Ultraviolet Germicidal Lamp (UVC) Transformer T49

UVC transformer T49 is used by units of all voltages except 208/230V which is equipped with a UVC. The auto voltage to 230VAC transformer is installed in the control box. The transformer has an output rating of 0.5 amps. T49 transformer supplies 230VAC power to the UVC lamp.

##### 12-Wireless Antenna

Wireless antenna is located above the return air compartment of the unit. FIGURE 4 shows location and FIGURE 5 shows cable routing. Please follow the CORE Lite Controller setup guide included in the unit.

## Antenna Location

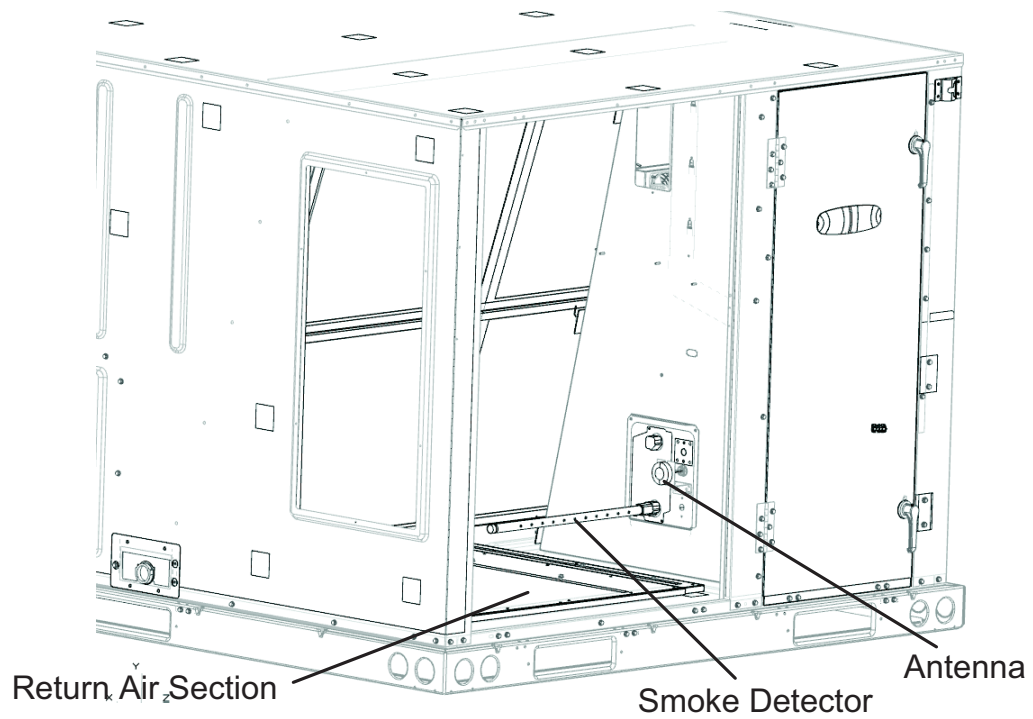

FIGURE 4

## Cable Routing

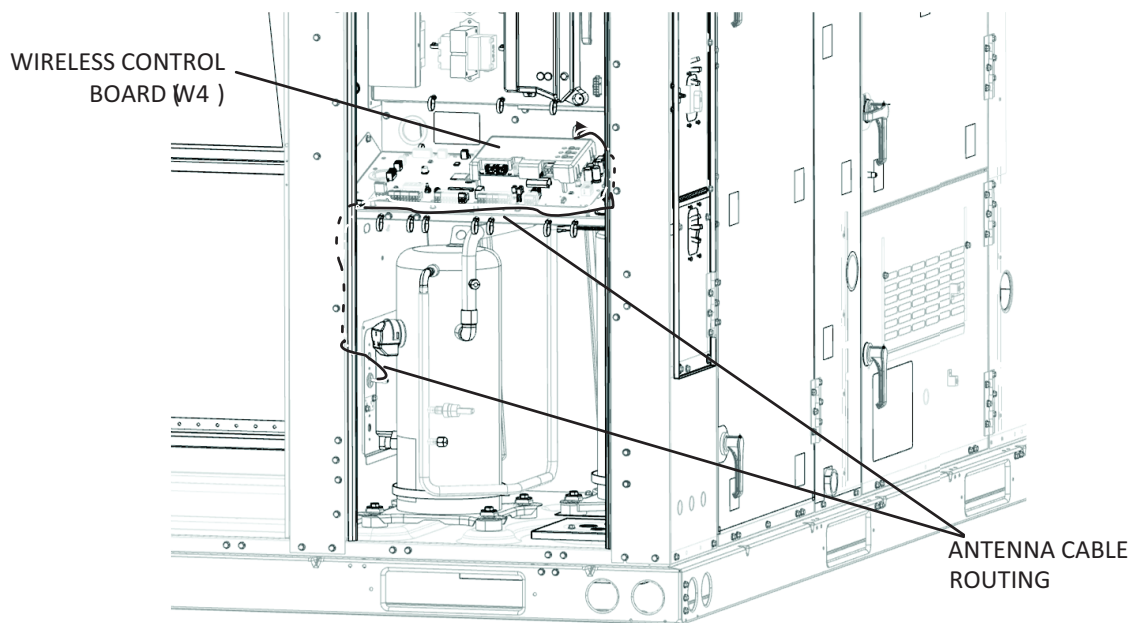

FIGURE 5

**Temperature Sensors** - The return air (RT16) and discharge air (RT6) duct probes and the outdoor air (RT17) are all two wire thermistors. The resistance vs. temperature table is shown below:

**TABLE 1**  
**Resistance vs. Temperature**

Temp. °F (°C)	Resistance +/-2%	Temperature °F (°C)	Resistance +/-2%	Temp. °F (°C)	Resistance +/-2%
-40 (-40)	335,671	40 (4.4)	26,106	90 (32.2)	7,332
-20 (-28.9)	164,959	50 (10)	19,904	100 (37.8)	5,826
0 (-17.8)	85,323	60 (15.6)	15,313	120 (48.9)	3,756
20 (-6.7)	46,218	70 (21.1)	11,884	130 (54.4)	3,047
30 (-1.1)	34,566	80 (26.7)	9,298		

**Room Sensors** - Room sensor (A2) is a two-wire thermistor with 1k series resistor.

**TABLE 2**  
**Two-Wire Thermistor**

Temp. °F (°C)	Resistance +/-2%	Temperature °F (°C)	Resistance +/-2%	Temp. °F (°C)	Resistance +/-2%
40 (4.4)	27,102	60 (15.6)	16,313	80 (26.7)	10,299
45 (7.2)	23,764	65 (18.3)	14,474	85 (29.4)	9,249
50 (10)	20,898	70 (21.1)	12,882	90 (32.2)	8,529
55 (12.8)	18,433	75 (23.9)	11,498		

**Carbon Dioxide Sensor** - The indoor carbon dioxide sensor (A63) is an analog sensor with a 0-10VDC output over a carbon dioxide range of 0-2000 ppm as shown in the following table. The sensor is powered with 24VAC.

**TABLE 3**  
**Carbon Dioxide Range**

Carbon Dioxide PPM	DCV	Carbon Dioxide PPM	DC Voltage	Carbon Dioxide PPM	DC Voltage	Carbon Dioxide PPM	DCV
0	0	600	3	1200	6	1800	9
200	1	800	4	1400	7	2000	10
400	2	1000	5	1600	8		

**VAV Supply Static Sensor** - The supply duct differential static pressure sensor (A30) is an analog sensor with a 0-10VDC output over a range of 0-5" w.c as shown in the following table. The sensor is powered with 24VAC.

**TABLE 4**  
**Static Pressure**

Pressure "w.c.	DCV	Pressure "w.c.	DC Voltage	Pressure "w.c.	DC Voltage	Pressure "w.c.	DCV
0	0	1.5	3	3	6	4.5	9
0.5	1	2	4	3.5	7	5	10
1	2	2.5	5	4	8		

**Relative Humidity Sensor - Option** - The indoor relative humidity sensor (A91) is an analog sensor with a 0-10VDC output over a relative humidity range of 0-100% relative humidity. The sensor is powered with 24VAC.

**Enthalpy Sensor - Option** - The optional enthalpy sensors (A7 and A63) used with the economizer have an output of 4-20mA. The sensor is powered with 18VAC provided by M3 unit control.

**Economizer Differential Pressure Sensor - Option** - Rooftop units installed with Smart Airflow™ will have a Pressure Transducer (PT5) present in the economizer. PT5 requires 5VDC power supply (P266-5 and {P266-6) and gives 0.25 VDC to 4 VDC output (P266-4) corresponding to 0" water column and 2" water column respectively. For all practical purposes the output should be less than 1.2" water column. If not an error code is stored and service alarm output is turned on.

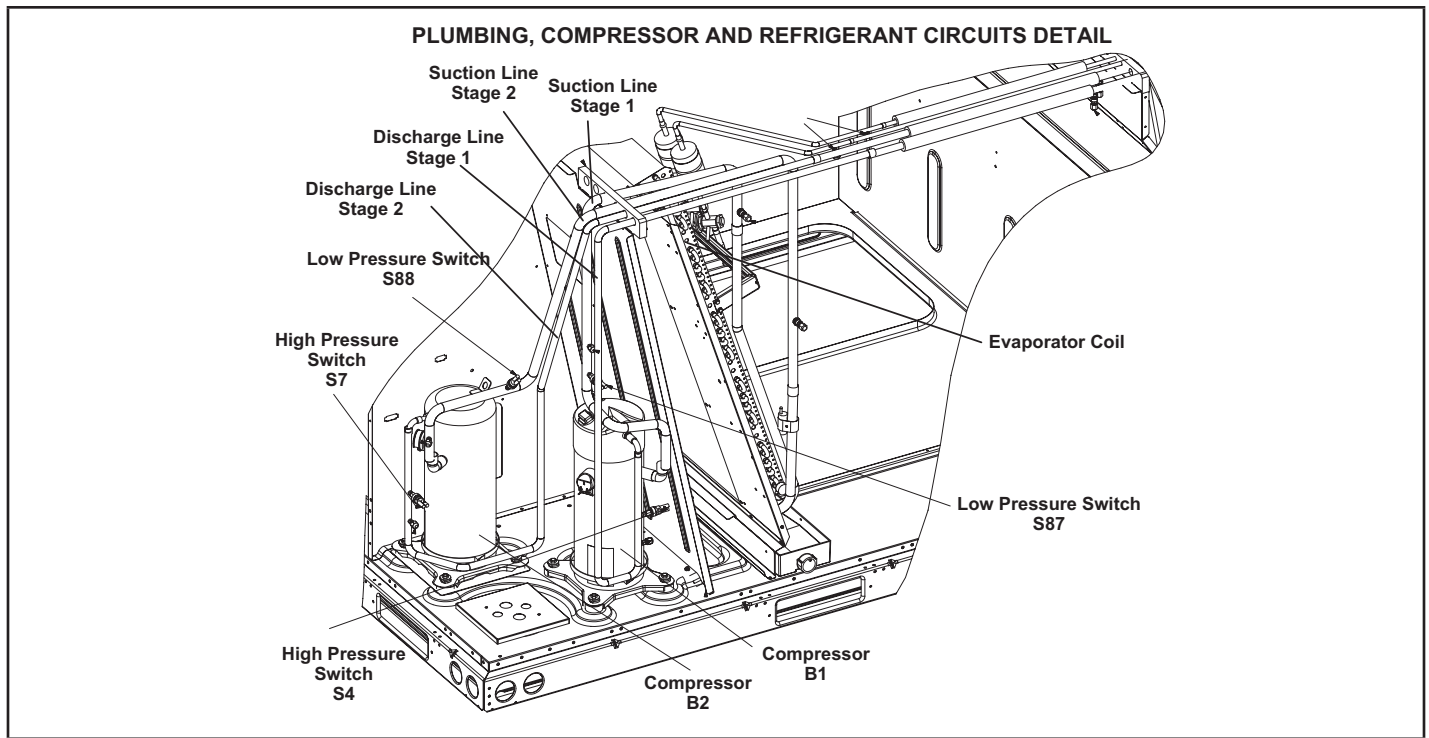

**FIGURE 6**

### B-Cooling Components

Units use two separate refrigeration circuits. Circuit 1 uses a variable speed compressor (B1) and Circuit two uses a fixed speed scroll compressor (B2). The single evaporator coil is row-split and return air first goes to circuit two before passing through circuit one. A single condenser coil is used that has interlaced circuits for circuit one and two. See FIGURE 6. Units are equipped with a direct drive blower which draws air across the evaporator during unit operation. Units are equipped with a single slab style evaporator. The evaporator uses two thermostatic expansions valves. Evaporators are equipped with enhanced fins and rifled tubing.

In all units, each compressor is protected by a crankcase heater, high pressure switch and low pressure switch. Additional protection comes from the use of temperature sensors that are located in the evaporator and condenser coils.

See sub-section 8 for more details on location of the thermistors (temperature sensors) for added compressor reliability. Cooling may be supplemented by a factory- or field-installed economizer.

#### 1-Compressors B1, B2

Units are equipped with one variable speed scroll and one fixed scroll compressor each operating on a separate cooling circuit. Compressor capacity may vary from stage to stage. In all cases, the capacity of each compressor is added to reach the total capacity of the unit. See "SPECIFICATIONS" and "ELECTRICAL DATA" (table of contents) or compressor nameplate for compressor specifications.

**⚠ WARNING**

**Electrical shock hazard. Compressor must be grounded. Do not operate without protective cover over terminals. Disconnect power before removing protective cover. Discharge capacitors before servicing unit. Failure to follow these precautions could cause electrical shock resulting in injury or death.**

Each compressor is energized by a corresponding compressor contactor, however contactor (K1) provides power to the compressor inverter (A192) which then controls the compressor according to a signal from unit controller (A55).

**NOTE-**Refer to the wiring diagram section for specific unit operation.

If Interlink compressor replacement is necessary, call 1-800-453-6669.

**⚠ IMPORTANT**

**Some scroll compressors have an internal vacuum protector that will unload scrolls when suction pressure goes below 20 psig. A hissing sound will be heard when the compressor is running unloaded. Protector will reset when low pressure in system rises above 40 psig. DO NOT REPLACE COMPRESSOR.**

## 2-Compressor Inverter A192

**⚠ WARNING**



Electrical Hazard  
High Voltage  
Wait 7 Minutes  
Electrical components may hold charge. Do not remove this panel or service this area for 7 minutes after the power has been removed.

**⚠ WARNING**

Electrical shock hazard. Variable speed compressor components must be grounded. Failure to follow these precautions could cause electrical shock resulting in injury or death.

See FIGURE 7 for compressor inverter controls located behind the hinged control panel.

The inverter varies the compressor speed (capacity) by converting an AC input signal to a pulse high voltage DC output. To initiate cooling operation, the Unit Controller (A55) supplies a control signal to the inverter (A192) via a MODBUS protocol. Inverter status and diagnostics are continuously monitored and reported to the Unit Controller such as:

- Improper Unit Controller input voltage compared to unit model number
- High input voltage
- Low input voltage
- Imbalanced input voltage
- A communication issue - check MODBUS communication wire for good connections between the Unit Controller and the inverter board. See TABLE 5 for inverter-related alarms. Inverter component wire routing is shown in FIGURE 8.

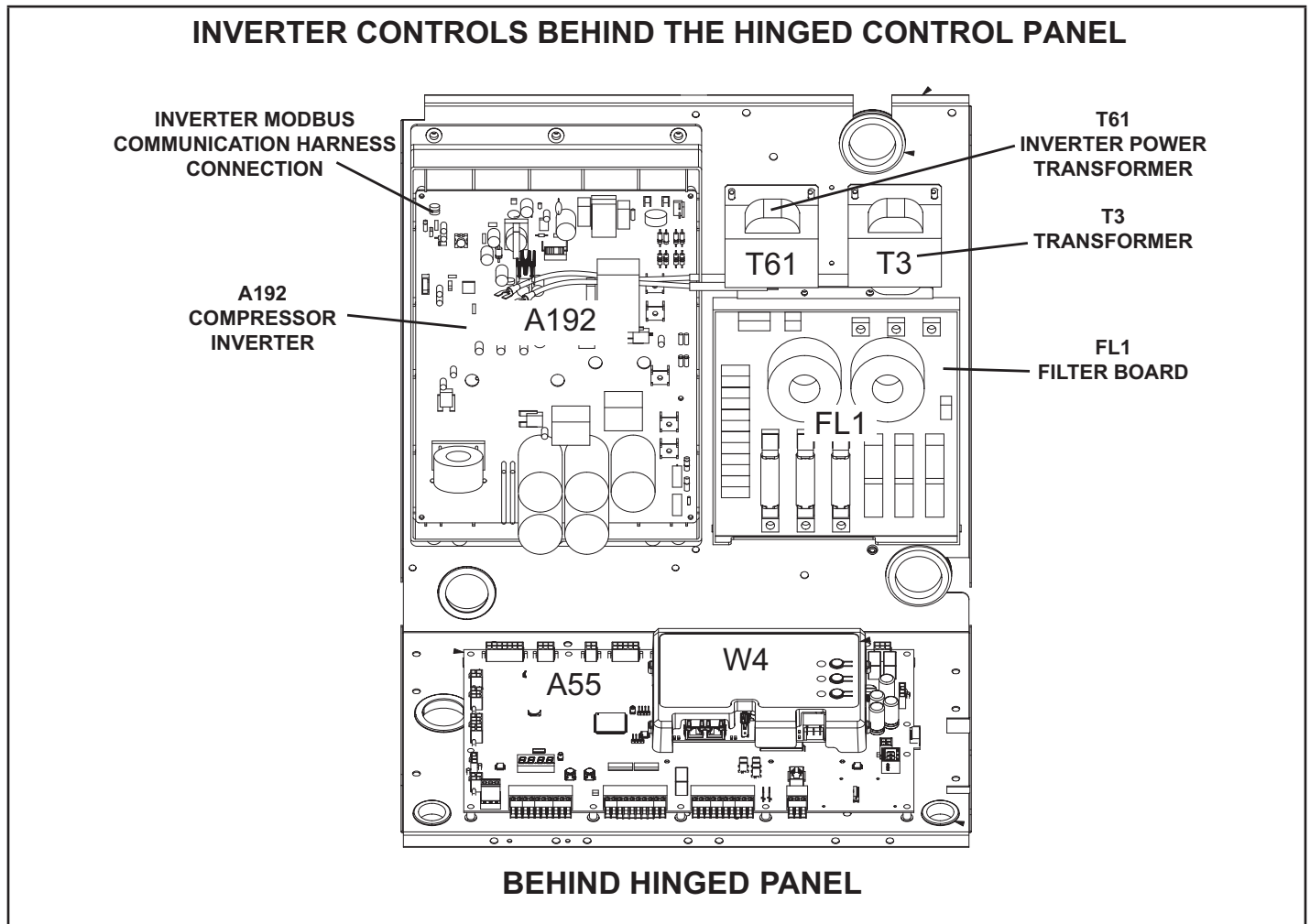

FIGURE 7

**TABLE 5  
INVERTER-RELATED ALARMS**

ALARM CODE	DISPLAY MESSAGE	EVENT ACTION
187	INVERTER LOW LEVEL ALARM	<p>Possible alarming values for Prodigy Alarm 187 are:            12 - High compressor input current            13 - High heat sink temperature            14 - High PFC input current</p> <p>Alarm might be caused by outdoor fan abnormal operation, high ambient conditions, dirty outdoor coil, refrigerant overcharge, or a blocked heat sink.</p> <p>The compressor speed will slow down until the temperature or current lowers, then the compressor will speed up again.</p> <p>If the alarm continues after outdoor conditions have moderated, check the fan, charge and coil. Alarm 187 will automatically clear when minimum off time expires.</p> <p><b>REFER TO TROUBLE SHOOTING GUIDE IN SERVICE MANUAL FOR MORE INFORMATION.</b></p>
188	INVERTER HIGH LEVEL ALARM	<p>Possible alarming values for Prodigy Alarm 188 are:            21 - Peak DC current - Intelligent Power Module (IPM) fault condition (follow 12)            22 - Maximum current reached lockout            23 - DC link low voltage            26 - Locked rotor            28 - DC link high voltage            29 - Compressor over-current            61 - Low outdoor ambient inverter lockout            62 - High heat sink temperature lockout            75 - Low input voltage</p> <p>No action required. Compressor stops for the duration of the minimum run time (anti-short-cycle delay of 180 seconds). Unit shuts down after ten occurrences in one hour and Alarm 189 is initiated. Alarm 188 will automatically clear when inverter error clears.</p> <p><b>REFER TO TROUBLE SHOOTING GUIDE IN SERVICE MANUAL FOR MORE INFORMATION.</b></p>
189	INVERTER FATAL ALARM	<p>Possible alarming values for Prodigy Alarm 189 are the same as alarm 188.</p> <p>Alarm 189 will clear upon manual reset.</p> <p><b>REFER TO TROUBLE SHOOTING GUIDE IN SERVICE MANUAL FOR MORE INFORMATION.</b></p>
190	INVERTER COMMUNICATION ERROR	<p>Unable to communicate with inverter. Unit Controller will disable compressor operation. Replace communication cable between inverter and M3 unit controller. If alarm continues, replace M3 unit controller or inverter.</p>
191	INVERTER VOLTAGE MISMATCH	<p>Unit Controller will disable compressor operation. Replace with correct inverter part.</p>

**a-Filter Board FL1**

The filter, also called a line or noise filter, is used to prevent static interference from outside sources. In addition, the filter prevents electrical interference from transferring to other appliances. The input voltage should read the same value as the output voltage. The same filter is used on all unit sizes and voltages.

**b-Inverter Transformer T61**

This transformer is used to supply power to the inverter's low voltage logic circuit. It also provides electrical isolation to protect sensitive components from electrical surges.

**c-Inverter Heat Sink**

The A192 inverter heat sink is cooled by B47 fan located behind the inverter mounting panel. The B47 fan can be accessed as shown by opening the filter access panel. Relay K191 provides power to the B47 fan through P417 Plug. The fan is always energized while the B1 Compressor is running. See FIGURE 9.

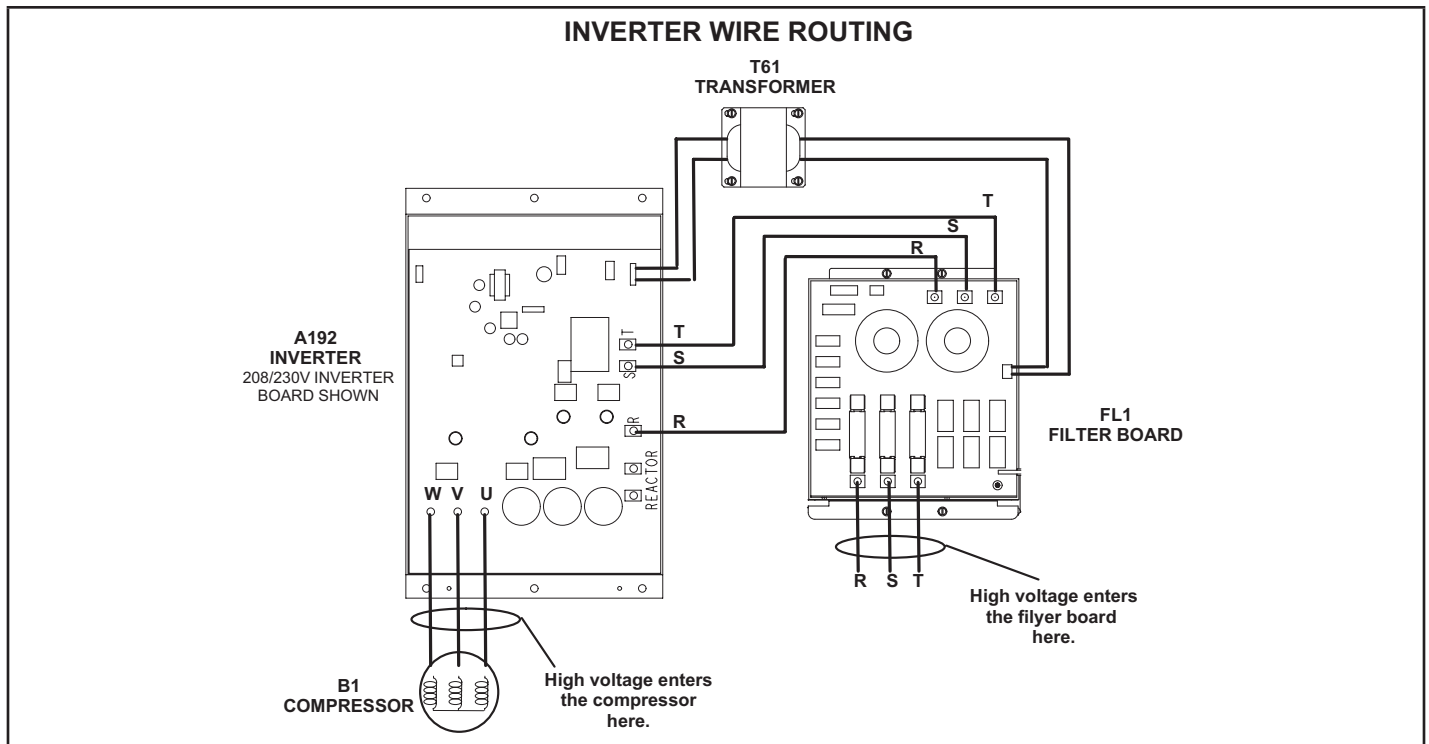

**FIGURE 8**

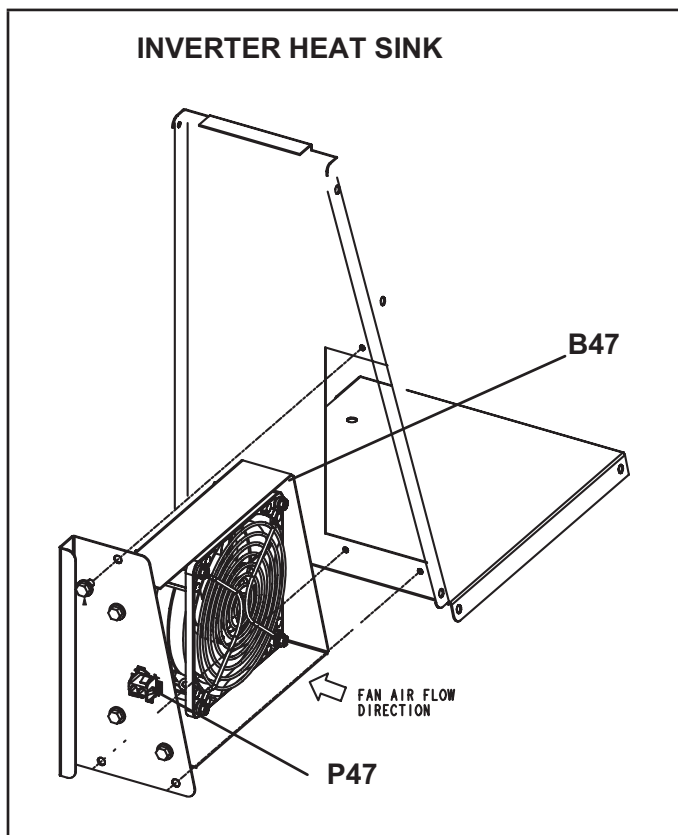

**FIGURE 9**

### 3-Crankcase Heaters HR1, HR2

All LGM units use insertion type heaters. Heater HR1 is installed around compressor B1 and heater HR2 is installed around compressor B2. Crankcase heater wattage varies by compressor size. Power to crankcase heater (HR1) is controlled through the K191 relay and power to HR2 controlled by auxiliary contact on K2 compressor contactor that is normally closed.

### 4-High Pressure Switches S4, S7

The high pressure switch is an auto-reset SPST N.C. which opens on a pressure rise. The switch is located in the compressor discharge line and is wired to the compressor contactor via controller A55. S4 protects compressor B1 and S7 protects compressor B2. S4 is wired to the K1 contactor that disables power to the A192 Compressor Variable Speed Inverter. S7 is wired to the K2 contactor that disables the B2 compressor.

When discharge pressure rises to  $640 \pm 10$  psig ( $4413 \pm 69$  kPa) (indicating a problem in the system) the switch opens and the respective compressor is de-energized (the economizer can continue to operate). When discharge pressure drops to  $475 \pm 20$  psig ( $3275 \pm 138$  kPa) the pressure switch will close.

The A55 Unit Controller has a three-strike counter before locking out. This means the control allows three high pressure trips per one thermostat demand. The control can be reset by breaking and remaking the thermostat demand or manually resetting the control.

## 5-Filter Drier

LGM units have a filter drier located in the liquid line of each refrigerant circuit. See FIGURE 6. The drier removes contaminants and moisture from the system.

## 6-Low Pressure Switches S87, S88

The low pressure switch is an auto-reset SPST N.O. switch (held N.C. by refrigerant pressure) which opens on a pressure drop. All units are equipped with this switch. The switch is located in the compressor suction line and wired to A55 unit controller.

A55 governs the low pressure switches by shunting the switches during start up until pressure is stabilized. After the shunt period, the control has a three-strike counter, during first thermostat demand, before the compressor is locked out. The control is reset by breaking and remaking the thermostat demand or manually resetting the control.

When suction pressure drops to  $40 \pm 5$  psig ( $276 \pm 34$  kPa), (indicating low pressure), the switch opens and the compressor(s) is(are) de-energized. The switch automatically resets when pressure in the suction line rises to  $90 \pm 5$  psig ( $620 \pm 34$  kPa) due to many causes such as refrigerant being added.

## 7-Condenser Fans B4 and B5

See SPECIFICATIONS tables at the front of this manual for specifications of condenser fans used in all units. All condenser fans have single-phase motors. The fan assembly may be removed for servicing and cleaning.

Units are equipped with electronically commutated condenser fan motors (ECM). The ECM motors are wired directly to 230VAC power but do not operate until a pulse width modulated (PWM) control signal is sent from the A55 Unit Controller. The PWM signal determines the condenser fan speed. Both fans will operate in low speed with a Y1 demand and both will will operate in high speed with a Y2 demand.

**Transformer T5 and Fuse F57 460VAC & 575VAC only**  
460VAC and 575VAC units will use a Transformer T5 to step-down the line voltage to the correct 230VAC. There are two fuses (F57) located next to the T5 transformer. The location of the T5 transformer is behind the disconnect box just above the bottom power entry cover.

Both low and high voltage plugs are located at the top of the blower compartment in the indoor section of the unit. Condenser fan motors B4 and B5 high voltage plugs are J86, and J87. Low voltage plugs are J336 and J338 respectively.

Refer to wiring markings to identify plugs.

If an ECM fan is not operating:

- 1 - Check to make sure high voltage is present before checking low voltage.
- 2 - Read the voltage at the appropriate high voltage fan motor plug (J86 or J87) using the VAC meter setting.
- 3 - If high voltage is present, check the low voltage plug (J336 or J337) for a signal from the Unit Controller. Use either the duty cycle (%) or a VDC meter setting.

**Note** - The VDC reading may fluctuate and is normal for a PWM signal.

## 8-Temperature Sensors RT42, RT43, RT44, RT45, RT46, RT47, RT48, and RT49

Units are equipped with eight factory-installed thermistors (RT42 - RT49) located on different points on the refrigerant circuit.

The thermistors provide the Unit Controller with constant temperature readings of four specific locations on the refrigeration circuit. These temperatures are used as feedback in certain modes of unit operation. In addition, the Unit Controller uses these temperatures to initiate alarms such as loss of condenser or evaporator airflow and loss of charge.

Each thermistor must be specifically placed for proper unit operation and to initiate valid alarms. See FIGURE 10 and FIGURE 11 for proper locations.

LGM/LCM092, 102, 120, 150  
 EVAPORATOR COIL  
 RT42, 43, 46, 47

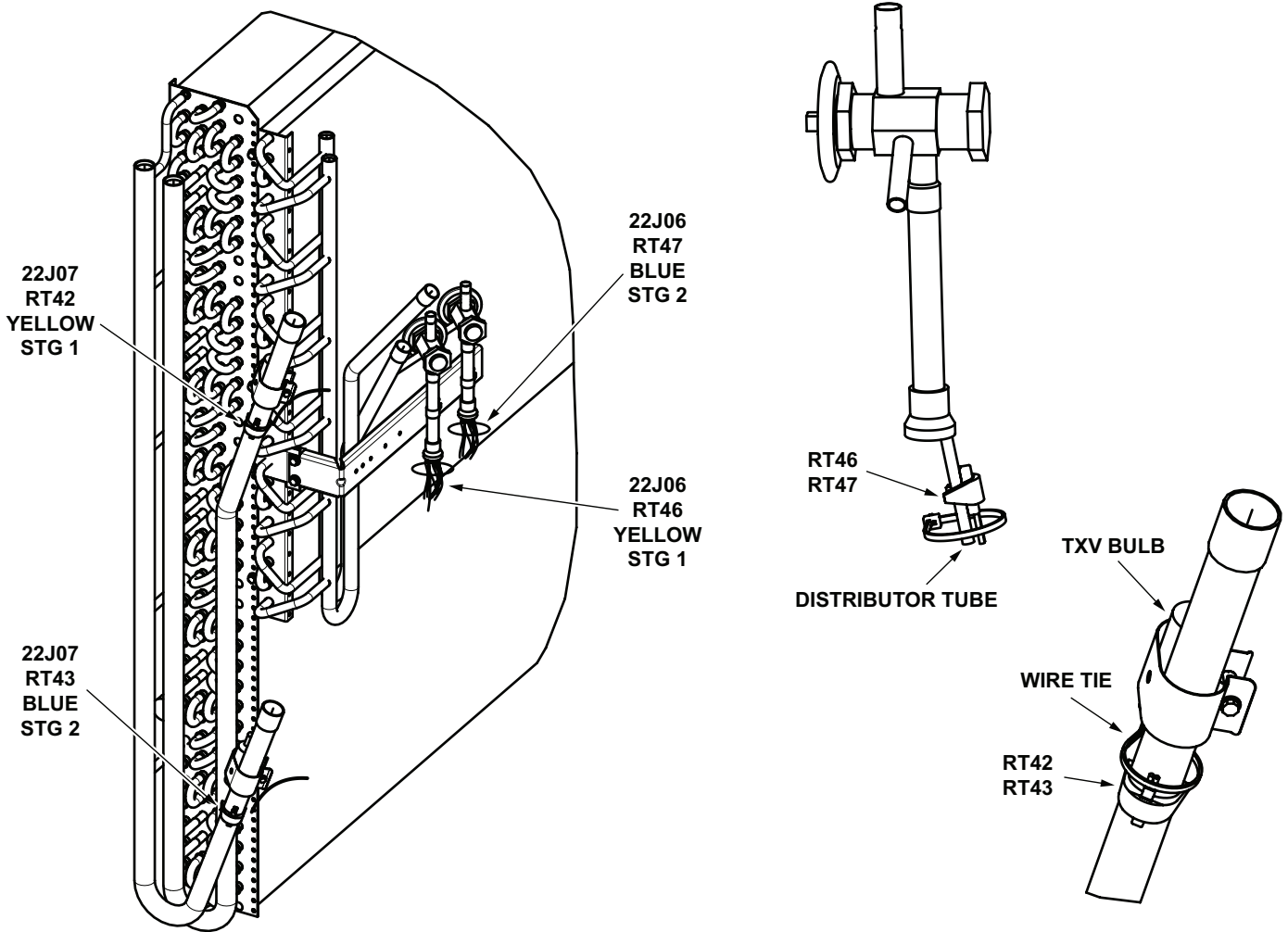

FIGURE 10

LGM/LCM092, 102, 120, 150  
CONDENSER COIL  
RT44, 45, 48, 49

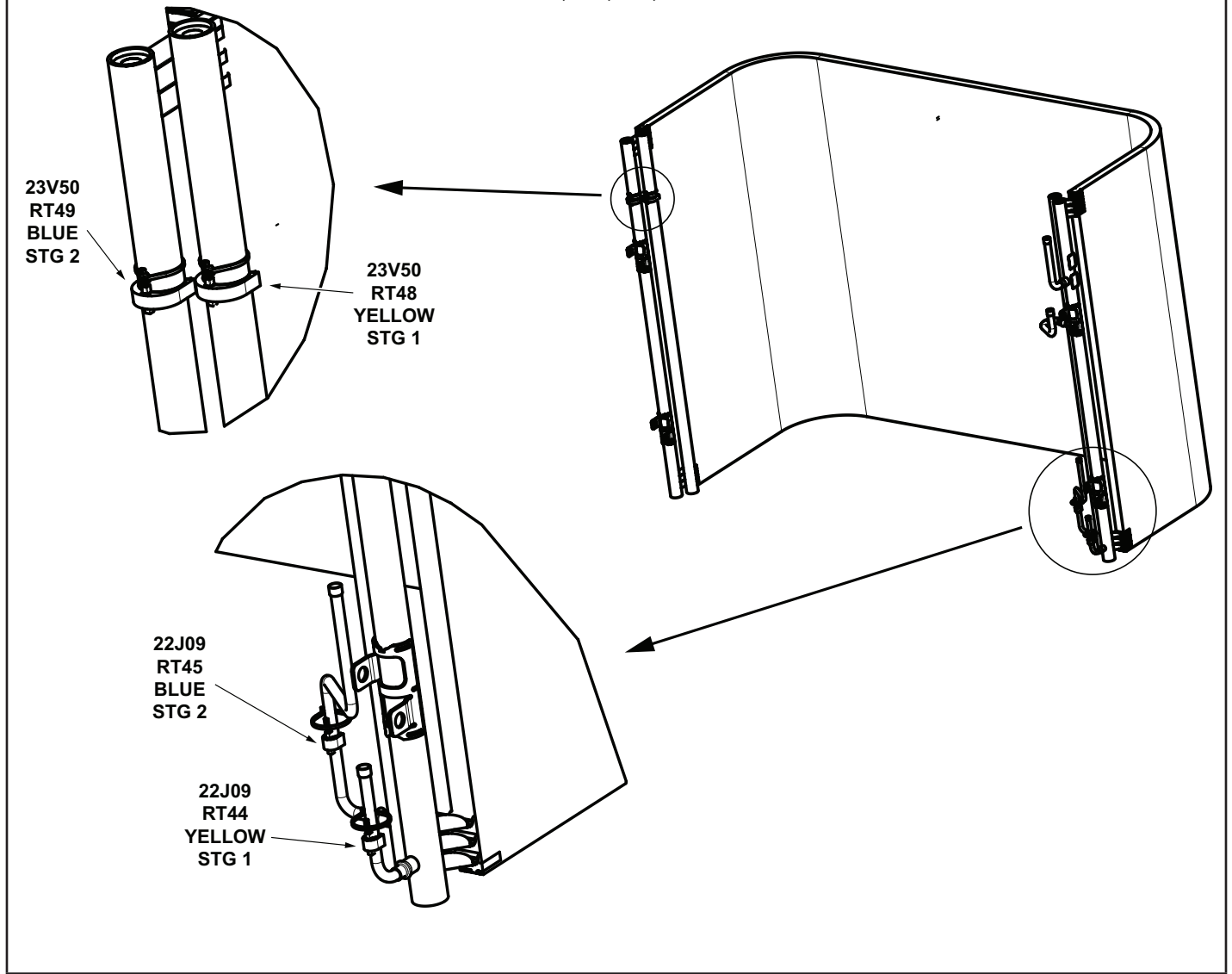

FIGURE 11

## 9 - RDS Sensor

Units are equipped with a factory-installed RDS sensor located on the indoor compartment. See FIGURE 12. The RDS sensor provides the Unit Controller with continuous readings for leaked refrigerant concentration levels and sensor health status (Good or Fault). These readings are used to modify unit operation to disperse the leaked refrigerant and to remove possible ignition sources. In addition, the Unit Controller uses these readings to initiate alarms to alert the operator of a refrigerant leak or faulty sensor(s).

The sensor must be specifically placed (FIGURE 12) for proper unit operation and to initiate valid alarms

The RDS Sensor and Controller shall only be replaced with parts specified by the appliance manufacturer.

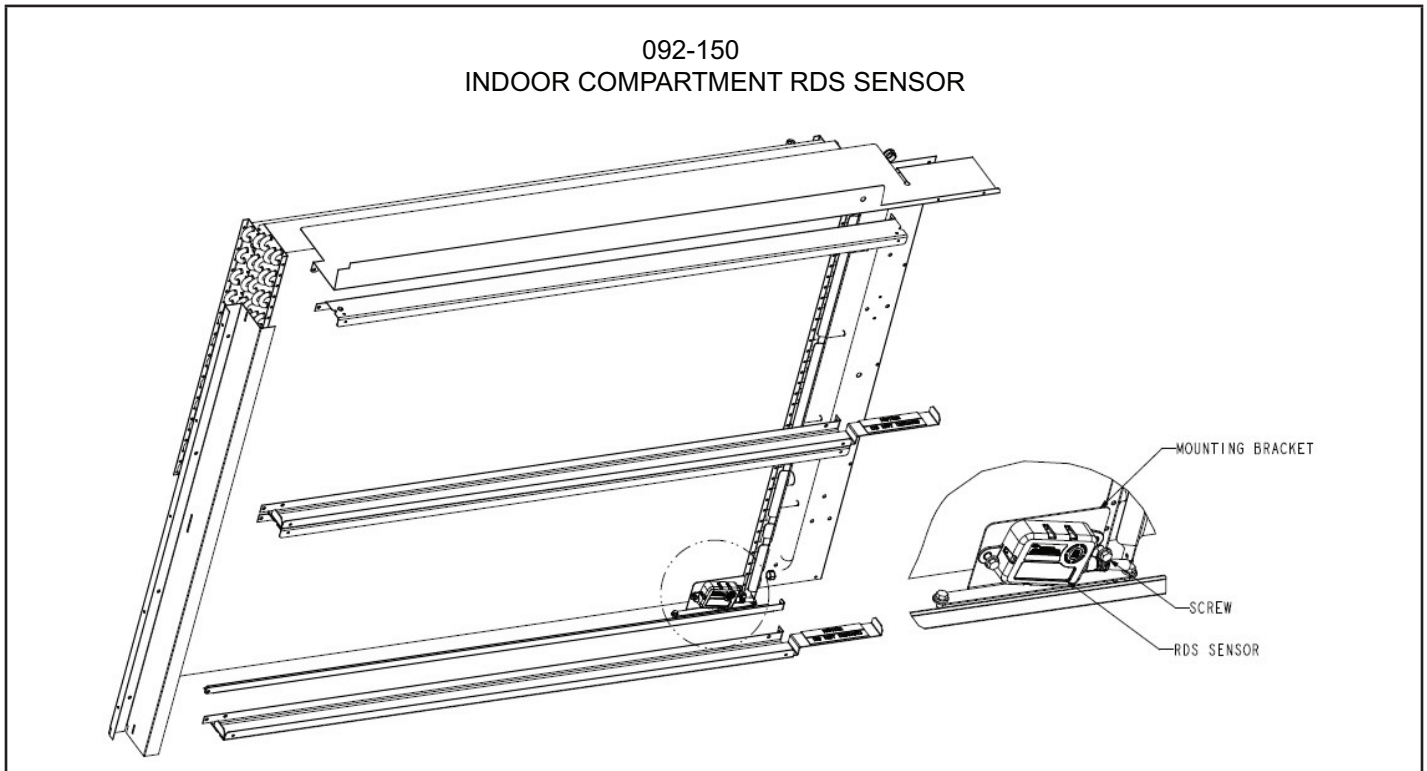

FIGURE 12

## C-Blower Compartment

The blower compartment is located between the evaporator coil and the condenser coil section. The blower assembly is secured to a sliding frame which allows the blower motor assembly to be pulled out of the unit.

### 1-Blower Wheels

Units are equipped with an optional direct drive blower assembly with a backward inclined blower wheel.

### 2-Indoor Blower Motor B3

Units are equipped with a direct drive blower assembly with a three-phase, variable speed, direct drive blower motor. All motor specifications are listed in the SPECIFICATIONS (table of contents) in the front of this manual. Units may be equipped with motors manufactured by various manufacturers, therefore electrical FLA and LRA specifications will vary. See unit rating plate for information specific to your unit.

### A-Blower Operation

Refer to the Unit Controller Setup Guide to energize blower. Use the mobile service app menu; see SERVICE > TEST. In thermostat control mode, the Unit Controller will stage the blower between low and high speed. In zone sensor control mode, the Unit Controller will vary (VAV) the blower between low and high speed.

## WARNING

- 1-Make sure that unit is installed in accordance with the installation instructions and applicable codes.
- 2-Inspect all electrical wiring, both field-and factory installed, for loose connections. Tighten as required.
- 3-Check to ensure that refrigerant lines do not rub against the cabinet or against other refrigerant lines.
- 4-Check voltage at disconnect switch. Voltage must be within range listed on nameplate. If not, consult power company and have voltage condition corrected before starting unit.
- 5-Make sure filters are new and in place before start-up.

Initiate blower only (G) demand at thermostat according to instructions provided with thermostat. Unit will cycle on thermostat demand. The following steps apply to applications using a typical electro-mechanical thermostat.

- 1 - Blower operation is manually set at the thermostat subbase fan switch. With fan switch in ON position, blowers will operate continuously.
- 2 - With fan switch in AUTO position, the blowers will cycle with demand. Blowers and entire unit will be off when system switch is in OFF position.

**NOTE** - Blower operation mode can also be initiated by the mobile service app.

### B-Blower Access

The blower assembly is secured to a sliding frame which allows the blower assembly to be pulled out of the unit. See FIGURE 14.

- 1 - Loosen the reusable wire tie which secures the controls and high voltage blower wiring to the blower housing. Disconnect the pressure sensor low voltage wire harness.
- 2 - Remove and retain screws on either side (and on the front for direct drive) of sliding frame. Use the metal handle to pull frame toward outside of unit.
- 3 - Slide frame back into original position when finished servicing. Reattach the blower wiring in the previous location using the wire tie. Reconnect pressure sensor low voltage wire harness.
- 4 - Replace retained screws.

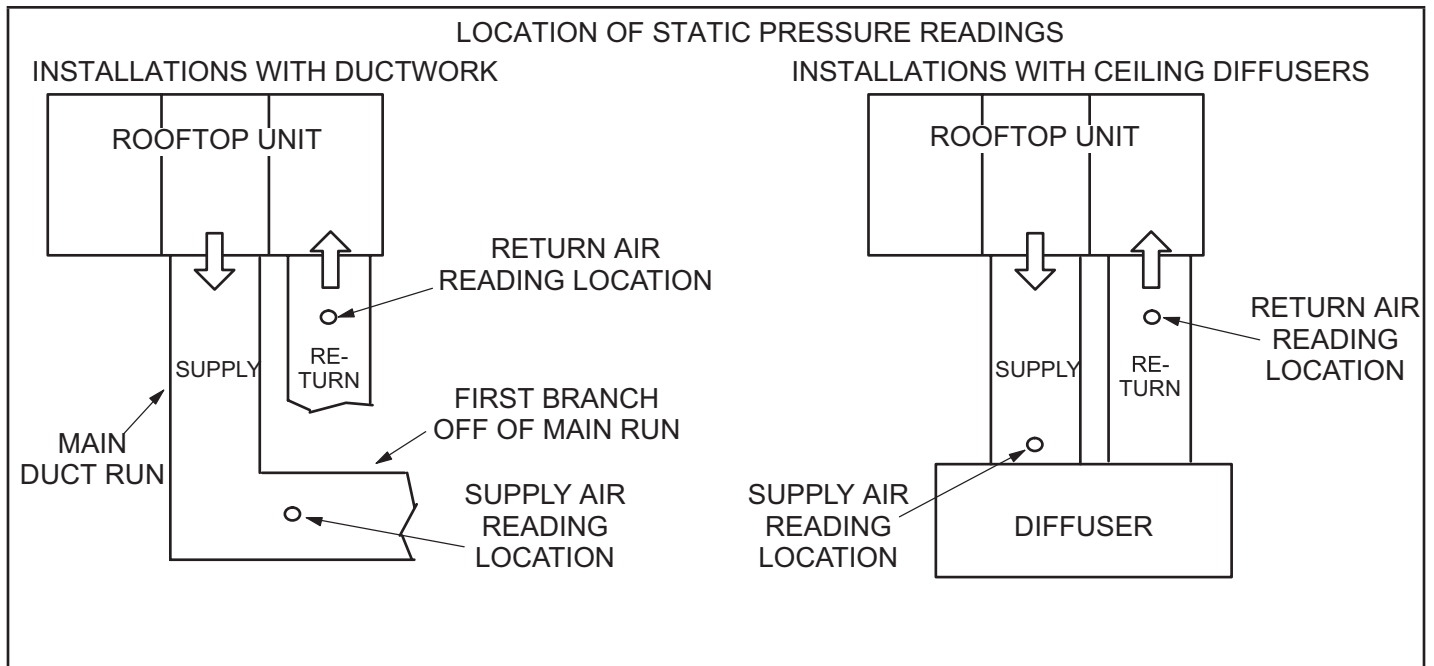

**FIGURE 13**

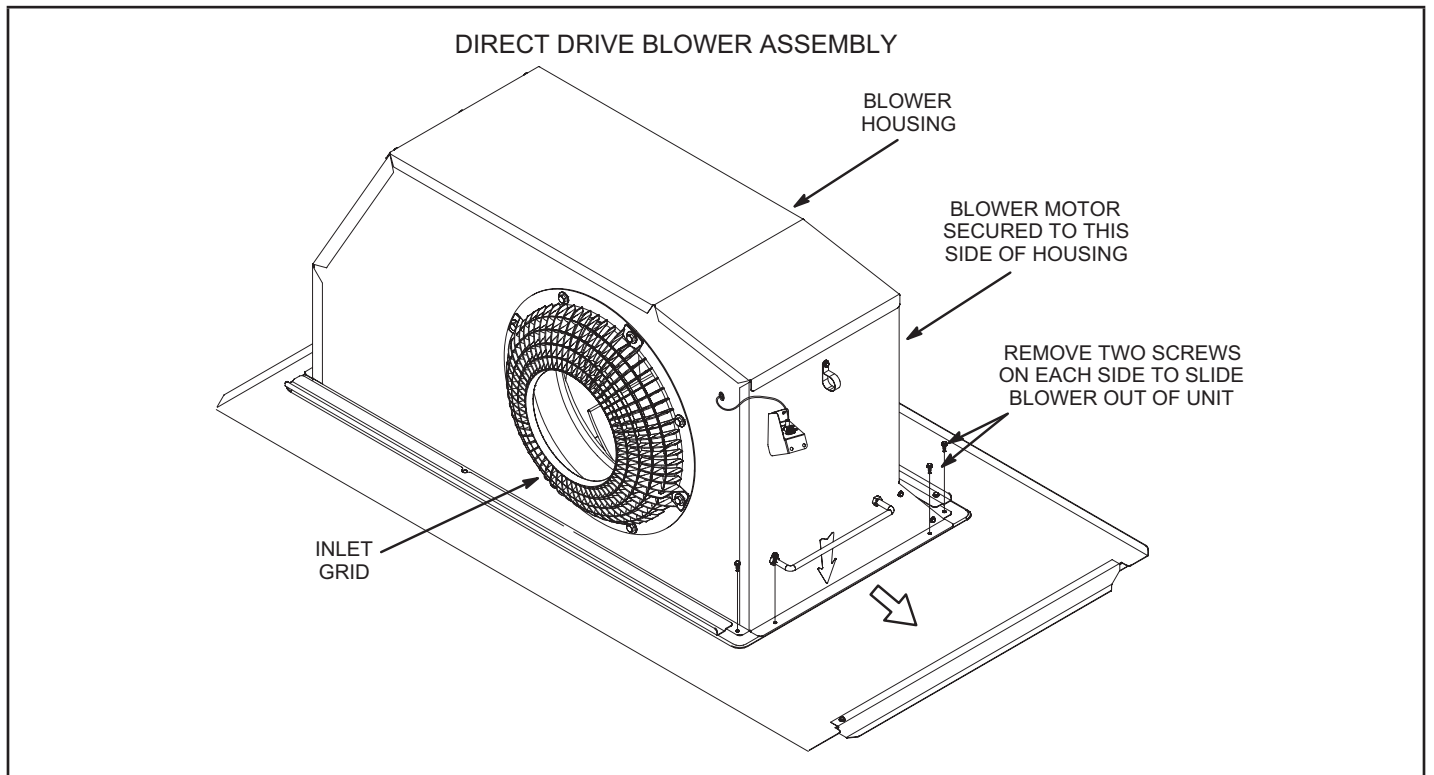

**FIGURE 14**

## Direct Drive Start-Up

The supply CFM can be adjusted by changing Unit Controller settings. Refer to TABLE 6 for menu paths and default settings. Record any CFM changes on the parameter settings label located on the inside of the compressor access panel.

### IMPORTANT

The BLOWER CALIBRATION process starts the in door blower at operational speeds and moves the economizer damper blades. Before starting this process, replace any access panels and close all unit doors except compressor compartment door.

Blower calibration is required only on units that are newly installed or if there is a change in the duct work or air filters after installation. Use the mobile service app to navigate to the SETUP > TEST & BALANCE > BLOWER menu. After the new CFM values are entered, select START CALIBRATION.

The blower calibration status is displayed as a % complete. Upon successful completion, the mobile service app will display CALIBRATION SUCCESS and go back to the blower calibration screen.

IMPORTANT - The default value for Cooling Low CFM is lower than a traditional single- or two-speed unit. If operating the unit with a 2- or 3-stage thermostat, DDC controller, etc.), it is recommended to increase the Cooling Low CFM default value to a suitable level for part load cooling (typically 60% of full load CFM).

**TABLE 6**  
**DIRECT DRIVE PARAMETER SETTINGS**

Parameter	Factory Setting				Field Setting	Description
	092	102	120	150		
<b>NOTE - Any changes to Smoke CFM setting must be adjusted before the other CFM settings. Use SETTINGS &gt; RTU OPTIONS &gt; EDIT PARAMETERS = 12</b>						
BLOWER SMOKE CFM	3000	3400	4000	5000	CFM	Smoke blower speed
<b>SETUP &gt; TEST &amp; BALANCE &gt; BLOWER</b>						
BLOWER HEATING HIGH CFM	3000	3400	4000	5000	CFM	Heating blower speed
BLOWER COOLING HIGH CFM	2625	2975	3500	4375	CFM	High cooling blower speed
BLOWER COOLING LOW CFM	800	800	875	1100	CFM	Low cooling blower speed
BLOWER VENTILATION CFM	800	800	875	1100	CFM	Ventilation blower speed
<b>SETUP &gt; TEST &amp; BALANCE &gt; DAMPER</b>						
BLOWER HIGH CFM DAMPER POS %	0%	0%	0%	0%	%	Minimum damper position for high speed blower operation.
BLOWER LOW CFM DAMPER POS %	0%	0%	0%	0%	%	Minimum damper position for low speed operation.
BLOWER EXHAUST DAMPER POS %	50%	50%	50%	50%	%	Minimum damper position for power exhaust operation.
<b>SETTINGS &gt; RTU OPTIONS &gt; EDIT PARAMETERS = 216</b>						
POWER EXHAUST DEADBAND %	10%	10%	10%	10%	%	Deadband % for power exhaust operation.
<b>SETTINGS &gt; RTU OPTIONS &gt; EDIT PARAMETER = 10 (Applies to Thermostat Mode ONLY)</b>						
FREE COOLING STAGE-UP DELAY	300 sec.	300 sec.	300 sec.	300 sec.	sec	Number of seconds to hold indoor blower at low speed before switching to indoor blower at high speed.

Installer - Circle applicable unit model number and record any parameter changes under "Field Setting" column. Settings need to be recorded by installer for use when Unit Controller is replaced or reprogrammed.

**TABLE 7  
DIRECT DRIVE BLOWER MOTOR TROUBLESHOOTING**

<b>Failure</b>	<b>Error</b>	<b>Warning</b>	<b>Reason</b>	<b>Troubleshoot</b>
Locked Rotor	•		No changes in hall signals within 2000ms	Check for obstruction keeping impeller from rotating
Braking Mode		•	Warning, no error code set, Motor start not possible after 20 sec	Check for secondary airflow source in the system causing the impeller to rotate backwards when off
Hall Error	•		Combination of 3 hall signals gives false signal after one rotation	Measure voltage across each leg, Check electrical connections
Power Module Overheated	•		Temperature > 115°C	Check operating conditions in blower compartment, Check for high motor load (current draw), Check for corrosion-free and secure electrical connections
Motor Overheated	•		Motor over-temperature protector opens	
Gate Driver Error	•		Internal software fault	Measure voltage across each leg, Check electrical connections
Phase Failure	•		Input voltage has phase imbalance	Measure voltage across each leg, Check electrical connections, Repair low/high voltage leg(s)
DC Link Voltage Low	•		Rectified DC link voltage is too low	
DC Link Over-voltage	•		Rectified DC link voltage is too high	
Line Over-voltage	•		Line voltage too high	
Line Under-voltage	•		Line voltage too low	
Communication Error	•		Internal communication failure. Not connected with master/ slave wiring	Check low voltage wiring connections
DC Link Voltage Low		•	Warning, not low enough to set error code	Measure voltage across each leg, Check electrical connections, Repair low/high voltage leg(s)
Electronics Temp High		•	Warning, not high enough to set error code, Temperature > 95°C	Check operating conditions in blower compartment, Check for high motor load (current draw), Check for corrosion-free and secure electrical connections
Power Module Temp High		•	Warning, not high enough to set error code, Temperature > 105°C	
Motor Temp High		•	Warning, not high enough to set error code, Temperature > 130°C	

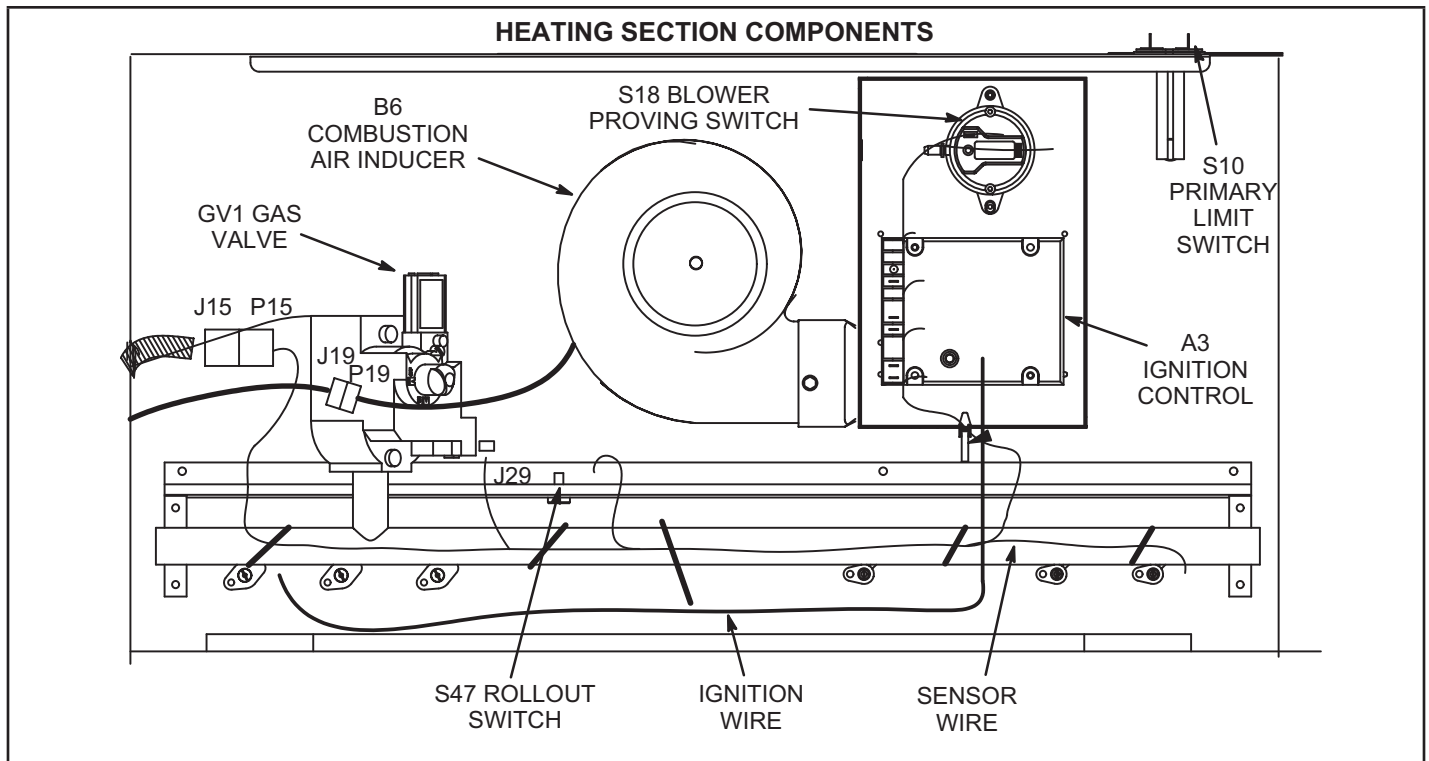

FIGURE 15

### D-GAS HEAT COMPONENTS

See SPECIFICATIONS tables or unit nameplate for Btuh capacities. Units are equipped with two identical gas heat sections (gas heat section one and gas heat section two). Flexible pipe will feed supply gas to both sections.

If for service the flexible connection must be broken, hand tighten then turn additional 1/4" with a wrench for metal to metal seal (do not overtighten).

**NOTE** - Do not use thread sealing compound on flex pipe flare connections.

#### 1-Control Box Components A3, A12, A55

**⚠ WARNING**

Shock hazard. Spark related components contain high voltage which can cause personal injury or death. Disconnect power before servicing. Control is not field repairable. Unsafe operation will result. If control is inoperable, simply replace the entire control.

#### Burner Ignition Control A3

The ignition control is located in the heat section area. The control is manufactured UTEC. See TABLE 8 for LED codes. The ignition control provides three main functions: gas valve control, ignition and flame sensing. The unit will usually ignite on the first attempt; however, the ignition attempt sequence provides three trials for ignition before locking out.

The lockout time for the control is 5 minutes. After lockout, the ignition control automatically resets and provides three more attempts at ignition. Manual reset after lockout requires breaking and remaking power to the ignition control. See FIGURE 16 for a normal ignition sequence and FIGURE 17 for the ignition attempt sequence with retries (nominal timings given for simplicity). Specific timings for the ignition controls are shown in FIGURE 18.

**TABLE 8**  
**UTEC**

LED Flashes	Indicates
Slow Flash	Control ok, no call for heat.
Fast Flash	Control ok, call for heat present.
Steady Off	Internal control fault or no power.
Steady On Failure	Control internal failure.
1 Flash	Rollout switch open.
2 Flashes	Limit open or lockout from too many tries during a single heat demand.
3 Flashes	Pressure switch open with inducer on/ open during 5 minute inducer off time.
4 Flashes	Ignition lockout from no flame detected or from too many flame losses.
5 Flashes	Flame sensed out of sequence.
6 Flashes	Pressure switch closed with inducer off.
7 Flashes	Gas valve relay failure.
8 Flashes	Lockout due to too many pressure switch openings during one heat demand

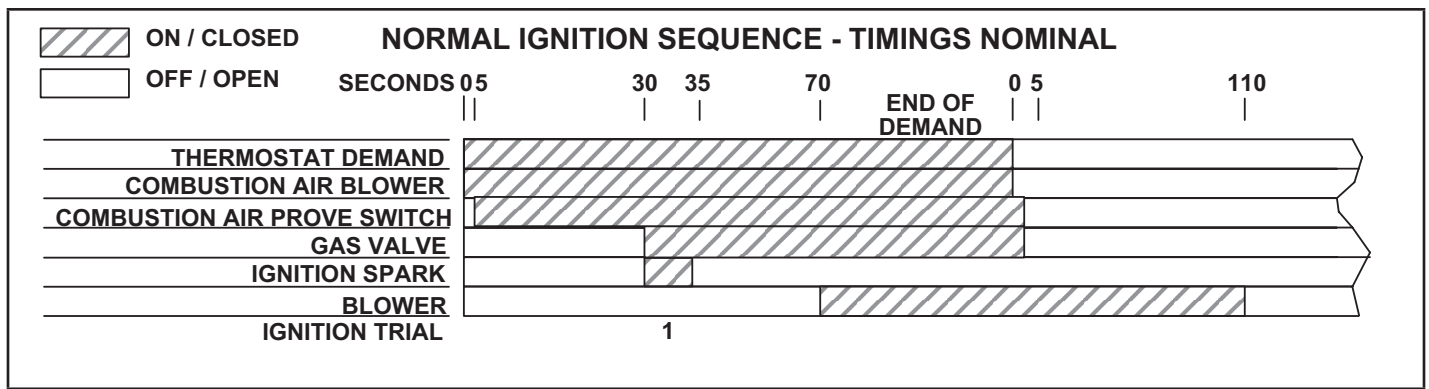

FIGURE 16

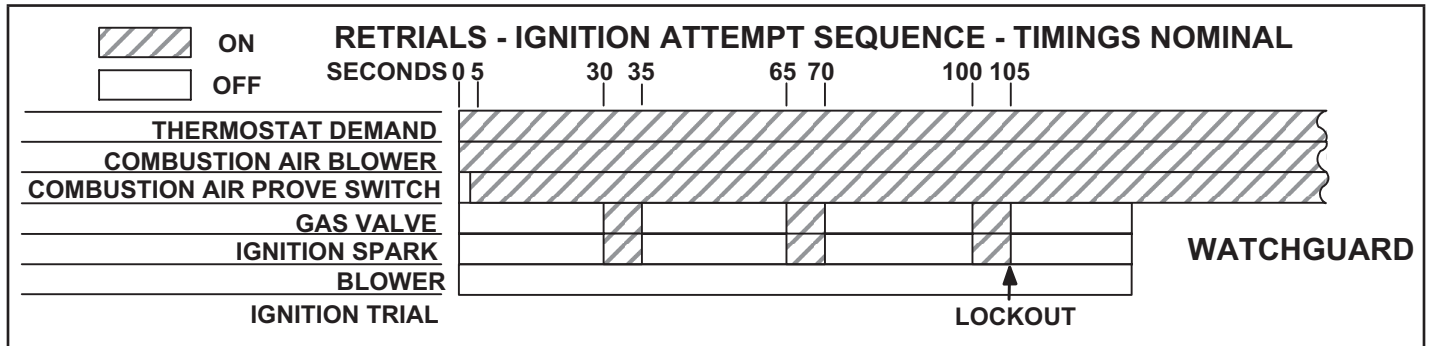

FIGURE 17

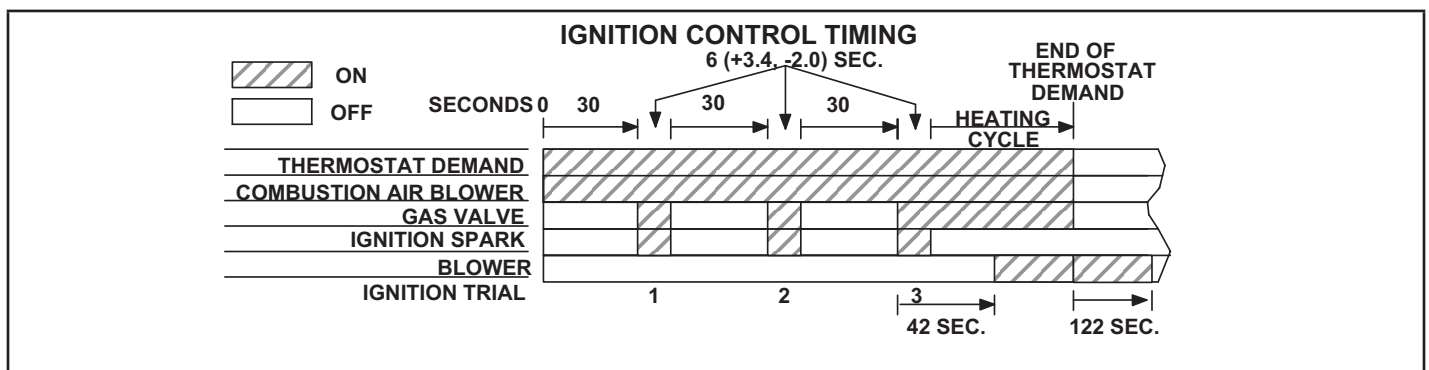

FIGURE 18

Flame rectification sensing is used on all units. Loss of flame during a heating cycle is indicated by an absence of flame signal (0 microamps). If this happens, the control will immediately restart the ignition sequence and then lock out if ignition is not gained after the third trial. See System Service

Checks section for flame current measurement. The control shuts off gas flow immediately in the event of a power failure. Upon restoration of gas and power, the control will restart the ignition sequence and continue until flame is established or system locks out.

On a heating demand, the ignition control is energized by the A55 Unit Controller. The ignition control then allows 30 to 40 seconds for the combustion air blower to vent exhaust gases from the burners.

When the combustion air blower is purging the exhaust gases, the combustion air proving switch is closing proving that the combustion air blower is operating before allowing the ignition control to energize. When the combustion air proving switch is closed and the delay is over, the ignition control activates the gas valve, the spark electrode, and the flame sensing electrode. Sparking stops immediately after flame is sensed. The combustion air blower continues to operate throughout the heating demand. If the flame fails or if the burners do not ignite, the ignition control will attempt to ignite the burners up to two more times. If ignition cannot be obtained after the third attempt, the control will lock out. The ignition control is not adjustable.

## 2-Heat Exchanger FIGURE 19

The LGM units use aluminized steel inshot burners with matching tubular aluminized (stainless steel is an option) steel heat exchangers and two-stage redundant gas valves. Units are equipped with one eleven tube/burner for high heat, one nine tube/burner for medium heat, and one six tube/burner for standard heat. Burners use a burner venturi to mix gas and air for proper combustion.

Combustion takes place at each tube entrance. As hot combustion gases are drawn upward through each tube by the combustion air blower, exhaust gases are drawn out the top and fresh air/gas mixture is drawn in at the bottom. Heat is transferred to the air stream from all surfaces of the heat exchanger tubes. The supply air blowers, controlled by the A55 Unit Controller, force air across all surfaces of the tubes to extract the heat of combustion. The shape of the tubes ensures maximum heat exchange. The gas valves accomplish staging by allowing more or less gas to the burners as called for by heating demand.

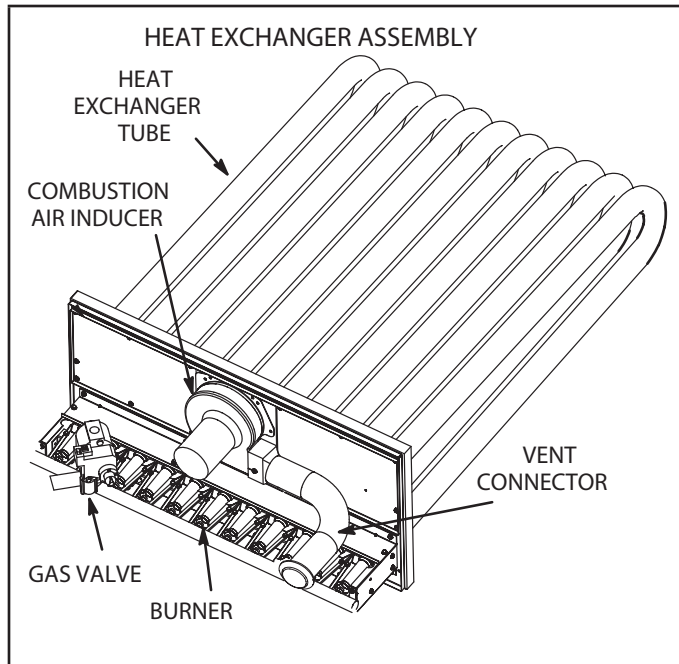

FIGURE 19

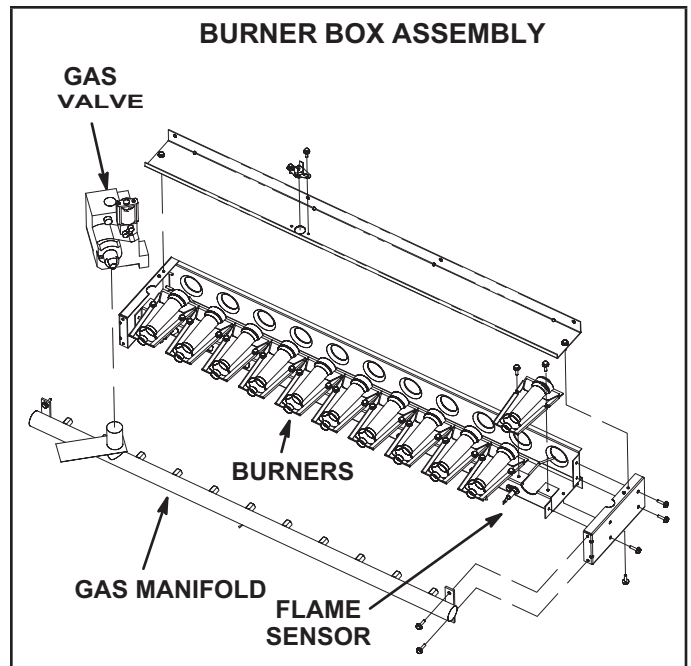

FIGURE 20

## 3-Burner Assembly (FIGURE 20)

The burners are controlled by the spark electrode, flame sensing electrode, gas valve and combustion air blower. The spark electrode, flame sensing electrode and gas valve are directly controlled by ignition control. Ignition control and combustion air blower is controlled by A55 Unit Controller.

### **Burners**

All units use inshot burners (see FIGURE 21). Burners are factory set and do not require adjustment. A peep hole with cover is furnished in the heating access panel for flame viewing. Always operate the unit with the access panel in place. Burners can be removed individually for service. Burner maintenance and service is detailed in the SERVICE CHECKS section of this manual.

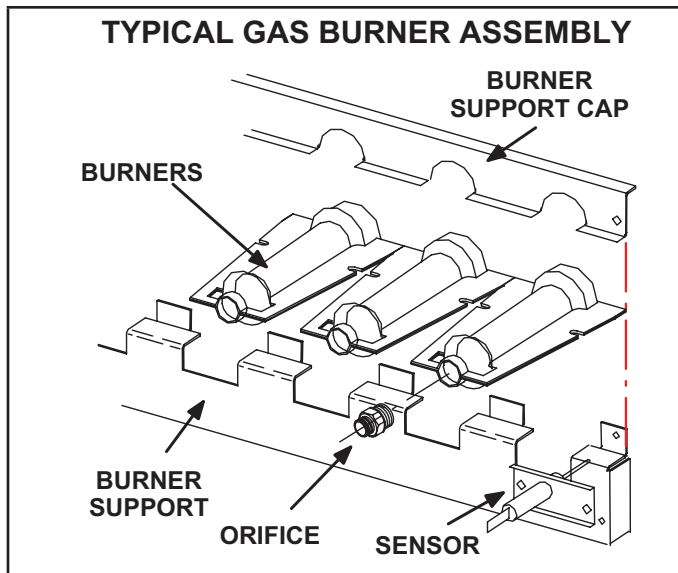

**FIGURE 21**

**Orifice**

Each burner uses an orifice (FIGURE 22) which is precisely matched to the burner input. Install only the orifices with the same threads. The orifice is threaded into the burner manifold. The burner is supported by the orifice and will easily slide off for service. Each orifice and burner are sized specifically to the unit.

**NOTE-**Do not use thread sealing compound on the orifices. Using thread sealing compound may plug the orifices. Each orifice and burner are sized specifically to the unit. Refer to [ProductZone@www.davenet.com](mailto:ProductZone@www.davenet.com) for correct sizing information.

**4-Primary High Temperature Limits S10**

S10 is the primary high temperature limit and is located on the blower deck to the right of the blower housing.

Primary limit S10 is wired to the A3 ignition control which energizes burner 1 control (A3). Its N.C. contacts open to de-energize the ignition control when excessive temperature is reached in the blower compartment. The A55 unit controller will energize the B4 blower whenever it senses that the S10 limit has been opened. If the limit trips the blower will be energized. Limit settings are factory set and cannot be adjusted. If limit must be replaced, the same type and set point must be used.

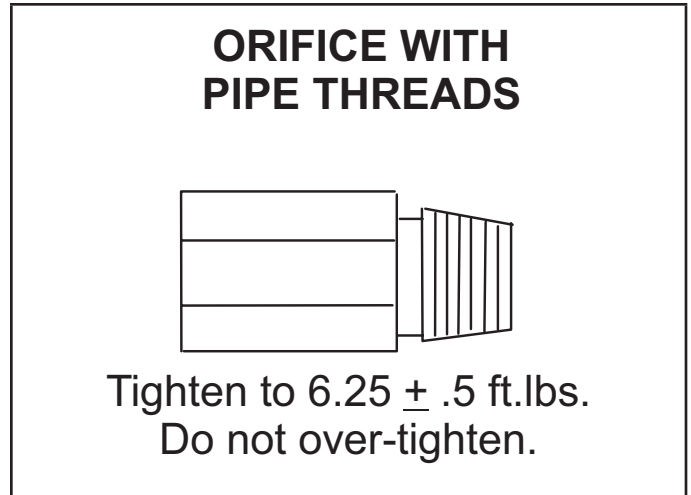

**FIGURE 22**

### 5-Flame Roll-out Limit S47

Flame roll-out limit S47 is a SPST N.C. high temperature limit located as shown in FIGURE 15. S47 is wired to the A3 ignition controller. When S47 senses flame roll-out (indicating a blockage in the combustion air passages), the flame roll-out limit trips and the ignition control immediately closes the gas valve.

Limit S47 is factory preset to open at 290F ± 12F (143.3C ± 6.7C) on a temperature rise. All flame roll-out limits are manual reset.

### 6-Combustion Air Prove Switch S18

S18 is a SPST N.O. switch which monitors combustion air inducer operation. See FIGURE 15 for location. Switch S18 is wired to the A3 ignition control.

The switch closes on a negative pressure fall. This negative pressure fall and switch actuation allows the ignition sequence to continue (proves, by closing, that the combustion air inducer is operating before allowing the gas valve to open.) The combustion air proving switch is factory set and not adjustable. The switch will automatically open on a pressure rise (less negative pressure). S18 closes at 0.25 ± 5 in.w.c. (62.3 ± 12.4 Pa) and opens at 0.10 ± 5 in.w.c. (24.8 ± 12.4Pa)

### 7-Combustion Air Inducer B6

The combustion air inducer provides fresh air to the burner while clearing the combustion chamber of exhaust gases. See FIGURE 15 for the inducer location. The inducer is energized by the A3 ignition control via an on board mounted relay.

The inducer uses a 208/230V single-phase PSC motor and a 4.81in. x 1.25in. (122mm x 32mm) blower wheel. The motor operates at 3200RPM and is equipped with auto-reset overload protection. Blower is supplied by various manufacturers. Ratings may vary by manufacturer. Specific blower electrical ratings can be found on the unit rating plate. Unit with main voltage of 460VAC (G) will use a 460VAC Combustion Air Inducer B6. 240VAC (Y) and 575VAC (J) use a 230V Combustion Air Inducer.

All combustion air blower motors are sealed and cannot be oiled. The blower cannot be adjusted but can be disassembled for cleaning.

### 8-Combustion Air Motor Capacitor C3

Combustion air inducer B6 requires a run capacitor rated at 3 MFD and 370VAC.

### 9-Gas Valves GV1

Gas valve GV1 is a two-stage redundant valve. First stage (low fire) is quick opening (on and off in less than 3 seconds). Second stage is slow opening (on to high fire pressure in 40 seconds and off to low fire pressure in 30 seconds). On a call for first stage heat (low fire), the valve is energized by the ignition control simultaneously with the spark electrode. On a call for second stage heat (high fire), the second stage operator is energized directly from A55.

The valve is adjustable for high fire only. Low fire is not ad-

justable. A manual shut-off knob is provided on the valve for shut-off. The manual shut-off knob immediately closes both stages without delay. FIGURE 23 shows gas valve components. TABLE 9 shows factory gas valve regulation for LGM units.

**TABLE 9**  
**GAS VALVE REGULATION FOR LGM UNITS**

Operating Pressure (outlet) Factory Setting			
Natural		LP	
Low	High	Low	High
1.6±0.2"WC 398±50Pa	3.7±0.3"WC 920±75Pa	5.5±0.3"WC 1368±75Pa	10.5±0.5"WC 2611±7124Pa

**The maximum inlet pressure is 13.0" WC (3232PA)**

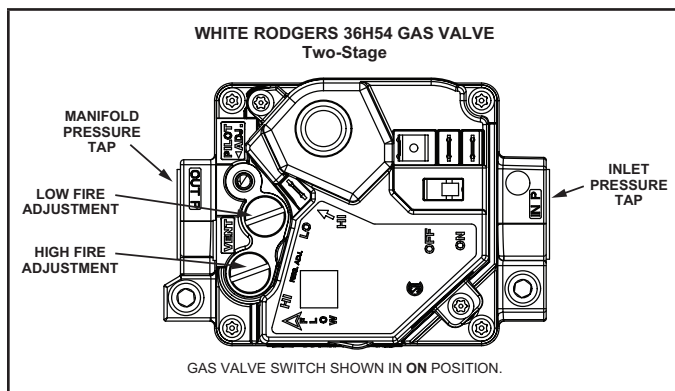

**FIGURE 23**

## 11-Spark Electrodes

An electrode assembly is used for ignition spark. The electrode is mounted through holes on the left-most end of the burner support. The electrode tip protrudes into the flame envelope of the adjacent burner. The electrode assembly is fastened to burner supports and can be removed for service without removing any part of the burners.

During ignition, spark travels through the spark electrode (FIGURE 24) and ignites the left burner. Flame travels from burner to burner until all are lit.

The spark electrode is connected to the ignition control by an 8 mm silicone-insulated stranded high voltage wire. The wire uses 1/4" (6.35 mm) female quick connect on the electrode end and female spark plug-type terminal on the ignition control end.

**NOTE-IN ORDER TO MAXIMIZE SPARK ENERGY TO ELECTRODE, HIGH VOLTAGE WIRE SHOULD TOUCH UNIT CABINET AS LITTLE AS POSSIBLE.**

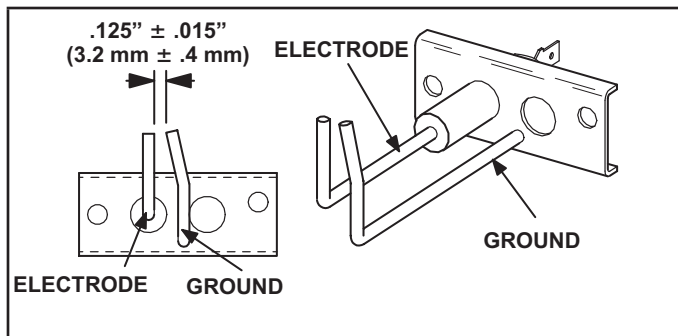

FIGURE 24

## 12-Flame Sensors

A flame sensor is located on the right side of each burner support. See FIGURE 25. The sensor is mounted through a hole in the burner support and the tip protrudes into the flame envelope of the right most burner. The sensor assembly is fastened to burner supports and can be removed for service without removing any part of the burners.

When flame is sensed by the flame sensor (indicated by microamp signal through the flame) sparking stops immediately. During operation, flame is sensed by current passed along the ground electrode (located on the spark electrode), through the flame and into the sensing electrode. The ignition control allows the gas valve to stay open as long as a flame signal (current passed through the flame) is sensed.

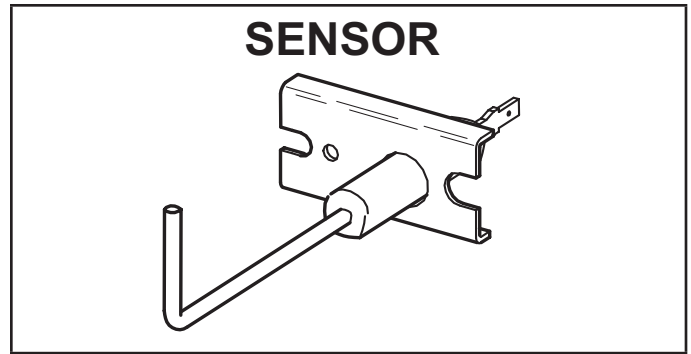

FIGURE 25

## II-PLACEMENT AND INSTALLATION

Make sure the unit is installed in accordance with the installation instructions and all applicable codes. See accessories section for conditions requiring use of the optional roof mounting frame (C1CURB10).

## III-CHARGING

Refrigerant Charge R-454B		
Unit	M <sub>e</sub> (lbs)	M <sub>e</sub> (kg)
092 STG 1	7.3	3.31
092 STG 2	5.1	2.31
102 STG 1	7.3	3.31
102 STG 2	5.1	2.31
120 STG 1	8.22	3.73
120 STG 2	4.59	2.08
150 STG 1	8.1	3.67
150 STG 2	5.78	2.62
092 W/ Humidrol STG 1	8.125	3.69
092 W/ Humidrol STG 2	4.75	2.15
102 W/ Humidrol STG 1	8.125	3.69
102 W/ Humidrol STG 2	4.75	2.15
120 W/ Humidrol STG 1	8.125	3.69
120 W/ Humidrol STG 2	4.75	2.15
150 W/ Humidrol STG 1	8.125	3.69
150 W/ Humidrol STG 2	5.875	2.66

## **! IMPORTANT**

**Units equipped with a Hot Gas Reheat system MUST be charged in standard cooling mode.**

WARNING-Do not exceed nameplate charge under any condition.

This unit is factory charged and should require no further adjustment. If the system requires additional refrigerant, reclaim the charge, evacuate the system, and add required nameplate charge.

Manifold gauge sets used with systems charged with R454B refrigerant must be capable of handling various system operating pressures. The gauges should be rated for use with pressures of 0-800 on the high side and a low side of 30" vacuum to 250 psi with dampened speed to 500 psi. Gauge hoses must be rated for use at up to 800 psi of pressure with a 4000 psi burst rating.

In addition to conventional charging procedures, the following requirements shall be followed.

- Ensure that contamination of different refrigerants does not occur when using charging equipment. Hoses or lines shall be as short as possible to minimize the amount of refrigerant contained in them.
- Cylinders shall be kept in an appropriate position according to the instructions.
- Ensure that the unit is earth grounded prior to charging the system with refrigerant.
- Label the system when charging is complete (if not already).
- Extreme care shall be taken not to overfill the unit.

Prior to recharging the system, it shall be pressure-tested with the appropriate purging gas. The system shall be leak-tested on completion of charging but prior to commissioning. A follow up leak test shall be carried out prior to leaving the site.

- When removing refrigerant from a system, either for servicing or decommissioning, it is recommended good practice that all refrigerants are removed safely.
- When transferring refrigerant into cylinders, ensure that only appropriate refrigerant recovery cylinders are employed. Ensure that the correct number of cylinders for holding the total system charge is available. All cylinders to be used are designated for the recovered refrigerant and labelled for that refrigerant (i. e. special cylinders for the recovery of refrigerant). Cylinders shall be complete with pressure-relief valve and associated shut-off valves in good working order. Empty recovery cylinders are evacuated and, if possible, cooled before recovery
- The recovery equipment shall be in good working order with a set of instructions concerning the equipment that is at hand and shall be suitable for the recovery of all appropriate refrigerants including, when applicable, flammable refrigerants. In addition, a set of calibrated weighing scales shall be available and in good working order. Hoses shall be complete with leak-free disconnect couplings and in good condition. Before using the recovery machine, check that it is in satisfactory working order, has been properly maintained and that any associated electrical components are sealed to prevent ignition in the event of a refrigerant release. Consult manufacturer if in doubt.
- The recovered refrigerant shall be returned to the refrigerant supplier in the correct recovery cylinder, and the relevant waste transfer note arranged. Do not mix refrigerants in recovery units and especially
- If compressors or compressor oils are to be re-

moved, ensure that they have been evacuated to an acceptable level to make certain that flammable refrigerant does not remain within the lubricant. The evacuation process shall be carried out prior to returning the compressor to the suppliers. Only electric heating to the compressor body shall be employed to accelerate this process. When oil is drained from a system, it shall be carried out safely.

**NOTE** - System charging is not recommended below 60°F (15°C). In temperatures below 60°F (15°C), the charge must be weighed into the system.

If weighing facilities are not available, or to check the charge, use the following procedure:

- 1 - Make sure outdoor coil is clean. Attach gauge manifolds and operate unit at full CFM in cooling mode with economizer disabled until system stabilizes using the following mobile service app menu path:

RTU MENU > SERVICE > COMPONENT TEST > COOLING > COOL 4

Make sure all outdoor air dampers are closed.

- 2 - Compare the normal operating pressures to the pressures obtained from the gauges. Check unit components if there are significant differences.
- 3 - Measure the outdoor ambient temperature and the suction pressure. Refer to the charging curve to determine a target liquid temperature.

**NOTE** - Pressures are listed for sea level applications.

- 4 - Use the same thermometer to accurately measure the liquid temperature (in the outdoor section).
  - If measured liquid temperature is higher than the target liquid temperature, add refrigerant to the system.
  - If measured liquid temperature is lower than the target liquid temperature, recover some refrigerant from the system..
- 5 - Add or remove charge in increments. Allow the system to stabilize each time refrigerant is added or removed.
- 6 - Continue the process until measured liquid temperature agrees with the target liquid temperature. Do not go below the target liquid temperature when adjusting charge. Note that suction pressure can change as charge is adjusted.

Example: For the 092U no reheat unit, with a 95°F outdoor ambient and a measured suction pressure of 130psig, the target liquid temperature for Circuit 1 is 96°F. For a measured liquid temperature of 106°F, add charge in increments until measured liquid temperature agrees with the target liquid temperature.

**TABLE 10 581241-01  
LGM092U No Reheat**

	65°F		75°F		85°F		95°F		105°F		115°F	
	Suct (psig)	Disc (psig)	Suct (psig)	Disc (psig)	Suct (psig)	Disc (psig)	Suct (psig)	Disc (psig)	Suct (psig)	Disc (psig)	Suct (psig)	Disc (psig)
<b>Circuit 1</b>	101	219	105	253	108	291	111	335	113	383	114	437
	108	223	112	256	116	295	119	338	122	386	123	440
	122	231	127	264	132	302	136	345	139	393	142	446
	137	241	143	273	148	311	153	354	157	402	160	455
<b>Circuit 2</b>	102	222	105	257	107	297	110	341	113	390	115	443
	110	225	113	260	115	300	118	344	120	393	123	446
	126	231	129	267	131	307	134	352	137	400	140	454
	143	239	146	275	149	315	152	360	155	409	158	462

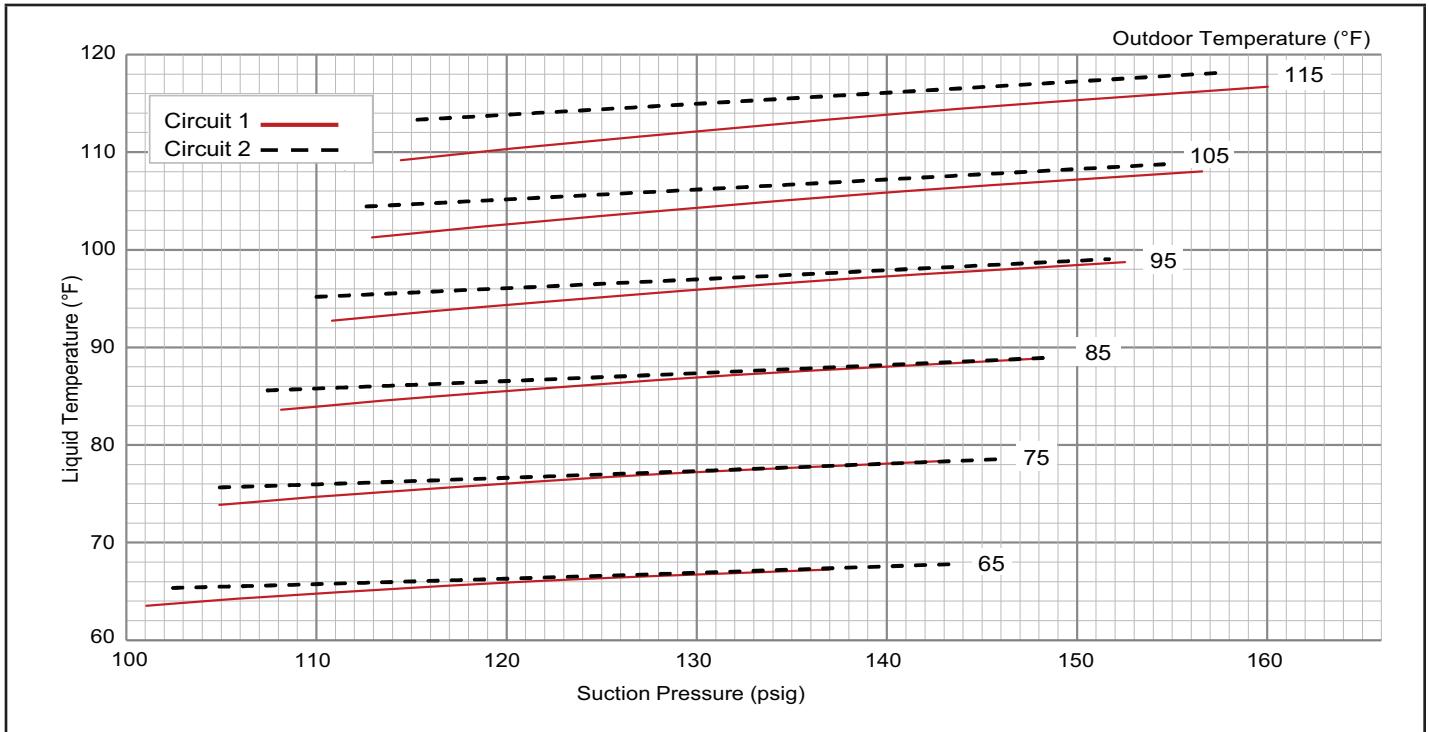

**TABLE 11 581242-01**  
**LGM092U Reheat**

	65°F		75°F		85°F		95°F		105°F		115°F	
	Suct (psig)	Disc (psig)	Suct (psig)	Disc (psig)	Suct (psig)	Disc (psig)	Suct (psig)	Disc (psig)	Suct (psig)	Disc (psig)	Suct (psig)	Disc (psig)
<b>Circuit 1</b>	104	218	105	253	106	292	107	337	109	386	111	440
	112	222	113	256	115	296	116	340	118	389	120	443
	129	228	131	263	133	302	135	346	138	394	141	448
	148	235	150	269	153	308	155	351	159	400	162	453
<b>Circuit 2</b>	100	217	101	250	102	289	104	331	106	379	108	430
	108	220	110	254	111	293	113	336	115	383	118	435
	126	227	128	261	130	300	132	343	134	391	137	443
	145	232	147	267	149	306	151	349	154	397	157	450

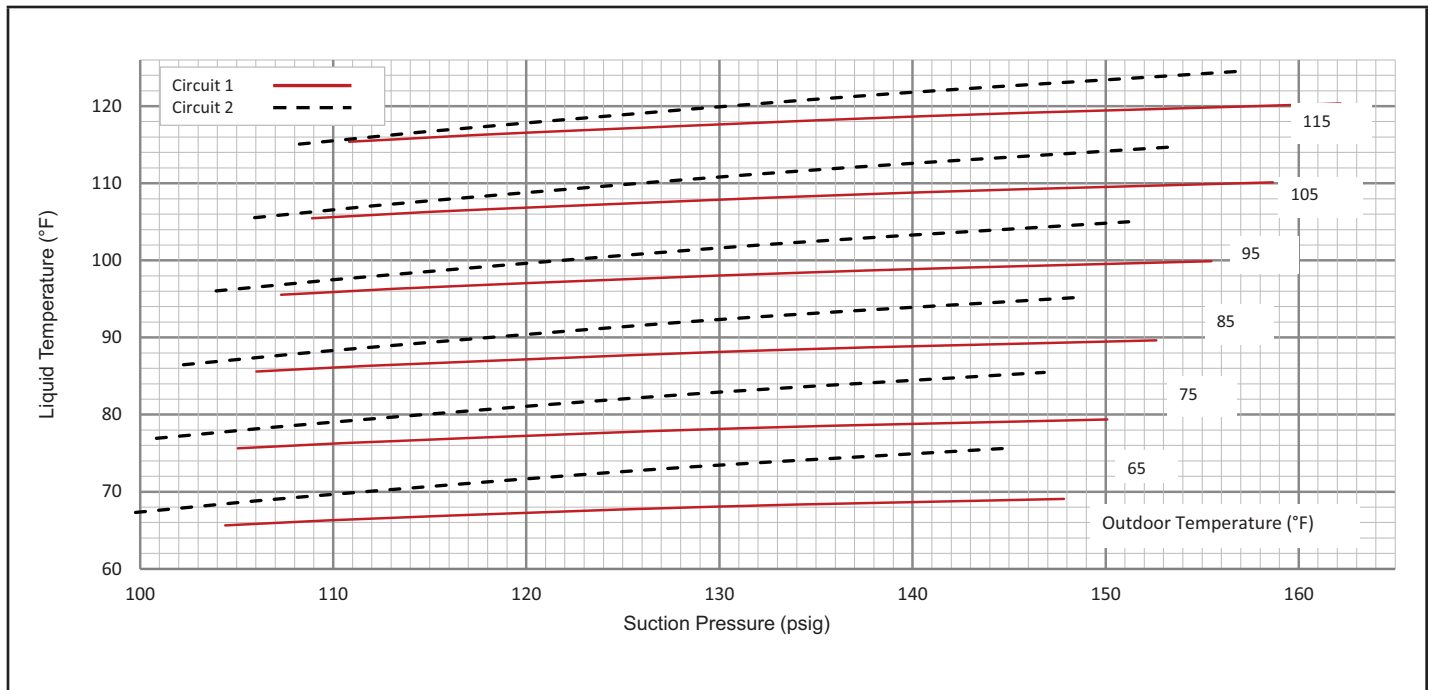

**TABLE 12 581243-01  
LGM102U No Reheat**

	65°F		75°F		85°F		95°F		105°F		115°F	
	Suct (psig)	Disc (psig)	Suct (psig)	Disc (psig)	Suct (psig)	Disc (psig)	Suct (psig)	Disc (psig)	Suct (psig)	Disc (psig)	Suct (psig)	Disc (psig)
<b>Circuit 1</b>	105	224	108	257	111	295	113	338	115	386	116	440
	111	226	115	259	119	297	121	340	124	388	126	441
	126	234	130	266	135	303	139	346	142	394	145	447
	141	244	147	276	152	314	157	356	161	404	165	457
<b>Circuit 2</b>	106	225	108	259	110	298	113	342	116	391	119	444
	113	227	115	262	118	301	121	345	123	393	127	447
	129	234	132	268	134	308	137	352	140	400	143	454
	148	243	150	277	153	317	156	361	159	409	162	463

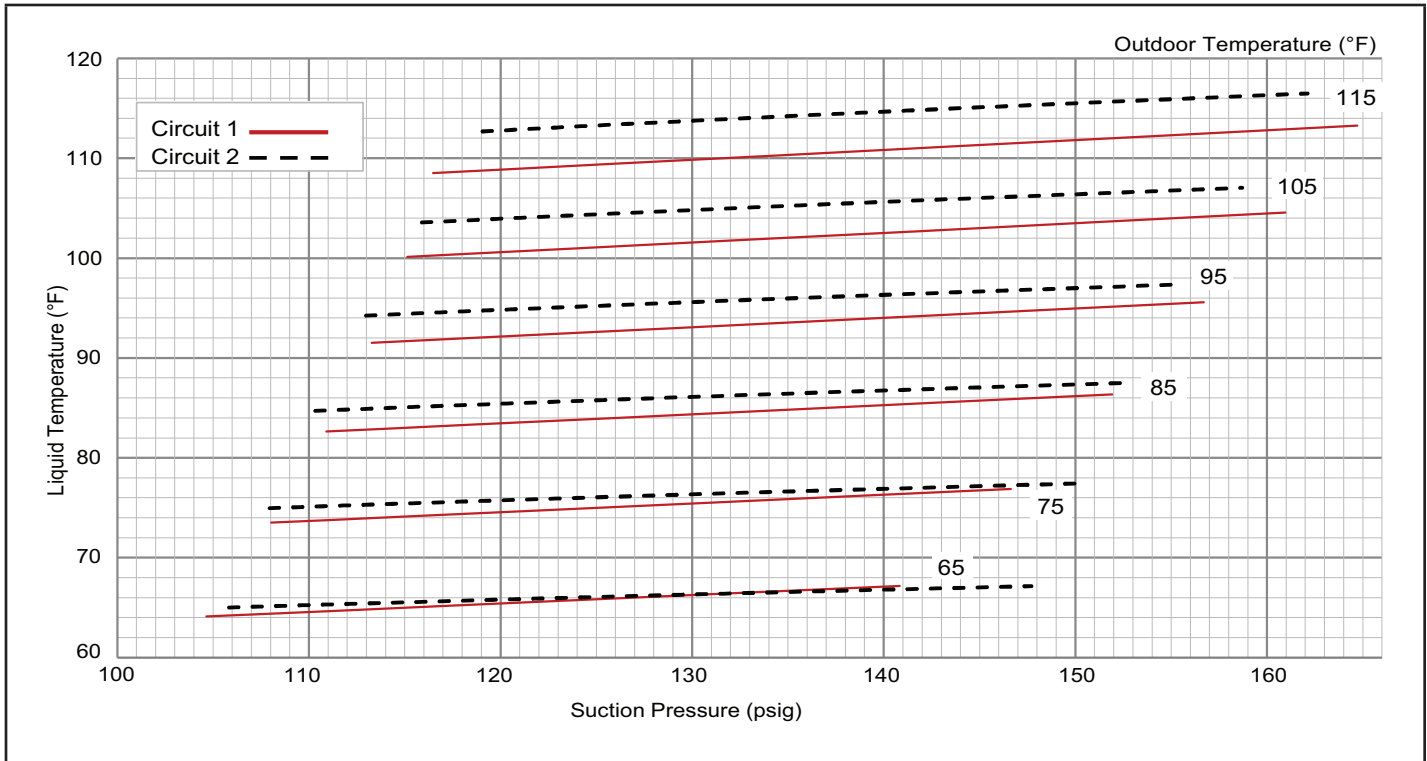

**TABLE 13 581244-01**  
**LGM102U Reheat**

	65°F		75°F		85°F		95°F		105°F		115°F	
	Suct (psig)	Disc (psig)	Suct (psig)	Disc (psig)	Suct (psig)	Disc (psig)	Suct (psig)	Disc (psig)	Suct (psig)	Disc (psig)	Suct (psig)	Disc (psig)
<b>Circuit 1</b>	105	223	107	257	108	296	109	340	111	389	112	443
	113	226	115	259	117	298	118	342	120	390	122	444
	130	233	132	266	134	304	137	347	139	396	142	449
	146	242	149	275	152	312	155	355	159	403	162	456
<b>Circuit 2</b>	104	217	105	251	106	289	107	332	109	380	111	432
	112	220	114	254	115	292	117	336	119	383	121	435
	130	226	131	260	133	299	135	342	138	390	141	442
	147	231	150	266	152	305	155	348	157	396	161	449

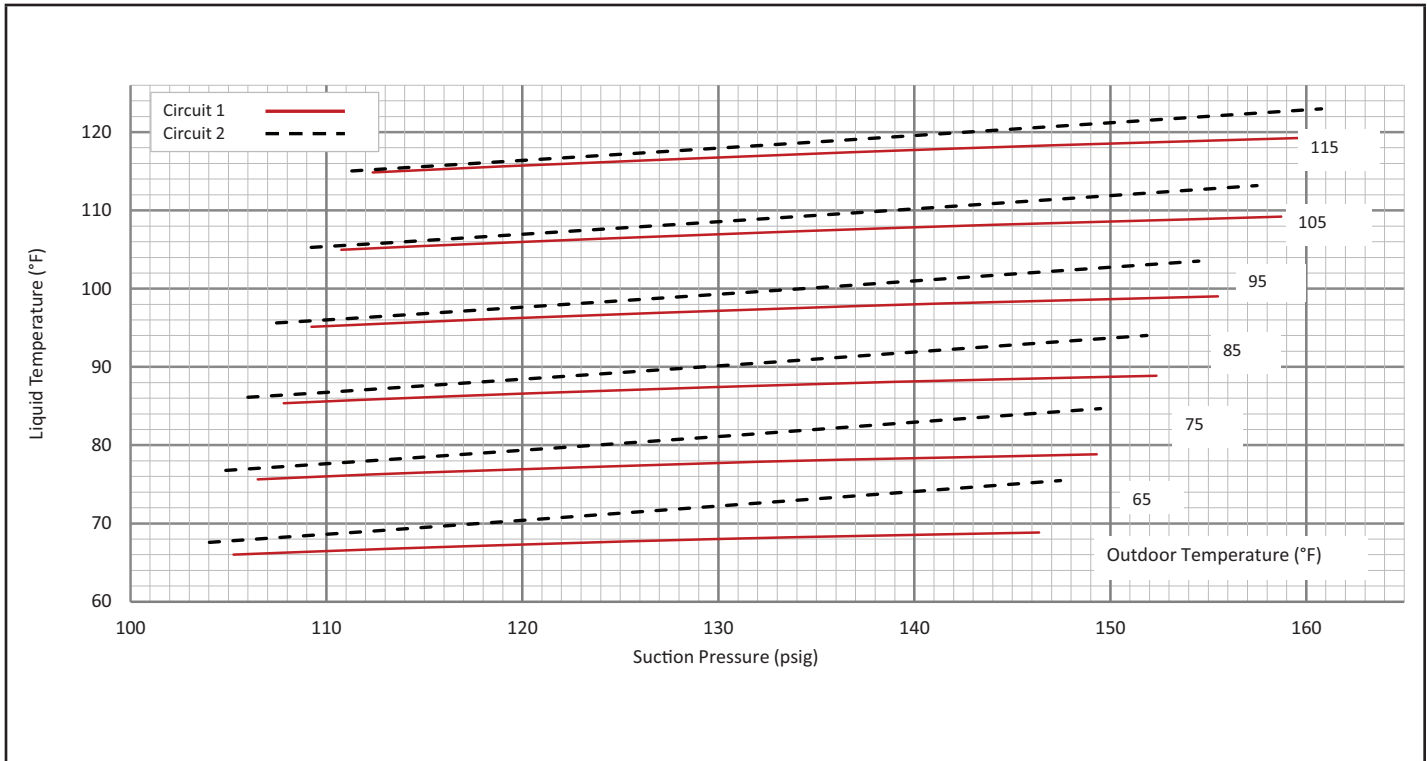

**TABLE 14 581245-01  
LGM120U No Reheat**

	65°F		75°F		85°F		95°F		105°F		115°F	
	Suct (psig)	Disc (psig)	Suct (psig)	Disc (psig)	Suct (psig)	Disc (psig)	Suct (psig)	Disc (psig)	Suct (psig)	Disc (psig)	Suct (psig)	Disc (psig)
<b>Circuit 1</b>	101	230	104	266	107	307	109	353	111	404	113	460
	108	233	111	269	114	310	117	356	119	406	122	462
	123	243	127	278	131	318	134	363	137	413	140	469
	138	256	143	291	148	331	152	375	156	425	160	479
<b>Circuit 2</b>	99	228	101	265	103	306	106	351	108	400	111	453
	107	231	109	268	111	309	114	354	116	403	119	456
	123	239	125	276	128	317	130	362	133	411	136	465
	141	248	143	285	145	326	148	371	151	421	154	474

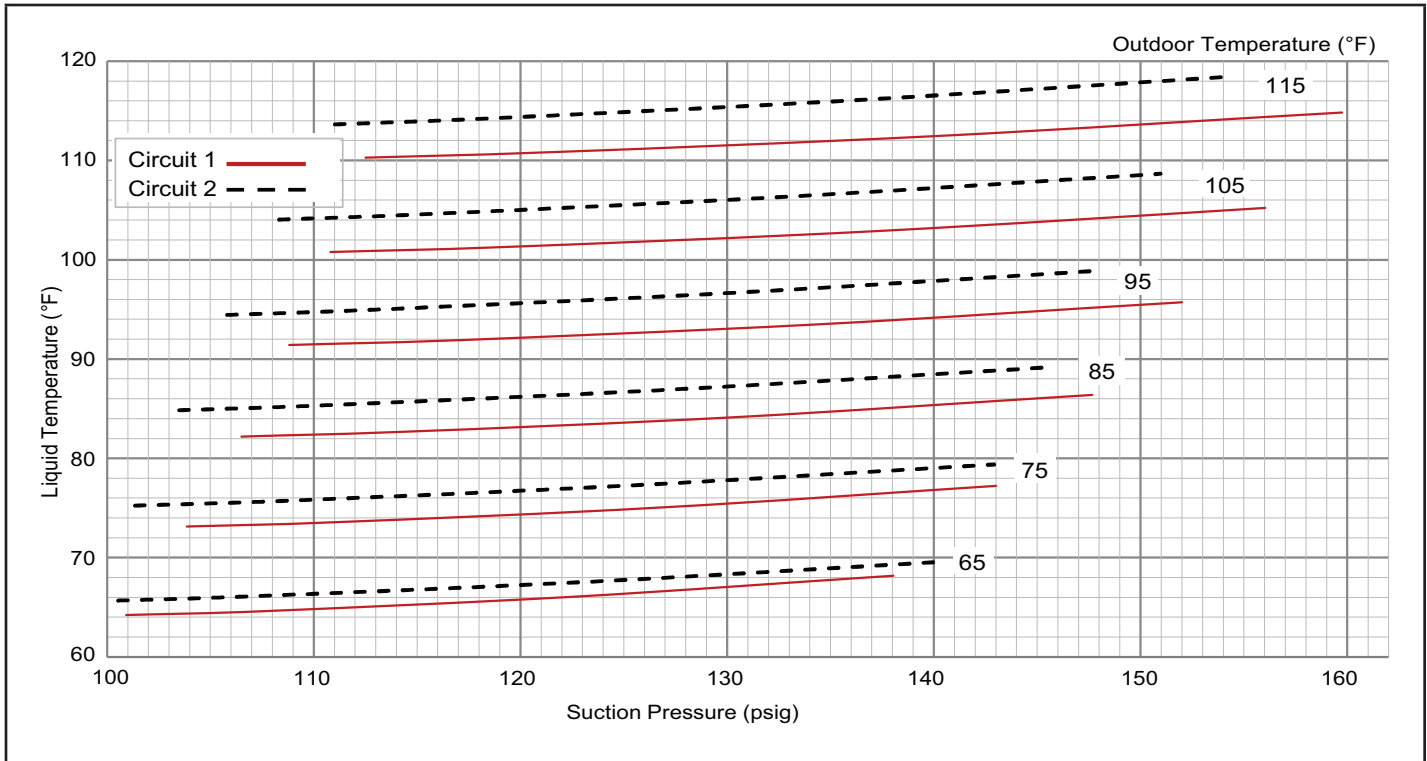

**TABLE 15 581246-01**  
**LGM120U Reheat**

	65°F		75°F		85°F		95°F		105°F		115°F	
	Suct (psig)	Disc (psig)	Suct (psig)	Disc (psig)	Suct (psig)	Disc (psig)	Suct (psig)	Disc (psig)	Suct (psig)	Disc (psig)	Suct (psig)	Disc (psig)
<b>Circuit 1</b>	103	231	103	265	104	304	105	347	107	396	108	449
	110	234	111	268	113	307	114	350	116	398	118	451
	126	242	128	275	130	314	133	357	135	405	139	458
	141	251	144	284	148	322	151	365	155	413	159	466
<b>Circuit 2</b>	98	226	99	259	101	297	102	339	104	387	106	439
	106	229	107	263	109	301	111	343	113	391	115	443
	123	236	124	269	126	308	129	351	131	399	134	452
	140	241	142	276	145	315	147	358	150	407	153	460

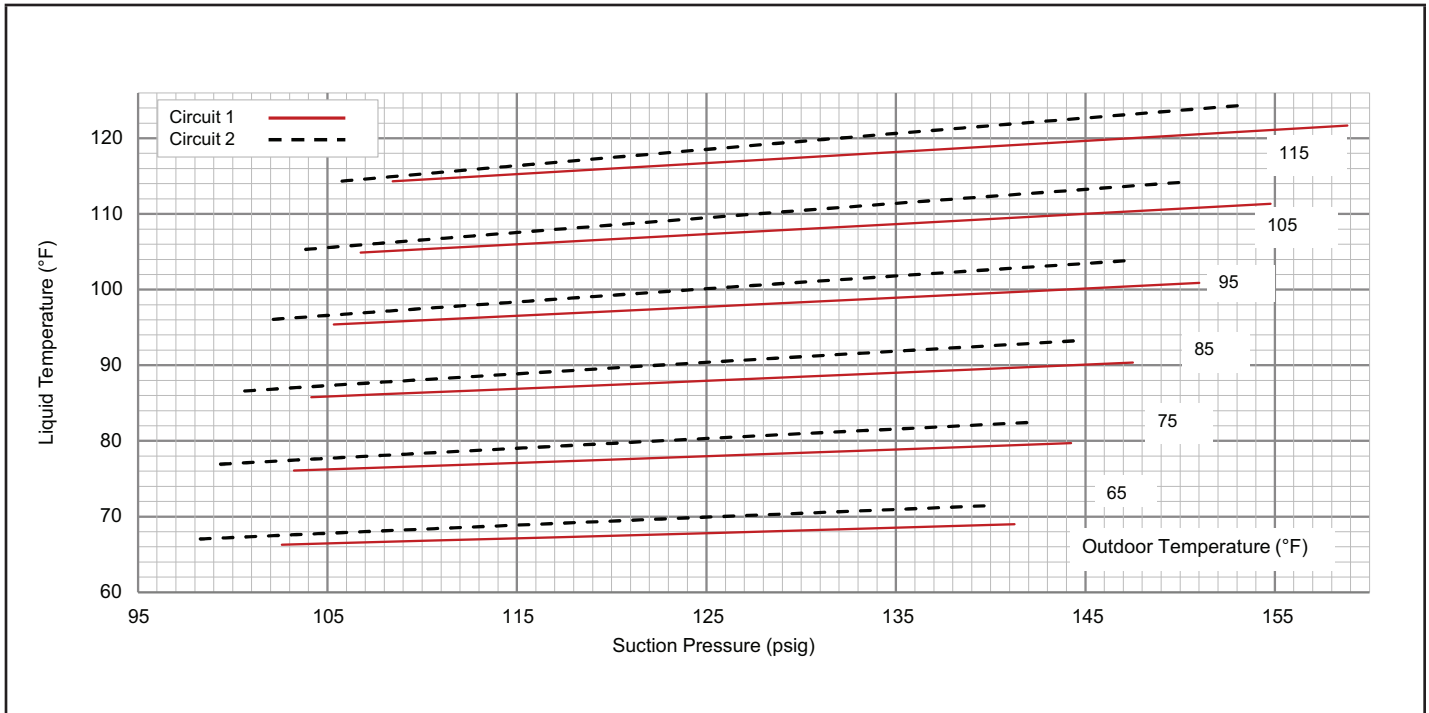

**TABLE 16 581247-01  
LGM150U No Reheat**

	65°F		75°F		85°F		95°F		105°F		115°F	
	Suct (psig)	Disc (psig)	Suct (psig)	Disc (psig)	Suct (psig)	Disc (psig)	Suct (psig)	Disc (psig)	Suct (psig)	Disc (psig)	Suct (psig)	Disc (psig)
<b>Circuit 1</b>	99	244	102	284	104	328	106	374	108	425	110	479
	106	248	109	288	111	331	114	377	116	428	119	481
	120	257	123	296	127	339	130	385	133	435	136	488
	135	267	139	306	143	349	148	395	152	444	155	497
<b>Circuit 2</b>	94	250	96	291	98	337	100	389	102	445	105	506
	101	254	103	294	105	340	107	391	110	447	113	507
	115	263	117	303	120	347	122	397	125	452	129	512
	131	273	133	312	136	356	139	405	142	459	146	518

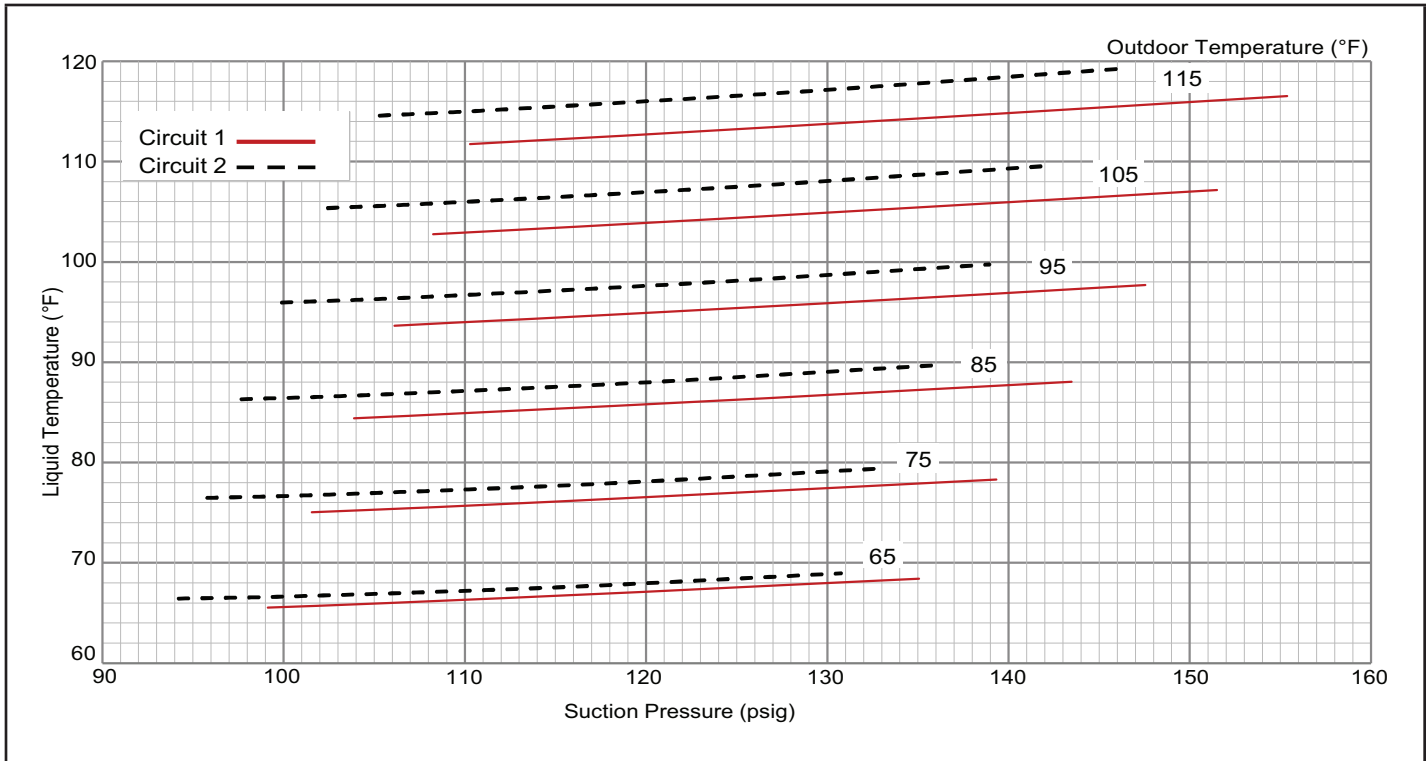

**TABLE 17 581248-01  
LGM150U Reheat**

	65°F		75°F		85°F		95°F		105°F		115°F	
	Suct (psig)	Disc (psig)	Suct (psig)	Disc (psig)	Suct (psig)	Disc (psig)	Suct (psig)	Disc (psig)	Suct (psig)	Disc (psig)	Suct (psig)	Disc (psig)
<b>Circuit 1</b>	100	253	102	296	104	344	106	399	108	460	111	526
	108	252	110	293	112	340	115	393	117	452	120	516
	124	260	126	297	129	340	133	389	136	444	140	505
	141	278	144	312	148	351	152	397	156	448	160	505
<b>Circuit 2</b>	92	250	94	290	96	337	98	392	101	455	103	524
	100	254	102	293	104	340	106	394	109	456	111	524
	115	264	117	301	120	346	122	398	125	458	128	525
	130	274	133	310	136	353	139	403	142	461	145	526

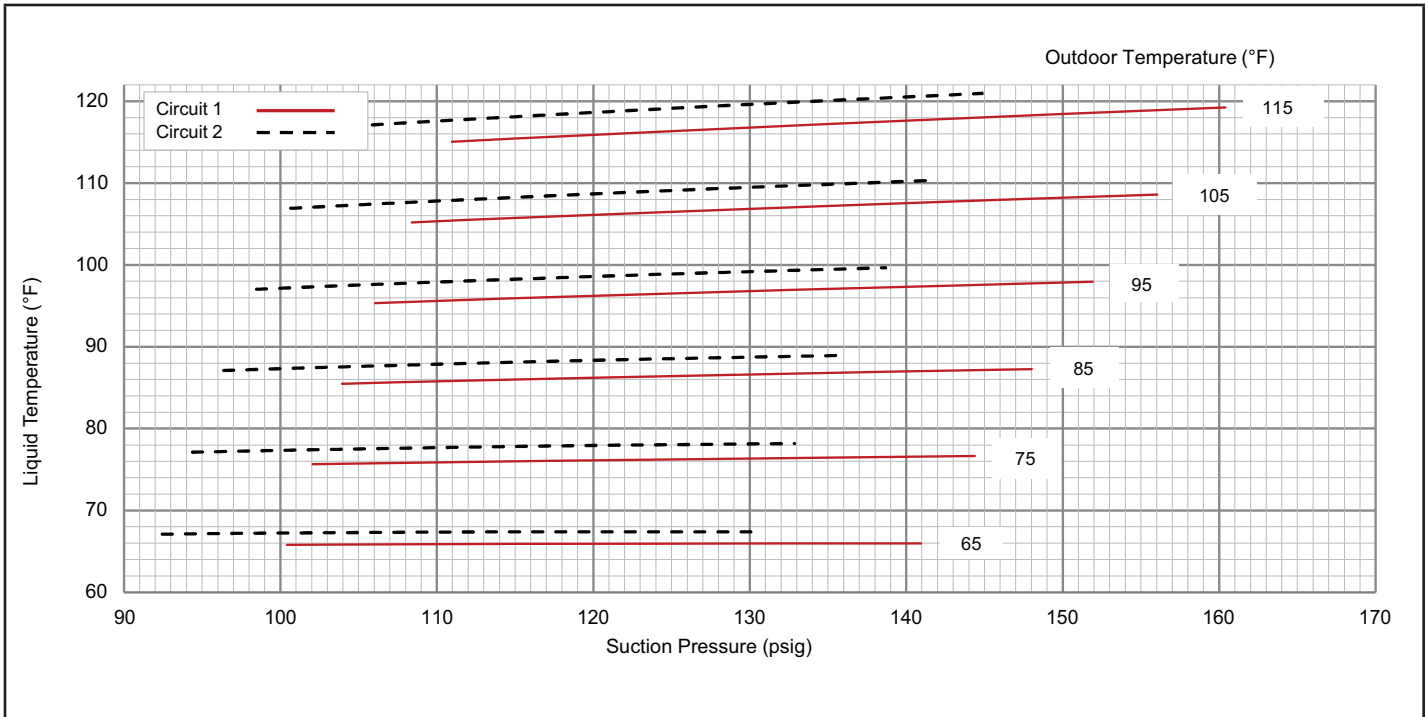

## IV-START-UP - OPERATION

Refer to start-up directions and to the unit wiring diagram when servicing. See unit nameplate for minimum circuit ampacity and maximum fuse size.

### A-Preliminary and Seasonal Checks

- 1 - Make sure the unit is installed in accordance with the installation instructions and applicable codes.
- 2 - Inspect all electrical wiring, both field and factory installed for loose connections. Tighten as required. Refer to unit diagram located on inside of unit control box cover.
- 3 - Check to ensure that refrigerant lines are in good condition and do not rub against the cabinet or other refrigerant lines.
- 4 - Check voltage. Voltage must be within the range listed on the nameplate. If not, consult power company and have the voltage corrected before starting the unit.
- 5 - Recheck voltage and amp draw with unit running. If voltage is not within range listed on unit nameplate, stop unit and consult power company. Refer to unit nameplate for maximum rated load amps.
- 6 - Inspect and adjust blower belt (see section on Blower Compartment - Blower Belt Adjustment).

### B-Cooling Start-up See FIGURE 26

**NOTE**-Crankcase heaters must be energized 24 hours before attempting to start compressor. Set thermostat so that there is no demand to prevent compressor from cycling. Apply power to unit.

VFD Units - Refer to the Supply Air Inverter Start-Up section.

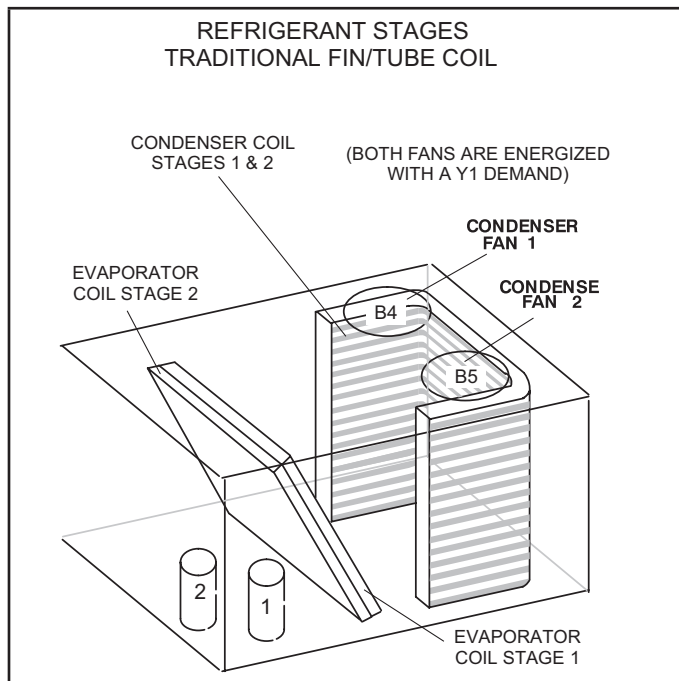

FIGURE 26

- 1 - Initiate full load cooling operation using the following mobile service app menu path:

**RTU MENU > SERVICE > COMPONENT TEST > COOLING > COOL 4**

- 2 - Refer to Cooling Operation section for cooling start-up.
- 3 - Units have two refrigerant circuits. See FIGURE 26.
- 4 - Each refrigerant circuit is charged with R454B refrigerant. See unit rating plate for correct amount of charge.
- 5 - Refer to Refrigerant Charge and Check section for proper method to check refrigerant charge.

### C-Heating Start-up

#### FOR YOUR SAFETY READ BEFORE LIGHTING

<b>⚠ WARNING</b>	
	<b>Danger of explosion. Can cause injury or product or property damage. If overheating occurs or if gas supply fails to shut off, shut off the manual gas valve to the appliance before shutting off electrical supply.</b>

<b>⚠ WARNING</b>	
	<b>Electric shock hazard. Can cause injury or death. Before attempting to perform any service or maintenance, turn the electrical power to unit OFF at disconnect switch(es). Unit may have multiple power supplies.</b>

**BEFORE LIGHTING** smell all around the appliance area for gas. Be sure to smell next to the floor because some gas is heavier than air and will settle on the floor.

Use only your hand to push in or turn the gas control knob. Never use tools. If the knob will not push in or turn by hand, do not try to repair it, call a qualified service technician. Force or attempted repair may result in a fire or explosion.

In case of a safety shutdown, move thermostat switch to OFF and return the thermostat switch to HEAT to reset ignition control.

#### Placing Furnace In Operation (FIGURE 27)

- 1 - Set thermostat to lowest setting.
- 2 - Turn off all electrical power to appliance.
- 3 - This appliance is equipped with an ignition device which automatically lights the burner. Do not try to light the burner by hand.
- 4 - Open or remove the heat section access panel.

- 5 - Turn gas valve switch to “**OFF**”. Do not force.
- 6 - Wait five (5) minutes to clear out any gas. If you then smell gas, **STOP!** Immediately call your gas supplier from a neighbor’s phone. Follow the gas supplier’s instructions. If you do not smell gas, go to the next step.
- 7 - Turn gas valve switch to “**ON**”. Do not force.
- 8 - Close or replace the heat section access panel.
- 9 - Turn on all electrical power to appliance.
- 10 - Set thermostat to desired setting.
- 11 - The combustion air inducer will start. The burners will light within 40 seconds.
- 12 - If the appliance does not light the first time (gas line not fully purged), it will attempt up to two more ignitions before locking out.
- 13 - If lockout occurs, repeat steps 1 through 10.
- 14 - If the appliance will not operate, follow the instructions “Turning Off Gas to Appliance” and call your service technician or gas supplier.

**Turning Off Gas to Appliance**

- 1 - If using an electromechanical thermostat, set to the lowest setting.
- 2 - Before performing any service, turn off all electrical power to the appliance.
- 3 - Open or remove the heat section access panel.
- 4 - Turn gas valve switch to “**OFF**”. Do not force.

**D-Safety or Emergency Shutdown**

Turn off power to the unit. Close manual and main gas valves.

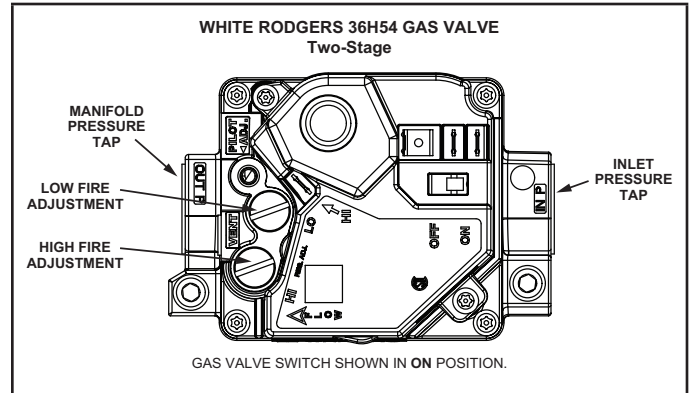

**FIGURE 27**

## V- SYSTEMS SERVICE CHECKS

**⚠ WARNING**



**Electric shock hazard. Can cause injury or death. Before attempting to perform any service or maintenance, turn the electrical power to unit OFF at disconnect switch(es). Unit may have multiple power supplies.**

### A-Heating System Service Checks

All LGM units are ETL/CSA design certified without modification. Before checking piping, check with gas company or authorities having jurisdiction for local code requirements. Refer to the LGM installation instruction for more information.

#### 1-Gas Piping

Gas supply piping must not allow more than 0.5"W.C. (124.3 Pa) drop in pressure between the gas meter and the unit. Supply gas pipe must not be smaller than the unit gas connection. Refer to installation instructions for details.

#### 2-Testing Gas Piping

**NOTE-***In case emergency shutdown is required, turn off the main manual shut-off valve and disconnect the main power to the unit. These controls should be properly labeled by the installer.*

When pressure testing gas lines, the gas valve must be disconnected and isolated. **Gas valves can be damaged if subjected to more than 0.5 psig [14"W.C. (3481 Pa)].** See FIGURE 28.

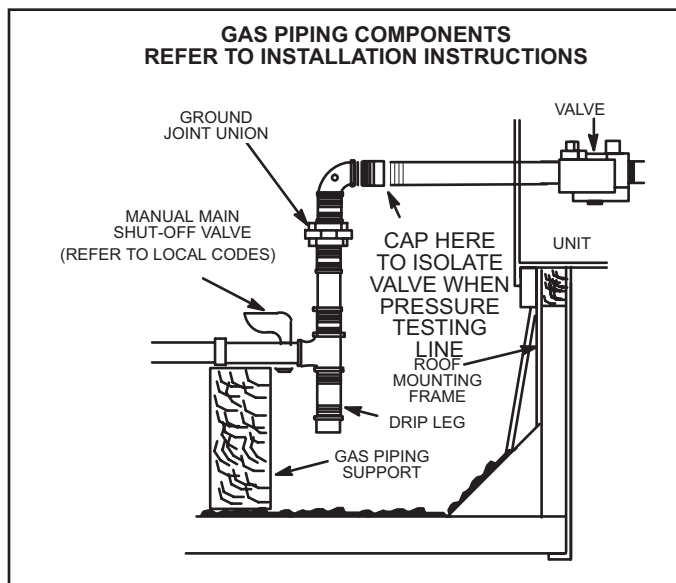

FIGURE 28

When checking piping connection for gas leaks, use the preferred means. Common kitchen detergents can cause harmful corrosion on various metals used in gas piping.

The use of specialty Gas Leak Detector is strongly recommended.

**Do not use matches, candles, flame or any other source of ignition to check for gas leaks.**

#### 3-Testing Gas Supply Pressure

When testing gas supply pressure, connect test gauge to the inlet pressure tap located on unit gas valve GV1. Test supply gas pressure with unit firing at maximum rate (both stages energized). Make sure the reading falls within the range of the following values. Low pressure may result in erratic operation or "underfire." High pressure can result in permanent damage to the gas valve or "overfire." For natural gas units, operating pressure at the unit gas connection must be between 4.7"W.C. and 10.5"W.C. (1168 Pa and 2610 Pa). For L.P. gas units, operating pressure at the unit gas connection must be between 10.8"W.C. and 13.5"W.C. (2685.3 Pa and 3356.7 Pa).

On multiple unit installations, each unit should be checked separately while operating at maximum rate, beginning with the one closest to the supply gas main and progressing to the one furthest from the main. Multiple units should also be tested with and without the other units operating. Supply pressure must fall within the range listed in the previous paragraph.

#### 4-Check and Adjust Manifold Pressure

After line pressure has been checked and adjusted, check manifold pressure. Move test gauge to the outlet pressure tap located on unit gas valve GV1. See FIGURE 27 for location of pressure tap on the gas valve.

The manifold pressure is factory set and should not require adjustment. If manifold pressure is incorrect and no other source of improper manifold pressure can be found, the valve must be replaced. See FIGURE 27 for location of gas valve (manifold pressure) adjustment screw.

All gas valves are factory regulated. The gas valve should completely and immediately cycle off in the event of gas or power failure. The manual shut-off knob can be used to immediately shut off gas supply.

**⚠ CAUTION**

**For safety, connect a shut-off valve between the manometer and the gas tap to permit shut off of gas pressure to the manometer.**

## Manifold Adjustment Procedure

- 1 - Connect test gauge to the outlet pressure tap on the gas valve. Start the unit (call for second stage heat) and allow five minutes for the unit to reach steady state.
- 2 - While waiting for the unit to stabilize, notice the flame. The flame should be stable without flashback and should not lift from the burner heads. Natural gas should burn basically blue with some clear streaks. L.P. gas should burn mostly blue with some clear yellow streaks.
- 3 - After allowing the unit to stabilize for five minutes, record the manifold pressure and compare to the values given in TABLE 9.



## IMPORTANT

Disconnect heating demand as soon as an accurate reading has been obtained.

### 5-Proper Gas Flow

To check for proper gas flow to burners, determine Btuh input from unit rating plate or the gas heating capacity in the SPECIFICATIONS tables. Divide this input rating by the Btuh per cubic foot of available gas. Result is the number of cubic feet per hour required. Determine the flow of gas through gas meter for two minutes and multiply by 30 to get hourly flow of gas to the burners.

**NOTE** - To obtain accurate reading, shut off all other gas appliances connected to meter.

### 6-Inshot Burner

Burners are factory set for maximum air and cannot be adjusted. Always operate unit with access panel in place. A peep hole is furnished in the heating access panel for flame viewing. Natural gas should burn basically blue with some clear streaks. L.P. gas should burn mostly blue with some clear yellow streaks.

FIGURE 29 shows how to remove burner assembly.

- 1 - Turn off power to unit and shut off gas supply.
- 2 - Remove screws holding the burner support cap.
- 3 - Slide each burner off its orifice.
- 4 - Clean and reassemble (reverse steps 1-3).
- 5 - Be sure to secure all wires and check plumbing.
- 6 - Turn on power to unit. Follow lighting instructions attached to unit and operate unit in heating mode. Check burner flames. They should be blue with yellow streaks.

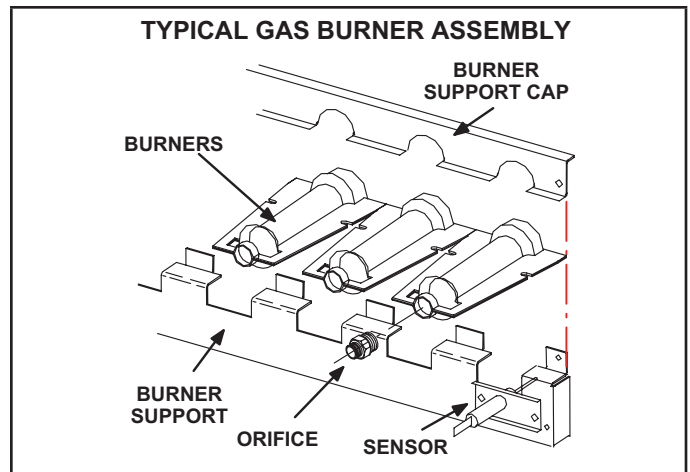

FIGURE 29

### 7-Spark Electrode Gap

The spark electrode assembly can be removed for inspection by removing two screws securing the electrode assembly and sliding it out of unit.

For proper unit operation, electrodes must be positioned and the spark gap set correctly.

Spark gap may be checked with appropriately sized twist drills or feeler gauges. Disconnect power to the unit and remove electrode assembly. The gap should be between  $0.125" \pm 0.015"$  ( $3.2 \text{ mm} \pm .4 \text{ mm}$ ). See FIGURE 24.

### 8-Heat Exchanger

To Access or Remove Heat Exchanger From Unit:

- 1 - Turn off gas and electric power.
- 2 - Remove access panel(s) and unit center mullion.
- 3 - Remove gas valve, manifold assembly and burners.
- 4 - Remove combustion air inducer and flue box. Pay careful attention to the order in which gaskets and orifice are removed.
- 5 - Support heat exchanger (to prevent it from falling when final screws are removed.)
- 6 - Remove screws supporting heat exchanger.
- 7 - To install heat exchanger, reverse procedure. Be sure to secure all wires and check plumbing and burner plate for airtight seal. Screws must be torqued to 35 in.- lbs. to ensure proper operation.

### 9-Flame Sensing

Flame current is an electrical current which passes from the ignition control through the sensor electrode during unit operation.

The current passes from the sensor through the flame to the ground electrode (located on the flame electrode) to complete a safety circuit. The electrodes should be located so the tips are at least  $1/2"$  ( $12.7 \text{ mm}$ ) inside the flame envelope. Do not bend electrodes. To measure flame current, follow the procedure on the following page:

**NOTE**-Electrodes are not field adjustable. Any alterations to the electrode may create a hazardous condition that can cause property or personal injury.

- 1 - Disconnect power to unit.
- 2 - Remove lead from sensing electrode and install a 0-50DC microamp meter in series between the sensing electrode and the sensing lead.
- 3 - Reconnect power and adjust thermostat for heating demand.
- 4 - When flame is established, compare reading to TABLE 18. Do not bend electrodes.
- 5 - Disconnect power to unit before disconnecting meter. Make sure sensor wire is securely reconnected before reconnecting power to unit.

**TABLE 18**

Manufacturer	Nominal Signal Microamps	Drop Out
JOHNSON	0.5 - 1.0	.09

*NOTE-If the meter scale reads 0, the leads are reversed. Disconnect power and reconnect leads for proper polarity.*

### 10-Combustion Air Inducer

The combustion air inducer is factory set and is not field adjustable. However, operation should be monitored to ensure proper operation. The combustion air inducer is used to draw fresh air into the combustion chamber while simultaneously expelling exhaust gases. The inducer operates throughout the heating cycle.

On a heating demand, the ignition control is energized by the A55 Unit Controller. The ignition control then allows 30 to 40 seconds for the combustion air inducer to vent exhaust gases from the burners. When the combustion air inducer is purging the exhaust gases, the combustion air proving switch closes, proving that the combustion air inducer is operating before allowing the ignition control to energize.

When the combustion air prove switch is closed and the delay is over, the ignition control activates the first stage operator of the gas valve (low fire), the spark and the flame sensing electrode. Sparking stops immediately after flame is sensed.

### B-Cooling System Service Checks

LGM units are factory charged and require no further adjustment; however, charge should be checked periodically. See section III- CHARGING.

### VI-MAINTENANCE

The unit should be inspected once a year by a qualified service technician.

**WARNING**



Electric shock hazard. Can cause injury or death. Before attempting to perform any service or maintenance, turn the electrical power to unit OFF at disconnect switch(es). Unit may have multiple power supplies.

**IMPORTANT**

**Label all wires prior to disconnection when servicing controls. Wiring errors can cause improper and dangerous operation. Verify proper operation after servicing.**

**WARNING**

**Any service personnel installing, decommissioning, or performing maintenance on the unit must be properly trained with A2L refrigerants**

### Prior to beginning work on systems containing refrigerant to ensure the risk of ignition is minimized:

- All work shall be undertaken under a controlled procedure so as to minimize the risk of a flammable gas or vapor being present while the work is being performed.
- The area shall be checked with an appropriate refrigerant detector prior to and during work, to ensure the technician is aware of potentially toxic or flammable atmospheres. Ensure that the leak detection equipment being used is suitable for use with all applicable refrigerants, i. e. non-sparking, adequately sealed or intrinsically safe.
- If any hot work is to be conducted on the refrigerating equipment or any associated parts, the appropriate fire extinguishing equipment shall be available to hand. Have a dry powder or CO2 fire extinguisher adjacent to the charging area.
- No person carrying out work in relation to a refrigerating system which involves exposing any pipe work shall use any sources of ignition in such a manner that it may lead to the risk of fire or explosion. All possible ignition sources, including cigarette smoking, should be kept sufficiently far away from the site of installation, repairing, removing and disposal, during which refrigerant can possibly be released to the surrounding space. Prior to work taking place, the area around the equipment is to be surveyed to make sure that there are no flammable hazards or ignition risks. "No Smoking" signs shall be displayed.
- Ensure that the area is in the open or that it is adequately ventilated before breaking into the system or conducting any hot work.
- A degree of ventilation shall continue during the period that the work is carried out. The ventilation should safely disperse any released refrigerant and preferably expel it externally into the atmosphere.
- Where electrical components are being changed, service technicians shall be fit for the purpose and to the correct specification. At all times the manufacturer's maintenance and service guidelines shall be followed. If in doubt, consult the manufacturer's

technical department for assistance. The following checks shall be applied to installations using flammable refrigerants as applicable:

- 1 - The actual refrigerant charge is in accordance with the room size within which the refrigerant containing parts are installed.
  - 2 - The ventilation machinery and outlets are operating adequately and are not obstructed.
  - 3 - If an indirect refrigerating circuit is being used, the secondary circuit shall be checked for the presence of refrigerant.
  - 4 - Markings on the equipment should be visible and legible. Markings and signs that are illegible shall be corrected.
  - 5 - Refrigerating pipes or components are installed in a position where they are unlikely to be exposed to any substance which may corrode refrigerant containing components, unless the components are constructed of materials which are inherently resistant to being corroded or are suitably protected against being so corroded.
- For systems containing refrigerant all repair and maintenance to electrical components shall include initial safety checks and component inspection procedures such that capacitors are discharged in a safe manner to avoid the possibility of sparking, that no live electrical components and wiring are exposed while charging, recovering, or purging the system, and that there is continuity of earth bonding. If a fault exists that could compromise safety, then no electrical supply shall be connected to the circuit until it is satisfactorily dealt with. If the fault cannot be corrected immediately but it is necessary to continue operation, an adequate temporary solution shall be used that is reported to the owner of the equipment, so all parties are advised.

**NOTE** - Sealed electrical components shall be replaced, not repaired.

**NOTE** - Intrinsically safe components must be replaced, not repaired.

- Under no circumstances shall potential sources of ignition be used in the searching for or detection of refrigerant leaks. A halide torch (or any other detector using a naked flame) shall not be used. Electronic leak detectors may be used to detect refrigerant leaks but, in the case of flammable refrigerants, the sensitivity may not be adequate, or may need re-calibration. (Detection equipment shall be calibrated in a refrigerant-free area.) Ensure that the detector is not a potential source of ignition and is suitable for the refrigerant used. Leak detection equipment shall be set at a percentage of the LFL of the refrigerant and shall be calibrated to the refrigerant employed, and the appropriate percentage of gas (25 % maximum) is confirmed.

- Leak detection fluids are also suitable for use with most refrigerants but the use of detergents containing chlorine shall be avoided as the chlorine may react with the refrigerant and corrode the copper pipe-work. If a leak is suspected, all naked flames shall be removed/extinguished. If a leakage of refrigerant is found which requires brazing, all of the refrigerant shall be recovered from the system, or isolated (by means of shut-off valves) in a part of the system remote from the leak.
- When breaking into the refrigerant circuit to make repairs – or for any other purpose – conventional procedures shall be used. However, for flammable refrigerants it is important that best practice be followed, since flammability is a consideration. The following procedure shall be adhered to:
  - a. Safely remove refrigerant following local and national regulations,
  - b. Evacuate the circuit,
  - c. Purge the circuit with inert gas,
  - d. Evacuate,
  - e. Purge with inert gas,
  - f. Open the circuit.
- The refrigerant charge shall be recovered into the correct recovery cylinders if venting is not allowed by local and national codes. For appliances containing flammable refrigerants, the system shall be purged with oxygen-free nitrogen to render the appliance safe for flammable refrigerants. This process might need to be repeated several times. Compressed air or oxygen shall not be used for purging refrigerant systems. Refrigerant purging shall be achieved by breaking the vacuum in the system with oxygen-free nitrogen and continuing to fill until the working pressure is achieved, then venting to atmosphere, and finally pulling down to a vacuum. This process shall be repeated until no refrigerant is within the system. When the final oxygen-free nitrogen charge is used, the system shall be vented down to atmospheric pressure to enable work to take place. Ensure that the outlet for the vacuum pump is not close to any potential ignition sources and that ventilation is available.

## A-Filters

LGM units use four 20 x 25 x 2" pleated throw-away type filters. Filters may be accessed through the economizer / filter access door. Filters should be checked monthly (or more frequently in severe use) and cleaned or replaced regularly. Take note of the "AIR FLOW DIRECTION" marking on the filter frame when re-installing.

**NOTE-***Filters must be U.L.C. certified or equivalent for use in Canada.*

## B-Lubrication

All motors and blower wheels used in LGM units are pre-lubricated; no further lubrication is required.

## C-Supply Air Blower Wheel

Annually inspect supply air blower wheel for accumulated dirt or dust. Turn off power before attempting to remove access panel or to clean blower wheel.

## D-Evaporator Coil

Inspect and clean coil at beginning of each season. Clean using mild detergent or commercial coil cleanser. Check condensate drain pan and line, if necessary. Flush coil and condensate drain with water taking care not to get insulation, filters and return air ducts wet. Check connecting lines and coil for evidence of oil and refrigerant leaks.

## E-Condenser Coil

Clean condenser coil annually with water and inspect monthly during the cooling season. Clean the all-aluminum coil by spraying the coil steadily and uniformly from top to bottom. Do not exceed 900 psi or a 45 angle; nozzle must be at least 12 inches from the coil face. Take care not to fracture the braze between the fins and refrigerant tubes. Reduce pressure and work cautiously to prevent damage.

**NOTE-***If owner complains of insufficient cooling, the unit should be gauged and refrigerant charge checked. Refer to Gauge Manifold Attachment and Charging sections in this manual.*

## F-Electrical

- 1 - Check all wiring for loose connections.
- 2 - Check for correct voltage at unit (unit operating).
- 3 - Check amp-draw on both condenser fan motor and blower motor.

Fan Motor Rating Plate \_\_\_\_ Actual \_\_\_\_\_

Indoor Blower Motor Rating Plate \_\_\_\_ Actual \_\_\_\_\_

- 4 - Check crankcase heater temperatures to ensure they are operating.
- 5 - Check compressor sump thermistors to ensure they are making contact with compressor shell (ultra high efficiency units only).

## VII-ACCESSORIES

The accessories section describes the application of most of the optional accessories which can be factory or field installed to the LGM units.

### A-Mounting Frames

When installing units on a combustible surface for down-flow discharge applications, a C1CURB roof mounting frame is used. The roof mounting frames are recommended in all other applications but not required. If the LGM units are not mounted on a flat (roof) surface, they MUST be supported under all edges and under the middle of the unit to prevent sagging. The units MUST be mounted level within 1/16" per linear foot or 5mm per meter in any direction.

The assembled C1CURB mounting frame is shown in FIGURE 30. Refer to the roof mounting frame installation instructions for details of proper assembly and mounting. The roof mounting frame MUST be squared to the roof and level before mounting. Plenum system MUST be installed before the unit is set on the mounting frame. Typical roof curbing and flashing is shown in FIGURE 31. Refer to the roof mounting frame installation instructions for proper plenum construction and attachment.

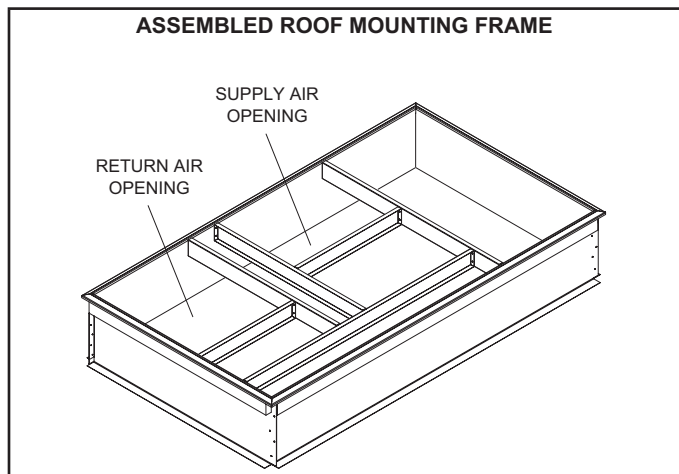

FIGURE 30

### B-LP / Propane Kit

Natural to LP /propane kit includes a spring kit and three stickers. In addition, the LP kit contains either six, nine, or eleven burner orifices. For more detail refer to the natural to LP gas change over kit installation instructions.

### C-Dirty Filter Switch S27

The dirty filter switch senses static pressure increase indicating a dirty filter condition. The switch is N.O. and closes at 1" W.C. (248.6 Pa) The switch is mounted on the top filter channel corner. Wiring for the dirty filter switch is shown on the temperature control section (C2) wiring diagram in back of this manual.

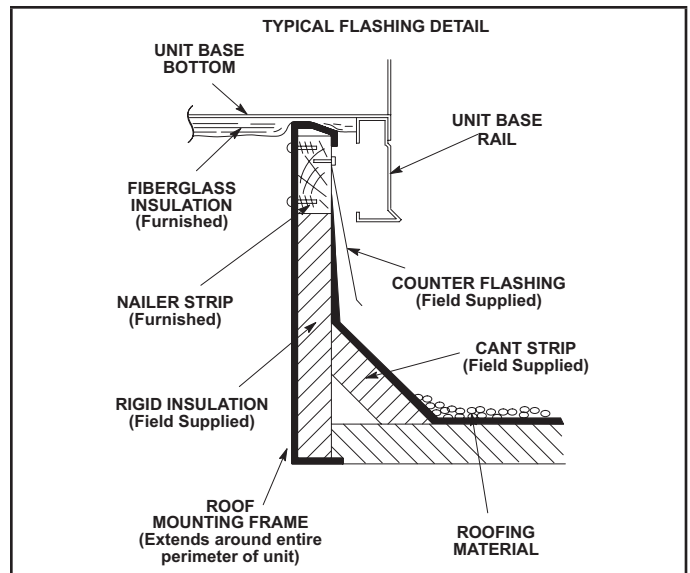

FIGURE 31

### D-Transitions

Optional supply/return transitions LASRT08/10 is available for use with the LGM 7.5 ton units and LASRT10/12 is available for the 8.5 and 10 ton units, utilizing optional C1CURB roof mounting frames. LGM 12.5 ton units will use LASRT15 with C1CURB roof mounting frame. Transition must be installed in the C1CURB mounting frame before mounting the unit to the frame. Refer to the manufacturer's instructions included with the transition for detailed installation procedures.

### E-LAOD(M) Outdoor Air Dampers (all units)

LAOD(M) consists of a set of dampers which may be manually or motor (M) operated to allow up to 25 percent outside air into the system at all times (see FIGURE 32 or FIGURE 33). Either air damper can be installed in LGM units. Washable filter supplied with the outdoor air dampers can be cleaned with water and a mild detergent. It should be sprayed with Filter Handicoater when dry prior to re-installation.

### F-Supply and Return Diffusers (all units)

Optional flush mount diffuser/return FD11 and extended mount diffuser/return RTD11 are available for use with all LGM units. Refer to manufacturer's instructions included with transition for detailed installation procedures.

### G-Blower Proving Switch S52

The blower proving switch monitors blower operation and locks out the unit in case of blower failure. The switch is N.O. and closes at .14" W.C. (34.9 Pa) The switch is mounted on the upper left hand corner of the blower deck. Wiring for the blower proving switch is shown on the temperature control section (C2) wiring diagram in back of this manual.

**LAOAD(M) MOTORIZED OUTDOOR AIR DAMPER**

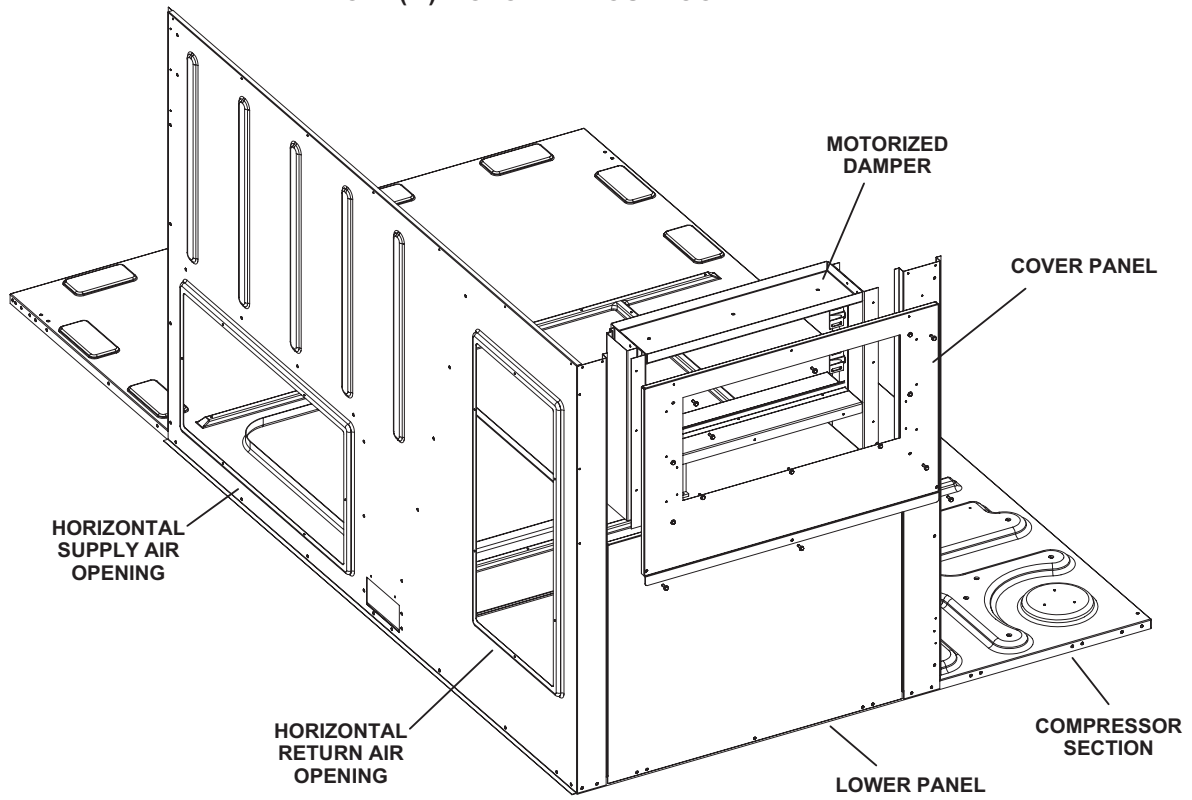

**FIGURE 32**

**MANUAL OUTDOOR AIR DAMPER**

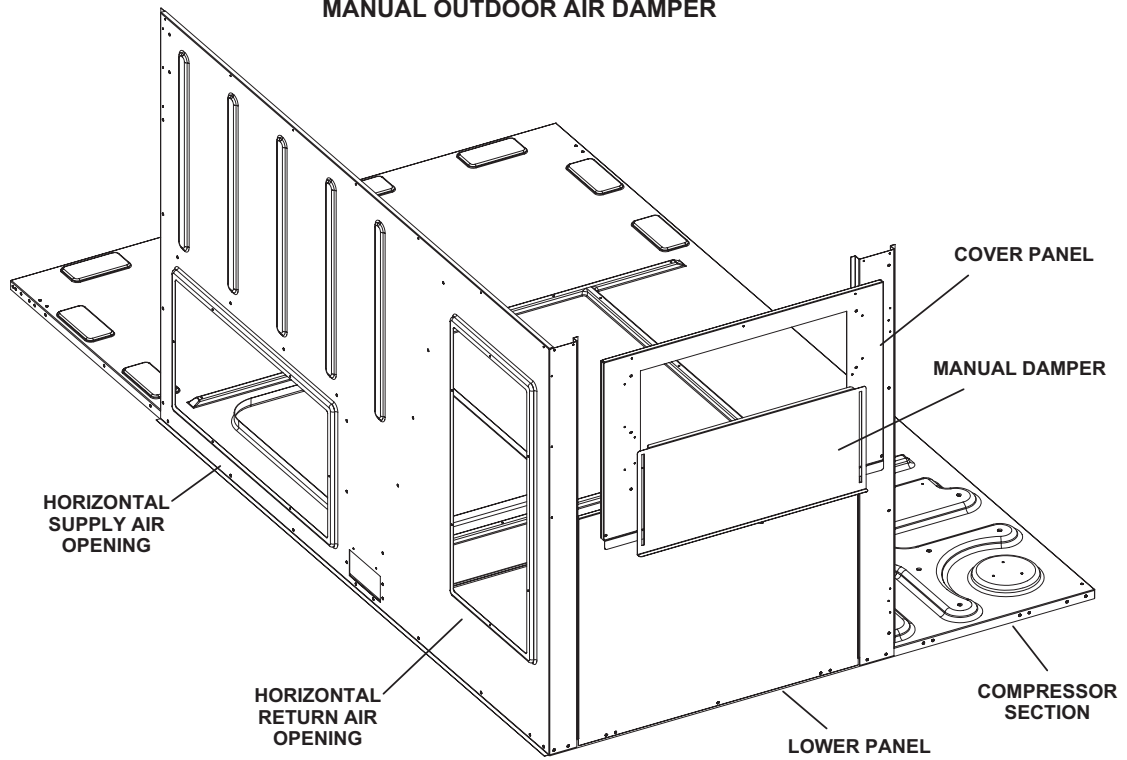

**FIGURE 33**

## H-Economizer (all units)

(Field or Factory Installed)

The optional E1ECON15 economizer can be used with downflow and horizontal air discharge applications. See FIGURE 34. The economizer uses outdoor air for free cooling when outdoor temperature and/or humidity is suitable. The economizer is controlled by the A55 Unit Controller.

### Free Cooling Mode

The Unit Controller will allow free cooling in one of five modes. Each mode uses different combinations of sensors to determine outdoor air suitability. See TABLE 19 for modes. See FIGURE 37 for factory-installed sensors. Temperature offset is the default free cooling mode.

**NOTE** - All free cooling modes of operation will modulate dampers to 55F (13C) supply / discharge air.

### Unit Controller Settings

Some versions require a configuration ID be entered to enable the economizer. Refer to economizer installation instructions and Unit Controller installation and application manuals.

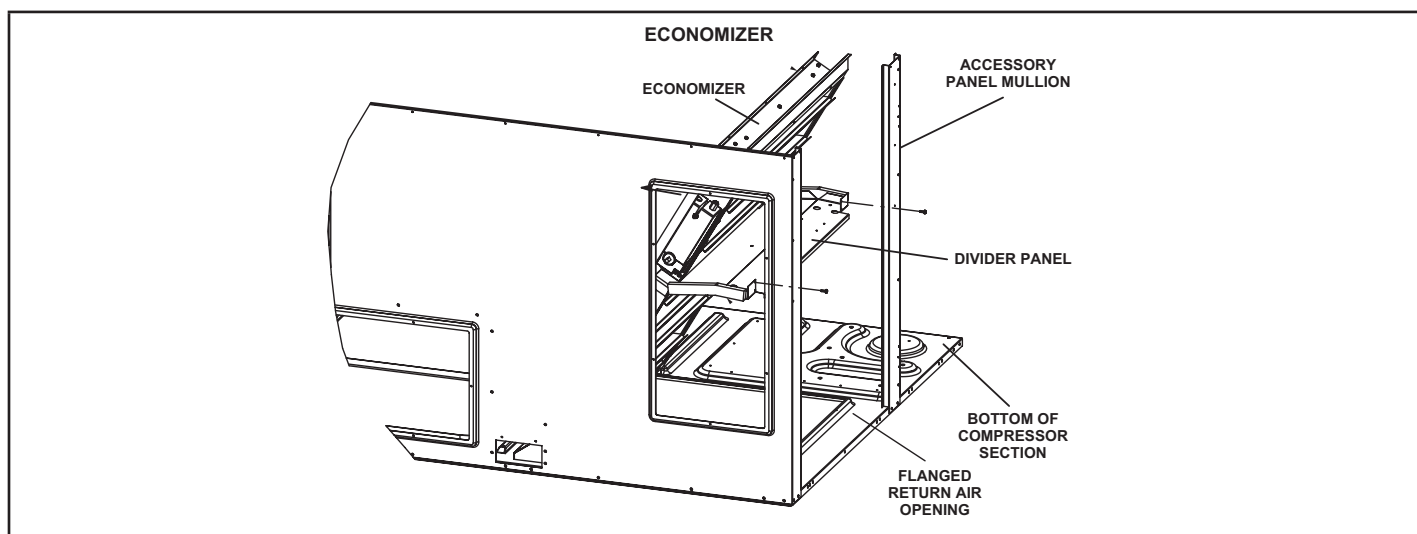

FIGURE 34

TABLE 19

ECONOMIZER MODES AND SETPOINT

Free Cooling Mode	Free Cooling Setpoint	Field-Provided Sensors	Dampers will modulate to 55°F (default, parameter 159) discharge air (RT6) when outdoor air is suitable:	Input Ranges
TEMP	OFFSET	None Needed	Outdoor air temperature (RT17) is less than return air temperature (RT16) by at least the OFFSET value (10°F default; parameter 161).	0 - 40°F
TEMP	OAT STPT	None Needed	Outdoor air temperature (RT17) is less than the OAT STPT value (75°F default; parameter 160).	41 - 75°F
Remote	Remote	Energy Management System	Either of the TEMP modes can be used when a network OAS signal is provided by an energy management or building control system, via BACnet, LonTalk, or L Connection. The network can command OAS, NOT OAS, or AUTO. AUTO returns to local control of OAS, which is the selected TEMP mode.	NA
ENTH	DIFF OFFSET	(Two) C7400	Outdoor air enthalpy* (A7) is less than return air enthalpy (A62) by at least the OFFSET value (1mA = 2°F default; parameter 163).	0Ma-4mA
ENTH	ODE STPT	C7400	Outdoor air enthalpy (A7) is less than free cooling setpoint (12mA = 75°F default, parameter 162).	12-19mA
GLOBAL	GLOBAL	24VAC Input Signal	Global input is energized by (P297-9). This setting is also used for outdoor air damper applications. Global input also brings on the blower. (This mode is NOT used when OAS signal is provided via network connection. GLO is only used when a 24VAC signal is used to energize the P297-9 GLO input.)	NA

## I-Gravity Exhaust Dampers

LAGEDH03/15 dampers (FIGURE 35) are used in down-flow and horizontal air discharge applications. Horizontal gravity exhaust dampers are installed in the return air plenum. The dampers must be used any time an economizer or power exhaust fans are applied to LGM units. Gravity exhaust dampers allow exhaust air to be discharged from the system when an economizer and/or power exhaust is operating. Gravity exhaust dampers also prevent outdoor air infiltration during unit off cycle. See installation instructions for more detail.

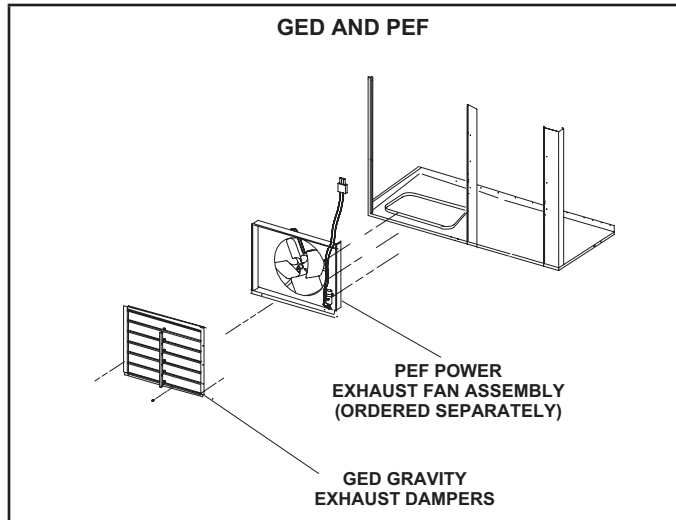

FIGURE 35

## J-LAPEF Power Exhaust Fans

Power exhaust fans are used in downflow applications only. Fan requires optional down flow gravity exhaust dampers and LAREMD economizer. Power exhaust fans provide exhaust air pressure relief and also run when return air dampers are closed and supply air blowers are operating. FIGURE 36 shows the location of the LAPEF. See installation instructions for more detail.

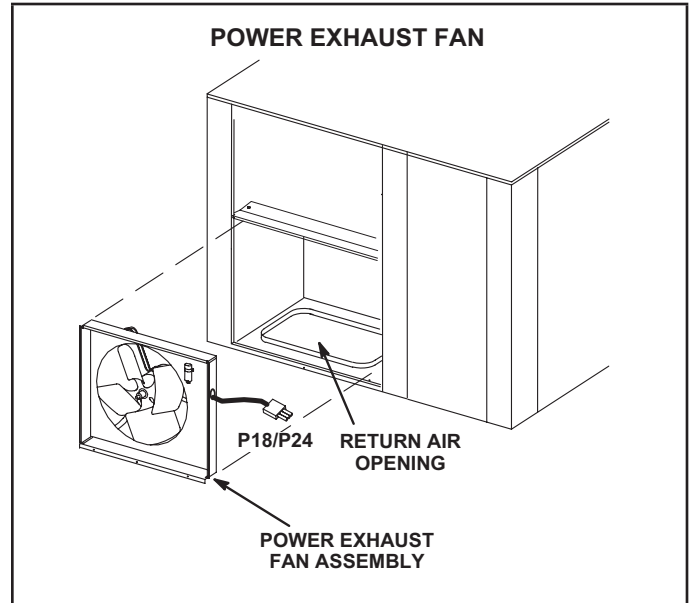

FIGURE 36

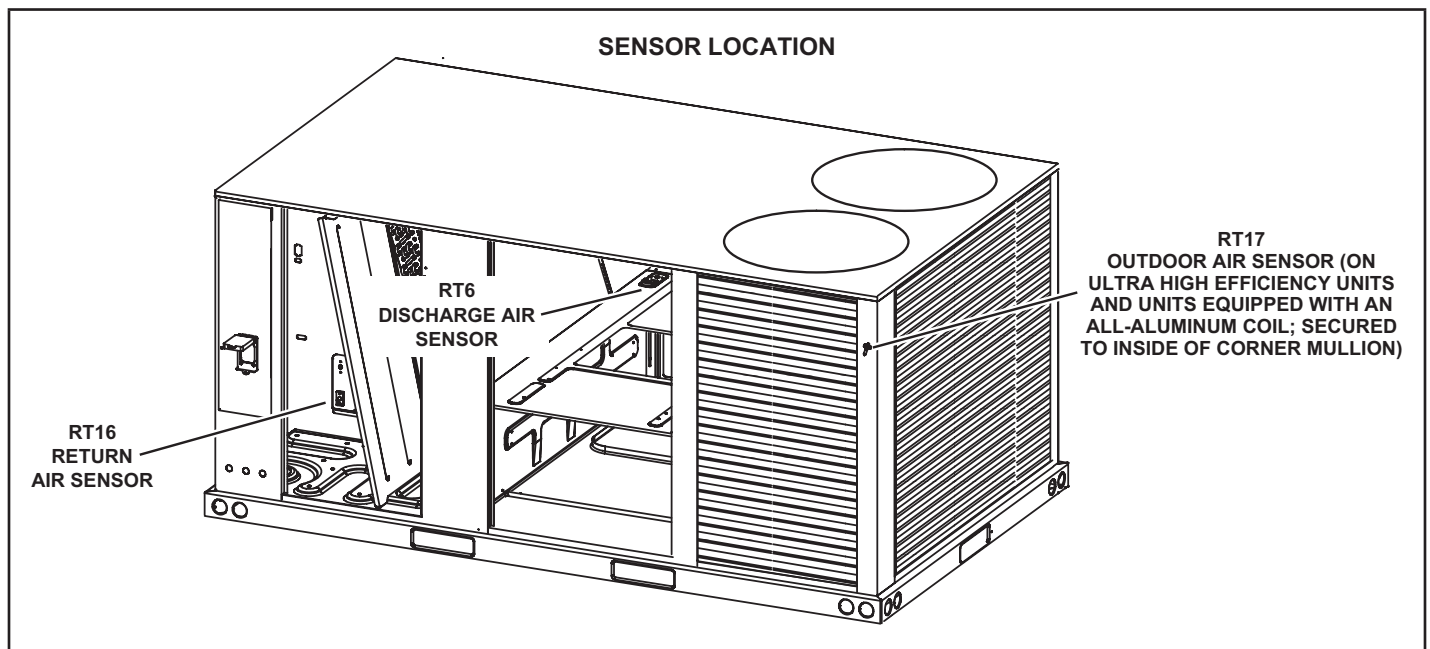

FIGURE 37

### **K-Optional Cold Weather Kit (Canada only)**

Electric heater is available to automatically control the minimum temperature in the gas burner compartment. Heater is C.G.A. certified to allow cold weather operation of unit down to -60° F (-50° C).

The kit includes the following parts:

- 1 - A heater assembly is installed on the vestibule of the heating compartment. Included in the box are the following:
  - a. Electric strip heat (HR6).
  - b. Thermostat switch (S59) is an auto-reset SPST N.C. switch which opens on a temperature drop. The switch is wired in series with 24v power and the combustion air blower switch. When the temperature drops below -30° F (-35° C) the switch opens and the gas heat section is de-energized. The switch automatically resets when the heating compartment temperature reaches -10° F (-12° C).
  - c. Thermostat switch (S60) is an auto-reset SPST N.C. switch which opens on a temperature rise. The switch is wired in series with HR6. When the temperature rises above 20° F (-7° C) the switch opens and the electric heater is de-energized. The switch automatically resets when the heating compartment temperature reaches -10° F (23.3° C).
  - d. Thermostat switch (S61) is an auto-reset SPST N.O. switch which closes on a temperature drop. The switch is wired in series with HR6. When temperature drops below 20° F (-7° C) the switch closes and electric heater is energized. The switch automatically opens when heating compartment temperature reaches 76° F (24° C).
- 2 - K125 heat shutoff relay de-energizes HR6 heaters when S60 or S61 thermostat switches open. K125 must be installed in the control section.
- 3 - Wire harness is routed between the heat section components and the unit control box. Follow instructions provided with kit for wire connections.

### **L-Control Systems**

The A55 Unit Controller provides all control function for the rooftop unit. Default operation requires a standard room thermostat or direct digital controller (DDC). The A55 can also control the unit from a zone temperature sensor. The A55 Unit Controller is a network controller when daisy-chained to the L Connection® Network Control System. For ease of configuration, the A55 can be connected to a PC with Unit Controller PC software installed.

### **M-Indoor Air Quality (CO2) Sensor A63**

The indoor air quality sensor monitors CO2 levels and reports the levels to the A55 Unit Controller. The board adjusts the economizer dampers according to the CO2 levels. The sensor is mounted next to the indoor thermostat or in the return air duct. Refer to the indoor air quality sensor installation instructions for proper adjustment. Wiring for the indoor air quality switch is shown on the temperature control section (C2) wiring diagram in back of this manual.

### **N-Drain Pan Overflow Switch S149 (optional)**

The overflow switch is used to interrupt cooling operation when excessive condensate collects in the drain pan. The N.C. overflow switch is connected to the Unit Controller (A55) through DI-3. When the switch opens, the Unit Controller will shut off the unit. After a five-minute time out, the Unit Controller will verify the overflow switch position and restart the unit (if the switch has closed). The Unit Controller has a three-strike counter before the unit locks out. This means the Unit Controller will allow the overflow switch to open three times per thermostat demand. If the unit locks out, a reset of the Unit Controller is required after the switch has closed to restore unit operation.

### **O-Smoke Detectors A17 and A64**

Photoelectric smoke detectors are a factory installed option. The smoke detectors can be installed in the supply air section (A64), return air section (A17), or in both the supply and return air section. Wiring for the smoke detectors are shown on the temperature control section (C2) wiring diagram in back of this manual.

### **P-Factory Installed-Hot Gas Reheat (optional)**

#### **General**

Hot Gas Reheat units provide a dehumidifying mode of operation. These units contain a reheat coil adjacent to and downstream of the evaporator coil. Reheat coil solenoid valve, L14, routes hot discharge gas from the compressor to the reheat coil. Return air pulled across the evaporator coil is cooled and dehumidified; the reheat coil adds heat to supply air. See FIGURE 38 for reheat refrigerant routing and FIGURE 39 for standard cooling refrigerant routing.

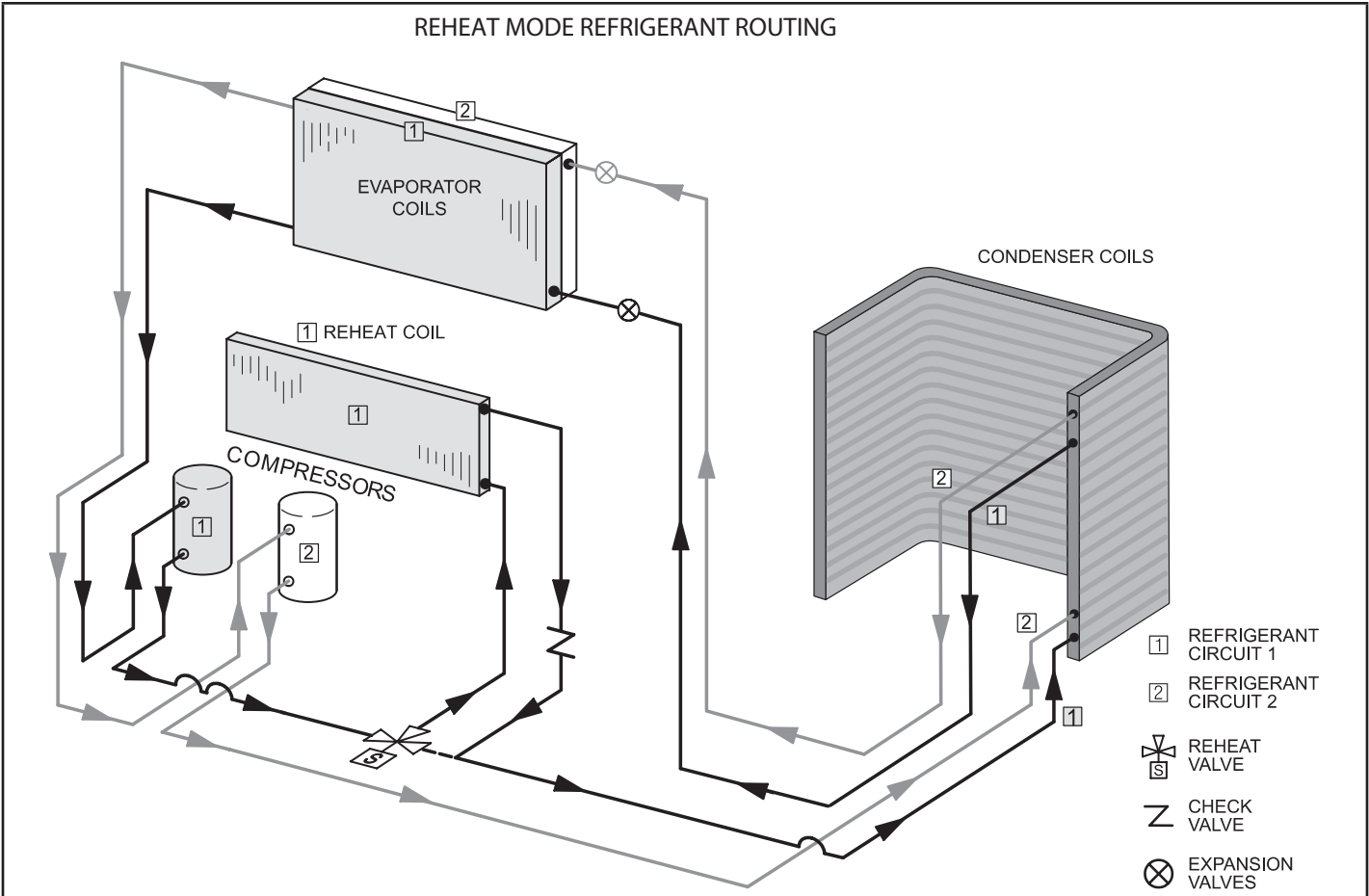

**FIGURE 38**

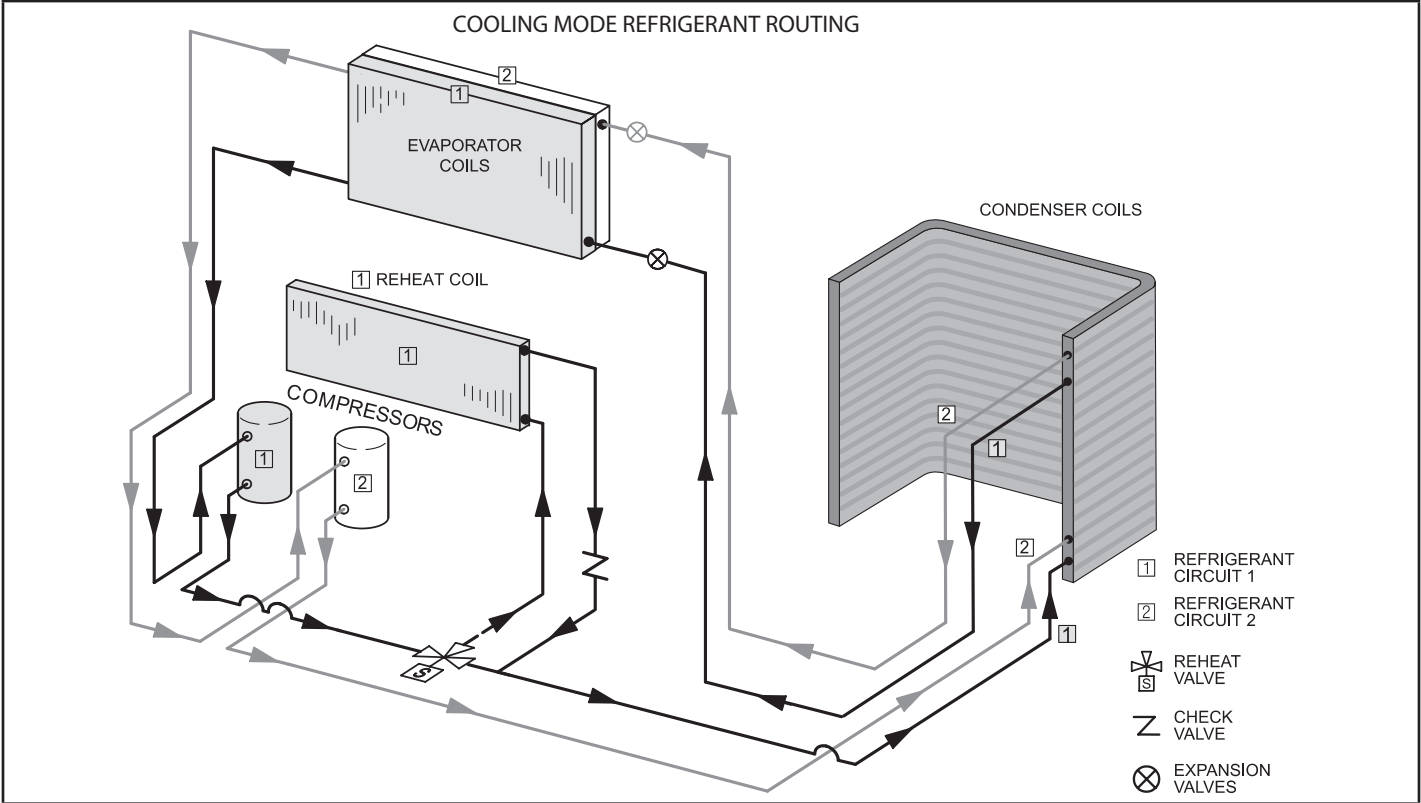

**FIGURE 39**

## L14 Reheat Coil Solenoid Valve

When Unit Controller input (Unit Controller J298-5 or J299-8) indicates room conditions require dehumidification, L14 reheat valve is energized (Unit Controller P269-3) and refrigerant is routed to the reheat coil.

### Reheat Setpoint

Reheat is factory-set to energize when indoor relative humidity rises above 60% (default). The reheat setpoint can be adjusted by changing Unit Controller Settings - Control menu. A setting of 100% will operate reheat from an energy management system digital output. The reheat setpoint can also be adjusted using an optional Network Control Panel (NCP). Reheat will terminate when the indoor relative humidity falls 3% (57% default) or the digital output de-energizes. The reheat deadband can be adjusted at Settings - Control menu.

### Check-Out

Test Hot Gas Reheat operation using the following procedure.

- 1 - Make sure reheat is wired as shown in wiring section.
- 2 - Make sure unit is in local thermostat mode.
- 3 - Select Unit Controller *Service - Test*.

*The blower and compressor 1 (reheat) should be operating. Reheat mode will be appear on the Unit Controller display.*

- 4 - Deselect Unit Controller *Service - Test*.

*Compressor 1 (reheat) and blower should de-energize.*

### Default Reheat Operation

**TABLE 20**

**Reheat Operation - Two Cooling Stages - Default**

T'stat and Humidity Demands	Operation
Reheat Only	Compressor 1 Reheat
Reheat & Y1	Compressor 1 2 Enhanced Dehumidification at Low CFM
Reheat & Y1 & Y2	Compressor 1 & 2 Enhanced Dehumidification at High CFM

\*If there is no reheat demand and outdoor air is suitable, free cooling will operate.

\*\*If there is no reheat demand and outdoor air is suitable, free cooling and compressor 1 will operate.

### K-UVC Light

When field-installed, use only UVC Light Kit assembly 106882-01 (21A93) with this appliance.

#### Factory-Installed UVC Light

When the UVC light is factory installed, the lamp is shipped in a foam sleeve. The lamp is attached to the UVC light assembly on the blower deck. See FIGURE 41. Remove the lamp and install into the UVC light assembly as shown in steps 2 through 11.

## Annual Lamp Replacement

### **WARNING**

#### Personal Burn Hazard

Personal injury may result from hot lamps. During replacement, allow lamp to cool for 10 minutes before removing lamp from fixture.

The lamp should be replaced every 12 months, as UVC energy production diminishes over time.

- 1 - Obtain replacement lamp 101087-01 for your germicidal light model.
- 2 - Disconnect power to the rooftop unit before servicing the UVC kit. Open the blower access door.
- 3 - Remove the screw in wire tie from the UVC assembly and disconnect the 4-pin connector from the lamp end.
- 4 - Remove and retain the (3) screws securing the UVC assembly. Carefully slide the complete UVC assembly out through the blower access door. See FIGURE 40.

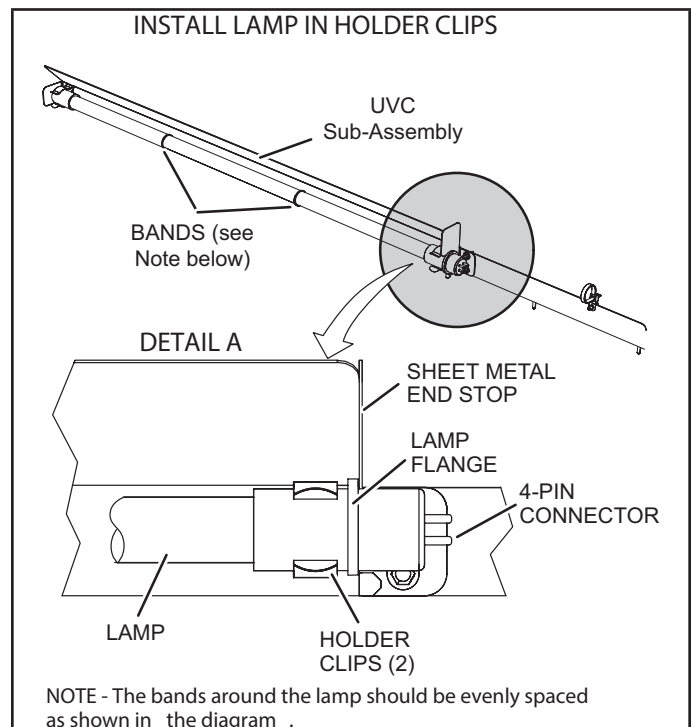

**FIGURE 40**

- 5 - Allow 10 minutes before touching the lamps. Then, carefully remove the old lamp from the lamp holder clips.
- 6 - Wear cotton gloves or use a cotton cloth when handling the new lamp. Place the new lamp in the holder clips of the UVC assembly. Verify that the lamp flange at the connector end is sandwiched between the lamp holder clip and the sheet-metal end stop (see FIGURE 40).
- 7 - Carefully place the UVC assembly on the blower deck. Line up the mounting holes on the UVC assembly with the mounting holes on the blower deck. See FIGURE 41. Use the retained screws provided to attach the UVC assembly in place.

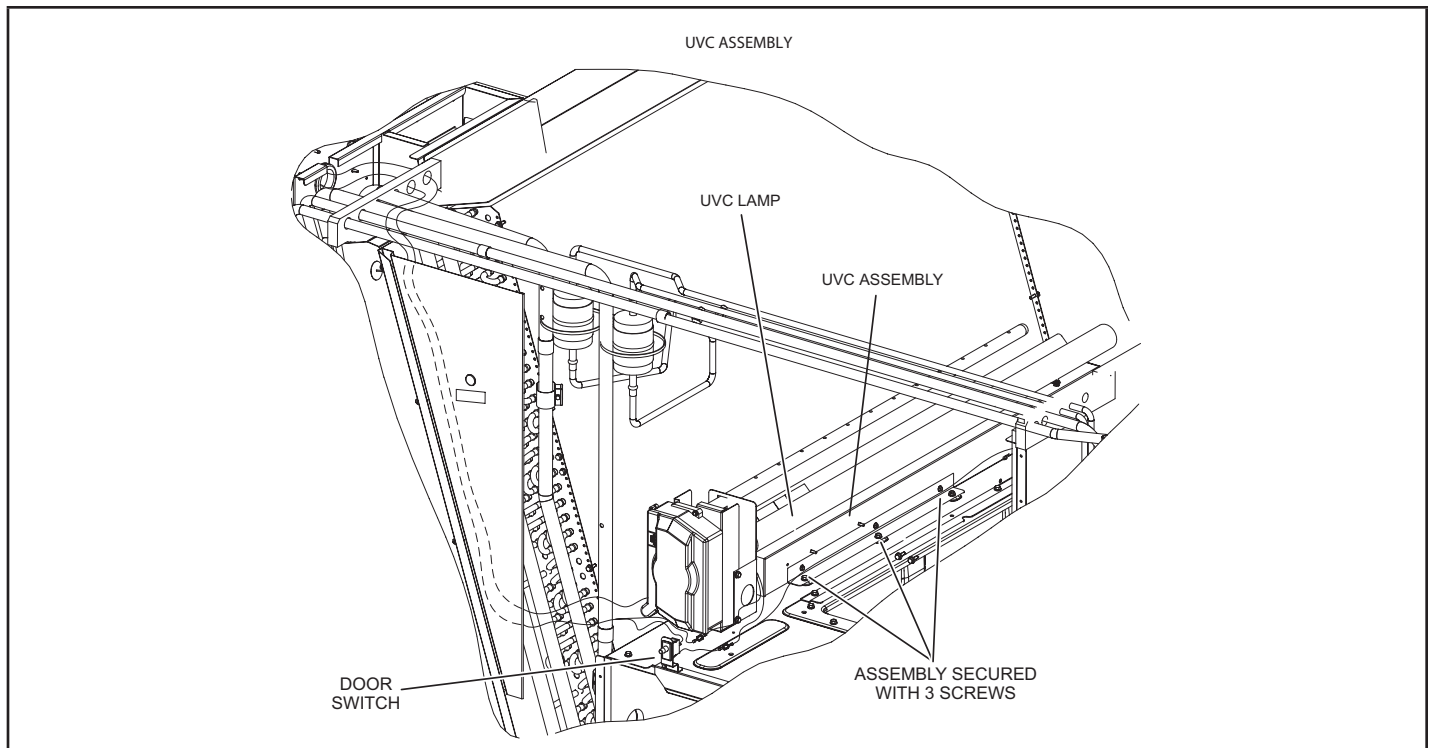

**FIGURE 41**

- 8 - Close the blower access door.
- 9 - Reconnect power to the rooftop unit.
- 10 - Open the filter access door and look through the view port in the triangular sheet-metal panel to verify that the UVC light is on.

If UVC lamp does not come on:

- 1 - Check Power Wiring: Disconnect 1/4" QC (quick connects) of the UVC cable near the UVC assembly. With Power ON, use multimeter to test 110-230V at the 1/4"QC quick connects from the control panel.
- 2 - Check Lamp: Carefully remove the UVC assembly out of the rooftop unit. Use multimeter to test for continuity across each pair of pins at each end of the lamp.
- 3 - Check Lamp Installation: Make sure that lamp's pins snap properly into the lamp holder.

**LED(s) not illuminated**

Power status LED not lit—Check that the lamp unit is connected to the proper power source and is wired correctly.

**Lamp status LED(s) not lit**

- 1 - Check that lamp 4-pin connectors are properly engaged.
- 2 - Ohm-check across the lamp pins to check for continuity of lamp filaments (see FIGURE 43).

Troubleshooting charts are provided to aid in determining the cause of any problems encountered (FIGURE 42 and FIGURE 43).

**Lamp Disposal**

**NOTE - UV Lamp Contains Mercury. Dispose According to Local, State, or Federal Laws. Refer to [www.lamprecycle.org](http://www.lamprecycle.org) or call 800-953-6669.**

**Proper Clean-up Technique in Case of Lamp Breakage**

Wear protective gloves, eye wear and mask.

Sweep the broken glass and debris into a plastic bag, seal the bag, and dispose of properly. Contact your local waste management office for proper disposal.

**Do not use a vacuum cleaner. Do not incinerate.**

**Maintenance**

- For all maintenance, contact a qualified HVAC technician.
- Read the maintenance instructions before opening unit panels.
- Unintended use of the unit or damage to the unit housing may result in the escape of dangerous UVC radiation. UVC radiation may, even in small doses, cause harm to the eyes and skin.
- Do not operate units that are obviously damaged.
- Do not discard the triangular UVC light shield or any barriers with an ultraviolet radiation symbol.
- Do not override the door interlock switch that interrupts power to the UVC light.
- Do not operate the UVC light outside of the unit.

**⚠ DANGER**

**Ultraviolet (UVC) Radiation hazard.**  
 Any exposure will cause significant eye damage and may cause skin damage.  
**DO NOT** look into UVC light source.  
 Access panels must be in place during appliance operation.

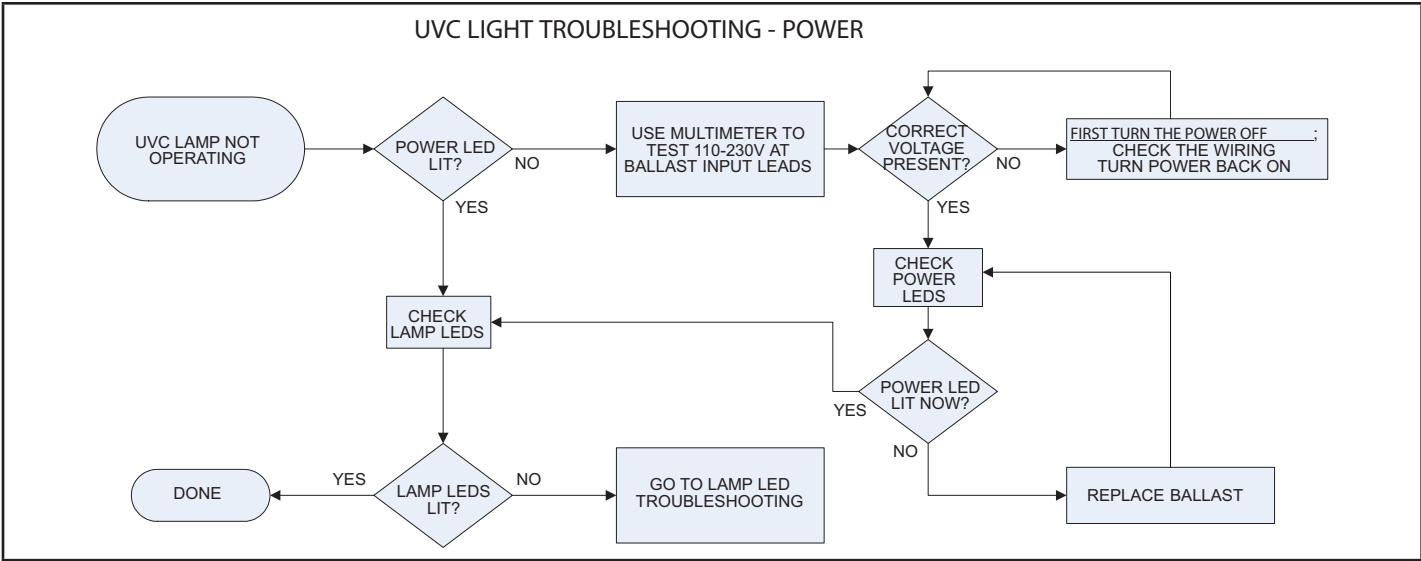

**FIGURE 42**

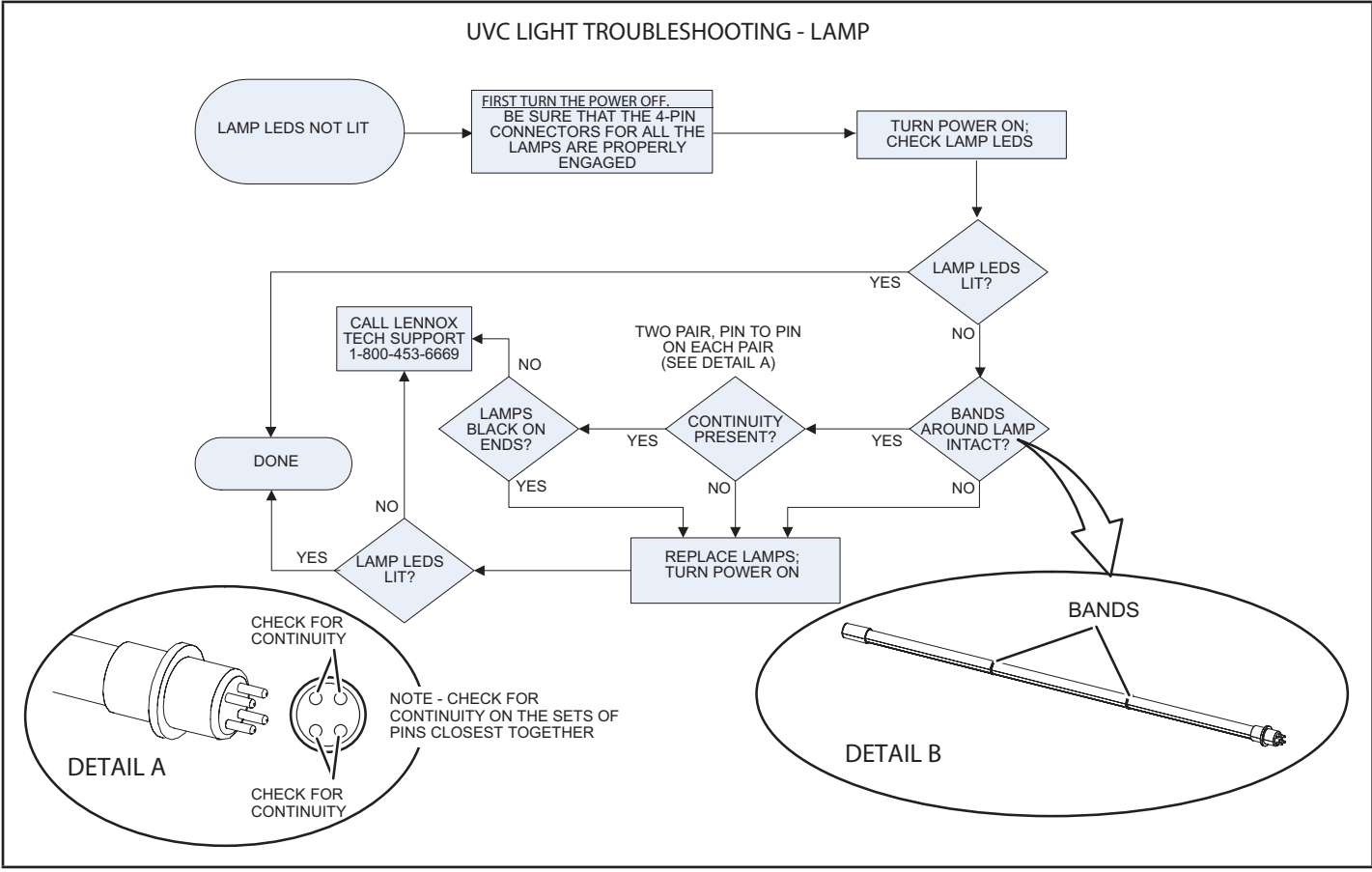

**FIGURE 43**

## VIII-Direct Drive Supply Air Inverter

If a test and balance contractor has not commissioned the unit, use this section to set supply air CFM.

### A-Set Blower Speed

- 1 - Use TABLE 21 to fill in field-provided, design specified blower CFM

**TABLE 21**

**Blower CFM Design Specifications**

Blower Speed	Design Specified CFM
Heating	
Cooling High	
Cooling Low	
Ventilation	

- 2 - Use the following menu to enter the blower design specified CFM into the Unit Controller. Don't press "SAVE" until all CFM are entered. Make sure blower CFM is within limitations shown in TABLE 22. Refer to the Unit Controller manual provided with unit.

SETUP > TEST & BALANCE > BLOWER

- 3 - Once all four speeds are entered, the target (highest of the heating and cooling settings) CFM and default RPM will be displayed.

**Note - When units are not equipped with heat, the Blower Heat speed will not be displayed. Blower Cooling High will be the first blower speed to appear.**

- 4 - Measure the static pressure as shown in the Blower Start-Up section. Use the static pressure, target CFM and blower tables to determine the RPM needed. Values in the blower table reflect the static pressures taken in locations shown in FIGURE 13.
- 5 - Enter the RPM and repeat the previous step until the design CFM is reached.
- 6 - Press SAVE followed by MAIN MENU.

**Note - Once the CFM settings are saved, the Unit Controller will set all other blower CFM.**

### B-Set Damper Minimum Position

To maintain required minimum ventilation air volumes when the unit is in the occupied mode, two minimum damper positions must be set. The Unit Controller will open the dampers to "Min OCP Blwr Low" when blower CFM is BELOW a "midpoint" CFM. The Unit Controller will open the damper to "Min OCP Blwr High" when blower CFM is at or ABOVE the "midpoint" CFM.

The Unit Controller will calculate the "midpoint" CFM.

#### Set Minimum Position 1

Use the following menu in the Unit Controller to set "Min OCP Blwr Low" for the blower CFM below the "midpoint" CFM. When navigating into this menu, the Unit Controller will bring on the corresponding blower speed and allow damper position adjustment.

SETTINGS > RTU Options > EDIT PARAMETER > ENTER DATA ID - 9 > MIN DAMPER LOW BLOWER = X.X %

Measure the intake air CFM. If the CFM is lower than the design specified CFM for ventilation air, use the Unit Controller to increase the damper percent open. If the CFM is higher than specified, decrease the damper percent open.

**Note - Intake air CFM can also be determined using the outdoor air temperature, return air temperature and mixed air temperature. Refer to the economizer or outdoor air damper installation instructions.**

#### Set Minimum Position 2

Use the same menu in the Unit Controller to set "Min OCPm Blwr High" for the blower CFM above the "midpoint" CFM. When navigating into this menu, the Unit Controller will bring on the corresponding blower speed and allow damper position adjustment.

SETTINGS > RTU OPTIONS > DAMPER > MIN DAMPER POSITION BLOWER ON HIGH = X.X %

Measure the intake air CFM. If the CFM is lower than the design specified CFM for ventilation air, use the Unit Controller to increase the damper percent open. If the CFM is higher than specified, decrease the damper percent open.

**Note - Intake air CFM can also be determined using the outdoor air temperature, return air temperature and mixed air temperature. Refer to the economizer or outdoor air damper installation instructions.**

**TABLE 22**

**MINIMUM AND MAXIMUM CFM**

Cooling Low Minimum CFM		
Unit	Blower Speed	Airflow CFM
LGM092-150	Low	800
Cooling High Minimum CFM - 250 CFM/ton		
Unit	Blower Speed	Airflow CFM
LGM092	High	1875
LGM102	High	2125
LGM120	High	2500
LGM150	High	3125
Smoke and Ventilation Minimum CFM - 150 CFM/ton		
Unit	Not Applicable	Airflow CFM
LGM092	NA	1125
LGM102	NA	1275
LGM120	NA	1500
LGM150	NA	1875
Heating and Cooling Maximum CFM - 480 CFM/ton		
Unit	Blower Speed	Airflow CFM
LGM092	High	3600
LGM102	High	4075
LGM120	High	4800
LGM150	High	6000

\*Rounded to nearest 25 CFM.

# IX-Wiring Diagrams and Sequence of Operation

## GAS HEAT FOR LGM092/150 UNITS Y and G Voltage

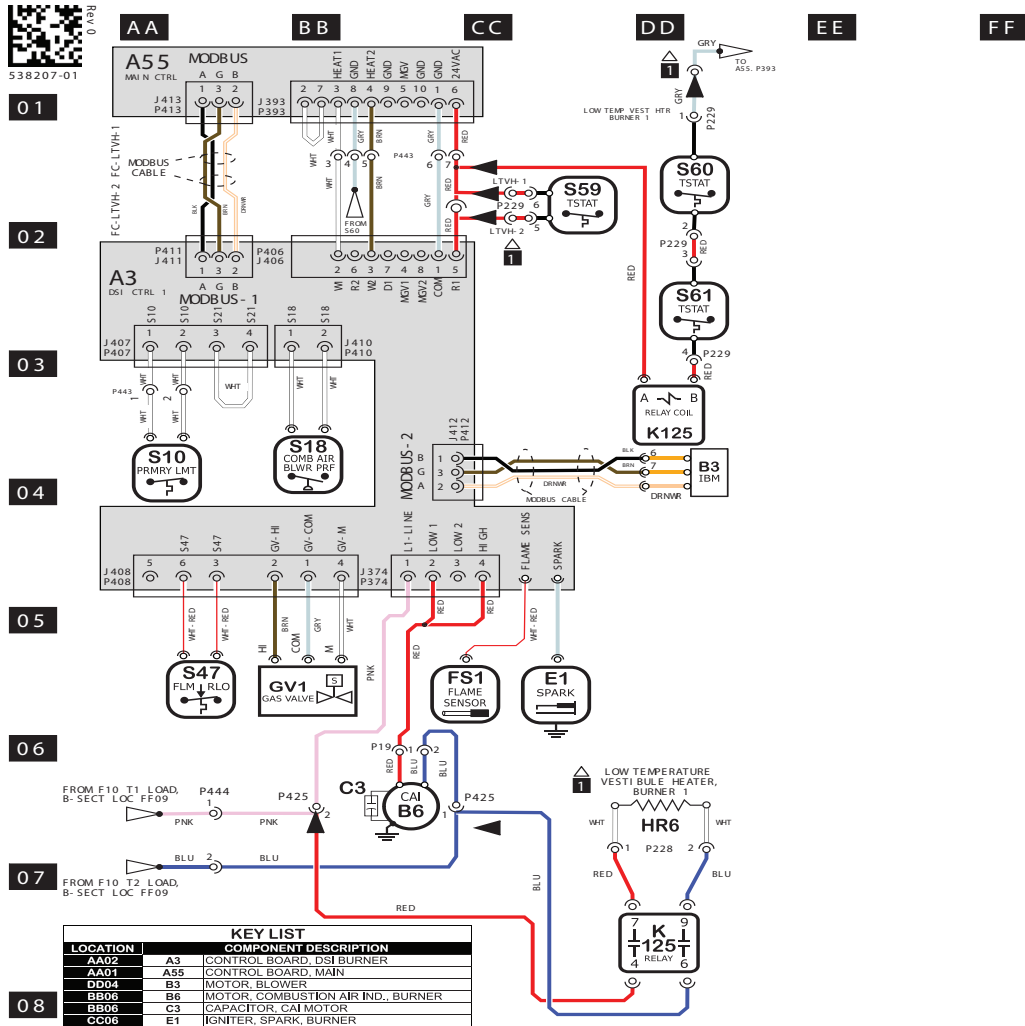

**KEY LIST**

LOCATION	COMPONENT DESCRIPTION
AA02	A3 CONTROL BOARD, DSI BURNER
AA01	A55 CONTROL BOARD, MAIN
DD04	B3 MOTOR, BLOWER
BB06	B6 MOTOR, COMBUSTION AIR IND., BURNER
BB06	C3 CAPACITOR, CAI MOTOR
CC06	E1 IGNITER, SPARK, BURNER
CC06	FS1 SENSOR, FLAME, BURNER
DD06	B606 VALVE, GAS, BURNER
DD06	HR6 HEATER, -50C LOW TEMP VEST. BURNER
CC03/CC08	K125 RELAY, LOW TEMP VEST HEATER, BURNER
DD06	K125 RELAY, LOW TEMP VEST HEATER, BURNER
AA04	S10 LIMIT, PRIMARY, BURNER
BB04	S18 SWITCH, COMB AIR BLWR PROOF, BURNER
AA05	S47 SWITCH, FLAME ROLL-OUT, BURNER
AA01	S59 TSTAT, OPEN -20F, CLOSE 10F, BURNER
CC02	S60 TSTAT, OPEN 20F, CLOSE 10F, BURNER
CC03	S61 TSTAT, OPEN 50F, CLOSE 20F, BURNER

← DENOTES OPTIONAL COMPONENTS AND WIRING  
 ▲ NOTES  
 1 - 50C LOW TEMPERATURE VESTIBULE HEATER - OPTIONAL

10 Model: LG\*/LD\* Series RTU - Gas Heat  
 130k, 180k, 240k BtuH  
 Voltage: 208/240/3/60(Y), 460/3/60(G)  
 Supersedes: XXXXXX-XX Form No: 538207-01 Rev: 0

© 2019

HEATING	COOLING	COOLING	ACCS	ACCS
SECTION A	SECTION B	SECTION B3/S	SECTION C	SECTION D

WIRING DIAGRAM FLOW

7 x 10  
CUT SIZE

REV	EC NO.	DATE	BY	APVD	REVISION NOTE
---	CN-012081C	04-29-2024	FEP	MCF	ORIGINATED AT PD&R CARROLLTON, TX

# GAS HEAT FOR LGM092/150 UNITS J Voltage

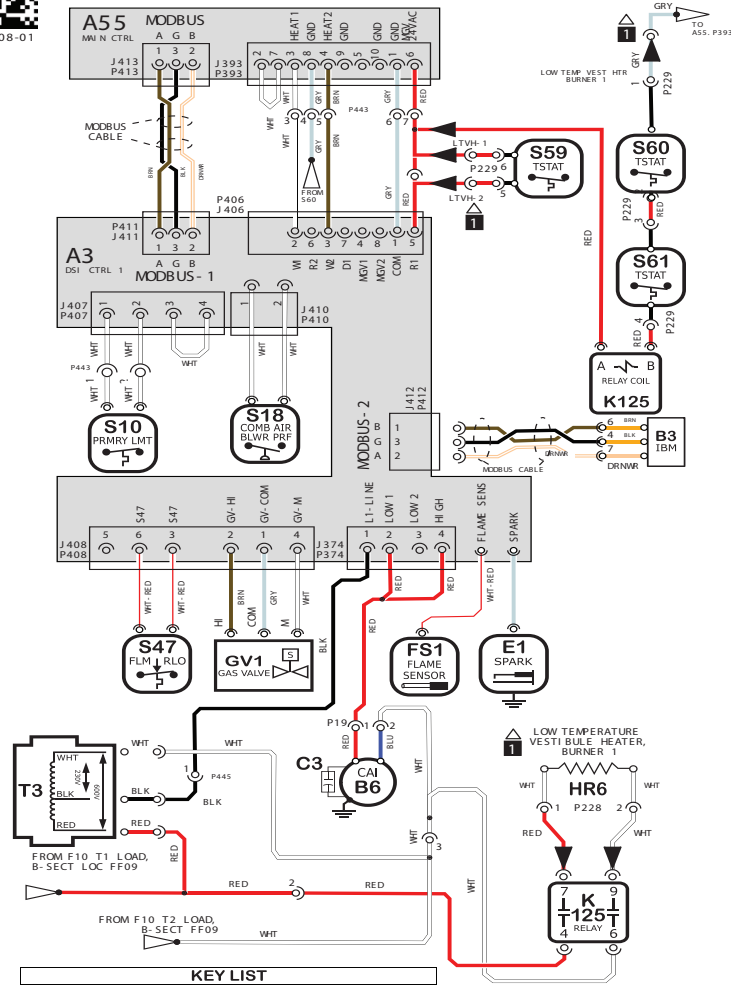

KEY LIST	
LOCATION	COMPONENT DESCRIPTION
AA02	A3 CONTROL BOARD, DSI BURNER
AA01	A55 CONTROL BOARD, MAIN
DD04	B3 MOTOR, BLOWER
BB06	B6 MOTOR, COMBUSTION AIR IND., BURNER
BB06	C3 CAPACITOR, CAI MOTOR
CC06	E1 IGNITER, SPARK, BURNER
CC06	FS1 SENSOR, FLAME, BURNER
DD06	GV1 VALVE, GAS, BURNER
DD08	HR6 HEATER, -50C LOW TEMP VEST. BURNER
CC08/DD06	K125 RELAY, LOW TEMP VEST HEATER, BURNER
AA04	S10 LIMIT, PRIMARY, BURNER
BB04	S18 SWITCH, COMB AIR BLWR PROOF, BURNER
AA05	S47 SWITCH, FLAME ROLLOUT, BURNER
AA01	S59 TSTAT, OPEN 20F, CLOSE 10F, BURNER
CC02	S60 TSTAT, OPEN 20F, CLOSE 10F, BURNER
CC03	S61 TSTAT, OPEN 50F, CLOSE 20F, BURNER
AA06/AA07	T3 TRANSFORMER, COMBUSTION AIR BLOWER

Model: LG\*/LD\* Series RTU - Gas Heat - J VOLT  
 130k, 180k, 240k Btu/H  
 Voltage: 575/3/60 (J)  
 Supersedes: XXXXX-XX Form No: 538208-01 Rev: 0

← DENOTES OPTI ONAL COMPONENTS AND W I R I N G  
 ▲  
 1 -50C LOW TEMPERATURE VESTIBULE HEATER - OPTIONAL

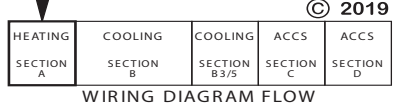

REV	EC NO.	DATE	BY	APVD	REVISION NOTE
---	CN-012081C	04-29-2024	FEP	MCF	ORIGINATED AT PD&R CARROLLTON, TX

## GAS HEAT SEQUENCE OF OPERATION LGM092-150

### First Stage Heat:

- 1 - Heating demand initiates at W1 in the thermostat.
- 2 - 24VAC is routed through the A55 unit controller to A3 Ignition Control. The Ignition control then routes the 24VAC to the N.C. primary limit S10. The A3 Ignition control energizes the combustion air blower B6.
- 3 - After the combustion air blower B6 has reached full speed, the combustion air proving switch S18 contacts close. The A3 routes 24VAC through N.C. burner flame roll-out switch S47 and the closed contacts of combustion air proving switch S18 to energize the ignition module A3.
- 4 - After a 30 second delay A3 energizes the ignitor and LO terminal (low fire) of gas valve GV1.

### Second Stage Heat:

- 5 - With first stage heat operating, an additional heating demand initiates W2 in the thermostat.
- 6 - A second stage heating demand is received by A55 unit Controller.
- 7 - A55 provides the 24VAC to the A3 Ignition control. This is routed to the HI Terminal (high fire) of gas valve GV1.

### End of Second Stage Heat:

- 8 - Heating demand is satisfied. Terminal W2 (high fire) is de-energized.
- 9 - Terminal HI of GV1 is de-energized by A3 control module.

### End of First Stage Heat:

- 10 - Heating demand is satisfied. Terminal W1 (low fire) is de-energized.
- 11 - Ignition A3 is de-energized by control module A55 in turn de-energizing terminal LO of GV1. Combustion air blower relay K13 located in the A3 ignition control is also de-energized.

### Optional Low Ambient Kit:

#### (C.G.A. -50° C Low Ambient Kit)

- 12 - Line voltage (or transformer T20 in 460V and 575V only) is routed through the low ambient kit fuses F20 and N.C. low ambient kit thermostats S60 and S61, to energize low ambient kit heater HR6.

# THERMOSTAT

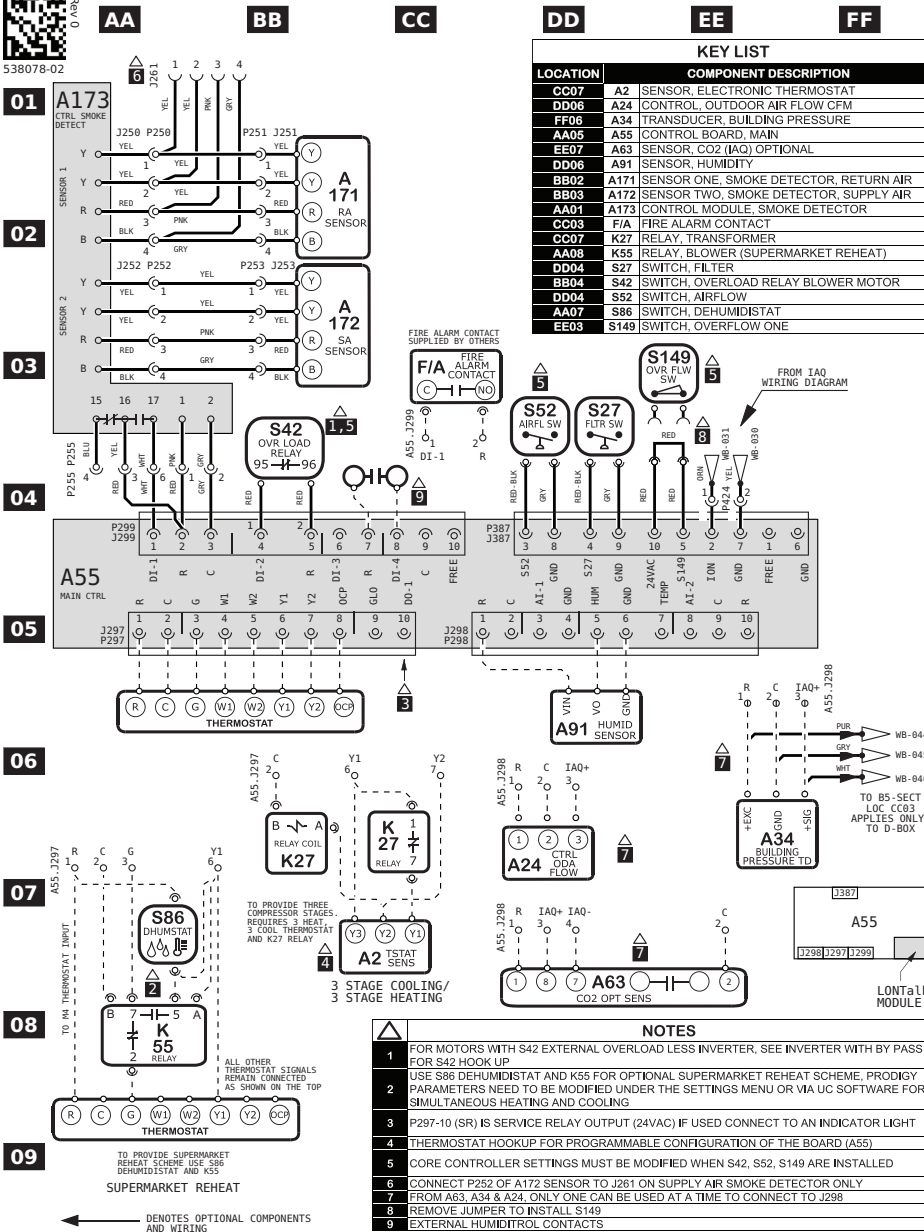

LOCATION	COMPONENT DESCRIPTION
CC07	A2 SENSOR, ELECTRONIC THERMOSTAT
DD08	A24 CONTROL, OUTDOOR AIR FLOW CFM
FF06	A34 TRANSDUCER, BUILDING PRESSURE
AA06	A55 CONTROL BOARD, MAIN
EE07	A63 SENSOR, CO2 (IAQ) OPTIONAL
DD06	A91 SENSOR, HUMIDITY
BB02	A171 SENSOR ONE, SMOKE DETECTOR, RETURN AIR
BB03	A172 SENSOR TWO, SMOKE DETECTOR, SUPPLY AIR
AA01	A173 CONTROL MODULE, SMOKE DETECTOR
CC03	F/A FIRE ALARM CONTACT
CC07	K27 RELAY, TRANSFORMER
AA08	K55 RELAY, BLOWER (SUPERMARKET REHEAT)
DD04	S27 SWITCH, FILTER
BB04	S42 SWITCH, OVERLOAD RELAY BLOWER MOTOR
DD04	S52 SWITCH, AIRFLOW
AA07	S86 SWITCH, DEHUMIDISTAT
EE03	S149 SWITCH, OVERFLOW ONE

- NOTES**
- FOR MOTORS WITH S42 EXTERNAL OVERLOAD LESS INVERTER, SEE INVERTER WITH BY PASS FOR S42 HOOK UP
  - USE S86 DEHUMIDISTAT AND K55 FOR OPTIONAL SUPERMARKET REHEAT SCHEME. PRODIGY PARAMETERS NEED TO BE MODIFIED UNDER THE SETTINGS MENU OR VIA UC SOFTWARE FOR SIMULTANEOUS HEATING AND COOLING
  - P297-10 (SR) IS SERVICE RELAY OUTPUT (24VAC) IF USED CONNECT TO AN INDICATOR LIGHT
  - THERMOSTAT HOOKUP FOR PROGRAMMABLE CONFIGURATION OF THE BOARD (A55)
  - CORE CONTROLLER SETTINGS MUST BE MODIFIED WHEN S42, S52, S149 ARE INSTALLED
  - CONNECT P252 OF A172 SENSOR TO J261 ON SUPPLY AIR SMOKE DETECTOR ONLY
  - FROM A63, A34 & A24, ONLY ONE CAN BE USED AT A TIME TO CONNECT TO J298
  - REMOVE JUMPER TO INSTALL S149
  - EXTERNAL HUMIDITY CONTROL CONTACTS

Model: LC, LG, LH, LD Series RTU  
 Thermostat  
 Voltage: All Voltages  
 Supersedes: 538078-01 Form No: 538078-02 Rev: 0

HEATING	COOLING	COOLING	ACCS	ACCS
SECTION A	SECTION B	SECTION B3/5	SECTION C	SECTION D
WIRING DIAGRAM FLOW				



REV	EC NO.	DATE	BY	APVD	REVISION NOTE
---	CN-012295C	04-03-2024	MXR6	MXT5	ORIGINATED AT PD&R CARROLLTON, TX

# ECONOMIZER

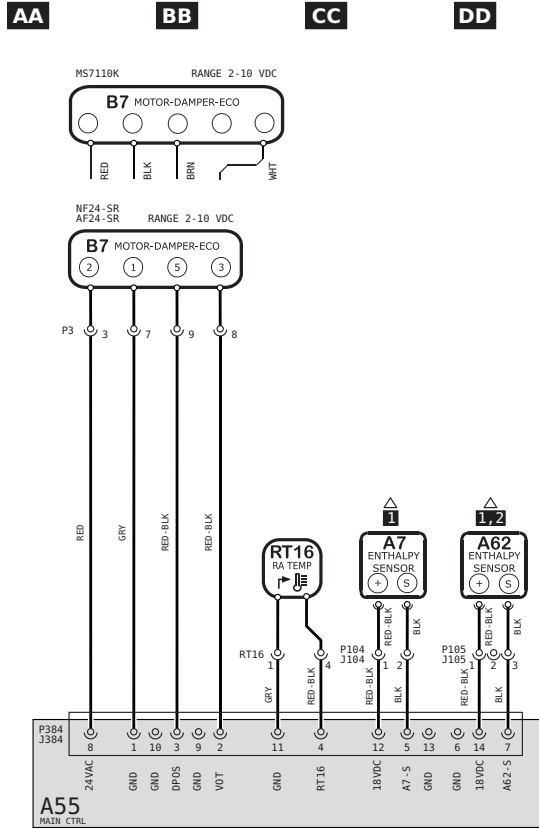

**07**

NOTES	
1	A7 AND A62 NOT USED FOR SENSIBLE TEMPERATURE CONTROL
2	FOR UNIT DIFFERENTIAL ENTHALPHY CONTROL, ADD A62 RETURN AIR ENTHALPHY SENSOR

**08**

KEY LIST		
LOCATION	COMPONENT DESCRIPTION	
CC05	A7	SENSOR, SOLID STATE ENTHALPHY
AA06	A55	CONTROL BOARD, MAIN
DD05	A62	SENSOR, ENTHALPHY INDOOR
BB02	B7	MOTOR, DAMPER ECONOMIZER
CC05	RT16	SENSOR, RETURN AIR TEMP

**09**

**10** Model: LC,LG,LH,LD,SC,SG Series Economizer & Motorized OAD  
 Voltage: All Voltages  
 Supersedes: N/A Form No: 538072-01 Rev: 2

© 2019

HTG SEC A	CLG SEC B	CLG SEC B3	ACCS SEC C	ACCS SEC D
-----------	-----------	------------	------------	------------

WIRING DIAGRAM FLOW



REV	EC NO.	DATE	BY	APVD	REVISION NOTE
---	CN-008594	10/15/2020	RV	MXR6	ORIGINATED AT PD&R CARROLLTON, TX
001	CN-010356B	03/24/2022	MXR6	JAL21	UPDATED APPLICABLE MODEL NUMBERS.
002	CN-012457P	03/06/2024	AXL	AAH	A) ADDED SC, SG TO MODELS

## **SEQUENCE OF OPERATION LGM092U-150U**

### **Power:**

- 1 - Line voltage through the TB13 terminal block powers the T1 transformer. T1 provides 24VAC power to A55 Unit Controller which provides 24VAC to the unit cooling, heating and blower controls.
- 2 - Line voltage is also routed to compressor crankcase heaters, compressor contactors, supply air inverter control, condenser fan relays and exhaust fan relays.

### **Blower Operation:**

Refer to Direct Drive blower diagram and sequence of operation.

### **Economizer Operation:**

- 3 - A55 receives a demand and energizes exhaust fan relay K65 with 24VAC at 50% outside air damper open (adjustable).
- 4 - N.O. K65-1 and N.O. K65-2 both close, energizing exhaust fan motor B10.

### **Cooling Operation:**

- 1 - After A55 proves N.C. low pressure switch S87 and N.C. high pressure switch S4, compressor contactor K1 is energized. K1 contactor energizes FL1 filter board, T61 transformer, and A192 compressor inverter. A192 compressor inverter powers compressor B1. A55 varies the operating hz of compressor B1 based on Y1/Y2 thermostat inputs and RT42, RT44, RT46, and RT48 temperature sensors.
- 2 - After proving N.C. low pressure switch S88 and N.C. high pressure switch S7, A55 stages compressor B2 on/off as needed based on Y1/Y2 thermostat inputs and RT43, RT45, RT47, and RT49 temperature sensors by energizing/deenergizing K2.
- 3 - Both condenser fans B4 and B5 operate when one or both compressors are operating. B4 and B5 modulate RPM to follow B1+B2 compressor load.

## DIRECT DRIVE BLOWER SEQUENCE OF OPERATION / TROUBLESHOOTING

### Blower Operation:

- 1 - Line voltage is routed to B3 blower motor through TB2 terminal strip, TB13 terminal strip, and J/P48 terminals 1, 2 and 3.
- 2 - B3 blower motor runs internal diagnostics to check for proper temperature, voltage, etc. (KL2-2 and -3). This process takes approximately 10 seconds. Refer to the Failure Handling/Troubleshooting section.
- 3 - A55 Unit Controller receives a thermostat demand. After A55 proves (P259-7 and -6) that B3 blower motor internal relay (KL2-2 and -3) is closed, B3 blower motor is energized (0-10VDC from P259-4 to KL3-4). B3 blower motor controls are grounded through KL2-2 and -3 to A55 P259-6.
- 4 - If configured, A55 checks S52 blower proving switch to make sure it closes within 16 seconds of the 0-10VDC signal being sent to B3 blower motor.

### Blower Fault Sequence Direct Drive Motor - No S52:

- 1 - Line voltage is provided to B3 blower motor.
- 2 - After 10 seconds, the B3 blower motor internal relay does not close.
- 3 - Alarm 186 is set by the A55 Unit Controller, de-energizing unit. If one of the "Error" failures listed in table NO TAG occurs ("Warning" failures will not set Alarm 186), service is required. Refer to the Failure Handling/Troubleshooting section.
- 4 - If B3 blower motor internal relay closes continue to next step.
- 5 - A55 sends 0-10VDC signal to B3 blower motor.
- 6 - During B3 blower motor operation, the internal motor relay opens.
- 7 - Alarm 186 is set by A55 and de-energizes the unit. Service is required. Refer to the Failure Handling/Troubleshooting section.

### Blower Fault Sequence Direct Drive Motor - With S52 (If Configured):

- 1 - A55 Unit Controller sends 0-10VDC signal to B3 blower motor.
- 2 - After 16 seconds, if S52 blower proving switch remains open, A55 will remove 0-10VDC signal for 5 minutes.
- 3 - A55 sends 0-10VDC signal to B3 blower motor.
- 4 - After 16 seconds, if S52 blower proving switch remains open, A55 will remove 0-10VDC signal for another 5 minutes.
- 5 - After the third try, A55 will de-energize the unit. Service is required.

### Failure Handling/Troubleshooting:

- 1 - Follow TABLE 7 to troubleshoot possible failures that would cause Alarm 186 to set.
- 2 - BEFORE DETERMINING THAT THE BLOWER ASSEMBLY HAS FAILED, use the A55 Unit Controller to clear delays and operate the blower.
- 3 - Main Menu > Service > Offline > Clear Delays > Yes > Save
- 4 - Main Menu > Service > Test > Blower
- 5 - Observe if the blower operates or if Alarm 186 sets again.
- 6 - If blower does not operate and Alarm 186 is set again, blower assembly must be replaced.
- 7 - If blower assembly does operate, wait a minimum of 30 minutes to ensure Alarm 186 is not set again.

LGM092-150 Y VOLT DIAGRAM

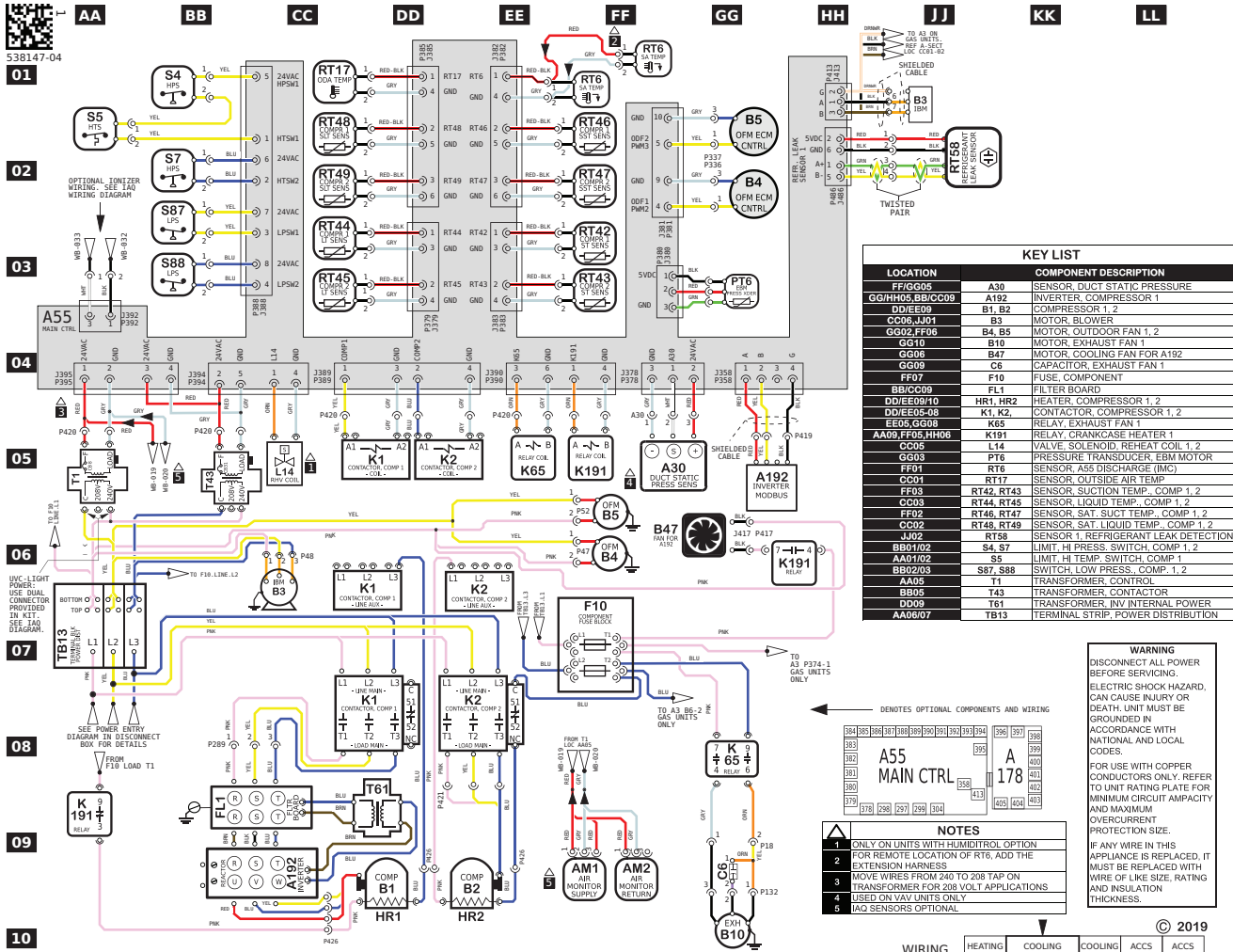

**KEY LIST**

LOCATION	COMPONENT DESCRIPTION
FF/GG05	A30 SENSOR, DUCT STATIC PRESSURE
GG/HH05, BB/CC09	A192 INVERTER, COMPRESSOR 1
DD/EE09	B1, B2 COMPRESSOR 1, 2
CC09, JJ01	B5 MOTOR, BLOWER
GG02, FF08	B4, B5 MOTOR, OUTDOOR FAN 1, 2
GG10	B10 MOTOR, EXHAUST FAN 1
GG08	B47 MOTOR, COOLING FAN FOR A192
GG09	C6 CAPACITOR, EXHAUST FAN 1
FF07	F10 FUSE, COMPONENT
BB/CC09	FL1 FILTER BOARD
DD/EE09/10	HR1, HR2 HEATER, COMPRESSOR 1, 2
DD/EE05-08	K1, K2 CONTACTOR, COMPRESSOR 1, 2
EE05, GG08	K65 RELAY, EXHAUST FAN 1
AA09, FF05, HH06	K191 RELAY, CRANKCASE HEATER 1
CC05	L14 VALVE, SOLENOID, REHEAT COIL 1, 2
PT6	PRESSURE TRANSDUCER, ECM MOTOR
FF01	RT6 SENSOR, A55 DISCHARGE (IMC)
CC01	RT17 SENSOR, OUTSIDE AIR TEMP
FF03	RT42, RT43 SENSOR, SUCTION TEMP, COMP 1, 2
CC03	RT44, RT45 SENSOR, LIQUID TEMP, COMP 1, 2
FF02	RT46, RT47 SENSOR, SAT. SUCT TEMP, COMP 1, 2
CC02	RT48, RT49 SENSOR, SAT. LIQUID TEMP, COMP 1, 2
JJ02	RT58 SENSOR 1, REFRIGERANT LEAK DETECTION
BB01/02	S4, S7 LIMIT, HI PRESS. SWITCH, COMP 1, 2
AA01/02	S5 LIMIT, HI TEMP. SWITCH, COMP 1
BB02/03	S87, S88 SWITCH, LOW PRESS., COMP. 1, 2
AA05	T1 TRANSFORMER, CONTROL
BB05	T43 TRANSFORMER, CONTACTOR
DD09	T61 TRANSFORMER, INV INTERNAL POWER
AA06/07	TB13 TERMINAL STRIP, POWER DISTRIBUTION

**WARNING**  
DISCONNECT ALL POWER BEFORE SERVICING. ELECTRIC SHOCK HAZARD. CAN CAUSE INJURY OR DEATH. UNIT MUST BE GROUNDED IN ACCORDANCE WITH NATIONAL AND LOCAL CODES. FOR USE WITH COPPER CONDUCTORS ONLY. REFER TO UNIT RATING PLATE FOR MINIMUM CIRCUIT AMPACITY AND MAXIMUM OVERCURRENT PROTECTION SIZE. IF ANY WIRE IN THIS APPLIANCE IS REPLACED, IT MUST BE REPLACED WITH WIRE OF LIKE SIZE, RATING AND INSULATION THICKNESS.

← DENOTES OPTIONAL COMPONENTS AND WIRING

**A55 MAIN CTRL**

**A 178**

**NOTES**

- 1 ONLY ON UNITS WITH HUMIDITROL OPTION
- 2 FOR REMOTE LOCATION OF RT6, ADD THE EXTENSION HARNESS
- 3 MOVE WIRES FROM 040 TO 208 TAP ON TRANSFORMER FOR 208 VOLT APPLICATIONS
- 4 USED ON VAV UNITS ONLY
- 5 IAQ SENSORS OPTIONAL

**WIRING DIAGRAM FLOW**

HEATING SECTION A	COOLING SECTION B	COOLING SECTION B3/S	ACCS SECTION C	ACCS SECTION D
-------------------	-------------------	----------------------	----------------	----------------

Product: LCM, LGM 092-150U - Y VOLT  
Cooling Diagram with Higher SCCR

Voltage: 208-230/3/60 (Y)  
Supersedes: XXXXX-XX Form No: 538147-04 Rev: 1

REV	EC NO.	DATE	BY	APVD	REVISION NOTE
---	CN-012081C	04-29-2024	FEP	MCF	ORIGINATED AT PDSR CARROLLTON, TX
001	CN-012081W	09-19-2024	FEP	FXV	A) UPDATED P18 CONNECTORS FROM 3 & 4 TO 1 & 2 B) REMOVED L43 REACTOR

10x12 CUT SIZE

LGM092-150 G & J VOLT DIAGRAM

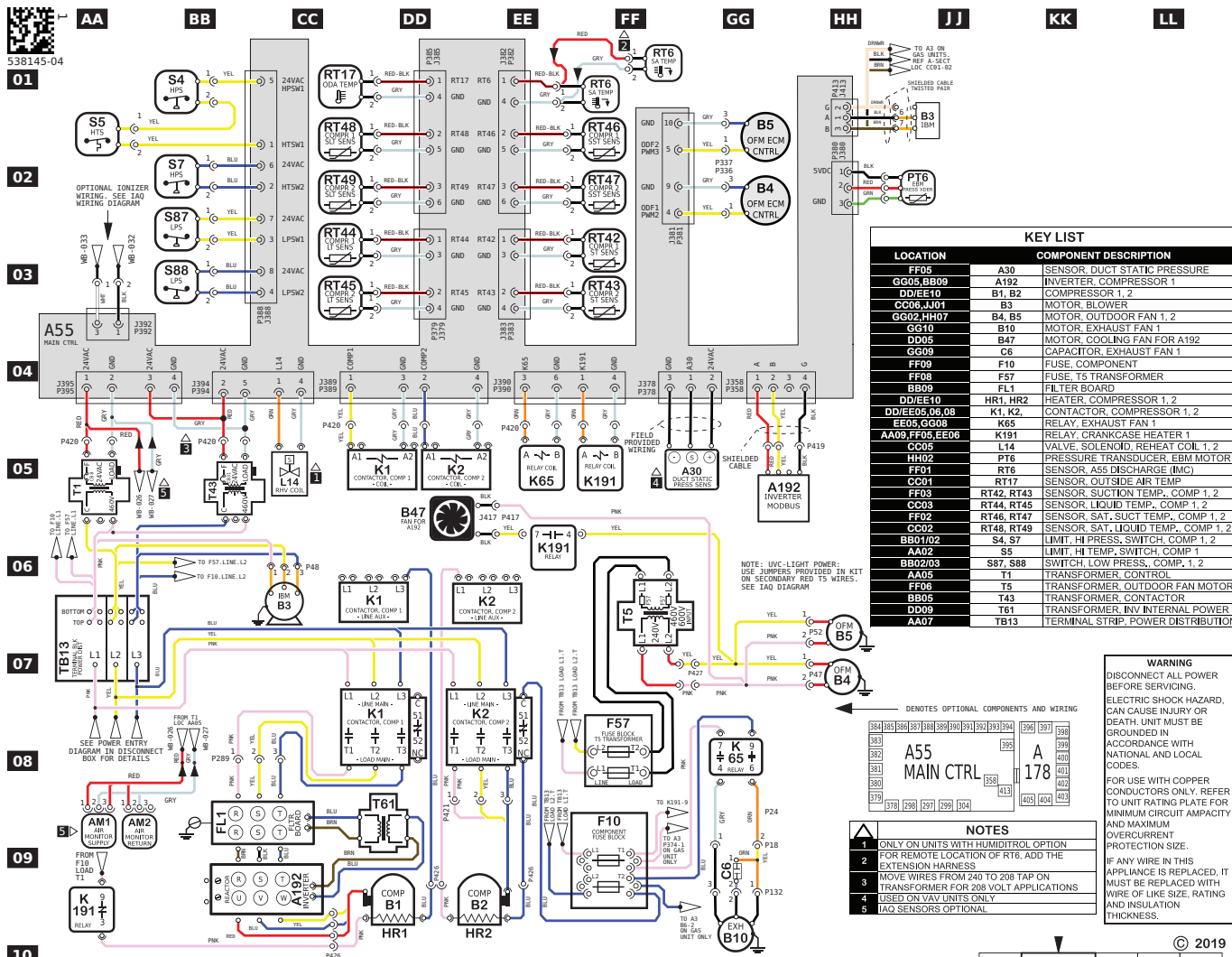

KEY LIST		
LOCATION		COMPONENT DESCRIPTION
FF05	A30	SENSOR, DUCT STATIC PRESSURE
GG05, BB09	A192	INVERTER, COMPRESSOR 1
DD/EE10	B1, B2	COMPRESSOR 1, 2
CC05, JJ01	B3	MOTOR, BLOWER
GG02, HH07	B4, B5	MOTOR, OUTDOOR FAN 1, 2
GG10	B10	MOTOR, EXHAUST FAN 1
DD05	B47	MOTOR, COOLING FAN FOR A192
CC09	C6	CAPACITOR, EXHAUST FAN 1
FF09	F10	FUSE, COMPONENT
FF08	F57	FUSE, T5 TRANSFORMER
BB09	FL1	FILTER BOARD
DD/EE10	HR1, HR2	HEATER, COMPRESSOR 1, 2
DD/EE05, 06, 08	K1, K2	CONTACTOR, COMPRESSOR 1, 2
EE05, CC09	K65	RELAY, EXHAUST FAN 1
AA02, FF05, EE06	K191	RELAY, CRANKCASE HEATER 1
CC05	L14	VALVE, SOLENOID, REHEAT COIL 1, 2
HH02	PT6	PRESSURE TRANSDUCER, EBM MOTOR
FF01	RT6	SENSOR, A55 DISCHARGE (IMC)
CC01	RT17	SENSOR, OUTSIDE AIR TEMP
FF03	RT42, RT43	SENSOR, SUCTION TEMP., COMP 1, 2
CC03	RT44, RT45	SENSOR, LIQUID TEMP., COMP 1, 2
FF02	RT46, RT47	SENSOR, SAT. SUCT TEMP., COMP 1, 2
CC02	RT48, RT49	SENSOR, SAT. LIQUID TEMP., COMP 1, 2
BB01/02	S4, S7	LIMIT, HI PRESS, SWITCH, COMP 1, 2
AA02	S5	LIMIT, HI TEMP, SWITCH, COMP 1
BB02/03	S87, S88	SWITCH, LOW PRESS., COMP, 1, 2
AA05	T1	TRANSFORMER, CONTROL
FF06	T5	TRANSFORMER, OUTDOOR FAN MOTOR
BB05	T43	TRANSFORMER, CONTACTOR
DD09	T61	TRANSFORMER, INV INTERNAL POWER
AA07	TB13	TERMINAL STRIP, POWER DISTRIBUTION

**WARNING**  
 DISCONNECT ALL POWER BEFORE SERVICING.  
 ELECTRIC SHOCK HAZARD. CAN CAUSE INJURY OR DEATH. UNIT MUST BE GROUNDED IN ACCORDANCE WITH NATIONAL AND LOCAL CODES.  
 FOR USE WITH COPPER CONDUCTORS ONLY. REFER TO UNIT RATING PLATE FOR MINIMUM CIRCUIT AMPACITY AND MAXIMUM OVERCURRENT PROTECTION SIZE.  
 IF ANY WIRE IN THIS APPLIANCE IS REPLACED, IT MUST BE REPLACED WITH WIRE OF LIKE SIZE, RATING AND INSULATION THICKNESS.

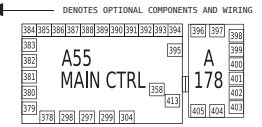

**NOTES**

- ONLY ON UNITS WITH HUMIDITROL OPTION
- FOR REMOTE LOCATION OF RT6, ADD THE EXTENSION HARNESS
- MOVE WIRES FROM 240 TO 208 TAP ON TRANSFORMER FOR 208 VOLT APPLICATIONS
- USED ON VAL UNITS ONLY
- IAQ SENSORS OPTIONAL

Product: LCM, LGM 092U, 102U, 120U & 150U - G & J VOLT  
 Cooling Diagram with Higher SCCR

Voltage: 460/3/60 (G), 575/3/60 (J)  
 Supersedes: 538145-02 Form No: 538145-04 Rev: 1

WIRING DIAGRAM FLOW

HEATING SECTION A	COOLING SECTION B	COOLING SECTION B3	ACCS SECTION C	ACCS SECTION D

© 2019

REV	EC NO.	DATE	BY	APVD	REVISION NOTE
---	CN-012081S	07-17-2024	FEP	MCF	ORIGINATED AT PD&R CARROLLTON, TX.
001	CN-012081W	09-19-2024	FEP	FXY	A) UPDATED P18 CONNECTORS 3 & 4 TO 1 & 2 B) REMOVED L43

## X-Decommissioning

Before carrying out this procedure, it is essential that the technician is completely familiar with the equipment and all its detail. It is recommended good practice that all refrigerants are recovered safely. Prior to the task being carried out, an oil and refrigerant sample shall be taken in case analysis is required prior to re-use of recovered refrigerant. It is essential that electrical power is available before the task is commenced.

Steps to ensure this are:

- Become familiar with the equipment and its operation,
- Isolate the system electrically,
- Ensure that before attempting the procedure that mechanical handling equipment is available, if required, for handling refrigerant cylinders, and that all personal protective equipment is available and being used correctly while the recovery process is supervised at all times by a competent person and that the recovery equipment and cylinders conform to the appropriate standards.

Additionally, pump down refrigerant system, if possible, and if a vacuum is not possible, make a manifold so that refrigerant can be removed from various parts of the system. Make sure that cylinders are situated on the scales before recovery takes place. Start the recovery machine and operate in accordance with instructions. Do not overfill cylinders (no more than 80 % volume liquid charge). Do not exceed the maximum working pressure of the cylinder, even temporarily. When the cylinders have been filled correctly and the process completed, make sure that the cylinders and the equipment are removed from site promptly and all isolation valves on the equipment are closed off. Recovered refrigerant shall not be charged into another refrigerating system unless it has been cleaned and checked.

Equipment shall be labeled stating that it has been decommissioned and emptied of refrigerant. The label shall be dated and signed. For appliances containing flammable refrigerants, ensure that there are labels on the equipment stating the equipment contains flammable refrigerant.

Under no circumstances shall potential sources of ignition be used in the searching for or detection of refrigerant leaks. A halide torch (or any other detector using a naked flame) shall not be used.

Electronic leak detectors may be used to detect refrigerant leaks but, in the case of flammable refrigerants, the sensitivity may not be adequate, or may need re-calibration. (Detection equipment shall be calibrated in a refrigerant-free area.) Ensure that the detector is not a potential source of ignition and is suitable for the refrigerant used. Leak detection equipment shall be set at a percentage of the LFL of the refrigerant and shall be calibrated to the refrigerant employed, and the appropriate percentage of gas (25 % maximum) is confirmed. Leak detection fluids are also suitable for use with most refrigerants but the use of detergents containing chlorine shall be avoided as the chlorine may react with the refrigerant and corrode the copper pipe-work. If a leak is suspected, all naked flames shall be removed/extinguished. If a leakage of refrigerant is found which requires brazing, all of the refrigerant shall be recovered from the system, or isolated (by means of shut-off valves) in a part of the system remote from the leak.

When breaking into the refrigerant circuit to make repairs – or for any other purpose – conventional procedures shall be used. However, for flammable refrigerants it is important that best practice be followed, since flammability is a consideration. The following procedure shall be adhered to:

- Safely remove refrigerant following local and national regulations,
- Evacuate the circuit,
- Purge the circuit with inert gas,
- Evacuate,
- Purge with inert gas,
- Open the circuit.

The refrigerant charge shall be recovered into the correct recovery cylinders if venting is not allowed by local and national codes. For appliances containing flammable refrigerants, the system shall be purged with oxygen-free nitrogen to render the appliance safe for flammable refrigerants. This process might need to be repeated several times. Compressed air or oxygen shall not be used for purging refrigerant systems. Refrigerant purging shall be achieved by breaking the vacuum in the system with oxygen-free nitrogen and continuing to fill until the working pressure is achieved, then venting to atmosphere, and finally pulling down to a vacuum. This process shall be repeated until no refrigerant is within the system. When the final oxygen-free nitrogen charge is used, the system shall be vented down to atmospheric pressure to enable work to take place. Ensure that the outlet for the vacuum pump is not close to any potential ignition sources and that ventilation is available.