

EL195UHNE(K)

ELITE® SERIES

Upflow / Horizontal | Constant Torque Blower | Refrigerant Detection | 60Hz



RESIDENTIAL
PRODUCT SPECIFICATIONS (EHB)

AFUE - 95%

Meets NOx Limit of 14 ng/J

Input - 40,000 to 100,000 Btuh

Nominal Add-on Cooling - 1 to 5 Tons



ELITE® SERIES



QUALIFIED ONLY IN

U.S. SOUTH: AL, AZ, AR, CA, DC, DE, FL, GA, HI, KY, LA, MD, MS, NV, NM, NC, OK, SC, TN, TX, VA



■ QUALIFIED

MODEL NUMBER IDENTIFICATION

EL 1 95 UH 060 N E 36 B K

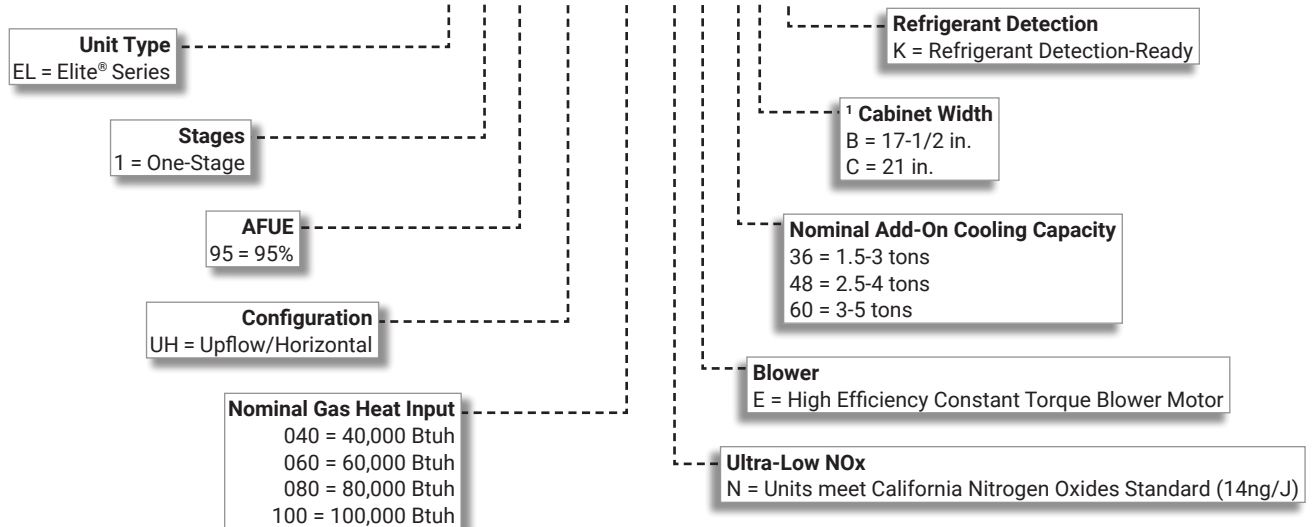

¹ Indoor coils with the same letter designation physically matches the furnace.

FEATURE HIGHLIGHTS

1. Heat Exchanger Assembly
2. Secondary Heat Exchanger
3. SureLight® Hot Surface Ignitor
4. Modulating Gas Control Valve
5. Combustion Air Inducer
6. Thermal Switch
7. SureLight® Integrated Furnace Control
8. Constant Torque Direct Drive Blower
9. Insulated Cabinet
10. Safety Interlock Switch
11. Gas Piping And Electrical Inlets

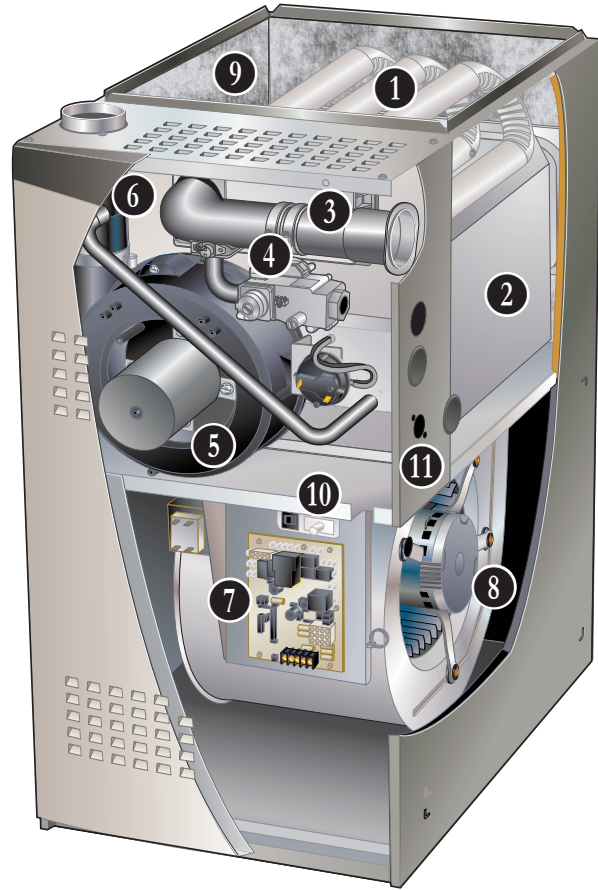

NOTE - EL195UHNE 40K AND 100K INPUT FURNACES ARE NATURAL GAS ONLY!
NOTE - NOT AVAILABLE IN ALL AREAS!
CONTACT YOUR NEAREST LENNOX SALES OFFICE FOR DETAILS.

CONTENTS

Approvals And Warranty	3
Blower Data	16
Control Options	9
Dimensions	18
- Furnace/Coil Combined Dimensions	24
- Optional Accessories	20
- Optional Accessories - Venting.	21
- Unit - Horizontal Position	19
- Unit - Upflow Position	18
Features	3
Gas Heat Accessories	12
High Altitude Operation.	13
Indoor Air Quality Product Options	8
Installation Clearances	15
Model Number Identification.	1
Optional Accessories - Order Separately	12
Specifications	11
Vent Lengths - Uninsulated Exhaust Pipe In Unconditioned Space	13

APPROVALS AND WARRANTY

APPROVALS

- AHRI Certified
- CSA International Certified
- Tested and rated according to US DOE test procedures and FTC labeling regulations
- Units are approved for installations from 0 - 4500 ft.
- ENERGY STAR® units are certified only in the U.S. South in certain states and are designed to use less energy, help save money on utility bills, and help protect the environment
- ISO 9001 Registered Manufacturing Quality System
- Blower data from unit tests conducted in Lennox Laboratory air test chamber
- All models meet UL 60335-2-40 Refrigerant Detector Requirements

NOTE - This furnace has not been CSA International design certified for installation in mobile homes, recreational vehicles, or outdoors.

California Only

- These furnaces **meet** the South Coast Air Quality Management District (SCAQMD) Rule 1111 and San Joaquin Valley Air Pollution Control District (SJVAPCD) Rule 4905 NOx emission limit (14 ng/J) and can be installed within the SCAQMD, SJVAPCD and Bay area

WARRANTY

- Heat Exchanger:
 - Limited lifetime (twenty year transferable) in residential applications
 - Limited ten years in non-residential applications
- All other covered components:
 - Limited five years in residential installations
 - Limited one year in non-residential installations

NOTE - Refer to Lennox® Basic Limited Warranty at www.Lennox.com for additional details.

FEATURES

APPLICATIONS

- Input capacities of 40,000, 60,000, 80,000 and 100,000 Btuh
- Energy efficiency (AFUE) - 95%
- Upflow, horizontal-left or horizontal-right applications
- Utility room, alcove, closet, crawl space, basement or attic installation
- Lennox add-on indoor coils, high-efficiency air cleaners and humidifiers can easily be added to furnace
- Shipped factory assembled with all controls installed and wired
- Removable bottom seal panel shipped in place for side return air is easily removed for bottom/end return air applications
- Each unit factory test operated to ensure proper operation

HEATING SYSTEM

- 1 Heat Exchanger Assembly**
 - Heavy-gauge, aluminized steel heat exchanger
 - Tubular type design
 - Designed for normal expansion and contraction with maximum efficiency and minimum resistance to air flow
- 2** • Secondary heat exchanger condenser coil constructed of aluminum fins fitted to stainless steel tubes
 - Coil is factory tested for leaks

- Condensate drain header box assembly located on front of coil
- Laboratory life cycle tested in excess of industry standards
- Compact size of complete heat exchanger assembly permits low overall design of furnace cabinet

Header Box

- Header box on end of condenser coil collects flue condensate for disposal through condensate drains
- Drains are located on each side of the cabinet for easy field installation of condensate drain trap
- Only one drain is used, the other drain is sealed
- Condensate drain trap is included for field installation

Flue Condensate Trap Assembly

- Field installed outside the conditioned air stream
- Assembly can be mounted on either side of cabinet in upflow applications
- Assembly is mounted below the cabinet in horizontal applications
- Can also be mounted remotely (up to 5 ft. away) from unit
- See Installation Instructions
- 90° street elbow furnished for ease of drain trap installation
- Drain connection can be made with field provided PVC pipe, PVC coupling, or vinyl tubing with hose clamp
- Drain cap on trap allows easy cleaning and winterizing

FEATURES

HEATING SYSTEM (continued)

- 3** SureLight® Hot Surface Ignitor
- Tough, reliable, long-life, trouble-free performance
 - Silicon nitride ignitor
 - Cemented to steatite block for protection against current leakage
 - Ignition leads are constructed of nickel-plated copper and are enclosed in high temperature Teflon® insulation for dependable operation

- 4** Modulating Gas Control Valve
- 24 volt redundant combination modulating gas control valve combines manual shut off switch (On-Off), automatic electric valve (dual) and gas pressure regulation into a compact combination control

- 5** Combustion Air Inducer
- Shaded pole heavy duty blower prepurges heat exchanger and safely vents flue products
 - Operates only during heating cycle

Pressure Switch

- Proves Combustion Air Inducer operation before allowing gas valve to open

- 6** Thermal Switch
- Factory installed on air/fuel intake assembly
 - Provides protection from abnormal operating conditions
 - Automatic reset

Limit Control

- Primary limit is accurately located on vestibule panel on all units
- Automatic reset

Optional Accessories

Natural Gas to LPG/Propane Conversion Kit (60K and 80K Input Furnaces Only)

- Required for field changeover from natural gas to LPG/Propane
- Includes gas and air orifices

Muffler (US Only)

- Significantly reduces outdoor operating sound levels
- Installed vertically in the exhaust piping
- See Optional Accessory Dimension Drawing

NOTE - Two-inch muffler is optional for the 100 input model with a maximum vent pipe length of up to 29 ft.
Three-inch diameter muffler is optional for 100 input model.

NOTE - Three-inch muffler is optional for the 100 input model with a minimum vent pipe length of 30 ft.

DIRECT VENT / NON-DIRECT VENT SEALED COMBUSTION SYSTEM

- Furnace features a “sealed combustion” system and can be installed in either Direct Vent or Non-Direct applications
- In Direct Vent applications, combustion air is supplied from outdoors and flue gases are discharged outdoors
- In Non-Direct Vent applications, combustion air is supplied from indoors and flue gases are discharged outdoors

NOTE - Lennox has approved the use of DuraVent® PolyPro®, Centrotherm InnoFlue® and ECCO Polypropylene Vent™ manufactured vent pipe and terminations as an alternative to PVC vent pipe. Must be ordered separately. Tested and listed to the ULC S636 standard in Canada.

NOTE - The polypropylene venting system must follow the uninsulated and unconditioned space vent lengths listed in the table on Page 13. Refer to the Installation Instructions for additional details.

Optional Accessories

Flue Coupling

- Assists with exhaust flue piping connection and servicing
- Includes flexible one 2-inch rubber coupling and two adjustable bands
- Approved for all Lennox 90% furnaces

Vent Termination Kits

- Facilitates installation of combustion air intake pipe and flue exhaust pipe
- Refer to venting table in this bulletin to determine pipe size needed and proper termination kit required
- See Optional Accessories table and dimension drawings

Concentric Termination Kit - Direct Vent Applications

- 2 or 3 inch kit contains concentric termination assembly, reducer bushing and 45° elbow
- 2 inch kit for -070 model contains an outdoor exhaust accelerator
- Kit requires single hole penetration of roof or wall for installation
- Roof Termination Flashing Kit available for use 2 inch Kits
- CSA certified

Flush-Mount Termination Kit

- Kit contains flush-mount termination, accelerator, mounting template and hardware
- Kit may be used with 2, 2-1/2, or 3 inch pipe

FEATURES

DIRECT VENT / NON-DIRECT VENT SEALED COMBUSTION SYSTEM (continued)

Optional Accessories (continued)

Wall Assembly Termination Kits

Close Couple (US Only) - Direct Vent Applications

- 2 or 3 inch kit consists of close-couple, side-by-side PVC piping with galvanized steel wall cover plate for
- Seals and isolates intake and exhaust piping penetration of wall
- Piping spacing and length is sized for proper wall installations
- CSA certified

Close Couple WTK (Canada Only) - Direct Vent Applications

- 2 or 3 inch kit contains one insulated faceplate, one insulated exhaust pipe, elbow and fittings

NOTE - Maintain a maximum of 6 inches between the inlet and outlet openings in the installation of the pipes.

Roof Termination Flashing Kit

- For vertical venting through a roof
- 2 or 3 inch kit contains two neoprene rubber roof flashings
- Vent pipe and insulation not furnished
- Flashing Kit can also be used with Concentric Vent Termination Kits used in vertical venting rooftop applications

CONTROLS

7 SureLight® Integrated Furnace Control

- Contains all necessary controls and relays to operate furnace
- Combustion air inducer is operated by the integrated furnace control. Prior to ignition, a pre-purge cycle for 15 seconds is initiated
- After the main burners are turned off, a post-purge cycle for 5 seconds is run
- Flame sensor assures safe and reliable operation
- Should loss of flame occur, the integrated furnace control will initiate 4 re-attempts at ignition before locking out unit operation for 60 minutes
- Watchguard type circuit automatically resets ignition controls after one hour of continuous thermostat demand after unit lockout, eliminating nuisance calls for service
- Display LED - Seven segment LED displays numeric information related to diagnostics as well as system operation and status
 - Diagnostic codes are held in non-volatile memory, immune from power interruptions
 - Holds up to ten diagnostic codes in order of occurrence for recall on demand
 - Port on blower door allows for easy viewing
- Fan control consists of adjustable blower timed-off delay (60, 90, 120, 180 seconds - factory setting 120 seconds) and fixed blower timed-on delay (30 seconds heating, 2 seconds cooling)

- For air-conditioning applications, blower is automatically energized on thermostat demand for cooling
- Two accessory terminals furnished for additional power supply requirements for 120 volt (less than 1 amp) power humidifiers and powered air cleaners
- One additional terminal is furnished for power supply requirements for 24V (less than 0.5 amp) low voltage accessories
- Ignition control has a single red LED to indicate status

Twinning

- Terminal furnished on furnace control for twinning two furnaces together

24 Volt Transformer (40VA)

- Furnished and factory installed on outside of control box
- Circuit breaker (furnished) is wired in series

Field Wiring Make-Up Box

- Furnished for line voltage wiring
- Factory installed internally on left side of furnace
- Box may be installed internally on right side of furnace

Refrigeration Detection System (RDS)

(Part of the SureLight® Integrated Furnace Control)

- Complies with UL 60335-2-40 approved standard
- Required for all systems using R-454B refrigerant
- Plug-in connection to the RDS Coil Sensor
- Supports up to two RDS Coil Sensors (factory setting)
- Used as an interface between indoor unit and thermostat to control system
- Ensures safe operation for systems equipped with R-454B refrigerant
- If R-454B refrigerant is detected, the refrigerant detection system will stop compressor and/or heating operation and operate the blower to reduce concentrations in the conditioned space
- Once safe levels are reached the HVAC system will resume normal operation
- Low GWP test button for troubleshooting
- Alarm/Zone relay interface can trigger an external alarm if R-454B refrigerant is detected and open all zone dampers (if part of a zoning system) if R-454B refrigerant is detected
- Power is disabled to non-communicating thermostats to prevent demand if R-454B refrigerant is detected
- On system start-up blower will run for five minutes and any thermostat demands are disabled

FEATURES

CONTROLS (Continued)

Optional Accessories

Thermostat

- Thermostat is not furnished with unit
- See Page 9

Transformer (75VA)

- Recommended when furnace is used with zoning or dual-fuel systems and other 24V accessories requiring a higher VA rating
- Circuit breaker (furnished) is wired in series
- Replaces the standard 40VA transformer

BLOWER

- Direct drive blower
- Statically and dynamically balanced
- Resiliently mounted
- Blower assembly easily removed for servicing

8 Power Saver™ Constant Torque Blower Motor

- DC Brushless Motor
- High Efficiency Constant Torque
- ECM (Electronically Commutated Motor)
- Motor is programmed to provide constant torque at each of the selectable speeds
- Motor is controlled by the Integrated Furnace Control
- Blower speeds are easily changed on the integrated furnace control. See Blower Data tables

CABINET

- Low-profile, narrow width allows easy installation
- Heavy-gauge, cold rolled steel construction
- Pre-painted cabinet finish
- Flanges provided on supply air opening for ease of plenum connection or alignment with indoor coil
- 9 • Insulated with foil faced insulation on sides and back of heating compartment and mat faced insulation in blower compartment
- Sealed blower compartment
- Inner blower compartment access panel seals blower compartment from air leakage
- Cabinet door can be removed without any tools
- Complete service access
- 10 • Safety interlock switch automatically shuts off power to unit when blower compartment access door is removed
- 11 • Gas piping inlet is provided on right side of cabinet
- Electrical inlets are provided on both sides of cabinet.

Bottom/Side Return Air Entry

- Upflow/horizontal with bottom return air entry:
 - Remove furnished bottom seal panel from cabinet
- Upflow only with side return-air entry:
 - Corners are marked on either side of cabinet for return air cut-out
- See dimension drawings

NOTE - 60C size units that require air volumes over 1800 cfm must have one of the following:

- Single side return air and Optional Return Air Base with transition that must accommodate required 20 x 25 x 1 inch air filter to maintain proper velocity
- Bottom return air
- Return air from both sides
- Bottom and one side return air
- See Blower Performance Tables for additional information

Coil Match-Up

- All furnaces exactly match Lennox cased upflow indoor coils and horizontal indoor coils with same letter designation (A, B, C, D) in model number
- No adaptor required
- Engaging holes furnished on cabinet for alignment
- Lennox uncased coils match furnaces without any overhang but require an optional adaptor base or field fabricated transition to match furnace opening
- See coil bulletin for additional information

Low Leakage Cabinet

- All models have less than 2% air leakage
- Meets ANSI/ASHRAE Standard 193-2010 "Method of Test for Determining the Air Tightness of HVAC Equipment"

FEATURES

CABINET (continued)

Optional Accessories

Condensate Drain Heat Cable Kits

- Self-limiting wattage heat cable prevents condensate drain from freezing in unconditioned areas
- Available in 6 or 24 ft. lengths

Horizontal Suspension Kit

- Provides suspension of unit and indoor coil in horizontal applications
- Allows complete service access
- Consists of corner mounted hanging brackets with vibration isolators, return air end support rail and hardware for assembly
- Metal hanging straps must be field provided

Crawl Space Vent Drain Kit

- Allows venting through a crawl space for upflow and horizontal applications
- Kit for Canada is certified to ULC S636
- Includes 2 or 3 inch sanitary tee, 2 inch PVC assembly, PVC boot and clamp
- Kit for Canada is certified to ULC S636

Return Air Base

NOTE - On furnaces with side return air and condensate trap on the same side of the cabinet, a field fabricated transition or Return Air Base is required when using an IAQ product higher than 14-3/16 inches installed next to the unit and serviced from the front. IAQ products higher than 20 inches require a field fabricated transition.

NOTE - Must be used for 60C size models with air volumes over 1800 cfm in upflow applications when only one side return is required.

- Cabinet is shipped flat for easy field assembly
- Pre-painted steel to match the furnace
- See Dimension Drawing

High Performance Economizer (Commercial Applications Only)

- Designed for applications requiring outdoor air to be utilized in a commercial HVAC system
- Allows the entry of fresh outdoor air for free cooling, reducing the requirement for mechanical cooling
- Heavy gauge galvanized steel cabinet lined with thick fiberglass insulation
- Mixed air sensor, outdoor air sensor and 24VAC transformer furnished
- Approved for California Title 24 building standards. ASHRAE 90.1-2010 compliant
- See separate Product Specifications bulletin for additional information and available control and sensor options

FILTER (not furnished)

- Filter and provisions for external mounting must be field provided

Optional Accessories

Air Filter and Rack Kit for Horizontal Return Air (End) Applications

- Washable or vacuum cleanable polyurethane frame type filter and external end return air rack
- Rack has filter door for servicing
- Flanges on rack for duct connection
- Field installed
- See dimension drawing

Air Filter and Rack Kit for Upflow Side Return Air

NOTE - Not for use with Return Air Base

- Washable or vacuum cleanable polyurethane frame type filter and external side return air rack available for field installation
- Available in single and ten pack kits
- Rack has filter door for servicing
- Flanges on rack for duct connection
- Field installs on either side of unit cabinet
- See dimension drawing

INDOOR AIR QUALITY PRODUCT OPTIONS

Healthy Climate® PureAir® Air Purification System

- Filtration - The Carbon Clean 16® (MERV 16) media filter captures more than 95% of particles 0.3 microns and larger and more than 90% of particles 0.01 microns and larger
- Highest airflow performance and lowest pressure drop when compared to a leading brand.
- Long life filters up to 1 year



Healthy Climate® Media Air Cleaner

- High performance in a narrow 7 in. cabinet
- Available with MERV 11, 13, or 16 rated filters
- Multi-position heavy gauge steel cabinet will support furnace/coil or air handler and associated duct work
- Tool-less entry
- Tool-less assembly for quick installation



Healthy Climate® Whole Home In Duct Air Purifiers

- Compact Duct Mounted Design
- Effective against odors and VOC's
- Certified Ozone free
- UVC lamp and carbon cells



Healthy Climate® Ultraviolet Germicidal Lights

- Compact duct mounted design
- Single or dual applications
- Certified ozone free
- Effective against odors to help keep the system clean
- Safety Interlocks (Additional UVC Compliance Kit for UL 60335-2-40 is available for A2L applications)
- Low power consumption
- Available for 24V or 110/230V
- Up to 1340 microwatts /cm² output (dual lamp model)



NOTE - Please refer to the individual Product Specifications for these products for full information.

NOTE - Please refer to the individual Product Specifications for these products for full information.

CONTROL OPTIONS

E40 Smart Wi-Fi Thermostat

- 3 Htg.-2 Clg.
- 7-day, universal, programmable, touchscreen thermostat
- Controls dehumidification during cooling mode and humidification during heating mode
- Smooth Setback Recovery and compressor short-cycle protection
- One-Touch Away Mode, Smart Away™ (geo-fencing), equipment maintenance reminders and scheduling
- Smart home automation compatible with Amazon Alexa®, Google Assistant, Control4®, Building36® and Matter
- Lennox® Home App controls temperature, fan operation, set programs/schedules and set Away mode on a smartphone
- Lennox Smart Tech App allows the installer to commission the system and remotely turn the system on and off during setup or service call on a smartphone



M40 Smart Wi-Fi Thermostat

- 3 Htg.-2 Clg.
- 7-day, universal, programmable, touchscreen thermostat
- Smooth Setback Recovery and compressor short-cycle protection
- One-Touch Away Mode, Smart Away™ (geo-fencing), equipment maintenance reminders and scheduling
- Smart home automation compatible with Apple HomeKit™, Amazon Alexa®, Google Assistant and Matter
- Lennox® Home App controls temperature, fan operation, set programs/schedules and set Away mode on a smartphone
- Lennox Smart Tech App allows the installer to commission the system and remotely turn the system on and off during setup or service call on a smartphone



L40 Smart Wi-Fi Thermostat

- 2 Htg.-1 Clg.
- 7-day, universal, programmable, touchscreen thermostat
- Provides temperature control for gas, electric and heat pumps for single-stage heating or cooling systems (including dual-fuel operation)
- One-Touch Away Mode, Smart Away™ (geo-fencing), equipment maintenance reminders and scheduling
- Smooth Setback Recovery and compressor short-cycle protection
- Smart home automation compatible with Amazon Alexa®, Google Assistant, Control4®, Building36® and Matter
- Lennox® Home App controls temperature, fan operation, set programs/schedules and set Away mode on a smartphone
- Lennox Smart Tech App allows the installer to commission the system and remotely turn the system on and off during setup or service call on a smartphone



NOTE - Please refer to the individual Product Specifications for these products for full information.

INDOOR AIR QUALITY PRODUCT OPTIONS - ORDERING

NOTE - Refer to the individual Product Specifications documents for additional accessories and maintenance items.

Description	Dimensions	Furnace Width	Order Number
PureAir® S Air Purification System			
PCO3S-16-16	17-1/2 x 8-3/4 x 26-1/2	A/B/C	Y8904
PCO3S-20-16	21-1/8 x 8-3/4 x 26-1/2	C/D	Y8903
Healthy Climate® Media Air Cleaner			
HCC16-28 (Cabinet)	17-1/2 x 28-1/2 x 7	A/B/C	Y2920
HCC16-28 (Cabinet) 4-pack	17-1/2 x 28-1/2 x 7	---	Y2921
HCF16-16 (Filter) MERV 16	16 x 25 x 5	---	X6672
HCXF16-16 (Expandable Filter) MERV 16	16 x 25 x 5	---	X8306
HCF16-13 MERV 13	16 x 25 x 5	---	19L16
HCF16-11 (Filter) MERV 11	16 x 25 x 5	---	X6670
HCXF16-11 (Expandable Filter) MERV 11	16 x 25 x 5	---	X8303
HCC20-28 (Cabinet)	21 x 28-1/2 x 7	C/D	X6661
HCC20-28 (Cabinet) 4-pack	21 x 28-1/2 x 7	---	X7751
HCF20-16 (Filter) MERV 16	20 x 25 x 5	---	X6675
HCXF20-16 (Expandable Filter) MERV 16	20 x 25 x 5	---	X8307
HCF20-13 MERV 13	20 x 25 x 5	---	19L17
HCF20-11 (Filter) MERV 11	20 x 25 x 5	---	X6673
HCXF20-11 (Expandable Filter) MERV 11	20 x 25 x 5	---	X8304
Healthy Climate® Whole Home In Duct Air Purifiers			
HCWHAP1	8 x 7 x 16.5	---	23V99
Healthy Climate® Ultraviolet Germicidal Lights			
UVC-24V (24V) 17-1/2 in.	Ballast 4-3/4 x 2-1/4 x 2	---	X9423
UVC-41W-S (110/230V) 17-1/2 in.	Ballast 11-3/4 x 2-3/4 x 1-5/8	---	X9424
UVC-41W-D (110/230V) 17-1/2 in.	Ballast 11-3/4 x 2-3/4 x 1-5/8	---	X9425
CONTROLS - ORDERING			
E40 Smart Wi-Fi Thermostat	3-3/8 x 5-3/8 x 1	---	30L26
Lennox® Smart Room Sensor	4 x 5-1/2 x 3	---	22V25
Lennox® Smart Air Quality Monitor	3-5/8 x 4-3/8 x 1-3/8	---	21P02
Lennox® Wireless Extender	4 x 5-1/2 x 2-1/2	---	22V26
L40 Smart Wi-Fi Thermostat	2-13/16 x 2-13/16 x 1/4	---	27V51
M40 Smart Wi-Fi Thermostat	3-5/16 x 4-5/16 x 7/8	---	30L27
Thermostat Accessories			
¹ Discharge Air Temperature Sensor (For S40, E40)			88K38
² Remote Outdoor Air Temperature Sensor (For E40/L40) (For dual-fuel and Humiditrol®)			X2658

¹ Optional for service diagnostics (E40).

² Remote Outdoor Air Temperature Sensor is used with conventional (non-Lennox® Communicating) outdoor units (sensor is furnished with Lennox® Communicating outdoor units). Allows the thermostat to display outdoor temperature. Required in dual-fuel and Humiditrol® applications.

SPECIFICATIONS

Gas	Model	EL195UH040NE36BK	EL195UH060NE36BK
Heating Performance	¹ AFUE	95%	95%
	Input - Btuh	40,000	60,000
	Output - Btuh	39,000	58,000
	Temperature rise range - °F	30 - 60	35 - 65
	Gas Manifold Pressure (in. w.g.) Nat. Gas / LPG/Propane	3.5 / N/A	3.5 / 4.0
	High static - in. w.g.	0.5	0.5
Connections	Intake / Exhaust Pipe (PVC)	2 / 2	2 / 2
	Gas pipe size IPS	1/2	1/2
	Condensate Drain Trap (PVC pipe) - i.d.	3/4	3/4
	with furnished 90° street elbow	3/4 slip x 3/4 MIPT	3/4 slip x 3/4 MIPT
	with field supplied (PVC coupling) - o.d.	3/4 slip x 3/4 MPT	3/4 slip x 3/4 MPT
Indoor Blower	Wheel diameter x width - in.	10 x 8	10 x 8
	Motor Type	DC Brushless	DC Brushless
	Motor output - hp	1/2	1/2
	Tons of add-on cooling	1 - 2	1.5 - 3
	Air Volume Range - cfm	260 - 990	550 - 1380
Electrical Data	Voltage	120 volts - 60 hertz - 1 phase	
	Blower motor full load amps	6.4	6.4
	Maximum overcurrent protection	15	15
Shipping Data	lbs. - 1 package	122	128

NOTE - Filters and provisions for mounting are not furnished and must be field provided.

¹ Annual Fuel Utilization Efficiency based on DOE test procedures and according to FTC labeling regulations. Isolated combustion system rating for non-weatherized furnaces.

SPECIFICATIONS

Gas	Model	EL195UH080NE48CK	EL195UH100NE60CK
Heating Performance	¹ AFUE	95%	95%
	Input - Btuh	80,000	100,000
	Output - Btuh	78,000	97,000
	Temperature rise range - °F	40 - 70	45 - 75
	Gas Manifold Pressure (in. w.g.) Nat. Gas / LPG/Propane	3.5 / 4.0	3.5 / N/A
	High static - in. w.g.	0.5	0.5
Connections	Intake / Exhaust Pipe (PVC)	2 / 2	2 / 2
	Gas pipe size IPS	1/2	1/2
	Condensate Drain Trap (PVC pipe) - i.d.	3/4	3/4
	with furnished 90° street elbow	3/4 slip x 3/4 MIPT	3/4 slip x 3/4 MIPT
	with field supplied (PVC coupling) - o.d.	3/4 slip x 3/4 MPT	3/4 slip x 3/4 MPT
Indoor Blower	Wheel diameter x width - in.	10 x 10	11-1/2 x 10
	Motor Type	DC Brushless	DC Brushless
	Motor output - hp	3/4	1
	Tons of add-on cooling	2.5 - 4	3.5 - 5
	Air Volume Range - cfm	760 - 1740	1260 - 2405
Electrical Data	Voltage	120 volts - 60 hertz - 1 phase	
	Blower motor full load amps	9.3	12.3
	Maximum overcurrent protection	15	15
Shipping Data	lbs. - 1 package	148	157

NOTE - Filters and provisions for mounting are not furnished and must be field provided.

¹ Annual Fuel Utilization Efficiency based on DOE test procedures and according to FTC labeling regulations. Isolated combustion system rating for non-weatherized furnaces.

OPTIONAL ACCESSORIES - ORDER SEPARATELY

		"B" Width Models	"C" Width Models		
CABINET ACCESSORIES					
Horizontal Suspension Kit - Horizontal only		51W10	51W10		
Return Air Base - Upflow only		50W98	50W99		
High Performance Economizer (Commercial Only)		10U53	10U53		
CONDENSATE DRAIN KITS					
Condensate Drain Heat Cable	6 ft.	26K68	26K68		
	24 ft.	26K69	26K69		
Crawl Space Vent Drain Kit	US	51W18	51W18		
	Canada	15Z70	15Z70		
CONTROLS					
Blower Relay Kit (for two-stage outdoor units)		85W66	85W66		
Transformer (75VA)		27J32	27J32		
FILTER KITS					
1 Air Filter and Rack Kit	Horizontal (end)	Size of filter - in.			
		18 x 25 x 1	20 x 25 x 1		
	Side Return	Single	44J22	44J22	
		Ten Pack	66K63	66K63	
		Size of filter - in.	16 x 25 x 1		
TERMINATION KITS					
See Installation Instructions for specific venting information.					
Direct Vent	Concentric	US - 2 in.	71M80	69M29	
		3 in.	---	60L46	
		Canada - 2 in.	44W92	44W92	
		3 in.	---	44W93	
		Flush-Mount	US - 2, 2-1/2 or 3 in.	51W11	51W11
			Canada - 2, 2-1/2 or 3 in.	51W12	51W12
	Wall - Close Couple	US - 2 in.	22G44	---	
		3 in.	44J40	44J40	
	Wall - Close Couple WTK	Canada - 2 in.	30G28	---	
		3 in.	81J20	81J20	
	Roof Termination Flashing Kit (no vent pipe - 2 flashings)	2 in.	15F75	15F75	
		3 in.	44J41	44J41	
VENTING					
Flue Coupling	2 in.	17H92	17H92		

¹ Cleanable polyurethane frame type filter.

NOTE - Termination Kits (44W92, 44W93, 30G28, 51W12, 81J20) and Crawl Space Vent Drain Kit (15Z70) are certified to ULC S636 standard for use in Canada only.

GAS HEAT ACCESSORIES

Input	Natural Gas to LPG/Propane Kit
	0 - 7500 ft.
040	N/A
060	19K05
080	19K06
100	N/A

NOTE - Natural Gas to LPG/Propane Kit is not available for 40K and 100K Input furnaces.

HIGH ALTITUDE OPERATION

NOTE - Units may be installed at altitudes up to 7500 ft. above sea level.

OUTDOOR TERMINATION KIT USAGE

Input Size	Vent Pipe Diameter (in.)	Standard Terminations				Concentric Terminations			Muffler
		Flush Mount Kit	Wall Kit		Field Fabricated Exhaust Accelerator Size Required	Concentric Kit			
			2 inch	3 inch		1-1/2 inch	2 inch	3 inch	2 inch/ 3 inch
		51W11 (US) 4 51W12 (CA)	22G44 (US) 4 30G28 (CA)	44J40 (US) 4 81J20 (CA)		71M80 (US) 4 44W92 (CA)	69M29 (US) 4 44W92 (CA)	60L46 (US) 4 44W93 (CA)	15Y66 (US)/ 16A56 (US)
040	2	³ YES	YES	¹ YES	1-1/2 in.	² YES	---	---	YES
	3	³ YES	YES	¹ YES	1-1/2 in.	² YES	---	---	YES
060	2	³ YES	YES	¹ YES	1-1/2 in.	² YES	---	---	YES
	3	³ YES	YES	¹ YES	1-1/2 in.	² YES	---	---	YES
080	2	³ YES	---	YES	2 in.	---	YES	YES	YES
	3	³ YES	---	YES	2 in.	---	YES	YES	YES
100	2	YES	---	YES	2 in.	---	YES	YES	⁵ YES
	3	YES	---	YES	2 in.	---	YES	YES	⁵ YES

NOTE - Standard Terminations do not include any vent pipe or elbows external to the structure.

Any vent pipe or elbows external to the structure must be included in total vent length calculations. See Vent Length Tables.

¹ Requires field provided 1-1/2 in. outdoor exhaust accelerator.

² Concentric Kits **71M80** and **44W92** include 1-1/2 in. outdoor exhaust accelerator, required when used with 040 and 060 input models. Accelerator is not used with 080 or 100 input models.

³ Flush Mount Kit **51W11** and **51W12** includes 1-1/2 in. outdoor exhaust accelerator, required when used with 040, 060 and 080 input models. Accelerator is not used with 100 input models.

⁴ Termination Kits **30G28**, **44W92**, **44W93**, **51W12** and **81J20** are certified to ULC S636 standard for use in Canada only.

⁵ Two-inch diameter muffler **15Y66** is optional for 100 input model with a maximum vent pipe length of up to 29 ft.

Three-inch diameter muffler **16A56** is optional for 100 input model with a minimum vent pipe length of 30 ft.

VENT LENGTHS - UNINSULATED EXHAUST PIPE IN UNCONDITIONED SPACE

¹ Winter Design Temperatures	Vent Pipe Diameter	Unit Input Size							
		040		060		080		100	
		² Maximum Uninsulated Exhaust Vent Length (ft.)							
		PVC	³ PolyPro/ InnoFlue/ ECCO	PVC	³ PolyPro/ InnoFlue/ ECCO	PVC	³ PolyPro/ InnoFlue/ ECCO	PVC	³ PolyPro/ InnoFlue/ ECCO
32 to 21°F	2 in.	18	16	31	28	50	48	30	30
	3 in.	9	9	18	18	35	35	47	47
20 to 1°F	2 in.	9	8	18	16	32	29	30	30
	3 in.	N/A	N/A	8	8	19	19	26	26
0 to -20°F	2 in.	5	N/A	12	10	22	19	30	27
	3 in.	N/A	N/A	N/A	N/A	10	10	16	16

¹ Refer to 99% Minimum Design Temperature table provided in the current edition of the ASHRAE Handbook-Fundamentals.

² Maximum Equivalent Vent Length permitted is defined as Total Length (linear feet) of vent pipe, plus equivalent length (ft.) of fittings, plus equivalent length (ft.) of termination.

VENTING NOTES - Concentric Terminations are equivalent to 5 ft. of straight pipe and should be included when measuring total pipe length.

One 90° elbow is equivalent to 5 feet of straight vent pipe.

Two 45° elbows are equal to one 90° elbow.

One 45° elbow is equivalent to 2.5 feet of straight vent pipe.

³ PolyPro® poly-propylene vent pipe is a registered trademark of DuraVent®.

Innoflue® is a registered trademark of Centrotherm Eco Systems.

ECCO Polypropylene Vent™ is a registered trademark of ECCO Manufacturing™.

VENT LENGTHS

STANDARD TERMINATION AT ELEVATION 0 - 4500 FT.

Pipe Size		2 in.				3 in.			
Input		040	060	080	100	040	060	080	100
No. of 90 ELL	1	81	66	44	44	138	137	118	118
	2	76	61	39	39	133	132	113	113
	3	71	56	34	34	128	127	108	108
	4	66	51	29	29	123	122	103	103
	5	61	46	24	24	118	117	98	98
	6	56	41	19	19	113	112	93	93
	7	51	36	14	14	108	107	88	88
	8	46	31	N/A	N/A	103	102	83	83
	9	41	26	N/A	N/A	98	97	78	78
	10	36	21	N/A	N/A	93	92	73	73

STANDARD TERMINATION AT ELEVATION 4501 - 7500 FT.

Pipe Size		2 in.				3 in.			
Input		040	060	080	100	040	060	080	100
No. of 90 ELL	1	81	41	34	9	138	105	100	65
	2	76	36	29	N/A	133	100	95	60
	3	71	31	24	N/A	128	95	90	55
	4	66	26	19	N/A	123	90	85	50
	5	61	21	14	N/A	118	85	80	45
	6	56	16	9	N/A	113	80	75	40
	7	51	11	N/A	N/A	108	75	70	35
	8	46	N/A	N/A	N/A	103	70	65	30
	9	41	N/A	N/A	N/A	98	65	60	25
	10	36	N/A	N/A	N/A	93	60	55	20

CONCENTRIC TERMINATION AT ELEVATION 0 - 4500 FT.

Pipe Size		2 in.				3 in.			
Input		040	060	080	100	040	060	080	100
No. of 90 ELL	1	73	58	42	42	121	121	114	114
	2	68	53	37	37	116	116	109	109
	3	63	48	32	32	111	111	104	104
	4	58	43	27	27	106	106	99	99
	5	53	38	22	22	101	101	94	94
	6	48	33	17	17	96	96	89	89
	7	43	28	12	12	91	91	84	84
	8	38	23	N/A	N/A	86	86	79	79
	9	33	18	N/A	N/A	81	81	74	74
	10	28	13	N/A	N/A	76	76	69	69

CONCENTRIC TERMINATION AT ELEVATION 4501 - 7500 FT.

Pipe Size		2 in.				3 in.			
Input		040	060	080	100	040	060	080	100
No. of 90 ELL	1	73	33	32	N/A	121	89	89	61
	2	68	28	27	N/A	116	84	84	56
	3	63	23	22	N/A	111	79	79	51
	4	58	18	17	N/A	106	74	74	46
	5	53	13	12	N/A	101	69	69	41
	6	48	N/A	N/A	N/A	96	64	64	36
	7	43	N/A	N/A	N/A	91	59	59	31
	8	38	N/A	N/A	N/A	86	54	54	26
	9	33	N/A	N/A	N/A	81	49	49	21
	10	28	N/A	N/A	N/A	76	44	44	16

VENT LENGTHS (EXHAUST) - VENTILATED ATTIC OR CRAWLSPACE INTAKE AIR - FEET

STANDARD TERMINATION AT ELEVATION 0 - 4500 FT.

Pipe Size		2 in.				3 in.			
	Input	040	060	080	100	040	060	080	100
No. of 90 ELL	1	71	56	34	14	118	117	98	98
	2	66	51	29	9	113	112	93	93
	3	61	46	24	4	108	107	88	88
	4	56	41	19	N/A	103	102	83	83
	5	51	36	14	N/A	98	97	78	78
	6	46	31	9	N/A	93	92	73	73
	7	41	26	4	N/A	88	87	68	68
	8	36	21	N/A	N/A	83	82	63	63
	9	31	16	N/A	N/A	78	77	58	58
	10	26	11	N/A	N/A	73	72	53	53

STANDARD TERMINATION AT ELEVATION 4501 - 7500 FT.

Pipe Size		2 in.				3 in.			
	Input	040	060	080	100	040	060	080	100
No. of 90 ELL	1	71	31	24	N/A	118	85	80	45
	2	66	26	19	N/A	113	80	75	40
	3	61	21	14	N/A	108	75	70	35
	4	56	16	9	N/A	103	70	65	30
	5	51	11	N/A	N/A	98	65	60	25
	6	46	N/A	N/A	N/A	93	60	55	20
	7	41	N/A	N/A	N/A	88	55	50	15
	8	36	N/A	N/A	N/A	83	50	45	10
	9	31	N/A	N/A	N/A	78	45	40	N/A
	10	26	N/A	N/A	N/A	73	40	35	N/A

INSTALLATION CLEARANCES

Sides	¹ 1 inches (25 mm)
Rear	1 inches (25 mm)
Top/Plenum	1 inch (25 mm)
Front	1 inches (25 mm)
Front (service/alcove)	24 inches (610 mm)
Floor	² Combustible

NOTE - Air for combustion must conform to the methods outlined in the National Fuel Gas Code (NFPA 54/ANSI-Z223.1) or the National Standard of Canada CAN/CSA-B149.1 Natural Gas and Propane Installation Code[®].

NOTE - In the U.S. flue sizing must conform to the methods outlined in the current National Fuel Gas Code (NFPA 54/ANSI-Z223.1) or applicable provisions of local building codes. In Canada flue sizing must conform to the methods outlined in National Standard of Canada CAN/CSA-B149.1.

¹ Allow proper clearances to accommodate condensate trap and vent pipe installation.

² Do not install the furnace directly on carpeting, tile, or other combustible materials other than wood flooring.

BLOWER DATA

EL195UH040NE36BK PERFORMANCE (Less Filter)

External Static Pressure in. w.g.	Air Volume / Watts at Various Blower Speeds									
	High (Black)		Medium-High (Brown)		Medium (Blue)		Medium-Low (Yellow)		Low (Red)	
	cfm	Watts	cfm	Watts	cfm	Watts	cfm	Watts	cfm	Watts
0.10	1413	358	1257	255	1155	202	914	114	871	97
0.20	1385	366	1231	267	1124	214	875	120	820	106
0.30	1354	383	1199	277	1091	223	832	130	776	114
0.40	1336	396	1171	289	1062	232	791	137	740	124
0.50	1280	392	1140	301	1019	244	751	148	684	131
0.60	1211	375	1111	307	985	254	702	158	642	140
0.70	1129	351	1071	323	959	263	658	163	589	147
0.80	1009	319	996	309	917	275	613	172	555	151
0.90	846	273	858	273	812	259	575	178	509	158
1.00	730	246	719	245	702	236	530	185	466	166

EL195UH060NE36BK PERFORMANCE (Less Filter)

External Static Pressure in. w.g.	Air Volume / Watts at Various Blower Speeds									
	High (Black)		Medium-High (Brown)		Medium (Blue)		Medium-Low (Yellow)		Low (Red)	
	cfm	Watts	cfm	Watts	cfm	Watts	cfm	Watts	cfm	Watts
0.10	1416	339	1253	249	1145	194	904	109	856	96
0.20	1395	351	1223	258	1118	205	865	118	812	103
0.30	1369	364	1198	270	1083	212	830	127	777	111
0.40	1342	377	1169	279	1055	222	793	134	744	117
0.50	1321	384	1141	289	1024	230	756	143	698	126
0.60	1292	396	1117	300	996	242	718	151	664	133
0.70	1246	395	1091	307	965	251	673	157	615	142
0.80	1179	376	1065	316	934	262	635	164	576	147
0.90	1082	349	1020	323	906	267	594	171	533	155
1.00	975	318	927	300	875	275	565	177	504	161

EL195UH080NE48CK PERFORMANCE (Less Filter)

External Static Pressure in. w.g.	Air Volume / Watts at Various Blower Speeds									
	High (Black)		Medium-High (Brown)		Medium (Blue)		Medium-Low (Yellow)		Low (Red)	
	cfm	Watts	cfm	Watts	cfm	Watts	cfm	Watts	cfm	Watts
0.10	1651	400	1441	286	1314	225	1236	189	1114	151
0.20	1622	414	1419	303	1286	241	1201	204	1077	160
0.30	1603	433	1386	316	1253	254	1163	217	1038	174
0.40	1581	452	1355	331	1222	265	1122	229	996	184
0.50	1548	467	1322	347	1182	278	1094	240	948	193
0.60	1522	479	1293	358	1157	290	1053	252	908	203
0.70	1441	465	1258	371	1104	304	1011	264	876	212
0.80	1341	435	1211	382	1083	312	984	271	827	222
0.90	1228	403	1159	372	1037	324	938	281	799	230
1.00	1132	377	1034	342	987	323	913	291	769	239

BLOWER DATA

EL195UH100NE60CK PERFORMANCE (Less Filter)

External Static Pressure in. w.g.	Air Volume / Watts at Different Blower Speeds																			
	Bottom Return Air, Side Return Air with Return Air from Both Sides or Return Air from Bottom and One Side.											Single Side Return Air – Air volumes in bold (over 1800 cfm) require Optional Return Air Base and field fabricated transition to accommodate 20 x 25 x 1 in. air filter in order to maintain proper air velocity.								
	High (Black)		Medium-High (Brown)		Medium (Blue)		Medium-Low (Yellow)		Low (Red)		High (Black)		Medium-High (Brown)		Medium (Blue)		Medium-Low (Yellow)		Low (Red)	
	cfm	Watts	cfm	Watts	cfm	Watts	cfm	Watts	cfm	Watts	cfm	Watts	cfm	Watts	cfm	Watts	cfm	Watts	cfm	Watts
0.10	2064	683	1822	466	1662	363	1559	306	1387	222	2045	678	1837	466	1648	366	1527	300	1358	218
0.20	2034	700	1793	480	1621	379	1520	318	1337	233	2009	698	1765	482	1611	377	1489	315	1313	228
0.30	1997	715	1750	497	1587	390	1479	330	1297	244	1981	713	1737	497	1574	391	1448	327	1270	240
0.40	1967	730	1719	513	1548	402	1447	341	1254	254	1954	729	1701	508	1535	402	1419	337	1224	251
0.50	1940	739	1682	525	1514	415	1400	354	1205	266	1915	740	1663	522	1501	414	1378	349	1186	261
0.60	1867	729	1649	537	1469	428	1362	364	1162	275	1859	731	1625	538	1457	428	1338	360	1139	273
0.70	1794	701	1615	552	1441	436	1326	375	1125	285	1787	706	1596	550	1418	438	1298	367	1090	284
0.80	1706	668	1581	567	1399	451	1280	387	1077	295	1697	674	1553	565	1383	452	1262	383	1065	288
0.90	1596	624	1532	574	1366	463	1249	397	1039	301	1604	635	1524	572	1344	463	1223	395	1017	302
1.00	1490	584	1455	554	1329	474	1210	407	993	312	1482	586	1444	552	1318	475	1183	406	973	310

DIMENSIONS

UNIT - UPFLOW POSITION

- ¹ NOTE - 60C size units that require air volumes over 1800 cfm must have one of the following:
1. Single side return air and Optional Return Air Base with transition that must accommodate required 20 x 25 x 1 inch (508 x 635 x 25 mm) air filter to maintain proper velocity.
 2. Bottom return air.
 3. Return air from both sides.
 4. Bottom and one side return air.
- See Blower Performance Tables for additional information.

² Optional Side Return Air Filter Kit is not for use with the Optional Return Air Base.

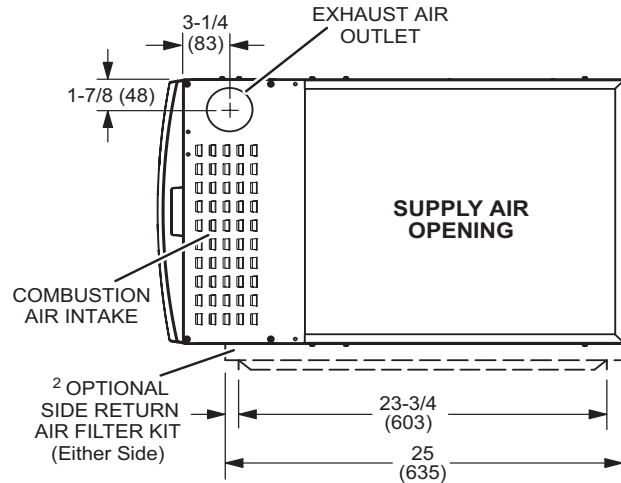

TOP VIEW

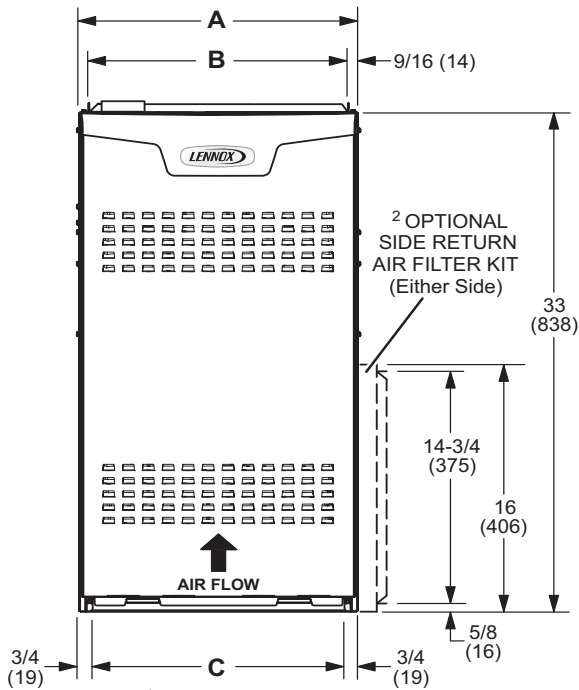

FRONT VIEW

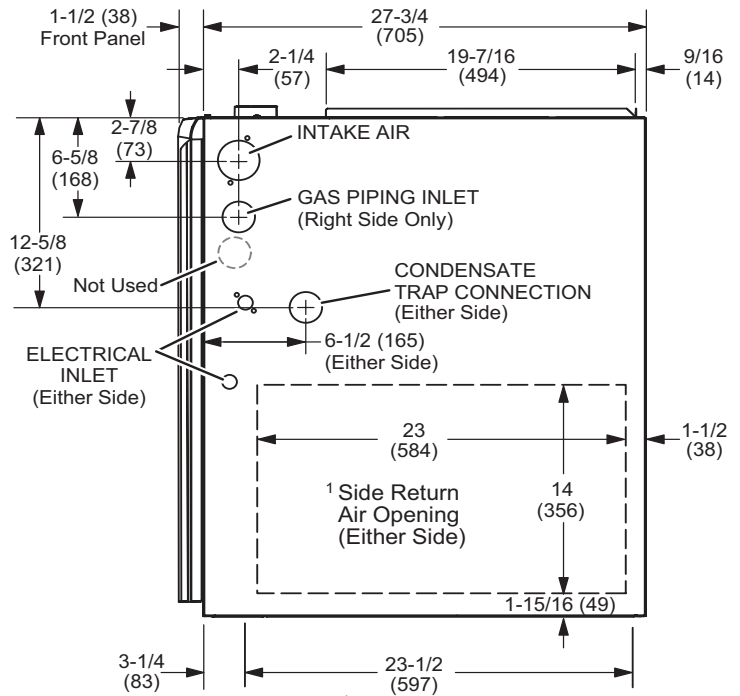

SIDE VIEW

Model No.	A		B		C	
	in.	mm	in.	mm	in.	mm
EL195UH040NE36BK EL195UH060NE36BK	17-1/2	445	16-3/8	416	16	406
EL195UH080NE48CK EL195UH100NE60CK	21	533	19-7/8	505	19-1/2	495

LEFT-HAND AIR DISCHARGE

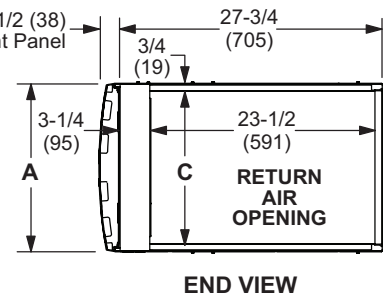
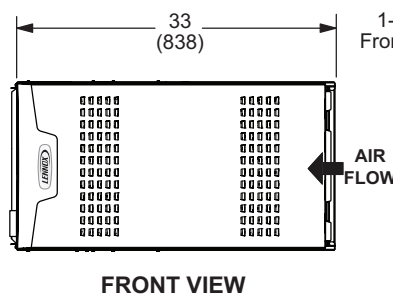
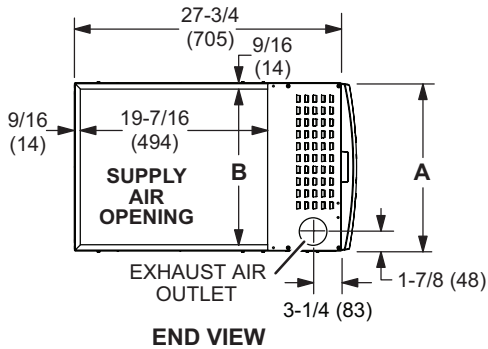
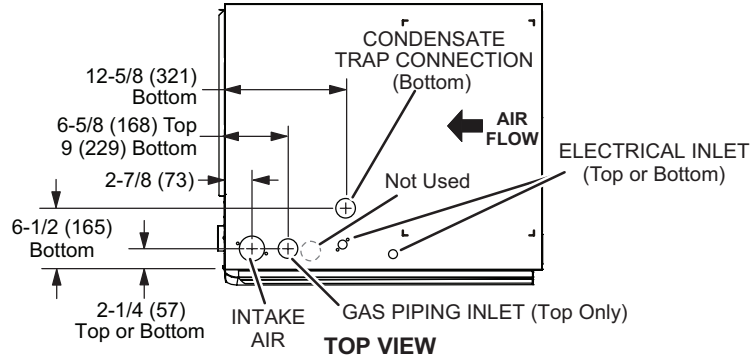

RIGHT-HAND AIR DISCHARGE

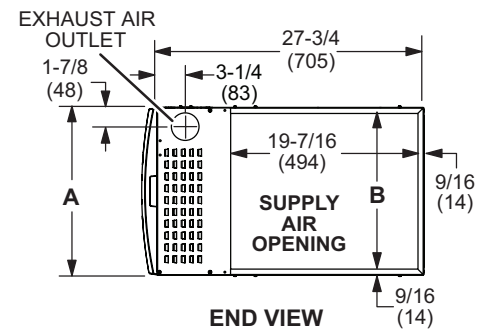
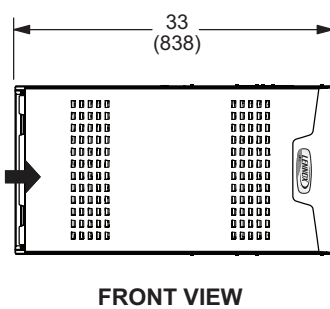
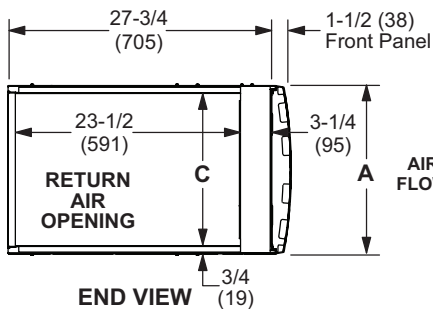
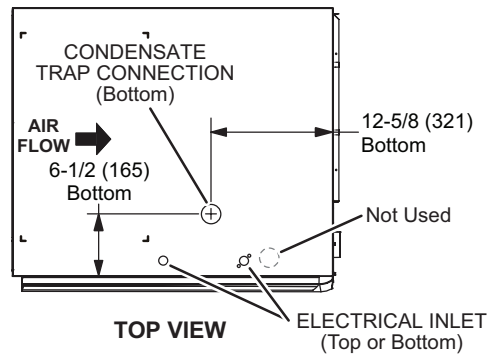

Model No.	A		B		C	
	in.	mm	in.	mm	in.	mm
EL195UH040NE36BK EL195UH060NE36BK	17-1/2	445	16-3/8	416	16	406
EL195UH080NE48CK EL195UH100NE60CK	21	533	19-7/8	505	19-1/2	495

HORIZONTAL (END) FILTER KIT

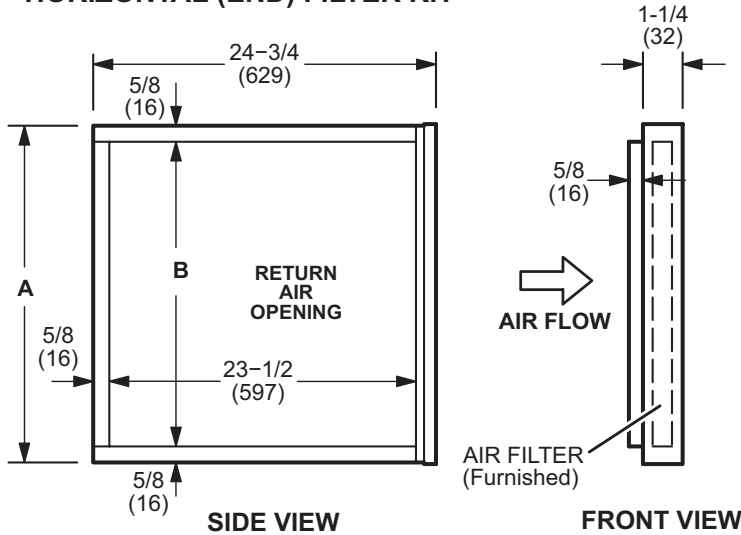

Furnace Cabinet Width	Catalog Number	A		B	
		in.	mm	in.	mm
B	87L96	18	457	16-3/4	425
C	87L97	21	533	18-3/4	476

**Optional Return Air Base
(Upflow Applications Only - For use with B and C cabinets)**

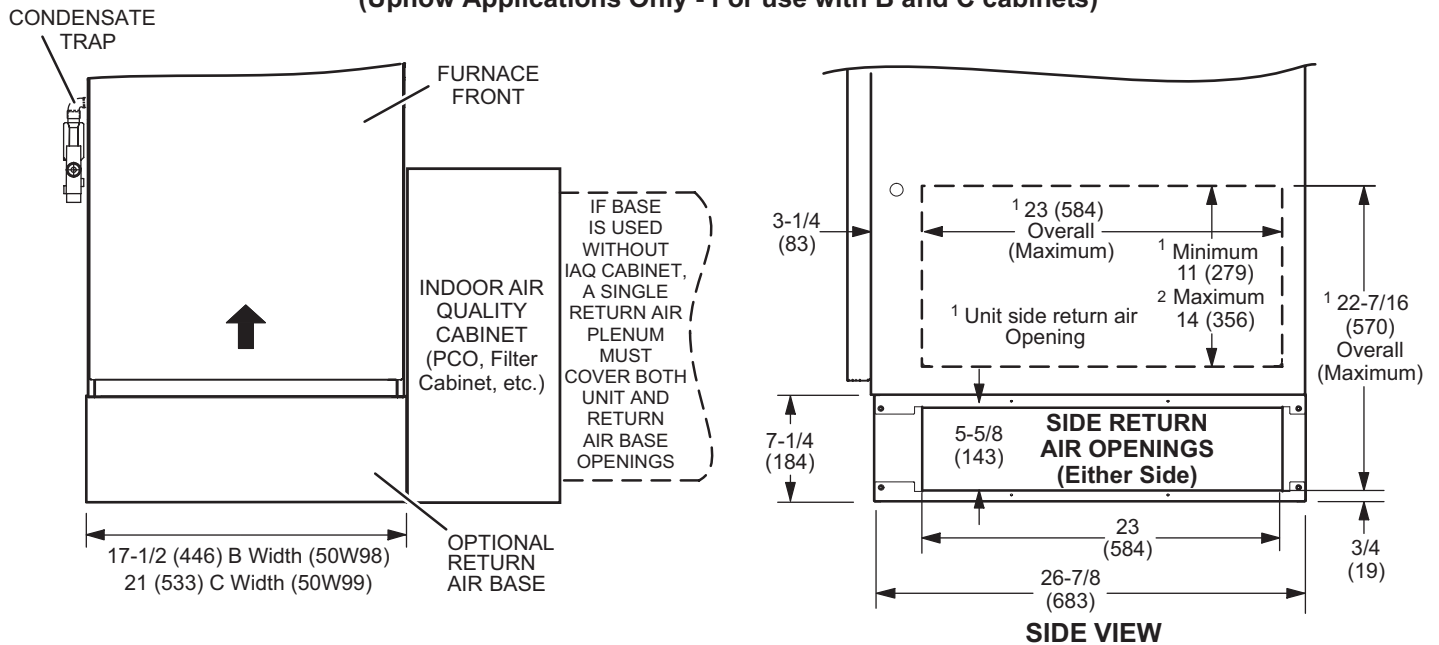

NOTE- Optional Side Return Air Filter Kits are not for use with Optional Return Air Base.

- ¹ Both the unit return air opening and the base return air opening must be covered by a single plenum or IAQ cabinet. Minimum unit side return air opening dimensions for units requiring 1800 cfm or more of air (W x H): 23 x 11 in. (584 x 279 mm). The opening can be cut as needed to accommodate plenum or IAQ cabinet while maintaining dimensions shown. Side return air openings must be cut in the field. There are cutting guides stenciled on the cabinet for the side return air opening. The size of the opening must not extend beyond the markings on the furnace cabinet.
- ² To minimize pressure drop, the largest opening height possible, up to 14 in. (356 mm), is preferred.

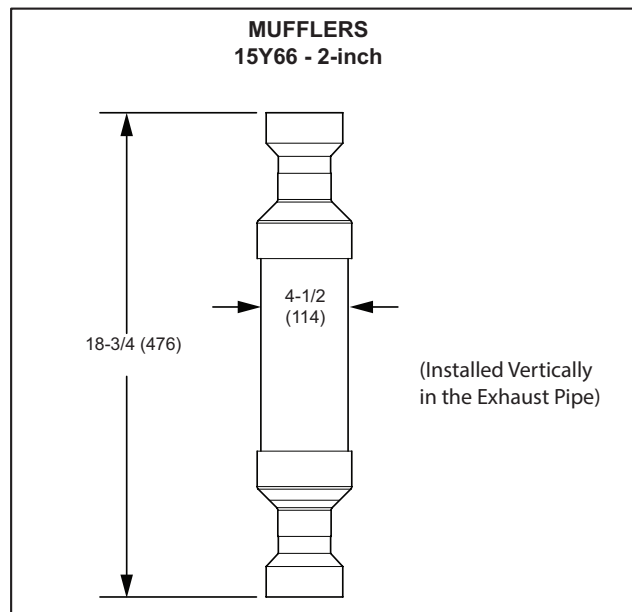
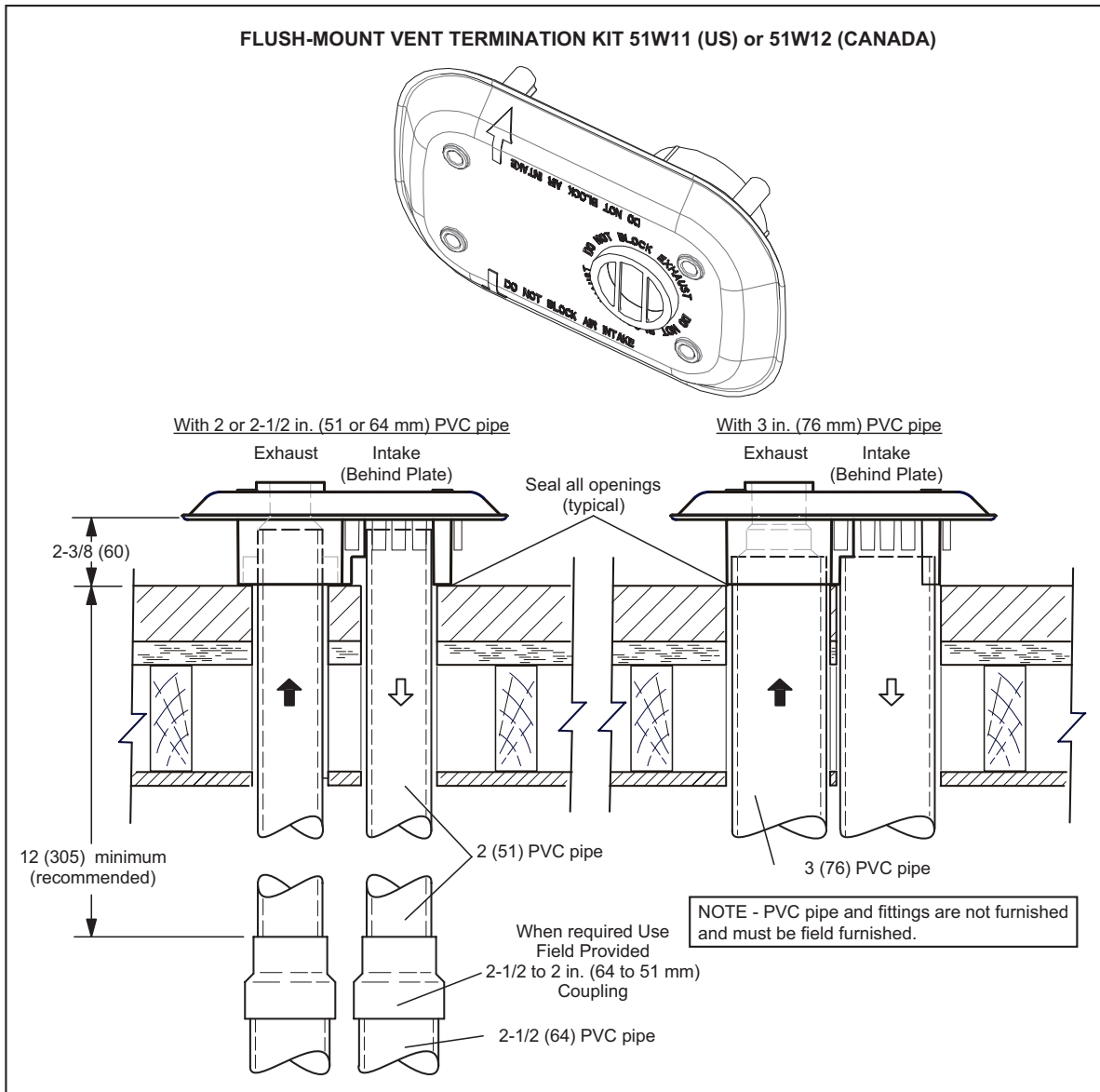

CONCENTRIC WALL TERMINATION APPLICATIONS

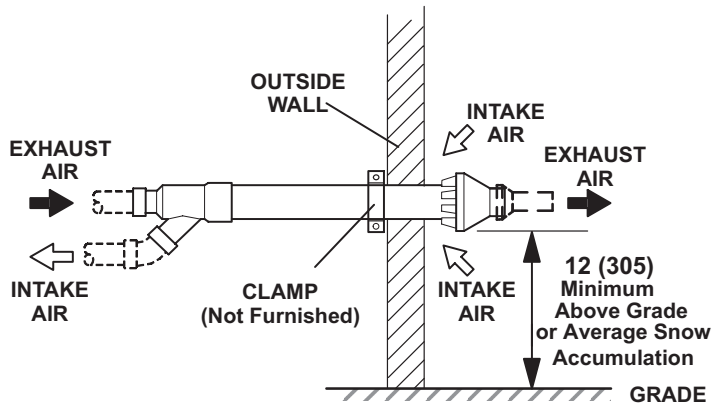

CONCENTRIC ROOF TERMINATION APPLICATIONS

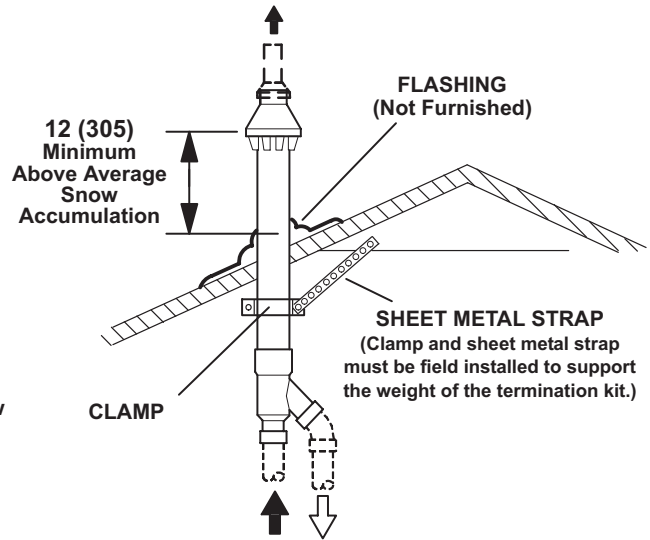

**71M80 / 69M29 / 44W92 – 2 inch kits
60L46 / 44W93 – 3 inch kits**
See Installation Instructions for additional information.

Note - Field provided reducer may be required to adapt different vent pipe sizes to termination.

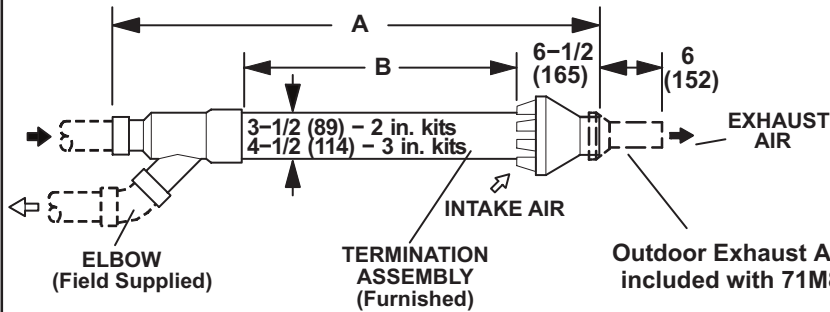

Cat. No.	A		B	
	in.	mm	in.	mm
71M80 69M29	33-3/8	848	16-3/4	425
44W92 (Canada)	29	737	15-1/2	394
60L46	38-7/8	987	21-3/16	538
44W93 (Canada)	36-1/8	918	19-1/2	495

NOTE – Typical illustration for dimensions only. Design may vary depending on kit ordered.

**WALL TERMINATION KITS (CLOSE-COUPLE)
EXTENDED VENT FOR GRADE CLEARANCE
2 inch (51 mm) 22G44 (US)
3 inch (76 mm) 44J40 (US)**

See Installation Instructions for additional information.

Note - Field provided reducer may be required to adapt different vent pipe sizes to termination.

If Intake and Exhaust Pipe is less than 12 in. (305 mm) above snow accumulation or other obstructions, field fabricated piping must be installed.

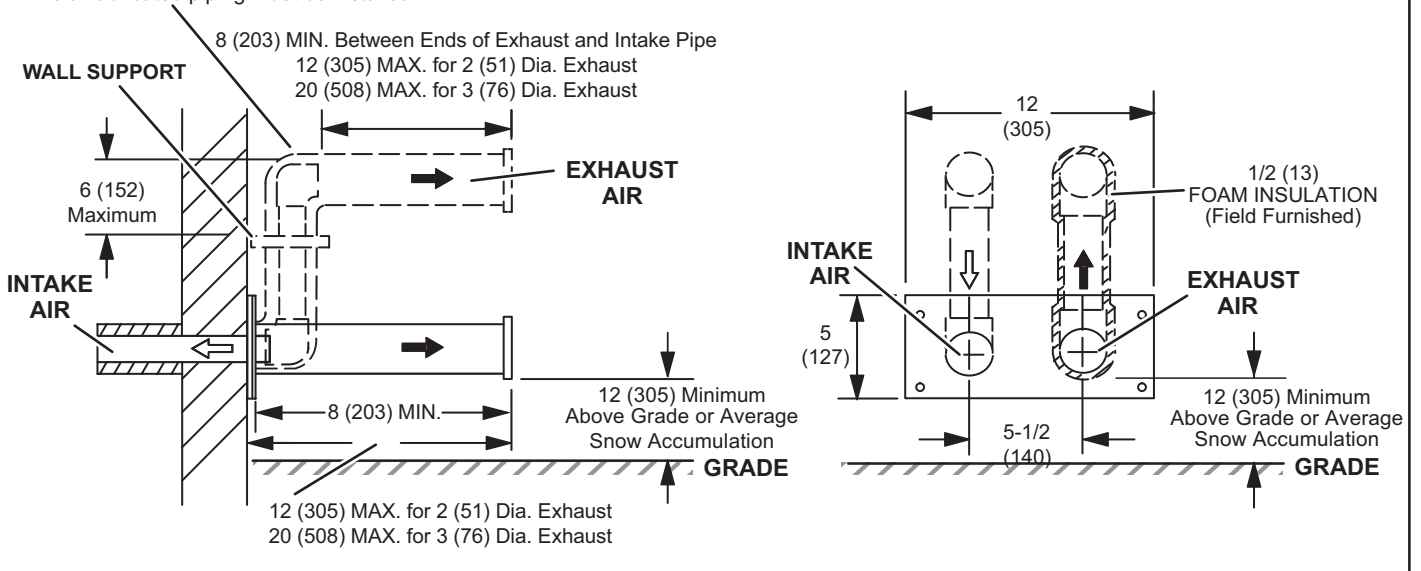

**WALL TERMINATION KITS (CLOSE-COUPLE)
EXTENDED VENT FOR GRADE CLEARANCE
2 inch (51 mm) 30G28 (WTK Canada)
3 inch (76 mm) 81J20 (WTK Canada)**

See Installation Instructions for additional information.

Note - Field provided reducer may be required to adapt different vent pipe sizes to termination.

If Intake and Exhaust Pipe is less than 12 in. (305 mm) above snow accumulation or other obstructions, field fabricated piping must be installed.

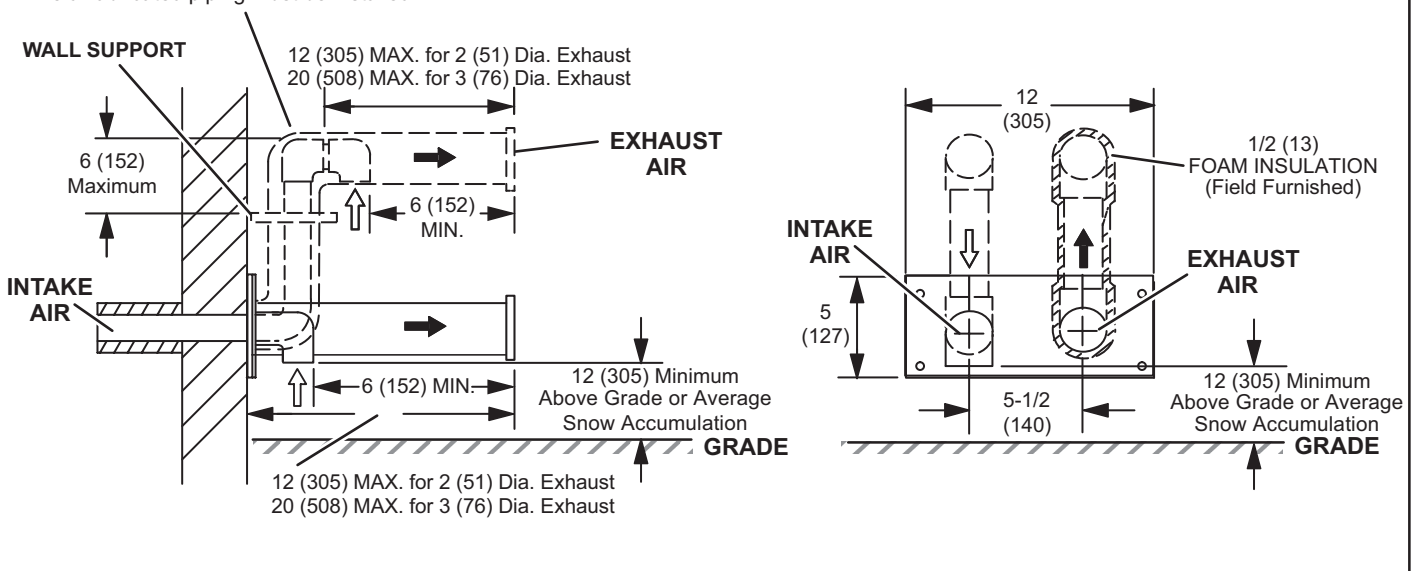

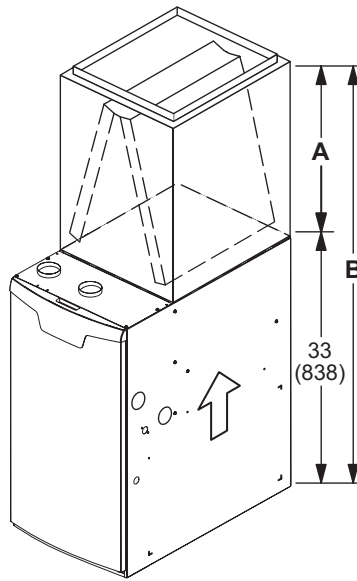

UPFLOW POSITION - CASED

Model	A		B	
	in.	mm	in.	mm
CK40CT				
CK40CT-18/24B	16-1/2	419	49-1/2	1257
CK40CT-24B	18-1/2	470	51-1/2	1308
CK40CT-30B	22-1/2	572	55-1/2	1410
CK40CT-30/36B CK40CT-30/36C	24-1/2	622	57-1/2	1461
CK40CT-36B CK40CT-36C	24-1/2	622	57-1/2	1461
CK40CT-48B CK40CT-48C	27-1/2	699	60-1/2	1537
CK40CT-49C	29-1/2	749	62-1/2	1588
CK40CT-50/60C	27-1/2	699	60-1/2	1537
CK40CT-60C	31-1/2	800	64-1/2	1638

UPFLOW POSITION - UNCASSED

Model	A		B	
	in.	mm	in.	mm
CK40UT				
CK40UT-18/24B	14-1/8	359	47-1/8	1197
CK40UT-24B	16-3/8	416	49-3/8	1254
CK40UT-30B	20-3/4	527	53-3/4	1365
CK40UT-30/36B CK40UT-30/36C CK40UT-36C	22-1/4	565	55-1/4	1403
CK40UT-36B	22-3/8	568	55-3/8	1407
CK40UT-48B CK40UT-48C	26-1/4	667	59-1/4	1505
CK40UT-49C	28-1/2	724	61-1/2	1562
CK40UT-50/60C	25-7/8	657	58-7/8	1495
CK40UT-60C	30-5/8	778	63-5/8	1616

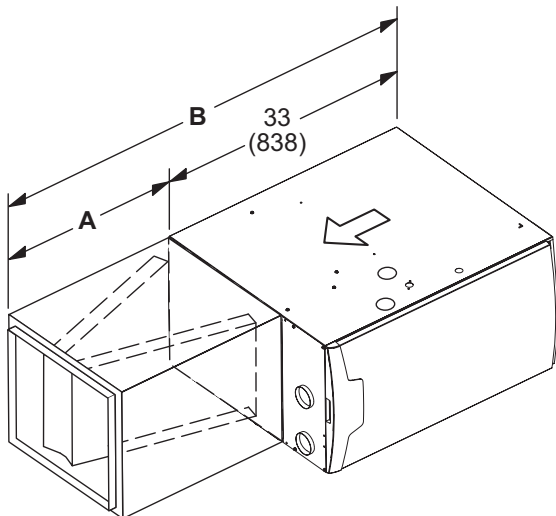

HORIZONTAL POSITION

Model	A		B	
	in.	mm	in.	mm
CK40HT				
CK40HT-24B CK40HT-30B CK40HT-36B CK40HT-36C CK40HT-42C CK40HT-48C	26-1/2	673	59-1/2	1511
CK40CT-42B CK40CT-48B CK40CT-51/61C	31-1/2	880	64-1/2	1638

REVISIONS

Sections	Description of Change
Approvals	Updated ENERGY STAR® usage.
Control Options	Updated to reflect latest product offering.
Dimensions	Updated Furnace/Coil Combined Dimensions to add latest product offering.



Visit us at www.Lennox.com

For the latest technical information, www.LennoxPros.com

Contact us at 1-800-9-LENNOX

NOTE - Due to Lennox' ongoing commitment to quality, Specifications, Ratings and Dimensions subject to change without notice and without incurring liability. Improper installation, adjustment, alteration, service or maintenance can cause property damage or personal injury. Installation and service must be performed by a qualified installer and servicing agency.

©2026 Lennox Industries, Inc.