



538167-02

01

02

03

04

05

06

07

08

09

10

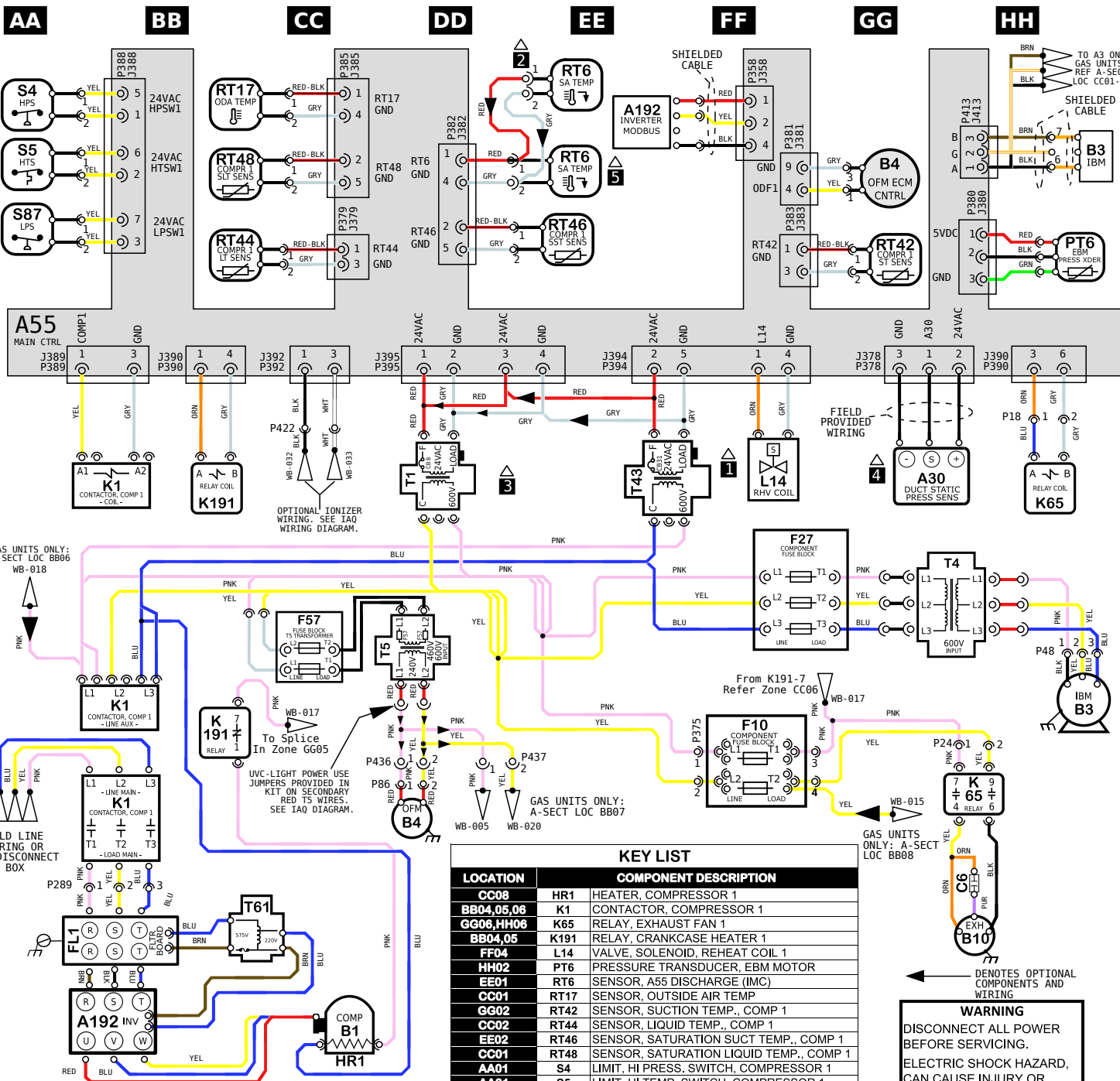

LOCATION	COMPONENT DESCRIPTION
AA02	A55 CONTROL BOARD, MAIN
GG04	A30 SENSOR, DUCT STATIC PRESS.
EE01, BB08	A192 INVERTER, COMPRESSOR 1
CC08	B1 COMPRESSOR 1
EE06	B3 MOTOR, BLOWER
DD05, GG01	B4 MOTOR, OUTDOOR FAN 1
HH06	B10 MOTOR, EXHAUST FAN 1
HH05	C6 CAPACITOR, EXHAUST FAN 1
FF06	F10 FUSE, SCCR RELAY
EE05	F27 FUSE, T4 TRANSFORMER PRIMARY
CC05	F57 FUSE, T5 TRANSFORMER PRIMARY
AA07	FL1 FILTER BOARD

LOCATION	COMPONENT DESCRIPTION
CC08	HR1 HEATER, COMPRESSOR 1
BB04,05,06	K1 CONTACTOR, COMPRESSOR 1
GG06,HH06	K65 RELAY, EXHAUST FAN 1
BB04,05	K191 RELAY, CRANKCASE HEATER 1
FF04	L14 VALVE, SOLENOID, REHEAT COIL 1
HH02	PT6 PRESSURE TRANSDUCER, EBM MOTOR
EE01	RT6 SENSOR, A55 DISCHARGE (IMC)
CC01	RT17 SENSOR, OUTSIDE AIR TEMP
GG02	RT42 SENSOR, SUCTION TEMP., COMP 1
CC02	RT44 SENSOR, LIQUID TEMP., COMP 1
EE02	RT46 SENSOR, SATURATION SUCT TEMP., COMP 1
CC01	RT48 SENSOR, SATURATION LIQUID TEMP., COMP 1
AA01	S4 LIMIT, HI PRESS. SWITCH, COMPRESSOR 1
AA01	S5 LIMIT, HI TEMP. SWITCH, COMPRESSOR 1
AA02	S87 SWITCH, LOW PRESS., COMP. 1
DD04	T1 TRANSFORMER, CONTROL
GG05	T4 TRANSFORMER, BLOWER MOTOR
DD05	T5 TRANSFORMER, OUTDOOR FAN MOTOR
EE04	T43 TRANSFORMER, REHEAT
CC07	T61 TRANSFORMER, INV INTERNAL POWER

NOTES	
1	ONLY ON UNITS WITH HUMIDITROL OPTION
2	RT6 REMOTE MOUNT WIRING
3	T1 CONNECTED TO J/P395-1,2 ONLY WITH HUMIDITROL
4	USED ON VAV UNITS ONLY
5	FOR MODULATING GAS HEAT UNIT ONLY, REFER TO RT6 AS SHOWN IN THE HEATING WIRING DIAGRAM (A-SECTION)

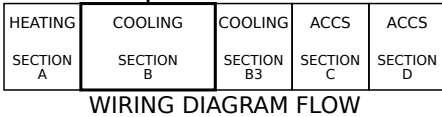

WARNING
DISCONNECT ALL POWER BEFORE SERVICING.
ELECTRIC SHOCK HAZARD, CAN CAUSE INJURY OR DEATH. UNIT MUST BE GROUNDED IN ACCORDANCE WITH NATIONAL AND LOCAL CODES.
FOR USE WITH COPPER CONDUCTORS ONLY. REFER TO UNIT RATING PLATE FOR MINIMUM CIRCUIT AMPACITY AND MAXIMUM OVERCURRENT PROTECTION SIZE.
IF ANY WIRE IN THIS APPLIANCE IS REPLACED, IT MUST BE REPLACED WITH WIRE OF LIKE SIZE, RATING AND INSULATION THICKNESS.

Model: LCM, LGM 036U - 074U J VOLT Cooling Diagram with Higher SCCR
Voltage: 600/3/60 (J)
Supersedes: N/A Form No: 538167-02 Rev: 3

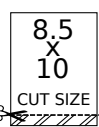

REV	EC NO.	DATE	BY	APVD	REVISION NOTE
--	CN-008852AS	01/10/2023	AXL	AAH	ORIGINATED AT PD&R CARROLLTON, TX
2	CN-014014F	1/6/2026	ZN	AWH	A) CLEANED UP WIRES TO GAS SECTION (A-SECT)
3	CN-013731A	3/3/2026	ZN	HMT	A) ADDED NOTE 5 FOR MODULATING GAS HEAT



538167-02

01

02

03

04

05

06

07

08

09

10

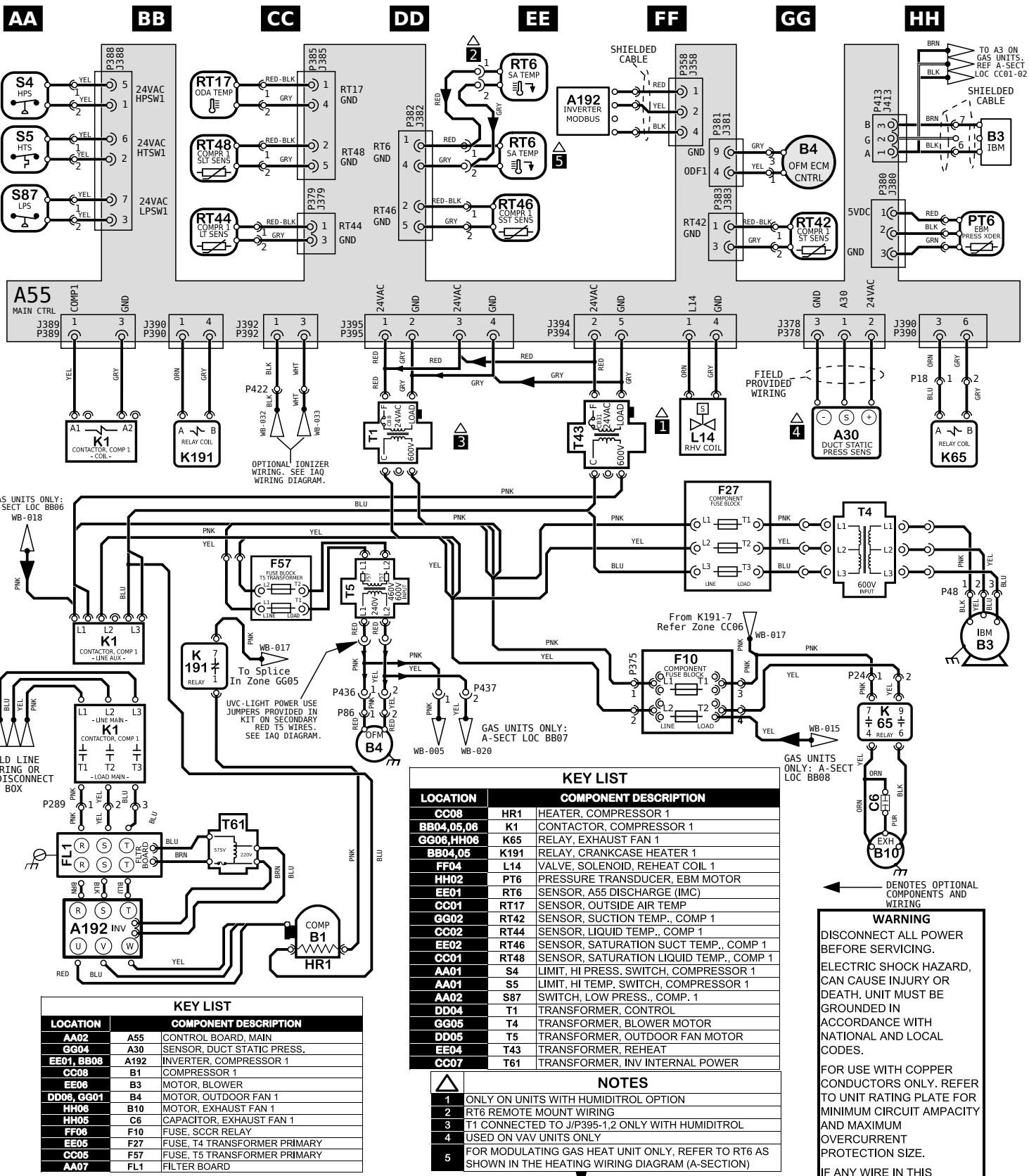

KEY LIST	
LOCATION	COMPONENT DESCRIPTION
CC08	HR1 HEATER, COMPRESSOR 1
BB04,05,06	K1 CONTACTOR, COMPRESSOR 1
GG06,HH06	K65 RELAY, EXHAUST FAN 1
BB04,05	K191 RELAY, CRANKCASE HEATER 1
FF04	L14 VALVE, SOLENOID, REHEAT COIL 1
HH02	PT6 PRESSURE TRANSDUCER, EBM MOTOR
EE01	RT6 SENSOR, A55 DISCHARGE (IMC)
CC01	RT17 SENSOR, OUTSIDE AIR TEMP
GG02	RT42 SENSOR, SUCTION TEMP., COMP 1
CC02	RT44 SENSOR, LIQUID TEMP., COMP 1
EE02	RT46 SENSOR, SATURATION SUCT TEMP., COMP 1
CC01	RT48 SENSOR, SATURATION LIQUID TEMP., COMP 1
AA01	S4 LIMIT, HI PRESS. SWITCH, COMPRESSOR 1
AA01	S5 LIMIT, HI TEMP. SWITCH, COMPRESSOR 1
AA02	S87 SWITCH, LOW PRESS., COMP. 1
DD04	T1 TRANSFORMER, CONTROL
GG05	T4 TRANSFORMER, BLOWER MOTOR
DD05	T5 TRANSFORMER, OUTDOOR FAN MOTOR
EE04	T43 TRANSFORMER, REHEAT
CC07	T61 TRANSFORMER, INV INTERNAL POWER

NOTES	
1	ONLY ON UNITS WITH HUMIDITROL OPTION
2	RT6 REMOTE MOUNT WIRING
3	T1 CONNECTED TO J/P395-1,2 ONLY WITH HUMIDITROL
4	USED ON VAV UNITS ONLY
5	FOR MODULATING GAS HEAT UNIT ONLY, REFER TO RT6 AS SHOWN IN THE HEATING WIRING DIAGRAM (A-SECTION)

KEY LIST	
LOCATION	COMPONENT DESCRIPTION
AA02	A55 CONTROL BOARD, MAIN
GG04	A30 SENSOR, DUCT STATIC PRESS.
EE01, BB08	A192 INVERTER, COMPRESSOR 1
CC08	B1 COMPRESSOR 1
EE06	B3 MOTOR, BLOWER
DD06, GG01	B4 MOTOR, OUTDOOR FAN 1
HH06	B10 MOTOR, EXHAUST FAN 1
HH05	C6 CAPACITOR, EXHAUST FAN 1
FF06	F10 FUSE, SCCR RELAY
EE05	F27 FUSE, T4 TRANSFORMER PRIMARY
CC05	F57 FUSE, T5 TRANSFORMER PRIMARY
AA07	FL1 FILTER BOARD

HEATING	COOLING	COOLING	ACCS	ACCS
SECTION A	SECTION B	SECTION B3	SECTION C	SECTION D

WARNING
DISCONNECT ALL POWER BEFORE SERVICING.
ELECTRIC SHOCK HAZARD, CAN CAUSE INJURY OR DEATH. UNIT MUST BE GROUNDED IN ACCORDANCE WITH NATIONAL AND LOCAL CODES.
FOR USE WITH COPPER CONDUCTORS ONLY. REFER TO UNIT RATING PLATE FOR MINIMUM CIRCUIT AMPACITY AND MAXIMUM OVERCURRENT PROTECTION SIZE.
IF ANY WIRE IN THIS APPLIANCE IS REPLACED, IT MUST BE REPLACED WITH WIRE OF LIKE SIZE, RATING AND INSULATION THICKNESS.

Model: LCM, LGM 036U - 074U J VOLT
Cooling Diagram with Higher SCCR
Voltage: 600/3/60 (J)
Supersedes: N/A Form No: 538167-02 Rev: 3

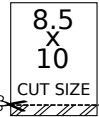

REV	EC NO.	DATE	BY	APVD	REVISION NOTE
--	CN-008852AS	01/10/2023	AXL	AAH	ORIGINATED AT PD&R CARROLLTON, TX
2	CN-014014F	1/6/2026	ZN	AWH	A) CLEANED UP WIRES TO GAS SECTION (A-SECT)
3	CN-013731A	3/3/2026	ZN	HMT	A) ADDED NOTE 5 FOR MODULATING GAS HEAT