

**LENNOX®**

PRODUCT LITERATURE

503,718M  
6/98  
Supersedes 8/97

**USER'S INFORMATION  
MANUAL**

**CompleteHeat™**

**COMBINATION  
HEATING  
SYSTEM**

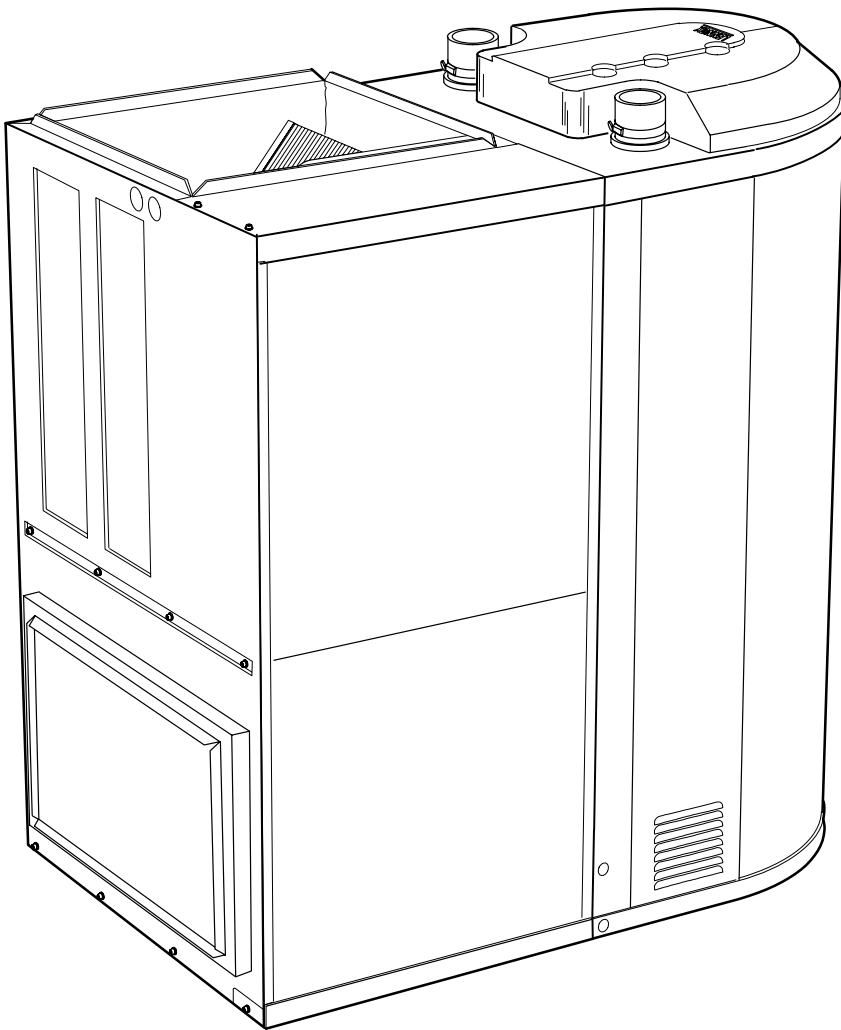

- SYSTEM OPERATION
- MAINTENANCE
- SAFETY CONSIDERATIONS

**TP** Technical  
Publications  
Litho U.S.A.

©1997 Lennox Industries Inc.

# **The CompleteHeat™ Combination Heating System**

Congratulations on the purchase of your Lennox CompleteHeat system. Lennox takes pride in manufacturing high quality products that keep you comfortable while saving you energy and money.

The CompleteHeat system is a high-efficiency combination water- and space-heating system. The system consists of an air module (AM30) and a heating module (HM30). The two units work together to provide warm air like a furnace and hot potable water like a hot water heater. The CompleteHeat system takes care of these needs while being up to 40% more efficient than standard furnaces and water heaters.

This booklet explains how the CompleteHeat system operates, how to identify the unit model number, how to operate a typical thermostat and how to maintain the system for optimum performance. Keep this booklet and the warranty shipped with the CompleteHeat system for future reference.

Thank you again for choosing Lennox.

# HOW THE CompleteHeat™ SYSTEM WORKS

The CompleteHeat system consists of a heating module (HM30) that produces hot water and an air handling module (AM30) that sends warmed air through the home's duct system. The two modules may be installed together (close-coupled) or apart (remote).

The system's operation begins when cold potable water fills the water storage tank through the pipe at the top of the HM30 unit. When heat is needed to produce warm water or air, the HM30 control tells the combustion air blower to draw in outside air for use in combustion. After a short safety delay, a fuel mixture is sent into the burner where it is ignited by an electronic spark. Burning fuel moves through the stainless steel heat exchanger inside the water storage tank. The water surrounding the heat exchanger is heated until the water temperature reaches the desired setpoint on the water thermostat dial.

Combustion products travel out of the heat exchanger, condensate water is drained, and exhaust gases are vented safely to the outdoors. Hot water is directed from the HM30 to faucets, shower heads, and appliances (such as the dishwasher and washing machine) through the plumbing located on top of the HM30 unit.

When the room thermostat senses a need for heat, the AM30 water circulating pump draws hot water from the HM30 heating module and routes it through the AM30 space heating coil. The aluminium and copper coil absorbs heat from the water. The blower turns on, blowing air across the heated coil. Warmed air is sent through the air duct system into the home. Water circulates back to the HM30 unit to be reheated until the room temperature reaches the thermostat setting.

## CompleteHeat Typical Applications

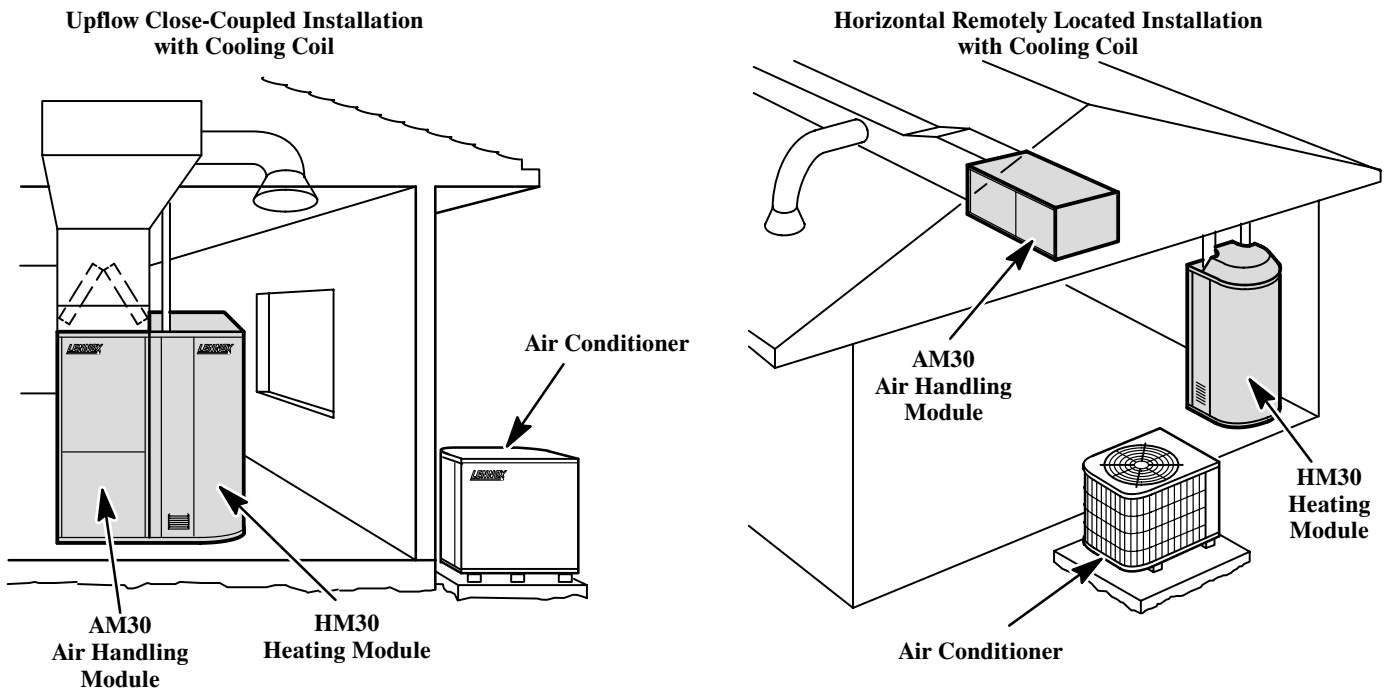

## SAFETY CONSIDERATIONS

Consider the materials stored near to the CompleteHeat system. Make sure the area around both AM30 and HM30 units has adequate space according to the prescribed clearances. **DO NOT** store combustible materials such as newspapers, rags, mops, or flammable liquids such as gasoline, kerosene, paint thinner near this or any other heating appliance.

### ⚠ DANGER



Vapors from flammable liquids will explode and catch fire causing death or severe burns.

**FOR YOUR SAFETY** - Do not store or use gasoline or other flammable, combustible, or corrosive vapors and liquids in the vicinity of this appliance.

Keep flammable products:

1. far away from heater,
2. in approved containers,
3. tightly closed, and
4. out of childrens reach.

Vapors:

1. cannot be seen,
2. are heavier than air,
3. go a long way on the floor and
4. can be carried from other rooms to the heater by air currents.

### ⚠ DANGER

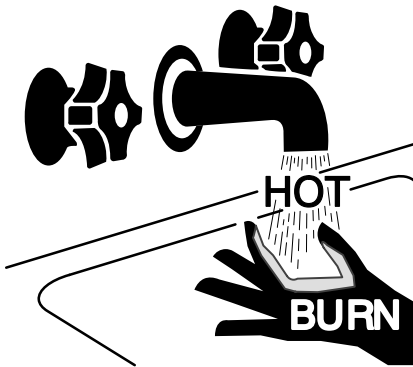

Water temperature over 125°F can cause severe burns instantly or death from scalds.

Children, disabled and elderly are at high risk of being scalded.

See the Adjusting Water Temperature section in this manual before setting temperature at heat module (HM30 unit). Feel water before bathing or showering. Temperature limiting valves are available and are recommended for all applications.

## TO START THE CompleteHeat SYSTEM

### **⚠ WARNING**

If you do not follow these instructions exactly, a fire or explosion may result causing property damage, personal injury or loss of life.

- 1– **STOP!** Read the safety information at the beginning of this section.
- 2– Set both room thermostat and water temperature dial to lowest settings.
- 3– Turn off all electrical power to the CompleteHeat system (AM30 & HM30 unit). Ask your dealer to identify the disconnect switch or circuit breaker.
- 4– The HM30 unit is equipped with an ignition device which automatically lights the burner. Do **not** try to light the burner by hand.
- 5– Turn knob on main manual shut-off valve 90° counterclockwise to **ON**. Do not force.
- 6– Turn on all electrical power to system.
- 7– Set room thermostat and water temperature dial to desired settings.

*NOTE – When unit is initially started, steps 1 through 7 may need to be repeated to purge air from gas line. The AM30 will not supply warm air until the water temperature in the HM30 tank is within 15° F (8.33° C) of the desired water thermostat setpoint.*

- 8– If the HM30 module will not operate, follow the instructions “To Turn Off Gas To Unit” and call your service technician or gas supplier.

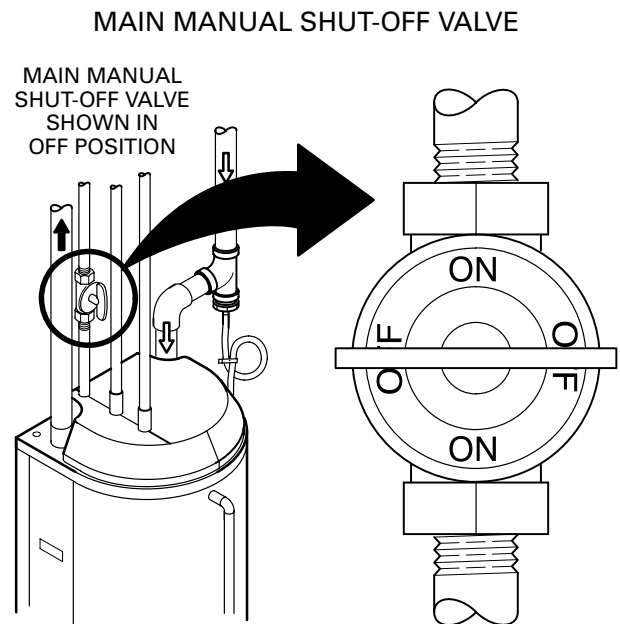

## TO SHUT OFF THE CompleteHeat SYSTEM

- 1– Set room thermostat and water temperature dial to lowest settings.
- 2– Turn off all electrical power to CompleteHeat system (AM30 and HM30).
- 3– Turn knob on main manual shut-off valve 90° clockwise to **OFF**. Do not force.

# HOW TO SET THE ROOM THERMOSTAT

Your thermostat may vary from this example; however, the operation is similar.

## TEMPERATURE SETTING LEVERS

Simply set the indicator lever or dial on the thermostat to the desired temperature for heating and cooling modes.

## FAN SWITCH

In **AUTO** or **INT** setting, the blower runs only when the thermostat calls for either heating or cooling. The **ON** or **CONT** setting runs the blower for constant air circulation and filtering, regardless of whether the equipment is heating or cooling. If your thermostat does not have **ON** or **CONT** settings and the continuous fan option is desired, ask your dealer about an optional continuous fan switch. In high humidity areas, the continuous fan operation tends to increase indoor humidity levels, ask your dealer which setting is best for your area.

## SYSTEM SWITCH

Set the system switch for either heating, cooling or auto (if available). Auto-changeover is a setting that allows the system to heat or cool, depending on the need, without manually switching from one to another. This setting is useful during seasonal changes when heating may be needed in the morning and cooling in the afternoon.

## TEMPERATURE INDICATOR

The temperature indicator needle shows the actual room temperature.

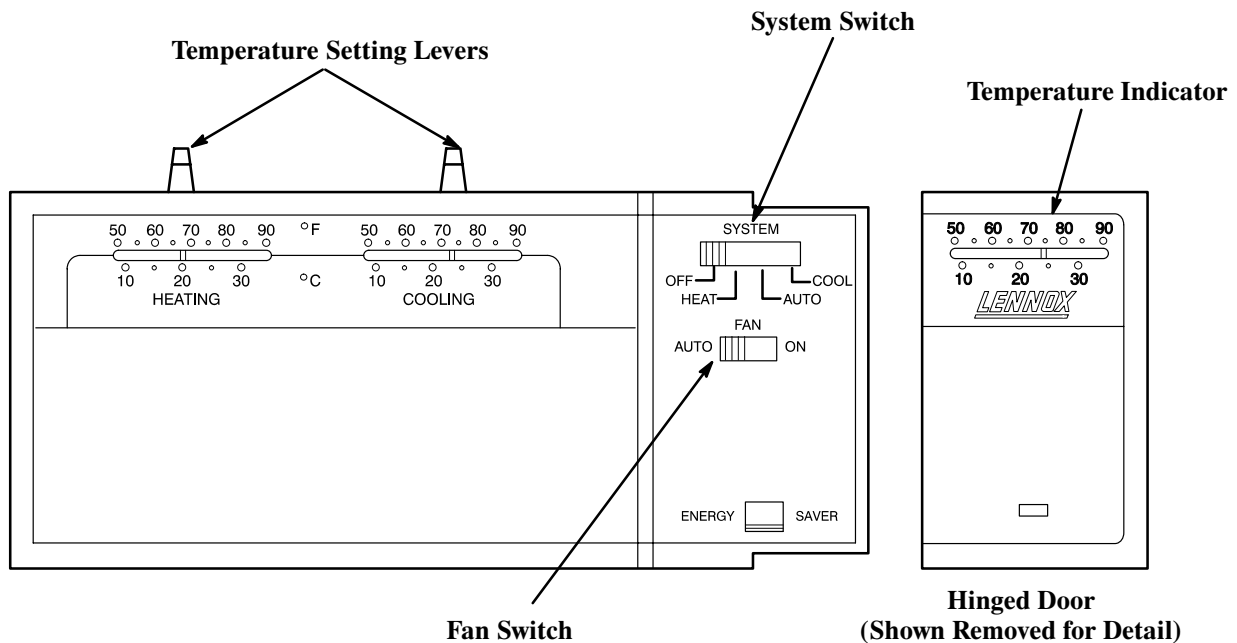

## PROGRAMMABLE THERMOSTATS

Many systems are installed with a programmable thermostat. These thermostats provide the same **SYSTEM** and **FAN** control as standard thermostats, but also provide the feature of setting certain temperatures for different times of the day or days of the week. Most provide for the selection of both heating and cooling set points (the temperature at which you want that mode to come on). Refer to the separate instructions provided with your programmable thermostat for operation and adjustments.

## ADJUSTING WATER TEMPERATURE

Remove the HM30 access panel. The water temperature dial is located at the lower left hand side of the HM30 control box. It is factory set at 120°F (49°C). Water temperature setting may be raised by turning dial clockwise to the desired setting. Temperature settings are marked from 110°F (43°C) to 140°F (60°C). Each dash mark represents an increase of 10°F (5.6°C). Some local building codes limit the temperature of potable water to 120°F (49°C). Ask your Lennox dealer for information on highest allowable water temperatures and the use of anti-scald and point-of-use water mixing valves. These valves help reduce the risk of scalding.

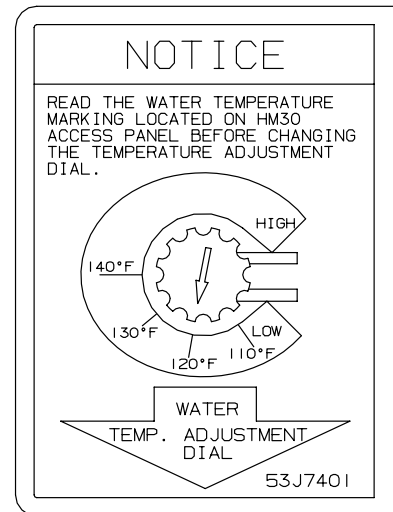

## KEEPING YOUR SYSTEM IN TOP FORM

### HM30 Tank Draining Procedure

It is recommended that 5 to 10 gallons of water from the HM30 tank be drained every six months to remove any sediment. This may need to be done more often in areas of poor water condition.

- 1– Turn off power to unit and allow water temperature in HM30 tank to cool.
- 2– Remove HM30 access panel.
- 3– Connect hose to drain valve and route to open drain.
- 4– Open drain valve to allow water to flow.
- 5– After draining, close drain valve and disconnect hose. Replace access panel.
- 6– Fill tank with water and re-apply power to the unit.

*DO NOT re-apply power to a dry tank. The burner should never operate with an empty water tank. Irreparable damage to the HM30 unit may occur.*

## KEEPING YOUR SYSTEM IN TOP FORM—CONT.

### **⚠ WARNING**



**Electric shock hazard. Can cause injury or death. Before attempting to perform any maintenance, turn the electrical power to unit OFF at disconnect switch(es). Unit may have multiple power supplies.**

### **AM30 Air Module and Filters**

Having a clean filter is the most important step in keeping your new heating and air conditioning system working to its full potential. Dirt, dust and pet hair clog the filter as air cycles through the system. Dirty filters make the equipment work harder which causes the unit to use more energy than normal. A system with dirty filters will not provide you with the comfort you expect. Cleaning or replacing the filter is much less expensive than higher energy bills or damaged equipment.

Make sure that all the power is **OFF** to the unit before attempting to change filter. Have the dealer show you where your unit's filter is located. The filter may be found either inside or outside the AM30 air module or in the wall at the return air grille. If the filter is in the air module, it may be inside the unit behind an access panel or located on the side of the unit in an external filter rack. If replacement is necessary, always replace it with the same type of filter. If you don't know what filter you need, call your Lennox dealer with the model number of the unit. The dealer will be able to tell you what type and size filter you need.

The filter shipped with the AM30 unit is reusable and can be cleaned with a mild soap and water. The filter should be completely dried before being returned to the unit. When replacing, look for the airflow direction arrow marked on the filter. Disposable filters (used at the return air grille) cannot be cleaned but should be replaced every month. During times of heavy usage, it is beneficial to vacuum the filter in between changes or cleanings.

Your system may include an electronic air cleaner which rids your home of even the smallest particles of dirt, dust and pollen. Ask your Lennox dealer to instruct you on its maintenance.

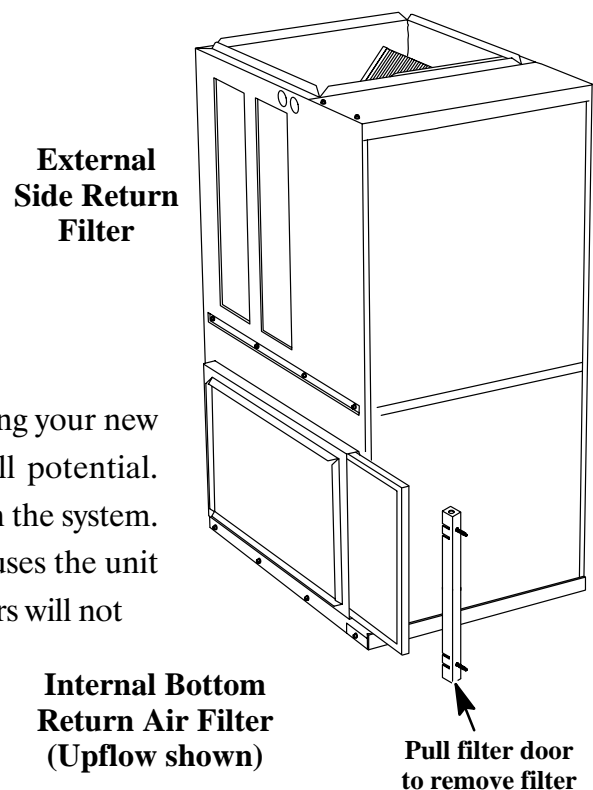

**External  
Side Return  
Filter**

**Internal Bottom  
Return Air Filter  
(Upflow shown)**

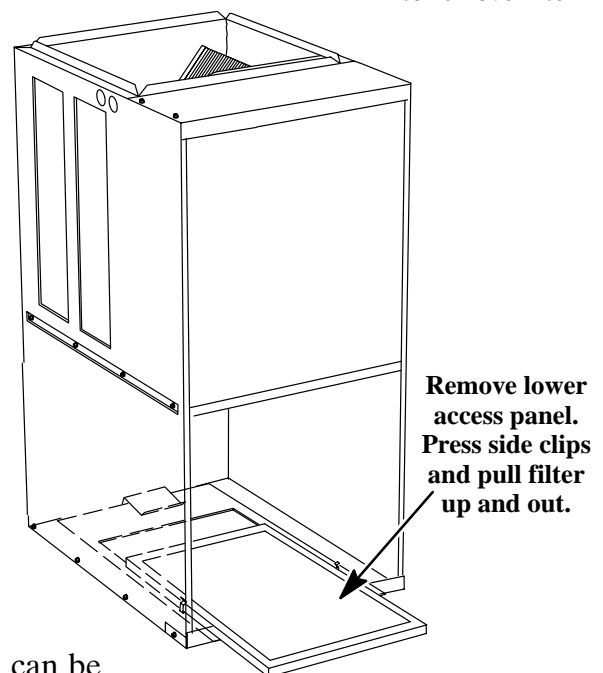

**Remove lower  
access panel.  
Press side clips  
and pull filter  
up and out.**

# KEEPING YOUR SYSTEM IN TOP FORM—CONT.

## HM30 Temperature / Pressure Relief Valve Testing

### TEMPERATURE / PRESSURE (T&P) RELIEF VALVE TESTING PROCEDURE

This valve is a safety device to protect against abnormally high temperature and pressures. Periodic discharge of the relief valve may indicate thermal expansion within a closed system.

A thermal expansion tank will be needed to allow water to expand.

If the valve discharges, it is doing so because there is a problem. Call your Lennox dealer or qualified technician to inspect the unit for proper operation. Do not ignore the water discharge. **Never plug the T&P relief valve.**

### **⚠ WARNING**

**Danger of Personal Injury from Scalding.** Water from T&P relief valve may be extremely hot and is not tempered. Use extreme caution when discharging valve. Replacement of T&P valve should be done by a trained professional or a licensed plumbing contractor.

T&P valve testing should be done annually. Remove HM30 top access panel. Locate the temperature and pressure relief valve.

Test the T&P valve by lifting the lever up until the valve unseats. This allows

the water to discharge. Never open the T&P valve unless it is connected to a discharge line.

If water does not flow, valve may be obstructed or corroded. Call your Lennox dealer or qualified technician to inspect the valve.

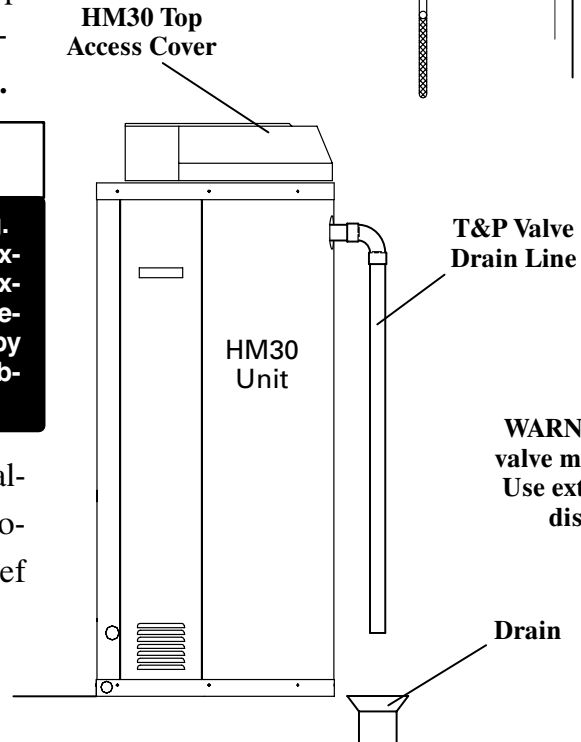
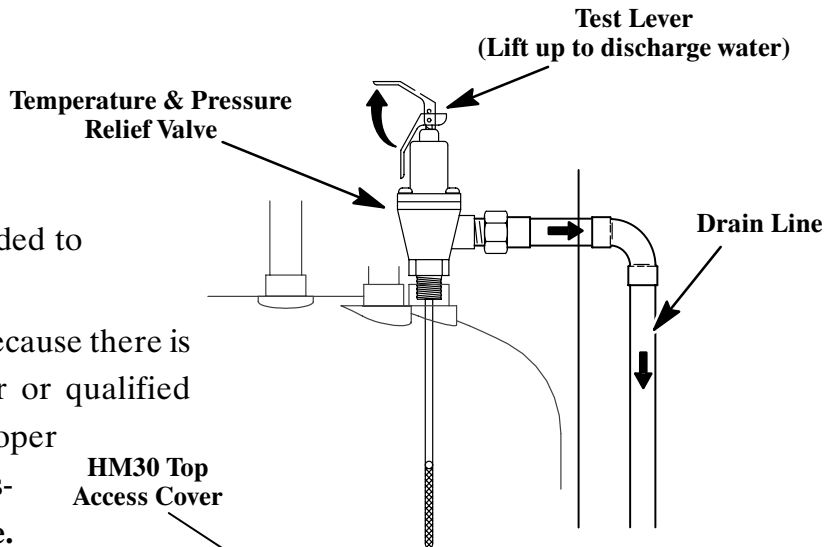

**WARNING – Water from valve may be extremely hot. Use extreme caution when discharging valve.**

## BEFORE CALLING FOR SERVICE...

- 1 Check to see that electrical disconnect switches are ON.
- 2 Make sure the room thermostat temperature selector and water temperature dial are properly set.
- 3 The room thermostat system switch should be in the ON position.
- 4 Replace any blown fuses, or reset circuit breakers.
- 5 Air filter should be clean.
- 6 Write down the unit model number before calling.

To keep your heating and cooling system running in peak operating condition year after year, contact your independent Lennox dealer about a service and maintenance program.

Have the Lennox dealer fill out this information for future reference.

AM30 Model # \_\_\_\_\_ Serial # \_\_\_\_\_

HM30 Model # \_\_\_\_\_ Serial # \_\_\_\_\_

Installer \_\_\_\_\_ Phone # \_\_\_\_\_

Date Installed \_\_\_\_\_ Filter Size and Type \_\_\_\_\_