

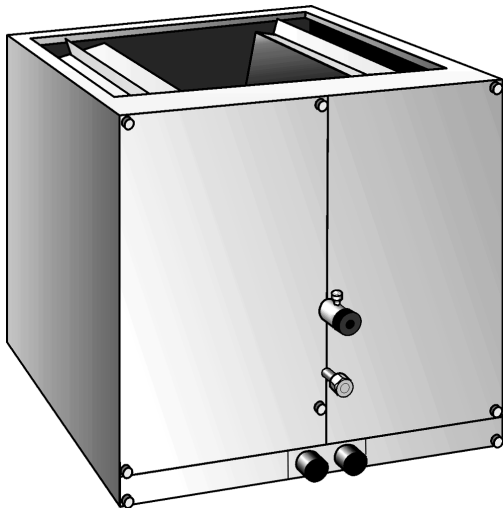

©2010 Lennox Industries Inc.  
Dallas, Texas, USA

# INSTALLATION INSTRUCTIONS

## CR33 Series Downflow Coils



EVAPORATOR COILS  
506563-01  
05/10  
Supersedes 505,056M

**TP** Technical  
Publications  
Litho U.S.A.

**RETAIN THESE INSTRUCTIONS FOR FUTURE  
REFERENCE**

### **⚠ WARNING**

Improper installation, adjustment, alteration, service or maintenance can cause personal injury, loss of life, or damage to property.

Installation and service must be performed by a licensed professional installer (or equivalent) or a service agency.

### **⚠ CAUTION**

Physical contact with metal edges and corners while applying excessive force or rapid motion can result in personal injury. Be aware of, and use caution when working near these areas during installation or while servicing this equipment.

### **⚠ IMPORTANT**

The Clean Air Act of 1990 bans the intentional venting of refrigerant (CFCs, HCFCs and HFCs) as of July 1, 1992. Approved methods of recovery, recycling or reclaiming must be followed. Fines and/or incarceration may be levied for noncompliance.

### **General**

These instructions are intended as a general guide and do not supersede local codes in any way. Consult authorities who have jurisdiction before installation.

### **Table of Contents**

General .....	1
CR33 Series Coils .....	1
Shipping and Packing List .....	2
Specifications .....	2
Dimensions .....	2
Model Number Identification .....	4
Dry Air Charge Release .....	5
Plenum Installation .....	5
Coil Installation .....	6
Condensate Drain Installation .....	6
Blower Speed Adjustment .....	8

### **CR33 Series Coils**

CR33 downflow evaporator coils are designed for use with condensing units or heat pumps. Each coil is equipped with a compression fitting that provides convenient field installation of a refrigerant metering device. Either a refrigerant metering orifice (provided with some Lennox condensing units) or a thermal expansion valve (ordered separately) may be used in condensing unit applications. A check / expansion valve (ordered separately) is the only metering device approved for use in heat pump applications.

Refer to the Lennox Engineering Handbook for proper use of these coils with Lennox air conditioners units, heat pumps and line sets.

### **Shipping and Packing List**

Package 1 of 1 contains the following:

- 1 - CR33 evaporator coil
- 1 - Bag assembly containing:
  - 3 - Straight coil locators (24B, 30/36B, 30/36C, 48C, 60D)
  - 3 - Coil locators — 2 angular and 1 straight coil locators (18A, 24A, 30/36A, 48B, 50/60C)
  - 6 - #8 screws for fastening coil locators
  - 1 - Liquid line stub (3/8" copper swaged)
  - 1 - O-ring
  - 1 - Warranty card
  - 1 - Installation instructions

Check equipment for shipping damage. If you find any damage, immediately contact the last carrier.



Specifications		1.5 to 3 Ton				
General Data	Model No.	CR33-18A-F	CR33-24A-F	CR33-24B-F	CR33-30/36A-F	CR33-30/36B-F
	Nominal size - tons	1.5	2	2	2.5/3	2.5/3
Line connections in. (mm)	Suction / vapor o.d. - sweat	7/8 (22.2)	7/8 (22.2)	7/8 (22.2)	7/8 (22.2)	7/8 (22.2)
	Liquid o.d. - sweat	3/8 (9.5)	3/8 (9.5)	3/8 (9.5)	3/8 (9.5)	3/8 (9.5)
	Condensate drain (fpt)	(2) 3/4 (19)	(2) 3/4 (19)	(2) 3/4 (19)	(2) 3/4 (19)	(2) 3/4 (19)
Indoor Coil	Net face area sq. ft. (m <sup>2</sup> )	3.5 (0.33)	3.21 (0.30)	3.21 (0.30)	4.08 (0.38)	4.08 (0.38)
	Tube diameter - in. (mm)	3/8 (9.5)	3/8 (9.5)	3/8 (9.5)	3/8 (9.5)	3/8 (9.5)
	Number of rows	2	3	3	3	3
	Fins per inch (m)	18 (709)	12 (472)	12 (472)	12 (472)	12 (472)
Shipping weight	lbs. (kg) 1 package	44 (20)	44 (20)	49 (22)	58 (26)	57 (26)

Specifications		3 to 5 Ton				
General Data	Model No.	CR33-30/36C-F	CR33-48B-F	CR33-48C-F	CR33-50/60C-F	CR33-60D-F
	Nominal size - tons	2.5/3	4	4	4/5	5
Line connections in. (mm)	Suction / vapor o.d. - sweat	7/8 (22.2)	7/8 (22.2)	7/8 (22.2)	7/8 (22.2)	7/8 (22.2)
	Liquid o.d. - sweat	3/8 (9.5)	3/8 (9.5)	3/8 (9.5)	3/8 (9.5)	3/8 (9.5)
	Condensate drain (fpt)	(2) 3/4 (19)	(2) 3/4 (19)	(2) 3/4 (19)	(2) 3/4 (19)	(2) 3/4 (19)
Indoor Coil	Net face area sq. ft. (m <sup>2</sup> )	4.08 (0.38)	5.25 (0.49)	5.25 (0.49)	6.42 (0.60)	6.42 (0.60)
	Tube diameter - in. (mm)	3/8 (9.5)	3/8 (9.5)	3/8 (9.5)	3/8 (9.5)	3/8 (9.5)
	Number of rows	3	3	3	3	3
	Fins per inch (m)	12 (472)	12 (472)	12 (472)	12 (472)	12 (472)
Shipping weight	lbs. (kg) 1 package	60 (27)	72 (33)	71 (32)	85 (39)	84 (38)

### Dimensions - Inches (MM)

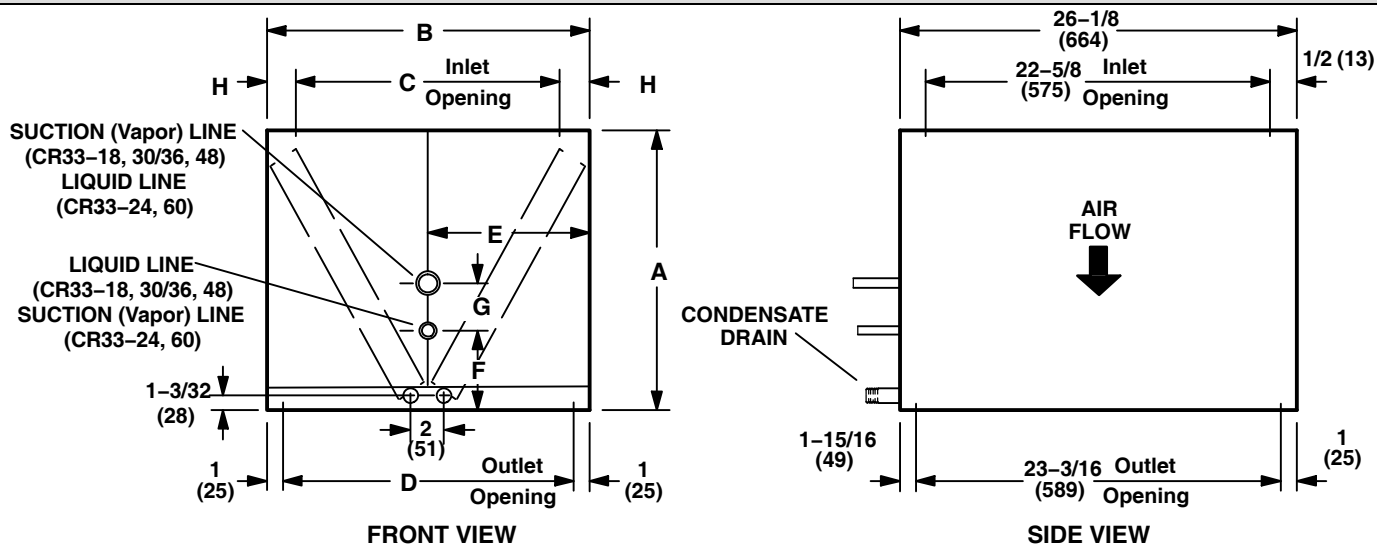

**NOTE - Liquid and Suction Line locations are reversed on CR33-24 and CR33-060 models.**

Model Number	A		B		C		D		E		F		G		H	
	in.	mm	in.	mm	in.	mm	in.	mm	in.	mm	in.	mm	in.	mm	in.	mm
CR33-18A-F	14-1/8	359	17-1/2	445	13-1/2	343	15-1/2	394	8-3/4	222	6-1/4	159	3	76	2	51
CR33-24A-F	14-1/8	359	17-1/2	445	13-1/2	343	15-1/2	394	8-3/4	222	5	127	5	127	2	51
CR33-24B-F	14-1/8	359	17-1/2	445	16-1/2	419	15-1/2	394	8-3/4	222	5	127	5	127	1/2	13
CR33-30/36A-F	16-1/8	410	17-1/2	445	13-1/2	343	15-1/2	394	8-3/4	222	6-1/8	156	3	76	2	51
CR33-30/36B-F	16-1/8	410	17-1/2	445	16-1/2	419	15-1/2	394	8-3/4	222	6-1/8	156	3	76	1/2	13
CR33-30/36C-F	16-1/8	410	21	533	20	508	19	483	10-1/2	267	6-1/8	156	3	76	1/2	13
CR33-48B-F	20	508	21	533	16-1/2	419	19	483	10-1/2	267	8-1/8	206	4	102	2-1/4	57
CR33-48C-F	20	508	21	533	20	508	19	483	10-1/2	267	8-1/8	206	4	102	1/2	13
CR33-50/60C-F	23-5/8	600	24-1/2	622	20	508	22-1/2	572	12-1/4	311	3-1/2	89	17-3/16	437	2-1/4	57
CR33-60D-F	23-5/8	600	24-1/2	622	23-1/2	597	22-1/2	572	12-1/4	311	3-1/2	89	17-3/16	437	1/2	13

**Dimensions - Inches (MM)**

**PHYSICAL MATCHES**

**DOWNFLOW GAS FURNACES - CR33 COILS**

(Note - Coil opening will physically match the furnace supply air opening with the same letter designation in the model number.)

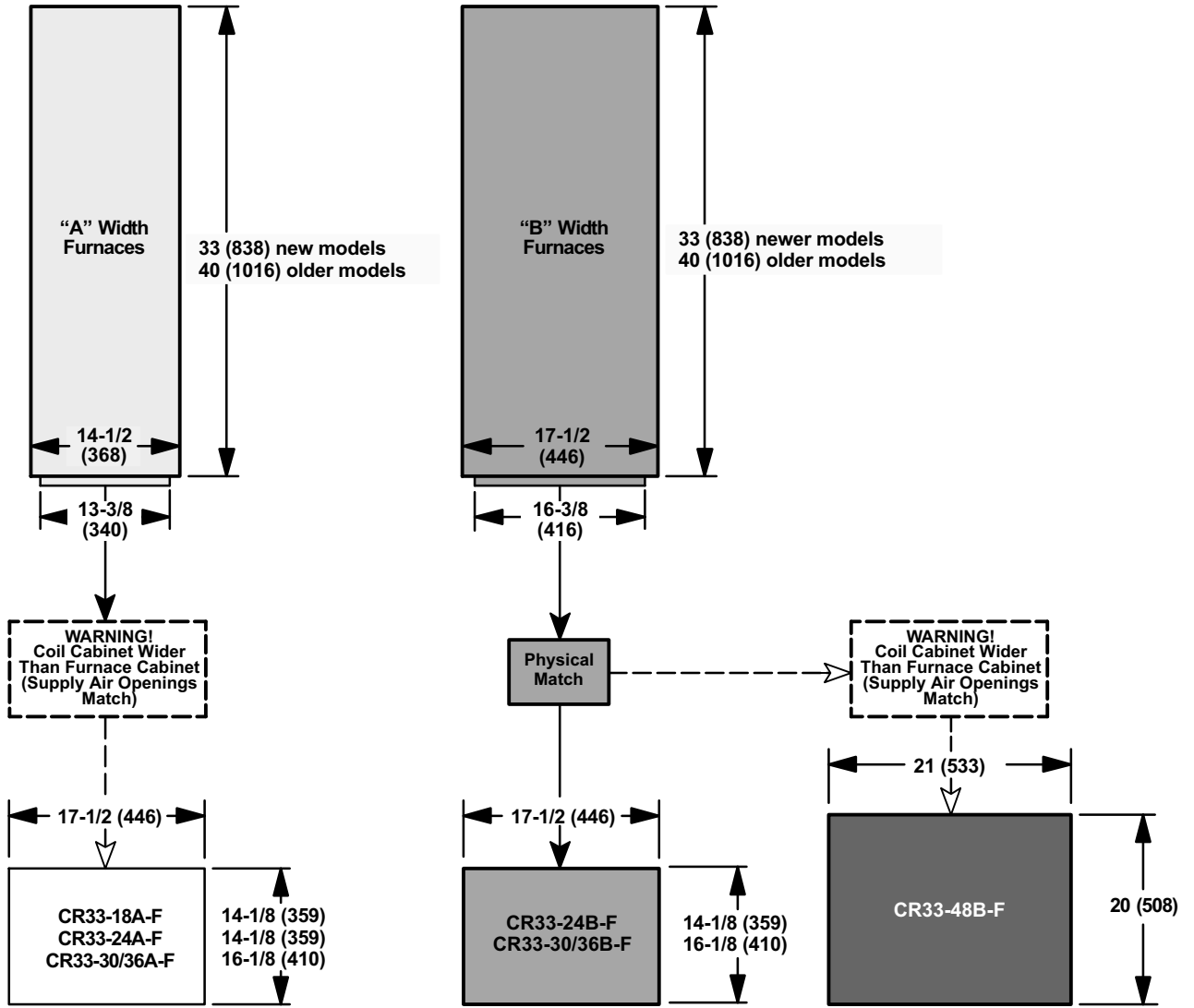

(Continued on next page)

## Dimensions - Inches (MM)

### PHYSICAL MATCHES

#### DOWNFLOW GAS FURNACES - CR33 COILS

(Note - Coil opening will physically match the furnace supply air opening with the same letter designation in the model number.)

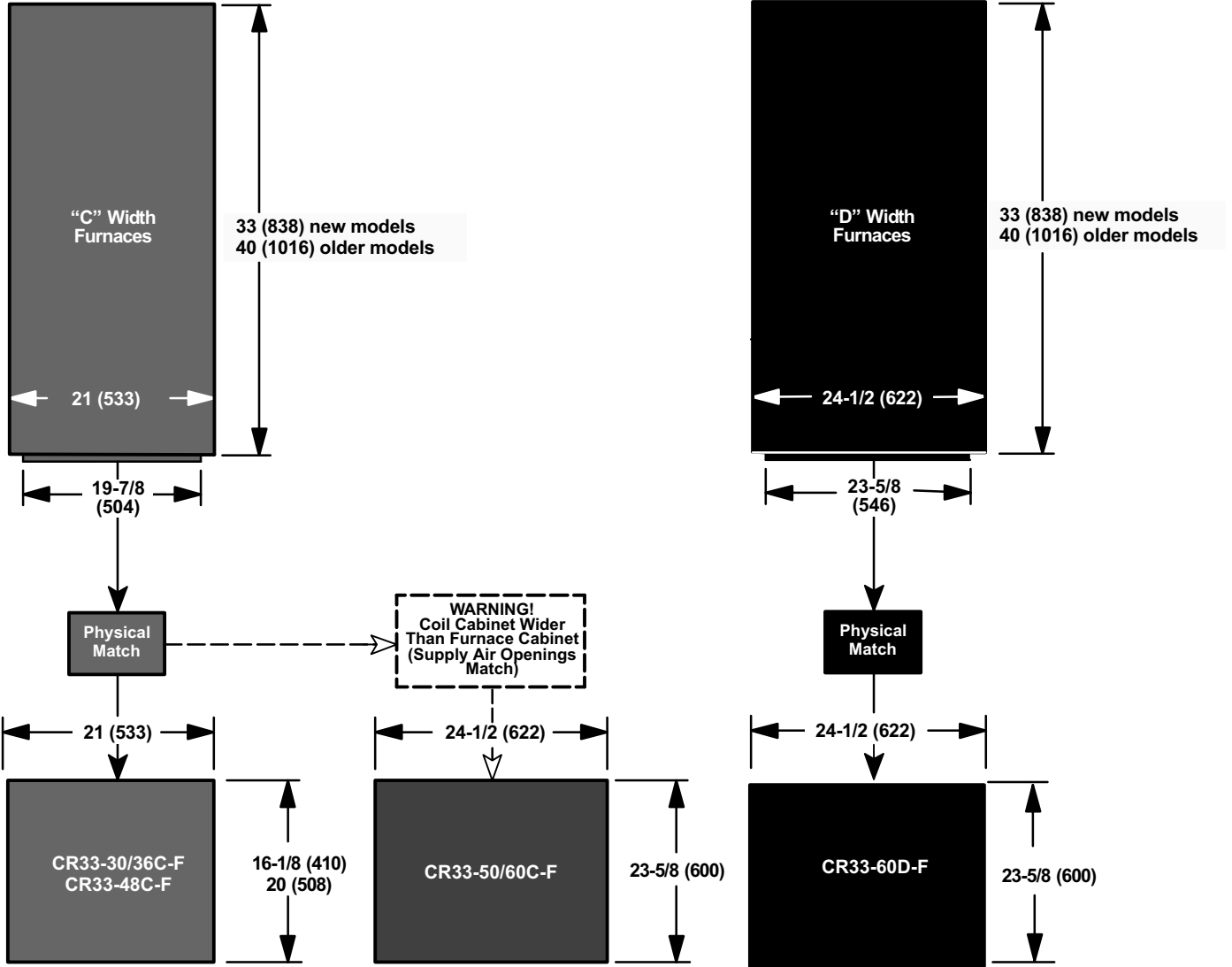

### Model Number Identification

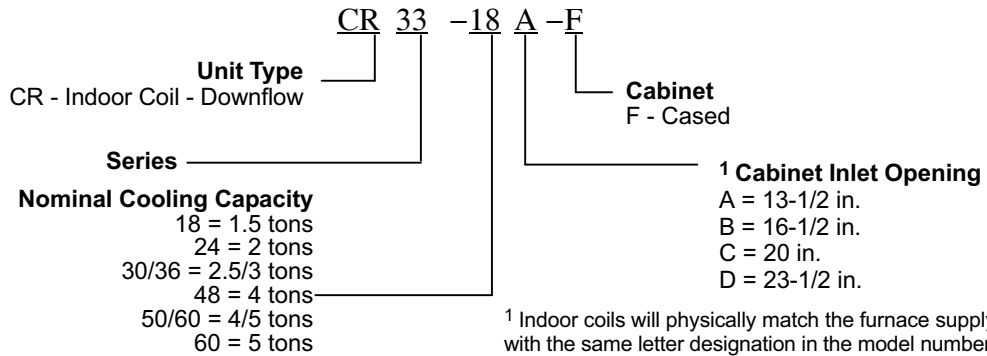

## Dry Air Charge Release

The CR33 coils are shipped with a 10 psi dry air holding charge. Puncture the suction line rubber plug to release the charge. Remove the rubber plug.

*NOTE - If there is no pressure when the rubber plug is punctured, check the coil for leaks before installing the coil.*

Loosen and remove the liquid line compression fitting. Remove and discard the plug which is in the distributor body.

## Plenum Installation

See table 1 for the dimensions of the floor opening required to accommodate the supply air opening and the plenum. If the unit is installed against a wall, the rear edge of the opening must be at least 1" (25 mm) from the wall. Cut an appropriately sized opening.

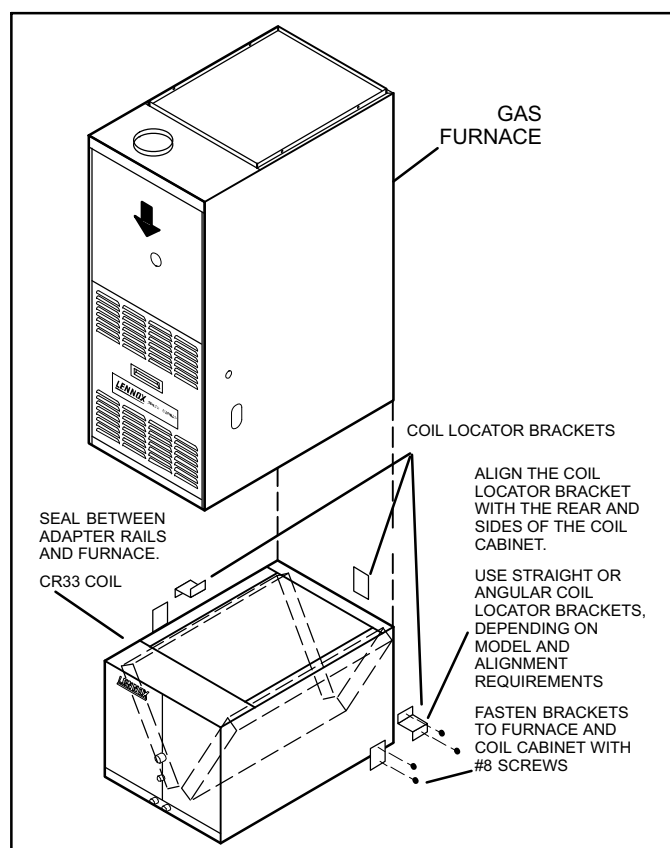

**Figure 1. Gas Furnace and Coil**

- 1. Lower plenum through floor opening**—Align the the base of the unit with the matching plenum, then lower the unit over the plenum. The coil cabinet must be either level or sloped slightly toward the drain outlet and secured and sealed to the plenum. **If the furnace and coil cabinet are the same size, skip to step 3.**

**Table 1. Floor Opening Dimensions**

CR33 Unit	Side to Side	Front to Rear
-18A, -24A, -24B, -30/36A, -30/36B	14-1/4" (394mm)	23" (584mm)
-30/36C, -48B, -48C	19 (483mm)	
-50/60C, -60D	22-1/2" (571mm)	

## CAUTION

Do not install screws through the drain pan.

- 2. Coil Cabinet Width**—Install the provided coil locator brackets on the coil. Align the coil locator brackets with the rear and sides of the coil cabinet. Figure 1 illustrates how the furnace, coil and coil locator brackets fit together.

## CAUTION

If the furnace flange height is greater than 5/8" (16 mm), damage may occur to coil. Notch flange so that it does not contact coil slabs.

## WARNING

There must be an airtight seal between the top of the furnace and the return air plenum. Use fiberglass sealing strips, caulking, or equivalent sealing method between the plenum and the furnace cabinet to ensure a tight seal. Return air must not be drawn from a room where this furnace or any gas-fueled appliance (i.e., water heater), or carbon monoxide-producing device (i.e., wood fireplace) is installed.

- 3. Sealing**—Seal between the furnace cabinet and the coil cabinet to prevent air leaks.
- 4.** As you lower the furnace onto the coil, align the flanges of the furnace and the the coil cabinet.

## Refrigerant Line Connections

The refrigerant line sets should be sized according to the recommendations given in the condensing unit or heat pump installation instructions (see table 2 for sweat connection sizes). A field-provided adapter may be required to match line set connections.

**Table 2. Refrigerant Line Connection Sizes - in (mm)**

Model	Suction (Vapor) Line Sweat Size	Liquid Line Sweat Size
All Sizes	7/8 (22.0)	3/8 (9.5)
NOTE — Some applications may require a field-provided 7/8" to 1-1/8" adapter.		

*NOTE — When installing refrigerant lines longer than 50 feet, see the Lennox Refrigerant Piping Design and Fabrication Guidelines, CORP. 9351-L9, or contact Lennox Technical Support Product Applications for assistance.*

## Brazing Coil Connections

1. Place a field-provided heat shield, such as a wet rag, against the piping plate and around the piping stubs, and sweat in the suction line. The heat shield must be in place to guard against heat damage to the paint.
2. Slide the liquid line compression nut onto the provided liquid line stub. Insert the field-supplied liquid line into the liquid line stub for brazing.
3. Braze liquid line and coil connections. Use a silver alloy brazing rod (5 or 6 percent silver alloy for copper-to-copper connections or 45 percent silver alloy for copper-to-brass or copper-to-steel connections).
4. Remove the heat shield after brazing and allow the connections to cool.
5. Select the appropriate refrigerant metering device - refrigerant flow control orifice, expansion valve or check/expansion valve.

## Metering Device Installation

Install either a refrigerant flow control orifice or (check /) thermal expansion valve. Refer to either the outdoor unit installation instruction, coil engineering handbook, Lennox product catalog or price book for approved metering device.

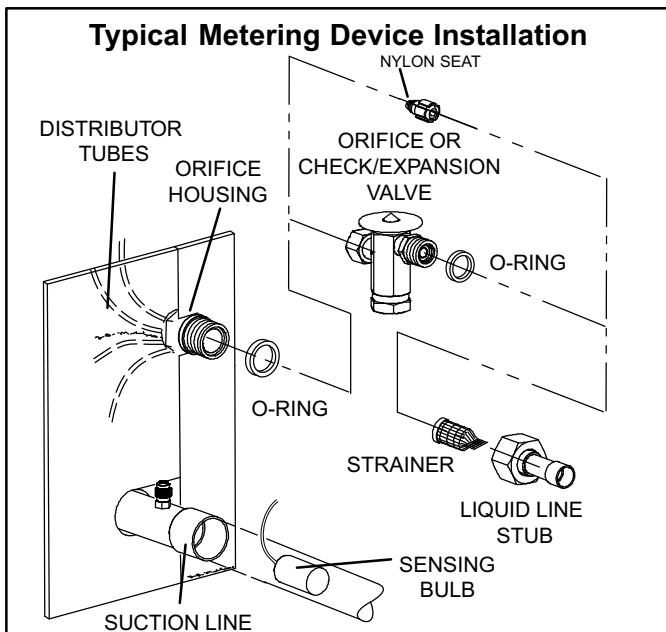

Figure 2. Typical Metering Device Installation

### Refrigerant Flow Control Orifice

To install the refrigerant flow control orifice:

1. Ensure that the orifice is installed with the nylon seat pointing toward the distributor (see figure 2).
2. Apply a small amount of refrigerant oil on the O-ring and insert the O-ring securely into the orifice housing.

3. Screw the liquid line stub to the orifice housing. Tighten the compression fitting to 20 ft.-lbs.
4. The suction line service port has no core. Make sure that the service port cap is tightened securely.
5. Insulate the refrigerant lines at the connections to prevent sweating.

*NOTE - Slide Armaflex® insulation up to cabinet to cover all of the suction line and seal cabinet opening.*

## ⚠ IMPORTANT

All piping, metering devices and connections must be insulated to prevent moisture damage caused by sweating.

### Check / Thermal Expansion Valve

To install the check/thermal expansion valve:

1. Remove factory-installed metering orifice from orifice housing (see figure 2).
2. Apply a small amount of refrigerant oil on the O-ring (shipped with the valve assembly) and place it securely in the orifice housing.
3. Insert the expansion valve into the orifice housing and tighten the expansion valve compression fitting.
4. Screw the liquid line compression nut (with the liquid line) on the threaded end of the expansion valve. Tighten the fitting to 20 ft.-lbs.
5. Install the expansion valve equalizer line on the suction line service port.

*NOTE - Make sure that the equalizer line fitting is tightened securely.*

6. Use the clamp provided with the valve assembly to secure the sensing bulb to the suction line.

## ⚠ IMPORTANT

The sensing bulb must be positioned as shown in figure 2 to ensure proper valve operation.

All piping, metering devices, and connections must be insulated to prevent moisture damage caused by sweating. If the equipment is not properly insulated, moisture could damage other equipment.

### Condensate Drain Installation

## ⚠ IMPORTANT

After removal of drain pan plug(s), check drain hole(s) to verify that drain opening is fully open and free of any debris. Also check to make sure that no debris has fallen into the drain pan during installation that may plug up the drain opening.

## MAIN DRAIN

Connect the main drain and route downward to drain line or sump. Do not connect drain to a closed waste system. See figure 3 for typical drain trap configuration.

## OVERFLOW DRAIN

It is recommended that the overflow drain is connected to a overflow drain line for all units. If overflow drain is not connected, it must be plugged with provided cap.

The overflow drain **MUST** be connected and routed to a overflow drain line

## BEST PRACTICES

The following best practices are recommended to ensure better condensate removal:

- Main and overflow drain lines should **NOT** be smaller than both drain connections at drain pan.
- Overflow drain line should run to an area where homeowner will notice drainage.
- It is recommended that the overflow drain line be vented and a trap installed. Refer to local codes.

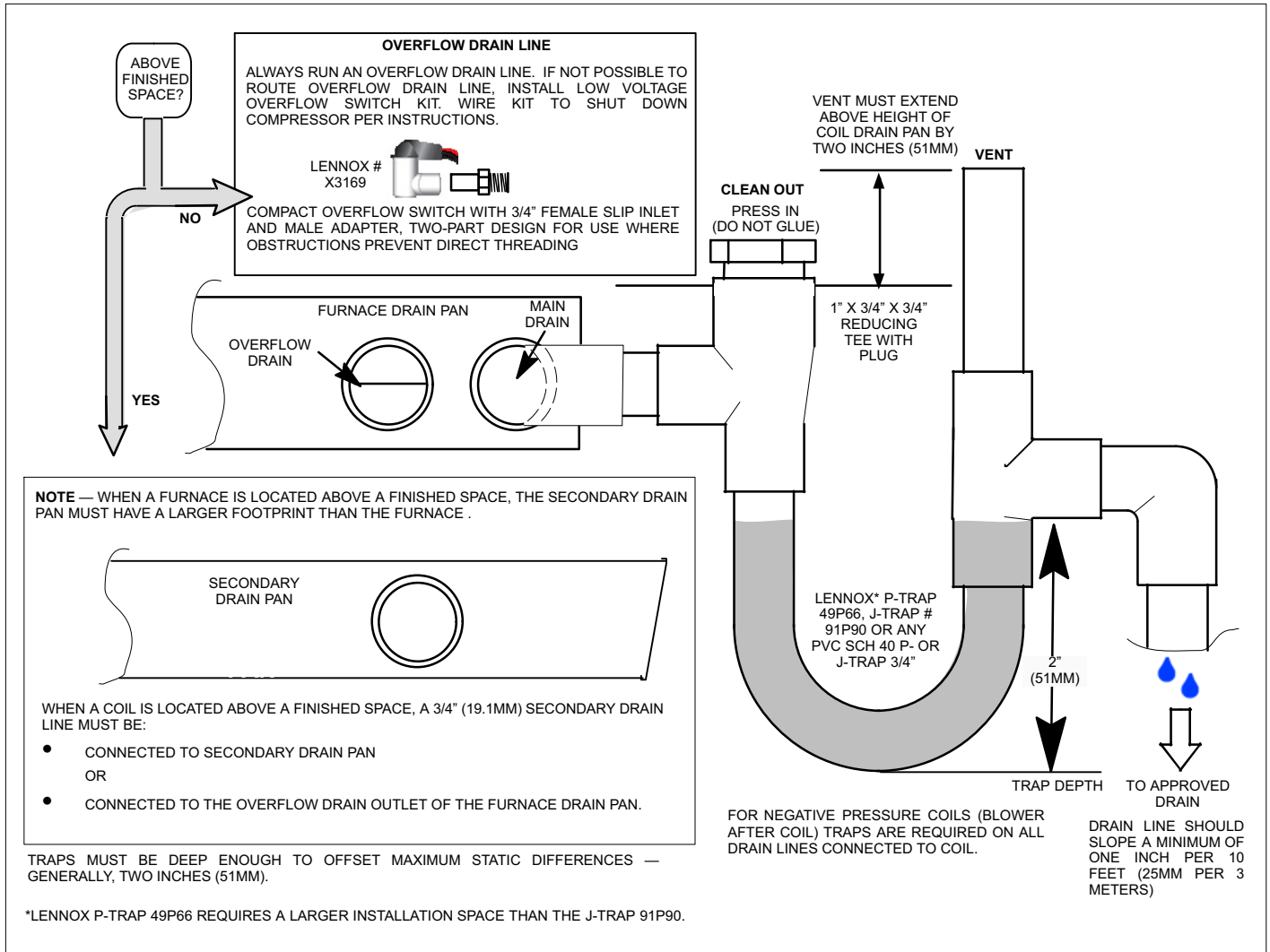

Figure 3. Typical Main and Overflow Drain Installations

## Blower Speed Adjustment

Proper air volume **MUST** be provided over the evaporator coil. To ensure that the static pressure is within the proper range, take a draft gauge reading as follows:

### **⚠ CAUTION**

Access panel must be removed before drilling air test holes.

1. Remove access panel.
2. Drill two 5/16" (8 mm) air test holes in the right front access panel; hole locations are shown in figure 4. Replace the panel.
3. Connect draft gauge. Zero end of draft gauge scale connects to air entering hole of the coil. Insert gauge hoses into test holes about 5/16" (8 mm). Seal around holes with permagum.
4. Turn off power to the outdoor unit, then set the thermostat for high stage cooling.

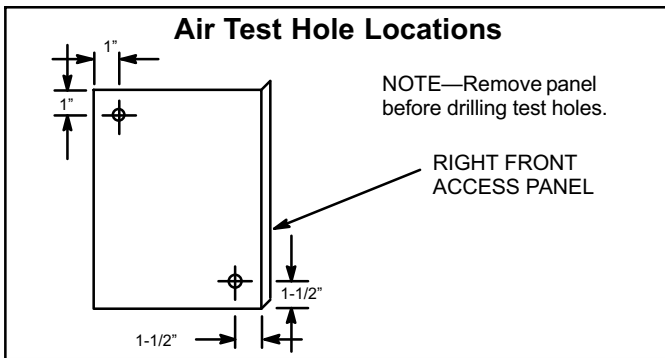

**Figure 4. Air Test Hole Locations**

5. Table 3 lists the range of air volumes and equivalent draft gauge readings for this unit. Observe draft gauge reading. If reading is above required air volume, decrease blower speed. Refer to furnace wiring diagram for changing direct drive blower speed. Do not exceed maximum air volume as indicated in diagram blower speed table.
6. After required draft gauge readings are obtained, remove draft lines and seal air test holes.
7. Set the room thermostat to desired temperature.

## Maintenance

A trained technician or service agency must perform maintenance and service on equipment. At the beginning of each heating or cooling season, indoor coils should be cleaned.

Do not use hydrofluoric acid, alkaline, or similar chemicals on coils. These chemicals are not necessary to dissolve salt, and may damage the fin coating. Acid washes are used to dissolve oils and greases, which generally are not present on most installations.

Do not use alkaline washes to dissolve oxides such as zinc oxide, aluminum oxide, and iron oxide (rust). These three oxides are more corrosion-resistant than base metals. Dissolving or removing them will cause an increase in corrosion.

### **⚠ CAUTION**

A damaged coil fin can affect equipment operation and performance. Do not use flame, high-pressure water, steam, or volatile cleaners on fins or tubing surfaces. If cleaning requires the use of acidic or alkaline cleaners, follow the manufacturer's instructions. Thoroughly flush cleaner from all equipment components. (Be careful to prevent damage or corrosion of the components connected to the system or areas surrounding the equipment being cleaned.)

### Cleaning the coil:

1. Remove the coil from the cabinet and take the coil to an appropriate place to clean it.
2. Vacuum or brush the coil to remove matted and surface debris from the fin. Use vacuum attachments and /or brushes that are non-destructive to fins.
3. If oil deposits are present, spray the coil with ordinary household liquid detergent. Allow detergent to soften deposits. Wait 10 minutes.

*NOTE - For units in coastal regions, fresh water will dissolve salt deposits. (Wash coils with fresh water at least every six months.)*

4. Spray the coil at a vertical angle of 30 to 45 degrees with a constant stream of water at moderate pressure. A pressure washer with a fan nozzle will work best. Do not spray the coil from a horizontal direction.
5. Direct the spray so that any debris is washed out of the coil and base pan. For most residential units, hot water is not necessary.

*NOTE - Attempting to back flush from the inside of the coil will require removing parts from the unit, and it may be very difficult to flush the whole coil surface. Attempting to blow water through a coil will slow the water stream and reduce the flushing action of the outer fin surface.*

6. Replace the coil into the cabinet.



**Table 3. CR33 Coil Air Volume and Static Pressure Resistance**

Model No.	Dry Coil				Wet Coil				Model No.	Dry Coil				Wet Coil			
	Resistance		Air Volume		Resistance		Air Volume			Resistance		Air Volume		Resistance		Air Volume	
	in.w.g.	Pa	cfm	L/s	in.w.g.	Pa	cfm	L/s		in.w.g.	Pa	cfm	L/s	in.w.g.	Pa	cfm	L/s
18A-F	.05	12	370	175	.05	12	255	121	24A-F	.05	12	315	150	.05	12	335	157
	.08	19	510	240	.07	17	305	144		.09	22	465	220	.10	25	490	231
	.10	25	645	305	.09	22	355	167		.14	35	595	280	.15	37	600	284
	.15	37	815	385	.12	30	395	186		.20	50	725	345	.20	50	705	332
	.20	50	980	465	.15	37	435	205		.25	62	825	390	.25	62	790	373
	.25	62	1115	525	.18	44	520	245		.30	75	910	430	.30	75	870	411
	.30	75	1250	590	.20	50	600	284		.35	87	1000	470	.35	87	940	444
	.35	87	1395	660	.25	62	690	325		.40	100	1080	510	.40	100	1020	481
	.40	100	1535	725	.30	75	775	365		.50	125	1225	580	.45	112	1090	514
	.45	112	1645	775	.35	86	845	399		.60	150	1370	645	.51	127	1160	547
	.50	125	1760	830	.39	97	920	433									
.55	137	1870	880	.50	125	1505	711										
24B-F	.06	15	400	190	.07	17	400	189	30/36A-F	.10	25	600	283	.10	25	600	283
	.09	22	500	235	.10	25	500	236		.13	32	700	330	.14	35	700	330
	.13	32	600	285	.15	37	600	283		.16	40	800	378	.18	45	800	378
	.17	42	700	330	.20	50	700	330		.20	50	900	425	.23	57	900	425
	.23	57	800	380	.26	65	800	378		.24	60	1000	472	.27	67	1000	472
	.27	67	900	425	.32	80	900	425		.28	70	1100	519	.32	80	1100	519
	.33	82	1000	470	.39	97	1000	472		.33	82	1200	566	.38	95	1200	566
	.39	97	1100	520	.46	115	1100	519		.38	94	1300	614	.43	107	1300	614
	.47	117	1200	565	.54	135	1200	566		.43	107	1400	661	.49	122	1400	661
30/36B-F	.05	12	525	245	.05	12	410	194	30/36C-F	.06	15	600	285	.07	17	600	283
	.08	19	660	310	.08	19	495	233		.08	20	700	330	.10	25	700	330
	.10	25	795	375	.10	25	580	273		.10	25	800	380	.13	32	800	378
	.15	37	980	465	.15	37	785	371		.13	32	900	425	.17	42	900	425
	.20	50	1165	550	.20	50	995	469		.16	40	1000	470	.21	52	1000	472
	.25	62	1320	625	.25	62	1155	546		.19	47	1100	520	.25	62	1100	519
	.30	75	1475	695	.30	75	1320	624		.22	55	1200	565	.29	72	1200	566
	.35	87	1605	760	.35	87	1465	692		.26	65	1300	615	.34	85	1300	614
	.40	100	1735	820	.40	100	1610	761		.29	72	1400	665	.38	95	1400	661
	.43	107	1805	855	.45	112	1730	816									
.46	115	1875	885	.50	125	1850	872										
48B-F	.14	35	1200	566	.17	42	1200	566	48C-F	.05	12	595	280	.05	12	575	271
	.16	40	1300	614	.20	50	1300	614		.10	25	860	405	.10	25	820	386
	.19	47	1400	661	.23	57	1400	661		.15	37	1060	500	.15	37	995	469
	.22	55	1500	708	.26	65	1500	708		.20	50	1235	580	.20	50	1170	551
	.25	62	1600	755	.29	72	1600	755		.25	62	1395	655	.25	62	1320	623
	.28	70	1700	802	.32	80	1700	802		.30	75	1545	730	.30	75	1445	682
	.30	75	1800	850	.36	90	1800	850		.35	87	1675	790	.35	87	1575	744
	.34	85	1900	897	.42	105	1900	897		.40	99	1805	850	.40	100	1710	807
	.37	92	2000	944	.45	112	2000	944		.45	112	1925	910	.45	112	1825	861
								.50	124	2030	960	.50	125	1915	904		
50/60C-F	.17	42	1395	660	.19	47	1400	661	60D-F	.17	42	1395	660	.19	47	1400	661
	.18	45	1450	685	.20	50	1450	684		.18	45	1450	685	.20	50	1450	684
	.19	47	1500	710	.22	55	1500	707		.19	47	1500	710	.22	55	1500	707
	.20	50	1545	730	.23	57	1555	733		.20	50	1545	730	.23	57	1555	733
	.21	52	1605	755	.24	60	1600	755		.21	52	1605	755	.24	60	1600	755
	.22	55	1645	775	.25	62	1645	777		.22	55	1645	775	.25	62	1645	777
	.24	60	1700	805	.27	67	1710	807		.24	60	1700	805	.27	67	1710	807
	.25	62	1750	825	.28	70	1745	824		.25	62	1750	825	.28	70	1745	824
	.27	67	1805	850	.31	77	1800	850		.27	67	1805	850	.31	77	1800	850
	.28	70	1845	870	.32	80	1850	874		.28	70	1845	870	.32	80	1850	874
	.29	72	1905	900	.33	82	1890	892		.29	72	1905	900	.33	82	1890	892
	.30	75	1950	920	.34	85	1950	920		.30	75	1950	920	.34	85	1950	920
	.32	80	2000	945	.36	90	2000	944		.32	80	2000	945	.36	90	2000	944
	.33	82	2055	970	.38	95	2050	968		.33	82	2055	970	.38	95	2050	968
	.35	87	2105	995	.40	100	2105	993		.35	87	2105	995	.40	100	2105	993
	.38	94	2150	1015	.43	107	2150	1015		.38	94	2150	1015	.43	107	2150	1015
	.39	97	2200	1040	.45	112	2190	1034		.39	97	2200	1040	.45	112	2190	1034

